

THE

MECHANIC'S FRIEND:

A COLLECTION OF

RECEIPTS AND PRACTICAL SUGGESTIONS.

300 ILLUSTRATIONS.



M. J. P.

M



LIBRA

MENT.

T:
Q971

ACCESSION No. 6428

FINDING No. 1355:2





THE MECHANIC'S FRIEND.

PRINTED BY BALLANTYNE AND COMPANY
EDINBURGH AND LONDON

THE
MECHANIC'S FRIEND;

A COLLECTION OF
RECEIPTS AND PRACTICAL SUGGESTIONS

RELATING TO

AQUARIA,	GLUES,	PYROTECHNY,
BRONZING,	HOROCLOGY,	RAILWAYS,
CEMENTS,	LACQUERS,	SOLDERS,
DRAWING,	LOCOMOTIVES,	STEAM-ENGINE,
DYES,	MAGNETISM,	TELEGRAPHY,
ELECTRICITY,	METAL-WORKING,	TAXIDERMY,
GILDING,	MODELLING,	VARNISHES,
GLASS-WORKING,	PHOTOGRAPHY,	WATERPROOFING,

AND

MISCELLANEOUS TOOLS, INSTRUMENTS, MACHINES, AND PROCESSES
CONNECTED WITH THE CHEMICAL AND MECHANICAL ARTS.

With Numerous Diagrams and Woodcuts.

Edward
EDITED BY

Wm. Axon
WILLIAM E. A. AXON, M.R.S.L., F.S.S.

MEMBER OF THE LITERARY AND PHILOSOPHICAL SOCIETY OF MANCHESTER, ETC. ETC.

NEW YORK:
D. VAN NOSTRAND.

1875.

T49
.A9



P R E F A C E.



THE present differs in some important particulars from the many "receipt-books" which have preceded it. It is the result, not so much of individual judgment as of the action of a number of "friends in council," whose varied practical experiences have inspired the instructions and hints it contains. The articles of which the volume consists have already appeared in the *English Mechanic*, a well-known periodical, in whose pages lovers of science, practical mechanics, chemists, photographers, &c. &c., have for years past been in the habit of affording mutual help to each other. Hence almost every item of information in the present volume is a statement of a difficulty experienced by one person, and responded to by another, who has already met and overcome it. This fact will stamp the book with a practical value in the eyes of those who know how much more important such individual experience is than any mere theory or tradition. The workman

who looks here for help will know that he is listening to those who have been in his own circumstances, and who by perseverance, it may be, in spite of repeated failures, have at last found out the method they now offer to him.

There is a large and rapidly-increasing class of amateurs who devote some of their leisure to working in the mechanical and other branches of practical science. These persons will, it is hoped, in this volume find many things to save them trouble and speed them on their way. Whether they want to skeletonize the leaf of a plant, or to construct a steam-propeller for a model boat; to make a sky-rocket or an electric clock; an artificial magnet or a photographic handkerchief, they will not look in vain. The tendency to the traditional in every trade renders it probable that, with persons of this class, many improved processes will originate. The amateur workman looks at things with a fresher eye than one who has come to regard the processes learned in youth as the finale of perfection. Discoveries sometimes arise from the extension of principles and methods that have proved successful in one department to other spheres of operation. Bearing this in mind, it is perhaps not to be regretted that so few men adopt as "hobby" the pursuits by which their living is obtained. The joiner whose evenings are given up

to clockmaking, the printer whose holiday-time is spent in photography, are not to be discouraged as perverse. They bring trained intelligence to bear upon fresh fields, and the stoutest resister of outside suggestions in his *trade* may be the most daring experimenter in relation to his *hobby*. Both classes will, it is hoped, find something to suit them in the following pages.

In preparing for the press the contributions of so many individuals, a considerable amount of revision and condensation has been necessary, and every possible care has been taken to exclude matter already easily accessible.

The topics have, as far as possible, been grouped together according to their mutual relationship; but as all such attempts at classification are in their very nature defective, this arrangement has been supplemented by a copious alphabetical index.

TABLE OF CONTENTS.

	PAGE
METRIC SYSTEM	I
MISCELLANEOUS TOOLS, INSTRUMENTS, AND PROCESSES	3
CEMENTS AND GLUES	79
VARNISHES AND LACQUERS	83
SOLDERS AND SOLDERING	90
METALS AND METAL-WORKING	92
STEAM ENGINE	102
RAILWAYS AND LOCOMOTIVES	130
FIRE-ARMS	148
HOROLOGY	150
GLASS	175
WOOD-WORKING	179
HOUSE AND GARDEN	184
DRAWING AND MODELLING	197
PHOTOGRAPHY	203
MUSICAL INSTRUMENTS	228
TAXIDERMY	234
PLANT PRESERVING	238

	PAGE
AQUARIA	240
MISCELLANEOUS CHEMICAL PROCESSES AND COMPOSITIONS	246
LIGHTING	262
DYES	265
WATERPROOFING	268
GILDING AND BRONZING	270
PYROTECHNY	289
ELECTRICITY, MAGNETISM, AND TELEGRAPHY	295
INDEX	333

THE MECHANIC'S FRIEND.



French Weights and Measures, and their English Equivalents.—The very general use of the metrical system in scientific investigations renders a brief statement of it indispensable. The following will be found sufficient for all ordinary purposes :—

I.—WEIGHTS.

	=	English Troy Weight.			
		lbs.	oz.	dwt.	grains.
Bar (cubic metre of water)	=	5673	6	3	8
Myriagramme	=	26	9	10	20
Kilogramme	=	2	8	3	2
Hectogramme	=		3	4	7·4
Decagramme	=			6	10·34
GRAMME	=				15·434
Decigramme	=				1·5434
Centigramme	=				0·15434

II.—LINEAR MEASURES.

	French Foot.	English Foot.
Quadrant of meridian	= 30784440	= 32809167
Degree centesimal	= 307844·4	= 328091·67
Myriametre	= 30784·44	= 32809·167
Kilometre	= 3078·444	= 3280·9167
Hectometre	= 307·8444	= 328·09167
Decametre	= 30·78444	= 32·809167
METRE	= 3·078444	= 3·2809167

	French Lines.	English Lines.
Decimetre . . . =	44'3296	= 47'2452
Centimetre . . . =	4'43296	= 4'72452
Millimetre . . . =	0'443296	= 0'472452

III.—SQUARE MEASURES.

	French Square Feet.	English Square Feet.
Myriare . . . =	9476817'46113	= 10764414'3923
Kilare . . . =	947681'746113	= 1076441'43923
Hectare . . . =	94768'1746113	= 107644'143923
Decare . . . =	9476'81746113	= 10764'4143923
ARE . . . =	947'681746113	= 1076'44143923
Deciare . . . =	94'7681746113	= 107'644143923
Centiare . . . =	9'47681746113	= 10'7644143923

	French Square Inches.	English Square Inches.
Square decimetre =	13'646617 =	15'500765

	French Square Lines.	English Square Lines.
Square centimetre =	19'651134 =	22'321088
Square millimetre =	0'19651134 =	0'22321088

IV.—SOLID MEASURES.

The *Stere*, being a cubic metre, it follows that the *Decastere* is equal to the *Myrialitre*.

Stere	=	Kilolitre.
Decistere	=	Hectolitre.

V.—MEASURES OF CAPACITY.

	French Cubic Feet.	English Cubic Feet.
Myrialitre . . . =	291'738519	= 353'1714695
Kilolitre (or cubic metre) =	29'1738519	= 35'31714695
Hectolitre . . . =	2'91738519	= 3'531714695

	French Cubic Inches.	English Cubic Inches.
Decalitre . . . =	504'124160	= 610'2802806
LITRE (cubic decimetre) =	50'412416	= 61'02802806
Decilitre . . . =	5'0412416	= 6'102802806

	French Cubic Lines.	English Cubic Lines.
Centilitre . . . =	871'126926	= 1054'5643249

Hand Drilling-Machine.—The following machine answers

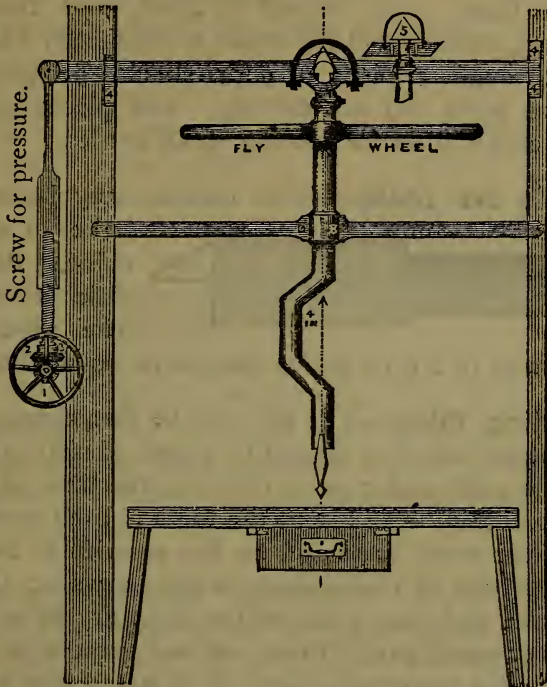

Fig. 1.

for all work, and is said to be nearly equal to steam power. The machine is made by E. & H. Widdall, of Beverley, Yorkshire. 1 is a small hand-wheel; 2, a pair of bevel-wheels; 3 is a stationary collar for pressure-screw; 4, the sliding-racks for lowering the drill; 5, centre of drill bolted to shaft. Fig. 2 is an end view of small wheel.

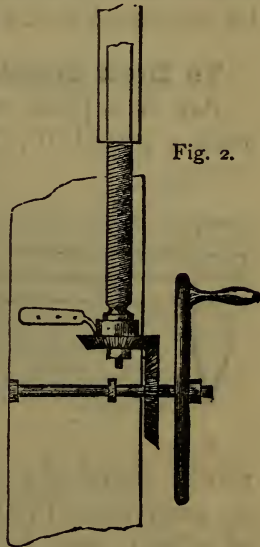

Fig. 2.

Cork-Boring.—There are three sorts of tools for boring cork: the French (Dang-er's), a sharp-edged steel cylinder, fixed in a handle, like a bradawl, with the cylinder partly cut away, to get the cut piece out. Mohr's way is to use a tin tube, with a milled rim at the handle end, and the pieces of cork push each other out at the top, as in a punch. The objection to this (the cheapest method) is the welt, which can hardly be

avoided in tin tubes. Griffin prefers a brass tube filed to an edge. All these tools should be oiled, and turned round while cutting, or they will not make a clean cut; when the tool is nearly through, a piece of cork should be placed at the back of the piece you are cutting. The pieces cut out are uninjured, and will do for corking small bottles.

Rose-Bit for Lathe.—This rose-bit may be used in the lathe or drilling-machine. As a counter-sink it works well. The nose is formed



by filing away to a little below the centre, as shown.

Renovating Files.—The file is to be first cleansed from all foreign matter, and then dipped in 1 part of nitric acid, 3 parts of sulphuric acid, and 7 parts of water, the time of immersion will be according to the extent the file has been worn, and the fineness of the teeth, varying from five seconds to five minutes; on taking it out of the mixture, wash in water, then dip in milk of lime, and then wash off the lime, dry by a gentle heat and rub over equal parts of olive oil and turpentine, and finally brush over with powdered coke. It is stated that a new file is improved by a few seconds' immersion, and also that rasps may be renovated in the same way.

To Draw Spirals.—A simple method of drawing spirals is :

AA is a piece of wood of any length, fitted near one end with a pencil B; CC is a string fixed at either end of the wood, and passing once round the roller D; E is placed at the centre, from which the spiral is to be described; F is an extra point to prevent turning round. As AA is

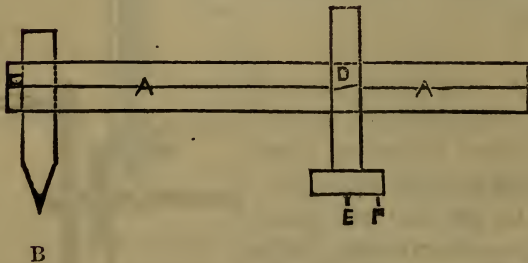

turned round the roller D, the pencil will be moved towards or away from it, and so a spiral will be described, the pitch of which may be altered by varying the diameter of the roller D.

Quickening Curves.—Spirals, or quickening curves, as they are called, are made as follows :—

Draw a straight line of any length ; divide this line into any number of equal parts, as shown in cut. Next divide one of these parts into halves, as at o ; now divide with the compasses (placing one foot upon o), strike the semicircle 1 2. Now place the compasses upon 1, extending them to 2, and strike the semicircle 2 3, but on the opposite side of the line from the other semicircle. Now return and place the foot of the compasses on o, extending them to 3, and upon the opposite side, and again strike the semicircle 3 4. Now return again to 1 and so on, alternately placing the compasses on o and 1, striking the curve on alternate sides of the line.

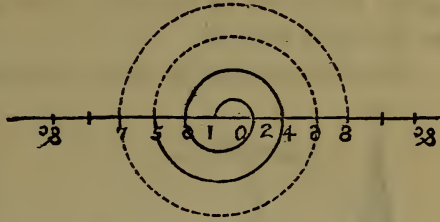

Measuring Heights of Towers, &c.—Various modes are in operation, but the following will be found simple and practical:

Choose that side of the tower around which the ground is most level. Should an entirely level plain not be obtainable, allowance must be made for the inequalities of the surface.

At some distance from the tower place level on the ground a small pocket mirror, C, and recede backwards from it until the top of the tower E is seen reflected in the centre of the mirror. Then, as experimenter's height BA is to his distance from mirror C, so is the distance CD to height of tower.



If, instead of a mirror, a trough of mercury, or even a pool of water, be employed for the reflection, the height of the

tower may be correctly ascertained, provided the base of it and the medium of reflection be on the same level. Should it not be possible to get a level base, the difficulty is got over when the relative heights of the tower base and the water or mercury are known, such difference having only to be added or subtracted when the water or mercury is below or above the tower's base, as the case may be.

Another method is this: Measure out the base line AB, 200 feet long, then erect a sliding staff, similar to the sketch at C, one-twentieth of the length of the base line from B, which will be ten feet. Then site his staff line BD in a direct line with E, by raising or lowering the top part of the staff, as the case may be. Hav-

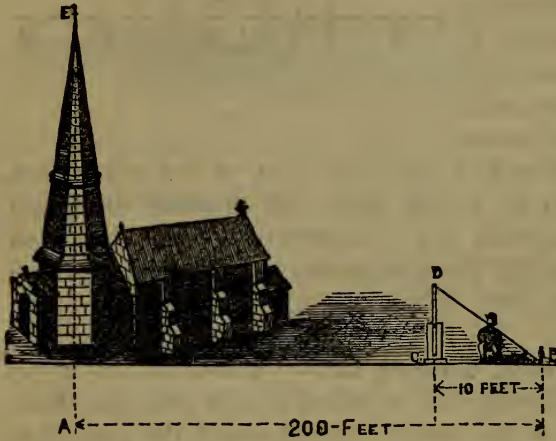

ing made the other end of the line fast at B once set, multiply the length of BD by 20—that is, the number of times the base line is divided into, which will give the exact length of the hypotenuse. Then the square root of the difference of the squares of the hypotenuse and the base is the height of the perpendicular. The sketch F of the sliding staff will explain itself.

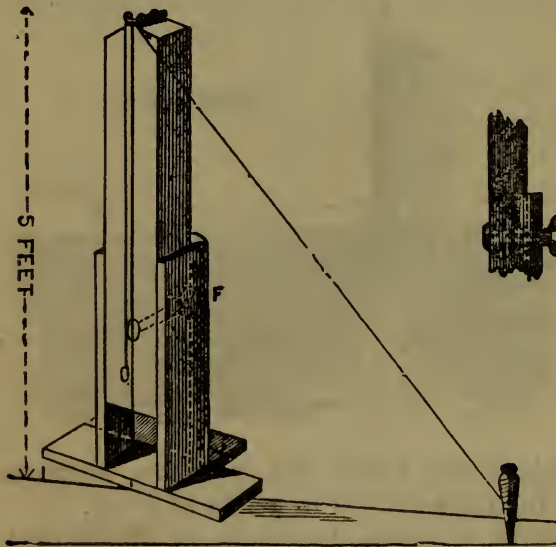

Distances: How to Ascertain.—The following plan, or

For horizontal distances, say a tree C, on the opposite side C of the river on which you are standing, fix a square or cross staff at A, and put a staff in the direction of the square at B; then, with the instrument in your hand, move backwards, looking at A \square in a direct line until you see the reflected image of C corresponding with A \square . Then measure the distance AB, and this is equal to CA.

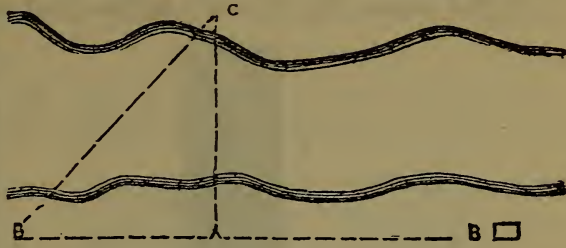

This instrument is, of course, held horizontally for the latter, and edgewise, or vertically, for perpendiculars.

Sharpening Edge Tools.—The simplest mode of sharpening an edge tool is to place the cutting part in water containing 1-20th of its weight of sulphuric or muriatic acid; after allowing it to remain there for half an hour, wipe it gently with a piece of soft rag, and in a few hours set in on an ordinary strop. This method, not generally known, is by no means new: the effect of the acid is to supply the place of the oilstone, but uniformly corroding the entire surface, so that nothing but a good polish is afterwards needed.

To Harden Axles.—To harden pattern axles with the prussiate of potash of commerce, make the work red hot, then put on plenty of potash, and plunge in water; or you may get some burnt leather or bone-dust. You can put a lot of axles into a wrought-iron box; put the bone-dust or leather-cinders in, ram down well, put some clay over the top, build a brick fire round the box for about three hours, then pull out, and rinse in cold water; this is the case-hardening process: you will find potash the quickest way.

To Temper Drills and Taps.—Heat them first to a blood-red, and then quench (this gives them extreme hardness, as well as brittleness), then, when dry, pour oil on them, and hold them in the fire, fixed in a piece of iron, till the oil blazes off, withdrawing very frequently to watch the process. This leaves a hardness that the file will just touch.

Protracting T-Square.—The following sketch of a protracting T-square will be found useful to many :—

A and B are the ordinary blades, and fixed stock. C is a



stock moving as usual on the clamp screw-pin D. Into the inner face of this stock there is a semicircle of planetree ($3\frac{1}{2}$ inches radius), indented, which is divided into degrees, and figured from 0 at EE' to 90°. There are spaces cut through the fixed stock at FF'; these are sloped to the centre, and laid with planetree, on which lines are drawn for reading off the degrees on the semicircle. G G are spaces in the semicircle, cut out for the fingers. It is useful for laying down or reading off angular lines, drawing polygons with any number of sides, shading at various angles in one or two directions.

To Temper Steel on one Edge.—Red-hot lead is an excellent thing in which to heat any long plate of steel that requires hardening only on one edge, for it need not be heated

in any other part but that which is required hard, and it will then keep straight in hardening; at least it will keep very much truer than if it were heated in the midst of the ignited fuel of the fire.

Fire-Fan.—This fan may be applied to any ordinary fire-grate, and it is almost impossible to imagine its power. A welding heat on inch iron in a common fire-grate may be obtained by its means.

The sides are formed of two pieces of sheet iron, the bottom of wood, length 1 ft. 3 in.; the nose may be made 6 in. long, breadth 2 in.; height $6\frac{1}{2}$ in. A is a wheel turning on a loose spindle, with lock-nuts for the end, to make a centre for the fan-spindle; B is a sheet-brass pedestal moving on a pin, with a spring at the

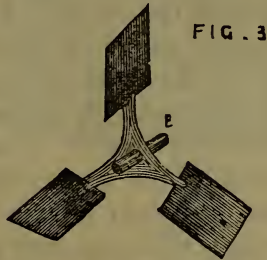
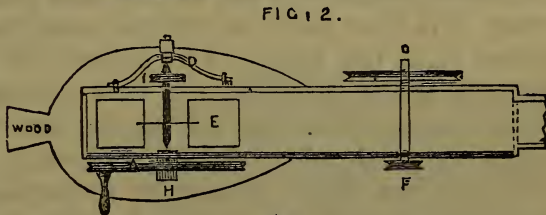
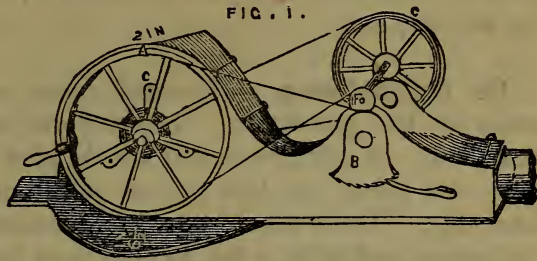

bottom to keep the belts in tension; C is a bit of iron, with three arms riveted on to the side—the centre takes the spindle H; D is a riveted arm to admit a large hole being made in the side, and to take a set screw for the other end of the fan-spindle; E the fan; FGI are wheels to increase the revolutions of the fan.

Hardening and Tempering Tools and Weapons.—The colour and temperature required in hardening the above-mentioned articles are as follows: For very soft temper, 630° Fah., colour greenish blue; pale blue, 610° Fah., for saws, the teeth of which are set with pliers; blue, 590° Fah., for

large saws ; dark blue, 570° Fah., for small fine saws ; dark purple, 550° Fah., for soft swords and watch-springs ; light purple, 530° Fah., for ordinary swords and watch-springs ; very pale purple, 520° Fah., for table-knives ; brown yellow, 500° Fah., for adzes and plain irons ; clay yellow, 490° Fah., for chisels and shears ; dark straw, 470° Fah., for penknives ; dark yellow, 470° Fah., for razors, &c. ; pale straw, 430° Fah., for lancets, &c.

On Grindstones. — Discard every contrivance for fixing tools on the grindstone ; they are one and all eminently unpractical. A grindstone will not do nice work unless it is kept true, and fixing the tool against it will of course wear it away unevenly. Tools should always be traversed across the face of the stone, and when a flat surface is to be ground by a circular stone, it is clear that this traverse must not be exactly straight across it, or the bevel will be hollow. A very slight hollow is perhaps rather an advantage than otherwise in such tools as chisels and plane-irons for wood ; but there are numerous cases where the face should be ground as flat as possible. This, as just stated, cannot be accomplished by keeping the tool fixed against the stone. Turning-gouges, again, must be continually swept round in a semicircle on the stone if the proper form is to be obtained ; and, whatever the tool may be, it should be continually traversed if the figure of the stone is to be preserved, which is a matter of the first importance where accuracy in the angles of the edges is aimed at. It is true that some workmen have a knack of producing wonderful edges on stones that run like eccentrics ; but this is a rare gift, and the bad state of the stones in many large workshops has much to answer for in the very indifferent character of the metal-turning to be found in them. Where all run to one stone, few take any care of it, and it becomes almost a practical impossibility to grind up a slide-rest tool with anything like the accuracy required for first-class toolwork. Regular grinders, however, know the value of a true stone, and are very careful in keeping them so. A true-running stone with a good face will make the workman independent of any rests and holders beyond his own arms and hands. It is true that goniostats are used for very fine and delicate tools where extreme accuracy of form is essential ; but these are generally

ground on laps running horizontally and presenting a plane grinding surface.

For amateurs' use nothing is better than a treadle grindstone about 20 in. or 24 in. in diameter; and if the tools are always traversed on it, and it is never allowed to *lie* in—or even over—water, it may be reduced 2 in. or 3 in. diameter by honest work, before it requires turning up again; and the operator will find, that when he has accustomed himself to grind true by hand alone, he will seldom want even a rest, and would certainly never think of spoiling his stone by using such an awkward and unpractical contrivance as a fixed holder.

Saw-Benches.—The following plan of a saw-bench will suit any possessor of a lathe. The box ABC rests on the bed of the lathe, and is kept in position by the tenon D fitting the lathe-bed, and fastened by the nut and screw EF. The platform G is hinged at the back to C, and in front is fixed by the three tenons of A—shown by dotted lines—and the hook H. I is the guide for the wood while being sawn, and which is always retained parallel to the saw by the parallel movement JK; it is secured by the nut M working in the slot N. The circular saw works through the groove O. This is a very simple and cheap method of mounting a circular saw; but a vertical machine is more convenient, as the friction is less.

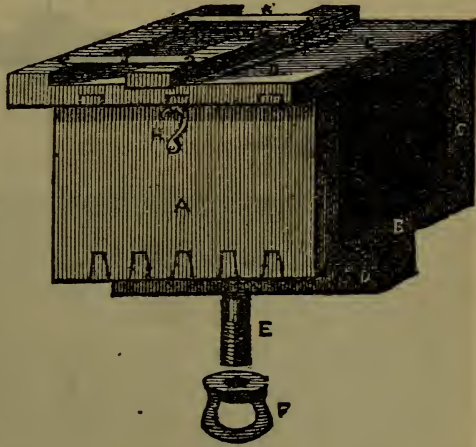

The top plate should be about 18 in. long by 12 in. broad, the spindle about 18 in. long by $3\frac{1}{4}$ in. thick; the small pulley 3 in. large, wheel about 30 in. in diameter and weighing about 56 lbs. You can determine the height of the bench by the wheel, which should work freely.

A is the edge of the iron plate. B and C the centre

screws for the spindle to run on, with nuts to lock the screws tight ; the sockets can be of cast iron for cheapness, and

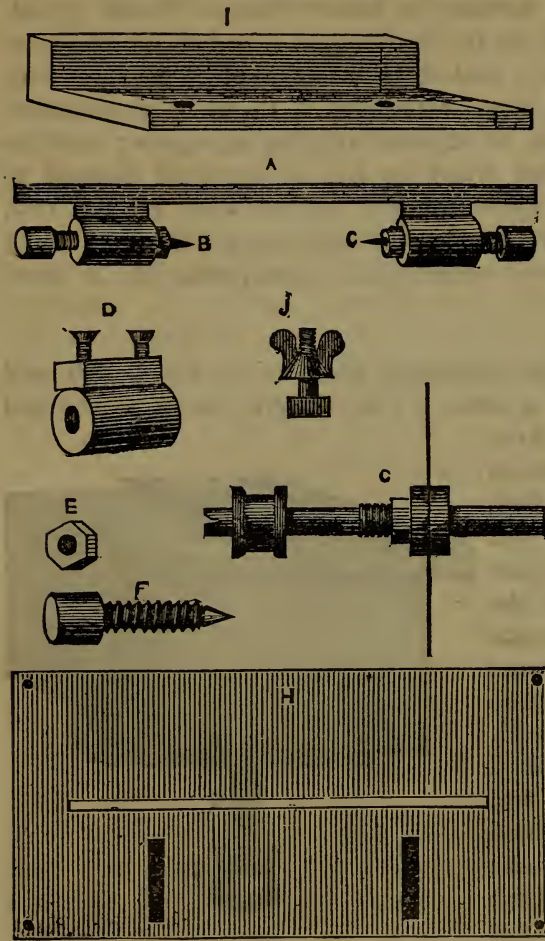

must be screwed on the plate from the front, which must be counter-sunk. D is one of the sockets with the two screws. E and F are the nut and centre screw ; the point must be of hard steel. G is the saw and spindle, which should be made of iron, with the ends drilled out cone shape to fit the screws. H is the iron plate with the slot for the saw to run in, which must be $\frac{3}{16}$ ths of an inch thick, and firmly screwed to the bench. I is the guide made of wood 9 in. long, with even face. J is one of the thumb-

screws with which to fasten the guide $\frac{3}{8}$ -in. screw.

Fret-Saws.—1. The following is run at a speed of from 300 to 500 cuts per minute, and the length of stroke of the saw is regulated, as will be seen in the drawing. When circles are required to be cut, adjust a clamp, with centre pin, to the saw-table, and set it to the required radius.

A, disc, with adjustable crank-pin for regulating the throw or length of cut. B, saw-table on a pivot C, and fixed by thumb-screw D. E, saw held in screw jaws. F, slide carrying

the elbow lever, and fixed by a set screw behind. GG, grooved pulleys. H, stretching band of crinoline steel, kept in tension by the slide F.

2. This fret-and-scroll saw is constructed on the following principle:—

A is the driving shaft which carries a fly-wheel B, a fast-and-loose pulley CD, and on the end of the same shaft B is a disc crank E. F is a connecting rod which communicates the motion to a slide-block G. At each end of the block G

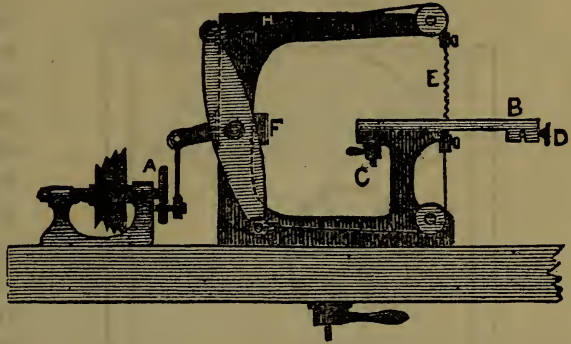

is fixed a rope H and I, which transmit the action to two other slide-blocks K and L, between which the saw-blade is fixed. MNOP are four guide pulleys for the ropes. Q is a hand-wheel keyed on a lifting screw R, which screw goes through a nut on which the pulley P is bolted fast; by this contrivance the saw-blade is tightened or slackened. S is a pin on which the table T is centred; on its bottom side is fastened a segment U, to change it to any angle required. V is the belt guard.

FIG. 1.

FIG. 2.

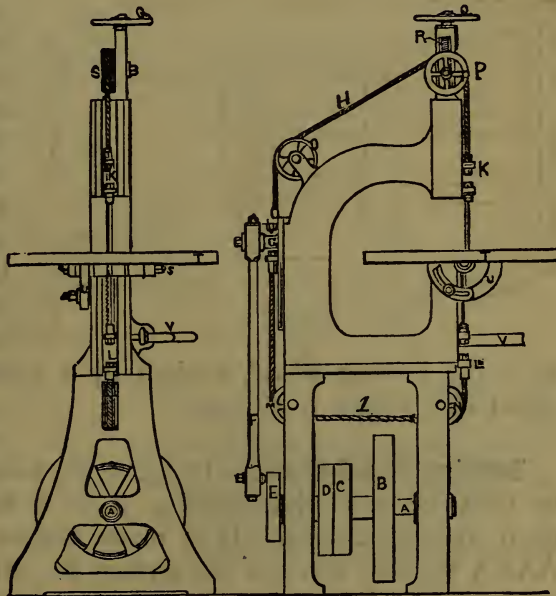

3. A vibrating fret-saw. Fig. 1 is a side view of the in-

ternal arrangement of the working parts.

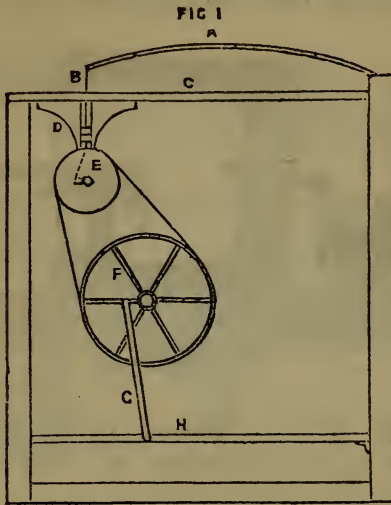
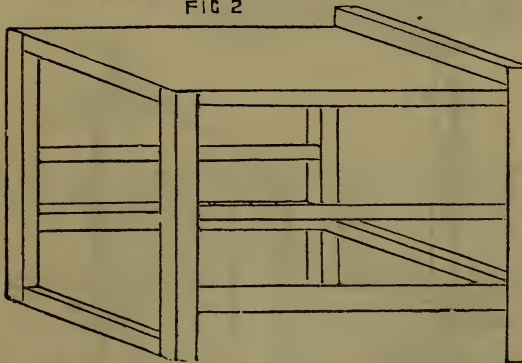

FIG 2



F is the driving wheel, worked by a crank with rod G and pedal H. Fig. 2 is a frame.

Brazing Band-Saws.—In fig. 1, G, a large cast-iron cramp to hold the saw while brazing it, is 3 ft. 6 in. long, a foot deep, and 3 in. wide. It is made hollow to allow the bolts AAAA to pass through the surface P. There is an open side left to get over this difficulty. M is the foot for resting on the bench; TT are two bolts for holding it to the bench. O is a recess planed in the surface, of $\frac{1}{4}$ in. wide, $3\frac{1}{8}$ in. deep, for laying the saw in, so that it just comes level with the surface. PK represents a vacancy for the tongs; it should be made

A is a flexible piece of wood strong enough to keep the saw B tight, lancewood or ash would do; it must be firmly fixed by the thick end to the frame; B is a fine saw; C is the table-top, made of $1\frac{1}{4}$ -in. birch, with a small hole in it for the saw to work through; DD are two V-faced guide brackets screwed to underside table and having a corresponding guide-piece, working betwixt them, to the top end of which is attached the saw, and the bottom end the rod, connecting it to a crank on the face of wheel E. It may be made with slot to alter the stroke to length of saw used.

just low enough to admit $\frac{1}{2}$ -in. square iron to pass nicely between the saw Y and the bottom of the recess A. You must place the open side of each iron cramp opposite to the way in which you are standing. That will then bring the recess O close to you, when, placing the saw Y on the cast-iron cramp,

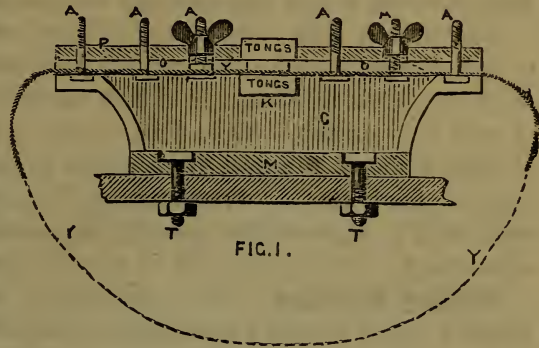

you will have the teeth towards you, and the blank part of the saw will rest against the shoulder of the recess O. You can let it lie on the ground when the bolt-cramp AAAAAA has got hold of the saw Y. The tongs used require to be $7\frac{1}{2}$ -in. square iron, and to come close together. A second pair of tongs are also required; they must fit nice and close, and must be $7\frac{1}{4}$ in. wide and $\frac{1}{2}$ in. thick; they are for laying hold of the joint after the hot tongs to keep it well together, and also to cool it. When commencing to braze, file $\frac{3}{4}$ of an inch off each end of the brass, and taper it down to nothing. After that, bring the filed ends over the vacancy K, one end over the other, put some spelter and borax in between, and then screw the saw Y down with bolt-cramps AAAAAA. Now everything,

is ready for brazing, get your tongs a white heat, put them over the joint, open, just to see how the brass is going on; when the blue flare rises, the brass has melted, and get some one to put the second pair of tongs on, when you can take the others away. Then loosen the bolts, cramp the joint from over the vacancy, and

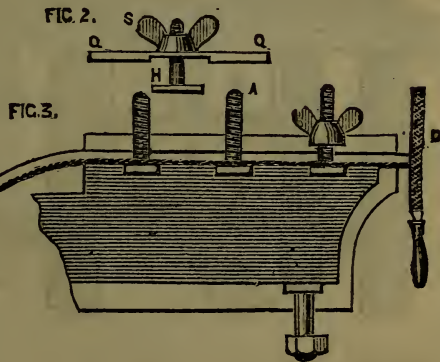

bring it farther up the recess O. Now it must be screwed down tight, and filed down to a uniform thickness, and you

will find a good strong joint; smooth, file, and emery the joint, so that it will slip through the wood.

Fig. 2.—A side view of one of the iron cramps. The dog Q is hollowed out in the centre, just leaving each end a little thicker. O is a fly-nut, H a bolt to pass through the surface of cast-iron cramp. Q is $\frac{1}{2}$ in. wide, 3 in. long.

Fig. 3 shows the end of cast-iron cramp, and how the taper can be filed at G. By screwing the bolts on to the saw you can hold it tight while you file it, which you will find a great advantage. In the plan, O is merely the file.

Sawing-Machine.—The saw-frame ABCD has a central wooden rod EF, and a saw-blade G and H on each side, which are stretched by nuts and screws at ABCD in the usual way. The saws are guided perpendicularly by the fixed rods IJKL;

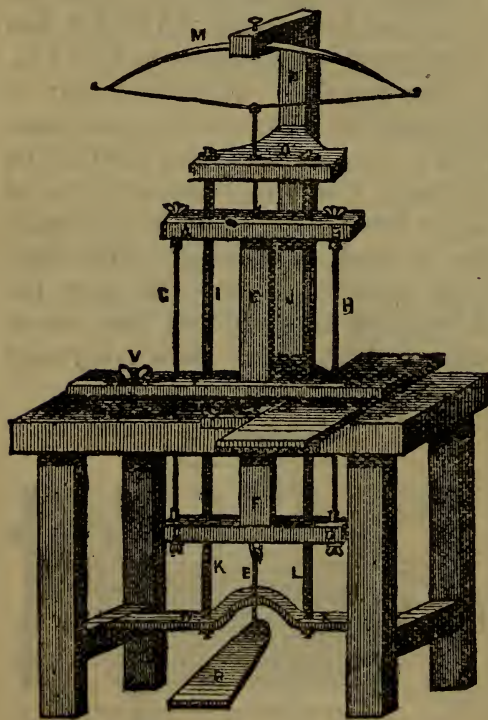

these pass through holes in the cross heads of the saw-frame AB and CD. The saw-frame is suspended from the steel bow-spring M, attached to the column N erected at the back of the bench, and which serves to support O and P, in which the upper guide-rods are fitted; the lower end of the saw-frame is connected by the hook Q with the treadle R.

For straight cuts a wide saw H is used, and the wood is guided against the square fence S, which overlaps the front edge of the bench, and is fixed by the binding screw T passing through a groove in the fence S. For circular pieces a narrow saw G is employed, and an adjustable centre point U, fastened by the nut V, and working in the stationary bar P, serves as an axis of motion for the piece of wood to be cut.

In order to have the bench unobstructed, so that large pieces may be sawn, the guide-rods IJKL, upon which the saw-frame works, are discontinuous, the lower pair only reach from the under-surface of the work-bench to WX; while the upper pair are fixed to the two cross pieces O and P attached to the column N.

The saws are kept steady by running in the saw-kerfs Y and Z, in the lower rail P of the guide-frame. The saw H is represented cutting a straight plank, and the saw G a circular piece.

Magnetic Lock.—This, which is known as “Nobody’s lock,” is without keyhole, with changeable key, and is useless to all but the owner. It should be made of brass, or some non-magnetic metal (the harder the better); the four circular metallic pieces, having the adjustable magnets centred rather tightly on them, are suspended on pivots, which allow of rotation with sufficient ease, and have each a groove (as seen) nearly to the centre, to admit the four prongs of the bolt (in unlocking), and the whole nicely balanced. There being no springs, and the bolt only required to slide easily, the handle must be allowed to turn in its centre when the force used would exceed what is necessary for the sliding of the bolt. This is necessary to prevent injury to the pivots of four circular pieces. These details, and some others, are not shown, as they will be readily understood. In the illustration, however, the hole is dotted as square for the sake of greater simplicity.

Lock shown complete, and the small handle ready to be turned, for withdrawing the bolt when the key (as set) is applied.

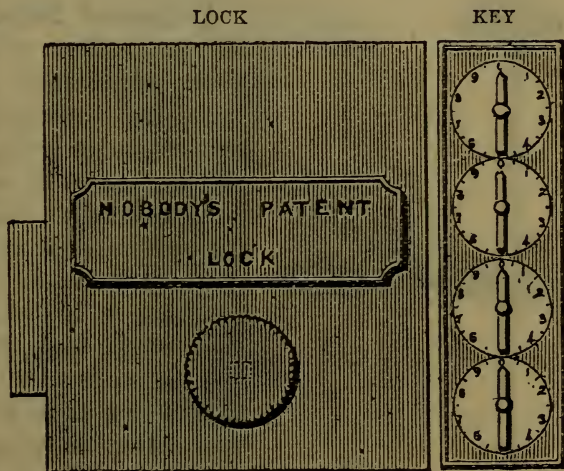

Key shown disarranged in a manner suitable for the conservation of magnetism, and being so applied to the lock (after the bolt is protruded by means of the handle) produces a like arrangement in the lock and the effect of locking.

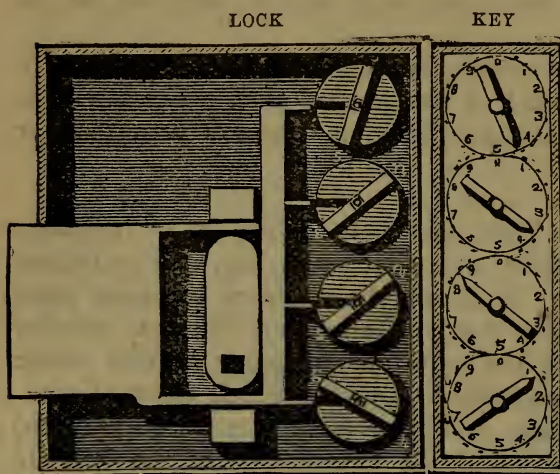

Lock with front plate removed to exhibit the interior mechanism, where the key, being supposed to be adjusted over the right-hand end, has rotated the magnets to the proper position, enabling the bolt to be withdrawn by turning the handle.

Key shown ready set by owner to turn over upon its proper

place on the lock, so as to cause the rotation of magnets as required to enable the bolt to be withdrawn. In the owner's memory the key would be set thus : $4\frac{1}{2}$, $3\frac{1}{2}$, $8\frac{1}{2}$, $1\frac{1}{2}$.

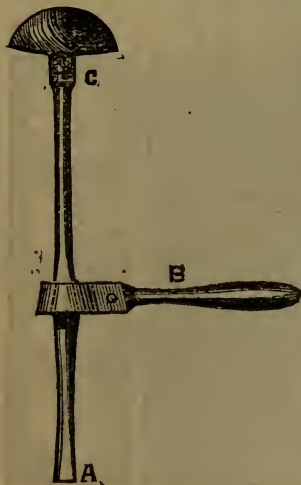

Improved Screw-Driver for large Screws.—This tool possesses very great advantages over the common ones, in consequence of its being worked by a lever, and having a revolving top. It is especially suitable for wheelwrights, railway-carriage builders, roof-makers, and will turn out twice as much work as the old ones. The following is a description : A is the point of the tool ; B is the lever, which can be made to fold up (when not in use) at the joint, as shown in the cut. The dotted lines near the joint are the four squares upon which the lever fits,

and while in this position, you draw it to you, then lift it up clear of the square part, and on to another, and so on. C the

head, is the same as a common brace-head, which you keep to your shoulder. The head-should be made of wood, and the other part of steel.

Improved Hand-Press.—Below is an adaptation for

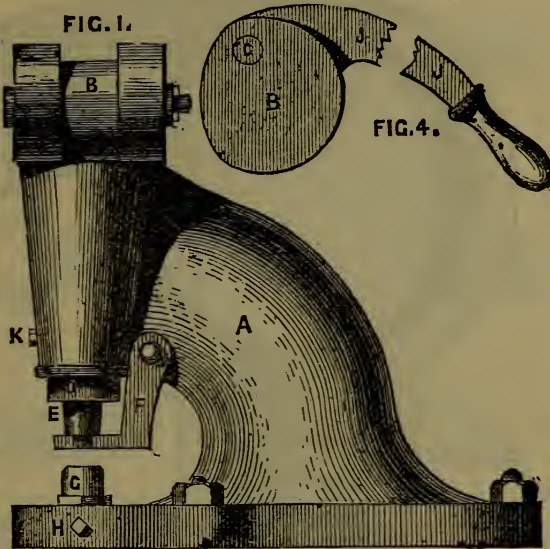

stronger work of the presses for stamping on paper.

By it you may punch holes $\frac{1}{4}$ by $\frac{1}{8}$ thick and larger, by simply pressing the lever down. In fig. 1 is a side view, fig. 2 a front view, and fig. 3 section showing the working parts. A is the body; B, eccentric lever; C, steel pin; D, steel spindle at top; E, punch; F, releaser; G, bed for punch; HH, two set pins for same; I, weight if required; J,

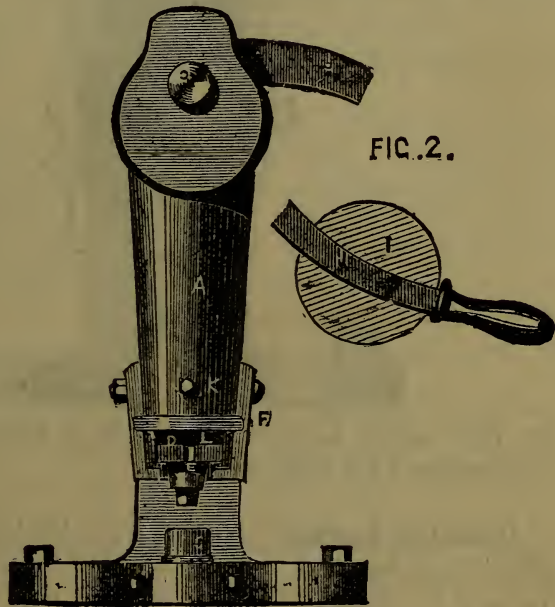

lever; K, peg to fit groove; L, to keep spindle steady; M, powerful spring to lift spindle up and release iron of the parallel nipple or punch. This compact little press would

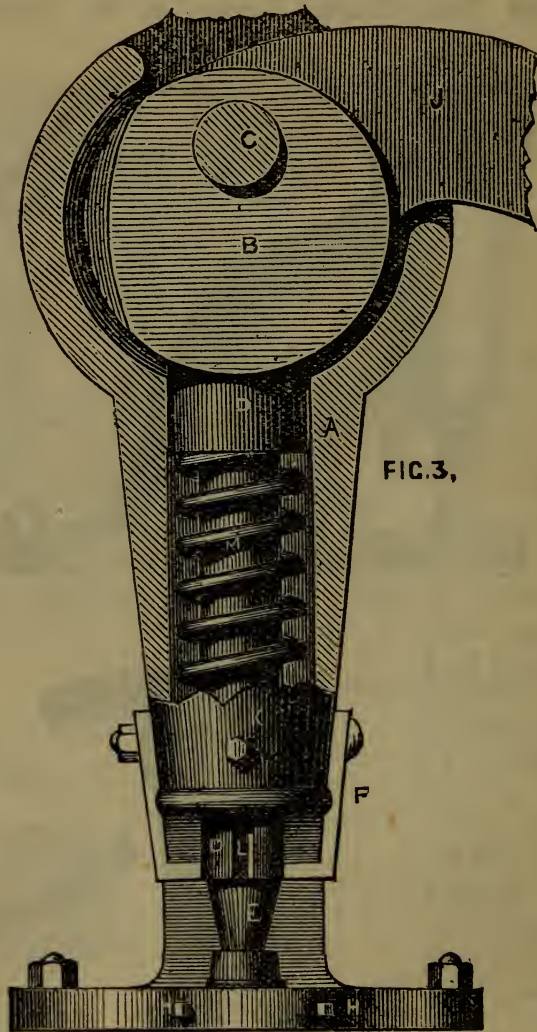
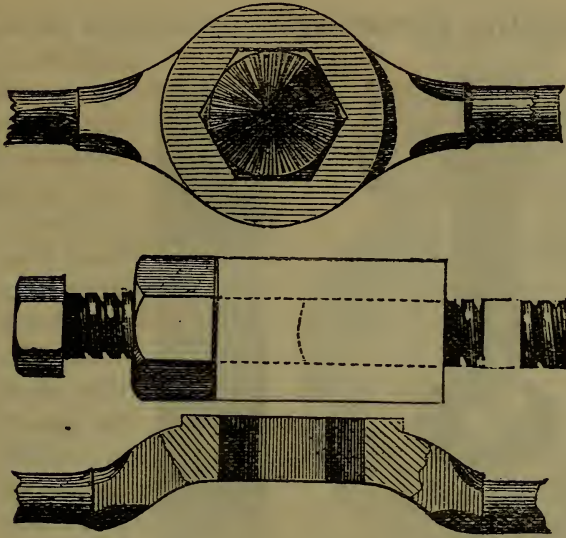

FIG. 3,

be very useful to many to whom a large one would be too cumbersome for light work.

Cleaning Lenses.—Neither wash-leather nor silk will answer after being handled. A roll of soft blotting paper put in a case to keep the hands from it is the best; velvet is also very good.

Stud-Box and Wrench.—A capital stud-box with wrench can be made on the accompanying plan.



Alloy for Journal-Boxes.—The following alloy has been found to answer excellently for journal-boxes: 4 lbs. antimony, 12 lbs. of tin, and 12 lbs. of copper. Having melted the copper, add the tin and afterwards the antimony. It should, after having been run into ingots, be cast in the form required for the box.

Leakage in Smoke-Box.—Insert in the end of tube a drift 4 in. or 5 in. long, turned to fit the tube, slightly tapered and hardened: two or three sharp blows on this will suffice; then run round with small caulking tool. If a bad leak in fire-box end, better take out tube as follows: Remove ferrule, chip off end of tube level with plate in fire-box, then with a drift (turned with a shoulder a little less than outside diameter of tube) drive it out from fire-box end, remove slate and scale, anneal ends, and replace (end to project in fire-box about $\frac{1}{8}$ in.), then drift as above. The ferrule, if not too thin, may be drawn a little larger, or replaced by a new one. If properly forged it will require no turning. Having driven the ferrule home, the end of tube may be riveted over to the plate; ferrules are unnecessary at smoke-box end. A dolly, or piece of iron to

hold on drifts, long enough to clear fire and smoke box doors, is necessary.

An Adjusting Carrier.—Here is a sketch of an adjusting carrier contrived by a workman in the employ of Messrs Holtzapffel. It is capable of holding anything from $\frac{1}{8}$ in. up to 1 in. diameter.

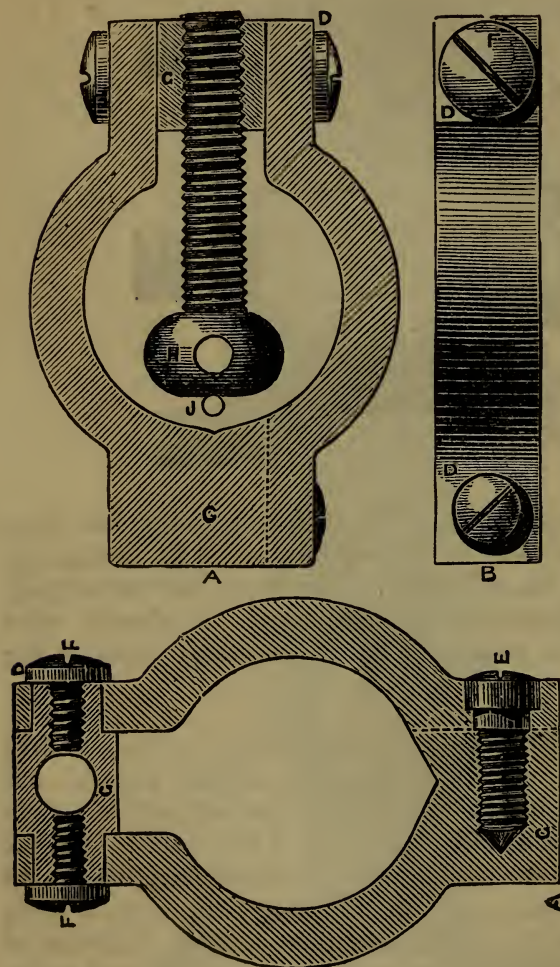

AAA is the front view, B the edge; they are made either in gun-metal, iron, or steel; CCC to the dotted lines are one and the same pieces; DDDD are separate pieces fitted to CCC at the bottom by screws EE, and at the top by screws FFF, which fit into a revolving steel nut GGG, the faces of the screws binding upon the faces of the nuts and the faces of DDDD, at one and the same time, just sufficiently tight to allow

of the nuts revolving uniformly, carrying the binding or clamping screws HH with it, the head of H¹ clamping the smaller diameter J and the end H². By this arrangement, it will be observed, that anything from $\frac{1}{8}$ in. to 1 in. diameter may be clamped without much loss of time in adjusting the binding or clamping screw HH upon the material

by turning round H into H², the position of, and *vice versa*.

Matrices for the Paper Process of Stereotyping.—The following is the process for making the mould for casting stereoplates by paper: Take a sheet of tissue paper, and having laid it on a perfectly even surface, paste on to it a soft piece of printing paper, pressing it evenly on to the tissue. Then lay the paper on the type form (which must be oiled), cover it with a damp rag, and beat the paper in evenly with a stiff brush; then paste a piece of blotting, and repeat the beating-in; then in a similar manner paste about these more pieces of tough paper, and back up with cartridge paper. Dry the whole with a moderate heat, under slight pressure. When it is dried, brush it well over with either French chalk or black-lead, and the matrix will be ready for use.

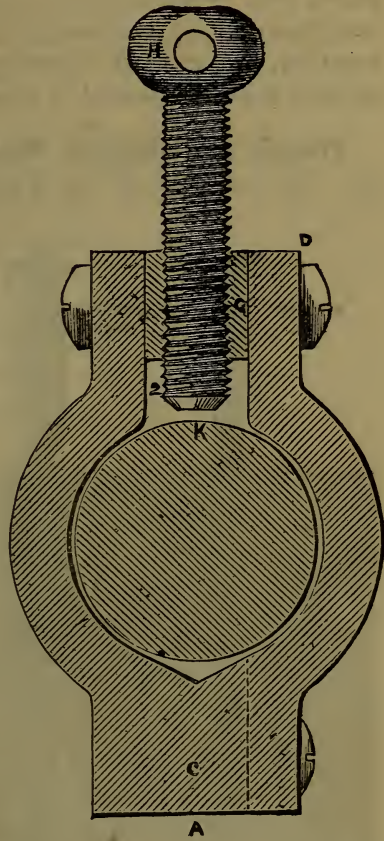

New Style of Pin.—The phrase “pin-money” is to us of modern days a meaningless term, but if we go back to the time when the expression originated we find it had a painful significance, for prior to the introduction of the machinery for their manufacture a pin made by hand was in value a synonym for a penny. Extravagance in the use of pins at the present day is incredible. The annexed engraving shows a new pin, which will remain in position when once placed, and not injure



the fabric. The improvement is in forming the shank with one or more swells or enlargements, beginning at or near the point, and terminating in square or bevelled shoulders; or if designed to be permanently placed, as in fastening papers together, the expanded portion is provided with barbed points, so that if once inserted it cannot be withdrawn.

French and English Nails compared.—A writer, asserting the superiority of French over English nails, says:

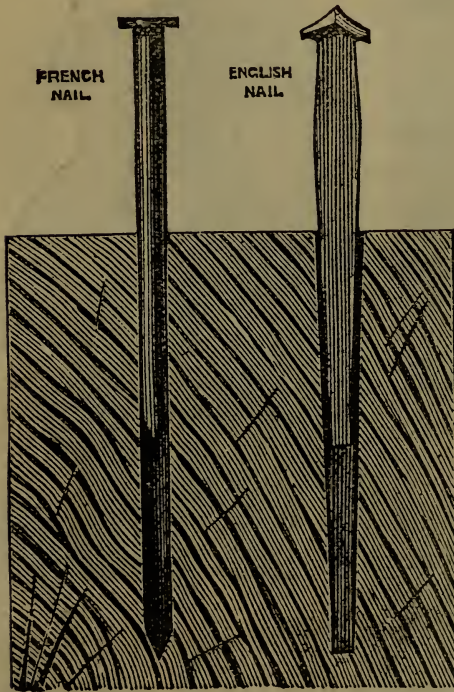

“The fault of the English nails is their being made in the shape of a wedge, which detracts from their holding power and makes them more likely to split the wood. The French nails are the same thickness all the way down, and have a sharp point, which is an improvement that the English makers seem to think quite unnecessary. The French nails are made of wire, they are less brittle than the English, and can be used over and over again without breaking. French nails have another great advantage, which is this, when an English nail is drawn out of its hole

to a certain extent, it (owing to its wedge shape) loses all power of holding, whereas the French nail holds to the last.”

Drilling-Machines.—Of late years much of the harder part of mining, excavating, &c., is performed by machinery; a description, therefore, of the principal instruments in use for that purpose will not be without interest to our readers. First we have the drilling-machine patented by Mr Newton. The invention relates to machines in which the working parts and bed are attached to an upright. The feeding of the drill is

produced by a weight applied directly to the drill-stock, regulated by an adjustable counterpoise connected to the drill-stock by a system of levers, which also raise the stock and drill above the work, to permit of the adjustment and removal of the work from the drilling bed; and it is in this counterpoise and system of levers and their connections that the first part of the invention lies. The second part of the invention consists of a bracket attachment, which, with the bearings in which the drill-stock works, are all cast in one piece and bolted to the standard. The third part consists in furnishing the adjustable bed-plate with a fixed jaw and a sliding jaw which works in fixed guides on the bed, and is adjustable by a screw for clamping the articles between the two jaws. The operation consists finally in constructing the standard and bed-plate with a recess for the introduction of large articles, without having the drill-stock, or the table or bed-plate, set out at a great distance from the face of the standard.

Drilling Holes in Glass, &c.—A practised man gives it as his experience that a splinter of a diamond is the best article with which to drill holes in glass. The splinters are mounted as in the diagram. A, brass wire, is made to fit drill-stock, sawn down a little way with a notched knife to allow the splinter to fit tight; B, the splinter of stone cemented by heat with a little shellac or sealing-wax. The drill is to be used quite dry and with care.

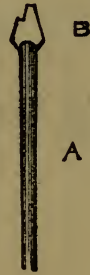

Rock-Drilling Machinery.—An improved drill has been invented by Mr Christian Jurgens, of Weber Creek, California, which consists of three angular cutting bits, having an obtuse point, thus giving it three regular inclined faces and three corners. When the drill has become worn and dull from use, the inventor uses a die, by means of which the smith may more readily and perfectly restore the drill to its original shape. In forming the original drill, the inventor uses a swage block, into which the bar of metal, after being heated, is placed horizontally, where it is hammered and turned until properly shaped to receive its cutting faces and points. This swage may be also advantageously used in repairing drills, and in keeping the drill in proper shape as it is gradually worn up by use and the requirements of new cutting edges. By the use of these

shaping tools a drill may be more perfectly and readily shaped and sharpened than in the ordinary manner of hammering on an anvil.

Alley's Drilling-Machine.—This instrument was introduced

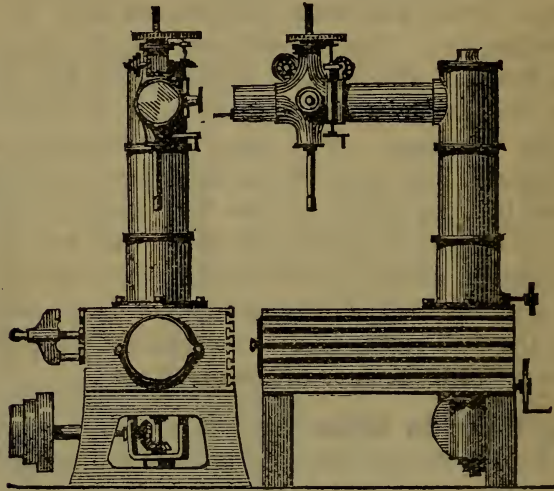

by Messrs Neilson Brothers of Glasgow, and was designed by Mr S. Alley of that firm. Its chief peculiarity is that nearly

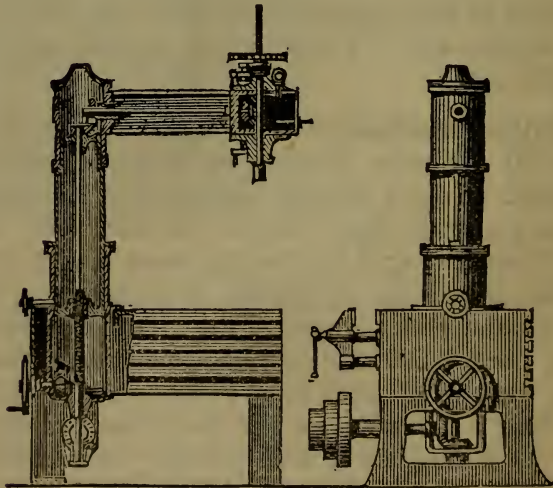

all the gearing is enclosed within the hollow pillar and radial arm, thus protecting it from the dust and from contact with

surrounding objects, whilst the tool as a whole is rendered very compact. The pillar, which is of the telescope form, is raised and lowered by hand in the smaller machines, but for larger sizes an arrangement represented in the sectional view is adopted. The wheel and screw on the top of the vertical pillar on the left-hand side of the main pillar is employed for raising a coupling on the driving shaft, by which means the

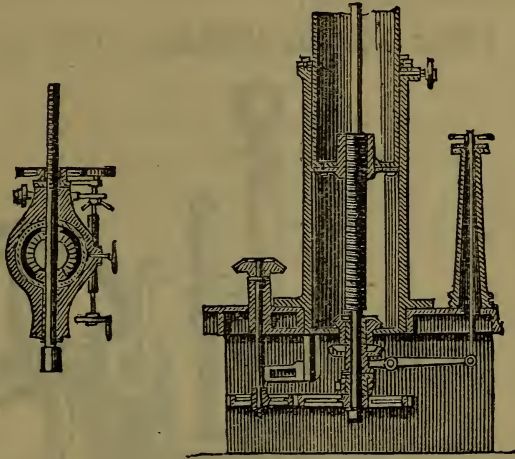

lifting screw is coupled to it. The drill-spindle is provided with a self-feeding motion, which can be engaged and disengaged by means of a friction-clutch. The other parts of the machine are so clearly shown in the woodcut that a further description is not required.

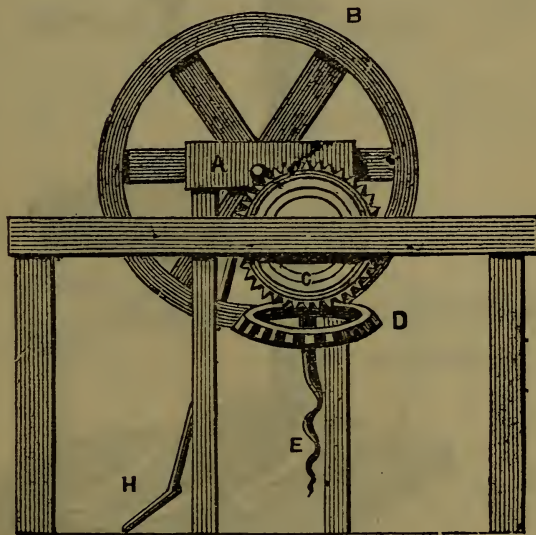

Boring-Machine.

—The following boring-machine is to be used where great power is necessary: A is a stand which supports the flywheel B. A cogwheel C revolves on the same axle as this flywheel, and turns another cogwheel D, which revolves on a pivot, to which is attached the auger E.

The flywheel is turned by the treadle and crank H. This would give sufficient power to the auger to bore through the thickest planking.

Pillar Drilling-Machine.—This compact and useful in-

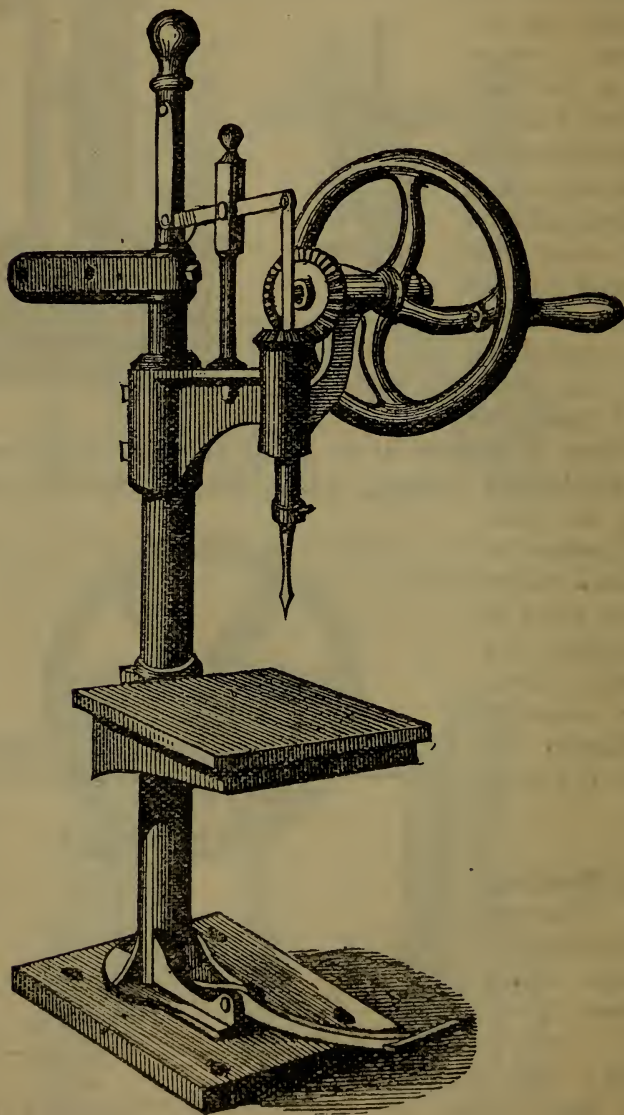

strument occupies a space of less than 2 ft. square, the height being only 5 ft. 3 in. It can be worked as advantageously by

steam as by manual labour. When worked by the latter, the pressure on the drill is produced by the feet, leaving both hands at liberty to hold the work and turn the machine. On removing the foot the drill is instantaneously lifted out of its work; the pillar being accurately turned, the table is easily adjusted to any depth, so as to take in articles not exceeding 2 ft. 3 in. in height. This pillar drilling-machine requires only one person to work it. The drill makes two revolutions to one of the hand-wheel, consequently, for holes up to $\frac{1}{2}$ in. diameter, it will drill two to one of any other machine, and when worked by steam power, it retains this advantage up to $\frac{3}{4}$ -in. holes.

Boring-Tools.—There are several boring-tools for wheels, &c., to follow up drills, or to finish holes left in the castings. The rose-bit is of very general use in boring out brasses for bearings. It is made of steel turned, filed into teeth, and hardened. Fig. 1 represents two forms.

Fig. 2 is the regular boring-bit of engineers; it is a

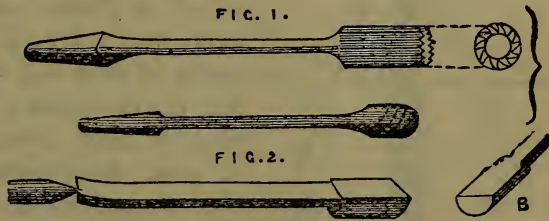

semicircular bit of hard steel shown more plainly at B; the other end is drilled to receive the point of the back centre of lathe, which keeps it up to its cut. Let the wheel to be bored be chucked, and after being drilled (if required) turn out a recess the exact diameter of the tool, thus: *ab* is the recess; *de*, top of rest; *c*, spanner of back centre. Then lay the tool in the recess, flat side up, place a spanner on the shank, which is squared, and let spanner lie on the rest so as to prevent the tool from turning, screw up back centre, and work away. Holtzapffel keeps the standard tools required.

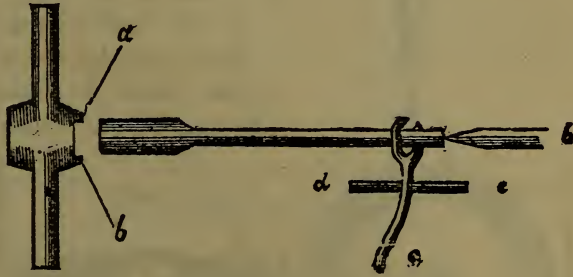

Sprinkling Book Edges.—Procure for red edges a pennyworth of Spanish brown, and for brown edges a pennyworth of burnt umber, and take sufficient paste to mix a quantity of either colour on a stone slab, adding, when well mixed, a few drops of sweet oil ; then put the mixture into an earthenware jar, and add some water to it. Before using it stir it well with an iron-bound brush, then twirl the brush well round in the jar, and strike it against a wooden rod, held in the left hand, till it throws fine spots on a piece of paper ; then proceed in the same way to sprinkle the book edges, taking care to wipe the wooden rod occasionally.

Home-made Drill.—A simple drill for small objects can be made, as shown below, for about sixpence. In fig. 1, AC is a shaft of common deal, thick where the fly-wheel is placed and tapering towards each end ; HE is the flywheel, also made of deal and weighted with lead ; KL is the wood ; and HF, HE, two rings of lead : instead of rings a piece of pipe flattened might be nailed on the circumference. Fig. 2, HZ, ZF, shows the breadth of the rings of lead ; S is the hole where the shaft is fixed. Figs. 1 and 3, NO is a cross-bar working on the shaft ; S² is the hole where the shaft passes—this must be loose ; N and O, where the twine is fixed ; PC is a wire wrapping to hold the bit (a small

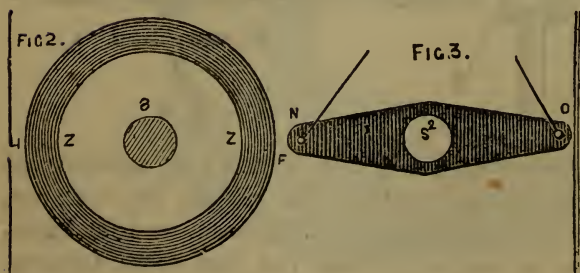

bradawl) firmly. The working is very simple. The twine NX, XO, must be fixed at X, and wound round the shaft a few times, which raises the arm or cross-bar to Y. Pressure must then be alternately applied and relaxed to the bar.

Grinding and Polishing Pebbles.—Pebbles are ground with a lead wheel and emery, the emery to be mixed with water to a paste and applied with a small brush; after they are sufficiently ground, the next process is smoothing. Work the emery on the wheel, it will soon smooth; if the wheel should get dry or blue, take a little more emery and another stone, and smooth it on the wheel and then finish off scratches. Now for *polishing*. Be sure and wash all the emery off before commencing this step. Polishing is done on a block-tin wheel with rotten-stone. All the wheels run horizontal, and are cast about 8 in. in diameter and turned true.

To Cut Brooch Stones.—If the pebbles are round they must be slit. This is done with diamond-dust, applied to the edge of a tin wheel with the finger, and then oil is kept on with a feather as long as you cut; after that, the stones are blocked to shape with a pair of soft iron nippers 6 in. in size, and then stuck on a stick and cut into shape and finished.

Vertical Drilling - Machine.—This small machine can be fixed upon the bed of a lathe, and worked by a small pulley on the flywheel shaft. A, the bed; CC, a wrought-iron pillar supporting the brackets BB; EEE, screws for holding the brackets; D, hand wheel for raising and lowering the drill; F, bolt to the end of the pillar C for holding it down to the bed of a lathe.

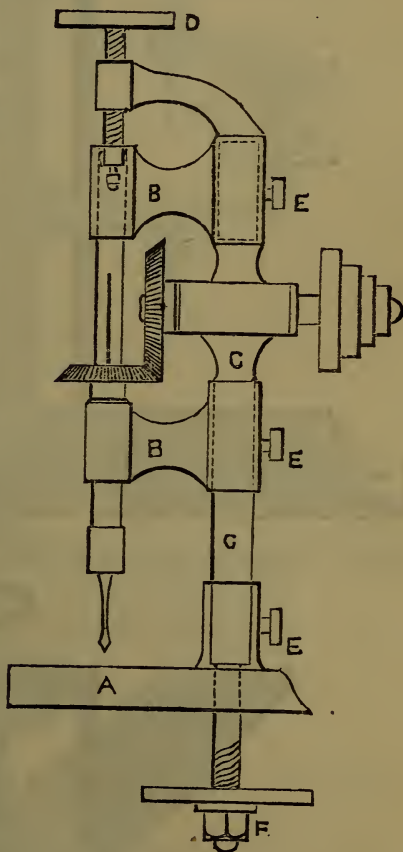

Another design is shown in annexed diagram.

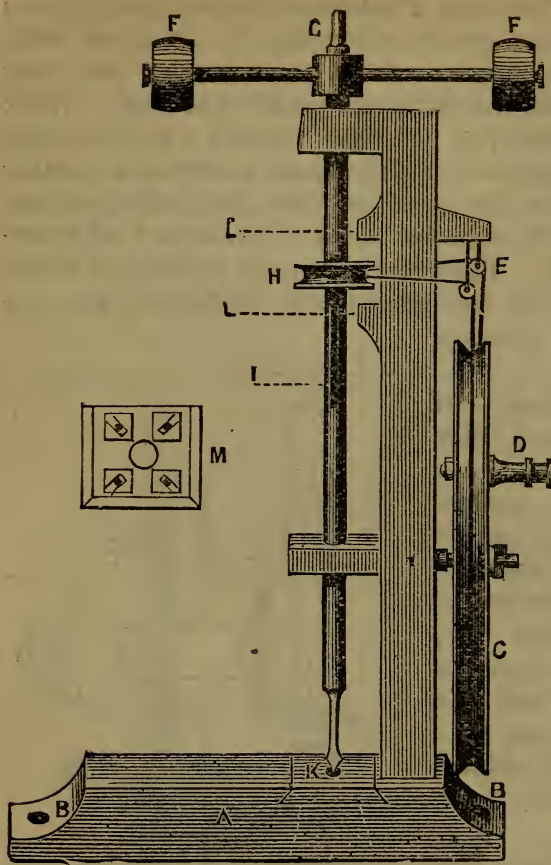

work ; L, blocks to keep pulley in position.

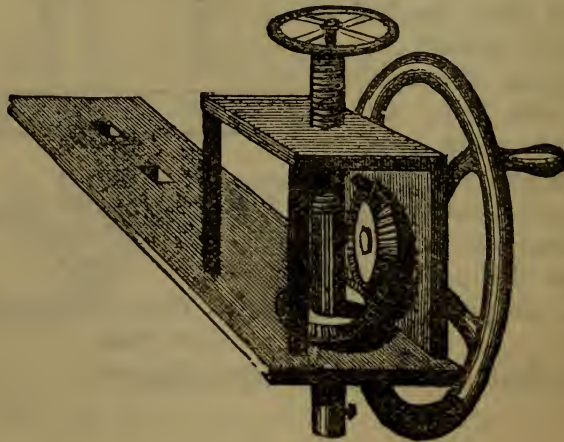

A is a stand of hardwood with upright and cross piece at top firmly fixed ; B, nuts to screw the whole to bench ; C, flywheel ; D, crank for treadle, or may be shifted towards the outside of flywheel, and act as a handle ; E, pulleys ; F, lead weights moving nearer centre if required ; G, pivot upon which extra weights may be placed ; H, pulley ; I, piece screwed on to work in slot in pulley ; K, dovetail, which may be removed and plate M substituted, in which the squares move towards the centre, and thus clamp the

Another simple machine is made as in above engraving. It can be made of any size to fix on the table conveniently.

Drilling-machines for stoves, &c., can be made thus :—

Fig. 2.

Fig. 1.

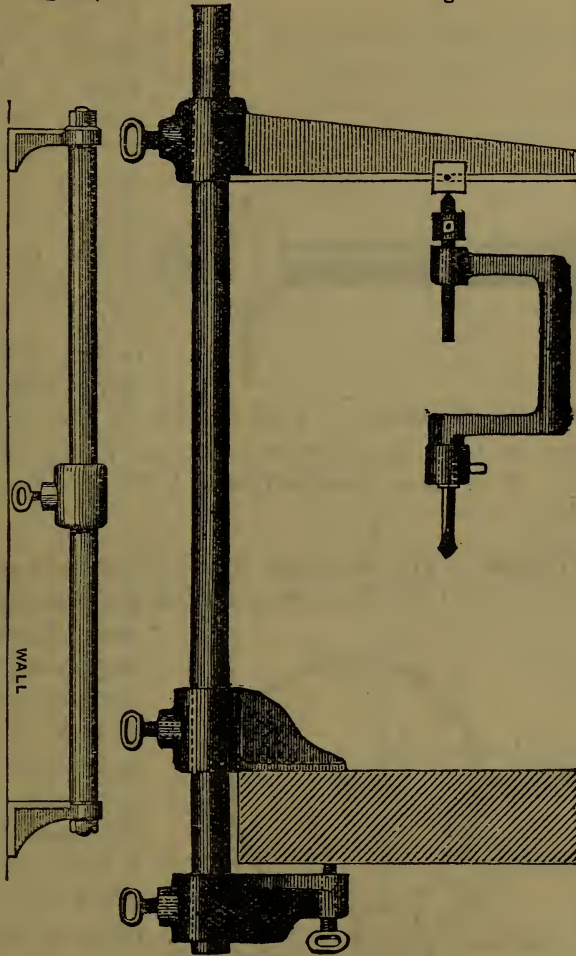
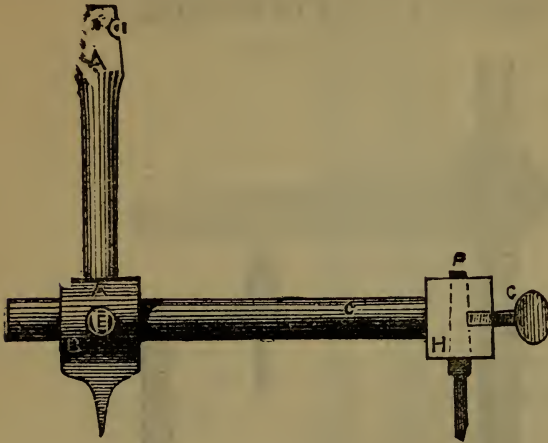

Fig. 1 shows the tool applied to a work-bench ; fig. 2 as applied to a wall.

Centre Bit for Cutting Leather Washers.—A is a piece of iron $3\frac{1}{2}$ in. long by $\frac{1}{2}$ in. square, tapered at the end to fit into a common joiner brace. The bit CI is to be filed out with a small round file for the catch in the brace to fit it. AA is a piece of iron 1 in. thick, 1 in. broad, 1 in. long, with a slot

$\frac{3}{8}$ in. square through it. B is the slot, D is the centre, the same as that of a lathe. CC is the slide, $\frac{3}{8}$ in. square, to fit in the slot. HH is a square piece of iron 1 in. long, $\frac{3}{4}$ in. broad, 1 in. thick, with a slot $\frac{1}{4}$ in. square through it. FF is the cutter that fastens in the head HH. G is a thumb-screw that fastens the cutter in the head. HH, the cutter, must be the same shape as a spear-point penknife-blade. The bit C1 in the cutter must be filed out so that the thumbscrew can fit in to keep the cutter fast. E is for a thumbscrew to hold slide from moving when used.



Water-Wheel.—The leverage in all the weight of water in the buckets from D to E is the same as the pressure of a column of water of corresponding dimensions suspended from D to F. The shorter column CE would be also equal to CF; but experience proves it to be advisable to throw all the force into a column of water, as above, with full buckets, rather than to expend velocity at a lower range, the intermediate buckets from C to E being only partially filled. This reasoning can apply only to a properly-made breast-wheel.

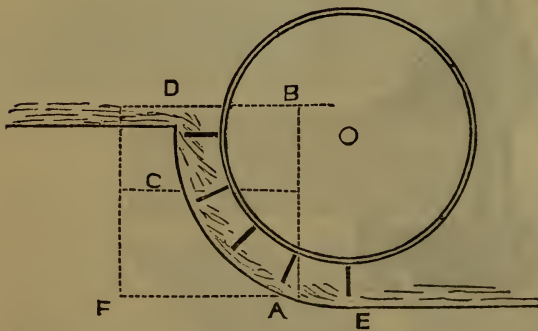

Cotton Waste may be thoroughly cleansed from oil and grease in the following way: It is put into an iron furnace (heated with steam from a pipe led into it), together with a

little black-soap and soda. The action given to the water by the rushing in of the steam keeps the waste continually moving, thus freeing it of its impurities. After boiling for about two hours, it is taken out and laid on a boiler or warm place till dry.

To Make the Ram of a Hydraulic Press Water-tight.—

The ram A is surrounded by a collar of leather D; the leather is formed as shown in fig. 3, being turned up to form a double cup, so that it resembles the cuff of a coat-sleeve. When in its place, it is kept distended by the copper ring E entering the circular channel or fold of the leather. This ring has a lodgment in a recess formed within the cylinder B. The leather is kept down by a brass or bell-metal ring C, which is received into a recess formed round within the cylinder B, as shown in fig. 1. The interior aperture of this ring is adapted to receive the ram A, and thus the leather becomes confined in a cell, with the edge of the interior fold applied to the ram A, whilst

the edge of the outer fold is in contact with the interior surface of the cylinder B. In this situation the pressure of the water acting between the folds of the leather, forces its edges into close contact with both, and makes a tight fitting round the cylinder and

ram; and as the pressure of the water is increased, the leather is applied more closely, so as to prevent leakage under any circumstances. The metal ring C is truly turned in the lathe, as well as the cavity or cell formed for its reception; then to get it into its place, it is divided by a saw into five segments, as shown in fig. 2. Three of the lines by which it is divided point to the centre, but the other two are parallel to each other, and the ring is put into its place (after the leather and copper rings are introduced) by putting in the four segments sepa-

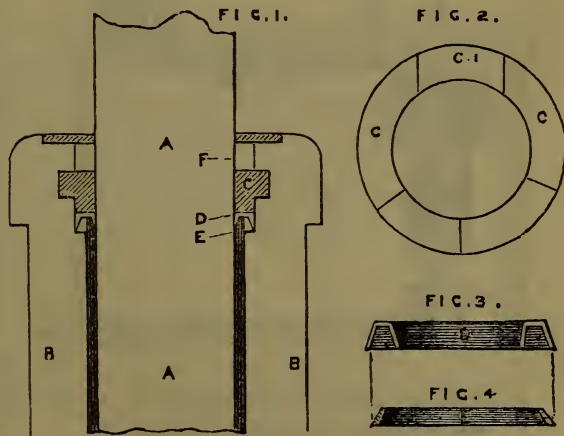

ately, and the one with parallel sides is put in last. The ram A is then put down in its place, and ready for action. The upper part of the cylinder above the ring C is filled with tow or other soft packing impregnated with sweet oil, which is confined by a thin plate or ring. A, piston or ram; B, cylinder; C, brass ring; C1, segment with parallel sides; D, leather collar; E, copper ring; F, oiled tow. The same letters refer to all the figures.

Air-Engine.—The principle on which this engine works is as follows :—

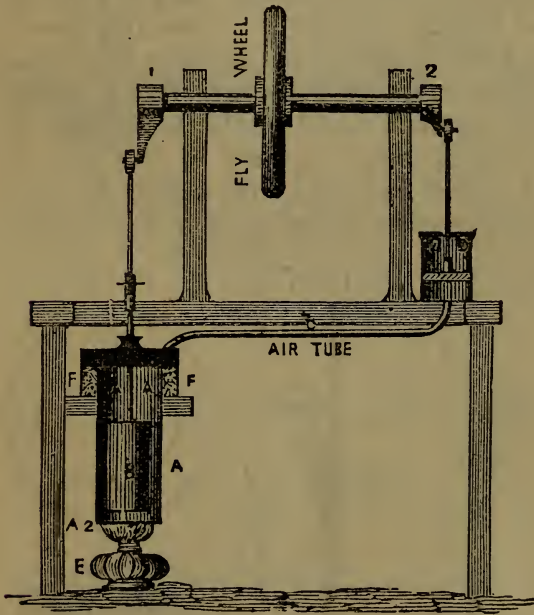

The air at the bottom of A is heated, and thus expands past the piston B, which is made to clear $\frac{1}{8}$ of an inch, reaches the top, where the brickdust cools it, thus causing a vacuum under piston in D, which draws it down.

A, main cylinder regenerator. Dimensions, $1\frac{5}{8}$ in. diameter, $5\frac{1}{2}$ in. long.

A1, top or cold end of ditto.

A2, hot end of ditto.

B, hollow piston working in A, $1\frac{1}{2}$ in. diameter, $3\frac{1}{2}$ in. long.

C, air-tube, connecting A with D.

D, working cylinder, 1 in. diameter, 19-16 in. long.

E, spirit-lamp or gas-jet.

F, casing round top of A, containing brickdust to keep down heat.

A, length of stroke = $1\frac{1}{2}$ in.

D, length of stroke = $1\frac{1}{4}$ in.

Syphon, the Principle of.—Let a bent tube ABC have its shorter leg AB immersed in any liquid—say water—having been previously filled with the same liquid. The water

will be maintained up to the level D by the force of the water in the vessel, and may therefore be left out of consideration.

The forces tending to move the water in the direction DBEC will be the pressure of the atmosphere transmitted through the water in the vessel, and the weight of water in the portion BC. The forces tending to move the water in the opposite direction will be the pressure of the atmosphere acting at the orifice C, and weight of water in the portion BD.

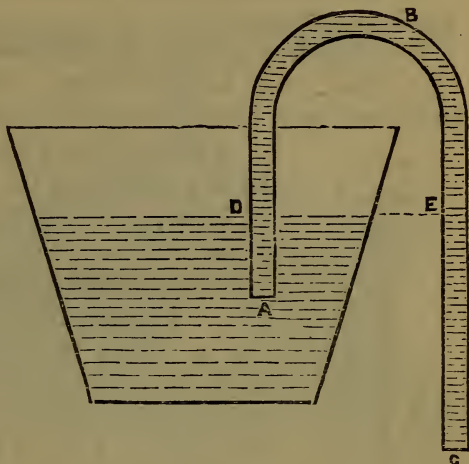

The pressures of the atmosphere being equal will neutralise each other, and there will be a tendency of the water to move towards C, in proportion to the excess of BC over BD.

A siphon will conduct water from a high to a lower level. It is a fundamental law in hydrostatics, that the pressure of a liquid upon any point is in direct proportion to the depth of that point below the surface.

Air-Pumps.—1. The following is a suggested air-pump. It has not, so far as we are aware, been tried. To work it, press the india-rubber dome, and let it return until the air is exhausted.

A, mahogany stand covered with a brass plate; B, receiver; C, india-rubber dome to act as pump; D, wooden pad to protect dome from the spring; E, steel spring to keep dome stretched out; F, brass cylinder on which dome is

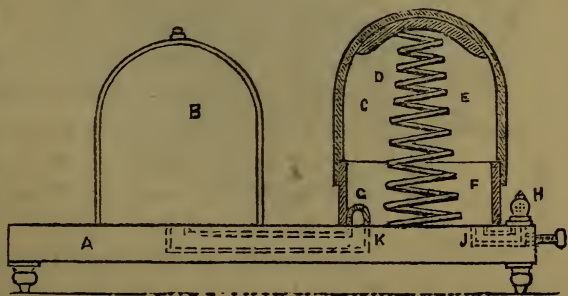

fastened ; G, valve to prevent return of air into receiver ; H, outlet valve, protected by brass cage ; I, screw to let air into dome ; J, outlet air passage ; K, exhaust passage.

2. The following plan will, it is asserted, answer well for small experiments :—

If applied to exhaust the air from a large receiver it should be applied only as a finishing pump, as the action is slow compared with many double-acted air-pumps.

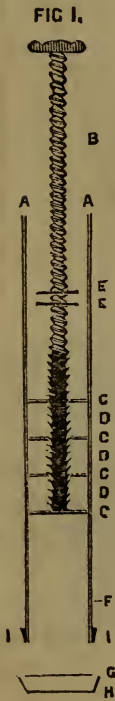

AA, cylinder of brass ; B, piston, which should have a thread all the way down ; CCCC, plates of brass, with DDD layers of vulcanised india-rubber (1 inch in the whole) between, which are kept firmly in place by means of the screws EE. F shows the situation of the tap, the working of which is shown in fig. 2. The tap, as there represented, should work right into the cylinder, but not to interfere with the action of the piston. G is a brass plate, and should be ground down so as to fit perfectly air-tight to the end of the cylinder and piston ; H is a brass cap for the purpose of holding on the brass plate G during the first move of the piston.

The pump should be worked in the following manner :—

Screw down firmly, by means of the nuts EE, the brass plates and layers of vulcanised india-rubber marked C and D in the diagram, to the bottom of the piston ; then, having forced down the piston to the bottom of the cylinder, which is made to fit level to the end of the cylinder, put the brass plate G, with a little grease rubbed on the inside face of it, against it—this will be kept in its place by the cap H ; then the tap being turned so as to open a communication with the receiver, draw up the piston the full length of the cylinder—this will remove a cylinderful of air from the receiver ; then eject

this quantity of air by cutting off the communication with the receiver and pushing down the piston. Repeat this process till a perfect vacuum is formed. [The above is interesting

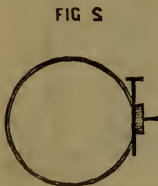

as a suggestion. We believe it has never been practically tested.]

Capstan Pumps for Hydraulic Presses.—The arrangement of pumps for working hydraulic presses shown by our engravings has been invented and patented by Messrs Peel of Manchester. The pumps are placed in a horizontal position, with their axes radial to the circle formed by the lid of the cylindrical water-cistern, to which all the pumps are fixed. All the pump-plungers are

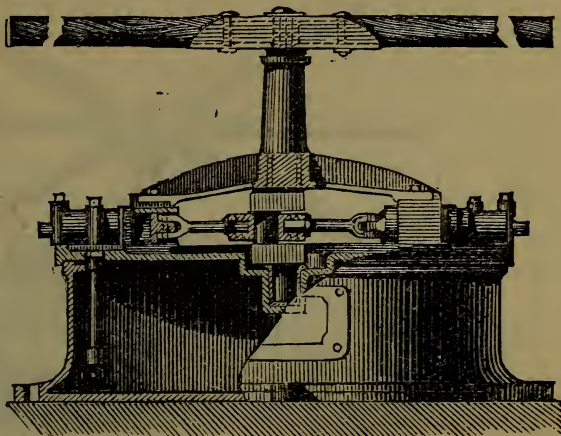

connected to an eccentric disc, keyed on to the vertical capstan shaft, which in this manner forms the crank for all of them, since at every revolution of the eccentric each pump completes a full double stroke. The pumps enter the corresponding phases of their movements in rotation, and divide the power very regularly all over the circle. The power is applied direct to the levers of the capstan, the form of which, as shown in the drawing, is intended for being worked by men. An arrangement is provided for throwing the greater number of pumps out of action

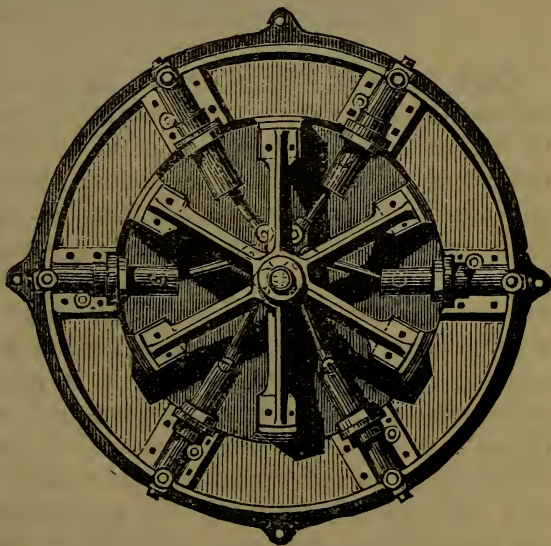

when the pressure increases beyond a certain point, so that the ultimate compression given to the bale can be increased by these means.

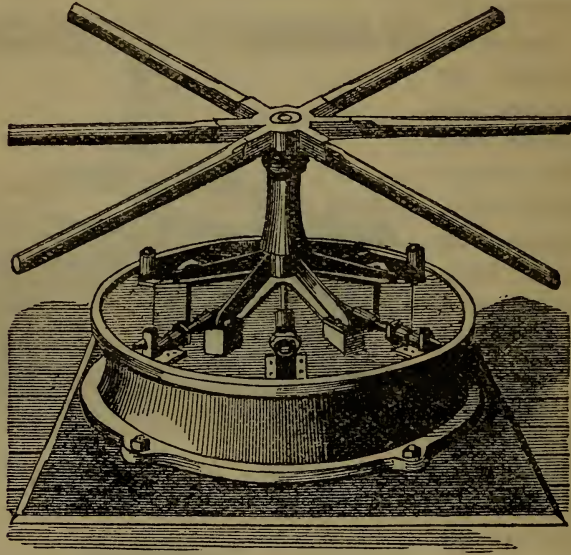

Cork Springs.—In a report upon new mechanical applications the secretary of the Franklin Institute called attention to the use of cork in place of india-rubber as a support for freight cars and like heavy vehicles. One would not be led by any means to predict the efficiency of cork in this connection from ordinary impressions of its properties. The cork used for these springs is of the commonest description, harsh, hard, and full of fissures. It is cut into discs of about 8 inches diameter, each pierced with a central hole. Previous, however, to cutting it, it is soaked in a mixture of molasses and water, which gives it some softness and renders it permanently moist. A number of these cork discs are placed in a cylindrical cast-iron box, a flat iron lid or disc is placed over them, and by hydraulic pressure is forced down so as to reduce the thickness to one-half. A bolt is then run through box, corks, and cover at the centre, and a nut being screwed on this, holds all in place, when the press is relieved, and the box of compressed cork disc or cork spring is ready for use. One of these springs, placed in a testing machine under a weight of

20,000 lb., shows an elasticity suggestive of compressed air in a condensing pump. One would expect, from the appearance of the material, that under heavy pressure it would be pulverised or split into shreds, especially if this pressure was assisted by violent shocks; but, in fact, no such action takes place. A pressure which destroys india rubber, causing it to split up and lose its elasticity, leaves the cork unimpaired; and with the machinery in use, it has even been impossible, with any pressure attainable, to injure the cork, even when areas of but 1 inch was acted upon. In connection with this subject, the president, Mr William Sellers, remarked, at the conclusion of the secretary's report, that he had for some five years employed a forging-machine in which a spring of the form and material above described was used, and subjected to continual and violent shocks, and that its performance had been most thoroughly satisfactory, with no signs of deterioration.

Camera Obscura for Drawing Objects.—The following sketch will be useful to amateurs wishing to construct a camera obscura. The best form of lens is a Meniscus (the focus for sketch 16 in.) with its convex side to the mirror, the diameter $2\frac{1}{2}$ in., the mirror 4 in. by 3 in. K is a hole to see the image. One of the sides is made to open, for the hand to draw the object. The height of the camera is 19 in.; the lens to be 15 in. from the bottom; the mirror to be as close to the lens as possible, at an angle of 45° . The mirror and lens should be made in a square box to fit in the top, so as to allow the sides *abc* to fall in, and *d* to form a lid.

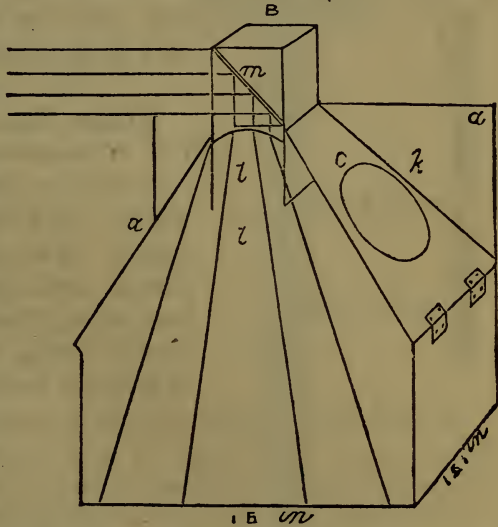

Pump for Deep Wells.—A model pump, made by an ordinary tinworker, is thus described:—

The barrel was about the size of a pint mug, the pipe was about 3 ft. long. Filled with water, it was found that the water in the barrel balanced the water in the pipe, and remained there by keeping the lower end of the sucking pipe under water; consequently, a pump fixed on the short pipe C would work with as much ease as though the water rose to the top of the well. A is an opening to fill it with, and while filling, the short pipe C must be stopped when full. Secure the opening at A, making it air-tight.

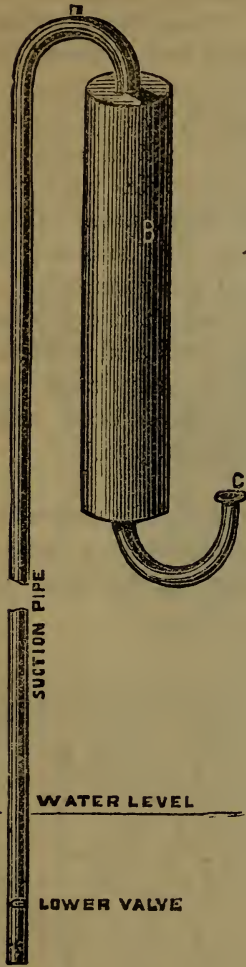

This pump will require a valve to act with the bucket. For convenience the barrel B may be put above, below, or half-way with the surface of the ground.

The opening at the top A may be omitted in a miniature model, as it will only be required for convenience in a large domestic concern.

Pump for Tube Wells.—During the Abyssinian War the Government supplied various kinds of pumps, of which the following was the best example. The whole apparatus is very simple and ingenious, being one of the numerous American inventions designed for the saving of labour, more especially in farming and mining districts.

A well on this new principle may be sunk in from one to three fathoms. The tube of the well is simply an iron gas or steam pipe $1\frac{1}{2}$ in. in internal diameter.

The lower end of the tube AB in the accompanying diagram is furnished with a solid steel or case-hardened iron spike B of the shape of a four-sided pyramid. The lowest end of the pipe itself is pierced by numerous small holes at N. After the pipe has been driven into the ground, a small pump is screwed into the top; the water, if present in the place, finds its way

through the holes at N, and may be pumped up to a height not much exceeding 28 ft., which is usually all that is necessary.

Not the least ingenious aspect of this useful little invention is the method of driving the pipe into the ground with the smallest expenditure of time, labour, and materials.

The movable clamp F is tightly screwed to the outside of the tube, above the level of the ground HK. Near the top of the tube, some distance above A, a similar clamp is fixed, which upper clamp carries two pulley-wheels for ropes. The same ropes also pass round the pulley-wheel DE of the monkey C. By means of the ropes a couple of men can easily pull the monkey C up the pipe, and suddenly let it fall upon the edges of the clamp F; and the force of each blow of course drives the pipe deeper into the ground. By successive blows the clamp F at last reaches the level of the ground HK, when it is unscrewed and refixed higher up the pipe. The upper clamp may be shifted in a similar manner, and in this way the pipe AB can be driven, if necessary, as deeply into the ground as a pump can raise water.

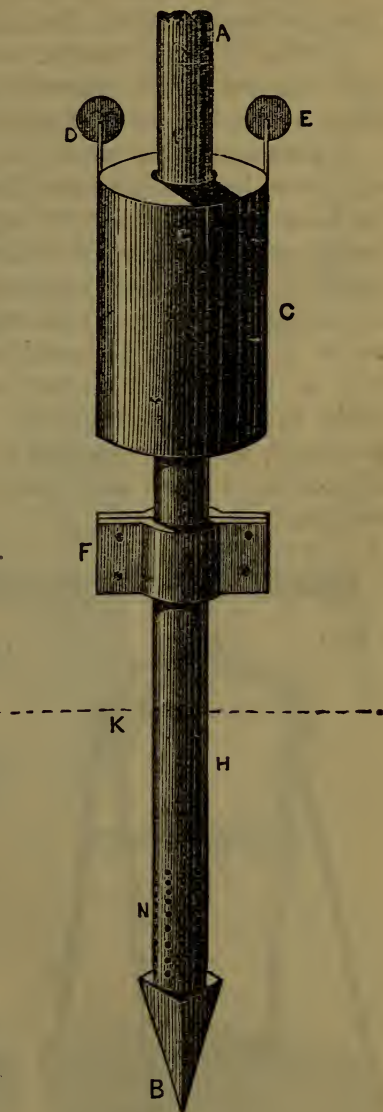

The advantages claimed for Norton's Patent American Tube Well, as it is called, are—

1. That it costs only a tithe of a bored or dug well, and saves water-rates, because by the 11 and 12 Vict. cap. 63, it

is enacted that no water-rates can be levied where there are pumps giving a proper supply of water.

2. That the water is purer than usual, because of freedom from the upper surface drainage.

3. That by this method wells may be easily made in loose soil, and the strata below may be pierced should there be no water at the bottom of the loose soil aforesaid.

A plan somewhat similar to this has long been in use to raise salt from its subterranean beds. Sir Robert Kane, M.D., in his book on "Chemistry," says: "Owing to the admixture of earthy matters, the rock-salt, as quarried, is generally brownish coloured, and hence requires to be dissolved in water and crystallised for use. The expense of extracting the salt may be in many cases lessened by simply boring down to the bed with a pipe a few inches in diameter, and letting thereby water run in upon the salt; a strong solution of salt is thus produced, which is pumped up and evaporated. The expense of sinking a shaft and quarrying out the solid salt is thus avoided."

Sack-Holder.—The diagrams below illustrate a simple and

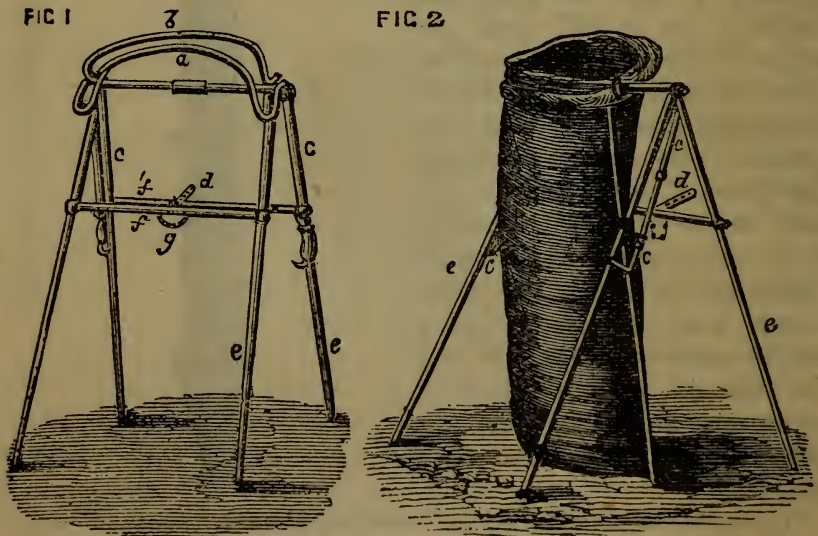

useful invention for sack-holding, inasmuch as it is the saving of a vast amount of labour and material. It possesses several

decided advantages, combining strength with simple construction and direct action. The height can be regulated as required by opening or closing the legs *ee*, being kept in the required position by the perforated plate *d*, which is fastened at *f*, passed through an opening in *f*, and is held by the iron pin *g*.

After adjusting the holder to the proper height, fold the back part of the mouth of the sack outwards, place it over the clamping-bar *b*, draw the spring arms *cc* forward, and place the hooks over *ee*; the sack will then be firmly held between the bars *ab* (fig. 2). In this position it

can be conveniently filled by one man, thus saving the labour of a second to hold the sack. When the sack is filled it is set free instantly by unfastening the springs.

By a simple modification of the above the "holder" may be adjusted on wheels, thus combining with it sack-cart (fig. 3).

It can also be fixed on beams or walls (figs. 4 and 5).

Diamonds, to Polish.—The plan in use at all the large diamond-cutters' is simply a circular cast-iron disc of good metal, with a vertical spindle running through its centre, balanced and turned and faced true in a lathe. The disc revolves at about 1000 revolutions per minute. With a little diamond-dust and oil the stone is set in a small brass cup filled with common soft solder; it is then screwed up in the clamps, and applied to the skive till the facet is formed.

To Fasten Driving Straps.—Two thin metal plates, their inner faces roughened like those of a vice, and held together by screws, form a cheap, strong, and convenient fastening for

FIG 3

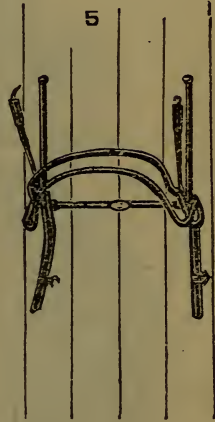
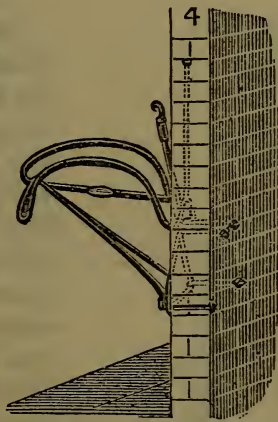
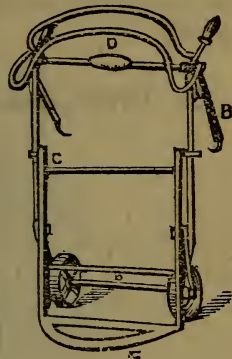

driving straps. If the strap stretch, the screws (which pass between the ends of and not through the strap) have only to be loosened, the ends of the leather cut shorter and clammed anew.

To Draw Radii to Inaccessible Centres.—The following instrument will be of use:

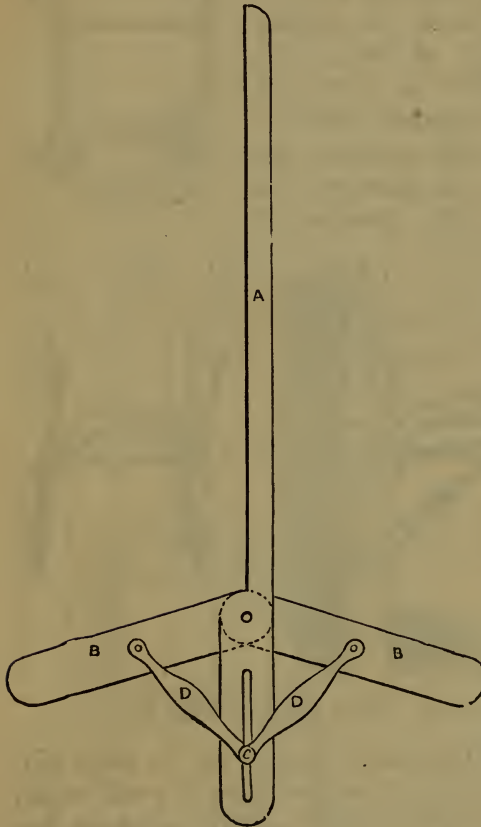

A is the blade with a slot in one end for set screw C to work in.

BB are the legs to run against cylinder, &c.

DD are radius bars to keep the blade central.

Bookbinding — Marbling.—Use the following colours: Scarlet drop lake, Chinese blue, indigo blue, ultramarine, orange lead, Dutch pink. Chinese blue can only be used by grinding with a small piece of pipeclay, and when properly ground, add a little gum arabic dissolved in water. Ultramarine blue, with a small portion of indigo, makes a good colour, and is less troublesome to manage, but does not stand so well. Green,

indigo and Dutch pink, mixed to the shade required. Red, use scarlet drop lake. All the above colours must be ground in neat gin, no water to be used either in grinding or afterwards. A few drops of ox gall must be put in each colour to make it spread on the size. Use the colours about the thickness of treacle.

Size.—This is the principal ingredient in marbling, and therefore requires much attention. Use the best gum drachan,

which should be white and clean ; soak a handful in soft water for twenty-four hours, beat well up with a roller, then add water until about the thickness of cream ; pour through a sieve into your trough, let it stand to clear, add a little salt, and it is ready for use. For non-pareil marble use the same size, but thinner ; and in grinding the colours, add a little bees-wax dissolved in turps.

Gas - Generator.—

Procure a half-gallon jar capable of standing a good pressure, then turn a cap to fit the neck with a screw inside, as N ; then the headpiece P, with a screw at S to fit into N, the head to contain a tap moved by a handle H, when the water will be forced through the glass tube A, which must be connected with the opening O, and reach to within $\frac{1}{2}$ in. of the bottom of the jar. To

work it, fill it three parts full of water, then add $\frac{1}{2}$ oz. each of carbonate of soda and citric acid, or a sufficient quantity to generate gas enough to force the water up through the tube.

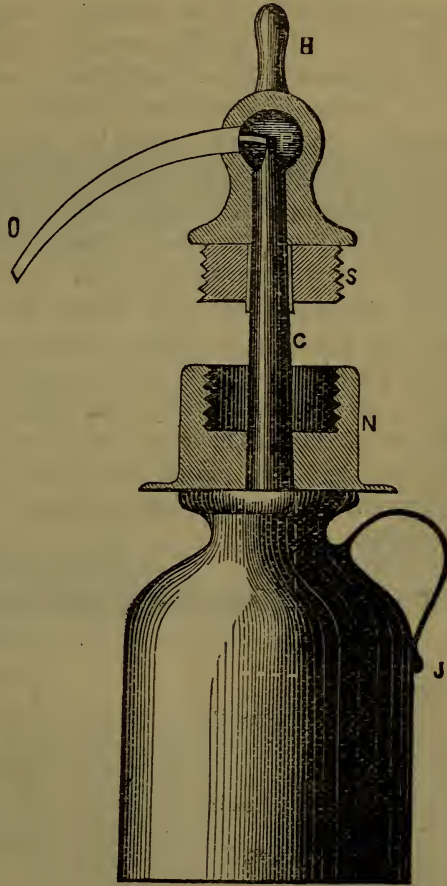

Papier Maché.—The substance known as papier maché is extensively employed in the construction of tea-trays, picture-frames, &c., and even railway carriages. There are two kinds—the pasted sheets and the macerated. The latter, which is the

more common, is made of paper cuttings boiled in water, and beaten in a mortar till they are reduced into a kind of paste, and then boiled with a solution of gum or size, to give tenacity to the paste, which is afterwards formed into different articles by pressing into oiled moulds; when dry it is varnished and polished. The black varnish for papier maché toys is thus prepared: Some colophony, or turpentine boiled down till it becomes black and friable, is melted into a glazed earthen vessel, and thrice as much amber in fine powder sprinkled in by degrees, with the addition of a little spirit or oil of turpentine now and then; when the amber is melted, sprinkle in the same quantity of sarcocolla, continue from time to time to stir them and to add more spirit of turpentine till the whole becomes fluid, then strain out the clear through a coarse hair bag, pressing it gently between hot brands. This varnish mixed with ivory-black, in fine powder, is applied in a hot room on the dried paper paste, which is then set in a gently-heated oven, next day in a hotter oven, and the third day in a very hot one, and let stand each time till the oven grows cold. The paste then varnished is hard, durable, glossy, and bears liquors hot or cold.

Wheeled Skates.—The following sketch is sufficient to



allow any clever mechanic to make a pair of wheeled skates that can be used both in and out of doors, on any level ground. They are fastened on the feet with a strap from heel to instep, and a couple of straps across the toes. A screw passes into the heel, at the back instead of the bottom, as in the ordinary skate. The skate itself is formed of iron, slightly curved to fit the foot, and rolls upon four little

wooden wheels, with indiarubber tires.

Omnibus Register.—Various plans have been from time to time suggested for registering the number of passengers carried

in and upon an omnibus during the day. The present plan of expecting the conductors to mark down each "fare" upon a card is confessedly incomplete, and the more simple one of

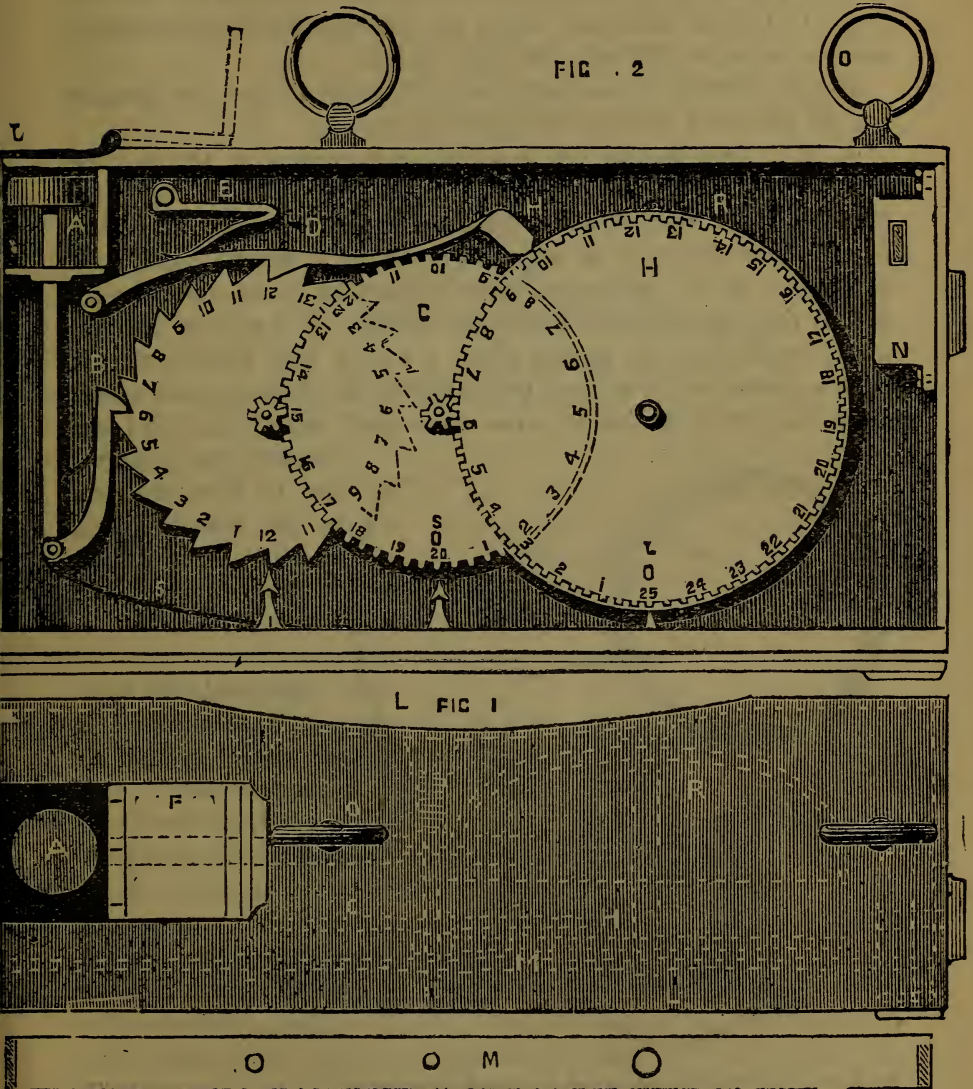

Omnibus Passenger Registering Machine.

giving each passenger a ticket from a numbered book does not seem to have suggested itself to the omnibus proprietors. The following apparatus for registering the number of passen-

gers conveyed and the amount of money taken has been invented by Mr R. H. Thomas of Kidsgrove, near Birmingham.

Fig. 1 of the diagrams is a $\frac{1}{4}$ -size plan of the machine closed ready for use, to be suspended under the left arm by the two rings OO to a shoulder strap, the hollow side next the body, and the cover C towards the right hand.

Fig. 2 is an elevation with the front plate L and the bearing bar M removed to show the movement.

A is a thumbstand on a sliding rod jointed at the bottom end to a ratchet hook B and a spring S; C is a cover for protecting the stud A when not in use, but is turned up to the dotted lines when it is required; D is a detent click and hammer; E is a spring to force it down in the ratchet teeth, and at the same time to strike the bell R; F is a plate ratchet wheel numbered for pence, from 1 to 12 and from 1 to 12, with a pinion on its arbour, which drives the shilling plate wheel G, with another pinion to drive the pounds wheel H; III are

three indicators pointing to the numbers on the wheels F, G, and H; R is a bell on the arbour of the wheel H.

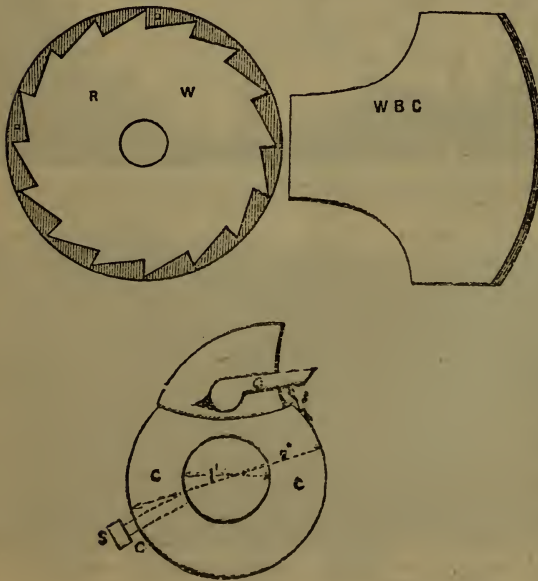

Ratchet-Wheels.

—RW, ratchet on end of wheel nave, both cast together; CC, a collar on the shaft end which works inside of nave; C, a movable catch kept in its place by the small spring S. The collar answers for two purposes—viz.,

to keep the wheel on and to work it round. D is a set screw to fasten a tin cap on end of nave or boss of the wheel; SC is a set screw to fasten the collar on the shaft; WBC, the wheel boss and cap fitted on over the ratchet. The ratchet is a rim by itself, and may be cast at rights and lefts.

Cutting out Bowls.—An inspection of fig. 1 will show that after the first groove is cut, a very long straight hook can be placed beside the centre block, but it would be impossible to place it for the edge to cut. But in fig. 2, a small tool, figure 1, is shown in position, and it can be brought to touch, cut the block, and when gradually advanced till the shank of the tool touches the block, will be undercut to the dotted line. Then you can place 2 so as to begin to cut, it is so placed to commence where the other left off; by the time this has been advanced the block will be undercut to the second dotted line. Insert a longer one in the same way till the block falls out. With curved hook tools wooden bowls are thus cut out one from inside another, so as to have no waste.

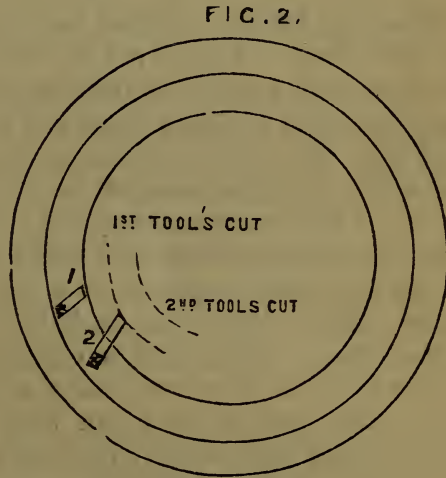
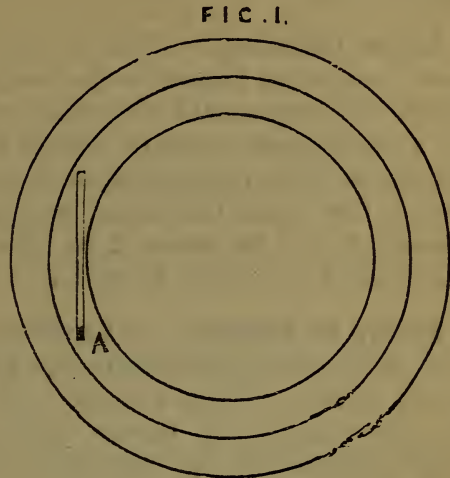

Ivory Bleaching.—Should antique works in ivory become discoloured, their original whiteness may be recovered by exposing them under a glass shade to the action of the sun's rays. If a piece of sculpture is disfigured with cracks, although these defects cannot be removed, they may be rendered much less apparent by brushing them over with soap-and-water. The process of bleaching will be much accelerated if before exposing

to the sun, the articles are brushed over with calcined diluted pumice-stone.

Ivory Cleaning.—Rub it with finely-powdered pumice-stone and water, expose to the sun whilst moist under a glass shade, and repeat until the whiteness is restored; or immerse for a short time in water slightly mixed with sulphuric acid, chloride of lime, or chlorine, or it may be exposed in the moist state to the fumes of burning sulphur, largely diluted with air. Ink-stains may be removed by repeatedly using a solution of quadrozalate of potassa in water.

Ivory, to Soften.—Dr Lankester recommends phosphoric acid, of the usual specific gravity, which renders ivory soft and nearly plastic. When washed, with water, pressed, and dried, the ivory regains its former consistency, and even its microscopic structure is not affected by the process.

Dyes for Ivory.—Billiard-balls and other articles in ivory are often dyed. A good red dye may be given by first imbuing the ivory in a solution of nitro-muriate of tin, and then plunging it in a bath of Brazil wood and cochineal. Lac dye may be used with still more advantage to produce a scarlet tint. If the scarlet ivory be plunged for a short time in a solution of potash, it will become cherry red. To dye a purple the ivory must first be mordanted for a short time in the above solution of tin, and then immersed in a logwood bath. This gives a violet colour. When the bath becomes exhausted it imparts a lilac tint. Violet ivory is changed to purple by steeping it a little while in water containing a few drops of nitro-muriatic acid. The aniline dyes can only be used for mauve and magenta, but unfortunately they soon fade. To dye ivory green it must first be dyed blue by immersing it for a longer or shorter time, according to the depth of colour required in a dilute solution of sulphate of indigo, partly saturated with potash. Afterwards dipping the blued ivory in the solution of nitro-muriate of tin, and then in a hot decoction of fustic. By omitting the indigo bath the ivory will be dyed a fine yellow. Ivory takes the dyes much better previous to polishing. Should any dark spots appear, they may be cleared up by rubbing them with chalk; after which the ivory should be dyed once more to produce perfect uniformity of shade. On taking it out of the

boiling hot dye bath, it ought to be immediately plunged into cold water to avoid the chance of fissures being caused by the heat.

A simple way of dyeing old billiard-balls is to procure a piece of thin, fine-faced scarlet cloth, wrap it tightly round each ball, being very careful to have as few creases in it as possible, and boil in water till the colour has reached the required depth. Rough-faced cloth will give the balls a mottled appearance.

Another plan is to take 2 ounces of verdigris and 1 ounce of sal-ammoniac, grind them well together, pour strong white wine vinegar upon them, and put your ivory balls in. Let them lie covered till the colour has penetrated.

Saving Life on the Ice.—Below is a diagram of a proposed raft to be used in rescuing persons from drowning consequent upon the breaking up of the ice. It is constructed upon the well-known plan of the toy regiment of soldiers. It



might be made of battens 5 ft. long, 4 in. by 2 in., bolted together, having a few friction rollers; and irons turned up at ends similar to skates. By means of the two ropes it could be worked from the bank, and got into any desired position with great facility. Such rafts would be very useful to cover any weak place on the ice, and one or two extended would be effectual in keeping it clear of skaters. The whole would occupy about 5 ft. square, and when extended would form a raft 50 ft. long and 4 ft. wide.



Vellum Cleaning.—Muriate of tin, oxalic acid, binoxalate of potash, of each $\frac{1}{2}$ ounce; powdered pumice-stone and cream of tartar, 2 ounces of each, and water 2 pints. Put all together and allow to remain till the oxalic acid and binoxalate of potash are dissolved. Shake well up before using, and rub well the bindings with it, by means of a sponge or piece of flannel, till clean. The bindings should turn out nearly white. Ink-stains will mostly be taken out. It will be well not to try to do too much at once, as more good may be done by applying a second time, in a day or two, after the books have got dry.

Parchment Cleaning.—Strain the parchment tight with the finger and thumb over a ruler, and “shave” it out (the very same action being used as when shaving the face) with a very thin sharp knife. The two principal difficulties in this are, not bringing the pieces clear off, and thereby leaving jagged ends; and bringing them too clear off—*i.e.*, making holes. When he has mastered this the amateur will be able to cut out a line or two, if he likes, and it will be scarcely visible unless held up to the light.

Tortoiseshell, to Polish.—Handles and similar work are first sawn into shape, then filed and scraped with a joiner’s scraper; afterwards polished on a buff wheel, first with calcined Trent sand, and finished on another wheel with oil and rottenstone. Flat works are treated in a similar way with flat pods. Turnery works are smoothed with fine glass or emery-paper, and finished with rottenstone and oil. Horn is treated in the same way, but the sand need not be calcined.

Cutting Hinges.—Amateurs will find the following plans useful for cutting the concave parts of hinges: The holes *aaa*, fig. 1, are first drilled to admit the steel rod, fig. 2, which has

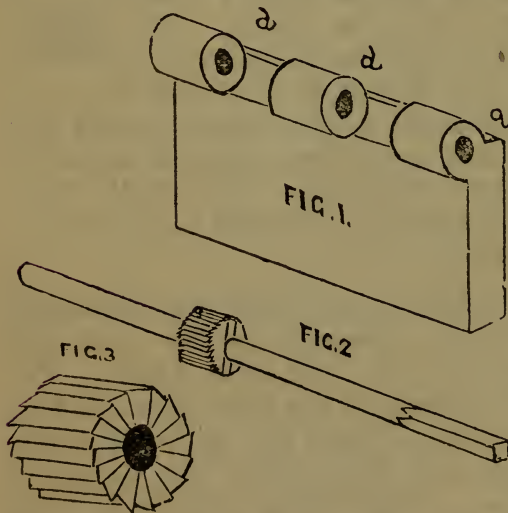

one end squared to enable it to be turned by a hand-vice. On this rod fits the cutter, fig. 3, which is a cylindrical piece of hard steel bored to fit the rod, and cut with teeth on the outer cylindrical part and on one flat surface; a pin is inserted through both the cutter and bar, so that the two may be united after they have been placed within the joint to be worked. A

recess must first be cut to admit the cutter, and then the hollow parts of fig. 1 are cut throughout their length with the cutter, which afterwards serves to flatten the faces of the knuckles in exact parallelism throughout and at right angles to the central

hole. For cutting the knuckles and tenons for the small joints of mathematical instruments, &c., such as fig. 4, the work is usually supported on a small iron platform, the surface of which is horizontal, with a notch to receive the saw B (worked by the lathe) and a cylindrical stem C to adapt the platform to the bed-piece of the common rest. This platform is fixed a little below the axis, in order to place the knuckles exactly central to the saw, so as to make the notches equally deep on both sides, and if the surface of the platform is parallel with the axis

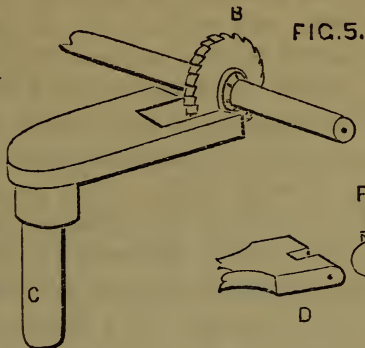

of the spindle, the notch is sure to be square with the side of the work. For fig. 4, E, two saws are used upon the same spindle to ensure the parallelism of the sides of the middle piece or tenon. Fig. 6 will also answer the same purpose without a lathe, by passing a pin through the centre hole and working it backwards and forwards in the hinge to be finished.

FIG. 4.

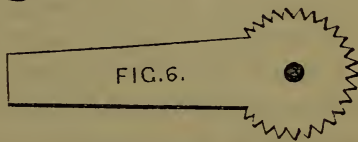
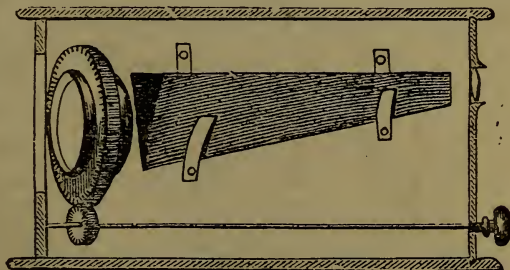

FIG. 6.

Kaleidoscope.—Below is a suggested improvement upon the old style of kaleidoscope. It claims to be better inasmuch as the body of it does not require turning. The objects change by turning the small shaft that drives the wheels. The large one is only a toothed rim, into which is fixed a tin case with a glass at each end, between which are fragments of coloured glass. The whole is fitted in a box with ground glass at one end and a convex lens on the other.



The simplest form of kaleidoscope consists of a cylinder of

tin, in which two plain rectangular mirrors of polished metal, or of glass having the back blackened, are fixed at such an angle of inclination to each other as may be obtained by dividing 360° by the numbers 3, 4, 5, 6, 7, 8, &c. The cylinder is covered at one end with a circular plate of metal, having a small hole in the centre, while a rim of metal is fitted over the other end, which is so constructed that two circular pieces of glass may be fixed in it at a short distance from each other, having some pieces of coloured glass, beads, lace, feathers, &c., in the space between them. The piece of glass that is placed at the extreme end of the cylinder should be ground glass, so that while the light is admitted into the interior of the instrument, external objects may be prevented from becoming perceptible to the observer. An angle of 60° is perhaps the best angle of inclination for the mirrors, as it may be readily determined, and affords a sixfold repetition of the pattern, which presents a tolerably uniform appearance of colour in all parts. If the angle of inclination be greater than 60° , the pattern will not be multiplied to so great an extent, but if less, although the pattern will be repeated a greater number of times, it will lose considerably in brilliancy at and towards the parts where the reflections of the pattern meet by the frequency of the

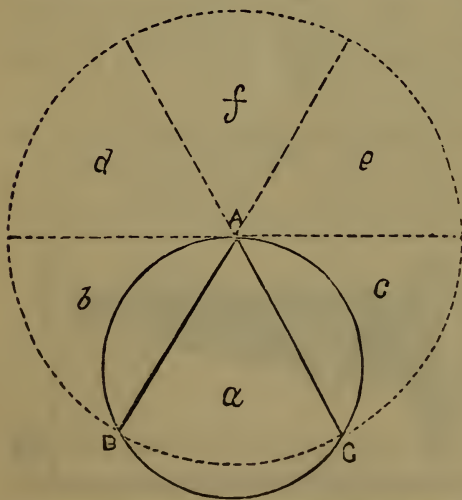

multiplication. In some kaleidoscopes the mirrors are made trapezoidal in form instead of rectangular, the broader ends being placed at the lower end of the tube.

The principle of the kaleidoscope will be understood from the accompanying figure, in which the smaller circle ABC represents a section of the tube of the instrument, and AB, AC sections of the mirrors, which are represented as inclined to each other at an angle of 60° . The objects in the space α between the glasses are seen directly by the eye, the part of the pattern in the space β is formed by the

reflection of the objects in the space a , in the mirror AB; and the part C, by the reflection of the objects in the space a , in the mirror AC. These reflections are again mutually reflected by the opposite mirrors, and form the part de of the pattern while the images reflected in each mirror for the third time unite in the part f , so as to form a corresponding appearance to the other parts. It is manifest that unless the angle at which the mirrors are inclined be accurately determined the reflections will not coincide, and the pattern will not be complete in the part f .

Kaleidoscopes are made in which the angle of incidence of the mirrors may be varied at pleasure, and by the aid of a lamp and a system of lenses in connection with the instrument, the pattern may be projected on a screen in an enlarged form, like the image thrown from a slide in a magic lantern. A pleasing effect of a similar nature, in which the images of the original object are multiplied and produced in different directions, may be produced by fitting the edges of three, four, or six trapezoidal mirrors together, so as to form a hollow prism, and putting them into a tube similar to that in which the two mirrors of the ordinary kaleidoscope are inserted. Instruments of this kind, which were invented by Dr Roget, are called polycentral kaleidoscopes.

Bevel - Wheels.

—To strike out a pair of bevel-wheels.

The following is the method of finding the taper or bevel for any line or angle: Let the line AB represent the shaft coming from a wheel, draw the line CD to intersect the line AB in the direction intended for the motion to be conveyed, and this line CD will represent the shaft of

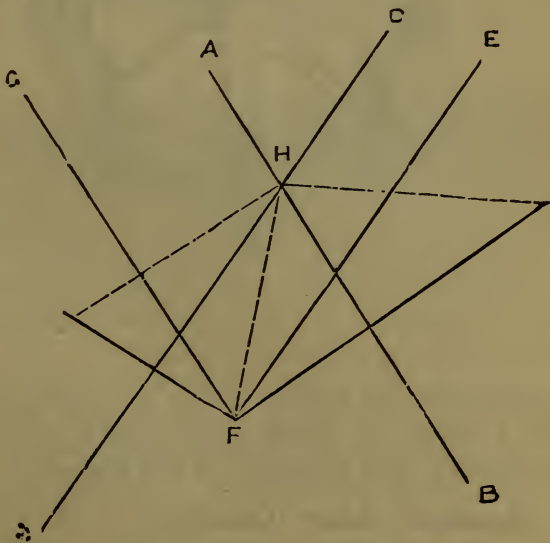

the bevel-wheel which is to receive the motion. Suppose, then, the shaft CD to revolve three times whilst the shaft AB revolves once, draw the parallel line FE at any moderate distance (suppose a foot by scale), then draw the parallel line FG at 3 feet distance, after which draw the dotted line FH through the intersection of the shafts AB and CD, and likewise through the intersection of the parallel line FE and FG, to the point H, then FH will be the pitch-line of two bevel-wheels.

Feathering Float.—The following design for a feathering float of a paddle-wheel is stated to have the following advantages:—

The float keys are in a vertical position during an entire revolution of the wheel ahead or astern, thereby making a clean feather.

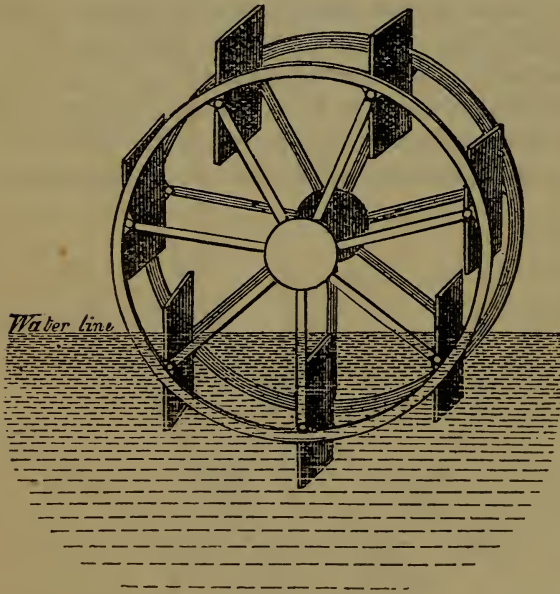

The paddle-wheel is no heavier than the oldest style of paddle-wheel. It has also a journal-bearer at the extremity of the shaft, which is a decided improvement on the present patent feathering - float wheel.

Suppose a ship to lose her rudder. When all other means of steering are lost, the ship

can be steered by this wheel by angling the floats by means of a handle or wheel conveniently placed on deck, without interfering with the speed of the engines.

Amateur Lens Grinding.— The process of grinding lenses for telescopes, cameras, &c., is much more simple than is usually supposed. If you wish to grind a lens for a telescope, first determine the length of focus and diameter of lens for the

object glass, and make a drawin gon paper ; you will then find by the drawing the thickness of glass required. We will suppose you commence on a small lens of $1\frac{1}{2}$ inches diameter and of 15 or 18 inches-focus. You must draw two short lines parallel to each other $1\frac{1}{2}$ inches apart, next open a pair of compasses to 5 inches and draw a portion of that curve between the lines, as in fig. 1. Next procure a piece of plate glass of the thickness shown by the drawing, and nibble it round with a pair of pliers, using a circular piece of paper as a guide. Smear one side of the glass with pitch, and stick it on a cylinder of wood of the same diameter and 3 inches high ; the crown lens will then be ready for grinding.

The tools for grinding are either of iron or brass, brass being best. Take a piece of thin zinc twice the width of the lens, and with the compasses at 5 inches describe a portion of that curve across the zinc, and separate the zinc at the curve ; you will then have a couple of patterns to get the brass tools made by. If you do not possess a turning-lathe, go to a wood-turner's and get two patterns made to fit the zinc gauges ; the patterns must have a stud on each, as in fig. 2, whereby to fasten a bit of wood with pitch, to act as a handle. After the patterns are cast in brass they ought to be again turned to fit the gauges, and finally rubbed together with emery until they fit each other. An amateur need not have the tools much larger than the lens.

Next procure from an emery-grinder three kinds of emery, $\frac{1}{4}$ lb. of the finest washed emery, 1 lb. fine-grained emery (a little coarser than flour of emery), and 1 lb. coarser still. Begin and rub the glass with the coarse emery with water, using the hollow brass tool until the glass is ground of the same curve as the tool. At this stage you will not be able to see through it, because of the great hollows dug into it by the particles of the coarse emery. Therefore wash away all coarse particles and rub again with the next degree of emery, which will put a finer surface upon it. Wash all this off the glass again, and with the finest emery put the last grain on the glass previous to polishing, using a strong magnifier to look for scratches ; being satisfied the lens has a fine equal grain all over and free from scratches, wash all clean and prepare the polisher. Procure $\frac{1}{4}$ lb. of the finest putty powder, warm the brass tool and smear the inside of it with pitch ; lay a piece of fine cloth over the

lens and turn up the tool with the pitch upon it ; the cloth will stick to it, and when cold smear the cloth with the putty powder and water, rubbing the lens until on looking with the eyeglass no trace of the effects of the fine emery is seen. Warm the lens before a fire, slide it off the wooden holder, wash the pitch from the lens with turpentine, spirits of wine, or other solvent, and you will have ground and polished a plane convex lens of 10 inches focus, it being a rule in optics that a lens ground on one side only will have its focus at twice the radius ; but ground on both sides, will have its focus at the radial point. You must now turn the other side, taking care of the feather edge as you approach it, by not going so far with the coarse emery. When the second side is finished, you will have a crown lens of 5 inches focus. To make the terrestrial telescope an achromatic one, add a concave lens of flint glass to it.

We will suppose the crown lens is finished ; but as its form is thick in the centre and thin at the edge, it will be similar to a circular prism, and would show all objects with the chromatic colours ; another lens must therefore be ground that is thick at the edge and thin in the centre, to counteract the dispersive power of the convex lens, and as flint glass has in general twice the specific gravity of crown, and consequently has twice the dispersive power, it will of course do the same amount of work with one-half the angle of the crown lens, as in fig. 3, and so reunite the coloured rays and form again white light. Accordingly grind one from the bottom of a flint-glass tumbler. Grind it on a flat stone to the proper thickness, and also get it to the diameter by taking a strip of sheet iron an inch wide and bend it so as to form a collar ; by putting emery and water betwixt the collar and the glass, by pinching the collar with the fingers while the glass revolves on the nose of a wooden chuck, it will be reduced in a few minutes. After it is the proper diameter and thickness, commence rubbing it on the convex tool and finish it in the same manner as before ; you will now have a concave side finished which will fit the convex lens ; take it off the holder and turn the last side up, and now learn that it is a very difficult thing to grind and polish a surface truly flat, so that you had better grind the last side concave upon a tool of a large radius, say 30 inches. The two glasses must then be cleaned and made warm gradually before a fire ; a drop or two of Canada balsam being let fall into the concave

lens, drop the convex one on it, press the air bubbles out, and when the balsam sets you will have a small achromatic lens. The streaks or striæ in the bottoms of tumblers are not of so much importance in a terrestrial telescope. Some of the best photographic lenses have air bubbles, and some when accidentally cracked work quite as well as before. In astronomical telescopes the glass must be of the purest kind.

Now take your compound lens and try its focus by the sun, and make the tube 3 or 4 inches longer, so as to support the magnifying tube called the eye-piece. The object lens will form an image of anything within the tube, say the clock-dial of a distant church—the tube called the eye-piece merely magnifies this image, and a

variety of eye-pieces may be used for the same object glass, according as a high or a low power is required; in short, a telescope

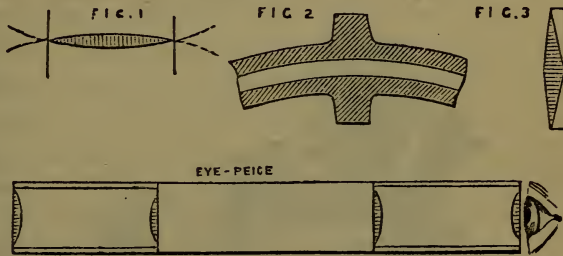

may be compared to a camera obscura, with a microscope attached, to enlarge the image formed by the object glass.

Now then about the eye-piece. The subjoined formula may be taken, because the lenses for it are all planos, so that you will only have to grind one side of them, if a piece of plate glass be used. Focus of front lens $1\frac{3}{8}$ ths, ditto of second lens $1\frac{3}{8}$ ths, ditto of third lens $1\frac{3}{8}$ ths, ditto of lens next the eye $1\frac{1}{8}$ th. The first and second lenses may be a little under $\frac{1}{2}$ inch diameter; the third or field lens may be a little more than $\frac{1}{2}$ inch diameter; and the lens next the eye may be about $\frac{3}{8}$ ths diameter.

Make two short tubes $1\frac{3}{4}$ inches long (they are called cells), and fix your lenses to each end of the two tubes or cells, then take a tube called the eye-piece $6\frac{1}{8}$ inches long, and slide the two cells into each end of this tube; you will then have an eye-piece which must slide into the larger tube to focus on the image formed by the object glass.

In the following machine for grinding and polishing speculum, A is the base, *f* is the worm-shaft which drives the worm-wheel

b, and this is bolted to a spur-wheel *c*, both of ninety. They turn on a stud *g*, and are made with a circular flange near their periphery, the lower surface of which bears upon a trued part A, and the upper gives a firm support to the speculum and its cistern (not shown in the engraving). The wheel *c* drives another of fifty-two not seen, but attached to the lower surface of the cam *d*; in the groove of this is engaged a pin, fixed in the lower surface of the cam lever *e*, which is thus made to vibrate as the cam revolves. The lever has a series of holes, to any of which can be attached one end of a link, whose other end is connected with the upper or sliding-plate B, which thus by the rotation of the cam is made to vibrate to and fro according to any required law, the actual law being that of uniform motion. The plate B carries a strong spindle *h*, on which

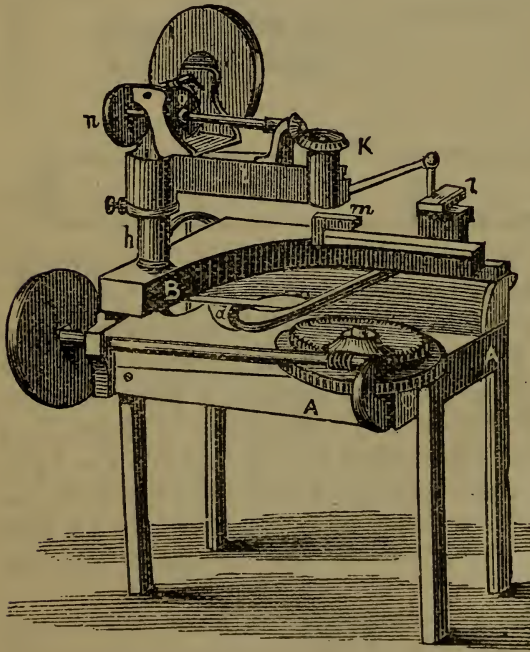

vibrates the arm *i*. This arm can be at pleasure either held in position by the connecting-link *k*, or made to vibrate by the revolution of the variable crank *l*, which is driven by a shaft at the back of the slide-plate B. The arm carries a variable crank *m*, which can be driven either quickly by the shaft and pulley *n*, or slowly by the worm-wheel *o*. The pin of *m* drives the polisher. If it be required to give Lord

Rosse's action, the crank *m* being fixed, and its pin set central, the crank *l* is set in motion; this gives the primary stroke, and the reciprocation of the slide plate B gives that of the eccentric. If the worm-wheel *o* be made to act, at the same time a light lever attached to *m* will carry round with a slow motion the polisher by a stud projecting at its circumference. If it be wished to have

Mr Lassell's motion the crank *l* is stopped, and it is fixed in such a position that the pin of *m* shall be at the required distance (equal radius of S) from the centre of the speculum, the arm *i* being held firm by the link; the pin of *m* is next set to the distance which equals radius of G, and it is driven by *n*. In this case, however, there is no provision to secure the rotation of the polisher. The eccentricity can also be given by means of B, and as it can be made to vibrate slowly on each side of this to any required extent, the effect of Mr Lassell's last improvement is given to perfection. Mr Grubb decidedly prefers the Rossean action for grinding, but thinks the other less likely to fail in the polishing with unpractised hands, and uses it himself. He begins with a large eccentricity, and gradually diminishes it, which can be done without stopping the machine. His polisher is made of wood with peculiar care. It is formed by six layers of mahogany, each $5\text{-}16$ ths of an inch thick, and not continuous, but built up of pieces 3 in. square; these are only glued where they cross, being, at least in the interior, not in close contact at their edges, and the direction of their grain is varied as much as possible. The disc, when turned true, is plugged at the edges, varnished, and coated with tinfoil at the edge and back. It is the same diameter as the speculum. He uses pitch alone, rolls it in the same manner as Lord Rosse, cuts it into squares of $\frac{3}{4}$ in., and attaches them to the surface, warming it by a spirit lamp. The machine measures about 3 ft. every way, and can work a 2 ft. speculum.

Power of Lenses.—The magnifying power of lenses is determined by the focal length and the density of the glass of which they are composed. In the case of a telescope, the power may be calculated approximately by the following rule:—If the focus of the eye-piece be 1 in., the number of inches in the focal length of the object-glass will give the magnifying power; if the eye-piece be $\frac{1}{2}$ -in. focus, the power will be twice as great as with the 1-in., and so on in proportion.

The following is a more full explanation of the mode of ascertaining the power of a telescope. First focus it accurately upon a distant object. If now you turn the object-glass up to the sky, and remove your eye to some distance from the eye end, you will perceive a circular spot of light upon the eyeglass. This is an image of the object-glass, diminished in the exact

ratio of the magnifying power of the instrument. If then you will measure the precise diameter of this image upon a finely-divided scale (assisting your vision, if necessary, by means of a magnifying-glass), and will then ascertain the diameter of your object-glass by the aid of the same scale; the division of the latter sum by the former will give the magnifying power of the instrument. Thus, supposing that the aperture of your object-glass is 2 in., and the little circle of light in the eye-piece is $\cdot 08$ in. in diameter, the telescope will magnify exactly 25 times; or, assuming that you have a $1\frac{1}{2}$ -in. object-glass, and that the projected image on the eye-piece measures $\cdot 08$ in. in diameter, your instrument would then magnify 18.75 or about 19 times linear. In obtaining the magnifying power of a single lens, we proceed upon the assumption that the distance of distinct vision is 10 in. If now we find the focal length of the lens, and divide 10 in. by it, we shall get the magnifying power. For example, a lens of 1-in. focus magnifies 10 times, one of $\frac{1}{2}$ -in. focus 20 times, one of $\frac{1}{4}$ -in. 40 times, and so on. The focal length of a lens (when not very short) may be obtained with considerable accuracy by projecting an image of the sun upon a card, by means of the lens whose focal length is to be measured, and when such image is accurately defined, measuring the distance between the lens and the card. This may be conveniently accomplished by mounting the card at the end of, and at right angles to the length of, a graduated scale, and sliding the lens along the scale with its diameter parallel to that of the card. In the case, however, of a lens of very short focus, this method becomes impracticable; and we may then have recourse to the admirable mode invented by that excellent astronomer, the Rev. T. W. Webb, which we cannot do better than describe in his words. "Three pieces of cork are perforated by a knitting-needle, so as to slide along it. To the centre one is attached, in a vertical position, and with its axis parallel to the knitting-needle, the lens to be measured; in each of the others is inserted a piece of a sewing-needle with the point uppermost, and having its length so regulated that a line joining these points would pass, as nearly as may be, through the centre of the lens. The cork discs carrying these needles are then moved backwards and forwards, till the inverted image of the one needle's point, formed by rays passing through the lens, is seen coincident and equally dis-

tinct with the other needle's point, when both are viewed at once, through a tolerably strong magnifier applied to the eye, and directed towards the lens. Then if the needle-points are sensibly equidistant on each side of the lens, a condition which can be quite sufficiently attained in the course of a few trials, it is evident that they occupy the conjugate foci, and the distance between them being carefully measured with compasses will be, as a very simple proposition in optics will show, *four times the amount of the focal length of the lens for parallel rays.*"

Screw-Propeller.—The primary consideration of the applicability of a screw-propeller to the work it has to do is its "pitch," that is, the length in which the screw-whirl makes a complete turn round its central axis, and this "pitch" is either "finer" or "coarser," as the length of the axis AB is shorter or longer; or in other words, as the turns of the screw are closer together or further apart. It is evident that if there be no "slip," that is, if the screw retains full hold upon the water, as a carpenter's screw does upon a board—that in every revolution of the screw-propeller a distance of the length of the axis of the full turn of the screw will have been accomplished by the vessel. If thus the "pitch" of the screw be 40 ft., that is, if from A to B be 40 ft., then every full revolution of the screw will, if there be no "slip," advance the vessel 40 ft.

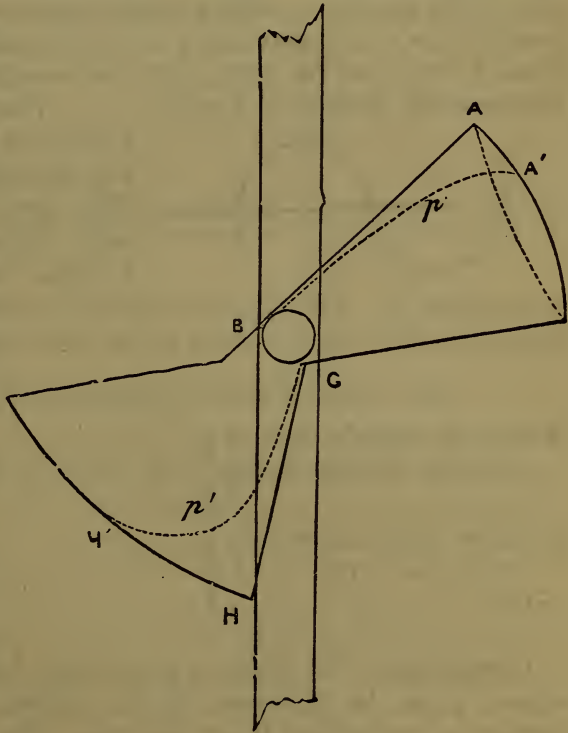

through the water. From repeated experiments it has been determined that the best form which can be given to a screw is that of two halves of a spiral feather, placed on opposite sides of the axle of the screw in reverse positions ; these, while they occupy only half the space

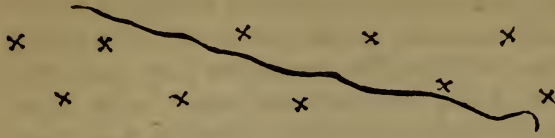

in length which they would otherwise require, are found, with equal surface, more efficient than the continuous spiral formerly in use. The rectilinear edges AB and GH of the ordinary screws are highly disadvantageous, on account of the shake of the screw caused by the sudden and violent reactions of the disturbed water in that place against the blades of the screw as they enter and emerge from thence—since the whole of an edge enters and leaves at once the water on each side of the aperture ; within which aperture the water is comparatively in a quiescent state ; but if the leading edges of a screw blade were curved as $A\phi B$, $G\phi H$, they would slide obliquely and continuously through the water. . . . The curved edges have,

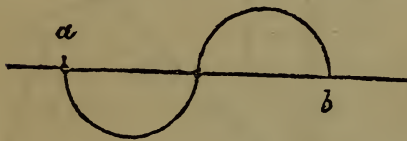

beside, the advantage of throwing off any floating materials that may come in contact with them” (Sir Howard Douglas on “Naval Warfare

with Steam”). The pitch of screws vary with the ratio of the circle described by the screw to the midships section.

For 2-bladed screws (Molesworth's formulæ).

Ratio of screw's disc to midships section being	}	6	5	4½	4	3½	3	2½	2
1 to									
Ratio of pitch to the diameter of screw is 1 to	}	.8	1.02	1.11	1.21	1.27	1.31	1.4	1.47

Gyroscope.—To make a gyroscope, get a brassing AAA, about 5 in. in diameter, ½ in. broad, and ⅛ in. thick, having a projection B at one part. On the flat surface of the ring, near to B, must be a small lump C, also another just opposite D. These must be screwed on by two small screws

each, and are for the purpose of holding the spindle EE, which must turn freely on these centres. At

FIG. 1.

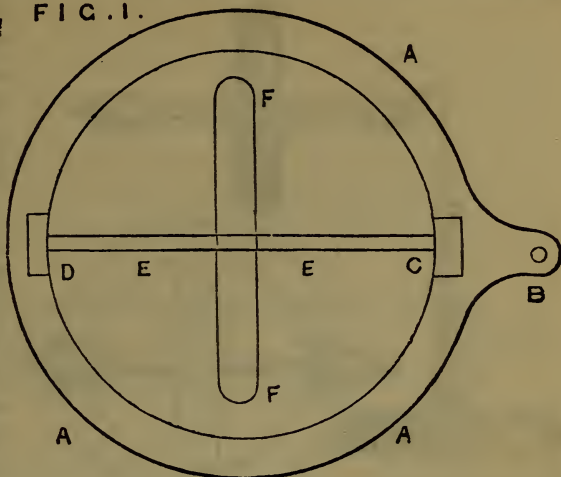

the middle of this spindle must be fixed the disc FF, which should be about two or three times as heavy as the ring. A hole must be drilled through this spindle at some convenient part for the string. The method of using is this :—The

hole in the spindle must be threaded with a piece of string, and the disc turn round, winding the string up the same as is done with a humming-top. The string is then drawn sharply out, and the disc made to spin rapidly round. If the instrument is then supported by a loop of string, or on a point

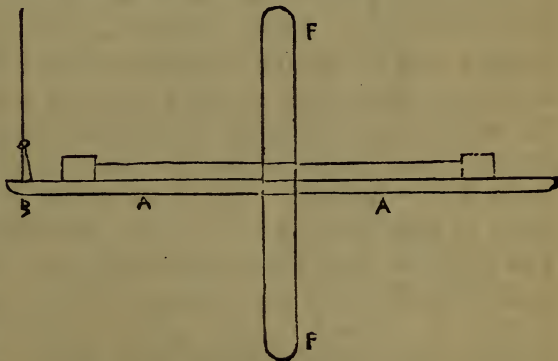

at B, it will (instead of falling to the ground, as might be supposed) remain in a horizontal position, moving round B as a centre. (See engraving.) The ring AAA should be placed horizontally.

Another method, identical in principle, but differing slightly in detail, is as follows :—

The wheel is brass, turned to the shape shown in sketch ; the axis of the wheel is steel. The wheel is first bored for the reception of spindle ; then the spindle is driven in after being cut to its proper length, and drilled with very fine centres ; it is then turned on its own centres perfectly true. A lathe with two dead centres is the best for turning it. After it is turned, the ends of the spindle are properly hardened. A small hole

is inserted in one end of spindle for reception of twine. The

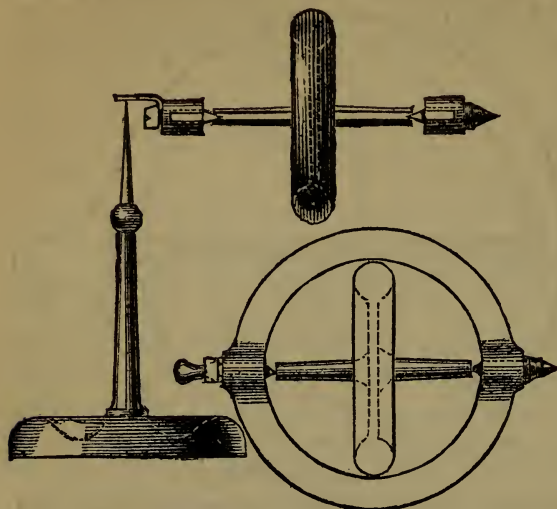

way to harden the ends of the spindle is this:—Get a plate of iron about $\frac{3}{8}$ in. thick, bore a hole in it just large enough to admit the end of the spindle, then place it on the fire (a small slow fire). Fill the upper recess of wheel with cold water, to keep the brass cold.

The ring is made of brass, is about $\frac{1}{8}$ in. thick and $\frac{1}{2}$ in. broad, with two bosses in the direction of the centre line. These bosses are bored and tapped about 3-16ths or $\frac{1}{4}$ in. for the reception of steel screws. The ring is bored out, and filled up until the ring is equally balanced; if the ring is not balanced, it will not hang horizontally as it rotates round the point, but the heavy side will hang down, and cause it to “waver.” One steel screw is ground to a sharp point at both ends, with a square shoulder to screw it in with. The point of these screws are hardened, the other screw has a square head with a sharp centre drilled in it. A small steel bracket is secured by this screw, as shown in sketch. This bracket has a sharp centre in it made with a sharp centre punch to rest on the point of upright spindle; this bracket is also hardened. The upright spindle is made of steel, screwed into a base of lead, as shown in sketch. The spindle is turned and ground to a very sharp point, then properly hardened. The wheel will not only revolve horizontally round the point, but will revolve when placed perpendicular by placing the centre in head of screw (as shown) on the point of spindle; it will also spin on the point of the other screw if placed on a plate or any smooth surface. After the points of spindle or axis of wheel are hardened, the points of screws being soft, the wheel is spun round a few times to grind the centres to fit each other. After that the points of screws are hardened.

Telescope, to Make.—To make a Galilean telescope the following articles are required:—A double-convex lens of 5-ft. focus and 2-in. diameter; a double-concave of 1-in. focus and about $\frac{1}{2}$ -in. diameter; a large tube of tin-plate, zinc, or cardboard, 4-ft. 8 in. long, and 3 in. diameter; a cylinder of wood, turned to fit tightly in one end of the large tube, and having a central hole of about 1 in. diameter bored through it; and a small tube for the eyeglass 6 in. or 8 in. long, and of just sufficient diameter to slide into the central hole of the cylinder. The section will explain the use of

these articles. A is the large tube; B, the object-glass; C, the wooden cylinder; D, the eye-tube; and E, the eyeglass.

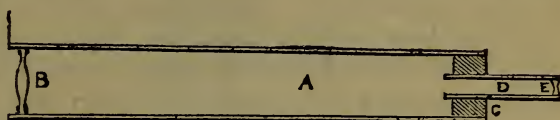

The object-glass and eyeglass must be at a distance from each other equal to the difference of their focal lengths, and the power will be equal to the number of times the focal length of the eyeglass is contained in that of the object-glass. In the present case this is 60.

Tin-plate is the best and cheapest material for the tube, but in reality it matters little of what it is made, so that it be straight and not too heavy. Its interior should be coated with a mixture of lampblack and turpentine. A diameter of three inches is best, in order to decrease the liability of flexure which very narrow tubes possess, and also to give more facility in mounting the object-glass.

In purchasing this article, it is much the better plan to buy one from the optician already centred; but if such cannot be obtained, one should be selected the edges of which possess a uniform thickness. In such a one the optic axis will not be very far from the actual centre. In mounting it, glue it between two circular rings of cardboard, whose outer diameters just fit the large tube, and with a central circle cut out of each $1\frac{1}{2}$ in. in diameter. The lens must be fastened between these, so that its centre will coincide as nearly as possible with the centres of the cardboard circles. It should be placed an inch or two within the tube, as it is then better defended from injury than when at the very extremity.

A ring of iron wire soldered within the tube will do to rest

the mounted lens upon, and another ring of wire pushed down upon it will hold it firmly in its place. These rings are shown in the section by the four black dots, two on each side the cardboard mounts of the object-glass. The eyeglass may be fitted in a similar manner. The length of the wooden cylinder should not be less than 2 in.

In making the Galilean, or any other telescope, the one great thing to be attended to is to keep the centres of all the lenses coincident with the axis of the tube, and their planes at right angles to it. Inattention to this is certain to injure the performance of the telescope, however good its glasses may be. Most of the failures in amateur-made telescopes that have come under my eye have arisen from this cause. It will be seen that a first requisite to success on this point is to make the tube perfectly straight and rigid, and its section perfectly circular. The wooden cylinder should be turned perfectly true, the hole drilled through it perfectly central, and not the slightest lateral play allowed to the small eye-tube. Though in none of these particulars is absolute perfection attainable, yet any one making a telescope should never forget that the nearer he can approach it, the more satisfactory will his instrument be.

There is one point to which the attention of all beginning to handle lenses should be directed, and that is, to avoid wiping and rubbing as much as possible. Remove any dirt that may fall on the glass by blowing it away, and remember that the definition of a telescope is much less injured by a deposit of dust on the object-glass than by the numberless small scratches which much wiping invariably causes.

The cost of this telescope is as follows:—Object-glass, 2s. ; eye-glass, 1s. ; tube (if home-made) of tin-plate, 1s. 6d. ; wooden cylinder, lampblack and turpentine, say 6d. more ; total, 5s. It will show well Jupiter's moons, and more conspicuous belts, Saturn's ring, and one or two of his moons on favourable nights, the phases of Venus and Mars, the hills and valleys of the lunar surface, and the solar spots splendidly, together with many nebulae and double stars.

A stand for our telescope must not be forgotten. A poor telescope on a good stand is greatly superior to a good telescope on a poor stand.

Telescope Stand.—An excellent stand was made a few years ago, on the following model:—

It is made of deal; the advantages are steadiness, the work being thrown into triangles, the steadying cords and weights checking all vibration. The spindle may be placed and adjusted to the position of a polar axis, and by fixing pins on permanent blocks in the ground, with brass sockets on the bottom of the legs, the stand may be always placed in the same position. There may be various changes in the position of the cords and weights. The first use made of them was to steady the end of the telescope put through a window by cords and weights in the position figured, where CCC are cords, and T telescope.

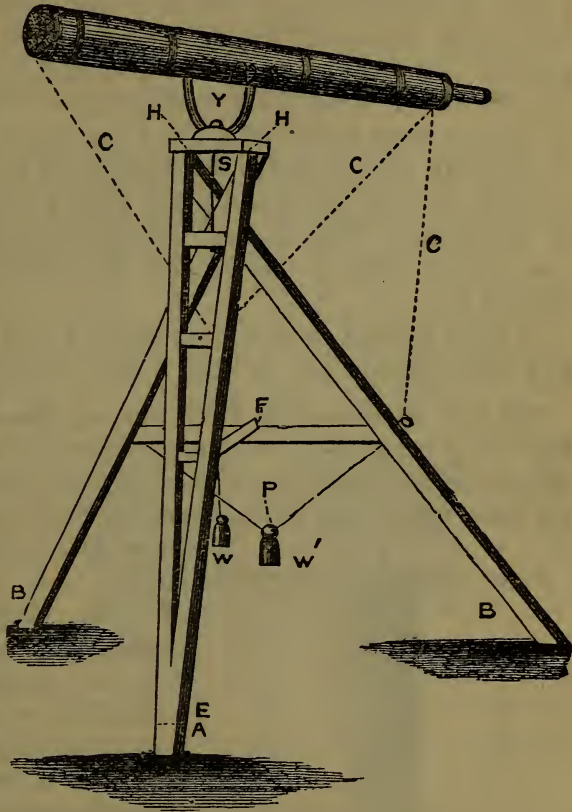

Made in two movable parts, feet of one A, of the other BB; hinged together at HH; E, screw-bolt; F, cross-piece from fore to hind part; CCC, steadying cords, with weights W and W¹, the latter running on pulley P; SS, spindle turning in brass bearings; Y, iron supporting the sides of telescope on two screw-pins.

The Y spindlehead suspending the sides of the telescope is much steadier than a swivel-joint

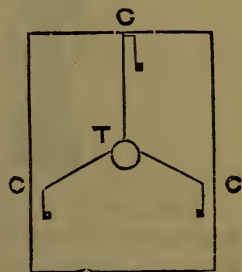

under the telescope tube. Height to pivots of telescope about 6 ft.

A good "Dead-Black" for Telescopes, Cameras, &c., is somewhat troublesome to make. Take some ordinary French polish, or dissolve some shellac in methylated spirit, and add lampblack until the happy medium is attained, that when applied to a piece of warm brass, it shall dry a dead-black. If it dries with a dead-black surface which rubs off, more polish or shellac must be added; if it dries bright, more lampblack.

Another plan is to put the brass-work into dilute nitric acid to take off any oxide, and put it into a solution of bichloride of platinum; when it has changed colour, brush the work sharply up with a brush and dry blacklead, after which lacquer it.

A third method is to take lampblack and mix it with water, and just sufficient size to keep it from rubbing off.

To Cut Microscopic Sections of Wood.—The following engraving is half-full size of a machine for cutting thin sections of objects for microscopic examination, which has been in use for some years, and which is one of the cheapest, simplest, and

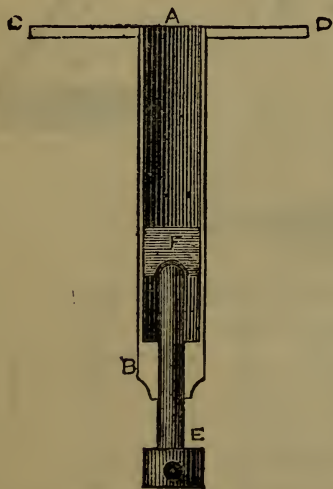

most effectual that could be devised. AB represents a piece of $\frac{1}{2}$ -in. brass tubing, with a flange CD, of about $2\frac{1}{4}$ in. in diameter, at the end A, and with a female screw tapped at the end B to receive the capstan-headed screw E; F is a brass plug or piston, which is driven up the tube in a perfectly obvious way by the screw E. This screw has 30 threads to the inch. A razor ground flat on one side, to slide accurately over the upper surface of the flange CD (which must itself be quite true), completes the apparatus.

The mode of using it is simply this:—The wood, or other substance of which a section is to be made, is to be driven down the tube at A. The screw is then turned until the object to be cut projects slightly above the mouth of the tube, and the

razor is slidden across it, taking off a slice of the material, and reducing it to a level with the surface of the flange. By turning the screw again to a small extent, and again sliding the razor (which should now be wetted) across the flange, it is perfectly clear that we may remove a slice of wood of any tenuity we please, its thickness being regulated by the extent to which the screw is turned. The sections thus made may be conveniently washed off into a cup of water, to be taken out as required.

Several more or less elaborate pieces of mechanism may be purchased at the optician's, at prices varying from 15s. to £4; but none will do their work more effectually than that described, which ought not to cost more than six or seven shillings.

Another Cutting-Machine.—B, a block of wood with a hole, into which is fitted C, a brass tube; D, a brass plug or lift accurately fitted, and having two studs S to work in corresponding slots in C; E, an iron pin without head fixed with D—pitch 25 threads; H, a brass nut, the top fitted to C, through it works E. The nut has two collars or flanges, M and N, and between is O, a split collar, which is screwed on to the box B. This collar keeps the nut in place, and yet allows it to be turned; XX, two studs to turn the nut H; Z, a bending screw to keep object in place; T, a bench clamp; A, brass plate on which to cut.

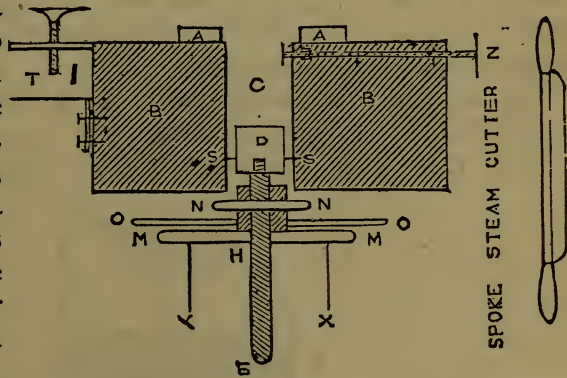

The great advantage in this construction is the pin and plug moving (up and down) vertically without turning or twisting in the tube or cylinder more than the fractional ease of the slots in which the studs work. The plug being fitted nicely to the cylinder, and the pin fixed into it, and the nut working nicely in the collar, gives a firmness not to be obtained in machines in which the pin turns. The pitch of the screw is 25, therefore a quarter turn of the nut gives the 100th part, and an eighth turn the 200th part of an inch.

The cutter is a spokeshave with the ends turned straight and fitted into handles. The hollow, or under side, on the plate is used, the face of the plate being very flat and straight. The inventor of this machine prefers the under side of a cutter hollow, not flat, as recommended by many. There is less adhesive resistance, and no slipping, as with the perfectly flat surface.

Hints on the Microscope.—A mechanical stage is a *sine qua non*, and plenty of room beneath it for the illuminating apparatus. This stage should not be thicker than the $\frac{1}{8}$ th of an inch, a mere plate with a wide hole, say 2 in. square, the milled hands and tangent screws being all placed behind the frame, easy to get at, and out of the way of the objects.

This form does not admit of a circular motion, but we have not yet learnt the real value of such a motion, while the advantages of a thin stage are unspeakable.

A Coddington lens, or an eye-piece on Kelner's principle, makes a good condenser, and only cone eye-pieces are worth using; if you desire higher magnification, either get a higher power or lengthen your tubes.

An economic condenser made by an amateur microscopist is shown in the following sketches:—

Fig. 1.—A, spot-lens, about $\frac{1}{2}$ -in. focus; B, achromatic spot-lens, about $1\frac{1}{4}$ -

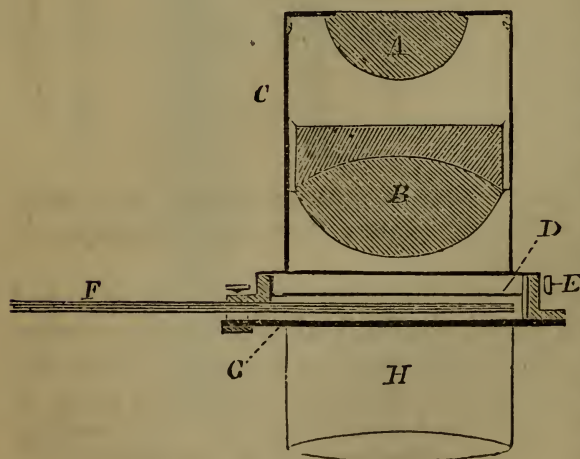

Fig. 1.

in. focus, placed at about the same distance as in a Kelner eye-piece, in a tube C, screwed in a flat ring of metal D, which is supported on a flat plate G, secured by a holdfast E, allowing room between for a diaphragm F, to revolve freely on its axis, which is done by a screw passing through a holdfast into the plate G; H is a tube $\frac{3}{4}$ -in. long for carrying polariscope.

Fig. 2.—DIAPHRAGM.—A, for direct light ; B, for difficult test-objects ; C, dark-ground illuminator ; D, small aperture, with shutter E, having a small hole in it. The features presented by this condenser are that it is applicable for both high and low powers, can be used by merely sliding it into a tube under the stage, and never need be removed except for cleaning.

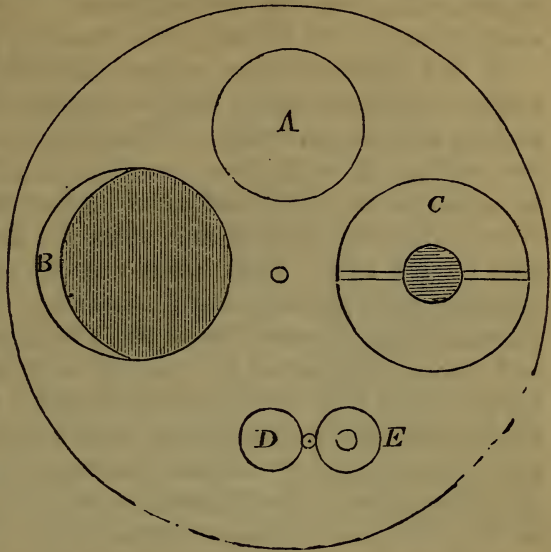

Fig. 2.

For a micrometer, the following plan, which any one can adopt, and requires no apparatus, is quite effective.

Find the exact size of your field by looking at a footrule laid beside your stage with the one eye, while the other is applied to the pipe ; say it gives 1 ft. Now put the rule on the stage, and see how many divisions of an inch fill the field ; suppose it is $\frac{1}{8}$ th in. in this assumed case, this object-glass, with the same length of tube, will magnify 96 linear, therefore all objects viewed will be increased to that extent.

Your instrument must be steady, the fine adjustment very fine, the spring very light, and the tube into which the object-glass is screwed, and which the adjustment moves, very true, and also very easy to lift, so that a coarse hand may neither damage the instrument nor object, and each turn ought to raise or depress it 1-100th of an inch, and so become a micrometer to measure depth.

For a camera lucida, get two bits of neutral-tinted glass, and place them at an angle of 45° before the eye-lens. A little practice will enable you thus to use the binoculator, and the ease to the eyes is immense.

For polariscope, use a short white Nicol's prism, set so as to turn in a tube, and to which tube you can screw the object-glass.

A number of large squares (16 or 20, $\frac{7}{8}$ size) such as we cover objects with, form the best analyser. The polariscope is, however, except in the hands of the chemist, pretty much a toy.

It is a great mistake to have slides in any numbers; have many compressoriums, lots of bottles and small tanks, and eschew diatomacæ valves. Wherever you go, carry a nail or two and an old lucifer-box, a walking-stick and a bit of string; tie a vial to the stick, and dip from top, bottom, and middle of every permanent water-hole; when you find a small insect, put him in the box. Your walks will be all pleasure, and your evenings both pleasure and instruction. Make for yourself all your apparatus; never mind the polishing, but make all good and true as to the brass, &c.; put all the polish on the glasses, and begin with a 2-in. and a $\frac{1}{2}$ -in.; the glass of moderate angle is much preferable to the ground 1708 lenses. These latter cannot be illuminated by annular condensers, and thus the prettiest and pleasantest way of viewing an object is lost. The "celia" of the *Feloscalaria ornata*, for instance.

Keep in your small tanks a few roots of *Zitella*, and *Valisneria*: both are good for the infusoria, and charming objects in themselves. From the air, ground, river, pond, or sea, get your objects; remember that slides once seen become tiresome.

Mathematical Instruments, &c. — All polished steel instruments are best kept from rust by enclosure in wool. The high conducting power of metal causes easy condensation of moisture (the cause of rust); wool is a good non-conductor of heat or cold.

Weather-Glass.—Various experimental barometers have from time to time been constructed, all with the view of combining economy with simplicity in a greater degree than is obtained in the ordinary weather-glasses of commerce.

A simple barometer may be made as follows:—

A wide-mouthed glass bottle is filled with ordinary drinking water up to the point indicated by the letter A; into this is dipped an inverted clean oil-flask, the extremity of the neck being allowed to dip just below the surface of the water.

The flask should be inverted quite empty during wet weather, and as long as the atmosphere remains in a stormy condition no change in the water takes place; but immediately the

weather becomes finer, the water will rise in the neck of the inverted oil-flask, and if a continuance of fine weather be probable, will rise to the point indicated by letter B.

This simple contrivance gives sure and early warning of the approach of rain.

The principle upon which this little weather-glass acts is exactly similar to that of the ordinary mercury barometer, the rise and fall of the water due to the respective increase or decrease of atmospheric pressure.

By dividing the neck AB into six or eight divisions with the aid of a diamond or piece of flint, and then marking the lines so cut with ink, an approximate graduation of degrees of pressure may easily be obtained.

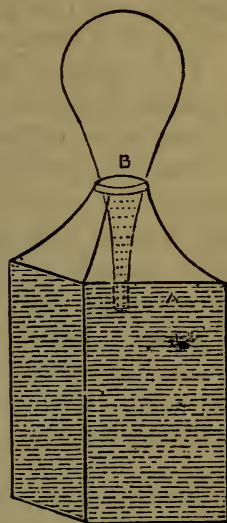

Cements and Glue.—Below are given a variety of cements to join anything from a millband to a knife-handle. The relative proportions are given in each case, and the directions for mixture and application must be strictly followed.

Cement to join Leather or India-Rubber.—To unite pieces of leather or india-rubber, use either of the following :—

One ounce of caoutchouc cut in thin slices, and placed in a tinned sheet-iron vessel, with six or seven ounces of sulphide of carbon ; the vessel is then to be placed in a water-tank, previously heated to about 86° Fahr. To prevent the solution from becoming thick and unmanageable, mix with a solution consisting of spirits of turpentine, in which half an ounce of caoutchouc in shreds has been dissolved over a slow fire, and then a quarter of an ounce of powdered resin, from an ounce and a half to two ounces of turpentinè being afterwards stirred in in small quantities.

Put a small quantity of virgin or native rubber, cut into shreds, into a wide-mouthed bottle, and pour over it benzine until the bottle is about three-quarters full. The rubber will, if often shaken, in a few days assume the consistency of honey, with a thick sediment at the bottom. If not thoroughly dissolved

more benzine must be added. The benzine must be of the best quality, and free from oil. Except when using, the bottle containing this cement must be kept well corked.

This cement dries in a very short time, and three coats applied in the usual manner will serve to unite anything either in leather or rubber.

Dissolve gutta-percha (1 oz.) in bisulphide of carbon (6 oz.). Apply the solution to both surfaces to be joined, allow to dry, which will take a few minutes; then place a hot iron near enough to just melt the gutta-percha on both surfaces; immediately press them well together, through rollers or under pressure. Leather fastened in this way does not need sewing. [A hose-pipe can only be joined in one way—the broken part cut out, the edges made square, a short piece of brass tube—fitting the hose tightly—inserted, and the two ends brought together over it, and bound tightly with copper wire].

Another excellent cement for millbands, &c., is—To 4 oz. of bisulphide of carbon add $\frac{1}{4}$ oz. india-rubber, and $\frac{1}{2}$ oz. gutta-percha, cut in shreds; place the whole in a half-pint bottle, well corked. It will dissolve without heat in about 12 hours, and be ready for use. The parts to be joined must be thinly coated with the solution, and allowed a few minutes to dry; then heat to melting, very quickly place together, and well hammer the air-bubbles out; the joint will be nearly solid, and has been proved perfect. The parts to be joined should be thinned down a little, so as to make an even splice; and the vessel containing the cement kept, tightly corked, in a cool place.

Cement for Tracings.—Take 1 oz. of isinglass glue, and 1 oz. of glue made of parchment, 2 drachms each of sugar-candy and gum tragacanth. Add 1 oz. of water, and boil together till mixed; when cold, form into little cakes. When to be applied, the glue may be wetted on a bit of sponge, and rubbed on the edges to be cemented; they will readily cohere on pressure.

Cement for Uniting Wood with Metals, Glass, Stone, &c.—Dissolve glue in boiling water, and make it of the same consistence as cabinetmaker's glue; then add, while stirring, a sufficient quantity of wood ashes to produce a varnish-like mixture. While hot, the surfaces to be united must be covered

or coated with this glue compound, and firmly pressed together. When cold, the joint will be strong, and the article ready for use.

Chemical Cement.—By melting together 2 lbs. of wax, 10 lbs. of resin, mixed with 4 oz. of plaster of Paris, and 2 lbs. of red ochre, an excellent cement can be made to serve for chemical and electrical apparatus.

Cement for Fixing Metal, Glass, Porcelain, &c.—The following is a simple and useful cement, having also the additional recommendation of cheapness. Make a tolerably strong solution of alum, stir into it plaster of Paris, until the liquid becomes of the consistency of cream, and use while in a liquid state.

This cement may be used for fastening brasses on lamps, &c.

Cement for Mother-of-Pearl, &c.—In 60 parts of water dissolve 4 parts of white glue and 2 parts of isinglass; then strain and evaporate until its volume is reduced to $\frac{1}{5}$ th; add $\frac{1}{15}$ th part of gum mastic dissolved in 1 part of alcohol, and 2 parts of zinc. When required for use, it requires to be warmed and shaken.

Glue that will Resist the Action of Water.—Boil 1 lb. of common glue in 2 quarts of skimmed milk.

Cement for Glass that will Resist Heat.—Equal parts of wheat, flour, glass, and chalk, finely powdered; to this mixture add half as much brick dust, and a little scraped lint in the white of eggs.

Cement for Aquaria.—Any of the following cements may be used to prevent leakage :—

1. 1 pint fine white sand, 1 pint litharge, $\frac{2}{3}$ ds of a gill of finely-powdered resin. Mix well, and keep in a corked bottle. When used, it requires to be mixed with boiled oil and driers, until of the consistency of putty. Do this mixing in quantities just sufficient for each piece of glass, as it dries very quickly.

2. Boiled oil, red and white lead, and litharge mixed together, and spread on a flannel, and placed on the joints.

3. 2 oz. benice turpentine, and solution of glue 1 lb. Boil these together, stirring the whole time until perfectly mixed.

This cement sets slowly, and the joints require to be kept together for two days.

4. Collins' cement, which is elastic, waterproof, and harmless, dries very quickly. When used, it should be cut up into small pieces about the size of a pea, and laid along the joint; a heated wire then being applied, the cement will run into a continuous strip along the joint.

Fire and Water-Proof Cements.—1. Take 2 parts of finely-sifted, unoxidised iron filings, mix with 1 part of perfectly dry and finely-powdered loam, and knead the mixture with strong vinegar until a perfectly homogeneous plastic mass is formed, when the cement is ready for use. It must be made as wanted, for it quickly hardens, and, once set, is never fit for use again.

2. A very excellent cement for smaller articles is made thus:—Soak 2 drachms of cut isinglass in 2 oz. of water for twenty-four hours; boil to 1 oz., add spirit of wine 1 oz., and strain through linen. Mix this, while hot, with a solution of 1 drachm of mastic, in 1 oz. of spirit of wine, and triturate with $\frac{1}{2}$ drachm of powdered gum ammoniac, till perfectly homogeneous.

Postage-Stamp Gum.—The gum used for stamps is what is called British gum, which is made from starch; its proper name is dextrine $C_{12}H_{10}O_{10}$; it is usually made by heating commercial starch suddenly to 320° ; anhydrous starch requires a temperature of 400° , and maintaining it at this heat for some time. The soluble product is dextrine or British gum, or the leïogomme of the French. Dextrine may be prepared on a large scale, of a much lighter colour, by the following process:—10 parts starch mixed with 3 of water, containing 1-150th of its weight of nitric acid, allowing the mixture to dry spontaneously, and then spreading it upon shelves to the depth of $1\frac{1}{2}$ in., and heating for an hour or hour and a half to above 240° .

Cement for Hot-Water Pipes.—Ram on to the flange a few strands of tarred rope, and fill up with iron boring cement, and ram in well.

Cement for Joining Steam Pipes.—Boiled linseed oil, litharge and whitelead, mixed up to a proper consistence,

and applied to each side of a piece of flannel, linen, or even pasteboard; and then placed between the pieces before they are brought home, as it is called, or joined. The cement is useful in joining broken stones, seams of water cisterns, &c.

Cement for Joining Steam Joints.—Sal ammoniac, 2 oz.; sublimed sulphur, 1 oz.; fine cast-iron turnings, 1 lb.; mix in a mortar, and keep dry. When to be used, mix with twenty times its quantity of clean iron turnings or filings, and triturate the whole in a mortar. Then wet with water until of a convenient consistence.

Red Putty for Steam Joints.—Stiff whitelead worked well in redlead powder.

Durable Cement.—Common clay well dried and powdered, then mixed with boiled linseed oil: it will last years. Mix ground whitelead with as much powdered redlead as will make it the consistency of putty. Mix equal weights of redlead and whitelead with boiled linseed oil to a proper consistence. These three cements mend stones well, however large.

Liquid Glue.—White glue, 16 oz.; dry whitelead, 4 oz.; soft water, 2 pints; alcohol, 4 oz.: stir together, and bottle while hot.

Varnishes.—In accordance with the nature of the solvent, varnishes are called spirit varnishes, turpentine or volatile oil varnishes, or fat oil varnishes. The first of these, whose solvent is sometimes ether or chloroform, but more commonly spirits of wine or wood spirit, dry off rapidly. These are very thin in coat when dry, and are best suited for paper, fans, or any very fine work requiring perfect transparency in the varnishes. Volatile oil varnishes, in which the solvents are spirits of turpentine, or coal naphtha, or the like, are those mostly employed by the oil painter. What is called "French varnishing," so much employed upon the wood of furniture, &c., consists in the application of alternate films of lac varnish and of linseed oil, with constant and sufficient friction to polish the compound film of spirito-fat oil varnish as soon as it has become thick enough to afford a glossy surface, the total thickness being exceedingly small. The method of varnishing employed by the carriage-builder for his finest work is the very

opposite of this. Over his last coat of paint he lays on coat after coat of copal or dammar varnish, until he has got a considerable thickness, often nearly $\frac{1}{10}$ th of an inch. When this to its full depth has got hard and perfectly vitreous in the warmth of the "varnishing-room," the whole surface is literally ground off with pumice-stone and water until a perfect form, as to contour, and a perfect superficies have been procured, when the glossy face of the varnish is then polished by putty powder, chamois skins, the hand, &c., just as a plate of looking-glass is polished.

Black Japan Varnish.—1. Boiled oil, 1 gallon; amber, 8 oz.; asphaltum, 3 oz.; oil of turpentine, as much as will reduce it to the thinness required.

2. Take pitch 50 lbs., dark gum amber 8 lbs., melt this, and add linseed oil 12 gallons. Boil this, and add 10 lbs. more gum amber, previously melted and boiled with 2 gallons of linseed oil, 7 lbs. each of litharge and redlead, and boil for two hours, or until a little of the mass can be rolled into pills; then withdraw the fire and thin the varnish as required for use with turpentine.

Varnish for Coloured Drawings.—Take 4 oz. of spirits of turpentine, and mix with 2 oz. of Canada balsam. Size the picture with a solution of isinglass in water. When this is dry, lay on the varnish with a camel's hair brush.

Varnish for Paintings.—Take mastic, 6 oz.; pure turpentine, $\frac{1}{2}$ oz.; camphor, 2 drachms; spirits of turpentine, 19 oz.; add first the camphor to the turpentine. The mixture is made in a water-bath; when the solution is effected, add the mastic and the spirits of turpentine near the end of the operation; filter through a cotton cloth.

Varnish for Glass.—Dissolve gum adragant in the white of eggs, beat up well, and lay it on the glass with a soft brush. The gum will take about twenty-four hours to dissolve.

Aniline Black Varnish.—The following is an approved Parisian varnish:—In a litre of alcohol, 12 grammes of aniline blue, 3 grammes of fuchsine, and 8 grammes of naphthaline yellow are dissolved. The whole is dissolved by agitation in less than twelve hours. One application renders an object

ebony black. The varnish can be filtered, and will never deposit afterwards.

Paper Varnish.—Below we give an excellent method of varnishing paper. First prepare the following varnish :—Pound very fine 4 oz. white sealing-wax, and after having sifted it through a lawn sieve, dissolve it in 2 oz. of alcohol. To dissolve, the ingredients must be put into a large bottle, and be shaken frequently during the space of forty-eight hours. Give your work two coats of a size made by boiling parchment cuttings in clear water, observing to do it quickly. When dry, apply the above varnish.

To Varnish Rarefied Air Balloons.—With regard to rarefied air machines, first soak the cloth in a solution of sal ammoniac and common size, using 1 lb. of each to every gallon of water; and when the cloth is quite dry, paint it over on the inside with some earthy colour, and strong size or glue; when this paint has dried perfectly, it will then be proper to cover it with oily varnish, which might dry before it could penetrate quite through the cloth. Simple drying linseed oil will answer the purpose as well as any, provided it be not very fluid.

Copal Varnish.—One of the best preparations for this varnish is the following :—Dissolve 1 oz. of camphor in 1 quart of alcohol, put it in a circular glass, and add 8 oz. of copal in small pieces; set it in a sand heat until it is dissolved, so regulated that the bubbles may be counted as they rise from the bottom, and continue the same heat until the solution is completed. Camphor acts more powerfully upon copal than any substance yet tried. If copal be finely powdered, and mixed with a small quantity of camphor, in a mortar, the whole soon becomes one tough, coherent mass.

Colourless Varnish with Copal.—To prepare this varnish, which can be applied to wood, metals, &c., the copal must be picked; each piece is broken, and a drop of rosemary oil poured on it. Those pieces which on contact with the oil become soft are the ones used. The pieces being selected, they are ground and passed through a sieve, being reduced to a fine powder. It is then placed in a glass, and a corresponding volume of rosemary oil poured over it; the mixture is then stirred for a few minutes until it is transformed into a thick

liquor. It is then left to rest for two hours, when a few drops of rectified alcohol is added and intimately mixed. Repeat the operation until the varnish is of a sufficient consistency; leave to rest for a few days, and decant and clear.

Varnish for Perforated Zinc.—1 dwt. of Canada balsam, thinned with spirits of turpentine until it is the consistency of milk. Then with a camel's hair flat brush sparingly varnish the perforated zinc. It does not require to be made warm, as articles do which have to be lacquered. It is this varnish which is usually made use of in fixing and covering the silvered parts of clock faces.

Wood Varnish to Resist Boiling Water.—Boil 3 lbs. of linseed oil in an untinned copper vessel. While boiling, suspend in the oil a bag containing 6 oz. of minium and 10 oz. litharge, both finely powdered, so that it will not touch the bottom of the vessel. When the oil has acquired a deep-brown colour, take out the bag and replace it by one containing a small piece of garlic. Melt 2 lbs. of yellow amber with 4 oz. of linseed oil, and throw into the vessel. Let the whole boil for about four and a half minutes, stirring well. After it has rested awhile, decant it; and when cold, pour it into stoppered bottles.

The wood having received the necessary colour, and having been properly polished, four coats of the above should be laid on with a fine sponge.

A method of coating wood with a varnish as hard as stone has been recently introduced: the ingredients are—40 parts of chalk, 40 of resin, 4 of linseed oil, to be melted together in an iron pot. 1 part of native oxide of copper, and 1 of sulphuric acid, are then to be added, after which the composition is ready for use. It is applied hot to the wood with a brush, in the same way as paint, and as before observed, becomes exceedingly hard on drying.

Varnish for Wood Patterns.—3 oz. of shellac, $1\frac{1}{2}$ oz. of resin, dissolved in a pint and a half of wood naphtha.

French Polish.—Any of the following receipts for French polish may be used:—1. Shellac, 1 lb.; naphtha, 2 lbs.; dragon's blood, 3 oz. 2. Shellac, 15 oz.; powdered mastic, $\frac{1}{2}$ oz.; sandarac, $\frac{1}{2}$ oz.; copal varnish, 5 oz.; methylated spirit, 2 lbs. 3. Shellac, 22 oz.; spirit of wine, 4 pints;

cod-liver oil, 2 oz. 4. Spirit of wine or naphtha, 1 pint ; gum, $\frac{1}{2}$ oz. ; shellac, 3 oz. ; dissolve with a gentle heat, and add 2 oz. of oil of sweet almonds. 5. Shellac, 1 oz. ; oxalic acid, 1 drachm ; naphtha, 4 oz. ; dissolve, and then add $\frac{1}{2}$ oz. of linseed oil. 6. $1\frac{1}{2}$ lb. shellac to 1 gallon spirit is a good proportion ; naphtha should be used only for coarse work. Methylated spirit is much preferable. No better polish is made than that with shellac alone, but in finishing, let the work, if small, and can be conveniently done, be *warmed*.

Varnish for Violins.—The varnish most used for violins is what is called a “fat” or oil varnish, made with amber. This is the most insoluble of gum resins, and, in its natural state, soluble only in chloroform. It contains an essential oil, oil of amber, and, until deprived of this by the process of melting, cannot be mixed or dissolved in spirits of turpentine. To form it into a varnish for violins, melt it very carefully in a sand-bath. A small iron saucepan half-filled with sand, in which a small thin cup is embedded to contain the amber, which should be coarsely powdered, will answer the purpose. If black smoke comes from the melting amber, the heat is too great—the amber is burning ; the right heat must be found by trial, it will be pretty well marked by the smoke or vapour being light-coloured or white. This indicates the evaporating oil of amber, which may be condensed if a retort and receiver is used. The vapour has a very powerful penetrating smell. A small quantity of amber will suffice, say 1 drachm, to make varnish for two or three violins. The amber, when sufficiently melted, will, when cool, be of a dark-brown colour, and in small brittle flakes. In this state put it into a small bottle with camphine (the best spirit of turpentine procurable), sufficient for solution (about four times the bulk of the prepared amber). Allow the mixture to remain a day or two, with occasional shaking ; then add best drying linseed oil, equal to $\frac{1}{6}$ th part of camphine. Size your violin, and get the grain of the wood thoroughly smooth, and apply the varnish with your finger on a warm sunny day, exposing the violin to the sun and air. A number of coats will be required, but a second should not be put on until the first is dry. Colouring-matter may be rubbed up with a palette knife, and some of the varnish, but there is great difficulty in laying the colour on smoothly.

Friction Polish.—A good polish for iron or steel rotating in the lathe is made of fine emery and olive, sperm, or neat's foot oil. Apply by lead or wood grinders, screwed together.

Soft Varnish.—For a good soft varnish, take linseed oil, 4 oz. ; and $\frac{1}{2}$ oz. each of gum benzoin and white wax. Boil to two-thirds.

Dryers.—Grind 1 lb. of white copperas, 1 lb. sugar of lead, and 2 lbs. whitelead with boiled linseed oil. Boiled or drying oil is linseed oil mixed with powdered litharge, and heated till it becomes thick. A "pale" drying oil is obtained by mixing with linseed oil sufficient dry sulphate of lead to form a milky liquid, and shaking it repeatedly for some days, letting it stand exposed to the light. When it has become quite clear, it may be poured off from the dregs. The sulphate of lead, when washed from the mucilage, may be again used for the same purpose.

Vehicle for Colour.—A good vehicle for colour is made by boiling shellac and borax in water. This solution may be used as a varnish, and, mixed with lampblack, forms an ink which will resist almost any acid.

Substitute for Brewer's Pitch.—Coat twice the inside of a barrel with a solution of $\frac{1}{2}$ lb. of rosin, 2 oz. of shellac, 2 lbs. of turpentine, and $\frac{1}{2}$ oz. of yellow wax in 1 quart of strong alcohol. After the complete drying of the second coat, give a last coat by applying a solution of 1 lb. of shellac in 1 quart of strong alcohol. This varnish will perfectly cover up the pores, and does not crack off or impart a foreign taste to the beer.

Lacquers.—Lacquers are used upon polished metals and wood, to impart the appearance of gold. As they are wanted of different depths and shades of colours, it is best to keep a concentrated solution of each colouring ingredient ready, so that it may at any time be added to produce any desired tint. Lacquer should always stand till it is quite firm before it is used.

1. *Deep Golden-coloured Lacquer.*—Seed lac, 3 oz. ; turmeric, 1 oz. ; dragon's blood, $\frac{1}{4}$ oz. ; alcohol, 1 pint. Digest for a week, frequently shaking. Decant and filter.

2. *Gold-coloured Lacquer.*—Ground turmeric, 1 lb. ; gam-

boge, $1\frac{1}{2}$ oz. ; gum sandarac, $3\frac{1}{2}$ lbs. ; shellac, $\frac{3}{4}$ lb. (all in powder); rectified spirits of wine, 2 gallons. Dissolve, strain, and add 1 pint of turpentine varnish.

3. *Red-coloured Lacquer*.—Spanish anatto, 3 lbs. ; dragon's blood, 1 lb. ; gum sandarac, $3\frac{1}{4}$ lbs. ; rectified spirits, 2 gallons ; turpentine varnish, 1 quart. Dissolve and mix as the last.

4. *Pale Brass-coloured Lacquer*.—Gamboge, cut small, 1 oz. ; cape aloes, ditto, 3 oz. ; pale shellac, 1 lb. ; rectified spirits, 2 gallons. Dissolve and mix as No. 2.

5. Seed lac, dragon's blood, anatto, and gamboge, of each $\frac{1}{4}$ lb. ; saffron, 1 oz. ; rectified spirits of wine, 10 pints. Dissolve and mix as No. 2.

Excellent lacquers are also made by the following receipts :—

1. *Gold Lacquer*.—Put into a clean 4-gallon tin 1 lb. ground turmeric, $1\frac{1}{2}$ oz. of powdered gamboge, $3\frac{1}{2}$ oz. of powdered gum sandarac, $\frac{3}{4}$ lb. of shellac, and 2 gallons of spirits of wine. After being agitated, dissolved, and strained, add 1 pint of turpentine varnish, well mixed.

2. *Red Lacquer*.—2 gallons of spirits of wine, 1 lb. of dragon's blood, 3 lbs. of Spanish anatto, $4\frac{1}{2}$ lbs. of gum sandarac, 2 pints of turpentine. Made as No. 1 lacquer.

3. *Pale Brass Lacquer*.—2 gallons of spirits of wine, 3 oz. of cape aloes, cut small, 1 lb. of fine pale shellac, 1 oz. of gamboge, cut small, no turpentine varnish. Made exactly as before.

Those who make lacquers frequently want some paler, and some darker, and sometimes inclining more to the particular tint of certain of the component ingredients. Therefore, if a 4-oz. vial of a strong solution of each ingredient be prepared, a lacquer of any tint can be procured at any time.

4. *Pale Tin Lacquer*.—Strongest alcohol, 4 oz. ; powdered turmeric, 2 drachms ; hay saffron, 1 scruple ; dragon's blood in powder, 2 scruples ; red saunders, $\frac{1}{2}$ scruple. Infuse this mixture in the cold for forty-eight hours, pour off the clear, and strain the rest ; then add powdered shellac, $\frac{1}{2}$ oz. ; sandarac, 1 drachm ; mastic, 1 drachm ; Canada balsam, 1 drachm. Dissolve this in the cold by frequent agitation, laying the bottle on its side, to present a greater surface to the alcohol. When dissolved, add 40 drops of spirits of turpentine.

5. *Deep Gold Lacquer*.—Strongest alcohol, 4 oz. ; Spanish anatto, 8 grains ; powdered turmeric, 2 drachms ; red saunders, 12 grains. Infuse and add shellac, &c., as to the

pale tin lacquer ; and when dissolved, add 30 drops of spirits of turpentine.

6. *Another Gold Lacquer.*—Seed lac, 6 oz. ; amber gum, guttæ, 2 oz. each ; extract of red sandal-wood in water, 24 grains ; dragon's blood, 60 grains ; oriental saffron, 36 grains ; pounded glass, 4 oz. ; pure alcohol, 36 oz. Grind the amber, the seed lac, gum guttæ, and dragon's blood on a piece of porphyry ; then mix them with the pounded glass, and add the alcohol, after forming with it an infusion of the saffron and an extract of the sandal-wood. Then grind all thoroughly. The metal articles destined to be covered by this varnish are heated, and such small articles as will admit of it, as small cases, watch-keys, &c., are immersed in packets. The tint of the varnish may be varied by modifying the doses of the colouring substances.

Before Lacquering Brass boil it in a solution of potash and soda, after which dip them in aquafortis, 3 parts water. Then wash them in two different waters, and rub them through sawdust. Then place on a gas stove. When warm, brush and put the lacquer on. After this operation is complete, the work is put back on the stove with a piece of brown paper over it. You can burnish or pick out, as you please.

Good Lacquer for Brass.—Seed lac, 6 oz. ; amber or copal, 2 oz. ; best alcohol, 4 gallons ; pulverised glass, 4 oz. ; dragon's blood, 40 grains ; extract of red sandal-wood, obtained by water, 30 grains.

Pale Lacquer for Tin Plate.—Best alcohol, 8 oz. ; turmeric, 4 drachms ; hay saffron, 2 scruples ; dragon's blood, 4 scruples ; red saunders, 1 scruple ; shellac, 1 oz. ; gum sandarac, 2 drachms ; gum mastic, 2 drachms ; Canada balsam, 2 drachms ; when dissolved, add spirits of turpentine, 80 drops.

Lacquer for Philosophical Instruments.—Alcohol, 80 oz. ; gum gutta, 3 oz. ; gum sandarac, 8 oz ; gum elemi, 8 oz. ; dragon's blood, 4 oz. ; seed lac, 4 oz. ; terra merita, 3 oz. ; saffron, 8 grains ; pulverised glass, 12 oz.

Solders and Soldering.—*Soft Solders.*—Tin and lead in equal parts. Easier of fusion still is tin, lead, and bismuth, in equal parts ; or 1 or 2 bismuth, 1 lead, and 1 tin, easier still. For soft soldering brass, tin-foil makes a fine

juncture, applied between the joints, care being taken to avoid too much heat. This is most excellent for fine brass-work. The tin-foil must be moistened in a strong solution of sal-ammoniac.

Plumber's Solder.—1 part bismuth, 5 parts lead, and 3 parts tin, forms a compound of great importance in the arts.

Brass Solder for Iron.—Melt the plates of brass between the pieces that are to be joined. When the work is very fine, the parts to be brazed should be covered with powdered borax, melted with water, so that it may mix with the brass powder which is added to it. Expose the piece to a clear fire in such a manner that it shall not touch the coals, and let it remain until the brass begins to run.

Silver Solder for Jewellers.—Take 20 dwt. of brass, 2 dwt. of copper, and 38 dwt. of fine silver, and melt them together.

Silver Solder for Plating.—Take $\frac{1}{2}$ oz. of pure silver and 5 pennyweights of brass, and melt them together.

Soldering Steel and Iron without heat.—Take $\frac{1}{4}$ oz of thirid acid, $\frac{1}{4}$ oz. of spelter, $\frac{1}{4}$ oz. of bismuth, and $\frac{1}{4}$ oz. of nitric acid. Put them all into the thirid acid; after well mixing, touch each part required to be soldered with the mixture, and put them together.

Solder for Tinware.—An excellent solder for tinware can be made from the lining of tea-chests.

Soldering for Leaden Gas-Pipes.—The blowpipe is not absolutely necessary, as the flame of the candle gives heat sufficient for the purpose by itself: prepare the joint in the usual way, then grease and sprinkle on a little powdered rosin. Now apply the flame of the candle, and touch with a strip of fine solder: as soon as the joint is sufficiently heated, the solder will flow easily. One candle will be sufficient for the smaller sizes of pipe; but by using two or more candles, joints may be made in this way up to 1 in. or $1\frac{1}{4}$ in. The solder must be fine, such as tinnens use; poured out in thin strips, and cut by the shears $\frac{1}{4}$ in. broad. In gas-pipes of what is called composition metal the blowpipe is absolutely necessary;

and, in fact, a blowpipe is most useful, and used in directing the flame round the pipe or to a required spot, and keeping up a continuous heat.

Blowpipe Joints are thus made:—Slightly taper one end of the pipe, and open the other end for it to fit into; clean the inside of the opened length, and the outside of the tapered end. Grease the same with common tallow, and sprinkle a little powdered rosin on it. Now with 10-in. blowpipe in the mouth, and rushes or spirit lamp held in the left hand, and a thin strip of soft solder in the right, gently heat the pipe before applying the solder. This solder should be composed of 3 parts fine tin, to 2 of lead. A small portion of bismuth will make it flow more easily.

Soldering, Hard.—One of the most common is that of silver soldering; it is composed of silver 2 parts, brass 1 part (common pins are the best). The silver is melted first, the brass then added and well melted together; it is then milled to the thickness of stout paper.

The work that requires to be soldered should be scraped clean and bound together with iron binding-wire.

A piece of lump borax is next rubbed with a little clean water on a piece of slate to the consistency of cream: the work should be covered with this by means of a small pencil, especially the parts to be soldered; the solder is then cut into very small pieces and laid across the joint with the pencil also; the work is then put on a piece of charcoal or bundle of iron wires, and gradually heated till the solder melts (by means of the blowpipe and gas). For rings, a piece of solder is passed between the join, and served as above (be careful of the stones, they must not be made red hot). *Gold* is generally soldered by gold of an inferior quality, as 22 carat soldered with 18 carat, 18 carat with 16 carat, &c. After soldering the binding-wire is removed, and the work boiled in nitric or sulphuric acid pickle (1 part acid, 10 parts water), and finished accordingly. It requires much practice to become master of the blowpipe.

Brass Melting.—The best method of melting brass is in a plumbago crucible. The best furnaces are built of fire-brick, open at the top, with an opening in the upper part of the back, connecting the furnace with the chimney, and another larger opening in the front, below the grate bars. A good

practical furnace may be made 12 in. square inside, 18 in. deep to grate, 12 in. below grate for cinders and air-passage, chimney opening $4\frac{1}{2}$ by 3, and 3 in. from top of furnace. This furnace is large enough for a No. 25 crucible, which will melt about 50 lbs. of brass.

To avoid Air-holes or Flaws in Brass Castings.—The theory of their formation is as follows :—Melted metal is more bulky than cold metal, and as the outside of castings cool first, it follows that the shrinking must take place within. The so-called air-holes are in reality not air-holes at all, but cavities formed by the shrinking of the metal. To avoid them, endeavour to equalise the patterns by coring, &c. If such is not to be done, run from the thickest part with a heavy runner. This process will tend to keep all in a fluid state until the outer portions have set, and so fill the cavities as they form.

Bending Brass Tubes.—Brass tubes are best joined by brazing up with melted brass. Tubes for musical instruments are bent by first filling them with lead, which, as soon as they have been brought to the required shape, is easily melted out again.

Brass Pickling or Brightening.—In order to remove the grease and dirt that may have accumulated during the process of fitting, the work should be placed in a red-hot muffle, or over an open fire; unless it be soft soldered, when of course it must be annealed before being fitted. If that be the case, or if the work have ornamental surfaces, it should be boiled in potash lye. When this is done, immerse it in a bath composed of diluted sulphuric or nitric acid in the proportions of 1 part acid to 3 of water. Allow the work to remain in this solution for from one to two hours, according to the strength of the acid; then rinse with water, and scour with sand, using a common scrubbing-brush; then wash well. To make the pickling-bath, dissolve 2 parts of zinc in 6 parts of nitric acid of 36° Baume, in a porcelain vessel, then add to the mixture 16 parts of nitric acid and 16 parts of sulphuric acid. Boil this liquid, and while boiling, plunge the work into it for about half a minute, until the nitrous vapour ceasing, the surface becomes uniform. Then rinse it well in clear water, to remove the acid. Should the work have

assumed a greyish-yellow tint, this may be removed by immersing the work for a short time in nitric acid. It should then be rinsed in a weak solution of potash, and covered with beech or boxwood sawdust, and afterwards rubbed until quite dry; after this it should be lacquered, to prevent the action of the atmosphere; and if a green tint be required, a little turmeric mixed with the lacquer will give it. By immersing the work in a solution of white arsenic in hydrochloric acid, a dark-greyish tint is obtained.

Coating Copper.—*To coat with Antimony.*—Dissolve 2 oz. of butter of antimony in 1 quart of spirits of wine, and add hydrochloric acid until the solution is clear. Into this solution put the object to be coated, previously well cleaned and polished. In the course of three-quarters of an hour a solid and brilliant covering of antimony is deposited. *Cast iron may be coated with copper* by placing it in an alkaline solution of chloride of copper, and then covered with antimony by the above process.

Coating Copper.—*The best way to coat copper with platinum* for a battery is to bend a sheet of zinc to enclose a porous cell, and connect the zinc without the cell in a suitable vessel with the copper in the cell, then fill both vessels with sulphuric acid 1, water 10, and drop a little solution of bichloride of platinum into the porous cell: it will be instantly thrown down on the copper as black powder.

German Silver, to polish.—An excellent powder for cleaning German silver and other bright metals can be made in the following manner. Take $\frac{1}{2}$ lb. of peroxide of iron (crocus). Put it into a wash-basin and pour on water, stirring with the hand. While the water is in slow motion, pour off the mixture, leaving the grit at the bottom; repeat this operation, and then put it at one side until the crocus has settled at the bottom. When it has done so, drain off the water, dry the powder, and keep in a bottle or canister.

If the work to be cleaned is very dirty, mix a little of the powder with oil; rub it on with the fingers, and polish in the usual manner. If only slightly tarnished, put a little of the powder on a piece of wash leather, and polish well, taking care that the leather be free from dust.

Hardness of Silver.—Goldsmiths often complain of the hardness of silver, which is sometimes very difficult to carve,

and presents a dead grey cut. These properties are generally attributed to the presence of a foreign metal ; but M. Mathey, assayer at Locla, has shown that in this silver there is neither tin, lead, nor any other injurious metal. He considers this property to be due solely to the high temperature at which silver is cast. By letting the crucible cool till a slight solid crust is formed on the surface of the fused metal, and casting at this moment, a soft silver with a brilliant cut is obtained.

Tarnished Plate, to clean.—Silver or plated objects may be cleaned, if tarnished, by dipping them, when they are small, into a moderately concentrated solution of cyanide of potassium, and when they are large, by brushing the solution over the tarnished portions, then washing well with distilled water, and afterwards drying with a linen cloth.

Silver and Galena, to separate.—If sulphuret of silver is melted with chloride of lead, a decomposition takes place, and sulphuret of lead and chloride of silver is formed. If, therefore, galena, which consists of sulphuret of lead with some sulphuret of silver, is melted together with chloride of lead, the silver is extracted from the galena, and lead takes its place. On this principle depends the new process, which is carried out as follows :—The galena is mixed with 1 per cent. chloride of lead and 10 per cent. common salt. If it contains much silver, a greater quantity of chloride of lead is added. The mixture is melted, and the chloride of silver formed by these means, together with the salt, floats on the top, and can easily be separated from the pure galena. The mixture of chloride of silver and common salt is afterwards melted together with lime and charcoal, or treated in some other suitable manner, whereby the silver and the lead contained in the remaining chloride of lead is reduced. The mixture of silver and lead thus obtained is afterwards separated in the ordinary manner.

Artificial Gold.—Take 16 parts virgin platina, 7 parts copper, 1 part zinc. Place the whole in a crucible, covered with powdered charcoal, and melt until formed into one mass. For a brazing solder, take 12 lbs. of copper, and 11 lbs. of zinc ; flux with powdered brimstone.

Gold, to Dissolve.—2 parts hydrochloric acid and 1 nitric acid (aqua regia) will dissolve gold. Apply gentle heat to

accelerate chemical action. To colour gold, make up 2 dwt. of sulphate of copper, 4 dwt. 12 gr. French verdigris, 4 dwt. sal ammoniac, 4 dwt. nitrate of potassa, acetic acid about 1 oz. Reduce the sulphate of copper, sal ammoniac, and nitrate of potassa to a powder, add the verdigris, then pour in the acid little by little; dip the article in by any convenient means, and heat on a piece of copper till black. When cold, place in tolerably strong sulphuric acid pickle, rinse well in warm water, to which a little potash has been added.

Case Hardening.—For occasional case hardening upon a small scale a very good box may be made by welding a plug into the end of a piece of wrought-iron pipe, and using a loose plug for the opposite end; the loose plug will, of course, require to be fastened into its place with an iron pin passing through it and the pipe; it will require to be luted with clay or loam; part of the plug must project out of the pipe for the convenience of pulling it out.

Composition used in Welding Cast Steel.—Borax, 10; sal ammoniac, 2; flowers of sulphur, 1 part; grind or pound them roughly together; then fuse them in a metal pot over a clear fire, taking care to continue the heat until all scum has disappeared from the surface. When the liquid appears clear, the composition is ready to be poured out to cool and concrete; being ground to a fine powder, it is ready for use. To use this composition, the steel to be welded is raised to a heat which may be expressed by “bright yellow;” it is then dipped into the welding powder, and again placed in the fire until it attains the same degree of heat as before; it is then ready to be placed under the hammer.

Inlaying with Mother-of-Pearl.—Having procured mother-of-pearl of the required shades, and properly cut into thin scales, fasten the pieces on the article to be inlaid with cement, according to whatever design you may have chosen. Then cover the rest of the surface with successive coats of Japan varnish, baking after each coat, until it is flush with the surface of the pearl.

White Metal is an alloy of 10 of tin, 1 of copper, and 1 of antimony. This is a capital composition, running very smoothly; when kept from heating it will last longer than brass, and with a good deal less friction. It was used a great

deal for lining the working-parts of eccentrics, also for the stern tube bearings of screw propellers, before the introduction of the use of timber for this purpose. It is generally cast inside of cast-iron steps, merely as a liner, the low temperature at which it melts rendering it dangerous to make the whole step of this composition, except in cases where the entire bearing is enclosed in a bath of oil or water. It is a fact which has been practically proved, though not generally known, that for extremely high speeds, such as fan-shaft, saw-mills, &c., nothing beats cast iron on cast iron. For locomotive-work, or first-class engine or machine work of any description, nothing is better than what is known by the name of gun metal, which is an alloy of 1 of tin, 1 of zinc, and 8 of copper.

Polished Steel, to Preserve.—You can preserve polished steel from rust by mixing some oil with caoutchouc; melt in a close vessel, stirring to prevent burning. A high temperature will be required. This will form a perfect air-proof skin over the surface, which may very easily be removed by brushing with warm oil of turpentine.

Glazers for Polishing Metal.—There are two kinds of glazers for polishing metal, dry and soft. The *dry glazer* is for doing coarse work, and is constructed as follows:—An outer coating of wood of a uniform thickness, say 2 inches, is secured by means of screws to a cast-iron wheel; the wood must be turned after it is fastened. It is then surrounded by a leather strap, which must be thoroughly soaked in water to make it pliable. The strap is fastened in this manner: a coating of glue is placed on the wood, one end of the strap is nailed to the glazer, the strap is then pressed round the circumference by means of a round iron bar, and at intervals of 3 or 4 inches a row of nails is driven through the strap—these nails are made expressly for the purpose, they are round, with square heads and polished points, to keep them from rusting and make them easily drawn. The strap having been all nicely secured, the glazer is hung up to dry, a process which generally requires a week, in consequence of the soaked state of the leather. When the glazer is dry enough, the leather is coated with glue, the emery is placed on a paper on the floor, a spindle having been attached to the glazer. A man is placed at either end of the spindle, who rolls the glazer over the emery backwards and

forwards, lifting it up and letting it down, in order to make the emery fast, and to cause as much to adhere as possible; it is then hung up to dry, and it is fit for use in a few hours.

The *soft glazer* is made all of wood, except that it is secured by iron bands. The emery in this case is mixed with tallow and formed into cakes. When the emery is to be applied, the workman takes a tool something like a hoe with a hammer shank, and along the cutting edge is a row of teeth; he then strikes the glazer all round, leaving the teeth-marks as thick as possible; he then takes a piece of cake emery and tallow, and presses it all round the glazer; it is fit for use immediately after. No amateur should work on a wood glazer; because if an edge catches the wood, the consequences will be serious.

Breaking Weight of Cast-Iron Rectangular Beams.—

The breaking weight of rectangular beams may be correctly ascertained from data given by Dr Fairbairn. His experiments on 43 samples of hot and cold blast iron bars, each 1 in. square, and supported on bearers placed 4 ft. 6 in. apart, gave, as the average breaking weight, 452·74 lbs.; hence, for any other bar or beam of similar section:—Breaking weight

$W = \frac{4.5^b d^2 s}{b}$ where b = breadth, d = depth, and l = length of

beam, s = the co-efficient above given—viz., 452·74¹ lbs. If the beam be fixed at both ends, it will sustain one-half as much again as when supported.

Preservation of Polished Steel Surfaces.—Polished surfaces of steel and iron may be preserved from rusting by exposure to water, if whilst so exposed they are covered over with a mixture of lime and oil.

Taking Buckles out of Sheet Iron.—The tools generally used are as follows:—A large cast-iron plate, about 2 ft. diameter and 2 in. thick, with the face a little convex (it is called a setter), and a hammer of about 4 lbs. or 5 lbs., about 2 in. flat face. Hammer the sheet iron wherever it is tight, or where it does not buckle, so as to stretch it equal to where the buckles are; by so doing you will bring it flat, but this requires patience and practice. A large plate of iron, as above stated, is the best to set your work out on; because you can more

easily see the extent of the buckle, and where the tie is located that requires to be hammered. The process can be made much easier by passing the sheet iron through a pair of rollers such as are used by tin and iron plate workers.

Preservation of Sulphate of Iron.—Mix 4 parts of pure crystallised sulphate of iron, and an equal quantity of finely powdered gum arabic, with distilled water, and evaporate the solution in a water-bath, at a low heat, till it has a sufficient consistency to be poured out on plates of glass. When it has been poured out in this way, and allowed to dry at a temperature of 30° Cent. in the dark, it may be cut up into lozenges, which can be kept for any length of time in a coloured stoppered bottle.

Composition of Mixed Metals. Pewter.—1. 100 parts of tin, 17 parts of antimony; the French add a little copper. 2. 12 lbs. of tin, 1 lb. of antimony, 4 oz. of copper. 3. 7 lbs. of tin, 1 lb. of lead, 6 oz. copper, 2 oz. zinc. Melt the copper first.

White Metal.—2 lbs. of antimony, 8 oz. of brass, and 10 oz. of tin.

Mosaic Mixture.—Equal parts of tin, bismuth, and mercury, forms a metal used for various ornamental purposes.

Silvery-Looking Metal.—A very fine silvery-looking metal is made from 100 parts tin, 8 parts antimony, 1 part bismuth, and 4 parts copper.

German Titanium.—2 drachms of copper, 1 oz. of antimony, and 12 oz. of tin.

Spanish Titanium.—8 oz. of scrap iron or steel, 1 lb. of antimony, and 3 oz. of nitre. The iron or steel must be heated to whiteness, and the antimony and nitre added in small portions. 2 oz. of this compound are sufficient to harden 1 lb. of tin.

Columbia Metal.— $4\frac{1}{2}$ lbs. of tin, $\frac{1}{2}$ lb. of bismuth, $\frac{1}{2}$ lb. of antimony, and $\frac{1}{2}$ lb. of lead; or, 100 lbs. of tin, 8 lbs. of antimony, 1 lb. of bismuth, and 4 lbs. of copper. This alloy is used for making teapots, and other vessels which imitate silver.

Type-Metal of the French letter-founders: $\frac{4}{5}$ of lead and $\frac{1}{5}$ of regulus of antimony. The letter-founders of Berlin use 11 lbs. of antimony, 25 lbs. of lead, and 5 lbs. of iron. Many

add tin, copper, and brass ; while some make their types from 3 parts of lead to 1 of antimony.

German Silver.—1. 25 parts nickel, 20 parts zinc, and 60 parts copper. If for casting, add 3 parts of lead. 2. 16 parts copper, 8 parts zinc, and $3\frac{1}{2}$ parts nickel. 3. 8 parts of copper, $3\frac{1}{2}$ parts zinc, and 2 parts of nickel. 4. 28 parts copper, 13 parts zinc, and $7\frac{1}{2}$ parts nickel. 5. Copper, 8 parts ; zinc, $3\frac{1}{2}$ parts ; nickel, 3 parts. This last is a very beautiful compound. It has the appearance of silver a little below standard. By some persons it is even preferred to the more expensive compound. Manufacturers are strongly recommended not to use a metal inferior to this.

Speculum Metal.—1. Copper, 32 parts ; tin, 14 parts ; arsenic, 2 parts. A very good metal. 2. Copper, 32 parts ; tin, $13\frac{1}{2}$ parts ; arsenic, $1\frac{1}{2}$ parts. 3. Copper, 32 parts ; tin, 15 parts ; arsenic, 2 parts. 4. Copper, 32 parts ; tin, 15 parts ; brass, 1 part ; silver, 1 part ; arsenic, 1 part. 5. Copper, 6 parts ; tin, 2 parts ; arsenic, 1 part. Sir Isaac Newton's mixture. It is very yellow when polished. 6. Copper, 3 parts ; tin, $1\frac{1}{4}$ parts. Compact, and whiter than the last. 7. Brass, 6 parts ; tin, 1 part. Compact, but too yellow. 8. 2 parts of 6th composition, and 1 part of 7th. Much too yellow when polished. 6, 7, and 8, are experiments by Professor Molyneux, F.R.S. 9. Copper, 32 parts ; tin, 2 parts ; arsenic, 1 part. A pretty good metal, but polishes too yellow.

Mercury, to Extract.—Make a solution of sulphate of mercury by dissolving it in a solution of common salt. Add to this about one and a half or twice its bulk a solution of protochloride of tin (price 3d. per oz.) You will get a white precipitate, which will afterwards turn grey. This is metallic mercury. To collect it, let the precipitate settle, and pour off the liquid : add dilute hydrochloric acid (equal parts of acid and water) to the precipitate, and boil. The mercury will gradually collect into globules.

To Prevent Sand sticking to Articles when Moulded.—Take a little finely-powdered charcoal, in a fine muslin bag, and shake it on the face of the flask of sand after moulding patterns, and before putting the top flask on, and when well dusted with the charcoal, it will prevent them from sticking.

Shrinking of Castings.—For shrinkage of castings, the pattern-maker's rule should be, for cast iron, $\frac{1}{8}$ th of an inch longer per lineal foot; brass, $\frac{3}{16}$ ths ditto; lead, $\frac{1}{8}$ th ditto; tin, $\frac{1}{12}$ th ditto; zinc, $\frac{5}{16}$ ths ditto. The following is the linear expansion by heat from 30° to 212° of—

Antimony, 1 part in	...	923	Iron, cast, 1 part in	...	901
Bismuth, „	...	719	Lead, pure, „	...	349
Brass, „	...	584	Platinum, „	...	1131
Copper, „	...	581	Silver, „	...	524
Flint glass, „	...	1248	Tin, pure, „	...	403
Gold, „	...	682	Tin, impure, „	...	500
Iron, wrought, „	...	846	Zinc, „	...	322

The Amateur's Smelting Furnace.—A simple smelting furnace for brass, &c., is made thus:—

The large vessel No. 1 is filled with sand, to prevent radiation of heat. The small crucible stands on a grate. 1. A large tin vessel; 2. a large pot or crucible; 3. a small crucible; 4. coke, or charcoal; 5. a double blast bel-

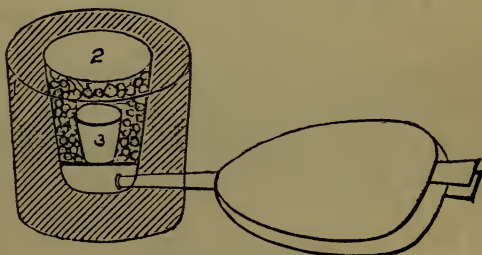

lows.

Tinning.—First cleanse the articles to be tinned by placing them in warm water, mixed with a little oil of vitriol. After washing the articles in clean water, dip them in a solution of sal ammoniac, and let them dry. When they are thoroughly dried, place them in a shallow pan, the bottom of which is full of holes. When the tin is melted, sprinkle a little sal ammoniac over the surface, and dip the pan containing the articles into it. When the smoke has cleared away, take them out, shake them over the pot, and sprinkle a little sal ammoniac over them; then plunge them into cold water.

Bisulphide of Tin.—Kletinsky dissolves 4 parts of salt of tin in 20 parts of water, previously mixed with 2 parts of strong hydrochloric, or 1 part of strong sulphuric acid. This solution is heated nearly to boiling, and then saturated with sulphuric acid gas. The following reaction takes place:—
 $3\text{SnCl} + 2\text{HO} + \text{SO}_3, \text{HO} + 5\text{SO}_2 = \text{SnS}_2 + 2(\text{SnO}_2, 2\text{SO}_3) + 3\text{H}$

Cl. The yellow sulphide of tin is collected on a filter, washed and dried, and the filtrate may be distilled to recover the hydrochloric acid, sulphate of tin remaining in the retort. If the dried sulphide of tin is sublimed at a red heat, access of air being prevented, beautiful mosaic gold is obtained in large shining scales, and spangles of a brilliancy that is never seen with the old way of making the gold.

Oxychloride of Zinc may be prepared by dissolving granulated zinc in hydrochloric acid, and evaporating when a semi-solid hydrated mass is obtained (butter of zinc). The oxychloride is prepared by strongly heating this mass in a porcelain crucible.

Working Poor Ores of Lead.—The operation on lead ores, which contain too little lead and too much earthy matter to be smelted profitably, scientific smelters treat with muriatic acid, with heat, upon plates of stone or lead, by which the galena is completely converted, if the ore has been properly prepared, into chloride of lead. The mass is then lixiviated in tubs with double bottoms, holding each 15 or 20 cwt., with boiling water to extract the chloride of lead, which crystallises out in great part on cooling, the mother liquid being again heated to boiling, and used over again continually. The deposited chloride of lead is reduced to the metallic state by zinc, forming a spongy lead, which may be either melted down or used for

making whitelead, &c. Some iron having been thrown down from the chloride of zinc solution by chloride of lime, the zinc must be precipitated by lime as pure white oxide of zinc, suitable for pigmentary purposes.

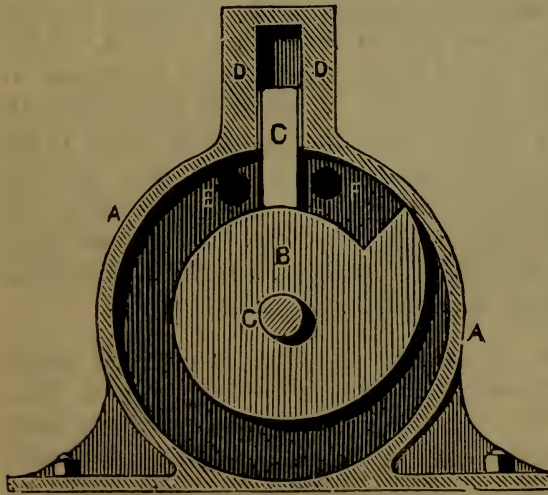

nation shows the principle of a simple Rotary Engine :—

Rotary Engine.

— The following sketch and explanation

AA, cylinder ; B, piston ; C, slide ; DD, slide box ; E, exhaust port ; F, steam port ; G, shaft.

It will be seen that the piston works the slide.

Steam Governors.—The “pendulum ball” contrivance is probably about the best to employ as a regulator, and about the worst to use—as it is ordinarily used—as a governor of machine speed. The following invention simply embodies a plan for employing the “centrifugal principle” in the way for which it is fitted, instead of (as at present in “Watt’s Governor”) the mode for which it is especially unfit.

The apparatus will be easily understood from the skeleton diagrams subjoined.

Fig. 1. A is a box containing a train of clockwork, kept going by a spring or weight, and regulated by the conical pendulum B. The works are wound up every morning when the engine starts, and thus a rotative movement is given to the wheel C throughout the working day, which for all practical purposes may be regarded as invariable.

In fig. 2, A and B are two circular discs, shown edgewise. One face of each, the inner one, is flat.

On the other, a wheel or pulley is fixed, by which rotative motion is communicated. The discs revolve freely and independently on fixed axles. One of these discs, A, receives

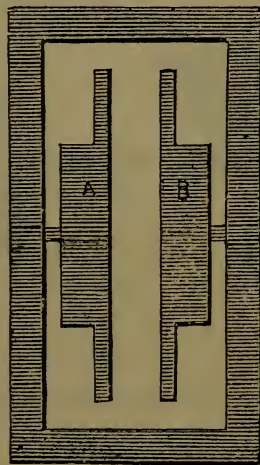
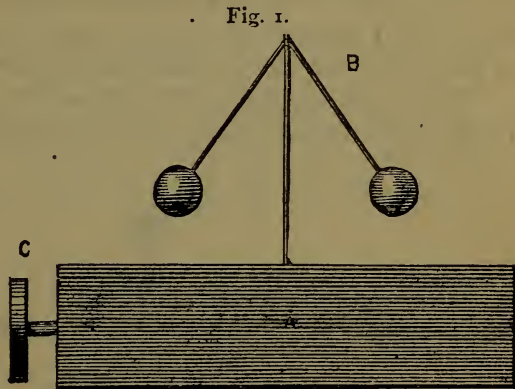

Fig. 2.

its rotation by a strap from wheel C in fig. 1, and therefore revolves at a regular rate. Disc B in like manner receives rotation from the engine. The discs are so fixed that thin flat surfaces revolve in parallel planes, but in opposite directions. Through the fixed axles central holes are drilled to receive the spindle of the "governor," shown in fig. 3, where A is a spindle carrying an arm B, which is crowned by a wheel C, revolving freely on its centre. The length of the arm B is rather less than the radius of the discs A and B in fig. 2; and the diameter of the wheel C is just equal to the distance between those discs. All these dimensions, as well as the velocity of rotation of the discs, are merely matters of convenience.

When put together, the ends of the spindles pass through the holes in the fixed axles, and play freely in them. The arm B

Fig. 3.

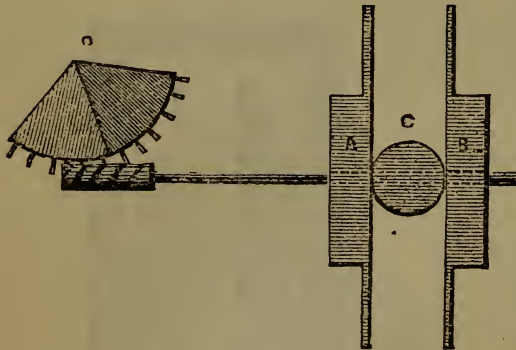
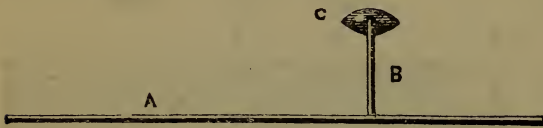

Fig. 4.

projects between the discs and the wheel C, which traverses round near their outward edge, and is pretty tightly clipped by them. Its rim is belted by a ring of vulcanite, or other elastic material, so as to establish a good bite. One end of the spindle projects beyond the framework, and carries at its extremity an endless screw, which works into the teeth of a quadrant D, connected with, and

governing, the throttle-valve. The wheel arrangement is shown in fig. 4. The action of the instrument is very simple. So long as the "engine" disc keeps time with the "chronometer" disc, its "governor" wheel C will simply revolve on its axis, keeping the spindle, and therefore the throttle-valve, fixtures in their existing position. When any change of power or load occurs,

and the engine disc begins to gain or lose, the "governor" wheel at once begins to traverse round the circle, carrying with it the spindle, and thus acting on the throttle-valve until a new point is reached, when the disc velocities are again equal; and there it remains until new conditions supervene requiring fresh adjustments.

By this means the engine disc can never vary in velocity from the chronometer disc for more than a few seconds at a time, while the process of adjustment can be made as prompt and delicate as any practical necessities may require.

Preventing Incrustation in Boilers.—Mr William Irwin's invention of "an improved compound for preventing incrustation in boilers," consists in the mixing with the water in a steam boiler a compound composed of the following ingredients, which, by preference, are mixed together in the following proportions:—

French ochre.....	3	lb.
Oxford ochre.....	4	"
Brown ochre	4	"
Yellow ochre	3	"
Vandyke brown.....	4	"
Spanish brown	1	"
Purple brown.....	2	"
Ground umber	1	"
Ground ochre.....	3	"
	4	"
	<hr/>	
	6	lbs.

The above proportions mixed in a gallon of water, and put into a boiler 17 by 5 feet, will prevent incrustation.

Another plan is to introduce a small quantity of chloride of ammonium, when the lime which forms the incrustation will be held in solution, and the boiler cannot foul. The process is equally applicable to fresh or salt water. This will effect a saving of time, heat, and fuel, and, more than all, will prevent one of the principal causes of explosions, for it has been proved that, in most instances, the foulness of the boiler has been the principal cause of accident.

Much of the "fur" in boilers depends on the chemical composition of the water used. Sometimes a pound of common soda, introduced daily, has been found to prevent incrustation. This for driving a 20 horse-power engine. The deposit is in

the state of powder. Two months is too long to work a boiler without cleaning, except in rare cases. To introduce the soda,

have a small cistern connected with the pump, dissolve in the cistern, and then turn on your tap.

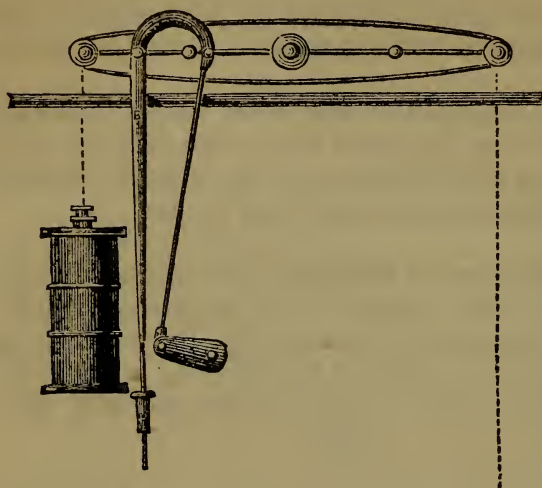

Blast Engine.—

In the following, the swan-neck rod should be made of two flat, tapering bars. In the sketch the crank is represented as working 6-foot stroke, and the cylinder working 8-foot stroke.

Self-Acting Boiler Feeder.—The figure is a section of the apparatus. The water from a cistern enters the cylindrical reservoir A through the pipe E, closed by a valve B opening upwards. The water passes into the boiler through the pipe H, closed at top by the valve C opening *downwards*, and closed by a slight spring.

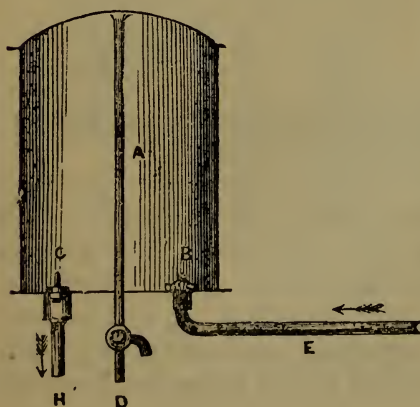

D is a small steam-pipe reaching to the top of the reservoir, and having a 3-way cock where shown. The action is as follows:—On turning the 3-way cock a communication is opened between the cylinder and the outer air; the water then enters through the valve B, and fills the reservoir, ultimately escaping through the lateral opening in the 3-way cock. This shows the reservoir is full. On now turning the cock, the lateral passage is closed, and the direct communication opened from the boiler through the steam-pipe D. Equilibrium of

Equilibrium of

pressure being thus established, the water descends through the valve C and pipe H into the bottom of the boiler. On again reversing the cock the steam escapes, and the water enters as before.

The only thing to be done, therefore, is to turn the small cock at certain intervals, and this may be arranged by letting the water that overflows through it when the reservoir is full fall into a receiver so arranged as to tilt over when full, and in tilting over turn the 3-way cock. The whole would thus become entirely self-acting.

Engine Governor.—To make a governor that will work correctly and show its speed, mark a diagram of the governor, showing the centre lines only,

when in its proper working position, viz., with the balls half expanded. If the centre line of the long arm be expanded until it cuts the centre line of the spindle, we are able to measure by a scale, on the rule, the distance from the horizontal plane of the balls up to the point in the spindle where it is cut by the extended centre line of the arm; this distance is the vertical height, on the length of which depends the speed of the governor. The rule now is—

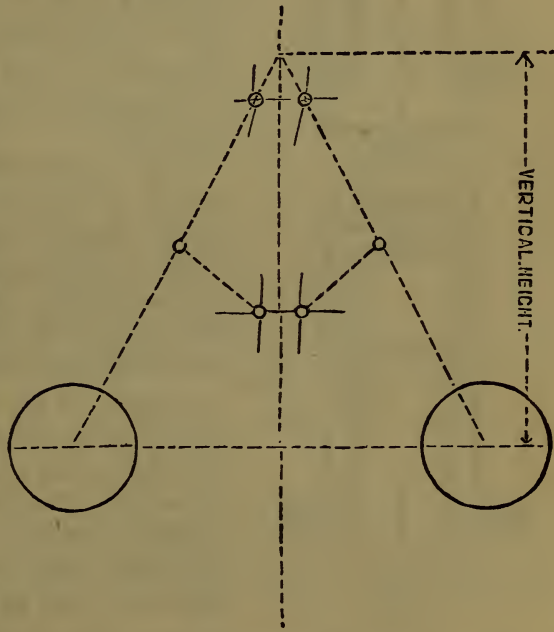

is—

$$\sqrt{\frac{187.5}{\text{vertical height in inches}}} = \text{revs. per min.}$$

This gives the correct speed of the governor, and that of the engine being also known, before the required size of the wheels can be at once determined upon.

Expansive Governor for Steam Engines, &c.—It frequently happens in many manufacturing operations that great variations occur in the work which the engine has to perform, and in all cases it is desirable that the steam should be used in the most economical manner. With the use of the ordinary throttle-valve this desirable result is not effected, inasmuch as the retardation is caused by expansion of steam before admission into the cylinder, thus losing the full benefit of the high pressure stored in the boiler at so much risk. In order, therefore, to economise in this respect to the fullest extent, the steam should be admitted to the cylinder at full pressure, and the required diminution of speed effected by a proportionate duration of the admission. Such a variable “cut off” is produced by the invention we now describe.

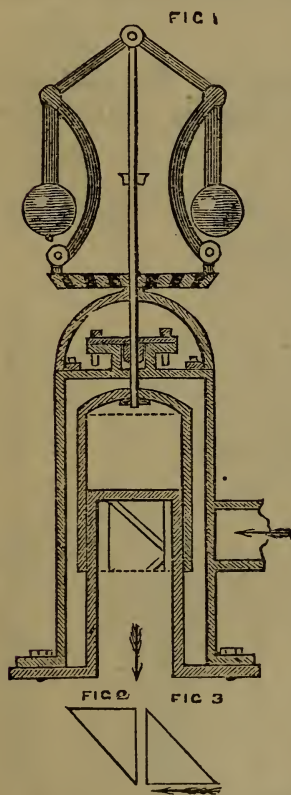

Fig. 1 (the bottom of which is the top of the slide-valve case of a horizontal engine) has cast with it the small upright cylinder, closed at top, communicating with the valve-case. The upper half of this has an opening extending about half-way round, which is shown as fig. 2. Over this, and fitting with proper ease, is another cylinder, open at both ends, and to a cross-bar at top is fixed the rod proceeding upwards, and working with the bent arms of the governor. At the lower half is a cavity, as seen in fig. 3. Over these is bolted down the cylindrical steam-case, provided at the

side with steam-pipe and at top with stuffing-box, and also with support for the bevil-wheel actuating the governor. The revolutions of this wheel being made, by suitable means, to correspond with those of the main shaft, and proper adjusting weights placed upon the small shelf provided on the rod, going through the stuffing-box, the effect will be that, as the centrifugal force depresses the said rod, so will the openings before

described correspond for a shorter time, and the speed be regulated as desired. The effect will be better understood by referring to figs. 2 and 3, where, supposing fig. 3 passed across fig. 2, in the direction of the arrow, represents the steam on during the whole stroke, then by depressing fig. 3, and passing it across as before, the inclined sides are brought nearer together, and hence the "cut off" takes place sooner. The lower part of fig. 1 is in section.

The Giffard Injector consists of three cones, A, B, and C. B is the combining cone, A the steam cone, and C the receiving cone. The steam cone can be moved nearer to or further from the combining cone, which is fixed with its small end at a short distance from the receiving cone C, and the supply of steam can be regulated by the rod D, worked by the hand-wheel *k*. F is the steam-pipe opening into the steam cone above; *g* is the water-supply pipe opening into cone B. H is the overflow-pipe opening into an annular space *oo*, surrounding the ends of the cones B and C, finally I is the valve opening into the boiler.

The action is as follows :—The steam rushes through pipe F and cone A. Now take, for example, the case of a boiler working at a pressure of 60 lbs. per square inch from a vacuum.

A cubic foot of steam at the atmospheric pressure will weigh .047 lbs., therefore the weight of a cubic foot of 60-lb. steam

60

will be equal to $— \times .047 = .188$ lbs.; also the weight of a

15

cubic foot of water is 62.4 lbs. Now the velocity of issue of a fluid under pressure is equal to the velocity of a body falling from a height equal to the height to which a column of the fluid would be raised by the pressure in question, which for 60-lb. steam

will = $8 \sqrt{\frac{60 \times 144}{.188}} = 8 \sqrt{44800} = 1712$ feet per second. Also for

the water velocity will = $8 \sqrt{\frac{60 \times 144}{62.4}} = 8 \sqrt{138.4} = 94$ feet per

second nearly. Now, suppose 1 cubic foot of steam coming out of the steam cone with a velocity of 1712 feet per second to be condensed between A and B, it would form about four cubic inches of water, which would retain the velocity of the

steam ; and as this is rather more than 18 times greater than the velocity of the water issuing direct from the boiler, if it is mixed with about 16 times its bulk of water, it would still have a velocity rather greater than 94 feet per second, so it would easily open the valve and enter the boiler.

Now this is exactly what happens in the injector. Steam being turned on, rushes through the cones A and B, and escapes at the overflow-pipe H ; but by the well-known principles of hydrodynamics, it induces an upward current of water

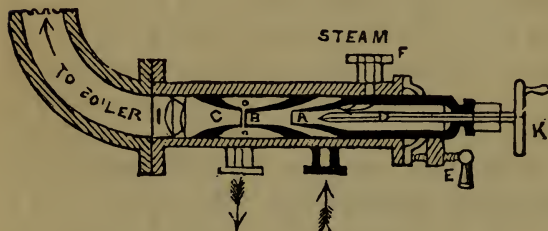

in the pipe *g* : and as soon as the water reaches the cone A, it will begin to condense the steam, and, by the principles already explained, if the bulk of the condensed

steam and water be not greater than about 17 times the bulk of the condensed steam, it will open the valve T and enter the boiler.

If the supply of water be too great, and the velocity thereby too much reduced, it will rush out of the overflow-pipe H instead of entering the boiler, and thereby give warning to the engineman to reduce the supply of water by moving the cone A nearer to the cone B, by means of the handle E, until the water just ceases to drip from the pipe H. If more water be wanted for the boiler, the pointed rod P is drawn further back to admit a larger quantity of steam, and the cone A also drawn back till a slight drip comes from the pipe H, when the injector will be working to its greatest effect. It is evident that the quantity of feed-water must in all cases be sufficient to condense the steam, and that the water must not be heated to more than about 110° Fahr., or it will not condense fast enough—or rather, the quantity required will be too great for the steam to take into the boiler with it.

Huxley's Internal Tappet Pump or Steam Engine.—As a pump this will be found specially useful in deep wells, where frequently much inconvenience, loss of time, and expense arises from the defective action of the ordinary valves, also necessi-

tating the descent of some one down to the pump. Here we have a lift and force pump, of double action, with the requisite changes effected by a tappet piston in place of valves, whose action is as certain as the revolution of a crank and fly-wheel, the necessary appendage to the piston-rod, &c. Fig. 1 is the ordinary cylinder and piston, the cover, however, having a long neck to the stuffing-box in order to allow of the movement of the tappet, which is fastened to the piston-rod, and may be seen just under the stuffing-box. At the side, near the top of cylinder, are three ports, as usual; but the ports are altered in arrangement, as may be seen. The exit port *b* also communicates with the top of piston, through a circular passage made in the tappet piston before referred to, and surrounding the piston-rod. The action is as follows:—The piston having ascended to the limit allowed by the crank, has pushed the tappet piston to near the top of cylinder, and is ready for descent.

Supply port *a* is in communication with top of piston, causing it to descend; exit port *b* communicates with port *c* through a cavity, which is seen on the side of the tappet piston, and thence descends a passage and opening *c* to bottom of piston. The piston having next arrived at bottom of cylinder, the tappet has just pushed against a cross-bar provided at the bottom of tappet piston, and its position is seen in fig. 2, where exit port *b* communicates through the passage described in tappet piston to the top of piston, and supply pipe and port *a* with port *c* leading to bottom of piston, and thus proceeds the up-stroke, and produces the arrangements before described ready for another down-stroke.

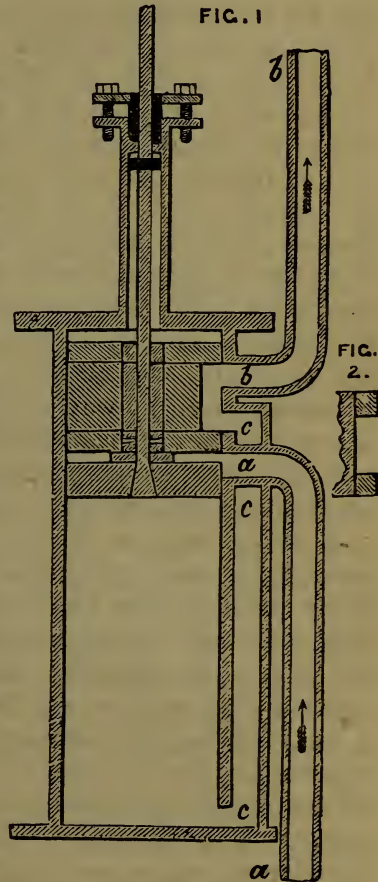

Power of Engines.—It is frequently asked, What is the power of an engine of such-and-such dimensions? The question will be answered by a glance at the following rules, which, amongst many others, are used for ascertaining the horse-power, will explain the vague and uncertain methods we have of solving such a problem. In Chambers's "Mechanics," the rule for non-condensing engines is, Multiply the area of piston in inches by the pressure per square inch in cylinder, less 15 lbs. for the pressure of the atmosphere on waste-steam pipe. Then, by the velocity of the piston in feet per minute, divide by 33,000, and $\frac{4}{5}$ of the quotient is the effective power. Templeton's rule for high pressure is, Multiply the area of piston in square inches by the average force of steam in lbs., and by the velocity of the piston in feet per minute. Divide by 33,000, and $\frac{7}{10}$ of the quotient is the effective power. Bourne gives the following rule for high pressure :—Square the diameter of the cylinder in inches, multiply by the pressure of the steam in the cylinder per square inch, less $1\frac{1}{2}$ lb., and by the piston's velocity in feet per minute. Divide by 42,017 : the quotient is the effective power. The first-mentioned rule is merely given by way of illustration, as the pressure of the atmosphere is not generally taken into account, engines of this principle being supposed to work in a medium. The rules for ascertaining the nominal power are equally fallacious. For condensing engines Bourne gives the same rule as for non-condensing, considering that the deduction of a $1\frac{1}{2}$ lb. is relatively much smaller where the pressure is high, than where it does not much exceed the pressure of the atmosphere. Lardner gives the following rule :—When the pressure in the cylinder does not exceed the atmosphere more than 4 lbs. or 5 lbs., with a good vacuum, and an average of 200 feet per minute for the velocity of the piston, square the diameter of the piston, and divide by 28 : the quotient is the horse-power. The Admiralty rule is, Square the diameter of the cylinder in inches, and multiply by the speed of the piston in feet per minute. Divide by 6000 : the quotient is the horse-power.

Safety-Valves.—Many and various are the plans that have been adopted and suggested for producing perfect safety-valves for steam engines. Without an effective and reliable safety-

valve, the use of a steam boiler must be constantly attended with the most imminent danger. Whatever care may be bestowed by the manufacturer on the construction of the safety-valve, it may be rendered nugatory by the ignorance or temerity of the person in charge of the engine, since he may overload the valve, and thus create a pressure within the boiler which it was not constructed to endure, and which it may not be capable of bearing. The evil may, indeed, be prevented by the use of two safety-valves, one of which is beyond the power of the engineman. But ingenuity has devised a still more simple remedy; one that not only prevents the production of steam at too high a pressure, but which actually causes every attempt to produce it to be accompanied by a reduction of pressure, and thus removes all temptation to tamper with the valve. The new form of safety-valve differs little from the ordinary kind, and is extremely simple. In the ordinary kind the fulcrum of the lever is absolutely immovable, in the new kind it is fixed; in ordinary circumstances, being kept down by a spiral spring. But attempting to overload the valve brings the lever down on a stud, which is at the side of the valve most remote from the fulcrum, and which comes into action as a new fulcrum by supporting the lever, changing the latter from the third to the first order. The former fulcrum yields to the additional weight, the spiral spring being compressed, and is raised up, the safety-valve being at the same time opened, or allowed to open; and thus the steam is permitted to escape, though at a pressure too small to raise the valve when weighted as it should be. In its normal state, the fulcrum of the lever is at one end, the weight at the other, and the power—that is, the tendency of the safety-valve to rise—between the fulcrum and weight. When the valve is overloaded, the weight—that is, the resistance of the spiral spring—is at one end, the power—that is, the weight with which the lever is loaded—is at the other, and the fulcrum—that is, the stud on which the lever has been brought down by the overloading—is between the power and weight, the effect of the latter being aided by the tendency of the steam to raise the valve. A notice of some of the most recent, therefore, cannot but be interesting to mechanics and engineers. First, we have

Mr Swann's Patent.—In this case, the apparatus is so arranged that undue weight applied to the lever of the valve, in

place of allowing an increase of pressure in the boiler, will cause the steam to blow off at any pressure to which the apparatus may be set. In place of arranging the valve lever to turn on a fixed centre as usual, the centre or axis is arranged in such a manner that it is kept down only by a spring or weight, which yields

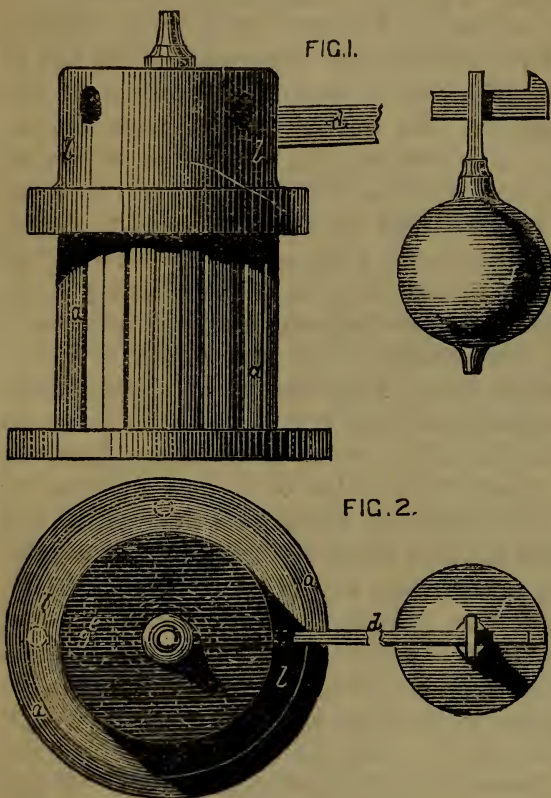

when undue pressure is applied at the other end of the lever; the outer arm of the lever then descends a short distance till it comes against a fulcrum arranged for it between the valve and the weight, and then the undue weight applied to the lever aids in taking pressure from the valve. The inner end of the lever, with its centre or axis, is cased in so that it cannot be tampered with. The same arrangement is applicable where an adjustable spring is

applied to the outer end of the valve rod in place of a sliding weight.

Fig. 1 is a side view, fig. 2 a plan, and fig. 3 is a vertical section of a safety-valve constructed according to this invention.

a a is a casting secured by bolts to the top of the steam chest; *b* is a bushing of brass fitted into it to form the valve seat; *c* is the valve, held down by the weight lever *d*, which turns at one end of the pin, *e*, and at the other receives the sliding weight *f*, and by sliding this weight on the lever *d*, the

pressure on the valve may be varied as desired. g is the fulcrum to which the lever d is jointed by the pin e , and this fulcrum is made so as to yield when a heavy pressure is put upon it. Its stem, g^1 , drops into a socket bored to fit it in the casting a , and in a space within this casting the stem, g^1 ,

FIG. 5.

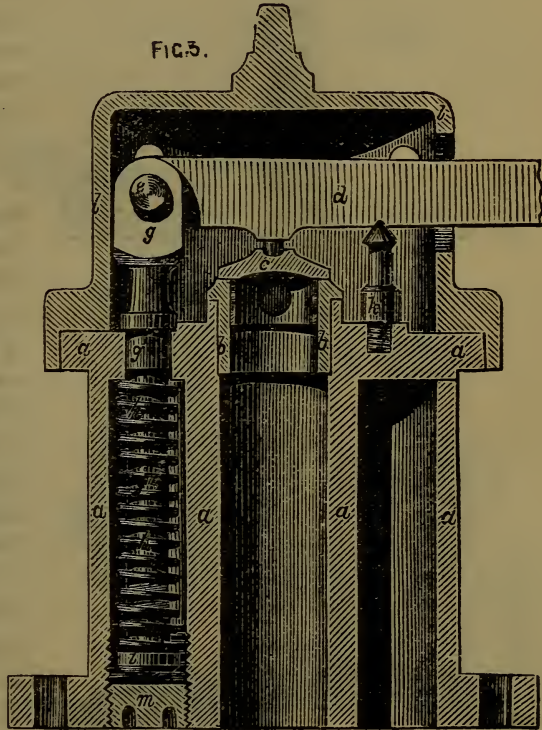

receives the spiral spring h , which is retained by the nut i on the stem, so that, as will be seen, by screwing up the nut i , the fulcrum g may be held down in its socket with any desired force. A convenient way of adjusting the spring h is to place a suitable weight, f , at the end of the lever, and to screw up the spring i until its tension is just sufficient to hold down the fulcrum g ; k is a stud or stop fixed in the casting a , in such a position that, as soon as the fulcrum g commences

to yield in consequence of an excessive weight being applied to the lever d , the said lever may come down on to the stud, which then acts as a new fulcrum, and the excessive weight applied then assists the pressure of the steam in lifting the valve; l is a cover with openings in it for the passage of the lever d , and for the escape of the steam; it is secured by screws or otherwise to the casting a , so that the valve may not be tampered with; m is a screw plug, which closes the recess in the casting a , in which the spiral spring is contained.

In connection with safety-valves arranged according to this invention, apparatus may be applied to indicate when the

water in the boiler is deficient by causing the steam to escape from the valve. Fig. 4 shows, partly in section, apparatus for this purpose; n is a bushing screwed into the top of the boiler,

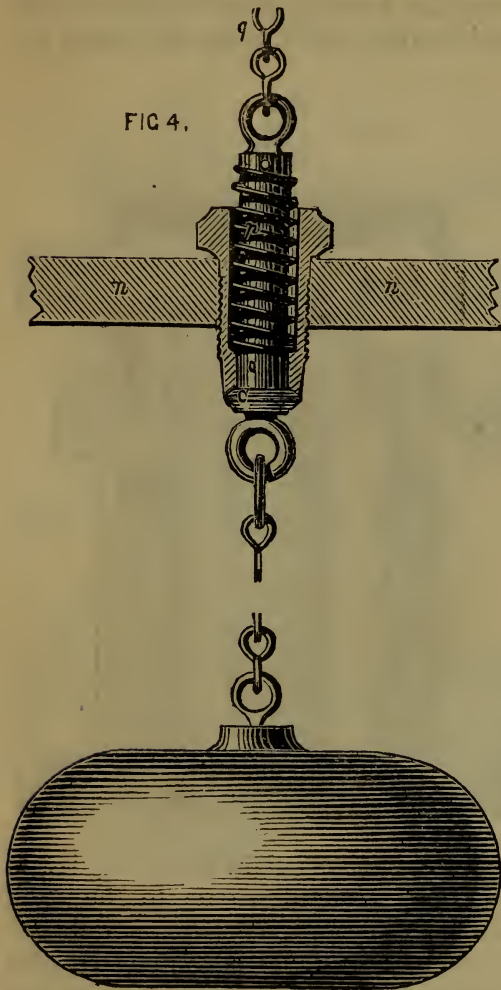

and o is a plug passing freely through it; a valve, o^x , is formed at its lower end, and this, resting against a face at the lower end of the bushing, prevents any escape of steam; p is a spiral spring, which tends constantly to draw the valve o^x up to its seat; q is a chain connecting the upper end of the plug o with the outer end of the weight lever d of the valve; r represents a heavy float connected by a chain with the lower end of the plug o , and which should rest on the surface of the water in the boiler; when, however, the water falls too low, this float, being unsupported, its weight draws down the plug o , and by the chain q the weight of the float is transmitted to the lever d , and this additional

weight causes the pressure on the safety-valve to be relieved, as already explained.

What is claimed is the arranging the parts of a safety-valve, as hereinbefore described, and especially the combined application to safety-valves of a yielding fulcrum for the valve lever, and a stud or stop to receive and support the valve-lever as soon as the fulcrum commences to yield.

Peet's Invention.—The accompanying illustration represents a valve patented by Mr S. J. Peet, of New York, which is well spoken of on account of the simplicity of its construction and the ease with which it may be repaired.

From the engraving representing the valve in section, it will be seen that the two discs serving to close the valve are raised or depressed by means of the hand-wheel and upright stem B. These discs are suspended on the stem by its collar engaging with the semicircular recesses on their inner faces, and prevented from separating

from the stem by the walls of the passage in which they move. The lower face of the collar, B, and the lower portion of the recesses in the discs are made slightly conical, so that, after the discs have reached the bottom, any further pressure on them by the screw of the stem forces them apart and firmly against the walls of the valve, thoroughly closing the apertures of the pipe. The conical collar, there-

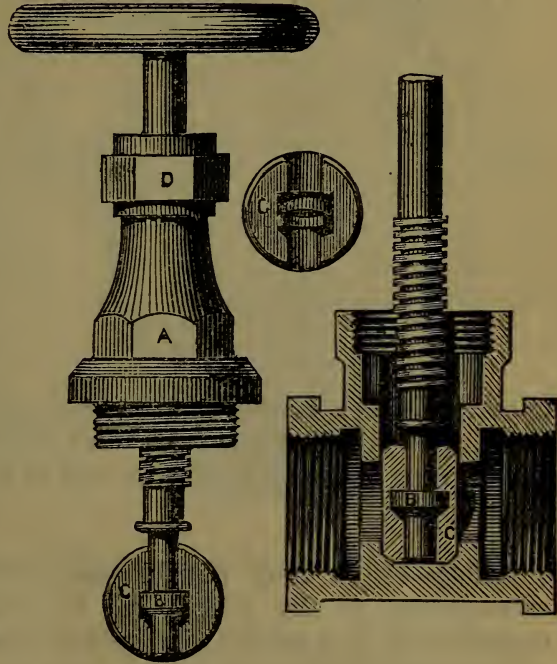

fore, acts as a wedge aided by the pressure of the screw. It will be seen that both sides of the pipe are closed by this means, making this a back-pressure valve as well as a direct acting gate. When the discs are raised, a free passage, without change of direction, is made through the valve for the steam, water, or gas, of the full size of the pipe. The stem is packed in the usual manner by the screw gland D.

Safety-Valve Balance.—This is the safety-valve and balance used on the principal railways. The lever D, fig. 1, is affixed

to a spring-balance A, graduated to the pressures per square inch due to the spring. By turning a nut B on the stem of the spring-balance, any required pressure can be thrown upon the valve, which is kept down by the spring acting on its lever. Should the pressure within the boiler exceed that to which the balance is adjusted, the valve is opened, and a portion of the steam escapes. The lock-up safety-valve, fig. 2, consists of a

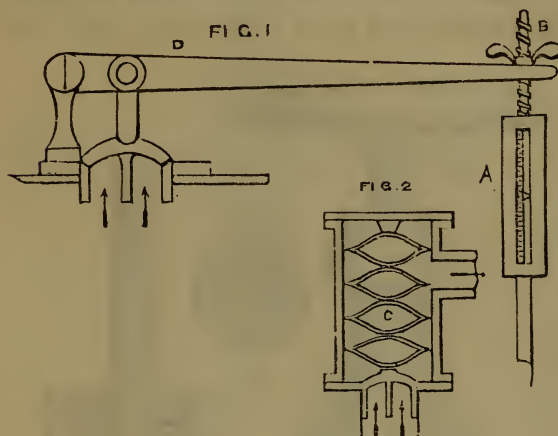

valve pressed down by a set of strong springs C, the whole enclosed within a box under lock and key. While the engine-driver has command over the spring-balance valve, so as to increase or diminish the load at pleasure, the lock-up valve is inaccessible to him, and

opens whenever he has loaded the open valve beyond the pressure to which the lock-up valve has been adjusted; thus serving as a check upon him in case of his working at a dangerous pressure.

Safety-Valve and Superheater.—The following is the arrangement of the safety-valve in general use in marine engines:—A is a handle with socket attached, the outside of which socket fits into the top of dome or upper part of valve-chest B, and internally fitting the valve-spindle E. D, D, &c., are the lead weights entirely enclosed in the valve-chest B, C, which is generally cut in two for the purpose of removing the weights on examining the valve and seat F, G. Now for its action through the sockets of A and the upper end of spindle E, a cotter is fitted loosely and bored in the point to receive a pad-lock, the key of which is given in charge to the captain of the vessel. It will be seen that the cotter hole in spindle is much longer than that of the socket A, which allows the valve and weights when counterbalanced by the pressure in the boiler to

rise sufficient to allow a free escape of steam, independent of being eased by hand in the engine-room, which can be effected as shown by the dotted lines. As the cotter rests on the top of the projection of B, it allows the valve to be moved freely on its seat at any time, and at the same time preventing any weight that may be placed on A from taking effect on the valve. The superheater is used for the purpose of drying the steam immediately after its generation in the boiler, and to prevent as much as possible the condensation of the same while on its passage from the boiler to the cylinder.

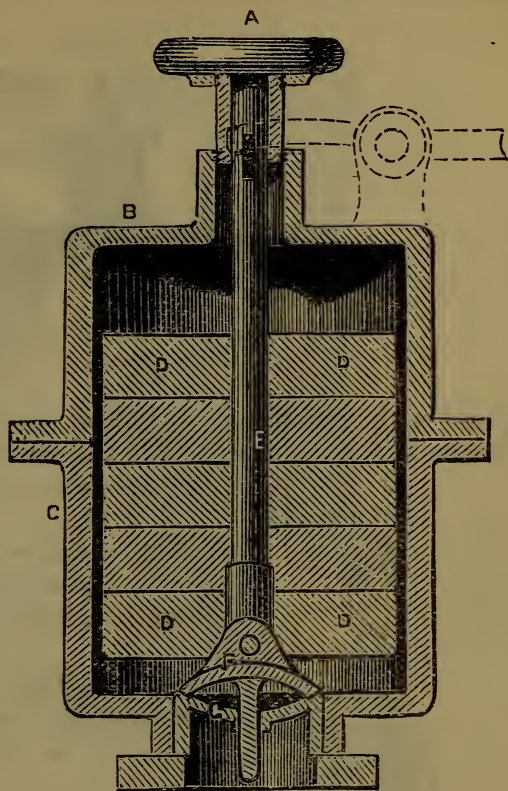

New Slide-Valve.—This equilibrium slide-valve is intended

FIG. 1.

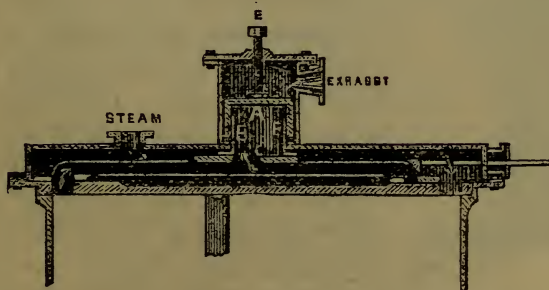

to prevent the waste of steam in the ports of cylinders. C is

the face on the back of valve BB, the movable face and exhaust-pipe E is the set screw to screw down the packing

FIG. 2.

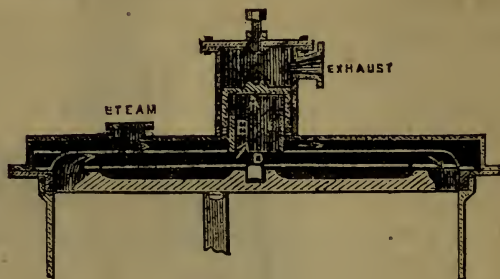

gland with crossbar A. Another modification of the valve is shown at No. 2; the ports in this valve are placed to one side of the valve face, and the exhaust-pipe BB is cast to the back of the valve, which oscillates on the centre stud D and exhaust-pipe BB, covering alternately the top and bottom ports.

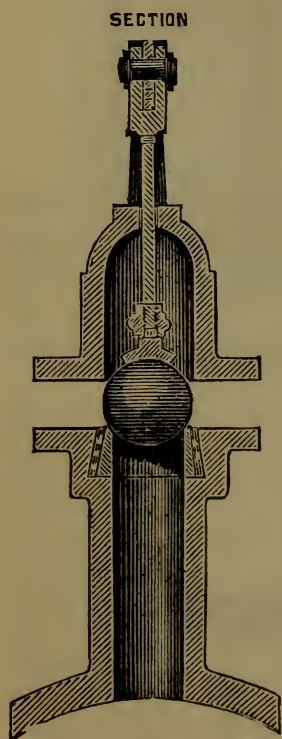

Safety-Valve.—This safety-valve is designed for a small cylindrical (model) boiler, 12 in. in diameter by 24 in. in length.

The valve, with its seat and dome, are of brass. The ball, may either be solid or hollow. Being a true sphere, it is perfectly free to move in its seat, without the possibility of sticking, whenever the pressure of steam in the boiler is beyond that for which the lever is weighted. The dome serves to protect and guide it in its seat.

A serious objection to many of the valves now in use, particularly those of the "mushroom" form with stem and guide, is their liability to stick, and disastrous results have often happened from this defect. Perfect freedom of action and non-liability

to stick, are therefore important features in the construction of a safety-valve. The principle of the ball valve is not new.

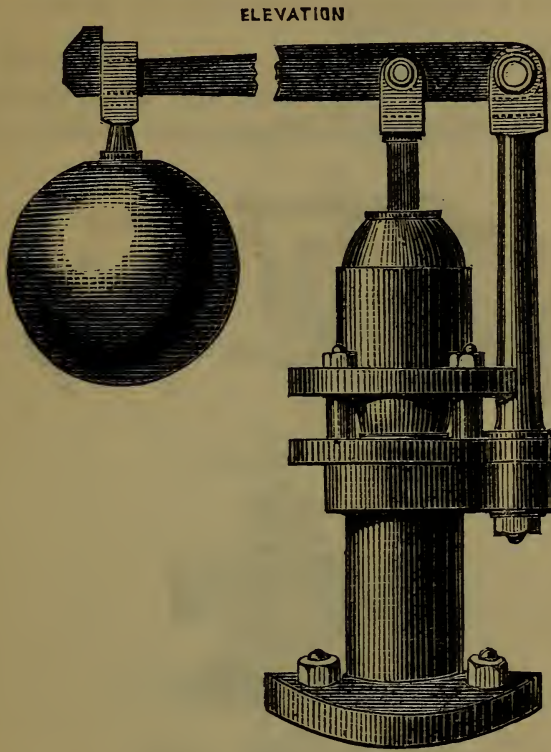

A New Safety-Valve.—The following is a design for a safety-valve which will register the pressure of steam as well as

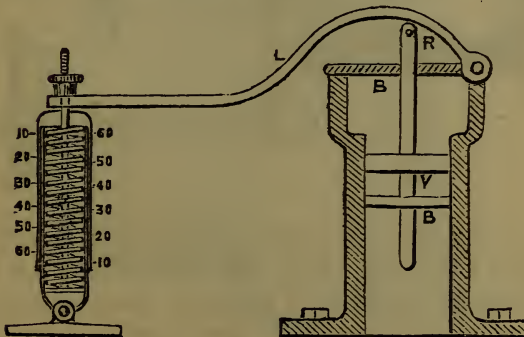

allow it to escape :—The valve, it will be perceived, ascends as the pressure increases, and descends as the pressure decreases.

BB are two bars fixed for the valve-rod to slide through to guide. At the top of the valve-rod R, there will be perceived a small roller to make it run free under the lever L.

Slide-Valve Motion.—Many possessors of small cylinders—say $1\frac{1}{2}$ -in. bore and 3-in. stroke, with steam chest on top—are puzzled to know how to communicate motion to the slide-

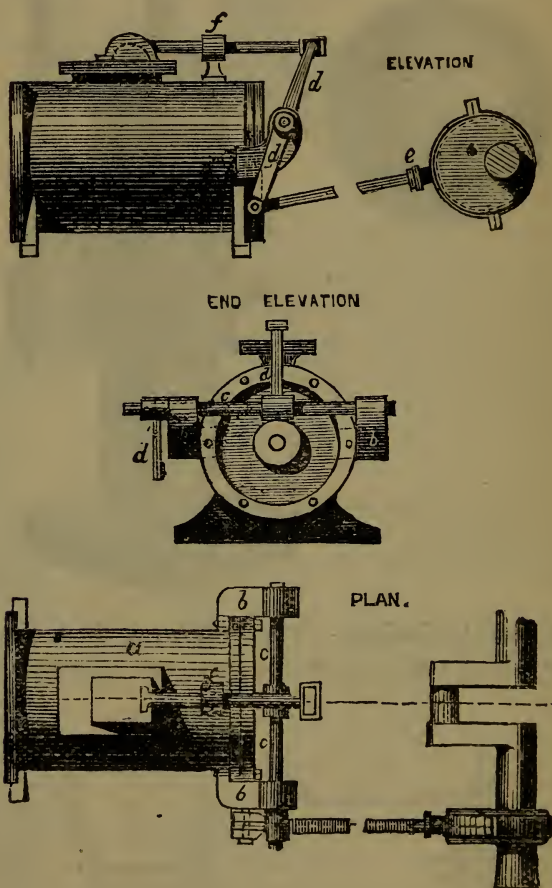

valve, so as to be out of the way of the crank and the connecting-rod. The following plans will suffice:—*a*, the cylinder, *b*, brackets screwed on back of cylinder flange carrying shaft *c*, on which is fixed two arms *d'd*, one connected with the eccentric and the other to give motion to the valve. The arm *d'* has a slot for changing the length of stroke; the connecting-rod

is screwed into the eccentric strap for setting valve with the nut *e* for tightening when set, *f* is the support for valve-rod.

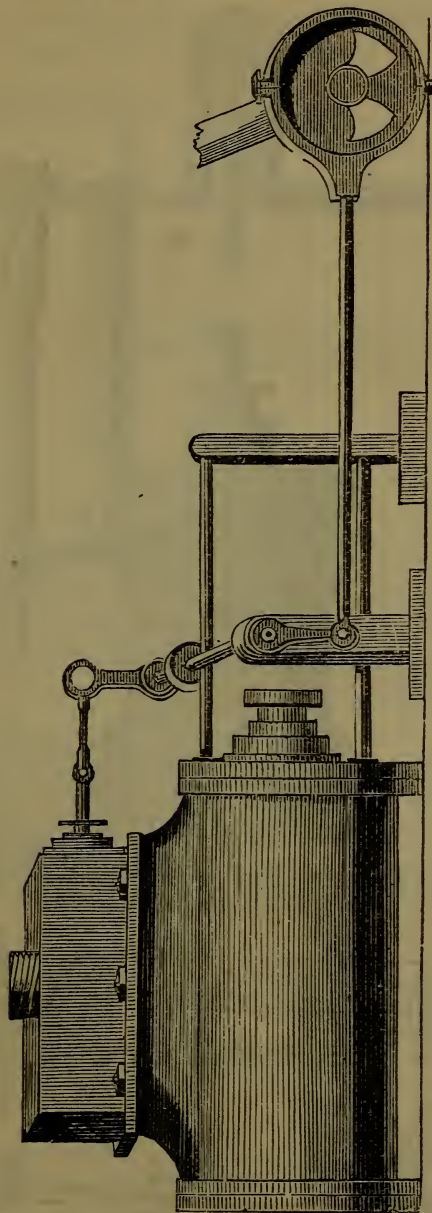

Another method is shown in this diagram, which sufficiently explains itself.

Another plan: A, Crankshaft; B, fly; C, eccentric; D, horizontal lever with eccentric-rod on one end, valve-rod on the other.

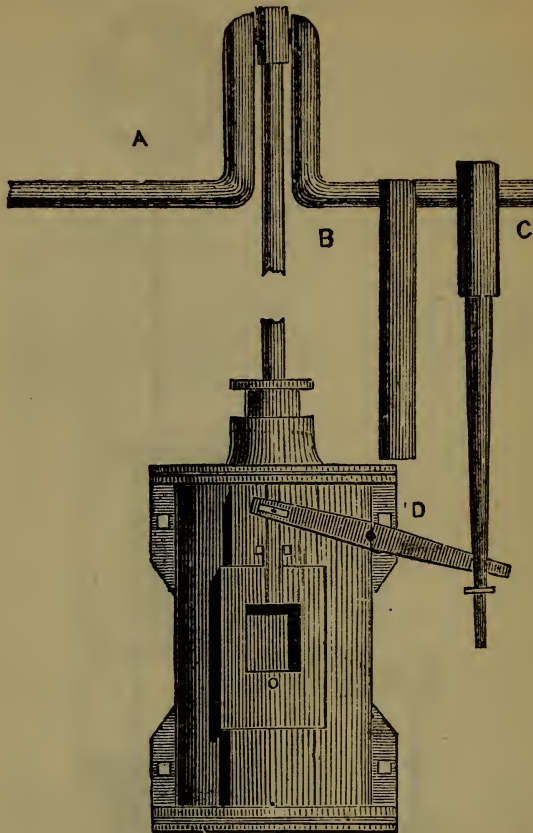

The following plan is generally adapted to cylinders with valve on top :—It is a spindle on brackets, with lever near the

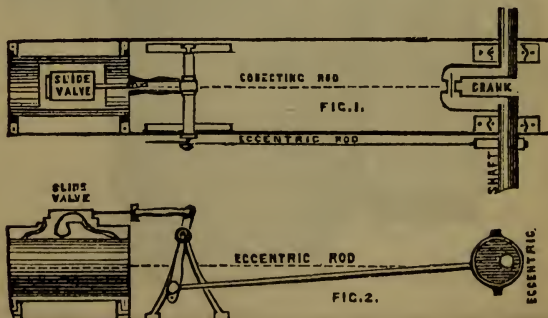

middle, connected with the valve-spindle by two links. A nut,

with a pin formed on each side, is taped and screwed on the valve-spindle, in order that the valve may be set to a nicety to the end of the spindle, fig. 3. Another lever is fixed, with a long hole at the end, and a pin is inserted on which hangs the

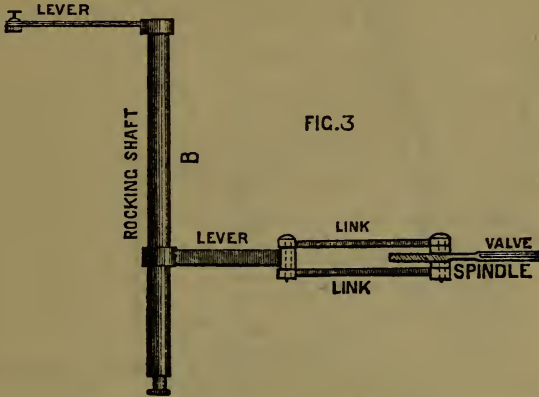

eccentric-rod. By having a long hole and movable pin, the stroke of the valve may be set to the desired length. Fig. 1 is a plan; fig. 2, elevation; fig. 3 shows the rocking-shaft or spindle laid with the levers and links attached to the valve spindle.

Another method is shown in next diagram:—A is sole plate, B cylinder, C connecting-rod, D rocking-shaft, E levers on

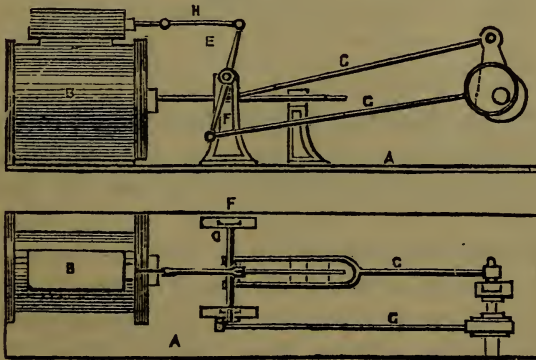

rocking-shaft, F pedestals to carry rocking-shaft, G eccentric-rod, H connecting-rod for slide-valve.

Reversing Motion in Engines.—The following is a simple arrangement for altering an engine, so that you may reverse it at will, which can be done according to this plan with one

eccentric, and doing away with eccentric-rod, and using a longer valve-rod and a link :—Fix a plate to the eccentric-strap, and also a link (as will be seen in sketch) extending from D to D'.

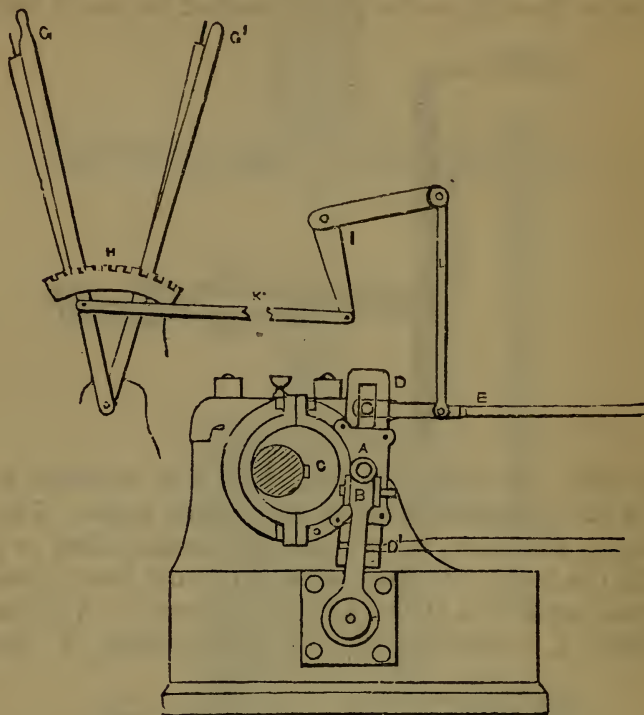

B is a rock-shaft working on a pin fixed to centre of plate, it and another pin fixed at F on a plate bolted to engine-stand. When the engine is at work the rock-shaft will give motion to link as if using two eccentrics ; and by moving the lever G to the dotted lines G', the sliding-block will be moved from its position at top of link (as seen in sketch) to the bottom of link, and so alter position of slide-valve and reverse the engine ; and by moving the lever G into some of the notches marked at H, the travel of valve will be short, and so allow the steam in cylinder to expand by closing the ports sooner, and allowing less steam to enter the cylinder. The parts G, H, J, K, and L can be fixed to engine-frame or stand in any position best suited to the plan of engine.

Setting the Slide-Valve.—First, the steam is to be shut

off a little before the end of the stroke by closing the aperture of the steam-port which causes the piston to be brought gradually to rest without jarring the engine. Secondly, the eduction-port or passage to condenser should be closed before the end of stroke, which is called "cushioning" the piston, because it then completes the stroke against an elastic air-cushion in consequence of a portion of uncondensed vapour being shut up between the piston and the top or bottom of cylinder. Thirdly, the steam-port on the same side of the piston should be opened a very little before the end of the stroke, so that the steam may have acquired its full pressure as soon as the crank shall have turned the centre; and lastly, the communication with condenser should also be opened on the opposite side of the piston a little before the end of stroke, so as to have a vacuum ready made in the cylinder before the return stroke begins.

Boiler Feeding.—Several modes of feeding a boiler without a pump have been suggested from time to time, but the following will be found practicable :—

A is the steam-boiler, and B a tank some distance above; is fed by a pipe F, with a flap-valve opening into the tank as shown. This tank is also connected with the boiler by two pipes C D,

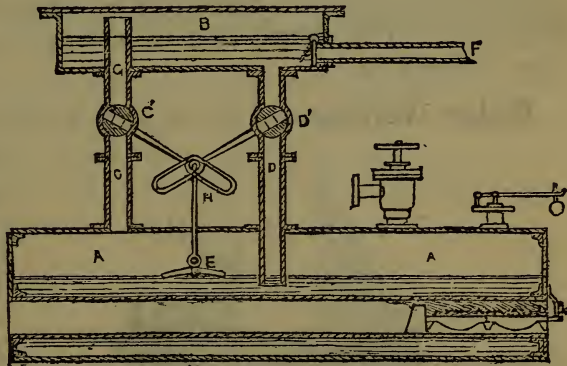

each of which is a cock C^1 D^1 connected by levers with slotted eyes to a pin, on the end of a rod of iron H; the other end of the rod is coupled to the float E inside the boiler.

The action is as follows :—Suppose the water in the boiler was to get low, then the float E would go down with it, bring down the slotted levers and open the cocks C^1 D^1 in the pipes C D, which would open two communications between the boiler A and the tank B; the pipe C letting steam into the tank and forcing the water down the pipe D till the water in the boiler regains its level when the float rises, shuts the two cocks, and

cuts off the communication with the tank, which then fills again through the pipe F. The flap-valve is to prevent the water returning down the pipe F.

Boiler Construction.—The fire tubes passing through the steam space of boiler would not heat the steam, but would condense it, in proof of which

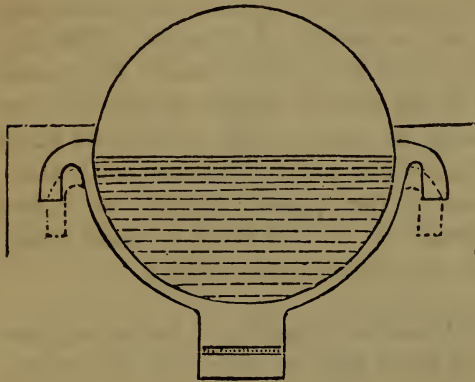

an egg-shaped boiler in work had the flues built 2 inches higher than the water-line, and was in consequence unable to keep up a constant supply of steam. But when the flues were lowered 2 inches below the water-line, a sufficient supply was kept up. The upper tube plate, though placed in a horizontal position, would not impede the rising of the steam. The dotted line in sketch shows where the flues were lowered to.

Boiler Working.—An old rule for Cornish, and 2-flued

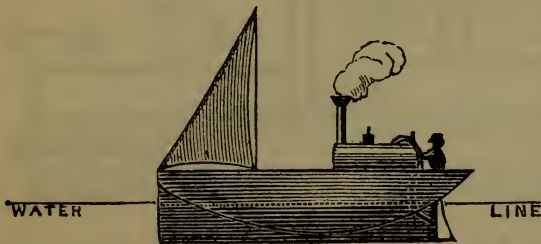

boilers, is to allow 5 square feet of water surface per horse-power of boiler; therefore we make the total boiler horse-power from $1\frac{1}{2}$ times to 2 times the nominal horse-power of engine

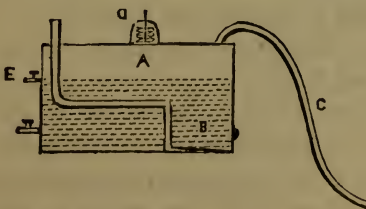

Steam-Propeller for Model Boats.—

Various contrivances have been adopted from time to time for propelling small boats. Mr W. G.

Kemp suggested the following :—A, boiler ; B, furnace ; C,

steam-pipes ; D, safety-valve ; E, guage tap. The steam-pipes should be made of indiarubber.

This, on examination and trial, proved to be a failure, as the steam condensed with propelling the boat ; but it was found that, if the end of the steam-pipe were brought to a point with a very small hole in it, and inserted into another pipe, so shaped as to leave a space all round the entrance of the point of the steam-pipe, the rush of the steam drew in with it a quantity of air, which it forced out of the stern of the boat, and consequently forced it through the water at a very fair speed. It answered better when the keel of the boat was made wide at the stern, and two thin pieces of metal were fastened on the side, so as to force the air direct astern, than when the pipe alone was brought through.

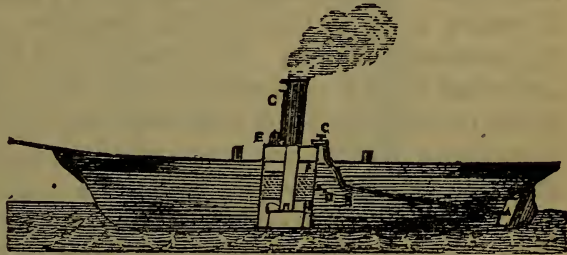

A, pieces of thin metal fastened each side of keel ; B, point of steam-pipe entered into the air-pipe ; C, steam tap ; D, D, water-level taps ; E, spring safety-valve ; G, pipe attached to valve to carry off waste steam ; F, water level ; H, spirit lamp.

Another method is described in the following diagram :—A, a hollow ball ; B, steam - pipe from boiler to ball ; C, pipe from ball through bottom of boat ; and D, pipe from ball through stern of boat. To the end of steam-pipe B is attached a nozzle, which projects within the ball fully past its centre, about in a line with the far side of pipe C, as shown by dotted lines at E. The force of the steam in rushing through the nozzle tends to form

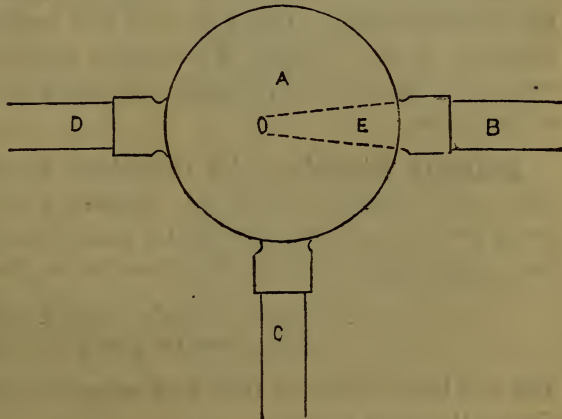

a vacuum within the ball ; immediately the water rushes up the pipe C, and, being caught by the steam, is forced through the pipe, and so keeps up a continuous stream.

The general principle of the screw-propeller may be thus described :—If a thread be wound upon a cylinder equal distances apart, it will trace a single-threaded screw ; if another thread be wound on the same cylinder between the first thread, they will trace a double-threaded screw. Now, if the threads be supposed to be raised into a very deep and thin spiral feather, and the cylinder be supposed to become very small, then a screw of the proper kind will be obtained for propelling vessels, except that only a small piece of such screw must be employed. A two-bladed propeller is a short piece of a double-threaded screw, a three-bladed propeller is a short piece of a triple-threaded screw. The diameter of the screw is the circle described by the extremities of the arms, the pitch is the distance in the line of the shaft from one convolution to the next. Sometimes screws are made with an increasing pitch in the direction of their length, also from centre to circumference. The original screw propellers were made with several convolutions, but are now reduced to about 1-6th of a convolution. The term length indicates what portion of a convolution is employed. If a screw of 9 ft. pitch has 1-6th of a convolution, the length will be 1 ft. 6 in. The slip of the screw is the difference between the actual speed of the vessel and the speed it should attain if the screw worked in a solid nut ; this is called the positive slip. There is also the negative slip, where the velocity of the vessel is actually greater than if the screw worked in a solid nut, though the latter is not of very frequent occurrence.

Railway Signals.—All travellers by railway are familiar with the ordinary mode of signalling by means of movable arms or semaphores and lights, and probably not a few of them are acquainted with the signalman's jingle—

“ White for right, red for wrong,
And green for gently go along ! ”

But the best system is that now adopted, first, we believe, on the South-Western system.

After the introduction of Mr Preece's plan of Block Signalling on the South-Western, these repeaters, which are similar in

construction to the block instruments, were fixed in one or two places for experiment, and the experiment was so successful, and their use so valuable, that they were gradually extended.

The great merit in these signal instruments is the assimilation of the indoor or block-signal to the outdoor, so that if a semaphore, disc, or other signal be used on the line to warn the engine-driver, the man who has that signal under his control is himself in the first place warned by a similar, but miniature, semaphore or disc inside his box, so that where it is necessary that a signal should be repeated and made visible to the signalman, the signal in his box is made similar in form, but in miniature, to the outdoor signal itself. Every motion, therefore, of the signal-lever would produce a corresponding result upon the small signal, enabling the signalman to see instantly whether all was right.

In fig. 1 will be seen a front view of a small semaphore; fig. 2 shows an elevation of the interior arrangements, both of them showing the semaphore arm down, giving the "All clear" signal. A is a strong horse-shoe electro-magnet fixed at the bottom of the box. B is the armature pivoted at G, and weighted at W by a small weight, which is made to slide up or down the armature lever between G and C. At the end of this lever, at C, is attached a long lever to the head of the semaphore arm.

FIG. 1.

FRONT VIEW.

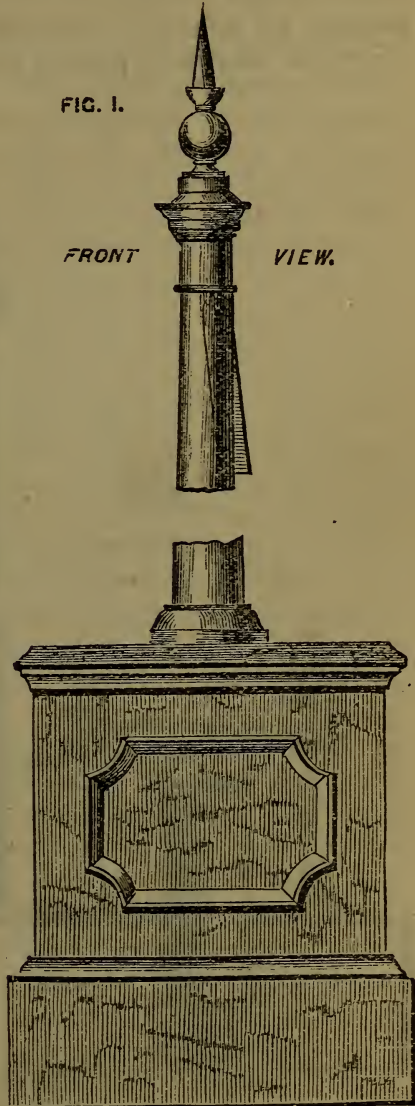

The armature has a limit to its movements by the stops at F and E.

It will be seen that any motion up or down of the armature must exercise an opposite motion of the long lever CD, and exercise an influence upon the arm to raise or depress it. A current of electricity passing through the electro-magnet would

at once exercise magnetic effect, and cause the armature to be attracted; this would have for effect the immediate raising of the semaphore arm, which would remain in that position so long as a current flowed round the magnet; immediately on the cessation of the current, the electro-magnet would cease its action, the armature would, by reason of the weight W, be restored to its original position, and the arm would fall and give the "All clear" signal, as in the diagram. It will be seen, therefore, that by the action and cessation of a current we can raise or depress a semaphore arm; and that if there be contrived

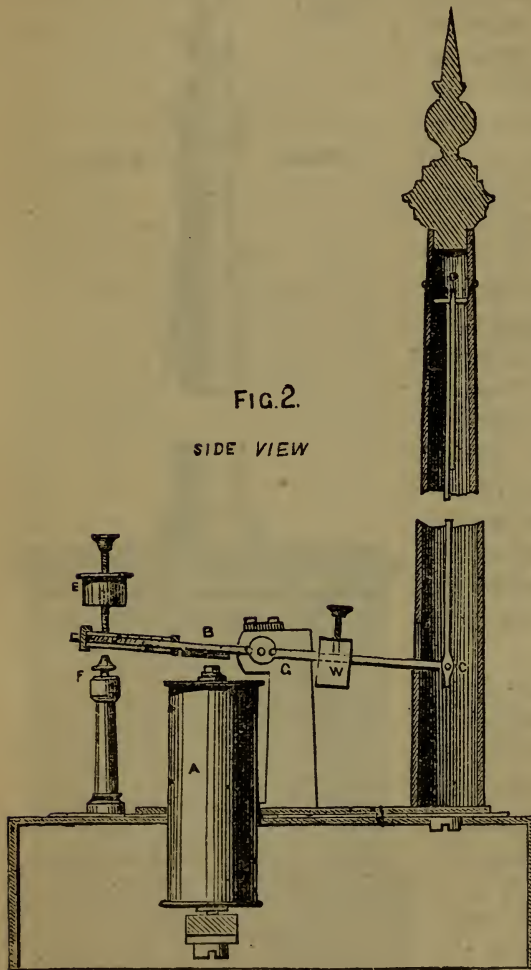

some automatic arrangement in connection with the outdoor signal to effect this object, we have at once a faithful repeater in the signalman's box of the outdoor signal, however distant it may be.

Such an arrangement as the following has been adopted. At the head of the semaphore, close to where the arm is pivoted, are fixed, one on each side, and insulated from each other, two springs, the one in connection with a live wire to the signalman's box, where it is attached to one end of the electro-magnet, the other spring is in direct communication with the earth. Upon the arm itself is fixed a piece of brass, so that when the arm is raised it presses up between the two springs and completes the circuit, but only when the arm is almost fully raised. In the signalman's hut is placed a battery, one pole of which is to earth, the other to the electro-magnet. The battery circuit is, therefore, through the electro-magnet, insulation taking place at the spring of the semaphore. In this position, therefore, the miniature semaphore is at "All clear" the same as the distant signal itself. Immediately the signalman moves his lever to alter the signal, the arm is raised, the brass piece on the arm completes the electric connection between the insulated spring and the earth spring, the battery is at once brought into play, the magnet acts, the armature is attracted, and the small semaphore arm is raised to "Danger," corresponding with the outdoor signal. The whole of this takes place in a far shorter time than it has taken us to describe. The action is almost immediate; so long, therefore, as the arm is raised to the position of "Danger," the miniature arm faithfully reflects that position; but as soon as the lever is restored to its original position, the distant signal is lowered, the circuit is broken, and the armature is at once released, the small arm therefore falls, and shows the state of the distant signal. Should the miniature arm remain down when the signalman puts his lever over, he is at once aware that his wire or part of the signal apparatus is out of order, and would consequently take immediate steps to put it right.

In order that the battery may not be wasted, it is arranged that the signal which is used less than the other should attract the armature: thus at a junction the "Danger" signal is constantly in use, the "All clear" only to admit a train. At a station the distant signal is generally at "All clear." So in the one case we want the armature when attracted to lower the arm, and in the other to raise it. By referring to the sketch, the attraction of the armature will in this case raise the arm; but if the lever on the arm be fixed in front instead of behind

the pivot D, the attraction will raise it, and *vice versa*. When it is necessary that the "All clear" signal or the lowering of the arm should bring the battery into play, then the insulated springs must be placed at the back of the semaphore, and the brass connecting-piece at the back of the arm. When so placed, no current is passing when the arm is raised; the repeater, by gravity, has its arm up; but when the signal-arm is lowered, it makes connection, the electro-magnet is brought into play, and the small arm is lowered.

As semaphores are now being generally adopted everywhere, we have described the arrangement adopted, but on various

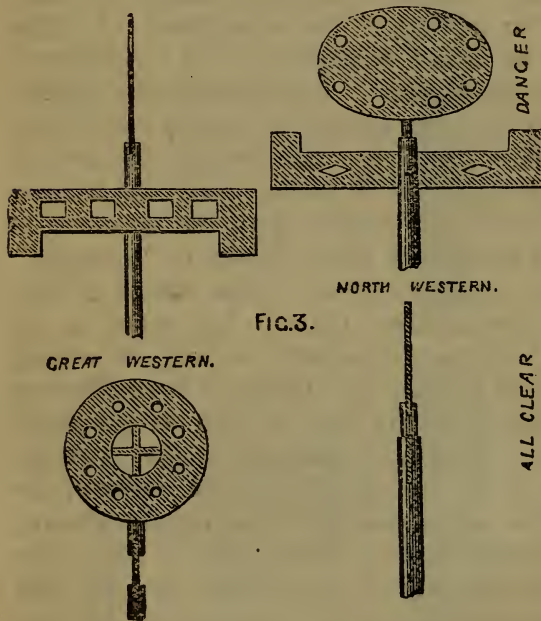

lines there are different signals in action to which these repeaters are equally applicable. On the South-Western the disc, on the Great Western and North-Western the disc and bar, as the following sketches, 3 and 4, show. Instead of an up-and-down motion, these signals are altered by a circular movement. In fig. 4 is a miniature "disc," the interior arrangement of the electro-magnet is

similar, but at the end of the armature is placed a rack which works into a pinion fixed on the rod that carries the disc. The attraction and release of the armature conveys a circular motion to the rod; the disc is consequently moved from the one position denoting "Danger" to the other denoting "All clear." As the motion of the disc outdoor is different to that of the semaphore, the connection necessary to put the live wire to earth is consequently different.

Upon the wooden upright that carries the disc-rod is placed a piece of brass, fitted with a spring to ensure contact; this is

properly connected, and is protected from wet by an iron roof. Upon the rod which is in connection with the earth is fixed a second piece of brass with a spring; this is fixed at the same height, and is so connected that when the disc is turned these springs make a good rubbing contact.

The action is of course similar to that of the semaphore: immediately the lever is pulled, the disc turns round and the springs make connection, the armature of the miniature disc is attracted, and by the rack-and-pinion movement the disc is turned into a position corresponding with the outdoor signal. When the disc is turned the opposite way, or to "All clear," contact is broken, the weighted armature falls back, and "All clear" is shown in the signalman's hut. The contact arrangement on the outdoor signal is similar to what would be applied to signals such as are used on the Great Western. To make the miniature signal agree, it is only necessary to fix, instead of the disc, a disc and bar, as in fig. 3.

Many of the discs and semaphore repeaters have been fixed on the South-Western and other lines for some years; they give great satisfaction, and continue to work well. In places where, during fine weather, the signal is visible, yet in consequence of the place being situated low, and being liable to fog, there are very many days in the year when the signal is invisible. In such places some extra precaution of this nature should be taken.

Electric Railway Signal.—The object of this new apparatus is to prevent the possibility of a signalman signalling that the line is clear until the train which should control his move-

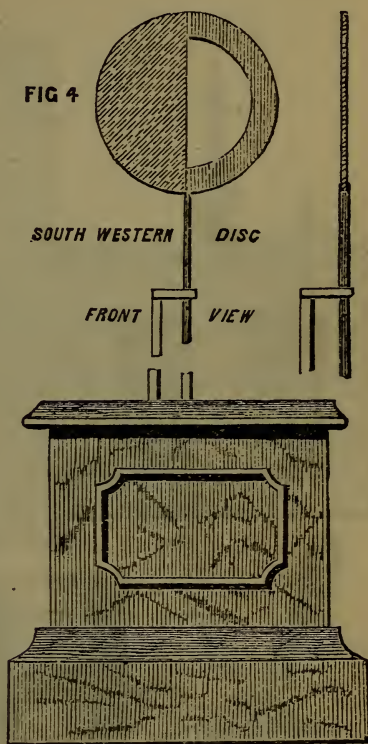

ments has actually passed his box. There is applied to the switch or lever of the railway-signal telegraph apparatus a means of locking the handle or lever after it has been used to adjust a signal, and of retaining it in a fixed position until released by the action of a passing train, which will remove the cause for retaining, say, the danger-signal in a fixed position.

Fig. 1 is a back view of the apparatus, fig. 2 an inverted plan view, and fig. 3 a vertical section taken in the line 1, 2,

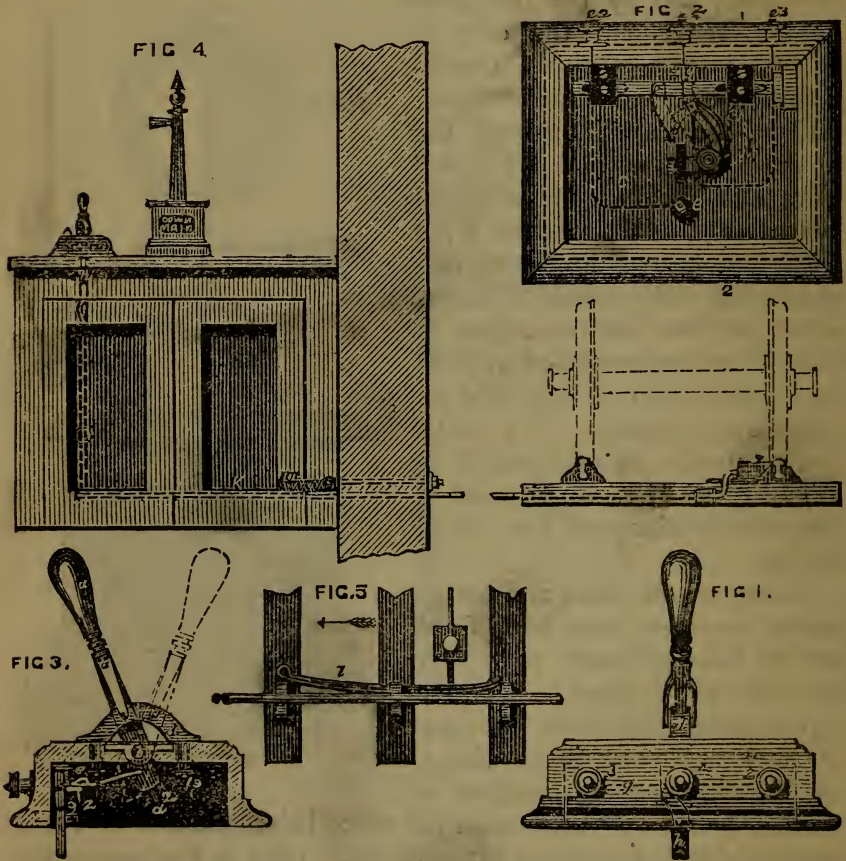

of fig. 2. The switch-lever apparatus is connected (as shown at A, fig. 4) with the railway by an arrangement of levers and rods, which are set in action by the passing train for the purpose of withdrawing a restraining bolt applied to the handle or lever of the switch apparatus, and thereby leaving it free to be set in action by the signalman.

a is the handle or lever of the switch apparatus mounted on a centre at b , the bearing for which is insulated by being let into a table of wood c . Fitted to opposite sides of the switch handle are the spring-clips $a^1 a^2$, which are intended to embrace the divided bridge or insulated segment-plates $d d^3$, connected by clamping nuts $e e^3$, to electric wires leading to the terminus $e^1 e^3$. The switch-lever is also in metallic contact with a wire leading to the terminal e^4 . A pin a^1 at the lower end of the switch-lever a projects into the forked end of a bell-crank lever f , mounted on the under side of the table, and fitted at its opposite end with a spring catch or tumber f^1 . As this switch-lever a is moved it will give a rocking motion to the bell-crank lever, for the purpose to be presently explained. The lower part of the switch-lever has a notch cut in its edge to receive a sliding bolt g , by which it is locked in its normal position. This bolt is carried by a slotted guide-bar g^1 through the slots of which screws are passed for securing it to brackets attached to the under side of the table. This guide-bar is provided on its face with a pin g^1 , against which the spring-catch f^1 is intended to strike in one direction of its motion, for the purpose of driving that bar forward, but on its return motion the spring-catch slides over the pin. Upon the edge of the guide-bar is a second pin or projection g^3 , through which the bar receives an endway motion in the opposite direction to that imparted by the bell-crank. This pin g^3 is acted upon by a pendant-lever h , which is itself acted upon by a vertical rock-lever i , fig. 4, connected at its lower end to a sliding-rod k ; this rod k is caused to bear against a horizontal-lever or switch l , applied to the railway track, as shown at fig. 4; and in plan view at fig. 5, a spring m , or a weight, being used to keep the rod up to its bearing. Supposing now a train to be passing along a line fitted with the locking apparatus above described in the direction of the arrow, fig. 5, the switch or lever l will, by the lateral pressure it will receive from the flange-wheels passing between it and the fixed rail, be rocked, and it will thus give an endway motion to the rod or tracker k , which will in its turn rock the levers i and h , and the latter, striking against the pin on the bar g^1 , will drive it and the bolt which it carries into the dotted position of fig. 2. The switch-lever will, therefore, be free to be moved from the drawn to the dotted position of fig. 3, for the purpose of operating a distant signal.

As this apparatus is specially adapted for use with Mr Preece's block-signal telegraph apparatus, in which the semaphore arm is maintained by a weight and depressed by the action of the electric current, it is used in the following manner, viz. :—The terminal e^2 is connected with the earth, the terminal e^3 with the battery, and the terminal e^4 with the line wire. When, therefore, the hand-lever is in the drawn position of fig. 3, which is its normal position, there is no current passing through the distant signal apparatus which the switch apparatus is intended to control, and the block-signal is consequently up; on the other hand, when the hand-lever is in the dotted position, the current will pass through the distant signal apparatus, and retain the semaphore arm at the depressed position, thereby indicating "line open." If now the signalman at the distant station A signals to the man at station B, that a train has started from A in the direction of station B, the duty of the receiver of this signal will be immediately to raise the block-signal at station A; this he will do by throwing over the switch-lever B into the drawn position; but in the act of doing this he will cause the bell-crank lever f to strike the pin g^2 on the sliding-bar g^1 , and throw the bolt g into the notch of the switch-lever; the lever will therefore remain fixed, and be beyond the control of the signalman at station B. As soon, however, as the advancing train passes the switch or lever l , and sets the rod k and lever i h in motion, as above explained, the guide-bar g^1 and bolt g will be returned to the dotted position of fig. 2, and the signalman will then be able to set his switch apparatus in action. If, however, he should delay in communicating the proper signal to station A that the line is open, no casualty can arise, the only inconvenience being the undue blocking of the line.

This apparatus is in practical operation on the London and South-Western Railway, and is spoken of very highly.

Fog Signals.—The following plan, if capable of being reduced to practice, would displace the explosive fog signals now in use. It also acts as a distant signal. The original part of the proposal is the adaptation of the bell-crank lever H, so as to strike a bell F in a passing train by means of a lever G, or similar contrivance placed outside the guard's van and engine. It will be seen by looking at the dotted lines that

when the semaphore L is down, the lever B is lowered, and causes H to fall below the level of the lever G, attached to the train. Therefore, only when the semaphore is at danger is the bell struck to warn the guard and driver. The lever H is put so far down the line as to enable the driver to stop the train on arriving at the semaphore post.

A, signal-post ;
 B, lever, with weight ; C, wheel at the signal-box or station ; D, railway line ; E, hammer ; F, bell ; G, lever, with weight ; H, bell-crank lever ; I, chain to connect H with B ; K, chain to connect C with B ; L, semaphore.

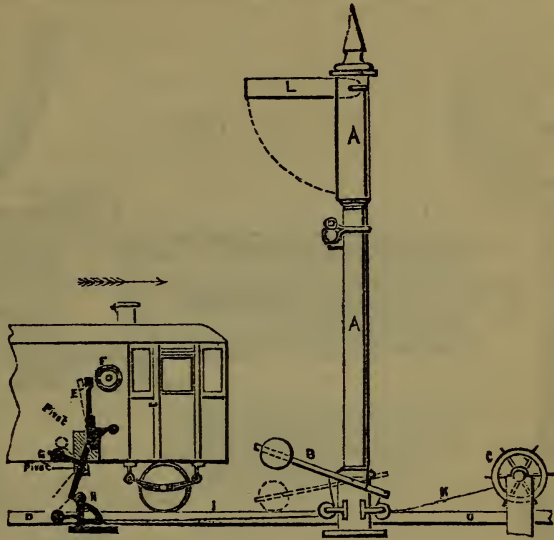

Self-Acting Railway Signals.—1. Below is a self-acting signal, said to possess advantages over previously-invented plans of self-acting signalling. Fig. 1 is an elevation ; fig. 2 a plan. The same figures refer to both drawings.

On the train passing the post, A strikes the lever B, and causes the signal C, which is provided with a lamp for night signals, to turn to danger, the lever B on being struck causes the wire or rod D to move in a forward position, so that when the

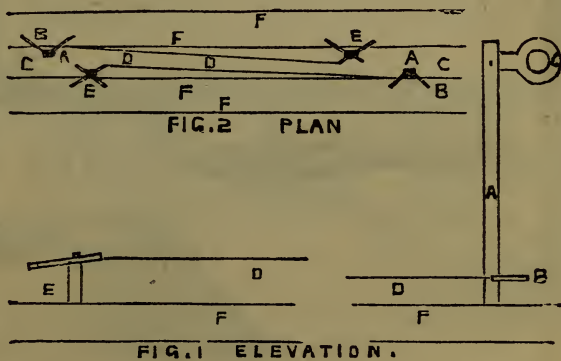

train reaches the lever E the signal is put to "All right." F are the rails.

2. The next self-acting apparatus we shall describe is intended to be fixed on the side of the permanent way.

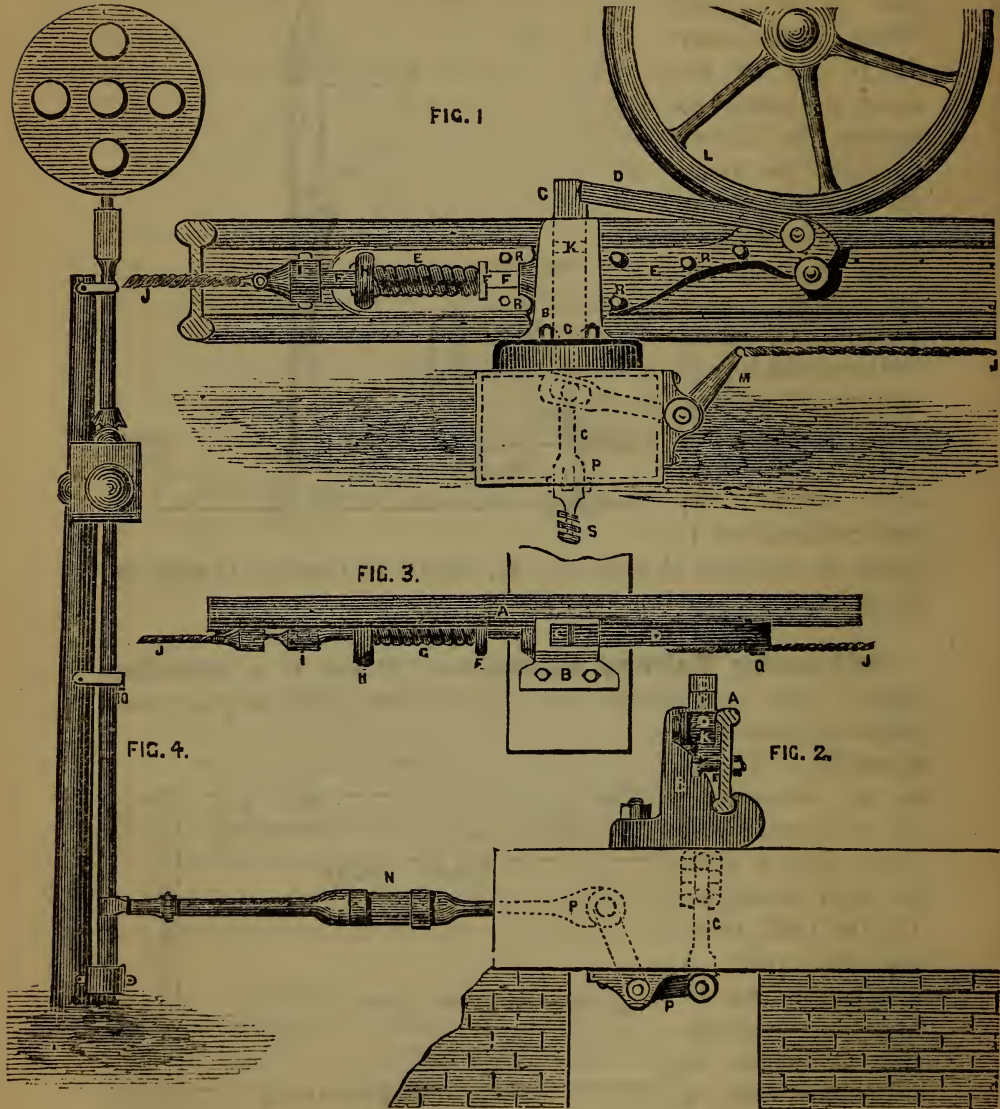

Fig. 1 is a front view, showing all ready for the first wheel of the engine or carriage to press it down on the lever D. Fig. 2 is an end view, showing other working parts of the appa-

ratus, with the signal, fig. 4, attached to the lever P. Fig. 3 is a top view.

Suppose a train coming up to where a signal is placed. The wheel L in fig. 1 comes on the lever D, passing down which is a slide-bar, having a square or round hole K in the middle, a little lower down a cross-pin or the eye-lever, and at the bottom a joint for lever P. At S is a powerful spring to lift up the slide-bar C. When C is brought down, peg F is forced by the spring G under the hole K, and working the lever P brings the signal up for the next train. N is a strong elastic, fitted to take the sudden jerk which the engine would make. H is the eye-bolt for the peg to work in, I is to fasten wire, and J to plug or peg F. Suppose the train has passed over the lever D, down goes the bar C, in goes the peg F to the hole K, which is a great deal larger. The first signal is up, and now we come to the second, just similar to fig. 1; the wire JJ is attached to the wire J in the first one, and by passing over the second one works the lever M, withdraws plug F, and by the action of the powerful spring at the bottom, up comes the bar C on lever D, and down goes the signals, the one that we commenced with reacting for the next train to come to the second signal; and the signalman can tell whether the first train has passed over the third apparatus by seeing whether the signal is down or not. The latter train cannot run into the other unless the signals are neglected. [There is considerable ingenuity in this idea.]

Railway Brakes.—The following is perhaps more suited for goods than for passenger trains. It should be fixed on both sides of every truck of the train.

a is the cill of the truck, *bb* the irons connected with the wheels, *c* the rail to tie in the wheels, *d* is a

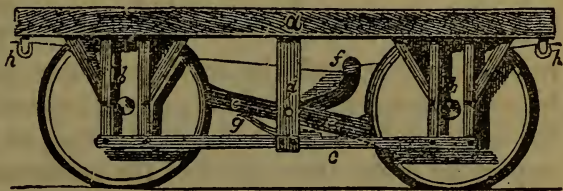

stud on the brake of which *ec* swings, *f* is a lever in the centre of the truck, *g* is a spring to keep off the brake. In case of danger, the driver would tighten the wire-rope *hh*. This would raise the lever *f*, which would bring the ends of the brakes in contact with the rim of the wheels. These would lay hold of

the brake, and force it on so tightly that the wheels must skid. [This idea has not, we believe, been investigated with any practical result.]

Communication between Passenger and Guard.—Among the suggested means of arresting the attention of railway guards by passengers in the carriages, the following crude ideas have some claim to attention :—

1. This consists of a circular tube, which is fastened in the interior of the panel which divides the compartments to the side of the carriage.

AA is the side of the carriage ; B is a metal tube fastened to its inside, a spiral steel spring is contained in this tube, and fastened to a rod I. This rod has a metal plate D on one end,

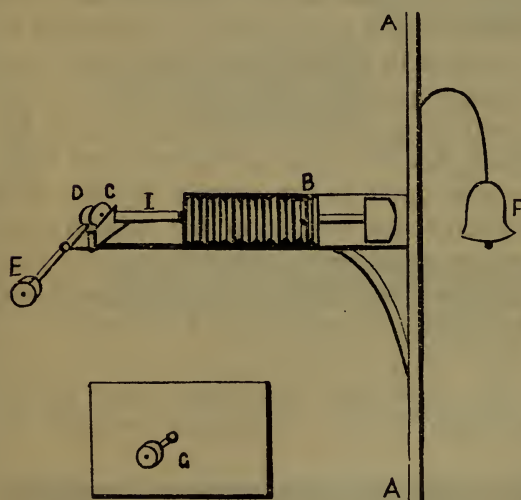

which secures it at C, and holds the spring back. On the other end of the rod a hammer head is fixed. When the knob E is pressed, it shoves the plate D from its place, when the force of the spring will send forward the hammer, which, striking on the bell F, placed on the outside of the carriage, would attract the attention of the guard. The hammer would

remain outside, and the carriage where assistance was wanted be seen immediately. If any passenger used this “ facetiously,” the trick could at once be discovered, as the only part of the apparatus under the control of the passenger is the knob on the outside of the panel, as shown at G, and the spring could not be placed in its former position except by opening a small door in the panel, which would be kept locked.

2. In the following plan, there would be the necessity of the guard’s van being higher than the other carriages. There are other evident objections to the details.

By pulling the handle B you not only ring the bell, but also raise the alarm signal C to the position shown by the dotted lines. In the alarm signal there is a

piece of red glass, on which is painted the number of the carriage, which, when raised, exactly fits on the face of the lamp

D, thus showing a red light. By this means the guard would be enabled to discover, either by day or night, the carriage from which the signal is made.

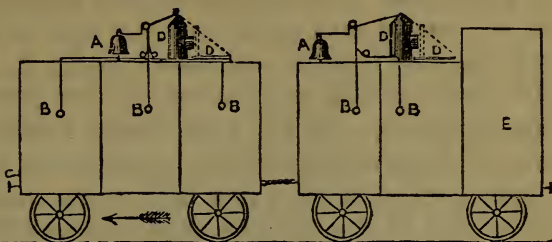

3. Let every carriage have a loud bell attached, with a rope and handle, or chain and handle from every compartment, so that the pulling of the handle would cause the bell to ring, and so attract the guard's notice. Let the guard's van be built a little higher than the other carriages, so that he could always have a full view of the train, and see when all was right.

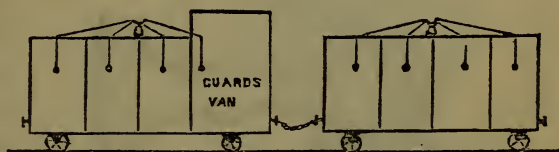

4. In this scheme the bells are done away with, and explosive signals substituted.

Fig. 1 is the side view, AAAA are four common railway fog signals; each one is coated, and made perfectly air-tight (glass would answer the purpose best), so as to protect the powder from injury and moisture. These signals are

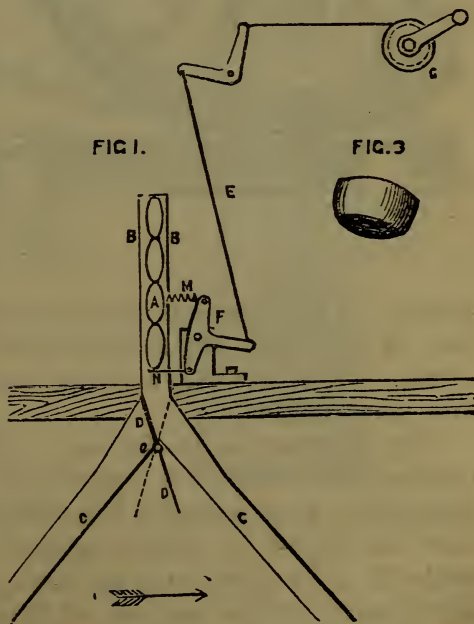

FIG. 1.

FIG. 3.



These signals are

shaped as shown in fig. 3, and made about the size of a small oyster. BB represent the sides of box in which the signals A are enclosed. CC are two square spouts or channels, leading down, one to each wheel—on the side of the carriage, on which the machine is fixed—as shown in fig. 2. These channels are just large enough to admit of the free passage through them of the signals A. DD is a self-acting guide, placed at the junction of the two channels CC, and works on its hinge B. The upper portion of the guide DD is just weighty enough to cause it to rest in the position seen in the sketch, or in that of the dotted line.

The lower part of the guide is a light square board hanging beneath the flooring of the carriage, and is acted upon by the rush of air when the train is in motion. Thus it will be seen that the channel on the right or left hand side will be opened as the direction of the train may require. F consists of a lever, slide and spring, the working of which will shortly be explained. E is a wire, and may be connected with ordinary bell handles in each compartment or to each seat if thought

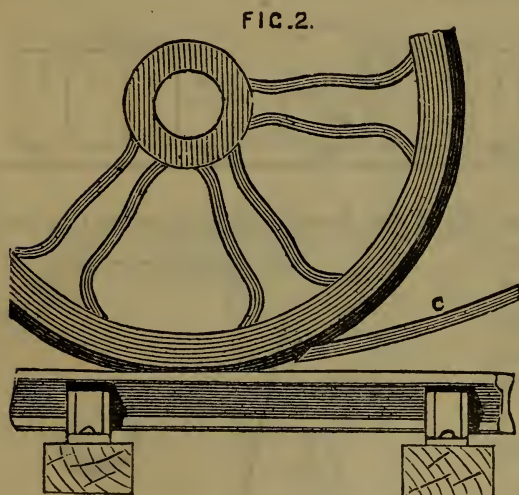

proper. The apparatus may be placed under the seat, or any part of the floor, but is best about midway between the two wheels. The box BB and the channels CC may be made of thin sheet metal.

The working is as follows:—The bell handle G being touched, the lever F is operated upon;—the small slide N is withdrawn, thus releasing the bottom signal A, at the same time the spring M presses against the second signal A, and holds it in its place until the slide returns, when the second signal takes up the position of the first. The first signal A being now at liberty, passes down the left-hand channel C, and

is delivered under the wheel, fig. 2, which runs over it and causes it to explode. This, as in the case of an ordinary fog signal, is accompanied by a loud report, which would call the attention of the guard and the whole train. In the foregoing description the train is supposed to be proceeding in the direction of the arrow in fig. 1. Should the train be going the opposite way, the guide DD would be reversed by the pressure of the current of air on the lower part of it, and would then lie in the position of the dotted line, thus opening the channel C on the right-hand side, down which the signal A would slide, and be delivered between the wheel and the rail as before described. The alarm may be repeated as long as there are any signals A in the box, which may be constructed to contain any number.

One advantage to be claimed for this scheme is that no connection between one carriage and another, along the whole length of the train, is necessary to effect a communication with the guard.

5. The following plan suggests oral communication between passengers and guard. It is proposed to place beneath the floor of each carriage a metal speaking-tube, connected between the carriages by a continuation of indiarubber tubing, coupled as shown in the annexed drawing, forming a line of communication between the guard and driver at either end of the train. The pipe to be supplied at each end with an alarm whistle.

Each compartment of the carriages should be furnished with an intercommunicator, which would enable the passengers to communicate with the guard or driver through the same pipe. Across the mouthpiece in each carriage it is also proposed to

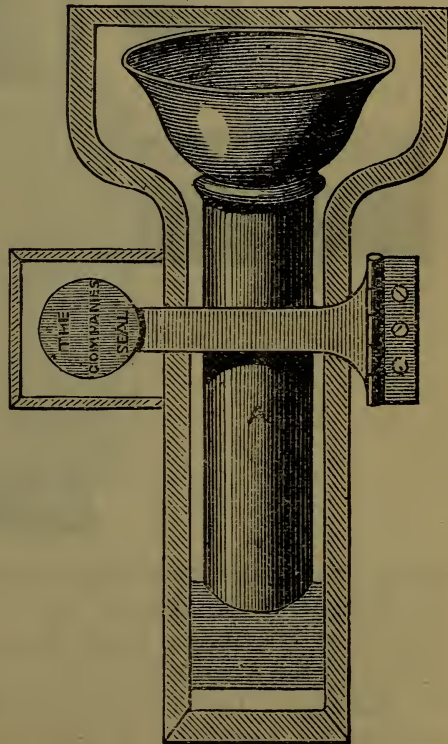

place a small clasp, secured by a seal (that must be broken before the apparatus can be used), which, by being the means of detection of, is therefore a security against, improper use.

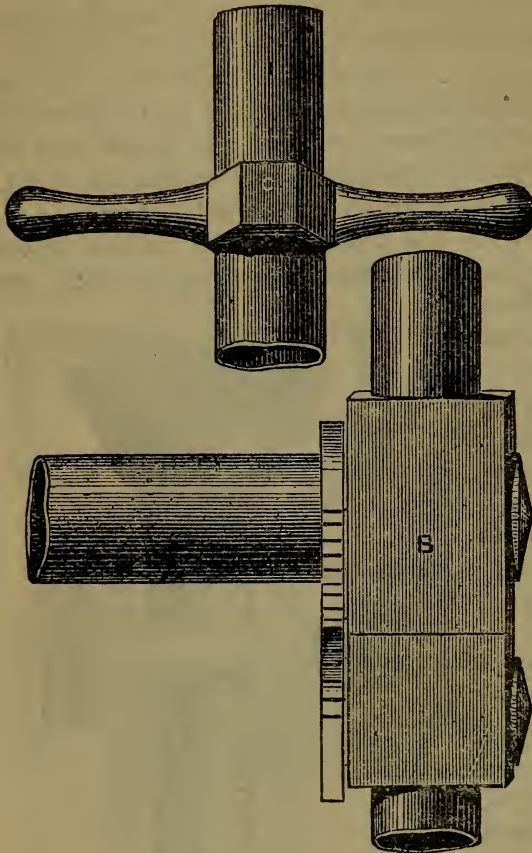

A, communicator, as seen in the carriage; B, intercommunicator under the floor of ditto; C, screw coupler between the carriages.

To communicate, break the seal, pull out the pipe as far as it will come, and hold it so till your communication is complete, tell the guard the number of the carriage, then let the pipe return to its place by the action of the spring.

Tramway Locomotives. — The introduction of the tramway in the London streets will eventually, we have no doubt, lead to the

employment of the locomotive instead of horses. Messrs Aveling & Porter have adapted one of the road locomotives for a tramway at Mr Gray's Chalk Works, Essex, for the purpose of hauling up the excavated chalk to the docks. This engine we now describe. On the top of the boiler, easily accessible, is arranged the gearing. A pinion on the crank-shaft gears into a spur-wheel on a second shaft, from which motion is transmitted to the driving-wheels, four in number, by an endless chain. The engine is of ten-horse nominal; cylinder, 10 in. diameter, 12-in. stroke; grate surface in fire-box, $7\frac{1}{2}$ square feet; number of tubes in boiler 60, each $2\frac{1}{4}$ in. external diameter. There are two feed-water tanks, one under the coal

tender, and the other under the front part of the boiler, holding collectively 350 gallons. The wheels are 4 feet diameter, with short tyres, coupled, as shown, with an endless chain, which can be tightened by an apparatus consisting of a slot in the main bracket, in which the bearings of the shaft can be raised and lowered. The cylinder is jacketed, steam being carried around it to the valve-chest. The boiler is fed by a pump worked by an eccentric on the crank-shaft. The fuel is carried in a coal-bunker formed on the foot-plate behind the fire-box, sufficient space being provided to accommodate from 10 cwt. to 20 cwt. of coal, according to the mode of packing. At Gray's the line leading from the quarries to the wharves is about a mile in length, and is laid to the 4-ft. $8\frac{1}{2}$ -in. gauge. At the quarries it divides into two branches, one having an incline of 1 in 36 to 1 in 41 against the traffic, the incline being, moreover, situated where the line makes a series of reverse curves. The other branch has a steep incline where it leaves the pit. On the former branch the load of the engine consists of 15 waggons, weighing about $1\frac{1}{4}$ tons each, and each containing $1\frac{3}{4}$ tons of chalk, the total load being thus 45 tons, in addition to the weight of the engine. But the engine can take 20 loaded waggons up the bank, and a still heavier load has been hauled. On the latter branch the load of the engine consists of 15 waggons, weighing $1\frac{1}{2}$ tons each, and each loaded with $2\frac{1}{4}$ tons of chalk. Thus the load, exclusive of engine, is $56\frac{1}{4}$ tons. As to economy, we learn that during one week the 2 engines formerly employed conveyed 3138 tons of material from the quarries to the wharves, with a consumption of $141\frac{1}{2}$ cwt. of coal, the fuel consumed being thus equal to 5 lbs. per ton drawn. On the other hand, two of Messrs Aveling & Porter's engines transported during corresponding week 5100 tons of material, with a consumption of 125 cwt. of coal, the expenditure of fuel being in this case equal to about $2\frac{3}{4}$ lbs. of coal per ton hauled. It is estimated that this difference in the quantity of coal required to perform a given work will save the company upwards of £260 per annum. Altogether, these engines have given abundant evidence of being well adapted for use in quarries, and wherever heavy loads have to be moved at slow speeds—doing the work at about half the cost of horse-power. The engines can also be employed to drive portable or fixed machinery. All the wheels being coupled, the whole weight is available for producing adhesion to the rails, which is sufficient for the requirements of such lines.

Wheel Grease.—Nothing is equal to tallow for large cog-wheels ; but a good grease may be made of tallow 25 pounds, tar 25 pounds, soda 15 pounds, and water 3 or 4 gallons. Boil the soda and water till the former is dissolved, then add the other ingredients, and boil till thoroughly mixed.

Rifle Stadia for Judging Distances.—An apparatus of the kind, for rifle practice, patented by Mr D. M'Callum, has been approved and extensively used in some districts.

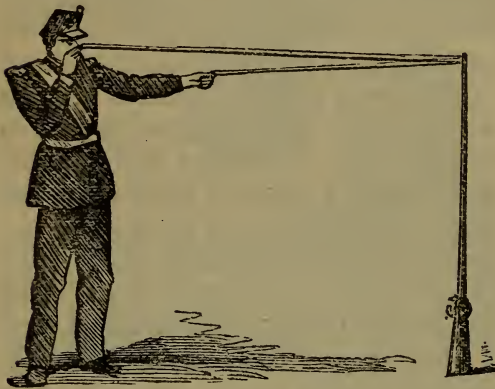

900 yards.

1. Place the butt of the rifle on the ground, with the toe of it towards the right.

2. Then place the piece of metal in muzzle with end marked 'Foot' upwards, if the distance of a man be required.

3. If the distance of a man on horseback be required, place the end marked 'Horse' upwards.

4. Steady rifle with left hand, and with the finger and thumb of the other hold the tape closely to the *eye on the cheek-bone*.



100 yards.

5. Then look at the object through the aperture, and *slide the face along the tape until the eye definitely and completely covers the feet of the man and the top of his cap, or the hoof of the horse and the cap of its rider.*

6. Now observe the mark on the tape where the finger is, and it will show the number of yards distant. Thus : Should the finger appear at the first subdivision beyond 100, the distance would be 110 ; if at the second subdivision, it would be 120 yards, &c.

7. Should the object be more than 350 yards off, it will be necessary to screw the ramrod in the centre of the piece of metal, and steady the rifle with the ramrod by holding it securely and keeping the tape at its full tension ; then proceed as before.

Gun Cotton.—The following is stated to be the best and simplest process for making gun cotton. Saturate some cotton wool in a solution of equal volumes of the strongest oil of vitriol and nitric acid for a few minutes, then express the superabundant liquid out of the cotton, and wash it in cold water until all taste of acidity has gone; lastly, dry at a gentle heat, about 120° or 130° .

Force of Gunpowder.—When gunpowder is heated nearly up to the point of decomposition, previously to ignition, the force of its explosion is greatly increased. It is stated that a temperature of 160° Fahr. increases the force of the explosion 1-5th, while a temperature of 400° nearly doubles it. This may in some measure account for the fact that highly-heated guns are liable to burst if the charge has been allowed to remain in the chamber a sufficient time before firing.

Gun Barrels.—*To Bore.*—Take a piece of rod, cast steel, $\frac{1}{8}$ in. smaller than the interior of the barrel and a few inches longer, beat one end up something larger than the size of bore, then turn or file it the shape of an egg, leaving the swell or centring part 1-20th of an inch larger than the bore. With a saw-file, cut longitudinal cuts $\frac{1}{8}$ in. apart, laying them the same angle as a rose-bit countersink, taking care not to injure the periphery of the tool; harden, and temper to straw colour.

Staining.—Spirits of wine 1 oz., tincture of steel 1 oz., muriate of mercury $\frac{1}{4}$ oz., nitric acid $\frac{1}{4}$ oz., and water 1 quart. The above mixture must be well incorporated before use.

Process.—1. The grease to be removed by coating the gun with lime, put on in a thin paste, and allowed to dry, then brushed off with a clean hard brush. 2. The mixture to be laid evenly on the gun with a sponge, and allowed to stand till dry. This operation to be repeated as frequently as the gun dries, for the first ten hours, then the rust to be thoroughly scratched off with wire cord. 3. Coat with mixture, and let it stand till dry; if the gun rusts freely, no more mixture need be applied, but that already applied may be scratched off with wire cord at the end of ten hours if dry; but if it should rust slowly, then one or two extra coatings of the mixture may be laid within the ten hours, taking care that the old rust is dry before again applying the mixture. 4. As soon as the barrel is dark enough, it must be immersed in boiling water to kill

the acid, and then oiled with olive oil while warm; then remove the oil with turpentine, and varnish with copal varnish.

Browning.—Equal parts of butter of antimony and olive oil to be rubbed on while the barrel is hot, expose to the air till sufficiently brown, clean carefully, and coat with a thin shellac varnish. Butter of antimony is a powerfully corrosive poison, and must therefore be handled with care.

Colouring.—First clean the barrel perfectly, but do not touch it with the hands. To avoid this, put a stick or plug into the end of the barrel to hold it with, then apply the following mixture with a rag (not too much at a time, if a twisted barrel, as you will not be able to get the twist to show properly). After the colour-matter gets dry, it must be rubbed off with a steel-wire brush. For a plain barrel— $\frac{1}{2}$ oz. nitric acid, $\frac{1}{2}$ oz. spirits of nitre, 2 oz. sulphate of copper, 1 oz. tincture of steel, 8 gills of water. For a twisted barrel— $\frac{1}{2}$ oz. spirits of nitre, $\frac{1}{4}$ oz. tincture of steel, $\frac{1}{2}$ oz. sulphate of copper, 15 grains of mercury, $\frac{1}{2}$ pint of water. After having stained the barrel apply the following polish:—2 oz. spirits of wine, $\frac{1}{4}$ oz. gum Benjamin. Put it on with a soft rag or camel-hair brush: use it quickly, or it will dry very fast.

The Verge Escapement.—Every one who wears a watch should know something of its mechanism. He would then be better enabled to take care of it, and set it right when it went wrong. There are three kinds of escapements used in modern watches—the Verge, the Horizontal, and the Lever. The first is the oldest, and in some few respects the best. The parts of a verge are the cock and foot pallets, also cock and foot pivots, and the “collet,” or piece of brass soldered on to the top, and to which the balance is riveted. The parts of a pinion are the leaves or head, the arbor, and the pivots or bearings. The parts of a wheel are the teeth, the rim, and the cross; if the wheel is not riveted on to the head of a pinion, a “collet” is driven on to the arbor, and to which the wheel is riveted. The escapement is the term used to illustrate the action of the pallets in connection with the last or scape wheel, one tooth of which escapes at each vibration of the balance. The crown-wheel or verge escapement was the first invented. Fig. 1 shows how it is arranged in a watch. B is the balance, the axis of which is the verge; P¹ is the cock pallet, and P is the

foot pallet ; the top or cock pivot runs in the cock C, and the bottom or foot pivot in the potance X. S is the hair-spring and stud. The scape-wheel O, also called the balance-wheel, is riveted on to the head of the pinion ; the pivot inside the wheel runs in a dovetail fitted into the nose of the potance at N, this dovetail is made to slide in and out, so as to get the hole opposite the body of the verge, or the escapement equal ; the pivot at the other end of the pinion runs in a hole in the follower F, which is fitted into the counter - potance. The contrate-wheel W is not riveted on the pinion, but has a "collet" on the arbor to enable it to work into the scape-pinion. The

FIG. 1.

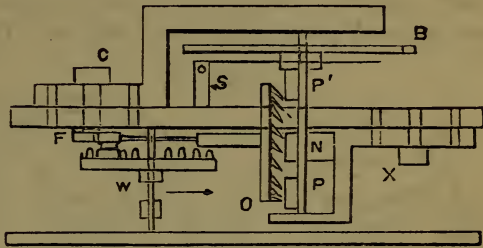

teeth and rim are contrary to those of other wheels, whence it takes its name. Fig. 2 shows the details. X is the potance ; T is the counter-potance, which is riveted into the top plate, and into the hole of which the follower F is fitted ; V is the verge with the "collet" turned down to fit the balance ; Z is the hair-spring "collet;" B is the balance ; S is the hair-spring stud, the outer coil of the hair-spring is pinned into the stud, and the inner coil is pinned into the "collet," which fits spring-tight on to the verge collet and close up to the balance, and can be set to any place by turning it round on the verge with a

FIG. 2.

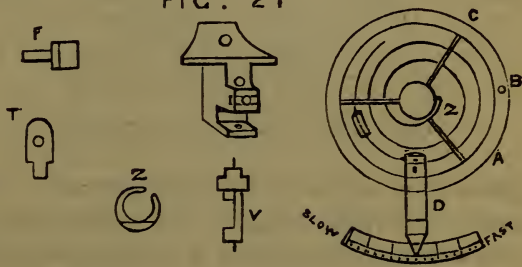

screw-driver put into the notch ; D is the regulator, fitted into a slide so that it can move in a circle having the verge as a centre, the end of the regulator projects under the outer coil of the spring, and has two small pins rising up from it, and between which the spring plays. The effective length of the spring can thus be altered by moving the index to *fast* if the

watch loses, and to *slow* if it gains. If the regulator is at fast or slow, and the watch continues to gain or lose, the spring must be altered from the stud, that is, more spring let out if gaining, and if losing more spring taken up. To do this, put a bristle into the cross of the contrate-wheel to prevent it running down; then take off the cock C (Fig. 1) and unpin the spring out of the stud with a pair of tweezers, take out the verge and turn the collet round with a screw-driver in the direction to bring more or less spring through the stud as the case requires; having done this, replace the verge, join in the spring, and put on the cock again. Then try if the watch is in

FIG. 3

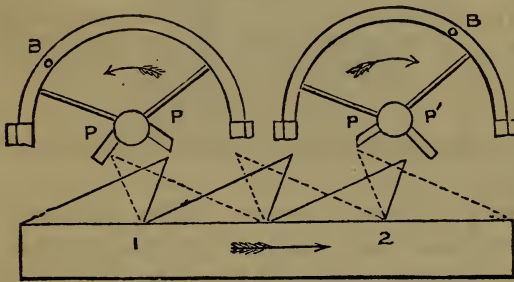
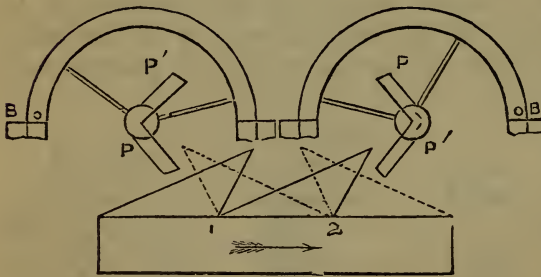

FIG. 4



beat; thus, supposing the balance is at rest and the banking pin at B, if the contrate-wheel is pushed round slowly and steadily with the thumb, the pin will be drawn first to A and then to C if the watch is in beat; if it is not, the "draw" will be more to one side than the other; if C has most draw the spring must be let out a little, and if A has most the spring must be taken up a little.

We must now explain the action of the escapement. The verge pallets are nearly at right angles; the scape-wheel has always an odd number of teeth, so that a tooth on one side is opposite a space on the other, and when one pallet is in action the other is out of action. Fig. 3 is a sketch of two escapements, the teeth of the wheel and the pallets are enlarged. The wheel must be supposed to be turning on its axis with the teeth 1 and 2, and the cock-pallets P' P' at the top, and the dotted teeth and the foot-pallets P P at the bottom. Tooth 1 has just escaped from and given impulse to the pallet P', and the dotted tooth has

dropped on to the pallet P, the balance B is "vibrating" or turning in the direction of the arrow, and will continue to do so until the impulse is exhausted by the bending up of the hair-spring and the "recoil" or backward movement of the wheel produced by the dotted tooth opposing the pallet P; the balance will now be brought back by the tension of the hair-spring; the dotted tooth will then give impulse to and escape from pallet P, the next tooth dropping on to pallet P¹, as shown by tooth 2; the balance B¹ is vibrating in the direction of the arrow, tooth 2, opposing pallet P¹, producing the recoil as before. It will thus be seen that two contrary vibrations of the balance take place before a tooth has completely escaped. The banking is to prevent the balance turning round too far, in which case the pallet would be turned away from the wheel, which would of course run down with great force, and break its teeth by striking against the pallets when they turned round again. The best banking is a pin in the balance at B, and therefore moving in a circle round the edge of the cock C, fig. 1, which covers the balance. The extent of the banking is determined by the pin meeting two projecting parts of the cock which reach beyond the circle the banking-pin moves in. The bankings are made as wide as possible, and for the teeth to have a fair hold on to the pallets. Thus, supposing the banking-pin is turned by an accidental jerk to B, fig. 4, the dotted tooth 1 will act on pallet P, and bring the balance round again; and if the banking-pin is at B¹, the tooth 2 will act on pallet P¹, and bring the pallets into action again. The great defect in the verge escapement is the "recoil," the wheels being carried half as far back as they have advanced, consequently the verge and dovetail holes wear very wide, and when so worn the watch cannot go well; the constant rubbing of the wheel-teeth on the pallets wears the verge out, and also the tops off the wheel-teeth, not all alike, but very irregular; hence the wheel often requires topping or recutting. The nose of the potance must be filed to let the wheel up closer, and then the counter-potance filed away to let the follower up, or, what is much better, a new follower must be made. The verge escapement could be constructed much better, but as it is now nearly superseded by the lever escapement, no improvements are likely to be adopted; but as there are a great many verge watches in use, a knowledge of the escapement is still required to keep them in repair.

Four-Legged Clock Escapement.—The following are the particulars of Mr Denison's Four-legged Gravity Escapement for regulating clocks :—

Fig. 1 is a view of the escapement, looking at the back of the clock. Fig. 2 is a section of the escapement and part of the train of wheelwork. The letters refer to the same parts in

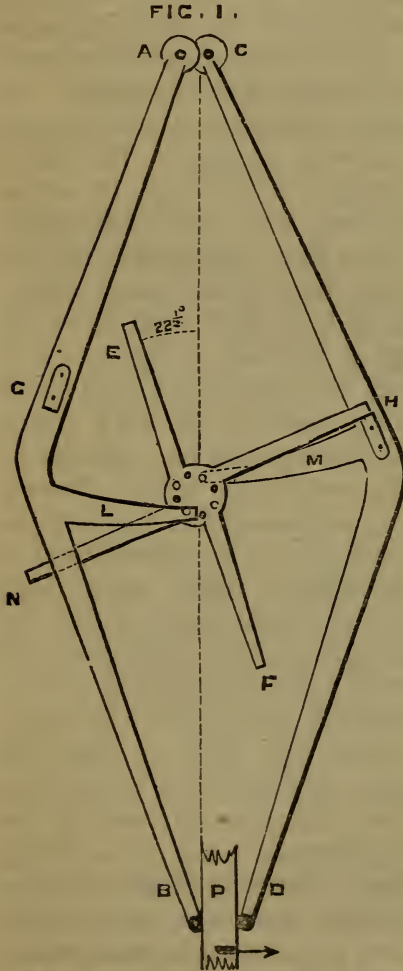

both figures. EF is the scape-wheel of a diameter of three inches, the acting faces of the four teeth being at right angles to each adjacent one. On the central disc of the scape-wheel are set eight pins, four pointing one way and four the other. These pins are $\frac{1}{8}$ of an inch from the centre of the wheel, and one set of four are to be placed on a line with the acting faces of the teeth, and the remaining four equidistant between them.

A, B, C, D are the pallets which are lifted by the pins of the scape-wheel acting on the arms LM. The stops on the pallets are shown at GH, and the proper placing them requires a little attention. In drawing out the escapement, the scape-wheel should be placed within both as at E, and the next look will show the proper place for the stop H to be screwed to the pallet CD. The stop G must be placed a little higher than the stop H. The distance of the pallet

arbors from the scape-wheel centre is 3.5 inches, the arbors being placed as near the vertical line as possible, to avoid friction. The pallets are prolonged until they meet the pendulum-rod, as shown at B and D. The whole of this escapement

should be made of steel. The weight of the pallets must be made such as to cause the pendulum to swing an arc of 4 degrees. A very material feature in this escapement is the fly IK, which is attached to the scape-wheel arbor by a piece of watch-spring in the usual manner. The object of this is to prevent what is called tripping, that is, the pallets A, B, C, D being thrown out too far by the scape-wheel turning too quickly. The fly is large, measuring in total length 4 in. by 1 in. broad. It will be seen by fig. 2 that the pallets are not in the same plane, but that the scape-wheel turns between them. One stop is placed on the front of one pallet, and the other on the back of the other pallet. We will note the numbers of the teeth of the wheels and pinions, which will, we think, be found most desirable.

Wheel No. 1.	120 teeth	drives pinion of	10 teeth or leaves.
„ 2.	80	„	10 „
„ 3.	75	„	10 „
„ 4.	75	„	10 „

The great wheel No. 1 had better be at least $\frac{3}{8}$ of an inch broad on the edge, because these clocks take a heavier weight, about 25 lbs., for a regulator. These clocks have only been made with second pendulums so far as we know, and it may be convenient to state the times of revolution of the various wheels.

The scape-wheel turns once in 8 seconds.			
Wheel No. 4	„	60 seconds.	
„ 3	„	7½ minutes.	
„ 2	„	1 hour.	
„ 1	„	12 hours.	

It is perhaps hardly necessary to remark that the acting surfaces of the various parts of the escapement must be left as hard as they safely can be. It is essential that the fork-pins of the pallets B and D should be so adjusted, that as the pendulum-rod comes into contact with one it just leaves the other. For the reason of this, and for a great variety of information respecting gravity escapement, we refer our readers to Mr Denison's book, certainly one of the most scientific and valuable yet produced on its special subject.

But for the information of those to whom the book is not

accessible, we may explain the action of the escapement. At present one leg of the scape-wheel is resting on the stop H ; the pendulum P is swinging, as shown by the arrow, to the

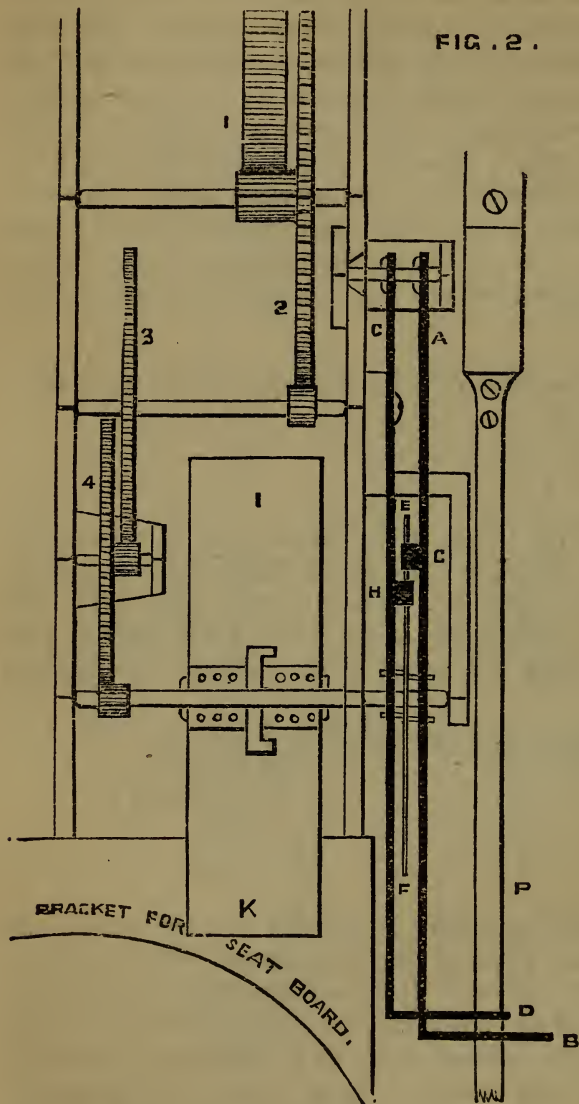

FIG. 2.

right, and will carry with it the pallet CD. As soon as the stop H is lifted out of the way of the scape-wheel tooth, the wheel acted on by the clock-weight will turn until the tooth N is arrested by the stop G, and during this motion of the scape-wheel the pallet AB will be lifted by the pin in the scape-wheel a little outwards to the left, and it is by the weight of the pallet AB acting through the fork-pin at B on the pendulum-rod from that point to which the pallet is lifted by the scape-wheel to that point where the pendulum leaves it that half the impulse to the pendulum is supplied. The pallet

CD on the other side contributes the other half in a similar manner. It will be observed from fig. 2 that the great wheel No. 1, on the arbor of which is placed the barrel for the weight

cord, is at the top of the frame. This arrangement was almost unavoidable with some of the early forms of the gravity escapement, but it will be much more desirable to have the great wheel at the bottom of the frame, and with this form of the escapement there is no difficulty about it. We recommend any one before commencing the actual construction to make fair working drawings of the clock.

Compensating Pendulum.—The following is suggested by a practical watchmaker as a good plan for a compensation pendulum. 1 is the back cock attached to the clock frame. 2 to 4 is the pendulum-rod of flat iron, the middle rod riveted fast to it at 4, and the outside rod riveted to the middle one at 5. 3 is the crutch that works the pendulum. 6 is a screw fast to the pendulum-rod to steady the middle rod, but loose in the middle rod to allow it to expand. 7 is a screw fast to the middle rod to steady the outside rod, but loose on outside to allow it to expand. 8 is the pendulum ball of iron on the outside rod. As the rod from 2 to 4 expands downwards, the middle rod from 4 to 5 expands upwards, and keeps the pendulum-ball in the same position.

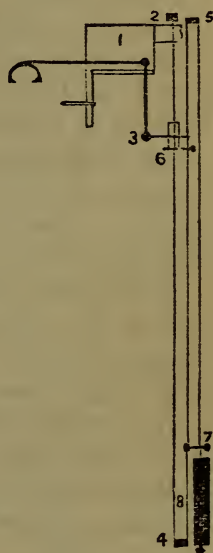

The Chronometer Escapement.—The chronometer escapement is undoubtedly the best timekeeper, the reasons for which are—1. The “impulse” is given to the balance “directly” by the scape-wheel without the intervention of a lever or other obstructing mechanism. 2. The impulse is given in the most favourable manner, “across the line of centres,” and will thus carry a heavier balance. 3. The escapement is more completely detached, hence the isochronism of the balance vibrations are not as much disturbed. The chronometer escapement is thus admirably suited for marine timekeepers, or box chronometers, as they are called, and which are hung in gimbals in a square box like a mariner’s compass. The dial is thus kept always horizontal, and the balance is also kept in one position, that is, working on the cock pivot. The movement is also kept very steady.

The case is very different with a pocket-watch, which has to go in every position, lying up or lying down, and is also subjected to jerks and shakes by the most careful wearer in pulling it out of the pocket to see the time, to say nothing of the shakes and changes of position while it is in the pocket, and the treatment it may get from a careless wearer. A chronometer escapement, therefore, with its heavy balance, is not suited for a pocket-watch. Another objection is that the impulse is given in the one direction only, the unlocking taking place on the return vibration, which receives no impulse; hence if the watch gets a sudden shake in a contrary direction to the way the balance is vibrating, the unlocking will be prevented, and the watch will stop, and will require a good shake to start it again, and also if it is let run down must be shook after winding to start it. The escapement also requires great accuracy of construction, and is otherwise unsuited for rough use.

In the lever escapement the impulse is given at every vibration by the scape-wheel to the lever, and by the lever to the balance. If the escapement is made in the proportions it will not "set," hence will not be affected materially by a sudden shake, neither will it require to be shook to start it on winding it up after being run down. The ordinary lever escapement does not require such extreme accuracy of construction, and is therefore cheaper and better suited for rough use, and will keep time to within a minute a week, which is near enough.

The two-pin lever escapement is considered the best form of lever escapement, but it is thought by many to be not so good as a timekeeper.

A watch, like a steam engine, must be kept in good order. A steam engine cannot be let run long without oil, but will report its sure wants in a manner "not to be mistaken," and a labourer using a wheelbarrow must for his own comfort attend to the "screeching" of the wheel. The trains given to lever and other good watches showing seconds are 14,400, 16,200, or 80,000 vibrations or beats in an hour: each "vibration" means a "revolution" of the balance. Now, either of these sums $\times 24 \times 365$ will give the number of beats or work done in a year. The slowest — 14,000 — gives 126,144,000 beats in a year. A moment's attention to this fact will convince readers that, although the oil used for watches is the best we can get, and may not congeal, yet it

must be all used up in a year or eighteen months ; and then if the mainspring and great wheels are powerful enough to keep the watch going, the pivots and other actional parts must and will wear out—in silence, of course, for watches do not “ screech ” like wheelbarrows.

Double-Roller Escapement.—The lever-watch double-roller escapement is very similar to the ordinary kind of lever escapement with the table-roller, but may be distinguished by its having an additional, though small, roller below that which holds the ruby-pin. The ruby-pin is fixed in the main-roller in the usual way, and serves the same office as that generally known ; but as the guard-pin has no connection with it, the piece carrying the ruby-pin is frequently formed of the shape of an arm, the steel disc being for the most part filed away, leaving only sufficient to secure it to the balance-staff, and to hold the ruby-pin. Thus, then, this part might be called an arm, carrying the ruby-pin. Underneath this is fixed another roller, rather small, having a hollow filed out similar to that which is generally noticed in the ordinary table-roller, the object of which is to allow the guardpiece to pass as the passing hollow

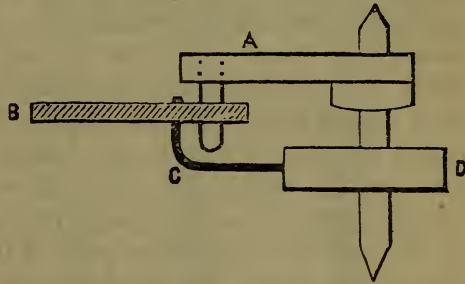

in the table-roller admits the passing of the upright guard-pin in the lever. Looking at the two rollers together when properly fixed, a person acquainted with the crank-roller might think that one and the same object only was achieved ; but it is not so.

Without referring to the crank-roller further, let it be understood that the only purpose of the second-roller in the double-roller escapement is to serve the purpose of the safety action. This is accomplished by having a pin bent at right angles from the under side of the lever, so as to reach sufficiently far to ensure a sound guard-pin depth. So that, in reality, the main-roller is a radial arm carrying the ruby-pin ; then to secure a sound guard-pin depth the small roller is placed below, and the bent guard-pin projects sufficiently long to ensure safety of the escapement.

The annexed diagram will assist in the description :—A, main-roller, carrying the ruby-pin ; B, the lever ; C, the bent guard-pin ; D, the second or safety roller. The balance-staff, of course, passes through both.

To Restore Watch Dials.—If the dial be painted, clean the figures off with spirit of wine, or anything else that will render the dial perfectly clean ; then heat it to a bright red heat, and plunge it into a strong solution of cyanide of potassium ; then wash in soap and water, and dry in box-dust. Repeat if not a good colour. Indian ink ground with gum-water will do for the figures.

Bright's Perpetual Motion Electric Clocks.—Several of these clocks have been in use for four or five years without intermission. An account of them will, therefore, be interesting. Presuming that our readers are acquainted with the general principle of electric clocks, the following account will be understood by referring to the engravings :—In fig. 1 WW are the wires leading to the two poles of the battery. The wire W is attached to the bracket *b*, and the current passes down the suspension of the pendulum, and by a wire, shown by a dotted line, down the wooden stem of the pendulum, then round the coil of wire in the bob of the pendulum, and up the wire on the other side, also shown by a dotted line, to the touching-plate P, and through the leg L of the brake, and off by the wire W to the other pole of the battery, thus completing the circuit when the pendulum is in the position shown in fig. 1.

The bob of the pendulum is thus for the instant converted into an electro-magnet. The tube M is fixed to the clock-case, and contains permanent magnets, which of course attract the electro-magnet in the bob of the pendulum, which thus receives a little additional impulse at every alternate stroke. By the time the pendulum arrives at the other side, as in fig. 2, it has in its journey moved the break B, so that the little balance-weight T has fallen a little past the centre on the other side, and so has brought the leg L' in contact with the piece of glass G on the stem of the pendulum, and has thrown the leg L clear of the touching-plate P, and has thus broken the circuit. The pendulum then makes the return stroke by its own weight, when contact is again made, and so on.

By fitting a double break to the pendulum it receives an impulse at every stroke, instead of every alternate stroke.

It will be observed that the break consists of the two long copper legs L , L^1 , and the balance-weight T , all mounted on a triangular piece of ivory which moves on the pivot p . The friction of moving this break is obviously very little; it is, in fact, so little that one piece of zinc and one piece of coke buried in the ground afford a current of electricity sufficient to drive eight or ten or more of these clocks for a lifetime.

Another feature in this break is that the legs move in an arc of a different radius from that in which the contact-plates move; consequently at each time of touching, the contact-plate receives a slight *rub*, which wipes off any dust, and ensures a perfect contact.

The wires W and W^1 , on their way to the poles of the battery, may communicate with and work other clock-dials. These affiliated clocks are by preference made with pendulums, because if the current misses its errand once or twice, no harm is done, as each pendulum has sufficient momentum to work its own clock for three minutes without assistance from the battery.

In the Continental system of electric clocks the affiliated clocks have no pendulums, but are actuated by a powerful cur-

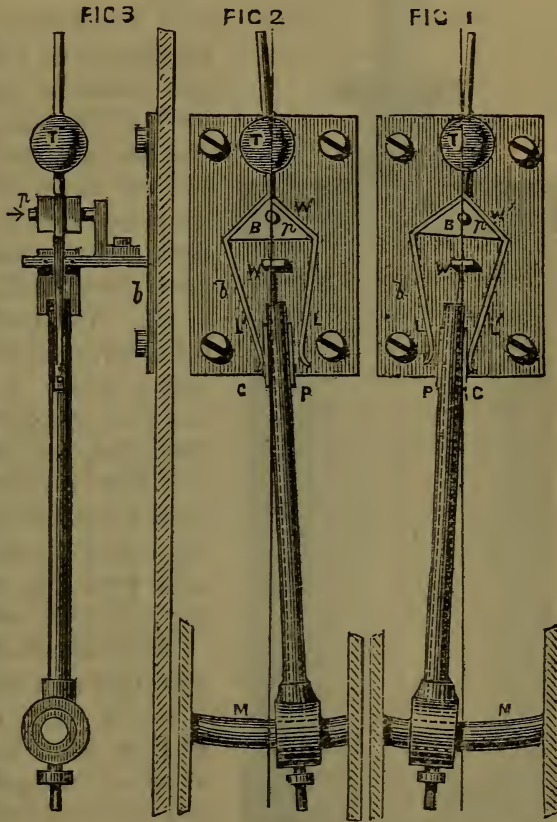

rent from an acid battery once in a minute. Thus, if by any mischance a clock "*misses a peg,*" it is a minute slow at once.

Under Mr Bright's system the pendulums of all clocks in connection are vibrating together, and are in fact always parallel to each other.

A set of four clocks, worked from one piece of zinc 2 ft. square and one piece of coke, have been at work at Leamington for two years; and though they were only a trial set, not over well made, they have never deviated from mean time more than a few seconds per week, and have never deviated from each other at all. The said piece of zinc and coke have been in use during the twenty years in which Mr Bright has been engaged in perfecting his invention, and on the occasion of a visit from a gentleman from Greenwich Observatory for the purpose of inspecting these clocks, the zinc and coke were dug up and found to be apparently as serviceable as ever.

An interesting fact, in connection with this part of the subject, is that a set of three clocks are at work with no other battery than one wire attached to a gas-pipe and the other to a piece of coke.

Also another pair of clocks are at work with one wire attached to a water-pipe and the other to a piece of coke. A set of five clocks may be seen at work at the Gun Cotton Office, 173 Fenchurch Street.

It is thus evident that these clocks require very little power to keep them in motion, and have very little friction, and it may be expected that the liability to

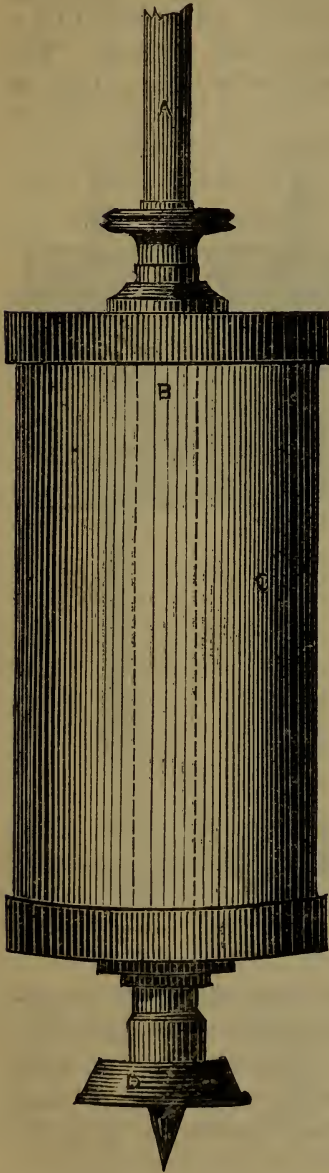

error will be proportionally diminished ; and therefore much may be hoped for them in the direction of good time-keeping, as well as uniformity, both great desiderata for railway and commercial purposes.

Several years ago Mr Gammage invented a mercurial pendulum with the rod passing entirely through the mercury. This pendulum is used for timing compensation work, so that accuracy is indispensable. The springing of a pendulum is a matter that requires much greater attention than it generally receives. Many well-made pendulums are badly sprung, and give off unsteady rates when put to first-rate movements. The following is the description of the instrument :—

A, steel rod passing through tube ; B, tube to which lower cap is attached ; C, glass jar to hold mercury ; D, regulating nut, working on screw cut on lower end of rod.

The jar has a hole cut through the bottom rather larger than the tube, the outer edge is carefully ground into the cap, and when the pendulum is finished it is set with cement.

Mercurial Pendulum.—Fig. 1 represents a pendulum, with a stirrup to support the glass jar. The rod is steel, and about 4-10ths wide by 2-10ths thick. The spring at the top is $\frac{1}{2}$ in. wide, and 2 in. long. The sides of the stirrup are steel, the same size as the rod, and are joined at the top with two steel plates. There are also two short pieces of the rod steel put between the plates and close up to the rod, to form a groove for the rod to slide in, the whole being pinned and screwed up together as shown. The bottom of the stirrup is a circular plate of brass, hollowed out to fit the bottom of the jar, and has two forks to fit the steel sides, and through which the screws are put, as shown at D. There is also a brass cap fitted to the top of the jar, and with forks to fit on the steel sides ; but it is not screwed to them, so that it can be lifted up to put more in, or to take the jar out of the stirrup. The glass jar C is 2 in. inside, and $2\frac{1}{4}$ in. outside diameter, and $7\frac{1}{2}$ or 8 in. long. The height of mercury has to be about $6\frac{1}{2}$ in. ; but can only be got right by experiment ; no two pendulums are alike in this respect, as a great deal depends on the kind of steel used. One great advantage of the mercurial pendulum is, that it can be very readily adjusted. The length of the pendulum from the point of suspension A to the bottom of the

brass B is about 43 in. The bottom of the rod is made into a screw, and has a large milled and divided nut screwed on for regulating the clock. There is also an index screwed on to the plate to show how much the nut is turned round. The screw may be 20 to the inch, and the nut divided into 50, so that if the nut is turned round one division, it will raise or lower the stirrup one-thousandth of an inch. Having tried the clock to see how much it gains or loses, the following rule is given to ascertain how much to alter the nut, to bring the clock to time at once:—Multiply the theoretical length of the pendulum by 2, and by the number of seconds gained or lost in a day, and divide the result by the number of seconds in a day; the quotient will give the parts of an inch by which the pendulum must be lengthened or shortened. The theoretical length of a seconds pendulum is 39.2 in., and the seconds in a day 86,400". Now suppose the gain of a seconds pendulum to be three minutes per day, we have $39.2 \times 2 = 784 \times 180 = 141120 \div 86400 = .163$ parts of an inch, that is, three turns and 13 divisions of the nut by which the pendulum is to be lengthened; if the clock had been losing, of course the pendulum would require to be shortened. Mr Denison says, in his work on "Clockmaking," if the screw is 16 to the inch, and the rod 43 in. long, one turn of the nut will

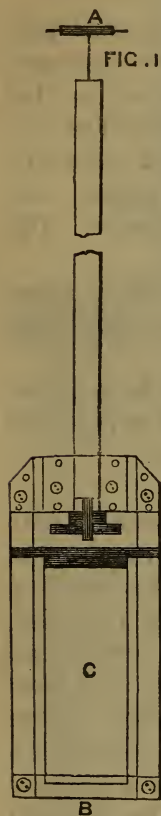

alter the clock one minute per day; so that if the nut is divided into 60, one division will alter the clock a second a day. Cold weather is the best for adjusting compensated pendulums, as

Fig. 2.

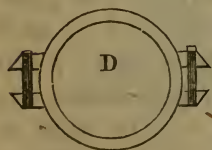

the temperature of the clock-room can be raised by fire or gas, and lowered by letting the fire out. To adjust the mercury, let there be only 6 in. in the jar, and regulate the clock in the cold room, so that it has a losing rate of say five seconds a day; now raise the temperature, and note if the clock loses still more, if so, more mercury is required: put in a little: now see what the rate is, and then lower the temperature, and see

if the rate is the same. If the rate is less when the temperature is lowered, put in some more mercury, and again note the rate and raise the temperature, and see if the rate is altered, thus repeating the process until the rate is the same, as near as can be, in heat and cold. The final adjustments had better be left perhaps for summer and winter, as long-continued experiments and observations are required to obtain satisfactory results. Adding to the mercury will reduce the original rate five seconds a day, so that the clock will be brought to time without altering the nut at the bottom of the rod; of course, if the nut has to be altered, the compensation will have to be adjusted again. Unless the clock is a good one, perfect in all other respects, it is not worth a compensated pendulum.

Reducing Hair-Springs.—Hair-springs may be reduced by rubbing them down on a flat oil-stone with spirits of wine instead of oil. Use the middle finger, giving a circular motion to the hand while rubbing, and let the pressure be even, but not too hard, or the spring may get injured. If the watch gains more than five minutes a day, it will be less trouble to put in another spring. The strength of the springs can be tried by weighing the balance with the spring, thus: Lay hold of the outer coil of the spring in the tweezers, and “hook” the inner coil on to the foot of the verge or cylinder, and lift the balance up, the spring will thus be pulled down into a “taper spiral;” the weak springs will, of course, have longer spirals than the strong ones. Lever staffs must have a bit of wax or pegwood stuck on to the foot pivot, and to which the spring can be hooked. The strength of spring required depends on the diameter and weight of the balance, and the number of beats or vibrations per hour, technically called the “train.” The only way to tell if a spring is the proper strength is to put it on the watch and try it. The springs are sold sized in diameters and strengths, and if we could get the balances sized in diameters and weights, after a few experiments we should be able to select the proper spring at once. The results of experiments should be entered in a book for future reference thus:—

TRAIN.	BALANCE.		SPRING.	
	Weight.	Size.	Strength.	Size.
16,200	10	10	10	10

This method is proposed for plain balances only ; for superior watches, with compensated balances, the isochronism of the hair-spring has to be ascertained.

Strength of Mainsprings.—The reason a verge watch gains when the strength of spring is increased is that the balance is always connected with and influenced by the mainspring or maintaining power. Thus, when a tooth of the scape-wheel has given impulse and escaped from one pallet, another tooth drops into the other, and by the “recoil” exerts the full force of the spring to shorten the vibration, and thus makes the watch go faster. The horizontal escapement is used in Geneva watches, and to this escapement the impulse is given by the oblique faces of the table acting on the edges of the cylinder as they pass out. The teeth, after giving impulse, drop on to the outside and into the inside of the cylinder alternately, and remain “dead” during the vibration. The impulse is given when the balance is near the quiescent point, and the balance is then left to finish the vibration by the combined action of the hair-spring and its own momentum, without being influenced by the maintaining power. If a stronger spring is put in, the impulse will be more intense, and would cause the balance to vibrate quicker ; but the “friction” of the teeth on the inside and outside of the cylinder is also increased, and thus counteracts the extra strength of the mainspring. It will thus be seen that a fusee is not required to equalise the power of the mainspring, as the watch will keep the same time within moderate limits whether the spring be weak or strong. In verge watches, on the contrary, a fusee is an absolute necessity, and the spring must also be “set up,” so that it is as strong at the bottom as it is at the top. For this purpose watchmakers use an “adjusting rod,” which is a steel rod with sliding weights upon it, and a pair of jaws to secure on to the fusee square. The rod can be bought at the tool-shops for about 1s. 6d. To adjust the mainspring the watch is put together without the third wheel, and is held in the left hand edgeways with the fusee and barrel at the top. The rod is secured to the fusee square with the weights at the bottom. The watch must now be wound up, and the weights moved along the rod until the spring will just pull the rod “over.” The right hand must be kept in “front” of the rod, and thus ease it over, for if it is

let go over too sudden it will break the chain. Having set the weights so that their "leverage" and the strength of spring when wound up are counterpoised, the watch is let down and the spring "set up" until it will pull the rod over with the same force as it did when wound up, or as near as can be, for if the fusee is not long enough and of the right shape, it will not be possible to get it exact. In marine chronometers the shape of the fusee is altered until the force is equal in every turn, but such extreme accuracy is of course unnecessary in pocket watches. The strength of spring required depends on the size of the watch, and also whether it is in perfect repair or not. When the holes and pivots are worn, the wheels often rub each other, especially in thin movements; and if new holes are put in, it is seldom the wheels are so free or the depths (pitchings) so good as they might be, hence a stronger mainspring is required to pull the watch along. The strength of the springs depends on their breadth and thickness taken together, but should be as wide as the barrel will allow without rubbing the cover, and must not be too thick, or they will not make turns enough in the barrel. To ascertain the number of turns required,

wind the chain on the barrel and count the turns, allowing half a turn for the spare end, which is not wound on the fusee. In verge and Geneva

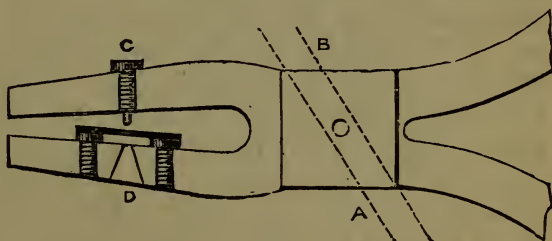

watches four effective turns are required; and if we allow half a turn for "setting up," the spring must make at least $4\frac{3}{4}$ turns in the barrel. To do this, the spring should occupy one-third of the barrel, the arbor one-third, and one-third space. In lever watches the barrels are smaller, and the spring should make $3\frac{1}{2}$ turns in the barrel. Most lever watches have a fusee, but do not require adjusting; in fact, the fusee is too short to be correct. Above is a sketch of a mainspring punch made in a pair of common pliers thus: Drill a hole through both jaws from C to D; tap a screw into C with the bottom end turned down for the punch; chamfer the hole D with a taper-drill to free the punchings; fit a bridge over the hole D between the

jaws, and file away the sides, so that when the spring is put through the bridge and pressed obliquely against the sides, the punch will punch the hole in the middle of the spring, as shown by the dotted lines at BA. This punch answers well, and the pliers can be used for putting in pins as usual without any inconvenience. A smaller punch in a pair of long-nosed follower pliers without the bridge is also useful. With these a hole can be punched in the inner coil of a spring for the barrel arbor without uncoiling the spring. The above punch can be also recommended on the score of cheapness, as the pliers cost only 1s., and the old-fashioned punch to screw in the vice costs 1s. 9d., and the clumsy Swiss mainspring nippers cost 6s. 6d.

Geneva Cylinders.—The length of a cylinder can be obtained by the following method:—Take off both jewel covers, screw on the cock, and take the distance outside the jewel holes with a pair of pinion gauges—this is the entire length, pivots and all. The diameter is obtained from the scape-wheel thus: If the foot of the cylinder is held between two teeth and against the point of one, the heel of the next must be quite free of the cylinder. With a depthing tool, the watchmaker can put the scape-wheel and cylinder into it, and see if the cylinder has the same freedom inside and outside, that is, the tooth should have equal “drop” into the inside and on to the outside of the cylinder; but the point of the tooth should not drop too far into the cylinder—just enough to be safe is all that is required. There are three dots, one on the plate close to the edge of the balance, and another on the rim of the balance to mark the place for the hair-spring stud, and when the balance is at rest, the dot on it is close to the middle one on the plate. In new watches these dots mark the extent of the balance and of impulse, that is, a tooth escapes when the dot on the balance reaches the outside dots on the plate. Before the balance is riveted too tight the cylinder should be put in and tried, and the balance turned round on the cylinder until the teeth escape at the dots; you will thus get the banking, and also the escapement, right at once.

Silver Dial Cleaning.—Take about a teaspoonful of salt-petre, and mix it with about two dessert-spoonfuls of finely-powdered charcoal—willow coal is the best. Let these be ground together with a little water on a piece of slate, with the

blade of a knife, then, by the aid of a camel's-hair pencil, spread a portion of the mixture evenly over the surface of the dial, which must then be laid on a piece of charcoal, and with a blow-pipe, and the clear flame of a lamp or gas jet, it must be made just red hot, and kept so till the wet powder has ceased to fly about ; it must be then thrown from the charcoal, hot as it is, into a mixture of sulphuric acid and water (in the proportion of about one fluid ounce of acid to three half-pints of water) ; it will then have a snow-white appearance, and must be washed with a brush and soap in clean soft water, and put into fine sawdust till quite dry, or, what is better, rosewood raspings.

To Make a Chronometer Oven.—A box suitable for testing watches with compensation balances, or even the effect of high temperatures upon aneroids, may be very efficiently constructed as follows :—

Make an outer box, either of mahogany or oak, and line it with sheet-iron or block tin ; let it have an aperture in front large enough to admit of lighting the gas jets, which must be placed in the apparatus to obtain the required internal heat, the pipe for which should lie at the bottom of the box bent in the form of a circle. At about four inches from the bottom a diaphragm of perforated sheet-iron should be fitted. It need not be made a fixture, but should be supported by brackets at the corners. This diaphragm will receive the principal heat from the jets, and tend to distribute it more equally. In the interior space a sheet-iron trough, with overlapping edges, should be placed so as to rest upon the rim of the outer box. Its dimensions should be such as to allow a space of two or three inches in clearance at the sides and bottom between it, the outer box, and the diaphragm. Lastly, a light lattice-work cradle, made of wood, should be placed inside the inner iron box, for the purpose of holding the chronometers, watches, or aneroids to be tested. The lid to the whole apparatus should have a panel of plate-glass through which the contents of the cradle will be visible always. The lid should fit closely at the edges, so as to retain the heated air in the cradle. Apertures must, of course, be provided at the upper portion of the outer box to permit the products of combustion to escape. These apertures should be provided with sliding shutters or covers, to admit of

them being entirely or partially opened so as to regulate the draught, and thereby the temperature of the interior. The dimensions of the various parts are not given, as the size of the box must depend upon the various requirements of different individuals.

Gauge for Measuring Watch-Hands.—The following engraving and description of a gauge for measuring watch-hands is forwarded by Mr David Meek of Edinburgh :—

The gauge stands upon three pillars $\frac{1}{2}$ in. long, and consists of a disc of brass $2\frac{1}{2}$ in. in diameter. In the centre of this disc is a steel-pumping centre, while around it are engraved 21 circles.

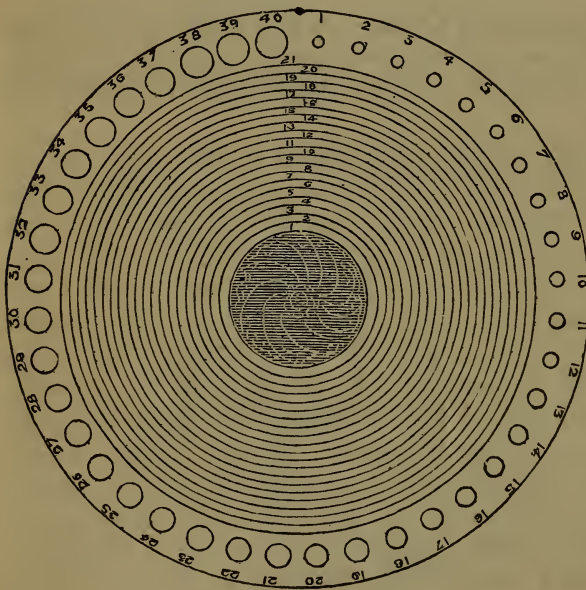

These circles are to show the lengths of the hands, and are sufficiently varied for hour and minute hands of every kind. On the outside of the 21st circle are placed 40 steel studs about 3-16 of an inch long, and slightly tapering, and of different sizes, No. 1 being the smallest, and 40 the largest. The object of these studs is to gauge

the size of the hour-hand sockets, and like the circles for the lengths are so varied that they embrace every size of socket from the smallest Geneva up to the largest English one.

As few watchmakers would feel inclined to purchase a hand-gauge, owing to its expense, the inventor has, to remove this difficulty, engraved a steel-plate with circles on it, corresponding in size and number to those upon the real gauge, and with small rings, corresponding exactly in size with the steel-studs, by which the hour sockets are sized. From this plate cards

have been printed, which serve nearly as well as a real gauge, without its expense.

To ascertain the length of a hand by this gauge-card, place the socket or square exactly over the small dot in the centre, and see which circle the point reaches to. To obtain an hour-hand with a particular size of socket, take the size of the hour-wheel socket with a pinion-gauge or spring callipers, and then see with the callipers what ring corresponds in size. The white space within the rings denote the size of hole in the hour-hand.

As there are at least 400 different sizes of hands in general use amongst the various kinds of watches, the watchmaker cannot fail to see the value of a gauge which enables him to obtain any size of hand he is in want of, or those sizes most suitable for his trade, besides its other advantages, such as the saving of time, surplus stock, &c.

Another arrangement which renders the gauge-card still more efficient is by placing the watch-hands

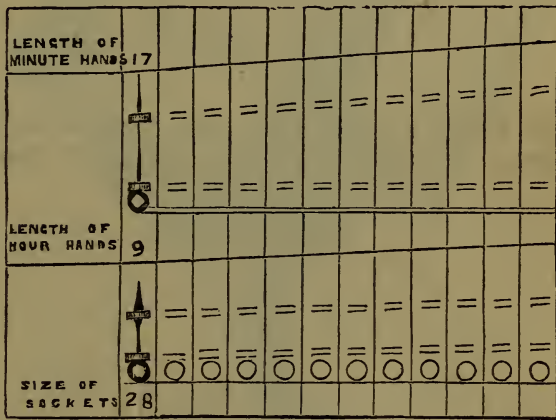

on a gauge similar to the second one. The gauge has the size of sockets as well as length of hand marked opposite each. As the spaces get empty, they can again be replaced by merely referring to the numbers marked within the empty spaces, the hands being fixed on the card so as they can be taken off and again replaced with little trouble.

Watch Oil, to Purify.—Fill a phial three parts with olive oil, and hang it up in a window for six months, where it is exposed to every change in the weather. The impurities will then be precipitated.

Horizontal Sun-Dial.—This sun-dial does not require the assistance in making it of a dialling scale—an instrument not

always to be readily obtained. On the centre E describe a circle. Through E draw the line DE, also HL, for the 12 line, at right angles to DE. Choose a point, say L, on the line HL, below E ; through

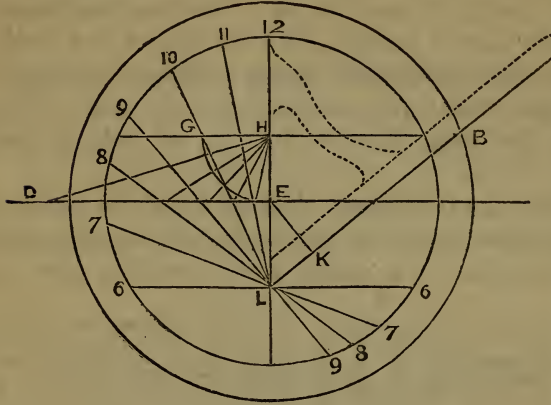

be found at K. Then turn your compasses, and mark the point H on the line LH ; through H draw a line GH parallel to DE. From H, with the distance HE, draw the arc HEG. Divide this arc into six equal parts ; then from H draw lines through the points of division in the arc to the line DE ; then from the point L draw lines for the hours through the line DE, at the points where the lines which divide the arc meet the line DE.

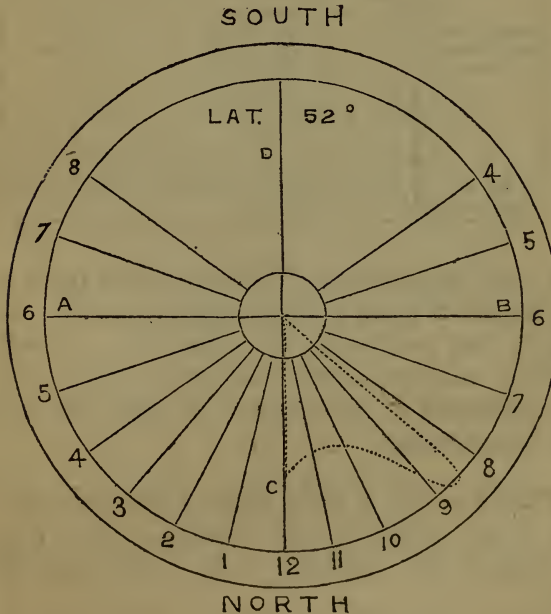

SOUTH

LAT. 52°

NORTH

Another method.
—Proceed as directed below, and you will obtain an accurate dial. Draw the lines AB and CD at right angles to each other, and at the

—Proceed as directed below, and you will obtain an accurate dial. Draw the lines AB and CD at right angles to each other, and at the

intersection of which as a centre, describe the concentric circles, the size of the dial required. The line AB is the six o'clock line, and the line CD the meridian or twelve o'clock line. To fill up the intermediate hour lines, 7, 8, 9, 10, and 11 in the quarter CB should be measured by degrees from the meridian line; that is, from 12 to 11 the distance should be 11 degrees and 55 minutes; from 12 to 10, 24 degrees and 26 minutes; from 12 to 9, 28 degrees and 13 minutes; from 12 to 8, 53 degrees and 44 minutes; and from 12 to 7, 71 degrees and 9 minutes. The quarter AC must be the same, and the hours 4, 5, 7, and 8, on the south side of the six o'clock line, should be diametrically opposite the same hours on the north side. The gnomon, as shown in dotted lines, should be an angle of 52 degrees, and raised directly over the meridian, or twelve o'clock line.

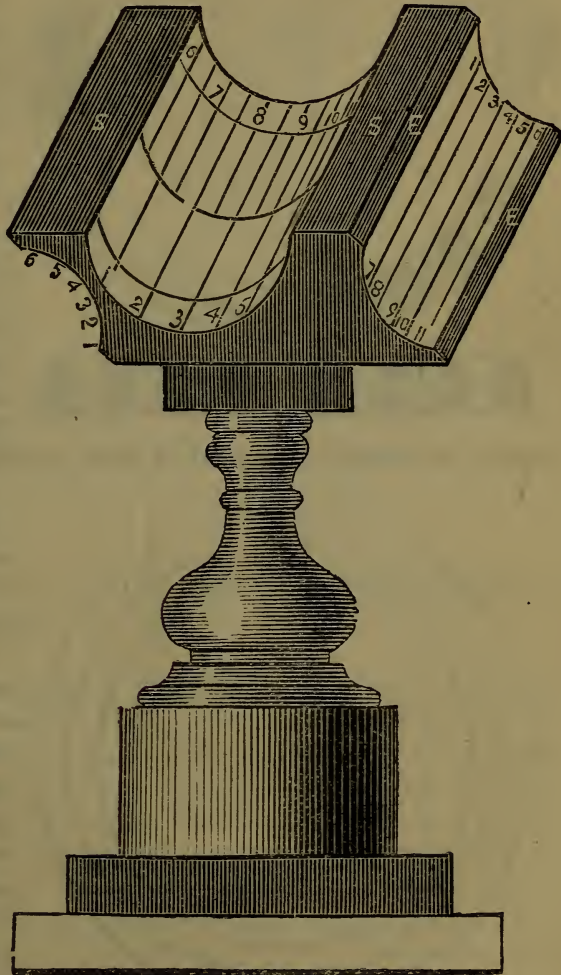

Inexpensive Sun-Dial. — The sketch shows the upper part of a cubical stone, hollowed out on three sides, and set up in a slanting position. The hollows form half a circle.

The western side cannot be shown in the sketch, but it is the same as the east with the figures reversed. The dark angles

of the sketch throw the shadow on the hollow part. It is set in the usual manner.

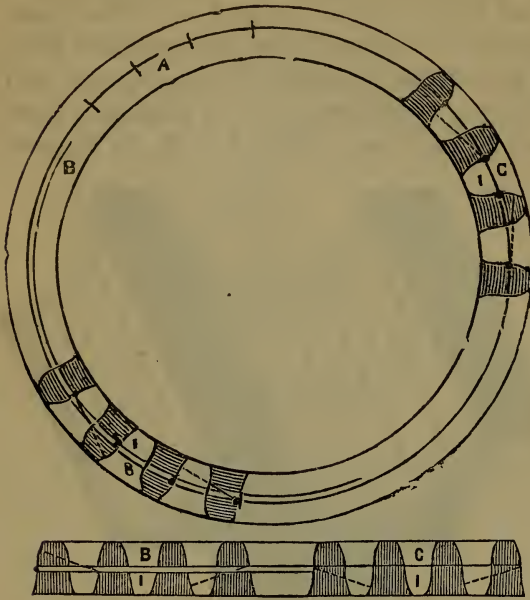

according to strength, the kind of work, and different speeds.

Pinion and Rack.

—To strike out a pinion and rack, proceed as follows: We presume you have your diameter of pitch-line A. Divide it out for the teeth at A, and strike them out as shown at B^r and C^r. The B^r in both are struck from a drop-line D, as shown by the dotted lines, and C^r are struck from the pitch-line alone. There are many variations, according to strength, the kind of work, and different speeds.

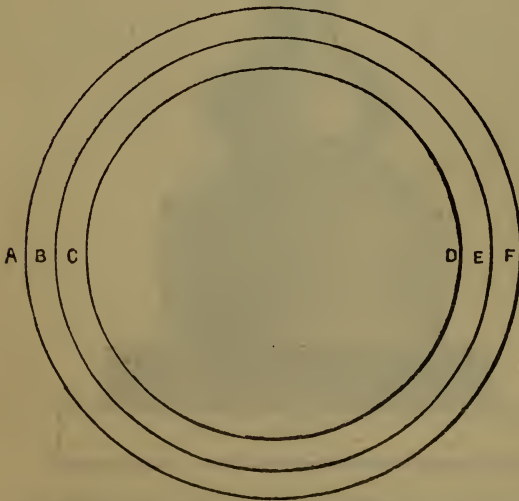

same as if we measure from B to E.

Diameter of Circle.

—To get at the diameter of the pitch-circle, let AC and DF be the top and bottom of the teeth of a wheel, then B and E will represent the pitch-circle. It will be clear that if we measure the diameter of C, the bottom of the teeth on one side, to F, the top of the teeth on the other side, it will be the

Epicycloidal Wheel.—A method of converting circular into alternate motion, or alternate into circular, is shown in the accompanying sketch. A is a fixed internal-toothed annular wheel ; the pinion B

is attached upon a crank arm CE, which has its centre of motion at E, and carries the centre C ; the rod D being attached to the pinion B (which is half the size of the annular wheel) at F, the circumference of revolution of the D pinion is thereby made to describe the right line DG, coinciding with a diameter of the annular wheel, which is therefore equal to the length of the stroke of the engine to which it may be applied. This arrangement admits,

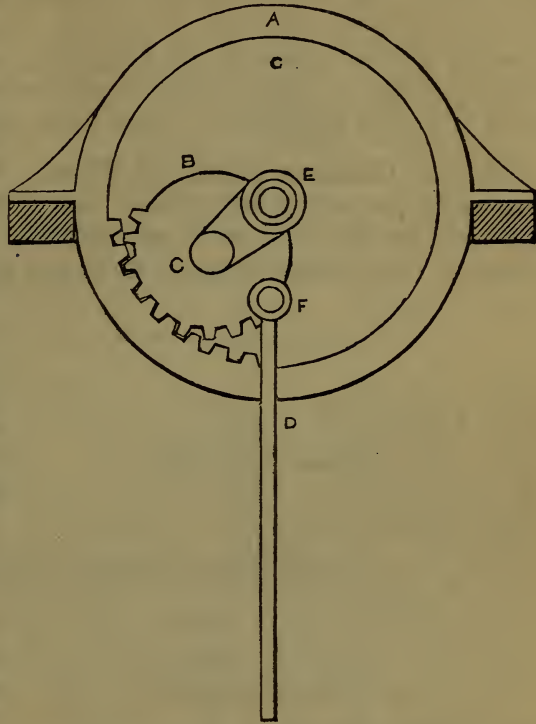

in small engines, of a very elegant application known as White's parallel motion.

Glass, to Cut without a Diamond.—This operation unites utility with amusement. Take a bit of walnut-tree, cut one end to a point, put that end into the fire till it is red hot ; while the stick is burning, draw on the glass with ink the form you mean to cut ; then take a file, or a bit of glass, and scratch the place you intend to begin your section ; then take the wood red hot from the fire, and lay the point of it about the 1-20th part of an inch from the marked place, taking care to blow always on that point, in order to keep it red ; tallow the drawing traced on the glass, leaving the same interval as before. The pieces, with slight pressure, will then divide.

Another method.—Take any vessel you want cut, and, having

heated a poker in the fire till it is almost red hot, but not quite, apply it to the part you wish the crack to begin. Having held it to the part for about a minute, remove the poker, and wet the place; the glass will immediately crack. Having now begun the crack, you may lead it in any direction by merely drawing the hot poker in the direction you want. This is extremely useful in many chemical experiments, where you are in want of proper apparatus. Glass tubes may be cut with a file.

To Cut Circular Pieces of Glass.—If the amateur has a turn-table on which he mounts his objects, and a writing diamond, he has all that is required to cut the circular pieces of glass. It is only necessary to fix the square pieces of glass

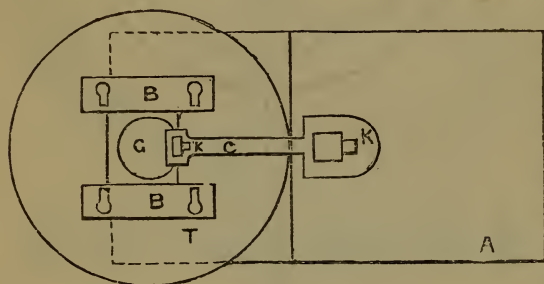

on the centre of the table, and hold the diamond with the right hand while he turns the table with the left.

The following diagram will illustrate all that is required:—A is the stand for table; T, table; P, pole fixed into stand of table; C, arm to hold the diamond; K, K, K, keys to tighten the aim C and the diamond D; G, the

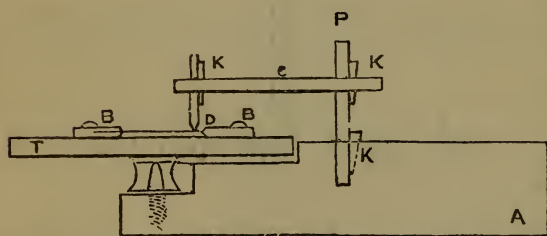

square piece of glass fixed to table by the two pieces of brass B, B, which each have two holes, so as to tighten the piece of glass G. The pieces of brass are fixed by two screws, as can be seen. These two pieces of brass will do to hold the slide on the table when required for mounting objects.

To Cut a Circular Hole in a Sheet of Glass.—Drill a number of small holes close together to form a circle as large as the hole is required to be, then join the holes with a small file. The drill must be quite hard, and both drill and file wetted with spirits of turpentine and oil of lavender.

Designs on Glass.—A mode of effecting this, which is a modification of the process by which copperplate engravings on paper are transferred to porcelain, has been invented in France. As fine-lined copperplate engravings would not adhere to glass, others having considerable depths are used; also, to impart to the enamels that thickness which the glass requires, stearates and oleates are added to the silicates and borosilicates, which serve to support or to fuse the coloured and colouring oxides; and, for a vehicle, a solution of resin in ether or benzine is added to the mixture. Impressions, taken mechanically on paper with this ink from engraved rollers, are transferred to the glass, which is then treated as in similar processes with porcelain, and is finally placed in the furnace. Effects of great artistic merit are thus obtained at a trifling cost.

To Transfer Engravings on Glass.—Metallic colours prepared and mixed with fat oil are applied to the stamp on the engraved brass or copper. Wipe with the hand in the manner of the printers of coloured plates; take a proof on a sheet of silver paper, which is immediately transferred on the tablet of the glass destined to be painted, being careful to turn the coloured side against the glass. It adheres to it, and so soon as the copy is quite dry, take off the superfluous paper by washing it with a sponge; there will remain only the colour transferred to the glass, which will remain fixed by passing the glass through the ovens. The basis of all the colour employed in painting on glass are oxidated metallic substances. In painting on glass it is necessary that the matter should be very transparent.

To Draw on Glass.—Grind lampblack with gum-water, and some common salt. Draw the design with a pen or hair-pencil.

To Paint Glass Gold Colour.—Take silver 1 oz., antimony $\frac{1}{2}$ oz. Mix them in a crucible, then pound the mass to powder, and grind it on a copper plate; add to it yellow ochre or brickdust, calcined again, 15 oz., and grind them well together with water.

To Paint Glass Red.—Take jet 4 oz., litharge of silver 2 oz., red chalk 1 oz., powder them fine, and mix them.

Materials for Opaque Enamels.—Calcine 30 parts of lead with 33 of tin, with the usual precautions; then take of this calcined mixed oxide 50 lbs., and as much of powdered flints (prepared by being thrown into water when red hot, and then ground to powder), and 8 oz. of salt of tartar; melt the mixture in a strong fire kept up for ten hours, after which reduce the mass to powder.

Micagraphy.—This is the name given to a new process of producing ornamental effects on sheets of mica. The use made of this new process has been as yet confined to the ornamentation of lamps and shop-windows, but it may be used as a cheap substitute for stained glass. The sheets of mica can be painted in any required manner, and the work preserved, it is said, by means of a varnish, or the painting may be fixed like enamel on the mica by the use of different pigments and the aid of a furnace, the pieces of painted mica being afterwards fixed, with the coloured side within, on the glass of the windows. This is the mode of proceeding:—After the mica is split into laminæ and trimmed into shape, it is glued down upon cardboard to be polished and printed. The former operation is performed by means of a soft rubber moistened with a solution of soap or sulphuric acid extremely diluted with gum-water: the printing is performed in the ordinary manner or by transfer, in order to present the design in the natural position so as to be seen by transparency. Opaqueness is produced by a previous coat of varnish or a metallic ground obtained by means of leaf or powder. The colours are laid on as in illuminated works, and the ordinary pigments may be employed, and afterwards covered with a transparent spirit varnish, or, as before stated, enamel colours may be used and the sheets passed through the fire. It is admitted, however, that in the latter case one great advantage of the process, namely, cheapness, is in a great measure sacrificed. When the ornamentation is completed, the mica is removed from the card and fixed on glass, or any other substance, by means of a solution of gum sandarac and mastic in potash and alcohol. It is said that, with ordinary care, the junction of the pieces of mica in a mosaic or other work is quite imperceptible, so that, in the case of a painted window, there is no other limit but the size of the glass on which the mica is fixed.

Soluble Glass.—A covering for decayed wood and other practical purposes. Fifteen parts of powdered quartz, 10 of potash, and 1 of charcoal. These are melted together, worked in cold water, and then boiled with 5 parts of water, in which they entirely dissolve. It is then applied to wood-work, or any other required substances. As it cools it gelatinizes, and dries up into a transparent colourless glass on any surface to which it has been applied. It renders wood nearly incombustible.

Woods, Strength of.—The strength of different woods to resist a compressive strain depends upon the value of the absolute force or weight which has been found by experiment to crush them, and which has a very wide range. The annexed table shows the crushing weight for all the woods which are used in the various branches of constructive art, and from these numbers and simple rules it will be easy to calculate the strength of pillars of different lengths and sizes.

Description of Timber.	Crushing Weight in cwt. per square inch.	Safe Load in cwt. per square inch.	Timber, where Grown.
Alder.....	61'50	15'40	England.
Ash.....	80	20	...
Birch.....	104	26	America.
Beach.....	83	21	...
Box.....	92	23	...
Elm.....	92	23	...
Ebony.....	170	42'25	West Indies.
Hornbeam.....	65	16'25	America.
Larch.....	50	12'50	England.
Mahogany.....	73	18'25	Honduras.
Oak.....	89'25	22.25	England.
...	53'50	13'40	Canada.
...	68'75	17'20	Dantzic.
Pine (Red).....	51'75	13	America.
Pine.....	48	12	The Baltic.
Sycamore.....	63'25	15'80	England.
Spruce.....	61	15'25	America.
Teak.....	108	27	Africa.
Watergum.....	90	22'50	East Indies.

Warped Wood.—The best method of straightening warped wood is to wet it well on the hollow side, and clamp a piece of hot wood top and bottom with hand-screws, such as cabinet-

makers use, until cold ; then, if convenient, screw a piece of hard wood on the under side, and let it remain on. Another plan is to cut down the middle, shoot the edges, glue together again, and plane flat.

Dovetailing.—In plate 1 several ways of working are shown, but as much depends upon the parts being properly proportioned which are to fit into each other, so that the pin or socket, partly represented in fig. 1, called the pin of the dovetail, and that in fig. 2, called the socket, shall be as nearly as possible of equal strength, we lay down some rules for the guidance of the workman, and here refer to the pin only in fig. 1, for the socket is made to correspond to it. Let ABCD be a scantling required to be joined to another by means of a single dovetail. Now as much will depend on the form of the dovetail as the proportion it bears to the parts cut away, we will endeavour to lay down the principle on which the greatest strength is maintained. Having squared the ends of the scantling, and gauged it to the required thickness AIKLM,

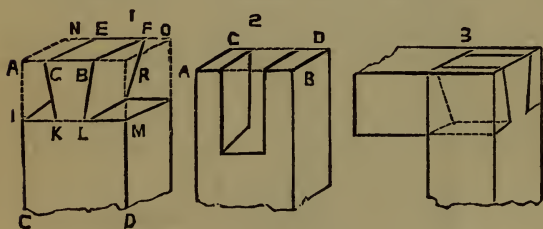

divide IM into three equal parts at KL. Let KL be the small end of the dovetail, and make the angles IKG and MLH equal about 75 or 80 degrees. Now make GE and FH

parallel to AN and BO. Here introduce the saw, and cut away the pieces AIKGEN, and BMLH FO ; and having cut fig. 2 to correspond by making the form of the dovetail on the top of the piece ABCD, it will fit together, as shown in fig. 3.

According to the texture of the wood, we may make the bevel of the dovetail or angle IKG, fig. 1, either more or less. Hard, close-grained wood, not apt to rive or split, will admit of a greater bevel than that which is soft or subject to chip: thus the dovetail in deal must be beveled less than that in hard oak. It is a fault in many workmen that they give the dovetails too much bevel, which, instead of holding the joint firmly together, weakens it. This may be observed if we compare the dovetailing of the cabinetmaker and the joiner ; the former

has very little bevel, while the latter has very much. Even with respect to the appearance of the work, the one looks neat, and is at the same time strong; while the other, appearing to aim at great strength, looks clumsy, and is in reality the weaker. Fig. 4 represents the dovetail in common use for drawer fronts, &c., when it is wished to hide the appearance of the joint in front. The board ABCD is cut with the pin, and AEFB with the socket; the pins in this sort of dovetail are in general placed one inch apart. Fig. 5

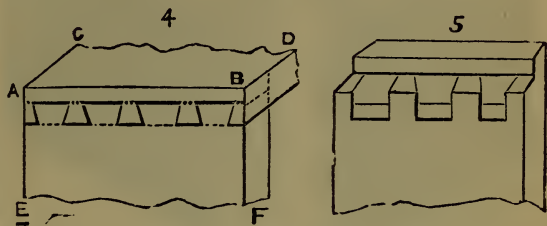

represents the pin part of tap dovetail, which when put together shows only a joint, as if the pieces were riveted together, as shown in fig. 6; the part ABCD represents the pin, and the part EFGH the socket dovetail, and when put together only shows the line HG as a joint; and if the corner AB is rounded to the joint GHT, it will appear as if only mitred together. This kind of dovetail is very useful for many purposes where neatness is required. Fig. 7 is a still neater dovetail. Instead of the square shoulder or rebate in AB, it is cut into a mitre, and the other piece is made to correspond. Another very neat way is shown in fig. 8,

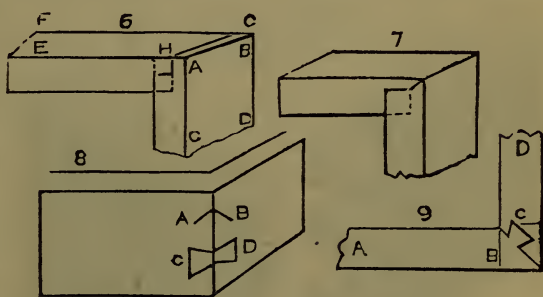

where the joints are first formed into a simple mitre, and then keyed together either by making a saw kerf in a slanting direction, as shown at AB, or by cutting out a piece as at CD in the form of a dovetail, and fitting a slip in of the required form. The first method, as AB, is amongst workmen called keying together; the second, as CD, is key dovetailing; the last method is shown at fig. 9, and may be termed mitre dovetail grooving, the part AB being formed with shoulders cut to the required bevel, and a piece left for

the pin dovetail, which is inserted into the socket dovetail, made to correspond to it in the piece CD, which has been previously formed into a mitre. This method, though not much employed, may be used with great advantage in many cases, particularly when we wish to join any pieces together the lengthway of the grain.

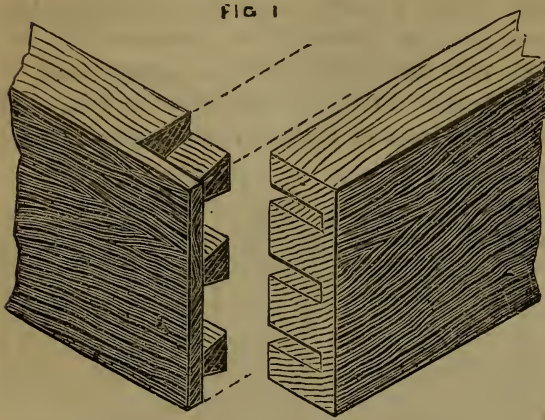

Annexed are three other illustrations of dovetailing, sufficiently shown in the engravings as to need no further description.

Wood Staining.—*To Stain Wood a Mahogany Colour before Polishing.*—Make a strong or weak solution of logwood, according to shade required, to which add a few drops of

hydrochloric acid; then stain the article. When dry, give a coat of linseed oil, and it is ready for polishing. If boiled or strong drying oil is used, a much darker shade is obtained; with the latter it becomes almost black.

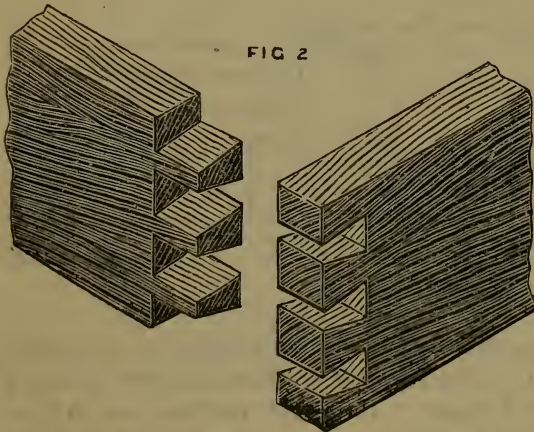

Another method.—Boil logwood chips in water, adding a little soda or potash to bring out the colour. Apply with a brush, and use French polish when dry.

Rosewood Stain.—A stronger decoction of logwood must be

used.

used, and the process must be repeated several times. To produce the fibres, put some iron-filings or turnings in strong vinegar; let it stand for some years, and then brush the wood over with the solution. When dry, polish with bees-wax and turpentine.

Another method.

—Dissolve half a pound of potash in 2 gallons of water, and add to it half a pound of red sander-wood. When all the colour is extracted from the wood, add 5 pounds of gum shellac, and dissolve it over a

quick fire. This stain should be used on a ground previously with logwood stain.

Another method.—If with a brush dipped in the brightening liquid you draw veins on wood prepared with the black stain, a very good effect is produced.

Red Stain for Bedsteads and Common Chairs.—Lay on one or two coats of common archil, and when dry brush over with a hot solution of pearl-ash in water.

To improve the Colour of Stains.—With 2 oz. of nitric acid diluted with 4 oz. of water, mix a teaspoonful of muriatic acid and $\frac{1}{2}$ oz. of grain tin. Keep in a bottle well corked, and use after it has stood two days.

To Stain Beech a Mahogany Colour.—In a pint of rectified spirits of wine put an ounce of dragon's blood. Shake the bottle which contains it frequently until the dragon's blood is dissolved. When this is the case, the stain is ready for use.

Black Stain for immediate use.—Take 1 lb. of logwood chips and boil in 4 quarts of water, and lay it on the work while hot. Make a similar decoction of logwood to the last, and add to it 1 oz. copperas and 2 oz. verdigris; strain and put into it 1 lb. of rusty steel filings, and with this go over the work a second time.

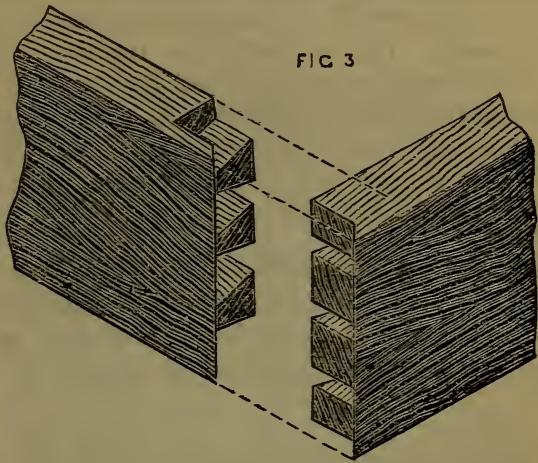

Protection of Wood Carvings.—Worm-eaten wood may be saved from further ravages by fumigating it with benzine, whereby the worm is destroyed. Another way is to saturate the wood with a strong solution of corrosive sublimate—a process which may be advantageously employed to protect carvings in wood. But as sublimate destroys its colour, it will be necessary to restore the latter by ammonia, and then by a very dilute solution of hydrochloric acid. The holes made by the worm may then be injected with gum and gelatine, and a varnish of resin dissolved in spirits of wine should afterwards be applied to the surface.

Shooting Boards for Joiners.—This plan brings the two edges of boards true for glueing together, and possesses evident advantages over those in general use. *a*, bed of some hard wood; *bb*, table supported by blocks *ccc*; *d*, a block carefully planed and fitted at right angles to the table. With this board the whole of the plane-iron

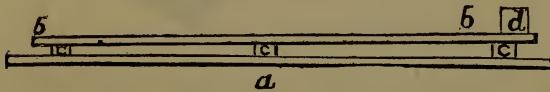

is brought into use, instead of one part only, as in the board usually adopted. Of course the plane-iron would have to be perfectly straight on its edge, otherwise it would bring the edges of the board false.

Waterproof Mortar.—The admixture of coal-dust with mortar renders it impervious to water. This waterproof mortar may be made by mixing two parts of fine cement with one part coal-dust reduced to a very fine powder, and one and a half parts slacked lime; then adding water, so as to produce the desired consistence. Mortar thus made possesses great solidity; but the darkness of its colour is often an obstacle to its use.

Damp on Walls.—A complete cure from damp exuding from a brick wall upon which no plaster, much less paper, would adhere, on account of its having been several times saturated with sea-water, has been effected by using “Italian plaster.” The cost is but little more than that of Portland cement, and may be papered upon forty-eight hours after being used, without any risk of damp or discolouration.

Cleaning Paint.—Dissolve 2 oz. of soda in a quart of hot water, which will make a ready and useful solution for cleaning old painted work preparatory to repainting. The mixture in the above proportions should be used when warm, and the wood-work be afterwards washed with water to remove the remains of the soda.

Door - Spring.

—The following is suggested as a simple spring for a door. It consists of half of a hook-and-eye hinge, fixed in two places on the door-stile, and in one place, near the top, on the facing or architrave. A piece of wire, $\frac{3}{8}$ of an inch in diameter, passes from the lower eye straight through the central one, and is then bent out, so as to pass into the upper eye on the architrave. The action of

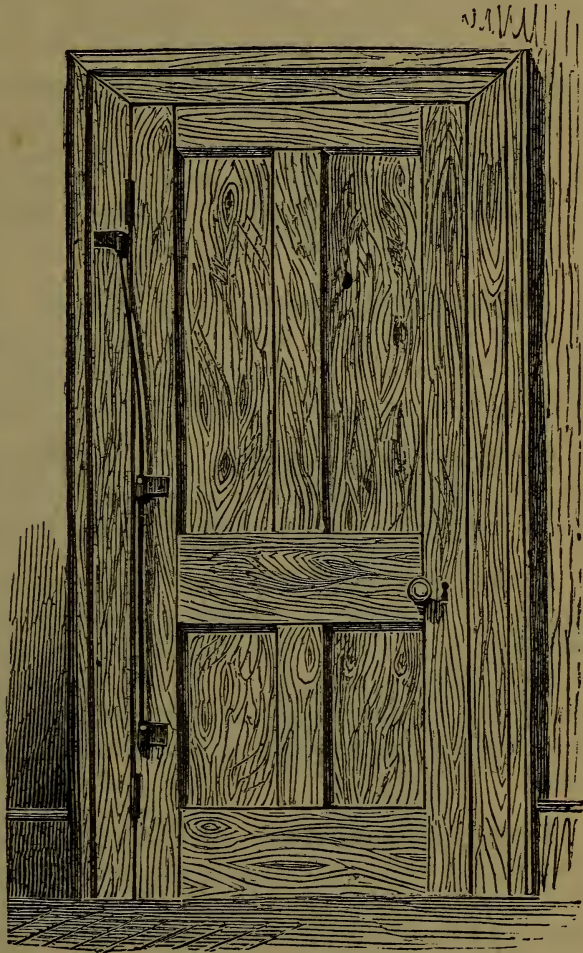

opening the door strains the wire, and the spring acts by its reverting to its former position.

Marble, Imitating.—How to make a stucco mantelpiece look like black marble. Make a mould of wood and line it with plate-glass; and mix stucco with size, to keep it from setting

too fast. The colour ought to be put in among the stucco before mixing; then spread a thin coat on the glass, rub it well to take out the air-bubbles, and fill the mould up with clean stucco before the first sets. After it has set, dip the mould in water, and it will come out easy. So soon as it is dry, dip it into size mixed with black, and then cover with black varnish. Do not touch it with the fingers after it has come out of the mould. Use mineral colours, and be certain that there is no oil in them. Any other kind of marble may, by a little ingenuity, be imitated when the first coat is laid on. A better kind of mould can be made by taking an original and covering it with clean glass, and then pouring wax, such as plasterers use, over the glass.

Architectural Ornaments in Relief.—For making architectural ornaments in relief, a moulding composition is formed of chalk, glue, and paper paste. Even statues have been made with it, the paper aiding the cohesion of the mass.

To Take out Iron Stains.—Mix in a bottle equal quantities of fresh spirit of vitriol and lemon juice, wet the spots, and in a few minutes rub them off with a piece of soft linen.

Anti-Pestilential Vinegar.—Take acetic acid (5°) 900 grammes, camphor in powder 5 grammes, crystallised phenic acid 100 grammes. This combination of three antiputrescents is said to be extremely useful, and for hygienic purposes far superior to “vinegar of the four thieves,” as toilet vinegar was once called. It has been used on board ship to keep cabins sweet.

Preparation of Walls in Tempera.—When it is wished to colour a wall, not retaining the plaster or stone as a ground, the following order must be observed. First mend any broken parts with a mixture of putty and plaster-of-Paris neatly put on with a spatula or palette knife, and smoothed down; then brush over the walls with a size, composed of 1 lb. of good glue dissolved in 1 gallon of hot water, thickened with some red lead, or else with Young’s patent size. Give this sufficient time to dry. Now proceed to make your ground colour, which we will suppose to be what is usually called vellum tint, as follows:—In a large double-sized paint-pot put 3 lbs. of

gilder's whiting, cover it with water, and let it be until it be perfectly broken up and saturated, and the effervescence has subsided. Then pour off the water, and stir with a thick stick until the mass has attained the consistency of dough. Melt Young's patent size not diluted, and pour upon the whiting, stirring well up, and then straining while warm to free from impurities. Let this stand several days in a cool place until it is formed into a weak trembling jelly, so as to be worked with ease with a stiff brush. Before the size is added it may be stained to any tint which is desired by the addition of the proper colour ground in water. It should be observed that all colours in distemper dry lighter than when first applied, so that the only way to secure the requisite tint is to make experiments upon a piece of paper or card until the proper tint is reached. The colour must then be applied to the walls in its cold and jellied state. For this purpose, use a large hog's-hair brush, and work with decision and freedom, taking care not to retouch any portion of the work, but to cover the ground well as you proceed. The wall should be divided by your eye into squares, advancing from one to another in regular succession, and, of course, beginning from above. Unless for some special purpose, your ground should never be pure white, but be stained, however little, with black, blue, ochre, or chrome yellow, to take off the raw appearance; where a coloured ground is needed, proceed in the same way as above described, commencing with a larger or smaller quantity of whiting, and tempering it in the colour to the degree required.

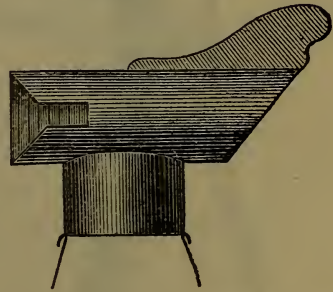
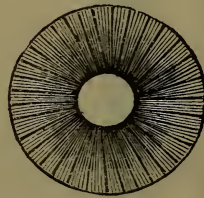
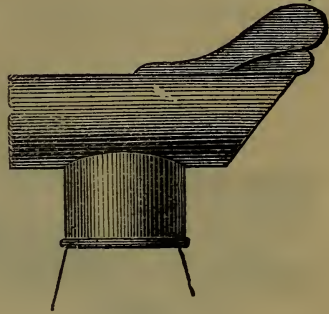

Chimney Cowls.—The above simple arrangement of cowls,

constructed on the principle of the air blowing through, draws up the smoke. They have been largely tried, and have perfectly succeeded.

Cowl for Smoky Chimneys.— Let O be a tube of any length, 9 in. diameter; S also is a tube, and base to O, being 14×9 in.; N is a tube $16 \times 10\frac{1}{2}$ in., upon which is fixed another tube M, at XE; M is a tube through which air passes

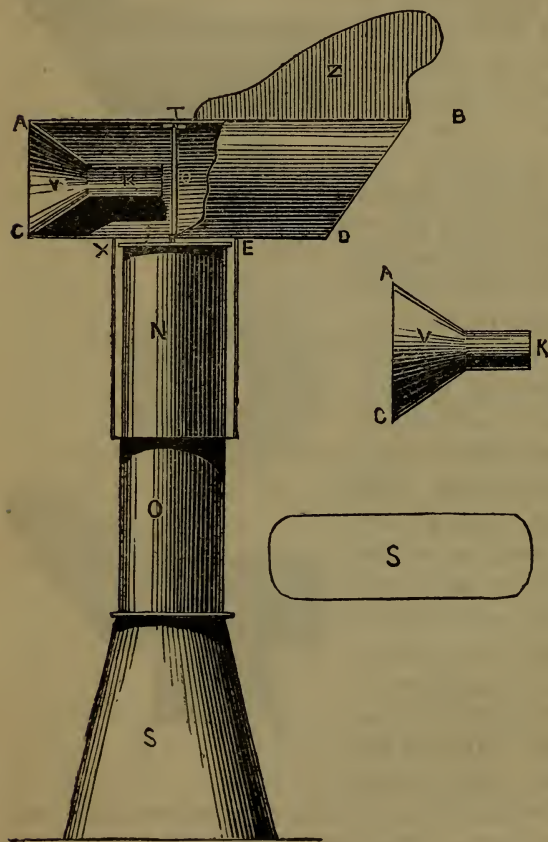

to carry off the smoke. In M *ab* is 20 in., *cd* is 17 in., *ac* is 10 in. diameter, *cx* is 3 in., *ed* is 4 in. V is a funnel-shaped piece of iron, which is fixed at AC, being from the line AC to the opening K, $4\frac{1}{2}$ in., of which K, being a tube, is 2 in. long by $1\frac{1}{2}$ in. diameter, which passes over the mouth of N, $1\frac{1}{2}$ in.; BD is the outlet; O is a rod of iron fixed at the top of O, upon which turns M at the point T. Z is a piece of sheet-iron fixed on M, from T to B, which turns M against the wind, bringing the cone V open to it, by which

the wind, having to pass through it, carries off the smoke at BD.

Stains on Marble, to Remove.—Various plans are adopted for taking iron and ink stains from marble—such as chimney-pieces and wash-hand stands, &c., but the following will be

found most practical :—Mix unslacked lime in very fine powder with strong soap ley ; make it thick, and leave on the marble for more than a week. Then wash off with a thick lather of soft soap, boiled in soft water. Clear off the soap, and brush with a little lime powder, and a fine polish will be the result.

Closet Construction.—Dry earth is no doubt a great deodoriser, and the principle has been adopted with considerable success. It answers under two conditions, that the earth should be thrown down perfectly dry, and kept dry ; but is it so? How many receptacles are commonly emptied into the waste, or, if not, down some open sink? We may suppose that in a town there will be a greater adaptability of water than in the country, whilst in the latter there will probably be attached to the dwelling a strip of garden

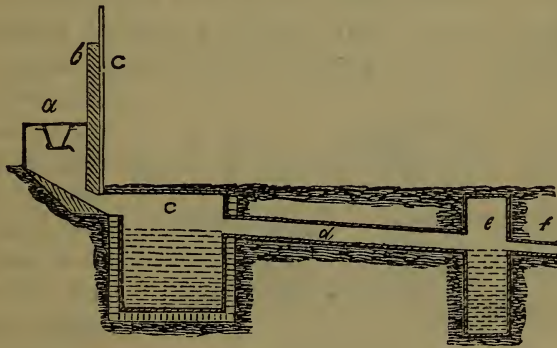

ground into which the manure may be deposited, as in the earth closets. The annexed sketch will illustrate the principle :—*a*, closet pan ; *b*, wall of house ; *c*, a wooden water-spout for carrying down any spare water from the roof, or for letting gases pass away into the open air ; *c*, water-tight tank with flag top, calculated to require emptying of solid contents once in three years ; *d*, an 18-in. drain, running into a second tank *e*, which holds the liquid manure at the bottom of the garden ; *f*, a smaller waste-pipe of some length connected with a drain. The pan is a simply-made affair of sheet zinc painted, with a rim turned over at the top, and a bottom on hinge to balance about a quart of water or so. Over the rim comes a false seat, and all is air-tight. The rim is embedded

in putty. After use a small quantity of water is poured down with a can; but where water from the main can be procured, there would be no difficulty in adjusting a common pipe to the side of the basin, with an ordinary tap inserted in the length of pipe within reach. With this principle there is not the slightest unpleasantness.

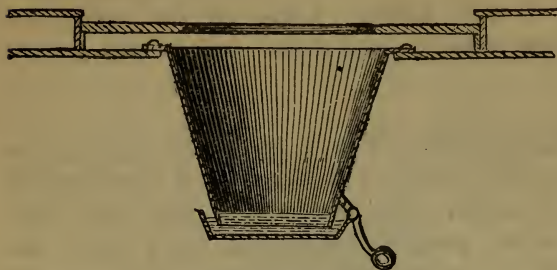

Ventilation.—*A simple way of ventilating a room that has a chimney in it is the following:*—Make an opening in the chimney over the fireplace, and as near the ceiling as possible, about 9 in. by 2½ in., then procure a piece of perforated zinc, 10 in. by 3½ in., and a piece of oiled silk or calico 9 in. by 3

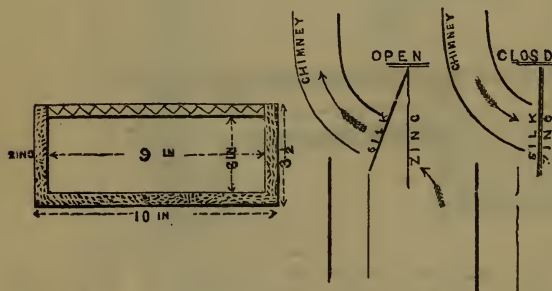

in.; fasten the silk or calico to one edge of the zinc by sewing it through the holes; it will then hang loose on the zinc as on a hinge, but it will not reach the ends or bottom edge by half an inch; now

fix the zinc over the hole, with the flap inside, not in the room, and with the edge that is secured uppermost. A strip of paper bordering may be posted on the wall, and partly on the place, to hold it. The up-draft will blow the silk back, but the down-draft of the chimney will close it.

Cheap and Effective Filter.—Procure one small, low, but broad tree-pot, and two very large ones, both of a size; also a large deep water-pot or tub, and a supply-cask or tub; then get five or six feet of gutta-percha piping, and two small pieces of the best and finest sponge, and close up the holes in the

large tree-pots tightly with the sponges. Place one of the tree-pots within the other, so that the sponges do not touch each other; this being done, and all in readiness prepared, the sand, pounded glass, or charcoal being thoroughly washed clean from dirt or dust, first put the small tree-pot into the water-pot (it being previously raised upon some bricks), and fill up the space between the sides of each, to the tree-pot brim, with sand, pounded glass, or charcoal broken small. Now put the two large tree-pots together into the water-pot also, to rest upon the small tree-pot, and again fill up with sand between the outer tree-pot and the water-pot; then pour water on the sand all round, so that it may find its bed or level, and repeat the sand and water until the level of the sand be near the top of the water-pot. You may now put one end of the tube or pipe through a hole made in the upper part of the supply-cask, so as to nearly reach the bottom; then draw up the water into the pipe with the mouth, keeping the end depressed, and the syphon will be in action, placing the other end in the water-pot. Your filter being now made,

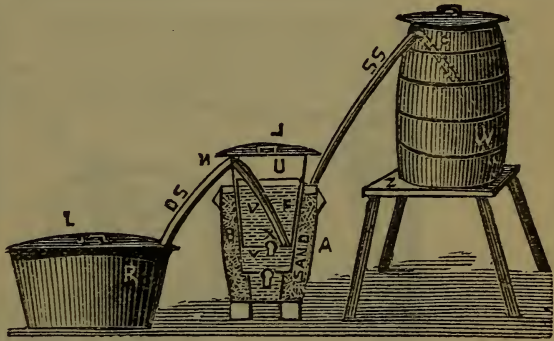

you will soon obtain clear water from the upper tree-pot, which you can lead out or draw off, which is preferable, with another short syphon, into a receiver.

Having once had need of a filter we adopted a similar plan, with charcoal between the two large tree-pots, with a piece of flannel surrounding the sides and bottom of the upper tree-pot, minus the small pot and sand; but in time the flannel is apt to rot and become unwholesome.

C, the supply-cask; SS, the supply-syphon; Z, the stool of elevation for syphon action; A, the water-pot; UV, the large tree-pots; FW, filtered water; W, water; SS, sand; R, receiver of filtered water; DS, discharge syphon; LLL, lids and sponges; KK, bricks; N, notch made in tree-pot for pipe; U, upper tree-pot; V, the lower one. As the filtered water has

to ascend, the action of this filter is preferable to those wherein it has to descend.

Hat and Cloak Peg Frames.—Here is a portable hat and cloak peg frame, made either of mahogany or deal, framed together, about 3 feet long by 6 in. wide; the framing is 1 in. wide, by $\frac{3}{4}$ in. thick; the pegs or hooks, hinged between on wire pins, are of the same thickness as framing; the letters A show the rails of framing, and it is hung with two rings as shown. It is suitable for either halls, backs of doors, or tents, and can be removed at pleasure. It can be made of any length, and the hooks fold flat as shown.



Alarums.—From among the many ingenious contrivances

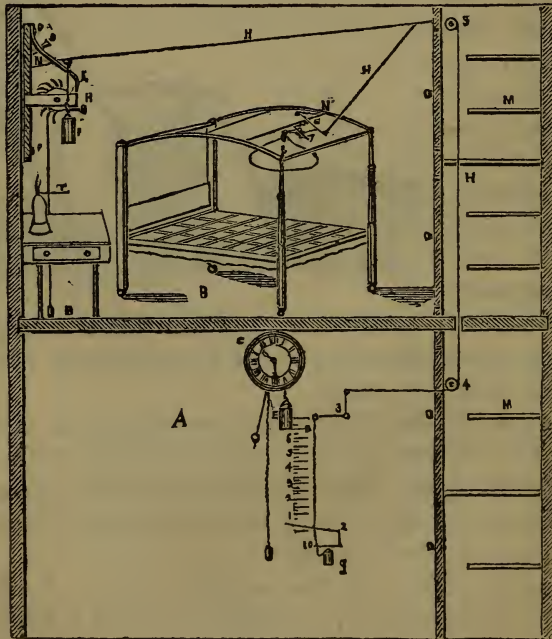

known as "Early Risers' Friends," "Mechanics' Friends," &c., we select the above:—

1. A is the kitchen, B the bedroom, and C the clock. It

does not matter if your clock has only one weight ; when the clock is in action, watch it for one hour ; notice how much the weight lowers in that time ; then divide it into a scale of halves and quarters ; after which, mark on the wall the hours, as shown at D. When going to bed, consider how many hours you wish to sleep. Example : Supposing it to be half-past ten, and you wish to rise at five o'clock, raise the weight E to half-past six. At five o'clock in the morning the weight E will press on lever F, down drops weight G, pulling string HHH, and down drops a heavy parcel on the legs of the sleeper. At the same time that weight I is lowering, round goes the cog-wheel K, pressing against the tin-spring L, which makes a great noise. Where there may chance to be a cupboard, as at MM, the string can go into it out of sight. NN is a short piece of elastic placed to keep the string on pulleys, when the weight G is suspended at 1, 2, 3, 4, 5, 6, 7, 8. Use round nails for wires to work on, No. 9 screw to slack or press the tin on wheel, OO nails to secure alarum to wall, P balance-weight for I, and to keep string on pulley Q. In addition to the above, turn the light nearly out of the lamp at night, so that weight (I) can put full light on in the morning by lowering lever T.

2. A, lamp ; B, spring holding socket for match ; C, centre tumbler, connecting the spring to the match holder ; D, lever ; E, pinion holding the spring, having a rough surface for the purpose of igniting the match ; F, whistle ; G, coffee can.

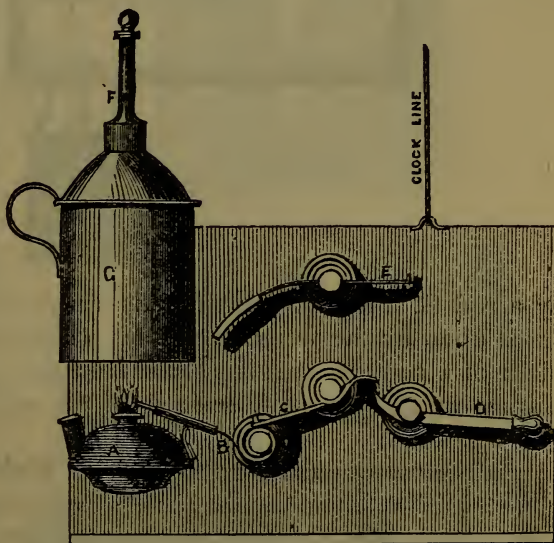

3. The following is an apparatus attached to an ordinary alarum clock. It has been practically tried, and found satisfactory. It is enclosed in a frame or case, and suspended

against a wall, just below the ceiling, so as to give the weight plenty of room to run down. AB, arbor, bearing a fly-wheel C, in which are inserted, in a radial direction, two hammers DE; these impinge on the inner edge of a gong F, suspended

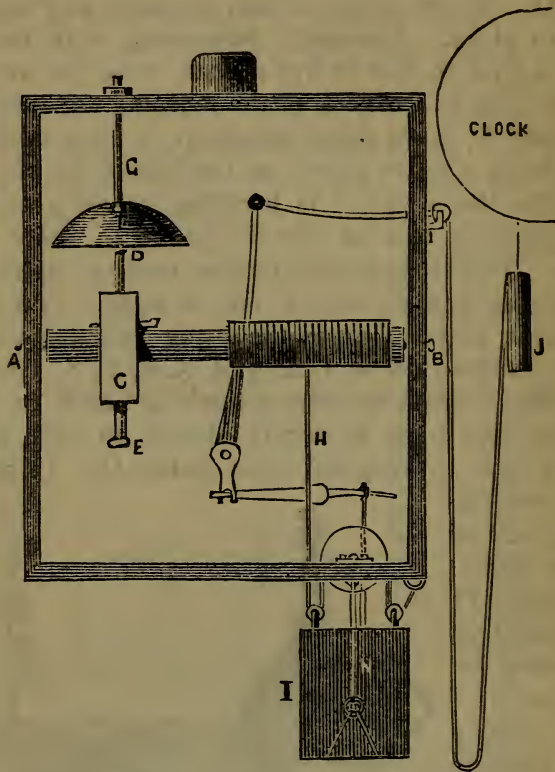

by a rod G. Round the arbor is rolled the cord H, which is acted upon by the weight I. This weight is suspended in the bight of a cord N, and is released on the running down of the alarum-weight J, as will be seen by the engraving.

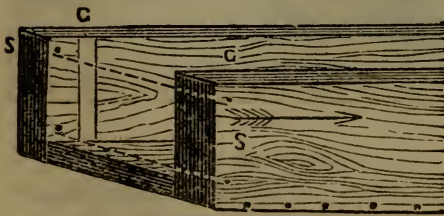

Water-Tight Cisterns.

—Construct your cistern in the usual mode—viz., the sides nailed to the ends. It can scarcely be made tight by any paint or cement where the grain of the wood of end and side, or end and bottom, of the tank have a differ-

ent direction, and are fixed together with nails. The pieces so joined are constantly sliding one on the other, the one swelling and contracting, and the other not—in fact, they cannot agree. The following arrangement will obviate this :—Secure sides to bottom, which should both have the grain of wood in direction of the arrow. Fit the end (the edges of which should be like those of a cask-head) into groove G, and nail the bottom of tank only to the lower edge of the end-pieces, the end-piece to have the grain up and down. The ends of sides to be drawn together by two or more screw bolts and nuts SS. Thus formed, when the sides swell, they have liberty by sliding on the edge of ends to expand or contract. If a tank thus made leak, let some pitch be melted into the seams with a heated ploughshare, or any convenient piece of iron, the wood being first thoroughly dry.

Improved Way of Storing Rain-Water.—When casks are used to catch rain-water, holes are often cut in the higher ones

to let the water fall into the lower. A better way would be to take a piece of gas-pipe, bend it into the shape of the letter U, and fill it with water, to exclude the air. Put one end into each tub, the one being full, the other empty. They will soon come to a level. In this way a number of vessels may be set all upon the level, without cutting or boring holes.



Garden Engine.—BCEF_H is a force-pump together with an air-vessel; BB is a barrel about 2 in. diameter by 10 in. long, made of copper or brass (a piece of telescope tube would

answer very well) screwed into the stand (iron) CDEF; H is an air-vessel; I and J are the suction and delivery valves; F is the delivery-pipe, to which should be attached a piece of indiarubber hose about $\frac{5}{8}$ ths of an inch in diameter, at the end of which is a jet or nose. The piston is formed of two leather cups, the top one inverted, which are held in their proper position by two collars to the rod. Dirt, &c., is prevented from entering the pump by means of a piece of iron gauze represented by dots beneath the nose DE.

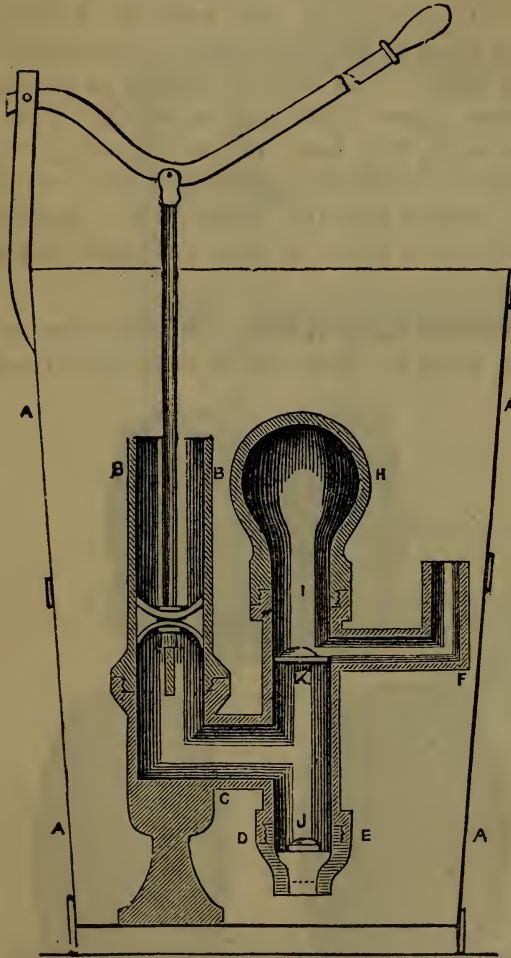

As soon as the handle is raised, the water enters the pump through the valve J, which closes when the lever is depressed. The water is then forced into the air-vessel through the valve I, which prevents its return. The air in H again being compressed, as soon as the power is removed, forces the water very rapidly through the delivery-pipe, &c. Should the pail AAAA not be required, the foot

of stand must be larger, a piece of hose being attached to DE, and a stuffing-box placed at the top of the pump, to prevent the escape of any water that might pass the plunger.

Double-Action Pump for Garden Engine.—By the sketch

below, it will be seen that the water is kept constantly in a stream both with the ascent and descent of the piston. The sketch is so simple as to require no further explanation.

Transfer Paper.—Transfer paper may be prepared thus:—

Make a mucilage with $\frac{1}{2}$ oz. of gum tragacanth; strain; add 1 oz. of glue and $\frac{1}{2}$ oz. of gamboge. Mix French chalk 4 oz., old Paris plaster $\frac{1}{2}$ oz., starch 1 oz.; run them through a sieve, grind with the mixed mucilage, add water to reduce to the consistence of oil, and apply it with a brush to thin-sized paper. The drawing made on this prepared side of the paper is wetted at the back and

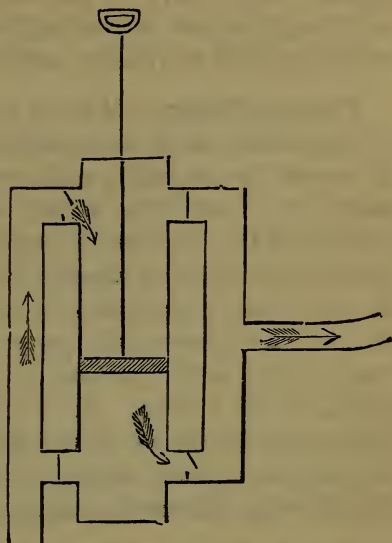

placed on the stone, which is warmed to 125° Fahr.; the whole is then strongly pressed in the lithographic press, and the stone receives the impression, which may be printed from as usual. When two impressions are required, a red composition is made of wax 2 parts, soap 1 part, and vermilion to colour, all melted in a saucepan, and ground with water to the consistence of cream. This is spread thinly on the second stone, an impression from the first stone is next applied, and the second drawing is thus made to correspond with the first exactly. If in printing the drawing becomes smutty, mix equal parts of water, olive oil, and oil of turpentine; shake till they froth, wet the stone, throw this froth on it, and rub it with a soft sponge. The printing ink will be dissolved, and the drawing will almost disappear; but, on rolling it, it reappears as clear as at first. When the stone is laid by for future use, a preserving ink is applied, to prevent the surface printing ink becoming too hard. Thick varnish of linseed oil 2 parts, tallow 4 parts, wax and Venice turpentine, of each 1 part; melt; add by degrees lamp-black 4 parts, mix thoroughly, and preserve in a tin case. This must be rolled on the stone each time before laying it aside for future use. When the whole of the impressions are completed,

and the stones required for other drawings, two of the stones are laid face to face, and ground with sand and water until the surfaces are clear. They are, finally, more or less polished with pumicestone, according to the required fineness, and are then prepared to receive other drawings.

Tracing-Paper.—Having prepared a mixture of equal parts of turpentine and gum-mastic, spread out a number of sheets of crown tissue-paper, one over the other; then brush the top sheet over with the above mixture, and hang it up to dry. Proceed with the rest in same manner. As the under sheets absorb some of the varnish laid on those above them, less will be used than if each was brushed separately. This varnish for tracing-paper leaves the paper quite light and transparent. It may readily be written on, and drawings traced with a pen are permanently visible. It is used by learners to draw outlines. The paper is placed on the drawing, which is clearly seen, and an outline is made, taking care to hold the tracing-paper steady. In this way elaborate drawings are easily copied.

Oiling Tissue-Paper.—Lay it on a flat surface, and rub linseed oil over it with a piece of cotton wool or a brush, and hang it up to dry.

Stencil-Plates.—For cutting stencil-plates use a mixture of 3 parts nitric acid and 1 part water. After heating the plate slightly, prepare the ground for etching by rubbing it over with common heel-ball. The back of the plate should be oiled, so that the cutting may be clean.

Drawing-Board, to Black.—Take $\frac{1}{2}$ lb. of lampblack, and put it on a fire-shovel over a clear fire until it is red hot; then take it off, and, when cool, pound it very fine, and mix it with a pint of turpentine. This should be laid on with a size-brush. If the board is new, before using the above it will be necessary to give it one or two coats of lampblack mixed with boiled oil.

Map Colouring.—Ordinary water-colour paints may be used, preferring the moist variety, and those not opaque, such as gamboge, carmine, indigo, or Prussian blue. With these all the colours required may be formed. Wet the sheets with clean water first, and as soon as the moisture has disappeared from the surface, apply a thin wash of the colour with a tolerably full brush, passing over the surface quickly. Commence

at the top and at his left hand, coming down to the bottom right hand. Use blotting-paper to dry any superabundance of colour.

Pencil Drawings, to Preserve.—Apply a thin wash of isinglass, which will prevent rubbing off either of black lead, or of hard black chalk.

Pencil Writing, Indelible.—Some years ago the Society of Arts offered a premium for an indelible pencil to write on common paper, but nothing satisfactory was produced. Any pencil writing or drawing may, however, be rendered as indelible as if performed with ink by the following simple process :—Lay the writing or drawing in a shallow dish, and pour skimmed milk upon it. Any spots not wet at first may have the milk placed over them lightly with a feather. When the paper is all wet over with the milk, take it up and let the milk drain off, and whip off with the feather the drops which collect on the lower edge. Dry carefully, and it will be found to be so perfectly indelible as not to be removed even with indiarubber.

Picture - Cleaning.—The most simple application for oil pictures is water and plenty of it. If the coats of varnish are very thick, the scraper may remove a good deal. Spirits of wine and turpentine may be applied ; but the scraper, spirits of wine and turpentine, will attack the paint as well as varnish, and the art of picture-cleaning is to stop action before you arrive at the paint. Water will stop further action of the spirits. Experimentalize only on a corner or an unimportant part of a picture. Many good and valuable pictures have been rendered worthless by the process of what is usually called cleaning, particularly under the infliction of spirits of wine, turpentine, home-made varnish, &c. If the picture be an old one, it is usual to begin by rubbing off the old varnish, which is done with the fingers, rubbing gently and evenly in small circles over the whole picture, beginning with a little dust on the fingers, after which the light powder—the remains of the gum of the old varnish—will soon appear. Care must be taken not to touch the colour of the picture. Then wash with clear water, and when quite dry, varnish. It is preferable in all respects to buy varnish at the artist's colour-shops. If there is not any old varnish on the old picture, first wash the picture

with warm rain-water, using a soft sponge, and then carefully with a lukewarm solution of a quarter pound of soft soap in a quart of rain-water.

Varnishes for Prints and Water-Colour Drawings.—The printing must be thoroughly dry. Size made by boiling an ounce of best isinglass in a pint of water should then be applied quickly to the surface. This may be done in two ways, the latter being preferable. First brush the size over the surface of the picture rapidly with a broad camel's-hair brush; second, having poured the solution into a flat dish, pass the drawing quickly through the fluid, so that the whole of both surfaces may be thoroughly wetted. Lay the drawing carefully upon a flat board to dry; any colourless varnish may then be applied. If isinglass cannot be procured, clear gum-water will answer almost as well.

A good and cheap Varnish for general use, and one which dries in a very short time, may be made of the best wood naphtha 1 pint, gum shellac 2 oz., gum sandarac 2 oz.; pound the ingredients in a mortar, and pour on the naphtha, shaking it up often. When dissolved, filter through fine muslin, and the varnish will then be fit for use. If too thick, add more naphtha.

Another Varnish, fitted for prints or drawings, is the following:—Give the article one or two coats of gum arabic, dissolved in water, about 2 oz. to a pint; a coat of crystal varnish will complete the operation. The crystal varnish may be purchased at any of the oil and colour shops. Turpentine varnish is often used in lieu of crystal, and is much cheaper. Fine parchment size, or isinglass, will be found preferable to gum-water. The best varnish is clear pale copal, dissolved in rectified spirit, which is easily done by heat. A small quantity of shellac will harden the varnish, but it communicates a brownish tinge. A varnish composed of shellac alone, dissolved in spirit, is so hard, that if a coat of it be laid upon a card, it may be written upon with a pen and ink, and rubbed out again with a sponge, without leaving any perceptible trace.

Another Varnish.—Balsam of copaiba 4 parts, powdered copal 1 part. Mix, and keep it in a close vessel at a heat of 150° Fahr., until the gum is dissolved; then thin it with turpentine.

Size for Prints or Drawings before Colouring.—Best pale

glue and white soap, of each 2 oz., hot water 30 oz. ; dissolve, and add powdered alum 1 oz.

Painters' Cream.—Painters who have long intervals between their periods of labour are accustomed to cover the portions painted with a preparation which preserves the freshness of the colours, and which can be removed when they resume their work. This is the preparation :—Take of clear nut oil 3 oz. ; mastic in tears, pulverized, $\frac{1}{2}$ oz. ; sal saturni, in powder, acetate of lead, $\frac{3}{4}$ oz. Dissolve the mastic in oil over a steady fire, and pour the mixture into a marble mortar over the pounded salt of lead ; stir it with a wooden pestle, and add water in small quantities till the matter assumes the appearance and consistence of cream, and refuses to admit more water.

Modelling.—Rice flour, mixed thick with a little cold water, and warmed over a fire, may be moulded into busts, figures, bas-reliefs, ornaments, &c., very readily. When dry and hard, images thus formed may be polished, and will be found very durable.

Gypsum — Plaster of Paris. — This substance possesses some peculiar properties. It consists of sulphuric acid, lime, and water ; its composition, or rather the proportion of its component parts, being similar to that of alabaster. Its abundance in the tertiary basins around Paris has given it the name of plaster of Paris. It is found in Nova Scotia in profusion in the lower carboniferous rocks. It is produced by the decomposition of iron pyrites and limestone in juxtaposition. It is formed wherever sulphuric acid is generated, and comes in contact with carbonate of lime. Crystallized gypsum is called selenite, and the ancient Romans are said to have used it as glass. It is often coloured by oxide of iron to grey, brown, red, yellow, and even black. It is used extensively for making plaster casts, and for stucco. It is prepared for these purposes by calcining, which is simply heating it in kilns or kettles until the water is expelled. It is then a fine powder, like wheat flour, and to be used, must have the water which it previously held returned to it. To preserve it from contracting the moisture in the atmosphere, it should be kept as nearly air-tight as possible. Much of the plaster or gypsum sold in the market

is deteriorated by careless handling and packing. When mixed with water, it "sets" quickly, and no time should be lost between the mixture of the gypsum and the taking of the cast. Of late years it has been a favourite substance with dentists in taking casts of mouths to which teeth were to be fitted. We know of no way by which this substance, being once used, can be brought to its original state. It is used to some extent in glazing porcelain; but it is more largely used as a fertilizer of soils than for any other purpose. Containing a large proportion of sulphate of lime, it is extensively used as a manure. It is excellent for grass of all kinds, furnishing just the nutriment needed.

Fictile Ivory.—This ivory is prepared by intimately mixing and passing through a fine sieve superfine plaster of Paris and Italian yellow ochres—half an ounce of the latter to every pound of the former, and then forming a plaster cast of these ingredients in the usual way. This cast is first dried in the open air, and then carefully in an oven; after which it is soaked for 15 minutes in a mixture consisting of equal parts white wax, spermacetti, and stearine, heated a little above the melting-point. When removed from this, the cast is allowed to drain, and before it is cold any excess of the wax, &c., which may remain in the crevices, is brushed off by means of a painter's sash-tool; and as soon as it is quite cold, it is polished with a tuft of cotton wool.

Plastic Moulding (*Parkes' Patent*).—To make about 1 lb. of this compo, melt together $\frac{1}{2}$ lb. each of wax and deer's fat; then dissolve 19 or 20 grains of phosphorus in 300 grains of bisulphide of carbon. Keep the wax mixture barely melted, and add the phosphorus solution slowly to it. Briskly stir the fat while pouring it in at the bottom of the melted mixture by means of a vessel with a long spout to prevent it inflaming. It is highly dangerous to spill the phosphorus compo where it can come in contact with wood, paper, rags, &c., as after a lapse of even many hours they will often burst into flame.

Vegetables, Insects, Small Birds, Frogs, Fish, &c., Cast in Plaster Moulds.—Provide a trough of boards, nailed together so as not to let the water run through the joints; suspend in the trough, by thread or Holland twine, in several

places, the vegetable, plant, insect, &c., which you would cast, which, being performed, mix 4 parts of plaster of Paris, and 2 parts of fine brick-dust with common water, to the consistence of cream, and with this cover the thing intended to be cast, observing not to distort it by any means from its natural position. When you have filled your trough, let it harden by placing it near the fire by degrees till you can make it red hot; then let it cool, and with a pair of bellows blow and shake as much of the ashes out of the mould as you can. You must now put a small quantity of quicksilver into the mould, and shake it, in order to loosen every part of the ashes therein; also to make a passage through where the strings were tied, in order to let the air out when you pour in your metal.

Metal for the above Work.—Take of grain tin 6 oz., bismuth 2 oz., and lead 3 oz. Melt them together in an iron ladle, and you may cast in the above mould to your satisfaction. You may combine the above ingredients in such proportions as to compose a metal that will melt in boiling water, thus—Sir Isaac Newton's fusible metal is composed of 8 parts bismuth, 5 parts lead, and 3 parts tin; this alloy melts at 212° . Rose's alloy is still more fusible; it is 2 parts bismuth, 1 part lead, and 1 tin, and melts at 201° . Dr Dalton's fusible alloy—3 parts tin, 5 parts lead, $10\frac{1}{2}$ parts bismuth—melts at 197° . The addition of a little mercury makes it more fusible, and fits it to be used as a coating to the insides of glass globes.

Varnishing Plaster Casts.—Plaster casts can be varnished by a mixture of soap and white wax in boiling water. A $\frac{1}{4}$ oz. of soap is dissolved in a pint of water, and an equal quantity of wax afterwards incorporated. The cast is dipped in this liquid, and, after drying a week, is polished by rubbing with soft linen, producing a polish like marble. If to be exposed to the weather, saturate the casts with linseed oil, mixed with wax, or resin may be combined. In casting the plaster, use spring-water and gum arabic.

To Print on Canvas.—Prepare the canvas by washing it over with a solution of bicarbonate of soda in water, and rub it until it is evenly wet. Wash with water to remove the soda, and then lay a piece of albumen paper, of the size you wish to make the print, face down upon it, and rub it well to secure contact all over. Lift up the paper and remove the bubbles,

if there should be any, with a brush. After drying, coagulate the albumen by pouring on some strong alcohol; dry again, silver with a 40-grain silver solution, slightly acid; print, and fix in hypo.

Cyanide of Silver.—Break up an old silver coin, say 6d.; put it into a porcelain cup, and cover it with nitric acid undiluted; set it on a fire-shovel over a slow fire, or make it warm by any convenient means, and the silver will soon dissolve; add acid occasionally, if necessary; when dissolved, fill the cup nearly full with clean rain-water, and let it settle for a few minutes. Pour off the clear liquor into a pint glass tumbler or jug, add a tablespoonful of clean common salt, chloride of silver will be the result. Pour off the clear liquor (which may be thrown away); add water to the precipitate, and agitate it well with a glass rod, but by no means with a metal one; pour away the liquor as before; wash again; by these means the salt will be washed out. Now dissolve $\frac{1}{2}$ oz. of cyanide potassium in a half gill of rain-water warm; when dissolved, and the liquor cold, add it gradually to the dissolved silver, and a good plating liquid, consisting of the double cyanides of silver and potassium, will be the result. To use the solution, clean the article well, immerse in the solution in contact with a small piece of clean zinc. With nitrate of silver he can proceed thus: Dissolve the crystals in water, add to the solution gradually the solution of potassium, till a precipitate has fallen, then add more cyanide until that precipitate is redissolved,—a much cleaner way than the others, and something purer too, but not so cheap.

Instantaneous Photography.—Herr Metzger is of opinion that success in instantaneous photographs depends more upon the excellence of the apparatus and chemicals employed, and rapidity of manipulation, than on the practice of any particular theory or process. Of the many descriptions of collodion, that prepared according to Dr Liesegang's formula appears to him best suited for instantaneous photography; for although (he says), I have been successful in obtaining good results with mixed collodions, I prefer to use a material freshly prepared, together with a neutral 10 per cent. silver bath. For developing I employ the following formula, adding as much alcohol as

may be necessary to make the solution flow evenly over the plate, viz. :—

Water,	100	grains.
Sulphate of iron,	5	„
Acetic acid,	3	„

My negatives are intensified with pyrogallic acid, which is used very carefully, in order that the harmony of the pictures may not be destroyed. The plate should be exposed as soon as possible after its exit from the silver bath, and developed immediately after exposure; the object to be photographed must be lighted as strongly as possible; and if direct sunlight is not present, all false lights and reflections are to be carefully avoided. March and October are the most favourable months for instantaneous photography.

Instantaneous Pictures by Artificial Light.—Mr Thomas Skaife has patented a process to obtain an instantaneous flash of artificial light for the production of small portraits. The specification is as follows :—These improvements relate to the construction of an apparatus for igniting and burning any powder or other composition either in a solid or liquid state, the flame or flash of which, being sufficiently actinic, is applied for the production of photographic pictures. For this purpose the said apparatus consists of a platform of metal or other incombustible substance perforated with one or more touch-holes fixed, attached to, or supported by, a spring or springs in such a manner as to permit of its being easily vibrated or thrown into a tremulous motion by the touch of the finger or other appliance. Connected with or attached to the platform is a parabolic or other reflector pierced with a groove, through which communication is made with one end of the platform, by which it may be touched or struck, so that by means of the aforesaid springs it may suddenly vibrate. The deflagrating powder or other explosive actinic substance, being placed or strewn upon the perforated platform, is suddenly brought into contact with a light from an ordinary spirit-lamp, or such like substance, preferably placed underneath it; at the same instant the platform, being thrown into vibration, communicates this motion to the particles of the powder or other substance to be ignited, the result of which action is that every particle explodes

or is ignited simultaneously, and producing a flash of light which, acting upon a sensitized plate in an ordinary camera, produces the picture of any object placed before it. When the picture of a near object is required, the powder may be placed over a touch-hole; if the picture of a distant object is to be taken, then the powder may be distributed over the platform and over several touch-holes, to all of which the light may be applied. Having now described the nature of my invention, and the principles by which it is carried out in practice, I wish it understood that what I claim and desire secured to me by the before in part recited letters patent is, the use of a vibrating platform or table with or without a reflecting mirror, for the purpose of producing, by means of vibration among its particles, an instantaneous combustion of any actinic powder or other deflagrating or easily flammable substance, when used for the purpose of obtaining photographic pictures substantially as herewithin described and set forth.

Photographometer.—This apparatus is intended to record the angular position of objects situated around a given point. It is automative, and very simple. The record is made by photography, and the camera used, with the exception of certain additions, does not differ much from the ordinary kind. The objective, which is that usually employed by photographers, is mounted vertically on a circular platform capable of rotating, by means of clockwork, in a horizontal plane. The picture is formed, not in a vertical plane, as in ordinary cases, but in a horizontal; and therefore the rays, passing in through the objective, are deflected 90° by means of a reflecting prism, so as to fall on the sensitive surface, which is collodionized glass, and is placed in such a way that its centre corresponds with the point at which the centre point of the diaphragm would be represented. To prevent a number of confused images, superimposed on each other, being formed during the rotation of the objective, an opaque screen, having a narrow oblong opening, the medial line of which passes through the axis of rotation, is placed over the whole of the sensitized surface, and revolves along with the objective. The result of this arrangement is the production on the sensitized plate of images of the different points that lie around the observer; the angles formed by lines joining the centre of the plate, and the different objects being

exactly the same as those formed by lines joining the centre of the instrument and the objects themselves. The position of the objects thus accurately obtained may be transferred to paper, &c., in the ordinary way. As different velocities of rotation may be suited to different purposes, three different velocities may be obtained by means of a regulator. And as it may be wished to mark down only certain points of the panorama, an arrangement is made which secures the attainment of this object. Should it be desired to observe not different points, but successive changes at the same point, the objective and the screen are disconnected, so that only the latter revolves; the successive appearances at the same point are then recorded in succession in a circle round the sensitized plate.

Hyposulphite of Ammonia for Fixing.—The question has repeatedly been asked as to whether the use of hyposulphite of ammonia might not be found more efficient in fixing than that of the soda salt. In some of Sir John Herschel's earliest experiments with the hyposulphites as solvents for silver salts, he used hyposulphite of ammonia, but we have no record of its use for photographic purposes. Mr T. H. Redin, a skilful amateur photographer, has made some good prints fixed with hyposulphite of ammonia. It was used in the same manner as the soda salt. There is good reason to believe it will be valuable in securing more perfect fixation than has hitherto been secured, and will so be conducive to permanency. Hyposulphite of soda does not perfectly dissolve albuminate of silver, but leaves some portion of the silver salt in the whites of the print. The new salt effects the perfect removal of the silver.

Recovering Silver.—Let the amateur put his powder, sand and all, into a glass or earthenware jar, and pour over it some aquafortis, diluted with seven times its bulk of water, considerably more than enough to cover the sand, &c. Stir well with a glass rod or piece of charcoal or wood, so long as any fumes are given off. Allow it to settle, and pour off the clear; what remains as sediment may be thrown out, as it is only sand and dirt, the silver and copper being dissolved out. To the blue liquid portion add muriatic acid (spirit of salt) so long as a white curdy precipitate is formed and falls. Pour off the liquid portion, and throw it away as useless. Wash the precipitate

frequently with water until it is tasteless, or is in no way acid, without losing any. Then dry it at a low temperature unexposed to light. The remaining powder is tolerably pure chloride of silver. If it is desired to obtain metallic silver from this, the chloride, the following process is both elegant and extremely simple :—Put the chloride of silver into a glass tumbler with some slips or chippings of thin sheet zinc. Then add some oil of vitriol diluted with seven times its bulk of water, sufficient to saturate and cover the contents of the glass, stir with a slip of sheet zinc until the contents assume a homogeneous grey colour. Remove the clippings of zinc, and wash the remaining powder with water until it ceases to be acid ; dry it, and what remains is chemically pure metallic silver. If wanted in a solid condition, fuse it in a crucible with a little powdered charcoal, when it will assume the brilliant white metallic lustre characteristic of the pure metal. If he wishes for the alloyed metal he has lost, he may get it in a much simpler way. Let him precipitate the powder into a shallow glass or earthenware vessel full of water. The metal being the heaviest will fall to the bottom first. By removing the superficial layer of sand and dirt, and repeating the process several times, he will obtain the lost metal composed most likely of a mixture of silver and copper.

Silver, How to Save.—The waste silver is an item of considerable importance to every photographer, and an apparatus for saving it must therefore be useful. A “ Practical Photographer ” thus explains his plan :—I made my sink with more dip or inclination from horizontal than is usual, in order to have the water flow off more rapidly ; then in the lowest corner I inserted two lead pipes close together, one of them leading into the waste drain, the other into a tank or barrel under the sink, which should be of sufficient size to contain the washings of one day’s work. These vents can be opened or closed at pleasure, by moving a lever attached in such a manner as to close one while it opens the other, and *vice versa* ; or the pipe may be simply closed with a cork, which can be shifted from one to the other as is desired. This is not so convenient a method as the other. Whenever the washings contain silver or gold, I allow them to pass into my tank ; but when worthless, by shifting my lever I let them run to waste. I have a

faucet inserted into the tank about one foot from the bottom, and after the day's work is over, I draw off two or three gallons of the contents of the tank, and add to it sufficient cream of lime or whitewash to neutralise the whole, and pour it back. If this operation is rightly managed, the water can be drawn from the tank perfectly clear after standing over night. The cream of lime is best prepared by selecting the purest lumps of quicklime, and slacking them carefully with boiling water (sufficient water should be added, and the mass constantly stirred, to prevent its getting too hot or dry in spots, in which case it will be lumpy and coarse); after cooling, it should be of the consistence of thick cream, and may be kept in an earthen or stone jar for a long time, if properly covered, so as to protect it from the carbonic acid of the air. It will be found very convenient for many purposes. As fast as the tank fills up with sediment to the faucet, I dip it out and dry it, and reduce the silver by any method that may be preferred. The operations are easy and economical, and the saving of silver considerable.

To use Old Baths, and Save the Silver.—A correspondent of the *American Journal of Photography* says—“For several months past I have been using an old silver bath for silvering albumen paper. It had been used a long time, and was in such a condition that it would not work without considerable trouble, so I added pure water sufficient to precipitate the iodide; then, after filtering, I added silver in crystals until the solution was strong enough for silvering paper; then a sufficient quantity of aqua ammonia. It seems to give as good results as to use the crystals. There is more economy in this process than in ‘doctoring up’ an old bath; for any one who makes photographs uses more silver for silvering paper than for any other purpose, and by this process old baths that ‘will not work’ can be used up.”

Nitrate of Silver Bath for Negatives, Preparation and Management of.—This bath, which exercises such an important influence on the quality of photographs, is simply composed of nitrate of silver dissolved in water. When dissolved, it should be nearly neutral, the deviation from neutrality being in favour of acidity. In much of the nitrate of silver of commerce there is imprisoned a certain quantity of nitric acid, which,

when the crystals are dissolved in distilled water, renders the solution acid in too great a degree. If the ordinary commercial crystals be employed, crush them into a coarse powder and apply heat, which drives off the excess of nitric acid. Then dissolve them in distilled water, in the proportion of 35 grains of the crystals to 1 oz. of water. Use only half of the water intended to be added, and then add (previously dissolved in a small quantity of water) about 3 grains of iodide of potassium. The iodide of silver formed by this addition will be dissolved, after which add the remaining half of the water, and then filter. With most of the samples of nitrate of silver no other preparation is required. If, however, the picture taken prove deficient in clearness, add one or two drops of a very diluted solution of nitric acid, composed of half a drachm of the acid in an ounce of distilled water. This for a bath of 12 or 14 ounces will, in most instances, prove sufficient. An efficient method of making a neutral bath is to dissolve $1\frac{1}{4}$ oz. of crystals of nitrate of silver in 4 oz. of distilled water, and, when dissolved, to add to it 4 grains of iodide of potassium dissolved in a drachm of water; shake, and add 16 oz. of distilled water. Now add to this a small quantity of oxide of silver (prepared by pouring a solution of caustic potash into a solution of nitrate of silver, and washing well the precipitated oxide) until the solution, already turbid from iodide of silver, is of a dirty brown colour. The quantity of oxide added is of no consequence. When the solution is filtered, it will be found very slightly alkaline, in which condition it would yield foggy pictures. Previous, however, to using it, 5 minims of the following diluted acid should be added :—

Nitric acid (1.50),	.	.	.	6 minims.
Distilled water,	.	.	.	1 ounce.

The bath is now ready for use, and will prove to be in the most perfect condition. When, from repeated use, a bath becomes disordered, and produces foggy pictures, it should be tested for acidity by immersing in it a slip of litmus paper. If it do not turn red after being immersed for some time, add some of the dilute acid, given above, until it do so. Fogging in an old bath is easily cured by rendering it slightly alkaline (with diluted ammonia, for example), and exposing to sunlight for some time. By this means all organic matter is precipitated.

After filtration, one or more drops of the diluted nitric acid will be found necessary to restore the requisite acidity. Some baths, which from use or abuse have failed to yield clean pictures, have had their working qualities restored by adding a few drops of a solution of cyanide of potassium, which in the precipitation of the cyanide of silver formed carries down the offending organic matter. Each photographer seems to have his own favourite method of restoring the bath when disorganised; but as the restoration occasionally involves a loss of time, it is desirable that two baths be kept in stock, one relieving the other.

Cheap Collodion Filter.—Procure two new stoppered bottles, wide-mouthed, so that one neck will fit, after grinding with sand and water, into the other, inverted; then knock out the bottom of the inverted bottle, and grind the edges; then fit a bung, air-tight, to act as stopper; cut a funnel-shaped cork to fit in the neck of the inverted bottle, and run a quill up one side of the cork to allow the air to pass through; cement it tight with sealing-wax inside the bottle; put your cotton wool into the bottle, and commence to filter, which will answer the same as those sold at 7s. 6d.

Burnt-in Photographs.—Take saturated solution of bichromate of ammonia, 5 parts; albumen, 3 parts; honey, 3 parts; and dilute with 20 parts of water. Pour this over a glass or enamelled plate, and, after drying, expose for a few seconds under a glass transparency. Now remove to a damp room, and brush over the surface some enamel colour until the image appear. Fix with alcohol, to which a little acetic acid has been added, and when dry rinse in water, dry again, and place in a muffle to burn in.

Fixing Prints.—In various scientific journals it is stated that, if toned prints be placed in a five per cent. solution of common salt, which is then to be raised to the boiling-point, and left ten minutes, they will be perfectly fixed, and merely require washing. A very careful washing is necessary, for any trace of a chloride left in the print tends to destroy it.

Photography on Silk.—Immerse the silk in water, 1 oz.; gelatine, 5 grains; chloride of sodium, 5 grains. Hang it up

to dry ; then float for half a minute on a fifty-grain solution of nitrate of silver ; dry, print, tone, and fix as usual.

Waterproof Enamel for Card Photographs.—The following is a good substitute for the collodion transfer process, and much easier of application :—First apply with a brush to the surface of the card a solution of gum arabic, of sufficient strength to give considerable gloss when dry. As soon as dry, apply a coating of plain collodion as in coating a plate. If the collodion is not very tough, two or three coatings may be applied to advantage. Finish by passing the card through a roller, and you have a fine gloss. Take care not to have the gum solution too thick, or the surface will crack when dry, though there is but little danger if the collodion is applied soon after the gum is dry. Gelatine, instead of gum arabic, will answer, though it gives hardly as much gloss.

To Remove Nitrate of Silver Stains from the Skin.—Cyanate of potassium is dangerous, but the following may be safely employed :—Make a pretty strong mixture of solutions of bichromate of potash and sulphuric acid—say two parts saturated solution of bichromate, three of water, or one of sulphuric acid. Wash the hands well with this, then rinse them off, and have at hand some Lugol's solution, which for this purpose may be made as follows :—Iodide of potassium, $\frac{1}{4}$ oz. ; iodine, 40 or 50 grains ; water, 10 oz. After rinsing off the bichromate, wash the stains with this solution. Under its action they rapidly lighten in colour ; but the hands become stained deep orange colour by Lugol's solution. Finish them with some negative hyposulphite, which clears off all the colour that remains.

Washing Apparatus.—Attach the prints to a surface of perforated or woven material arranged round a drum, which revolves in a trough containing water, only a portion of the drum being, however, submerged. On communicating a rapid motion to the drum, the prints are alternately immersed in water, and then whirled round with sufficient force to drive off the moisture, thus securing an effectual application to the alternate washing and draining principle which, on the principle of centrifugal force, is recognised as desirable in getting rid of moisture.

Cleaning Glass Plates.—(1.) Soak them in a solution made by dissolving an ounce and a half of bichromate of potash in a pint of water, and adding about 6 drachms of sulphuric acid. Plates soaked in this solution for a few days, and then well washed, will be almost as good as new. (2.) Soak them all night in a strong solution of potash and water. Then place a plate on a flat piece of washing cloth, and with a tuft of the same rub each side and the edges with a saturated mixture of common salt and tripoli. Set the plates up to dry, and clean with a first and second towel kept for the purpose, or wash the plates, adding at first a little nitric acid. The following mixture on a cloth and tuft of its own, giving a final rub wherever the fingers have touched, is recommended:—Old collodion, 1 oz. ; spirit of wine, 2 oz. ; water, $\frac{1}{2}$ oz. ; tripoli, 1 oz. ; iodine, 15 gr. Shake and leave on plate till wanted. (3.) Make a solution of nitric acid, 1 part ; distilled water, 3 parts. Let the plates stand in this for three days, then rub them well with a cork while wet, and swill them in several clean waters.

To Clean Silver Plates.—Dr C. Calvert gives the following as a good plan:—Plunge the plate for half an hour in a solution of 1 gallon of water, 1 lb. hyposulphite of soda, 8 oz. muriate of ammonia, 4 oz. liquid ammonia, and 4 oz. cyanide of potassium ; but as the latter substance is poisonous, it can be dispensed with if necessary. The plate being taken out of the solution is washed, and rubbed with a wash-leather. The same plan may be adopted for all kinds of silver articles or thickly-plated table-ware.

To Copy Cartes without Reduction of Size.—Place the carte or other object to be copied at a distance from the lens of twice its equivalent focus, the sensitized plate being placed at an equal distance. Thus, if the lens be of six inches equivalent focus, the distance between the picture being copied and the sensitive plate on which its image is received will be 24 inches, the lens occupying a place midway between, thus having its centre 12 inches from both the object being copied and the surface on which it is copied.

Double Photographs.—These may be taken with an ordinary camera in the following way:—Against a perfectly black background, take a photograph of the person, only a little to

one side of the plate. After it has had the proper exposure, put the cap on the lens, but do not shut down the slide; then pose the person again according to taste—taking care that his image on the plate shall not overlap the previous image—and expose again, and the double photograph is taken. The first picture will not suffer from a second exposure by reason of the dark background being a negation of light. To insure a good picture the background must be perfectly black, and the object well illuminated. An acid developer is preferable.

New Filtering Apparatus.—An economic filter and percolator has been devised by an ingenious combination of syphon tube and filtering medium. Any test liquid may be drawn from a bottle in a state of limpidity, and if necessary, returned again turbid to the stock for refiltration. By slight modifications the apparatus is used for filtering alcoholic ethereal or caustic alkaline solutions out of contact with the air, and it can be adapted to a water-bath so as to admit of the filtration of gelatinous liquids. The apparatus is specially contrived for use amongst photographers; but it is evident that there are many uses in chemical, pharmaceutical, and manufacturing laboratories to which this apparatus can be economically applied.

Transferring Photographs to Metals for Printing.—Mr Woodbury of Manchester has discovered that gelatine, when dissolved in hot water, if mixed with bichromate of potash or ammonia, dried and exposed to the action of light, becomes insoluble—a result due to the decomposition of the alkaline bichromate and the liberation of chromic acid. It will be seen that a coat of the bichromated gelatine on a glass or metal plate placed under a negative and exposed to light, would, when subjected to the action of hot water, be dissolved away in some parts, and in other parts unaffected, thus producing a photographic positive *in relief*. Acting on these facts, Mr Woodbury takes the image in relief so produced, and either by mechanical pressure with some soft metal, such as type metal, or by the usual process of electrotyping, produces an *intaglio* impression therefrom. A properly-prepared ink, formed with gelatine and some black or other coloured pigment, is then passed over the plate, with which the impression is filled up even to the surface. The gradations of *relief* in the

bichromatic gelatine print form gradations of *depth* in the metal intaglio, in which again the ink, being transparent, forms gradations of blackness proportioned to its varying thicknesses. A modification of this plan is, in fact, the "Woodbury Process."

The Magnesium Light.—In reference to this wonderful mode of illumination, Professor Schrotter, of the Vienna Academy of Sciences, has obtained some important results, of which the following may be taken as an epitome :—The magnesium light promptly and powerfully produces fluorescent as well as photographic effects. This light contains an extraordinary quantity of ultra-violet rays, the spectrum of which is at least six times as long as that of the luminous portion. Crystallized platino-cyanide of barium, finely powdered or made into a paste with gum, so that it can be fixed on paper, gives a powerful fluorescence when exposed to this light. All substances which become luminous by isolation acquire this property in the highest degree by a few seconds' exposure to burning magnesium, whilst with the sun it takes five to ten minutes to produce the same effect. The light re-emitted by these bodies has no photographic power, the absorbed chemical rays being degraded to purely luminous ones. If a piece of burning magnesium wire is brought near to the sides of a white glass cylinder, filled with equal parts of hydrogen and chlorine gases, drops of hydrochloric acid will be seen to condense on the portion of the cylinder nearest the wire. If now a second piece of wire is burnt on the opposite side of the glass, an explosion takes place almost instantaneously. By means of the magnesium light instantaneous photographs may be taken.

Artificial Light for Photographers.—Professor Falkland recommends peroxide of nitrogen, which may be thus produced :—A light bottle is taken, of about a pint capacity ; it is fitted with a cork, through which passes a glass tube, bent to a right angle a little above the top, and the end drawn out so as to form a jet, the tube being bent like the letter U, so that the jet looks upward. The only other essential vessel is a test-tube, or narrow beaker, into which the U tube can easily dip. Fragments of copper, either plate or wire, are placed in the bottle, with a mixture of one part strong nitric acid and two of water. The cork, with its tube, is replaced ; the little beaker

is placed in a vessel of warm water, and the bottle is placed so that the bent portion of the tube dips into the beaker. As soon as the gas comes freely through the jet, some bisulphide of carbon is poured into the beaker. The hot water with which the latter is surrounded quickly vaporises the bisulphide, which, when set fire to, burns at the mouth of the beaker with its usual blue lambent flame; but from the gas jet upwards for an inch or more, according to pressure, arises a brilliant cone of flame, giving intense light, and possessing great actinic power. The current of gas should be tolerably rapid, and the bisulphide well heated to ensure the best effect, and it should not be forgotten that the burning bisulphide gives off abundance of deleterious fumes of sulphurous acid.

Easily-prepared Photographic Varnishes.—Procure some good gum benzoin; place it in an earthenware or metal capsule, and apply moderate heat until it is perfectly fluid. Then pour it upon the bottom of a cold plate, and, when it has been quite cold, it may be broken off in pieces. To form the varnish, the following recipes are good. The second is more expensive than the first, but a little better:—

(1.) Dissolve in 8 oz. of methylated alcohol 1 oz. of the fused benzoin and 20 grains of sandarac; then add 20 drops of mastic varnish, made by melting gum mastic, and adding turpentine to it whilst in a fluid state. The impurities will soon settle, and the varnish is ready for use.

(2.) Fused benzoin,	$\frac{1}{2}$ ounce.
Sandarac,	10 grains.
Jalap resin,	$\frac{1}{2}$ ounce.
Methylated alcohol,	8 fluid ounces.
Mastic varnish,	20 drops.

Should either of these varnishes be too thick, or become so by use, they may be diluted with a little more spirit. Should the spirit be too strong, which may be known by its partially dissolving the collodion film, a very few drops of water may be added. When using either of the above preparations, the negative may be varnished twice without any danger. This enables us to touch out any spots, &c., on the negative, and then revarnish.

(3.) M. Bussi first brushes the prints over with a solution of

gum arabic, and when this is dry, applies a coating of collodion. The following are the proportions recommended :—1. Clear transparent gum arabic, 25 grammes ; distilled water, 100 cubic cents ; dissolve and strain. 2. Gun cotton, 3 grammes ; alcohol, 60 grammes ; ether, 50 grammes. By this double varnish the preservation of the proofs is insured.

Fixing Solution.—A good fixing solution should consist of 4 oz. of hyposulphite of soda in a pint of water, and should always be used fresh. The number of prints of a given size which may be safely fixed in a definite quantity of hypo-solution cannot be absolutely stated. Theoretically, about three parts of hyposulphite of soda will be required to dissolve one of chloride of silver. One whole sheet of sensitive paper has been calculated to contain about from 25 to 30 grains of chloride of silver. On this theory about half a dozen sheets of paper might be fixed by 1 oz. of hyposulphite of soda. In practice, however, so many other circumstances interfere, that perhaps not more than one-fourth of that number ought to be fixed in the quantity. In very cold weather, the solution is comparatively inactive ; it is well, therefore, to raise the temperature to about 60° Fahr. Thin *Saxe* paper will generally be fixed in new hypo, of the strength named, in about ten minutes ; thick *Saxe* will require fifteen minutes ; thin *Rive* paper about fifteen minutes, and thick *Rive* about twenty minutes. A slightly albumenized paper will be fixed more rapidly than a highly albumenized sample ; the principle being, that the more horny and repellent the surface, the longer the time of immersion. Complete immersion and constantly moving about are imperative.

Focusing Screen.—Take a piece of patent plate-glass, the size required, lay it down on a perfectly flat bench or board, with a small tin tack or two on each side of the glass to keep it in place ; then take a pinch of the Wellington knife-powder, which will be enough to grind a score of screens. Apply the powder to your glass with a few drops of water, and mix till about as thick as cream ; then take a piece of thick plate-glass about 1 inch square, and grind the surface of your glass with a regular motion of the hand slightly bearing on till you get a good face, which will take from half an hour to one and a half hours according to the size of screen. Apply fresh powder and

water at times, and to see how you are getting on with it, wash in clean water, and dry very steadily before a fire or in the sun ; and if the screen has not a nice regular clean face apply the same means over and over again if required, till you get it to your mind, but do not put on any fresh powder in the finishing for the last quarter of an hour, as it will give a finer surface.

A Good Developer.—Mr Carey Lea recommends the following :—Dissolve 10 grains of Nelson's gelatine in an ounce of Beaufoy's acetic acid—that at 10d. per lb. Make your new developer of the strength you are accustomed to use, of course without any acid ; and to each ounce of it add one drachm of the gelatinised acetic acid. You will be pleased with the result, and with its cleanliness and ease of preparation. This developer will be found to bring out the images with unusual vigour and brilliancy, and may be retained on the plate for a long time without “fogging.” Where from unavoidable difficulties under-exposure has arisen, this quality alone will render it invaluable.

Sensitizing Paper.—Albumen, 1 oz. ; water, 1 oz. ; chloride of ammonia, 10 grains. The paper is first floated on this and then ironed. It is then again floated on a bath of nitrate of silver, of the strength of 40 grains to 60 grains to an ounce of water.

Purple Staining.—Take a moderate-sized cigar-box, with lid to fit close. Half-way up the box bore half a dozen holes large enough to admit thread each side. Strain tightly, from side to side, a half dozen pieces of thread ; fasten with wooden plugs. After the prints are “toned,” “washed,” and “fixed” in the usual way, dry them well, then lay them faces down on the thread. Underneath place a small saucer containing some carbonate of ammonia. Shut the lid of the box tightly. Expose the prints to the fumes from five to ten minutes, or longer if required. Examine occasionally until the desired effect is produced.

Glass Globes for Magnifying Glasses.—A small piece of very fine glass sticking to the wet point of a steel needle is to be applied to the extreme bluish part of the flame of a lamp ; (a spirit lamp is best ;) being there melted and run

into a little round drop, it is to be removed, upon which it instantly ceases to be fluid ; folding then a thin plate of brass, and making very small, smooth perforations, so as not to leave any roughness on the surface, fit the spherule between the plates against the apertures. The same may be inserted in brass or ivory tubes for the photo-micro objects.

Freezing Mixtures.—The following table of frigerific mixtures, without ice, may be useful to many photographers in hot climates or our own country, to keep cool their baths or other chemicals by immersing their bottles, &c. :—

Mixtures.	Thermometer Sinks.	Deg. of Cold produced.
Common salt..... 5 parts. Nitrate potass..... 5 „ Aqua 16 „	From + 50° to + 10°	40
Muriate ammonia..... 5 parts. Nitrate potass..... 5 „ Sulph. soda..... 8 „ Aqua..... 16 „	From + 50° to + 4°	46
Nitrate ammonia..... 1 part. Aqua..... 1 „	From + 50° to + 4°	46
Nitrate ammonia..... 1 part. Carb. soda..... 1 „ Aqua..... 1 „	From + 50° to — 7°	57
Sulph. soda..... 3 parts. Dilute nit. acid..... 2 „	From + 50° to — 3°	53
Sulph. soda..... 6 parts. Muriate ammonia..... 4 „ Nitrate potass..... 2 „ Dilute nit. acid..... 4 „	From + 50° to — 10°	60
Sulph. soda..... 6 parts. Nitrate ammonia..... 5 „ Dilute nit. acid..... 4 „	From + 50° to — 14°	64
Phosphate soda..... 9 parts. Dilute nit. acid..... 4 „	From + 50° to — 12°	62
Phosphate soda..... 9 parts. Nitrate ammonia 6 „ Dilute nit. acid..... 4 „	From + 50° to — 21°	71
Sulph. soda..... 8 parts. Muriatic acid..... 5 „	From + 50° to 0°	50
Sulph. soda..... 5 parts. Dilute sulph. acid..... 4 „	From + 50° to + 3°	47

If these are mixed at a warmer temperature than that expressed in the table, the effects will be proportionately greater ; thus,

if the most powerful of these mixtures be made when the air is $+ 85^{\circ}$, it will sink the thermometer to $+ 2^{\circ}$.

Plate-Holder.—In most plate-holders the glass is fixed with screws, which take some time to adjust. In this little

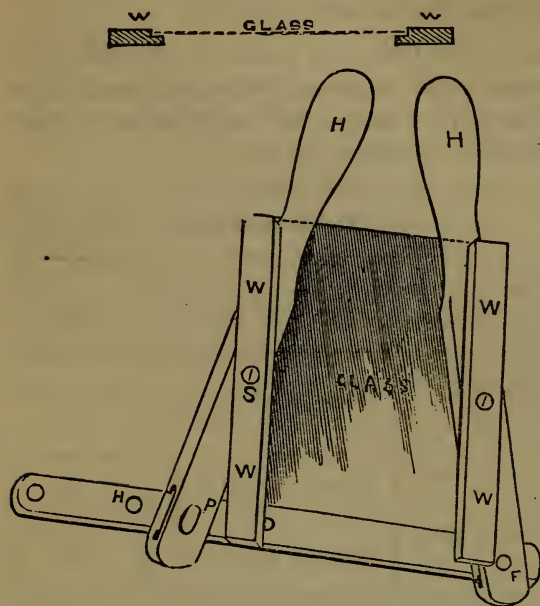

instrument the adjustment is instantaneous, besides the advantage of more accurately fitting the edges of the glass, and thereby lessening the chance of breaking. It can also be used as a holder for exhibiting a portrait before dry. It is easily made, and amateur photographers will find it of service.

H, H, handles ;
S, S, screws allowing the wood W, W, to form themselves parallel by the pressure of the glass edges ; H, H, holes in the lathe ; P, pin ; F, fixed pin.

Magic Lantern Photography.—Photographs may be produced with a camera made in the following way :—A is an ordinary $\frac{1}{4}$ -plate lens, B the focusing screen, C a slide for holding negative. It

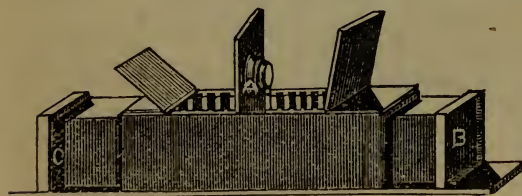

will be observed from this sketch that transparencies may be produced from negatives of the same size, or larger or smaller.

While being used it may be tilted so as to allow the light of the sky to pass through the negative, or it may be used horizontally with a white screen to reflect light through the negative. The chemicals are the same as are used for negatives. Care

must be taken that the silver bath and developer are sufficiently supplied with acid to prevent the slightest appearance of fogging. Or you may print from the negative by contact on glass or mica by the collodio-chloride process, which gives very fine results.

Black for Retouching Photos.—Indian ink consists of the charcoal of fish bones, or a vegetable substance, mixed with isinglass size, and probably honey or sugar to prevent its cracking. A substance much of the same nature, and applicable to tinting those enlargements denoted black and white, may be made thus :—Take 3 oz. of isinglass, form it into a size by gentle heat in double its weight of water ; then take half an ounce of Spanish liquorice, dissolve it also in double its weight of water, and grind it up with half an ounce of fine ivory black ; add this to the size while hot, and stir well together till thoroughly incorporated ; finally evaporate away the water, and cast the remaining composition into leaden or other greased moulds. The colour of this composition will be equal to the finest Indian ink ; the liquorice will render it easily dissolvable on rubbing up, and prevent its cracking or peeling from the ground on which it is laid.

Retouching.—Many photographs need to be retouched. Retouching is undoubtedly more practised on the Continent than it is in this country, and is occasionally used in the whole of the three possible forms :—Retouching on the model, such as strengthening eyebrows, deepening eyelashes with coloured “cosmetic,” or the use of violet powder to red hair ; retouching the negative with pigment or blacklead pencil ; and retouching the print with a suitable water-colour. The darkening of eyebrows or eyelashes merely for securing an improved effect in the portrait is of course unjustifiable, inasmuch as it would alter nature and spoil the likeness, unless the sitters are in the habit of defacing nature by appliances of powder, paint, and dyes. The use of violet powder to modify the effect of red hair requires great skill not to produce an unnatural effect, but it is at times useful and effective. Retouching the negative requires much skill to produce a good effect, but if done with judgment and skill is very valuable. It is effected with a lead pencil, to soften harsh lines in the face, and strengthen the detail in a few shadows. It in nowise interferes with the truth of nature,

but modifies and ameliorates the inherent defects of photography, or of the photographic negative. In retouching a print, the great aim should be to do the least possible to effect the end in view, and especially to let the addition be in strict harmony with the peculiar characteristics of the photograph. For instance, any attempt to stipple upon a face in a formal way will generally issue in the necessity of covering the whole face with such stippling or hatching; whilst a few skilful touches imitating the quality of texture or kind of detail in the print might have produced a really better and more pleasing result with one-tenth of the labour.

Composition Pictures.—In the Exhibition of 1871, many photographs that were much admired were, in fact, simply “compositions” from several negatives. Composition pictures—says Mr E. Dunmore, the well-known amateur photographer—are certainly the most daring attempts to burst the bounds of what is considered the limits of a process, and are attempts worthy of imitation by all. Light and shadow are our sheet anchors. A clever arrangement of the chiaroscuro, and a few touches, will make a picture, when myriads of touches and bad lighting will make a photograph the derision of every one who knows anything about art, perfect, perhaps, in its chemical aspect, but horrible in its pictorial one. When we see a beautiful result, we are apt to overlook the time, care, skill, energy, and battling with almost insuperable difficulties necessary to its production. The result is all we know, if it be good or bad. If good, no one can imitate it without undergoing the same ordeal to procure the negatives.

Reproducing Negatives.—When it is desired to duplicate a negative, the following plan is to be adopted :—Spread on a glass the same size as the negative a mixture of bichromate solution, gum, and honey, to expose under the negative, and, after exposure, dust over with a pigment, which adheres to the unexposed parts, and forms a negative. This is to be washed with a mixture of alcohol and glacial acetic acid, which removes the bichromate without dissolving off the gum. Negatives obtained in this way are reversed, and give reversed positives. They are useful for photolithographic transfers. Instead of dusting the exposed plate with pigment, enamel powder may be used, and the plate may then be burned in, and a negative

of absolute permanence be obtained. (It seems doubtful if such a burned-in negative could have the fulness of detail of a collodion negative, from the tendency of colours to run a little when fused.)

To Photograph Drawings, Manuscripts, &c.—The usual method is to copy them by reflected light, but Professor Fowler adopts the following :—The paper suitable is very thin, homogeneous in texture, and machine-ruled or lined in the pulp or mass of the paper itself. Upon these lines the manuscript is carefully and boldly written, and so that not a single stroke is wanting. As soon as the page is complete, and the ink quite dry, make the paper transparent with a mixture of olive oil and turpentine, applied by means of a fine sponge to the back. The sheets are then hung up to dry. To obtain a negative of the manuscript, use dry tannin plates, and print by contact. In the printing-frame place first a clean flat glass; upon this lay the manuscript, the back in contact with the glass; and, last of all, press the tannin plate into close apposition with the writing of the manuscript. The door is then closed. This operation is performed, of course, in the dark room. The front of the printing-frame is covered with a thin board, slate, or tin plate; and having brought it in this condition into the light, the board is removed from the front, and the manuscript is exposed for a few seconds. Replace the board, and carry the printing-frame back into the dark room. Here the negative is developed with pyrogallic acid and silver, and then fixed. The parts beneath the ink-marks are naturally transparent, whilst all the rest is uniformly opaque to the rays of light. This opacity is much more dense and uniform than that which is obtained by copying by means of reflected light. After washing, the plate is dried and varnished. A dozen similar negatives are soon taken in this way; and it is then an easy task to print several hundred facsimile copies of the manuscript or drawing.

Photographic Prints on Linen and Cotton.—Handkerchiefs, &c., are often ornamented with photographs, and, as a matter of curiosity, it may be as well to describe the process. The linen or cotton cloth is first freed from its “dressing,” and then coated with the following preparation :—Distilled water, 125 cubic centimetres; chloride of ammonium, 1 gramme; the

white of one egg. The surface of the fabric is allowed to remain for five minutes in contact with the albumen mixture, then dried, and afterwards rendered sensitive by floating it on a ten per cent. solution of nitrate of silver. The latter operation takes five or six minutes, and requires to be conducted with great care, as spots will inevitably occur in places where the silver solution touches an unalbumenized portion of the fabric. The printing should take place on the same day as the sensitizing, the remaining operations being proceeded with in the ordinary manner. Photographs produced by this method are very permanent, and may be washed with soap without sustaining injury.

Design for a Photographic Studio.—Here we have the ground-plan of a photographic studio which has been found very effective. It is of what has been called the tunnel class, but differs from the kind recommended in the photographic journals in the larger amount of light it admits. Indeed it is probable

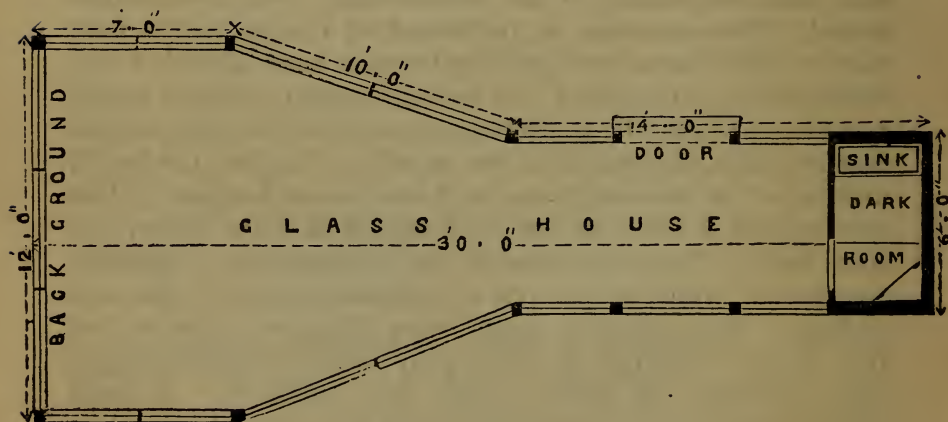

that, in an open situation, too much light would find its way to the sitter, and some would therefore have to be shut off; but of two evils, too much and too little light, the former is certainly the smaller, and is moreover advantageous, inasmuch as when decreased the shut out portion serves as a kind of reserve force for dull weather. It is based upon a design of admitted excellence, but the proportions differ considerably, so as to fit it for the use of amateur photographers.

Dark Box for Field-work.—When set up for work, the dimensions of the box herewith described are :—Length, 18 in. ; width, 14 in. ; height, 13 in. ; outside measure when packed, $5\frac{1}{2}$ in. thick, or about the size of a soldier's knapsack. It is

made of very thin deal covered with oil-cloth, and has round each corner pieces of sheet-copper riveted. At each corner, also, inside, there is a light ash upright, hinged by passing a screw through the longest side of the box, and riveting it in the upright, which can then fold down between the edges of the sides, top and bottom. There are three thicknesses of black calico tacked, and in the top of the box there is a lid of sufficient size through which the bottles of chemicals, &c., are handed. To set up the box for working it is fastened on its tripod stand, the screw-bolt of which, by

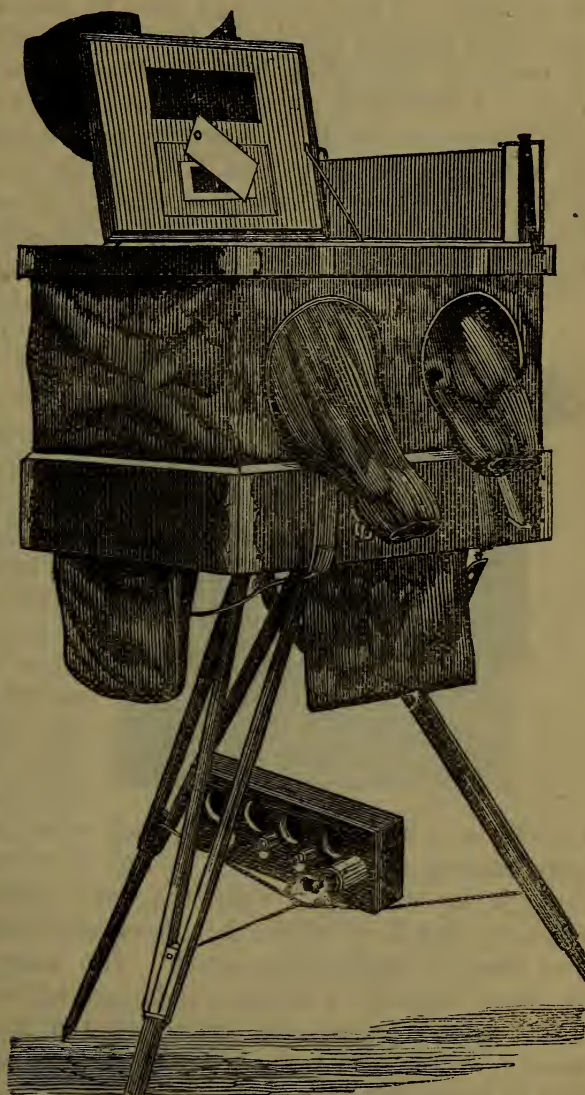

a simple contrivance, slips into a groove in the box, and the straps which go quite round being undone, the lid is raised ; and the top being supported with one hand, the uprights are

lifted with the other, and entering into small blocks in the top, stretch the calico sides, and the whole thing is quite firm. In the side of the calico, next the operator, there are sleeves through which he passes his hands to enable him to see what he is about. There is a large plate of yellow glass in the lid, and when his eyes are shaded he can see perfectly. The shade is made of stiff oil-cloth covered with black velvet; it has pieces of sheet-iron riveted on to it at right angles, which slip into grooves in the lid. Anything to cover the head would do as well, but the other plan is the most convenient to admit light into the box. There is a yellow-glass window in the side farthest from the operator, made by glueing a light wooden frame to the calico, the glass resting in a rabbet, and having a

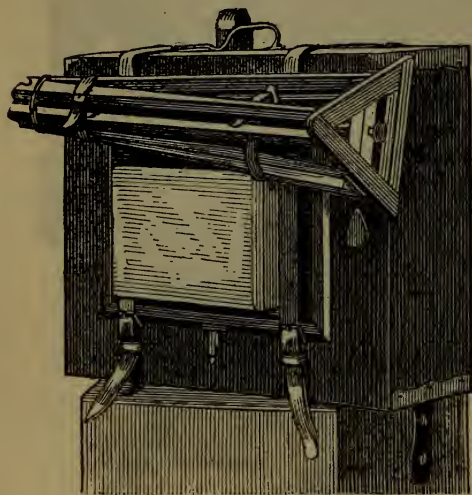

metal frame screwed over it. There is another small light in the lid which can be shut out by a revolving metal cover from the inside; but it is only needed in a very dull light. In the floor of the box there is a yellow glass, so that in developing it can be seen when all the half tones are out by looking through the negative, a point of great importance. The bath is sunk through an

opening in a bag, also the dark slide when done with. These bags have strong wire frames at top to prevent their slipping through the openings. Keep the bath always covered. The holes in the floor of the box have sheet-iron frames riveted over them to support the wood. The water-can is placed on the top, and the water is conducted on to the plate by an elastic tube, a patent slip cutting off the stream. The waste water from the dish is carried off by a tube passing through the bag in which the bath is placed. There is a wooden rack for bottles which contains everything for a long day's work, including chemicals for extra developing and fixing solutions, and bottle of bath solution for filling up; the gutta percha or glass

bath is made water-tight by a strap of -wide hoop-iron passing under it, and the ends being turned up the clamp catches them and presses the piece of wood and the indiarubber down on the top of the bath. When the box is packed for travelling, the bath lies inside the tin water-tray or dish; and it rests on the dark slide. The bottle-rack and the water-can fill up the remaining space; the cleaning cloths keeping all snug. The plate-box hooks on the lid, protecting the yellow glass; it will hold six plates, either half plates ($6\frac{1}{2} \times 4\frac{3}{4}$), or 4×5 plates; they rest at two corners in grooves, and at the other corners on movable slips of wood, so that both sizes can be carried together, and cannot possibly get rubbed; of course the smaller plates must be the upper ones. The folding tripod-stand is fastened to the top above the plate-box. Carry the pack like a knapsack, and you can go six or eight miles without fatigue; the weight is only about 20 lbs.

A

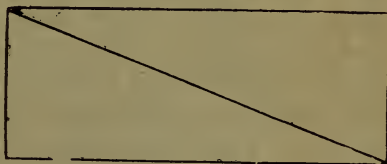

Dark Tent.—Mr Wilson, of Aberdeen, recommends the following plan:—The tent is composed of a light tripod of the

usual height for the framework, and a covering of three folds of twilled calico, two black and one yellow. The cloth is first cut into lengths, about a foot more than the length of the tripod

frame, then folded from opposite corners, so

that each piece may be cut along the diagonal of the parallelo-

gram into two triangles A, which are after-

wards sewn together so as to form, when

laid flat on the floor, about three-quarters

of a circle B. The edges are cut evenly

round, and bound with tape, and when a square hole has been

cut out of the two outer folds of black calico and two folds of

yellow cotton to act as a window have been substituted, the tent

B

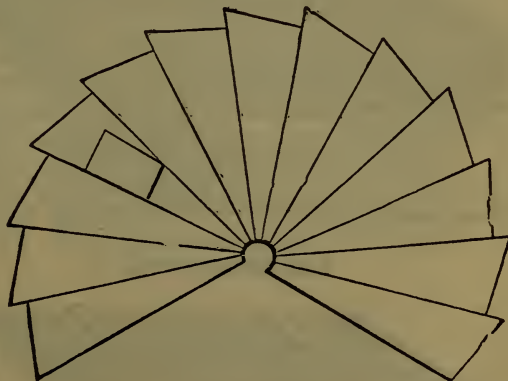

cut out of the two outer folds of black calico and two folds of yellow cotton to act as a window have been substituted, the tent

is complete. It can be pitched in half a minute by stretching out the tripod, until the legs are about three feet apart; and when a few stones, pieces of wood, or anything handy, are placed round the bottom inside, it is ready for the bath and bottles.

Portable Photographic Tent.—The roof is made of four pieces of timber 4 feet long and about $\frac{3}{4}$ in. square, which are hinged to a circular piece of wood about 4 in. in diameter, in such a way as to admit of their shutting up like an umbrella. To each of these “rafters” is nailed double calico, black lined with yellow. The eave overhangs about 3 in., on the inside of which are stitched strong hooks about 6 in. asunder, on which are hung the sides or walls of the tent. The legs are the same size as the rafters, 4 feet long and $\frac{3}{4}$ in. square. They are hinged to the inside of the rafters, and can fold in when shut up. Each leg is connected by a strong galvanized wire which hooks into eyes (those used for stair rods will answer) close under the eave. Four strong cords from the top pass down each angle, through a couple of eyes, on to the ground, where they are secured by iron pins, thus making the whole perfectly steady. The sides are also black lined with yellow, and for convenience are divided into two parts 4 feet 3 in. wide, and long enough to allow an overlap of 1 foot at each joining. The

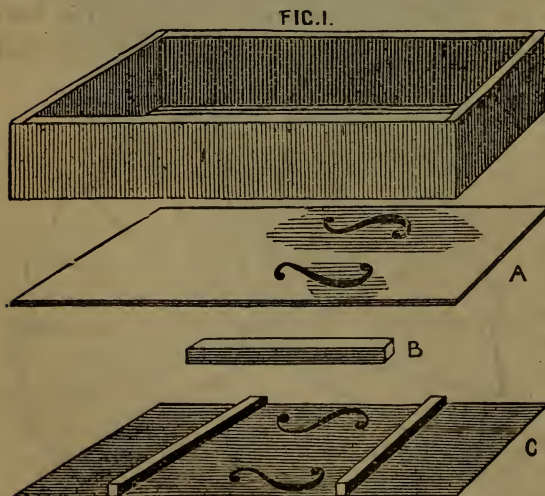

door is made by unhooking three or four eyes, folding back the curtain, and hooking it on some of the inside hooks. Thus a perfect photographic tent is made, which might be serviceable for several other purposes.

Æolian Harp.—

In the first place, a box must be made of twelve-cut board; the length to be the width of the window; the box 6 in. deep, and from 8 in. to 12 in. in width, as shown

fig. 1. A board must next be cut to fit the top of the box, with two openings A for sound, and be glued down. Take two pieces, as B, and glue across, as shown in C; these are to act as bridges for the strings.

The strings are next to be placed across from one end to the other, passing over the top of the sounding-board, and resting on the two bridges; the strings must be fastened by placing nails at one end to attach them, and screws at the other, the screws to be used

so as to slacken and tighten as required. Over these strings must be placed another piece, as A, without the incisions; this is to rest on four small pegs, 3 in. in length, placed at each corner.

The window is then to be shut down on the top of this board, as in fig. 2, when the wind will pass through the strings, causing a most delightful harmony, especially if a door or window in an opposite part of the apartment be left open to cause an extra draught or current of air.

The strings must be of small catgut, and must not be made too tight, or they may be stretched simply between two thin boards, about 1 in. or $1\frac{1}{2}$ in. apart, and made to fit the window.

Another method.—The annexed sketches will explain:—

1. Top, 2 ft. 6 in. long, 5 in. wide, $\frac{1}{2}$ in. thick. 2. Bottom,

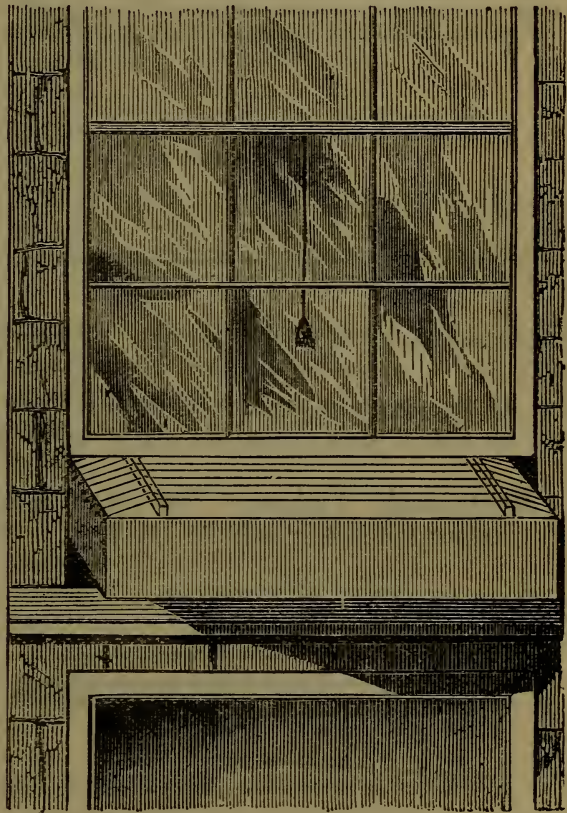

the same length, &c., as top, with two bits of wood *aa*, 2 in. by 5 in. long, $\frac{1}{4}$ in. thick at each end, *bb* two bridges for the strings to rest on. The strings must not be tightened too much, but be regulated so as to be moved by the wind; *cc* four screws to hold the box firm. The strings must be in the centre of the opening *o*. You must obtain four catgut strings, two of

FIG. 1.

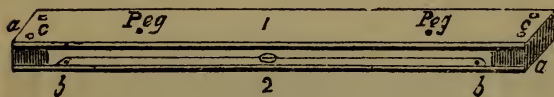
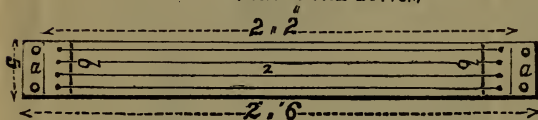
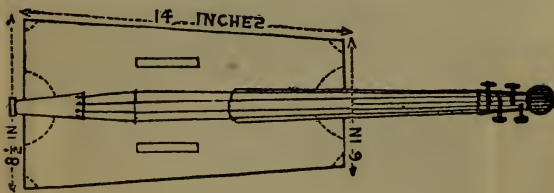

FIG. 2. THE BOTTOM



the smallest size, to put in the front side, that is the sidewhich the wind first acts on, and the other two at the back. The four strings are fastened to the four holes at each end, as seen in fig. 2, and the top must be plain, with two holes at each end to screw to the bottom. When you wish to hear it play, fix it under the bottom sash of the window, taking care to put two pegs in the top to keep it from falling. One made on the above plan played for six or seven years.

Home-made Violins.—The more simple the form of the instrument the better will be the tone. The backs and sides



of the Cremona violins were made of maple, and the bellies of pine wood well seasoned and dry. A plain deal box, with a violin neck glued to one of its ends, and fitted up with strings, bridge, &c., will be found far superior in point of tone to the ordinary run of violins. The back and belly are of soft pine wood (the grain very strong and equidistant) 14 in. in length; width at bottom end $8\frac{1}{2}$ in.; width at top end 6 in. Of course the back and belly are made of two parts each, glued straight up the middle, and the thickness of each is 1-5th of an inch in the middle (where the pieces

of the Cremona violins were made of maple, and the bellies of pine wood well seasoned and dry. A plain deal box, with a violin neck glued to one of its ends, and fitted up with strings, bridge, &c., will be found far superior in point of tone to the ordinary run of violins. The back and belly are of soft pine wood (the grain very strong and equidistant) 14 in. in length; width at bottom end $8\frac{1}{2}$ in.; width at top end 6 in. Of course the back and belly are made of two parts each, glued straight up the middle, and the thickness of each is 1-5th of an inch in the middle (where the pieces

are joined together), diminishing gradually right and left to 1-12th of an inch at the edges; the depth of sides is 2 in., and the sound-holes are straight instead of being curved like an *f*. The neck and pegs are the same as other violins. If the instrument is to be varnished, the best varnish is shellac, dissolved in spirits of wine. Any druggist will give it the proper stain. It does not signify what the colour is. The wood must not be stained before varnishing, as it will close up the pores, and so prevent a free and energetic vibration. The prefixed is a rough sketch of the home-made violin; the dotted lines show the blocks in the inside for strengthening the instrument. Its internal capacity is greater than ordinary violins. The young musician, who wants an eloquent violin of the ordinary shape, will find full directions for striking out and making entirely in Otto's "Treatise on the Violin."

The tone of a violin depends chiefly upon the form, size, thickness, and quality of the wood. The size of the body of a violin is about 14 in. long, $4\frac{3}{4}$ in. wide across the "waist," or narrowest, and $8\frac{1}{4}$ in. over the widest part of the back and belly. If the length, 14 in., be divided into 72 parts, it will form a convenient scale for measurement, and will accordingly be so made use of in this short account.

The form, taking the violin as seen flatways, is best obtained from some violin of good pattern. But as power and brilliancy of tone are, in a great degree, due to the reflection of the vibrations (passing from the bow down the bridge and sound-post into the body of the violin), from the ribs as the containing boundary, back to the centre of the body (a fact not noticed by Otto or others), the form of the sides or ribs is a matter of some consequence. That a square violin reflects these vibrations only from side to side and end to end, and does not concentrate, or focus them anywhere, must be obvious. And that such a form has power, is due only to its greater capacity, it being well known that large violins are most powerful in tone, and, therefore, in most request with skilled concert-players. As to the form taken, as the violin is seen sideways, it should be even more particularly adapted for the reflection of vibrations noticed, and is evidently so in all good instruments. The section of the back and belly of these, taken at the narrowest part or waist, will be found (outwards) concave near the side and convex in the centre, and this plan prevails more or less

all round the body. Old violins are, however, constantly seen with a wholly different model, convex in almost every part, high, and bulging towards the ribs; but they have always a dull, hollow, tubby sound, which appears as if it could not get out, owing, doubtless, to the form inclining the reflection of vibration towards the ribs, instead of to the centre of the body. It would be difficult to give an exact section of back or belly of a violin, as it must depend upon the eye (bearing in mind the principle of reflection of sound) to model out these curved forms into flowing gradations from concave to convex.

One mistake into which a beginner is likely to fall may here be pointed out. As the edges of the back and belly are a trifle thicker where they are glued to the sides, and as the outside is

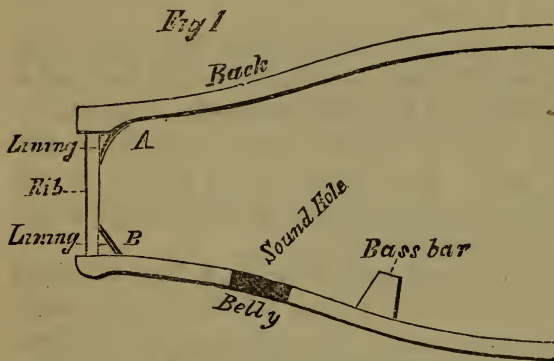

formed before hollowing out the inner, allowance must be made for this extra thickness, or the inner side of the back or belly will be concave where it should be convex, as at A, the proper form being as at B.

Violin-making is an art requiring ex-

perience and skill, and those wishing to succeed should, as in other arts, study what has been done by the most skilful; and in this department Straduaris and Joseph Guanerius stand foremost, and have left the finest specimens of their particular skill, which should form the model for a good-toned violin.

Dimensions of various parts of Violin.

Sides or ribs, $\frac{1}{3}$ of a part thick.

Sides or ribs, $6\frac{1}{4}$ parts wide, diminishing gradually to 6 parts at the neck.

Side linings, $\frac{1}{2}$ part thick, $1\frac{1}{2}$ parts broad.

Upper block, 10 parts broad, 4 thick.

Lower „ 8 „ „ 4 „

Corner „ 8 „ „ 4 „

Belly under the bridge two-thirds of a part thick, diminishing

gradually to one-third at the edges. Back under the bridge one part thick, diminishing to half a part at the edges. The external edges of back and belly should be left rather thicker for strength. Bass bar, an inside piece glued to the belly and standing under and supporting the left foot of the bridge, thirty-six parts long, one and one-fifth parts broad, two parts thick in the centre, diminishing to two-thirds of a part at each end. In fig. 1, a half section, these parts are shown.

Wood.—In good violins the back, ribs, and neck, with key-box, are made of a species of foreign sycamore or maple, called harewood, the belly and sound-post of Swiss deal: for the former, English sycamore is too soft; maple would probably be the best English wood; and the best substitute for Swiss would be Finland deal, selected free from turpentine, light in weight, and of fine and regular bate or grain, from a centre plank, which should show the grain on the edge as well as the surface. All wood used should be thoroughly seasoned. It is said that wood, if often baked for the purpose of more completely freeing it from turpentine, &c., a certain crispness in the tone may be thus acquired. It should have been stated that the small blocks are made of saw-wood, but deal may be used.

Tools.—In making this violin, it is necessary to have 20 or more small wooden cramps made of close-grained wood, like the sketch; of beech or birch, 3 inches or more in length, 1 in.

wide at each end, and half an inch thick, with a notch *dd* $1\frac{3}{4}$ in. long, to receive the edge of the violin, which we

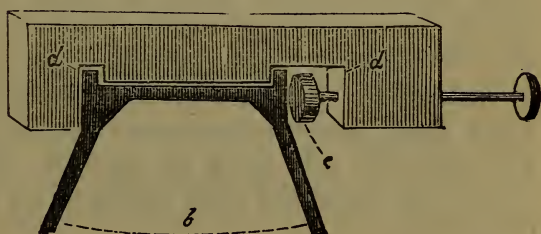

get tight by two thin wedges, $1\frac{1}{4}$ in. long, $\frac{1}{2}$ in. broad, and $\frac{1}{8}$ in. thick, entering one at each side, as at *c*, the wedges being placed on the back and belly, but not on the ribs. If in the event of being often wanted, wire-tapped screws wormed into the ends of the cramps as shown might be used made of about No. 10, or 1-10th of an inch wire, and got tight against wooden hooks, as at *c*, *b* being the violin. In commencing, let the amateur first cramp the back to the sides, exactly where

it requires to be, with five or six cramps on each side ; then release one side, which will spring off sufficiently to be glued. When glued, nip close together with ten or twelve cramps. This done, release the other side, glue and cramp it in the same manner. Then set it to dry and harden for a day or two before repeating the same process with nothing on the belly. When thoroughly dry, scrape off any superfluous glue from the edges. If any crevices appear, trace a little hot thinish glue, with the small end of a skewer, round the edges, so as to smooth or fill up every crevice.

Musical Vibration.—The tones of violins being so various, it is almost difficult to judge the difference, or best, from the various tastes of players. Some like a fine or firm tone, some a loud tone, some a hard, sharp, or leading tone, some a crisp or wiry tone. Each may be deemed best in the estimation of such a variety of advocates. A violin with back, belly, and sides, all of pine, is not likely, as a general rule, to produce a fine clear tone, save from the spontaneous harmonizing vibrations, perchance, of back and belly. It is impossible for any manufacturer of violins, however defined his rule for construction may be, to produce two or more consecutive violins that will possess an equal number of free vibrations of back and belly (minus the sounding-post), that is to say, the backs and bellies of each violin would not be in union with each other in their vibrations ; nor equal in power, tone, or quality. No doubt, the finest-toned violins would be those whose natural free vibrations of backs and bellies are in unison, or in octaves to each other. But such occurring by chance is a mere lottery. Even those whose spontaneous free vibrations closely harmonise together will have an especial superiority over others whose free vibrations class amongst the wide-spread intervals of discord.

Preserving Skins.—*Small skins* may be preserved in the following manner. They are first cleaned and scraped ; they are then rubbed over with arsenical soap, prepared thus :—To four pounds of white curd soap add one pound of arsenic and one ounce of camphor ; cut the soap into thin slices, and dissolve it in one pint of water. When melted, add the arsenic and camphor, stirring them well together, and boil again, until the substance of a thick paste is attained, and pour it into jars

while hot. When cold, tie it up carefully with bladder, and it will retain its qualities for years.

Rabbit skins, and indeed any moderately small skins, may be made white and the coat preserved, by first taking a blunt knife and scraping the skin on a piece of circular wood, so as to get off as much of the flesh and fat as possible ; then make a solution of alum, salt, and water, four to one of alum, as much as the water will contain. Dissolve the alum in hot water, when cold immerse the skin in it, and in about forty-eight hours the skins will be cured. Wash in a weak solution of soda and water, to carry off any fat that may remain. If for sheep, or other skins that are thicker, a longer time will be required. The skins should be pulled about before thoroughly dry to stretch them. This plan is a very fair one, but is, of course, not perfect.

Bird-Stuffing.—First dissect your specimen. In *dissecting*, three things only are necessary to ensure success, viz., a pen-knife, a hand not coarse and clumsy, and practice. In *stuffing*, you require cotton, a needle and thread, a little stick, glass eyes, a solution of corrosive sublimate, and any kind of temporary box to hold the specimens. Wire is worse than useless, as it gives a stiff appearance to the object stuffed. A very small proportion of the skull-bone, say from the fore-part of the eye to the bill, is to be left in, part of the wing-bones, the jaw-bones, and half of the thigh-bones remain. Everything else—flesh, fat, eyes, bones, brain, and tendons—are all to be taken away. In taking off the skin from the body, it will be well to keep in mind that you must try to shove in lieu of pulling it, lest you stretch it. Throughout the whole operation, as fast as you detach the skin from the body, you must put cotton immediately betwixt the body and it ; this will prevent the plumage getting dirty. Let us now proceed to dissect a bird. Have close by you a little bottle of corrosive sublimate, also a little stick, and a handful or two of cotton. Now fill the mouth and nostrils with cotton, and place it on your knee on its back, with its head pointed to your left shoulder. Take hold of the knife with your two first fingers and thumb, the edge upward ; you must not keep the point of the knife perpendicular to the body of the bird, because, were you to hold it so, you would cut the inner skin of the belly, and thus let the

bowels out. To avoid this, let your knife be parallel to the body, and then you can divide the outer skin with great ease. Begin on the belly below the breast-bone, and cut down the middle, quite to the vent. This done, put the bird in any convenient position, and separate the skin from the body, till you get at the middle joint of the thigh. Cut it through, and do nothing more there at present, except introduce cotton all the way on that side, from the vent to the breast-bone. Do exactly the same on the opposite side. Now place the bird perpendicular, its breast resting on your knee, with its back towards you. Separate the skin from the body on each side of the vent, and never mind at present the part at the vent to the root of the tail. Bend the tail gently down to the back, and while your finger and thumb are keeping down the detached parts of the skin on each side of the vent, cut quite across and deep, until you see the backbone near the oil-gland at the root of the tail. Sever the backbone at the joint, and then you have all the root of the tail, together with the oil-gland, dissected from the body. Apply plenty of cotton. After this, by shoving and cutting, get the skin pushed up until you come to where the wing-joints join the body. Apply cotton, and then cut this joint through, and do the same at the other wing; add cotton, and gently push the skin over the head, cut out the roots of the ears, and continue skinning till you reach the middle of the eye; cut the membrane quite through, otherwise you would tear the orbit of the eye. After this nothing difficult intervenes to prevent your arriving at the root of the bill; when this is effected, cut away the body, leaving just a little bit of the skull; clean well the jaw-bones, and touch the skull and corresponding parts with the solution. Now all that remains to be removed is the flesh on the middle joints of the wings, one bone of the thighs, and the fleshy root of the tail. Fasten thread to the joints of each wing, and then tie them together, leaving exactly the same space betwixt them as your knowledge in anatomy informs you existed there when the bird was entire; hold the skin open with your finger and thumb, and apply the solution to every part of the inside. Neglect the head and neck at present; they will receive it afterwards. Now fill the body moderately with wool, to prevent the feathers on the belly from being injured. You must recollect that half of the thigh, or, in other words, one joint of the thigh-bone, has been cut

away. As this bone never moved perpendicular to the body, but, on the contrary, in an oblique direction, as soon as it is cut off the remaining part of the thigh and leg, having nothing now to support them obliquely, must naturally fall to their perpendicular. Hence the reason why the legs appear considerably too long. To correct this, take your needle and thread, fasten the ends round the bone inside, then push the skin just opposite to it, and then tack up the thigh under the wings with several strong stitches. This will shorten the thigh, and render it quite capable of supporting the body without the aid of wire. Now is the time to put in the cotton for an artificial body, by means of the little stick, and then sew up the orifice you originally made in the belly, beginning at the vent. Lastly, dip your stick into the solution, and put it down the throat three or four times, in order that every part may receive it. When the head and neck are filled with cotton quite to your liking, close the bill as in nature. Bring the feet together by a pin, and then run a thread through the knees, by which you may draw them to each other, as near as you may judge proper. Nothing now remains to be added but the eyes; adjust the orbit to them as in nature, and that requires no other fastener. After this, touch the bill, orbit, feet, and former oil-gland at the root of the tail with the solution, and then you have given to the bird everything necessary, except attitude and a proper degree of elasticity. Procure any common, ordinary box; fill one end of it, about three-fourths up to the top, with cotton, forming a sloping plane. Make a moderate hollow to receive it, and place the bird in its right position. If you wish to elevate the wings, do so, and support them with cotton. If you wish to have the tail expanded, reverse the order of the feathers, beginning from the two middle ones, and when dry place them in their true order, and the tail will preserve for ever the expansion you have given it. In three or four days the feet lose their natural elasticity, and the knees begin to stiffen. When you observe this, it is the time to give the legs any angle you wish, and to arrange the toes. When the bird is quite dry, pull the thread out of the knees, and take away the needle, and all is done.

Insects for Cases.—Living insects, of which you wish to make “objects,” are instantly killed by putting them into a jar

of carbonic acid gas. This gives them no pain, and leaves them in the best state for mounting. As soon as they are dead, spread them in the shape desired, and fasten them down to the box with a corking-pin.

Skeleton Leaves.—Skeleton leaves may be prepared as follows :—

1. Steep the leaves in rain-water, in an open vessel, exposed to the air and sun. Water must occasionally be added to compensate the loss by evaporation. The leaves will soon putrefy, and then their membranes will begin to open; now lay them on a clean white plate filled with clean water, and with gentle touches take off the external membranes, separating them cautiously near the middle rib. When there is an opening towards the latter, the whole membrane separates easily. The process requires a great deal of patience, as ample time must be given for the vegetable tissues to decay and separate.

2. A more expeditious method is the following :—A table-spoonful of chloride of lime in a liquid state mixed with a quart of pure spring-water. The leaves or seed-vessels of plants must be soaked in the mixture for about four hours, then taken out and well washed in a large basin filled with water; after which they should be left to dry, with free exposure to light and air. Some of the larger species of forest leaves, or such as have strong ribs, will require to be left rather more than four hours in the liquid.

3. Perhaps the most effectual way is—First dip the leaves in boiling water, and then immerse them in dilute sulphuric acid, containing from 10 to 30 per cent. of the acid, according to the delicacy or coarseness of the leaf-structure. In a day or two use a pretty stiff bristle brush to the leaves, adding drop by drop a little saturated solution of bichromate of potassium. When the operation seems complete, wash the leaves carefully in ammoniated water, and finish with a little weak hypochlorite of calcium or chlorine water.

4. Dissolve 3 oz. of common washing-soda in a quart of boiling water, and add $1\frac{1}{2}$ oz. of fresh-slaked quicklime; boil it ten minutes. Pour into a pitcher, and let it stand a short time till settled; then pour the clear solution again into the pan, and let it boil. Add the leaves, and boil for say an hour, adding water to supply that evaporated. Take one of the leaves out

into a dish of clean water, and rub it gently between finger and thumb. If the outer covering will leave the mid-rib and veins, they will do ; if not, boil longer. *Bleach* thus :—One drachm of chloride of lime mixed in a pint of water, and allowed to settle ; pour off the clear liquid, and put in the leaves. Steep them till white—say about ten minutes. If they stay too long, they become brittle. Wash them in a dish of clean water, and dry in a book between blotting-paper.

When the “skeletons” are obtained by either of the four processes given above, they may be *plated* by being dipped into a very weak solution of phosphorus in bisulphide of carbon, dried, placed in a neutral solution of nitrate of silver for fifteen minutes, dried again, and lastly covered with dead silver in a small electro-plating apparatus. An almost equally beautiful result is produced if the “skeletons” are dipped into a clear boiling saturated solution of iodide of lead. When dry, they appear as if frosted with gold. If cautiously painted with a very concentrated alcoholic solution of mauve, skeleton leaves present the appearance of a magnificent and delicate casting in bronze. It is best to prepare leaves of one kind only at a time, as the time it takes to strip them differs considerably. The preparation of skeleton leaves is a very delicate and wearisome process, and should only be attempted by those happily constituted persons who can keep their patience under repeated failures.

Dried Flowers Preserved in their Natural Colours.—

Provide a vessel with a movable cover, and having removed the cover from it, fix over it a piece of metallic gauze of moderate fineness, and replace the cover. Then take a quantity of sand sufficient to fill the vessel, and pass through a sieve into an iron pot, where it is heated, with the addition of a small quantity of stearine, carefully stirred, so as to thoroughly mix the ingredients. The quantity of stearine to be added is at the rate of half a lb. to 100 lbs. of sand. Care must be taken not to add too much, as it would sink to the bottom and injure the flowers. The vessel with its cover on, and the gauze beneath it, is then turned upside down, and the bottom being removed, the flowers to be operated upon are carefully placed on the gauze and the sand gently poured in, so as to cover the flowers entirely, the leaves being thus prevented from touching each

other. The vessel is then put in a hot place, where it is left for 48 hours. The flowers thus become dried, and they retain their natural colours. The vessel still remaining bottom upwards, the lid is taken off, and the sand runs away through the gauze, leaving the flowers uninjured.

To Stock a Fresh-Water Aquarium.—There ought to be about three plants to every gallon of water, and two or three fishes, according to size, to every plant. Respecting the

Fishes suitable for the aquarium we may make the following remarks :—

Crusian or German Carp (*Cyprinus curassius*).—There are two kinds of them ; one is rather broader than the other. Its colour is gold-like, and is darker toward its tail. You ought not to have any, in a little aquarium, longer than two inches. Its back is bream-shaped, and it rises from the nape to a high arch along the line of the dorsal fin. It is a little subject to fungoid growths. It will live in dirty water, and is easily fed with bread crumbs ; but you must always be careful not to give it more than it can eat at once, because the bread on the bottom of the aquarium will render the water impure.

The Roach (*Cyprinus rutilus*) is very common.—It will also live in dirty water, and is very fit for an aquarium.

Prussian Carp (*Cyprinus carpio*).—It is easily separated from *C. curassius*, through its olive-brown colour, its beard round its mouth, and its tail and fins are darker. It is not as broad, but rounder.

Gold Carp (*Cyprinus auratus*), called so by Linnæus, the celebrated Swedish naturalist. It originates from China, its colour is gold, has the shape of *C. curassius*. When it is young it is silverlike. It is nice to look at, but very dull, and difficult to tame. They sometimes get poorly, and are covered with a white mould ; then you must remove it to a shallow basin, put a little salt on its back, and it will soon rub the mould off.

Minnow (*Cyprinus Phoxinus*), ought to be in every aquarium. An aquarium without minnows is no aquarium at all—it is a makeshift. With a shoal of minnows and a few Prussian carp, an aquarium may be considered fairly stocked, because there is really something to look at, something to amuse, and something to instruct. They are very sharp and amusing, always on the

move; but it is very strange that they live in an aquarium, because you never find them in other than quite clean water in their wild state. Their lower parts have a red colour during the summer-time, but fright will make them assume a pale fawn colour. The back and the top of the head have a dark olive-green colour. It is a little fish, but round. It will never grow longer than three to four inches. You ought never to have any longer than two inches in a small tank. It is very easy to tame; you can soon teach it to eat out of your hand.

The Bleak (*Cyprinus alburnus*) is also a fitting fish for a tank, especially if you pick small specimens. It is active in its movements, has a white, silverlike colour, and is continually on the move.

Perch (*Cyprinus fluviatilis*).—You must pick very small specimens. It is a very handsome fish, but must have quite clean water, and can consequently not live long in an aquarium.

Stickleback (*Gasterosteus*).—Should never be put into an aquarium with other small fishes. They are greedy and uneasy, and scarcely ever let the other fishes alone, often killing several. They must therefore be kept in a tank by themselves, or where there are only large fishes. They are, however, very interesting. Dr Lankaster, speaking of this fish, says:—"He has all the ways of other fishes, and many more besides. Look into your tank; see, there is one larger than the rest; he is clothed in a coat of mail like a knight of old, and it is resplendent with purple and gold. See how his eyes glisten, and with every movement present a new colour. He is a male fish, the king of your little shoal. He has important offices to perform. Presently, in the course of a few days, if you watch him, and are fortunate, you will see this wonderful little fish engaged in the most useful manner in building a nest. He first seizes hold of one little bit of weed, then of another, and carries them all to some safe corner, till at last his nest is built. Having done this, he gently allures his mate to his new-made home. Here she deposits her eggs, and having done this, resigns the care of them to our hero of the purple and gold, who watches over them with an anxiety that no other male in creation but the male stickleback seems to know. He fans and freshens the water with his fins, and at last, when the young are hatched, watches over their attempts at swimming with the greatest

anxiety. Nor is this habit confined to the fresh-water sticklebacks. A lady, writing to me from Aberdeen, and describing her aquavivarium, says, 'A fifteen-spined stickleback (*Gasterosteus spinachia*) constructed a nest on a piece of rock which was covered with a fine green seaweed, depositing the spawn first, then covering it with loose seaweed, and lacing all together with a long thread, composed, apparently, of some secretion. The fish afterwards, for about the space of three weeks, watched the nest, never leaving it at all save for the purpose of driving away the other fish when they approached too near. When a stick was introduced into the vicinity of the nest, the fish would fly open-mouthed to attack it, and would bite it with great apparent fury. At the expiration of the above-named time, the young fry made their appearance by hundreds, but I am sorry to say they soon disappeared, being devoured by the other fish, and caught by the tentacles of the sea-anemones. The mother-fish continued her attendance at the nest as long as any of the young fry were left.' "

If you see your fishes go up to the surface of the water in your aquarium, you have too many fishes; so you must either take away some, or put in some more plants. If you then find that the glass sides commence to be green, you are obliged to put in some snails or molluscs, which will in a short time clean the glass; but if you put in too many, they will commence to eat the plants, and then you have to remove some of them, especially *Linnæus stagnalis*, because that one likes the plants better than the green moss on the glass. The best wood of which to construct an aquarium is East India teak. It is generally very evenly grained, easily cleaned up for polishing, and, all things considered, it seems the most suitable. It may be obtained at shipbuilding establishments, or of coach-builders, at a little over the price of mahogany.

The Size.—For a small room, one to hold ten or twelve gallons of water is a good size. Suppose we get a piece for the bottom 2 ft. long by 14 in. broad, to finish 1 in. clear in thickness, and 4 ft. 4 in. to finish $1\frac{3}{4}$ in. square for the pillars. We yet require a piece for the top frame 6 ft. 4 in. long, $2\frac{1}{2}$ in. by $\frac{1}{2}$ in. thick. This is all the timber required for the tank. After planing up the bottom and squaring the sides and ends, run a cutting gauge round it $1\frac{3}{4}$ in. from the outside. This is the outside of the glass; then again a $\frac{1}{4}$ in. within, to

allow for the composition with which the glass is fixed. The groove must be a $\frac{1}{4}$ in. or $\frac{5}{16}$ in. deep. Next guage $\frac{7}{8}$ in. from the edge for the distance the vase mould is worked back. The pillars to be planed up to $1\frac{3}{4}$ in. square, and grooved on two sides in the centre $\frac{9}{16}$ in. deep, allowing the same for composition as in the bottom. This groove must be carefully filled up with a piece of deal before turning, and the length must be to show 12 in. of glass. Some care must be taken not to sink too much in turning, so as to get to the bottom of the groove. Leave a square $1\frac{1}{4}$ in. at the bottom, and $\frac{7}{8}$ in. at the top. The pillar, to get the tank water-tight, ought to be tenoned into the bottom $\frac{3}{8}$ in. deep. The best proportion of an aquarium is that the length ought to be double the width, and the height equal to the width; as, for example, if the length be 2 feet, the height and width should be 1 foot. There ought to be neither paint nor varnish inside the aquarium; they are injurious to the fish. The best time of the year for making an aquarium is April, May, or the beginning of June, because the fish and insects are very still in the cold season, so that they are accustomed to the small space.

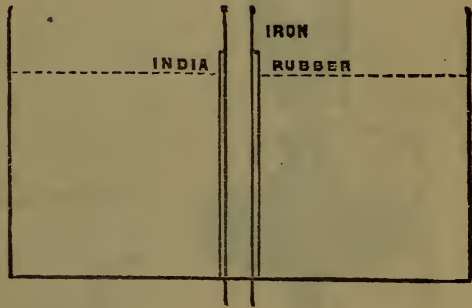

A gentleman, with some years' experience of a 40-gallon aquarium, says that zinc or iron should be most strictly kept out of contact with the water; iron is bad for the plants, and zinc is poisonous to the fish; the metal, being always impure, is dissolved more or less. You can try a varnish made by dissolving marine glue in wood naphtha made thin, and allowed to dry down to necessary consistence. This forms a capital varnish for the joints of aquarium over the lead cement. The varnish should be laid on thin for the first coat, as it then runs into small crevices; each coat to stand a day. All lac varnishes are attacked by the ammonia in the water. Should it be impossible to empty the tank or take out pipe, you might try a brass tube just large enough to drop over iron and zinc pipe, an indiarubber ring at bottom coming just below edge of brass tube to exclude current of water setting up between the

tubes ; or, perhaps better still, a piece of indiarubber tubing slipped over the iron and zinc pipe. Portland cement is also injurious to fish. Roman cement should be exclusively used for rock-work, which should be soaked in water for a month before being placed with the fish.

Aquarium Fountain.—A table or aquarium fountain may be made thus :—The design is simple, requiring no piston, weights, or other mechanism ; it is, in fact, a “ syphon with an enlarged bend.” The experiment was first tried with a pickle

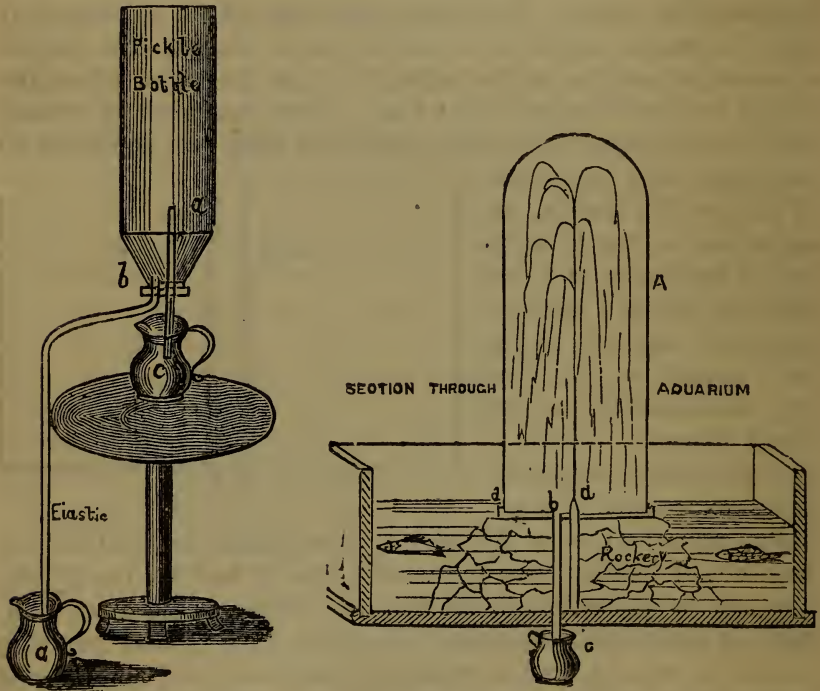

bottle and two bits of tube. The air must be sucked out till the water, rising through *a* out of the jug *c*, begins to run down the tube *b* ; the fountain will then play till all the water in *c* is exhausted, or as in the second engraving (representing the actual fountain). *A* is a glass shade fitted air-tight into a tray of tin, or other material ; *a* is a tube with a nozzle, having a hole about 1-16th of an inch ; a piece of glass tube drawn to a point will do very well ; the lower end should nearly touch

the aquarium, or other reservoir ; *b* is a tube, the top of which should be nearly flush with the tray as shown ; say 6 in. may be metal or glass, the rest may be elastic, or any other tube, and may convey the waste water through the bottom of the aquarium, or over the top, or out of a window. The weight of the water in the longer arm of the siphon *b* produces a partial vacuum in *A*, the water consequently rises through *a*.

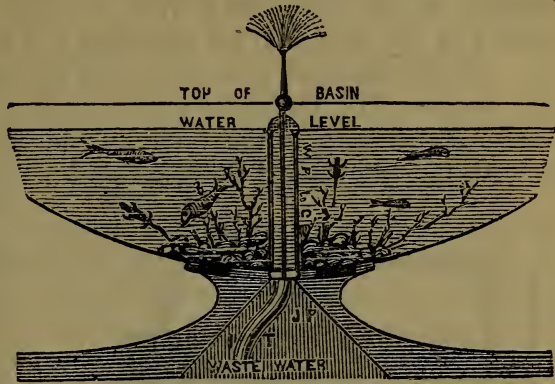

1. In this plan the pipe conveying the water from the piston to the jet is india-rubber, fastened to a piece of brass tubing about $1\frac{1}{2}$ in. long on top of piston, the other end being fastened to the jet-pipe, as shown in present sketch. The running of water is also shown. IT, india-rubber tube, connecting JP, jet-pipe, with top of piston. WP, waste-pipe, conveying the water from B down outside of jet-pipe to cylinder. It may be open or closed at top ; if closed, the cap must be drilled full of little holes. The water in B has to rise to top of this waste-pipe, thus keeping a good supply of water for fish. The tube WP may be hidden by artificial rocks.

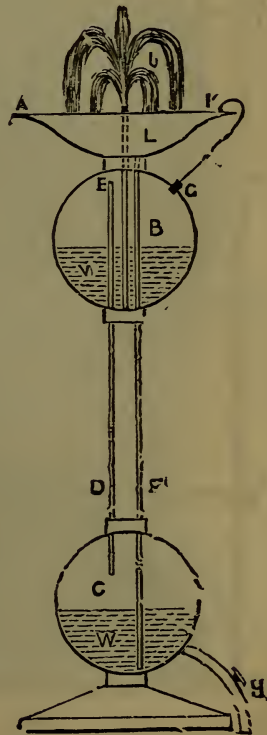

2. In this diagram, A is a porcelain or other basin, B and C are two glass globes connected by two tubes D and F, of which D commences near the top of the upper globe, and ends near the top of the lower one ; and F commences at L in the basin A, and ends near the bottom of the lower globe. The third tube E commences in the jet at J, and ends near the

bottom of the upper globe. G is a plug fastened by a string at K; H is a stopcock leading out of the lower globe to the outside of the aquarium; WW is water. This fountain is placed in the aquarium till the water is a little above the vessel A. When you wish it to play, pull out the plug G, and open the stopcock H; the water then rushes in at G till it is nearly level with the top of the tube D, and then the plug G is replaced, the stopcock H is closed, and the jet J, which must also

have a stopcock, is opened; the water then rushes down the tube F into the lower globe, the water forces the air up the tube D into the upper globe, and the compressed air forces the water in the upper globe through the tube E, and through the jet J. Then when the water in B is exhausted, shut up the jet, pull out the plug G, and open the stopcock H, &c.

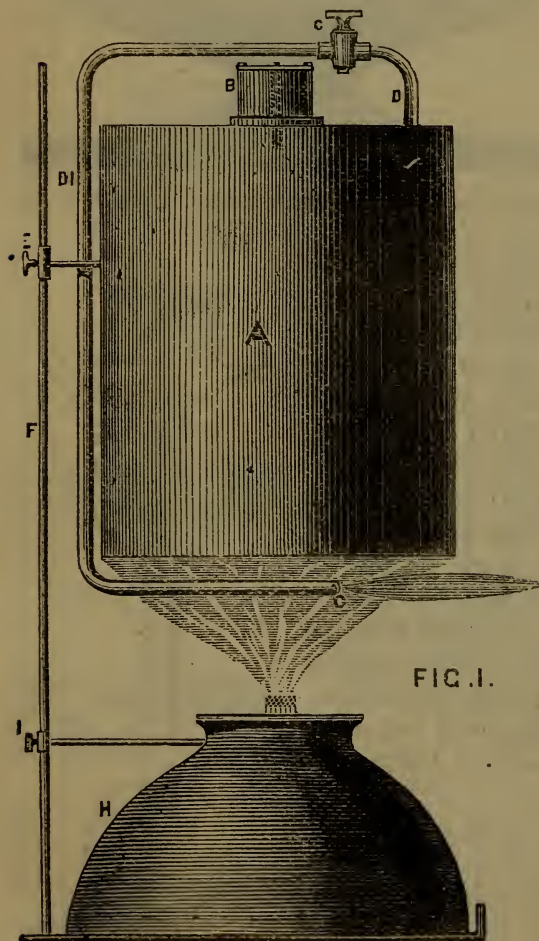

FIG. I.

Spirit Blow-Pipes.

—Two spirit blow-pipes, figs. 1 and 2, are described below: Fig. 1 has a boiler, A, made of copper, in the most suitable shape. It must be air-tight. B is a safety-valve, which is kept close by a spiral

spring inside. The valve B must be made with a socket, the socket being brazed on top of boiler; it must be made to screw off and on; a pipe, D, must then be brazed in at the top, a stop-

cock, C, must be put on the pipe, and another pipe, D1, must be connected on the end of stopcock, and brought a little more than half-way under the bottom of boiler. If required for making gasfitters' joints, a small round hole in the end G will answer best; if for melting sheet-brass, the end made flat will do. It would be a good plan to get jets to screw on and off. A socket should be brazed on the side, with a piece of iron tapped into it; the piece of iron should be tapped at both ends, and a socket with a thumbscrew made to screw on to it. A piece of round bar-iron or gas-pipe should be put for a slide F, and a piece of sheet iron should be put at the bottom for F to be fixed into, and for the lamp H to stand on. I is a regulator to turn the wick up and down.



A vent-hole should be left in the top of lamp, the boiler should be filled up to within 1 inch of the top with methylated spirits, and the lamp may be filled with the same. Care must be taken to have everything sound, and an indiarubber washer should be put on the under side of rim of safety-valve; the valve can be taken out to put spirits in. Stopcocks can be got about 1 in. long.

FIG. 2.

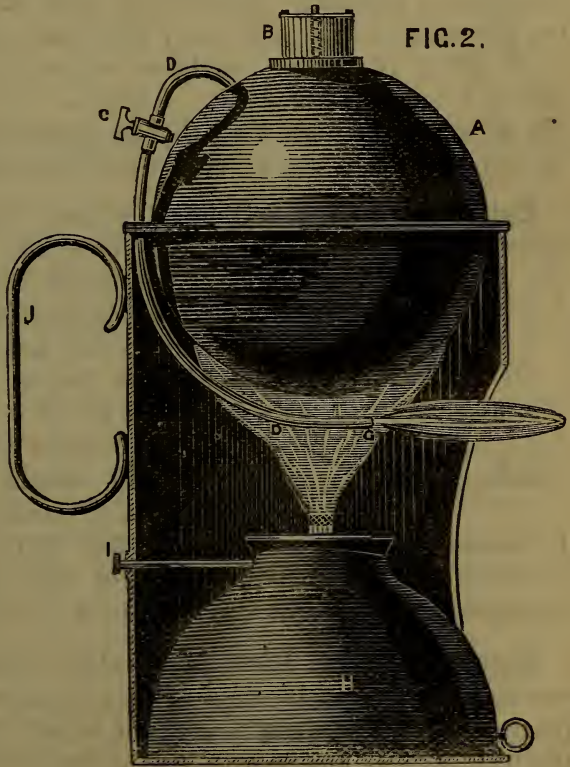

Fig. 2 is another style of blow-pipe.

A frame of sheet iron is made similar to a pint pot, only the lower part of the front is cut away to make room to put the lamp H in, and to allow the flame to come out. A is the boiler, made of two pieces of copper, with both edges closed to

form a rim outside ; the boiler should be made to fit the frame, a safety-valve, B, should have a socket brazed in at the top of boiler ; the valve must be made to screw in and out. A spiral spring must be put to keep the valve closed ; a pipe, D, must be put in as near the top as possible ; a stopcock, C, must be put as near as it can be, so as to come above the frame that holds the lamp and boiler ; a pipe, D1, must be put to conduct the gas down to the bottom, a little more than half-way under the boiler ; a lamp, H, must then be put under, leaving about an inch between the boiler and lamp. A small hole must be made in the back of the frame for the regulator I to come through ; the pipe should terminate the same as in fig. 1 ; a small ring should be put on the bottom of fig. 2 of the lamp to draw it out when required. Both boilers must be supplied by taking out the safety-valve, and nearly filled with methylated spirits.

A Spirit Blow-pipe, made on either of the above plans, effects a considerable saving of spirits. On lighting the lamp, the cock can be turned off till the spirits are hot ; it can then be turned on, and the flame can be regulated as required.

Spirit Blow-Pipe.—It is all copper, and cylindrical ; but shown in section with lid on. The pipe or tube, as will be seen, forms the handle, and is put in operation by igniting the spirits, which are up to the dotted lines, and extinguished by simply putting on the lid ; it can be made to meet the requirements of almost any class of artizan. It is very simple, compact, easy to manage, and stands on its own bottom.

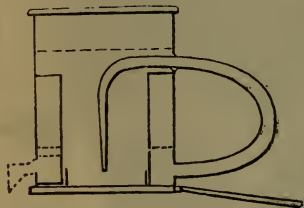

By connecting another vessel for the regular supply of spirits, it can be kept going for any length of time, and by other simple arrangements the flame can be placed in any direction.

Amateur's Gas Blow-Pipe.—This may be easily constructed. All that is requisite is a common blow-pipe and a piece of brass tube about 3-16ths of an inch in diameter. Bend the tube slightly at one end, and at the shoulder make a hole so that the small end of the blow-pipe may pass through into the larger tube, to come about flush with its end. Solder the joint to make it air-tight, and fasten pieces of vulcanized india-rubber tube of any convenient length to each of the other ends

of the brass tubes, and the instrument is complete. Let gas pass through the larger tube and ignite it; now blow through the blow-pipe, and by regulating the gas-flame you can easily obtain any degree of heat you wish, as well as a very steady flame of any shape.

Few who have once used it will willingly go back to the single tube or ordinary blow-pipe. The fine end of the blow-pipe should be about the centre of the larger or gas tube.

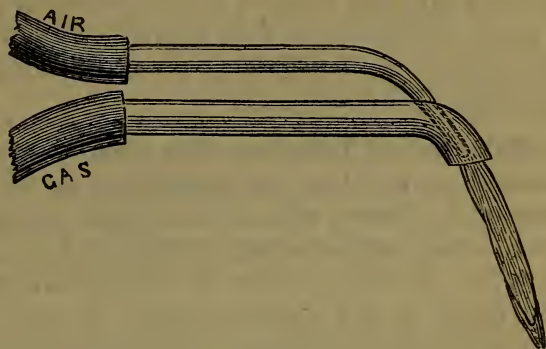

Matches without Phosphorus. — The following mixtures will be found to answer satisfactorily:—1. Divide a solution of copper into two equal parts; supersaturate one with ammonia and the other with hyposulphate of soda; mix them together, and dry the precipitate, which will fall. Mix this with strong glue and a small quantity of powdered glass. Lucifers made with this mixture will ignite on any rough surface. 2. Take from four to six parts of chlorate of potash, and two parts each of bichromate of potash, and of oxide of iron or lead, and mix with three parts of strong glue. For an igniting surface, take from four to six parts of oxide of either iron, lead, or manganese, two parts of glass-powder, and from two to three parts of strong glue or gum. *These matches will ignite only on the friction surface thus prepared.* Another German chemist uses for the match-heads a mixture of chlorate of potash and a salt which he describes as a compound of hyposulphurous acid with soda, ammonia, and oxide and sub-oxide of copper. He forms this compound by dividing a solution of copper into two equal parts, supersaturating one of them with ammonia, and the other with hyposulphate of soda; then mixing the two solutions, and stirring the mixture well. A violet powder precipitates; one part of it is to be mixed with two parts of the chlorate of potash, and a small quantity of pounded glass. Lucifers made in this way, however, will

ignite on any rough surface, even more easily than the common kind.

Use of Alum in Iron Safes.—In fire-proof safes there is a certain space filled with powdered alum. When the heat reaches this, the water of crystallization is driven off, by which a great absorption of heat is produced, and the temperature of the interior of the safe kept proportionately low. This is the principle of Milner's safe.

Chlorate of Potash.—Mix 3 lbs. of common salt, 2 lbs. of manganese at 8d. or 9d., and 2 lbs. by weight of oil of vitriol, previously diluted with about 2 pints of water, and allowed to cool; distil into a retort containing 6 oz. pearl ash, dissolved in 3 lbs. of water; when the distillation is finished, evaporate the liquid in the receiver slowly in the dark. The chlorate will crystallize in flakes. Of course these quantities may be altered to suit the convenience of the operator.

Spontaneous Combustion of Oil Rags.—When cotton waste, or shavings are saturated with oil, a large surface is exposed to the action of the air; and if the oil has the property of absorbing oxygen, it may absorb the gas so rapidly as to take fire. This is the way in which spontaneous combustion takes place. As petroleum naphtha does not absorb oxygen, it never takes fire by spontaneous combustion.

Lubricating Composition.—Good lard, 16 oz.; bees'-wax, 2 oz.; olive or sperm oil, 40 oz.; flowers of sulphur, 8 oz.; black-lead, 4 oz. (in powder, and free from grit); white soap, 1 oz.; all of the best quality, and to be well incorporated.

Crucibles of Lime.—In these experiments a clay crucible of somewhat larger capacity than the desired lime one is filled with common lampblack, compressing the same by stamping it well down. The centre is then cut out with a knife until a mere shell or lining of lampblack is left firmly adherent to the sides of the crucible, and about half an inch or less in thickness, according to the size of the crucible; this lining is now well rubbed down with a thick glass rod until its surface takes a fine glaze or polish, and the whole cavity is then filled up with finely-powdered caustic lime, and pressed down as before, and a central cavity cut out as before; or the lime-powder may

be at once rammed down round a central core of the dimensions of the intended lime crucible. This lime lining is naturally rather soft before being placed in the furnace, but upon heating agglutinates, and forms a strong and compact crucible, which is prevented acting upon the outer one by the interposed thin lampblack layer, and at the end of the experiment generally turns out as solid and compact as those made in the lathe. Experiments made with such crucibles, even up to dimensions containing several pounds of metal, have proved them extremely well suited for these operations, and doubtless similar crucibles could be made lined with magnesia or alumina as required. In some cases ordinary blacklead crucibles, lined with powdered lime, magnesia, or alumina, might possibly be found to answer.

Chemical Balance.—A thin piece of fir-wood, not thicker than a shilling, and a foot long, and $\frac{1}{2}$ in. broad, is divided into twenty parts—that is, ten parts on each side of the middle;

these are the principal divisions, and each of them is subdivided into halves and quarters; across the axis is fitted one of the smallest needles, and fixed to its place by sealing-wax. The fulcrum is a piece of brass, the middle of which

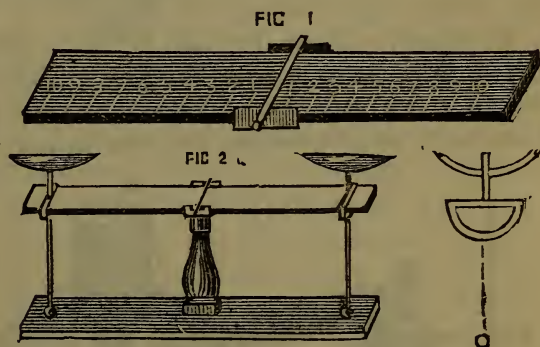

lies flat upon the table. The two ends are bent at right angles, so as to stand upright, and are ground flat upon a hone. They stand above the surface of the table only 1-5th of an inch. This balance will weigh the minutest quantity, even the 1200th of a grain. A grain weight is placed on one division, and the object on the other; the proportion of the two will indicate the weight of the latter. The other is on the same principle; the scales are of ivory, from which a small bullet is suspended by a wire; the process of weighing as in the former balance.

Laughing Gas.—Laughing gas (nitrous oxide) is prepared from nitrate of ammonia by heating it in a glass retort, or in a

clean dry Florence flask, with a bent glass tube attached. The stem of the retort or tube must dip into a pneumatic trough, on the shelf of which the jar to collect the gas is placed. A solution of 2 oz. of sulphate of iron in one gallon of water, warm, should be used in lieu of water, as it purifies the gas. On the application of heat, the gas passes over into the jar,

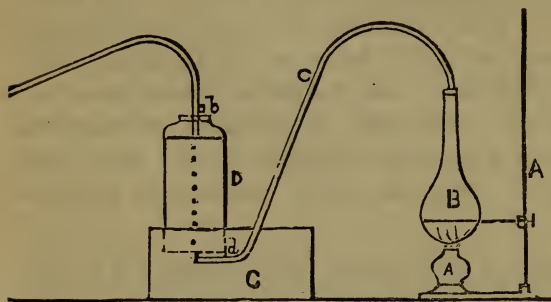

driving, of course, the water out. An ordinary gas jar will do to collect the gas, in the mouth of which a cork, with a piece of glass tubing, with an indiarubber pipe attached, passed through it, is inserted. A stopcock must be attached to the pipe to prevent the escape of gas till wanted.

To inhale.—Place the tube in the mouth, empty the lungs of air, stop the nostrils with the fingers, and then inhale the gas, say for a few seconds. The effects vary with the constitution. Combative people should not take it, nor should it be administered to females.

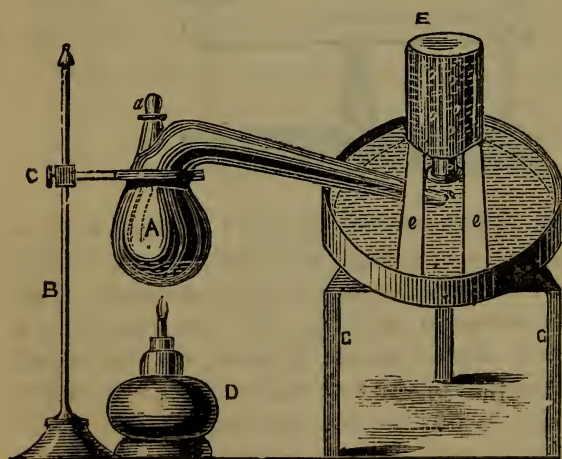

The source of heat must be withdrawn immediately any white fumes appear in the retort; and care should be taken to control those under the influence of this gas, as they are then utterly unable to do so themselves. The frequent use of nitrous oxide is not

conducive to health. A, retort; B, Florence flask; C, pneumatic trough; D, gas jar. *a*, spirit-lamp; *b*, stopcock; *c*, conducting pipe; *d*, shelf of strength.

Another mode of preparing.—An ordinary retort, purchasable at any glass-house, is shown at A. The stand for the retort is seen at B, with, C, a screw to fix the ring in which the retort rests; D is the spirit-lamp; E is a bottle containing water, into which the gas rises, having escaped at the mouth of the retort at *f*, and passes through the water in the trough F into the bottle E, in little bubbles, driving the water out of the bottle as the gas rises to the top; GGGGG is a table of triangular form, supporting the trough F. Into the retort A must be placed some of the salt called nitrate of ammonia; then set light to the spirit-lamp under the retort or Florence flask; a gas will be given off which will pass down the tube of the retort, under the water, and thence rise into the bottle, forcing the water out as it rises.

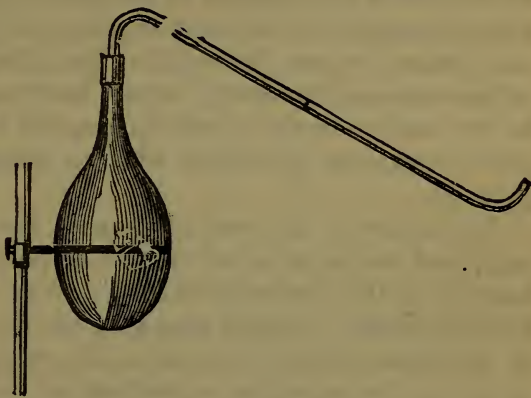

This process of collecting gas is called “collecting over water.” When the bottle is perfectly empty of water, it is full of nitrous oxide—the gas required; and in taking the bottle from the water, the stopper should be placed in before letting the mouth of the bottle come beyond the surface of the water, or else the gas will escape. As many bottles of gas as are required can be prepared in this manner.

Laughing gas is now used as an anodyne by the dentists.

Nitrate of Potash.—New Process.—It has been ascertained, by M. Condurie, that nitrate of potash may be formed from nitrate of soda, by a very simple process. This consists in mixing concentrated and equivalent solutions of nitrate of soda and chloride of barium, or sulphate of baryta, which precipitates the sparingly soluble nitrate of baryta: washing the latter and boiling it with sulphate of lead, which forms nitrate of lead and sulphate of baryta; and boiling the nitrate of lead with sulphate of potash, which forms the required nitrate of potash, and reproduces the sulphate of lead.

To Clarify Impure Water.—The chemical agent to effect this object is a solution of the neutral sulphate of peroxide of iron ($\text{Fe}_2\text{O}_3 \times 3\text{SO}_3$), which is to be added, in a very diluted state, to the water intended to be operated upon.

The proportion in which the solution of neutral sulphate is to be added to the water, for the purpose of the invention, must be determined by the amount of the impurity contained therein. The suitable proportions must therefore be ascertained, by careful experiment carried on from time to time, if it should be found that the impurity of the water varies. The addition of more or less of the neutral sulphate will not materially affect the process beyond the evident fact, that too dilute a solution of the salt would probably either leave some of the impurities in the water, or the purifying process would be more costly than would be necessary for the complete success of the process.

The water to be purified may be run into a tank or reservoir, and the solution of neutral sulphate added thereto as it runs in, so that the solution may be well mixed with the water to be purified. A short time after the neutral sulphate is added to the impure water it becomes decomposed, and forms, with some of the impurities contained in the water, a basic salt, which is insoluble in water. The solid and insoluble particles of this new salt are precipitated, and, together with the impurities contained in the water, form a sedimentary deposit, from which the purified water may be allowed to run off, leaving behind the sedimentary deposit in the tank or reservoir. A repetition of this precipitation process on other bodies of water which may be run into the same tank or reservoir will cause additional deposits, which, when they have been allowed to accumulate to a sufficient depth in the reservoir, may be collected, and removed from the reservoir from time to time. This process has been patented by Mr Edward Newton.

Refining Olive Oil.—The best olive oil, in its crude state, possesses that peculiar bland flavour which fits it for the table, and which appears to arise principally from the quantity of mucilage and water, either held in solution, or mechanically mixed with it. By keeping one or two years in jars, a considerable portion of the mucilage and water subsides, which renders such oil not only cheaper, but better qualified for yield-

ing a greater proportion of pure oil than that which is recently expressed from the fruit. Two or three gallons skimmed from the surface of a large jar that has remained at rest for twelve months or upwards is preferable to any succeeding portion from the same jar, and may be considered the cream of the oil. Having procured good oil in the first instance, put about one gallon into a cast-iron vessel capable of holding two gallons ; place it over a slow, clear fire, keeping a thermometer suspended in it ; and when the temperature rises to 220° , check the heat, never allowing it to exceed 230° , nor descend below 212 , for one hour, by which time the whole of the water and acetic acid will be evaporated. The oil is then exposed to a temperature of 30° to 36° for two or three days (consequently winter is preferable for the preparation, as avoiding the trouble and expense of producing artificial cold). By this operation a considerable portion is congealed ; and while in this state, pour the whole on a muslin filter, to allow the fluid portion to run through ; the solid, when re-dissolved, may be used for common purposes. Lastly, the fluid portion may be filtered once or more through newly-prepared animal charcoal, grossly powdered, or rather broken, and placed on bibulous paper on a wire frame, within a funnel, by which operation rancidity (if any be present) is entirely removed, and the oil is rendered perfectly bright and colourless.

Refining Lard Oil.—Bancroft's Process.—Stir the oil with a lye of caustic potash of the specific gravity of 1.2 . A sufficient quantity has been added when a portion begins to settle down at the bottom. After twenty-four hours the clear oil should be decanted from the soapy sediment and filtered. It may be bleached by using a saturated solution of hydrochloric acid with bichromate of potash.

Petroleum Stove.—A neat and compact arrangement for burning mineral oils, as a substitute for gas, in small cooking-stoves, has recently been adopted in the United States. Although such stoves are not likely to come into use in this country for cooking purposes, they might be found convenient in chemical laboratories, where gas is not readily obtainable. The base of the stove is an open-work cast-iron pediment, standing on three feet, and holding a tin can, from the centre of which rises a wide wick, passing through a drum, which

serves as a base for a funnel-like chimney. The case of this chimney is of tin, lined throughout with fine brass gauze. At the bottom the chimney-case has openings on the sides for the admission of atmospheric air. The outer cylinder is of Russian sheet-iron, and is surmounted by a cast-iron ring, having upward projecting points to sustain the cooking utensil. These points elevate the vessel sufficiently to allow the heat from the flame to circulate above the top of the stove around the sides of the kettle. The can is filled with naphtha, benzine, kerosene, or petroleum, the chimney removed, and the wick lighted. The chimney is then replaced, and the stove is ready for operation. If the wick is kept down below the point where the flame would produce illumination, there will be no deposits of carbon on the vessel used for cooking, and the gauze, with the plentiful supply of oxygen through the chimney apertures, will yield intense heat.

Sealing-Wax.—The following are the materials and proportions for making red and black sealing-wax :—

For black—

Venice turpentine	4½ oz.
Shellac	9 oz.
Colophony	½ oz.
Lampblack mixed to a paste with oil of turpentine, a sufficient quantity.	

For red—

Venice turpentine	2 oz.
Shellac	4 oz.
Colophony	1 oz.
Chinese vermilion	1½ oz.
Magnesia, moistened with oil of turpentine ...	1½ dr.

For the best red—

Venice turpentine	4 oz.
Shellac	7 oz.
Cinnabar	4 oz.
Carbonate of magnesia with oil of turpentine ...	1½ dr.

Any of these would also do for white sealing-wax, by substituting flake white for the lampblack, vermilion, and cinnabar. Adding a small quantity of fine gum benzoin will give them an agreeable perfume.

Lime Water is made by adding 2 oz. of slaked lime to 1 gallon of water, and shaking it well for a few minutes. After twelve hours the excess of lime will have subsided, and the lime water may be drawn off by means of a syphon as required.

Sugar, Use of Lime in Extracting.—Peligot long ago demonstrated that, owing to the insoluble nature of the compound formed of lime with sugar, the former substance would be a most valuable agent in the manufacture of the latter. Peligot's suggestion is now being carried out on a large scale in MM. Schrötter and Wellman's sugar-factory at Berlin. The molasses is mixed with the requisite quantity of hydrate of lime and alcohol in a large vat, and intimately stirred for more than half an hour. The lime compound of sugar which separates is then strained off, pressed, and washed with spirit. All the alcohol used in the process is afterwards recovered by distillation. The mud-like precipitate thus produced is mixed with water, and decomposed with a current of carbonic acid, which is effected in somewhat less than half an hour. The carbonate of lime is removed by filtration, and the clear liquid, containing the sugar, evaporated, decolourized with animal charcoal, and crystallized in the usual manner. The sugar furnished by this method has a very clear appearance, and is perfectly crystalline. It contains, according to polarization analysis, 66 per cent. of sugar, 12 per cent. of water, the remainder being uncrystallizable organic matter and salts. The yield, of course, varies with the richness and degree of concentration of the raw material; on an average, 30 lbs. of sugar were obtained from 100 lbs. of molasses.

Prince Rupert's Drops.—The properties of unannealed glass are beautifully shown in these scientific toys. They are made by dropping melted glass into water, which takes a long oval form, tapering to a point at one end. While the body of these drops will bear a smart stroke from a hammer without fracturing, if a portion of the smaller end is snapped off, the whole mass will be broken into an almost palpable powder with a violent shock. Professor Faraday used to illustrate the incompressibility of water by placing one of these drops in a phial of water, the concussion from the disruption of the drop shattering the glass bottle. *Another interesting experiment* with the same toy is this:—In place of water, fill the phial with melted resin, and when this has solidified, nip off the end of the glass drop. The bottle is broken as before, and the mass of resin is deeply fissured throughout its length. The drop is found as a kernel, loosely aggregated together, but

easily detached from the resin entire. When broken in pieces, the fragments will be seen to have the form of a cone on an hemispherical base, like some forms of hail.

Printers' Ink.—A capital ink is made as follows :—Put linseed oil into an iron pot capable of holding at least two or three times the quantity introduced, heat it over a fire until a dense vapour arises from it ; then, having removed the pot from the fire, apply a lighted match, attached to the end of a stick, to the surface of the oil, when the vapour will inflame ; allow it to burn for half-an-hour or more, until on taking out a small quantity of the oil, it is found to be thick and tenacious ; the flame is then to be extinguished by putting a cover over the pot, and keeping tightly covered. To 6 quarts of oil, thus prepared, add gradually 6 lbs. of black resin, and dissolve it by the aid of heat, then add, in small quantities at a time, $1\frac{3}{4}$ lbs. dry yellow soap, cut into slices, and effect the combination by stirring and the application of heat ; this is the varnish of which the ink is to be made, and on the careful preparation of which the quality of the ink much depends ; this is to be mixed with $2\frac{1}{2}$ ounces of ground indigo, the same quantity of ground Prussian blue, 4 lbs. mineral lampblack, and $3\frac{1}{2}$ lbs. of the best vegetable lampblack, and the whole ground together into a perfectly smooth and uniform paste.

Ink of different colours is made by mixing the varnish with various dry pigments, such as vermilion, redlead, Indian red, chrome yellow, chrome red, verdigris, Prussian blue, &c. &c. These colours are ground up in the varnish with a stone and muller.

In the above process there is considerable danger of the oil boiling over (which would be a serious affair), and wherever it is practicable, the best plan is to buy it of a good printing-ink manufacturer.

To Restore Faded Ink.—Ink faded from age may be revived by damping the manuscript with very weak vinegar, and allowing it to remain damp for an hour or two. Then carefully wash the paper over with a solution of prussiate of potash. If the writing does not appear clear at once, expose the paper to the air for a few hours, keeping the whole slightly damp.

Inks.—*Black Ink.*—Excellent kind of writing ink may be obtained by any of the following methods :—

1. (Without galls), Logwood chips $\frac{1}{4}$ lb. ; boil in three pints of water down to 2 pints, strain well, and let it cool ; then add 25 grains of bichromate of potash. Stir well, add a little gum arabic and a few cloves.

2. (The same in different proportions.) Take 1 lb. of logwood chips, and pour on a pint of boiling water ; let it stand until all the colour is extracted ; then strain it, and add to the solution about a thousandth-part of chromate of potash, or sufficient to make it the proper colour. This mixture does not require the addition of gum or anything else to give it consistency ; it will corrode steel pens, and is a fine permanent black.

3. Take bruised Aleppo galls, 2 oz. ; green copperas, 3 drs. ; clean rain-water, 1 quart ; and best gum arabic, 3 drs. Mix in a bottle, and it will be fit for use.

4. *A fine Blue-black.*—Take bruised Aleppo galls, $5\frac{1}{2}$ oz. ; bruised cloves, $\frac{1}{4}$ oz. ; sulphate of iron, $1\frac{1}{2}$ oz. ; sulphate of indigo, in the form of a slightly acid paste (sulphindylate of potash ?), $1\frac{1}{2}$ oz. ; sulphuric acid, 35 minims ; *cold* rain-water, 40 oz. Macerate the galls and cloves in 20 oz. of the water for a week ; decant the liquor, and add to the residue of the solid ingredients 10 oz. of the water, with which continue the maceration for four days ; then decant as before, and repeat the maceration with the remaining 10 oz. of water for another period of four days. Mix now the whole of the liquors, recovering from the galls all that can be obtained by squeezing them in a cloth, and afterwards filter. To this add first the sulphate of iron, then the sulphuric acid, and lastly the indigo paste. Care must be taken that the indigo does not contain much free acid. This is also a good *copying* ink.

Indestructible Ink for resisting the action of corrosive substances : Twenty-five grains of copal in powder are to be dissolved in two hundred grains of oil of lavender, by the assistance of a gentle heat, and are then to be mixed with two and a half grains of lampblack, and a half grain of indigo.

6. *Copying Inks.*—1. Three parts by weight of white glycerine ; three parts of purified white honey, best quality ; 10 parts of violet, black, or other coloured ink. Mix up well, and leave the mixture to settle two or three days before using. 2.

Four parts by weight of white glycerine ; four parts of purified white honey, best quality ; ten parts of Robertson's ink ; a half part of powdered gum arabic. Add one or two drops of strong solution of bichloride of mercury to prevent deterioration of the ink ; stir up well, and leave it to settle for two or three days before using. If it should be found, in taking copies from ink according to recipe No. 1, that thicker characters are produced than those of the original, the proportions of glycerine and honey may be respectively reduced to two parts of each, or another quarter by weight of one part powdered gum arabic may be added.

Indelible Ink.—1. A very good *indelible black ink*, capable of resisting chlorine, oxalic acid, and ablution with a hair pencil or sponge, may be made by mixing some of the ink made by the preceding prescription, with a little genuine China ink. It writes well. Many other formulæ have been given for indelible inks, but they are all inferior in simplicity and usefulness to the one now prescribed.

Solution of nitrate of silver thickened with gum, and written with upon linen or cotton cloth, previously imbued with a solution of soda, and dried, is the ordinary permanent ink of the shops. Before the cloths are washed, the writing should be exposed to the sunbeam, or to bright daylight, which blackens and fixes the oxide of silver. It is easily discharged by chlorine and ammonia. 2. A good permanent ink may be made by mixing a strong solution of chloride of platinum with a little potash sugar, and gum to thicken. The writing made therewith should be passed over with a hot smoothing-iron to fix it. 3. Nitrate of silver, 1 to 2 drs. ; water, $\frac{3}{4}$ oz. ; dissolve, add as much of the strongest ammonia-water as will dissolve the precipitate formed on its first addition, then further add mucilage 1 or 2 drs., and a little sap green to colour. Writing executed with this ink turns black on being passed over a hot Italian iron. 4. Asphaltum, 1 part ; oil of turpentine, 4 parts ; dissolve, and colour with printers' ink. Very permanent. 5. 20 grains of sugar dissolved in 30 grains of water, and the addition to the solution of a few drops of concentrated sulphuric acid ; the mixture is then heated, when the sugar is carbonized by the action of the acid. It is said that the writing is not only of a solid black colour, but that the acid resists the action of chemical agents.

Permanent Ink for Writing in Relief on Zinc.—Bichloride of platinum, dry, one part; gum arabic, one part; distilled water, ten parts. The letters traced upon zinc with this solution turn black immediately. The black characters resist the action of weak acids, of rain, or of the elements in general, and the liquid is thus adapted for making signs, labels, or tags which are liable to exposure. To bring out the letters in relief, immerse the zinc tag in a weak acid for a few moments. The writing is not attacked, while the metal is dissolved away.

Blacking.—*Liquid Blacking.*—1. Boil 1 oz. each of powdered galls, starch, and copperas, and 2 oz. of white Castile soap, with 2 quarts of water; then strain and mix with 3 oz. of fine ivory-black and 6 oz. of molasses. 2. Ivory or bone black, 2 lbs.; neat's-foot oil, 4 oz.; mix, and add 3 quarts of sour beer or vinegar, and a spoonful of any kind of spirit; stir till smooth, add 2 oz. of oil of vitriol, and sprinkle on it $\frac{1}{2}$ dr. powdered resin. Then boil together 3 pints of sour ale with a little log-wood, and $\frac{1}{4}$ ounce of Prussian blue, 3 oz. of honey, and 8 oz. of treacle; mix, but do not bottle for two or three days. 3. Ivory or bone black, 8 oz.; brown sugar or treacle, 8 oz.; sweet oil, 1 oz.; oil of vitriol, $\frac{1}{2}$ oz.; vinegar, 2 quarts; mix the oil with the treacle, then add the oil of vitriol and vinegar, and lastly the black.

Paste Blacking.—Powdered bone-black is mixed with half its weight of molasses, and one-eighth of its weight of olive oil, and to this is afterwards added one-eighth of its weight of hydrochloric acid, and one-fourth of its weight of strong sulphuric acid. The whole is to be then mixed up with water into an unctuous paste.

Blacking for Harness.—Take 4 oz. of black resin, and put it in a glazed pipkin over a slow fire; when melted, add 6 oz. of beeswax. When the beeswax is melted, take it off the fire, and add 1 dr. of Prussian blue in powder and 1 oz. of lamp-black; stir till perfectly mixed, and add turpentine until it becomes a thin paste, then let it cool. When required to be used, rub it over the harness, and polish with a soft brush.

Piecing Indiarubber.—Make a long bevel on the ends you wish to join (with a sharp, rough-edged knife and water), scrape the bevels rough with the edge of the knife, and when quite dry, give each a coat of indiarubber solution—say 1 oz. of

rubber, not vulcanized; to 5 oz. of turpentine. When the first coat is dry, give it another; and when that is dry, he may put the two ends together. It is impossible to make a firmer joint than by this method.

Vulcanized Indiarubber.—It is impossible to manufacture vulcanized indiarubber that shall be free from odour, and not liable to become rotten. With regard to smell, a good deal can be done towards making it agreeable by exposure to the atmosphere, and by desulphurization; but the best plan is to scent it in the manufacture, and so disguise the natural smell. With regard to rubber becoming rotten or decomposing, it is a question of manufacture and exposure to the sun's rays, which is the most powerful agent in effecting the decomposition. The red rubber is as liable to become rotten as any other of the same specific gravity. It also has the ordinary odour of vulcanized indiarubber, unless artificially scented.

Bones for Manure, Preparation of.—Illienkof, a Russian chemist, gives the following process, which, it is said, has received the approbation of Liebig:—The author mixes 4000 kilos. of ground bones with 4000 kilos. of wood ashes containing 10 per cent. of carbonate of potash, and adds 600 kilos. of quicklime. This mixture he places in a tank or fosse with water sufficient to make the whole moist. In a short time the bony matter is completely disaggregated by the caustic potash, and the pasty mass formed is then taken from the tank, dried, mixed with an equal weight of mould, and is then ready to be distributed.

Chimney Lamp.—Some chimneys will last for months, while others, apparently as sound and good, will break after a short use, without any apparent cause. The great cause of their being brittle and breaking so easily lies in the material they are made from. There is "shoddy" in glass as well as in cloth. A great many manufacturers make chimneys from silicate of lime instead of silicate of lead. The glass made from the silicate of lime has about the following proportions:—Sand, 100; soda, 45; lime, 20 to 25; nitre, 7 to 10. Lime being a non-conductor of heat, the chimney will not bear the expansion caused by the heat; and if, by gradual heating, the chimney does not break on the lamp, a few times heating

makes it so brittle that it breaks with the least effort at cleaning it, no matter how much care is used. The silicate of lead has about the following proportions:—Sand, 100; lead, 40 to 50; soda, 20 to 25; nitre, 10 to 15. Lead being very ductile, and a good conductor of heat, a chimney made from this formula will almost melt before it will crack with the heat. The uninitiated may tell the difference of the chimneys made of these different qualities of glass by ringing them; the vibration from the lead glass chimney has a sweet, bell-like sound, whilst the lime glass has a short, harsh sound. The difference of the cost of manufacture is only, in material, about 8d. per dozen. Another point is in annealing; chimneys as a general rule are not annealed; under a powerful microscope the difference can be seen in the glass; the particles in the annealed glass lie close and compact, while the unannealed seem ready to diverge.

Glass Chimneys, Why they Break.—The shattering of gas chimneys is caused by sudden and excessive change of temperature. If, on extinguishing the light, the chimneys are allowed to cool slowly, the spontaneous shattering complained of will not occur. A slit made by a diamond along the whole length of the chimney will often save the glass from such rupture. If the glasses were, on being taken down, embedded, while still hot, in hot ashes or other such material, and thus left to cool slowly, less breakage would occur.

Hydrogen Lamp.

—The following produces a flame with good heat, but not good light. G is a glass or earthenware vessel, with air-tight brass top, in which is screwed the valve V; and T the tube which contains the piece of spongy platina

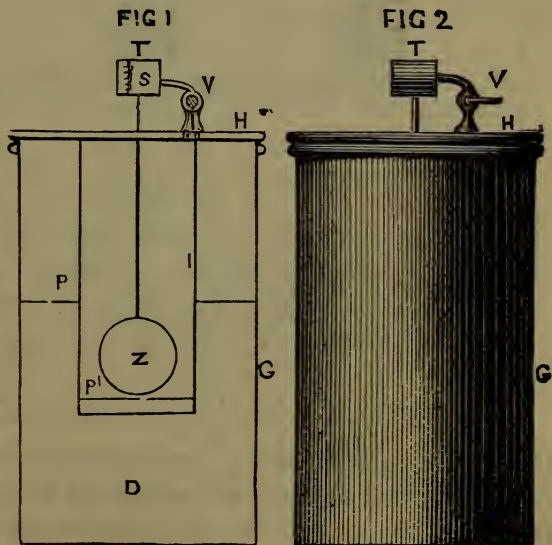

S ; Z is a ball of zinc, suspended in the inner vessel I ; H is a hole to permit the air to pass to and fro ; and D, dilute sulphuric acid ; p and p' show the relative positions of the same in the two vessels G and I, when the valve is closed. The dilute acid acting on the zinc gives off hydrogen, which, having no way to escape, forces the liquid into the outer vessel, and so prevents any further chemical action until the valve is opened, when the pressure of the atmosphere forces the acid to attain an equal level in both vessels, and so forces the hydrogen out at the nozzle and through the tube, causing the platina to become red hot and ignite the gas.

The "A B C" Gas Meter.—This meter has attached to it an index which performs at once the double duty of giving the consumption of gas and the price thereof. In the sketch is

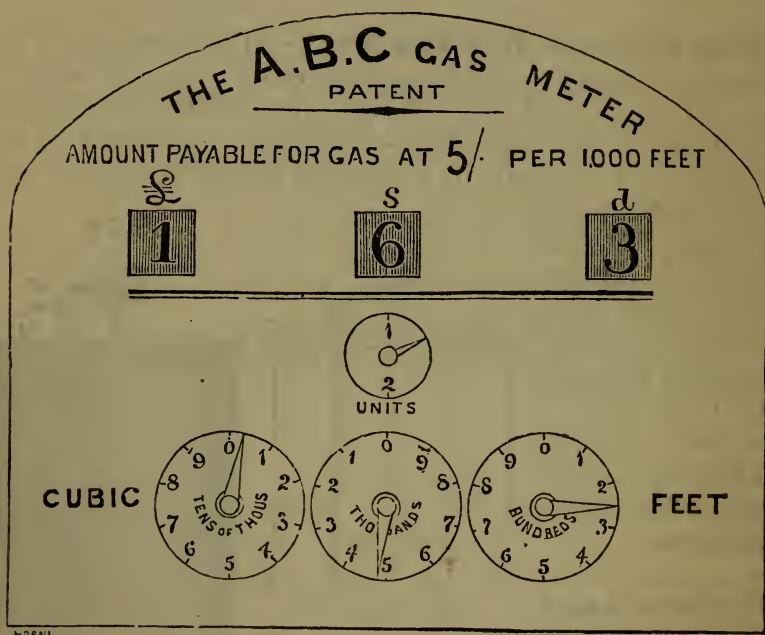

shown the patent index : 5250 ft. are supposed to have been consumed, and the money payable at the assumed price of 5s. per 1000 ft. is £1, 6s. 3d., as indicated. As $16\frac{2}{3}$ ft. from the 3d. gradually changes to 4d., and so on for every $16\frac{2}{3}$ ft. consumed, till the quantity amounts to 5400 ft., when "7" appears under the shillings' heading and "0" under the pence,

the total being £1, 7s., and so on for any larger quantity. This index should prevent all disputes as to cost. It is intended that the registration should be continuous, but that the cash index should, upon each quarterly taking of the state of the meter, be put back to zero, and a ticket of the cash, as well as the number of feet to be charged, to be left with the consumer; the one will be a check on the other. When the price of gas is changed, the index can be altered at a trifling charge, and old meters may have the cash index added for about a crown. The manufactory is at the Meter Company's Works, Johnson's Place, Lupus Street, Pimlico.

Water in Gas-Pipes.—Where the pipes have been properly laid (that is, inclining every way to the meter) it is impossible for the water to remain in gas-pipes. But it is possible that the water may have condensed in the pipes in sufficient quantity to run back into the meter, and raise the water in it above the proper level; in that case the lights would certainly go out. The remedy is to unscrew the plug of the meter, and let the surplus water run out.

Removal of Bisulphide of Carbon from Coal Gas.—This substance imparts a very disagreeable odour to gas, and the sulphur it contains is, during combustion, changed into sulphurous acid, which is injurious to animal life, destroys vegetable colours, &c. The bisulphide is a highly volatile liquid, and its entire removal from gas has been hitherto extremely difficult, if not impossible. Mr Lewis Thomson, however, has found that it may be entirely got rid of by passing the gas, after it has left the hydraulic main, and before it enters the condenser, along with a certain quantity of steam, through a tube or retort of cast iron, heated to about 1200° Fahr. The vapour of water and the bisulphide then mutually decompose each other, sulphuretted hydrogen and carbonic acid being formed. Both these are removed in the usual way.

Royal Blue Dye for Silk.—Into a tub partly filled with cold water pour 2 pints of nitrate of iron; then take 1 pint of water and $\frac{1}{2}$ pint of muriatic acid; to this add 3 oz. of crystals of tin; when dissolved, pour it into the vessel containing the iron solution, stir well, throw in the silk, and work for some time. In another tub dissolve 8 oz. of yellow prussiate of

potash, and add to it 2 oz. (by measure) of vitriol; the silk is wrung out dry from the iron solution and put directly into the prussiate solution, in which it is worked for some time. It is then washed in cold water with 2 oz. of alum dissolved in it. If the dye is not dark enough, instead of being washed in the alum-water, the silk may be put into the iron again and through the prussiate in the same way, and worked for about the same time as before, but add a little more prussiate. Deeper shades are obtained by using more iron and tin, or by giving several dips. The silk must be perfectly freed from grease before commencing the dyeing operation. The mixture above recommended will dye 5 lbs. weight of silk.

Dyes for Woollens.—For 60 lbs. of woollen yarn take 2 lbs. of flavine, 6 lbs. of alum, 1 lb. of tin crystals. Dissolve in boiling water. Then dissolve separately 4 oz. of red prussiate of potash, and add it to the above. Then add $4\frac{1}{2}$ lbs. extract of indigo and 12 oz. oxalic acid. Dye in the usual manner. This makes a full green. For *deep scarlet* take $3\frac{1}{2}$ gallons of cochineal liquor, containing $1\frac{1}{2}$ lbs. of cochineal per gallon, 36 oz. of starch. Boil, and add $\frac{1}{2}$ pint of mixed berry and fustic liquor at 15° , 1 lb. bin-oxalate of potash, 3 oz. of crystals of tin, and 12 oz. of bichloride of tin at 100° .

For Black Silk and Wool.—Silk to be dyed black must be first washed free from grease, and then gently boiled for half an hour in a dilute solution of nitrate of iron. Take out and rinse in cold water, and then boil with logwood of half the weight of the silk itself for one hour. To dye wool black, boil it with its own weight of logwood for an hour, and then add sulphate of iron in the proportion of about one pound to every thirty of wool.

For Ostrich Feathers, &c.—For ostrich feather dyeing, first expose them to sulphur-vapour to bleach them, then dye. *Black.*—Immerse for two or three days in a bath (hot at first), of logwood eight parts and copperas or acetate of iron about one part. *Blue.*—The indigo vat. *Brown.*—Any brown dyes for silk or wool. *Crimson.*—A mordant of alum followed by a hot bath of Brazil wood and a weak one of cudbear. *Pink or Rose.*—Safflower and lemon juice. *Plum.*—Red dye followed by an alkaline bath. *Red.*—Alum mordant and a hot Brazil-

wood bath. *Yellow*.—Alum mordant turmeric bath. Other shades by mixtures.

Aniline Dyes.—The colouring-matters produced from aniline and analogous matters are all, with the exception of the Fuchsine and Perkins's violet, insoluble in water, and many attempts have been made to substitute a less costly solvent for the alcohol hitherto employed. M. Gaultier de Claubry, a French chemist, has recently taken out a patent for a method of accomplishing this. He says that a great number of substances, such as gum, mucilage, almond, and other soap, glucose, dextrine, the gelatinous portion of various feculæ, of lichens, and of fuci, render water a solvent of such colouring-matter, but that the best and most economical results are to be obtained by means of decoctions of the bark known as Panama (*Quillaiia saponaria*), or of the root of the Egyptian soap-plant (*Gypsophila strutium*). The *Saponaria officinalis*, he adds, may be employed, but is less energetic in its action than the other two. The solutions are obtained by pouring the boiling liquors upon the colouring-matter in powder, agitating, decanting, and, if the solution be not complete, repeating the process. The solutions thus obtained may be reduced to extracts by evaporation, but continued ebullition, especially if the water contain sulphate or carbonate of lime, may injure the colours. A better method, according to M. Gaultier de Claubry, is to triturate the powdered colouring-matter with the extract of *Gypsophila strutium*, and then afterwards to add water by degrees; but as the reds dissolve more readily than the blues, it is necessary afterwards to mix all the products together. The solutions obtained by means of the extracts above-named are said to work readily with gum, dextrine, and albumen, separately or combined. The advantages claimed for the process by the patentee are economy, perfect unity of tints, which will not soil linen by contact, and suppression of inconvenience caused to the dyers by the use of alcohol or wood-spirit. In connection with the latter, it should be mentioned that the attempt to substitute it for alcohol has been defeated by the workmen, who have, in many instances, refused to use it on account of its effect on their health.

To Colour Straw Black.—The quantities are intended for twenty-five hats or bonnets. The articles are kept for two

hours in a boiling decoction of 4 lbs. of logwood, 1 lb. of sumach, and of 5 oz. of fustic ; afterwards they are dipped into a solution of nitrate of iron, then well rinsed with water, and when dry, are painted over with a solution of gum or dextrine. The iron liquor, as well as the other ingredients, are kept by all dealers in dye-stuffs.

Printed Cottons, to Wash.—Infuse three gills of salt in four quarts of water ; put the cotton goods in while hot, and leave till cold, and in this way the colours are rendered permanent, and will not fade by subsequent washing.

Bleaching-Powder.—When hydrate of lime, very slightly moist, is exposed to chlorine gas, the latter is eagerly absorbed, and a compound produced which has attracted a great deal of attention ; this is the bleaching-powder of commerce, now manufactured on an immense scale, for bleaching linen and cotton goods. It is requisite in preparing this substance, to avoid with the greatest care all elevation of temperature, which may be easily done by slowly supplying the chlorine in the first instance. The product, when freshly and well prepared, is a soft, white powder, which attracts moisture from the air, and exhales an odour sensibly different from that of chlorine. It is soluble in about ten parts of water ; the unaltered hydrate being left behind, the solution is highly alkaline, and bleaches feebly. When hydrate of lime is suspended in cold water, and chlorine gas transmitted through the mixture, the lime is gradually dissolved, and the same peculiar bleaching compound produced.

Waterproofing with Paraffin.—The materials which in modern times were first employed for waterproofing were bees-wax and the various kinds of drying oil, especially linseed oil, which were rendered more siccative by boiling or some other of the processes usually employed for that purpose. About forty years ago caoutchouc was first successfully used, for rendering fabrics and other materials waterproof, by the late Mr Charles Macintosh ; and after an interval of about twenty years, gutta-percha was first imported into this country, and immediately applied for similar purposes. In 1832 paraffin was discovered by Reichenbach in the course of his admirable researches on wood and coal tars ; he, however, only succeeded in obtaining it in very small quantity, so that for a long time

it was only known as a chemical curiosity. It is to Mr James Young that we are indebted for the production of this material on an industrial scale, by his process which he patented nearly fifteen years ago.

A few years ago a patent was taken out by Dr Stenhouse for employing paraffin as a means of rendering leather waterproof, as well as the various textile and felted fabrics ; and since then additional patents have been granted for an extension of, and improvement on the previous one, which consisted chiefly in combining the paraffin with various proportions of drying oil, it having been found that paraffin alone, especially when applied to fabrics, became to a considerable extent detached from the fibre of the cloth after a short time, owing to its great tendency to crystallize. The presence, however, of even a small quantity of drying oil causes the paraffin to adhere much more firmly to the texture of the cloth, from the oil gradually becoming converted into a tenacious resin by absorption of oxygen.

In the application of paraffin for waterproofing purposes, it is first melted together with the requisite quantity of drying oil, and cast into blocks. The composition can then be applied to fabrics by rubbing them over with a block of it, either cold or gently warmed, or the mixture may be melted and laid on with a brush, the complete impregnation being effected by subsequently passing it between hot rollers. When this paraffin mixture has been applied to cloth such as that employed for blinds or tents, it renders it very repellent to water, although still pervious to air.

Cloth paraffined in this manner forms an excellent basis for such articles as capes, tarpaulins, &c., which require to be rendered quite impervious by subsequently coating them with drying oil—the paraffin in a great measure preventing the well-known injurious influence of drying oil on the fibre of the cloth. The paraffin mixture can also be very advantageously applied to the various kinds of leather. One of the most convenient ways of effecting this is to coat the skins or manufactured articles, such as boots, shoes, harness, pump-buckets, &c., with the melted composition, and then to gently heat the articles until it is entirely absorbed. When leather is impregnated with the mixture, it is not only rendered perfectly waterproof, but also stronger and more durable. The beneficial effects of

this process are peculiarly observable in the case of boots and shoes, which it renders very firm without destroying their elasticity. It therefore not only makes them exceedingly durable, but possesses an advantage over ordinary dubbing in not interfering with the polish of these articles, which, on the whole, it rather improves. The superiority of paraffin over most other materials for some kinds of waterproofing consists in its comparative cheapness, in being easily applied, and in not materially altering the colour of fabrics, which in the case of light shades and white cloth is of very considerable importance.

Waterproofing for Rick Cloths.—Plunge the fabric into a solution containing 20 per cent. of soap, and afterwards into another solution containing the same percentage of sulphate of copper; wash the fabric, and the operation is finished. An indissoluble stearate, margarate or oleate of copper, is formed in the interstices of the tissue, which thus becomes impervious to moisture. This process is particularly recommended for rick cloths, awnings, &c.

Waterproofing Cotton Fabrics.—If for black work, mix enough lampblack and boiled oil to cover the whole surface; if yellow, use yellow ochre; add about $\frac{1}{2}$ lb. of driers for each gallon of oil. Give the cloth two or three coats of the above; and if, after the last coat is dry, it should remain sticky, give it a coat of the following mixture:—Boil 2 lbs. of shellac in 4 quarts of water, and add a little ammonia; when cold, add lampblack or yellow ochre as required.

Textile Fabrics, to Render Fireproof.—A very excellent method of rendering textile fabrics fireproof without injuring their colour, whatever it may be, consists in dipping them in a solution containing 35 per cent. gum, 35 per cent. starch, and 30 per cent. of the compound which is obtained by dissolving superphosphate of lime, decomposing the salt by excess of ammonia, filtering, purifying with animal charcoal, concentrating by evaporation, decomposing with 5 per cent. silex, evaporating to a crystalline mass, and then drying and pulverizing.

Electrotyping.—Wash article or mould over with a solution of acetate of copper, or nitrate of silver in alcohol, and then, without allowing it to dry, expose to the action of sulphuretted hydrogen gas. A sulphuret is formed which is an excellent

conductor of electricity ; and, when dry, may be put into the copper bath. Minute animals and delicate objects may be readily coated in this way.

To prepare the gold solution, make a saturated solution of cyanide of potassium as before, and pour off this solution upon the contents of a 15-grain bottle of chloride of gold until the latter is quite dissolved ; then dilute with water in the same ratio as in the silver electrolyte—that is, one part of the solution of chloride of gold in cyanide of potassium, with three parts of water. This solution filtered forms the gold electrolyte.

Mounting the battery for plating or gilding is the next operation. If the article or articles to be plated or gilt are small, a single element will, in all probability, be sufficient to produce the requisite amount of electric current. Place the zinc in the middle of the tumbler, then insert the earthenware cell in the zinc, and holding it down with the left hand, pour into the tumbler dilute sulphuric acid until it reaches to the upper rim of the cell. The cell itself is next filled with concentrated nitric acid. The plate or strip of platinum is finally inserted in the nitric acid. The zincs are generally amalgamated when you buy them ; if this operation has been omitted, you can do it yourself by rubbing over the moistened surfaces a cloth dipped in nitrate of mercury. Place one connecting-wire in the zinc binding-screw, and the other in the platinum binding-screw. The zinc wire is the negative pole, and is frequently called the “zincoid ;” whilst the platinum wire is the positive pole, and is denominated the “platinoid.” At the end of the negative wire the object to receive the deposit is placed by suspension on a hook, or otherwise, in metallic contact, and then immersed in the electrolyte. On the end of the positive wire either the piece of silver or of gold is fixed ; if the electrolyte be silver, the silver plate is attracted, and the gold plate in the other case. The silver and the gold coin can be beaten out into thin plates for the purpose, and then soldered to their respective wires, or attached by drilling holes and then suspending each on a hook. The objects to be gilt or plated must be *thoroughly* cleaned of all impurities, by means of a brush and rouge (sesqui-oxide of iron) ; and they must then be dipped in a solution of salts of tartar to remove grease, and finally washed in water. So prepared, they are suspended on the negative hook and immersed in the electrolyte. The plate on the

positive hook is likewise immersed in the *same* solution, and brought near to the object, *but on no account in contact* with it. The electric current now circulates, because the circuit is complete, passing along the positive wire to the plate at its end, where it comes in contact with the metallic solution between it and the object connected with the negative pole. This solution, consisting of water and a metallic salt, is decomposed by the circulating current in the following manner :—The water is decomposed into its elements oxygen and hydrogen, which, being separated, rush in opposite directions, the hydrogen towards the object, whilst the oxygen affects the positive pole or plate; and the metallic salt, infinitesimally divided by solution, is also broken up or decomposed into its elements; thus the chloride of silver is separated into silver and chlorine, the latter affecting the positive pole, whilst the silver is deposited on the negative pole. Take out the object from time to time and examine it. If the coating is purely white (if silver), or purely yellow (if gold), the operation is going on right, and may continue until the requisite amount of deposition has been obtained. By this means the metallic film thus deposited may be made of any thickness whatever. Sometimes, however, this metallic film is not pure of its kind; on the contrary, it is oftentimes granular or crystalline, and at others quite black. To prevent these irregularities is the electrotyper's chief care, and much experience and patient study are required before the best conditions can be obtained at once. Changing the distance between the two poles, moving the positive pole about, increasing or diminishing the thickness of the positive wire, warming the electrolyte, diminishing or increasing the number of elements in the circuit; these and other operations are at times necessary; when to perform them experience alone can teach. As soon as the object has received the required thickness of deposit, it is taken out of the electrolyte, washed, dried, and burnished on those parts which are to appear brilliant, whilst the remaining parts remain dead and frosted. Burnishing tools are sold for such purposes; but, in case of need, a dog's long tooth may be used. Rouge is used for polishing the object, rubbed on with a tooth-brush or wash leather.

The operation of plating or gilding over, the next care is for the apparatus. The dilute sulphuric acid, once used, is thrown away; but the nitric acid is poured back into the stock-bottle,

for future use. The latter has, however, undergone decomposition during the operation, and has become diluted with water formed by the elements liberated during the circulation of the electric current through the sulphuric acid and nitric acid; and in consequence of this gradual dilution the nitric acid becomes in course of time too much impoverished for use, and must be replaced with concentrated acid. Place the porous earthenware cell in a dish of water when it is emptied, as also the zincs for an hour or two; then remove them to drain dry.

To Electro-Gild without a Battery.—Take $\frac{1}{2}$ oz. of nitric and $\frac{1}{2}$ oz. muriatic acid; dissolve in these 1 dwt. of gold, gently evaporate until it crystallizes, then add 2 oz. of cyanide of potassium dissolved in 15 oz. of water. The article to be gilded is to be simply put in the solution, and a piece of *clean* zinc placed on it, and moved from one spot to another until it is sufficiently covered with gold.

Gilding on Steel.—In any quantity of nitro muriatic acid (*aqua regia*) dissolve gold or platina, until, on the application of heat, no effervescence ensues. Evaporate the solution thus formed to dryness by means of a gentle heat; then dissolve the dry mass thus formed in the least possible amount of water. Take the instrument known by chemists as a separating funnel, which may contain a liquid ounce; a quarter fill it with the liquid, and the other three parts fill with the best sulphuric ether. The two liquids should not mix. Then holding the tube in a horizontal position, turn it round with the finger and thumb. When the ether has become impregnated with the gold or platina, which may be known by its change of colour, replace it in a perpendicular position, and having stopped up the orifice with a cork, let it stand for twenty-four hours. At the end of this time the liquid will be divided into two parts, the darkest coloured being below. Take out the cork and let the dark liquid flow off, and stop the tube immediately with the cork. What remains in the tube is the gilding liquid. *The article to be gilded* must be perfectly free from rust or grease, and have received the highest possible polish. The process of gilding is as follows:—A vessel of glass or unglazed ware having been procured, it should be filled nearly to the top with the gilding liquid. The article should be dipped in

this for a moment, and then be plunged into clear water and well rinsed. After having been thoroughly dried with blotting-paper, it should be placed in a temperature of 150° Fahr. until it is heated throughout, and then polished with rouge and wash-leather ; or, better still, be burnished. Take care that the muriate of gold is quite free from excess of acid, and be careful to follow exactly the above directions in every particular, as only by doing so can perfect success be ensured.

Electro-Gilding for Copper Chains, &c.—Take a solution of nitro-muriate of gold (gold dissolved in a mixture of aquafortis and muriatic acid), and add to a gill of it a pint of ether or alcohol, then immerse your copper chain in it for about fifteen minutes, when it will be coated with a film of gold. The copper must be perfectly clean, and free from oxide, grease, or dirt, or it will not take on the gold.

Gilding on Glass.—Glass can be gilded in two ways, by means of fire, and by an adhesive varnish. It is gilded by fire, by tempering powdered gold with borax and gum-water. The mixture is applied to the surface of the glass with a soft pencil brush ; when dry, the article is put into a stove heated to the temperature of an annealing oven ; the gum burns off, and the borax cements the gold firmly to the article by vitrification ; after this process, the gold on the article is burnished. Gilding is also effected by an adhesive drying varnish, which is prepared by dissolving gum anime in drying linseed oil. This mixture is diluted with some oil of turpentine, and applied as thin as possible to the parts that are to be gilded. When dry, the article is to be placed in a stove or near a fireplace, till it is warm enough to almost burn the fingers when handled, at which temperature the varnish is glutinous, and a piece of gold leaf applied will instantly adhere. When nearly cold, it is burnished ; but care must be taken to intervene a piece of very thin India paper between the gold and the burnisher. Gold size is also used as an adhesive substance. The requisite burnishing-tools can be bought at any oil and colour shop.

Below we give four methods of performing this operation :—

1. Take 2 oz. isinglass, and dissolve in just sufficient water to cover it ; when dissolved, add 1 quart rectified spirits of wine and 1 quart water. This size must be kept in a bottle well corked. *Thoroughly clean and polish the glass, and lay it on a perfectly*

level table. With a brush dipped in the size flood the glass over, and then with a tip carefully lay on the gold leaf, which will instantly adhere to it. Then place the glass on its edge to dry, and leave it for twenty-four hours. On a piece of paper draw the required pattern, and with a pricker pierce holes along the outline. Then lay this on the gold surface, and dust some powdered whiting over it, so that it may penetrate the holes, and leave the pattern on the gold underneath. Carefully remove the paper, and fill in the outlines of the design with gold size, mixed with orange chrome, and thinned with boiled oil and turpentine. When quite dry, remove the surplus gold with a piece of cotton wool dipped in water, and back the glass with the ground colour.

2. First sketch on paper the exact size and shape of the figures or letters required ; then prick holes (in the outlines) through the paper with a pin ; take the paper and cover the glass on the front side with it ; now dust the paper over with whiting, so that it goes through the holes in the paper on to the glass ; remove the paper, and coat the back of the glass with gum size, and before the gum is dry take gold leaf and place it on the gum size, so that the leaf covers the dust-marks on the glass. Do not be particular about the shape of the gold leaf then ; only see that the letters are covered. When dry, paint the exact shape of the letters on the back of the gold leaf with gold size, to which has been added some chrome yellow. When perfectly dry, take a little cotton wool and water and wash off all the superfluous gold leaf. You can then shade or back the letters with any colour.

3. Make a mixture of powdered gold, borax, and gum arabic in water, and brush the device upon the glass, earthenware, or porcelain with a hair pencil dipped in the above mixture ; then expose the article to heat in an oven or furnace, by which means the gum is consumed and the borax vitrified, cementing the gold to the glass or earthenware, after which it may be burnished.

4. Breathe on the glass, apply the gold leaf, then hold a hot iron at the back a small distance off till all the moisture is dried out ; it will then assume a bright appearance. Then immediately paint on the back of it, or it will get dim. By this process no size, or anything of the kind, is needed, but only a little dexterity.

Silvering Globes, Tent Mirrors, &c.—1. The mirror to be silvered is suspended, face downwards, in a silver bath prepared thus :—A large flat shallow vessel of glass or porcelain is provided to contain the solution. One hundred and fifty grains of nitrate of silver are dissolved in 6 oz. of distilled water, and to this is added pure liquid ammonia, drop by drop, until the precipitate is re-dissolved. $2\frac{1}{4}$ oz. of caustic potash are dissolved in 50 oz. of rain-water, and 15 oz. of this solution are added to the ammoniacal solution, when a brown-black precipitate is thrown down. Ammonia is again added, drop by drop, until this precipitate is just re-dissolved ; and 29 oz. of distilled water are then added to the whole. To this mixture is again added, drop by drop, stirring with a glass rod, a strong solution of nitrate of silver, until a precipitate which does not re-dissolve is formed. Previous to immersing the mirror, one part by weight of powdered milk-sugar to ten parts by measure of distilled water must be prepared in a separate vessel, and filtered until a clear solution is obtained. Then, to ten parts by measure of the silvering solution must be added one part by measure of the milk-sugar solution, and, finally, 50 oz. of the compound solution will be sufficient to silver a speculum 9 inches in diameter. The glass surface should be made chemically clean by using whiting-cream, free from grit, and rubbing it off, when dry, with the purest cotton ; it should then be wetted with dilute nitric acid, and afterwards washed with distilled water. To suspend the mirror, a circular block of wood is firmly cemented to its back with marine glue or pitch, and three pins inserted at equal distances, to which the strings may be fastened. On lowering into the bath, care must be taken that no air-bubbles intervene, that the speculum be not deeper in the liquid than half its thickness, and that two inches at least intervene between the mirror and the bottom of the vessel. It should remain in the bath for four hours, by which time the process will be completed ; it is then removed, washed with distilled water, and placed to dry. It is now ready for polishing. Rub the surface gently, first with a clean pad of fine cotton wool, and afterwards with a similar pad covered with cotton velvet, which has been charged with fine rouge.

2. The following is one of the cheapest and most durable methods :—Make an alloy of 10 oz. bismuth, 6 oz. lead, and

4 oz. tin ; put a portion of this alloy into the globe, and expose it to a gentle heat until it melts ; then turn the globe slowly round, so that an equal coating of the alloy is spread over the whole surface. This, when cold, will harden, and cannot be surpassed for durability.

3. Take 1 oz. of clean lead, 1 oz. of fine tin, and melt them together in a clean iron ladle ; then immediately add 1 oz. of bismuth, skim off the dross, take the ladle from the fire, and before the mixture sets add 10 oz. of quicksilver, stirring all well together.

4. The "*Humid Process*," as it is called, is as follows :— Four solutions are to be prepared—No. 1. Ten grammes of nitrate of silver in 100 grammes of distilled water. No. 2. An aqueous solution of ammonia standing at 13° of Cartier's aerometer. No. 3. Twenty grammes of pure caustic soda in 500 grammes of distilled water. No. 4. Into a solution of common white sugar there is to be poured one cubic centimetre of nitric acid at 36° ; it is then to be boiled for twenty minutes to produce interversion. There is then to be added 50 cubic centimetres of alcohol at 36°, and as much distilled water as will bring the whole to 500 cubic centimetres. Into a flask holding about 200 cubic centimetres there is to be poured—

12	cubic centimetres	of solution	No. 1.
8	"	"	No. 2.
20	"	"	No. 3.
50	"	"	of distilled water.

The liquid should remain perfectly limpid. This solution is allowed to repose for twenty-four hours. Now as to its application. The surface of the glass to be silvered must be scrupulously cleaned, and then passed over with a ball of cotton wet with nitric acid at 36°, and finally washed with distilled water, and drained from this and placed upon supports at the surface of a bath composed of the silvering fluid as above, to which has been added one-tenth or one-twelfth of its bulk of solution (No. 4). Under the influence of diffused daylight, the surface to be silvered (immersed in the bath) is seen to become first yellow, then brown, and in two to five minutes the silver will be found to be uniformly spread over the glass ; in ten or fifteen minutes the coat will be found to be thick enough. The glass is then to be washed in common and afterwards in distilled

water, and left to dry in free air. When dry, the surface presents a perfect metallic polish, covered, as it were, by a thin veil. It is then polished with chamois leather and the finest rouge; a metallic surface of the utmost brilliancy will be the result. The gramme = 15.434 grains. Cubic centimetre = .165 of a cubic inch.

Silvering Brass.—Brass and copper are the only metals that can be silvered without a battery. The process of silvering brass is thus described:—In 8 oz. of water dissolve 2 oz. of cyanide of potassium, and in the same quantity of water 1 dr. of nitrate of silver. Into the vessel containing the silver throw about half a spoonful of common salt; stir this well with a glass rod until the silver is precipitated. Mix a little salt and water, and add a few drops to the solution after it has had time to settle. If any cloudiness follow, more salt must be added. When the addition of salt water has ceased to have any effect, carefully pour off the water and preserve the deposit. Wash this deposit two or three times in boiling water, and then carefully dry. Place this powder in a vessel, and pour on it about a pint of water, and add the cyanide solution about $\frac{1}{2}$ oz. at a time until the precipitate is dissolved, then add enough water to make about a quart. While adding the cyanide solution stir well. If when dipping the article into this solution the silver deposits too quickly, more water must be added; if it coats very slowly, the solution must be strengthened with more precipitate. This must be also done whenever the solution becomes weak. The solution when in use should be kept at a temperature of from 60° to 70° of heat. After polishing and burnishing, the article silvered should be as brilliant and durable as can be wished.

Silvering-Powder for Coating Copper.—Take 60 grains of nitrate of silver; 60 grains of common salt, and 7 drs. of cream of tartar. Mix them, and moisten with water, and then apply.

Silvering Mirrors.—The process of employing a layer of tin-foil and mercury, commonly but falsely called “silvering,” is as follows:—A sheet of tin-foil corresponding to the size of the plate of glass is evenly spread on a perfectly smooth and solid marble table, and every wrinkle on its surface is carefully rubbed down with a brush. A portion of mercury is then

poured on, and rubbed over the foil with a clean piece of very soft woollen stuff, or a hare's foot, after which two rules are applied to the edges and mercury poured on to the depth of a crown piece, when any oxide on the surface is carefully removed, and the sheet of glass, made perfectly clean and dry, is slid along over the surface of the liquid metal, so that no air, dirt, or oxide can possibly either remain or get between them. When the glass has arrived at its proper position, gentle pressure is applied, and the table sloped a little to carry off the waste mercury, after which it is covered with flannel and loaded with heavy weights. In twenty-four hours it is removed to a wooden table, and further slanted; and this position is progressively increased during a month, until it becomes perpendicular.

Picture-Frame Stain.—To stain a picture frame black, procure some logwood chips, and boil them; give your frame a coat of the boiling liquid. You will find this generally raise a roughness on the wood; let it dry, and then use sand-paper; then give it another coat of the warm liquid, and before it dries give it a coat of iron liquor. If you want a good job, put a little ivory-black in your polish.

To Gild Picture Frames.—Provide yourself with the following articles: a cushion, made by covering a board of about 8 in. square with a double thickness of flannel, and over that a piece of buff leather, and fastening it tight round the edges; a palette knife, for cutting the leaves into the requisite sizes; a tip, a fitch pencil, a ball of cotton, and a large camel's-hair brush. The frame intended to be gilt should first be well sized, and then done over with seven or eight coats of size and whitening, so as to cover it with a body of considerable thickness. Having got a sufficient quantity of whitening on, it must be carefully cleaned off, taking care to free all the cavities and hollows; it is then to receive a coat of size, and be left till nearly dry. The work being thus prepared, place it a little declining from you, and having ready a cup of clean water, and some hair pencils, moisten a part of the work, and apply the gold leaf by the tip to the part. The gold will immediately adhere, and is then to be pressed down by the ball of cotton. Proceed thus until the whole is finished, leave by for twenty-four hours, and then burnish the prominent parts with an agate burnisher.

Gilding and Plating.—The following instructions are condensed from an article by Professor Towler, a capable and experienced instructor :—

The first thing required is a galvanic battery. There is a great variety of galvanic batteries to be had, but we prefer a Grove's battery. A single element consists of a cylinder of zinc, a thin plate of platinum, a tumbler, a cell of porous or unglazed earthenware, two binding-screws, two solutions (dilute sulphuric acid and concentrated nitric acid), two connecting-wires, and a plate of silver and one of gold (a two-shilling piece for one, and a gold dollar for the other). Two of these elements will be sufficient for almost all ordinary operations of gilding, and sometimes only one is required. The zincs, plates of platinum, porous cells, binding-screws, tumblers, and connecting-wires, can be bought already prepared for electrolyte operations and ready for mounting. Mix one fluid ounce of commercial sulphuric acid with ten fluid ounces of water for one solution. The strongest aquafortis or commercial nitric acid is suitable for the other solution.

In the second place a silver and a gold solution have to be prepared, and kept on hand ready for use. Each of these solutions is denominated an electrolyte, and the art of decomposing such a solution by means of an electric current is known by the name of electrolysis. *To prepare the silver solution,* take a solution of nitrate of silver, and add to it a solution of common salt as long as any white precipitate is produced. Perform this operation in a darkened room, because the white precipitate (chloride of silver) is very sensitive to light, thereby changing into a violet-coloured powder, which is insoluble in the fluid into which it is subsequently mixed. As soon as the precipitate has completely subsided, pour off the supernatant fluid, and add to it a few drops of the salt solution; if no milkiness is produced, the silver has all been removed as chloride, and consequently the fluid may be thrown away as useless. Mix the white chloride with rain-water, and stir the mixture with a glass rod, and allow the precipitate to settle again; this is called washing the precipitate. When the precipitate has subsided, the fluid part is poured off, and the residue is again washed. This operation is repeated several times, and the chloride, finally separated by decantation from the wash-water, is ready for the next treatment. Make a saturated solution of cyanide

of potassium in rain-water—that is, add lumps of the cyanide as long as it is dissolved, and finally a small part is left undissolved. The water is then saturated with the salt. Pour this saturated solution of the cyanide upon the chloride of silver, and keep pouring and stirring until the chloride is entirely dissolved. Filter the solution, and dilute as follows:—Silver electrolyte: saturated solution of the chloride of silver in cyanide of potassium, 4 oz.; rain-water, 12 oz. The solution is then ready for use.

Picture-Frame Making.—The following is a simple and easy plan for making picture frames. Take a common deal board 9 in. wide and 1 in. thick; cut it into four slips, run a rabbit plane on one edge, for the glass, picture, and back to fit into. Cut it into lengths, according to the size of the pictures; countersink the sides into the top and bottom; one screw in each angle, put in from the back, will keep them firmly together. A cord round the projections at the top will serve to hang the picture.

Deal may be stained a dark oak-colour, by giving it two or three coats of a solution of 1 oz. bichromate of potass, and 2 oz. of bluestone, in 12 oz. of water; after which, apply plain drying oil, and finish with copal varnish. The oil deepens the colour and brings out the natural graining.

For clamping picture frames, proceed thus:—Cut four pieces as No. 1; drill a hole through as shown; cut a small channel as

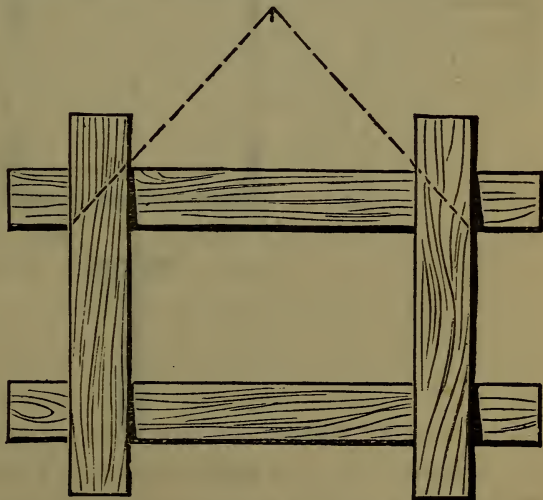

shown; cut two pieces as No. 2 and 3 six inches long; drill No. 2 half-way through for end of screw, the same as the ordinary clamp. No. 3 is to be tapped to fit screw. In addition two small holes same size as through angles and as shown.

Get a length of catgut about $\frac{1}{8}$ in. thick. Put it through the angles and No. 3. Before glueing, see that the catgut is about the size of the frame. Then glue and put the angle-pieces on, and screw up as shown in No. 4. They can all be made of beech 1 in. thick. This plan is expensive, and rather slow. Prints *must* have a glass over them, and so be secured from the entrance of dust, flies, and damp. The glass of each frame is laid in with a composition like plaster, blackened to suit the dark frames; and, besides this, glass is pasted all round inside to the frame with a narrow strip of paper. Within the glass is the gilt moulding, which thus serves to keep the print and the glass a quarter of an inch apart. The print, being attached by its edges, or its corners, to the backboard, is put in over the gilt moulding, and the whole of the back securely pasted over with strong paper. The only prints that turn yellow are those pasted on to canvas stretchers. This is probably caused by the paste. The paste to be used for all prints and drawings should be

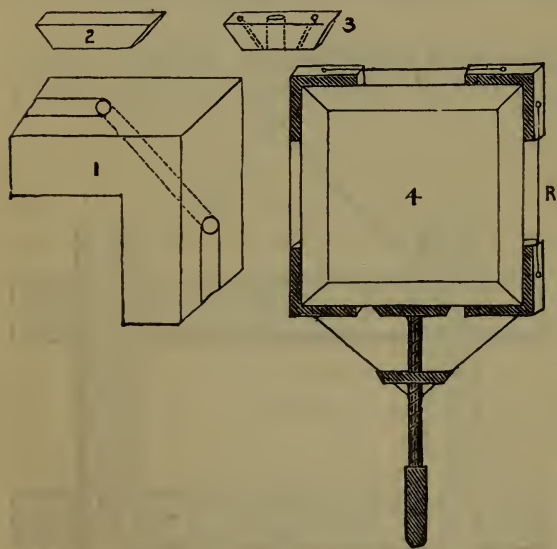

shoemakers' paste, which has alum in it; and besides, not breeding insects, will attach paper to wood thoroughly. The putty, paste, &c., used must be quite dried after each part of the process of framing, before proceeding to paste up the back. The print itself must be also thoroughly dried. The best composition for picture-frame cornices

is composed of size and whiting. The best size is made by well-soaking buffalo skin, and then boiling it to the consistency of jelly. For touching up old frames the common size will do.

Compo Ornaments for Picture Frames.—In a quart of water boil $3\frac{1}{2}$ lbs. of the best glue, and in 3 gills of raw

linseed oil melt $1\frac{1}{2}$ lbs. of white resin. When these ingredients are well boiled, let them simmer together in a large vessel for about half an hour, stirring the mixture, and taking care it does not boil over. When this is done, pour out the mixture into a large quantity of finely-ground whiting, and roll it to the consistency of dough, and it is then ready for use.

Composition Ornaments.—Dissolve $\frac{1}{2}$ lb. of glue in 2 quarts of water. Boil together 1 lb. of resin, $\frac{1}{2}$ gill of Venice turpentine, and 1 gill of linseed oil. Put these two mixtures into one kettle, and boil together, stirring well until all the water has evaporated; then add finely-powdered whiting until the mass has attained the consistency of putty. This composition becomes hard when cold, but when warm may be readily moulded to any pattern required, and is more durable than wood.

Gilding Organ Pipes.—After being perfectly cleaned, the pipes should be painted over with flat lead colour finely ground, mixed with plenty of patent driers, and a little boiled linseed oil. (Two coats may be given, the first to be thoroughly dry before the second is applied.) After the second coat is thoroughly dry, the surface must be covered with gold size (which can be purchased ready prepared at the colour-shops, or made as directed (page 286). When the gold size is nearly dry, or in a “tackey” or slightly sticky state, the gold leaf must be applied carefully, and pressed down evenly with a soft ball of cotton wool. After a short time all the loose particles of gold may be removed by carefully rubbing with the ball of cotton wool. The coloured patterns are produced by the following method:—Sheets of glazed paper, having the patterns it is desired to colour cut out, are placed over the gilded parts, and oil colour dabbed carefully through with a soft brush. The colours should be mixed with patent driers, turps, and very little oil, to make them flat. If two or more colours are desired in the pattern, papers for each different colour in the pattern must be cut out.

Imitation Silvering or Gilding.—A small quantity of melted tin is poured into a box, which is then closed and violently shaken, so as to reduce the tin to a fine powder. This powder is mixed with a small quantity of size or thin glue. The article

to be gilded or silvered is then coated and allowed to nearly dry. Burnish with an agate burnisher, and, if required to imitate silver, coat with seed lac varnish ; but if to imitate gold, colour the varnish with a mixture of gamboge and anatto. The chief difficulty is to obtain the proper proportion of size to tin ; for if too much size is used, the burnisher will produce no effect ; and if too little, the tin will crumble off.

Mosaic Gold.—To make what is termed “ mosaic gold,” heat together in a crucible or iron ladle a mixture of six parts of tin, three of mercury, three of sal-ammoniac, and about the same of flowers of sulphur. Most of these will be sublimed by the heat, and a solid shining substance of the appearance of gold will remain.

Bronze and Bronzing.—Bronzing is of two kinds : the purpose of the one is to cover objects of all kinds with a coating which shall give them the appearance of bronze, while the other kind of bronzing modifies the surface of various metals, and protects them from the action of the air. The operation varies according to the nature of the body to be bronzed, as explained below.

Bronzing Plaster Casts.—To cover plaster casts, statuettes, &c., with a very durable green coating, which will protect them against atmospheric agencies, and give them a colour resembling antique bronzes, employ ferro-cupreous soap, which is prepared thus :—A soap is made with linseed oil and caustic soda ; a concentrated solution of sea-salt is added, and the whole evaporated until the soap begins to float in grains on the surface ; it is then filtered through a metal strainer, and the grains of soap thus collected are dissolved in boiling water, and the solution again filtered to remove impurities. On the other hand, dissolve in hot water four parts of sulphate of copper and one part of sulphate of iron ; then pour the liquid into the solution of soap slowly, and continue to stir the mixture until no more precipitate is formed. This precipitate is the ferro-cupreous soap named above—that is to say, a mixture of brownish-red ferruginous soap, and a very beautiful green cupreous soap. These two colours, when mixed, yield a brownish-green tint, very similar to the *verd antique*. To purify this soap, collect it upon a filter, and boil it for a few minutes in the

solution of iron and copper; then wash it in pure boiling water, next in cold water, then drain and dry it as much as possible.

To bronze a plaster cast, mix in a *bain marie* 30 oz. of refined boiled linseed oil, 16 oz. of ferro-cupreous soap (made as directed above), and 10 oz. of white wax; when the mixture is melted, apply it with a brush upon the plaster (heated in an oven to a temperature of 180° to 200°). Repeat the application where needed, and leave the cast in the stove for a few minutes. The mixture thoroughly penetrates the plaster, filling its pores, without in any respect injuring the delicacy of detail. When small pieces are to be prepared, they may be immersed in the melted mixture, drained, and placed before the fire until the mixture has completely sunk into the plaster. Finish by rubbing the surface with a tuft of cotton. Plaster figures may be *silvered* by rubbing them with an amalgam formed of equal parts of mercury, bismuth, and tin, and afterwards covering them with a coat of pale varnish. A *metallic lead-grey colour* is imparted to the figures by brushing them over with fine plumbago or graphite.

Another method.—Go over the figure with isinglass size until every part is covered, and the plaster has ceased to absorb. Then go over the whole with a stiff brush, taking care that none of the size lodges in the more delicate parts of the figure. When it is dry, with a brush containing just enough thin oil gold size to damp it, go over the figure, and set it aside to dry for about forty-eight hours. Touch then the whole figure with bronze powder, and let it stand for twenty-four hours; then with a soft brush remove all the loose powder, particularly from the more prominent parts.

Bronze Powder.—Dissolve copper filings in aquafortis; when the copper has impregnated the acid, pour off the solution, and put into it some pieces of iron, or iron filings; the effect of this will be to sink the powder to the bottom of the acid; pour off the liquor, and wash the powder in successive quantities of fresh water. When the powder is dry, it is to be rubbed on the figure with a soft cloth, or piece of leather; but observe that, previously to the application of the bronze powder, a dark blackish sort of green is to be laid on the figure; and if you wish the powder to adhere stronger, mix it with gum-water. Lay it like paint, with a camel's-hair brush, or pre-

viously trace the parts to be bronzed with gold size, and when nearly dry rub the powder over it.

Gold Size.—Take 1 lb. of linseed oil, add 4 oz. gum animi gradually, stirring well over a clear fire until the whole is dissolved. Then boil until a drop, when taken out and cooled, becomes as thick as tar; strain through a coarse cloth, and put aside ready for use. When used, add as much vermilion as will make it opaque, and thin with oil and turpentine.

Gold Powder.—Grind leaf-gold with virgin honey until the leaves are thoroughly broken up and divided; then stir the whole in a basin of water until the honey is dissolved. Leave the basin then undisturbed for a short time; and when the gold has subsided, pour off the water, adding several fresh quantities until all the honey is washed away, after which filter and dry for use.

Copper Bronze.—Copper articles are bronzed by the following process:—Dissolve in vinegar two parts of sal-ammoniac and four parts of verdigris. Boil, skim, and dilute with water until a white precipitate ceases to fall. Thoroughly cleanse the articles from grease or other impurities, and set them in a pan. Boil the above solution, and pour it over the articles, and then boil them in it until a reddish-brown colour is produced. When this is the case, which must be ascertained by frequent inspection, the articles must be at once removed, and then repeatedly washed and dried. The solution must not be too strong, as should it be so, the bronze will come off with friction, or turn green when exposed to the atmosphere. The best bronze for copper is that used by urn-makers and medal-lists. It is essential that the preparation of iron should be of a good quality and free from grit, and that it shall be mixed in boiled clear water until it is of the thickness of cream. The copper articles being ready, the surface must be coated with the red cream, and then held over a very hot fire which is free from sulphur, and turned round and round so that all parts may come in contact as soon as possible. To perform this operation well great practice is required. The articles are subsequently burnished.

Brown Bronze Dip.—Iron scales, 1 lb.; arsenic, 1 oz.; muriatic acid, 1 lb.; zinc (solid), 1 oz. Let the zinc be kept in only while it is in use.

Green Bronze Dip.—Wine vinegar, 2 quarts ; verditer green, 2 oz. ; sal ammoniac, 1 oz. ; salt, 2 oz. ; alum, $\frac{1}{2}$ oz. ; French berries, 8 oz. ; boil the ingredients together.

Olive Bronze Dip for Brass.—Nitric acid, 1 oz. ; muriatic acid, 2 oz. ; add titanium or palladium ; when the metal is dissolved, add 2 gallons of pure soft water to each pint of the solution.

To Bronze Gun Barrels.—Dilute nitric acid with water and rub the gun barrels with it ; lay them by for a few days, then rub them with oil and polish them with beeswax.

Green Bronze.—Bronzes steeped for several days in a strong solution of common salt, if washed in water and allowed to dry slowly, become permanently green ; or a strong solution of sugar with a little oxalic acid will produce the green colour. A dilute solution of ammonia allowed to dry on the surface produces an evanescent green.

Black Bronze for Brass.—Put $3\frac{1}{2}$ lbs. of scales that fall from the red iron hammered at the blacksmith's anvil into 7 lbs. spirits of salt, and both into an earthenware pan, in which let them stand for about five hours, covered close, to keep in the fumes ; stir it three or four times ; strain off into a stone bottle, into which put $1\frac{1}{2}$ lbs. of white powdered arsenic ; shake well, let it stand for a day or two, and the mixture is ready for use. Before using cleanse the brass from grease either with emery-cloth or a brush, with sand and plenty of water. Next dip the brass in the bronze until it is black ; then wash it in clean water, then in boiling water—for thus heat is given to dry the work and preserve the bronze. A soft black-lead brush is then applied with some good lead ; then the article is to be lacquered with a very pale lacquer and heated in an oven or on a hot plate to set it hard. For green do the same work with green lacquer for brass, to be had in any colour-shop. *To make iron green*, cleanse it first from grease, then give it a coat of blacklead, next one of green lacquer ; then make the article hot in an oven or on a plate, put on another coat of lacquer, and heat finally.

Black Bronzing Iron and Steel.—The following method of colouring iron and steel to serve both as an ornamentation and

preservative from rust is the discovery of M. Thirault, and has been successfully adopted in many factories. The following mixtures are not the only ones that can be employed, but are given as examples :—

Liquid No. 1.—A mixture of bichloride of mercury and sal-ammoniac.

Liquid No. 2.—A mixture of perchloride of iron, sulphate of copper, nitric acid, alcohol and water.

Liquid No. 3.—Perchloride and protochloride of mercury, mixed with nitric acid, alcohol and water.

Liquid No. 4.—A weak solution of sulphide of potassium.

A sponge is slightly moistened with liquid No. 1, and rubbed upon the metal, previously well cleaned, and when quite dry, a second application of the liquid is made; the crust of oxide formed upon the application of the liquid is removed by a wire brush, and the metal rubbed with a clean piece of rag, and this operation is repeated after every fresh application of the several liquids. Several coats of liquid No. 2 are then applied, and also of No. 3, with a full sponge; and after drying for ten minutes, the pieces of metal are thrown into water heated nearly to the boiling-point, where they are allowed to remain five or ten minutes, according to their size. After being cleaned, they are again covered with several coatings of liquid No. 3, afterwards with a strong coating of No. 4, and again immersed in the bath of hot water. When removed from the bath, the pieces are dried and wiped several times with carded cotton, dipped in liquid No. 3, diluted each time with an increased quantity of water; then they are rubbed with a little olive oil and wiped; they are again immersed in water heated to 140° Fahr., and upon being removed from it they are rubbed briskly with a woollen rag, and, lastly, with oil. The pieces thus treated are of a beautiful glossy black, especially if they have been polished. Iron and cemented steel are well adapted to receive this black polish; cast steel is still better adapted for it, as it assumes a more uniform brilliancy. Cast iron presents more difficulties, because it does not assume the same tint all over equally.

Bronzing Wood.—First cover the wood with a uniform coating of glue, or of drying oil, and when nearly dry the bronze powder, contained in a little bag, is dusted over it. This

bronze powder is made of various materials, such as brass, tin, gold, ormolu pulverized, or of metallic copper obtained in a pulverulent form by precipitation from its saline solutions by means of iron. [The process is as follows :—They begin with preparing the proper alloy, either of copper and zinc or copper and tin, in due proportions. These alloys are cast in plates and hammered out into sheets by steam hammers. After they have been brought to the thickness of a stout sheet of paper, these sheets, with frequent intervening annealings, go through a system of rollers, from whence they go to the acid room, where diluted acid and washing with water removes the scale and stains. The cutting of the sheets into shreds is the next operation, after which the shreds of fine sheet metal are well mixed with dextrine, to avoid the dust of the next stage of manufacture. Powerful quartz crushers then soon reduce the metal to coarse powder, ready to go to the grinding and polishing mills, which consist of tempered wavy steel plates, over which steel rods travel at a great speed, grinding and polishing the bronze at the same time, and the quality or grain of the article is determined by the length of time to which it is subjected to the operation of these mills. Washing and straining the bronze powder, to get rid of accidental impurities of the dextrine, are the next steps, after which the bronze is put into bags of fine but strong cloth, and exposed to the pressure of a hydraulic press, to squeeze the water out and lessen its bulk. Drying at a low temperature and packing into pound or ounce packages makes the article ready for the market.] The surface of the objects is afterwards rubbed with a piece of moist rag, or the bronze powder may be previously mixed with the drying oil and applied with a brush.

Bronzing Paper.—When bronzing paper, use gum instead of drying oil. When dry, the paper should be burnished.

Pyrotechny.—A few of the simple and more effective fireworks are given below. The utmost care should be observed in all preparations of the kind—in filling, mixing, and exhibiting—as most of the ingredients are highly explosive, either on concussion or at a comparatively low temperature.

Coloured Fires.—The following may be burnt open :—*Red.*
—1. Nitrate of strontia 12 parts ; chlorate of potash, 3 parts ;

shellac, 1 part. The strontia to be heated until deprived of its water of crystallization, then finely powdered. The chlorate and shellac also powdered, and all mixed intimately. The rationale of this formula is that the chlorate supplies oxygen, the shellac carburetted hydrogen. The perfect combustion of these gases gives no smell. 2. Spirits of wine burnt on finely-powdered nitrate of strontia. 3. Dry nitrate of strontia, 5 oz.; finely-powdered sulphur, $1\frac{1}{2}$ oz.; chlorate of potash, 5 drs.; sulphuret of antimony, 4 drs. Powder the chlorate and sulphuret separately; mix on paper, and add the others previously powdered. For use, mix some powder in a small quantity of spirits of wine. Should the fire burn badly, add a very little powdered lampblack or charcoal. *Green or Blue.*—When copper is burned in a hydrogen flame it gives a bright green colour, but the moment a little free chlorine is introduced the colour becomes a beautiful blue.

In addition to the above, any of the simple preparations of colours given under “Rockets” and “Roman Candles” may be adapted for burning open.

Roman Candles.—The cases are made by tightly winding stout paper around a mandril or ruler, the desired size, and between each wind or roll round the ruler paste should be applied to the paper. When the case is thus made and wet, it must be tied round the bottom to close that aperture, and to form a solid bottom to work upon.

Before *filling* the case (which is the next process) introduce a little clay to the bottom, thereby forming a better and firmer bottom. Next add a little coarse powder, and cover it with paper. It is now ready to receive the composition which is thus made:—Mealed powder, $\frac{1}{2}$ lb.; saltpetre, $2\frac{1}{2}$ lb.; sulphur, $\frac{1}{3}$ lb.; glass dust, $\frac{1}{2}$ lb. This should fill about a sixth, and be covered in about two-thirds of its diameter. Then add corn powder and a ball smaller than the diameter. More composition should now be added, until the case is one-third full; then paper, powder, and ball again until it is finished, the top being composition. Paste touch-paper round the hole and add a priming of powder.

The best way of exhibiting these Roman candles is to place them in rows on a stand, some perpendicular, others declining in divers angles, that the balls may be projected to various distances, and produce a more splendid effect. The greatest declension should not exceed 45° or 50° .

Composition for the Coloured Balls.—Various forms are used, but the best is to make the composition into a paste, then roll it into shape (as directed above), and when rolled in pulverized powder (whilst moist) they are ready for use. *Blue balls or stars*:—Mealed powder, 8 oz.; saltpetre, 4 oz.; sulphur, $2\frac{1}{2}$ oz.; isinglass, 2 oz.; spirits of wine, 2 oz. *Stars or balls of fine colour*:—Mealed powder, 1 oz.; saltpetre, 1 oz.; sulphur, 1 oz.; oil of turpentine, 4 drs.; camphor, 4 drs. *Purple stars*:—Chlorate of potash, 42 parts; saltpetre, $22\frac{1}{2}$ parts; sulphur, $22\frac{1}{2}$ parts; black oxide of copper, 10 parts; Ethiop's mineral, $2\frac{1}{2}$ parts. *Green stars*:—Nitrate of barytes, $62\frac{1}{2}$ parts; sulphur, $10\frac{1}{2}$ parts; potash, $23\frac{1}{2}$ parts; orpiment, $1\frac{1}{2}$ parts; charcoal, $1\frac{1}{2}$ parts. *Yellow stars*:—Nitrate of soda, $74\frac{1}{2}$ parts; sulphur, $19\frac{1}{2}$ parts; charcoal, 6 parts. *Crimson stars*:—Chlorate of potash, 17 parts; strontian, 55 parts; charcoal, 4 parts; sulphur, 18 parts. They may be slightly moistened with spirit. *Great care must be taken, or spontaneous combustion will take place.*

Coloured Stars for Rockets.—The different fires should always be made up wet—mixed into a rather dry paste with gum-water (8 oz. of gum to a pint is sufficient), and the stars pressed into a little mould, by which means they will do with much less gum-water. The proportions for the stars have been given thus:—Mix meal powder, 2 parts; camphor, 1 part; sulphur, 1 part; coloured fire, moistened with oil of turpentine, 1 part. Work together in little round balls, and place in rocket.

Sulphur and potash should never be rubbed together by themselves, but French polish enough should be used to make a dough, which should be rolled well on a board to the thickness of a quarter of an inch; when dry, the dough should be cut into small cubes. It is better to buy the chlorate of potash all ready ground, and care must be taken in mixing, as it explodes at a low temperature with all combustible substances, and the stars should be well dried in a tin water-bath, and the red stars kept in a dry well-stopped bottle.

The various colours are made in the following proportions:—*Red*.—1. Dry nitrate of strontia, 72 parts; sulphur, 20 parts; gunpowder, 6 parts; coal-dust, 2 parts. 2. Nitrate of strontia, 16 parts; chlorate of potash, 8 parts; sulphur, 4 parts; charcoal (fine), 1 part.

Rockets.—Among the most effective of fireworks are rockets. To make them, erect a small monkey machine, two uprights 3 ft. 6 in. high, with head and pulley fixed in same. A piece of beech for monkey, 4 lbs. weight, and sliding up and down between uprights, being kept to its place by beads nailed to uprights. A ring and cord are fixed to monkey to raise it by the pulley, and a pin or other contrivance for keeping the monkey suspended when required.

The moulds required for supporting the cases while being rammed are generally cast-brass cylinders, bored to the external diameter of the case.

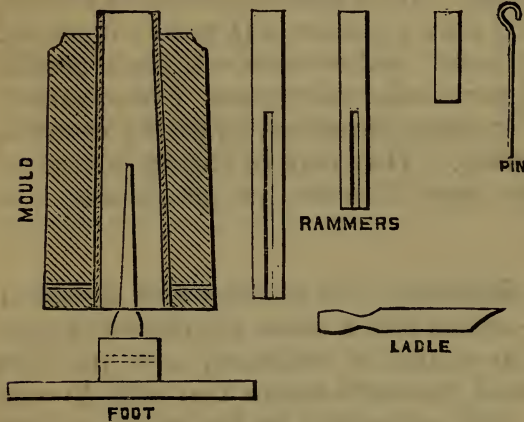

Use pieces of brass tube of the proper bore, driven into a hollow cylinder of beech to support it. The foot of the mould is a cast-brass flange $\frac{3}{8}$ in. thick, with a solid cylinder 1 in. high for the mould to fit over and nipple cast on; the brass spindle

is then screwed into the nipple and the whole turned up in a lathe; finally a $\frac{1}{4}$ -in. hole is bored through the mould 1 ft. $\frac{1}{2}$ in. above the bottom, through which a pin fastens the mould to the foot during the ramming.

The rammers are pieces of cast bar brass turned down to 1 16th in. less than the internal diameter of the case, and bored to fit over the spindle the exact size of same; the second rammer half way up spindle, and the exact size of the taper half way up; the third rammer to be short for the solid charge above the spindle. It is useless to make wooden rammers, as they would not last under the monkey for half-a-dozen cases.

The charges are introduced with ladles made of thin brass tube, with a handle driven in one end and cut obliquely at the other, and should contain sufficient composition to rise $\frac{3}{4}$ of a diameter after ramming.

The internal diameter of the case determines the length and

proportions of the spindle. It will be best to give the sizes of the cases in ounces and diameters. 1 oz. case, 4-10ths of an inch internal diameter; 2 oz. ditto, $\frac{1}{2}$ in.; 4 oz., 7-10ths; 8 oz., 9-10ths, and the thickness of the paper cases one quarter the internal diameter, making a 2 oz. case of $\frac{1}{2}$ in. internal diameter $\frac{3}{4}$ in. external ditto.

The rule for the proportions of spindle. The length is $4\frac{1}{4}$ times the internal diameter of case, thickness at bottom $\frac{1}{2}$ diameter, tapering to the top at one half the diameter at the bottom.

The sticks should be of clean yellow pine, and of such length that, when tied on the rocket charged with stars, they should balance one another $\frac{1}{2}$ an inch from the mouth of the case. The lighter and longer the sticks are the better, but must be strong enough to bear the great force of the fire against them. 2 oz. rockets 3 ft. long and $\frac{1}{4}$ in. square; 4 oz. ditto, 3 ft. 6 in. long, and $\frac{1}{2}$ in. \times $\frac{1}{4}$ in.; 8 oz., 5 ft. long, $\frac{1}{2}$ in. \times $\frac{5}{8}$ in.

Composition for Rockets.—One of the best compositions for the body of sky rockets is 8 parts nitre, 3 parts charcoal, and 2 parts sulphur. 1. For one or two-ounce rockets—1 lb. of gunpowder, 2 oz. of charcoal, and $1\frac{1}{2}$ oz. of saltpetre; powder separately and mix. 2. Two to three-ounce rockets—to 4 oz. of gunpowder add 1 oz. of charcoal, or to 9 oz. of powder add 2 oz. of saltpetre. 3. Four-ounce rockets—to 1 lb. of gunpowder add 4 oz. of saltpetre and 1 oz. of charcoal. 4. Five or six-ounce rockets—gunpowder, 2 lbs. 5 oz.; saltpetre, $\frac{1}{2}$ lb.; sulphur, 2 oz.; charcoal, 6 oz.; and iron-filings, 2 oz. 5. Seven or eight-ounce rockets—gunpowder, 17 oz.; saltpetre, 4 oz.; sulphur, 3 oz. 6. Eight to ten-ounce rockets—gunpowder, 2 lbs. 5 oz.; saltpetre, 8 oz.; sulphur, 2 oz.; charcoal, 7 oz.; iron-filings, 3 oz. 7. Ten or twelve-ounce rockets—gunpowder, 1 lb. 1 oz.; saltpetre, 4 oz.; sulphur, $3\frac{1}{2}$ oz.; charcoal, 1 oz. 8. Twelve to fourteen-ounce rockets—gunpowder, 2 lbs. 4 oz.; saltpetre, 9 oz.; sulphur, 3 oz.; charcoal, 5 oz.; iron filings, 3 oz. 9. One-pound rockets—gunpowder, 1 lb.; charcoal, 3 oz.; sulphur, 1 oz. 10. Two-pound rockets—gunpowder, 1 lb. 4 oz.; saltpetre, 2 oz.; charcoal, 3 oz.; sulphur, 1 oz.; iron-filings, 2 oz. 11. Three-pound rockets—gunpowder, 4 oz.; saltpetre, 1 lb.; sulphur, $8\frac{1}{2}$ oz.; charcoal, 2 oz. 12. For rockets of the largest size—

to 8 lbs. of saltpetre add 20 oz. of sulphur and 44 oz. of charcoal. The ingredients in each of these are to be separately powdered, and then thoroughly mixed.

Another variety of composition is made thus:—For two-ounce rockets—meal powder, 8 oz. ; steel-filings, 2 oz. ; charcoal (about as fine as single F powder), 1 oz., rammed with 8 blows of monkey, with a fall of 20 in. to each ladleful of charge. The same composition for a four-ounce rocket, reducing the blows of monkey to six. This is a very brilliant charge, and leaves a fine tail in the ascent. Eight-ounce rockets—meal powder, 16 oz. ; nitre, 10 oz. ; sulphur, 2 oz. ; charcoal, 2 oz. ; with five blows of monkey. The solid charge over the top of spindle should be $1\frac{1}{2}$ diameter.

Purple.—1. Chlorate of potash, 2 parts ; black oxide of copper, 1 part ; sulphur, 1 part. 2. Nitre, 25 parts ; nitrate of strontia, 25 parts ; sulphur, 4 parts ; realgar, 2 parts ; lampblack, 1 part.

Blue.—Nitre, 6 parts ; sulphuret of antimony, 1 part ; sulphur, 2 parts ; lampblack, 1 part.

Green.—1. Barium nitrate, 77 parts ; sulphur, 13 parts ; potassium oxymuriate, 5 parts ; metallic arsenic, 3 parts ; and calamine, 2 parts. 2. Nitrate baryta, 16 parts ; chlorate of potash, 8 parts ; sulphur, 4 parts ; sulphurs of antimony, $\frac{3}{4}$ part ; charcoal, $\frac{1}{2}$ part. 3. Nitrate of baryta, 84 parts ; realgar, 4 parts ; sulphur, 16 parts ; lampblack, 2 parts.

Yellow.—Nitrate of soda, $74\frac{1}{2}$ parts ; sulphur, $19\frac{1}{2}$ parts ; charcoal, 6 parts.

White.—1. Magnesium wire and chlorate of potash. 2. Nitre, 6 parts ; sulphur, 2 parts ; meal powder, 3 parts.

Fire-Balloon Construction.—Procure a quantity of coloured tissue paper, some paste made by mixing flour with water till of a creamy consistence, and then boiling it till thick. One ounce of alum to a quarter of flour improves the quality. Purchase about three feet of stout wire for a hoop, a little light wire to suspend the sponge, tow, &c., saturated with spirits of wine or other light burning liquid. Make the paper into gores, the shape of which can be arrived at by dividing a well-grown pear into six or more parts, then taking the rind off one of the parts and laying it flat. The greater the number of gores the more trouble, but the greater the probability of

symmetry. It is seldom advisable, however, to have more than twelve gores, unless the balloon is to be a very large one. Join the gores in twos; first let them dry, and then in fours, and so on, never having two sides of a gore wet at the same time, or your patience may be tried by one side parting whilst the other is being pasted. When all the gores are joined, finish the top by pasting on it a circular piece of paper, to which is attached a loop of string or wire to put a stick through as a support during the inflation. Fasten the hoop in the neck with thread, pasted paper, &c.; light and suspend the sponge.

Pharaoh's Serpent.—This curious toy really constitutes an interesting chemical experiment. It consists of a little cone of tinfoil about an inch high. This cone is lighted at its apex, when there issues from it a thick, serpent-like coil, which continues twisting and increasing in length to an almost incredible extent. This coil is solid, and may be handled, although it is very fragile. The white powder with which the cones are made consists of sulphocyanide of mercury, which, when heated to a temperature below redness, undergoes decomposition, grows in size, and produces a mixture of mellon (a compound of carbon and nitrogen), with a little sulphide of mercury. It is yellow on the exterior, but black within. The "serpent" shape, of course, results from the salt being burnt in a cone of tinfoil.

Electrical Machine, How to Make.—Having procured a cylinder $6\frac{1}{2}$ in. long and 4 in. in diameter—cost half-a-crown—you will require a stand. Take a piece of wood 8 in. by 7 in. by $\frac{3}{4}$ of an inch thick, which will form the bottom of the stand. Two uprights support the cylinder. Let these be about 7 in. high by 3 in., and of the same thickness as the piece forming the bottom, and let them each have a hole made in them, about $5\frac{1}{2}$ in. from the bottom, to admit the ends of the axle of the cylinder to revolve freely, but not too loosely within them; these must be screwed on to the bottom piece (the cylinder having been first put in its place with the handle end *to the right*). The cushion is made of wash-leather stuffed with wool, fastened to a piece of wood 4 in. long by $1\frac{1}{2}$ broad and $\frac{1}{2}$ an inch thick, at right angles to another piece, so that when fastened to the stand it shall press softly and evenly against the side of the cylinder. This cushion should have attached to it a piece of black silk as broad as the cushion is

long, and of sufficient length to hang over the cylinder to within $\frac{1}{2}$ an inch from the metallic points of the conductor. The cushion should fix in a hole on the front side, or the side nearest half to you, when the handle is to the right. When the machine is to be put in motion, the cushion is to be smeared with an amalgam which costs sixpence per oz.

You now want a conductor. Stick some (five) pieces of wire, sharpened at each end, into a cylinder of wood covered with tinfoil. The cylinder is to be 4 in. long and 1 in. thick, rounded at each end, and fastened at right angles to a piece of glass rod of such a length that the points shall touch, and only just touch, the side of the cylinder. A piece of wire, with a brass ball at its extremity, is to be fastened to one end of the

conductor, to which you apply the knob of the Leyden jar you wish to charge. Paint your machine, and everything is ready for operation.

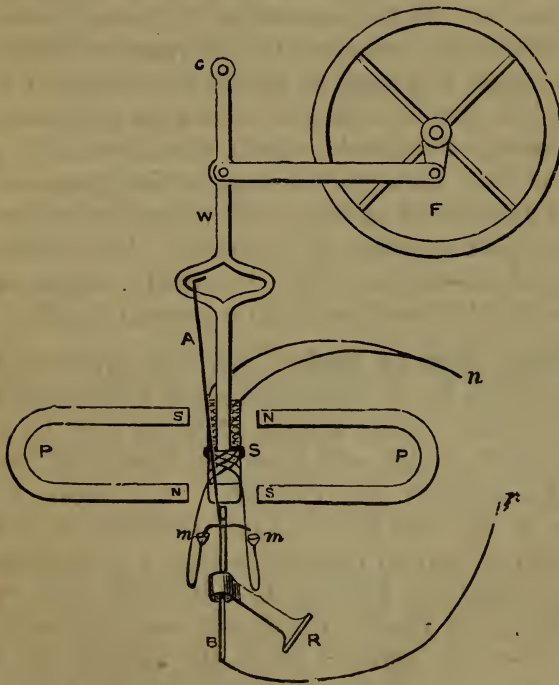

Electro - Magnetic Engine. —

PP, two permanent magnets ; S, a bar of soft iron covered with two coils of wire, a left hand and a right hand coil ; MM, two cups with mercury ; B, a bar to move in R ; a rest, with two arms to dip

alternately in MM ; A, an arm being moved by W, the beam ; F, the flywheel ; C, being stationary ; P and N the positive and negative poles of a battery. As soon as the current is set on S, the bar of soft iron is turned into a magnet, so that it is drawn by one of the P magnets and repelled by the other, next the current is set into the other coil by the movement of

A and B, which reverses the poles of S, the bar of soft iron, so that it is drawn by the magnet that repelled it before and repelled by the one that drew it.

Magnetic Engine.—By this plan it will be seen that by enlarging GG and E, and attaching magnets, greater power will be obtained. When E is down, the current is sent into the top magnets by the spindle KKK, and drawn up again, and *vice versâ*, the current never being allowed to be in both top and bottom magnets at the same time, which, if properly arranged, the spindle and springs will prevent. The soft iron, E, should be allowed to approach as near the faces of the

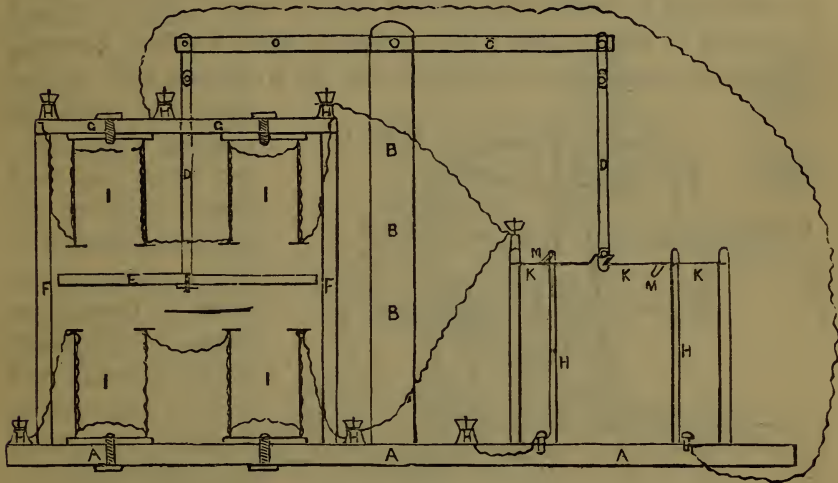

magnets as possible, but never allowed to touch, or it will stick and retard speed of engine.

AAA, the bed, to be made of hardwood; BB, support for beam; CC, the beam; D, connecting rods; E, soft iron plate for magnets to act upon; size according to number of magnets, of course. FF, supports for magnets; GG, cross piece for top magnets to be fastened to, and to be made of hardwood; H, brass terminal clamps for the battery wires, *i.e.*, the clamps that are disengaged. III represent magnets made of 1-inch soft iron 4 in. long, and each core covered with five layers of number 16 cotton-covered copper wire. K is the spindle and crank motion, to which is attached two projections for making

and breaking contact with the springs facing them, which are shown at HH, and which reverse the current from one set to the other, one of these projections touching each spring at every half revolution of the spindle.

Electro-Magnetic Engine for Small Battery Power.—A is the beam, B the wheel, C the pillars for wheel, DE the magnet, which, if the stands be about 6 in. high and the other parts in proportion, should be about $2\frac{1}{2}$ in or 3 in. long, with soft iron core $\frac{1}{2}$ in. thick, and should be wrapped with about half a pound of covered copper wire. This magnet is fastened down on the base, between the stands, as shown; F is one of two oscillating iron arms made in one piece similar to fig. 2, the distance between this arm F and H must slightly exceed the length of the magnet; this armature must be fixed between the stands to oscillate on the centres K, from one side to the

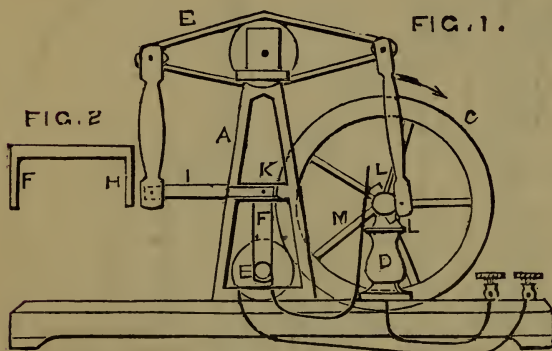

other of core of magnet (the magnet being fastened down between the two arms), thus giving motion to the lever I, thence by means of the beam to the crank and wheel. The current breaker consists of two revolving arms

L, which strike alternately on the spring M, two contacts being made during one revolution of wheel. The breaker action is as follows:—Suppose the wheel to revolve in the direction shown, and the crank to be at bottom, it will be seen on examination that one arm of breaker will touch the spring M, thus completing the circuit, while the armature F will be on the left side of the magnetic core. The galvanic current now flowing through the copper wire magnetizes the core, which immediately attracts the armature, and draws it downward till opposite the core, when the breaker leaves contact with the spring, stopping the current and destroying the magnetism (otherwise it would hold the armature and prevent its moving to either side), thus allowing the arm to complete its oscillation, and the crank one-

half revolution. At this point the other arm of breaker touches the spring, the current again flows, the former action is repeated the other way, and the crank completes the remaining half revolution. The wire ends of magnet are connected one to one terminal, and the other to the spring as shown, while the other terminal is connected to one of the pillars of wheel, the spring is not allowed to touch any conducting part except the breaker in its revolutions.

Electro-Magnetic Engine.—The peculiarity of this machine is the construction of the electro-magnets. BB, fig. 1, are two

hollow wooden cylinders, and round them is coiled a great length of covered copper wire, No. 16. There are two cores of soft iron, the one XPX, which is fixed, reaches half-way up the cylinders BB; the other, KLK, is movable, and enters without friction into the cylinders. To this core is attached a rod R, which is used as a connecting-rod. In this engine (fig. 2) two of these electro-magnets are used, their movable cores, MK, being suspended from the working beam EFG, which

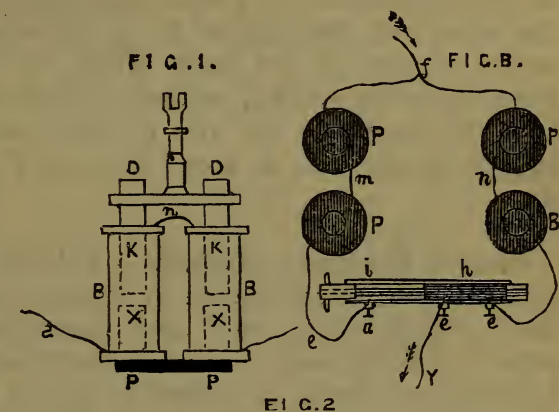

is prolonged to A, where a connecting-rod, AK, gives motion to the fly-wheel by the crank KL. Now, when a voltaic current is made to circulate in the electro-magnets, both cores become powerfully magnetized, and in opposite directions,

therefore they attract each other ; but the one being fixed, the other is drawn down, thus giving motion to the working beam. By sending a current alternately round the two electro-magnets, the beam is made to oscillate at the point F. The way in which the current is so changed from one electro-magnet to the other is thus :—The axis of the fly-wheel carries an eccentric, which gives a reciprocating motion to a slide *ii*, of ivory, covered in a part of its length by a brass strip *h*; a copper wire, *c*, is bent so as to press continually on the brass strip, and which wire also is in communication with the zinc of the battery by the wire *y*. Two other wires, *ac*, press on the slide *ii*, and communicate, one with the magnet *p* by the wire *e*, and the other with the magnet B by the wire *g*. The reciprocating motion of the slide brings the strip, *a*, alternately under the wires *a* and *c*, so that the current is made to flow from the battery by the wire *f*, either round the coils B, and by *ghby* to the zinc, or round the coils P and by *eahby* to the zinc.

Simple Electrical Machine.—This consists of a disc of strong paper, 30 centimetres in diameter, mounted on an axis made of glass tube or some other nonconducting material, and capable of being made to revolve about fifteen times in a second by means of wheels, an endless band, and a handle. In front of the disc are two metallic rods, having pointed extremities, which are perpendicular to the disc, being turned towards it, and at equal distances from its centre. The remaining portions of the rods are bent perpendicularly, one up and the other down, so that the metallic balls on their other extremities may be at an adjustable distance from each other. The apparatus is charged by placing a sheet of paper that has been well dried at the fire, and electrified by friction, very near, but not in contact with the disc, opposite to one of the pointed collectors, but not at the same side of the disc. On turning the machine, a luminous jet will pass between the balls. If the disc is covered with gum lac, and sheets of paper oppositely electrified are placed opposite the points of the collectors—one sheet being opposite to each collector—the intensity and duration of the effects obtained will be greatly increased. When the experiment is carefully made, sparks, five centimetres in length, will pass between the balls, and a Leyden jar, the

coatings of which are connected respectively with the latter, will be charged with great rapidity.

Constant and Cheap Battery.—For telegraph purposes there are two batteries which possess these qualities in a high degree. The first is Mr C. V. Walker's platinized carbon battery, and a modification of Daniell's. Mr Walker's is much used for railway telegraphs. In constructing it, it is best to have the graphite plate about 2 in. higher than the jars, and the connecting strips of copper should be well tinned and carefully riveted as near as possible to the tops of the carbons, and then well coated with shellac varnish; this prevents sulphate of copper falling into the cells.

The second battery referred to is as follows:—1 is a flat copper cell, having a piece of leather secured between two sheets of perforated copper on one side; 2, side view of the same cell; *a*, copper cell; *b*, *b*, perforated copper; *c*, leather; 3, a cell of the battery complete. The whole of the outside of the

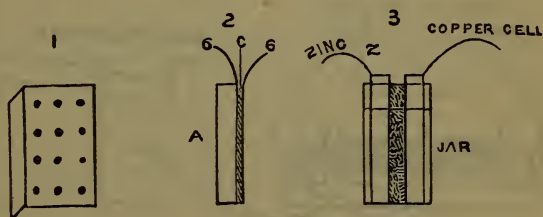

be well varnished, and the perforated side placed opposite a piece of very stout unamalgamated zinc in a stoneware or other jar. The outer cell is merely charged with water, and the copper one filled with crushed sulphate of copper moistened with water. It is obvious that several cells of this battery are required for a telegraph owing to its feeble intensity, but we are informed it remains constant between twelve and eighteen months.

Flower-Pot Battery for Electrotyping.—Common red flower-pots will answer the purpose of porous battery cells. Wood diaphragms, ox-gullet, brown paper, prepared canvas, &c., have all some fatal objection, which precludes their use where long and constant action is desirable. The form of action used with success is a modification of Daniel's, wherein the common red flower-pot is made to do duty as a porous vessel, and, when properly selected and prepared, it answers the purpose exceedingly well. Other advantages of this battery

are, that nitric and other acid fumes are dispensed with; it is the least costly to construct, no amalgamation required, and is easy to manage in the hands of an amateur or inexperienced person.

Electric Battery.—It is not necessary that the plates of zinc and lead be rolled up together, provided the battery jar is large enough to admit the plan. You cannot roll up amalgamated zinc plates in consequence of their brittleness. A is the primary battery, B the induction coil, C the secondary battery, D, stand for the coil, showing the ends of the wire connected to the binding-screw E, on the one side, and the other end connected with the spring of the contact-breaker F. The other portion of the contact-breaker G is connected to the binding-screw H. The zinc of the secondary battery is connected to

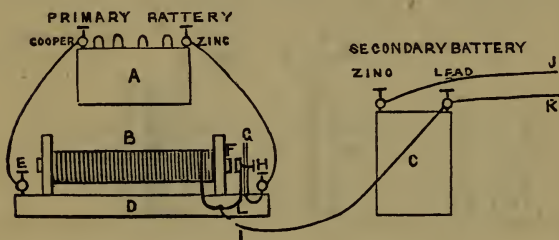

the binding-screw H, and the lead connected to the primary coil of wire as shown at I. The connections from the primary battery are from zinc to H, and copper to E.

You will now be able to understand the arrangement, as there is nothing very complicated in it. J and K are wires leading from the secondary battery for experiments. If any other form of coil be used, the same plan of connections must be adhered to. When setting the machine in operation the screw of the contact-breaker must be brought in contact with the spring portion, and as long as the vibration of the contact-breaker continues the operation is going on. The peculiar arrangement of the connections is made in this manner, so that we may obtain the extra or dynamic current, which is only produced at each break of the contact-breaker. This extra induced current, being in an opposite direction to the inducing primary current, passes only in the direction of secondary battery. The formation on the lead of peroxide of lead by the decomposition of the electrolyte causes the immense power of these batteries. Two plates of platinum may be used even in the place of lead and zinc, and then the secondary batteries are even more

powerful. The power of the platinum batteries depends upon the formation of oxygen on one plate and hydrogen on the other.

Earth Batteries.—Zinc and coke may be used with advantage in the formation of an earth battery. To construct one of this description, a sheet of zinc, about 1 ft. square, should be buried perpendicularly, about 4 ft. deep, in a moist soil, and the coke placed 3 in. from and parallel to the surface of the zinc plate. It matters little whether the wires leading from this battery be insulated or not; the value of an earth battery depends on the moisture of the ground it may happen to be placed in, the strength of current diminishing on the soil becoming dry, and increases when it becomes moist.

A simple and convenient form of earth battery may be formed by merely burying some coke, or a copperplate in the ground, to form one pole of the battery, and the gas or water-pipe can be used for the other pole. Either of the above forms of earth batteries would efficiently work an electric clock of the usual description, very small power being required. Earth batteries under the most advantageous circumstances are never very powerful, or, to speak more correctly, they rarely exhibit much "quantity," whilst induction coils can only be worked efficiently by the use of good "quantity" currents, on account of the thickness of the primary wire. "Smee's" arrangement of coil, of about a pint capacity, would answer. In the absence of information as to the gauge and length of primary wire, it would be well if different proportions of exciting solution were tried, commencing, say, from 1 part sulphuric acid to 12 water, up as high as 1 part acid to 6 water. It would then be seen which proportion suited the coil best. Smee gives good quality, is compact, easily managed, and very cleanly.

Another method.—A coke battery will be strong enough without the addition of zinc, and it is not necessary for the wires to be insulated. In making the earth battery there are several ways. Dig a hole about 3 ft. deep, and put two or three hundred weight of coke, and attach a wire in any way to the coke, and attach another to a gas or water pipe, and the battery will be complete. *Another way* would be, to attach a wire to a gas-pipe, and another to a water-pipe. This battery is strong enough to drive an electric clock. *Another battery*

can be made by attaching a wire to one of the pipes, and simply sticking the end of the other wire 3 or 4 in. in the ground; but the first battery will stand any length of time, and four or five electrical clocks have been worked at the same time on this battery, and is much superior to one in which copper and zinc plates are used. No earth battery will drive a shock machine.

Artificial Magnet.—Take a piece of round inch bar, 13 in. long, and bend it into the form of a horse shoe with the end strictly parallel; then get half a pound of covered copper wire, No. 16, and commence to wind on. The power may be increased by covering the iron first by winding on strips of silk, so that the surface of the iron is protected from contact. Leave a free end of about 3 feet for attachment to the battery, and begin about half or a quarter of an inch from the end, and fasten the first turn with a piece of packthread, and proceed to wind the wire on as closely and neatly as possible. It does not make any difference whether it is coiled to the right or the left, as it does not matter which is the north pole, and go right round the magnet, fastening the other end same as the first; the coils round the bend will be a little open at the outside, or it will not come square on the second limb. You may then attach it to the battery, and see if all is right; if so, varnish all over with red sealing-wax dissolved in spirit, and it is finished; but connecting one end of the wire will not be sufficient, as it is necessary that both ends of the wire should be attached to the battery to complete the circuit, or the magnetic influence will not be set up. With this magnet you can suspend 28 lbs., using a single pair, zinc and copper, same as for electrotype plates 6 in. by $3\frac{1}{2}$ in.; but an increase in the battery power would make it very much more powerful.

Electrical Machine—Regulation Coil.— A^1 , A^2 , are the two ends of the primary helix; B^1 , B^2 , the two ends of the secondary helix, which are in direct communication with the two binding screws to which the brass handles for administering the shock are attached. D^1 , D^2 , are two binding screws to which the battery is connected. To D^2 is soldered one end of the primary helix, but between the other end and D^1 the break must be fixed. A glance at the diagram will show the manner in which this is done. The brass tube used in some

coils for regulating the shock does so by shutting off the magnetism of the core of iron wires, or rather by preventing the primary helix from inducing magnetism in the bundle of wires; and it effects its purpose nearly as well as the drawing out of the bundle; for brass, although an excellent conductor of electricity, presents a most effectual barrier to magnetism, as may be proved by interposing a piece of plate brass between a permanent magnet and its keeper, when the magnet will be found to attract but very slightly.

For medical purposes the current should not flow only in one direction. Copper in combination with zinc does not evolve nearly so much elec-

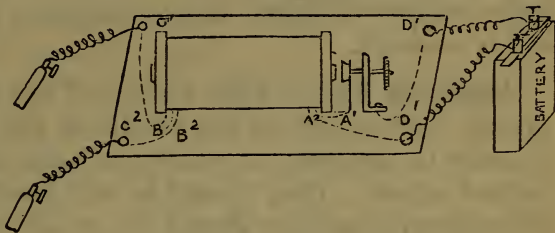

tricity as platinized silver, but a sheet of platinized iron will answer nearly as well. To platinize the iron, first clean it well, and then pour over it a solution of platinum in nitro-muriatic acid, which will cover the iron with a black precipitate, which is platinum in a state of very fine division. The iron must then be well washed in clean water. Varnishing the surfaces of the zinc, which does not face the platinized silver or iron plate, must in a measure save the zinc, and not prove detrimental to the power of the battery.

To regulate, coil gradually by means of a series of brass wires let into the stand, wind on the primary wire in the ordinary way, and bring out the ends from the secondary.

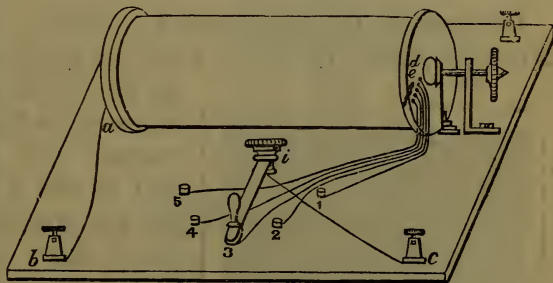

Before commencing to wind the secondary wire, bring out the end *a*, which will subsequently have to be soldered to the terminal *b*. Now lay on three layers, and without breaking the wire rub off a portion of the cotton or silk covering, and solder to the exposed part the wire *d*, which must be brought through the cheek of the coil, and will be afterwards

soldered to the brass knob 1. Next wind two more layers on, and repeat the above process, bringing out another wire *e*, which will have to be connected with the knob 2; and continue winding and bringing a wire out every two layers until the coil is full. In the coil represented there would be eleven layers of secondary wire. The other secondary terminal, *c*, is connected with the sliding arm *z*. It will now be seen that, by turning the handle to 1, but three layers of wire are in use; at 2 there are five, and so on, until at 5 the current circulates through the entire number of layers, and consequently the full power of the coil is obtained.

Amalgam Pad.—Take a piece of red leather 4 in. or 5 in. square, and spread on the middle of the rough side a small quantity of amalgam, to which has been added about 1-6th its bulk of tallow. They should be well blended together, and all the mercury that can should be pressed out. If this pad is kept dry and free from dust, it will answer for a very long time. To excite the machine, first remove all dust from the cylinder and stand with a warm dry cloth. Then turn back the silk flap of the rubber, lay the amalgam side of the above pad on the top of the cylinder, holding it in its place with a slight pressure with one hand while turning the machine with the other, and it will soon speak for itself. This will be a much cleaner and quicker mode than putting the amalgam on the rubber.

Condenser for Rhumkorff.—Take a sheet of varnished cartridge paper, 12 in. by 8 in., or larger if required, and lay on it a sheet of tin-foil 11 in. by 7 in., to allow half an inch margin all round; then at one corner lay a slip of foil 3 in. by 1 in. to serve for a connection, lay over that another sheet of varnished paper, then a sheet of tin-foil and a strip of foil in the opposite corner, and so continue building it up, being careful not to put two strips of foil following in the same corner, but alternately, first in one, and then in the other, so as to connect together every other sheet. The condenser for the Rhumkorff consists of 50 sheets so put together, enclosed in a

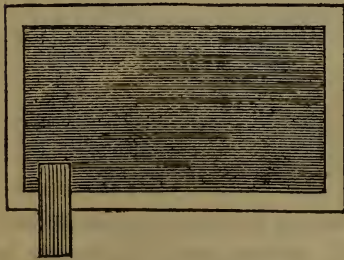

box for safety. The manner of connecting the condenser with the break of the coil may be seen in the annexed diagram.

The condensers are generally placed underneath the coil; but that the manner of connecting them may be the more easily understood they are drawn at the side. In those coils the primary wire is laid on in separate layers, with all the ends brought out, and so that by connecting the handle with the first piece of

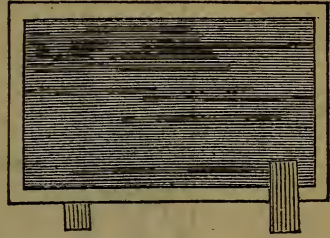

brass, the battery current passes only through the first layer, thus magnetizing the iron core but little, and rendering it capable of inducing

but a weak current in the secondary wire; but as the handle is moved onwards each successive piece of brass

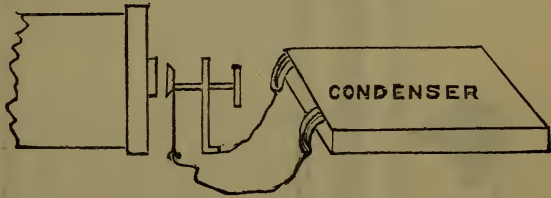

connects one more layer of primary wire, until at the last all the layers are connected, and the core becomes, when the current passes, highly magnetized, and capable of inducing a strong secondary current.

Another machine for covering wire with cotton, silk, &c., is made entirely of deal. A is a tube for carrying the wire through; B is a wood disc, which can be glued on A, carrying one or any number of reels; B, the covering material, which

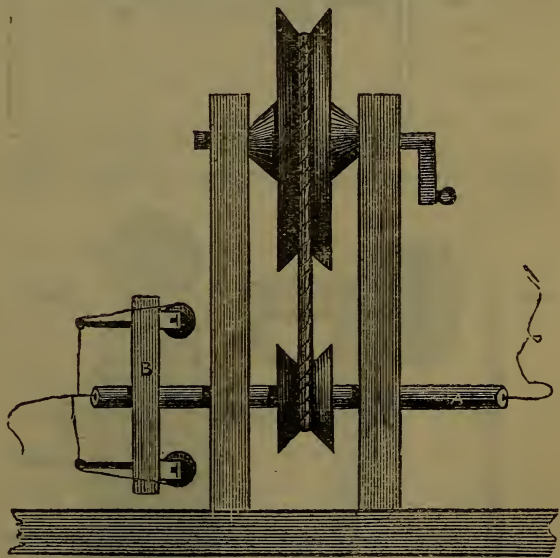

is passed through the disc and a wire eye, and on to the wire

to be covered. By turning the crank with one hand, and drawing out wire with the other, any length of wire can be rapidly covered.

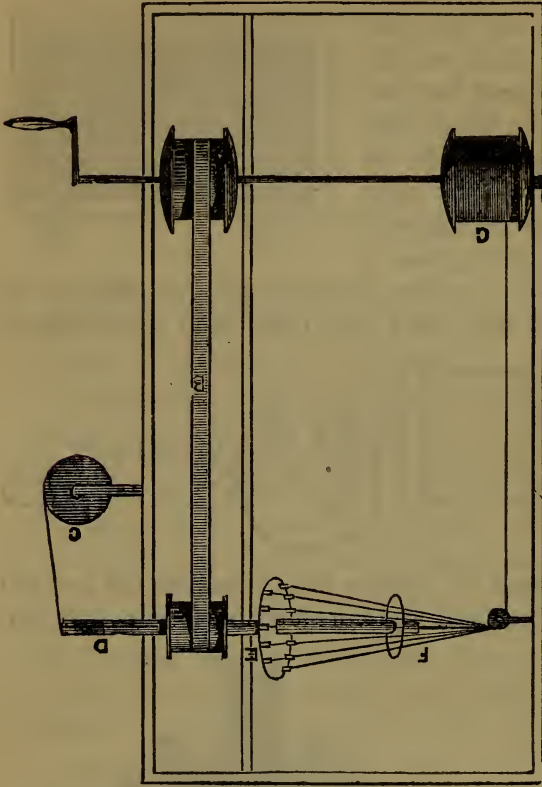

A third machine for use with cotton is thus made:—A is the handle for driving; B, the driving strap; C, the uncovered wire on the reel; D, $\frac{1}{2}$ -inch tube conductor; E, bobbin table with cotton bobbins mounted; F, round zinc table, with holes corresponding to number of bobbins; G is the receiver for the covered wire. The box containing the whole is of three-quarter stuff, and is 3 feet by $1\frac{1}{2}$ feet.

Another plan is thus described:—AA, sole of machine made of wood, into which are mortized the two uprights BB, only one of which is shown. They are placed about 3 in. apart. C, upright frame, for carrying shaft D and tube E; FF, two rollers for drawing through wire as it is covered; the top roller is made of lead, so as to give pressure to the wire to take it

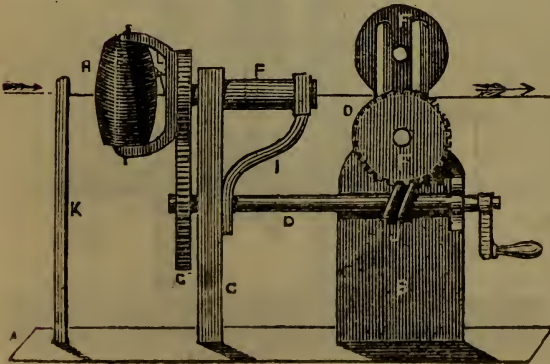

through; E, tube or hollow spindle through which the wire

passes; GG, speer-wheel, and pinion for driving hollow spindle and bobbin; HI, bracket for carrying end of hollow spindle; I, endless screw for working the pulley-wheel O, fixed on the outer end of the under roller F; R, support for steadying the wire as it passes through the spindle E; H, bobbin containing the threads for covering the wire; L is a small eye, fixed into the frame that carries the bobbin, through which the thread passes on to the wire. In using the machine, wire to be covered is held by the hands, and kept stretched as it is drawn through by the two rollers; another pair of rollers might be applied to keep the wire stretched the same as the drawing rollers. The speeds of the machine are as follows, viz. :—Large wheel 60 teeth, pinion 15 teeth, drawing screw 6 teeth to the inch, pulley for do. 35 in. diameter, drawing rollers 3 in. diameter.

Electro-Magnetic Clocks.—AA is a mahogany case, with a glass front; B is a metal bracket fixed to the back of the case, to which the pendulum D is suspended; NS are permanent steel magnets, fixed to the sides of the case in such a manner that the pendulum-ball D can vibrate freely between the poles of each magnet. The magnets are placed so that the poles of dissimilar names face each other. E is a small platinum ball, affixed to a brass stem, free to move to one side or the other, being fastened to a light spindle carried by the pendulum-rod at H. The plate of copper, F, is deposited in the moist earth, from which a wire, C, leads to the bracket B. The plate of zinc, G, is likewise deposited in the earth, and its wire leads to the piece of metal I. To the lower end of the suspension spring of the pendulum is attached a wire coated with silk. It is let down the back of the rod, which is wood, and then coiled longitudinally in many convolutions around the edge of the pendulum-ball in a groove previously made for that purpose.

It is then taken up the back of the rod, and terminates in the bearings of the spindle H. The action of the apparatus may be explained thus :—A constant and uniform current of electricity would be established, and would pass through the earth, the plates, and wires in the direction of the arrows, so long as the platinum ball E rests on the platinum pin projecting from the metal I. But if the pendulum is put in motion, suppose that, first, it were drawn aside until the ball D should

be between the poles of the right-hand magnet, the point H being now farther to the right than the ball E, the latter would fall to the left and rest on the pin K, until the pendulum took its vibration to the left, when the ball E would fall to the right; and so on continually, the action being produced by the change of the centre of gravitation at each vibration of the pendulum. This action of the ball E lets on and cuts off the flow of elec-

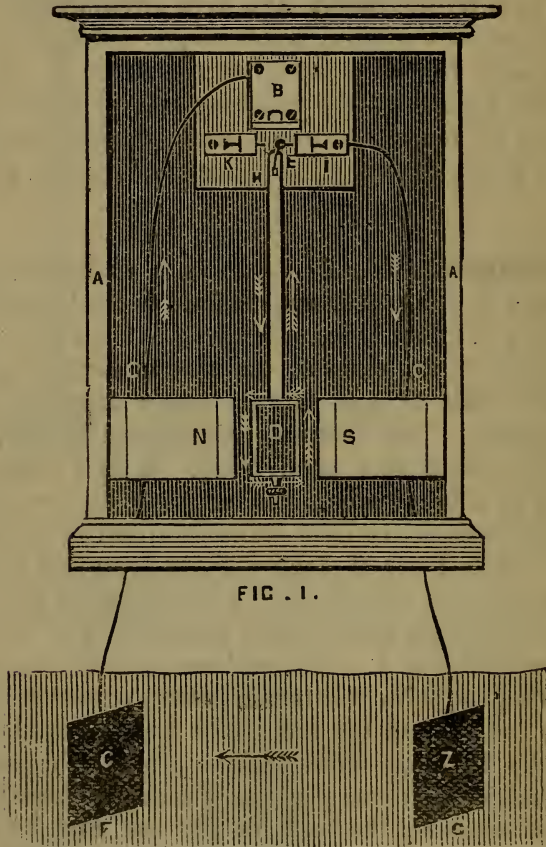
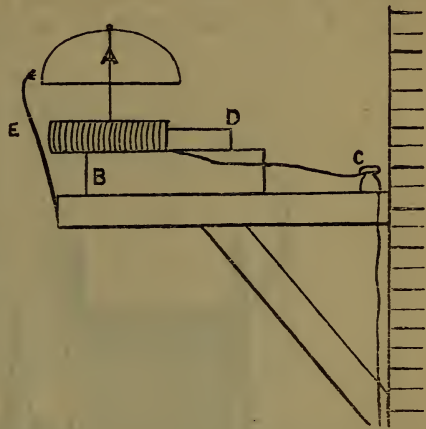

FIG. 1.

tricity at or near the extreme ends of the pendulum vibrations, so that the convolving wire of the pendulum-ball is attracted and repelled by the magnets at the proper points of its vibrations, and thus a continual motion is kept up for an indefinite period of time. No explanation is needed of the remaining portion of the clock.

Cheap Electric Bell.—This will work about 25 yards away from one small Daniell's cell. Total cost, 3s. 6d. A, bell; B, a small block of wood upon which the bell and magnet are placed; C, two binding-screws; D, a quarter of a pound of copper-covered wire, No. 16, for magnet; E, clock-spring for hammer.



Galvanometer.— Fig. 1 represents the machine when complete; fig. 2 the coils and needle, made of hardened steel magnetized; fig. 3 the needle and finger; fig. 4 the skeleton coil-boxes, covered with ten layers of No. 30 silk-

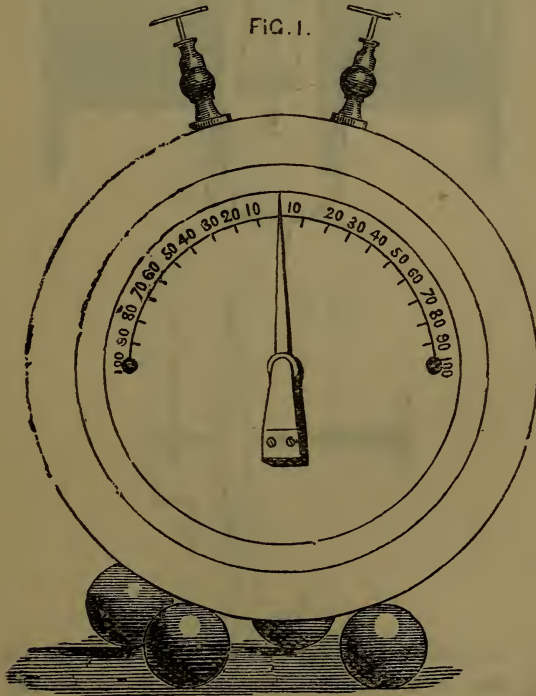

covered copper wire, for intensity purposes, but for quantity they should be wound with four layers each of No. 16 cotton-

covered wire. Figs. 5, 6, 7, should be made of ivory, brass, or bone, and when put together they will form the coil-box or frame, fig. 4, ready for winding on the wire. If the boxes are made of brass, they should be varnished with shellac varnish,

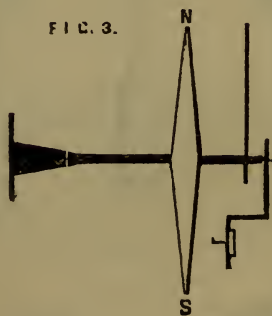
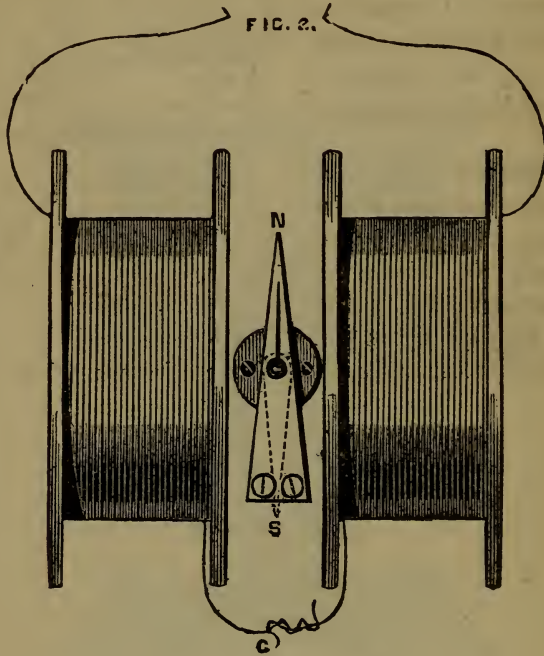

shellac and naphtha. The wire can be varnished when wrapped on the boxes, but the operator must be careful to wind the wire on both boxes, in the same direction, or he will not obtain any good effect. The two inside wires should

be joined together as at C, and the outer wires to the terminals on the case.

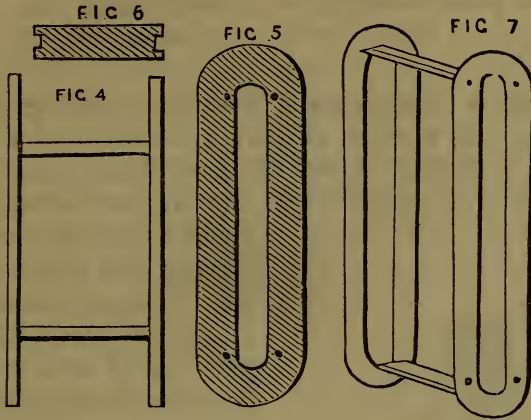

Rotating Magnet.—The following is the most simple form :
 —N, S, are the poles of a horse-shoe magnet fixed on a stand,
 W ; *a b* is a wooden cup for mercury, divided into two parts,
a and *b*; *a* is connected to one end, and *b* to the other, of a

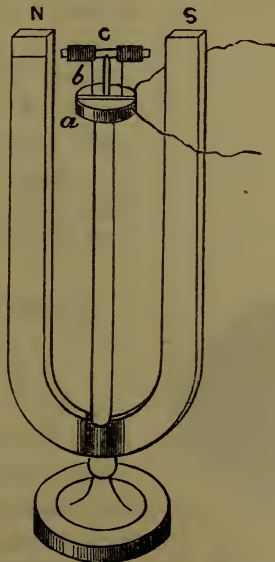

single-cell battery. C is the electro-magnet, consisting of a small bar of soft iron, surrounded at its ends with a continuous coil of stout copper wire, the two terminations of the wire dip-

ping into the mercury. The electro-magnet is supported on a central vertical axis, which passes through a collar, and terminates in a point, resting in a small agate cup, so that the electro-magnet is free to move in a horizontal plane.

Mounting a Magnetized Needle.—Having your needle magnetized, cut a piece of cork cylindrical of the following dimensions:—Height $\frac{1}{2}$ in., diameter $\frac{1}{4}$ in.; push the needle through the cork near the top, and in the bottom of the cork

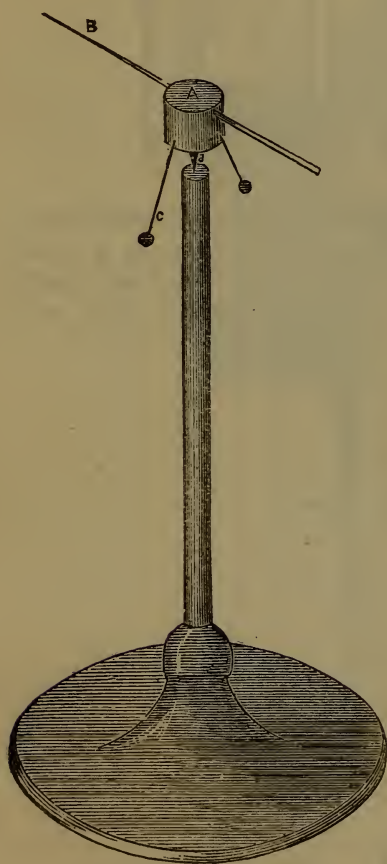

insert a part of another needle, leaving the point projecting $\frac{1}{4}$ in. Balance this on the top of a piece of glass rod by inserting pins loaded with small shot opposite each other on either side of the magnetized needle. The glass rod may be fastened to the foot of a wine-glass by means of a piece of gutta-percha, or wood, or brass. If the cork be varnished with sealing-wax varnish, it will be improved in appearance. The annexed figure will illustrate this arrangement. A, cork; B, needle; C, loaded pin; D, the point on which the whole is balanced.

Electric Telegraphy.—The battery, or generator of electricity, is the fundamental part of the electric telegraph. The two ends or extremities of a battery wherein electricity is generated by chemical action are termed *poles*—one of them the *positive*

and the other the *negative*. From the former the current of positive electricity issues, and from the latter the negative. Before the two metals of which a battery is composed are joined together no electricity is evolved, and when metallic

connection is established, the electricity simply makes a circuit; but it is the opinion of many eminent electricians that no particular portions of that circuit can be said to be either negative or positive to another portion.

There are two theories of the electric fluid—the single and the double fluid theory—and the student, while adhering to the single fluid theory, by which the action of the battery is generally explained, may confound the existence of two different electrical tensions in the conductor forming the voltaic circuit, with the idea suggested by the terms mentioned of *two* distinct currents passing through this conductor from each of the extremities of the battery.

Whichever theory of electricity is adopted, the terms *positive* and *negative* will be found equally convenient and expressive. To reverse the direction of the electric current, or to transmit alternate currents in reverse directions along the conducting wire, are expressions not liable to misinterpretation, if the words *positive* and *negative* are clearly understood.

The battery most suitable for telegraph purposes is the “Daniell.” These

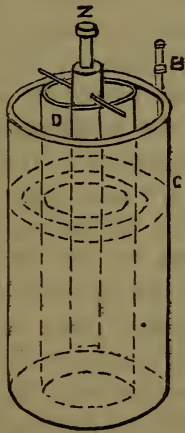

Daniell's Battery.

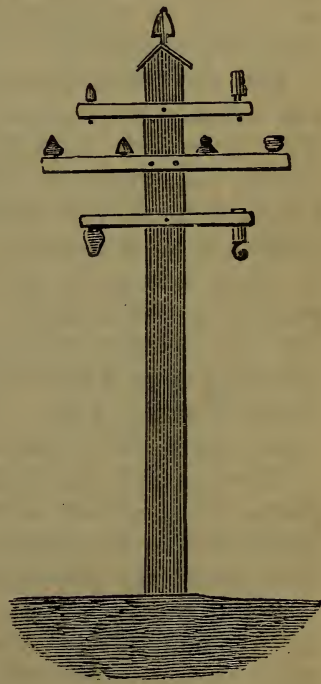

Pole with a variety of Insulators.

batteries are very constant, requiring very little attention, are not offensive in smell, and furnish a steady, reliable current. In making a “Daniell's battery,” not a little care should be taken to obtain a porous cell free from defect. Two extremes have to be carefully guarded against in selecting a porous cell; for either it may be over-fired, baked, or at too great a heat,

when it will not be sufficiently permeable by liquids, that is, it may not be so porous as to permit the liquid to pass through without rupture or displacement of its parts, or it may not be sufficiently baked, when any metallic solution will act upon and partly dissolve its substance.

To prove universal porosity of a cell, it is necessary to ascertain whether water will pass slowly, but entirely, through every part of its texture, or by touching it with the tongue when the amount of dryness produced by the absorption of the moisture will show the freedom with which liquids will pass. The more porous the cell is, the greater the quantity of electricity developed, and, therefore, the greater the quantity of metal deposited, as the degree of deposit is always in relation to the quantity of electricity generated.

The zinc plates should be well amalgamated, and the porous cell supplied with a saturated solution of sulphate of copper. Very little acid should be added to the water in the cell containing the zinc plate. The outward vessel is formed of porcelain, and consists of two battery cells. The copper element is immersed in a porous vessel containing sulphate of copper. In order to prevent as much as possible the copper solution passing to the adjacent cell, and its consequent action upon the zinc element, the porous vessel is saturated with tallow, excepting upon a portion of the surface which is directly opposite to the zinc plate. Instead of a porcelain vessel, battery cells constructed of ebonite are also employed with success.

The quantity and intensity of the electricity in the voltaic pile are respectively modified by the size and number of the plates, and by the action of the intervening liquid. When the zinc plates are perfectly clean, pure water produces certain electrical effects. These are considerably modified by dissolving common salt in it, or employing other saline liquids, but dilute acids are best calculated to increase them.

When the poles of the voltaic battery are brought near to each other in acidulated water or saline solution, or when these liquids are made parts of the electric circuit, so as to enable the electric current to pass through them, decomposition ensues, that is, certain elements are evolved in obedience to certain laws. The water, which is a combination of two gases, yields oxygen and hydrogen, and the neutral salts yield acid and alkalis. In these cases the ultimate and proximate appear at

the poles of the battery, not indiscriminately and indifferently, but oxygen and acids are developed at the positive pole, and hydrogen and alkaline bases at the negative pole.

The intensity of the electric current is dependent on the energy of the chemical action on the zinc, and the quantity produced in a certain space of time depends solely on the amount of decomposition produced, or the weight of zinc dissolved in the cell, in order to increase the number of cells containing voltaic pairs. The nature of the exciting fluid materially affects the resistance which is afforded to the galvanic current, for no strength of two fluids conducts the galvanic power with equal facility.

In making a galvanic battery, it is necessary to have two good conducting substances, separated by a good intervening liquid. The amount of action which it will produce will be proportionate to the ready action of the liquid on one substance and its inaction on the other, and will depend on the size and the power of the battery, but it is always lessened, first, by a slight resistance which the metals afford to the passage of the current; secondly, by the resistance which the intervening liquid is certain to afford, which is proportionate to its thickness.

If, instead of a good conducting metal, the connection between the terminal plates is made by any imperfectly conducting substance or any great length of wires, then will also the power be still materially decreased. One cell, containing two metals and an intervening fluid, provided it be large, is sufficient to produce any amount of action where no resistance is afforded to the passage of the electric current. These will remain inactive while they do not touch; but as soon as contact takes place, either in the exciting fluid at a distance, or through a fluid of more easy decomposition than the exciting fluid of the battery, the action immediately commences. The contact may be made through a great length of wire with the same result. In this case, however, if the wire be either long, of small diameter, or of a metal of no great conducting power, it will be seen that the hydrogen evolved from the negative metal will be materially lessened, showing that an obstacle is presented to the electric fluid.

In constructing a line of telegraph, some discretion is necessary as regards the selection of posts for the support of the wires. It has been decided that it is far better to suspend

wires than to bury them, owing to the liability of the insulating material employed for the encasement of subterranean wires to increase the expense of repairing faults ; therefore the majority of our inland wires are supported on wooden posts along the lines of railways or canals. The poles should be at least 5 in. in diameter at the top, and about 15 feet out of the ground and 5 feet in. The length of the posts must necessarily vary according to the locality in which they are placed. Young firs are generally used for telegraph service abroad, but in our country English larch is preferable. In Germany and America insulators have been put up on the stems of living trees,

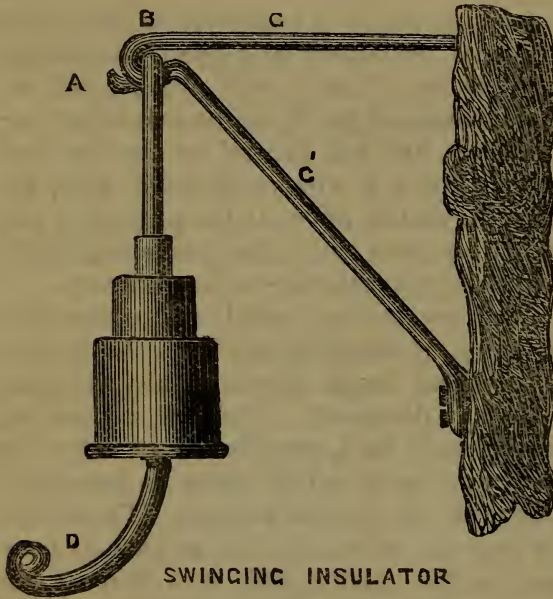

SWINGING INSULATOR

found to answer very well. This idea arose from the fact that the sap ingredients of the tree are the prime movers in the rotting of dead wood, and, in order to obviate the drawback to this system, occasioned through the violence with which trees are moved in heavy storms, Lieut.-Col. Chauvin constructed a swinging insulator. This contrivance is hung

upon a hook free to swing about (see engraving). The stalk is bent in a curve, away from the stem of the tree, that when the latter is deflected by wind, the line wire in swinging may not come into contact with it, the hook A, held in the loop B of bracket C, C', is twisted, so that in case of a sudden jerk the line cannot be thrown upwards, and the insulator disengaged from the bracket. The hook D is also bent over the wire to prevent the line jumping out. This is a very ingenious contrivance, and could be used with advantage in America, where lines have to be extended through forests. The number of

poles per mile average from 20 to 30. Iron posts are so arranged that they fit telescopically into each other; thus they offer great facilities for shipment, and can also be conveyed either by hand or by the cheapest mode of conveyance. Being furnished with turned and bored points, they can easily be put together. The similar portions of the poles are interchangeable. Should a breakage occur, the part which is destroyed can, therefore, be easily replaced.

The telescopic arrangement of the pole is also found advantageous in over-house telegraphs, as, after fastening the wires to the insulators, the pole can be raised or lowered at pleasure. The arrangement for fixing the insulators is admirably contrived.

The wire used for telegraph lines is No. 8 gauge iron wire, coated with zinc, galvanized, in order to prevent oxidation or rust. The zinc is applied to the surface of the iron while in a state of fusion. Zinc-coated lines have been used several years. When the rain first falls on the zinc covering, an oxide of zinc is formed, and this oxide being insoluble in water, a second fall of rain cannot dissolve or penetrate it. The zinc covering and the iron wire inside are thus prevented from rusting away.

Insulation is the next important matter connected with the electric telegraph; and although many forms of insulators, made of various substances, have been invented, proper insula-

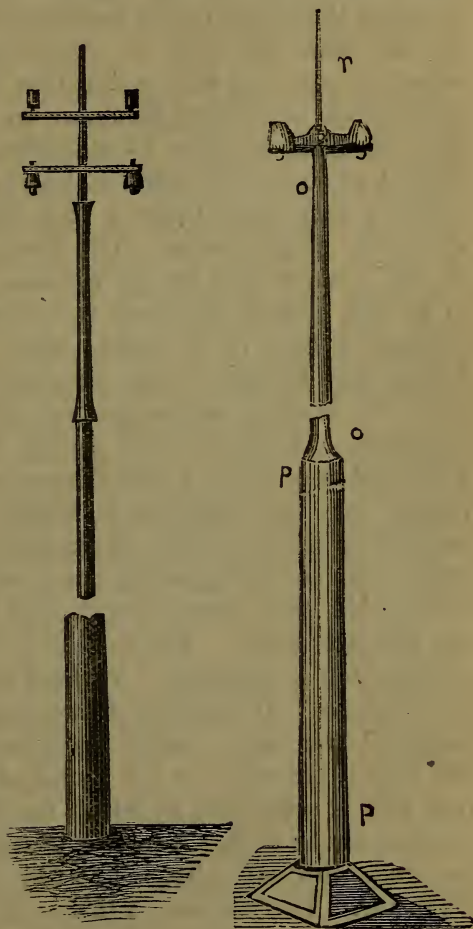

tion of our telegraph lines has not hitherto been attained. When the insulators are clean, and in dry weather, there is a loss at every point of support. In wet weather the loss is increased; and when insulation is imperfect, and heavy showers of rain occur, the loss is often so great as to completely suspend the working of the line. Certainly, much can be done by increasing the power of the batteries, still it is with difficulty that we can work the wires in wet or foggy weather. Glass insulators are covered with a thin film of water. Some electricity will escape over every insulator so covered with moisture; in fact, the glass becomes a conductor. As it is exposed to humidity, it attracts to its surface the aqueous vapours of the atmosphere; they form there a thin film of water, by which the electricity passes away. The first aërial insulator introduced in this country was an earthenware tube of the size and form of an egg, slightly flattened at the ends. The wire was passed through a hole in its longer axis. Porous earthenware and baked clay insulators are principally defective, from the fact that the body is so porous as readily and easily to absorb moisture. Whenever the glazing is broken through by the wire and the spike, a moist communication is at once established, and the insulator is highly imperfect. An objection somewhat similar holds against the use of gums, resins, and other non-conducting substances, less hard than glass, as the wire would soon wear through, and touch the pin upon which the insulator rests. The surface is also liable to gradual decomposition or exposure. Varley's insulator is extensively used in England. It consists of two cups cemented together with sulphur; the outer cup is provided with a groove, to which the wire is bound. In the recess of the inner cup a wrought-iron bolt is cemented, by which the insulator is attached to the bracket on the post. A further insulation is obtained by coating the stalk with vulcanite. The rim of the outer cup is rounded off inside. The purpose of this is to avoid the sprinkling of the interior with rain water, when a drop hanging upon the bottom rim is blown off by the wind. When a strong current of air separates a drop of water from a sharp corner, the drop is never carried bodily off, but bursts in the direction of the current. With the form given to the rim by Mr Varley, when a drop happens to hang on that side from which the wind comes, it is driven a little way up between the two cups, and does not burst.

Siemen and Halske's stretching insulator is shown in the diagram. It is made with a stronger and larger cast-iron bell than the ordinary insulator. The porcelain cup carries a stalk with two notches, through which the wire is drawn and wedged on each side, leaving a loop between them. In cold weather, when the line contracts, this loop allows the wire between the posts to be slackened, and also, in case of a rupture, gives sufficient space for making a joint.

The subtle agent electricity, that we see, feel, and know to be moving in things around us, is composed of minute particles unsusceptible of any further division, electricity being in that respect analogous to all other kinds of matter. The *induction* action starts into immediate existence on the slightest disturbance of the normal electricity. Distribution shows us the wire of the electric telegraph under two perfectly distinct aspects. It seems always to have been constructed for performing two different functions not generally known to be separable from one another either in theory or in practice. The causation in both cases has been too profound to be understood.

In both cases—electrical conduction, as well as electrical charge, distinct though they be when considered as results—there is in operation for attaching plus electricity to neutral matter a cause that we have not yet made known. Imagine a spherical particle of common matter to have a portion of its surface occupied by comparatively minute portions of electricity, attracted towards its centre as part of its natural electrical equivalent, then three things will become apparent. First, that the particular particle of common matter will have room to receive upon its surface some additional number of electrical particles. Secondly, that that particle, without attracting a larger total quantity of electricity, can attach to its surface an additional number of electrical particles if placed upon it, because some part of every one that will be so placed must be nearer to the common centre of attraction than all the parts of any one of them. Under these circumstances, the parts that are nearest making up in their total a quantity required to complete the electrical equivalent will be held by attraction, the remaining parts not attracted by the common centre will be attached to the particles of matter by the indivisibility of the particles, and be to it a plus charge. The third thing that will become apparent is, that as many particles of electricity as

shall be so placed on one side of the surface of a common particle, in addition to its natural equivalent, may, if an adequate removing cause be in operation, be taken from it at the same or any other side without the particle of matter losing its normal quantity.

Apart from the consideration of all surrounding circumstances, the electrical condition of the particles of common matter just described may be the condition of all the particles throughout the whole substance of a conductor in its interior as well as its exterior portions. If then, in practice, we find the condition to be at any time limited to any particular part of a conductor, we must conclude that its locality is alone determined by surrounding circumstances for the time being. No conductor can appropriate to itself absolutely a single particle of plus electricity, common matter universally having had assigned to it at its creation a particular and unchangeable quantity, so that any additional particle that may be placed upon it, it can only hold, as it were, in trust for some rightful owner, on the conditions called *artificial electrical equilibrium*.

The *artificial electrical equilibrium* is that state of matter which becomes established whenever plus electricity, exerting attractions for its equivalent of common matter from which it is temporarily separated, acts upon surrounding non-conducting neutral particles virtually, though by reason of their insulating nature not actually dismissing from them some of their natural electricity, and causing the same action to be propagated to progressively increasing quantities of insulating matter until, by reason of electrical law of the squares of the quantities, the intensity becomes so reduced as to be insensible on our most delicate instruments. This, the ordinary form of *artificial electrical equilibrium*, is sometimes somewhat modified by the intervention of neutral conducting matter, which, if it be near enough to sustain the induction, can actually as well as virtually relinquish a portion of its own electricity, and thus promote the reduction of intensity, especially if the electricity relinquished cannot pass into earth, from the surface of which it can act inductively with an intensity that may be regarded as infinitely small. As the facilities for the reduction of intensity increase, so will, of course, the charging capacities or quantities of plus electricity, susceptible of being held under any specified

intensity, and, owing to this law, if a conducting surface have contiguous to it another conducting surface communicating with the earth, it can receive upon it under a given intensity far larger quantities of charge than when it is simply surrounded by air. Considering, then, that the distance at which the electrical attraction may be acting between a common particle and its electrical equivalent is shortened by an accession of plus electricity, and that plus electricity on the surfaces of common particles can have the intensity of its attraction reduced to an insensible amount by induction, we can understand plus charge to be both possible and in perfect harmony with the doctrine of limited electrical attractions. Now, when we lay an insulated telegraph wire between two distant places, and deliver electricity continually into one of its extremities with greater rapidity than it can find its way out of the further extremity put to earth, it is impossible not to charge its surface, and that charge may have an intensity of action to any amount not exceeding the source from which the plus electricity is delivered.

This is true, whether the further end of the wire be freely uninsulated or insulated. We can surround a long conductor with a cylindrical vacuum of diameter large enough to put common matter beyond the reach of induction, or we might establish a telegraph wire with perfection; for, under such circumstances, electricity would either not enter the wire at all, or only do so in order to arrive through it at some charging capacity at the other end, capable of holding it under an intensity below that of the source. At the best, our telegraph wire has a very similar capacity for charge derived from the air around it.

And even the degree of imperfection is always necessarily abandoned for a worse whenever the circumstances of our locality constrain us to convert naked wires into "cables" for the purpose of their "interment" or submersion, for in either of these cases the solid insulating material by which the wires are enveloped for maintaining their charges is far too thin to keep the external conducting matter at an effectual distance, and thereby preventing it from dismissing by induction comparatively large quantities of electricity to find on the surface of the earth or sea a lower intensity of charge than could otherwise be afforded. The greater charging capacities thus occasioned are known practically to give rise to evils of enor-

mous magnitude, and of which every telegraphist is sufficiently sensible.

We now reach the laws of electrical conduction as applied to electro-telegraphy, and we will proceed with the following simple experiment. Place upon a large insulated sphere a plus charge, and against it on either side an end of an insulated rod, one of the sides being of metal and the other of glass, dry and clean. Part of the charge will immediately distribute itself over the surface of the conductor, but not over that of the non-conductor. Remove the glass rod, and slide the numerous parts of its surface into contact with the charged sphere. Then, upon removing it, it will be found with a plus charge distributed upon those parts of its surface like the other rod. In this experiment, had not conduction been a preliminary necessity, charge would have ensued along both sides of the rods directly they were placed with their extremities against the charged surface of the intermediate sphere, for both cylindrical surfaces were susceptible of charge, as is proved by the two being ultimately found plus electrical. It is proved that, although it should be possible to have conduction along a wire without charge with the attendant induction, we cannot have the reverse of this, that is, a charge on the wire or its induction, unless the wire has previously acted in some way as an electrical conductor.

Let us now endeavour to explain more minutely the nature of electrical conduction along a telegraph wire. For the sake of simplicity of conception, suppose the insulated wire to consist of only a single line of particles of common matter, and that we present to one of its ends a quantity of plus electricity, emanating from a source maintained at a given intensity by virtue of the shortening distance, as before explained, the common matter of the line acting by ordinary electrical attractions, will attach to itself the electricity so presented.

Now, if the line be insulated at its further end, the electricity will be held by it as a plus charge under some intensity, not exceeding that of the source from whence it is derived; but if, on the contrary, the further end of the line be put to earth, or other sufficiently large mass of conducting matter, surrounded by air, and the supply of electricity be not too rapid, then conduction and not charge will ensue, for immediately that a particle of plus electricity enters the wire

at one end, another particle of electricity, natural to the other end, will leave it—all the common matter of the line still possessing its normal equivalent of electricity, because every one of the common particles will have acquired an electrical particle from its neighbour, situate between itself and the source of the plus charge. It may be that each of the common particles in the conducting line is capable of so parting with two, three, or some greater number of particles of electricity simultaneously, and in proportion as it can do so will it be the better electrical conductor; but its capability in that respect must have a limit, and instead of a single line, as we have supposed, every wire will, of course, have some large number of such lines bundled together proportionate to the area of its sections; from which it follows, all other conditions being constant, that its conductivity will be as its area multiplied into the number of electrical particles that each common particle can charge with its neighbour. So far, therefore, as the wire is concerned, charge and conduction differ chiefly in this—in the former the plus electricity of the source passes from it to the wire to act from its surface

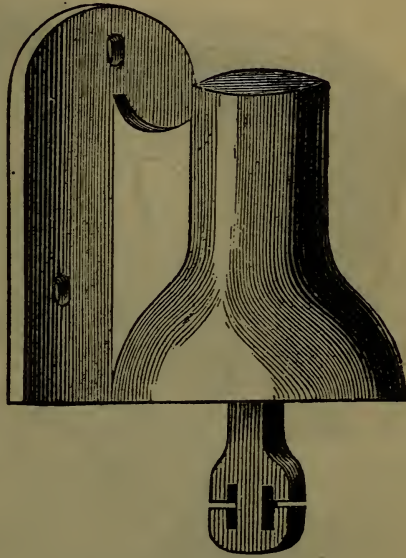

Siemen and Halske's Insulator.

with a diminished intensity on the surrounding air, and, in the latter case, it is handed on from particle to particle of the wire to be conveyed to some other conductor, having a charging capacity that will enable it to do the same thing; and either of these results will take precedence of the other, as the surrounding circumstances shall enable it to be accompanied by the lower intensity. If the plus electricity meet with less inductive reaction by remaining in the wire than by passing out of it, charge will take precedence of conduction; on the contrary, if the plus electricity can pass out of the wire to a lesser amount of inductive reaction, then conduction

will supersede charge, and therefore it is that conduction is consequent upon uninsulation and charge upon insulation of the wire. This is the theory of an eminent electrician of the present day.

Alphabetical Dial Telegraph.—The Voltaic Alphabetical Dial Telegraph Instrument was formerly made by Breguet in

FIG. 1



three separate parts, namely, the manipulator, receiver, and the alarm bell. The three parts are now combined in a

compact case. In fig. 1 we have a view of the case open, showing the face of the receiver and the plate of the manipulator with the handle. As will be seen in fig. 2, another part of the case is hinged, and is capable of being opened. On the

FIG 2

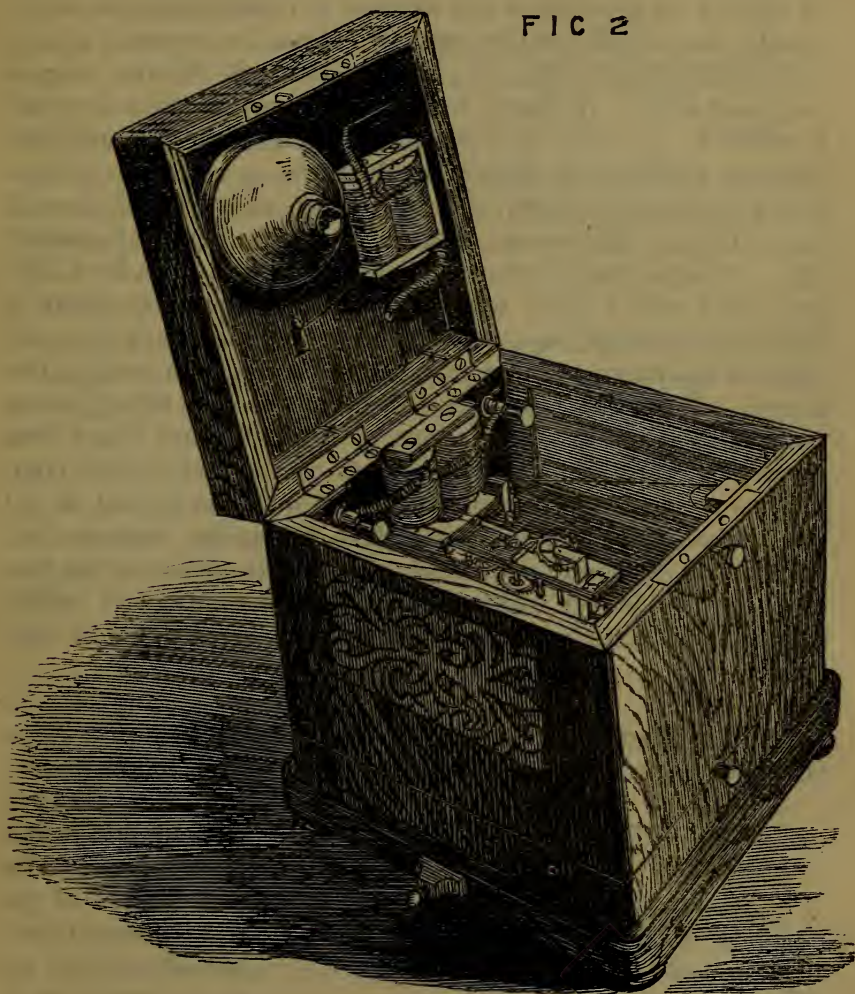

inside of the lid of this part is screwed the bell, which is an ordinary "Tremulo" bell. At the bottom of the two sides, and at the back of the case, are placed brass terminals, to which are connected the line wire, the battery wire (copper), and the

earth wire. By turning the handle on the dial-plate once round, we send, by means of a "cranked" arm not shown in the drawing, thirteen copper currents on the line, or half as many currents as there are signs on the dial-plate; these, entering the instrument at the distant station, cause the hand or pointer on the face of the receiver to revolve once round, or should the handle at the sending station be stopped at any letter, the pointer at the receiving station will likewise stop at the same letter. A glance at fig. 2 will serve to show how this is effected. A train of clockwork, which on the average only requires winding up once a week, drives a common ratchet-wheel with thirteen teeth, the shaft of which is carried through to the face of the receiver, and on which the pointer is placed. This ratchet-wheel is released, half a tooth at a time, by a light rod, fitted with a catch, which is attracted to the armature of the electro-magnet, as it is attracted to or pulled back from the poles of the magnet—an attraction and a repulsion making two letters. When the case is closed, by means of a spring and a point seen at the left-hand corner of fig. 1, the bell is put into circuit, so that when a current travels on the line the bell commences to ring, and continues to do so until the arrival of the clerk, who opens the case, and thus brings the receiver into circuit. It is possible to work these instruments at the rate of twelve words per minute, and a Daniell's battery of twelve elements is quite sufficient for a distance of four or five miles.

Simple Electric Telegraph.—The base consists of a piece of mahogany 8 in. square and 1 in. thick, with a hollow groove

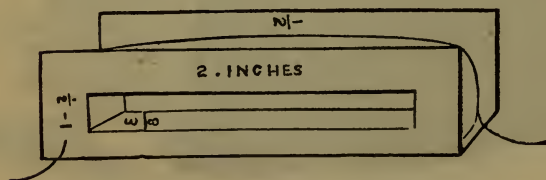

cut in its centre 2 in. long and a half inch wide. The coil consists of 50 ft. of covered copper wire, No. 30 gauge, wound on a

frame of card $1\frac{5}{8}$ in. long, $\frac{1}{2}$ in. broad, $\frac{3}{8}$ in. deep in the open part; an edge or flange of card $1\frac{1}{2}$ in. wide, 2 in. long, is stuck to each side to keep the wire in its place. Now commence winding the wire at the lower left corner, and wind from right to left. Each end of the wire must be stripped of the cotton,

so as to have the wire clean for the electricity to pass. The coil is mounted in the stand by inserting the two lower edges in the groove, so that the floor of the coil is level with the stand. The needle is 1 in. long, 1-12th of an inch wide, of hardened and thin steel, and fitted with a brass

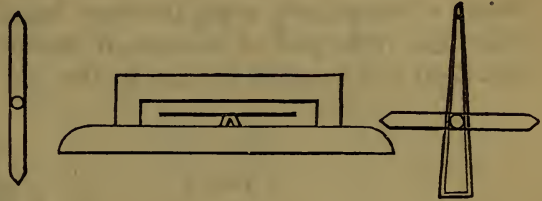

cap turned to a true cone, to receive the steel point on which it is to be balanced. The needle is then to be magnetized by drawing it across the face of a common horseshoe magnet three or four times. This needle is now balanced on a steel point 3-16ths of an inch high, soldered into a copper slip 2 in. long. Now glue on the needle a piece of glazed letter-paper, tapering from $\frac{1}{8}$ in. to a point, and 2 in. long, at right angles to the magnetized needle. To limit the vibrations of the paper index, drive two copper pins in the base $\frac{1}{2}$ in. away each side of the index. Place outside the coil a small magnet at right angles to the coil to keep the paper index in the middle of the two pins; it will then appear as shown in the last diagram.

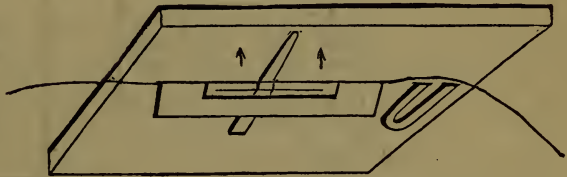

Domestic Telegraph. — Cut four pieces of bright brass, and join two by soldering with a copper wire 4 in. long, as in fig. 1. Then take the two other pieces and join them in the same manner by a copper wire 2 in. long, as in fig. 2. The wire must be soldered to one side, the two pieces to the left or to the right; solder two more wires; these wires are to go in the screw-cups of the battery. Drill a hole in the centre of each piece of brass, and countersink each hole so that the heads of the screws may be level; now screw the four pieces on a piece of dry wood, as in fig. 3. The size of the brasses should be 1 in. wide, and $1\frac{1}{2}$ in. long. After the wires to convey the electricity are put up, and the telegraph instrument is at the top of the house, and the con-

veyance wires, two in number, are attached to each end of the coil of the instrument, the two ends at the bottom are to be attached to two small handles of brass, as in fig. 4. When a message is sent, the two handles are to be made to touch the right pair of brasses, if the index is meant to turn to the right ; if wanted to turn to the left, the handles are to be

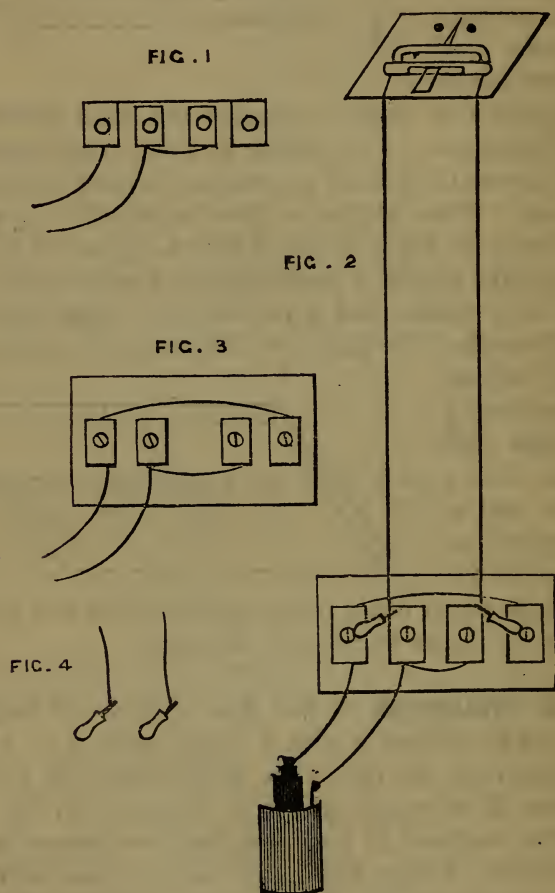

put on the left pair. Now perhaps when you put the handles on the right pair, the index will turn to the left ; you can remedy this by reversing the battery, *i.e.*, put the positive wire where the negative was, and the negative where the positive was. By the adoption of what is called a code of signals, the deflections of a single index may be made to denote all the

letters of the alphabet. The code for a single index instrument is shown in the following diagram, the number of deflections

*	A	B	C	D	E	F
	\	//	///	////	\	//
	\\	///	////	\	//	///
G	H	I	K	L	M	
\	//	\	//	\	/	
N	O	P	Q	R	S	
//	///	////	\	\	/	/
T	U	V	W	X	Y	
//	\	//	Z	\	//	//
			\	\		

of the index to the right and left being made to indicate the letters under which the marks are placed. The deflections of the symbols for each letter commence in the direction of the short marks, and end with the long ones. Thus it will be seen, that to indicate the letter D, the index is deflected to the right once, then to the left once; whilst two deflections, beginning with one to the left, and ending with one to the right, make the letter R.

THE UNIVERSITY OF CHICAGO
LIBRARY

A B C D E F
G H I K L M
N O P Q R S
T U V W X Y
Z

THE UNIVERSITY OF CHICAGO
LIBRARY

INDEX.

The entries printed in Capitals indicate that several articles relating to the subject named will be found at the reference given.

- A B C Gas meter, 264.
Æolian harp, 228.
Air-engine, 38.
Air-pumps, 39.
Alarums, 192.
Alley's drilling machine, 28.
Alloy for journal boxes, 23.
Alphabetical dial telegraph, 326.
Alum in safes, 250.
Amalgam pad, 306.
Aniline black varnish, 84.
Aniline dyes, 266.
Aquarium cementing, 81.
Aquarium, fresh-water, 240.
Aquarium fountain, 244.
Axles, hardening, 9.
- Balance, chemical, 251.
Balloons, fire, 294.
Balloons, varnishing, 85.
Bancroft's lard oil process, 255.
Band-saws, brazing, 16.
Barometer, simple, 78.
Battery, constant, 301.
Beams, cast-iron, breaking weight, 98.
Bell, electric, 311.
Bevel-wheels, 59.
Billiard balls, dyeing, 54.
Bird-stuffing, 235.
- Bisulphide of tin, 101.
Black for telescopes, &c., 74.
Black Japan varnish, 84.
Blacking, 261.
Blast engine, 106.
Bleaching ivory, 53.
Bleaching powder, 268.
Blow-pipe, 246, 247.
Blow-pipe jointing, 92.
Boats, model, steam propeller, 128.
Boilers, 105, 106, 127, 128.
Bone manure, 262.
Book marbling and sprinkling, 32, 48.
Boring, 31.
Boring cork, 3.
Boring-machine, 29.
Bowls, cutting out, 53.
Brakes, railway, 141.
Brass, bronzing, 287.
Brass, casting, 93.
Brass, lacquering, 90.
Brass, melting, 92.
Brass, pickling, 93.
Brass, silvering, 278.
Brass-soldering, 91.
Brass tubes, bending, 93.
Brazing band-saws, 16.
Brewer's pitch substitute, 88.

- Bright's electric clock, 160.
 BRONZING, 284.
 Brooch stones, cutting, 33.
 Buckles in sheet-iron, 98.

 Camera lucida, 77.
 Camera obscura, 43.
 Cameras, dead black, 74.
 Candles, Roman, 290.
 Capstan-pumps, hydraulic, 41.
 Carrier, adjusting, 24.
 Carvings, wooden, protecting, 184.
 Case hardening, 96.
 Castings, brass, 93.
 Castings, shrinkings, 101.
 CEMENTS AND GLUES, 79.
 Centre-bit, 35.
 Chemical balance, 251.
 CHEMICAL PROCESSES, &c., 246.
 Chimney cowls, 187, 188.
 Chimney lamp, 262.
 Chlorate of potash, 250.
 Chronometer escapement, 157.
 Chronometer oven, 169.
 Circle, diameter, 174.
 Cisterns, 194.
 Clarifying water, 254.
 Cleaning paint, 185.
 Cleaning pictures, 199.
 Cloak peg frame, 192.
 CLOCKMAKING, 150.
 Clocks, electro-magnetic, 160, 309.
 Closet construction, 189.
 Coal gas, bisulphide of carbon, 261.
 Collodion filter, 211.
 Colour vehicle, 88.
 Colouring maps, 198.
 Columbia metal, 29.
 Combustion of oil rags, 250.
 Composition ornaments, 186, 282.
 Composition pictures, 222.
 Condenser, Rhumkorff, 306.
 Copal varnish, 85.
 Copper, bronzing, 286.
 Copper, coating, 94.
 Copper, electro-gilding, 274.
 Copper, silvering, 278.
 Copying ink, 259.
 Cork-boring, 3.
 Cork-springs, 42.
 Cotton photographs, 223.

 Cotton waste, 36.
 Cotton, waterproofing, 270.
 Cowls, chimney, 187, 188.
 Crucibles of lime, 250.
 Curves, quickening, 5.
 Cutting glass, 175, 176.
 Cutting microscopic sections, 74.
 Cyanide of silver, 204.
 Cylinders, Geneva, 168.

 Damp on walls, 184.
 Dead-black for telescopes, &c., 74.
 Designs on glass, 177.
 Dials, sun, 171, 173.
 Diameter of circle, 174.
 Diamonds, polishing, 47.
 Distances, ascertaining, 6.
 Distances, rifle stadia, 148.
 Domestic telegraph, 329.
 Door spring, 185.
 Double photographs, 214.
 Dovetailing, 180.
 DRAWING, 197.
 Drawing camera obscura, 43.
 Drawing on glass, 177.
 Drawing spirals, 4.
 Drawing varnishes, 84, 200.
 Drilling glass, 27.
 Drilling-machines, 3, 26, 28, 30, 33.
 Drills, home made, 32.
 Drills, tempering, 9.
 Driving-straps, 47.
 Drowning: a rescue apparatus, 55.
 Dryers, 88.
 DYES, 265.
 Dyeing ivory, 54.

 Earth batteries, 303.
 Edge tools, sharpening, 9.
 ELECTRICITY, &c., 295.
 Electric bell, 311.
 Electric clock, 160, 309.
 Electric railway signal, 135.
 Electro-gilding, 273, 274.
 Electrotyping, 270.
 Enamel, opaque, 178.
 Enamel for card photographs, 212.
 Engines, garden, 195.
 Engines' powers, 112.
 Engine, rotary, 102.

- Engravings, transferring to glass, 177.
- Epicycloidal wheel, 175.
- Escapement, chronometer, 157.
- Escapement, double-roller, 159.
- Escapement, four-legged, 154.
- Escapement, verge, 150.
- Fan, fire, 11.
- Feathering float, 60.
- Feathers, ostrich, dyes, 266.
- Fictile ivory, 202.
- Files, renovating, 4.
- Filter, 190.
- FIRE-ARMS, 148.
- Fire-balloons, 294.
- Fire-fan, 11.
- Fire-proofing textile fabrics, 270.
- FIREWORKS, 289.
- Fish in plaster moulds, 202.
- Fixing photographs, 217.
- Fixing prints, 211.
- Flower-pot battery, 301.
- Flowers dried in natural colours, 239.
- Focussing screen, 217.
- Fog signals, 138.
- Fountain for aquarium, 244.
- Freezing mixtures, 219.
- French weights and measures, 1.
- French-polish, 86.
- Fret-saws, 14.
- Friction polish, 88.
- Frogs in plaster moulds, 202.
- Furnaces, smelting, 101.
- Galena and silver separation, 95.
- Galvanic battery, 317.
- Galvanometer, 311.
- Garden engine, 196, 197.
- Gas-blow-pipe, 249.
- Gas generator, 49.
- Gas, laughing, 251.
- Gas-meter, ABC, 264.
- Gas-pipes, soldering, 91.
- Gas-pipes, water in, 265.
- Geneva cylinders, 168.
- German silver, 100.
- German silver, polishing, 94.
- Giffard injector, 109.
- GILDING, 270.
- GLASS, 175.
- Glass, cementing, 80.
- Glass, drawing on, 177.
- Glass, chimney breakage, 263.
- Glass-cutting, 175, 176.
- Glass-designs, 177.
- Glass, drilling, 27.
- Glass, gilding, 274.
- Glass-globes for magnifying glasses, 218.
- Glass-plates, photographic cleaning, 213.
- Glass, soluble, 179.
- Glass, transferring on, 177.
- Glass, varnishing, 84.
- Glazers for polishing metals, 97.
- GLUES, 79.
- Gold, artificial, 95.
- Gold, dissolving, 95.
- Gold, lacquer, 89.
- Gold, mosaic, 284.
- Gold powder, 286.
- Gold size, 286.
- Governor's steam, 103, 107, 108.
- Grease, wheel, 148.
- Grinding pebbles, 33.
- Grinding lenses, 60.
- Grindstones, 12.
- Gum, postage stamp, 82.
- Gun-barrels, 149.
- Gun-barrels, bronzing, 287.
- Gun-cotton, 149.
- Gunpowder force, 149.
- Gauge for watch hands, 170.
- Gypsum, 201.
- Gyroscope, 68.
- Hair springs, reducing, 165.
- Handkerchiefs, photographic, 223.
- Hand-press, 21.
- Harness blacking, 261.
- Harp, Æolian, 228.
- Hat-peg frame, 192.
- Heights, measuring, 5.
- Hinges cutting, 56.
- HOROLOGY, 150.
- Hot-water pipes' cement, 82.
- HOUSE, 184.
- Huxley's tappet-pump, 110.
- Hydraulic capstan pumps, 41.
- Hydraulic ram, 37.

- Hydrogen lamp, 263.
 Hyposulphite of Ammonia, 207.
- Indelible pencil writing, 199.
 Indiarubber, 261, 262.
 Indiarubber cementing, 79.
 Incrustation in boilers, 105.
 Injector, Giffard, 109.
 INKS, 250.
 Inks for writing in relief on zinc, 261.
 Inlaying with mother of pearl, 96.
 Insects for cases, 237.
 Instantaneous photography, 204.
 INSTRUMENTS, MISCELLANEOUS, 3.
 Instruments, to keep from rust, 78.
 Insulation, telegraphic, 319.
 Iron, bronzing, 287.
 Iron, buckles in sheet, 98.
 Iron solders, 91.
 Iron stains, removing, 186.
 Ivory, bleaching, 53.
 Ivory, cleaning, 54.
 Ivory, dyeing, 54.
 Ivory, softening, 54.
 Ivory, fictile, 202.
- Joiners shooting boards, 184.
 Journal-boxes alloy, 23.
- Kaleidoscope, 57.
- LACQUERS, 88.
 Lamp, chimney, 262.
 Lamp, hydrogen, 263.
 Lard oil, refining, 255.
 Lathe, rose bit, 4.
 Laughing gas, 251.
 Lead ores, working, 102.
 Leakage in smoke-box, 23.
 Leather, cementing, 79.
 Leather washers, 35.
 Leaves, skeletonising, 238.
 Lenses, cleaning, 22.
 Lenses, grinding, 60.
 Lenses' magnifying power, 65.
 Life-saving apparatus, 55.
 LIGHTING, 262.
 Light, artificial, for photography, 215.
 Lime-crucible, 250.
- Lime-process in sugar extraction, 257.
 Lime-water, 256.
 Linen photographs, 223.
 Lock, magnetic, 19.
 LOCOMOTIVES, 130.
 Lubricant, 250.
- Machines, boring, 29.
 Machines, drilling, 26, 27, 28, 30.
 Magic lantern photography, 220.
 Magnesium light, 215.
 MAGNETISM, 296.
 Magnetic Lock, 19.
 Mainsprings strength, 166.
 Manure, bone, 262.
 Map-colouring, 198.
 Marble imitating, 185.
 Marble, to remove stains, 188.
 Marbling books, 48.
 Marine propulsion, 60, 65.
 Matches without phosphorus, 249.
 Measures, French, 1.
 Measuring distances, 6.
 Measuring heights, 5.
 Meek's watch hand gauge, 170.
 Mercurial pendulum, 163.
 Mercury, extracting, 100.
 METALS AND METAL-WORKING, 92.
 Metals, cementing, 80.
 Metal glazers, 97.
 Metals, mixed, 99.
 Metric system, 1.
 Micagraphy, 178.
 Microscope hints, 76.
 Microscope, wood sections, 74.
 Mirrors, silvering, 276, 278.
 MODELLING, 200.
 Mosaic gold, 284.
 Mother of pearl, inlaying, 96.
 Mortar, waterproof, 184.
 Moulding plaster, 202.
 Moulding small objects, 202.
 Moulding, to prevent sand sticking, 100.
 Music, Æolian harp, 228.
 Music, violins, 230.
- Nails, French and English, wire hand, 26.
 Needle, magnetised, 314.

- Negatives, reproducing, 222.
 Nitrate of potash, 253.
 Nitrate of silver, 209.
 Norton's well-pump, 45.

 Oil for watches, 171.
 Olive oil, refining, 254.
 Omnibus register, 50.
 Organ pipes, gilding, 283.
 Ornaments, composition for, 186.
 Ostrich feather dyes, 266.
 Oxychloride of zinc, 102.

 Paint, cleaning, 185.
 Painters' cream, 201.
 Painting on glass, 177, 178.
 Paintings, varnishing, 84.
 Paper bronzing, 289.
 Paper varnishing, 85.
 Paper for transfers, 197.
 Paper for tracing, 198.
 Papiér-maché, 49.
 Paraffin waterproofing, 268.
 Parchment cleaning, 56.
 Parkes' plastic moulding, 202.
 Pebbles, grinding and polishing, 33.
 Peet's safety-valve, 117.
 Pencil drawings, preserving, 199.
 Pencil writing, indelible, 199.
 Pendulum, compensating, 157.
 Pendulum, mercurial, 163.
 Peroxide of nitrogen, 215.
 Perpetual motion, electric clock, 160.
 Petroleum stove, 255.
 Pewter, 99.
 Pharaoh's serpent, 295.
 PHOTOGRAPHY, 203.
 Photographometer, 206.
 Picture-cleaning, 199.
 Picture frames, gilding, 279.
 Picture frames, making, 281.
 Picture frames, in compo., ornaments, 282.
 Picture frames, staining, 279.
 Pillar drilling-machine, 30.
 Pin, new style, 25.
 Pinion and rack, 174.
 Plant preserving, 258.
 Plaster of Paris, 201.
 Plaster casts, bronzing, 284.
 Plaster casts, varnishing, 203.

 Plate cleaning, 95.
 Plate soldering, 91.
 Plateholder, photographic, 220.
 Plating, 280.
 Plating skeleton leaves, 239.
 Plumbers' solder, 91.
 Polariscopes, 77.
 Polish, French, 86.
 Polish, friction, 88.
 Polishing diamonds, 47.
 Polishing pebbles, 33.
 Porcelain cementing, 81.
 Postage-stamp gum, 82.
 Potash, chlorate, 250.
 Potash, nitrate, 253.
 Power of engines, 112.
 Preserving plants, 238.
 Preserving skins, 234.
 Prince Rupert's drops, 257.
 Printed cottons, washing, 268.
 Printers' ink, 258.
 Printing photographs, 214.
 Prints, fixing, 211.
 Prints, varnishing, 200.
 PROCESSES, MISCELLANEOUS, 3.
 Pumps, air, 39.
 Pump, tappet, 110.
 Pump, deep well, 43.
 Putty for steam joints, 83.
 PYROTECHNY, 289.

 Quickening curves, 5.

 Radii-drawing to inaccessible centres, 48.
 Rags oily combustion, 250.
 RAILWAYS AND LOCOMOTIVES, 130.
 Rain-water, storing, 195.
 Ram, hydraulic, 37.
 Ratchet wheels, 52.
 Registering machine for 'buses, 52.
 Retouching photographs, 221.
 Reversing motion in engines, 125.
 Rhumkorff condenser, 306.
 Rick cloths, waterproofing, 270.
 Rifle stadia for distances, 148.
 Rock-drilling, 27.
 Rockets, 291, 292, 293.
 Roman candles, 290.
 Rose-bit for lathe, 4.
 Rotary engine, 102.

- Rotating magnet, 313.
 Rupert drops, 25.
 Rust on instruments, 78.

 Sackholder, 46.
 Safes, alum in, 250.
 Safety-valves, 112, 117, 118, 120, 121.
 Saw benches, 13.
 Sawing machine, 18.
 Saws, band, brazing, 16.
 Saws, fret, 14.
 Screw-driver, 20.
 Screw-propeller, 67.
 Sealing wax, 256.
 Semaphores, 131.
 Sharpening edge tools, 9.
 Shooting boards for joiners, 184.
 Shrinkings of castings, 101.
 Siemens and Halske's insulator, 321.
 Signals, fog, 138.
 Signals, railway, 130, 135, 139.
 Silk, blue, dye, 265, 266.
 Silk photographs, 211.
 Silver cyanide, 204.
 Silver dial cleaning, 168.
 Silver in photography, 207, 208, 209.
 Silver, hardness, 94.
 Silver, separating from galena, 95.
 Silver, soldering, 91.
 Silver, German, 100.
 Silvering, brass, 278.
 Silvering, copper, 178.
 Silvering, imitation, 283.
 Silvering globes, &c., 276.
 Silvering mirrors, 278.
 Skates, wheeled, 50.
 Skeleton leaves, 238.
 Skins, preserving, 234.
 Slide-valve, 119, 122, 126.
 Smelting furnace, 101.
 Smoke-box leakage, 23.
 Smoky chimney, cowl for, 188.
 SOLDERS AND SOLDERING, 90.
 Soluble glass, 179.
 Speculum metal, 100.
 Spirals, 4, 5.
 Spirit blow-pipes, 246, 247.
 Spring for doors, 185.

 Springs, cork, 42.
 Sprinkling book-edges, 32.
 Stains of nitrate of silver, 217.
 Stains on marble, to remove, 188.
 Staining wood, 182.
 STEAM ENGINE, 102.
 Steam-joints, cementing, 82.
 Steam-pipes, cementing, 82.
 Steam-propeller for model boats, 128.
 Steel, bronzing, 287.
 Steel, gilding, 273.
 Steel, polished, preserving, 97.
 Steel, soldering, 91.
 Steel surfaces, preservation, 98.
 Steel, tempering, 10.
 Steel welding composition, 96.
 Stencil-plates, 198.
 Stereotyping, paper process, 25.
 Stone cementing, 80.
 Straps, driving, 47.
 Straw, to colour black, 267.
 Stud-box and wrench, 23.
 Studio photographic design, 224.
 Stuffing birds, 234.
 Sugar extraction, lime process, 257.
 Sulphate of iron preservation, 99.
 Sun-dial, 171, 173.
 Superheater and safety valve, 118.
 Swann's safety valve, 113.
 Syphon, 38.

 T-square, protracting, 10.
 Tappet-pump, 110.
 Taps, tempering, 9.
 TAXIDERMY, 234.
 TELEGRAPHY, 314.
 Telescopes, dead black, 74.
 Telescopes' stand, 73.
 Telescopes, making, 71.
 Tempera, 186.
 Tempering drills and taps, 9.
 Tempering steel, 10.
 Tent, photographic, 227, 228.
 Textile fabrics, fireproof, 270.
 Tin bisulphide, 101.
 Tin lacquer, 89.
 Tinning, 101.
 Tinware, solder, 91.
 Tissue-paper, oiling, 198.
 Titanium, German, 99.

- Titanium, Spanish, 99.
 TOOLS, MISCELLANEOUS, 3.
 Tools, hardening and tempering,
 II.
 Tools, sharpening, 9.
 Tortoiseshell, polishing, 56.
 Tracing-paper, 198.
 Tracings, cement, 80.
 Tramway locomotives, 146.
 Transferring on glass, 177.
 Transfer paper, 197.
 Tube-well pump, 44.
 Type metal, 99.

 Valves, safety, 112.
 Valve, slide, 122.
 VARNISHES, 83.
 Varnishes for photographs, 216.
 Varnishes for prints and drawings,
 200.
 Varnishing plaster casts, 203.
 Vegetables in plaster moulds, 202.
 Vellum cleaning, 55.
 Vehicle for colour, 88.
 Ventilation, 190.
 Verge escapements, 150.
 Vibration, musical, 234.
 Vinegar, anti-pestilential, 186.
 Violins, home-made, 230.
 Violin tools, 231.
 Violins, varnishing, 87.
 Vulcanised india-rubber, 262.

 Walls, damp, 184.
 Walls in tempera, 186.
 Washers, leather, 35.
 Washing printed cottons, 268.

 Waste cotton, 36.
 WATCHMAKING, 150.
 Water, clarifying, impure, 254.
 Water storing, 195.
 Waterproof enamel for photographs,
 212.
 Waterproof mortar, 184.
 WATERPROOFING, 268.
 Water-wheel, 36.
 Weapons, hardening and tempering,
 II.
 Weather-glass, 78.
 WEIGHTS AND MEASURES, I.
 Welding composition for steel, 96.
 Well-pumps, 43, 44.
 Wheeled skates, 50.
 Wheel, epicycloidal, 175.
 Wheel, feathering float, 60.
 Wheel grease, 148.
 Wheels, bevel, 59.
 White metal, 96, 99.
 Wood, bronzing, 288.
 Wood carvings, protecting, 184.
 Wood cementing, 80.
 Wood microscopic sections, 74.
 Woodstaining, 182.
 Woods, strength of, 179.
 Wood, varnishing, 86.
 Wood, washed, 179.
 Woodbury process, 214.
 Woollens' dyes, 266.
 Wrench, 23.
 Writing in pencil indelible, 199.

 Zinc, oxychloride, 102.
 Zinc perforated, varnishing, 86.
 Zinc, writing in, 261.

SCIENTIFIC BOOKS

PUBLISHED BY

D. VAN NOSTRAND,

23 MURRAY STREET & 27 WARREN STREET,

NEW YORK.

Weisbach's Mechanics.

New and Revised Edition.

8vo. Cloth. \$10.00.

A MANUAL OF THE MECHANICS OF ENGINEERING, and of the Construction of Machines. By JULIUS WEISBACH, PH. D. Translated from the fourth augmented and improved German edition, by ECKLEY B. COXE, A.M., Mining Engineer. Vol. I.—Theoretical Mechanics. 1,100 pages, and 902 wood-cut illustrations.

ABSTRACT OF CONTENTS.—Introduction to the Calculus—The General Principles of Mechanics—Phoronomics, or the Purely Mathematical Theory of Motion—Mechanics, or the General Physical Theory of Motion—Statics of Rigid Bodies—The Application of Statics to Elasticity and Strength—Dynamics of Rigid Bodies—Statics of Fluids—Dynamics of Fluids—The Theory of Oscillation, etc.

“The present edition is an entirely new work, greatly extended and very much improved. It forms a text-book which must find its way into the hands, not only of every student, but of every engineer who desires to refresh his memory or acquire clear ideas on doubtful points.”—*Manufacturer and Builder.*

“We hope the day is not far distant when a thorough course of study and education as such shall be demanded of the practising engineer, and with this view we are glad to welcome this translation to our tongue and shores of one of the most able of the educators of Europe.”—*The Technologist.*

Francis' Lowell Hydraulics.

Third Edition.

4to. Cloth. \$15.00.

LOWELL HYDRAULIC EXPERIMENTS — being a Selection from Experiments on Hydraulic Motors, on the Flow of Water over Weirs, and in Open Canals of Uniform Rectangular Section, made at Lowell, Mass. By J. B. FRANCIS, Civil Engineer. Third edition, revised and enlarged, including many New Experiments on Gauging Water in Open Canals, and on the Flow through Submerged Orifices and Diverging Tubes. With 23 copperplates, beautifully engraved, and about 100 new pages of text.

The work is divided into parts. PART I., on hydraulic motors, includes ninety-two experiments on an improved Fourneyron Turbine Water-Wheel, of about two hundred horse-power, with rules and tables for the construction of similar motors; thirteen experiments on a model of a centre-vent water-wheel of the most simple design, and thirty-nine experiments on a centre-vent water-wheel of about two hundred and thirty horse-power.

PART II. includes seventy-four experiments made for the purpose of determining the form of the formula for computing the flow of water over weirs; nine experiments on the effect of back-water on the flow over weirs; eighty-eight experiments made for the purpose of determining the formula for computing the flow over weirs of regular or standard forms, with several tables of comparisons of the new formula with the results obtained by former experimenters; five experiments on the flow over a dam in which the crest was of the same form as that built by the Essex Company across the Merrimack River at Lawrence, Massachusetts; twenty-one experiments on the effect of observing the depths of water on a weir at different distances from the weir; an extensive series of experiments made for the purpose of determining rules for gauging streams of water in open canals, with tables for facilitating the same; and one hundred and one experiments on the discharge of water through submerged orifices and diverging tubes, the whole being fully illustrated by twenty-three double plates engraved on copper.

In 1855 the proprietors of the Locks and Canals on Merrimack River consented to the publication of the first edition of this work, which contained a selection of the most important hydraulic experiments made at Lowell up to that time. In this edition the principal hydraulic experiments made there, subsequent to 1855, have been added, including the important series above mentioned, for determining rules for the gauging the flow of water in open canals, and the interesting series on the flow through a submerged Venturi's tube, in which a larger flow was obtained than any we find recorded.

Williamson's Meteorological Tables.

4to. Flexible Cloth. \$2.50.

PRACTICAL TABLES IN METEOROLOGY AND HYPSONOMETRY, in connection with the use of the Barometer. By Col. R. S. WILLIAMSON, U. S. A.

Merrill's Iron Truss Bridges.

Third Edition.

4to. Cloth. \$5.00.

IRON TRUSS BRIDGES FOR RAILROADS. The Method of Calculating Strains in Trusses, with a careful comparison of the most prominent Trusses, in reference to economy in combination, etc., etc. By Brevet Colonel WILLIAM E. MERRILL, U.S.A., Major Corps of Engineers. Nine lithographed plates of illustrations.

"The work before us is an attempt to give a basis for sound reform in this feature of railroad engineering, by throwing 'additional light upon the method of calculating the maxima strains that can come upon any part of a bridge truss, and upon the manner of proportioning each part, so that it shall be as strong relatively to its own strains as any other part, and so that the entire bridge may be strong enough to sustain several times as great strains as the greatest that can come upon it in actual use.'"—*Scientific American*.

"The author has presented his views in a clear and intelligent manner, and the ingenuity displayed in coloring the figures so as to present certain facts to the eye forms no inappreciable part of the merits of the work. The reduction of the 'formulae for obtaining the strength, volume, and weight of a cast-iron pillar under a strain of compression,' will be very acceptable to those who have occasion hereafter to make investigations involving these conditions. As a whole, the work has been well done."—*Railroad Gazette, Chicago*.

Allan's Theory of Arches.

18mo. Boards. 50 cts.

THEORY OF ARCHES. By Prof. W. ALLAN, formerly of Washington and Lee University. Illustrated.

"This little volume is an amplification and explanation of Prof. Rankine's chapters on this subject."

Shreve on Bridges and Roofs.

8vo, 87-wood-cut illustrations. Cloth. \$5.00.

A TREATISE ON THE STRENGTH OF BRIDGES AND ROOFS—comprising the determination of Algebraic formulas for Strains in Horizontal, Inclined or Rafter, Triangular, Bow-string, Lenticular and other Trusses, from fixed and moving loads, with practical applications and examples, for the use of Students and Engineers. By SAMUEL H. SHREVE, A.M., Civil Engineer.

“On the whole, Mr. Shreve has produced a book which is the simplest, clearest, and at the same time, the most systematic and with the best mathematical reasoning of any work upon the same subject in the language.”—*Railroad Gazette*.

“From the unusually clear language in which Mr. Shreve has given every statement, the student will have but himself to blame if he does not become thorough master of the subject.”—*London Mining Journal*.

“Mr. Shreve has produced a work that must always take high rank as a text-book, * * * and no Bridge Engineer should be without it, as a valuable work of reference, and one that will frequently assist him out of difficulties.”—*Franklin Institute Journal*.

The Kansas City Bridge.

4to. Cloth. \$6.00

WITH AN ACCOUNT OF THE REGIMEN OF THE MISSOURI RIVER, and a description of the Methods used for Founding in that River. By O. CHANUTE, Chief Engineer, and GEORGE MORISON, Assistant Engineer. Illustrated with five lithographic views and twelve plates of plans.

Illustrations.

VIEWS.—View of the Kansas City Bridge, August 2, 1869. Lowering Caisson No. 1 into position. Caisson for Pier No. 4 brought into position. View of Foundation Works, Pier No. 4. Pier No. 1.

PLATES.—I. Map showing location of Bridge. II. Water Record—Cross Section of River—Profile of Crossing—Pontoon Protection. III. Water Deadend—Caisson No. 2—Founda-

tion Works, Pier No. 3. IV. Foundation Works, Pier No. 4. V. Foundation Works, Pier No. 4. VI. Caisson No. 5—Sheet Piling at Pier No. 6—Details of Dredges—Pile Shoe—Beton Box. VII. Masonry—Draw Protection—False Works between Piers 3 and 4. VIII. Floating Derricks. IX. General Elevation—176 feet span. X. 248 feet span. XI. Plans of Draw. XII. Strain Diagrams.

Clarke's Quincy Bridge.

4to. Cloth. \$7.50.

DESCRIPTION OF THE IRON RAILWAY Bridge across the Mississippi River at Quincy, Illinois. By THOMAS CURTIS CLARKE, Chief Engineer. Illustrated with twenty-one lithographed plans.

Illustrations.

PLATES.—General Plan of Mississippi River at Quincy, showing location of Bridge. IIa. General Sections of Mississippi River at Quincy, showing location of Bridge. IIb. General Sections of Mississippi River at Quincy, showing location of Bridge. III. General Sections of Mississippi River at Quincy, showing location of Bridge. IV. Plans of Masonry. V. Diagram of Spans, showing the Dimensions, Arrangement of Panels, etc. VI. Two hundred and fifty feet span, and details. VII. Three hundred and sixty feet Pivot Draw. VIII. Details of three hundred and sixty feet Draw. IX. Ice-Breakers, Foundations of Piers and Abutments, Water Table, and

Curve of Deflections. X. Foundations of Pier 2, in Process of Construction. XI. Foundations of Pier 3, and its Protection. XII. Foundations of Pier 3, in Process of Construction, and Steam Dredge. XIII. Foundations of Piers 5 to 18, in Process of Construction. XIV. False Works, showing Process of Handling and Setting Stone. XV. False Works for Raising Iron Work of Superstructure. XVI. Steam Dredge used in Foundations 9 to 18. XVII. Single Bucket Dredge used in Foundations of Bay Piers. XVIII. Saws used for Cutting Piles under water. XIX. Sand Pump and Concrete Box. XX. Masonry Travelling Crane.

Whipple on Bridge Building.

8vo, Illustrated. Cloth. \$4.00.

AN ELEMENTARY AND PRACTICAL TREATISE ON BRIDGE BUILDING. An enlarged and improved edition of the Author's original work. By S. WHIPPLE, C. E., Inventor of the Whipple Bridges, &c. Second Edition.

The design has been to develop from Fundamental Principles a system easy of comprehension, and such as to enable the attentive reader and student to judge understandingly for himself, as to the relative merits of different plans and combinations, and to adopt for use such as may be most suitable for the cases he may have to deal with.

It is hoped the work may prove an appropriate Text-Book upon the subject treated of, for the Engineering Student, and a useful manual for the Practising Engineer and Bridge Builder.

Stoney on Strains.

New and Revised Edition, with numerous illustrations.

Royal 8vo, 664 pp. Cloth. \$12.50.

THE THEORY OF STRAINS IN GIRDERS and Similar Structures, with Observations on the Application of Theory to Practice, and Tables of Strength and other Properties of Materials. By BINDON B. STONEY, B. A.

Roebling's Bridges.

Imperial folio. Cloth. \$25.00.

LONG AND SHORT SPAN RAILWAY BRIDGES. By JOHN A. ROEBLING, C. E. Illustrated with large copperplate engravings of plans and views.

List of Plates

1. Parabolic Truss Railway Bridge. 2, 3, 4, 5, 6. Details of Parabolic Truss, with centre span 500 feet in the clear. 7. Plan and View of a Bridge over the Mississippi River, at St. Louis, for railway and common travel. 8, 9, 10, 11, 12. Details and View of St. Louis Bridge. 13. Railroad Bridge over the Ohio.

Diedrichs' Theory of Strains.

8vo. Cloth. \$5.00.

A Compendium for the Calculation and Construction of Bridges, Roofs, and Cranes, with the Application of Trigonometrical Notes. Containing the most comprehensive information in regard to the Resulting Strains for a permanent Load, as also for a combined (Permanent and Rolling) Load. In two sections adapted to the requirements of the present time. By JOHN DIEDRICHS. Illustrated by numerous plates and diagrams.

"The want of a compact, universal and popular treatise on the Construction of Roofs and Bridges—especially one treating of the influence of a variable load—and the unsatisfactory essays of different authors on the subject, induced me to prepare this work."

Jacob on Retaining Walls.

18mo. Boards. 50 cts.

PRACTICAL DESIGNING OF RETAINING WALLS. By
ARTHUR JACOB, A. B.

Campin on Iron Roofs.

Large 8vo. Cloth. \$2.00.

ON THE CONSTRUCTION OF IRON ROOFS. A Theoretical and Practical Treatise. By FRANCIS CAMPIN. With wood-cuts and plates of Roofs lately executed.

“The mathematical formulas are of an elementary kind, and the process admits of an easy extension so as to embrace the prominent varieties of iron truss bridges. The treatise, though of a practical scientific character, may be easily mastered by any one familiar with elementary mechanics and plane trigonometry.”

Holley's Railway Practice.

1 vol. folio. Cloth. \$12.00.

AMERICAN AND EUROPEAN RAILWAY PRACTICE, in the Economical Generation of Steam, including the materials and construction of Coal-burning Boilers, Combustion, the Variable Blast, Vaporization, Circulation, Super-heating, Supplying and Heating Feed-water, &c., and the adaptation of Wood and Coke-burning Engines to Coal-burning; and in Permanent Way, including Road-bed, Sleepers, Rails, Joint Fastenings, Street Railways, &c., &c. By ALEXANDER L. HOLLEY, B. P. With 77 lithographed plates.

“This is an elaborate treatise by one of our ablest civil engineers, on the construction and use of locomotives, with a few chapters on the building of Railroads. * * * All these subjects are treated by the author, who is a first-class railroad engineer, in both an intelligent and intelligible manner. The facts and ideas are well arranged, and presented in a clear and simple style, accompanied by beautiful engravings, and we presume the work will be regarded as indispensable by all who are interested in a knowledge of the construction of railroads and rolling stock, or the working of locomotives.”—*Scientific American*.

Henrici's Skeleton Structures.

8vo. Cloth. \$1.50.

SKELETON STRUCTURES, especially in their Application to the building of Steel and Iron Bridges. By OLAUS HENRICI. With folding plates and diagrams.

By presenting these general examinations on Skeleton Structures, with particular application for Suspended Bridges, to Engineers, I venture to express the hope that they will receive these theoretical results with some confidence, even although an opportunity is wanting to compare them with practical results.

O. H.

Useful Information for Railway Men.

Pocket form. Morocco, gilt, \$2.00.

Compiled by W. G. HAMILTON, Engineer. Sixth edition, revised and enlarged. 570 pages.

"It embodies many valuable formulæ and recipes useful for railway men, and, indeed, for almost every class of persons in the world. The 'information' comprises some valuable formulæ and rules for the construction of boilers and engines, masonry, properties of steel and iron, and the strength of materials generally."—*Railroad Gazette, Chicago.*

Holley's Ordnance and Armor.

493 Engravings. Half Roan, \$10.00. Half Russia, \$12.00.

A TREATISE ON ORDNANCE AND ARMOR—Embracing Descriptions, Discussions, and Professional Opinions concerning the MATERIAL, FABRICATION, Requirements, Capabilities, and Endurance of European and American Guns, for Naval, Sea Coast, and Iron-clad Warfare, and their RIFLING, PROJECTILES, and BREACH-LOADING; also, Results of Experiments against Armor, from Official Records, with an Appendix referring to Gun-Cotton, Hooped Guns, etc., etc. By ALEXANDER L. HOLLEY, B. P. 948 pages, 493 Engravings, and 147 Tables of Results, etc.

Kirkwood on Filtration.

4to. Cloth. \$15.00.

REPORT ON THE FILTRATION OF RIVER WATERS, for the Supply of Cities, as practised in Europe, made to the Board of Water Commissioners of the City of St. Louis. By JAMES P. KIRKWOOD. Illustrated by 30 double-plate engravings.

CONTENTS.—Report on Filtration—London Works, General—Chelsea Water Works and Filters—Lambeth Water Works and Filters—Southwark and Vauxhall Water Works and Filters—Grand Junction Water Works and Filters—West Middlesex Water Works and Filters—New River Water Works and Filters—East London Water Works and Filters—Leicester Water Works and Filters—York Water Works and Filters—Liverpool Water Works and Filters—Edinburgh Water Works and Filters—Dublin Water Works and Filters—Perth Water Works and Filtering Gallery—Berlin Water Works and Filters—Hamburg Water Works and Reservoirs—Altona Water Works and Filters—Tours Water Works and Filtering Canal—Angers Water Works and Filtering Galleries—Nantes Water Works and Filters—Lyons Water Works and Filtering Galleries—Toulouse Water Works and Filtering Galleries—Marseilles Water Works and Filters—Genoa Water Works and Filtering Galleries—Leghorn Water Works and Cisterns—Wakefield Water Works and Filters—Appendix.

Tunner on Roll-Turning.

1 vol. 8vo. and 1 vol. plates. \$10.00.

A TREATISE ON ROLL-TURNING FOR THE MANUFACTURE OF IRON. By PETER TUNNER. Translated and adapted. By JOHN B. PEARSE, of the Pennsylvania Steel Works. With numerous wood-cuts, 8vo., together with a folio atlas of 10 lithographed plates of Rolls, Measurements, &c.

“We commend this book as a clear, elaborate, and practical treatise upon the department of iron manufacturing operations to which it is devoted. The writer states in his preface, that for twenty-five years he has felt the necessity of such a work, and has evidently brought to its preparation the fruits of experience, a painstaking regard for accuracy of statement, and a desire to furnish information in a style readily understood. The book should be in the hands of every one interested, either in the general practice of mechanical engineering, or the special branch of manufacturing operations to which the work relates.”—*American Artisan*.

Jacob on Storage Reservoirs.

18mo. Boards 50 cts.

THE DESIGNING AND CONSTRUCTION OF STORAGE RESERVOIRS. By ARTHUR JACOB, B. A. With tables and wood-cuts representing sections, etc.

Hewson on Embankments.

8vo. Cloth. \$2.00.

PRINCIPLES AND PRACTICE OF EMBANKING LANDS from River Floods, as applied to the Levees of the Mississippi. By WILLIAM HEWSON, Civil Engineer.

“This is a valuable treatise on the principles and practice of embanking lands from river floods, as applied to the Levees of the Mississippi, by a highly intelligent and experienced engineer. The author says it is a first attempt to reduce to order and to rule the design, execution, and measurement of the Levees of the Mississippi. It is a most useful and needed contribution to scientific literature.—*Philadelphia Evening Journal*.”

Grüner on Steel.

8vo. Cloth. \$3.50.

THE MANUFACTURE OF STEEL. By M. L. GRÜNER, translated from the French. By Lenox Smith, A. M., E. M., with an appendix on the Bessemer Process in the United States, by the translator. Illustrated by lithographed drawings and wood-cuts.

“The purpose of the work is to present a careful, elaborate, and at the same time practical examination into the physical properties of steel, as well as a description of the new processes and mechanical appliances for its manufacture. The information which it contains, gathered from many trustworthy sources, will be found of much value to the American steel manufacturer, who may thus acquaint himself with the results of careful and elaborate experiments in other countries, and better prepare himself for successful competition in this important industry with foreign makers. The fact that this volume is from the pen of one of the ablest metallurgists of the present day, cannot fail, we think, to secure for it a favorable consideration.—*Iron Age*.”

Bauerman on Iron.

12mo. Cloth. \$2.00.

TREATISE ON THE METALLURGY OF IRON. Containing outlines of the History of Iron Manufacture, methods of Assay, and analysis of Iron Ores, processes of manufacture of Iron and Steel, etc., etc. By H. BAUERMAN. First American edition. Revised and enlarged, with an appendix on the Martin Process for making Steel, from the report of Abram S. Hewitt. Illustrated with numerous wood engravings.

“This is an important addition to the stock of technical works published in this country. It embodies the latest facts, discoveries, and processes connected with the manufacture of iron and steel, and should be in the hands of every person interested in the subject, as well as in all technical and scientific libraries.”—*Scientific American*.

Link and Valve Motions, by W. S. Auchincloss.

Sixth Edition. 8vo. Cloth. \$3.00.

APPLICATION OF THE SLIDE VALVE and Link Motion to Stationary, Portable, Locomotive and Marine Engines, with new and simple methods for proportioning the parts. By WILLIAM S. AUCHINCLOSS, Civil and Mechanical Engineer. Designed as a hand-book for Mechanical Engineers, Master Mechanics, Draughtsmen and Students of Steam Engineering. All dimensions of the valve are found with the greatest ease by means of a Printed Scale, and proportions of the link determined *without* the assistance of a model. Illustrated by 37 wood-cuts and 21 lithographic plates, together with a copperplate engraving of the Travel Scale.

All the matters we have mentioned are treated with a clearness and absence of unnecessary verbiage which renders the work a peculiarly valuable one. The Travel Scale only requires to be known to be appreciated. Mr. A. writes so ably on his subject, we wish he had written more. *London Engineering*.

We have never opened a work relating to steam which seemed to us better calculated to give an intelligent mind a clear understanding of the department it discusses.—*Scientific American*.

Slide Valve by Eccentrics, by Prof. C. W. MacCord.

4to. Illustrated. Cloth, \$4.00.

A PRACTICAL TREATISE ON THE SLIDE VALVE BY ECCENTRICS, examining by methods, the action of the Eccentric upon the Slide Valve, and explaining the practical processes of laying out the movements, adapting the valve for its various duties in the steam-engine. For the use of Engineers, Draughtsmen, Machinists, and Students of valve motions in general. By C. W. MACCORD, A. M., Professor of Mechanical Drawing, Stevens' Institute of Technology, Hoboken, N J.

Stillman's Steam-Engine Indicator.

12mo. Cloth. \$1.00.

THE STEAM-ENGINE INDICATOR, and the Improved Manometer Steam and Vacuum Gauges; their utility and application By PAUL STILLMAN. New edition.

Bacon's Steam-Engine Indicator.

12mo. Cloth. \$1.00. Mor. \$1.50.

A TREATISE ON THE RICHARDS STEAM-ENGINE INDICATOR, with directions for its use. By CHARLES T. PORTER. Revised, with notes and large additions as developed by American Practice, with an Appendix containing useful formulæ and rules for Engineers. By F. W. BACON, M. E., Member of the American Society of Civil Engineers. Illustrated. Second Edition

In this work, Mr. Porter's book has been taken as the basis, but Mr. Bacon has adapted it to American Practice, and has conferred a great boon on American Engineers.—*Artisan*.

Steam Boiler Explosions.

18mo. Boards. 50 cts.

STEAM BOILER EXPLOSIONS. By ZERAH COLBURN.

"It is full of practical information, and serves to show in a most marked manner how very little one's knowledge upon the subject has advanced during the past ten years."—*N. Y. Times*.

Gillmore's Limes and Cements.

Fifth Edition. Revised and Enlarged.

8vo. Cloth. \$4.00.

PRACTICAL TREATISE ON LIMES, HYDRAULIC CEMENTS, AND MORTARS. Papers on Practical Engineering, U. S. Engineer Department, No. 9, containing Reports of numerous experiments conducted in New York City, during the years 1858 to 1861, inclusive. By Q. A. GILLMORE, Lt.-Col. U. S. Corps of Engineers, Brevet Major-General U. S. Army. With numerous illustrations.

“This work contains a record of certain experiments and researches made under the authority of the Engineer Bureau of the War Department from 1858 to 1861, upon the various hydraulic cements of the United States, and the materials for their manufacture. The experiments were carefully made, and are well reported and compiled.”—*Journal Franklin Institute.*

Gillmore's Coignet Beton.

8vo. Cloth. \$2.50.

COIGNET BETON AND OTHER ARTIFICIAL STONE. By Q. A. GILLMORE, Lt.-Col. U. S. Corps of Engineers, Brevet Major-General U. S. Army. 9 Plates, Views, etc.

This work describes with considerable minuteness of detail the several kinds of artificial stone in most general use in Europe and now beginning to be introduced in the United States, discusses their properties, relative merits, and cost, and describes the materials of which they are composed. . . . The subject is one of special and growing interest, and we commend the work, embodying as it does the matured opinions of an experienced engineer and expert.

Gillmore on Roads.

12mo. Cloth. In Press.

A PRACTICAL TREATISE ON THE CONSTRUCTION OF ROADS, STREETS, AND PAVEMENTS. By Q. A. GILLMORE, Lt.-Col. U. S. Corps of Engineers, Brevet Major-

Williamson on the Barometer.

4to. Cloth. \$15.00.

ON THE USE OF THE BAROMETER ON SURVEYS AND RECONNAISSANCES. Part I. Meteorology in its Connection with Hypsometry. Part II. Barometric Hypsometry. By R. S. WILLIAMSON, Bvt. Lieut.-Col. U. S. A., Major Corps of Engineers. With Illustrative Tables and Engravings. Paper No. 15, Professional Papers, Corps of Engineers.

“SAN FRANCISCO, CAL., *Feb. 27, 1867.*”

“Gen. A. A. HUMPHREYS, Chief of Engineers, U. S. Army :

“GENERAL,—I have the honor to submit to you, in the following pages, the results of my investigations in meteorology and hypsometry, made with the view of ascertaining how far the barometer can be used as a reliable instrument for determining altitudes on extended lines of survey and reconnaissances. These investigations have occupied the leisure permitted me from my professional duties during the last ten years, and I hope the results will be deemed of sufficient value to have a place assigned them among the printed professional papers of the United States Corps of Engineers.

“Very respectfully, your obedient servant,

“R. S. WILLIAMSON,

“Bvt. Lt.-Col. U. S. A., Major Corps of U. S. Engineers.”

Von Cotta's Ore Deposits.

8vo. Cloth. \$4.00.

TREATISE ON ORE DEPOSITS. By BERNHARD VON COTTA, Professor of Geology in the Royal School of Mines, Freiberg, Saxony. Translated from the second German edition, by FREDERICK PRIME, Jr., Mining Engineer, and revised by the author, with numerous illustrations.

“Prof. Von Cotta of the Freiberg School of Mines, is the author of the best modern treatise on ore deposits, and we are heartily glad that this admirable work has been translated and published in this country. The translator, Mr. Frederick Prime, Jr., a graduate of Freiberg, has had in his work the great advantage of a revision by the author himself, who declares in a prefatory note that this may be considered as a new edition (the third) of his own book.

“It is a timely and welcome contribution to the literature of mining in this country, and we are grateful to the translator for his enterprise and good judgment in undertaking its preparation; while we recognize with equal cordiality the liberality of the author in granting both permission and assistance.”—*Extract from Review in Engineering and Mining Journal.*

Plattner's Blow-Pipe Analysis.

Second edition. Revised. 8vo. Cloth. \$7.50.

PLATTNER'S MANUAL OF QUALITATIVE AND QUANTITATIVE ANALYSIS WITH THE BLOW-PIPE. From the last German edition Revised and enlarged. By Prof. TH. RICHTER, of the Royal Saxon Mining Academy. Translated by Prof. H. B. CORNWALL, Assistant in the Columbia School of Mines, New York; assisted by JOHN H. CASWELL. Illustrated with eighty-seven wood-cuts and one Lithographic Plate. 560 pages.

"Plattner's celebrated work has long been recognized as the only complete book on Blow-Pipe Analysis. The fourth German edition, edited by Prof. Richter, fully sustains the reputation which the earlier editions acquired during the lifetime of the author, and it is a source of great satisfaction to us to know that Prof. Richter has co-operated with the translator in issuing the American edition of the work, which is in fact a fifth edition of the original work, being far more complete than the last German edition."—*Silliman's Journal*.

There is nothing so complete to be found in the English language. Plattner's book is not a mere pocket edition; it is intended as a comprehensive guide to all that is at present known on the blow-pipe, and as such is really indispensable to teachers and advanced pupils.

"Mr. Cornwall's edition is something more than a translation, as it contains many corrections, emendations and additions not to be found in the original. It is a decided improvement on the work in its German dress."—*Journal of Applied Chemistry*.

Egleston's Mineralogy.

8vo. Illustrated with 34 Lithographic Plates. Cloth. \$4.50.

LECTURES ON DESCRIPTIVE MINERALOGY, Delivered at the School of Mines, Columbia College. BY PROFESSOR T. EGLESTON.

These lectures are what their title indicates, the lectures on Mineralogy delivered at the School of Mines of Columbia College. They have been printed for the students, in order that more time might be given to the various methods of examining and determining minerals. The second part has only been printed. The first part, comprising crystallography and physical mineralogy, will be printed at some future time.

Pynchon's Chemical Physics.

New Edition. Revised and Enlarged.

Crown 8vo. Cloth. \$3.00.

INTRODUCTION TO CHEMICAL PHYSICS, Designed for the Use of Academies, Colleges, and High Schools. Illustrated with numerous engravings, and containing copious experiments with directions for preparing them. By THOMAS RUGGLES PYNCHON, M.A., Professor of Chemistry and the Natural Sciences, Trinity College, Hartford.

Hitherto, no work suitable for general use, treating of all these subjects within the limits of a single volume, could be found; consequently the attention they have received has not been at all proportionate to their importance. It is believed that a book containing so much valuable information within so small a compass, cannot fail to meet with a ready sale among all intelligent persons, while Professional men, Physicians, Medical Students, Photographers, Telegraphers, Engineers, and Artisans generally, will find it specially valuable, if not nearly indispensable, as a book of reference.

"We strongly recommend this able treatise to our readers as the first work ever published on the subject free from perplexing technicalities. In style it is pure, in description graphic, and its typographical appearance is artistic. It is altogether a most excellent work."—*Eclectic Medical Journal*.

"It treats fully of Photography, Telegraphy, Steam Engines, and the various applications of Electricity. In short, it is a carefully prepared volume, abreast with the latest scientific discoveries and inventions."—*Hartford Courant*.

Plympton's Blow-Pipe Analysis.

12mo. Cloth. \$1 50.

THE BLOW-PIPE: A Guide to Its Use in the Determination of Salts and Minerals. Compiled from various sources, by GEORGE W. PLYMPTON, C.E., A.M., Professor of Physical Science in the Polytechnic Institute, Brooklyn, N. Y.

"This manual probably has no superior in the English language as a text-book for beginners, or as a guide to the student working without a teacher. To the latter many illustrations of the utensils and apparatus required in using the blow-pipe, as well as the fully illustrated description of the blow-pipe flame, will be especially serviceable."—*New York Teacher*.

Ure's Dictionary.

Sixth Edition.

London, 1872.

3 vols. Half Russia, \$32.50.

DICTIONARY OF ARTS, MANUFACTURES, AND MINES.

By ANDREW URE, M.D. Sixth edition. Edited by ROBERT HUNT, F.R.S., greatly enlarged and rewritten.

Gases in Coal Mines.

18mo. Boards. 50 cts.

A PRACTICAL TREATISE ON THE GASES MET WITH IN COAL MINES. By the late J. J. ATKINSON, Government Inspector of Mines for the County of Durham, England.

Watt's Dictionary of Chemistry.

Supplementary Volume.

8vo. Cloth. \$9.00.

This volume brings the Record of Chemical Discovery down to the end of the year 1869, including also several additions to, and corrections of, former results which have appeared in 1870 and 1871.

* * Complete Sets of the Work, New and Revised edition, including above supplement. 6 vols. 8vo. Cloth. \$62.00.

Rammelsberg's Chemical Analysis.

8vo. Cloth. \$2.25.

GUIDE TO A COURSE OF QUANTITATIVE CHEMICAL ANALYSIS, ESPECIALLY OF MINERALS AND FURNACE PRODUCTS. Illustrated by Examples. By C. F. RAMMELSBERG. Translated by J. TOWLER, M.D.

This work has been translated, and is now published expressly for those students in chemistry whose time and other studies in colleges do not permit them to enter upon the more elaborate and expensive treatises of Fresenius and others. It is the condensed labor of a master in chemistry and of a practical analyst.

Eliot and Storer's Qualitative Chemical Analysis.

New Edition, Revised.

12mo. Illustrated. Cloth. \$1.50.

A COMPENDIOUS MANUAL OF QUALITATIVE CHEMICAL ANALYSIS. By CHARLES W. ELIOT and FRANK H. STORER. Revised with the Coöperation of the Authors, by WILLIAM RIPLEY NICHOLS, Professor of Chemistry in the Massachusetts Institute of Technology.

"This Manual has great merits as a practical introduction to the science and the art of which it treats. It contains enough of the theory and practice of qualitative analysis, "in the wet way," to bring out all the reasoning involved in the science, and to present clearly to the student the most approved methods of the art. It is specially adapted for exercises and experiments in the laboratory; and yet its classifications and manner of treatment are so systematic and logical throughout, as to adapt it in a high degree to that higher class of students generally who desire an accurate knowledge of the practical methods of arriving at scientific facts."—*Lutheran Observer*.

"We wish every academical class in the land could have the benefit of the fifty exercises of two hours each necessary to master this book. Chemistry would cease to be a mere matter of memory, and become a pleasant experimental and intellectual recreation. We heartily commend this little volume to the notice of those teachers who believe in using the sciences as means of mental discipline."—*College Courant*.

Craig's Decimal System.

Square 32mo. Limp. 50c.

WEIGHTS AND MEASURES. An Account of the Decimal System, with Tables of Conversion for Commercial and Scientific Uses. By B. F. CRAIG, M. D.

"The most lucid, accurate, and useful of all the hand-books on this subject that we have yet seen. It gives forty-seven tables of comparison between the English and French denominations of length, area, capacity, weight, and the Centigrade and Fahrenheit thermometers, with clear instructions how to use them; and to this practical portion, which helps to make the transition as easy as possible, is prefixed a scientific explanation of the errors in the metric system, and how they may be corrected in the laboratory."—*Nation*.

Nugent on Optics.

12mo. Cloth. \$2.00

TREATISE ON OPTICS; or, Light and Sight, theoretically and practically treated; with the application to Fine Art and Industrial Pursuits. By E. NUGENT. With one hundred and three illustrations.

“This book is of a practical rather than a theoretical kind, and is designed to afford accurate and complete information to all interested in applications of the science.”—*Round Table*.

Barnard's Metric System.

8vo. Brown cloth. \$3.00.

THE METRIC SYSTEM OF WEIGHTS AND MEASURES.

An Address delivered before the Convocation of the University of the State of New York, at Albany, August, 1871. By FREDERICK A. P. BARNARD, President of Columbia College, New York City. Second edition from the Revised edition printed for the Trustees of Columbia College. Tinted paper.

“It is the best summary of the arguments in favor of the metric weights and measures with which we are acquainted, not only because it contains in small space the leading facts of the case, but because it puts the advocacy of that system on the only tenable grounds, namely, the great convenience of a decimal notation of weight and measure as well as money, the value of international uniformity in the matter, and the fact that this metric system is adopted and in general use by the majority of civilized nations.”—*The Nation*.

Butler on Ventilation.

18mo. Boards. 50 cts.

VENTILATION OF BUILDINGS. By W. F. BUTLER.
Illustrated.

“As death by insensible suffocation is one of the prominent causes which swell our bills of mortality, we commend this book to the attention of philanthropists as well as to architects.”—*Boston Globe*.

Harrison's Mechanic's Tool-Book.

12mo. Cloth. \$1.50.

MECHANIC'S TOOL BOOK, with practical rules and suggestions, for the use of Machinists, Iron Workers, and others. By W. B. HARRISON, Associate Editor of the "American Artisan." Illustrated with 44 engravings.

"This work is specially adapted to meet the wants of Machinists and workers in iron generally. It is made up of the work-day experience of an intelligent and ingenious mechanic, who had the faculty of adapting tools to various purposes. The practicability of his plans and suggestions are made apparent even to the unpractised eye by a series of well-executed wood engravings."—*Philadelphia Inquirer*.

Pope's Modern Practice of the Electric Telegraph.

Ninth Edition. 8vo. Cloth \$2.00.

A Hand-book for Electricians and Operators. By FRANK L. POPE. Seventh edition. Revised and enlarged, and fully illustrated.

Extract from Letter of Prof. Morse.

"I have had time only cursorily to examine its contents, but this examination has resulted in great gratification, especially at the fairness and unprejudiced tone of your whole work.

"Your illustrated diagrams are admirable and beautifully executed.

"I think all your instructions in the use of the telegraph apparatus judicious and correct, and I most cordially wish you success."

Extract from Letter of Prof. G. W. Hough, of the Dudley Observatory.

"There is no other work of this kind in the English language that contains in so small a compass so much practical information in the application of galvanic electricity to telegraphy. It should be in the hands of every one interested in telegraphy, or the use of Batteries for other purposes."

Morse's Telegraphic Apparatus.

Illustrated. 8vo. Cloth. \$2.00.

EXAMINATION OF THE TELEGRAPHIC APPARATUS AND THE PROCESSES IN TELEGRAPHY. By SAMUEL F. B. MORSE, LL.D., United States Commissioner Paris Universal Exposition, 1867.

Sabine's History of the Telegraph.

12mo. Cloth. \$1.25.

HISTORY AND PROGRESS OF THE ELECTRIC TELEGRAPH, with Descriptions of some of the Apparatus. By ROBERT SABINE, C. E. Second edition, with additions.

CONTENTS.—I. Early Observations of Electrical Phenomena. II. Telegraphs by Frictional Electricity. III. Telegraphs by Voltaic Electricity. IV. Telegraphs by Electro-Magnetism and Magneto-Electricity. V. Telegraphs now in use. VI. Overhead Lines. VII. Submarine Telegraph Lines. VIII. Underground Telegraphs. IX. Atmospheric Electricity.

Haskins' Galvanometer.

Pocket form. Illustrated. Morocco tucks. \$2.00.

THE GALVANOMETER, AND ITS USES; a Manual for Electricians and Students. By C. H. HASKINS.

"We hope this excellent little work will meet with the sale its merits entitle it to. To every telegrapher who owns, or uses a Galvanometer, or ever expects to, it will be quite indispensable."—*The Telegrapher*.

Culley's Hand-Book of Telegraphy.

8vo. Cloth. \$5.00.

A HAND-BOOK OF PRACTICAL TELEGRAPHY. By R. S. CULLEY, Engineer to the Electric and International Telegraph Company. Fifth edition, revised and enlarged.

Foster's Submarine Blasting.

4to. Cloth. \$3.50.

SUBMARINE BLASTING in Boston Harbor, Massachusetts—Removal of Tower and Corwin Rocks. By JOHN G. FOSTER, Lieutenant-Colonel of Engineers, and Brevet Major-General, U. S. Army. Illustrated with seven plates.

LIST OF PLATES.—1. Sketch of the Narrows, Boston Harbor. 2. Townsend's Submarine Drilling Machine, and Working Vessel attending. 3. Submarine Drilling Machine employed. 4. Details of Drilling Machine employed. 5. Cartridges and Tamping used. 6. Fuses and Insulated Wires used. 7. Portable Friction Battery used.

Barnes' Submarine Warfare.

8vo. Cloth. \$5.00.

SUBMARINE WARFARE, DEFENSIVE AND OFFENSIVE.

Comprising a full and complete History of the Invention of the Torpedo, its employment in War and results of its use. Descriptions of the various forms of Torpedoes, Submarine Batteries and Torpedo Boats actually used in War. Methods of Ignition by Machinery, Contact Fuzes, and Electricity, and a full account of experiments made to determine the Explosive Force of Gunpowder under Water. Also a discussion of the Offensive Torpedo system, its effect upon Iron-Clad Ship systems, and influence upon Future Naval Wars. By Lieut.-Commander JOHN S. BARNES, U. S. N. With twenty lithographic plates and many wood-cuts.

“A book important to military men, and especially so to engineers and artillerymen. It consists of an examination of the various offensive and defensive engines that have been contrived for submarine hostilities, including a discussion of the torpedo system, its effects upon iron-clad ship-systems, and its probable influence upon future naval wars. Plates of a valuable character accompany the treatise, which affords a useful history of the momentous subject it discusses. A great deal of useful information is collected in its pages, especially concerning the inventions of SCHOLL and VERDU, and of JONES' and HUNT's batteries, as well as of other similar machines, and the use in submarine operations of gun-cotton and nitro-glycerine.”—*N. Y. Times*.

Randall's Quartz Operator's Hand-Book.

12mo. Cloth. \$2.00.

QUARTZ OPERATOR'S HAND-BOOK. By P. M. RANDALL.
New edition, revised and enlarged. Fully illustrated.

The object of this work has been to present a clear and comprehensive exposition of mineral veins, and the means and modes chiefly employed for the mining and working of their ores—more especially those containing gold and silver.

McCulloch's Theory of Heat.

Svo. Cloth. In Press.

AN ELEMENTARY TREATISE, ON THE MECHANICAL THEORY OF HEAT, AND ITS APPLICATION TO AIR AND STEAM ENGINES. By Prof. R. S. McCULLOCH.

Benét's Chronoscope.

Second Edition.

Illustrated. 4to. Cloth. \$3.00.

ELECTRO-BALLISTIC MACHINES, and the Schultz Chronoscope. By Lieutenant-Colonel S. V. BENÉT, Captain of Ordnance, U. S. Army.

CONTENTS.—1. Ballistic Pendulum. 2. Gun Pendulum. 3. Use of Electricity. 4. Navez' Machine. 5. Vignotti's Machine, with Plates. 6. Benton's Electro-Ballistic Pendulum, with Plates. 7. Leur's Tro-Pendulum Machine. 8. Schultz's Chronoscope, with two Plates.

Michaelis' Chronograph.

4to. Illustrated. Cloth. \$3.00.

THE LE BOULENGÉ CHRONOGRAPH. With three lithographed folding plates of illustrations. By Brevet Captain O E. MICHAELIS, First Lieutenant Ordnance Corps, U. S. Army.

"The excellent monograph of Captain Michaelis enters minutely into the details of construction and management, and gives tables of the times of flight calculated upon a given fall of the chronometer for all distances. Captain Michaelis has done good service in presenting this work to his brother officers, describing, as it does, an instrument which bids fair to be in constant use in our future ballistic experiments."—*Army and Navy Journal*

Silversmith's Hand-Book.

Fourth Edition.

Illustrated. 12mo. Cloth. \$3.00.

A PRACTICAL HAND-BOOK FOR MINERS, Metallurgists, and Assayers, comprising the most recent improvements in the disintegration, amalgamation, smelting, and parting of the Precious Ores, with a Comprehensive Digest of the Mining Laws. Greatly augmented, revised, and corrected. By JULIUS SILVERSMITH. Fourth edition. Profusely illustrated. 1 vol. 12mo. Cloth. \$3.00.

One of the most important features of this work is that in which the metallurgy of the precious metals is treated of. In it the author has endeavored to embody all the processes for the reduction and manipulation of the precious ores heretofore successfully employed in Germany, England, Mexico, and the United States, together with such as have been more recently invented, and not yet fully tested—all of which are profusely illustrated and easy of comprehension.

Simms' Levelling.

8vo. Cloth. \$2.50.

A TREATISE ON THE PRINCIPLES AND PRACTICE OF LEVELLING, showing its application to purposes of Railway Engineering and the Construction of Roads, &c. By FREDERICK W. SIMMS, C. E. From the fifth London edition, revised and corrected, with the addition of Mr. Law's Practical Examples for Setting Out Railway Curves. Illustrated with three lithographic plates and numerous wood-cuts.

“One of the most important text-books for the general surveyor, and there is scarcely a question connected with levelling for which a solution would be sought, but that would be satisfactorily answered by consulting this volume.”
—*Mining Journal*.

“The text-book on levelling in most of our engineering schools and colleges.”—*Engineers*.

“The publishers have rendered a substantial service to the profession, especially to the younger members, by bringing out the present edition of Mr. Simms' useful work.”—*Engineering*.

Stuart's Successful Engineer.

18mo. Boards. 50 cents.

HOW TO BECOME A SUCCESSFUL ENGINEER: Being Hints to Youths intending to adopt the Profession. By BERNARD STUART, Engineer. Sixth Edition.

"A valuable little book of sound, sensible advice to young men who wish to rise in the most important of the professions."—*Scientific American*.

Stuart's Naval Dry Docks.

Twenty-four engravings on steel.

Fourth Edition.

4to. Cloth. \$6.00.

THE NAVAL DRY DOCKS OF THE UNITED STATES.

By CHARLES B. STUART. Engineer in Chief of the United States Navy.

List of Illustrations.

Pumping Engine and Pumps—Plan of Dry Dock and Pump-Well—Sections of Dry Dock—Engine House—Iron Floating Gate—Details of Floating Gate—Iron Turning Gate—Plan of Turning Gate—Culvert Gate—Filling Culvert Gates—Engine Bed—Plate, Pumps, and Culvert—Engine House Roof—Floating Sectional Dock—Details of Section, and Plan of Turn-Tables—Plan of Basin and Marine Railways—Plan of Sliding Frame, and Elevation of Pumps—Hydraulic Cylinder—Plan of Gearing for Pumps and End Floats—Perspective View of Dock, Basin, and Railway—Plan of Basin of Portsmouth Dry Dock—Floating Balance Dock—Elevation of Trusses and the Machinery—Perspective View of Balance Dry Dock

Free Hand Drawing.

Profusely Illustrated. 18mo. Boards. 50 cents.

A GUIDE TO ORNAMENTAL, Figure, and Landscape Drawing. By an Art Student.

CONTENTS.—Materials employed in Drawing, and how to use them—On Lines and how to Draw them—On Shading—Concerning lines and shading, with applications of them to simple elementary subjects—Sketches from Nature.

Minifie's Mechanical Drawing.

Ninth Edition.

Royal 8vo. Cloth. \$4.00.

A TEXT-BOOK OF GEOMETRICAL DRAWING for the use of Mechanics and Schools, in which the Definitions and Rules of Geometry are familiarly explained; the Practical Problems are arranged, from the most simple to the more complex, and in their description technicalities are avoided as much as possible. With illustrations for Drawing Plans, Sections, and Elevations of Buildings and Machinery; an Introduction to Isometrical Drawing, and an Essay on Linear Perspective and Shadows. Illustrated with over 200 diagrams engraved on steel. By WM. MINIFIE, Architect. Eighth Edition. With an Appendix on the Theory and Application of Colors.

"It is the best work on Drawing that we have ever seen, and is especially a text-book of Geometrical Drawing for the use of Mechanics and Schools. No young Mechanic, such as a Machinist, Engineer, Cabinet-Maker, Millwright, or Carpenter, should be without it."—*Scientific American*.

"One of the most comprehensive works of the kind ever published, and cannot but possess great value to builders. The style is at once elegant and substantial."—*Pennsylvania Inquirer*.

"Whatever is said is rendered perfectly intelligible by remarkably well-executed diagrams on steel, leaving nothing for mere vague supposition; and the addition of an introduction to isometrical drawing, linear perspective, and the projection of shadows, winding up with a useful index to technical terms."—*Glasgow Mechanics' Journal*.

 The British Government has authorized the use of this book in their schools of art at Somerset House, London, and throughout the kingdom.

Minifie's Geometrical Drawing.

New Edition. Enlarged.

12mo. Cloth. \$2.00.

GEOMETRICAL DRAWING. Abridged from the octavo edition, for the use of Schools. Illustrated with 48 steel plates. New edition, enlarged.

"It is well adapted as a text-book of drawing to be used in our High Schools and Academies where this useful branch of the fine arts has been hitherto too much neglected."—*Boston Journal*.

Bell on Iron Smelting.

8vo. Cloth. \$6.00.

CHEMICAL PHENOMENA OF IRON SMELTING. An experimental and practical examination of the circumstances which determine the capacity of the Blast Furnace, the Temperature of the Air, and the Proper Condition of the Materials to be operated upon. By I. LOWTHIAN BELL.

“The reactions which take place in every foot of the blast-furnace have been investigated, and the nature of every step in the process, from the introduction of the raw material into the furnace to the production of the pig iron, has been carefully ascertained, and recorded so fully that any one in the trade can readily avail themselves of the knowledge acquired; and we have no hesitation in saying that the judicious application of such knowledge will do much to facilitate the introduction of arrangements which will still further economize fuel, and at the same time permit of the quality of the resulting metal being maintained, if not improved. The volume is one which no practical pig iron manufacturer can afford to be without if he be desirous of entering upon that competition which nowadays is essential to progress, and in issuing such a work Mr. Bell has entitled himself to the best thanks of every member of the trade.”—*London Mining Journal*.

King's Notes on Steam.

Nineteenth Edition.

8vo. Cloth. \$2.00.

LESSONS AND PRACTICAL NOTES ON STEAM, the Steam-Engine, Propellers, &c., &c., for Young Engineers, Students, and others. By the late W. R. KING, U. S. N. Revised by Chief-Engineer J. W. KING, U. S. Navy.

“This is one of the best, because eminently plain and practical treatises on the Steam Engine ever published.”—*Philadelphia Press*.

This is the thirteenth edition of a valuable work of the late W. H. King, U. S. N. It contains lessons and practical notes on Steam and the Steam Engine, Propellers, etc. It is calculated to be of great use to young marine engineers, students, and others. The text is illustrated and explained by numerous diagrams and representations of machinery.—*Boston Daily Advertiser*.

Text-book at the U. S. Naval Academy, Annapolis.

Burgh's Modern Marine Engineering.

One thick 4to vol. Cloth. \$25.00. Half morocco. \$30.00.

MODERN MARINE ENGINEERING, applied to Paddle and Screw Propulsion. Consisting of 36 Colored Plates, 259 Practical Wood-cut Illustrations, and 403 pages of Descriptive Matter, the whole being an exposition of the present practice of the following firms: Messrs. J. Penn & Sons; Messrs. Maudslay, Sons & Field; Messrs. James Watt & Co.; Messrs. J. & G. Renzie; Messrs. R. Napier & Sons; Messrs. J. & W. Dudgeon; Messrs. Ravenhill & Hodgson; Messrs. Humphreys & Tenant; Mr. J. T. Spencer, and Messrs. Forrester & Co. By N. P. BURGH, Engineer.

PRINCIPAL CONTENTS.—General Arrangements of Engines, 11 examples—General Arrangement of Boilers, 14 examples—General Arrangement of Superheaters, 11 examples—Details of Oscillating Paddle Engines, 34 examples—Condensers for Screw Engines, both Injection and Surface, 20 examples—Details of Screw Engines, 20 examples—Cylinders and Details of Screw Engines, 21 examples—Slide Valves and Details, 7 examples—Slide Valve, Link Motion, 7 examples—Expansion Valves and Gear, 10 examples—Details in General, 30 examples—Screw Propeller and Fittings, 13 examples—Engine and Boiler Fittings, 28 examples—In relation to the Principles of the Marine Engine and Boiler, 33 examples.

Notices of the Press.

“Every conceivable detail of the Marine Engine, under all its various forms, is profusely, and we must add, admirably illustrated by a multitude of engravings, selected from the best and most modern practice of the first Marine Engineers of the day. The chapter on Condensers is peculiarly valuable. In one word, there is no other work in existence which will bear a moment's comparison with it as an exponent of the skill, talent and practical experience to which is due the splendid reputation enjoyed by many British Marine Engineers.”—*Engineer*.

“This very comprehensive work, which was issued in Monthly parts, has just been completed. It contains large and full drawings and copious descriptions of most of the best examples of Modern Marine Engines, and it is a complete theoretical and practical treatise on the subject of Marine Engineering.”—*American Artisan*.

This is the only edition of the above work with the beautifully colored plates, and it is out of print in England.

Bourne's Treatise on the Steam Engine.

Ninth Edition.

Illustrated. 4to. Cloth. \$15.00.

TREATISE ON THE STEAM ENGINE in its various applications to Mines, Mills, Steam Navigation, Railways, and Agriculture, with the theoretical investigations respecting the Motive Power of Heat and the proper Proportions of Steam Engines. Elaborate Tables of the right dimensions of every part, and Practical Instructions for the Manufacture and Management of every species of Engine in actual use. By JOHN BOURNE, being the ninth edition of "A Treatise on the Steam Engine," by the "Artisan Club." Illustrated by thirty-eight plates and five hundred and forty-six wood-cuts.

As Mr. Bourne's work has the great merit of avoiding unsound and immature views, it may safely be consulted by all who are really desirous of acquiring trustworthy information on the subject of which it treats. During the twenty-two years which have elapsed from the issue of the first edition, the improvements introduced in the construction of the steam engine have been both numerous and important, and of these Mr. Bourne has taken care to point out the more prominent, and to furnish the reader with such information as shall enable him readily to judge of their relative value. This edition has been thoroughly modernized, and made to accord with the opinions and practice of the more successful engineers of the present day. All that the book professes to give is given with ability and evident care. The scientific principles which are permanent are admirably explained, and reference is made to many of the more valuable of the recently introduced engines. To express an opinion of the value and utility of such a work as *The Artisan Club's Treatise on the Steam Engine*, which has passed through eight editions already, would be superfluous; but it may be safely stated that the work is worthy the attentive study of all either engaged in the manufacture of steam engines or interested in economizing the use of steam.—*Mining Journal*.

Isherwood's Engineering Precedents.

Two Vols. in One. 8vo. Cloth. \$2.50.

ENGINEERING PRECEDENTS FOR STEAM MACHINERY.

Arranged in the most practical and useful manner for Engineers. By B. F. ISHERWOOD, Civil Engineer, U. S. Navy. With illustrations.

Ward's Steam for the Million.

New and Revised Edition.

8vo. Cloth. \$1.00.

STEAM FOR THE MILLION. A Popular Treatise on Steam and its Application to the Useful Arts, especially to Navigation. By J. H. WARD, Commander U. S. Navy. New and revised edition.

A most excellent work for the young engineer and general reader. Many facts relating to the management of the boiler and engine are set forth with a simplicity of language and perfection of detail that bring the subject home to the reader.—*American Engineer.*

Walker's Screw Propulsion.

8vo. Cloth. 75 cents.

NOTES ON SCREW PROPULSION, its Rise and History. By Capt. W. H. WALKER, U. S. Navy.

Commander Walker's book contains an immense amount of concise practical data, and every item of information recorded fully proves that the various points bearing upon it have been well considered previously to expressing an opinion.—*London Mining Journal.*

Page's Earth's Crust.

18mo. Cloth. 75 cents.

THE EARTH'S CRUST: a Handy Outline of Geology. By DAVID PAGE.

"Such a work as this was much wanted—a work giving in clear and intelligible outline the leading facts of the science, without amplification or irksome details. It is admirable in arrangement, and clear and easy, and, at the same time, forcible in style. It will lead, we hope, to the introduction of Geology into many schools that have neither time nor room for the study of large treatises."—*The Museum.*

Rogers' Geology of Pennsylvania.

3 Vols. 4to, with Portfolio of Maps. Cloth. \$30.00.

THE GEOLOGY OF PENNSYLVANIA. A Government Survey. With a general view of the Geology of the United States, Essays on the Coal Formation and its Fossils, and a description of the Coal Fields of North America and Great Britain. By HENRY DARWIN ROGERS, Late State Geologist of Pennsylvania. Splendidly illustrated with Plates and Engravings in the Text.

It certainly should be in every public library throughout the country, and likewise in the possession of all students of Geology. After the final sale of these copies, the work will, of course, become more valuable.

The work for the last five years has been entirely out of the market, but a few copies that remained in the hands of Prof. Rogers, in Scotland, at the time of his death, are now offered to the public, at a price which is even below what it was originally sold for when first published.

Morfit on Pure Fertilizers.

With 28 Illustrative Plates. 8vo. Cloth. \$20.00.

A PRACTICAL TREATISE ON PURE FERTILIZERS, and the Chemical Conversion of Rock Guanos, Marlstones, Coprolites, and the Crude Phosphates of Lime and Alumina Generally, into various Valuable Products. By CAMPBELL MORFIT, M.D., F.C.S.

Sweet's Report on Coal.

8vo. Cloth. \$3.00.

SPECIAL REPORT ON COAL; showing its Distribution, Classification, and Cost delivered over different routes to various points in the State of New York, and the principal cities on the Atlantic Coast. By S. H. SWEET. With maps.

Colburn's Gas Works of London.

12mo. Boards. 60 cents.

GAS WORKS OF LONDON. By ZERAH COLBURN.

The Useful Metals and their Alloys; Scoffren, Truran, and others.

Fifth Edition.

8vo. Half calf. \$3.75.

THE USEFUL METALS AND THEIR ALLOYS, including MINING VENTILATION, MINING JURISPRUDENCE AND METALLURGIC CHEMISTRY employed in the conversion of IRON, COPPER, TIN, ZINC, ANTIMONY, AND LEAD ORES, with their applications to THE INDUSTRIAL ARTS. By JOHN SCOFFREN, WILLIAM TRURAN, WILLIAM CLAY, ROBERT OXLAND, WILLIAM FAIRBAIRN, W. C. ATKIN, and WILLIAM VOSE PICKETT.

Collins' Useful Alloys.

18mo. Flexible. 75 cents.

THE PRIVATE BOOK OF USEFUL ALLOYS and Memoranda for Goldsmiths, Jewellers, etc. By JAMES E. COLLINS

This little book is compiled from notes made by the Author from the papers of one of the largest and most eminent Manufacturing Goldsmiths and Jewellers in this country, and as the firm is now no longer in existence, and the Author is at present engaged in some other undertaking, he now offers to the public the benefit of his experience, and in so doing he begs to state that all the alloys, etc., given in these pages may be confidently relied on as being thoroughly practicable.

The Memoranda and Receipts throughout this book are also compiled from practice, and will no doubt be found useful to the practical jeweller. —*Shirley, July, 1871.*

Joynson's Metals Used in Construction.

12mo. Cloth. 75 cents.

THE METALS USED IN CONSTRUCTION: Iron, Steel, Bessemer Metal, etc., etc. By FRANCIS HERBERT JOYNSON. Illustrated.

“In the interests of practical science, we are bound to notice this work; and to those who wish further information, we should say, buy it; and the outlay, we honestly believe, will be considered well spent.” —*Scientific Review.*

Prescott's Proximate Organic Analysis.

12mo. Cloth. \$1.75.

OUTLINES OF PROXIMATE ORGANIC ANALYSIS for the Identification, Separation, and Quantitative Determination of the more commonly occurring Organic Compounds. By ALBERT B. PRESCOTT, Professor of Organic and Applied Chemistry in the University of Michigan.

Prescott's Alcoholic Liquors.

12mo. Cloth. \$1.50.

CHEMICAL EXAMINATION OF ALCOHOLIC LIQUORS. A Manual of the Constituents of the Distilled Spirits and Fermented Liquors of Commerce, and their Qualitative and Quantitative Determinations. By ALBERT B. PRESCOTT, Professor of Organic and Applied Chemistry in the University of Michigan.

Greene's Bridge Trusses.

8vo. Illustrated. Cloth. \$2.00.

GRAPHICAL METHOD FOR THE ANALYSIS OF BRIDGE TRUSSES, extended to Continuous Girders and Draw Spans. By CHARLES E. GREENE, A.M., Professor of Civil Engineering, University of Michigan. Illustrated by three folding plates.

Butler's Projectiles and Rifled Cannon.

4to. 36 Plates. Cloth. \$7.50.

PROJECTILES AND RIFLED CANNON. A Critical Discussion of the Principal Systems of Rifling and Projectiles, with practical suggestions for their improvement, as embraced in a report to the Chief of Ordnance, U. S. Army. By Capt. JOHN S. BUTLER, Ordnance Corps, U. S. A.

Peirce's Analytic Mechanics.

4to. Cloth. \$10.00.

SYSTEM OF ANALYTIC MECHANICS. Physical and Celestial Mechanics. By BENJAMIN PEIRCE, Perkins Professor of Astronomy and Mathematics in Harvard University, and Consulting Astronomer of the American Ephemeris and Nautical Almanac. Developed in four systems of Analytic Mechanics, Celestial Mechanics, Potential Physics, and Analytic Morphology.

"I have re-examined the memoirs of the great geometers, and have striven to consolidate their latest researches and their most exalted forms of thought into a consistent and uniform treatise. If I have hereby succeeded in opening to the students of my country a readier access to these choice jewels of intellect; if their brilliancy is not impaired in this attempt to reset them; if, in their own constellation, they illustrate each other, and concentrate a stronger light upon the names of their discoverers, and, still more, if any gem which I may have presumed to add is not wholly lustreless in the collection, I shall feel that my work has not been in vain."—*Extract from the Preface.*

Burt's Key to Solar Compass.

Second Edition.

Pocket Book Form. Tuck. \$2.50.

KEY TO THE SOLAR COMPASS, and Surveyor's Companion; comprising all the Rules necessary for use in the field; also, Description of the Linear Surveys and Public Land System of the United States, Notes on the Barometer, Suggestions for an outfit for a Survey of four months, etc., etc., etc. By W. A. BURR, U. S. Deputy Surveyor. Second edition.

Chauvenet's Lunar Distances.

8vo. Cloth. \$2.00.

NEW METHOD OF CORRECTING LUNAR DISTANCES, and Improved Method of Finding the Error and Rate of a Chronometer, by equal altitudes. By WM. CHAUVENET, LL.D., Chancellor of Washington University of St. Louis.

Jeffers' Nautical Surveying.

Illustrated with 9 Copperplates and 31 Wood-cut Illustrations. 8vo.
Cloth. \$5.00.

NAUTICAL SURVEYING. By WILLIAM N. JEFFERS, Captain
U. S. Navy.

Many books have been written on each of the subjects treated of in the sixteen chapters of this work; and, to obtain a complete knowledge of geodetic surveying requires a profound study of the whole range of mathematical and physical sciences; but a year of preparation should render any intelligent officer competent to conduct a nautical survey.

CONTENTS.—Chapter I. Formulæ and Constants Useful in Surveying
II. Distinctive Character of Surveys. III. Hydrographic Surveying under Sail; or, Running Survey. IV. Hydrographic Surveying of Boats; or, Harbor Survey. V. Tides—Definition of Tidal Phenomena—Tidal Observations. VI. Measurement of Bases—Appropriate and Direct. VII. Measurement of the Angles of Triangles—Azimuths—Astronomical Bearings. VIII. Corrections to be Applied to the Observed Angles. IX. Levelling—Difference of Level. X. Computation of the Sides of the Triangulation—The Three-point Problem. XI. Determination of the Geodetic Latitudes, Longitudes, and Azimuths, of Points of a Triangulation. XII. Summary of Subjects treated of in preceding Chapters—Examples of Computation by various Formulæ. XIII. Projection of Charts and Plans. XIV. Astronomical Determination of Latitude and Longitude. XV. Magnetic Observations. XVI. Deep Sea Soundings. XVII. Tables for Ascertaining Distances at Sea, and a full Index.

List of Plates.

Plate I. Diagram Illustrative of the Triangulation. II. Specimen Page of Field Book. III. Running Survey of a Coast. IV. Example of a Running Survey from Belcher. V. Flying Survey of an Island. VI. Survey of a Shoal. VII. Boat Survey of a River. VIII. Three-Point Problem. IX. Triangulation.

Coffin's Navigation.

Fifth Edition.

12mo. Cloth. \$3.50.

NAVIGATION AND NAUTICAL ASTRONOMY. Prepared for the use of the U. S. Naval Academy. By J. H. C. COFFIN, Prof. of Astronomy, Navigation and Surveying, with 52 wood-cut illustrations.

Clark's Theoretical Navigation.

8vo. Cloth. \$3.00.

THEORETICAL NAVIGATION AND NAUTICAL ASTRONOMY. By LEWIS CLARK, Lieut.-Commander, U. S. Navy. Illustrated with 41 Wood-cuts, including the Vernier.

Prepared for Use at the U. S. Naval Academy.

The Plane Table.

Illustrated. 8vo. Cloth. \$2.00.

ITS USES IN TOPOGRAPHICAL SURVEYING. From the Papers of the U. S. Coast Survey.

This work gives a description of the Plane Table employed at the U. S. Coast Survey Office, and the manner of using it.

Pook on Shipbuilding.

8vo. Cloth. \$5.00.

METHOD OF COMPARING THE LINES AND DRAUGHTING VESSELS PROPELLED BY SAIL OR STEAM, including a Chapter on Laying off on the Mould-Loft Floor. By SAMUEL M. POOK, Naval Constructor. 1 vol., 8vo. With illustrations. Cloth. \$5.00.

Brunnow's Spherical Astronomy.

8vo. Cloth. \$6.50.

SPHERICAL ASTRONOMY. By F. BRUNNOW, Ph. Dr. Translated by the Author from the Second German edition.

Van Buren's Formulas.

8vo. Cloth. \$2.00.

INVESTIGATIONS OF FORMULAS, for the Strength of the Iron Parts of Steam Machinery. By J. D. VAN BUREN, JR., C. E. Illustrated.

This is an analytical discussion of the formulæ employed by mechanical engineers in determining the rupturing or crippling pressure in the different parts of a machine. The formulæ are founded upon the principle, that the different parts of a machine should be equally strong, and are developed in reference to the ultimate strength of the material in order to leave the choice of a factor of safety to the judgment of the designer.—*Silliman's Journal*.

Joynson on Machine Gearing.

8vo. Cloth. \$2.00.

THE MECHANIC'S AND STUDENT'S GUIDE in the Designing and Construction of General Machine Gearing, as Eccentrics, Screws, Toothed Wheels, etc., and the Drawing of Rectilinear and Curved Surfaces ; with Practical Rules and Details. Edited by FRANCIS HERBERT JOYNSON. Illustrated with 18 folded plates.

"The aim of this work is to be a guide to mechanics in the designing and construction of general machine-gearing. This design it well fulfils, being plainly and sensibly written, and profusely illustrated."—*Sunday Times*.

Barnard's Report, Paris Exposition, 1867.

Illustrated. 8vo. Cloth. \$5.00.

REPORT ON MACHINERY AND PROCESSES ON THE INDUSTRIAL ARTS AND APPARATUS OF THE EXACT SCIENCES. By F. A. P. BARNARD, LL.D.—Paris Universal Exposition, 1867.

"We have in this volume the results of Dr. Barnard's study of the Paris Exposition of 1867, in the form of an official Report of the Government. It is the most exhaustive treatise upon modern inventions that has appeared since the Universal Exhibition of 1851, and we doubt if anything equal to it has appeared this century."—*Journal Applied Chemistry*.

Engineering Facts and Figures.

18mo. Cloth. \$2.50 per Volume.

AN ANNUAL REGISTER OF PROGRESS IN MECHANICAL ENGINEERING AND CONSTRUCTION, for the Years 1863-64-65-66-67-68. Fully illustrated. 6 volumes.

Each volume sold separately.

Beckwith's Pottery.

8vo. Paper. 60 cents.

OBSERVATIONS ON THE MATERIALS and Manufacture of Terra-Cotta, Stone-Ware, Fire-Brick, Porcelain and Encaustic Tiles, with Remarks on the Products exhibited at the London International Exhibition, 1871. By ARTHUR BECKWITH, Civil Engineer.

“Everything is noticed in this book which comes under the head of Pottery, from fine porcelain to ordinary brick, and aside from the interest which all take in such manufactures, the work will be of considerable value to followers of the ceramic art.”—*Evening Mail*.

Dodd's Dictionary of Manufactures, etc.

12mo. Cloth. \$2.00.

DICTIONARY OF MANUFACTURES, MINING, MACHINERY, AND THE INDUSTRIAL ARTS. By GEORGE DODD.

This work, a small book on a great subject, treats, in alphabetical arrangement, of those numerous matters which come generally within the range of manufactures and the productive arts. The raw materials—animal, vegetable, and mineral—whence the manufactured products are derived, are succinctly noticed in connection with the processes which they undergo, but not as subjects of natural history. The operations of the Mine and the Mill, the Foundry and the Forge, the Factory and the Workshop, are passed under review. The principal machines and engines, tools and apparatus, concerned in manufacturing processes, are briefly described. The scale on which our chief branches of national industry are conducted, in regard to values and quantities, is indicated in various ways.

Stuart's Civil and Military Engineering of America.

8vo. Illustrated. Cloth. \$5.00.

THE CIVIL AND MILITARY ENGINEERS OF AMERICA.

By General CHARLES B. STUART, Author of "Naval Dry Docks of the United States," etc., etc. Embellished with nine finely executed portraits on steel of eminent engineers, and illustrated by engravings of some of the most important and original works constructed in America.

Containing sketches of the Life and Works of Major Andrew Ellicott, James Geddes (with Portrait), Benjamin Wright (with Portrait), Canvass White (with Portrait), David Stanhope Bates, Nathan S. Roberts, Gridley Bryant (with Portrait), General Joseph G. Swift, Jesse L. Williams (with Portrait), Colonel William McRee, Samuel H. Kneass, Captain John Childe (with Portrait), Frederick Harbach, Major David Bates Douglas (with Portrait), Jonathan Knight, Benjamin H. Latrobe (with Portrait), Colonel Charles Ellet, Jr. (with Portrait), Samuel Forrer, William Stuart Watson, John A. Roebling.

Alexander's Dictionary of Weights and Measures.

8vo. Cloth. \$3.50.

UNIVERSAL DICTIONARY OF WEIGHTS AND MEASURES, Ancient and Modern, reduced to the standards of the United States of America. By J. H. ALEXANDER. New edition. 1 vol.

"As a standard work of reference, this book should be in every library; it is one which we have long wanted, and it will save much trouble and research."—*Scientific American*.

Blake's Ceramic Art.

8vo. Cloth. \$2.00.

A REPORT ON POTTERY, PORCELAIN, TILES, TERRACOTTA, AND BRICK. By WILLIAM P. BLAKE, United States Commissioner Internal Exhibition at Vienna, 1873.

Saeltzer's Acoustics.

12mo. Cloth. \$2.00.

TREATISE ON ACOUSTICS in Connection with Ventilation.

With a new theory based on an important discovery, of facilitating clear and intelligible sound in any building. By ALEXANDER SAELTZER.

"A practical and very sound treatise on a subject of great importance to architects, and one to which there has hitherto been entirely too little attention paid. The author's theory is, that, by bestowing proper care upon the point of Acoustics, the requisite ventilation will be obtained, and *vice versa*.—*Brooklyn Union*.

Myer's Manual of Signals.

New Edition. Enlarged.

12mo. 48 Plates full Roan. \$5.00.

MANUAL OF SIGNALS, for the Use of Signal Officers in the Field, and for Military and Naval Students, Military Schools, etc. A new edition, enlarged and illustrated. By Brig.-Gen. ALBERT J. MYER, Chief Signal Officer of the Army, Colonel of the Signal Corps during the War of the Rebellion.

Larrabee's Secret Letter and Telegraph Code.

18mo. Cloth. \$1.00.

CIPHER AND SECRET LETTER AND TELEGRAPHIC CODE, with Hogg's Improvements. The most perfect secret Code ever invented or discovered. Impossible to read without the Key. Invaluable for Secret, Military, Naval, and Diplomatic Service, as well as for Brokers, Bankers, and Merchants. By C. S. LARRABEE, the original inventor of the scheme.

Hunt's Designs for Central Park Gateways.

4to. Cloth. \$5.00.

DESIGNS FOR THE GATEWAYS OF THE SOUTHERN ENTRANCES TO THE CENTRAL PARK. By RICHARD M. HUNT. With a description of the designs.

Pickert and Metcalf's Art of Graining.

1 vol. 4to. Cloth. \$10.00.

THE ART OF GRAINING. How Acquired and How Produced, with description of colors and their application. By CHARLES PICKERT and ABRAHAM METCALF. Beautifully illustrated with 42 tinted plates of the various woods used in interior finishing. Tinted paper.

The authors present here the result of long experience in the practice of this decorative art, and feel confident that they hereby offer to their brother artisans a reliable guide to improvement in the practice of graining.

Portrait Gallery of the War.

60 fine Portraits on Steel. Royal 8vo. Cloth. \$6.00.

PORTRAIT GALLERY OF THE WAR, CIVIL, MILITARY AND NAVAL. A Biographical Record. Edited by FRANK MOORE.

One Law in Nature.

12mo. Cloth. \$1.50.

ONE LAW IN NATURE. By Capt. H. M. LAZELLE, U. S. A. A New Corpuscular Theory, comprehending Unity of Force, Identity of Matter, and its Multiple Atom Constitution, applied to the Physical Affections or Modes of Energy.

Ernst's Manual of Military Engineering.

193 Wood Cuts and 3 Lithographed Plates. 12mo. Cloth. \$5.00.

A MANUAL OF PRACTICAL MILITARY ENGINEERING. Prepared for the use of the Cadets of the U. S. Military Academy, and for Engineer Troops. By Capt. O. H. ERNST, Corps of Engineers, Instructor in Practical Military Engineering, U. S. Military Academy.

Church's Metallurgical Journey.

24 Illustrations. 8vo. Cloth. \$2.00.

NOTES OF A METALLURGICAL JOURNEY IN EUROPE. By JOHN A. CHURCH, Engineer of Mines.

Blake's Precious Metals.

8vo. Cloth. \$2.00.

REPORT UPON THE PRECIOUS METALS: Being Statistical Notices of the principal Gold and Silver producing regions of the World. Represented at the Paris Universal Exposition. By WILLIAM P. BLAKE, Commissioner from the State of California.

Clevenger's Surveying.

Illustrated Pocket Form. Morocco Gilt. \$2.50.

A TREATISE ON THE METHOD OF GOVERNMENT SURVEYING, as prescribed by the United States Congress and Commissioner of the General Land Office. With complete Mathematical, Astronomical and Practical Instructions, for the use of the United States Surveyors in the Field, and Students who contemplate engaging in the business of Public Land Surveying. By S. R. CLEVENGER, U. S. Deputy Surveyor.

"The reputation of the author as a surveyor guarantees an exhaustive treatise on this subject."—*Dakota Register*.

"Surveyors have long needed a text-book of this description.—*The Press*."

Bow on Bracing.

156 Illustrations on Stone. 8vo. Cloth. \$1.50.

A TREATISE ON BRACING, with its application to Bridges and other Structures of Wood or Iron. By ROBERT HENRY BOW, C. E.

Howard's Earthwork Mensuration.

8vo. Illustrated. Cloth. \$1.50.

EARTHWORK MENSURATION ON THE BASIS OF THE PRISMOIDAL FORMULÆ. Containing simple and labor-saving method of obtaining Prismoidal Contents directly from End Areas. Illustrated by Examples, and accompanied by Plain Rules for practical uses. By CONWAY R. HOWARD, Civil Engineer, Richmond, Va.

“Major Howard has given in this book a simple, yet perfectly accurate method of ascertaining the solid contents of any prismoid. The calculation from end areas is corrected by tables well arranged and few in number ; and he has all the accuracy of the prismoidal formulæ with scarcely more trouble than in averaging end areas.

H. D. WHITCOMB,

Chief Engineer Chesapeake and Ohio R. R.

E. T. D. MYERS,

Chief Engineer Richmond, Fredericksburg, and Potomac R. R.”

Mowbray's Tri-Nitro-Glycerine.

8vo. Cloth. Illustrated. \$3.00.

TRI-NITRO-GLYCERINE, as applied in the Hoosac Tunnel, and to Submarine Blasting, Torpedoes, Quarrying, etc. Being the result of six years' observation and practice during the manufacture of five hundred thousand pounds of this explosive, Mica Blasting Powder, Dynamites ; with an account of

the various Systems of Blasting by Electricity, Priming Compounds, Explosives, etc., etc. By GEORGE M. MOWBRAY, Operative Chemist, with thirteen illustrations, tables, and appendix. Third Edition. Re-written.

Wanklyn's Milk Analysis.

12mo. Cloth. \$1.00.

MILK ANALYSIS. A Practical Treatise on the Examination of Milk, and its Derivatives, Cream, Butter and Cheese. By J. ALFRED WANKLYN, M. R. C. S.

Toner's Dictionary of Elevations.

8vo. Paper, \$3.00. Cloth, \$3.75.

DICTIONARY OF ELEVATIONS AND CLIMATIC REGISTER OF THE UNITED STATES. Containing, in addition to Elevations, the Latitude, Mean Annual Temperature, and the total Annual Rain Fall of many localities; with a brief Introduction on the Orographic and Physical Peculiarities of North America. By J. M. TONER, M. D.

Adams. Sewers and Drains.

(*In Press.*)

SEWERS AND DRAINS FOR POPULOUS DISTRICTS. Embracing Rules and Formulas for the Dimensions and Construction of Works of Sanitary Engineers. By JULIUS W. ADAMS, Chief Engineer of the Board of City Works, Brook¹u.

SILVER MINING REGIONS OF COLORADO, with some account of the different Processes now being introduced for working the Gold Ores of that Territory. By J. P. WHITNEY. 12mo. Paper. 25 cents.

COLORADO: SCHEDULE OF ORES contributed by sundry persons to the Paris Universal Exposition of 1867, with some information about the Region and its Resources. By J. P. WHITNEY, Commissioner from the Territory. 8vo. Paper, with Maps. 25 cents.

THE SILVER DISTRICTS OF NEVADA. With Map. 8vo. Paper. 35 cents.

ARIZONA: ITS RESOURCES AND PROSPECTS. By Hon. R. C. McCORMICK, Secretary of the Territory. With Map. 8vo. Paper. 25 cents.

MONTANA AS IT IS. Being a general description of its Resources, both Mineral and Agricultural; including a complete description of the face of the country, its climate, etc. Illustrated with a Map of the Territory, showing the different Roads and the location of the different Mining Districts. To which is appended a complete Dictionary of THE SNAKE LANGUAGE, and also of the famous Chinook Jargon, with numerous critical and explanatory Notes. By GRANVILLE STUART. 8vo. Paper. \$2.00.

RAILWAY GAUGES. A Review of the Theory of Narrow Gauges as applied to Main Trunk Lines of Railway. By SILAS SEYMOUR, Genl. Consulting Engineer. 8vo. Paper. 50 cents.

REPORT made to the President and Executive Board of the Texas Pacific Railroad. By Gen. G. P. BUELL, Chief Engineer. 8vo. Paper. 75 cents.

Van Nostrand's Science Series.

It is the intention of the Publisher of this Series to issue them at intervals of about a month. They will be put up in a uniform, neat and attractive form, 18mo, fancy boards. The subjects will be of an eminently scientific character, and embrace as wide a range of topics as possible, all of the highest character.

Price, 50 Cents Each.

1.

CHIMNEYS FOR FURNACES, FIRE-PLACES, AND STEAM BOILERS. By R. ARMSTRONG, C. E.

2.

STEAM BOILER EXPLOSIONS. By ZERAH COLBURN.

3.

PRACTICAL DESIGNING OF RETAINING WALLS By ARTHUR JACOB, A. B. With Illustrations.

4.

PROPORTIONS OF PINS USED IN BRIDGES. By CHARLES E. BENDER, C. E. With Illustrations.

5.

VENTILATION OF BUILDINGS. By W. F. BUTLER. With Illustrations.

6.

ON THE DESIGNING AND CONSTRUCTION OF STORAGE RESERVOIRS. By ARTHUR JACOB. With Illustrations.

7.

SURCHARGED AND DIFFERENT FORMS OF RETAINING WALLS. By JAMES S. TATE, C. E.

8.

A TREATISE ON THE COMPOUND ENGINE. By JOHN TURNBULL. With Illustrations.

9.

FUEL. By C. W. SIEMENS to which is appended the Value of Artificial Fuels as compared with Coal. By J. WORMALD, C. E.

10.

COMPOUND ENGINES. Translated from the French of A. MALLET. Illustrated.

-
11.
THEORY OF ARCHES. By Prof. W. ALLAN, of the
Washington and Lee College. Illustrated.
12.
A PRACTICAL THEORY OF VOUSSOIR ARCHES. By
WILLIAM CAIN, C.E. Illustrated.
13.
A PRACTICAL TREATISE ON THE GASES MET
WITH IN COAL-MINES. By the late J. J. ATKINSON,
Government Inspector of Mines for the County of Durham,
England.
14.
FRICTION OF AIR IN MINES. By J. J. ATKINSON,
author of "A Practical Treatise on the Gases met with in
Coal-Mines."
15.
SKEW ARCHES. By Prof. E. W. HYDE, C.E. Illustrated
with numerous engravings and three folded plates.
16.
A GRAPHIC METHOD FOR SOLVING CERTAIN AL-
GEBRAIC EQUATIONS. By Prof. GEORGE L. VOSE.
With illustrations.
17.
WATER AND WATER SUPPLY. By Prof. W. H. COR-
FIELD, M.A., of the University College, London.
18.
SEWERAGE AND SEWAGE UTILIZATION. By Prof.
W. H. CORFIELD, M.A., of the University College, London.
19.
STRENGTH OF BEAMS UNDER TRANSVERSE
LOADS. By Prof. W. ALLAN, author of "Theory of
Arches." With illustrations.

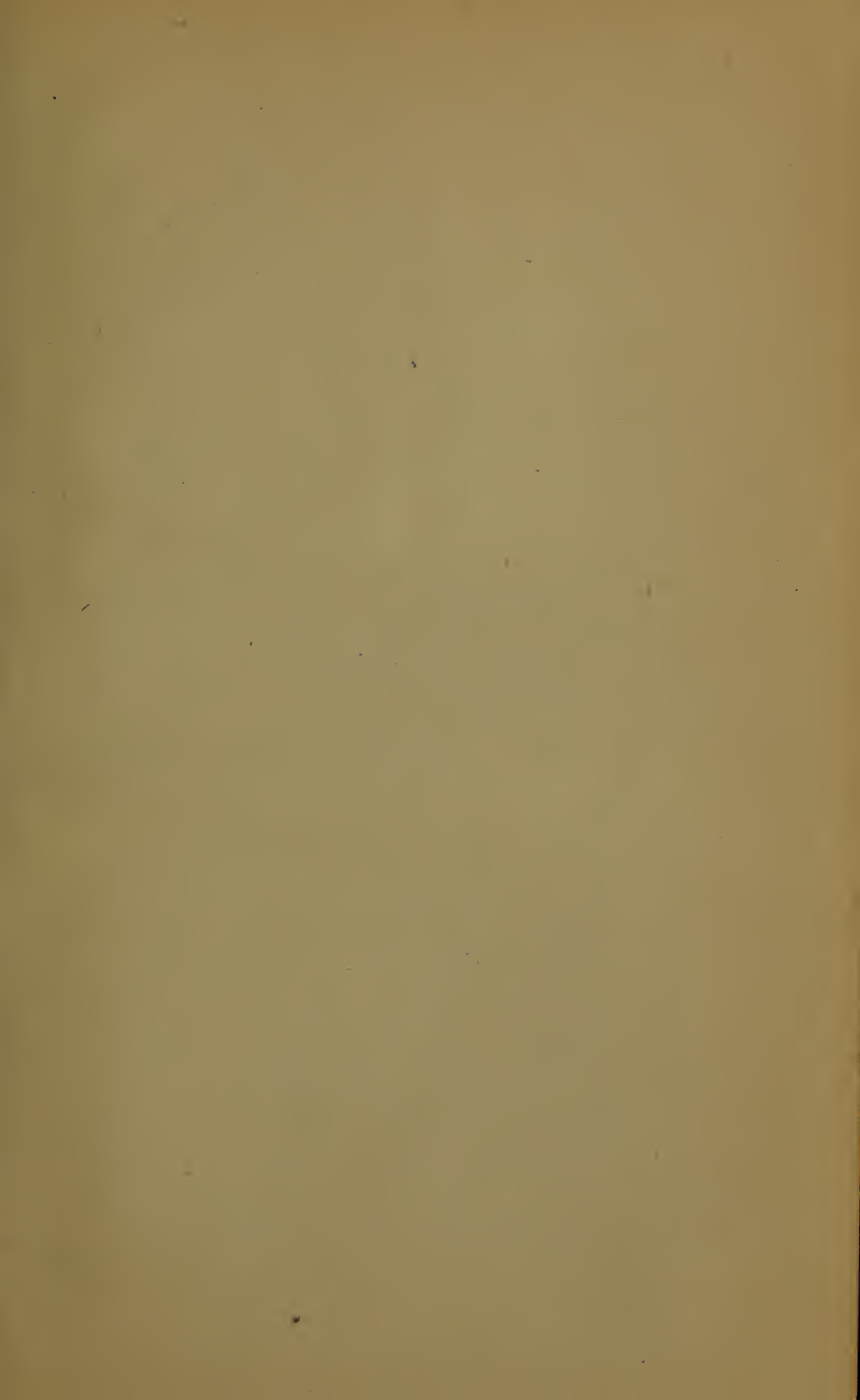

Author Axon, William E. A.

The

T:

Title Mechanics friend A971

LIBRARY
NAVY DEPARTMENT
Room 2730

*Books must be returned within
two weeks*

LIBRARY OF CONGRESS

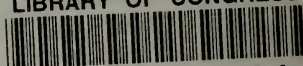

0 030 005 091 8