

萬 有 文 庫

第一集一千種

王 雲 五 主 編

營 造 法 式

(七)

李 誠 編 修

商 務 印 書 館 發 行



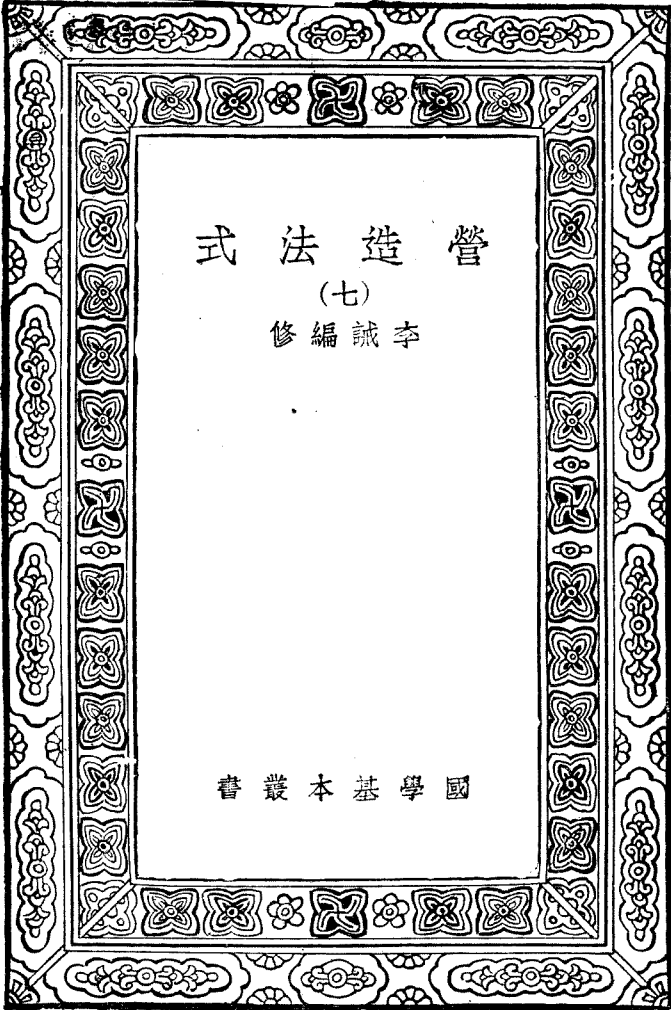

營 造 法 式

(七)

李 誠 編 修

國 學 基 本 叢 書

營造法式卷第三十一

通直郎管修葺皇第外第專提舉修葺班直諸軍營房等臣李誠奉

聖旨編修

大木作制度圖樣下

殿閣地盤分槽等第一

殿堂等八鋪作副階六鋪作

雙槽斗底槽準此草架

側樣第十一

殿堂等七鋪作副階五鋪作

雙槽草架側樣第十二

殿堂等五鋪作副階四鋪作

單槽草架側樣第十三

殿堂等六鋪作分心槽草架側樣第十四

廳堂等自十架椽至四架椽間縫內用梁柱第十五

大木作制度圖樣下

殿閣地盤分槽等第十

殿間身地盤九間分心斗底槽

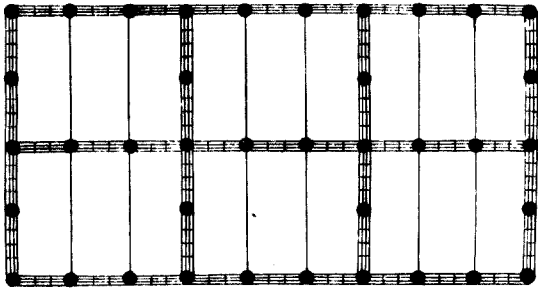

殿閣地盤殿身七間副階周市
各兩架樣身內金箱斗底槽

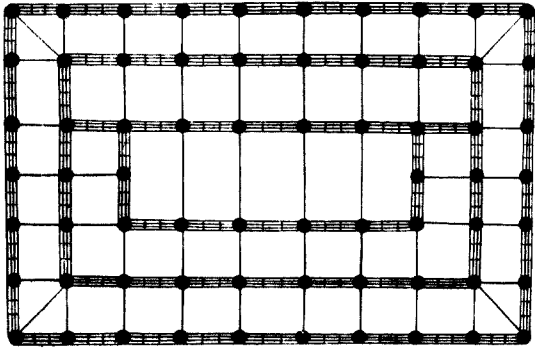

殿閣地盤殿身七間副階
周市各兩架椽身內單槽

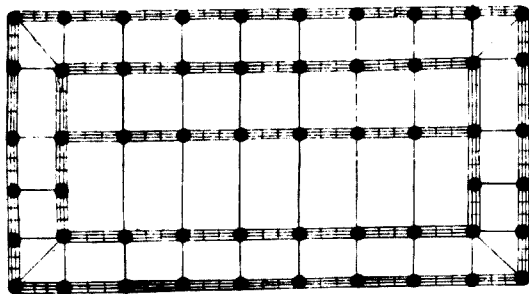

殿閣地盤殿身七間副階
周市各兩架椽身內雙槽

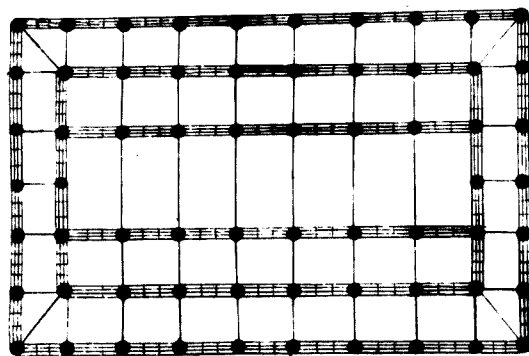

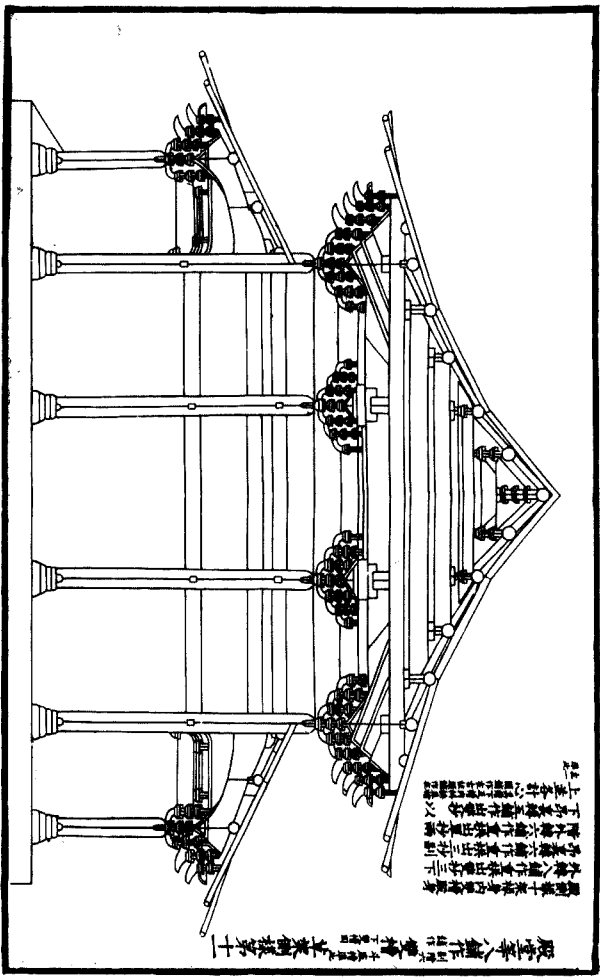

殿宇八鋪作制
作制詳見下章
 十一 某東閣樣

閣單十架椽身內置椽身
 於椽八鋪作重椽出三抄
 下
 椽椽六鋪作重椽出三抄
 椽椽六鋪作重椽出三抄
 以下各椽重椽作重椽出三抄
 以上各椽八鋪作重椽出三抄

殿堂亭子鋪作別置檼槽梁架側樣第十二

殿制以十架椽身向受椽身
 外柱上鋪作置檼出脊抄兩下
 內柱身於鋪作置椽出抄割
 隙中於柱鋪作置椽出抄單
 即於柱身鋪作出抄 以上
 並各計心

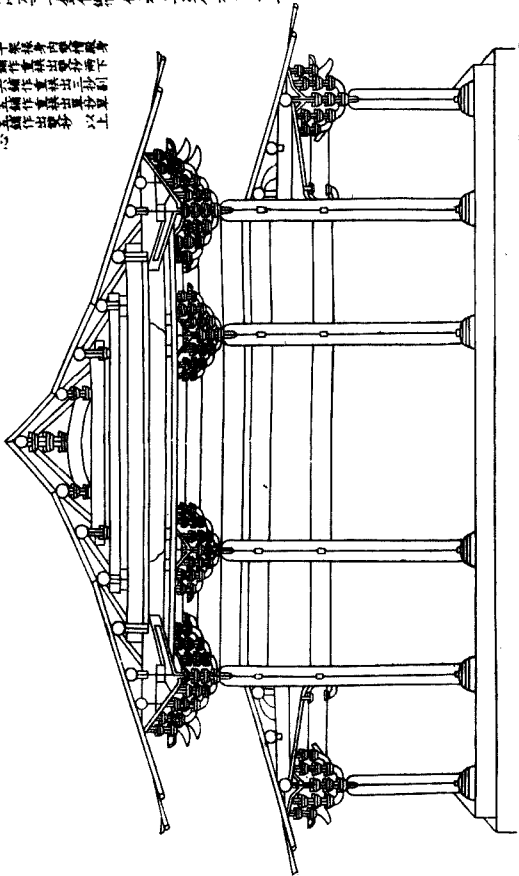

殿宇五鋪作斗栱斗栱架側樣第十三

殿宇五鋪作斗栱斗栱架側樣第十三
殿宇五鋪作斗栱斗栱架側樣第十三
殿宇五鋪作斗栱斗栱架側樣第十三
殿宇五鋪作斗栱斗栱架側樣第十三
殿宇五鋪作斗栱斗栱架側樣第十三
殿宇五鋪作斗栱斗栱架側樣第十三
殿宇五鋪作斗栱斗栱架側樣第十三
殿宇五鋪作斗栱斗栱架側樣第十三
殿宇五鋪作斗栱斗栱架側樣第十三
殿宇五鋪作斗栱斗栱架側樣第十三

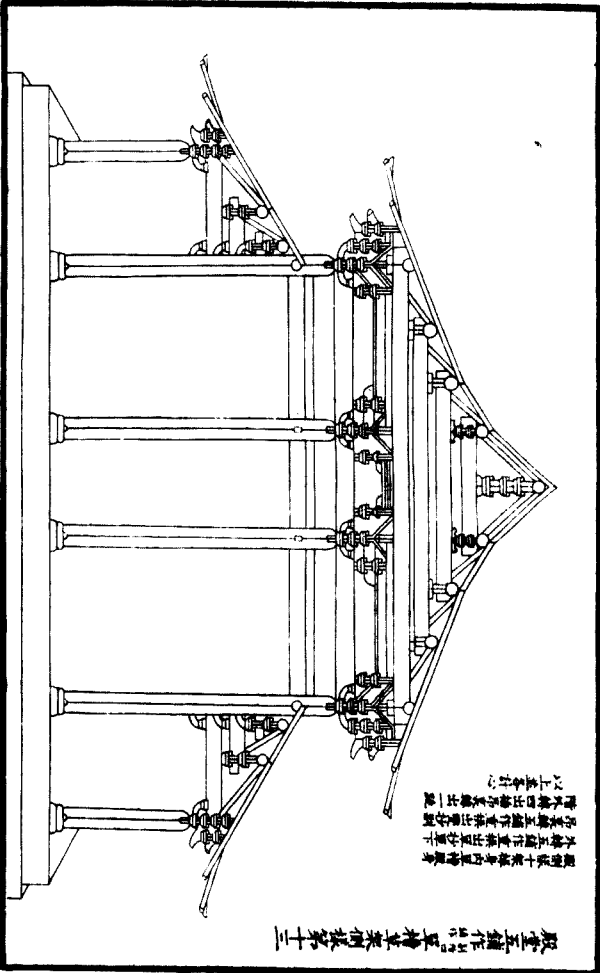

殿宇等六鋪作分心槽柱架側樣第十四

殿宇等六鋪作分心槽柱架側樣第十四
殿宇等六鋪作分心槽柱架側樣第十四
殿宇等六鋪作分心槽柱架側樣第十四
殿宇等六鋪作分心槽柱架側樣第十四
殿宇等六鋪作分心槽柱架側樣第十四

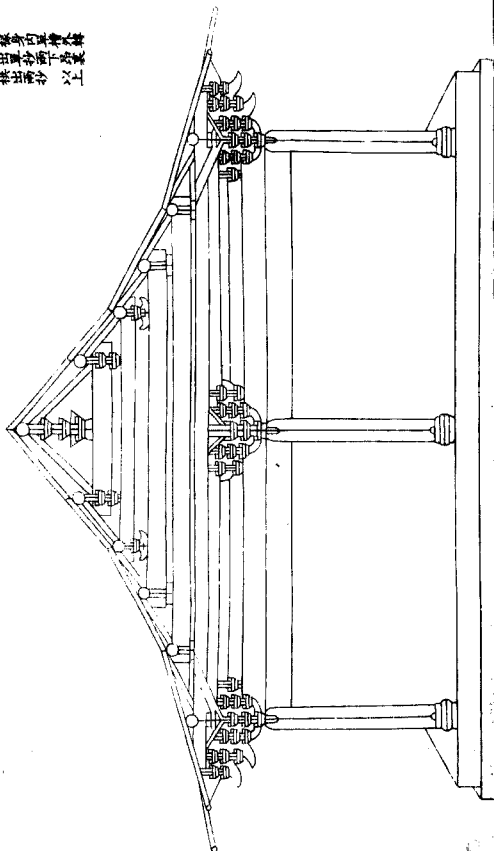

十架棟架之二柱

鳳臺寺自十架棟架內用梁柱第十五

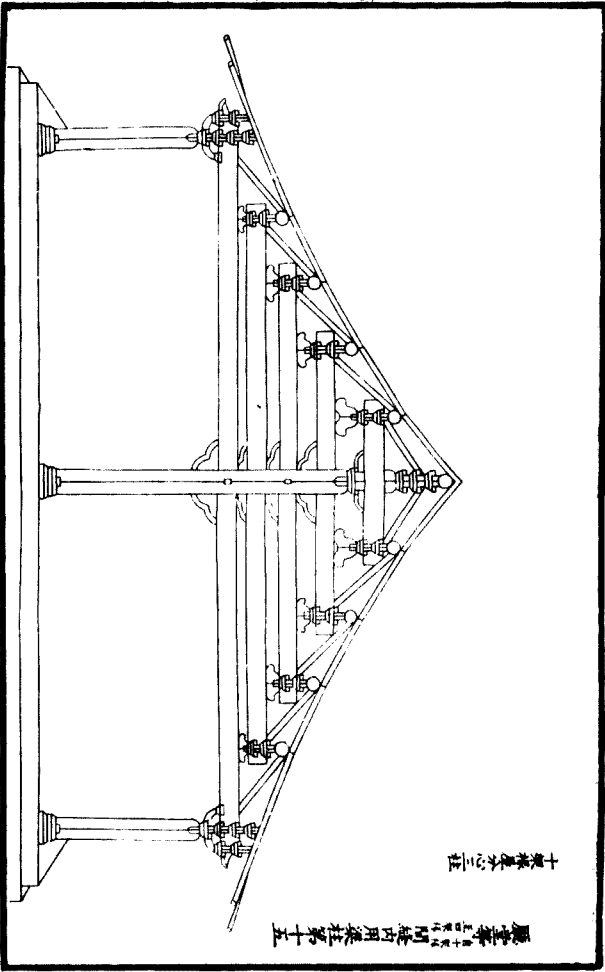

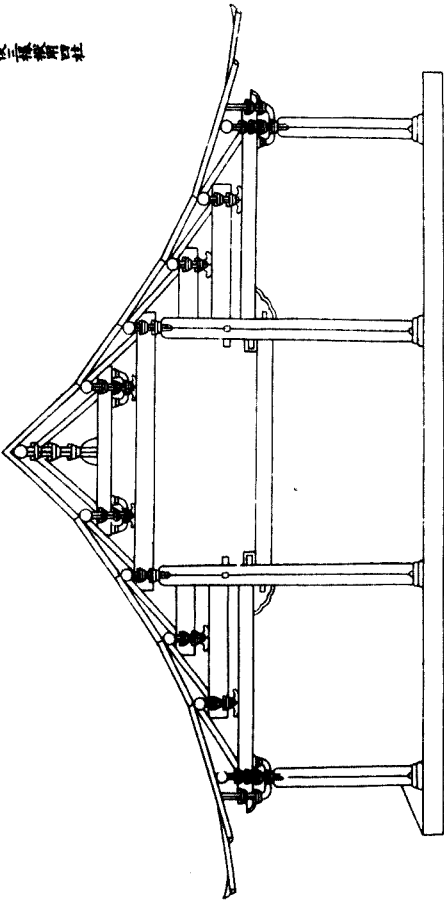

十架梁前後三椽殿四柱

十架椽屋分前椽孔椽五柱

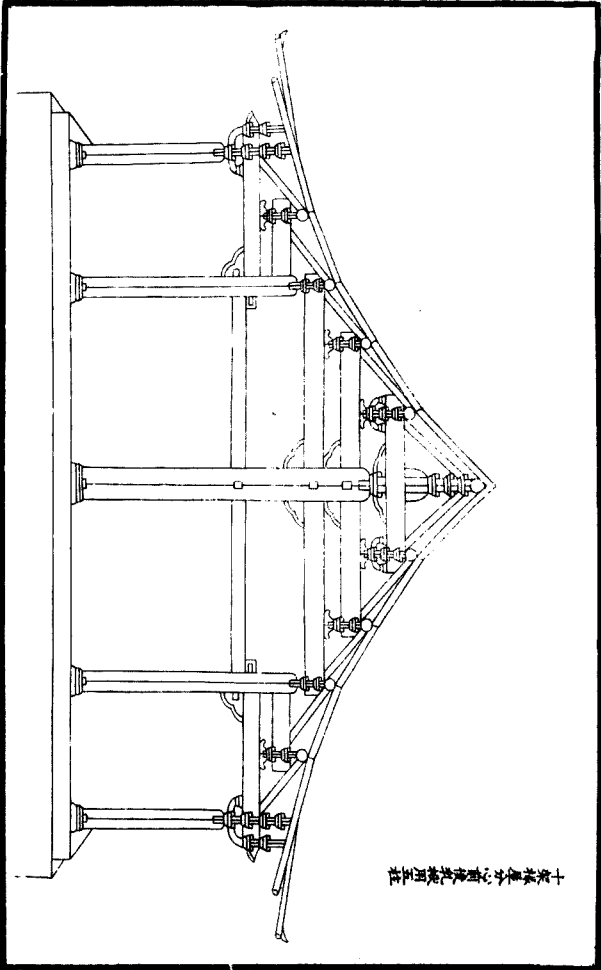

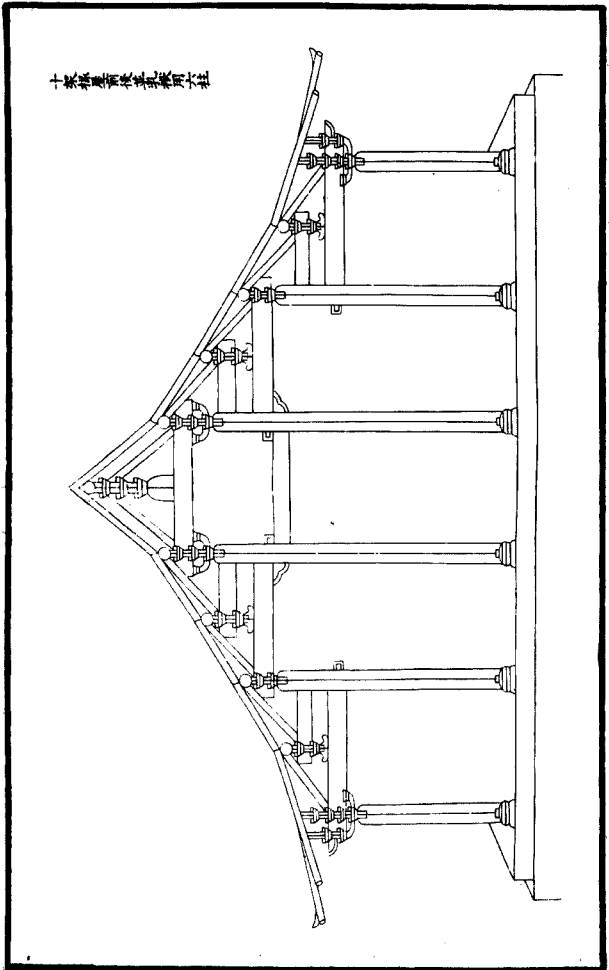

十等分前後各到穿孔採用在柱

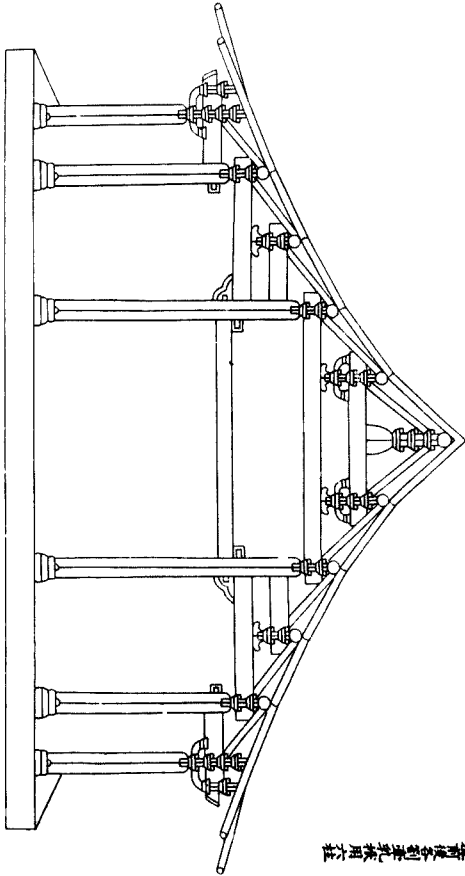

三層分層屋椽

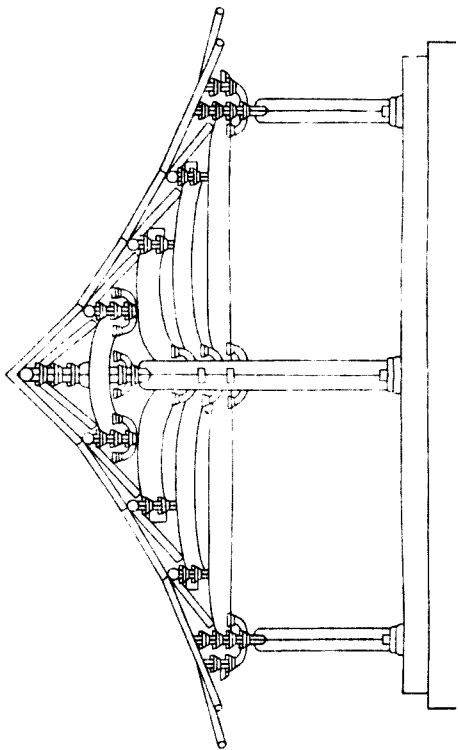

八寶樓屋孔狀對六椽用二柱

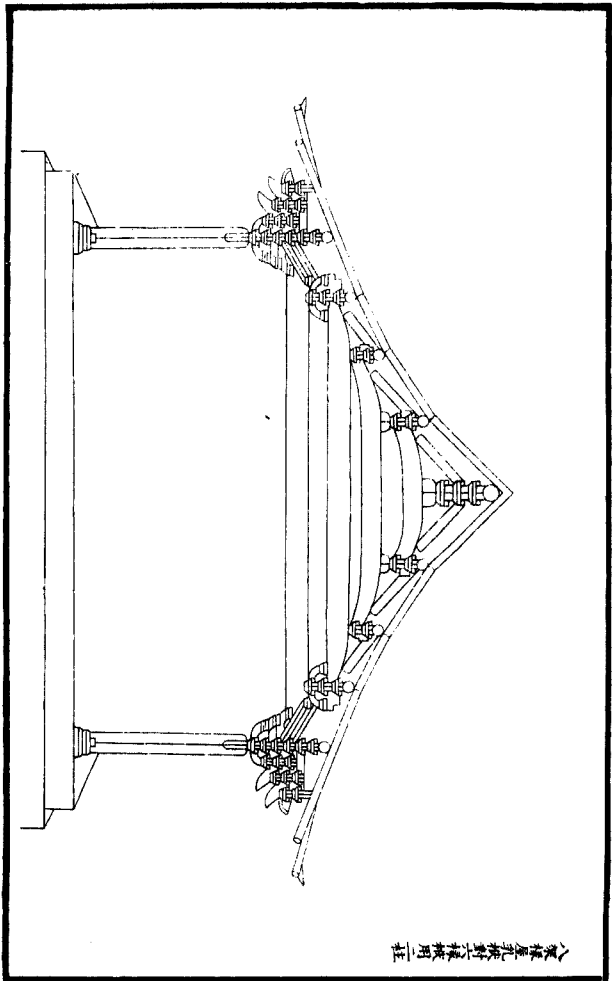

八 架椽前後界板四柱

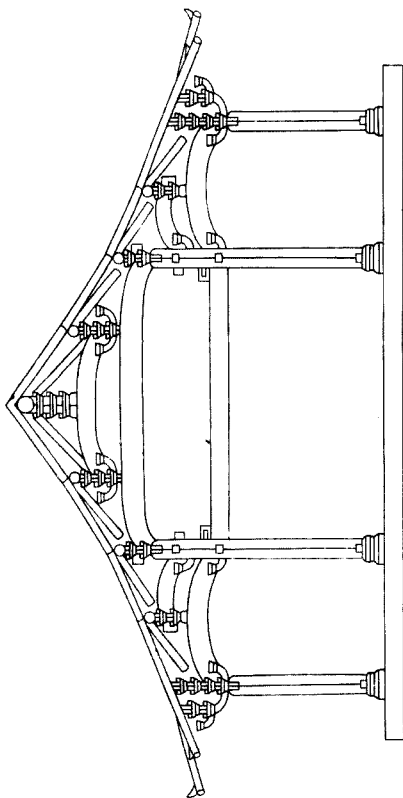

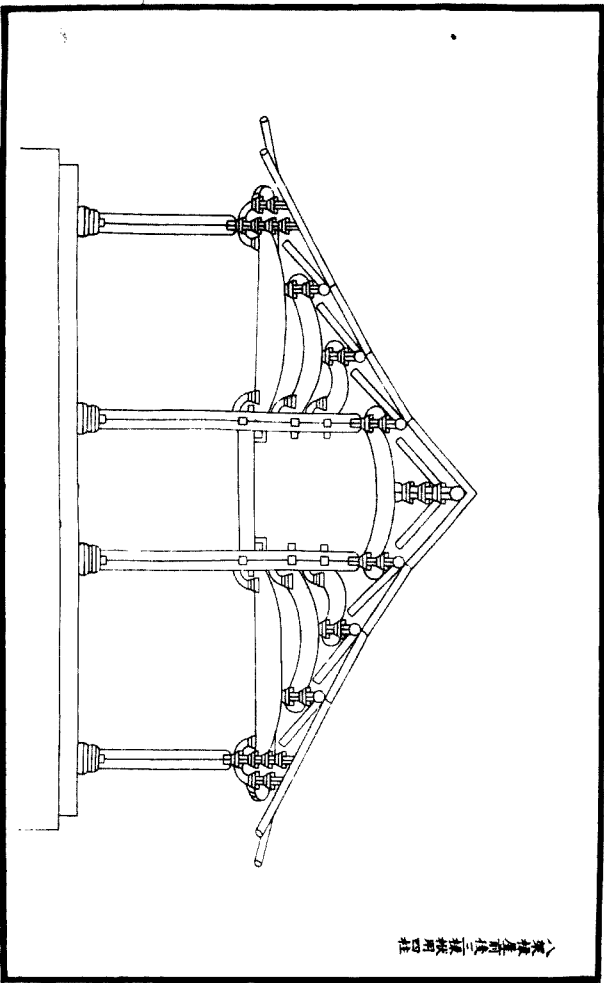

八架檼屋脊心椽用五柱

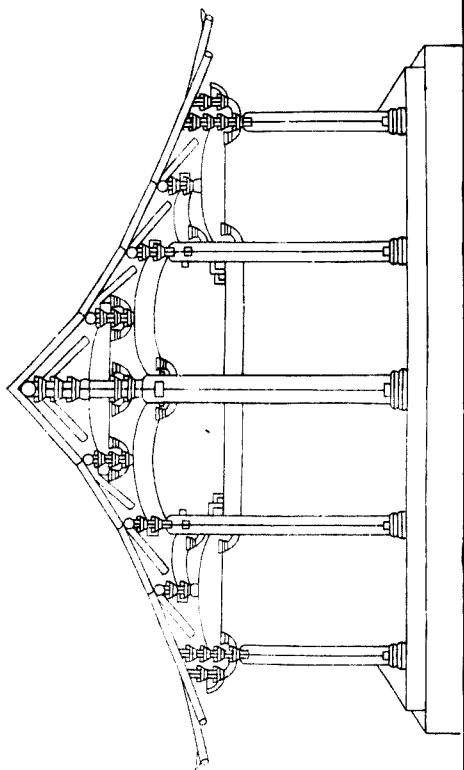

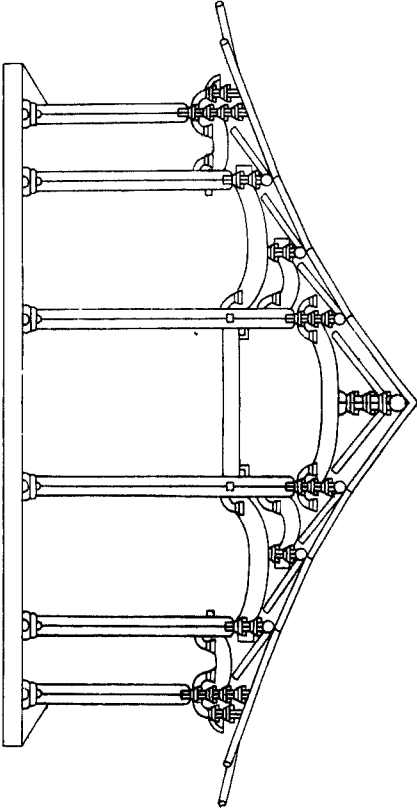

大塚屋前傳の常用大柱

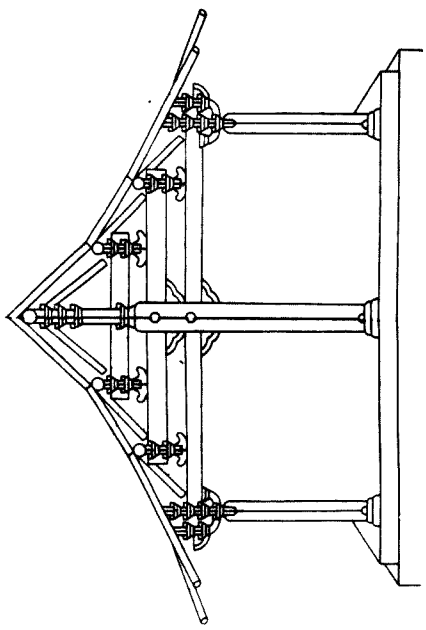

六椽屋不用三柱

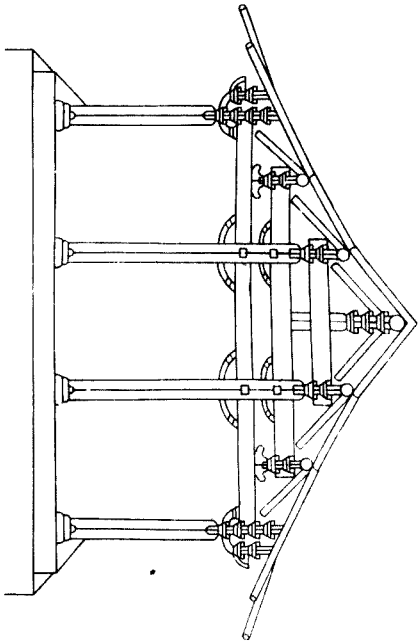

六等屋脊椽椽制基用四柱

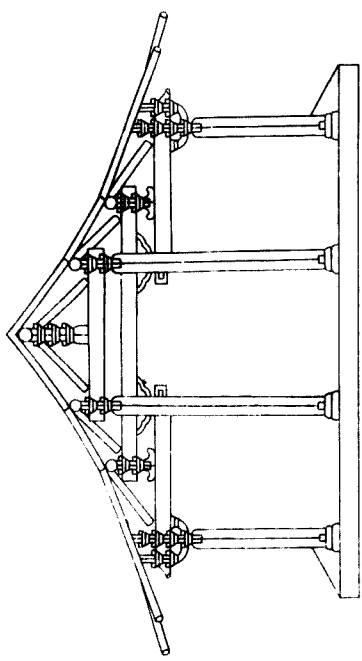

四架椽屋分心用三柱

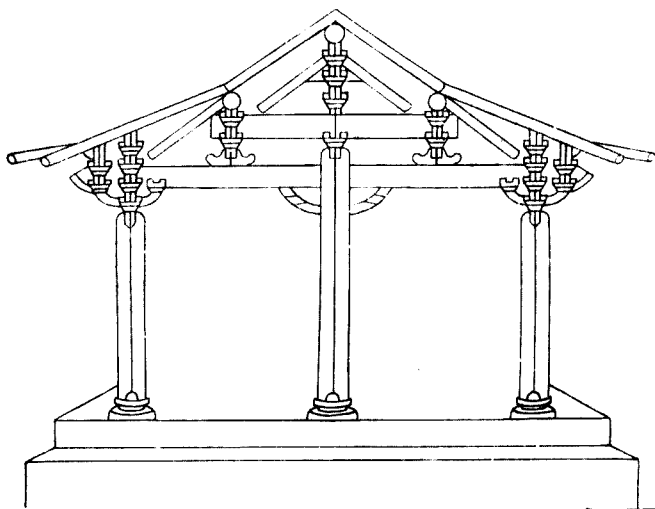

四架椽屋劉牽二椽拱用三柱

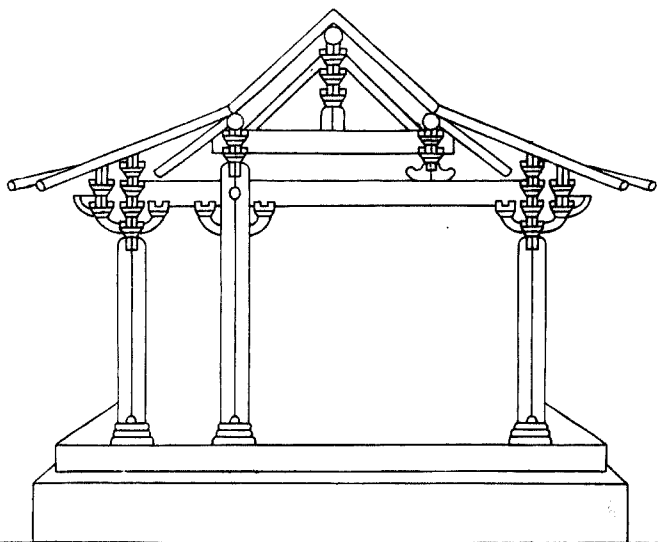

四架椽屋分心剎牽用四柱

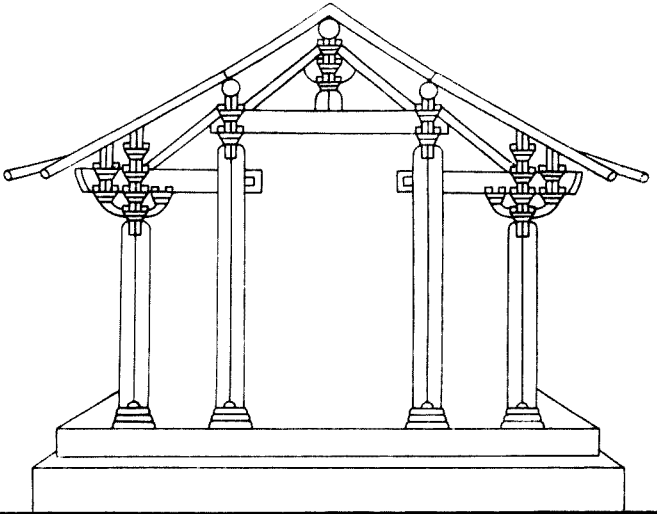

四架椽屋通檐用二柱

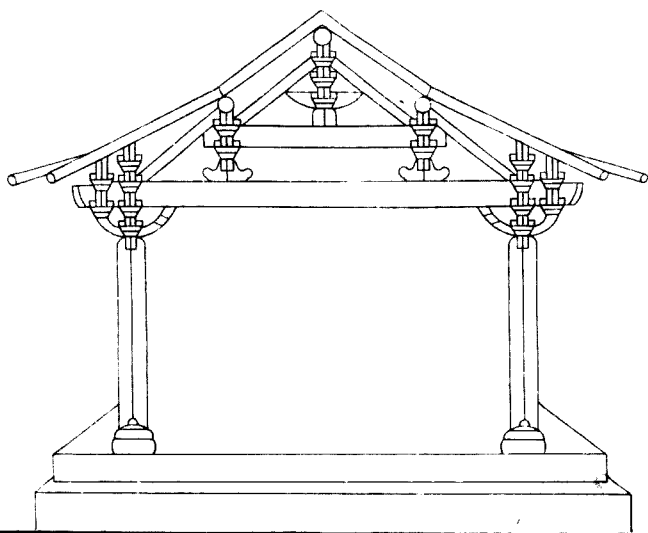

營造法式卷第三十一

殿閣地盤分槽第十

殿閣身地盤九間
身内分斗底槽

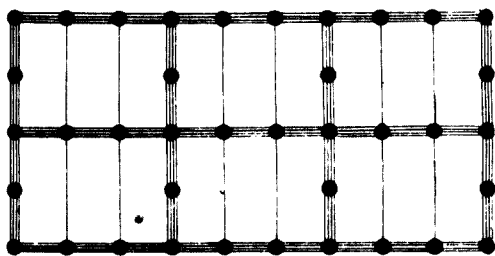

殿閣地盤殿身七間副階周市
各兩架椽身内金箱斗底槽

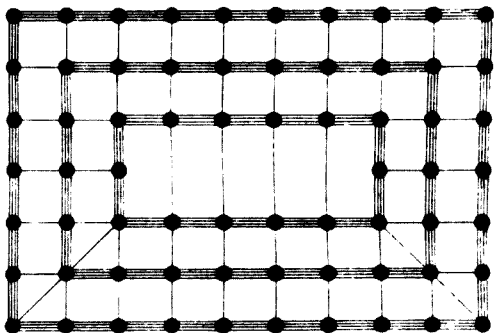

殿間地盤殿身七間副階
周市各兩椽身內單槽

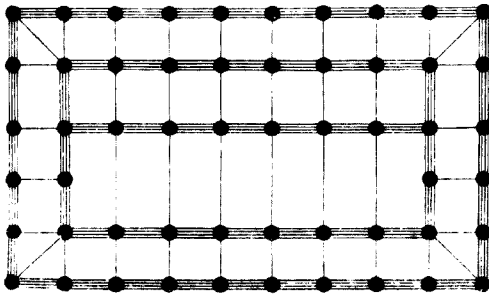

殿間地盤殿身七間副階
周市各兩椽身內雙槽

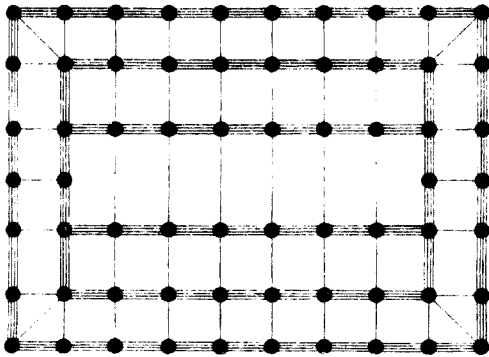

嚴密入銷作時應備井其得在 草架倒模第十

取重備料七彩星標帶上備材料十彩星標亦亦全註材料五標十彩
 大聚料者凡以口全定之知行三而材料口分六除至柱徑二尺
 十材料口亦不其而大之而物同柱徑大於其柱徑之五厚以備
 之加三至其及之要其作以二或或或
 備料口分定五而口亦不其而
 備料口分定五而口亦不其而
 者以料口分定五而口亦不其而
 而只料標數之更不復
 更不復者不須分以五數七
 備依其傳及柱之更不
 備五數明備者加而
 備只于若于由大木料
 柱相得之標徑

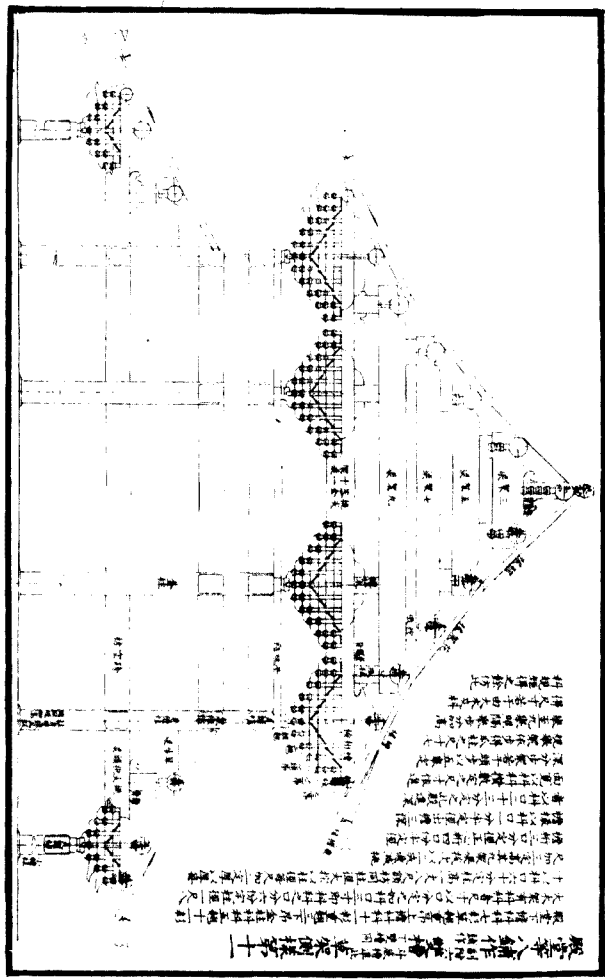

殿堂等七鋪作別屋脊架側樣第十二

殿堂等木十一架梁樣式斜口三寸定規上構料料九彩量高
 下昂下構料五彩量起二下昂木九架梁上有一部分現定
 七架梁此做法式樣名為伏梁架部大木高量理及料料薄量出
 彩料口為五夫木定料規距及料料各目均詳量數三十

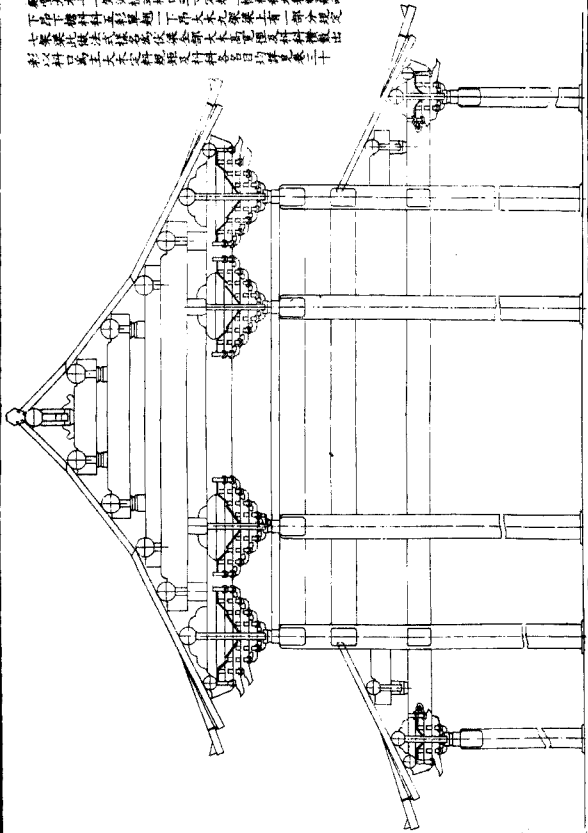

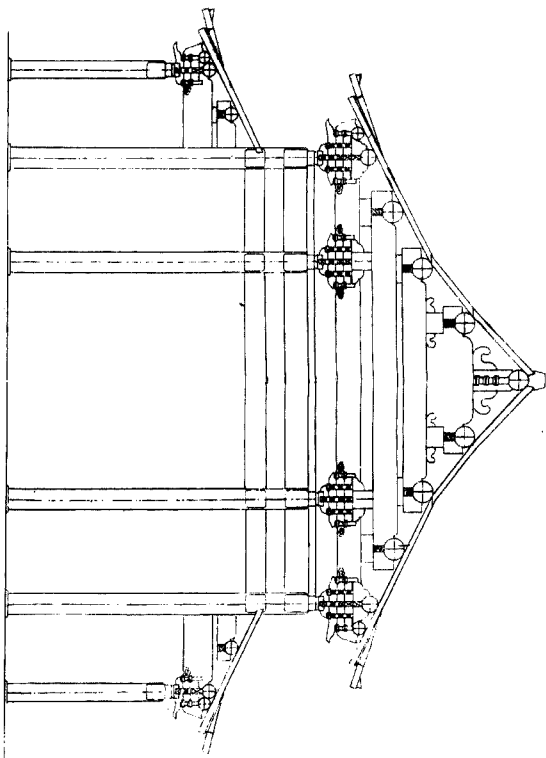

殿五鋪作銅作單檁屋架側樣第十三

殿五鋪作銅作單檁屋架側樣第十三
 殿五鋪作銅作單檁屋架側樣第十三
 凡木架料做件口均用字音材料標明註見第一節

殿堂六鋪作分槽基架側樣第十四

殿堂第十四本木十二架梁材十寸其地斷一斗兼出兩頭一斗大木定料料理
定料料大小若干及條材總數出形均詳見象字

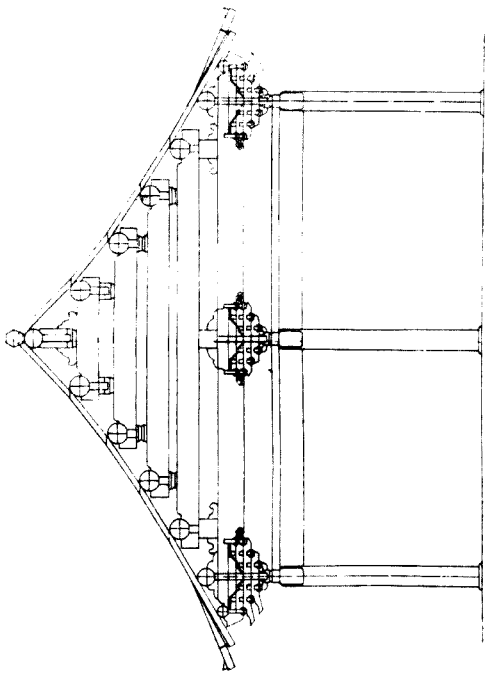

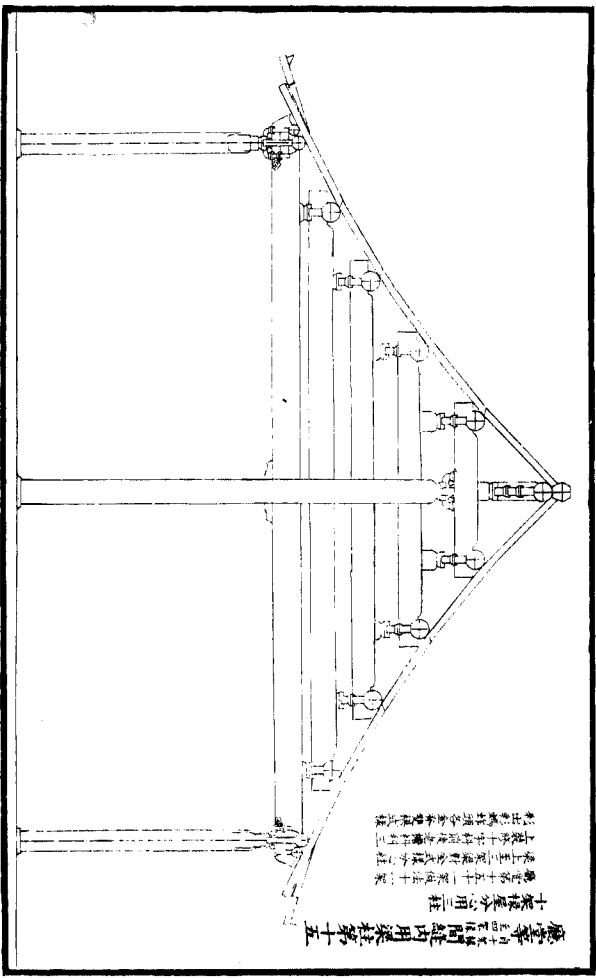

歇山等角十架椽間縫內用梁柱第十五

十架椽屋分用柱

歇山第十五架椽式樣分柱

歇山至三架椽式樣分柱

上歇山十架椽式樣分柱

斜出歇山式樣分柱

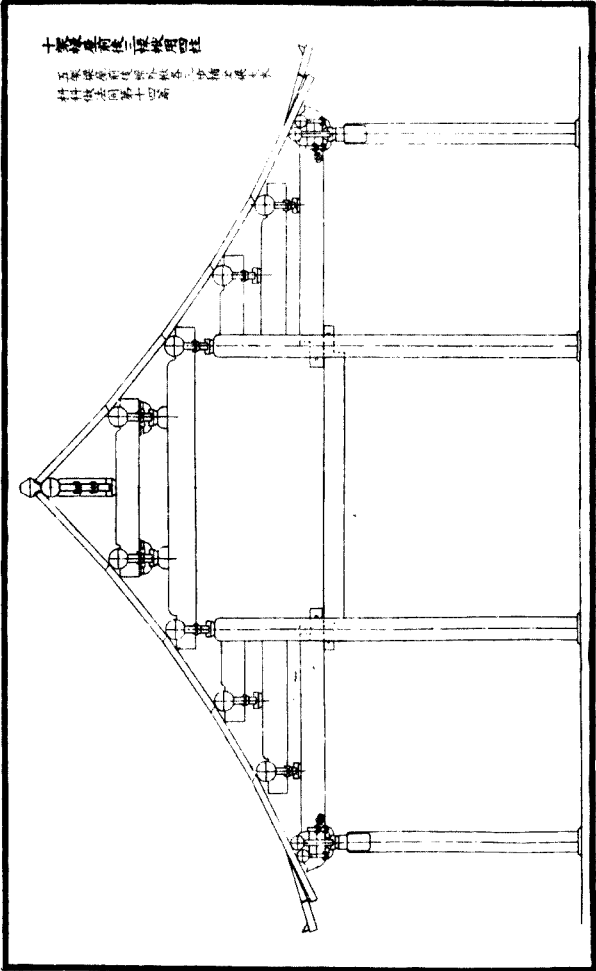

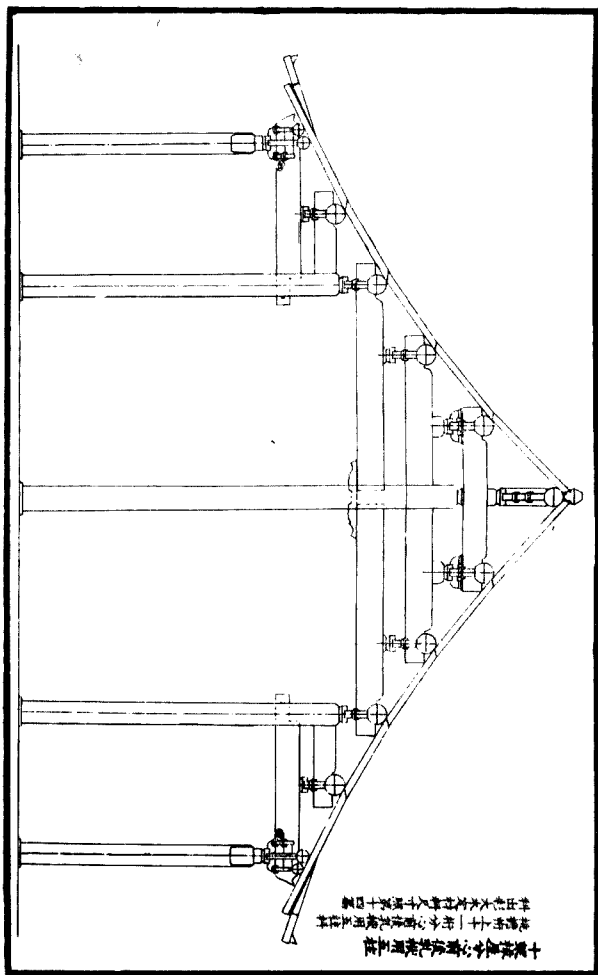

十架樓屋前樓空架用柱
 梁架柱十一種畫料出影大木
 梁架柱十種第十四圖

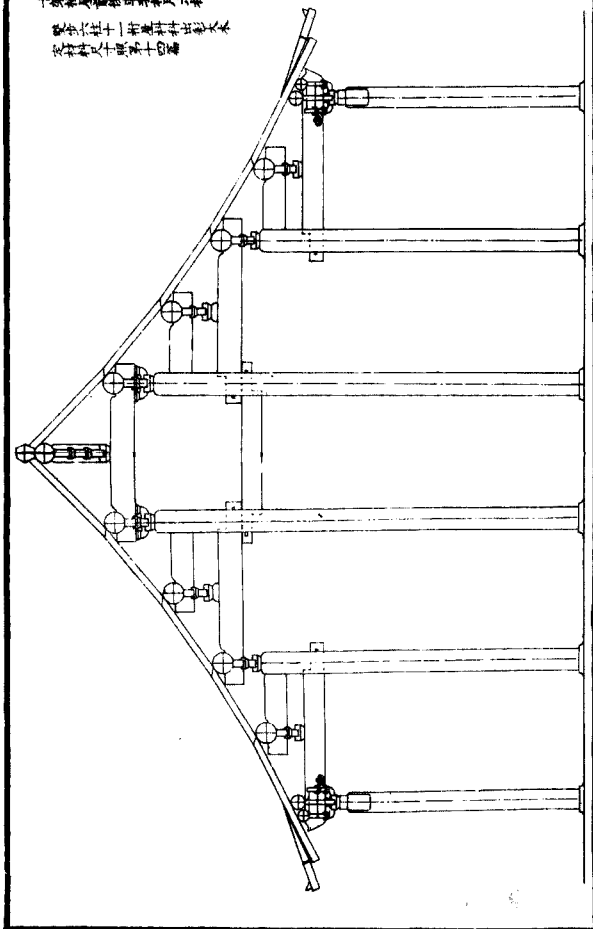

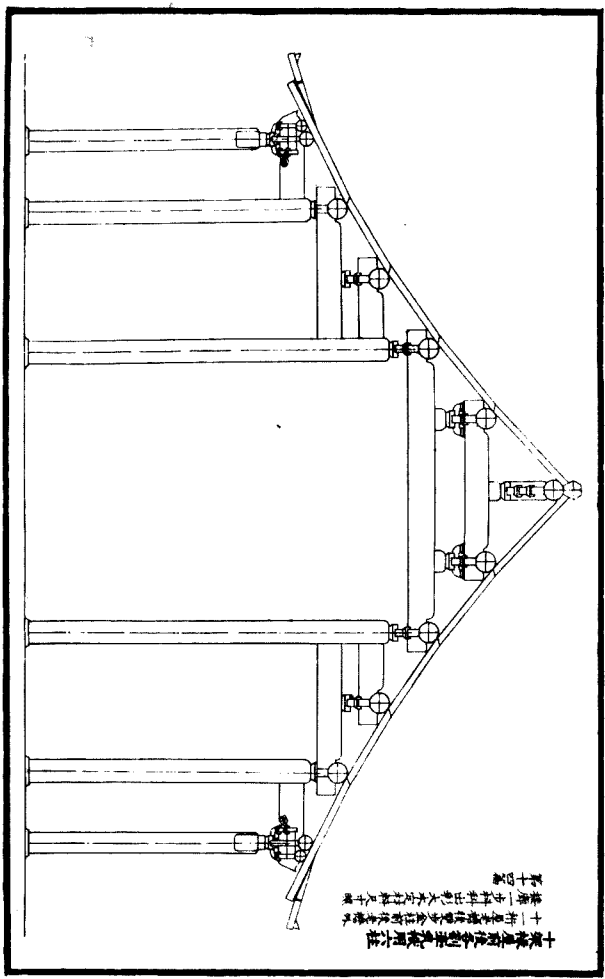

十架樓屋後收剝架用六柱
十一桁架樓後收剝架用六柱
第十二層
第十三層
第十四層

合榱屋脊用三柱

凡屋脊上合榱者，其屋脊上十字形，亦
有榱頭，其形與屋脊上十字形各部
各名目詳見卷三十一

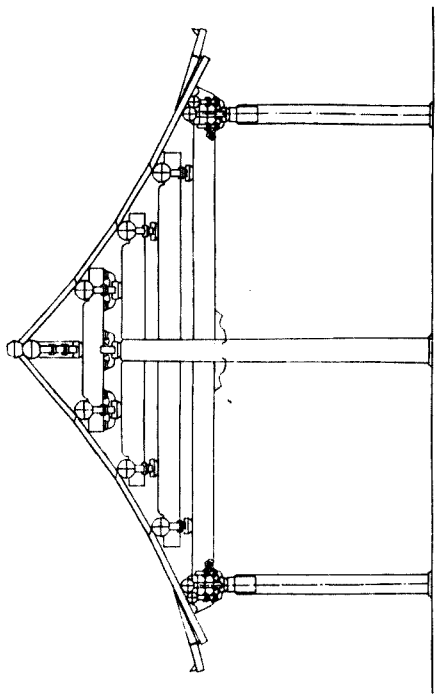

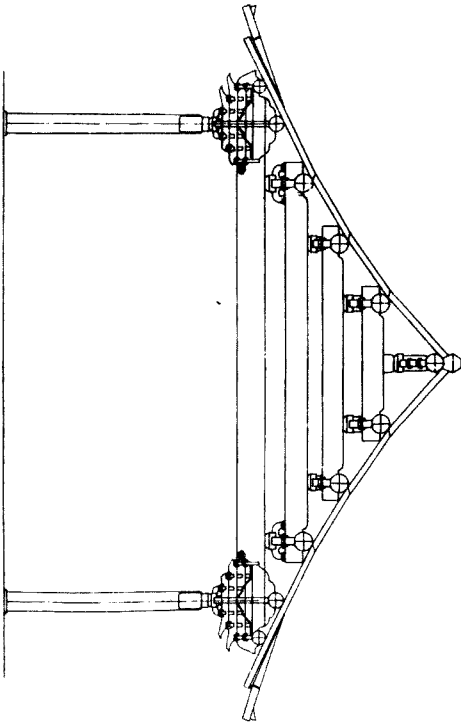

八號管架機對六機所用一柱
 心機運度大類由五機之說又事十
 與字樣見二十頁機字林材料
 至機序存畫出一套而頭各機各形
 各機之俗名亦詳見三十

八 檼屋脊椽椽用程

凡檼屋脊椽椽分抽金椽去遠至五椽遠至兩步
 俗名跨空椽椽小椽柱料三彩內部各處皆然
 總注三椽遠至出對為十步

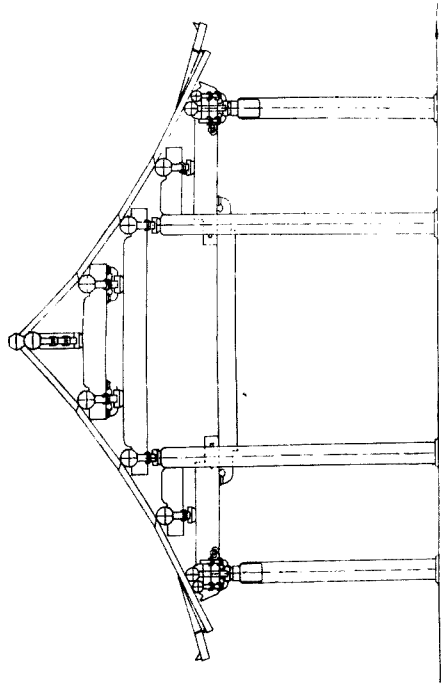

八、椽架前後三椽架用柱
 九、椽架前後三椽架用柱
 十、椽架前後三椽架用柱
 十一、椽架前後三椽架用柱
 十二、椽架前後三椽架用柱

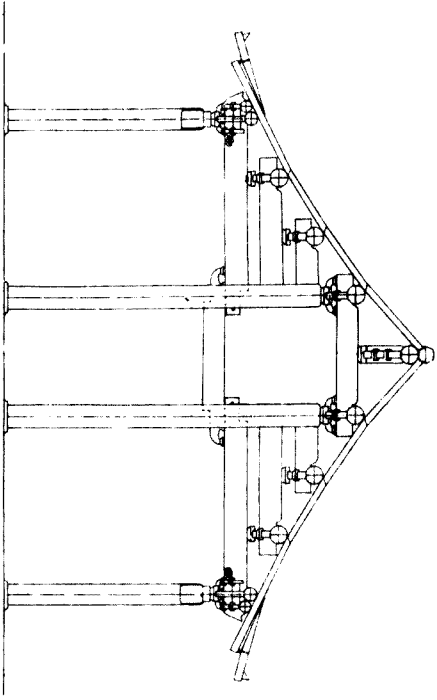

八角殿五柱

八角殿五柱之結構用五柱前後三對
柱之梁架上面出於十字樑

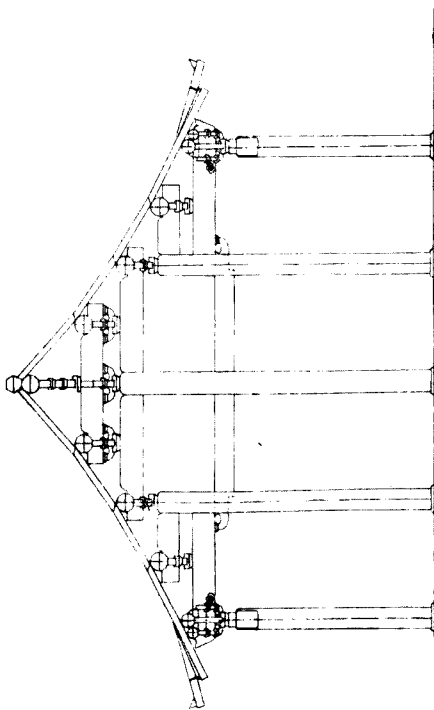

ノ家賃前傳制器其七紐
 之家賃運送之紐前傳器用三形柱

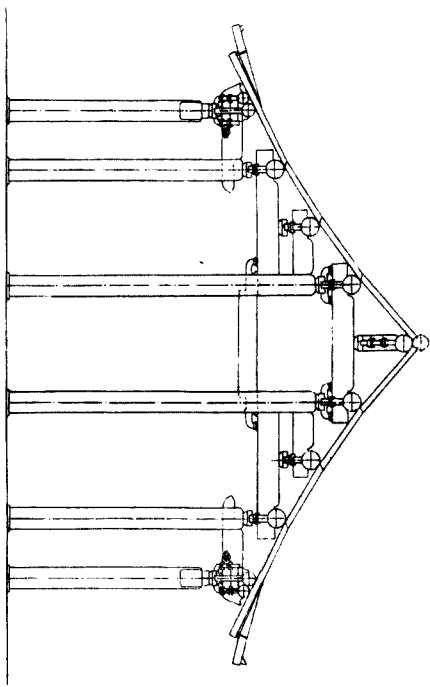

六椽殿木心用柱

七椽殿木心三椽下斜金銀法金心三柱間樓
樓三柱斜金木心柱七椽殿內身或七椽正
坊以他名號文架

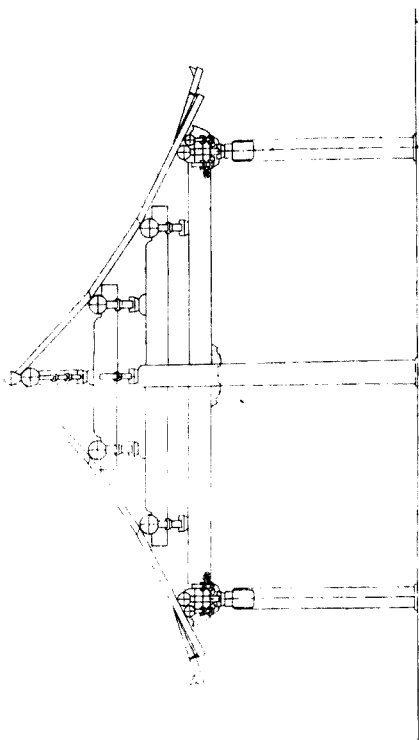

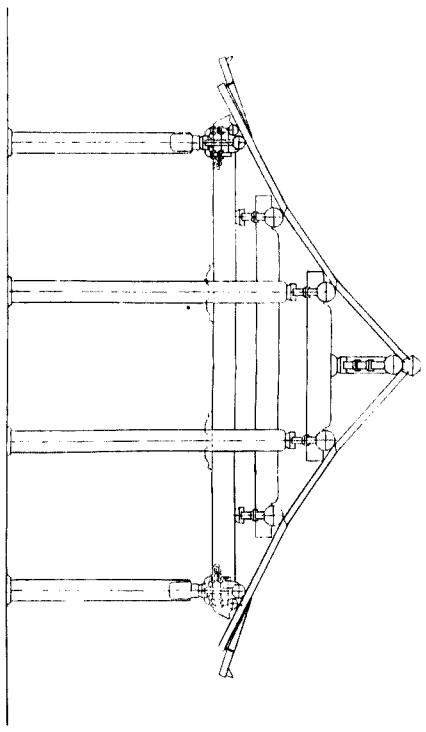

大梁屋架乳栱對四椽椽用柱
七架梁四柱做法同後圖材料三彩

本圖係根據機械製圖的標準

繪製而成

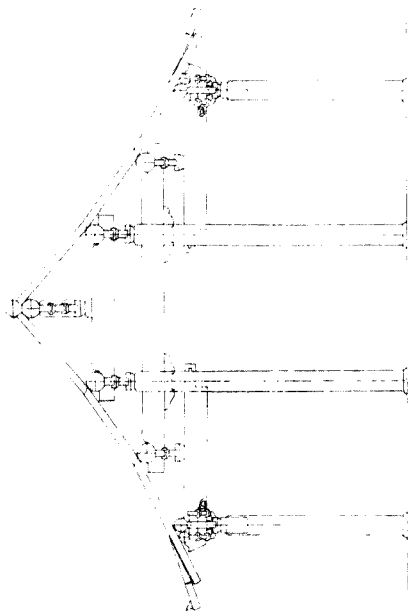

管
道
法
式

七

卷
三
十
一
附

四
十
八

四架椽屋分心用三柱

大木架五桁掛料五架梁對金做法前後
檐料料三彩翹上內出蘇葉頭外出螞蚱
頭金脊掛料料瓜拱萬拱之分位法式

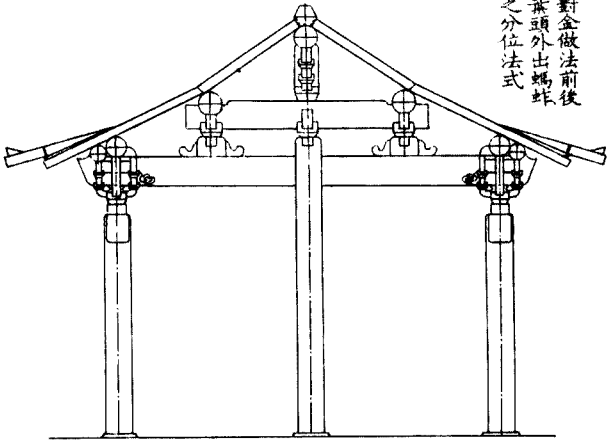

四架椽屋劄率二椽椽用三柱

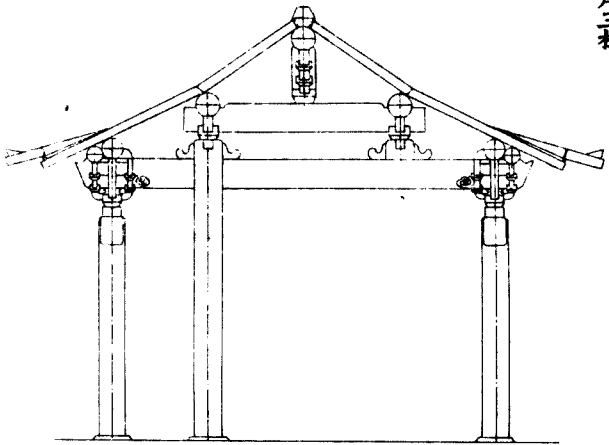

四架椽屋分心割牽用四柱

大木架三架梁做法前後檐廊架一步
料科同第二十篇

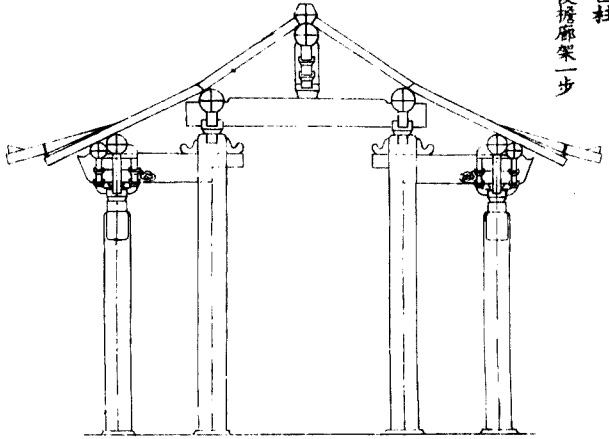

四架椽屋通檐用二柱

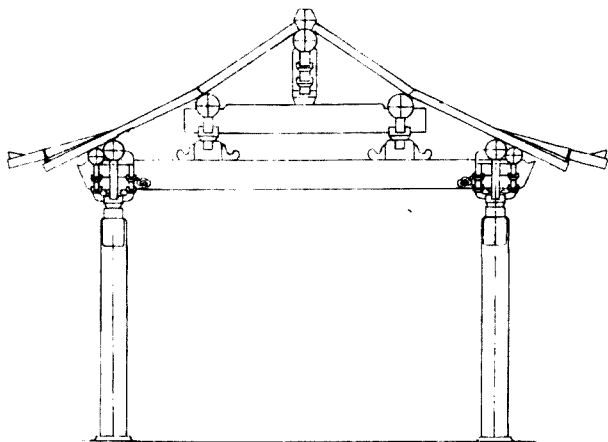

此為卷三十四彩畫作制度圖樣料柱全式
 之一梁椽飛子同 標影正可以因神創畫而木架
 今皆略其附圖二篇以明之

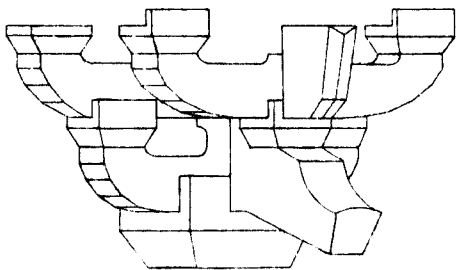
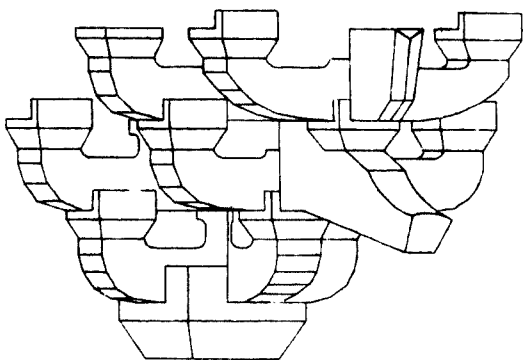

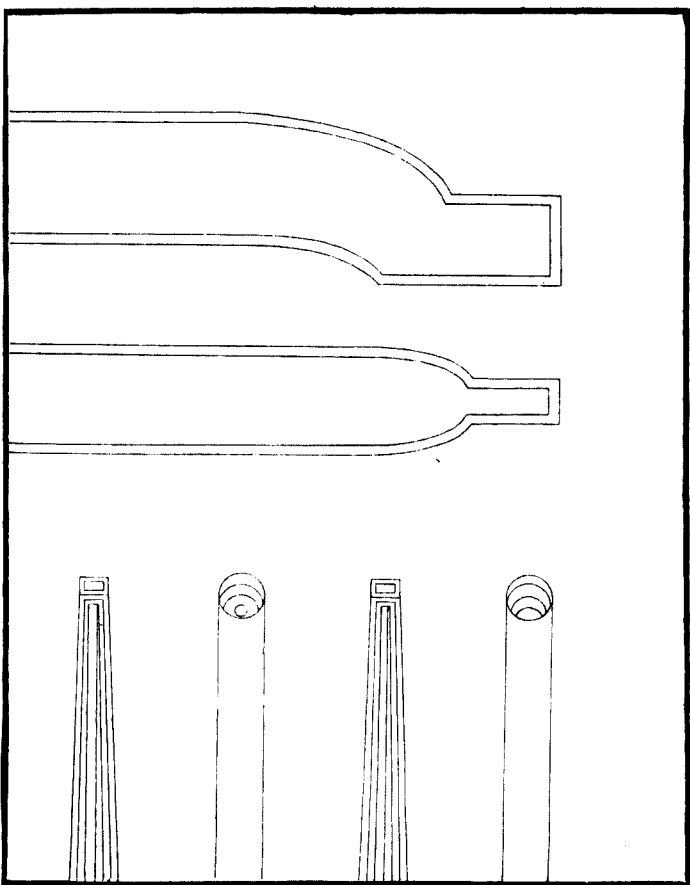

此為卷三十四彩畫作制度圖樣
料拱合式之二梁樣飛子同

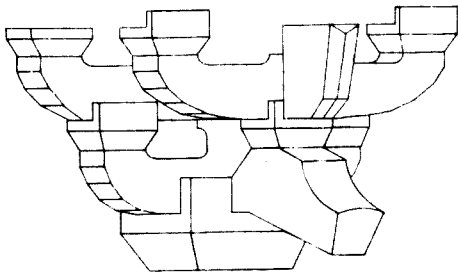
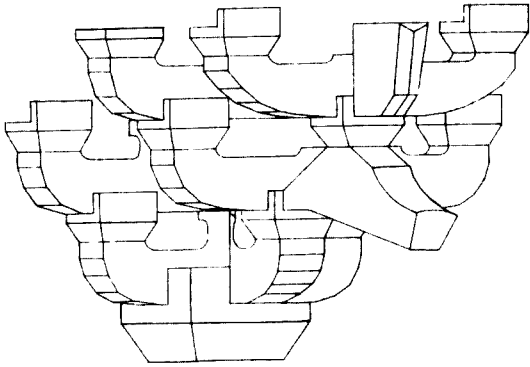

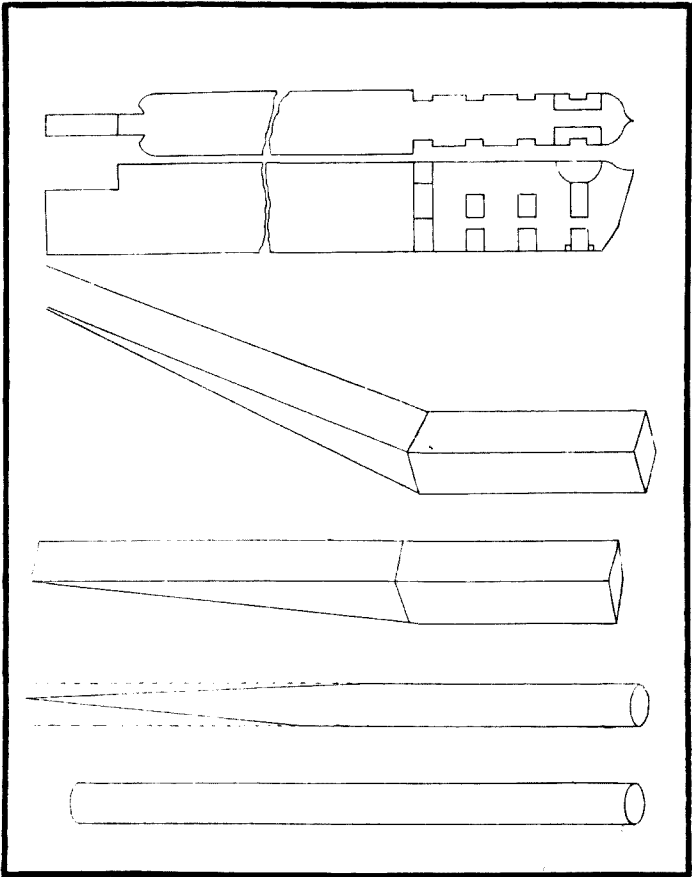

營造法式卷第三十一附

深州賀新賡秦渭濱圖說

武進劉南策影繪

黃岡饒星舫繕寫

營造法式卷第三十二

通直郎管修葺皇第外第專提舉修葺班直諸軍營房等臣李誠奉

聖旨編修

小木作制度圖樣

門窗格子門等第一

垂魚附

平棊鉤闌等第二

殿閣門亭等牌第三

佛道帳經藏第四

雕木作制度圖樣

混作第一

拱眼內彫插第二

格子門等腰華版第三

平基華盤第四

雲拱等雜樣第五

小木作制度圖樣

門窗格子門等第一附

版門

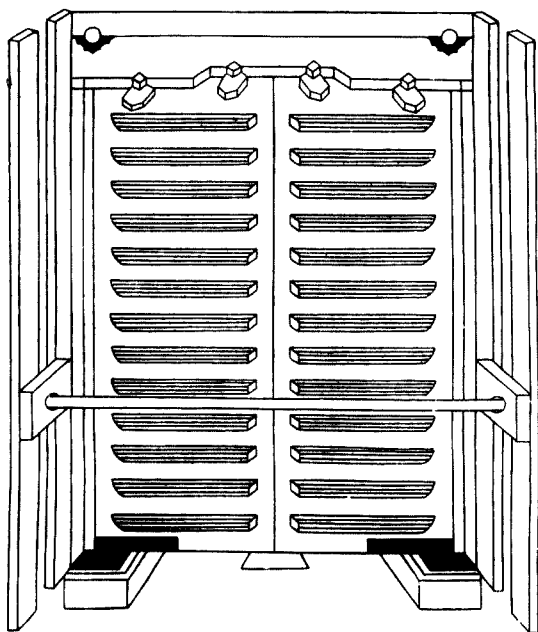

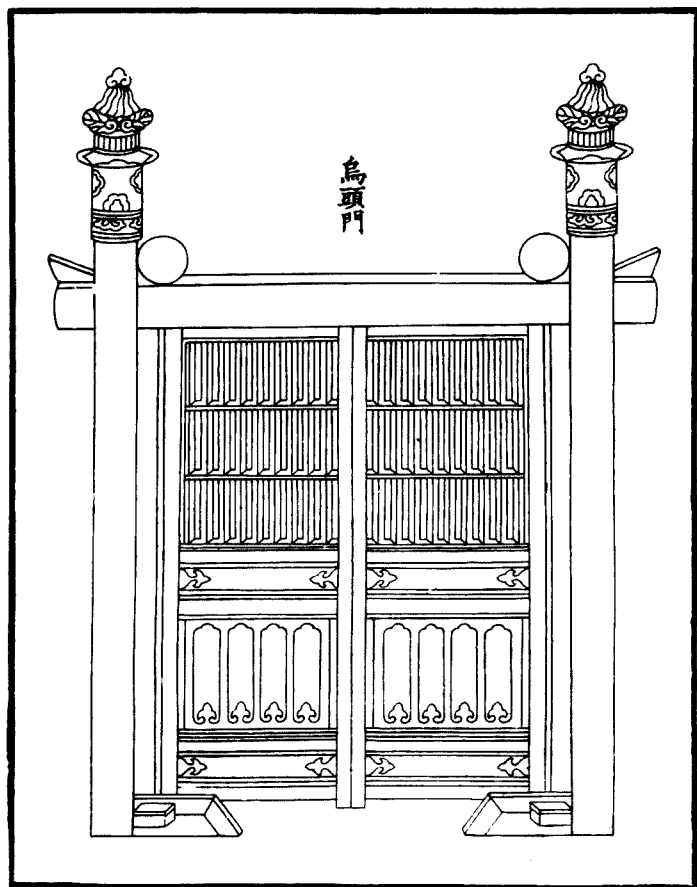

牙頭護縫軟門

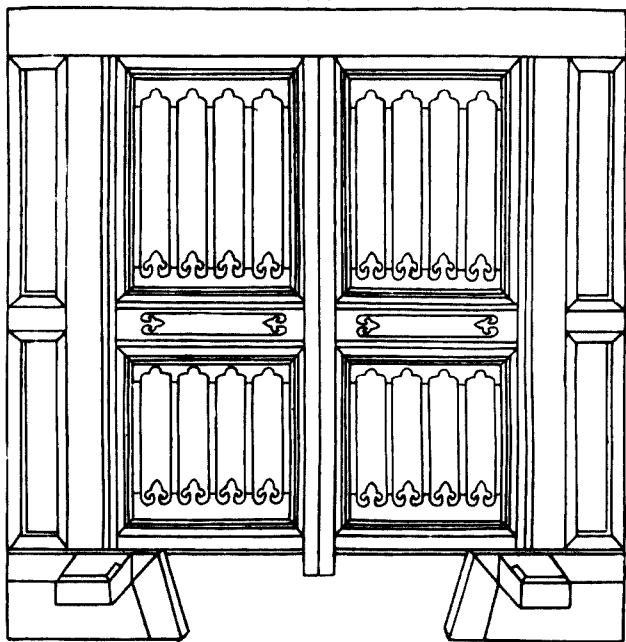

合版軟門

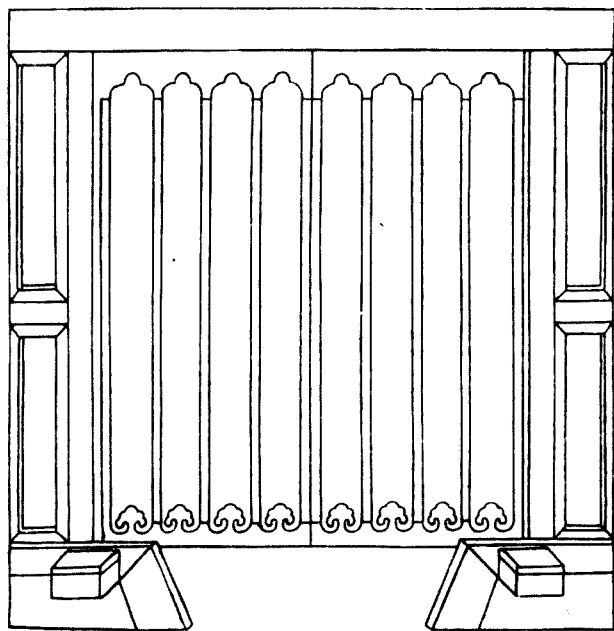

雞栖木



排叉樞

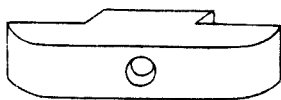

伏兔手栓

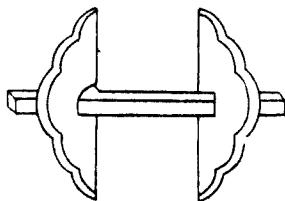

伏兔



門砧

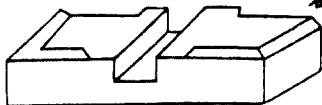

撞蝶柱



承枋樞

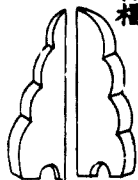

肢電窗

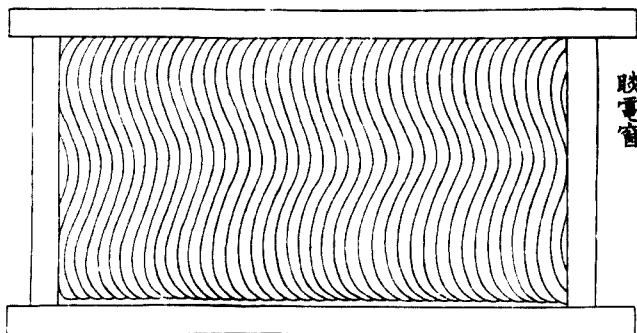

水文窗

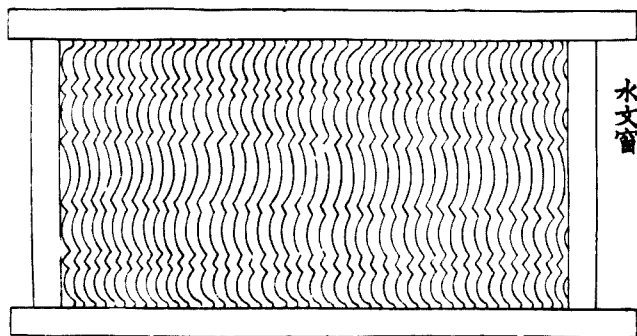

挑白毯文格眼

四程破瓣雙混平地出雙線

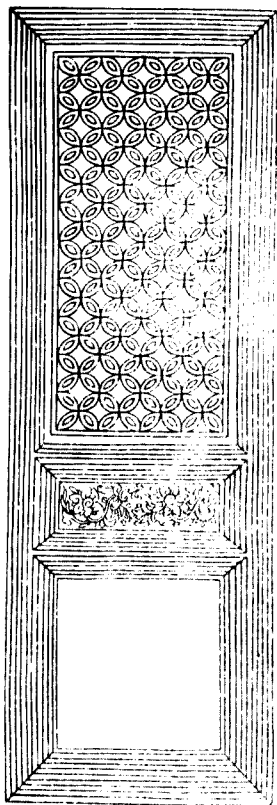

四斜毯文上出條榿重格眼

四程破瓣雙混平地出雙線

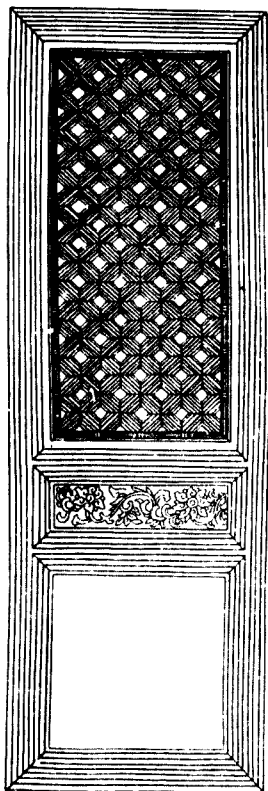

四直棊文上出條棊重格眼

四棊四混出單線

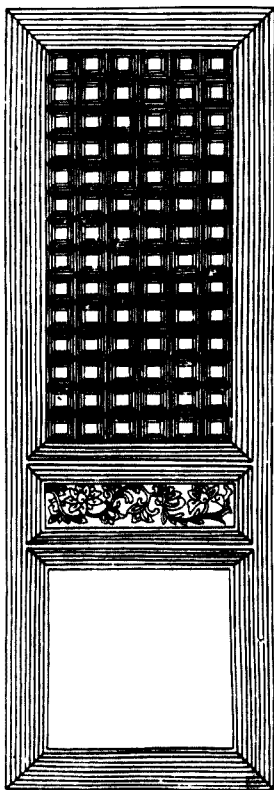

四混出雙線方格眼

四棊破瓣單混平地出單線

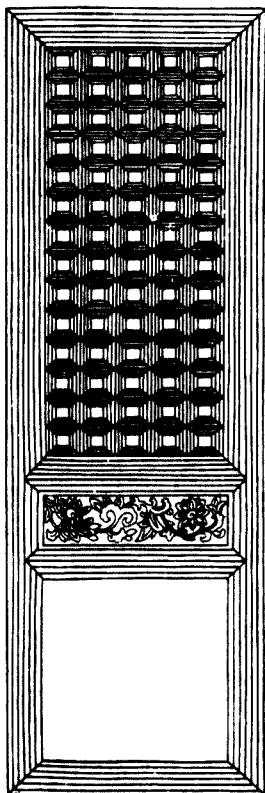

麗口絞瓣雙混方格眼

四程通混出雙線

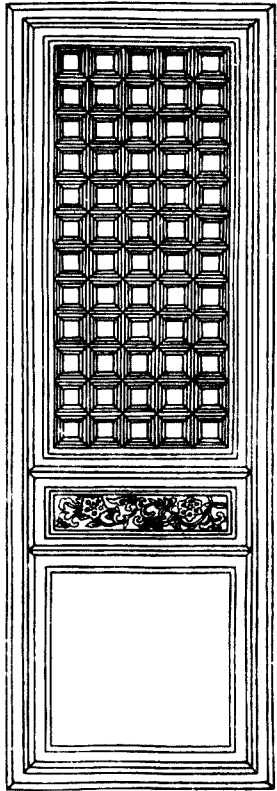

通混出雙線方格眼

四程通混壓邊線

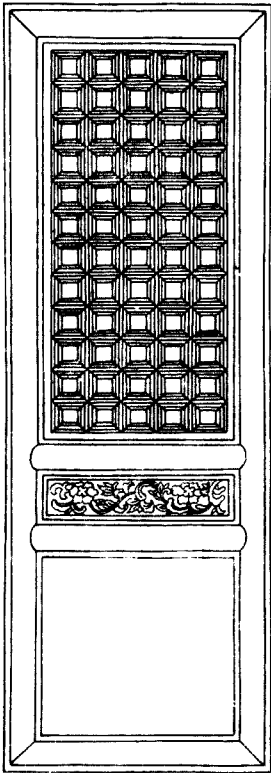

通混壓邊線四攷尖方格眼

四程素通混

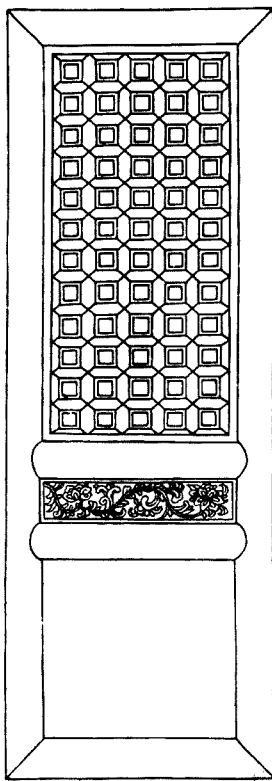

平出線方格眼

四程破瓣攷尖

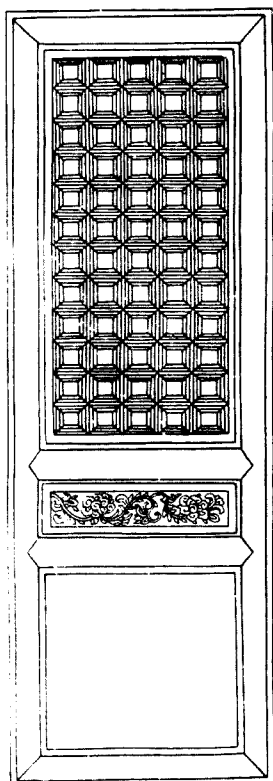

格子門額限

麗卯插栓

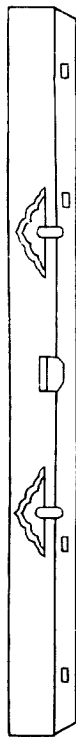

直卯撥棒

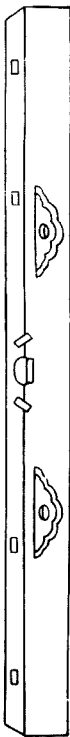

立栴



闌檻鈎窗

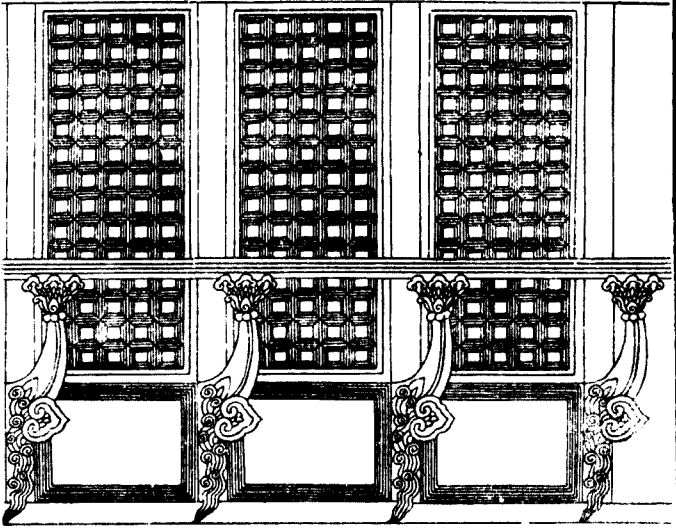

截間格子

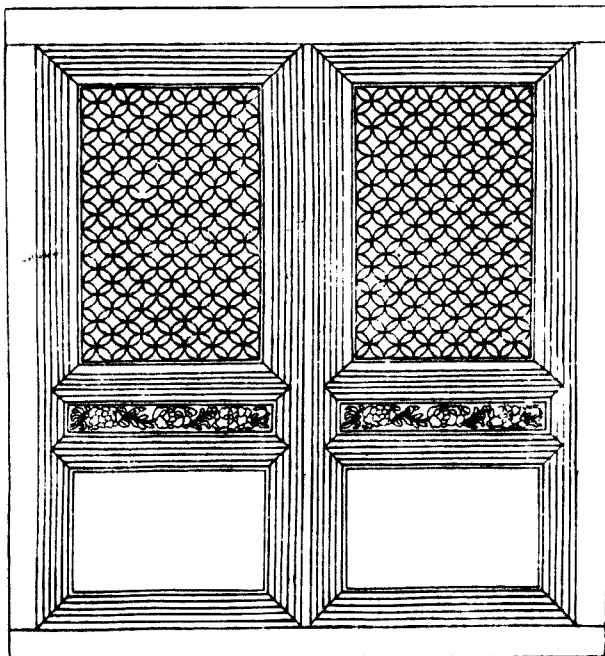

四程破瓣雙混平地出單線

四程方直破瓣

义瓣入卯

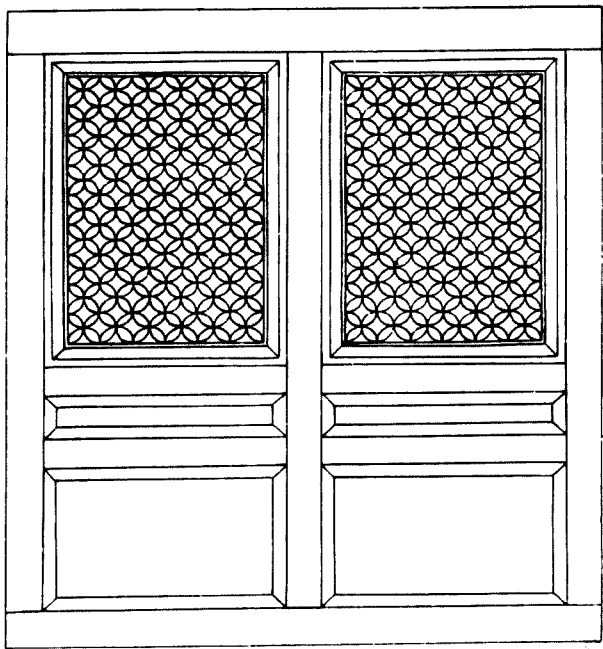

截間帶門格子

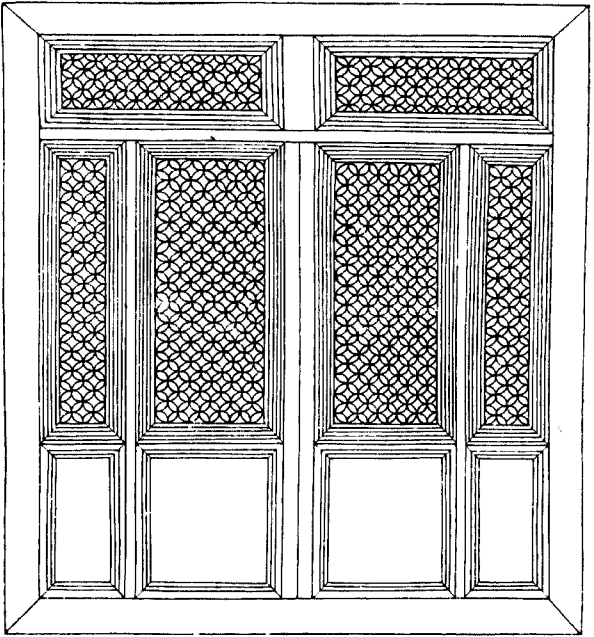

四程破瓣單混壓邊線

雕雲垂魚

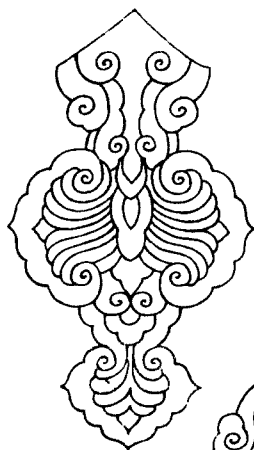

素垂魚

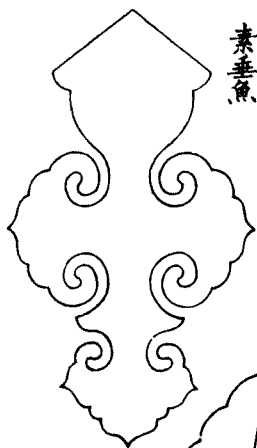

惹草



惹草



盤毬



平素餉圖等第三

營造法式

七

卷三十二

七十七

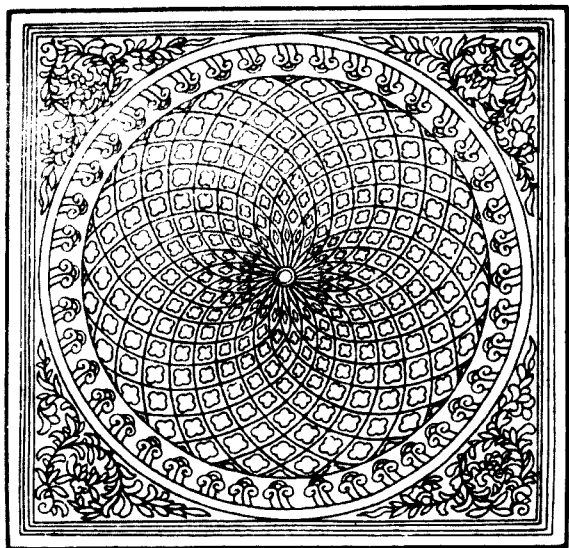

穿心關八

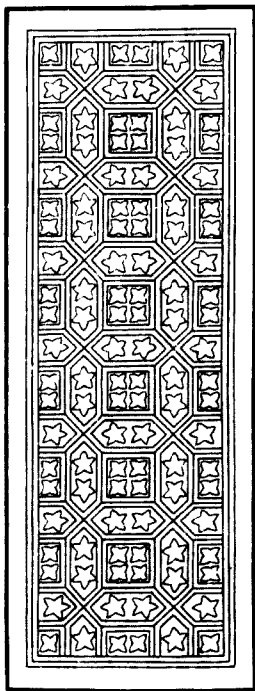

疊勝

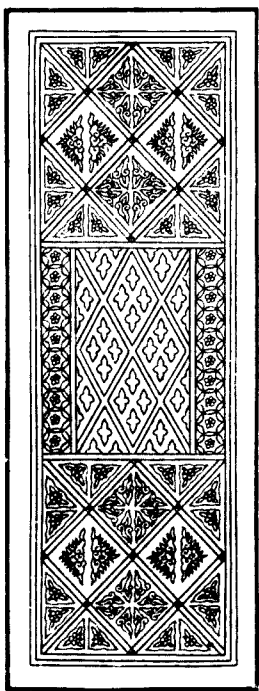

瑣子

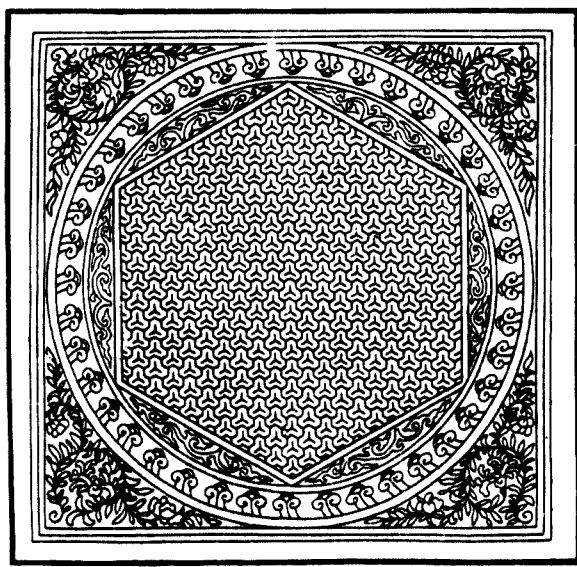

簇六毬文

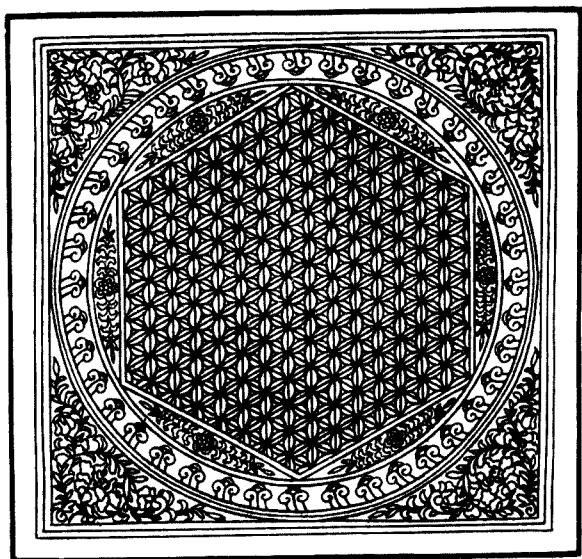

羅文

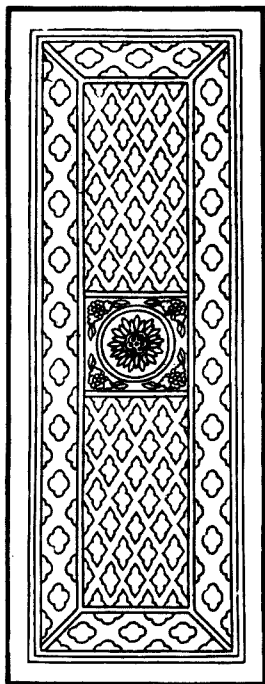

羅文壘勝

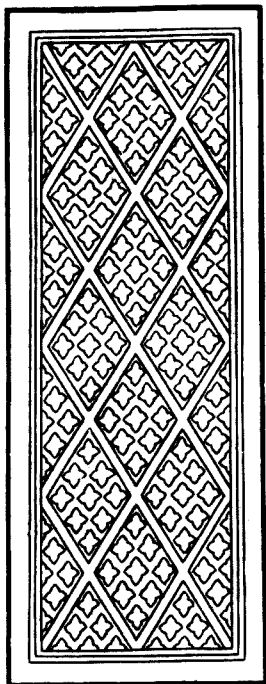

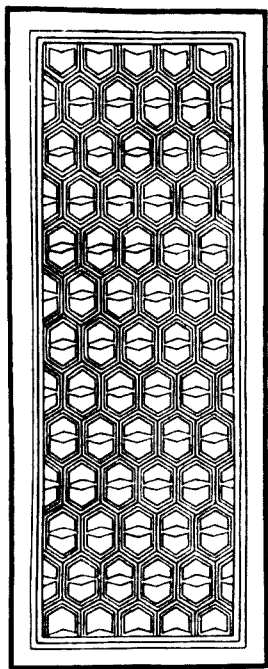

龜背

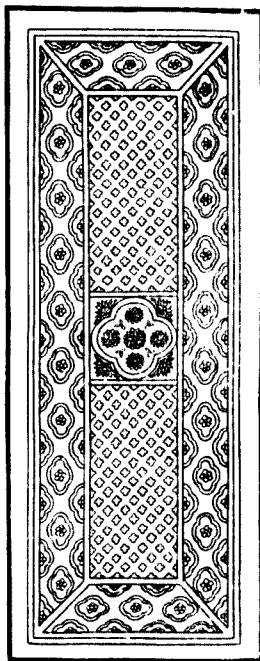

柿華

圖二十四

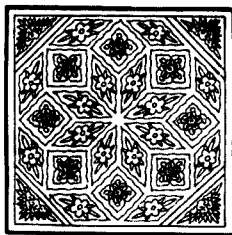
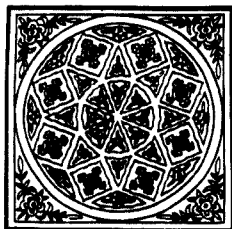
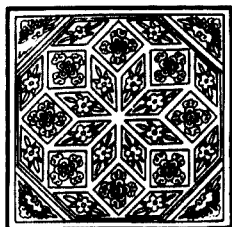

簇六填華綉文

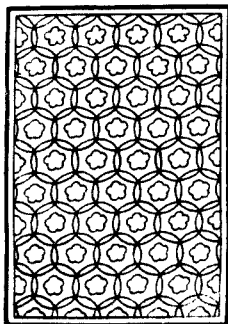

簇六重綉文

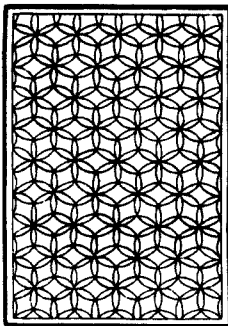

交圓華

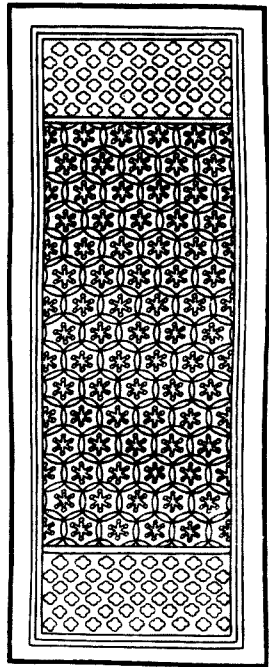

葵六雪華

平劍毳文

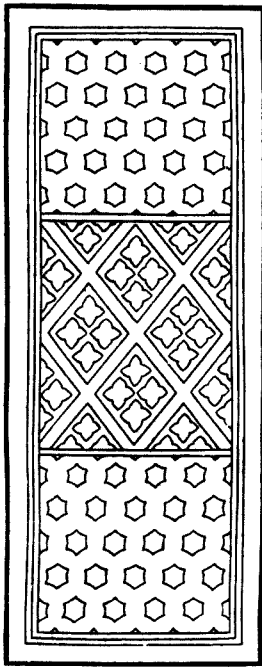

柿蒂方眼

裏槽外轉角平棊

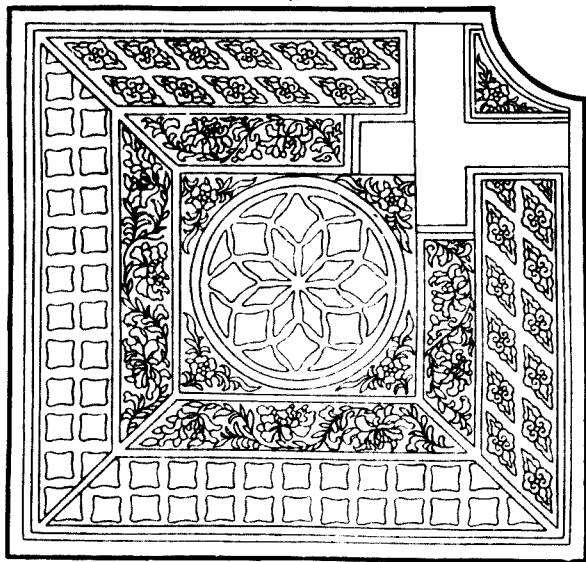

簇四稜文轉道

內方圓柿蒂相間

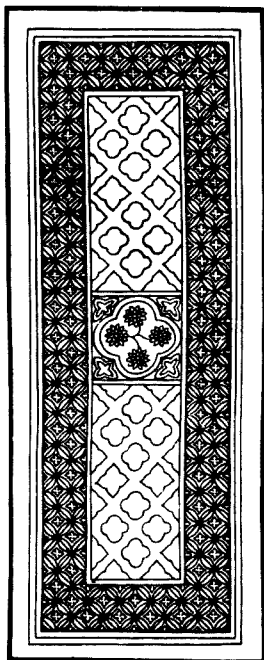

柿蒂轉道

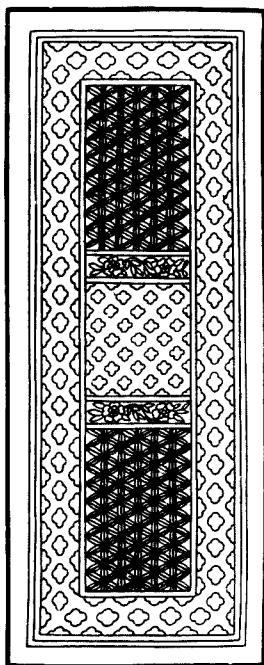

圖十八

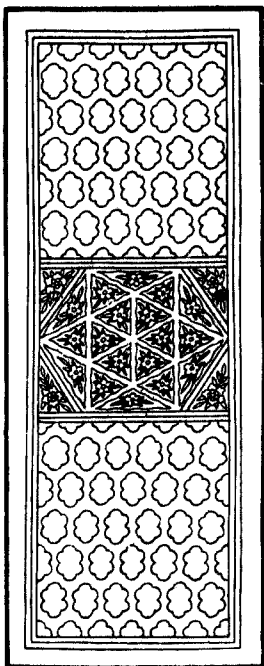

填瓣車釧毬文

圖十二

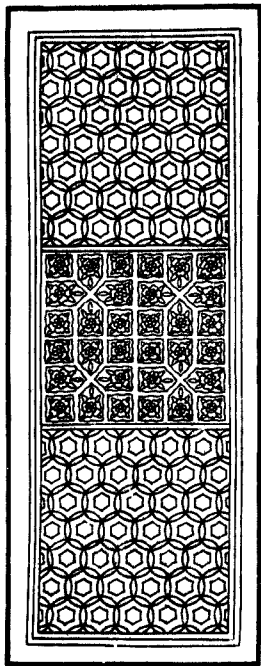

單提項鈎闌

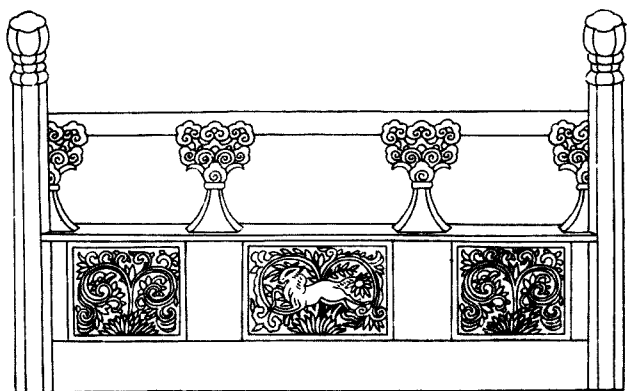

重臺壘項鈎闌

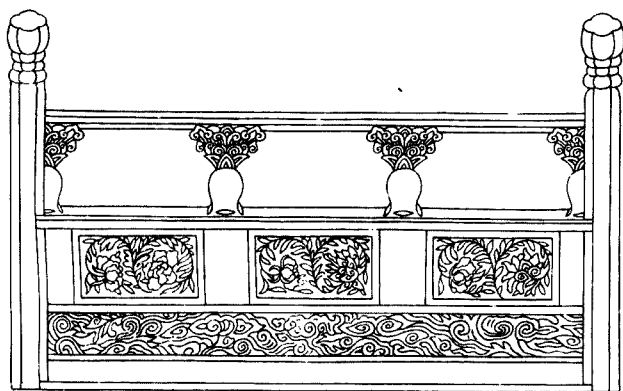

櫺子雲頭身
內一混心出
單線壓邊線

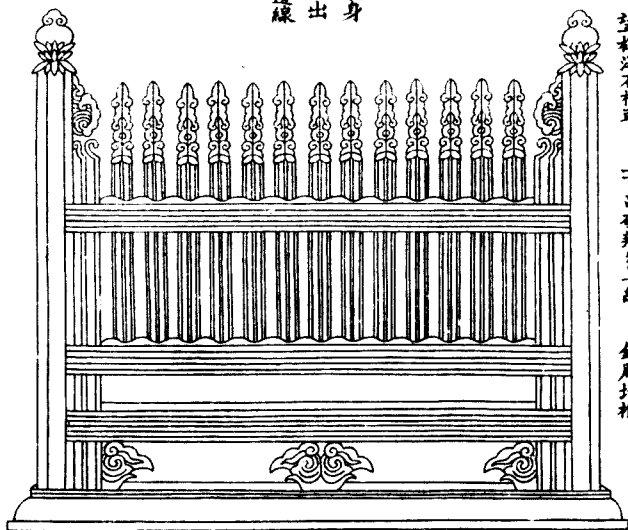

望柱海石榴頭

上下串破辨出單線

銀脚地楸

上下串破瓣壓白出單線

地霞

梳子海石榴
頭身內同上

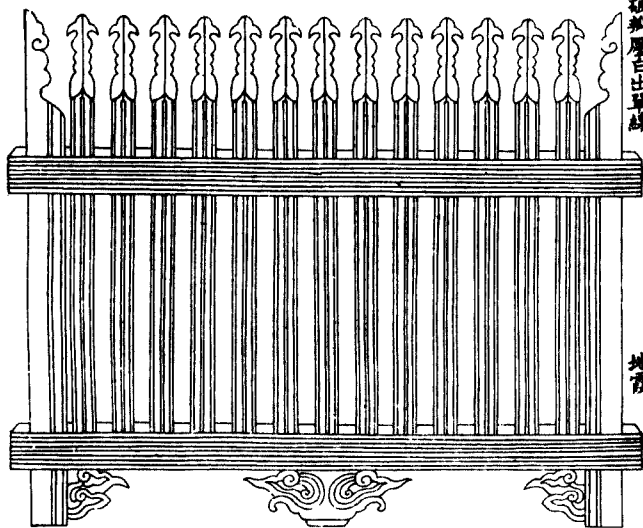

殿閣門亭等牌第三

華帶牌

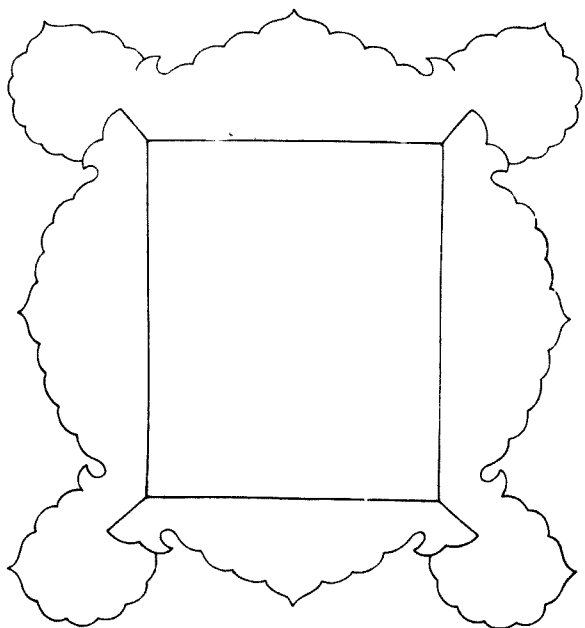

風字牌

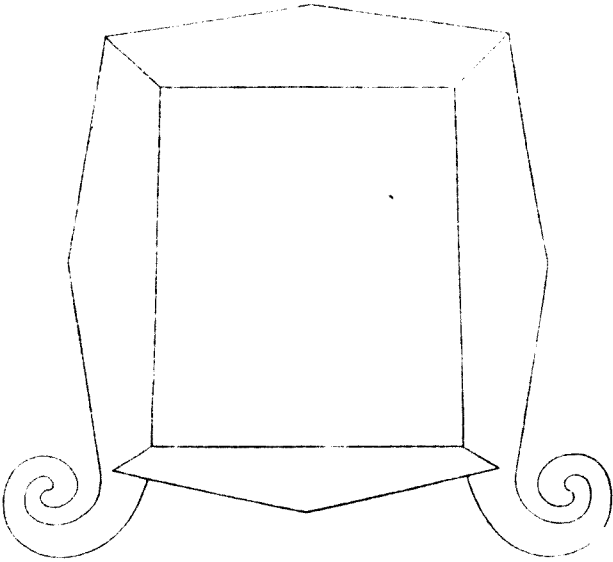

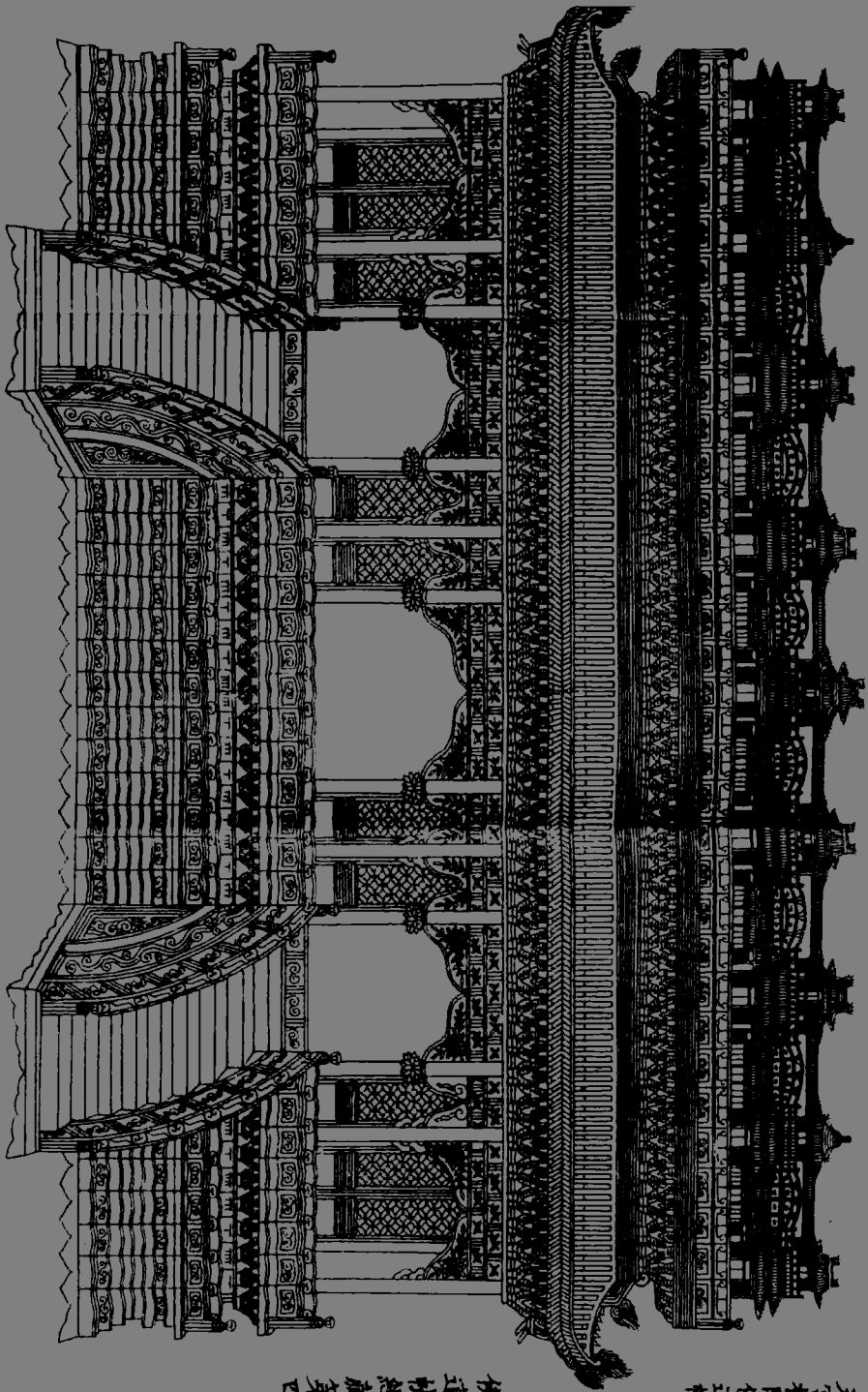

天宮樓閣佛道樓

佛道樓閣經藏第四

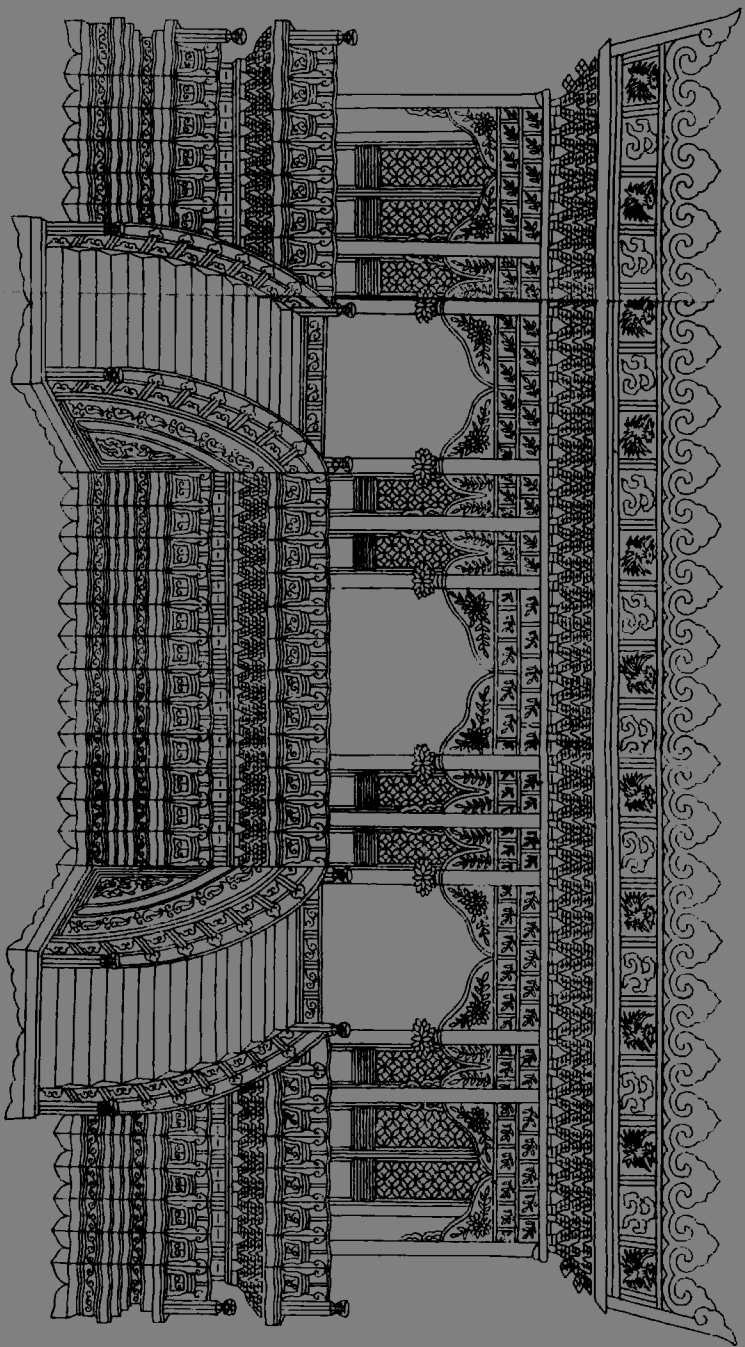

九脊牙脚小帳

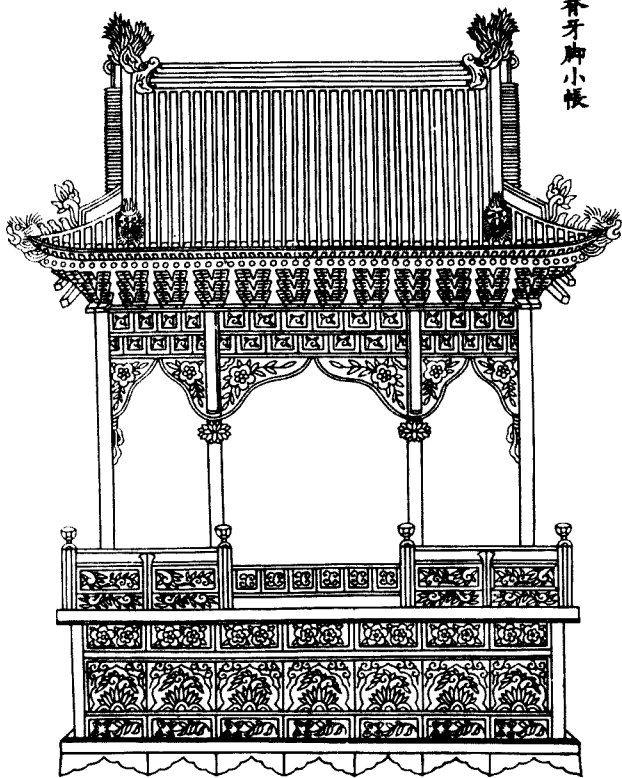

轉輪經藏

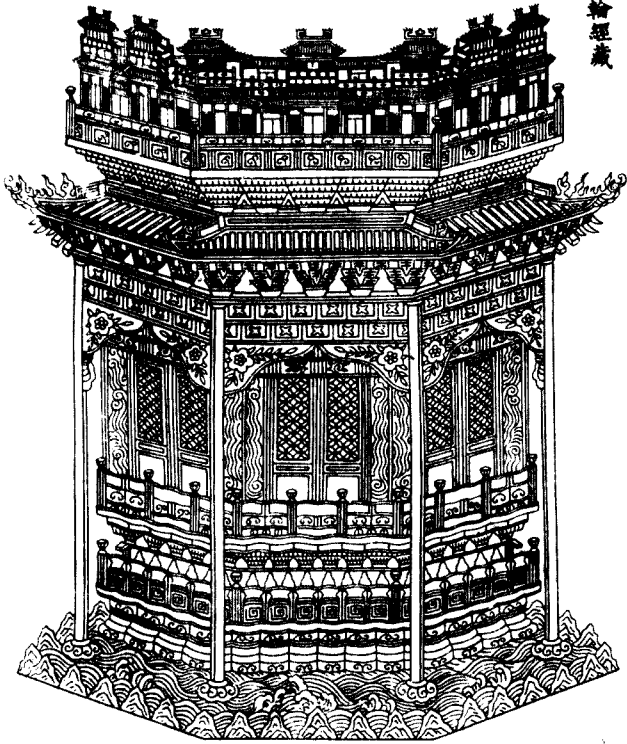

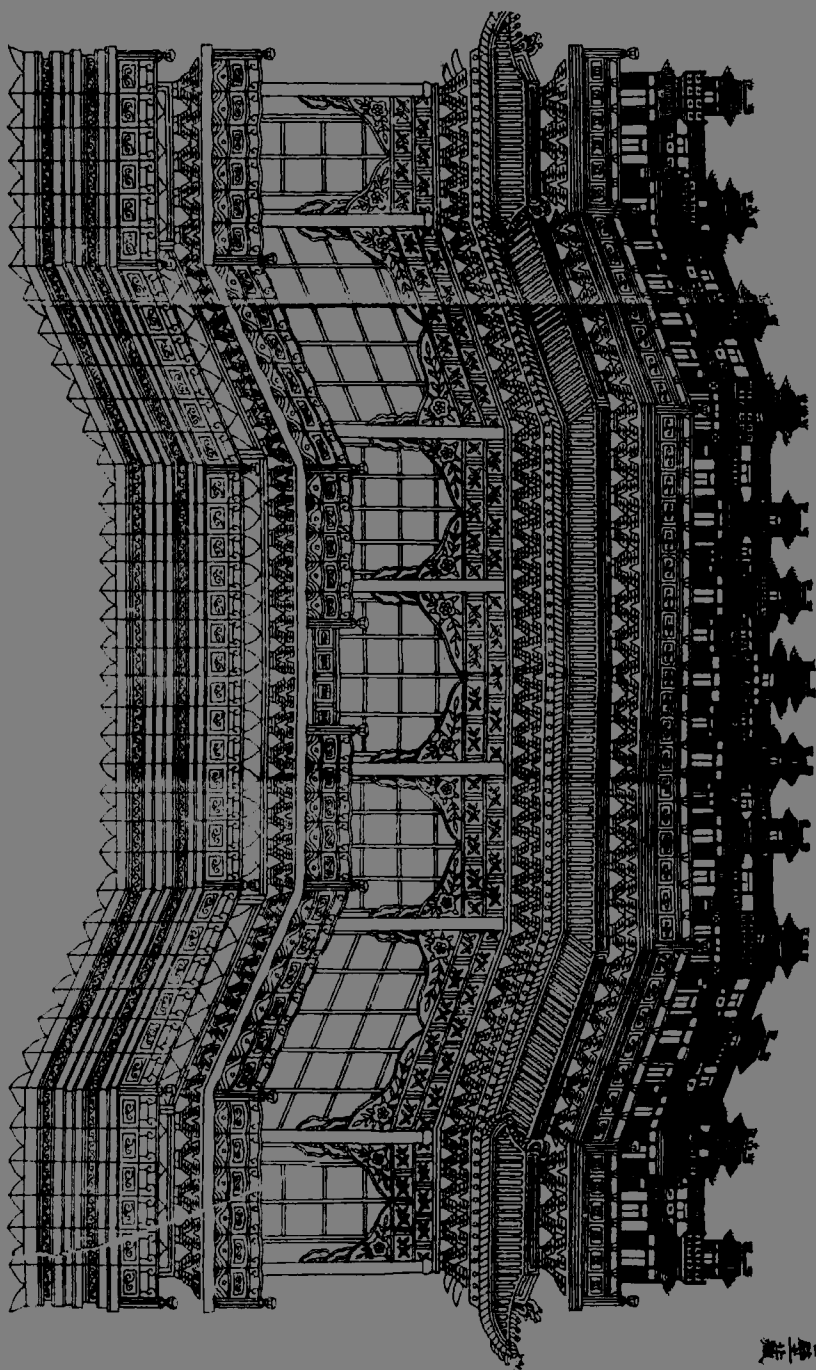

天宮學藏

彫木作制度圖樣

混作第一

玉女



化生



菩薩



拂菻



拓支



坐龍



鳳



鴛鴦



獅子



拱眼内彫插第二

重拱眼壁内花盆



牡丹

單拱眼壁内花盆



拒霜花
等雜花

格子門等腰華版第三

別地起突三卷葉



兩卷葉



一卷葉



別地蓮葉

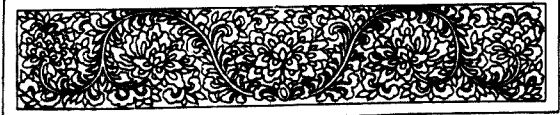

別地平卷葉



透突平卷葉



平棊華蓋第四

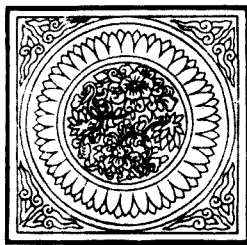

雲拱等雜樣第五

單雲頭拱



雙雲頭拱



像生華雲拱



海石榴華雲拱



重臺地霞



單地霞



像生牡丹
華地霞



像生蓮荷
華地霞



泥作纏柱龍

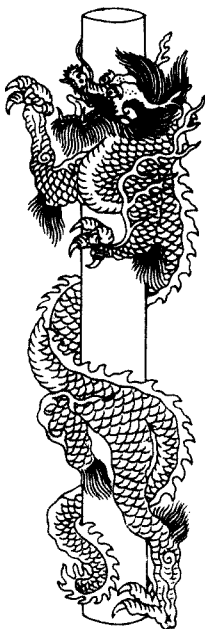

鈎蘭華版



樣頭盤子



營造法式卷第三十二

