







GL  
1  
R454  
MH

ANNALES

de la  
SOCIÉTÉ SUISSE DE ZOOLOGIE  
et du  
MUSÉUM D'HISTOIRE NATURELLE  
de la Ville de Genève

tome 106  
fascicule 3  
1999

SWISS JOURNAL OF ZOOLOGY

REVUE SUISSE DE ZOOLOGIE



GENÈVE SEPTEMBRE 1999 ISSN 0035 - 418 X

# REVUE SUISSE DE ZOOLOGIE

TOME 106 — FASCICULE 3

Publication subventionnée par:  
ACADÉMIE SUISSE DES SCIENCES NATURELLES ASSN  
VILLE DE GENÈVE  
SOCIÉTÉ SUISSE DE ZOOLOGIE

VOLKER MAHNERT  
Directeur du Muséum d'histoire naturelle de Genève

FRANÇOIS BAUD  
Conservateur au Muséum d'histoire naturelle de Genève

CHARLES LIENHARD  
Chargé de recherche au Muséum d'histoire naturelle de Genève

## Comité de lecture

Président: Ivan LÖBL — Muséum de Genève

Il est constitué en outre du président de la Société suisse de Zoologie, du directeur du Muséum de Genève et de représentants des Instituts de zoologie des universités suisses.

Les manuscrits sont soumis à des experts d'institutions suisses ou étrangères selon le sujet étudié.

La préférence sera donnée aux travaux concernant les domaines suivants: biogéographie, systématique, écologie, éthologie, morphologie et anatomie comparée, physiologie.

## Administration

MUSÉUM D'HISTOIRE NATURELLE  
1211 GENÈVE 6

Internet: <http://www.geneva-city.ch:80/musinfo/mhng/publications/revues.htm>

### PRIX DE L'ABONNEMENT:

SUISSE Fr. 225.—

UNION POSTALE Fr. 230.—  
(en francs suisses)

Les demandes d'abonnement doivent être adressées  
à la rédaction de la *Revue suisse de Zoologie*.  
Muséum d'histoire naturelle, C.P. 6434, CH-1211 Genève 6, Suisse

UCL 29 1977

# A REVISION OF THE CORYLOPHIDAE (COLEOPTERA) OF THE WEST PALAEARCTIC REGION

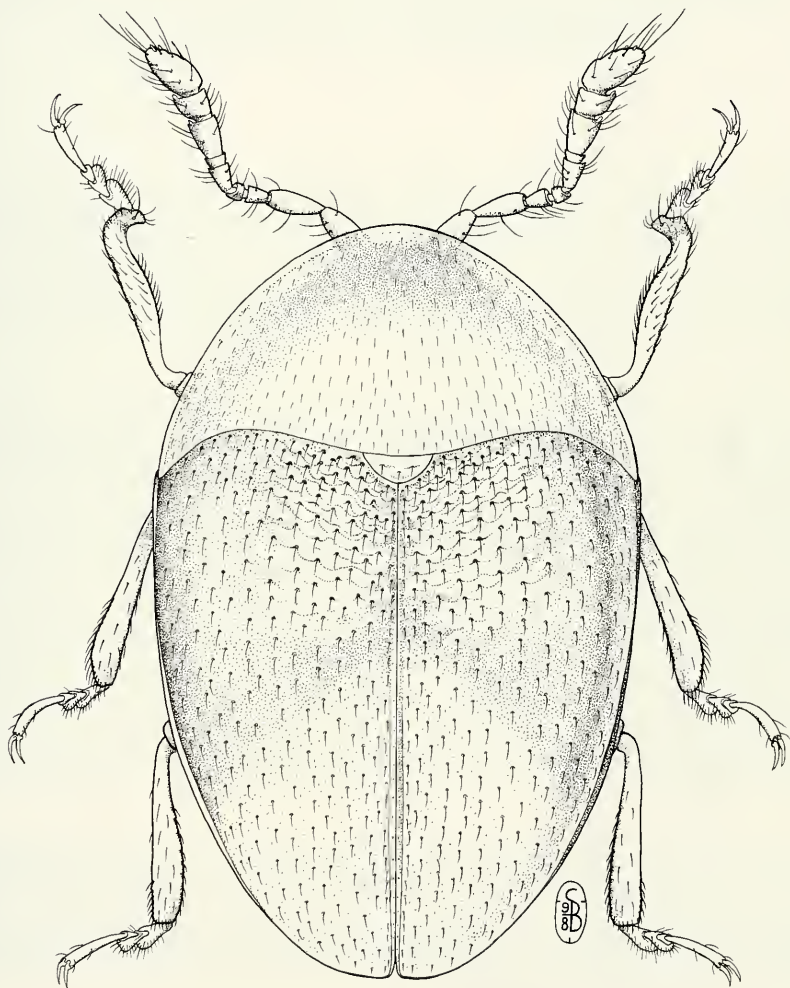

Stanley Bowstead

Stanley BOWESTEAD

## A REVISION OF THE CORYLOPHIDAE (COLEOPTERA) OF THE WEST PALAEARCTIC REGION

The Corylophidae is a family of minute beetles placed in the Cerylonid group of the Cucujoidea. As many allied, they are thought to be mould feeders, being attracted to fine mould that occurs on vegetation as it decays. They are world wide in distribution. The present taxonomic treatment of the Palaeartic taxa is particularly inadequate. Lack of reliable keys makes uncertain even identification of common European species.

For this revision all available type material and numerous collections totalizing more than 13'000 specimens were examined. The morphological characters are re-appraised. The structures of the head, antennae, prothorax, metathorax, and prolegs relevant for genera, and the habitus, microsculpture, penis with the internal sac, and spermatheca relevant for species are shown on 426 illustrations. The spermathecal characters are used for the first time in the family and they proved to be diagnostic. A cladistic analysis is performed to hypothesize the phylogenetic relationships. All taxa are redefined. Presently, four subfamilies are distinguished: Peltinodinae, Corylophinae, Orthoperinae and Rypobiinae, and 45 species are recognized in the area studied. Latter stretches from the islands of Azores in the west, to the Ural mountains in the east and extends southwards to include Afghanistan and all of North Africa north of Sahara.

Five new species and one new tribe are described. Lectotypes are designated for ancient type material. New synonymies of genera and species are indicated, and full synonymy is given for all Palaeartic species. Keys to subfamilies, tribes, genera and species are provided. Distribution, records and habitat types of species are given.

This publication is addressed to systematicians, ecologists, entomologists interested in faunistic research of the individual European countries as well as to scientific libraries.



***Instrumenta Biodiversitatis* n° 3**

**Ed. Muséum d'histoire naturelle, Ville de Genève, July 1999,  
202 pp., 424 figures**

**ISBN 2-88139-006-5**

**Price: 60 Swiss francs + handling and postage**

Orders should be mailed to: Muséum d'histoire naturelle, c/o Mme  
Nathalie Chollet, Case postale 6434, CH-1211 Genève 6, Switzerland.  
Fax: +41 22 418 63 01, or to e-mail: volker.mahnert@mhn.ville-ge.ch

We are ordering ..... copy(ies) of "A Revision of the Corylophidae  
(Coleoptera) of the West Palaearctic Region".

Name .....

Mailing address .....

Address of invoice (if different) .....

Fax number or e-mail..... Signature .....



ANNALES

de la  
SOCIÉTÉ SUISSE DE ZOOLOGIE  
et du  
MUSÉUM D'HISTOIRE NATURELLE  
de la Ville de Genève

tome 106  
fascicule 3  
1999

SWISS JOURNAL OF ZOOLOGY

REVUE SUISSE DE ZOOLOGIE



GENÈVE SEPTEMBRE 1999 ISSN 0035 - 418 X

# REVUE SUISSE DE ZOOLOGIE

TOME 106 — FASCICULE 3

Publication subventionnée par:  
ACADÉMIE SUISSE DES SCIENCES NATURELLES ASSN  
VILLE DE GENÈVE  
SOCIÉTÉ SUISSE DE ZOOLOGIE

VOLKER MAHNERT  
Directeur du Muséum d'histoire naturelle de Genève

FRANÇOIS BAUD  
Conservateur au Muséum d'histoire naturelle de Genève

CHARLES LIENHARD  
Chargé de recherche au Muséum d'histoire naturelle de Genève

## *Comité de lecture*

Président: Ivan LÖBL — Muséum de Genève

Il est constitué en outre du président de la Société suisse de Zoologie, du directeur du Muséum de Genève et de représentants des Instituts de zoologie des universités suisses.

Les manuscrits sont soumis à des experts d'institutions suisses ou étrangères selon le sujet étudié.

La préférence sera donnée aux travaux concernant les domaines suivants: biogéographie, systématique, écologie, éthologie, morphologie et anatomie comparée, physiologie.

## *Administration*

MUSÉUM D'HISTOIRE NATURELLE  
1211 GENÈVE 6

Internet: <http://www.geneva-city.ch:80/musinfo/mhng/publications/revues.htm>

### PRIX DE L'ABONNEMENT:

SUISSE Fr. 225.—

UNION POSTALE Fr. 230.—  
(en francs suisses)

Les demandes d'abonnement doivent être adressées  
à la rédaction de la *Revue suisse de Zoologie*,  
Muséum d'histoire naturelle. C.P. 6434, CH-1211 Genève 6, Suisse

**A revision of the *Scopaeus sulcicollis* species group, with description of a new species from North-East Anatolia (Coleoptera, Staphylinidae, Paederinae)**

Johannes FRISCH

Institut für Allgemeine und Spezielle Zoologie, Justus-Liebig-Universität Gießen, Stephanstr. 24, D-35390 Gießen, FRG.

**A revision of the *Scopaeus sulcicollis* species group, with description of a new species from North-East Anatolia (Coleoptera, Staphylinidae, Paederinae).** - The West Palaearctic *Scopaeus sulcicollis* species group is defined by external morphological and genital features. It comprises *S. ampliatus* Binaghi (North-East Italy, Corsica, Sardinia), *S. argonauta* Gusarov (Caucasus), *S. ponticus* sp. n. (North-East Anatolia), *S. rubidus* Mulsant & Rey (South-West Europe) and *S. sulcicollis* Stephens (West-, Central-, South Europe), which are illustrated and, except *S. argonauta* and *S. sulcicollis*, described using external morphological, genital and meristic characters. A lectotype is designated for *S. rubidus*.

**Key-words:** Staphylinidae - Paederinae - *Scopaeus sulcicollis* group - West Palaearctic Region - taxonomy.

INTRODUCTION

Within *Scopaeus* (Staphylinidae, Paederinae), both earlier and more recent authors (e. g. BINAGHI 1935; COIFFAIT 1960, 1968, 1984; FAUVEL 1872; HORION 1965; LOHSE 1964; MULSANT & REY 1854, 1855; REITTER 1909) have frequently employed subgenera which, however, are poorly founded and do not represent monophyletic groups (FRISCH 1996). It was suggested in subsequent revisionary publications on West Palaearctic *Scopaeus* (e. g. FRISCH 1997, 1998) that these subgenera be replaced by informal groups of related species. *Scopaeus sulcicollis* Stephens and *S. argonauta* Gusarov were referred to the *S. sulcicollis* group (FRISCH 1997) but the complete group has not been revised until now.

BINAGHI (1935) noted the close relationship of *Scopaeus ampliatus* Binaghi, *S. rubidus* Mulsant & Rey and *S. sulcicollis* Stephens, 1832 (= *S. cognatus* Mulsant & Rey sensu BINAGHI 1935), but used inappropriate characters (parameres lacking, apical lobes being fused or nearly fused at apex) to define the species group. A lack of parameres (lateral lobes sensu FRISCH 1994) is a character of several groups of related species, and the apical lobes of the relevant species are, in fact, absolutely separate. Recently, GUSAROV (1992) described *S. argonauta* from the Caucasus and compared it

with *S. sulcicollis*. When designating a lectotype for the latter, FRISCH (1997) referred both species to the *S. sulcicollis* group, referring to aedeagal characters as the shape of the apical lobes and the apically undivided, ventrally bent dorsal lobe, and to the abdominal sternite 8 having distinct, apico-lateral impressions, which are divided by an elevated middle field.

According to the present concept, the *Scopaeus sulcicollis* group comprises five species in the West Palaearctic realm: *S. ampliatus* (North-West Italy, Corsica, Sardinia), *S. argonauta* (Caucasus), *S. ponticus* sp. n. (North-East Anatolia), *S. rubidus* (South-West Europe) and *S. sulcicollis* (West-, Central-, South Europe). These species agree in the discernibly enlarged tempora, in the more or less dilated mesotibiae, in the laterotergites 9 lacking a distinct dorsal tooth, in the aedeagus lacking lateral lobes and in the inner ventral margins of the apical lobes each bearing a row of fine setae. As the first features occur in several groups of related species, only the inner rows of setae of the apical lobes may be an apomorphic feature of the *S. sulcicollis* group. The species, except *S. ampliatus*, share furthermore two longitudinal, lateral impressions on abdominal sternite 8 divided by an elevated middle field. As these characters of abdominal sternite 8 occur in several species groups but lack in *S. ampliatus*, they are not usable to define the *S. sulcicollis* group. Additionally, the aedeagi of *S. ampliatus*, *S. rubidus* and *S. ponticus* sp. n. share somewhat asymmetrical dorsal lobes and apical lobes.

The present review gives a more accurate definition of the *S. sulcicollis* group. It presents redescriptions and the distribution patterns of *S. ampliatus* Binaghi and *S. rubidus* Mulsant & Rey and additional notes on *S. argonauta*, along with illustrations of all species included. *Scopaeus argonauta* and *S. sulcicollis* were redescribed in FRISCH (1997). Finally, *Scopaeus ponticus* sp. n. from North-East Anatolia is included in the *S. sulcicollis* group.

## MATERIAL AND METHODS

The terminology of the aedeagal features is used as in FRISCH (1994). The spermatheca and the genital sclerites are named as in FRISCH (1996) and UHLIG (1989). Abdominal sclerites are counted from the first morphological segment.

Specimens were measured using a binocular microscope with an eye-piece linear micrometer. Measurements and ratios are based on ten specimens of both sexes, which are including maximum variation range in size and form, and are defined as follows: total length = interval from the apical margin of the mandibles to the end of the abdomen; forebody length = interval from the apical margin of the mandibles to the posterior margin of the elytra at suture; length of head = interval from the apical margin of the clypeus to the posterior margin; HLW = head length : head width; PLW = pronotal length : pronotal width; HPW = width of head : pronotal width; HPL = length of head : pronotal length; PSL = pronotal length : elytral sutural length (excluding scutellum); PLL = pronotal length : elytral lateral length; ELW = elytral lateral length : elytral width; ET = eye length : temporal length (both measured laterally); MT = mesotibial length : mesotibial width; A = length (measured without the basal and distal

tapering): width of the antennal segments 1-11; T = length : width of the central area (between sclerite margins) of the tergite 10; V = length : width of the central area of the female valve.

Detailed data are given only for the type specimens. The synonymy of the species presents only primary references. The study material is deposited in the following institutions and private collections: BMNH = The Natural History Museum, London; DEIC = Deutsches Entomologisches Institut, Eberswalde; FCNB = Frey Collection, Naturhistorisches Museum, Basel; HHNM = Hungarian Natural History Museum, Budapest; ISNB = Institut Royal des Sciences Naturelles de Belgique, Brussels; JFCG = J. Frisch Private Collection, Gießen; MCSN = Museo Civico di Storia Naturale "Giacomo Doria", Genova; MHNG = Muséum d'histoire naturelle, Genève; MHNL = Musée Guimet d'histoire naturelle, Lyon; MNHN = Muséum National d'Histoire Naturelle, Paris; NHMW = Naturhistorisches Museum, Wien; SMTD = Staatliches Museum für Tierkunde, Dresden; TLMF = Tiroler Landesmuseum Ferdinandeum, Innsbruck; VACH = V. Assing Private Collection, Hannover; VGCP = V. Gusakov Private Collection, St. Petersburg; ZMAL = Zoological Museum, Academy of Sciences, St. Petersburg; ZMHB = Museum für Naturkunde, Berlin.

## TAXONOMY

### **Scopaeus argonauta** Gusarov

Figs 4-6, 17, 22, 25, 29, 34

*Scopaeus* (s. str.) *argonauta* Gusarov, 1992: 781. Holotype ♂, Georgia, Adzharia, Kintrishkiy Nature Reserve, 500 m, 30.07.1990, Gusarov (ZMAL); examined.

*Scopaeus argonauta*; FRISCH 1997: 537.

*Material examined.* Georgia: holotype ♂, Adzarskaja, Kintrishkiy Nature Reserve, 500 m, 30.07.1990, Gusarov (ZMAL); paratypes 1 ♂, 1 ♀, same data as holotype (VGCP, ZMAL); paratype ♀, Adzarskaja, Pirveli Maisi, Agdra, 05.08.1990, Gusarov (VGCP); paratypes 2 ♀, Abchazskaja, Ganakhleba, 26.07.1990, Gusarov (VGCP); paratype ♀, Abchazskaja, Gumistinskiy Nature Reserve, Tsumuri, Ashamgvara ridge, 900 - 1100 m, 03.07.1981, Gusarov (VGCP); paratype ♂, Abchazskaja, Gumistinskiy Nature Reserve, Tsumuri, 420 m, 20.07.1990, Gusarov (VGCP). Russia: paratype ♂, Krasnodar Kraj, Lasarewskaja, Aul Kirowa, 29.09.1986, Kirejtshuk (ZMAL).

*Comments.* The similar shape of the aedeagus and the abdominal sternite 8 of males suggests that *Scopaeus argonauta* (figs 4-6, 17) and *S. sulcicollis* (figs 1-3, 16) are closely related (FRISCH 1997, GUSAROV 1992). Meanwhile, the holotype ♂ and paratypes (3 ♂, 5 ♀), which were not traceable then, have been examined, and *S. argonauta* turned out to be a species of quite variable elytral length and not distinguished constantly from *S. sulcicollis* by the longer elytra. Specimens of *S. argonauta* with shorter elytra laterally exceeding the pronotal length by just about a seventh (PLL 0,86) cannot be distinguished from *S. sulcicollis*. *Scopaeus argonauta* is characterized furthermore by a rather variable shape of the head, which has the tempora rather parallel or notably widened.

### **Scopaeus ponticus** sp. n.

Figs 7-9, 18, 23, 26, 30, 35

*Material examined.* Holotype ♂, Turkey: Trabzon, Arakli, 100 m, 24.05.1997, collected on the narrow bank of a small stream with damp, fine gravel and sand, Frisch (MHNG). Paratypes. 7 ♀, same data as holotype (JFCG, MHNG).

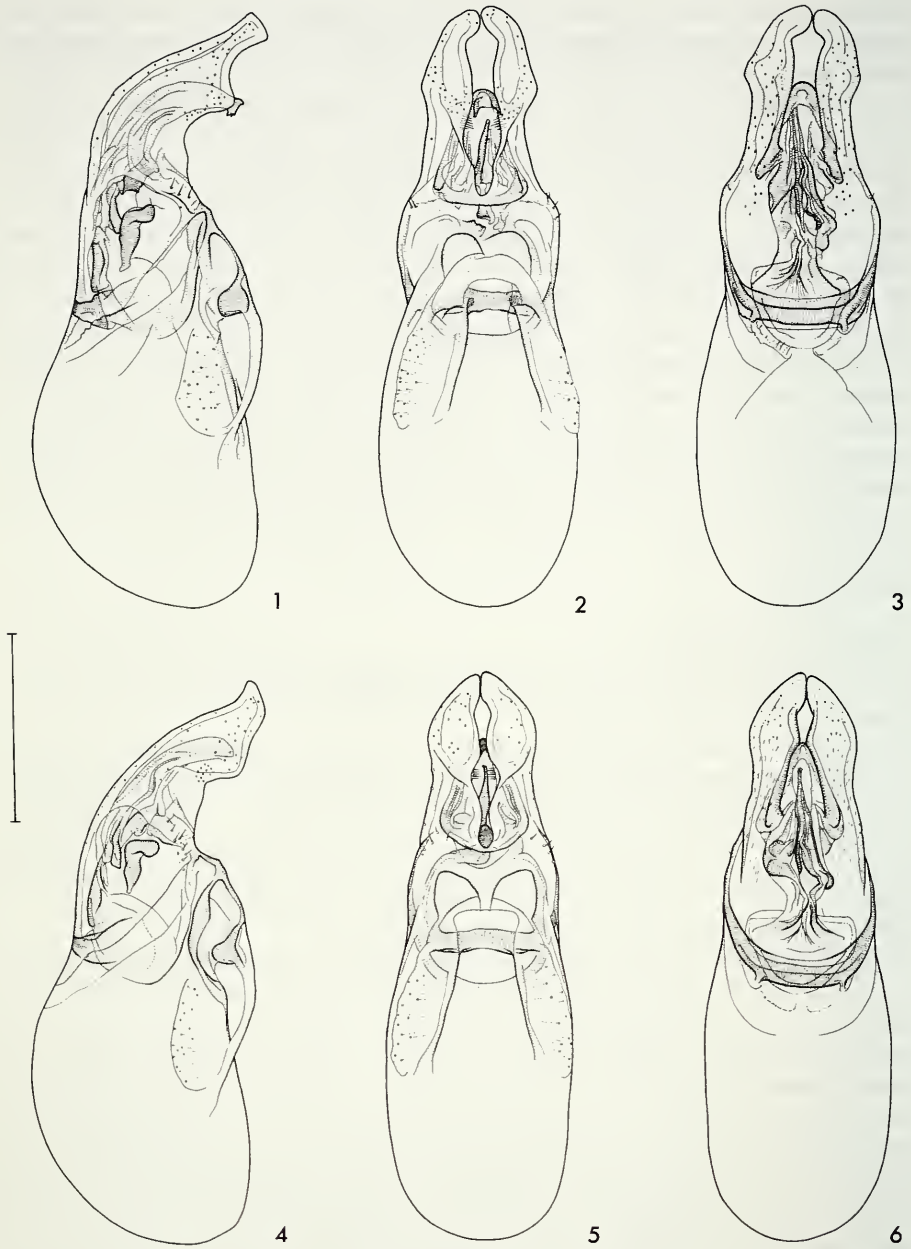

FIGS 1-6

*Scopaeus argonauta*, ♂. Caucasus: aedeagus in 1) lateral, 2) ventral, 3) dorsal view. *Scopaeus sulcicollis*, ♂ lectotype: aedeagus in 4) lateral, 5) ventral, 6) dorsal view. Scale bar = 0.1 mm.



*Description.* Length 3.2-3.9 mm; forebody 1.6-1.8 mm. Dark coloured species. Forebody brown, pronotum slightly lighter brown, elytra blackish without distinct sutural or distal lightenings. Abdomen black, segments 8-10 dark brown. Appendages unicolorously light brown. Punctuation distinct, relatively coarse on elytra, but rather fine on pronotum, reticulation rather obsolete, forebody therefore somewhat shining. Head trapezoid with notably widened tempora, distinct hind angles and with a rather concave posterior margin, about a tenth longer than wide and up to almost a fifth wider than pronotum. Eyes rather small, distinctly less than half as long as tempora. Flightless species. Elytra rather short and slender, laterally as long as pronotum or exceeding pronotal length just by about a tenth, at suture up to a fifth shorter than pronotum. Membranous wings strongly reduced, not exceeding double the length of the elytra. Protarsomeres 1-4 in both sexes twice as wide as long. Mesotibia moderately dilated, about five times as long as wide. Antennae rather slender, distal antennomeres almost quadrate. Laterotergite 9 (fig. 23) without a distinct dorsal tooth but slightly dilated apico-dorsally. Male sternite 8 (fig. 18) with a triangular emargination in the apical third and two medio-lateral, lighter coloured, narrow, longitudinal impressions which bear no setae and are divided by a broad, elevated middle field with lateral margins distinct from the lateral impressions. Aedeagus (figs 7-9) with slightly asymmetrical apical lobes and dorsal lobe, with apices somewhat bent to the right in dorsal view. Apical lobes about half as long as phallobase and broadangled bent ventrally in the distal half, their ventral margins in the distal half each extended into a longer, acute distal and a shorter, rounded proximal lobe, which are divided by a semicircular emargination. Proximal lobes bent laterally in ventral view. Outer margins of the apical lobes in dorsal view evenly narrowed in the basal half but somewhat rounded and dilated in the distal half, their inner margins in ventral view each bearing a row of about six short setae. Dorsal lobe conspicuously long and slender, broadangled bent ventrally in the distal half just as the apical lobes, its acute apex strongly projects from the apex of the apical lobes and is extended ventrally to a strong, median tooth. Lateral lobes reduced to lateral groups of few, short setae. Spermatheca (fig. 35) with members slightly bent in lateral view. Chamber strongly triangular, process rather slender.

*Ratios.* HLW 1.06-1.13; PLW 1.15-1.23; HPW 1.1-1.17; HPL 1.0-1.06; PSL 1.07-1.21; PLL 0.87-0.99; ELW 1.16-1.23; ET 0.39-0.48; MT 4.9-5.6; A 2.2, 1.3, 1.3, 1.1, 1.1, 1.1, 1.0, 1.0, 1.0, 0.9, 1.7; T 1.9; V (♀) 4.4.

*Comments.* Externally, *S. ponticus* sp. n. is difficult to distinguish from *S. sulcicollis* and *S. argonauta*, but may be separated from *S. argonauta* by the reduced metathoracic wings. Additionally, *S. ponticus* differs from the specimens examined of *S. argonauta*, which have elytra exceeding the pronotal length by about a fifth, by their discernibly shorter elytra (see FRISCH 1997). However, bearing in mind the meagre material examined, the length of the membranous wings may be variable in *S. ponticus*, and the length of the elytra may be as variable as in *S. sulcicollis* and *S. argonauta*. Judging from the aedeagal characters, *S. ponticus* sp. n. is isolated within the *S. sulcicollis* group.

**Scopaeus rubidus** Mulsant & Rey

Figs 10-12, 19, 24, 27, 31, 36

*Scopaeus rubidus* Mulsant & Rey, 1854: 171; 1855: 59. Lectotype ♂, France, Provence (MHNL); here designated (examined).

*Scopaeus (Polyodontus) rubidus*; FAUVEL 1872: 313.

*Scopaeus (Heteroscopaeus) rubidus*; COIFFAIT 1960: 285.

*Scopaeus (Anomoscopaeus) rubidus*; COIFFAIT 1968: 426.

*Scopaeus subcylindricus* Scriba, 1868: 156; synonymized with *S. rubidus* by FAUVEL 1871: 136.

*Material examined* (291 specimens). Danmark (MNHN). France: Lectotype ♂ and paralectotype 1♀ of *S. rubidus*, Provence (MHNL); paralectotypes 1♂, 3♀ of *S. rubidus*, Lyon (MHNL); Ain (NHMW); Allier (MNHN); Alpes de Haute-Provence (MNHN); Alpes Maritimes (MHNG, MNHN); Aube (ISNB); Aude (FCNB, NHMW, MNHN, SMTD); Bas-Rhin (MNHN); Bouches-du-Rhône (NHMW); Drôme (ISNB); Gironde (MNHN); Haute-Garonne (ISNB, MNHN); Hautes-Pyrénées (ISNB); Hérault (ISNB, NHMW, MNHN); Isère (MHNG, MNHN); Landes (MNHN); Loiret (NHMW, MNHN); Pyrénées-Atlantiques (ISNB); Rhône (DEIC, NHMW, MNHN); Savoie (ISNB); Var (ISNB, MNHN); Vaucluse (HNHM, MHNG, MNHN). Italy: Abruzzi (NHMW); Emilia-Romagna (JFCG, NHMW, TLMF); Lazio (DEIC, MHNG, NHMW, ZMHB); Liguria (NHMW); Piemonte (BMNH, DEIC, ISNB, MCSN, NHMW, MNHN, ZMHB); Sardinia (HNHM); Toscana (MCSN, SMTD). Spain: Andalucía (ISNB, MHNG, MNHN), Aragon (JFCG, MHNG, NHMW, VACH); Castilla-Leon (MHNG); Catalunya (MHNG); Madrid (MHNG). Switzerland: Genève (MHNG).

*Description.* Length 3.4-3.9 mm; forebody 1.8-2.0 mm. Light coloured species of a rather broad and convex habitus. Forebody unicolorously light reddish brown to orange, pronotum slightly lighter, abdomen brown to dark brown, segments 8-10 somewhat lighter brown. Appendages evenly light brown. Punctuation distinct, rather fine and spacious on pronotum, on elytra with separate punctures and not as granular as in related species. Reticulation omits completely, forebody therefore distinctly shining. Head trapezoid with tempora notably widened, hind angles distinct and with a straight or slightly concave posterior margin, as long as wide or just up to a tenth longer than wide and just about a tenth wider than the rather broad pronotum. Eyes rather large, about half as long as tempora. Elytra rather broad and convex, laterally exceeding pronotal length by about a fifth, at suture about as long as pronotum. Membranous wings entire. Protarsomeres 1-4 in both sexes twice as wide as long. Mesotibia remarkably dilated, distinctly less than five times as long as wide. Distal antennomeres discernibly transverse. Laterotergite 9 (fig. 24) having a very slight, apico-dorsal dilatation. Male sternite 8 (fig. 19) with a rather short triangular emargination in just the apical fifth and two lateral, lighter coloured, broad impressions lacking the fine basic setae but studded with only stronger setae, and divided by a broad, slightly elevated middle field, which bears laterally orientated setae. Aedeagus (figs 10-12) with lobes asymmetrical apically. Apical lobes slightly shorter than the phallobase, strongly

FIGS 7-12

*Scopaeus ponticus* sp. n., ♂ holotype: aedeagus in 7) lateral, 8) ventral, 9) dorsal view. *Scopaeus rubidus*, ♂, France, Isère: aedeagus in 10) lateral, 11) ventral, 12) dorsal view. Scale bar = 0.1 mm.



7

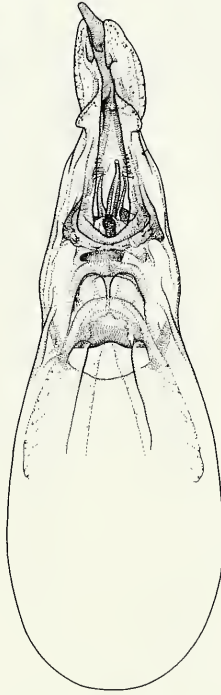

8

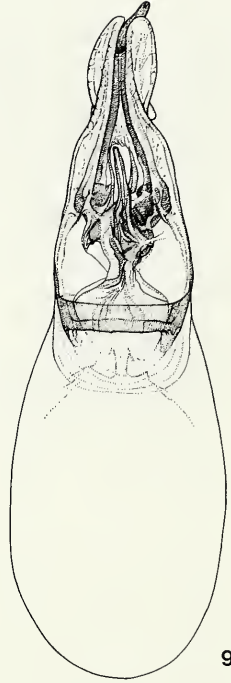

9

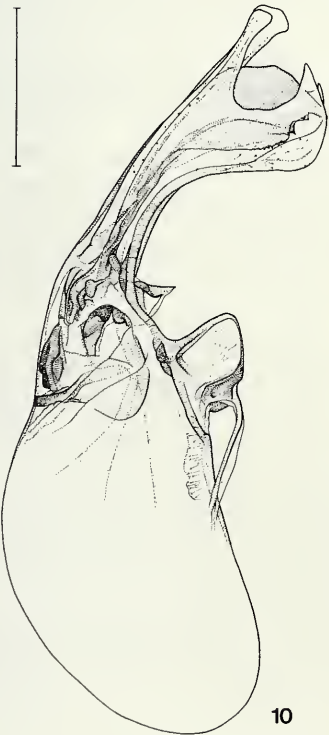

10

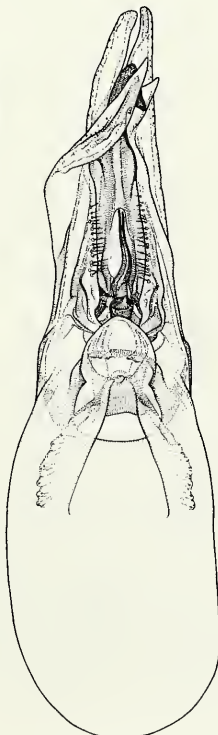

11

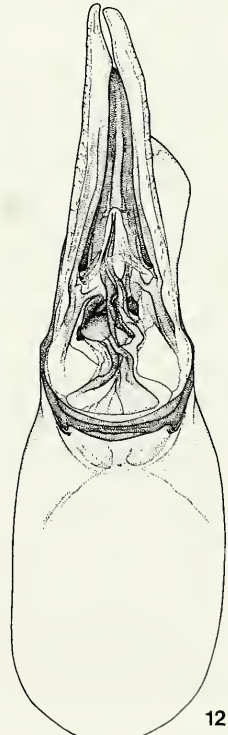

12

dilated ventrally in the distal half, apically deeply emarginate, each forming a slender, apically truncate and somewhat dilated dorsal projection and a broad, acuminate, distally bent ventral projection, which are notably bent to the right in ventral view. Apical lobes slender and evenly narrowed with asymmetrical apices in dorsal view, ventral inner margins each bearing a long row of about 15-20 short setae. In dorsal view the right lobe is strongly dilated ventro-laterally in the basal half. Dorsal lobe slender at the base but evenly bent ventrally and strongly dilated toward the apex, not projecting from the distal and the ventral margins of the apical lobes but from the deep apical emargination, serrate apico-ventrally and extended apically into an acute spine, which is bent to the right in ventral view. A short, triangular spine projects ventrally from the basis of the apical lobes. Phallobase without lateral setae, but with a remarkably prominent, ventral extension. Spermatheca (fig. 36) with members rather straight in lateral view. Chamber strongly triangular, process slender.

*Ratios.* HLW 1.04-1.11; PLW 1.15-1.25; HPW 1.06-1.13; HPL 0.95-1.01; PSL 0.95-1.07; PLL 0.77-0.85; ELW 1.16-1.28; ET 0.48-0.55; MT 4.2-4.7; A 2.5, 1.4, 1.5, 1.4, 1.3, 1.1, 0.9, 0.9, 0.8, 0.8, 1.6; T 2.0; V(♀) 5.2.

*Distribution.* *Scopaeus rubidus* is distributed in Western Europe and in the West Mediterranean region. The species was recorded repeatedly from the north of France (Maine-et-Loire: ABOT 1928; Champagne: COIFFAIT 1984; Aubé, Allier: FAUVEL 1872; Paris: SAINTE-CLAIRE DEVILLE 1907), and a specimen from Aube was examined. *Scopaeus rubidus* is confirmed throughout France and Spain southwards to Andalusia, but has not been recorded from the west of the Iberian Peninsula (Galicia, Portugal). Eastwards, the known range reaches from the southern Rhine valley (Strasbourg: COIFFAIT 1984) and Genève along the South Alps over the Apennines, where it is confirmed southwards to Lazio and Abruzzi. *Scopaeus rubidus* occurs on Sardinia but is unknown from Corsica, Sicily, the Balearic Islands and North Africa.

The occurrence of *S. rubidus* in Germany is doubtful. Ancient authors recorded the species from South Germany (BERNHAEUER & SCHUBERT 1910, GANGLBAUER 1895, HORION 1965, REITTER 1909, SCHEERPELTZ 1925) and South Bavaria (HORION 1965, KRAATZ 1858), but no specimens from Germany were available from relevant collections. Regarding the confirmed distribution pattern, the record from the upper Rhine valley (South Baden: HORION 1965) is plausible.

Records from Austria (REDTENBACHER 1874, SCHEERPELTZ in HORION 1965), the Czech Republic (BOHÁČ 1985, 1993; KLIMENT 1899), Hungary (LÁSZLO 1893), Russia (FAUVEL 1872) and the Ukraine (doubted by HORION 1965) are implausible and based obviously on misidentifications. Alleged specimens from Austria (Lower Austria, Burgenland, Styria, Carinthia), which were given by SCHEERPELTZ (in HORION 1965) and which should be in his collection (NHMW), are absent there. Ancient records from Bohemia and Moravia (KLIMENT 1899) have not been confirmed by recent specimens (BOHÁČ 1985) and have already been doubted by Horion (1965). Nevertheless, BOHÁČ (1993) mentions *S. rubidus* in the Checklist of Czechoslovak Insects.

The record of a supposed ♀ of *S. rubidus* from Crete (SCHEERPELTZ 1964) has to be declined as well.

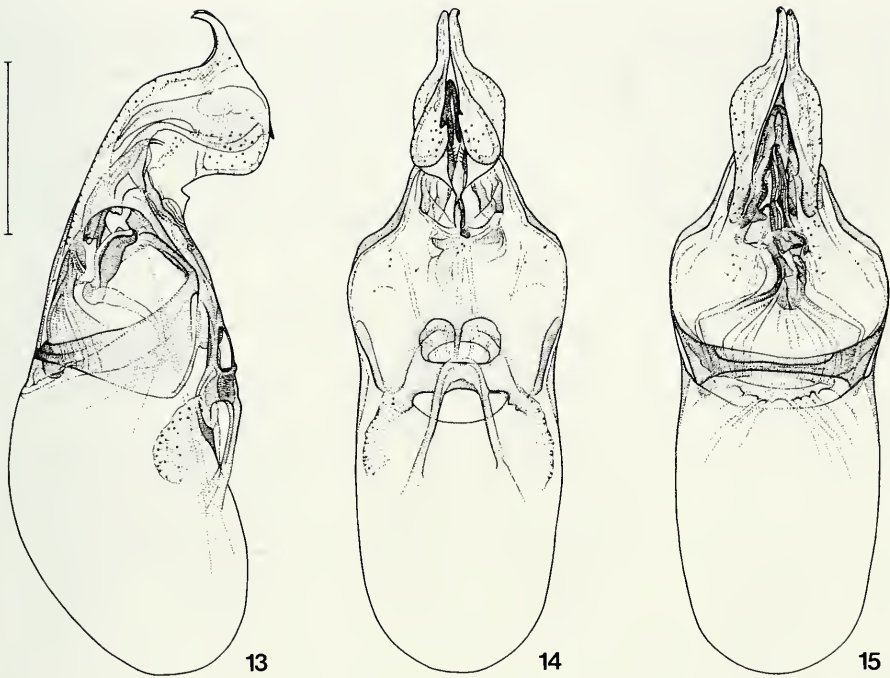

FIGS 13-15

*Scopaeus ampliatus*, ♂, Italy, Elba: aedeagus in 13) lateral, 14) ventral, 15) dorsal view. Scale bar = 0.1 mm.

The record of *S. rubidus* from Devon in South England (FOWLER 1888), which was adopted by SAINTE-CLAIRE DEVILLE (1907), refers to *S. ryei* Wollaston (NEWBERRY 1914; EDMONDS 1931, 1932; ALLEN 1968), which was described from this British region.

A specimen labelled "Danemark, Venloo" (Jarrige collection, MNHN) is possibly mislabelled. The species has not been found in Denmark (M. Hansen, Zoological Museum, Copenhagen, pers. comm.), and its occurrence so far north appears implausible.

*Comments.* COIFFAIT (1968, 1984) falsely combined *S. rubidus* with *S. gracilis* Sperk and allied species in the ill-based subgenus *Anomoscopaeus*, which he defined only by asymmetrical apical lobes, an absolute unusable feature in *Scopaeus*, which occurs in several groups of related species. In fact, *S. rubidus* does not reveal any relationship to other species of "Anomoscopaeus".

*Scopaeus subcylindricus* was described from two ♀♀ (SCRIBA 1868) collected by Seidlitz. Their origine is not given in the description, and the specimens are not traceable in the Zoologische Staatssammlung, Munich, where the Seidlitz collection

was given (HORN *et al.* 1990). The Scriba collection was bought in 1898 by K. Neumann, Bad Homburg, who later published a list of the contained types (NEUMANN 1907), in which he omits *Scopaeus subcylindricus*. On the basis of the characters given by SCRIBA (1868) for *S. subcylindricus*, its synonymy with *S. rubidus* (FAUVEL 1871) appears plausible.

**Scopaeus ampliatus** Binaghi

Figs 13-15, 20, 21, 28, 32, 37

*Scopaeus (Polyodontus) ampliatus* Binaghi, 1935: 95. Holotype ♂, Italy, Liguria, Genova, 10.1920, Dodero (MCSN); examined.

*Scopaeus (Hyposcopaeus) ampliatus*; COIFFAIT 1968: 419.

*Material examined* (15 specimens). France: Corsica (BMNH, JFCG, MNHN, NHMG). Italy: holotype ♂ and paratypes 1 ♂, 2 ♀, Liguria, Genova (MCSN); paratype ♂, Sardinia, Laconi (MCSN); Toscana (Elba) (NHMW).

*Description.* Length 3.0-3.2 mm; forebody 1.5-1.7 mm. Forebody unicolorously brown to dark brown, pronotum slightly lighter, abdomen blackish brown, segments 8-10 somewhat lighter brown. Appendages evenly light brown. Punctuation and reticulation as in *S. rubidus*, but elytra in some specimens with rather granular punctuation and weak reticulation. Head trapezoid with tempora notably widened, hind angles distinct and with a slightly to distinctly concave posterior margin, slightly or up to a tenth longer than wide and up to 0.17 times wider than pronotum. Eyes about half as long as tempora. Elytra relatively short, laterally about as long as pronotum or exceeding pronotal length by just almost a fifth, at suture slightly or up to almost a fifth shorter than pronotum. Membranous wings entire. Protarsomeres 1-4 in both sexes twice as wide as long. Mesotibia slightly dilated, about five to six times as long as wide. Distal antennomeres discernibly transverse. Laterotergite 9 (fig. 21) with a small, apico-dorsal tooth. Male sternite 8 (fig. 20) with a triangular emargination in the apical fourth having the proximal end rather rounded, but without lateral impressions and elevated midline. Lobes of the aedeagus (figs 13-15) slightly asymmetrical and somewhat bent to the right in dorsal view. Apical lobes short and stubby, strongly bent ventrally, each bearing a small, ventro-basal, triangular tooth and a long, dorsally curved apical spine, their ventral margins rather obtuse. Basal two-thirds of the apical lobes asymmetrically convex, afterwards strongly narrowed and parallel toward the apex in dorsal view. Outer margins of the apical lobes strongly convex and evenly narrowed toward the apex in ventral view, their inner ventral margins each bearing a row of about five short setae. Dorsal lobe slender at the base, strongly bent ventrally, claviform dilated distally and deeply divided ventrally into two lateral halves, each bearing an acute, apical tooth which is somewhat protruding from the ventral margins of the apical lobes. Phallobase without lateral setae, somewhat dilated distally and afterwards strongly narrowed toward the apical lobes. Spermatheca (fig. 37) with members somewhat bent and strongly triangular.

*Ratios.* HLW 1.05-1.12; PLW 1.19-1.26; HPW 1.09-1.17; HPL 0.97-1.02; PSL 1.05-1.18; PLL 0.83-0.94; ELW 1.06-1.25; ET 0.46-0.57; MT 5.0-5.8; A 2.3, 1.6, 1.3, 1.1, 1.1, 1.0, 0.9, 0.9, 0.8, 0.8, 1.5; T 2.0; V (♀) 5.3.

*Distribution.* *Scopaeus ampliatus* is recorded reliably only from North-West Italy (Liguria, Toscana), Elba, Corsica and Sardinia.

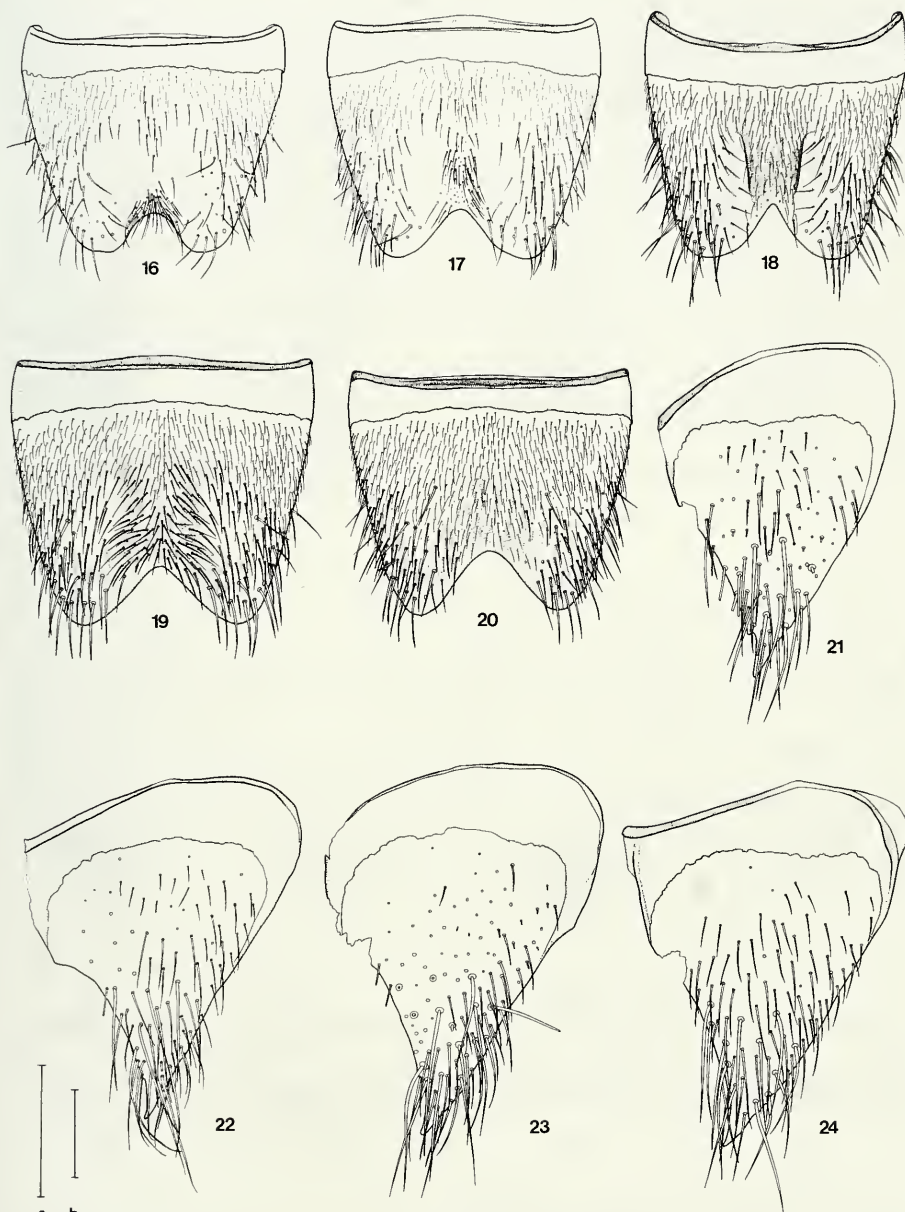

Figs 16-24

Sternite 8, ♂: 16) *Scopaeus sulcicollis*, Bosnia; 17) *S. argonauta*, Caucasus; 18) *S. ponticus* sp. n., holotype; 19) *S. rubidus*, France, Isère, 20) *S. ampliatus*, Italy, Elba. - Laterotergite 9, ♀: 21) *S. ampliatus*, paratype, Italy, Genova; 22) *S. argonauta*, Caucasus; 23) *S. ponticus* sp. n., paratype; 24) *S. rubidus*, Spain, Segovia. Scale bars: a = 0,1 mm (Figs 16-20); b = 0,1 mm (Figs 21-24).

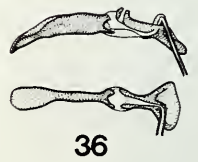
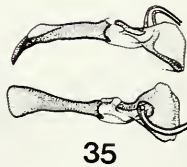
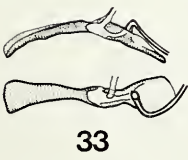
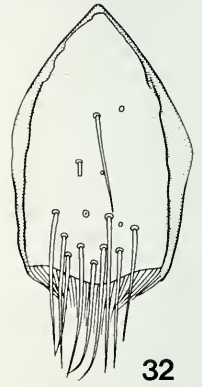
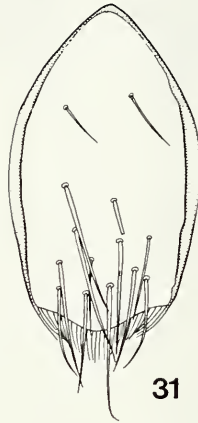
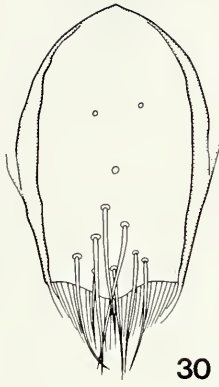
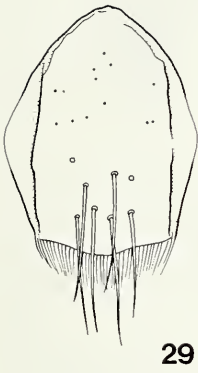
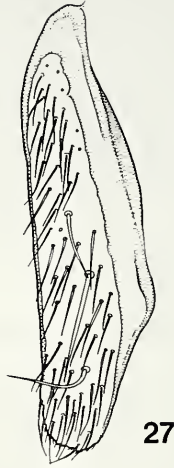
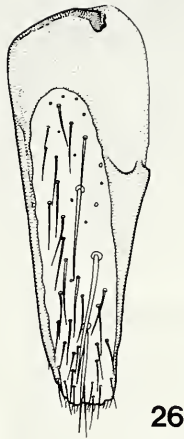
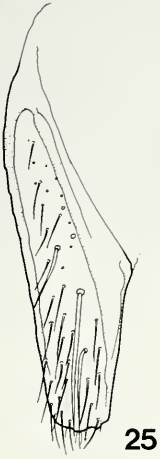



*Comments.* *Scopaeus ampliatus* and *S. rubidus* share a similar shape of the dorsal lobe of the aedeagus, which is conspicuously dilated toward the apex, and appear related closely. Both species occur sympatrically in Tuscany, Liguria and Sardinia.

#### ACKNOWLEDGEMENTS

My sincere thanks are due to the following colleagues for the loan of material from the respective institutes: N. Berti, MNHN; M. J. D. Brendell, BMNH; J. Clary, MHNL; D. Drugmand, ISNB; O. Jäger, SMTD; M. Kahlen, TLMF; A. G. Kirejtshuk, ZMAL; I. Löbl, MHNG; R. Poggi, MCSN; H. Schillhammer, NHMW; E. Sprecher, FCNB; G. Szél, HNHM; M. Uhlig, ZMHB and L. Zerche, DEIC. Specimens from private collections were provided by V. Assing, Hannover, and V. Gusarov, St. Petersburg. I thank also P. M. Hammond, BMNH, for proof-reading the manuscript. In particular I am indebted to I. Löbl, MHNG, and V. Wolters, University of Gießen, who kindly supported my work in many ways. This paper is part of a Ph. D. thesis at the University of Gießen and was supported by the Studienstiftung des Deutschen Volkes, Bonn-Bad Godesberg.

#### REFERENCES

- ABOT, G. 1928. Catalogus des Coléoptères observés dans le département de Maine-et-Loire. Paris, 386 pp.
- ALLEN, A. A. 1968. Notes on some British Staphylinidae (Col. ). 1. The genus *Scopaeus* Er. with the addition of *S. laevigatus* Gyll. to our list. *Entomologist's monthly magazine* 104: 198-207.
- BERNHAEUER, M. & SCHUBERT, K. 1910: Staphylinidae 1. - In: JUNK W. & SCHENKLING, S. (eds): Coleopterorum Catalogus 19. Berlin, 86 pp.
- BINAGHI, G. 1935. Studio sul genere *Scopaeus* Erich. (Coleopt.: Staphylin.). *Memorie della Società Entomologica Italiana* 14: 84-115.
- BOHAC, J. 1985. Review of the subfamily Paederinae (Coleoptera, Staphylinidae) in Czechoslovakia. Part II. *Acta entomologica bohemoslovaca* 82: 431-467.
- BOHAC, J. 1993. Staphylinidae. - In: JELINEK, J. 1993: Check-list of Czechoslovak Insects 4 (Coleoptera). *Folia Heyrovskyana, Suppl.* 1: 39-62.
- COIFFAIT, H. 1960. Démembrement du genre *Scopaeus* et description de 4 espèces nouvelles (Coleopt.: Staphylinidae). *Revue française d'Entomologie* 27: 283-290.
- COIFFAIT, H. 1968. *Scopaeus* nouveaux ou mal connus de la région paléarctique occidentale. *Bulletin de la Société d'Histoire naturelle de Toulouse* 104: 405-426.
- COIFFAIT, H. 1984. Coléoptères Staphylinides de la région paléarctique occidentale V: Sous-famille Paederinae Tribu Paederini 2. Sous-famille Euaesthetinae. *Publications de la Nouvelle Revue d'Entomologie* VIII, 424 pp.

#### FIGS 25-37

Valve, ♀: 25) *Scopaeus argonauta*, Caucasus; 26) *S. ponticus* sp. n., paratype; 27) *S. rubidus*, Spain, Segovia; 28) *S. ampliatus*, paratype, Italy, Genova. - Tergite 10, ♀: 29) *Scopaeus argonauta*, Caucasus; 30) *S. ponticus* sp. n., paratype; 31) *S. rubidus*, Spain, Segovia; 32) *S. ampliatus*, paratype, Italy, Genova. - Spermatheca: 33) *S. sulcicollis*, Bosnia; 34) *Scopaeus argonauta*, Caucasus; 35) *S. ponticus* sp. n., paratype; 36) *S. rubidus*, Spain, Segovia; 37) *S. ampliatus*, paratype, Italy, Genova. Scale bar = 0,1 mm.

- EDMONDS, T. H. 1931. The British species of the genus *Scopaeus* Er. (Coleoptera, Staphylinidae). *Entomologist's Monthly Magazine* 67: 272-275.
- EDMONDS, T. H. 1932. Some further notes on the genus *Scopaeus* Er. (Coleoptera, Staphylinidae) and an addition to the British list. *Entomologist's Monthly Magazine* 68: 206-209.
- FAUVEL, A. 1871. Décades Synonymiques. *L'Abeille* 7: 136.
- FAUVEL, A. 1872. Fauna gallo-rhénane 1. *Bulletin de la Société Linnéenne de Normandie* 2 (7): 8-132.
- FOWLER, W. W. 1888. The Coleoptera of the British Islands. A Descriptive Account of the Families, Genera and Species Indigenous to Great Britain and Ireland, with Notes as to Localities, Habitats, etc., Vol. II. *London*. 444 pp., pls 37-70.
- FRISCH, J. 1994. Neue Arten der Gattung *Scopaeus* Erichson aus Griechenland, Anatolien und dem Iran (Coleoptera, Staphylinidae, Paederinae). 1. Beitrag zur Kenntnis der Gattung *Scopaeus* Erichson. *Coleoptera* 2: 1-46.
- FRISCH, J. 1996. Revision westmediterraner *Scopaeus* - Arten (Coleoptera, Staphylinidae: Paederinae) und Beschreibung einer neuen Art aus Südspanien und Marokko. 2. Beitrag zur Kenntnis der Gattung *Scopaeus* Erichson. *Revue suisse de Zoologie* 103: 301-318.
- FRISCH, J. 1997. A revision of some West Palaearctic species of *Scopaeus* Erichson (Coleoptera, Staphylinidae, Paederinae). *Revue suisse de Zoologie* 104: 523-557.
- FRISCH, J. 1998. A revision of some West Palaearctic species of *Scopaeus* Erichson (Coleoptera, Staphylinidae, Paederinae). *Revue suisse de Zoologie* 105: 89-124.
- GANGLBAUER, L. 1895. Die Käfer von Mitteleuropa 2: Familienreihe Staphylinidae. 1. Theil: Staphylinidae, Pselaphidae. *Wien*, 880 pp.
- GUSAROV, V. 1992. New and little known Palaearctic Staphylinids (Coleoptera, Staphylinidae). *Entomologicheskoe Obozrenie* 71 (4): 775-788, 951.
- HEYDEN, L. v., REITTER, E. & WEISE, J. 1891. Catalogus Coleopterorum Europae, Caucasi et Armeniae rossicae. *Berlin, Mödling, Caen*, 420 pp.
- HEYDEN, L. v., REITTER, E. & WEISE, J. 1906. Catalogus Coleopterorum Europae, Caucasi et Armeniae rossicae. *Berlin, Paskau, Caen*, 774 pp.
- HORION, A. 1965. Faunistik der mitteleuropäischen Käfer X: Staphylinidae 2. Teil: Paederinae bis Staphylininae: *Überlingen*, 335 pp.
- HORN, W., KAHLE, I., FRIESE, G. & GAEDICKE, R. 1990. Collectiones entomologicae. Ein Kompendium über den Verbleib entomologischer Sammlungen der Welt bis 1960. *Akademie der Landwirtschaftswissenschaften der Deutschen Demokratischen Republik, Berlin*, part 1, 220 pp., part 2, 573 pp.
- KLIMENT, J. 1899. Cesti brouci. Dilo o broucih Cech, Moravy a Slezska. *Nem. Brod*, 811 pp., 46 + 4 pl.
- KRAATZ, G. 1856-1858. Naturgeschichte der Insecten Deutschlands 2, Staphylinii. *Berlin*, 1080 pp. 1-376: 1856, 377-768: 1857a, 169-1080: 1857b.
- LASZLO, T. 1883. Coleoptera 2: Staphylinidae 5. *Fauna Hungariae* 155, 69 pp.
- LOHSE, G. A. 1964. Staphylinidae 1 (Micropeplinae bis Tachyporinae). In: FREUDE, H., HARDE, K. W. & LOHSE, G. A. 1964: Die Käfer Mitteleuropas 4. *Krefeld*, 264 pp.
- MULSANT, E. & REY, C. 1854. Essai spécifique sur les *Scopaeus* des environs de Lyon. *Annales de la Société Linnéenne de Lyon* 2: 161-190.
- MULSANT, E. & REY, C. 1855. Essai spécifique sur les *Scopaeus* des environs de Lyon. *Opuscules Entomologiques* 6: 49-79.
- NEUMANN, K. 1907. Einiges über Staphylinen (Col.). Die Typen und Originale aus der Sammlung des Pfarrers D. Scriba. *Deutsche Entomologische Zeitschrift* 1907: 327-330.
- NEWBERRY, E. A. 1914. *Scopaeus rubidus* of British collections: synonymical note. *Entomologist's Monthly Magazine* 50: 91-92.
- REDTENBACHER, L. 1874. Fauna Austriaca. Die Käfer. 3. edition. *Wien*, 564 pp.

- REITTER, E. 1909. Fauna Germanica. Die Käfer des Deutschen Reiches 2. *Stuttgart*, 392 pp., 80 plates.
- SAINTE-CLAIRE DEVILLE, J. 1907. Faune des Coléoptères du bassin de la Seine 2: Staphylinoidea. *Paris*, 169 pp.
- SCHEERPELTZ, O. 1925. Staphylinidae. In: WINKLER, A. (ed.) 1924-1932: *Catalogus Coleopterorum regionis palearcticae*. *Wien*, 1698 pp.
- SCHEERPELTZ, O. 1964. Staphyliniden von der Insel Kreta (Coleoptera). *Annales Historico-naturales Musei Nationalis Hungarici* 56, *Pars Zoologica*: 296-308.
- SCRIBA, W. 1868. Neue europäische Staphylinen. *Berliner Entomologische Zeitschrift* 12: 153-160.
- STEPHENS, J. F. 1832. *Illustrations of British Entomology, a synopsis of indigenous insects containing their generic and specific distinctions*. Mandibulata, 5. *London*, 240 pp.
- UHLIG, M. 1989. Zur Morphologie der weiblichen Terminalia einiger Staphylinidenarten (Coleoptera). *Verhandlungen des 11. SIEEC Gotha* 1986: 227-237.



## **Abundance, species composition and phenology of Pauropoda (Myriapoda) from a secondary upland forest in Central Amazonia**

Joachim ADIS<sup>1</sup>, Ulf SCHELLER<sup>2</sup>, José Wellington de MORAIS<sup>3</sup>  
& José Maria G. RODRIGUES<sup>3</sup>

<sup>1</sup> Max-Planck-Institute for Limnology, Tropical Ecology Working Group,  
Postfach 165, D-24302 Plön, Germany.

<sup>2</sup> Höggeboholm, Häggesled, S-53194 Järpås, Sweden.

<sup>3</sup> Instituto Nacional de Pesquisas da Amazônia (INPA), C.P. 478,  
69.011-970 Manaus/AM, Brazil.

**Abundance, species composition and phenology of Pauropoda (Myriapoda) from a secondary upland forest in Central Amazonia.** - The 6,878 pauropods collected within 12 months in the soil (0-7 cm depth) of a secondary upland forest ( $1,085.7 \pm 42.3$  ind./m<sup>2</sup>/month) near Manaus were represented by 41 species of the Pauropodidae (Order Tetramerocera). The Pauropodinae were represented by 31 species, the Polypauropodinae by 6 species, and the Scleropauropodinae by 4 species. About half of all pauropod specimens obtained inhabited the organic soil layer (0-3.5 cm depth) compared to the mineral subsoil (3.5-7 cm). Abundance of pauropods in the soil was twice as high in comparison to the Symphyla from the same study site. The lack of a distinct reproductive period in eudominant and dominant pauropod species and the presence of juveniles and adults throughout the year indicate a plurivoltine mode of life. Only in one species was the monthly catch of adults positively correlated with maximum temperatures of the soil. Pauropods obtained from the soil of four other upland forests in Central Amazonia (0-14 cm depth) accounted for 1.1-4.4% of the total soil arthropods. A possible parthenogenesis found in three pauropod species is discussed.

**Key-words:** abundance - phenology - parthenogenesis - soil fauna - Pauropoda - Amazon - Neotropics.

### INTRODUCTION

Terrestrial arthropods of Central Amazonian forests have been investigated for several years (cf. ADIS & SCHUBART 1984; ADIS 1997; ADIS *et al.* 1997a,b) in a cooperative venture between the National Institute for Amazonian Research (INPA) at Manaus/Brazil and the Tropical Ecology Working Group at the Max-Planck-Institute for Limnology in Plön/Germany (Projeto INPA/Max-Planck). Data on abundance and

phenology of Pauropoda sampled during 12 months in 1982/83 in a secondary upland forest are now available, as their taxonomical evaluation has been completed (SCHELLER 1994, 1997). Our data represent the very first contribution on the abundance and phenology of Neotropical pauropod species. Voucher specimens have been deposited at the Systematic Entomology Collections of the Instituto Nacional de Pesquisas da Amazônia (INPA) in Manaus/Brazil and at the Muséum d'histoire naturelle in Geneva/Switzerland.

## STUDY AREA, MATERIAL AND METHODS

Pauropods were collected between 1981 and 1983 in the course of ecological studies on Central Amazonian arthropods from a previously investigated and fully described secondary upland forest at Rio Taramã Mirim (03°02'S, 60°17'W), a tributary of the Rio Negro near Manaus, where the vegetation was previously cut but unburned (cf. ADIS 1992, FRANKLIN *et al.* 1997). The forest is subject to a rainy season (December-May: average precipitation 1550 mm;  $258.8 \pm 36.8$  mm/month) and a "dry" season (June-November: average precipitation 550 mm;  $91.8 \pm 43.8$  mm/month, but each month with some rain events; cf. RIBEIRO & ADIS 1984). The yellow latosol (= ferrasol in JORDAN 1984) of the secondary upland forest supported a 2-3 cm thick humus layer, interspersed with fine roots, and a thin surface covering of leaf-litter. One ground photo-eclector (emergence trap with pitfall trap inside) and one arboreal photo-eclector for trunk ascents (funnel trap) were installed in the forest from December 1981 to December 1982 (see ADIS & SCHUBART 1984). The distribution of pauropods in the soil was studied between September 1982 and August 1983 (RODRIGUES 1986). Twelve soil samples were taken once a month every two meter along a randomly selected transect. The split corer composed of a steel cylinder with lateral hinges (diameter 21 cm, length 33 cm), was driven into the soil by a mallet. Each sample of 7 cm depth was then divided into two subsamples of 3.5 cm each. Animals were extracted from subsamples following a modified method of Kempson (ADIS 1987). The combined area of 12 samples represented 0.42 m<sup>2</sup>. Calculated average abundances per m<sup>2</sup> are given with sample standard deviation. The monthly collection data of pauropods from the two soil layers in relation to changing conditions of precipitation, temperature and humidity of the air near the forest floor as well as moisture content, temperature and pH of the soil were statistically evaluated with a linear, parametric correlation test (CAVALLI-SFORZA 1972) using the original field data (RODRIGUES 1986). Pauropoda (Pauropodidae) sampled were classified as juveniles (3, 5 and 6 pairs of legs), subadults (8 pairs of legs) and adults (9 pairs of legs). Sex was determined for subadults and adults.

## RESULTS

A total of 6,878 pauropods (body length  $\leq 1.50$  mm without antennae) were collected. Out of these, 90% could be identified to species and developmental stages. All pauropods were obtained by extraction of the forest soil. None were caught on the soil surface (ground photo-eclector), or on the tree trunk (arboreal photo-eclector).

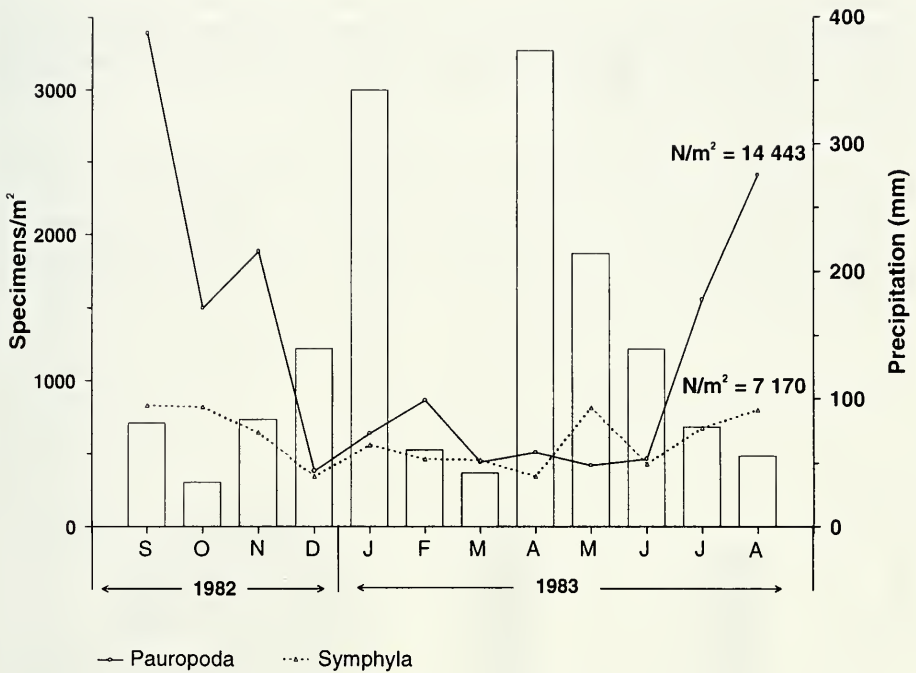

FIG. 1

Distribution of Pauropoda and Symphyla in the soil. Samples taken monthly at 0-7 cm depth between September 1982 and August 1983 in a secondary upland forest near Manaus. (N = total number of specimens). Total precipitation per month given between sampling dates (= in the middle of each month). The low rainfall observed in early 1983 was due to a strong El Niño-event (cf. ADIS & LATIF 1996).

TABLE 1

Average abundance ( $N/m^2$ ) and dominance (%) of Pauropoda genera (all representing the Pauropodidae) in the soil of a secondary upland forests near Manaus, Brazil. Samples taken monthly at 0-3.5 and 3.5-7.0 cm soil depths between September 1982 and August 1983.

PAUROPODIDAE Genus (Species)	$N/m^2$ per month			%
	0 - 3.5 cm	3.5 - 7.0 cm	0 - 7.0 cm	
<i>Allopaupopus</i> (28)	486.6 ± 24.8	509.1 ± 26.3	995.7 ± 49.6	91.7
<i>Hemipauropus</i> (2)	34.1 ± 6.6	16.4 ± 4.7	50.5 ± 10.4	4.7
<i>Polypauropus</i> (2)	17.3 ± 7.4	12.2 ± 6.0	29.5 ± 13.3	2.7
<i>Scleropauropus</i> (4)	2.0 ± 0.6	1.8 ± 0.7	3.8 ± 1.2	0.3
<i>Poly-pauropoides</i> (4)	1.4 ± 0.4	4.0 ± 0.9	5.4 ± 1.1	0.5
<i>Cauvetauropus</i> (1)	0.4 ± 0	0.4 ± 0	0.8 ± 0	0.1
<b>Total</b>	<b>541.8 ± 21.1</b>	<b>543.9 ± 22.4</b>	<b>1085.7 ± 42.3</b>	<b>100.0</b>

Pauropoda represented 6.4% of the total arthropods extracted from soil samples within 12 months (Acari & Collembola omitted; cf. RODRIGUES 1986). Their abundance in 0-7 cm soil depth was twice as high than that of the Symphyla (Fig. 1: 14,443 versus 7,170 ind./m<sup>2</sup>; cf. ADIS *et al.* 1997c). An average abundance of  $1,085.7 \pm 42.3$  pauropods/m<sup>2</sup>/month was recorded in 0-7 cm soil depth (Table 1).

About half of the pauropods obtained (49.9%) inhabited the organic soil layer (Fig. 2: 0-3.5 cm) compared to the mineral subsoil (3.5-7.0 cm depth). Of the total catch, 68.8% was represented by adults (Fig. 2), 4.6% by subadults and 26.6% by juveniles. The total catch of pauropods collected during the dry season was three times higher compared to the rainy season: 77.5% ( $1,865.2 \pm 980.5$  ind./m<sup>2</sup>/month) versus 22.5% ( $542.0 \pm 180.2$  ind./m<sup>2</sup>/month).

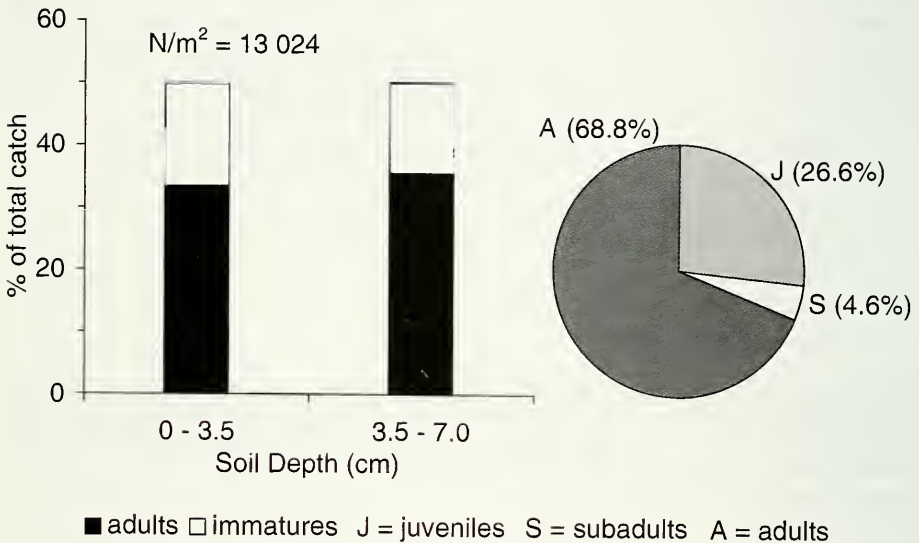

FIG. 2

Distribution of Pauropoda in the soil according to depth, and percentage of developmental stages in a secondary upland forest near Manaus. (Total catch = 100%). Samples taken monthly at 0-3.5 and 3.5-7 cm depths between September 1982 and August 1983. (N = total number of specimens).

The pauropods collected from the secondary upland forest represented 41 species of the family Pauropodidae (Order Tetramerocerata). Out of these, 38 were new (SCHELLER 1994, 1997) and only 3 known (Table 2). *Allopaupopus*, *Hemipauropus* and *Cauvetauropus* represented the subfamily Pauropodinae (31 species), *Polypauropus* and *Polypauropoides* the subfamily Polypauropodinae (6 species), and *Scleropauropus* the subfamily Scleropauropodinae (4 species). Out of the six genera obtained (Tables 1, 2), *Allopaupopus* (28 species) represented 91.7% of the total catch, *Hemipauropus* (2 species) 4.6%, and *Polypauropus* (6 species) 2.7%. Representatives of the genus *Allopaupopus* were as abundant in the organic soil layer as in the mineral subsoil



TABLE 2

Average abundance ( $N/m^2$ ) and dominance (%) of Pauropoda species (all representing the Pauropodidae) in the soil of a secondary upland forests near Manaus, Brazil. Samples taken monthly at 0-3.5 and 3.5-7.0 cm soil depths between September 1982 and August 1983.

No.	Species	Subf.	$N/m^2$ per month			%
			0 - 3.5 cm	3.5 - 7.0 cm	0 - 7.0 cm	
1	<i>Allopauropus</i> (A.) <i>rodriguesi</i> Sch.	Pau.	174.0 ± 233.3	184.1 ± 223.1	358.1 ± 441.2	33.0
2	<i>Allopauropus</i> (D.) <i>bicornutus</i> Sch.	Pau.	78.4 ± 94.9	126.9 ± 153.4	205.3 ± 238.7	18.9
3	<i>Allopauropus</i> (D.) <i>proximus</i> Remy	Pau.	48.3 ± 76.8	11.6 ± 14.1	59.9 ± 88.7	5.5
4	<i>Allopauropus</i> (A.) <i>dundoensis</i> Remy	Pau.	31.3 ± 49.5	22.1 ± 31.1	53.4 ± 79.1	4.9
5	<i>Allopauropus</i> (A.) <i>tenuis</i> Remy	Pau.	27.7 ± 35.7	22.6 ± 29.0	50.3 ± 63.6	4.6
6	<i>Allopauropus</i> (A.) <i>ovalis</i> Sch.	Pau.	22.9 ± 18.0	24.8 ± 22.3	47.7 ± 34.2	4.4
7	<i>Allopauropus</i> (D.) <i>manausensis</i> Sch.	Pau.	23.5 ± 17.0	23.1 ± 10.9	46.6 ± 29.0	4.3
8	<i>Allopauropus</i> (A.) <i>bicorniculatus</i> Sch.	Pau.	10.6 ± 11.1	33.5 ± 24.4	44.1 ± 29.2	4.1
9	<i>Hemipauropus</i> <i>piriformis</i> Sch.	Pau.	24.3 ± 18.9	9.9 ± 11.9	34.2 ± 29.5	3.1
10	<i>Allopauropus</i> (D.) <i>adisi</i> Sch.	Pau.	15.4 ± 13.0	13.8 ± 9.4	29.2 ± 20.7	2.7
11	<i>Polyauropus</i> <i>tropicus</i> Sch.	Pol.	16.2 ± 23.1	12.0 ± 19.2	28.2 ± 41.7	2.6
12	<i>Allopauropus</i> (D.) <i>anomoios</i> Sch.	Pau.	9.1 ± 13.5	12.8 ± 14.6	21.9 ± 27.0	2.0
13	<i>Allopauropus</i> (D.) <i>ieenus</i> Sch.	Pau.	10.6 ± 12.7	7.2 ± 14.8	17.8 ± 25.7	1.6
14	<i>Hemipauropus</i> <i>amazonicus</i> Sch.	Pau.	9.9 ± 7.9	6.5 ± 10.7	16.4 ± 17.1	1.5
15	<i>Allopauropus</i> (D.) <i>brachypodus</i> Sch.	Pau.	6.4 ± 10.1	3.4 ± 6.0	9.8 ± 11.8	0.9
16	<i>Allopauropus</i> (A.) <i>uncinatus</i> Sch.	Pau.	4.8 ± 8.2	4.4 ± 7.2	9.2 ± 13.7	0.8
17	<i>Allopauropus</i> (D.) <i>petiolatus</i> Sch.	Pau.	3.6 ± 4.8	5.2 ± 10.1	8.8 ± 12.0	0.8
18	<i>Allopauropus</i> (D.) <i>irmgardae</i> Sch.	Pau.	3.2 ± 5.1	4.4 ± 5.8	7.6 ± 8.2	0.7
19	<i>Allopauropus</i> (D.) <i>pedicellus</i> Sch.	Pau.	5.6 ± 5.8	1.8 ± 2.7	7.4 ± 5.8	0.7
20	<i>Allopauropus</i> (D.) <i>junki</i> Sch.	Pau.	5.6 ± 7.9	1.0 ± 1.9	6.6 ± 8.9	0.6
21	<i>Allopauropus</i> (D.) <i>neotropicus</i> Sch.	Pau.	1.2 ± 2.2	2.6 ± 2.9	3.8 ± 4.6	0.4
22	<i>Allopauropus</i> (D.) <i>tohoius</i> Sch.	Pau.	1.8 ± 4.3	1.0 ± 2.2	2.8 ± 6.0	0.3
23	<i>Scleropauropus</i> <i>tarumamirimi</i> Sch.	Scl.	1.2 ± 0.4	1.6 ± 0.4	2.8 ± 5.1	0.3
24	<i>Allopauropus</i> (D.) <i>sinuosus</i> Sch.	Pau.	1.4 ± 2.9	0.4 ± 0.4	1.8 ± 3.6	0.2
25	<i>Polyauropoides</i> <i>biclaviger</i> Sch.	Pol.	0.6 ± 1.2	1.0 ± 2.4	1.6 ± 2.9	0.1
26	<i>Polyauropoides</i> <i>foliolus</i> Sch.	Pol.	0.6 ± 1.4	1.0 ± 2.2	1.6 ± 2.9	0.1
27	<i>Polyauropoides</i> <i>unisetus</i> Sch.	Pol.	-	1.6 ± 2.9	1.6 ± 2.9	0.1
28	<i>Allopauropus</i> (D.) <i>dischides</i> Sch.	Pau.	0.8 ± 1.7	0.6 ± 1.4	1.4 ± 2.4	0.1
29	<i>Polyauropus</i> <i>latebricolus</i> Sch.	Pol.	1.0 ± 2.2	0.2 ± 0.7	1.2 ± 2.2	0.1
30	<i>Cauvetauropus</i> (P.) <i>biglobulosus</i> Sch.	Pau.	0.4 ± 1.4	0.4 ± 1.0	0.8 ± 1.7	0.1
31	<i>Allopauropus</i> (D.) <i>acer</i> Sch.	Pau.	0.2 ± 0.7	0.6 ± 1.0	0.8 ± 1.4	0.1
32	<i>Polyauropoides</i> <i>naous</i> Sch.	Pol.	0.2 ± 0.7	0.4 ± 1.4	0.6 ± 2.2	0.1
33	<i>Allopauropus</i> (D.) <i>aius</i> Sch.	Pau.	-	0.4 ± 1.0	0.4 ± 1.0	>0.1
34	<i>Scleropauropus</i> <i>beritae</i> Sch.	Scl.	0.4 ± 1.4	-	0.4 ± 1.4	>0.1
35	<i>Scleropauropus</i> <i>rimatus</i> Sch.	Scl.	0.2 ± 0.7	0.2 ± 0.7	0.4 ± 1.4	>0.1
36	<i>Allopauropus</i> (D.) <i>campinaranicus</i> Sch.	Pau.	0.2 ± 0.7	-	0.2 ± 0.7	>0.1
37	<i>Allopauropus</i> (D.) <i>korynetes</i> Sch.	Pau.	-	0.2 ± 0.7	0.2 ± 0.7	>0.1
38	<i>Allopauropus</i> (D.) <i>hylaos</i> Sch.	Pau.	-	0.2 ± 0.7	0.2 ± 0.7	>0.1
39	<i>Allopauropus</i> (D.) <i>mirimus</i> Sch.	Pau.	-	0.2 ± 0.7	0.2 ± 0.7	>0.1
40	<i>Allopauropus</i> (D.) <i>tenuilobatus</i> Sch.	Pau.	-	0.2 ± 0.7	0.2 ± 0.7	>0.1
41	<i>Scleropauropus</i> <i>fissus</i> Sch.	Scl.	0.2 ± 0.7	-	0.2 ± 0.7	>0.1
Total			541.8 ± 21.1	543.9 ± 22.4	1085.7 ± 42.3	100.0

Subf. = Subfamily, Pau. = Pauropodinae, Pol. = Polypauropodinae, Scl. = Scleropauropodinae

(48.9% versus 51.1%; Fig. 3; top; Table 1). Species representing the genus *Hemipauropus* (Fig. 3) were somewhat more abundant in the organic layer (0-3.5 cm: 67.5% of the total catch; Table 1), whereas representatives of the genus *Polyauropoides* (Table 1) were more abundant in the mineral subsoil (3.5-7 cm: 74.1%). Out of the total 41 pauropod species, 3 species were only obtained from the organic soil layer and 5

solely from the mineral subsoil (Table 3, Fig. 3: bottom). Three species of the genus *Allopauporus* represented more than half (57.4%) of the total pauropods collected in 0-7 cm soil depth, 27% in the organic soil layer (0-3.5cm) and 30% in the mineralic subsoil (3.5-7cm; Fig. 3: bottom, Table 1).

*Allpauropus rodriguesi* and *A. bicornutus* were eudominant, representing 33.0% (4,296 ind./m<sup>2</sup>) and 18.9% (2,460 ind./m<sup>2</sup>) of the total catch, respectively (Fig. 4, Table 1). Adult specimens predominated in both species (61.9 and 83.3%, respectively), regardless of the soil layer investigated (Fig. 4), whereas subadults were rare (<2%). Juvenile specimens were more abundant in *A. rodriguesi* (37.3% of the total catch) compared to *A. bicornutus* (14.9%). *A. rodriguesi* was likewise abundant in both soil layers (Table 1, Fig. 4), despite its large body size ( $\leq 1.41$ mm) and relatively long legs. *A. bicornutus* was smaller ( $\leq 0.83$ mm) and somewhat more abundant in the mineral subsoil (3.5-7cm: 62% of the total catch) compared to the organic soil layer (0-3.5cm).

The next two dominant species, *A. proximus* and *A. dundoensis* (Fig. 4, Table 1), represented 5.5% (719 ind./m<sup>2</sup>) and 4.9% (638 ind./m<sup>2</sup>) of the total catch, respectively. Adults dominated in both soil layers (Fig. 4; total catch: 84.3 and 75.1%, respectively). Subadults were more abundant in *A. dundoensis* (10.8%) compared to *A. proximus* (1.7%). *A. proximus* was more abundant in the organic soil layer (80.6%) compared to the mineral subsoil (Fig. 4: 3.5-7 cm). No males were obtained in *A. dundoensis*, and only two males each in *A. proximus* and *A. tenuis*.

Only in *Allopauporus proximus* was the monthly abundance of adults (250 females, 2 males) in both soil layers positively correlated with maximum soil temperatures (25.1-29.3 °C; average:  $25.3 \pm 0.7$  °C), i.e. catch numbers increased with increasing temperatures (total catch:  $r=+0.85055$  (0-3.5cm),  $r=+0.81230$  (3.5-7cm),  $p<0.01$ ;  $n=12$ ). For all other species no significant correlations were obtained ( $p\leq 0.01$ ) between the monthly abundances in the soil and the local abiotic factors.

Although the total catches of dominant species obtained during the dry season were generally higher compared to the rainy season, there was no distinct reproductive period because juveniles as well as adults occurred throughout the year (cf. Figs 5-7 for *Allopauporus rodriguesi*, *A. bicornutus*, *A. ovalis*, *A. manauensis*, *A. bicornulus* and *Hemipauropus piriformis*). These results indicate a plurivoltine mode of life.

## DISCUSSION

### ABUNDANCE AND VERTICAL DISTRIBUTION

Further comparable data on the abundance and vertical distribution of the soil fauna in four different upland forest types of Central Amazonia were obtained by Adis and collaborators (cf. ADIS *et al.* 1987a,b, 1989a,b; RIBEIRO 1994). Arthropods were collected to a soil depth of 14 cm during rainy and dry seasons and extracted with the Kempson method as described above. Between 75% and 92% of all arthropods were found to inhabit the top 7 cm when Acari and Collembola were included in the total catch numbers and 69%-84% when they were omitted. Data on Pauropoda are now available:

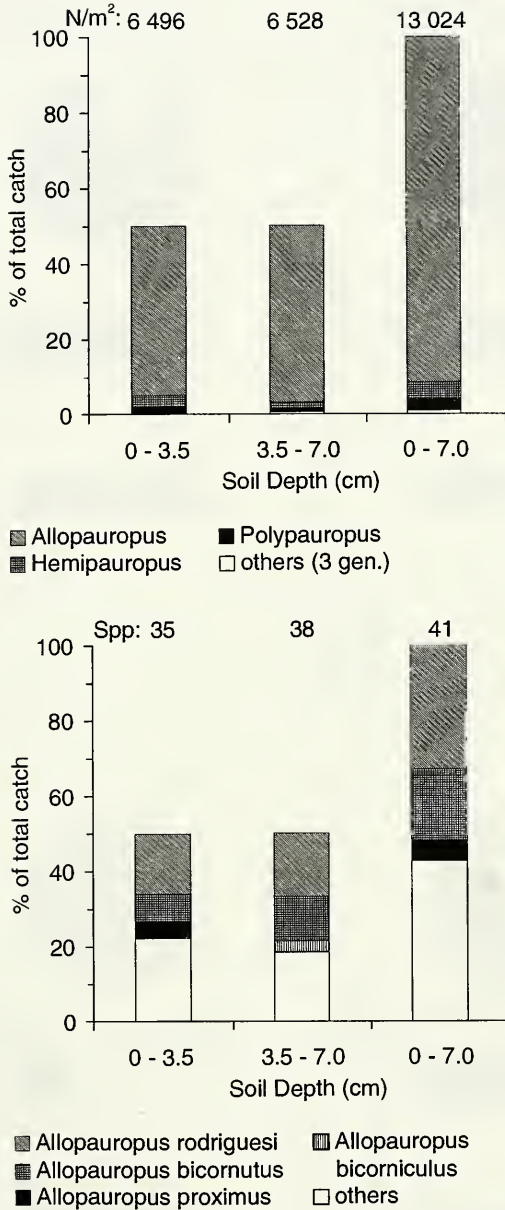
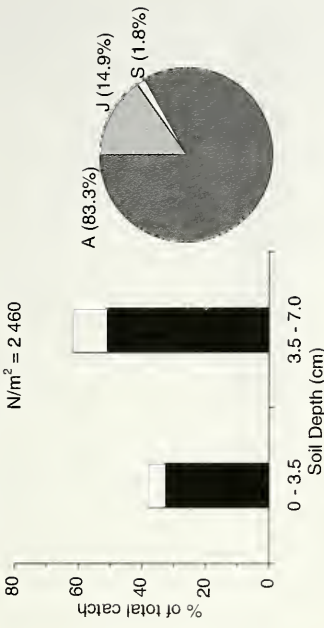

FIG. 3

Distribution of dominant genera (top) and species (bottom) of Pauropoda in the soil according to depth in a secondary upland forest near Manaus. (Total catch = 100%). Samples taken monthly at 0-3.5 and 3.5-7 cm depths between September 1982 and August 1983. (N = total number of specimens; Spp. = total number of species).

**Allopaurus bicornutus**



**Allopaurus dundoensis**

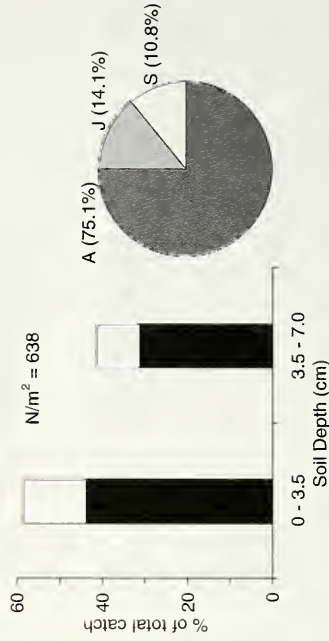

**Allopaopus rodriguessi**

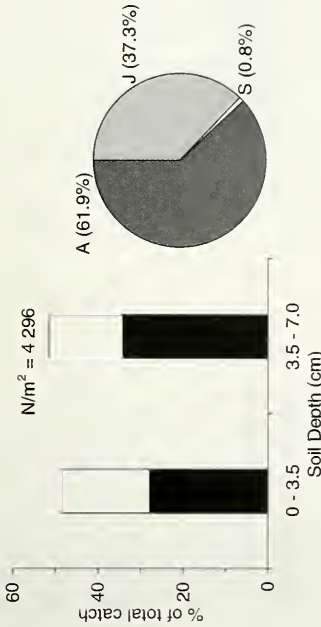

**Allopaopus proximus**

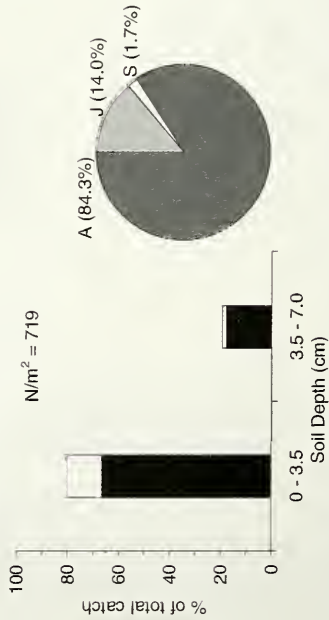

■ adults □ immatures J = juveniles S = subadults A = adults

■ adults □ immatures J = juveniles S = subadults A = adults

FIG. 4

Distribution of *Allopaopus rodriguessi*, *A. bicornutus*, *A. proximus* and *A. dundoensis* in the soil according to depth, and percentage of developmental stages in a secondary upland forest near Manaus. (Total catch = 100%). Samples taken monthly at 0-3.5 and 3.5-7 cm depths between September 1982 and August 1983. (N = total number of specimens).

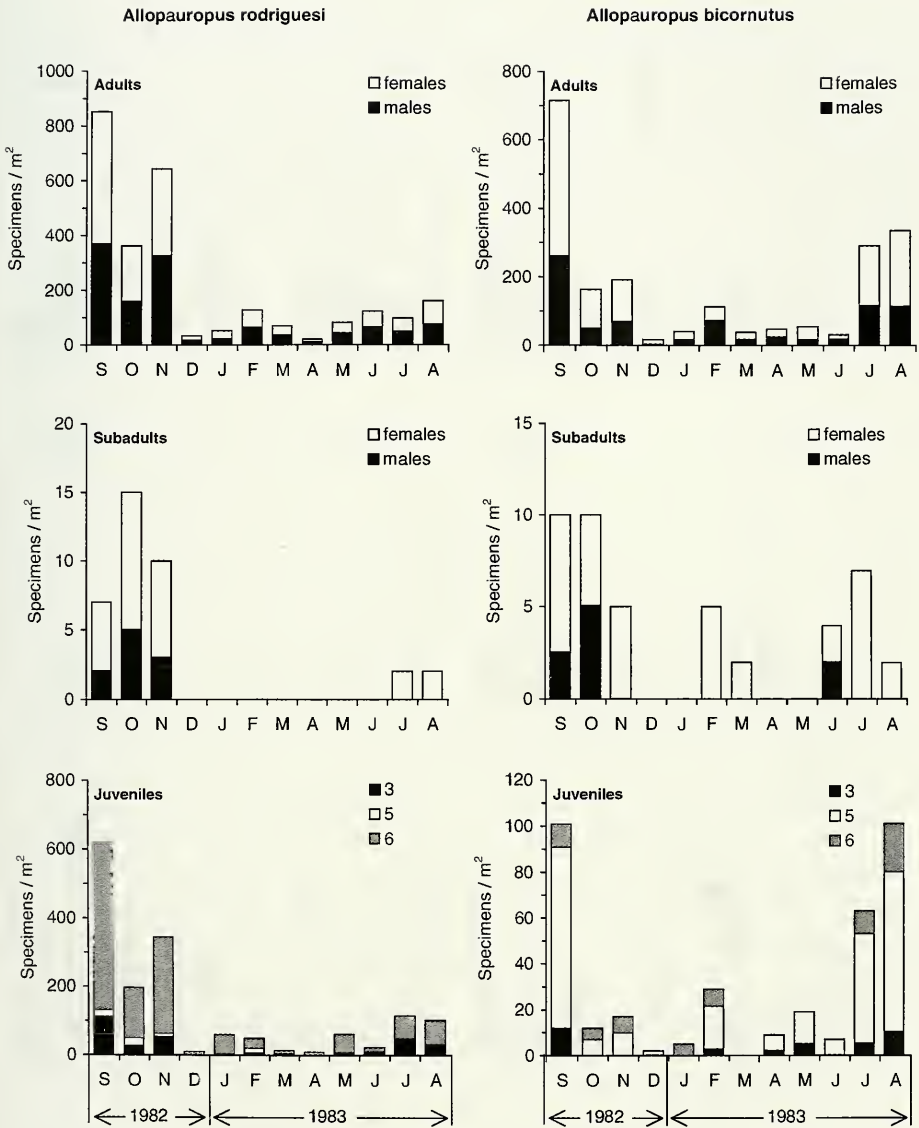

FIG. 5

Temporal occurrence of developmental stages of *Allopaupopus rodriguesi* and *A. bicornutus* in the soil (N/m<sup>2</sup> in 0-7 cm depth) of a secondary upland forest near Manaus. Monthly samples taken between September 1982 and August 1983. (Classification of juveniles according to pairs of legs).

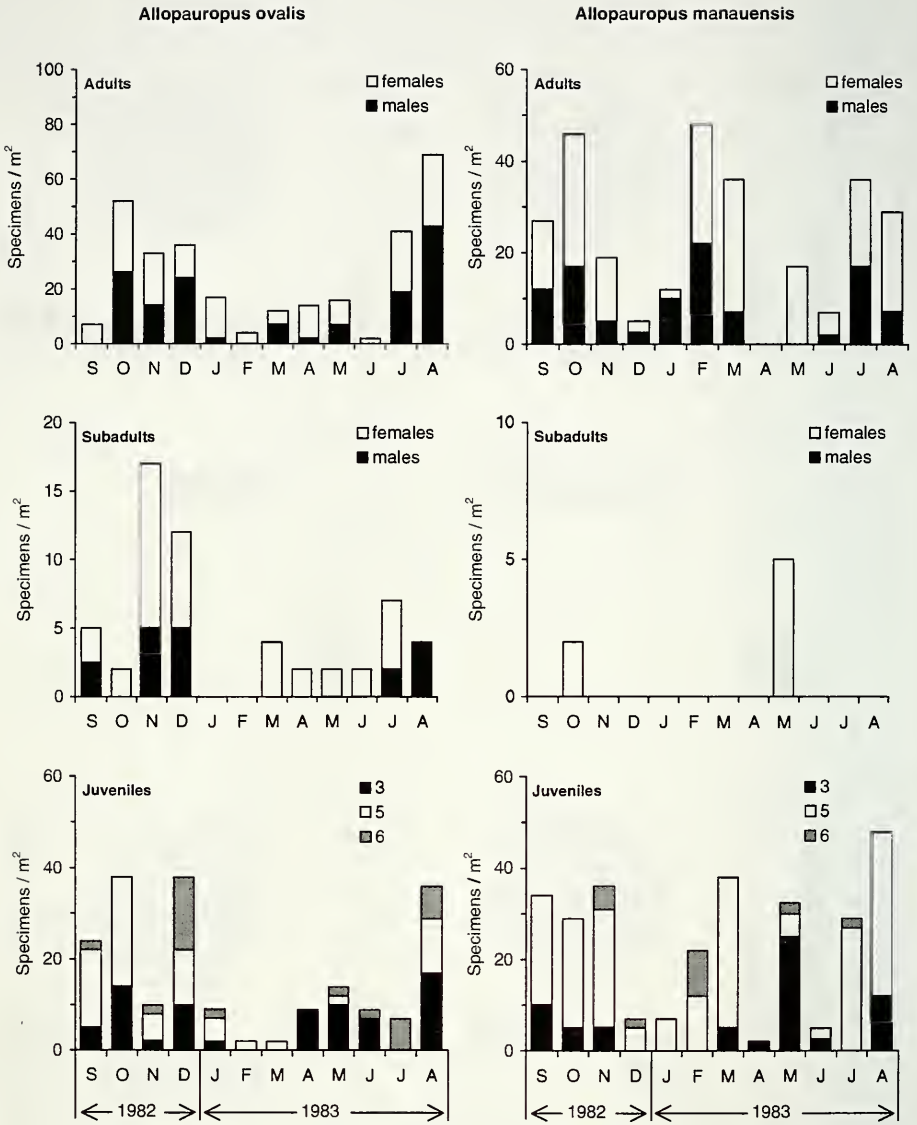

FIG. 6

Temporal occurrence of developmental stages of *Allopauporus ovalis* and *A. manauensis* in the soil (N/m<sup>2</sup> in 0-7 cm depth) of a secondary upland forest near Manaus. Monthly samples taken between September 1982 and August 1983. (Classification of juveniles according to pairs of legs).

*Allopaupopus bicorniculus*

*Hemipauropus piriformis*

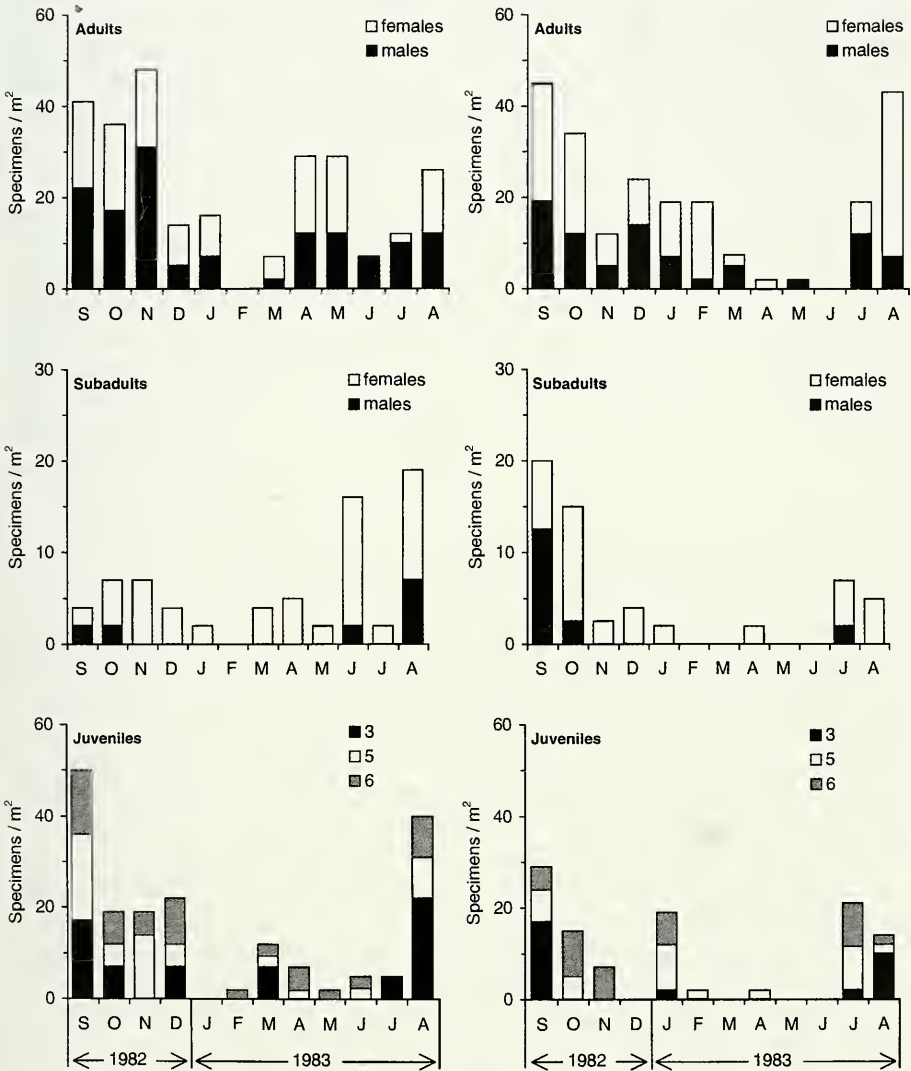

FIG. 7

Temporal occurrence of developmental stages of *Allopaupopus bicorniculus* and *Hemipauropus piriformis* in the soil ( $N/m^2$  in 0-7 cm depth) of a secondary upland forest near Manaus. Monthly samples taken between September 1982 and August 1983. (Classification of juveniles according to pairs of legs).

One study was conducted during October 1985 and April 1986 in a secondary upland forest on yellow latosol (Capoeira) at the INPA campus in Manaus (03°08'S, 60°01'W), where the vegetation was previously cut but unburned (ADIS *et al.* 1987a,b). Pauropods represented 1.1-1.6% of the total arthropods when Acari and Collembola were included (dry season: 50.448 ind./m<sup>2</sup>, rainy season: 63.850 ind./m<sup>2</sup>) and 4.6-5.8% when they were omitted from the total catch numbers (dry season: 11.934 ind./m<sup>2</sup>, rainy season: 17.886 ind./m<sup>2</sup>). The total abundance of pauropods in 0-14 cm soil depth was higher during the rainy season (1,035 ind./m<sup>2</sup>) compared to the dry season (549 ind./m<sup>2</sup>). However, during both rainy and dry seasons percentages of the total catch in the top 7 cm were similar (61.9% and 66.7%, respectively).

Another study was made from August 1990 to February 1991 in a secondary upland forest on yellow latosol (Capoeira), about 50 km north of Manaus (03°34'S, 60°06'W), where the vegetation was previously cut and burned (RIBEIRO 1994). Pauropods represented 2.5-3.5% of the total arthropods when Acari and Collembola were included (dry season (Aug.-Oct.): 29.064 ind./m<sup>2</sup>, rainy season (Dec.-Febr.): 19.793 ind./m<sup>2</sup>) and 9.4-9.8% when they were omitted from the total catch numbers (dry season: 7.720 ind./m<sup>2</sup>, rainy season: 7.176 ind./m<sup>2</sup>). The total abundance of pauropods (0-14 cm soil depth) during the rainy and dry seasons was similar (703 versus 727 ind./m<sup>2</sup>). This was also true for the percentages obtained in the top 7 cm: 42.5% of the total catch during the rainy season and 55.0% during the dry season.

A third study was made during March and August 1988 in a primary forest on whitesand soil (Campinarana), about 45 km north of Manaus (02°35'S, 60°01'W; ADIS *et al.* 1989a,b). Pauropods represented 2.8-4.4% of the total arthropods when Acari and Collembola were included (dry season: 57.703 ind./m<sup>2</sup>, rainy season: 74.255 ind./m<sup>2</sup>) and 13.8-18.1% when they were omitted from the total catch numbers (dry season: 14.119 ind./m<sup>2</sup>, rainy season: 15.023 ind./m<sup>2</sup>). The total abundance of pauropods (0-14 cm soil depth) during the rainy and dry seasons was similar and high (2,079 versus 2,550 ind./m<sup>2</sup>). This was also true for the percentages obtained in the top 7 cm: 60.4% of the total catch during the rainy season and 61.9% during the dry season.

The fourth study was conducted during April and October 1987 in the primary upland forest on yellow latosol at Reserva Ducke (ADIS *et al.*, unpubl.). Pauropods represented 1.3-1.7% of the total arthropods when Acari and Collembola were included (dry season: 38.727 ind./m<sup>2</sup>, rainy season: 25.905 ind./m<sup>2</sup>) and 4.1-4.3% when they were omitted from the total catch numbers (dry season: 11.742 ind./m<sup>2</sup>, rainy season: 11.005 ind./m<sup>2</sup>). The total abundance of pauropods (0-14 cm soil depth) during the rainy and dry seasons was similar and low (448 versus 505 ind./m<sup>2</sup>). No significant difference (Chi-square test) was found between the percentages obtained in the top 7 cm during the rainy season (62.4% of the total catch) and the dry season (84.4%).

The lack of pauropods in samples from the ground and arboreal photo-elector indicates that representatives of this group are rarely active on or above the soil surface in Central Amazonian upland forests. This conclusion is supported by two other studies in a primary upland forest of the Reserva Ducke near Manaus, in which apparently no pauropods were collected in 20 baited pitfall traps and in one or more ground photo-



ectors during a sample period of 12 months (ADIS *et al.* 1996, PENNY & ARIAS 1982) or from tree crowns by fogging canopies with pyrethrum (ADIS *et al.* 1997c).

The depth to which pauropods occur in the soil of the Central Amazonian upland forests is unknown. Our studies in various forest types near Manaus (see above) revealed their presence to a soil depth of 14 cm. SERAFINO & MERINO (1978) detected them until 20 cm soil depth in a forest and in plantations in Costa Rica. Pauropoda are, however, found to occur to a depth of at least 75 cm in other parts of the world (SCHELLER 1974). In *Allopauropus proximus* the vertical distribution was influenced by soil temperatures. In the soil of man-made pastures (0-14 cm depth) adjacent to upland forests in Central Amazonia, pauropods were only found below 7 cm soil depth. One reason might be the low humidity and high temperature of the soil around noon, particularly during the dry season (ADIS & FRANKLIN, unpubl.).

The small size of pauropods as well as inefficient sampling methods might explain their "absence" or low abundances in other studies on the Neotropical arthropod fauna in 0-30 cm soil depth (e.g. HARADA & BANDEIRA 1994a,b; HÜTHER 1985; MACAMBIRA 1997).

#### PARTHENOGENESIS

Two pauropod species of this study had strikingly low sex ratios: *Allopauropus proximus* (2 males and 250 females; sex ratio 0.008) as well as *A. tenuis* (2 males and 211 females; sex ratio 0.009). *A. dundoensis* is only known from 200 females from the secondary upland forest under study. The two first mentioned species have often been reported from tropical and subtropical areas. Although hundreds of specimens were sexed, no males at all were found in *A. proximus* and a few ones only in *A. tenuis* (SCHELLER 1970). *A. dundoensis* has not often been collected outside Amazonia. It was previously known from about the same latitude in tropical West Africa only (REMY 1955, 1956; SCHELLER 1975) from where 29 specimens were sexed, 28 of them females and 1 male. The latter specimen was subadult and somewhat deviated from the type material. Even if it should belong to *A. dundoensis*, males seem to be extremely rare. In conclusion, males in *A. proximus* and *A. tenuis* seem to be very rare and in *A. dundoensis* they may not exist at all. As far as known *A. proximus* is parthenogenetic, *A. tenuis* probably so, at least in parts of its range, and *A. dundoensis* might be.

In two studies of north African pauropods, REMY (1947) established a striking scarcity of males in two *Allopauropus* species. In most of the European countries where he had found *Allopauropus vulgaris* (Hansen) the sex ratio was about 1.0 but in an Algerian material (99 specimens sexed adult and subadults) he could not find males at all (REMY 1947). He found a similar situation in *A. productus* Silvestri: from Europe, he reported 54 males and 70 females (sex ratio 0.77); in Algerian and Tunisian material with 155 sexed adults and subadults, there were 54 males and 101 females (sex ratio 0.53); from Morocco only 4 specimens among 73 adults and subadults were males (sex ratio 0.05) (REMY 1952). Similar sex ratios have later also been found in these species (material from Corsica: LECLERC 1953; from the Canary Islands: SCHELLER 1979) but also in other species e.g. in *A. gracilis* (Hansen) from Canada (sex ratio 0.32)

(SCHELLER 1984) as well as in *A. cuenoti* (Remy) from Switzerland (sex ratio 0.07) (SCHELLER 1976) and the Canary Islands with no males at all (SCHELLER 1979). It seems evident that populations with both males and females as well as pure female populations exist in the Pauropoda. Since in millipedes males are much rarer than females and in some species both bisexual and thelytokous forms appear (ENGHOFF 1978), probably due to the presence of bacteria (ADIS *et al.* 1999), it is plausible that the same types of reproduction have arisen in the Pauropoda too.

The sex ratio is generally low in the Pauropoda and there may be a decrease of sexual reproduction in some species (SCHELLER 1970). In many species from all parts of the world males are unknown, but in most cases the numbers of adult and subadult specimens recorded are too low to decide whether they are parthenogenetic or not. Up to now, no laboratory studies have been performed to show parthenogenesis in the Pauropoda.

Besides spanandry there is one more factor indicating the occurrence of parthenogenetic reproduction in some species. The genus *Allopaupopus* has two subgenera, the nominate subgenus with 3 pairs of setae on the pygidial sternum and 9 pairs of legs in the adult stage, and *Decapauropopus* with 2 pairs of setae on the pygidial sternum and two adult stages, one with 9 pairs of legs and an additional one with 10 pairs of legs. All the specimens of the latter stage, which have been sexed, have been females and this stage seems to be more frequent in areas with an unfavourable environment than in areas with moist and not too cold climates. It might be an adaptation to a parthenogenetic form of reproduction, occurring in areas with in some way harsh climates. Under good environmental conditions in the tropics the additional stage with 10 pairs of legs is very rare, Amazonia included.

The development of spanandry or even a thelytokous reproduction in *Allopaupopus* seems to have arisen particularly in the subgenus *Decapauropopus*. It is noteworthy, however, that in the material from the secondary upland forest near Manaus, a species in *Allopaupopus* s. str., *A. (A.) dundoensis*, seems to have such a low sex ratio that parthenogenetic reproduction might be conceivable.

#### ACKNOWLEDGEMENTS

We wish to acknowledge the valuable support received from PD Dr. W.J. Junk, Head of the Tropical Ecology Working Group at the Max-Planck-Institute (MPI) for Limnology in Plön/Germany. Dr. William Shear, Hampden-Sydney College/USA and Dr. John Lewis, Halse, Taunton/England are thanked for valuable comments on the manuscript. Berit Hansen (MPI Plön) is thanked for making the drawings. Dr. Johann Bauer, MPI for Biochemistry (Martinsried /Germany) assisted us with literature.

#### REFERENCES

- ADIS, J. 1987. Extraction of arthropods from Neotropical soils with a modified Kempson apparatus. *Journal of Tropical Ecology* 3 (2): 131-138.
- ADIS, J. 1992. Überlebensstrategien terrestrischer Invertebraten in Überschwemmungswäldern Zentralamazoniens. *Verhandlungen des Naturwissenschaftlichen Vereins in Hamburg (NF)* 33: 21-114.

- ADIS, J. 1997. Terrestrial invertebrates: Survival strategies, group spectrum, dominance and activity patterns. *In*: JUNK, W.J. (ed.). The Central Amazon floodplain. Ecology of a pulsing system: 299-317. *Ecological Studies* 126. Springer, Heidelberg, 525 pp.
- ADIS, J. & LATIF, M. 1996. Amazonian arthropods react to El Niño. *Biotropica* 28 (3): 403-408.
- ADIS, J. & SCHUBART, H.O.R. 1984. Ecological research on arthropods in Central Amazonian forest ecosystems with recommendations for study procedures. *In*: COOLEY, J.H. & F.B. GOLLEY (eds). Trends in ecological research for the 1980s: 111-144. *NATO Conference Series, Series I: Ecology, Vol. 7. Plenum Press, New York, London*, 344 pp.
- ADIS, J., MORAIS, J.W. DE & MESQUITA, H.G. DE 1987a. Vertical distribution and abundance of arthropods in the soil of a Neotropical secondary forest during the rainy season. *Studies on Neotropical Fauna & Environment* 22 (4): 189-197.
- ADIS, J., MORAIS, J.W. DE & RIBEIRO, E.F. 1987b. Vertical distribution and abundance of arthropods in the soil of a Neotropical secondary forest during the dry season. *Tropical Ecology* 28 (1): 174-181.
- ADIS, J., GOLOVATCH, S.I., WILCK, L. & HANSEN, B. 1999. On the identities of *Muyudesmus obliteratus* Kraus, 1960 versus *Poratia digitata* (Porat, 1889), with first biological observations on parthenogenetic and bisexual populations (Diplopoda: Polydesmida: Pyrgodesmidae). *Fragmenta Faunistica*: in press.
- ADIS, J., MORAIS, J.W. DE, RIBEIRO, E.F. & RIBEIRO, J.C. 1989a. Vertical distribution and abundance of arthropods from white sand soil of a Neotropical campinarana forest during the rainy season. *Studies on Neotropical Fauna & Environment* 24 (4): 193-200.
- ADIS, J., PAARMANN, W., FONSECA, C.R. & RAFAEL, J.A. 1997c. Knock - down efficiency of natural pyrethrum and survival rate of arthropods obtained by canopy fogging in Central Amazonia. *In*: STORK, N.E., ADIS, J. & DIDHAM, R.K. (eds). Canopy arthropods: 67-81. *Chapman & Hall, London*, 576 pp.
- ADIS, J., RIBEIRO, E.F., MORAIS, J.W. DE & CAVALCANTE, E.T.S. 1989b. Vertical distribution and abundance of arthropods from white sand soil of a Neotropical campinarana forest during the dry season. *Studies on Neotropical Fauna & Environment* 24 (4): 201-211.
- ADIS, J., SCHELLER, U., MORAIS, J.W. DE, ROCHUS, C. & RODRIGUES, J.M.G. 1997b. Symphyla (Myriapoda) from Amazonian non-flooded upland forests and their adaptations to inundation forests. *In*: ENGHOFF, H. (ed.). Many-legged animals. A collection of papers on Myriapoda and Onychophora. *Entomologica Scandinavica Supplement* 51: 115-119.
- ADIS, J., SCHELLER, U., MORAIS, J.W. DE & RODRIGUES, J.M.G. 1997a. On the abundance and phenology of Palpigradi (Arachnida) from Central Amazonian upland forests. *The Journal of Arachnology* 25: 326-332.
- ADIS, J., MINELLI, A., MORAIS, J.W. DE, PEREIRA, L.A., BARBIERI, F. & RODRIGUES, J.M.G. 1996. On abundance and phenology of Geophilomorpha (Chilopoda) from Central Amazonian upland forests. *Ecotropica* 2: 165-175.
- CAVALLI-SFORZA, L. 1972. Grundzüge biologisch-medizinischer Statistik. *G. Fischer, Stuttgart*, 212 pp.
- ENGHOFF, H. 1978. Parthenogenesis and spanandry in millipedes. *Abhandlungen und Verhandlungen des Naturwissenschaftlichen Vereins in Hamburg (NF)* 21/22: 73-85.
- FRANKLIN, E., ADIS, J. & WOAS, S. 1997. The oribatid mites. *In*: JUNK, W.J. (ed.). The Central Amazon floodplain. Ecology of a pulsing system: 331-349. *Ecological Studies* 126. Springer, Heidelberg, 525 pp.
- HARADA, A.Y. & BANDEIRA, A.G. 1994a. Estratificação e densidade de invertebrados em solo arenoso sob floresta e plantios arbóreos na Amazônia central durante a estação seca. *Acta Amazonica* 24 (1/2): 103-118.
- HARADA, A.Y. & BANDEIRA, A.G. 1994b. Estratificação e densidade de invertebrados em solo argiloso sob floresta e plantios arbóreos na Amazônia central durante a estação seca. *Boletim do Museu Paraense Emílio Goeldi, série Zoologia* 10 (2): 235-251.

- HÜTHER, W. 1985. Verbreitung und Vorkommen einiger Pauropodenarten im brasilianischen Amazonas-Gebiet. *Bijdragen tot de Dierkunde* 55 (1): 95-99.
- JORDAN, C.F. 1984. Soils of the Amazon rainforest. In: PRANCE, G.T. & LOVEJOY, T.E. (eds). *Amazonia*: 83-105. Pergamon Press, Oxford, 442 pp.
- LECLERC, M. 1953. Pauropodes de Corse. *Bulletin du Muséum national d'Histoire naturelle (Paris)* (2) 25: 395-399.
- MACAMBIRA, M.L.J. 1997. A fauna de invertebrados do solo. In: LISBOA, P.L.B. (ed.), *Caxiuana: 366-360. Museu Paraense Emílio Goeldi*. Belém, Brazil. 446 pp.
- PENNY, N.D. & ARIAS, J. 1982. Insects of an Amazon forest. *Columbia University Press, New York*. 269 pp.
- REMY, P.A. 1947. Liste de Pauropodes d'Algérie, avec description de formes nouvelles. *Bulletin de la Société des sciences de Nancy, (n.S.)* 6: 66-84.
- REMY, P.A. 1952. Contribution à la faune endogée du Maroc. Pauropodes. *Bulletin de la Société des Sciences Naturelles et Physiques du Maroc* 31: 41-51.
- REMY, P.A. 1955. Pauropodes de l'Angola. *Publicações culturais. Companhia de Diamantes de Angola* 24: 117-1354.
- REMY, P.A. 1956. Contribution à la microfaune endogée de l'Afrique tropicale: Palpigrades et Pauropodes. *Revue de Zoologie et de Botanique africaines* 53: 327-335.
- RIBEIRO, M.O. DE A. 1994. Abundância, distribuição vertical e biomassa de artrópodos do solo em uma capoeira na Amazônia Central. *M.Sc. Thesis, INPA/UFAM*, Brazil, 106 pp.
- RIBEIRO, M. DE N.G. & ADIS, J. 1984. Local rainfall variability - a potential bias for bioecological studies in the Central Amazon. *Acta Amazonica* 14 (1/2): 159-174.
- RODRIGUES, J.M.G. 1986. Abundância e distribuição vertical de Arthropoda do solo, em capoeira de terra firme. *M.Sc. Thesis, CNPq/INPA/FUA*, Manaus, Brazil, 80 pp.
- SHELLER, U. 1970. The Pauropoda of Ceylon. *Entomologica scandinavica, Supplement* 1: 5-97.
- SHELLER, U. 1974. Pauropoda from arable soil in Great Britain. In: BLOWER, J.G. (ed.). *Myriapoda. Symposia of The Zoological Society of London* 32: 405-410.
- SHELLER, U. 1975. Contribution to the knowledge of the Angolan Pauropoda (Myriapoda). *Publicações culturais. Companhia de Diamantes de Angola* 89: 61-102.
- SHELLER, U. 1976. A review of the Swiss Pauropoda (Myriapoda). The pauropoda and Symphyla of the Geneva Museum II. *Revue suisse de Zoologie* 83: 3-37.
- SHELLER, U. 1979. Pauropodidae (Myriapoda, Pauropoda) from the Canary Islands. *Entomologica scandinavica* 10: 177-186.
- SHELLER, U. 1984. Pauropoda (Myriapoda) from Canada. *Canadian Journal of Zoology* 62: 2074-2091.
- SHELLER, U. 1994. Pauropoda of a secondary forest near the Tarumã Mirim River, Amazonas, Brazil (Myriapoda, Pauropoda, Pauropodidae). *Amazoniana* 13 (1/2): 65-130.
- SHELLER, U. 1997. Pauropoda from upland and inundation forests in Central Amazonia, Brazil (Myriapoda, Pauropoda: Millotauropodidae, Pauropodidae). *Amazoniana* 14 (3/4): 223-300.
- SÊRAFINO, A. & MERINO, J.F. 1978. Poblaciones de microartrópodos en diferentes suelos de Costa Rica. *Revista de Biología Tropical* 26 (1): 139-151.

## Freshwater sponges (Porifera, Spongillidae) from the Lake of Geneva, Switzerland

Renata MANCONI<sup>1</sup> & Ruth DESQUEYROUX-FAÚNDEZ<sup>2</sup>

<sup>1</sup>Dipartimento di Zoologia e Antropologia Biologica dell'Università,  
Via Muroni 25, I-07100 Sassari, Italy.

<sup>2</sup>Muséum d'histoire naturelle, Case postale 6434, CH-1211 Geneva 6, Switzerland.

**Freshwater sponges (Porifera, Spongillidae) from the Lake of Geneva, Switzerland.** - A census of the sponge fauna in shallow-waters of the Lake of Geneva, Switzerland, displayed the presence of scattered populations of *Spongilla lacustris* (Linnaeus, 1758), *Eunapius fragilis* (Leidy, 1851), *Ephydatia fluviatilis* (Linnaeus, 1758), and *Ephydatia muelleri* (Lieberkühn, 1855). *Spongilla lacustris* was the most frequent species, either alone or associated with other species it was present in numerous sites on a variety of substrata along the entire shoreline. The morphological analysis of specimens of *S. lacustris* of the Lake of Geneva compared with the type material of *S. lacustris* and *Spongilla helvetica*, shows a considerable variation of skeletal and gemmular characters. Therefore, the synonymy of *S. helvetica* with *S. lacustris* is confirmed. The study also demonstrates the existence of a rich and diversified sponge fauna in the Lake of Geneva.

**Key-words:** *Spongilla lacustris* - *Spongilla helvetica* - Lake of Geneva (Lac Léman) - freshwater sponges - distribution - morphology - biodiversity.

### INTRODUCTION

Five species of spongillids are actually known from Switzerland (see map): *Spongilla lacustris* (Linnaeus, 1758), *Eunapius fragilis* (Leidy, 1851), *Ephydatia fluviatilis* (Linnaeus, 1758), *Ephydatia muelleri* (Lieberkühn, 1855) and *Trochospongilla horrida* Weltner, 1893. Only four of them are presently known to occur in the Lake of Geneva. *Trochospongilla horrida* has only been reported for the Lake of Neuchâtel. ANNANDALE (1909) described *Spongilla helvetica*, from the Lake of Geneva with no other records from other localities. This species was considered doubtful by some authors (cf. ARNDT 1926; GEE 1931, 1932). JØRGENSEN (1946), referring only to the description of thin-walled gemmule, considered *S. helvetica* conspecific with *S. lacustris*. PENNEY & RACEK (1968) suggested a close affinity between *Spongilla helvetica* and *Spongilla lacustris*, but in view of the paucity of the material examined by them, they considered advisable to retain *Spongilla helvetica* as an available species. After the study of a paratype of the species, EZCURRA DE DRAGO (1972), considered *Spongilla helvetica* conspecific with *Spongilla lacustris*.

In this work, we studied type material and different populations of *Spongilla lacustris*, paying particular attention to the morphology of the gemmules, by making a SEM analysis of the gemmule structure of the neotype of *S. lacustris* (Figs 5-10) and of the paratype of *S. helvetica* (Figs 11-16). At the same time, the spicular morphology and micrometry of specimens formerly identified as *Spongilla lacustris* and *Spongilla helvetica* from different localities in Switzerland, were analysed (Table 1). In addition, we include here the results of a species census for the Spongillidae represented at different localities of the Lakes of Geneva and Neuchâtel (see map).

## MATERIALS AND METHODS

### ABBREVIATIONS

IZUG = Istituto di Zoologia dell'Università di Genova;

LEBA = Laboratoire d'Ecologie et de Biologie Aquatique, Université de Genève;

MHNG<sup>1</sup> = Muséum d'histoire naturelle, Genève;

NNHML = (Rijksmuseum van Natuurlijke Historie, Leiden), National Natur Historisch Museum, Leiden;

SEM = Scanning Electro-Microscopy;

US = Università di Sassari;

MURST<sup>1</sup> = Ministero italiano dell'Università e della Ricerca Scientifica e Tecnologica;

INTERREG-UE<sup>1</sup> = European interregional (Sardinia-Corsica) project, European Community.

### COLLECTIONS

Freshwater sponges were collected by C. Vaucher (MHNG) in 1977 and 1993 in the Lake of Neuchâtel and by B. Lods-Crozet and D. Cambin (LEBA) from 1989 to 1993, in the Lake of Geneva. Samples were obtained either by hand or by scuba diving at 31 sites along the lake borders (LODS-CROZET 1999: in the press). All specimens were identified to species level and registered for the MHNG collections. A morphological and micrometrical study of spicules and gemmules was made with *Spongilla lacustris* type material and with the collected samples of the Lakes of Geneva, Neuchâtel and River Rhône.

Measurements of mega-, micro- and gemmulo-scleres (in  $\mu\text{m}$ ), were obtained with an compound microscope connected to a camera lucida and a Graphtec Digitizer KD 4300 (Table 1). A minimum of 20 spicules were measured.

The following additional material was studied for comparison: *Spongilla helvetica* Annandale, 1909, holotype and paratype, reg. n° MHNG-18970 INVE and MHNG-18980 INVE, Morges, Lake of Geneva, Switzerland, Collection Ostroga, respectively, 10.1900 and 07.1902; *Spongilla lacustris*, neotype designation by PENNEY & RACEK (1968), reg. n° 1053, NNHML, Vlaardingschwaart, the Netherlands, coll. D. v. d. Kuyl, 09. 1941; *Spongilla lacustris*, det. Ezcurra de Drago, reg. n° FW 22 IZUG and FW 123

<sup>1</sup>First author's research was supported by grants of MHNG, MURS, INTERREG-UE.

IZUG, Bolle de Magadino, Switzerland. Sizes of mega-, micro- and gemmulo-scleres (in  $\mu\text{m}$ ), and presence of gemmular cages and foramina were investigated (Table 2).

Spicule slides (prepared as indicated by PRONZATO & MANCONI 1989) and the SEM study were made at the MHNG. A Zeiss Digital Scan Microscope DSM 940 was used, after sputtering the samples with gold-palladium.

## RESULTS

### HABITAT AND DISTRIBUTION

Several populations (see map) of *Spongilla lacustris*, *Eunapius fragilis*, *Ephydatia fluviatilis*, and *E. muelleri* are present in the Lake of Geneva; *Trochospongilla horrida* was collected only at one locality of the Lake of Neuchâtel. *Ephydatia fluviatilis*, and *E. muelleri* were rare along the northern side of the Lake Neuchâtel (two of seven localities studied), but present on both sides of the Lake of Geneva. *Eunapius fragilis*, was present in five of nine localities of the Lake of Geneva. *Spongilla lacustris* the most common species, was widespread along the entire shoreline of the lakes of Geneva and Neuchâtel (48% of 39 sampled sites), it was very common at depths ranging from 0.2 to 3.5 m, either alone (73%) or associated with *Eunapius fragilis* (20%) or *E. fluviatilis* (13%). *Spongilla lacustris* was present, on a variety of substrata, e.g. wood piles or floating wood (34%), pebbles and boulders (20%), rocks and cliffs (18%), metallic piles (10%), brick walls and piles (8%), shells (8%) and concrete piles (2%). All the represented species are seasonal and active specimens and were found only from spring to autumn.

### DESCRIPTION

*Spongilla lacustris* is encrusting to massive or cushion-shape to branching. Consistence, fragile, soft. Dimensions, 2 to 70 cm. Colour, white to yellow-orange or light green; light brown or brown after fixation. Surface uneven, hispid, with irregularly scattered small oscula, covered by a fine, fragile ectosomal membrane.

Skeleton: Ectosome, short brushes of spicules, perpendicular to the surface, issued from the ends of primary longitudinal fibres. Choanosome, anisotropic network of pauci- to multi-spicular longitudinal primary fibres with a strong sheath of spongin, connected by transversal secondary pauci-spicular fibres. Skeletal meshes irregular in size and form.

Spicules (Table 1, Figs 1-4) Megascleres oxeads, bent, fusiform with acerate or blunt, rarely hastate or conical, apices, 90-308  $\mu\text{m}$  length by 2-8  $\mu\text{m}$  in diameter. Some of them are slightly spined and associated to gemmules. Microscleres microxeas, bent, fusiform, strongly microspined, 25-178  $\mu\text{m}$  length by 2-8  $\mu\text{m}$  in diameter; they may be abundant or rare.

Gemmules: 98-789  $\mu\text{m}$  in diameter, present in active sponges from March to November, in dense clusters or irregularly scattered within the skeletal framework. Gemmular shape ranged from spherical to oval and sometimes a spicular cage composed by megascleres is present. Two gemmular types were observed: either armed (with gemmuloscleres) or naked (without gemmuloscleres). Both types sometimes can



Spongillidae species presently collected at different localities in Switzerland, Lakes of Geneva and Neuchâtel. 1 = *Spongilla lacustris*; 2 = *Eumapius fragilis*; 3 = *Ephydatia fluviatilis*; 4 = *E. muelleri*; 5 = *Trochospongilla horrida*.

FIGS 1-4. *Spongilla lacustris* (L., 1759), neotype, NNML 1053, Vlaardingschaart, the Netherlands and *Spongilla helvetica* Annandale, 1909, holotype, MHNG 18970 INVE, paratype, MHNG 18980 INVE, Morges, 1909. Fig. 1. Megascleres: smooth to slightly spined oxeas and its apical morphology. Figs 1a, c, g: *S. helvetica*, paratype; figs 1b, d, e, f, h, i, j, k: *S. lacustris*, neotype. Fig. 2. Microscleres: bent oxeas strongly microspined. Figs 2a, b. *S. helvetica*, paratype; figs 2c, d. *S. lacustris*, neotype. Fig. 3. Gemmuloscleres, variably bent oxeas, strongly microspined. Figs 3b, c. *S. helvetica*, holotype; figs 3a, d. *S. lacustris*, neotype. Fig. 4. *S. helvetica*, paratype, cage of spicules on the surface of a gemmule. Scales: Figs 1a - c, 1f, g, 2c, 4 = 100  $\mu$ m; Figs 1d, e, h - k, 2a, b, d, 3a - d = 10  $\mu$ m.



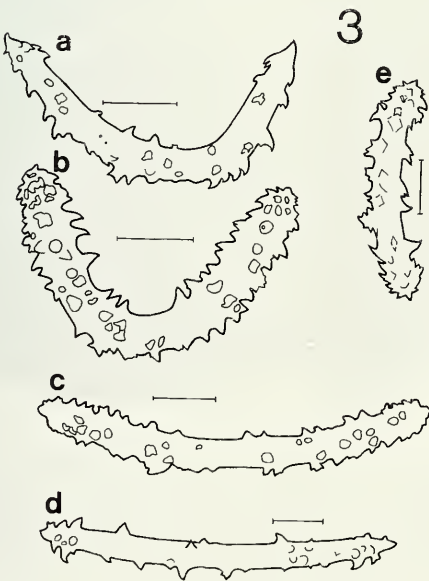
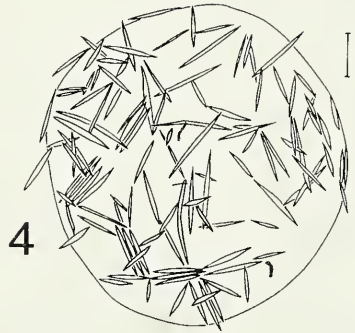
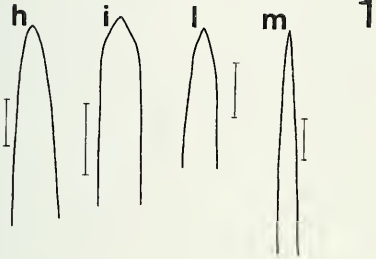
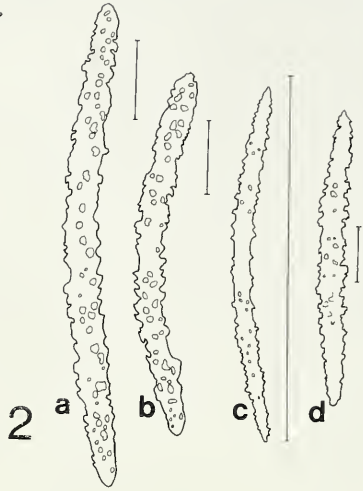
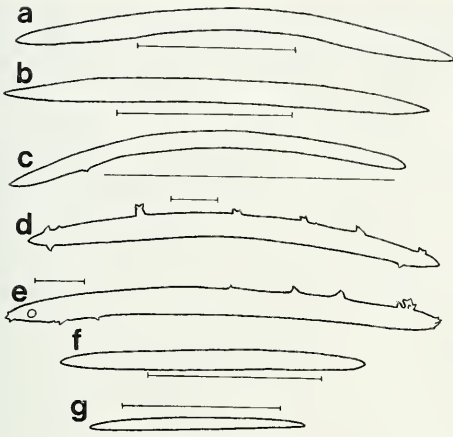

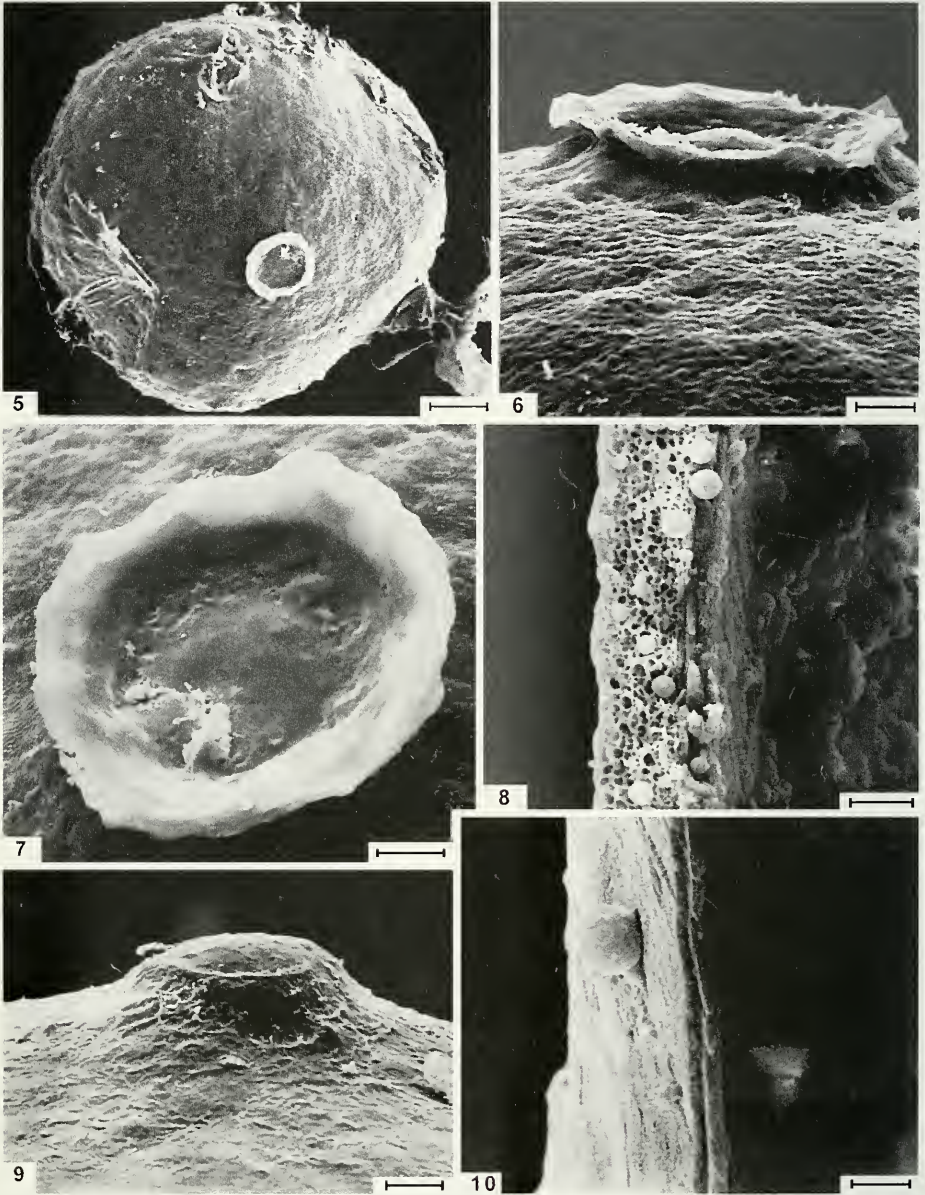

FIGS 5-10. *Spongilla lacustris* (L., 1759) neotype NNML 1053. Vlaardingschwaart, the Netherlands. Fig. 5. thick-walled gemmule, foramen with collar. Fig. 6. lateral view of the same type of foramen. Fig. 7. plate-like, enlarged frontal view of the of the same type of foramen. Fig. 8. transversal section of the theca in a thick-walled gemmule. Fig. 9. foramen without collar of a thin-walled gemmule. Fig. 10. transversal section of the theca in a thin-walled gemmule. Scales: Fig. 5 = 100  $\mu\text{m}$ . Figs 6, 7, 9 = 20  $\mu\text{m}$ ., Fig. 8 = 10  $\mu\text{m}$ ; Fig. 10 = 2  $\mu\text{m}$ .

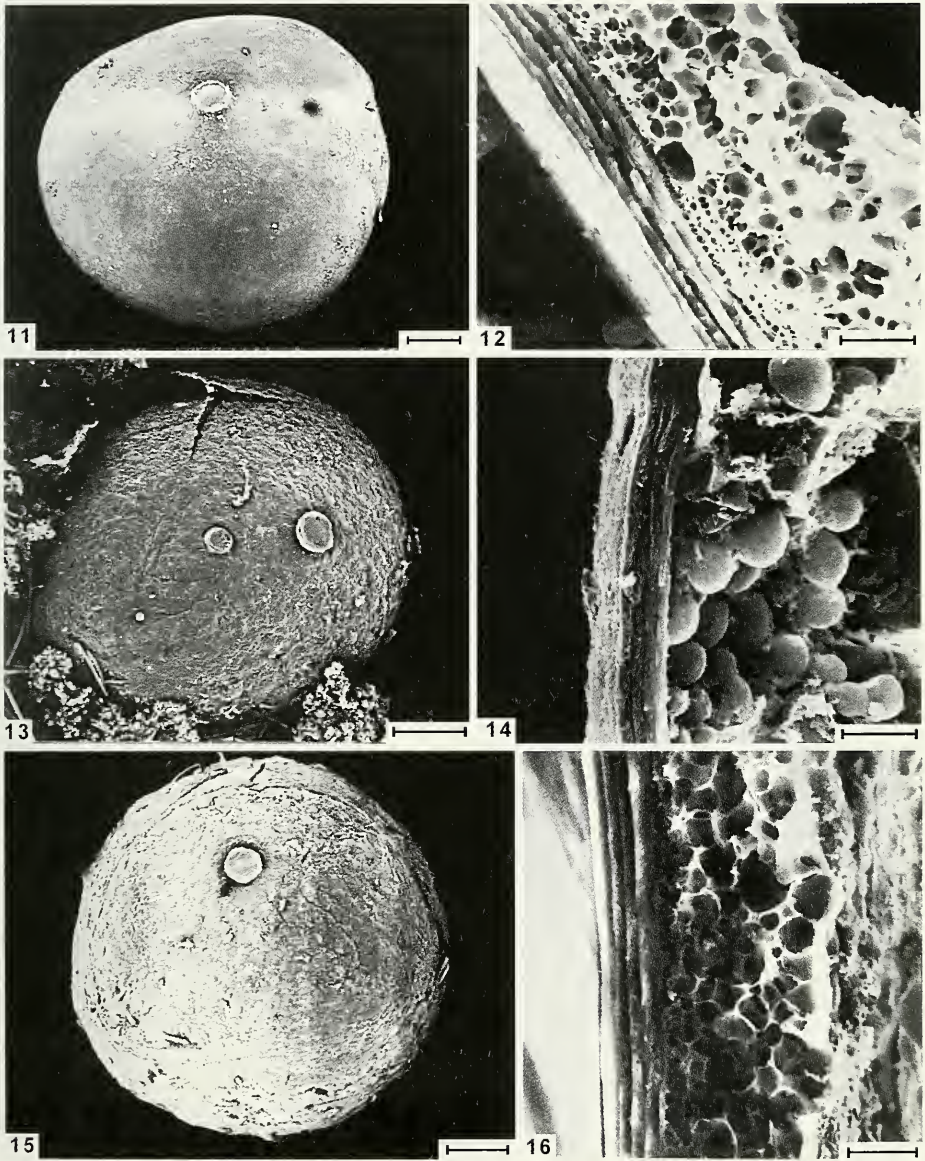

FIGS 11-16. *Spongilla helvetica* Annandale, 1909, paratype. Fig. 11, Gemmule (thick-walled) with a single foramen. Fig. 12, thick gemmular theca with well developed pneumatic layer and inner coat with 5 sub-layers. Fig. 13, gemmule (thin-walled) with two foramina. Fig. 14, thin gemmular theca pneumatic layer and inner coat with 4 sub-layers. Fig. 15, gemmule with two foramina, lateral view of the second foramen, left on top. Fig. 16, gemmular theca of a gemmule with two foramina; well developed pneumatic layer and inner coat with 5 sub-layers. Scales: Figs 11, 13, 15 = 100  $\mu$ m. Figs 12, 14, 16 = 5  $\mu$ m.

TABLE 1

Mega, micro and gemmuloscleres; gemmule micrometries of *Spongilla lacustris* (Linnaeus, 1759) specimens presently collected from different localities of Switzerland. Micrometries refer to minimum, mean and maximum range of spicular length and diameter, and gemmular diameter, in  $\mu\text{m}$ .

Locality	Megascleres	Microscleres	Gemmuloscleres	Gemmules
River Rhône	163- <u>227</u> -290 3.0- <u>4.8</u> -6.7	49- <u>69</u> -90 1- <u>2.1</u> -4	44- <u>54</u> -64 2- <u>2.4</u> -4	373- <u>469</u> -565
Lake of Geneva	155- <u>187</u> -218 2.5- <u>4.0</u> -5.5	43- <u>62</u> -81 1- <u>1.7</u> -8	41- <u>63</u> -84 1- <u>2.1</u> -4	362- <u>473</u> -584
Lake of Neuchâtel	198- <u>207</u> -216 6.2- <u>6.7</u> -7.2	32- <u>46</u> -59 2- <u>2.6</u> -4	57- <u>70</u> -82 2- <u>2.4</u> -3.4	428- <u>502</u> -575

TABLE 2

Mega, micro and gemmuloscleres; gemmule micrometries; presence or not of cage and foramina number in: *Spongilla lacustris* (Linnaeus, 1758): neotype NNML 1053, Vlaardingschwaart, Netherland; *S. lacustris* in literature; *S. lacustris*, FW 22 IZUG, FW 123 IZUG, Bolle de Magadino, coll. Ezcurra de Drago; *S. lacustris* (= *Spongilla helvetica* Annandale, 1909), holotype, MHNG 18970 INVE, paratype, MHNG 18980 INVE, Morges, 1909. (\*) From literature or (\*\*\*) presently remeasured. Micrometries refer to minimum mean and maximum range of spicular length and diameter, and gemmular diameter, in  $\mu\text{m}$ . N = spicular number, stated in each case.

Species name	Mega-scleres	Micro-scleres	Gemmulo-scleres	Gemmules	Cage	Foramina
<i>Spongilla lacustris</i>						
**Neotype 1053 NNML	122-273 x 5-16 n = 270	47-102 x 3-7 n = 50	35-127 x 3-7 n = 100	383-636 n = 22	+	1
*Penney & Racek, 1968	200-350 x 6 - 18	70-130 x 2 - 8	80-130 x 3 - 10	500-800	?	?
**FW 22 IZUG Bolle de Magadino	160-247 x 6-16 n = 22	not measured	44-77 x 4-7 n = 20	A	—	1
**FW 123 IZUG Bolle de Magadino	160-247 x 6-16 n = 22	not measured	30-77 x 3-6 n = 22	A	—	1 or +
*Bolle de Magadino Ezcurra de Drago, 1972	150-350 x 8-30	50-90 x 3-8	30-150 x 5-10	A	—	—
* <i>S. helvetica</i> Annandale, 1909	not measured	not measured	not measured	not measured	A	1 or +
**Holotype MHNG 18970 INVE Morges	147- <u>241</u> -317 x 5- <u>10</u> -18 n = 250	28-49 x 1-2 n = 12	51-77 x 2-3 n = 4	578-801 n = 11	+	1 or +
**Paratype MHNG 18980 INVE Morges	115-294 x 4-14 n = 250	44-68 x 3-5 n = 20	35-99 x 3-7 n = 30	495-810 n = 18	+	1 or +

be found in the same specimen. The coat of gemmules ranges from thick-walled with three layers (outer, pneumatic, inner layer) to thin-walled if the coat is composed only of compact spongin in a variable number (3-7) of sub-layers, in total corresponding to the inner layer of the thick walled gemmulae. A distinct horny external layer is present in some gemmules with a thick-walled theca. Thick-walled gemmules bear generally a single foramen and an irregular outer surface due to the presence of gemmuloscleres. Some gemmules with several foramina and a well developed pneumatic layer were observed. Thin-walled gemmules show generally a smooth surface and 1-6 foramina. Slightly elevated foramina without, or with a normal or plate-like collar, are irregularly present.

Gemmuloscleres: oxeas to strongyles, straight or variably curved up to a ring-shape and densely microspined, with blunt and sometimes less microspined apices. Abundant, rare or absent, according to the gemmular type concerned, 21 - 130  $\mu\text{m}$ , in length by 1-4  $\mu\text{m}$  in diameter. Gemmuloscleres are external to or variably embedded in the gemmular theca.

## DISCUSSION

The study of *S. lacustris* from the Lake of Geneva illustrates the great variability of the taxonomic important characters, both, within the same individual or between individuals (MANCONI & PRONZATO 1991; RICCIARDI & REISWIG 1993). Concerning the spicular and gemmular characters, we observed that thick and thin-walled thecae in gemmules can occur in the same specimen, but some specimen have one gemmular type only. The presence may, depend on the season and hence on the life cycle phase. The cage of megascleres around thin-walled gemmules is a very variable trait. We regularly observed a cage in *S. lacustris*, but it was rarely recorded by other authors (RETZER 1883; VEJDOVSKY 1887; ANNANDALE 1909; JORGENSEN 1946).

The comparative analysis of shape and size of *S. lacustris* recently collected from the Lake of Geneva, the neotype of *S. lacustris* and the type material of *S. helvetica*, revealed that both diagnostic characters at the spicular level (Figs 1-4), and gemmular morphology (Figs 5-16) fall within the range of *S. lacustris* Auct. This confirmed the morphological variability of *Spongilla lacustris* (POTTS 1887; VEJDOVSKY 1887; PENNEY & RACEK 1968; GILBERT & SIMPSON 1976). The morphological analysis by SEM of gemmules (Figs 5-10, 11-16) of *S. helvetica* type material and *S. lacustris* neotype, shows that the former species is indistinguishable from the later. The study of intraindividual variability (Table 1) confirms here the extremely high phenotypic plasticity of gemmular morphology. The same remark is valid for several varieties and 'morphospecies' similar to *S. lacustris*, that were described from Europe and North America based on gemmular traits (POTTS 1887; VEJDOVSKY 1887; PENNEY & RACEK 1968; EZCURRA DE DRAGO 1972).

In addition, our study confirms that the extreme variability of the gemmular structure in *S. lacustris* can be attributed to both the position of gemmules within the sponge body and to their life cycle phases as suggested by other authors (JORGENSEN 1946; GILBERT & SIMPSON 1976).

## ACKNOWLEDGEMENTS

The following persons have greatly contributed to our work and we are grateful: G. Haartog, NNHML; Tiziana Cubeddu, USC; Peter Schuchert, Jean Wüest, Claude Rotton and G. Roth, MHNG. Important collections in the Lake of Geneva, made by B. Lods-Crozet and D. Cambin (LEBA), were at the origin of this work.

## REFERENCES

- ANNANDALE, N. 1909. Description d'une nouvelle espèce d'éponge d'eau douce du Lac de Genève. *Revue suisse de Zoologie* 17: 367-369, pl. 9.
- ARNDT, W. 1926. Die Spongillidenfauna Europas. *Archiv für Hydrobiologie* 17: 337-365.
- EZCURRA DE DRAGO, I. 1972. Contributo alla conoscenza delle spugne d'acqua dolce d'Italia (Porifera, Spongillidae). *Memorie dell'Istituto Italiano di Idrobiologia Marco de Marchi* 29: 109-127.
- GEE, N.G. 1931. A contribution towards an alphabetical list of the known fresh-water sponges. *Peking Natural History Bulletin* 5: 31-52.
- GEE, N.G. 1932. The known fresh-water sponges. *Peking Natural History Bulletin* 6: 25-51.
- GILBERT, J.J. & SIMPSON, T.L. 1976. Gemmule Polymorphism in the Freshwater Sponge *Spongilla lacustris*. *Archiv für Hydrobiologie* 78(2): 268-277.
- JØRGENSEN, C.B. 1946. On the gemmules of *Spongilla lacustris* Auct. together with some remarks on the taxonomy of the species. *Videnskabelige Meddelelser fra Dansk naturhistorisk Forening i Kjøbenhavn* 109: 69-79.
- LODS-CROZET, B. 1999. (In the press). Invertébrés benthiques de la zone littorale du Léman. Evolution depuis le début du siècle. 13 pp. In: Musée du Léman & Slatkine (eds), Genève. *Actes du colloque 100 ans après Forel*.
- MANCONI, R. & PRONZATO, R. 1991. Life cycle of *Spongilla lacustris* (Porifera, Spongillidae): a cue for environment-dependent phenotype. *Hydrobiologia* 220: 155-160.
- PENNEY, J.T. & RACEK, A.A. 1968. Comprehensive Revision of a Worldwide Collection of Freshwater Sponges (Porifera: Spongillidae). *United States National Museum Bulletin* 272: 1-184.
- POTTS, E. 1887. Contributions towards a synopsis of the American forms of fresh-water sponges with descriptions of those named by other authors and from all parts of the world. *Proceedings of the Academy of Natural Sciences Philadelphia*: 158-279, pls 5-12.
- PRONZATO, R. & MANCONI, R. 1989. Chiave dicotomica per il riconoscimento delle spugne d'acqua dolce italiane. *Bollettino del Museo e Istituti Biologici dell'Università di Genova* 53: 81-99.
- RETZER, W. 1883. Die deutschen Süßwasserschwämme. *Inaugural Dissertation, Universität Tübingen*, 1-30.
- RICCIARDI A. & REISWIG, H.M. 1993. Freshwater sponges (Porifera, Spongillidae) of eastern Canada: taxonomy, distribution, and ecology. *Canadian Journal of Zoology* 71: 665-682.
- SCELLENBERG, U. & BURLA, H. 1972. Schwämme (Porifera) im Zürichsee. *Revue suisse de Zoologie* 79 (suppl.): 319-332.
- VEJDovsky, F. 1887. Diagnosis of the European Spongillidae, pp. 172-180. In: POTTS, E. (ed.). Contributions towards a synopsis of the American forms of freshwater Sponges with descriptions of those named by other authors and from all parts of the world. *Proceedings of the Academy of Natural Sciences of Philadelphia*.

## Endoparasitic helminths of fishes in three Alpine lakes in France and Switzerland

Vladimíra HANZELOVÁ<sup>1</sup>, Tomáš SCHOLZ<sup>2</sup>, Daniel GERDEAUX<sup>3</sup>  
& Alain de CHAMBRIER<sup>4</sup>

<sup>1</sup> Parasitological Institute, Slovak Academy of Sciences, Hlinkova 3, 040 01 Košice, Slovak Republic.

<sup>2</sup> Institute of Parasitology, Academy of Sciences of the Czech Republic, Branišovská 31, 370 05 České Budějovice, Czech Republic.

<sup>3</sup> Institute of Hydrobiology, INRA, BP 511, F-74 203 Thonon-les-Bains, France.

<sup>4</sup> Natural History Museum, P.O. Box 6434, CH-1211 Geneva 6, Switzerland.

**Endoparasitic helminths of fishes in three Alpine lakes in France and Switzerland.** – A systematic survey of endoparasitic helminths of 9 species of fishes from three Alpine lakes, Annecy, Bourget (both France) and Geneva Lake (Switzerland and France), is presented. Eleven species of intestinal helminths (2 Digenea, 7 Cestoda, 1 Nematoda and 1 Acanthocephala) were found in 272 of 372 (i.e. 73%) fish species examined. The dominant parasites were pseudophyllidean tapeworms *Eubothrium crassum* (Bloch, 1779) and *E. salvelini* (Schrank, 1790) in lake trout (*Salmo trutta m. lacustris*) and Arctic char (*Salvelinus alpinus*) respectively, and the proteocephalidean *Proteocephalus longicollis* (Zeder, 1800) in whitefish (*Coregonus lavaretus*).

**Key-words:** Endohelminths – fishes – Alpine lakes – France – Switzerland.

### INTRODUCTION

Little attention has been paid to studies on the parasite fauna of Alpine lakes despite their importance for fishery and sport fishing (GERDEAUX *et al.* 1995). This is also valid for three large lakes in the western part of the Alps, namely Annecy and Bourget lakes in France and Geneva Lake situated between Switzerland and France.

Up to now, only a few data on the helminths parasitizing fishes in these lakes have been published, with most records related to Geneva Lake. ZSCHOKKE (1884) reported several taxa of *Ichthyotaenia* (= *Proteocephalus*) from fishes in Geneva Lake but most are now considered invalid (see SCHOLZ & HANZELOVÁ 1998). JOYEUX & BAER (1936) listed several helminth species from this lake, including tapeworms *Cyathocephalus truncatus*, *Eubothrium crassum*, *E. salvelini*, *Triaenophorus crassus*, *Proteocephalus dubius* (= *P. percae*), *P. longicollis*, *P. fallax*, *P. neglectus*, *P. salmonisumblae* (three latter species synonymized with *P. longicollis* – SCHOLZ & HANZELOVÁ

1998), and *P. torulosus*. DOBY & JARECKA (1964), JARECKA & DOBY (1965), and MORANDI & PONTON (1989) studied the biology of *Proteocephalus* tapeworms (most probably *P. longicollis*) in whitefish (*Coregonus lavaretus*) from Geneva Lake and in experimentally infected copepods.

However, except for a study by GERDEAUX *et al.* (1995), who reported the occurrence of the pseudophyllidean cestode *Eubotrium salvelini* in Arctic char (*Salvelinus alpinus*), almost no information exists about species composition and richness of the helminth fauna of fishes in Annecy and Bourget lakes.

During studies on the ecology of fishes in Annecy and Bourget lakes, heavy infections of salmonids, in particular of Arctic char with *E. salvelini*, were recorded since December 1992 (D. Gerdeaux – unpublished data; GERDEAUX *et al.* 1995). In order to provide more detailed information about helminth parasites, samples of fishes from the above mentioned lakes and Geneva Lake were taken between 1992 and 1998. In this paper, a survey of endoparasitic helminths found is presented.

## MATERIALS AND METHODS

Samples were taken from three peri-alpine lakes in the western part of the Alps, namely Annecy Lake (Lac d'Annecy), Bourget Lake (Lac du Bourget; both Haute Savoie, France) and Geneva Lake (Lac Léman; Switzerland and France).

All lakes are of glacial origin and they have steep banks and a relatively flat bottom. Annecy Lake is an oligotrophic lake with a surface of 2,800 hectares and maximum depth 65 metres. It is highly productive in fish, with highest natural production of coregone (whitefish) and stocking production of Arctic char. Bourget Lake is an eutrophic lake with a surface of 4,500 hectares and maximum depth 145 m. It is rich mainly in perch (*Perca fluviatilis*), lake trout (*Salmo trutta m. lacustris*) and cyprinid fishes; sustained by stocking yields of whitefish and Arctic char are rather low. Geneva Lake is a mesotrophic lake situated between Switzerland and France; it has a

TABLE 1  
Number of fish examined

Species	Annecy	Bourget	Geneva	Total
<i>Esox lucius</i>	2	4		6
<i>Salmo trutta m. lacustris</i>	8	4	4	16
<i>Salvelinus alpinus</i>	34	16	12	62
<i>Coregonus lavaretus</i>	40	14	21	75
<i>Lota lota</i>	18		4	22
<i>Alburnus alburnus</i>			1	1
<i>Rutilus rutilus</i>	10		40	50
<i>Tinca tinca</i>		3		3
<i>Perca fluviatilis</i>	48	4	76	128
<b>Total</b>	<b>160</b>	<b>45</b>	<b>158</b>	<b>363</b>



surface area of 58,000 hectares and its maximum depth reaches 310 m. The fish community is halfway between the two others; perch, salmonids and cyprinids are of equal importance (GERDEAUX 1990).

A total of 363 fishes of 9 species was examined in September 1997 and June 1998 (Table 1). Fish were caught by local fishermen using gill nets or by angling. Digestive tracts were removed, placed into boxes with ice, transported to the laboratory and examined the same or next day. The worms found were fixed by hot 4% formalin and nematodes by hot 4% solution of formalin and saline, identified and counted. Voucher specimens have been deposited in the helminthological collections of the Natural History Museums in Paris and Geneva; and at the Institute of Parasitology, České Budějovice. Some additional records from the collection (INVE) of the Natural History Museum of Geneva are included.

## RESULTS

A total of 11 species of endoparasitic helminths was found: 2 species of trematodes (Digenea), 7 species of tapeworms (Cestoda), 1 nematode (Nematoda) and 1 spiny-headed worm (Acanthocephala).

### DIGENEA

#### 1. *Asymphylodora tincae* (Modeer, 1790)

*Host:* tench (*Tinca tinca*).

*Site:* intestine.

*Locality:* Bourget, June 1998 (infected 2 of 3 fish examined; intensity of infection 3-296).

*Comments:* This is a frequent parasite specific to tench, occurring in the Palearctic Region (BYKHOVSKAYA-PAVLOVSKAYA & KULAKOVA 1987). The life cycle of this trematode includes only one intermediate host, a lymnaeid snail, in which tailless cercariae (cercariaeum) develops. The fish acquire infection after consuming the snail harbouring cercariae (NAŠINCOVÁ & SCHOLZ 1994).

#### 2. *Bunodera luciopercae* (Müller, 1776)

*Host:* perch (*Perca fluviatilis*).

*Site:* intestine.

*Locality:* Annecy, September 1997, June 1998 (12/48; 41.8; 3-100).

*Comments:* *B. luciopercae* is a typical intestinal parasite of percid fishes in Europe and the ex-USSR, with perch representing the most suitable host (BYKHOVSKAYA-PAVLOVSKAYA & KULAKOVA 1987). In some regions, the parasite exhibits marked seasonal patterns in the occurrence and maturation (see CHUBB 1979 for review). The life cycle includes 2 intermediate hosts (YAMAGUTI 1975).

## CESTODA

3. **Caryophyllaeus laticeps** (Pallas, 1781)

*Host*: roach (*Rutilus rutilus*).

*Site*: intestine.

*Locality*: Annecy, September 1997, (one of 10 fish examined infected with 1 juvenile cestode).

*Comments*: It seems that this tapeworm, which is rather common parasite of cyprinid fishes in Europe and Eurasia (DUBININA 1987), is quite rare in the lakes studied. In Geneva Lake, it was not present in any of 40 roach examined in June 1995 and September 1997. Oligochaetes (Tubificidae) serve as intermediate hosts of this parasite (SEKUTOWITCZ 1932).

4. **Eubothrium crassum** (Bloch, 1779)

*Hosts*: lake trout (*Salmo trutta* m. *lacustris*); perch as paratenic host.

*Site*: intestine.

*Localities*: lake trout: Annecy, September 1997, June 1998 (8/8; 47.8; 4-172; of these, 358 adult specimens and 24 juvenile ones); Bourget, September 1997, June 1998 (4/4; 59.8; 35-89; 239 adults and 48 juvenile tapeworms); perch: Annecy, September 1997, June 1998 (4/48; 1.5; 1-3 juvenile specimens); Bourget, September 1997 (1/4; more than 50 juveniles).

*Comments*: *E. crassum* is a common parasite of salmonoid fishes, widely distributed in the Holarctic with two biological races, one freshwater and one marine (KENNEDY 1978a,b). In Europe, *E. crassum* occurs from the Arctic part of Norway to southern France and Switzerland (VIK 1963; KENNEDY 1978b, 1996). JOYEUX & BAER (1936) reported *E. crassum* from trout in Geneva Lake. Trout (*Salmo trutta*) is considered to be preferred host of the cestode, with prevalence often reaching 70-100% (WOOTTEN 1972). In the present study, *E. crassum* has not been recorded in the lake trout from Geneva lake (four hosts examined). However, this parasite is common in the lake trout as indicated by recent samples from the Geneva Museum collection: Chens, 16.01.1992, 24.04.1998; Genthod 22-23.01.1992; Prangins, 08.03.1992; Hermance, 31.03.1993; Tougues, 14.01.1996; Coppet, 18.01.1998. Prevalence: 8/9.

In Annecy and Bourget lakes adult tapeworms were found exclusively in lake trout, whereas juveniles with the beginning of segmentation occurred in trout and perch. On the basis of the presence of juvenile tapeworms in prey fish as perch, ruff (*Gymnocephalus cernuus*) or three-spined stickleback (*Gasterosteus aculeatus*), it was supposed that two intermediate hosts are involved in the life cycle of this cestode (ROSEN 1918; JOYEUX & BAER 1936; AKHMEROV 1962). However, field data (VIK 1963; WOOTTEN 1972; REIMER 1984) indicate that there is only one obligatory intermediate host, a copepod, and prey fish serve as paratenic hosts (KENNEDY 1978a,b). JOYEUX & BAER (1936) reported common occurrence of juvenile *Eubothrium* tapeworms from several fish species in Geneva Lake. Although these juvenile cestodes could not be identified, it can be assumed that they might belong to *E. crassum*.

### 5. *Eubothrium salvelini* Schrank, 1790

*Host*: Arctic char (*Salvelinus alpinus*).

*Site*: intestine.

*Localities*: Annecy, September 1997, June 1998 (34/34; 19.6; 1-60; 458 adult specimens and 209 juveniles); Bourget, September 1997, June 1998 (16/16; 19.4; 2-39; 283 adults and 27 juveniles).

*Comments*: *E. salvelini* is considered a specific parasite of Arctic char in Europe and Eurasia, with its distribution largely coincident with that of its host (KENNEDY 1978a,b). It is a fairly common parasite of Arctic char and it has been reported from this fish species in Switzerland and France (JOYEUX & BAER 1936; GERDEAUX *et al.* 1995), Austria (RYDLO 1970, 1985; KRITSCHER 1991), Germany (REIMER 1984; HOFFMANN *et al.* 1986a; ENGELHARDT & MIRLE 1993) as well as in northwestern Europe (NYBELIN 1922; WOOTTEN 1972; KENNEDY 1978a,b; KRISTOFFERSEN 1995; KNUDSEN *et al.* 1997). Similar to the present study, high prevalence (70-100%) and intensity of infection (up to 60 worms) were reported in other localities (SOBECKA & PIASECKI 1993), including Alpine lakes (REIMER 1984). In North America it occurs also in other salmonid fishes as *Oncorhynchus* (SMITH 1973; KENNEDY 1978a,b; BOYCE 1979; MUZZAL 1995).

It has been demonstrated experimentally (BOYCE 1974) that copepods serve as the only intermediate hosts. Field data suggest that the infection level and its variation among individual localities depend largely upon proportion of planktonic copepods in the food of Arctic char (REIMER 1984). In contrast to *E. crassum*, no juvenile tapeworms were found in other fish than Arctic char during the present study.

### 6. *Proteocephalus longicollis* (Zeder, 1800)

*Host*: whitefish (*Coregonus lavaretus*).

*Site*: intestine.

*Localities*: Annecy, September 1997, June 1998 (36/40; 113 adults and a great number of juvenile cestodes, with intensity of infection ranging from 17 to more than 1000 (precise number not counted); Bourget, September 1997, June 1998 (11/14; 7.8; 1-30; 60 adults and 26 juveniles); Geneva Lake, September 1997 (8/21; 14.9; 2-58; 36 adults and 233 juveniles).

*Comments*: It has been demonstrated that *P. longicollis* (syns. *P. exiguus*, *P. fallax* and *P. neglectus*) is the only *Proteocephalus* species occurring in salmonid and coregonid fishes in Europe (SCHOLZ & HANZELOVÁ 1998). It is a highly variable species occurring in a wide range of fishes including brown, rainbow and brook trouts and whitefish (HANZELOVÁ *et al.* 1995, 1996; SCHOLZ & HANZELOVÁ 1998). In the lakes investigated, adult worms were found exclusively in the intestine of whitefish whereas Arctic char and lake trout were free of *P. longicollis* infection. However, a fry of Arctic char and lake trout from a hatchery on Annecy lake were heavily infected with *P. longicollis* (D. Gerdeaux - unpublished data). JOYEUX & BAER (1936) also reported *P. longicollis* from lake trout, Arctic char and whitefish in Geneva Lake. *Proteocephalus* tapeworms, most probably conspecific with *P. longicollis*, were found in whitefish from Geneva Lake by DOBY & JARECKA (1964), and MORANDI & PONTON (1989).

Intermediate hosts of *P. longicollis* are planktonic copepods (see SCHOLZ 1999 for review). In Geneva Lake, *Cyclops strenuus* and *C. abyssorum* have been reported as intermediate hosts of *Proteocephalus* sp. (most probably *P. longicollis*) by JARECKA & DOBY (1965). In Annecy lake, *Cyclops prealpinus* serves as dominant intermediate host of this parasite (V. Hanzelová - unpublished data).

A high number of metacystodes was found in whitefish in all three lakes. Much lower number of adult worms in these fish indicates that only a very small proportion of juvenile worms reaches maturity (about 0.5-1% estimated for *P. filicollis* – HOPKINS 1959).

### 7. *Proteocephalus percae* (Müller, 1780)

*Hosts*: perch (*Perca fluviatilis*); burbot (*Lota lota*) as alternative host.

*Site*: intestine.

*Localities*: perch: Annecy, September 1997, June 1998 (27/48; 6.4; 1-53); Bourget, September 1997, June 1998 (2/4; 4 and more than 100 juveniles); Geneva, June 1996 (20/76; 2.2; 1-14); burbot: Annecy, June 1998 (2/18; 2.5; 1-4).

*Comments*: *P. percae* is a common parasite of perch, reported also from other percid fish in the Palearctic (SCHOLZ & HANZELOVÁ 1998). In lakes under consideration, it occurs fairly frequently in perch. Burbot represents only an alternative, probably postcyclic host of *P. percae*. It is known that predatory fishes as pike, trout, eel or burbot may harbour *P. percae* tapeworms and serve as alternative (paradefinitive, postcyclic or accidental) hosts (SCHOLZ 1998). Life cycle of this cestode involves a copepod intermediate hosts (WOOTTEN 1974).

### 8. *Proteocephalus torulosus* (Batsch, 1786)

*Host*: bleak (*Alburnus alburnus*).

*Site*: intestine.

*Locality*: Geneva, June 1995 (1/1; 1).

*Comments*: This is a typical parasite of cypriniform fishes (Cyprinidae and Cobitidae), occurring in Europe, Asia and western part of North America (SCHOLZ & HANZELOVÁ 1998). It occurs preferably in riverine ecosystems rather than in lakes. Only one bleak was examined in this study and it is possible that *P. torulosus* occurs more frequently in the lakes studied. JOYEUX & BAER (1936) also reported bleak as the definitive host of this tapeworm from Geneva Lake. Intermediate hosts of *P. torulosus* are planktonic copepods, in particular *Cyclops* spp. (WAGNER 1917; SCHOLZ 1993).

### 9. *Triaenophorus nodulosus* (Pallas, 1781)

*Hosts*: pike (*Esox lucius*); perch as the second intermediate host.

*Sites*: intestine (adult tapeworm); liver (plerocercoids in perch).

*Localities*: pike: Annecy, June 1998 (1/2; 12); perch: Annecy, September 1997, June 1998 (20/48; 3.5; 1-10); Geneva, June 1995 (number not counted).

*Comments*: *T. nodulosus* is a specific parasite of pike in the Palearctic Region (KUPERMAN 1973). It frequently occurs in Alpine lakes in Austria and Germany (RYDLO

1985; HOFFMANN *et al.* 1986b). The life cycle of this cestode includes two intermediate hosts, a copepod in which a proceroid develops, and a fish where a plerocercoid is encysted in the liver. Infection level with adults and plerocercoids in fishes from the lakes studied is fairly low compared to other localities (see CHUBB 1982 for review).

#### NEMATODA

##### 10. *Cammallanus lacustris* (Zoega, 1776)

*Hosts:* perch (*Perca fluviatilis*), burbot (*Lota lota*).

*Site:* intestine.

*Localities:* perch: Annecy, September 1997, June 1998 (36/48; 8.1; 1-44); Bourget, September 1997, June 1998 (4/4; 11.3; 4-21); Geneva, June 1995 (number not counted); burbot: Annecy, June 1998 (5/18; 3.2; 1-6).

*Comments:* *C. lacustris* is a quite common parasite of predatory fish as pike, perch or burbot, widely distributed in the Palearctic Region (MORAVEC 1994). In Annecy and Bourget lakes, perch is apparently the principal host of this nematode, which develops through planktonic copepods (MORAVEC 1994). The absence of nematodes in pike from the lakes concerned may be related to the low number of fish examined.

#### ACANTHOCEPHALA

##### 11. *Acanthocephalus lucii* (Müller, 1780)

*Hosts:* perch (*Perca fluviatilis*), pike (*Esox lucius*), burbot (*Lota lota*).

*Site:* Intestine.

*Localities:* perch: Annecy, September 1997, June 1998 (31/48; 9.6; 1-65); Bourget, September 1997, June 1998 (3/4; 2.0; 1-4); Geneva, June 1995 (number not counted); pike: Annecy, June 1998 (1/2; 6); burbot: Annecy, June 1998 (5/18; 3.2; 1-6).

*Comments:* *A. lucii* is a very frequent parasite occurring in a wide spectrum of fishes of different families in the Palearctic Region (BAUER 1987). In the lakes studied, it forms an important part the helminth fauna of perch and occurs commonly also in burbot and pike. Intermediate host of *A. lucii* is the isopod *Asellus aquaticus* (KOMAROVA 1950).

#### DISCUSSION

A total of 11 species of endohelminths was found in fishes from the three Alpine lakes studied. The most characteristic feature of these helminth communities is a high number (7) of cestode species, which represents the dominant part of the helminth fauna in all localities. Prevalence of *E. salvelini*, *E. crassum* and *P. longicollis* in Arctic char, lake trout and whitefish, respectively, reached 90-100%, and intensity of infection was also considerably high. Common occurrence of *Eubothrium* tapeworms and *P. longicollis* have also been reported from other lakes in the Alps and from northern Europe (KENNEDY 1978a,b; REIMER 1984; BRISTOW & BERLAND 1991; KRISTOFFERSEN 1995).

Considering existing literature data on the helminth fauna of fishes from the lakes studied, it is worth of mention that two other tapeworms, reported by JOYEUX & BAER (1936) from Geneva Lake, have not been found in this study. Instead of *Triaenophorus crassus*, *T. nodulosus* has been found. It is possible that former species is rather rare in pike population. The absence of *Cyathocephalus truncatus*, in our samples, a parasite which was reported from trout, whitefish and burbot by JOYEUX & BAER (1936), is difficult to explain. Since these authors did not provide data on the infection rate, occurrence of *C. truncatus* in Geneva Lake cannot be excluded with certainty.

#### ACKNOWLEDGMENTS

The authors wish to thank to Ms. Valerie Hamelet, INRA, Thonon for help in field, and to Mr. Jacquet and Mr. Coutin, for providing fish. This study was supported by INRA (project No. 24-25/98), Grant Agency of the Slovak Republic VEGA (project No. 2/5018/98) and Grant Agency of the Czech Republic (project Nos 206/98/0591 and 524/98/0940).

#### REFERENCES

- AKHMEROV, 1962. On the biology of the cestode *Eubothrium crassum* (Bloch, 1779). *Trudy GELAN* 12: 5-8. (In Russian).
- BAUER, O.N. (ed.) 1987. Key to the parasites of freshwater fishes. Volume 2, Part 2. *Nauka, Leningrad*, 588 pp. (In Russian).
- BOYCE, N.P.J. 1974. Biology of *Eubothrium salvelini* (Cestoda: Pseudophyllidea), a parasite of juvenile sockeye salmon (*Oncorhynchus nerca* of Babine Lake, British Columbia. *Journal of the Fisheries Research Board of Canada*, Ottawa 31: 1735-1742.
- BOYCE, N.P.J. 1979. Effects of *Eubothrium salvelini* (Cestoda: Pseudophyllidea) on the growth and vitality of sockeye salmon, (*Oncorhynchus nerca*). *Canadian Journal of Zoology* 57: 597-602.
- BRISTOW, G.A. & BERLAND, B. 1991. The effect of long term, low level of *Eubothrium* sp. (Cestoda: Pseudophyllidea) infection on growth in farmed salmon (*Salmo salar* L.). *Aquaculture* 98: 325-330.
- BYKHOVSKAYA-PAVLOVSKAYA, E.I. & KULAKOVA, V.P. 1987. Trematoda. In: BAUER, O.N. (ed.), Key to the parasites of freshwater fishes. Volume 2, Part 2. *Nauka, Leningrad*, pp. 92-167. (In Russian).
- CHUBB, J.C. 1979. Seasonal occurrence of helminths in freshwater fishes. Part II. Trematoda. *Advances in Parasitology* 17: 141-313.
- CHUBB, J.C. 1982. Seasonal occurrence of helminths in freshwater fishes. Part IV. Adult Cestoda, Nematoda and Acanthocephala. *Advances in Parasitology*. 20: 1-292.
- DOBY, J.M. & JARECKA, L. 1964: Complément à la connaissance de la morphologie et de la biologie de *Proteocephalus macrocephalus* (Creplin, 1825), cestode parasite de l'anguille. *Annales de parasitologie humaine et comparée* 41: 429-442.
- DUBININA, M.N. 1987. Class Cestoda Rudolphi, 1808. In: BAUER, O.N. (ed.). Key to the parasites of freshwater fishes. Volume 2, Part 2. *Nauka, Leningrad*, pp. 5-76. (In Russian).
- ENGELHARDT, A. & MIRLE, C. 1993. On the formation of the cestode fauna of rainbow trout (*Oncorhynchus mykiss*) in a recently emerged rest waters from an open-cast mine. *Applied Parasitology* 34: 33-49.

- GERDEAUX, D. 1990. Fisheries management in an international lake: Lake Geneva. In: VAN DENSEN, W.L.T., STEINMETZ, B. & HUGHES, R.H. (eds.), Management of freshwater fisheries. *Proc. symp. EIFAC, 1988. Göteborg, Sweden*, pp. 168-181.
- GERDEAUX, D., FILLON, M.A. & VAN OVERMEIRE, L. 1995. Arctic charr, *Salvelinus alpinus*, of Lake Annecy: yield, growth and parasitism by *Eubothrium salvelini*. *Nordic Journal of Freshwater Research* 71: 245-251.
- HANZELOVÁ, V., SCHOLZ, T. & FAGERHOLM, H.-P. 1995. Synonymy of *Proteocephalus neglectus* La Rue, 1911, with *P. exiguus* La Rue, 1911, two fish cestodes from the Holarctic Region. *Systematic Parasitology* 30: 173-185.
- HANZELOVÁ, V., ŠNÁBEL, V. & ŠPARKULOVÁ, M. 1996. On the host specificity of fish tapeworm *Proteocephalus exiguus* La Rue, 1911 (Cestoda). *Parasite* 3: 253-257.
- HOFFMANN, R.W., KENNEDY, C.R. & MEDER, J. 1986a. Effects of *Eubothrium salvelini* Schrank, 1790, on Arctic charr, *Salvelinus alpinus* (L.), in an Alpine lake. *Journal of Fish Diseases* 9: 153-157.
- HOFFMANN, R.W., MEDER, J., KLEIN, M., OSTERKORN, K. & NEGELE, R.D. 1986b. Studies on lesions caused by plerocercoides of *Triaenophorus nodulosus* in some fish of an alpine lake, the Königsee. *Journal of Fish Biology* 28: 701-712.
- HOPKINS, C.A. 1959. Seasonal variation in the incidence and development of the cestode *Proteocephalus flicollis* (Rud. 181) in *Gasterosteus aculeatus* (L.1768). *Parasitology* 49: 529-542.
- JARECKA, L. & DOBY, J.M. 1965. Contribution à l'étude du cycle évolutif d'un cestode du genre *Proteocephalus* parasite de *Coregonus fera* en provenance de Lac Léman. *Annales de parasitologie humaine et comparée* 40: 433-443.
- JOYEUX, C. & BAER, J.G. 1936. Cestodes. *Faune de France* 30. Paris, 613 pp.
- KENNEDY, C.R. 1978a. Studies on the biology of *Eubothrium salvelini* and *E. crassum* in resident and migratory *Salvelinus alpinus* and *Salmo trutta* and in *Salmo salar* in North Norway and the islands of Spitsbergen and Jan Mayen. *Journal of Fish Biology* 12: 147-162.
- KENNEDY, C.R. 1978b. The biology, specificity and habitat of the species of *Eubothrium* (Cestoda: Pseudophyllidea), with reference to their use as biological tags: a review. *Journal of Fish Biology* 12: 393-410.
- KENNEDY, C.R. 1996. Establishment, survival and site selection of the cestode *Eubothrium crassum* in brown trout, *Salmo trutta*. *Parasitology* 112: 347-355.
- KNUDSEN, R., KRISTOFFERSEN, R. & AMUNDSEN, P.-A. 1997. Parasite communities in two sympatric morphs of Arctic charr, *Salvelinus alpinus* (L.), in northern Norway. *Canadian Journal of Zoology* 75: 2003-2009.
- KOMAROVA, M.S. 1950. On the life cycle of *Acanthocephalus lucii* Müller. *Doklady Akademii Nauk SSSR, seria biologia* 70: 359-360. (In Russian).
- KRISTOFFERSEN, R. 1995. Temporal changes in parasite load of lake resident Arctic charr *Salvelinus alpinus* (L.) held in brackish water cage culture. *Nordic Journal of Freshwater Research* 70: 49-55.
- KRITSCHER, E. 1991. Beitrag zur Kenntniss der Parasiten des Seeablings *Salvelinus alpinus salvelinus* L. (Pisces: Salmonidae) aus dem Attersee (Oberösterreich). *Annalen des Naturhistorischen Museums Wien* 92B: 257-265.
- KUPERMAN, B.I. 1973. Tapeworms of the genus *Triaenophorus*, parasites of fishes. *Nauka, Leningrad*, 208 pp. (In Russian).
- MORANDI, H. & PONTON, D. 1989. Cycle évolutif d'un cestode Proteocephalidae parasite de corégone du Lac Léman (*Coregonus lavaretus* L.). *Annales de parasitologie humaine et comparée* 64: 257-267.
- MORAVEC, F. 1994. Parasitic nematodes of freshwater fishes of Europe. *Academia & Kluwer, Prague and Dordrecht*, 473 pp.
- MUZZAL, P.M. 1995. Parasites of lake trout, *Salvelinus namaycush*, from the Great Lakes: a review of the literature 1874-1994. *Journal of Great Lakes Research* 21: 594-598.

- NAŠINCOVÁ, V. & SCHOLZ, T. 1994. The life cycle of *Asymphylogora tincae* (Modeer, 1790) (Trematoda: Monorchiiidae): a unique development in monorchiid trematodes. *Parasitology Research* 80: 192-197.
- NYBELIN, O. 1922. Anatomisch-systematisch Studien über Pseudophyllidien. *Göteborgs Kungl. Vetenskaps och Vitterhets Samhälles Handlingar* 26: 1-228.
- REIMER, G. 1984. Beobachtungen zum Bandwurmbefall von Seesaiblingen (*Salvelinus alpinus*). *Österreichische Fischerei* 37: 233-234.
- ROSEN, E. 1918. Sur le développement de *Bothriocephalus*. *Bulletin de la Société des Sciences de Nenchâtel* 19: 167-198.
- RYDLO, M. 1970. Parasitologische Untersuchungen an Salmoniden aus einem Alpensee in Oberösterreich. *Österreichische Fischerei* 23: 1-4.
- RYDLO, M. 1985. Die Bedeutung von Parasiten als Indikator für die Ernährungsweise des Wirtes am Beispiel von Seelaube (*Chalcalburnus chalcoides mento*), Russnase (*Vimba vimba elongata*) und Seesaibling (*Salvelinus alpinus*). *Österreichische Fischerei* 38: 279-283.
- SCHOLZ, T. 1993. Development of *Proteocephalus torulosus* (Batsch, 1786) (Cestoda: Proteocephalidae) in the intermediate host under experimental conditions. *Journal of Helminthology* 67: 316-324.
- SCHOLZ, T. 1999. Life-cycles of species of *Proteocephalus* Weinland, 1858 (Cestoda: Proteocephalidae), parasites of freshwater fishes in Palearctic Region: a review. *Journal of Helminthology* 73: 1-19.
- SCHOLZ, T. & HANZELOVÁ, V. 1998. Tapeworms of the genus *Proteocephalus* Weinland, 1858 (Cestoda: Proteocephalidae), parasites of fishes in Europe. *Směrnice AV CR, Academia Praha*, 118 pp.
- SEKUTOWICZ, S. 1932. Study on development and biology of *Caryophyllaens laticeps* (Pall.). *Mémoires de l'Académie polonaise des Sciences. Classe des Sciences mathématiques et naturelle* 6: 11-26.
- SMITH, H.D. 1973. Observations on the cestode *Eubothrium salvelini* in juvenile sockeye salmon (*Oncorhynchus nerka*) at Babine Lake, British Columbia. *Journal of the Fisheries Research Board of Canada, Ottawa* 30: 947-964.
- SOBECKA, E. & PIASECKI, W. 1993. Parasitic fauna of Arctic charr, *Salvelinus alpinus* (L., 1758) from the Hornsund Region (Spitsbergen). *Acta Ichthyologica et Piscatoria* 23: 99-106.
- VIK, R. 1963. Studies on the helminth fauna of Norway. IV. Occurrence and distribution of *Eubothrium crassum* (Bloch 1779) and *E. salvelini* (Schrank 1790) (Cestoda) in Norway, with notes on their life cycles. *Nytt Magazin for Zoologi, Oslo* 11: 47-73.
- WAGNER, O. 1917. Über den Entwicklungsgang und Bau einer Fischtäenie (*Ichthyotaenia torulosus* Batsch). *Jenaische Zeitschrift für Naturwissenschaft* 55: 1-66.
- WOOTEN, R. 1972. Occurrence of *Eubothrium crassum* (Bloch, 1779) (Cestoda: Pseudophyllidae) in brown trout *Salmo trutta* L., and rainbow trout *S. gairdneri* Richardson, 1836, from Hanningfield Reservoir, Essex. *Journal of Helminthology* 46: 327-339.
- WOOTEN, R. 1974. Studies on the life history and development of *Proteocephalus percae* (Müller) (Cestoda: Proteocephalidae). *Journal of Helminthology* 48: 269-281.
- YAMAGUTI, S. 1975. A Synoptical Review of Life Histories of Digenetic Trematodes of Vertebrates. *Keigaku Publishing Co., Tokyo*, 590 pp.
- ZSCHOKKE, F. 1884. Recherches sur l'organisation et la distribution zoologique des vers parasites des poissons d'eau douce. *Archives de Biologie, Paris* 5: 153-241.



## Un nouveau genre et une nouvelle espèce de scorpion d'Égypte, appartenant à la famille des Buthidae Simon

Wilson R. LOURENÇO

Laboratoire de Zoologie (Arthropodes), Muséum national d'Histoire naturelle, 61, rue de Buffon, F-75005 Paris, France; e-mail: arachne@mnhn.fr

**New genus and new species of scorpion from Egypt, belonging to the family Buthidae Simon.** - The new genus *Egyptobuthus* and the new species *Egyptobuthus vaissadei* belonging to the Buthidae family are described from Egypt. This new genus is probably an enclaved endemic element, isolated from the typical saharian and perisaharian faunas. Its discovery represents an interesting contribution to the knowledge of the distributional patterns and affinities of some elements of the African and Northern African faunas.

**Key-words:** Scorpion - Buthidae - new genus - new species - Egypt - endemism.

### INTRODUCTION

Dans l'ensemble de l'ordre Scorpiones, des 15 familles reconnues à l'heure actuelle (LOURENÇO 1998a, b), celle des Buthidae Simon est de loin la plus importante, tant pour le nombre d'espèces, que par le nombre de genres reconnus. SISSOM (1990) signale un total de 50 genres valables au sein de la famille des Buthidae. Ce nombre cependant ne cesse de croître, et depuis la synthèse présentée par Sissom, plus d'une dizaine de nouveaux genres de Buthidae ont été créés (e.g. KOVARIK 1995, 1996, 1997a, b, 1998; LOURENÇO 1995a, 1996a, 1997a, b, 1998c; LOURENÇO & VACHON 1995, 1997).

Il est vrai qu'une relative majorité des nouveaux taxa génériques créés correspondent à des scorpions pouvant être classés comme des micro-buthidés. Ceci est le cas des *Microcharmus* Lourenço et *Pseudouroplectes* Lourenço de Madagascar ou encore *Himalayotityobuthus* Lourenço de l'Himalaya. Dans ces cas précis, leur petite taille peut expliquer leur découverte tardive, qui n'a pu être possible qu'à travers l'utilisation des techniques de collecte et d'extraction plus sophistiquées telles celles de Winkler, ou de lavage de sols, méthodes rarement utilisées pour la collecte des scorpions.

Par contre, la découverte de certains nouveaux genres de taille standard (3 à 6 cm), pourrait s'expliquer soit par: (i) l'extrême rareté des individus d'une population donnée, soit (ii) une meilleure résolution des caractères génériques valables en parallèle avec une connaissance plus précise de l'ensemble des groupes génériques de la famille donnée.

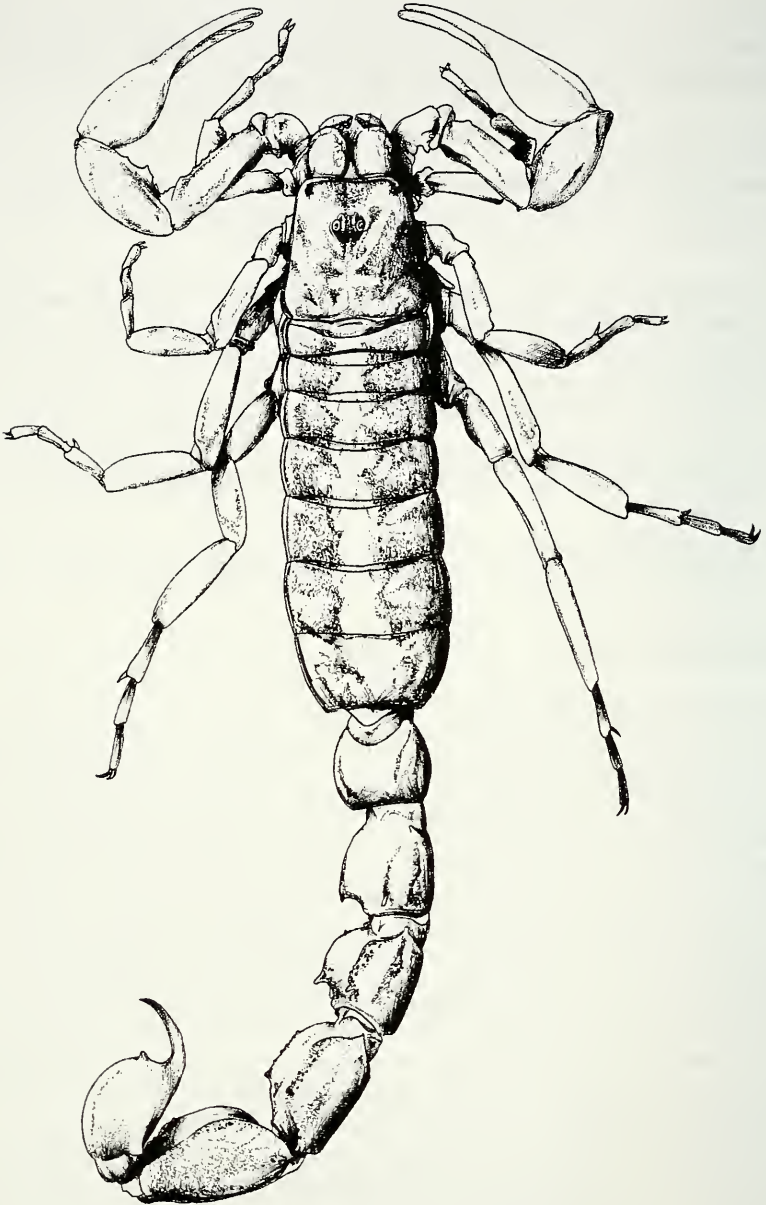

FIG. 1.

Habitus d'*Egyptobuthus vaissadei*, holotype femelle.

L'étude d'une petite collection comprenant entre autres quelques scorpions d'Egypte nous a permis de déceler un curieux scorpion appartenant à un nouveau genre et à une espèce nouvelle. Ceci est d'autant plus intéressant si on tient compte du fait que la faune scorpionique des pays d'Afrique du Nord a été intensivement étudiée par divers auteurs (POCOCK 1895; SIMON 1910), et en particulier par VACHON (1952).

### **Egyptobuthus** n. gen.

*Espèce type: Egyptobuthus vaissadei* n. sp.

#### *Diagnose*

Scorpions de petite taille; longueur totale des adultes d'environ 30 mm. La morphologie générale rappelle en partie celle des genres *Butheoloides* Hirst et *Uroplectes* Peters. Granulation générale faiblement marquée. Carènes des Pédipalpes, corps et metasoma moyennement ou faiblement marquées; les dorsales des anneaux II à IV du metasoma avec un granule postérieur bien développé en forme de mamelon. Peignes avec fulcres; dent interne normale. Sternum pentagonal. Eperons tibiaux présents sur les pattes III et IV; éperons basitarsaux présents à la quatrième patte, mais réduits sur la troisième. Chélicères avec la dentition des Buthidae (VACHON 1963); dents basales du doigt mobile très discrètes; dent distale externe plus petite que la distale interne. Tranchant des doigts mobiles des mains des pédipalpes avec 12 séries de granules; les doigts sont très courbés comme ceux observés dans le genre *Darchenia* Vachon. Trichobothriotaxie du type A avec la disposition  $\alpha$  pour les trichobothries de la face dorsale du fémur des pédipalpes (VACHON 1973, 1975).

#### *Position du nouveau genre au sein de la famille des Buthidae*

Le nouveau genre *Egyptobuthus* présente quelques caractères proches de ceux retrouvés chez d'autres genres africains tels *Uroplectes* et *Darchenia*, mais globalement l'ensemble de ses caractères l'isolent au sein des Buthidae. Son apparence générale présente quelques similitudes avec le genre *Butheoloides*, cependant ce dernier est classé parmi les «micro-buthidés». Leurs points communs sont une anatomie générale très voisine, et la présence d'un sternum à forme pentagonale. Ce dernier caractère les place parmi les exceptions au sein des Buthidae, qui globalement présentent un sternum triangulaire. *Egyptobuthus* ne peut pas cependant être considéré comme un genre véritablement associé à *Butheoloides*. Ce dernier, faisant partie intégrale des «micro-buthidés» est en réalité associé à d'autres genres africains ou asiatiques tels *Orthochirus* Karsch, *Butheolus* Simon ou *Karasbergia* Hewitt. Ils ont tous en commun une structure cuticulaire non-granulée mais ponctuée sur le metasoma; ces ponctuations présentant en effet des structures sensorielles spécifiques (Fet *in litt.* Lourenço obs. pers.). Le genre *Egyptobuthus* ne présente pas ce type de structure sur la cuticule ds anneaux du metasoma, mais plutôt une structure plus classique, avec une granulation peu importante. Les affinités exactes du nouveau genre restent à préciser comme cela est le cas pour d'autres genres rares de Buthidae tel *Birulatus* Vachon, également connu uniquement de la zone de transition entre l'Afrique et le Moyen Orient (VACHON 1973; LOURENÇO sous presse).

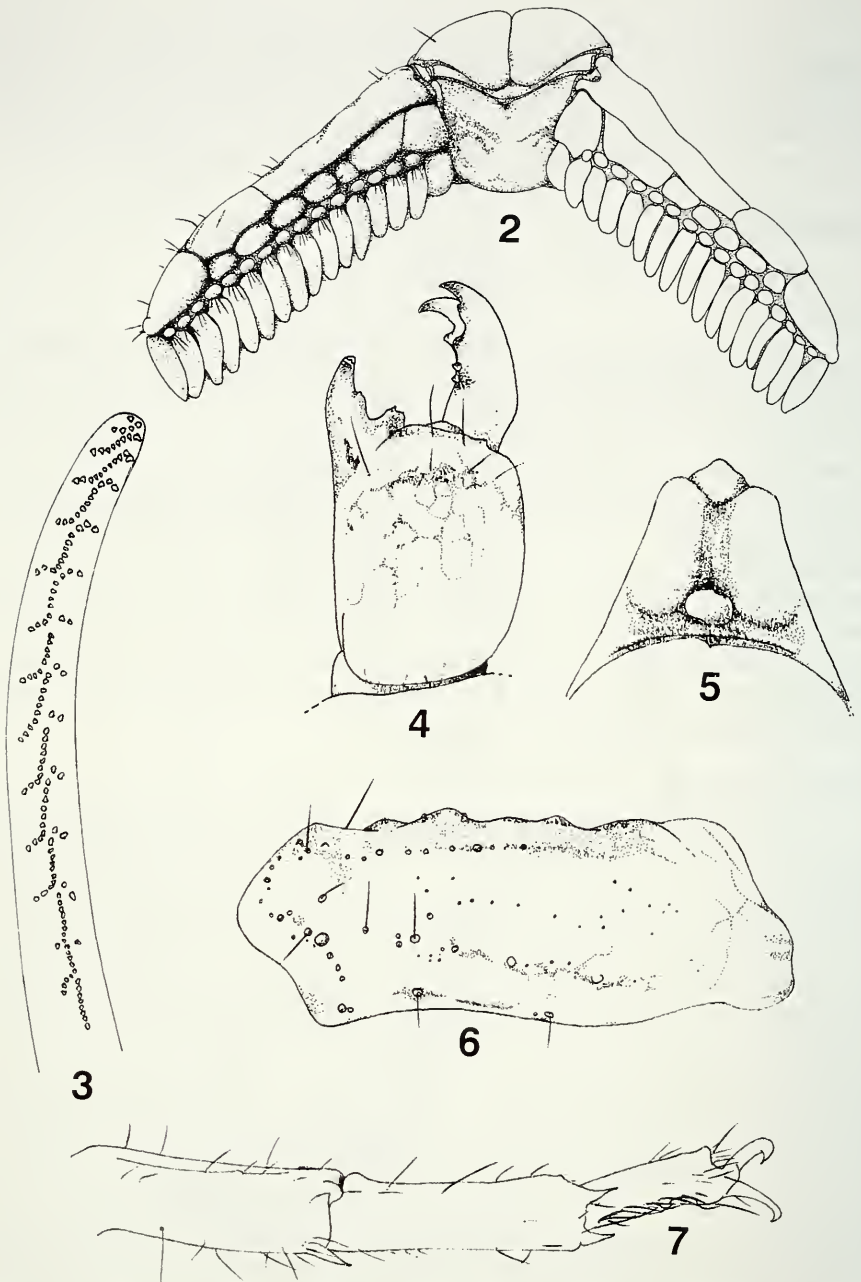

FIGS 2 à 7. *Egyptobuthus vaissadei*, holotype femelle. 2. Opercule génital et peignes. 3. Tranchant du doigt mobile des pédipalpes. 4. Chélicère avec la dentition caractéristique. 5. Sternum. 6. Fémur avec la disposition  $\alpha$  des trichobothries dorsales. 7. Extrémité de la patte IV, avec les éperons tibial et basitarsaux.

En ce qui concerne la répartition géographique respective des deux genres, *Butheoloides* apparaît comme un élément typiquement péri-saharien. Sans reprendre ici la totalité des considérations biogéographiques sur le genre *Butheoloides* (LOURENÇO 1995b, 1996b), il me paraît utile de les résumer brièvement.

Lors de sa création par Hirst le genre *Butheoloides* n'était connu que par la seule espèce *B. maroccanus* Hirst, habitant les flancs des montagnes de l'Atlas dans la région sud de Marrakech au Maroc, donc à l'extrémité Nord-occidentale de l'Afrique. Par la suite, avec la découverte de deux nouvelles espèces (*Butheoloides milloti* Vachon, des falaises de Bandiagara au Mali et *Butheoloides monodi* Vachon, décrite de l'ouest du Sénégal) la répartition du genre s'est élargie vers le Sud et l'Est du continent africain, affichant déjà une répartition du type péri-saharienne. Bien plus tard avec la description de *Butheoloides annieae* Lourenço de la Côte d'Ivoire, de *Butheoloides wilsoni* Lourenço du Burkina Faso, de *Butheoloides polisi* Lourenço d'Ethiopie et de *Butheoloides hirsti* Lourenço du Soudan, ce modèle de répartition s'est de plus en plus confirmé.

*Egyptobuthus*, au contraire, semble être un élément isolé dans une des zones refuges présentes sur les régions arides du Sahara et du Moyen Orient, comme c'est le cas du genre *Birulatus*, dont la distribution est limitée à des régions refuges en Jordanie et Israël (LOURENÇO sous presse).

### ***Egyptobuthus vaissadei* n. sp.**

Holotype femelle: Egypte, région nord du Sinaï, proche ds côtes de la Mer Rouge, II-1997 (H.-W. Herrmann) collecté avec un exemplaire de *Buthus occitanus* Amoureux). Déposé au Muséum d'histoire naturelle de Genève.

Étymologie: Le nom spécifique est créé en hommage à M. Alain Vaissade, Conseiller administratif de la Ville de Genève.

#### *Description*

Coloration générale jaunâtre avec des taches brunâtres. Plaque prosomienne jaunâtre avec des taches brunâtres, surtout dans la région antérieure. Mesosoma jaunâtre avec deux bandes longitudinales brunâtres qui commencent dans la partie distale de la plaque prosomienne et se prolongent sur le mesosoma, s'élargissant vers l'arrière. Anneaux metasomaux I à III jaunâtres; IV et V plus foncés, jaune-rougeâtre; présence de taches brunâtres longitudinales sur tous les anneaux. Vésicule jaunâtre avec des taches brunâtres très estompées; aiguillon avec la base jaunâtre et à l'extrémité rougeâtre. Peignes, opercule génital, sternum, hanches et processus maxillaire ocre-jaune. Pattes jaunâtres avec des taches brunâtres très estompées; pédipalpes jaunâtres, avec des nuances de taches brunâtres. Chélicères jaunâtres avec la présence d'un trame brun-rougeâtre faiblement marqué.

Morphologie. Prosoma: front de la plaque prosomienne avec une concavité très peu profonde, presque droit; tubercule oculaire très antérieur par rapport au centre de la plaque prosomienne; yeux médians séparés par plus d'un diamètre oculaire; trois paires d'yeux latéraux; la première paire composée d'yeux plus petits. Carènes pratiquement absentes; granulations réduites à un minimum; tégument presque lisse. Mesosoma:



FIG. 8

Carte avec la distribution géographique péri-saharienne du genre *Butheoloides* (cercles noirs) et la localité-type d'*Egyptobuthus vaissadei* (étoile).

tergites pratiquement lisses, comme pour la plaque prosomienne. Carène axiale présente sur les tergites I à VI, mais faiblement marquée; pratiquement absente sur le VIIème où quatre autres carènes sont faiblement représentées. Metasoma: anneaux arrondis avec des granulations et des carènes peu marquées, surtout sur les trois premiers; carènes dorsales des anneaux II à IV avec une grosse épine postérieure, en forme de mamelon. Vésicule pratiquement lisse; aiguillon plus court que la vésicule, très incurvé, pourvu d'une épine sous-aiguillonnaire peu développée, également en forme de mamelon. Sternum pentagonal. Sternites à stigmates petits et aplatis, linéaires. Peignes avec 17-16 dents; fulcres présents; lame basilaire intermédiaire non-dilatée. Pédipalpes: fémur à 5 carènes peu marquées; tibia et pince très lisses, avec des carènes presque imperceptibles. Douze séries de granules sur le tranchant des doigts mobiles. Chélicères avec la dentition des Buthidae (VACHON 1963); les deux dents basales du doigt mobile presque fusionnées et peu perceptibles; dent distale externe plus petite que la dent distale interne. Trichobothriotaxie du type A- $\alpha$  (VACHON 1973, 1975), orthobothriotaxique. Eperons tibiaux présents sur les pattes III et IV; éperons basitarsaux présents sur la patte IV et réduits sur la III.

TABLEAU I  
Mensurations (en mm) de l'holotype d'*Egyptobuthus vaissadei*

Prosoma	
- Longueur	3,2
- Largeur antérieure	2,3
- Largeur postérieure	3,4
Anneau caudal I	
- Longueur	1,8
- Largeur	2,2
Anneau caudal V	
- Longueur	3,4
- Largeur	2,2
- Hauteur	2,0
Vésicule	
- Largeur	2,0
- Hauteur	1,7
Pédipalpe	
- Fémur longueur	2,6
- Fémur largeur	1,0
- Tibia longueur	3,2
- Tibia largeur	1,5
- Pince longueur	5,2
- Pince largeur	1,4
- Pince hauteur	1,2
Doigt mobile	
- Longueur	3,3

## REMERCIEMENTS

Je suis très reconnaissant à M. Philippe Bouchard, Muséum national d'Histoire naturelle, Paris pour sa contribution à la réalisation de plusieurs dessins illustrant le présent travail, au Dr Sabine Jourdan (Paris) pour la lecture du manuscrit et à M. T. Ziegler (Bonn) pour m'avoir confié à l'étude le spécimen décrit.

## BIBLIOGRAPHIE

- KOVARIK, F. 1995. Review of Scorpionida from Thailand with descriptions of *Thaicharmus mahunkai* gen. et sp. n. and *Lychas krali* sp. n. (Buthidae). *Acta Societatis zoologicae Bohemicae* 59: 187-207.
- KOVARIK, F. 1996. *Baloorthochirus becvari* gen. et sp. n. from Pakistan, and taxonomic position of *Orthochirus luteipes* (Scorpiones: buthidae). *Acta Societatis zoologicae Bohemicae* 60: 177-181.
- KOVARIK, F. 1997a. *Afroisometrus* gen. n. from Zimbabwe (Scorpiones: Buthidae). *Acta Societatis zoologicae Bohemicae* 61: 35-37.
- KOVARIK, F. 1997b. Results of the Czech Biological Expedition to Iran. Part 2. Arachnida: Scorpiones, with descriptions of *Iranobuthus krali* gen. n. et sp. n. and *Hottentotta zagrosensis* sp. n. (Buthidae). *Acta Societatis zoologicae Bohemicae* 61: 39-52.
- KOVARIK, F. 1998. Three new genera and species of Scorpiones (Buthidae) from Somalia. *Acta Societatis zoologicae Bohemicae* 62: 115-124.

- LOURENÇO, W. R. 1995a. Description de trois nouveaux genres et de quatre nouvelles espèces de scorpions Buthidae de Madagascar. *Bulletin du Muséum national d'Histoire naturelle, Paris*, 4e sér. 17 (A-1-2): 95-106.
- LOURENÇO, W. R. 1995b. Considérations sur la répartition géographique du genre *Butheoloides* Hirst avec la description de *Butheoloides wilsoni* n. sp. (Scorpiones, Buthidae). *Bulletin du Muséum national d'Histoire naturelle, Paris*, 4e sér. 16 (A-2-4): 475-480.
- LOURENÇO, W. R. 1996a. A new genus and a new species of scorpion (Buthidae) from Iran. *Zoology in the Middle East* 12: 93-98.
- LOURENÇO, W. R. 1996b. A propos de deux espèces nouvelles appartenant au genre *Butheoloides* Hirst (Scorpiones, Buthidae). *Revue Arachnologique* 11 (9): 87-94.
- LOURENÇO, W. R. 1997a. A new genus and new species of Buthidae scorpion from Pakistan. *Entomologische Mitteilungen aus dem Zoologischen Museum Hamburg* 12 (155): 153-157.
- LOURENÇO, W. R. 1997b. Description of a new genus and new species of Buthidae scorpion from the Himalayas of India and Nepal with some biogeographic implications. *Entomologische Mitteilungen aus dem Zoologischen Museum Hamburg* 12 (156): 183-188.
- LOURENÇO, W. R. 1998a. Panbiogéographie, les distributions disjointes et le concept de famille relictuelle chez les scorpions. *Biogeographica* 74 (3): 133-144.
- LOURENÇO, W. R. 1998b. Une nouvelle famille est nécessaire pour des microscorpions humicoles de Madagascar et d'Afrique. *Comptes Rendus de l'Académie des Sciences, Paris, Sciences de la Vie* 321: 845-848.
- LOURENÇO, W. R. 1998c. *Uroplectoïdes abyssinicus* new genus and new species of scorpion (Scorpiones, Buthidae) from Ethiopia. *Entomologische Mitteilungen aus dem Zoologischen Museum Hamburg* 12 (158): 309-316.
- LOURENÇO, W. R. (sous presse). Complementary notes on the phylogenetic position of the genus *Birulatus* Vachon, 1973 (Scorpiones, Buthidae) and redescription of *Birulatus haasi*. *Zoology in the Middle East*.
- LOURENÇO, W. R. & VACHON, M. 1995. Un nouveau genre et deux nouvelles espèces de scorpions Buthidae d'Iran. *Bulletin du Muséum national d'Histoire naturelle Paris*, 4e sér. 17 (A3/4): 297-305.
- LOURENÇO, W. R. & VACHON, M. 1997. Un nouveau genre et quatre nouvelles espèces de scorpions Buthidae pour le Moyen-Orient. *Zoosystema* 19 (2-3): 327-336.
- POCOCK, R. I. 1895. On the Arachnida and Myriopoda obtained by Dr. Anderson's Collector during Mr. T. Bent's Expedition to the Hadramaut, South Arabia; with a supplement upon the Scorpions obtained by Dr. Anderson in Egypt and Eastern Soudan. *The Linnean Society's Journal-Zoology* 25: 292-316.
- SIMON, E. 1910. Révision des Scorpions d'Egypte. *Bulletin de la Société entomologique d'Egypte, Cairo*: 57-87.
- SISSOM, W. D. 1990. Systematics, Biogeography, and Paleontology (pp. 64-160). In: POLIS, G. A. (ed.). *The Biology of Scorpions*. Stanford University Press.
- VACHON, M. 1952. Etudes sur les scorpions. *Publications de l'Institut Pasteur d'Algérie, Alger*: 482 pp.
- VACHON, M. 1963. De l'utilité, en systématique, d'une nomenclature des dents des chélicères chez les Scorpions. *Bulletin du Muséum d'Histoire naturelle, Paris*, 2e sér. 35(2): 161-166.
- VACHON, M. 1973. Etude des caractères utilisés pour classer les familles et les genres de Scorpions (Arachnides). 1. La trichobothriotaxie en arachnologie. Sigles trichobothriaux et types de trichobothriotaxie chez les Scorpions. *Bulletin du Muséum national d'Histoire naturelle, Paris*, 3e sér., n° 140, Zool. 104: 857-958.
- VACHON, M. 1975. Sur l'utilisation de la trichobothriotaxie du bras des pédipalpes des Scorpions (Arachnides) dans le classement des genres de la famille des Buthidae Simon. *Comptes Rendus des Séances de l'Académie des Sciences, Paris*, sér. D, 281: 1597-1599.



## Nuovi Anillina (Coleoptera, Carabidae: Bembidiini) del Kenya

Roberta GARETTO<sup>1</sup> & Pier Mauro GIACHINO<sup>2</sup>

<sup>1</sup> Via Milano 13, I-10122 Torino, Italia.

<sup>2</sup> Museo Regionale di Scienze Naturali, Via Giolitti 36, I-10123 Torino, Italia.

**New species of Anillina (Coleoptera, Carabidae: Bembidiini) from Kenya.** - Three new species of Anillina are described from Kenya: *Microdipnites mahnerti* n. sp. from Kirimiri forest (Embu district), *Microdipnites perreti* n. sp. from Taita Hills (near Kwale) and *Selenodipnus embuanus* n. sp. from Irangi forest (Embu district). The zoogeographical interest of these new taxa is stressed.

**Key-words:** Coleoptera - Carabidae - Bembidiini - Anillina - new species - Kenya.

Lo studio di una piccola serie di Carabidae Anillina provenienti dalle raccolte effettuate dal personale del Muséum d'Histoire Naturelle de Genève nell'Africa orientale (Kenya) e gentilmente concessa in studio ad uno degli Autori (P.M.G.) dal Dr. Ivan Löbl, Conservatore del Dipartimento di Entomologia dello stesso Museo, ha permesso l'identificazione di tre specie nuove per la scienza.

Le nuove specie, appartenenti ai generi *Microdipnites* Jeannel, 1957 e *Selenodipnus* Jeannel, 1963, costituiscono oggetto di descrizione nella presente nota.

### **Microdipnites mahnerti** n. sp.

Figg. 1-5

Holotipo ♂ Kenya, Embu district, Kirimiri forest, east of Runyenje, 1550 m, thifting of forest litter, 13.X.77, V. Mahnert et J.-L. Perret leg. (Muséum d'histoire naturelle, Genève).

Paratipi: 2 ♂, 9 ♀, idem (Muséum d'histoire naturelle, Genève; Museo Regionale di Scienze Naturali, Torino; Coll. Giachino, Torino; Coll. Casale, Torino).

DIAGNOSI. Un *Microdipnites* con caratteri perfettamente conformi alla definizione del genere fornita da JEANNEL (1937, 1963): dente labiale assente, un solo articolo dei protarsi dilatato e profondamente asimmetrico nel ♂, elitre profondamente smarginate all'apice, serie ombelicata di tipo C (sensu JEANNEL 1963); edeago non arcuato, privo di restringimento basale, parameri armati di due setole apicali.

*M. mahnerti* n. sp. differisce invece dalle due specie note del genere *M. kahuzianus* (Basilewsky, 1957) e *M. minutissimus* (Basilewsky, 1957), oltre che per la conformazione edeagica, anche per la conformazione della smarginatura dell'apice elitrale, che si presenta molto più accentuata, e per la posizione del 7° poro della serie

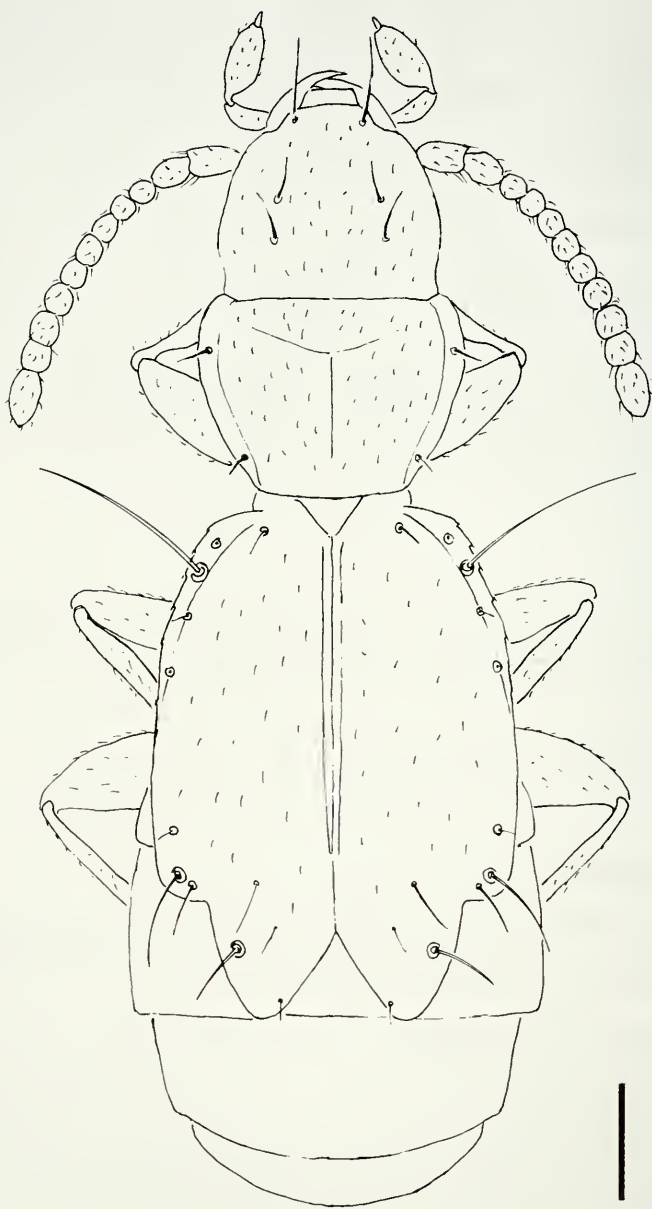
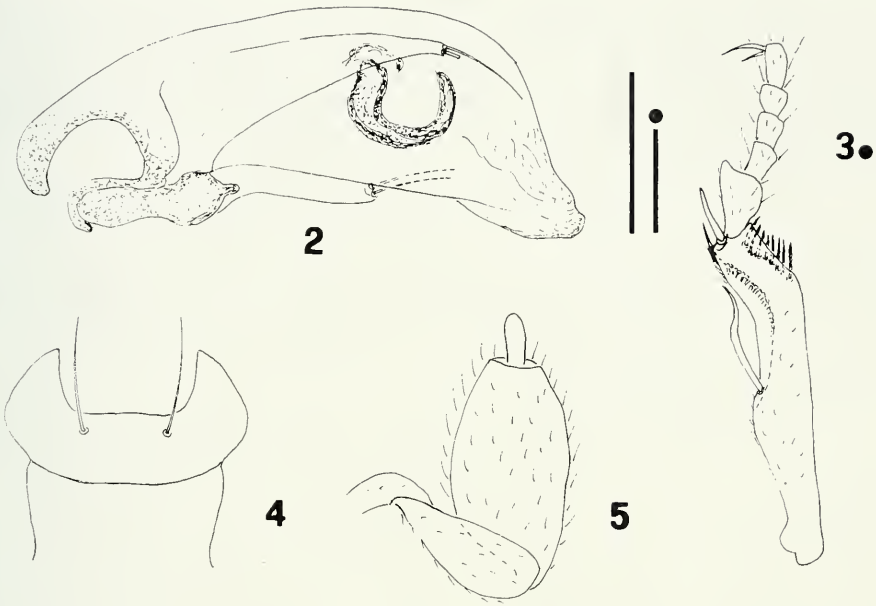

FIG. 1

*Microdipnites mahnerti* n. sp. Holotipo ♂. Habitus. Scala: 0.1 mm.



FIGG. 2-5

*Microdipnites mahnerti* n. sp.: Holotipo ♂ edeago in visione dorsale (2); Paratipo ♂ zampa protoracica destra in visione dorsale (3); Paratipo ♂ labium in visione ventrale (4); Paratipo ♂ palpo labiale sinistro in visione ventrale (5). Scala: 0.05 mm.

ombelicata. Da *M. perreti* n. sp., descritto oltre nella presente nota e il cui maschio è sconosciuto, differisce per la smarginatura apicale delle elitre nettamente più accentuata.

DESCRIZIONE. Lunghezza totale (dall'apice delle mandibole all'apice delle elitre) mm 0.83 - 0.92 (dall'apice delle mandibole all'apice dell'ultimo urotergite mm 1.01-1.14). Corpo poco allungato e relativamente tozzo, depigmentato, fulvo-testaceo con elitre e addome più chiari, giallo-testacei; tegumenti lucidi, a microscultura quasi totalmente svanita, cosparsi di pubescenza rada e breve (fig. 1).

Capo robusto, quasi ipertrofico, più stretto del pronoto, anoftalmo. Antenne ispessite, nettamente moniliformi a partire dal terzo antennomero, raggiungenti, distese all'indietro, la base delle elitre. Solco clipeo-frontale indistinto; margine anteriore dell'epistoma subrettilineo. Due setole sopraorbitali per lato, abbastanza distanziate fraloro e poste su linee parallele, non convergenti all'indietro. Mandibole brevi, semplici, senza creste dorsali; labbro provvisto di 6 setole marginali anteriori; labium stretto, articolato, inerme sul margine anteriore, con epilobi molto sviluppati (fig. 4). Palpi mascellari (fig. 5) con penultimo articolo grande, ovoidale allungato, e ultimo piccolissimo, poco differenziato.

Pronoto trasverso (rapporto larghezza max./ lunghezza max. = 1.38 - 1.42), allargato in avanti, ristretto alla base, con lati lungamente arcuati, non sinuati avanti la

base; non denticolati, né smarginati anteriormente agli angoli posteriori. Angoli anteriori arrotondati, ma prominenti; posteriori ottusi e smussati al vertice. Disco appena convesso, con pubescenza corta e rada; doccia mediana molto superficiale, appena accennata. Doccia marginale larga e spianata, bruscamente ristretta presso la base; setole marginali anteriori inserite all'interno della doccia marginale, circa all'altezza del quarto anteriore; setole basali nettamente avanti agli angoli posteriori.

Elitre brevi, tozze, profondamente smarginate nella zona preapicale, senza traccia di strie (esclusa la stria suturale). Disco poco convesso; tegumenti lucidi, con microscultura quasi indistinta e con pubescenza corta, molto rada ed eretta. Omeri poco indicati, arrotondati; margine post-omerale denticolato, con crenellatura molto fine ma distinta fino all'altezza del 3° poro omerale; smarginatura preapicale profonda, angolosa; apici subtriangolari, separatamente arrotondati. Doccia marginale larga ed evidente nella metà basale.

Chetotassi: poro ombelicato basale grande, foveato, munito di una breve setola. Serie ombelicata di tipo C [i grandi pori setigeri della serie ombelicata corrispondono al 2°, al 6° e al 7° (sensu JEANNEL 1963)]; primi tre pori del gruppo omerale circa equidistanti fra loro, 4° poro leggermente più distanziato e inserito anteriormente alla metà dell'elitra; 5° poro posto circa al terzo apicale dell'elitra, 6° posto presso l'angolo della smarginatura apicale, 7° nettamente preapicale, posto circa alla base del triangolo apicale. Pori discali assenti; piccoli pori setigeri, in numero di due o tre, sono presenti nell'area apicale presso il 6° e 7° poro della serie ombelicata e nell'area immediatamente preapicale.

Zampe (fig. 3) relativamente allungate, non ispessite; tarsi anteriori nei maschi con un solo tarsomero asimmetricamente dilatato.

Edeago (fig. 2) piccolo, poco arcuato; base del lobo mediano profondamente incisa, biloba in visione laterale; margine ventrale del lobo mediano subrettilineo. Apice ingrossato, largamente membranoso, con lama apicale poco evidente e irregolarmente curvata. Sacco interno munito di una lamella copulatrice piccola, poco chitinizzata, fortemente arcuata, quasi a ferro di cavallo, con lato concavo rivolto verso l'alto. Parameri muniti ciascuno di due setole apicali.

DERIVATIO NOMINIS. Dedichiamo con piacere questa nuova specie al Dr. V. Mahnert, Direttore del Muséum d'histoire naturelle de Genève, che per primo la raccolse insieme al Dr. J.-L. Perret.

DISTRIBUZIONE, ECOLOGIA. *Microdipnites mahnerti* n. sp. è noto al momento solo della località tipica: la foresta di Kirimiri a 1550 m di altitudine in Kenya, sito a SE del più noto Monte Kenya. Gli esemplari sono stati raccolti al vaglio in foresta mista.

### **Microdipnites perreti** n. sp.

Figg. 6-10

Holotipo ♀ Kenya, Taita district, Taita Hills, near Wundanyi. 1350 m, thifting in mixed forest, 2.XII.1974, V. Mahnert et J.-L. Perret leg. (Muséum d'histoire naturelle, Genève)

DIAGNOSI. Un *Microdipnites* con caratteri perfettamente conformi alla definizione del genere fornita da JEANNEL (1937, 1963): dente labiale assente, elitre smarginate posteriormente, serie ombelicata di tipo C (sensu JEANNEL 1963).

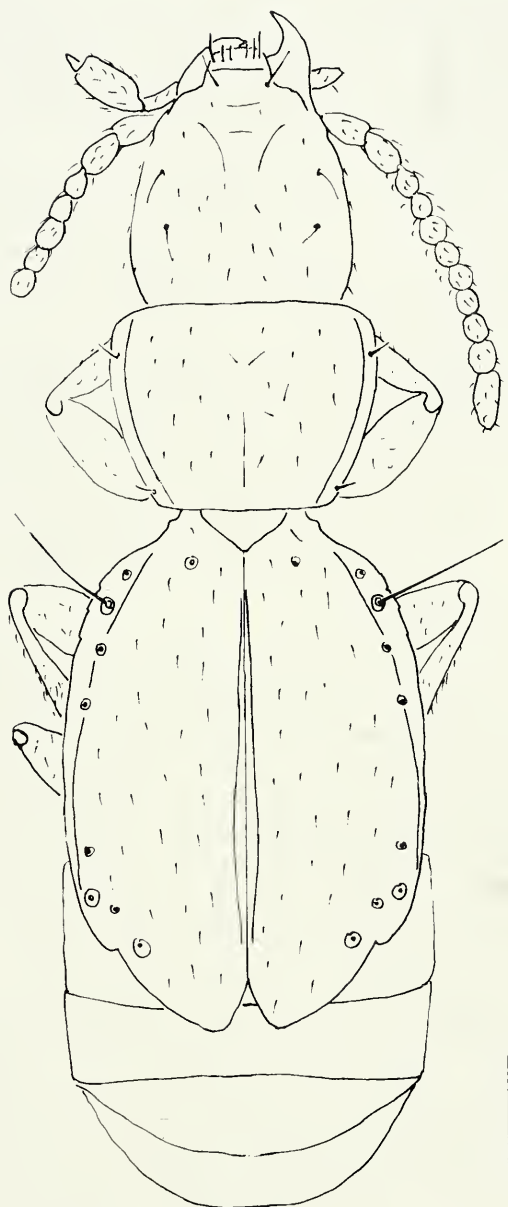

FIG. 6

*Microdipnites perreti* n. sp.: Holotipo ♀. Habitus. Scala: 0.1 mm.

*M. perreti* n. sp. differisce invece da *M. minutissimus* (Basilewsky, 1957) per la smarginatura dell'apice elitrale, che si presenta più accentuata, e per la posizione del 7° poro della serie ombelicata; da *M. mahnerti* n. sp. per la conformazione della smarginatura apicale delle elitre, che si presenta molto meno accentuata e da *M. kahuzianus* (Basilewsky, 1957) per la diversa conformazione dell'apice elitrale e per la differente localizzazione del 6° poro della serie ombelicata.

DESCRIZIONE. Lunghezza totale dell'olotipo ♀ (dall'apice delle mandibole all'apice delle elitre) mm 0.86 (dall'apice delle mandibole all'apice dell'ultimo urotergite mm 1.03). Corpo tozzo, depigmentato, fulvo-testaceo con elitre e addome più chiari, giallo-testacei; tegumenti lucidi, a microscultura quasi totalmente svanita, cosparsi di pubescenza rada e breve (fig. 6).

Capo robusto, appena più stretto del pronoto, anoftalmo. Antenne ispessite, nettamente moniliformi a partire dal terzo antennomero, raggiungenti appena, distese all'indietro, la base del pronoto. Solco clipeo-frontale indistinto; margine anteriore dell'epistoma subrettilineo. Due setole sopraorbitali perlato, abbastanza distanziate fra loro e poste su linee parallele, non convergenti all'indietro. Mandibole brevi, semplici, senza creste dorsali; labbro provvisto di 6 setole marginali anteriori; labium stretto, articolato, privo di dente sul margine anteriore, con epilobi poco sviluppati (fig. 10). Palpi mascellari (fig. 9) con penultimo articolo grande, ovoidale allungato, e ultimo piccolissimo, poco differenziato.

Pronoto trasverso (rapporto larghezza max./lunghezza max. = 1.31), allargato in avanti, ristretto alla base, con lati poco e lungamente arcuati, non sinuati avanti la base, non denticolati né smarginati anteriormente agli angoli posteriori. Angoli anteriori arrotondati, non prominenti; posteriori ottusi e smussati al vertice. Disco appena convesso, con pubescenza corta e rada; doccia mediana molto superficiale, appena accennata. Doccia marginale larga e spianata, non ristretta posteriormente presso la base; setole marginali anteriori inserite all'interno della doccia marginale, circa all'altezza del quarto anteriore; setole basali appena avanti agli angoli posteriori.

Elitre brevi, tozze, smarginate nella zona preapicale, senza traccia di strie (esclusa la stria suturale). Disco poco convesso; tegumenti lucidi, con microscultura quasi indistinta e con pubescenza corta, molto rada ed eretta. Omeri sfuggenti, largamente arrotondati; margine post-omerale impercettibilmente denticolato, con crenellatura estremamente fine e poco distinta fino all'altezza del 3° poro omerale; smarginatura preapicale presente ma poco accentuata; apici elitrali separatamente arrotondati. Doccia marginale larga ed evidente fino al terzo apicale.

Chetotassi: poro ombelicato basale grande, foveato. Serie ombelicata di tipo C (i grandi pori setigeri della serie ombelicata corrispondono al 2°, al 6° e al 7° (sensu JEANNEL 1963)); primi tre pori del gruppo omerale circa equidistanti fra loro, 4° poro leggermente più distanziato e inserito anteriormente alla metà dell'elitra; 5° poro posto circa al terzo apicale dell'elitra, 6° posto prima della smarginatura apicale, 7° posto presso la smarginatura apicale. Pori discali assenti; un piccolo poro setigero è presente nell'area preapicale fra il 6° e il 7° poro della serie ombelicata.

Zampe (fig. 8) relativamente allungate, non ispessite.

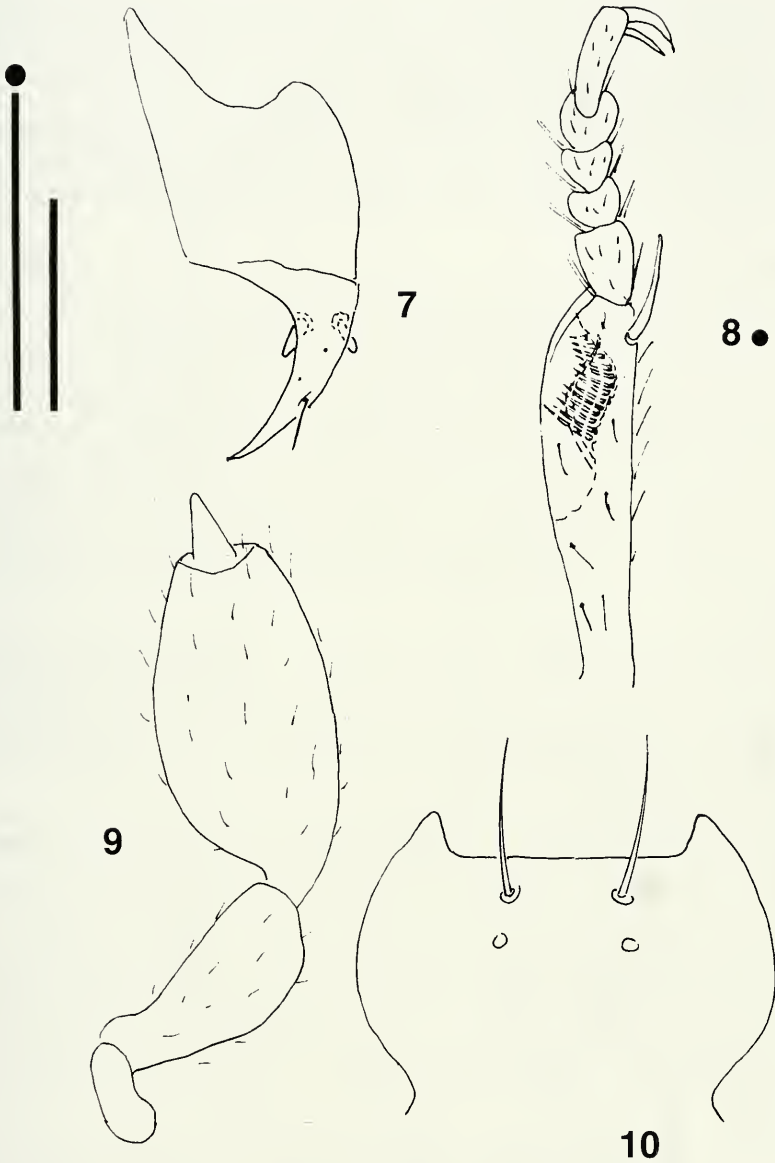

FIGG. 7-10

*Microdipnites perreti* n. sp., Holotipo ♀: stilomeri 1 - 2 sinistri in visione dorsale (7); zampa protoracica destra in visione dorsale (8); palpo labiale sinistro in visione ventrale (9); labium in visione ventrale (10). Scala: 0.1 mm.

Stili, nell'olotipo ♀ (fig. 7), gracili, con fossetta sensoria munita di una setola. Maschio sconosciuto.

DERIVATIO NOMINIS. Dedichiamo con piacere questa nuova specie al Dr. J.-L. Perret che per primo la raccolse insieme al Dr. V. Mahnert.

DISTRIBUZIONE, ECOLOGIA. *Microdipnites perreti* n. sp. è noto al momento solo della località tipica: Taita Hills, presso Kwale a SW di Mombasa (Kenya). L'unico esemplare noto è stato raccolto al vaglio in foresta mista ad una quota di 1350 m.

### **Selenodipnus embuanus** n. sp.

Figg. 11-15

Holotipo ♀ Kenya. Embu district, Irangi Forest Station, 2100 m, thifting of forest litter, 12.X.1977. V. Mahnert et J.-L. Perret leg. (Muséum d'histoire naturelle, Genève)

DIAGNOSI. Un *Selenodipnus* con caratteri perfettamente conformi alla definizione del genere fornita da JEANNEL (1937, 1963): dente labiale assente, setole pronotali presenti in numero di due, elitre non smarginate posteriormente, serie ombelicata di tipo B (sensu JEANNEL 1963), setole discali presenti, bordo omerale denticolato.

*S. embuanus* n. sp. differisce invece da *S. parallelus* (Jeannel, 1957) per le elitre di forma ovoidale, a lati non paralleli, e per la posizione del 7° poro della serie ombelicata; da *S. humerosus* (Jeannel, 1957) per l'apice elitrale non allargato, ma regolarmente arrotondato e per la differente localizzazione del 7° e 8° poro della serie ombelicata.

DESCRIZIONE. Lunghezza totale dell'olotipo ♀ (dall'apice delle mandibole all'apice delle elitre) mm 1.23 (dall'apice delle mandibole all'apice dell'ultimo urotergite mm 1.27). Corpo tozzo, depigmentato, fulvo-testaceo con elitre e addome più chiari, giallo-testacei; tegumenti lucidi, a microscultura quasi totalmente svanita, cosparsi di pubescenza rada e breve (fig. 11).

Capo robusto, più stretto del pronoto, anoftalmo. Antenne ispessite, nettamente moniliformi a partire dal terzo antennomero, raggiungenti appena, distese all'indietro, la base del pronoto. Solco clipeo-frontale indistinto; margine anteriore dell'epistoma subrettilineo. Due setole supraorbitali per lato, abbastanza distanziate fra loro e poste su linee convergenti posteriormente, due setole occipitali presenti. Mandibole brevi, semplici, senza creste dorsali; labbro grande, provvisto di 6 setole marginali anteriori; labium stretto, trasverso, articolato, privo di dente sul margine anteriore, con epilobi grandi ma moderatamente sporgenti (fig. 15). Palpi mascellari (fig. 14) con penultimo articolo poco rigonfio, ovoidale molto allungato, e ultimo lungo circa un terzo del penultimo.

Pronoto subquadrato (rapporto larghezza max./lunghezza max. = 1.17), poco allargato in avanti, moderatamente ristretto alla base, con lati poco arcuati, quasi rettilinei e convergenti nella metà basale; non sinuati ma distintamente denticolati avanti la base. Angoli anteriori poco prominenti, posteriori retti al vertice. Disco appena convesso, con pubescenza corta e rada; doccia mediana molto superficiale, appena accennata. Doccia marginale larga e spianata, non raggiungente la base e non ristretta posteriormente; setole marginali anteriori inserite all'interno della doccia marginale, circa all'altezza del quarto anteriore; setole basali appena avanti agli angoli posteriori.



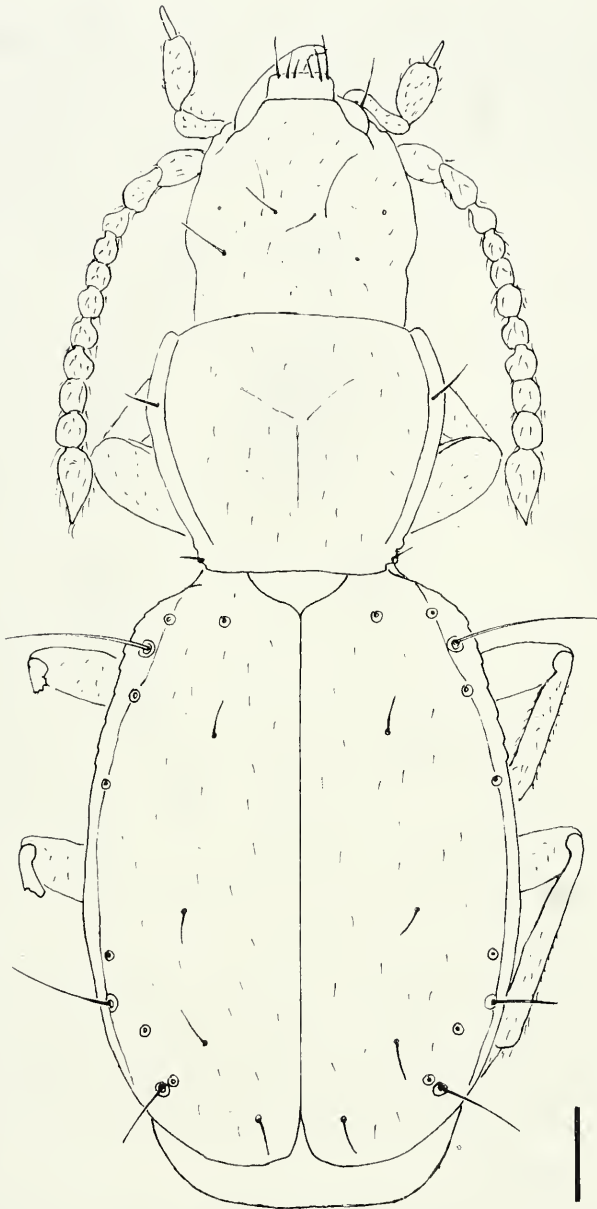
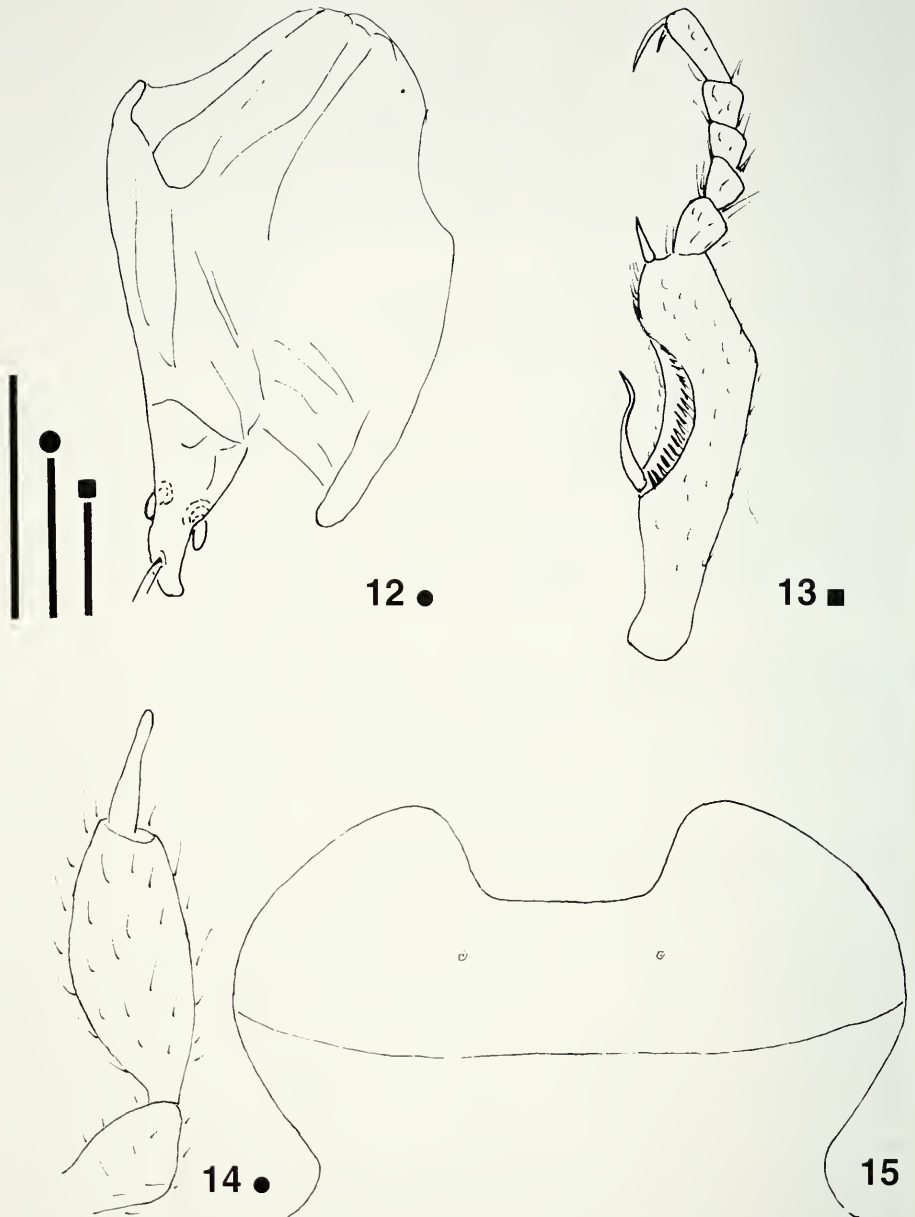

FIG. 11

*Selenodipnus embuanus* n. sp.: Holotipo ♀. Habitus. Scala: 0.1 mm.



FIGG. 12-15

*Selenodipnus embuanus* n. sp., Holotipo ♀: stilomeri 1 - 2 destri in visione dorsale (12); zampa protoracica destra in visione dorsale (13); palpo labiale sinistro in visione ventrale (14); labium in visione ventrale (15). Scala: 0.05 mm.

Elitre brevi, tozze e largamente ovoidali; senza traccia di strie. Disco poco convesso; tegumenti lucidi, con microscultura quasi indistinta e con pubescenza corta, molto rada ed eretta. Omeri appena accennati, largamente arrotondati; margine post-omerale sensibilmente denticolato, con crenellatura fine ma distinta fino all'altezza del 4° poro omerale; apici elitrali separatamente e largamente arrotondati, privi di smarginatura preapicale. Doccia marginale larga ed evidente fino al livello del 9° poro della serie ombelicata.

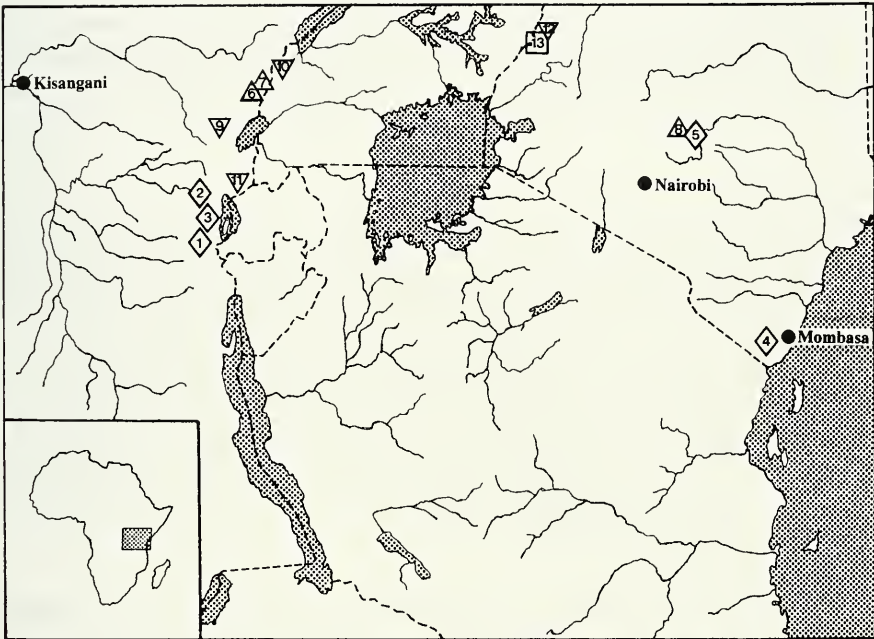

FIG. 16

Cartina di distribuzione dei generi e specie di Anillina nell'Africa centro-orientale.  $\diamond$  *Microdipnites* Jeannel, 1957: *M. kauzianus* (Basilewsky, 1951) (1); *M. minutissimus* (Basilewsky, 1954) (2); *M. vanschuytbroeckii* Bruneau De Miré, 1990 (3); *M. perreti* n. sp. (4); *M. mahnerti* n. sp. (5).  $\Delta$  *Selenodipnus* Jeannel, 1963: *S. humerosus* Jeannel, 1957 (6); *S. parallelus* Jeannel, 1957 (7); *S. embuanus* n. sp. (8).  $\nabla$  *Pelonomites* Jeannel, 1963: *P. leleupi* (Basilewsky, 1953) (9); *P. celisi* (Basilewsky, 1954) (10); *P. coiffaiti* Bruneau De Miré, 1990 (11); *P. vignai* Zaballo & Casale, 1997 (12).  $\square$  *Elgonotyphlus* Sciaky & Zaballo, 1993: *E. zoiai* Sciaky & Zaballo, 1993 (13).

Chetotassi: poro ombelicato basale grande, foveato. Serie ombelicata di tipo B [i grandi pori setigeri della serie ombelicata corrispondono al 2°, al 6° e al 9° (sensu JEANNEL 1963)]; primi tre pori del gruppo omerale circa equidistanti fra loro, 4° poro distanziato di circa il doppio e inserito anteriormente alla metà dell'elitra; 5° poro posto prima del terzo apicale dell'elitra, 6° posto al terzo apicale dell'elitra, 7° circa equidistante e posto all'interno sul disco; 8° e 9° estremamente ravvicinati fra loro. Pori

discali presenti in numero di tre; un piccolo poro setigero è pure presente nell'area preapicale dopo il 9° poro della serie ombelicata.

Zampe (fig. 13) relativamente allungate, non ispessite.

Stili, nell'olotipo ♀ (fig. 12), robusti, muniti di due setole spiniformi e di una fossetta sensoria con due setole.

Maschio sconosciuto.

DERIVATIO NOMINIS. La nuova specie prende nome dal distretto dell'Embu, posto a Sud del Monte Kenya, dove è sita la località tipica.

DISTRIBUZIONE, ECOLOGIA. *Selenodipnus embuanus* n. sp. è noto al momento solo della località tipica: Irangi Forest, sita a 2100 m di quota sulle propaggini meridionali del Monte Kenya (distretto di Embu). L'unico esemplare conosciuto è stato raccolto vagliando il terriccio posto sotto alberi morti in foresta mista.

#### CONSIDERAZIONI ZOOGEOGRAFICHE

Le nuove specie descritte nella presente nota rivestono un particolare significato zoogeografico. Del Kenya erano finora note due specie di Anillina: *Pelonomites vignai* Zaballos & Casale, 1997 e *Elgonotyphlus zoiai* Sciaky & Zaballos, 1993, ambedue del Monte Elgon. La scoperta di specie appartenenti ai generi *Microdipmites* Jeannel, 1957 e *Selenodipnus* Jeannel, 1963 in Kenya, in zone relativamente lontane dagli areali finora conosciuti per questi due generi (essenzialmente la catena montuosa del Kiwu in Congo) appare quindi di grande interesse, e conferma uno scenario di popolamento (fig. 16), per alcuni generi della linea filetica di *Microtyphlus* (*Microdipmites*, *Pelonomites*, *Selenodipnus*, *Elgonotyphlus*), ampiamente illustrato e discusso da JEANNEL (1961), LELEUP (1965) e ZABALLOS & CASALE (1997).

#### RINGRAZIAMENTI

Siamo molto grati al Dr. Ivan Löbl del Muséum d'histoire naturelle di Ginevra per averci concesso in studio i preziosi materiali oggetto della presente nota. Un ringraziamento particolare va al Prof. Achille Casale del Dipartimento di Zoologia e Antropologia Biologica dell'Università di Sassari per la revisione critica del manoscritto.

#### BIBLIOGRAFIA

- JEANNEL, R. 1937. Les Bembidiides endogés (Col. Carabidae). *Revue française d'Entomologie* 3: 241-339.
- JEANNEL, R. 1961. La Gondwanie et le peuplement de l'Afrique. *Annales du Musée royal du Congo Belge* 102: 5-161.
- JEANNEL, R. 1963. Monographie des "Anillini". Bembidiides endogés (Coleoptera Trechidae). *Mémoires du Muséum national d'Histoire naturelle, Paris* (A) 28: 33-204.
- LELEUP, N. 1965. La faune entomologique cryptique de l'Afrique intertropicale. *Annales du Musée royal de l'Afrique Centrale, Tervuren* 8, 141: 1-186.
- SCIACKY, R. ZABALLOS, J. P. 1993. *Elgonotyphlus zoiai*: new genus and new species of phanerodont Anillini from Kenya (Coleoptera Carabidae). *Journal of African Zoology* 107: 321-327.
- ZABALLOS, J. P., CASALE, A. 1997. Un nuevo *Pelonomites* Jeannel, 1963 del Monte Elgon (Kenya) (Coleoptera: Carabidae: Bembidiinae: Anillini). *Elytron* 11: 105-113.

***Histiostrongylus spineus* n. sp. (Nematoda: Trichostrongylina), parasite de *Phyllostomus discolor* (Chiroptera: Phyllostomidae) et nouvelles données sur les genres *Histiostrongylus* Molin, 1861 et *Parahistiostrongylus* Perez Vigueras, 1941**

Claude VAUCHER<sup>1</sup> & Marie-Claude DURETTE-DESSET<sup>2</sup>

<sup>1</sup>Muséum d'histoire naturelle, case postale 6434, CH-1211 Genève 6, Suisse.

<sup>2</sup>Muséum national d'Histoire naturelle, Laboratoire de Biologie parasitaire: Protozoologie, Helminthologie, associé au CNRS, 61, rue de Buffon, F-75231 Paris cedex 05, France.

***Histiostrongylus spineus* n. sp. (Nematoda: Trichostrongylina), parasite of *Phyllostomus discolor* (Chiroptera: Phyllostomidae), and comments on the genera *Histiostrongylus* Molin, 1861 and *Parahistiostrongylus* Perez Vigueras, 1941.** - *Histiostrongylus spineus* n. sp. is described from the bat *Phyllostomus discolor* caught in Peru and in Nicaragua. *Parahistiostrongylus octacanthus* Lent & Freitas, 1940 is redescribed. *H. spineus* is distinguished from the other species of the genus, *H. coronatus* Molin, 1861 mainly by the disposition of the bursal rays 6 and 8, the dorsal ray and the oesophagus. The validity of both genera is confirmed.

**Key-words:** Nematoda - Molineoidea - Molineidae - Anoplostrongylinae - *Histiostrongylus* - *Parahistiostrongylus* - neotropical bats.

## INTRODUCTION

Parmi les Anoplostrongylinae (Molineidae) parasites de Chiroptères, plusieurs genres sont caractérisés par des têtes armées d'épines. Nous terminons dans ce travail la révision des espèces du Nouveau Monde commencée précédemment (VAUCHER & DURETTE-DESSET 1986).

## MATÉRIEL

Le matériel a été collecté au Nicaragua par A. de Chambrier et T. Jaccoud (Muséum de Genève), au Pérou par C. Vaucher, au Paraguay par C. Dlouhy (Asuncion) ou lors des missions du Muséum de Genève (EMGP). D'autres exemplaires résultent de la dissection de Chiroptères provenant du Surinam et de Colombie, conservés au Département de mammalogie du Muséum de Genève. Les parasites sont déposés dans les collections du Muséum de Genève (INVE) et du Muséum de Paris (MNHN, KP).

**Histiostrongylus spineus** n. sp.

## MATÉRIEL-TYPE

Chez *Phyllostomus discolor* (intestin grêle): Pérou, prov. Loreto, Samiria, mâle holotype (25150 INVE), femelle allotype (25151 INVE) et 2 paratypes mâles et 1 paratype femelle (25152 INVE), 25.10.1980, leg. C. Vaucher et F. Bona.

## AUTRE MATÉRIEL

Chez *Phyllostomus discolor*: Pérou, prov. Loreto, Rio Yanayacu, 1 femelle (MNHN, 844 KP), 20.10.1980; Pérou, prov. Loreto, Cocha Yuracyacu, 1 fragment (25153 INVE), 20.10.1980, leg. C. Vaucher et F. Bona; Nicaragua, Prov. Leon, rives du lac Momotombo, 1 mâle (25154 INVE), 20.01.1983, leg. A. de Chambrier et T. Jaccoud.

Nématodes de taille moyenne, non enroulés. Synlophe constitué d'environ 89 (mâle) à 105 crêtes (femelle) au milieu du corps, orientées perpendiculairement à sa paroi, à peine plus serrées sur les faces latérales que sur les faces médianes (Fig. 3). Musculature présentant une portion non contractile très développée. Tête portant un capuchon céphalique armé de 8 grosses épines réunies à leur base, à lame acérée (Figs 1, 4). Vue apicale montrant une bouche triangulaire avec une minuscule dent dorsale incisée. Cycle de papilles labiales internes et cycle de papilles labiales externes réduits aux deux latérales, réunies en une papille double voisine des amphides. Quatre papilles céphaliques (Fig. 4). Anneau nerveux, pore excréteur et deirides très antérieurs et situés au même niveau (Figs 1, 2). Glandes excrétrices de grande taille. Oesophage pourvu d'une valvule, précédant une constriction délimitant un bulbe distal distinct. Présence d'un court canal oesophago-intestinal (Fig. 1).

Mâle: mâle holotype long de 8.1 mm sur 175  $\mu$ m de large. Tête haute de 155  $\mu$ m et de 240  $\mu$ m de diamètre, épines incluses. Anneau nerveux, pore excréteur et deirides situés respectivement à 235, 280 et 290  $\mu$ m de l'apex. Oesophage long de 570  $\mu$ m. Bourse caudale de type 2-3 mesurant 295 x 175  $\mu$ m, relativement petite, aux côtes 4 plus courtes que les côtes 3 et 5. Papilles des côtes 6 situées environ à mi-distance des côtes 5 et 8. Côtes 8 naissant au 1/3 de la côte dorsale, longues, mais n'atteignant pas le bord de la membrane bursale. Côte dorsale divisée en 3 branches à son extrémité distale, les deux branches externes elles-mêmes subdivisées (Figs 5-7). Spicules très longs, subégaux, de 1.5 mm (19% de la longueur du corps) pourvus d'une double aile, élargie surtout dans sa portion proximale; extrémité distale divisée en trois branches, l'externo-latérale se séparant nettement de l'interno-dorsale et de l'interno-ventrale; branches internes renflées à leur extrémité, l'interno-ventrale étant caractérisée par sa forme en pince (Fig. 8). A l'extrémité de chaque branche, présence de membranes, collapsées par la fixation.

## FIGS 1-8

*Histiostrongylus spineus* n. sp. chez *Phyllostomus discolor*. 1 - femelle, partie antérieure, vue latérale droite (la flèche indique l'emplacement de la deiride); 2 - paratype, deiride; 3 - paratype mâle, coupe transversale au milieu du corps; 4 - vue apicale d'un fragment antérieur; 5 - mâle, bourse caudale, vue latérale droite; 6 - premier paratype mâle, détail de la côte dorsale, vue ventrale; 7 - second paratype mâle, bourse caudale, vue ventrale; 8 - premier paratype mâle, détail de l'extrémité du spicule droit disséqué; el = branche externo-latérale; id = branche interno-dorsale; iv = branche interno-ventrale. (1: MNHN, 844 KP; 2, 3, 6-8: 25152 INVE; 4: 25153 INVE; 5: 25154 INVE).

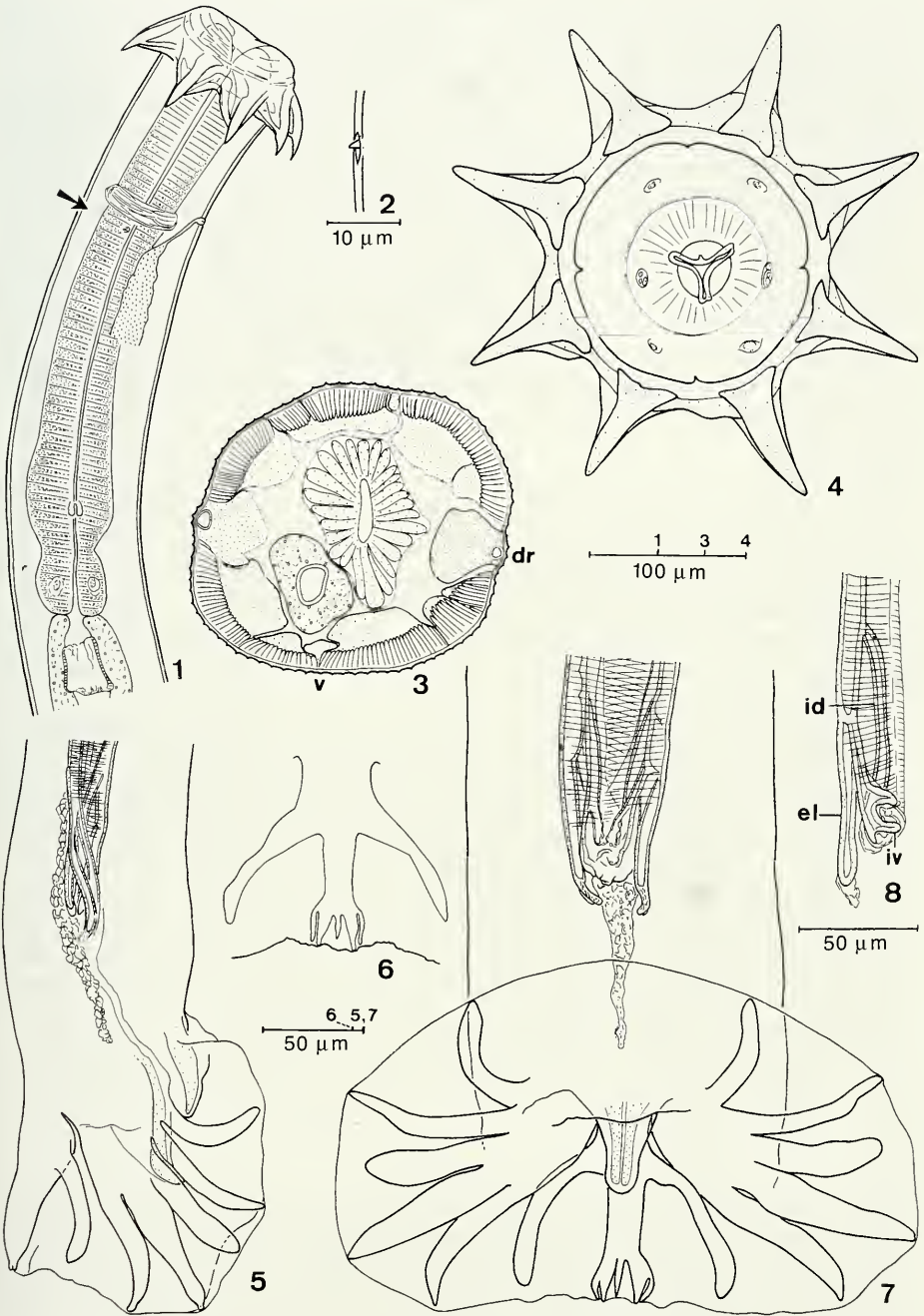

Cône génital avec lèvre dorsale longue, lèvre ventrale élargie et peu proéminente. Papilles 0 non observées, papilles 7 filiformes. Gubernaculum très visible, d'aspect spongieux, long de 150  $\mu\text{m}$  (Fig. 7).

Femelle: allotype longue de 9.5 mm sur 170  $\mu\text{m}$ , adulte mais non ovigère. Tête haute de 160  $\mu\text{m}$  et de 245  $\mu\text{m}$  de diamètre, épines incluses. Oesophage long de 695  $\mu\text{m}$ . Anneau nerveux, pore excréteur et deirides situés respectivement à 190, 183 et 202  $\mu\text{m}$  de l'apex. Vulve à 2.8 mm de l'extrémité postérieure (70% de la longueur totale). Ovéjecteur amphidelphe (les deux femelles du matériel-type) ou opisthodelphe (1 spécimen), présentant toujours une très forte asymétrie du vestibule (Fig. 18); branche antérieure: vestibule 810  $\mu\text{m}$ , sphincter 60  $\mu\text{m}$  et trompe 175  $\mu\text{m}$ ; branche postérieure: vestibule 80  $\mu\text{m}$ , sphincter 60  $\mu\text{m}$  et trompe 180  $\mu\text{m}$ . Utérus ne contenant pas d'oeufs (de même que chez les deux autres femelles). Queue longue de 90  $\mu\text{m}$ , avec deux pointes latéro-ventrales et une dorsale dédoublée entourant une pointe médiane acérée (Figs 19, 22).

#### REMARQUES

L'espèce que nous avons décrite ci-dessus possède les caractéristiques du genre *Histiostromylus* Molin, 1861 décrit chez *Phyllostomus discolor* au Brésil et particulièrement bien illustré par PEREZ VIGUERAS (1941) et BARUS & VALLE (1967). Ces caractéristiques sont les suivantes: ovéjecteur fortement asymétrique, spicules très longs (plus de 1 mm), se divisant en trois branches à leur extrémité distale et présence d'un gubernaculum. De plus, elle possède comme *H. coronatus* Molin, 1861, une valvule oesophago-intestinale.

Cependant, plusieurs caractères la distinguent de *H. coronatus*, espèce-type du genre: alors que chez celle-ci, les côtes 6 et 8 sont parallèles et que leurs extrémités sont très rapprochées, chez *H. spineus* n. sp. au contraire, ces côtes sont divergentes et leurs extrémités écartées d'une distance environ égale à celle qui sépare les extrémités des côtes 5 et 6. L'oesophage est différent également, l'espèce-type ne possédant pas de bulbe proximal comparable. D'autre part, dans notre matériel, la côte dorsale ne se termine pas par une pointe dépassant très nettement les côtes 9 et 10, comme c'est le cas chez *H. coronatus* (Perez Viguera 1941; Barus & Valle 1967). Enfin, les épines céphaliques sont plus robustes, d'aspect triangulaire, épaisses à la base et présentent une petite indentation distale qui n'existe pas chez l'espèce-type.

Étymologie: *spineus*, adjectif latin signifiant épineux.

#### FIGS 9-17

*Parahistiostromylus octacanthus* Lent & Freitas, 1940 chez *Phyllostomus elongatus*. 9 - femelle, extrémité antérieure (la flèche indique l'emplacement de la deiride); 10 - femelle, coupe transversale au milieu du corps; 11 - femelle, vue apicale; 12 - 14: variations de la bourse caudale selon la provenance: 12, matériel colombien; 13 - matériel paraguayen; 14 - vue latérale droite, matériel péruvien; 15 - variation de l'extrémité de la côte dorsale; 16 - mâle, détail de l'extrémité d'un spicule droit disséqué, vues ventrale, dorsale, latérale; 17 - deiride. (9 - 11, 14, 17: 25174 INVE; 12: 25160 INVE; 13, 15, 16: 25156 INVE).



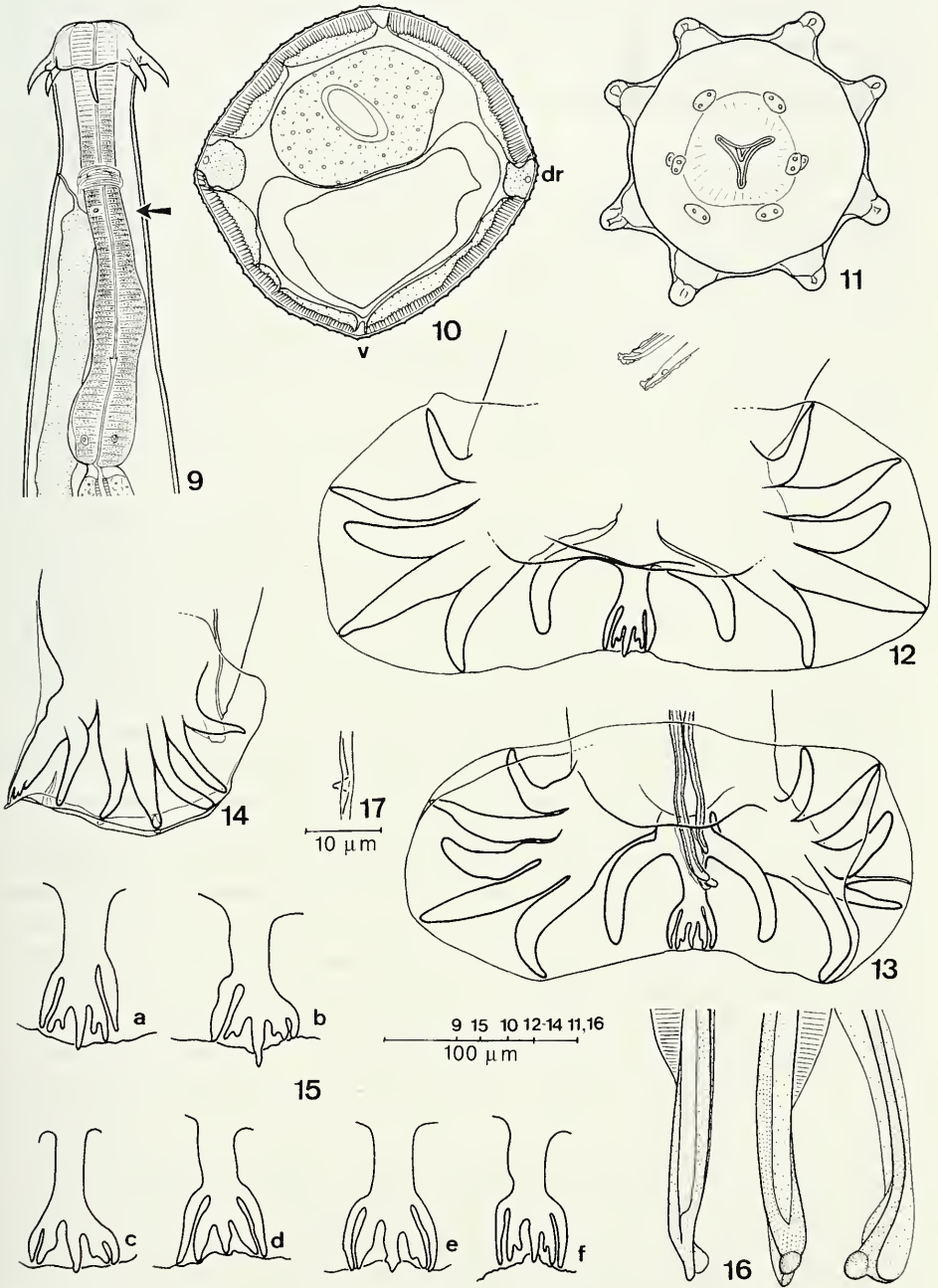

Bien que le nombre de spécimens examinés soit réduit, les prévalences semblent élevées: 3 *P. discolor* parasités sur 5 examinés provenant du Pérou; 1 parasité sur 1 examiné provenant du Nicaragua.

### **Parahistiostrongylus octacanthus** Lent & Freitas, 1940

#### MATÉRIEL ÉTUDIÉ

Chez *Phyllostomus hastatus*: Pérou, prov. Loreto, Rio Yanayacu, 1 mâle, 1 partie antérieure (25155 INVE), 18.10.1980, leg. C. Vaucher et F. Bona; Paraguay, prov. Concepcion, 20 km au sud de l'estancia "Estrellas", 6 mâles, 11 femelles, 3 fragments antérieurs (25156 INVE; MNHN, 202 KP), 16.10.1979, leg. EMGP; Brésil, prov. Rio de Janeiro, estancia "Belfa", Vale do Saõ Joaõ, 2 mâles, 1 femelle (25157 INVE), 10.01.1986, leg. C. Dlouhy; Colombie, 24 mâles et 23 femelles chez 14 hôtes (25158-25171 INVE; MNHN, 842, 843 KP), 1961-1965, leg. B. Mechler; Surinam, 3 mâles et 7 femelles, chez 2 hôtes (25172, 25173 INVE).

Chez *P. elongatus*: Pérou, prov. Loreto, Samiria, 4 mâles, 8 femelles (25174 INVE), 25.10.80; 2 fragments antérieurs, 1 femelle (25175 INVE), 08.11.1980; 2 femelles (25176 INVE), 08.10.1980, leg. C. Vaucher et F. Bona.

Chez *Stumira lilium*: Paraguay, prov. Itapua, Caicisa, 1 mâle, 1 femelle (25177 INVE), 06.11.1982; 1 femelle (25178 INVE), 07.11.1982; 1 femelle, 1 partie antérieure (25179 INVE), 07.11.1982, leg. EMGP.

Nématodes de taille moyenne, non enroulés. Synlophe constitué de petites crêtes à peine plus serrées sur les faces latérales que sur les faces médianes, orientées perpendiculairement à la paroi du corps (Fig. 10). Chez un mâle (25156 INVE), il y a 81 crêtes au milieu du corps; chez deux femelles (25158 INVE), 81 à 83 crêtes au niveau de la fin de l'oesophage, 86 à 91 au quart antérieur du corps, 88 à 91 au tiers antérieur, 88 et 87 au milieu, 74 et 71 au quart postérieur; chez une autre (25174 INVE), 96 crêtes au milieu du corps. Musculature circulaire présentant une nette portion contractile. Tête avec une vésicule céphalique armée de 8 grosses épines en forme de lame mince et acérée, réunies à leur base (Fig. 9). Vue apicale montrant une bouche triangulaire pourvue d'une dent dorsale. Cycle de papilles labiales internes réduit aux deux latérales; cycle complet de papilles labiales externes. Papilles labiales interno- et externo-latérales formant deux papilles doubles associées aux amphides; autres papilles labiales externes formant quatre papilles doubles avec les quatre papilles céphaliques (Fig. 11). Anneau nerveux, pore excréteur et deirides très antérieurs, situés au même niveau. Oesophage présentant un élargissement médian et un bulbe terminal, pourvu d'une discrète valvule au niveau de la constriction postérieure. Présence d'un très court canal oesophago-intestinal (Fig. 9).

Mâle: un mâle de 5.6 mm a 220 µm de diamètre. Tête haute de 112 µm et de 218 µm de diamètre, épines incluses. Anneau nerveux, pore excréteur et deirides situés respectivement à 230, 250 et 250 µm de l'apex. Oesophage long de 610 µm. Bourse caudale de type 2-3, mesurant 385 x 155 µm (Figs 12-14). Côtes 4 plus courtes que les côtes adjacentes. Côtes 6 écartées des côtes 5. Espace entre les côtes 6 et 8 un peu plus court que l'espace entre les côtes 5 et 6. Cône génital avec des lèvres dorsale et ventrale élargies. Côtes 8 naissant au tiers proximal de la hauteur de la côte dorsale, plus courtes que celle-ci et n'atteignant pas le bord de la membrane bursale. Côte dorsale divisée de façon variable à son extrémité distale: côtes 9 et 10 naissant au tiers distal de la côte dorsale, parfois séparées à la base, parfois portées par un court tronc commun (Fig. 15).

Côtes 10 portant un appendice interne plus ou moins développé. Côtes 11 fusionnées en une pointe acérée dépassant souvent le lobe dorsal de la membrane. Spicules courts, de 255  $\mu\text{m}$  (230-285  $\mu\text{m}$  chez 6 autres individus). Extrémité distale des spicules recourbée dorsalement et terminée par une boule arrondie; du côté ventral au contraire, le spicule est aplati et forme une palette élargie (Fig. 16). Pas de papilles observables au niveau du cône génital. Gubernaculum absent.

Femelle: une femelle longue de 7.3 mm a un diamètre de 215  $\mu\text{m}$  au milieu du corps. Tête haute de 110  $\mu\text{m}$  et de 160  $\mu\text{m}$  de diamètre, épines incluses. Oesophage long de 610  $\mu\text{m}$ . Anneau nerveux, pore excréteur et deirides situés respectivement à 202, 250 et 265  $\mu\text{m}$  de l'apex. Vulve s'ouvrant à 2.67 mm de l'extrémité postérieure (61% de la longueur du corps). Ovéjecteur amphidelphe, vestibule symétrique ou présentant une légère asymétrie (Fig. 21). Branche antérieure: vestibule 270  $\mu\text{m}$ , sphincter 155  $\mu\text{m}$  et trompe 350  $\mu\text{m}$ ; branche postérieure: vestibule 350  $\mu\text{m}$ , sphincter 155  $\mu\text{m}$  et trompe 570  $\mu\text{m}$ . Les dimensions des différentes parties de l'ovéjecteur présentent une variabilité marquée; chez la femelle dont l'ovéjecteur est illustré (Fig. 21), les dimensions suivantes ont été relevées: Branche antérieure: vestibule 135  $\mu\text{m}$ , sphincter 100  $\mu\text{m}$  et trompe 290  $\mu\text{m}$ ; branche postérieure: vestibule 130  $\mu\text{m}$ , sphincter 100  $\mu\text{m}$  et trompe 190  $\mu\text{m}$ . Utérus antérieur long de 1.9 mm avec 35 œufs sur 1-2 rangs; utérus postérieur long de 1.7 mm avec 15 œufs sur 1-2 rangs. Oeufs de 78-96 x 46-57  $\mu\text{m}$ . Queue longue de 85  $\mu\text{m}$ , terminée par une pointe médiane recourbée ventralement, une pointe dorsale dédoublée et deux pointes latéro-ventrales (Figs 20, 23).

#### REMARQUES

Cette espèce a été décrite par LENT & FREITAS (1940) chez *P. hastatus* au Brésil. Il n'y a pas de différences notables entre nos observations et la description originale. La bourse caudale a été observée en détail et dessinée par ces auteurs, qui relèvent une forte variation dans la disposition des côtes constituant la côte dorsale. Nous avons observé également une certaine variation (Fig. 15), mais pas de disposition comparable aux figures 12 et 17 de LENT & FREITAS (1940), qui nous paraissent par ailleurs sortir d'une variation intraspécifique et relever plutôt de la tératologie.

Les prévalences observées sont élevées chez les hôtes du genre *Phyllostomus*: 1 *P. hastatus* parasité sur 1 examiné au Paraguay, au Brésil ainsi qu'au Pérou; 2 parasités sur 2 examinés provenant du Surinam; 14 parasités sur 17 examinés provenant de Colombie; 2 *P. elongatus* parasités sur 8 examinés au Pérou. Au contraire, 3 *Sturnira lilium* parasités sur 121 examinés au Paraguay, ce qui pourrait indiquer que cet hôte est accidentel.

#### DISCUSSION

Les Trichostrongles parasites de Chiroptères possédant une tête armée sont classés dans 7 genres.

*Biacantha* Wolfgang, 1954 (2 espèces) est caractérisé par 2 épines ventrales et *Websternema* Vaucher & Durette-Desset, 1986 (1 espèce) par 2 épines latérales.

Trois genres, *Histiostrongylus* Molin, 1861 (2 espèces), *Parahistiostrongylus* Perez Vigueras, 1941 (1 espèce) et *Neohistiostrongylus* Barus & Ryšavý, 1971

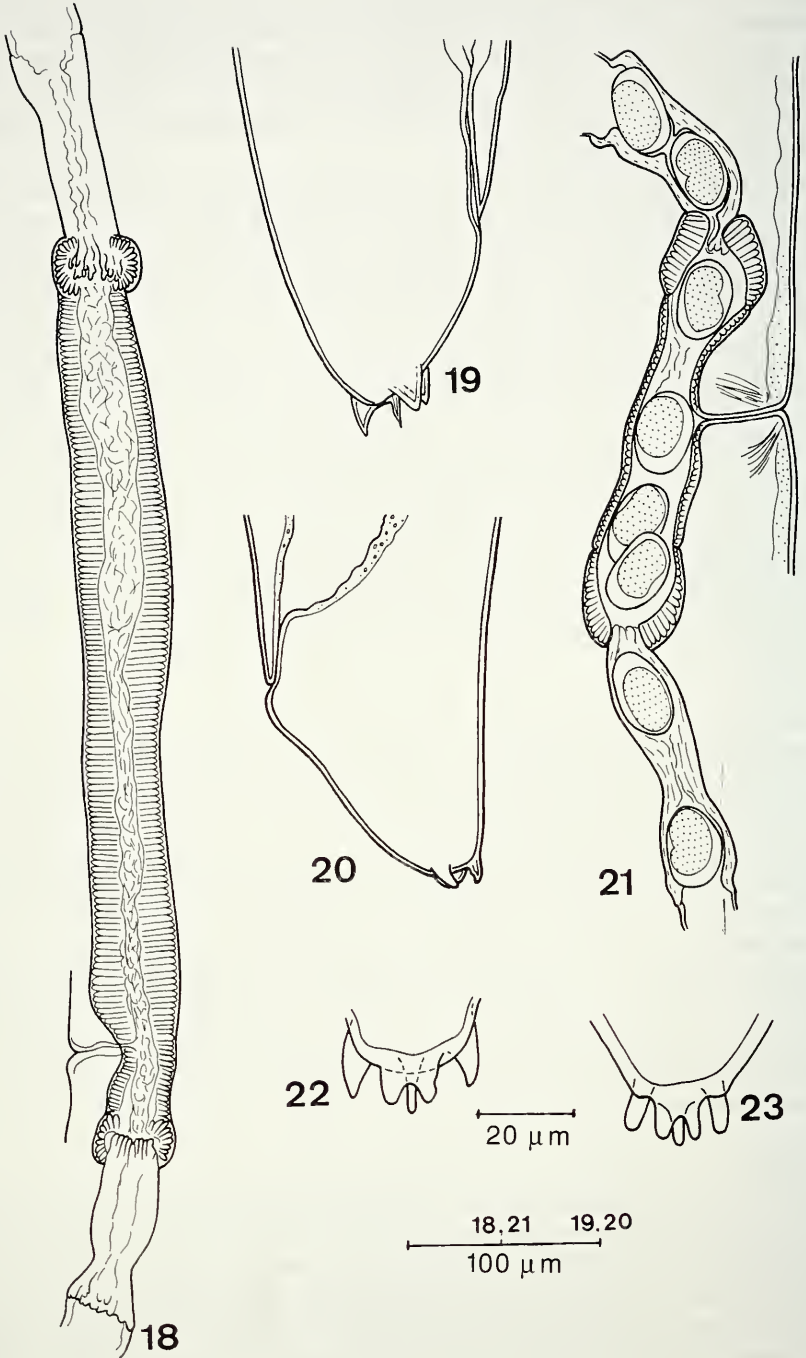

(1 espèce) possèdent une tête armée de 8 épines disposées régulièrement. Les deux premiers genres sont proches puisque différents auteurs (YAMAGUTI 1961; BARUS & RYŠAVY 1971; DURETTE-DESSET & CHABAUD 1975) les ont considérés comme synonymes. Cependant DURETTE-DESSET (1983) revalide *Parahistiostrongylus* en s'appuyant sur les caractères du vestibule, fortement asymétrique chez *Histiostrongylus*, sur la morphologie des spicules et sur l'absence de gubernaculum chez *Parahistiostrongylus*.

BARUS & RYŠAVY (1971) ont proposé le genre *Neohistiostrongylus* pour classer *Parahistiostrongylus viguerasi* Lopez-Neyra, 1946, parasite de *Myotis myotis* (Vespertilionidae) en Espagne. Ce genre est caractérisé par deux ailes latérales, présentes tout le long du corps, par des spicules courts divisés profondément en 3 branches, par un revêtement épineux de la face interne de la bourse caudale et par la présence d'un gubernaculum. Ce genre nous paraît donc valide.

*Linustrongylus* Vaucher & Durette-Desset, 1986, monotypique, possède aussi 8 épines, mais elles sont réparties en deux groupes symétriques sur les faces médianes; de plus, la bouche est entourée d'un cadre buccal (VAUCHER & DURETTE-DESSET 1986).

Le dernier genre, *Spinostromylus* Travassos, 1935 (2 espèces) présente 14-16 épines simples ou dédoublées, suivies de rangées de très petites épines en arrière de la tête; il est donc très différent des précédents. *Spinostromylus* est connu d'Egypte et de Chine. Avec *Neohistiostrongylus*, décrit d'Espagne, il se distingue, par sa répartition zoogéographique, des autres taxa à tête armée, qui sont connus seulement du Nouveau Monde.

DURETTE-DESSET & CHABAUD (1975) considéraient les espèces possédant un petit nombre de crochets comme primitives et estimaient que les espèces pourvues d'une armature plus complexe tendaient à perdre leur synlophe. Avec les nouvelles données que nous apportons, cette corrélation paraît moins nette, puisque *Histiostrongylus* et *Parahistiostrongylus*, qui possèdent des structures céphaliques déjà complexes, ont un synlophe formé de nombreuses crêtes, peu développées il est vrai. De toute manière, tous les synlophes présents dans ce groupe à tête armée sont caractérisés par de petites crêtes, orientées perpendiculairement à la paroi du corps. Seuls *Spinostromylus* et *Linustrongylus* sont totalement dépourvus de synlophe. Les mêmes auteurs se demandaient si les formes armées formaient un groupe monophylétique. Il ne nous a pas été possible de mettre en évidence une ou plusieurs synapomorphies communes à ces quelques genres. Au contraire, elles forment un ensemble hétérogène: les bourses caudales présentent des dispositions de côtes diverses. Par exemple, les côtes 4 sont nettement plus courtes que les côtes adjacentes chez *Histiostrongylus*,

#### FIGS 18-23

Figs 18, 19, 22: *Histiostrongylus spineus* n. sp., chez *Phyllostomus discolor*. 18 - paratype femelle, ovéjecteur; 19 - queue d'une femelle; 20 - femelle, extrémité postérieure. (18, 22: 25152 INVE; 19: MNHN, 844 KP). — Figs 20, 21, 23: *Parahistiostrongylus octacanthus* Lent & Freitas, 1940. 20 - femelle, ovéjecteur; 21 - queue d'une femelle; 23 - femelle, extrémité postérieure. (20, 23: 25174 INVE, *Phyllostomus elongatus*; 21: 25156 INVE, *Phyllostomus hastatus*).

*Parahistiostrongylus*, *Websternema* et *Neohistiostrongylus*. Chez *Linustrongylus*, toutes les côtes sont courtes et trapues, elles rappellent par conséquent la disposition rencontrée chez *Cheiropteronomia* Sandground, 1929, lobe dorsal excepté (DURETTE-DESSET & VAUCHER 1988). Des spicules longs caractérisent *Websternema*, *Histiostrongylus* et *Linustrongylus*. L'extrémité des spicules est divisée en trois branches chez *Neohistiostrongylus*, *Histiostrongylus* et *Biacantha*. La queue des femelles est pourvue d'une seule pointe chez *Spinostromylus*, dans tous les autres genres il y a plusieurs pointes. Par conséquent, nous estimons qu'il n'existe pour l'instant aucun argument décisif pour considérer les espèces à tête armée comme un groupe naturel.

## REMERCIEMENTS

Aux participants de l'expédition du Muséum de Genève au Paraguay en 1979 et en 1982 et particulièrement à François J. Baud (Muséum de Genève) pour l'identification des hôtes; à Alain de Chambrier, Thierry Jaccoud (Muséum de Genève) et Carlo Dlouhy (Asuncion) pour leurs récoltes au Nicaragua et au Brésil; au ministère de l'Agriculture et des Elevages du Paraguay, au ministère de l'Agriculture du Pérou à Lima et Iquitos ainsi qu'au personnel de la station biologique "Pithecia" de Samiria (prov. Loreto, Pérou) pour les facilités accordées lors du travail de terrain.

## BIBLIOGRAPHIE

- BARUS, V. & RYŠAVY, B. 1971. An analysis of the biogeography of Nematodes of the family Trichostrongylidae parasitizing Bats of the suborder Microchiroptera. *Folia Parasitologica* 18: 1-14.
- BARUS, V. & DEL VALLE, M. T. 1967. Systematic Survey of Nematodes Parasitizing Bats (Chiroptera) in Cuba. *Folia Parasitologica* 14: 121-140.
- DURETTE-DESSET, M. C. 1983. Keys to genera of the superfamily Trichostrongyloidea. In: ANDERSON, R. C. & CHABAUD, A. G. (eds). CIH Keys to the nematode parasites of vertebrates. *Commonwealth Agricultural Bureaux*, Slough. 86 pp.
- DURETTE-DESSET, M. C. & CHABAUD, A. G. 1975. Nématodes Trichostrongyloidea parasites de Microchiroptères. *Annales de Parasitologie humaine et comparée* 50: 303-337.
- DURETTE-DESSET, M. C. & VAUCHER, C. 1988. Trichostrongyloidea (Nematoda) parasites de Chiroptères néotropicaux. II. Nouvelles données sur le genre *Cheiropteronomia* Sandground, 1929. *Revue suisse de Zoologie* 95: 889-899.
- LENT, H. & TEIXEIRA DE FREITAS, J. F. 1940. *Histiostrongylus octacanthus* n. sp. (Nematoda: Strongyloidea). *Arquivos do Instituto Benjamin Baptista* 6: 91-96.
- LOPEZ-NEYRA, C. R. 1946. *Paralitiostromylus vigerasi* sp. n. Trichostrongylidae, nuevo de Quiropteros en Espana. *Revista ibérica de Parasitologia* 6: 245-256.
- MOLIN, R. 1861. Il sottordine degli acrofalli ordinato scientificamente secondo i risultamenti delle indagini anatomiche ed embriogeniche. *Memorie del Reale Istituto Veneto di Scienze, Lettere ed Arti, Venezia* 9: 427-633.
- PÉREZ VIGUERAS, I. 1941. Nota sobre el genero *Histiostrongylus* Molin, 1861. *Revista de Medicina Tropical y Parasitologia* 7: 67-72.
- VAUCHER, C. & DURETTE-DESSET, M.-C. 1986. Trichostrongyloidea (Nematoda) parasites de Chiroptères néotropicaux I. *Websternema parnelli* (Webster, 1971) n. gen. n. comb. et *Linustrongylus pteronoti* n. gen. n. sp., parasites de *Pteronotus* au Nicaragua. *Revue suisse de Zoologie* 93: 237-246.
- YAMAGUTI, S. 1961. Systema Helminthum vol. 3: The Nematodes of Vertebrates. *Interscience Publ., New York*, 1261 pp.

## A new apterous and microphthalmic species of *Anemadus* (Coleoptera: Leiodidae: Cholevinae) from China

Jan RUŽIČKA

Department of Ecology, Faculty of Forestry, Czech Agricultural University  
CZ-165 21 Praha 6, Czech Republic; e-mail: ruzicka@lf.czu.cz

**A new apterous and microphthalmic species of *Anemadus* (Coleoptera: Leiodidae: Cholevinae) from China.** - *Anemadus smetanai* sp. n. is described from China, Yunnan province. Its diagnostic characters including male and female genitalia are illustrated. The species differs from all other species of *Anemadus* Reitter, 1885 by microphthalmism, absence of metathoracic wings, elytra coalescent and coined with scutellum, ventrites with a pair of antero-lateral processes and female sternum VIII with concave spiculum ventrale.

**Key-words:** Taxonomy - Coleoptera - Leiodidae - Cholevinae - *Anemadus* - China - Yunnan province.

### INTRODUCTION

The genus *Anemadus* Reitter, 1885 is the largest genus of the tribe *Anemadini* Hatch, 1928 (sensu NEWTON & THAYER 1992). The genus was reviewed by GIACHINO & VAILATI (1993) with 28 valid species recognized, distributed from central and southern Europe, Turkey, Middle East, Iran to Pakistan and northern India. Later, a further species was described from China, Sichuan province (PERREAU 1996a), and two species were described from Taiwan and Japan (PERREAU 1996b).

In this paper, a new species of this genus (collected recently by Aleš Smetana in China) is described. It has several remarkable characters absent from other *Anemadini*, but known from endogenous and cavernicolous taxa.

The following abbreviations are used throughout the text: JRUC - collection of Jan Ružička, Praha; MHNG - Muséum d'histoire naturelle, Genève. Exact label data are cited for type material, separate lines are indicated by “/”, separate labels by “//”. The code in brackets, attached to locality data, refers to the habitat notes in the field book of the collector.

*Anemadus smetanai* sp. n.

Figs 1-13

**MATERIAL EXAMINED.** Holotype (♂), allotype (♀) and 3 paratypes (1 ♂, 2 ♀♀), labelled: “CHINA N Yunnan [prov.], Xue / Shan [mts] nr. Zhongdian / 3900m 25.VI.1996 / 27°49N 99°34E C41 // collected by / A. Smetana, J. Farkač / and P. Kabátek”; 1 paratype (♀): ditto, but “4050m, 24.VI.1996, C39”. Holotype is deposited in MHNG, allotype and paratypes in JRUC.

ETYMOLOGY. The new species is named after its collector, Aleš Smetana from Ottawa.

DESCRIPTION. *Male*. Body elongate, rust-brown, body length 2.45 mm and 2.70 mm (holotype), maximum body width 1.20 mm and 1.25 mm (holotype). Dorsum continually covered with short, recumbent, yellow setation.

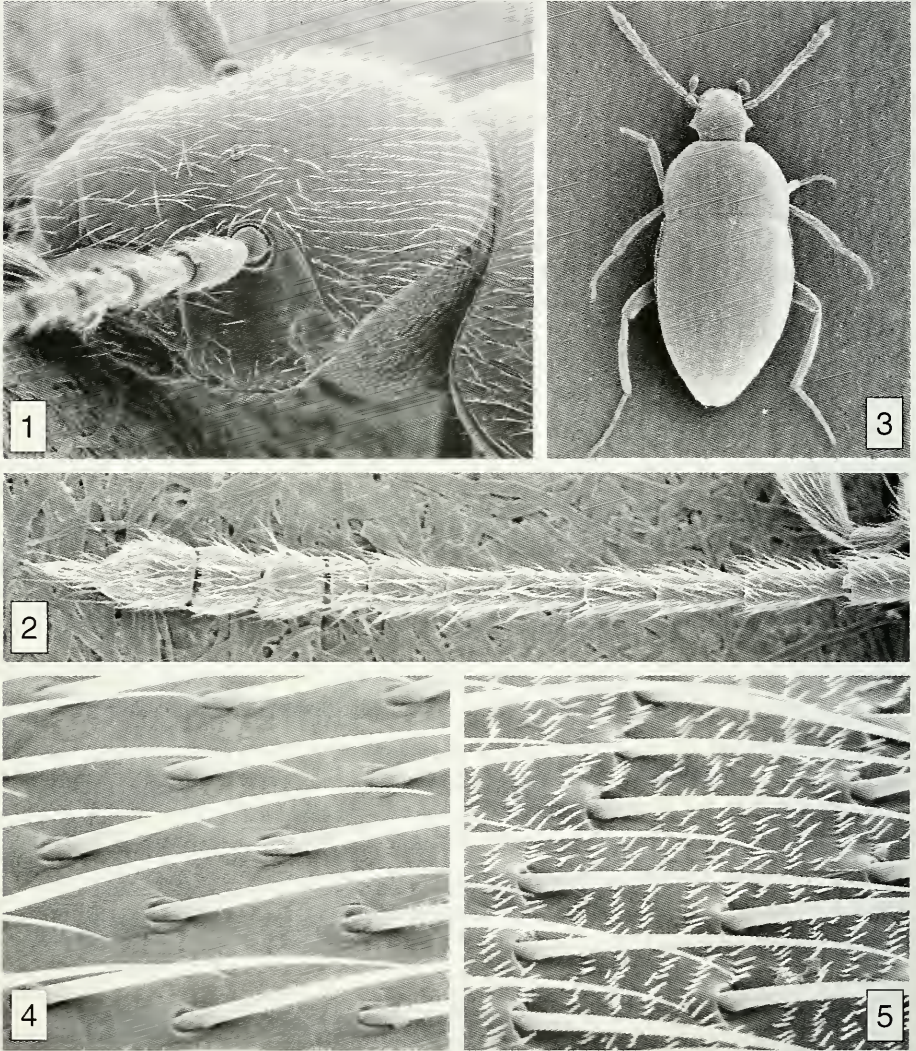

FIGS 1-5

*Anemadus smetanai* sp. n., female paratype. 1: head laterally; 2: left antenna dorsally; 3: habitus dorsally; 4: setation of pronotum dorso-laterally; 5: setation and microsculpture of elytra dorso-laterally.



Head 1.05 and 1.07 times as long as wide. Surface smooth, without distinct microsculpture (under 50x magnification), covered by fine, regularly distributed punctures, separated by 2-4 times of their diameter. Eye reduced to cluster of about 10 facets (Fig. 1). Clypeo-frontal suture distinctly developed. Clypeus transverse, trapezoidal.

Antenna (Fig. 2) elongated, 1.17 times as long as maximum pronotal width. Proportions of antennomeres in holotype (I to XI, length x maximum width): 24 x 9, 22 x 8, 20 x 7, 14 x 7, 16 x 7, 13 x 8, 14 x 10, 8 x 9, 13 x 11, 12 x 12 and 23 x 13.

Pronotum 1.60 times as wide as long, widest behind the mid-length, 1.95 times as wide as head. Lateral margin regularly rounded, posterior angles acute, produced posteriorly. Posterior margin regularly concave. Pronotal surface regularly convex, with a pair of weak, postero-lateral impressions (Fig. 3). Pronotal surface covered by distinct transverse microsculpture; intermixed granulate punctures arranged as dense as on head, but more superficially (Fig. 4).

Elytra oval, with slender, elongate apex. Elytra 1.45 and 1.49 times as long as maximum width, 2.50 and 2.52 times as long as pronotum and 1.07 times as wide as pronotum. Elytra coalescent, coined also with scutellum (Fig. 13). Each elytron apically rounded. Elytral surface with distinct transverse microsculpture. Punctures granulate, arranged into transverse, irregular rows (elytral type "a" in GIACHINO & VAILATI 1993; Fig. 5). Sutural stria absent. Large intermixed punctures, arranged into 8 irregular, longitudinal rows visible in elytron immersed to glycerine (not perceptible in dry mounted specimens). Metathoracic wings absent.

Protibia slender, gradually expanded toward apex. Protarsus slightly expanded, basiprotarsomere as wide as maximum protibial width. Mesotibia slightly curved, two basal mesotarsomeres expanded. Metatibia almost straight, 1.35 times as long as metatarsus, metatibia 0.77 and 0.78 times as long as maximum combined elytral width.

Mesosternal carina low, mesopraesternum posteriorly with sharp angle in lateral view. Metatergal apparatus reduced (Fig. 13). Metendosternite reduced, anterior part widely emarginate, posterior part shortened (Fig. 10). Ventrites IV to VII with sub-lateral part isolated by distinctly developed apodeme, antero-laterally present prominent process, tucked under posterior part of previous ventrite (as on Fig. 12).

Genital segment as on Fig. 8. Aedeagus regularly narrowed toward tip with elongate, subtruncate apex (Fig. 6). Internal sac with a pair of lateral rows, composed by sclerotized spines of different size and shape, medial part covered only by very minute toothlets, arranged in regular pattern (Fig. 6). Paramere constricted subapically, apex incurvate, bearing three large and one minute seta on inner margin (Fig. 7).

*Female.* Body length 2.75-3.05 mm (mean 2.92 mm in 4 specimens; for the same number of specimens given all means below), maximum body width 1.15-1.35 mm (mean 1.25 mm). Similar to the male, but body more robust, appendages less prolonged (Fig. 3).

Head 1.01-1.10 times as long as wide (mean 1.05). Antenna 1.06-1.12 times as long as maximum pronotal width. Proportions of antennomeres in one paratype (I to XI, length x maximum width): 26 x 9, 22 x 8, 18 x 4, 15 x 8, 16 x 7, 12 x 8, 16 x 11, 8 x 10, 13 x 12, 12 x 13 and 25 x 13.

Pronotum 1.61-1.73 times as wide as long (mean 1.65), 1.87-2.00 times as wide as head (mean 1.94).

Elytra 1.44-1.51 times as long as maximum width (mean 1.46), 2.60-2.70 times as long as pronotum (mean 2.65) and 1.08-1.12 times as wide as pronotum (mean 1.10).

Pro- and mesotarsomeres not expanded. Metatibia 1.25-1.29 times as long as metatarsus, 0.67-0.71 times as long as maximum combined elytral width (mean 0.69).

Ventrites IV to VII with similar sublateral apodeme and antero-lateral process as in males. Ventrite VIII with elongate spiculum ventrale with anterior margin only weakly sclerotized, distinctly concave (Fig. 9).

Tergum IX with lateral sclerotized line; apically with a single, minute seta; anterior and medial margin only weakly sclerotized. Tergum X ovoid, only weakly sclerotized anteriorly; posterior margin with two pairs of larger setae and several minute ones. Coxite small, subtriangular, bearing a single seta. Stylus elongate, with one basal, three subapical and one large, apical seta (Fig. 11).

AFFINITIES. *Anemadus smetanai* sp. n. belongs to the genus *Anemadus* Reitter, 1885 (sensu GIACHINO & VAILATI 1993) having the internal sac of aedeagus with two longitudinal rows of spines and lacking the medial dent.

The new species clearly differs from all other species of this genus by the following set of characters: (a) microphalmy (Fig. 1; eyes fully developed in other species of *Anemadus*): (b) absence of metathoracic wings, combined with elytra coalescent and coined also with scutellum (Fig. 13; metathoracic wings fully developed, elytra not coalescent in other species of *Anemadus*): (c) ventrites with a pair of antero-lateral processes (Fig. 12; such processes are lacking in other species of *Anemadus*): (d) ventrite VIII with spiculum ventrale concave in females (Fig. 9; ventrite VIII with spiculum ventrale convex in other species of *Anemadus*).

GIACHINO & VAILATI (1993) proposed several species groups in *Anemadus*, based mainly on the shape of the aedeagus, the spine pattern of the internal sac and the type of elytral microsculpture. Presently, it is impossible to place *A. smetanai* sp. n. to any of these species groups, because the characters of the aedeagus differ from those in other groups of *Anemadus*. The new species lacks basal enlarged spines and possesses two lateral, longitudinal rows of larger spines of the internal sac, a similar shape of the apex of the aedeagus and elytra with microsculpture of the type "a" (according to GIACHINO & VAILATI 1993) similarly as in members of the *A. strigosus* (Kraatz, 1852) species group (*A. strigosus*, *A. bianchii* Reitter, 1906 and *A. arcadius* Reitter, 1885, from Europe and Asia Minor). However, in *A. smetanai* sp. n., the spines of the internal sac are generally much more larger (minute and more homogenous in species of the *A. strigosus* group). Furthermore, *A. smetanai* sp. n. differs in the shape of apex of the parameres which are distinctly incurvate (always distinctly turned outwards in members of the *A. strigosus* species group).

Two of the three other recently described species of *Anemadus* from China, Taiwan and Japan were not placed in any species group (PERREAU 1996a, b). Furthermore, other species of this genus are currently described from China (M. Perreau, pers. comm.). Consequently, I presently refrain from defining a new species group for *A. smetanai* sp. n.

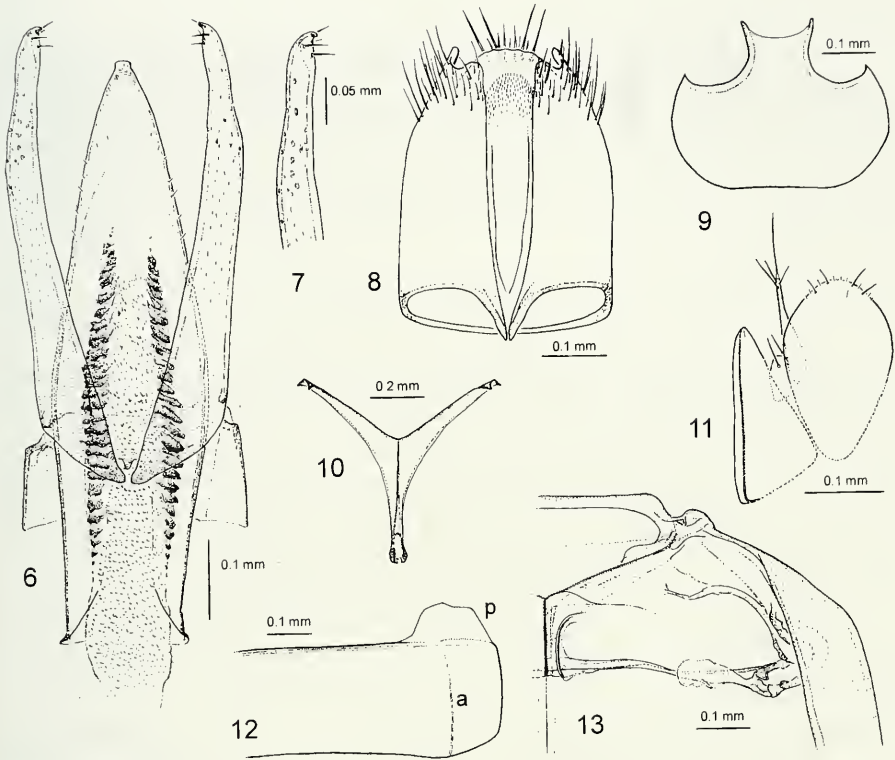

FIGS 6-13

*Anemadus smetanai* sp. n. 6: aedeagus dorsally; 7: apex of left paramera dorsally; 8: male genital segment ventrally; 9: female ventrite VIII ventrally; 10: female metendosternite postero-dorsally; 11: female genitalia dorsally; 12: lateral part of female ventrite V ventro-laterally, a - apodeme, p - antero-lateral process; 13: female metatergal apparatus, basal part of left elytron and scutellum ventrally.

The isolated position of *A. smetanai* sp. n. may be strongly influenced by the life of the species in the montane deep litter conditions. Similar changes in external morphology (reduction of eyes, coalescent elytra and/or reduction to loss of metathoracic wings) are known also in other edaphophile species of Cholevinae, e.g. *Choleva leucopthalma* Fiori, 1899 (SOKOLOWSKI 1941), several species of *Ptomaphagus* (*Adelops* Tellkampff, 1844) (PECK 1973, 1977, 1978a, PECK & GNASPINI 1997) and all species of *Ptomaphagus* (*Appadelopsis* Gnaspini, 1996) (PECK 1978b). However, *A. smetanai* sp. n. is the first such known case in *Anemadini* (sensu NEWTON & THAYER 1992).

**BIONOMICS.** Most of the specimens was sifted from deep layers of rotten leaves and detritus in montane primary forest (with dominant *Abies*, *Betula*, *Carpinus* and *Rhododendron* spp.), a single specimen was sifted from layers of moss, rotting bark and humus under it on a huge fallen fir (*Abies* sp.) in an primary high montane forest with dominant *Abies* and tree-like *Rhododendron* spp. (*A. Smetana*, pers. comm.).

## ACKNOWLEDGEMENTS

I am grateful to Aleš Smetana (Ottawa) for providing Chinese material of Cholevinae for study. Many thanks are due to Jana Nebesářová and Antonín Polák (Laboratory of Electron Microscopy, ASCR, České Budějovice) for help with the SEM photographs, Jakub Rolčík (Bi-MAC Graphics Inc., Praha) for assistance with mounting the SEM photographs and David Král for comments on the previous version of the manuscript.

## REFERENCES

- NEWTON, A.F. Jr. & THAYER, M.K. 1992. Current classification and family-group names in Staphyliniformia (Coleoptera). *Fieldiana: Zoology, New Series* 67: I-IV, 1-92 pp.
- GIACHINO, P.M. & VAILATI, D. 1993. Revisione degli Anemadinae Hatch, 1928 (Coleoptera Cholevidae), Monografie di Natura Bresciana No. 18, *Museo Civico di Scienze naturali di Brescia, Brescia*. 314 pp.
- PECK, S.B. 1973. A systematic revision and the evolutionary biology of the *Ptomaphagus* (*Adelops*) beetles of North America (Coleoptera: Leiodidae: Catopinae), with emphasis on cave-inhabiting species. *Bulletin of the Museum of Comparative Zoology* 145: 29-162.
- PECK, S.B. 1977. The subterranean and epigeal Catopinae of Mexico (Coleoptera: Leiodidae). *Bulletin of the Association for Mexican Cave Studies* 6: 185-213.
- PECK, S.B. 1978a. New montane *Ptomaphagus* beetles from New Mexico and zoogeography of southwestern caves (Coleoptera: Leiodidae: Catopinae). *The Southwestern Naturalist* 23: 227-238.
- PECK, S.B. 1978b. Systematics and evolution of forest litter *Adelopsis* in the southern Appalachians (Coleoptera: Leiodidae: Catopinae). *Psyche* 85: 355-382.
- PECK, S.B. & GNASPINI, P. 1997. *Ptomaphagus inyoensis* n.sp., a new microphthalmic montane beetle from California (Coleoptera: Leiodidae: Cholevinae: Ptomaphagini). *The Canadian Entomologist* 129: 769-776.
- PERREAU, M. 1996a. Contribution à la connaissance des Cholevidae du Japon et de Taiwan (Coleoptera). *Revue suisse de Zoologie* 103: 283-297.
- PERREAU, M. 1996b. Nouveaux Cholevinae d'Asie (Coleoptera Leiodidae). *Revue suisse de Zoologie* 103: 939-949.
- SOKOLOWSKI, K. 1941. *Choleva leucophthalma* Fiori (Col., Catopidae) (Catopiden-Studien III). *Mitteilungen der Münchner Entomologischen Gesellschaft* 31: 943-948.

## The genus *Proscopia* Klug, 1820 (Orthoptera, Caelifera, Eumastacoidea, Proscopiidae) in Central America, with description of a new species

Alba BENTOS-PEREIRA<sup>1</sup> & C. Hugh F. ROWELL<sup>2</sup>

<sup>1</sup> Facultad de Ciencias - Entomología, Universidad de la República, Casilla 490, 11200 Montevideo, Uruguay.

<sup>2</sup> Zoologisches Institut der Universität Basel, Rheinsprung 9, CH-4051 Basel, Switzerland.

**The genus *Proscopia* Klug, 1820 (Orthoptera, Caelifera, Eumastacoidea, Proscopiidae) in Central America, with description of a new species.** - *Corynorhynchus septentrionalis* (Bruner) from Panama and Costa Rica is the only proscopiid known to occur in Central America. Here we show that the specimens previously allocated to this taxon actually comprise at least two and probably three species of the genus *Proscopia*. We describe *P. panamensis* n. sp. and redescribe *P. septentrionalis* (Bruner) (reinstated comb.). We are unable to describe the third taxon due to lack of adult material.

**Key-words:** Orthoptera - Caelifera - Proscopiidae - taxonomy - Central America.

### INTRODUCTION

In the most recent revision of the family Proscopiidae, JAGO (1989) noted that the genus *Corynorhynchus* was in need of revision, as many of its species were in his opinion badly identified. One of the most difficult taxa to place has been the species *septentrionalis* Bruner, 1905, the most northerly proscopiid known and the only one recorded from Central America. This species was originally described in the poorly defined genus *Taxiarchus*, later transferred to *Proscopia* by HEBARD (1924), and most recently to *Corynorhynchus* by JAGO (1989). The confused situation has been exacerbated by the paucity of specimens. Bruner's description was based on two specimens from Pozo Azul de Pirrís, Costa Rica, which he described as being a ♂ and ♀; in fact both are ♀♀, one adult and one larva, as originally noted by HEBARD (1924). HEBARD also cited two further specimens collected by D.E. Harrower in Gatún, Canal Zone, Panama, one adult ♂ and one ♀ larva. JAGO (1989) cited a further ♂ collected by Schrader from Barro Colorado Island, Canal Zone, Panama, belonging to the collection of the Academy of Natural Sciences, Philadelphia (ANSP); he also mistakenly recorded the lectotype ♀ as coming from Panama, instead of Costa Rica.

We recently located two more adult ♀♀ and one adult ♂ in the collections of the Instituto Nacional de Biodiversidad (INBio), Costa Rica, and an adult ♂ and a ♀

larva in those of the Smithsonian Tropical Research Institute in Panama (STRI). Additionally we collected two further specimens (an adult ♀ and a ♀ larva) on Cerro Copé, Panama, in September 1997. We have used all these specimens, including the type series from the ANSP, to review the Central American proscopiids, as part of an on-going revision of the entire family (Bentos-Pereira, in progress)<sup>1</sup>. We show here that there are in fact at least two Central American species, one from Costa Rica (*septentrionalis* Bruner), which we redescribe, and another species (*panamensis* n. sp.) from Panama. There is probably a second new species among the specimens, but there is to date insufficient material for a description. All three must be attributed to the genus *Proscopia* as it is currently defined.

## METHODS

For the description of the ♂ internal genitalia we use the terminology proposed by JAGO (1989); his diagram is reproduced in Figure 1. Numbers in the text following an anatomical term refer to this diagram. We also use the structure of the ♀ spermatheca as a systematic character, based on the description and classification of this structure in the Proscopiidae given originally by DESCAMPS (1973). All measurements were made under the microscope with a digital read-out micrometer stage and an eyepiece graticule. The measured dimensions are defined in Figures 2, 3, & 4.

## DESCRIPTIONS

### 1. *Proscopia septentrionalis* (Bruner, 1905), reinstated combination

#### SYNONYMY

*Taxiarchus septentrionalis* Bruner, 1905: 313-315, pl. 1; 1908: 342. KIRBY 1910: 87 (mistakenly assigns the species to Rehn). CAUDELL 1911: 159 (mentions Kirby's error). OTTE 1978: 34 (location of types).

*Proscopia septentrionalis* (Bruner); HEBARD 1924:93 (lectotype selected). MELLO LEITAO 1939: 417. CARBONELL 1977: 24.

*Corynorhynchus septentrionalis* (Bruner); JAGO, 1989: 273 (mistakenly assigns the species to Bruner).

#### SPECIMENS EXAMINED

COSTA RICA: Prov. San José: Pozo Azul de Pirrís, June 1905 (M. A. Carriker), 1 adult ♂, specimen nos. H233, CSC2670, ABP224. Lectotype of *Taxiarchus septentrionalis* Bruner, 1905 (ANSP). COSTA RICA: Prov. Puntarenas: Osa Peninsula, Corcovado National Park, 18-23 March 1978 (D.H. Jansen), 1 adult ♂, in copulation, specimen nos. CRI001 687843, ABP229 (INBio). This is the first authentic record of a ♂ of this species. Same data as previous specimen, 1 adult ♀, in copulation, specimen nos. CRI001 687844, ABP 228 (INBio). COSTA RICA: Prov. Puntarenas: Osa Peninsula, Agua Buena, Fila Casa Loma, 500 mts, LS N296300 E514300, 28.2.1993 (M.A. Zumbado), 1 adult ♀, specimen nos. 146 MAZ.93, CRI002 510601, ABP 227 (INBio).

<sup>1</sup> The exceptions are the specimens collected by Harrower, which now appear to be missing from the ANSP collections. According to HEBARD (1924) their data were as follows: Panamá: Prov. Panamá: Gatún, 25-31 July 1916 (D.E. Harrower), one adult ♂ and one ♀ larva.

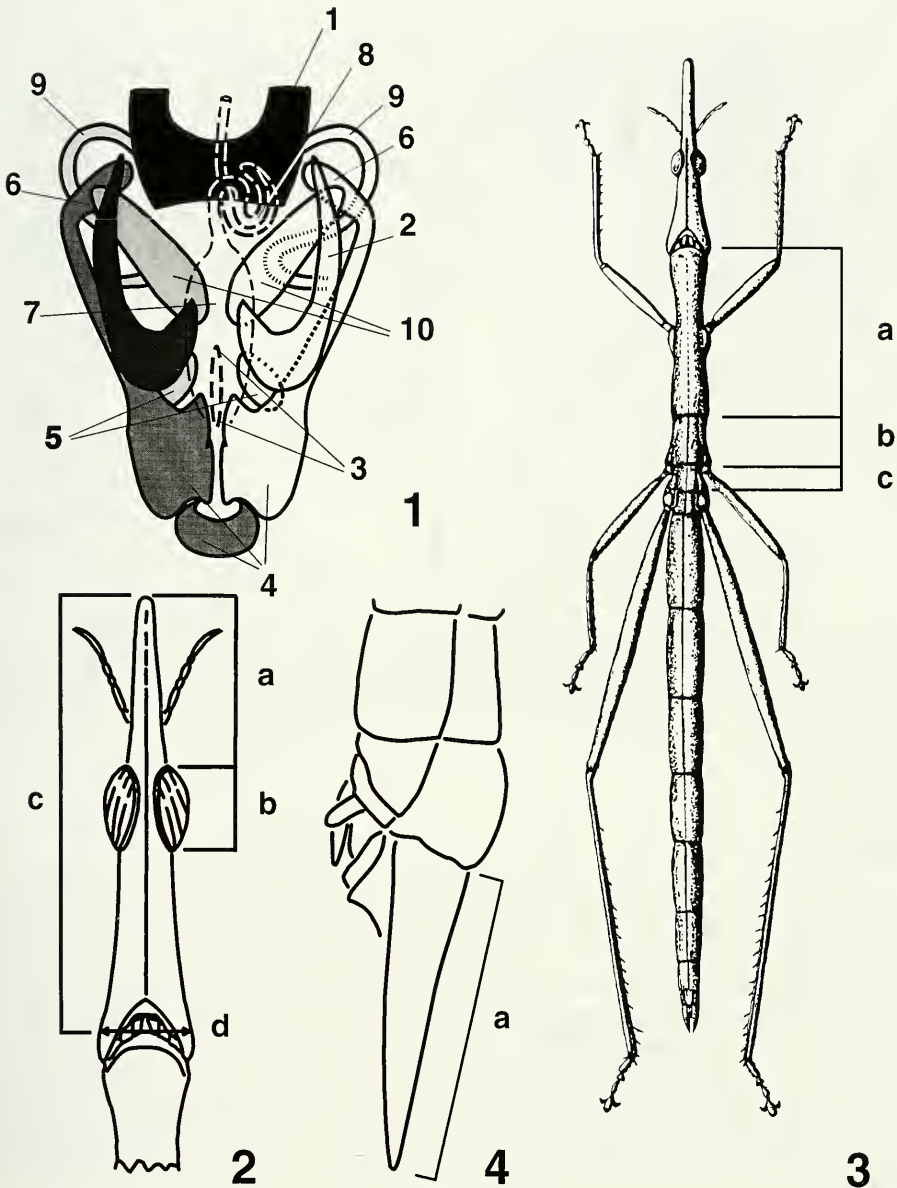

FIGS 1-4

FIG. 1. Diagram and nomenclature of the ♂ genital sclerites of the family Proscopiidae, after JAGO, 1989. 1: transverse plate of ectophallic membrane; 2: pair of hook-like lophi; 3: median dorsal slit or genital opening; 4: pair of valvular plates lateral to genital opening; 5: sublophal pair of accessory plates; 6: pair of anterior supplementary lateral plates; 7: distal ejaculatory sac; 8: proximal part of endophallic duct; 9: pair of semicircular lateral struts giving flexible attachment for lophi; 10: pair of plates overlying the anterior supplementary lateral plates (6). – FIG. 2. Dimensions of the head. a: rostrum; b: eye; c: total length of head; d: width of head. – FIG. 3. Dimensions of the thorax. a: pronotum; b: mesonotum; c: metanotum. – FIG. 4. Measure of length of the subgenital plate.

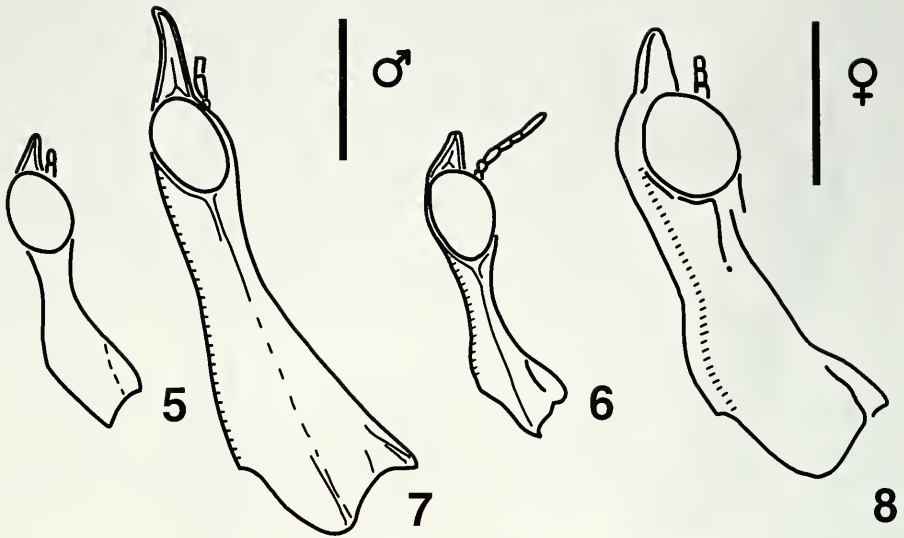

FIGS 5-8

5. Head of ♂ of *Proscopia septentrionalis*. Lateral view. Scale bar 3 mm. – 6. Head of ♂ of *Proscopia panamensis*. Lateral view. Scale bar 3 mm. – 7. Head of ♀ of *Proscopia septentrionalis*. Lateral view. Scale bar 5 mm. – 8. Head of ♀ of *Proscopia panamensis*. Lateral view. Scale bar 5 mm.

#### REDESCRIPTION

##### Male:

Genitalia (Figures 9, 11). Anterior transverse plate (1) united with the lophi (2), which terminate in strong hooks, curving upwards and converging towards the midline. This unitary plate is equivalent to an epiphallus. It is located in a delicate membrane which extends towards the anterior part of the aedeagus. Laterally this membrane unites the transverse plate with lateral plates (10) in the same plane. The same membrane extends posteriorly, covering the median slit (3), which extends almost to the posterior extremity of the aedeagus. In this species (but not in *panamensis*) the slit is closed posteriorly and below by the fused lateral plates (4), which form a very obtuse angle extending from in front of plate (1) almost to below plate (10). The fused lateral plates (4) articulate with the anterior complementary plates (6), which are not straight but twisted.

The median slit communicates with a pleated membranous chamber, in the floor of which opens a strongly sclerotized duct. This duct is tubular and opens proximally by means of a sclerotized valve. It is probable that during copulation the duct is not everted via the median slit, but that the pleated chamber acts as the intromittent organ, as in the closely related genus *Astromascopia* (Bentos, unpubl.), and that the sclerotized duct acts as an ejaculatory duct.



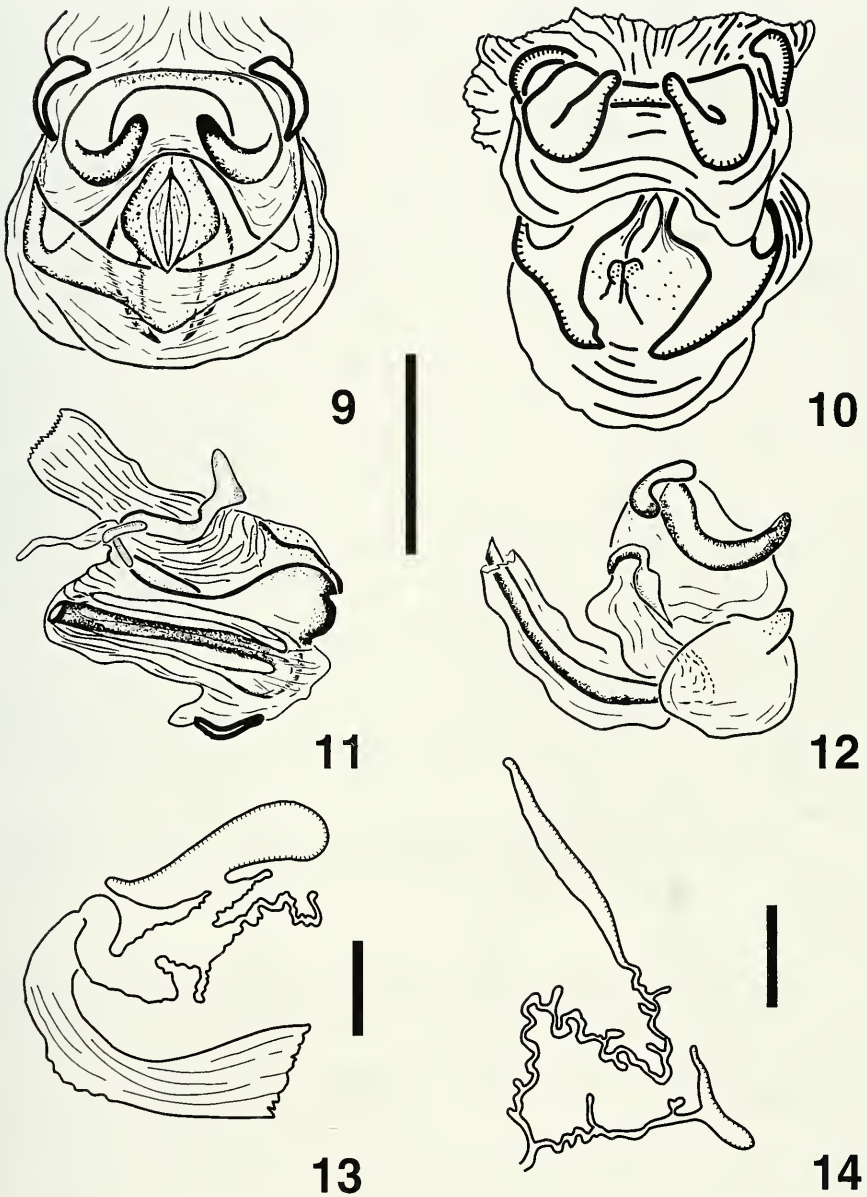

FIGS 9-14

9. Aedeagus of *Proscopia septentrionalis*. Dorsal view. Scale bar 1.5 mm. – 10: Aedeagus of *Proscopia panamensis*. Dorsal view. Scale bar 1.5 mm. – 11. Aedeagus of *Proscopia septentrionalis*. Lateral view. Scale bar 1.5 mm. – 12. Aedeagus of *Proscopia panamensis*. Lateral view. Scale bar 3 mm. – 13. Spermatheca of *Proscopia septentrionalis*. Scale bar 1 mm. – 14. Spermatheca of *Proscopia panamensis*. Scale bar 1 mm.

External morphology. Head delicate and elongate, markedly constricted behind the large globular eyes. Rostrum short, slightly inclined downwards, dorso-ventrally compressed, pointed tip somewhat rounded, the four edges weakly carinate (Figure 5). Coronary suture present. A small weak carina runs from the gena to the base of the eye. Antenna with 7 segments, antennal organs present on the sixth and seventh segments.

Thorax. Prothorax tubular, anterior and posterior edges of the pronotum smooth, the latter forming a raised annulus. Anteriorly and laterally there are two slight depressions lighter in colour than their surround, and medially two others matching the surround. Integument ornamented with relatively large tubercles, particularly noticeable above the well-developed pleural suture. Apterous. Mesonotum and metanotum not inflated. Midline with tegumentary ornamentation, but finer and less marked than in the prothorax. Mesothoracic pleural suture smooth, pleura without ornament. Metathoracic pleural suture carinate, pleura smooth. A single mid-line tubercle somewhat posteriorly on the metanotum. Prothoracic legs inserted near the midline of the prosternum, not laterally. Prothoracic femora with fine denticles, tibiae smooth, square in cross-section and with minutely serrate carinae, the external and internal ventral carinae bearing additionally 15 and 13 small spines respectively (15/13). Mesothoracic legs very similar, with 12/12 femoral spines. Metathoracic femur slightly inflated at the base, two dorsal carinae, integument finely denticulate. Metathoracic knees with two short dorsal spines. Metathoracic tibiae with 17/11 small dorsal spines, those of the inner row being longer; two small ventral and two large dorsal tibial spurs.

Abdomen. First abdominal notum similar to the metathoracic notum. The rest of the abdomen smooth, cuticle sparsely punctate, medial carina well-marked. Supraanal plate (Figure 17) with slightly convex margins terminating in a rounded process. Cerci simple, slightly inward curving, two thirds as long as supraanal plate; subgenital plate short and rounded (Figures 15, 19).

Coloration. Specimen CRI001 687843 was photographed alive in colour by the collector, P. De Vriess; the transparency shows a dark brown insect devoid of other markings.

*Female:*

Genitalia. Spermatheca of type 4 (DESCAMPS 1973), having a terminal ampulla with a small preapical diverticulum and one large and three small vermiform diverticula (Figure 13).

TABLE 1. Dimensions of ♂ of *P. septentrionalis* (mm).

Specimen number	INBio CRI001 687843
Length of head	9.9
Length of rostrum	1.38
Largest diameter of eye	2.88
Width of head (dorsally, at the level of the pronotum)	3.22
Length of pronotum	26.22
Length of mesonotum	2.59
Length of metanotum	2.36
Length of subgenital plate	2.67

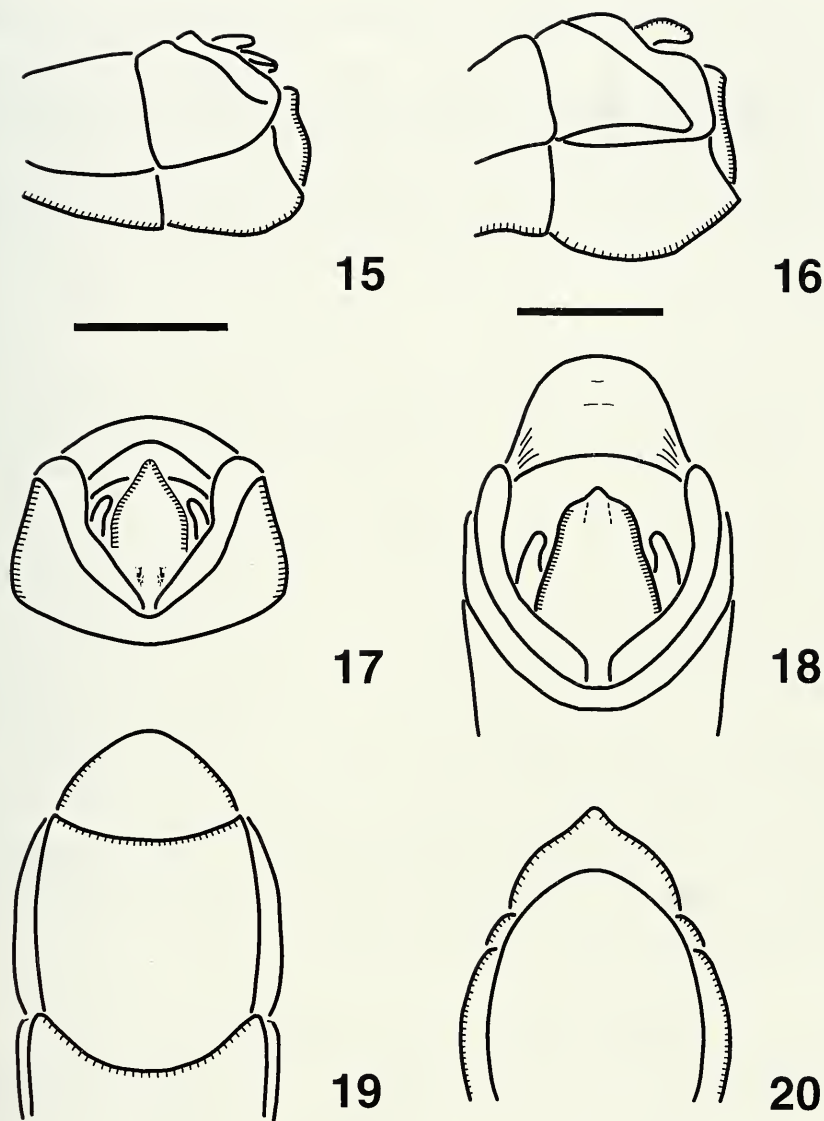

FIGS 15-20

15. Tip of abdomen of ♂ of *Proscopia septentrionalis*. Lateral view. Scale bar 1 mm. – 16. Tip of abdomen of ♂ of *Proscopia panamensis*. Lateral view. Scale bar 1 mm. – 17. Supraanal plate of ♂ of *Proscopia septentrionalis*. Scale bar 1 mm. – 18. Supraanal plate of ♂ of *Proscopia panamensis*. Scale bar 1 mm. – 19. Subgenital plate of ♂ of *Proscopia septentrionalis*. Scale bar 1 mm. – 20. Subgenital plate of ♂ of *Proscopia panamensis*. Scale bar 1 mm.

External morphology. Larger and more robust than the ♂, but generally very similar.

Head. Rostrum as in ♂ but slightly inclined upwards (Figure 7). The general shape of the head is somewhat less elegant than in the ♂; the same carinulae are present on the rostrum and on the genae. Coronal suture obsolete. Antennae broken.

Thorax. Prothorax similar to that of ♂. The ornamentation is proportionally somewhat coarser. There are no definite granules above the pleural suture, and the posterior margin of the pronotum is less marked. Meso- and metathorax very similar to ♂, not inflated and without wing rudiments. Pleura granulated, not smooth. A well-marked line of short spines on both episterna, similar to that of *Corynorhynchus spinosus*. Prothoracic legs as in ♂, bearing 12/13 small spines. Mesothoracic femur similar to prothoracic but with weaker carinae, tibia with 11/9 spines. Metathoracic femur slightly inflated basally, covered with denticles and bearing two prominent dorsal carinae. Metathoracic knees with two short dorsal spines. Metathoracic tibiae with 9/16 dorsal spines, smaller than expected in an insect of this size.

Abdomen. First segment similar to the thoracic segments, but flatter and with fewer granules. Pleural suture almost obsolete, without the carinae present in the ♂. The remaining abdominal segments are completely smooth, with a weak medial carina. Supraanal plate with slightly thickened margin, ending in an acute process (Figure 21). Cerci small, conical, about one fifth the length of the supraanal plate. Subgenital plate rounded, with a spatulate projection medially, which is slightly narrower basally than apically (Figure 23). Ovipositor valves large and strong, smooth.

Coloration. The specimen CRI002 510601 was photographed alive in colour by its collector, M. Zumbado. The photograph shows a uniformly dark reddish-brown insect, with a slightly paler abdomen, lacking all other markings. Tibial spines black. The specimen CRI001 687844 was similarly photographed by the collector, P. De Vriess. In this ♀ the ventral edges of the first 4 abdominal tergites are conspicuously edged with white, forming a tapering lateral stripe. The two collecting localities are only a few kilometres apart. In the holotype ♀ the pale markings are asymmetrical, being better developed on the left side than on the right.

TABLE 2. Dimensions of ♀♀ of *P. septentrionalis* (mm)

Specimen number	INBio CRI002 510601	INBio CRI001 687844	Holotype ABP 224
Length of head	14.71	13.85	15.3
Length of rostrum	3.06	2.73	3.0
Largest diameter of eye	3.74	3.34	3.4
Width of head (dorsally, at the level of the pronotum)	6.76	6.69	6.2
Length of pronotum	35.66	31.94	36.7
Length of mesonotum	6.31	4.47	5.5
Length of metanotum	4.23	4.84	5.1

## 2. *Proscopia panamensis* sp. n.

### SPECIMENS EXAMINED

Holotype. PANAMA: Prov. Panamá: Km 7.5, El Llano-Carti Road (87°55'W, 9°17'N), 9.5.96. (Hermógenes Fernández Marín), adult ♂. specimen nos. 98047. ABP 225 (STRI).

Paratypes. PANAMA: Prov. Coclé: Cerro Copé, 830 m, 20.9.1997 (C.H.F. Rowell & A. Bentos-Pereira), adult ♀. specimen nos 97532, ABP 81, alcohol specimen (ANSP). PANAMA: Same data as previous specimen (specimen no. 97533). ♀ larva, alcohol specimen (Museo Fairchild, University of Panama). PANAMA: Prov. Panamá: Barro Colorado Island, 27.8.77 (R. Silberglied & A. Aiello), ♀ larva, specimen no. 98048 (STRI).

### DESCRIPTION

#### Male:

Similar to the ♂ of *P. septentrionalis*, from which it differs as follows: Genitalia (Figures 10, 12). The genital complex is larger, robuster and (at least in our specimens) more strongly sclerotized, especially the lophi and the lateral plates. The medial slit is not closed below by fused lateral plates; in this species these remain separate, and extend laterally and posteriorly as far as the anterior complementary lateral plates (6). These latter are of a similar twisted shape to those of *P. septentrionalis* but are additionally folded back on themselves at the anterior end and are provided with sensory hairs.

External morphology. In general less gracile than *P. septentrionalis*. Head (Figure 6). Rostrum short with truncate tip. Rostral edges weakly carinate, the carinae not continuing beyond the eyes. Medial carina of occiput short, not continuing posteriorly beyond the middle of the eyes. Cuticle smooth.

Thorax. Pronotum with straight parallel lateral margins. Anterior margin smooth, posterior margin somewhat thickened and with a very slight medial embayment. Pleural sutures marked only by a line, not carinate. Cuticle of meso- and metanotum with numerous granules and transverse striae. Prothoracic femur square in cross-section, with serrate carinae and small tubercles, tibia with 11/12 spines. Mesothoracic femur practically smooth, tibia with 11/12 spines. Metathoracic femur strongly thickened in its basal half, with two weak dorsal carinae, denticles sparser and smaller than in *septentrionalis*. Metathoracic tibia with 10/16 relatively large spines.

Abdomen. 1st abdominal notum transversely striate, this condition continuing on succeeding abdominal segments in the midline only, the remaining areas smooth. Medial carina absent. Subgenital plate (Figure 16) normally short and rounded, longer and more pointed when the aedeagus is protruded (Figure 20). Supraanal plate shield-shaped with a sharply pointed medial terminal process (Figure 18).

Coloration. General coloration blackish-brown, tibial spines black.

#### Female:

The ♀♀ of the species *septentrionalis* and *panamensis* are easier to distinguish than are the ♂♂, especially by the structure of their spermathecae and subgenital plates. They are of the same length but *P. panamensis* is more gracile than *P. septentrionalis*.

Genitalia: Two spermathecae present, both with long, fine and convoluted ducts with numerous diverticula. The two distal ampullae differ. One is large, entire and

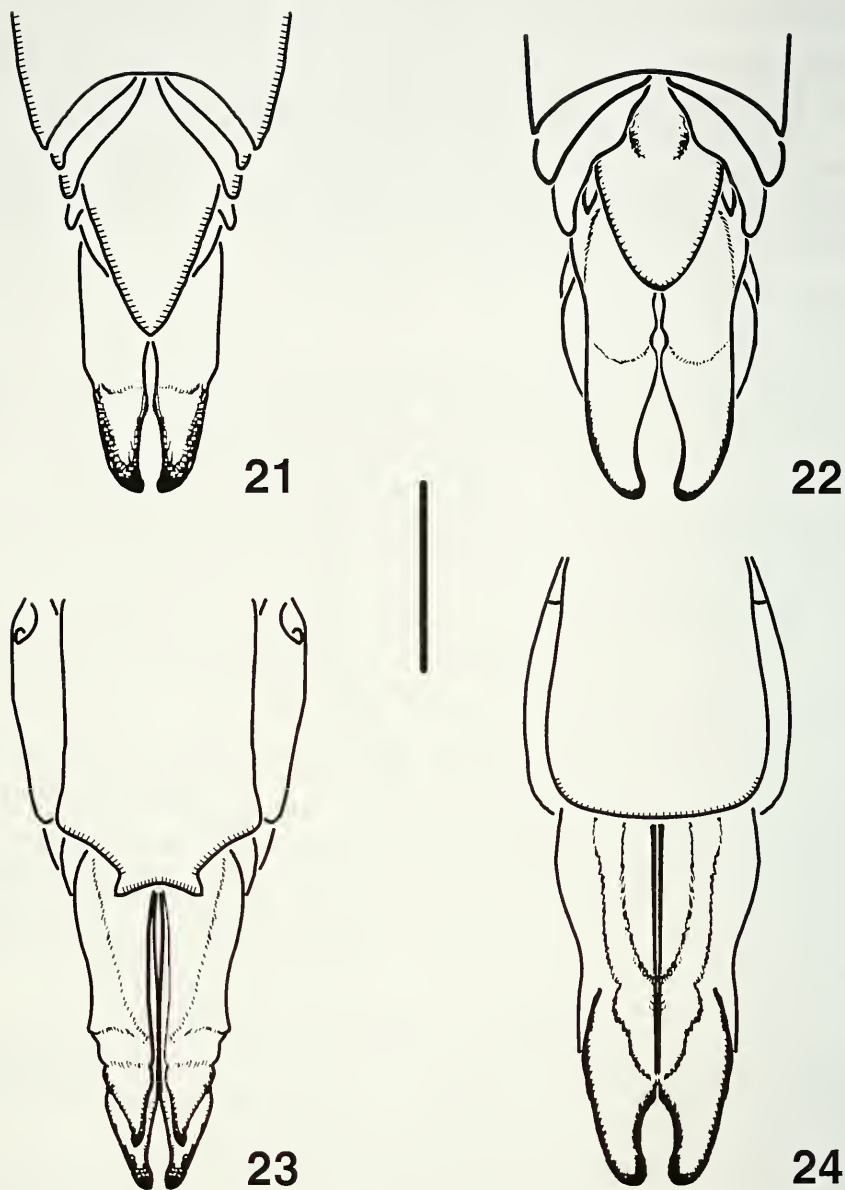

FIGS 21-24

21. Supraanal plate and ovipositor valves of *Proscopia septentrionalis*. Scale bar 5 mm. – 22. Supraanal plate and ovipositor valves of *Proscopia panamensis*. Scale bar 5 mm. – 23. Subgenital plate of ♀ of *Proscopia septentrionalis*. Scale bar 5 mm. – 24. Subgenital plate of ♀ of *Proscopia panamensis*. Scale bar 5 mm.

TABLE 3. Dimensions of ♂ of *P. panamensis* (mm)

Specimen number	98047, ABP 225 (Holotype)
Length of head	9.11
Length of rostrum	1.66
Largest diameter of eye	2.63
Width of head (dorsally, at the level of the pronotum)	4.2
Length of pronotum	23.69
Length of mesonotum	4.8
Length of metanotum	2.52
Length of subgenital plate	1.39

smooth; the other is smaller and divided into two diverticula, apical and preapical, the latter with a smaller digitiform prolongation (Figure 14).

External morphology. Head. Rostrum as in ♂ (Figure 8). Seen from the side the dorsal margin is decidedly more sinuous than in *septentrionalis*.

Thorax. Pronotum with straight margins and spiny cuticle. Some spines are large and conspicuous, particularly above the pleural suture. Margins as in *P. septentrionalis*. Meso and metanotum with a wide median band of granular cuticle. The extreme posterior of the metanotum is elevated and pleated, ending in a raised wavy margin. Pleural suture smooth in the mesonotum and marked by a carina in the metanotum. Pleura granular. The metathoracic epimeron has a medial carina. Apterous.

Prothoracic leg. Femur rounded and smooth; tibia quadrangular in cross section, 13/12 spines. Mesothoracic leg similar, 11/15 tibial spines. Metathoracic femur basally inflated and bearing 2 medial carinae, each with a line of tubercles; ventral surface with a single weak carina. Metathoracic knees with two short dorsal spines. Femoral cuticle is granular and similar to that of the pronotum. 16/11 tibial spines. The two more ventral tibial spurs are smaller, the two dorsal spurs somewhat larger and stronger.

Abdomen. The 1st abdominal segment bears a small anterior tubercle and transverse striations. The remaining abdominal segments smooth and minutely punctate, with a weak medial dorsal carina. Subgenital plate rounded and smooth, supranal plate pointed, cerci small and pointed. Ovipositor large and strong. Edges of the valves minutely toothed (Figures 22, 24).

Coloration. The living ♀ is olive green-brown on the head and thorax. The abdominal tergites are dark blackish brown with light yellow ventral margins, forming a conspicuous pale stripe along the sides of the abdomen from segments 2-8. Supraanal plate light brown, contrasting with the other abdominal tergites. Eyes reddish brown. Legs, dark brown, shading to black distally.

TABLE 4: Dimensions of ♀♀ of *P. panamensis* (mm).

Specimen number	Adult, 97532, ABP 81	Larva, 98048	Larva 97533, alcohol specimen
Length of head	12.6	7.6	11.4
Length of rostrum	1.9	1.66	1.3
Largest diameter of eye	3.3	2.63	2.1
Width of head (dorsally, at the level of the pronotum)	6.2	5.41	5.2
Length of pronotum	32.7	24.68	26.7
Length of mesonotum	5.3	3.1	4.0
Length of metanotum	4.8	3.88	4.1

### 3. *Proscopia* sp.

#### SPECIMENS EXAMINED

PANAMA: Prov. Panamá: Barro Colorado Island, 24 May 1957 (Schrader) adult ♂, specimen no. 98049 (ANSP). Specimen bears labels "A86 BCI. Panama 24.5.57 Schrader coll.", "Compared with type. ANSP has type. *Proscopia septentrionalis* ♂ Bruner. Det. Rehn 1958" in the handwriting of J.A.G. Rehn. "Male. Genitalia already removed (NDJ)" in handwriting of N.D. Jago. COSTA RICA: Prov. San José: Pozo Azul de Pirrís, June 1905 (M. A. Carriker), juvenile ♀, specimen no. 98050. Originally described by Bruner as the ♂ type of *T. septentrionalis* (ANSP).

As indicated on the label cited above, the genitalia were dissected from the only ♂ specimen (by Rehn?) prior to Jago's examination in the 1980s, but are no longer present and must be assumed lost.

The external morphology differs considerably from that of the previous species, and appears to indicate a different taxon. In the absence of an adult ♀ specimen and of the ♂ internal genitalia, however, the possibility cannot be excluded that either *P. panamensis* or *P. septentrionalis* is morphologically very variable or polymorphic and actually includes these specimens. The differences are as follows:

#### Male:

Head. Fastigium shorter than in *septentrionalis*, and somewhat more truncated than in *panamensis*. A medial carina runs from the tip of the fastigium to the occiput.

Thorax: A prominent medial carina runs along the entire thorax. Thorax without ornament, either dorsally or on the pleura, and lacking a metathoracic median tubercle. The pronotum is divided into two clearly marked regions, the anterior with a granular cuticle, the posterior smooth. The legs are damaged but seem different from those of the those other two species.

Abdomen. Well marked medial carina. Supraanal plate with a sharply pointed terminal process. Subgenital plate rounded and obtuse as in other *Proscopia* species.

#### Female (larva):

Rostrum identical to that of ♂ in shape and ornamentation, but proportionately longer. The adult ♀ rostrum is probably longer than that of *septentrionalis*.



Thorax. Meso- and metanotum have one lateral additional carina relative to the other two species. Legs: these are in better condition than in the ♂ specimen. Prothoracic femur square in cross-section with serrate edges, tibia similar with 16 external and 12 internal spines. Mesothoracic femur (only segment preserved) similar to that of prothorax. Metathoracic femur scarcely at all inflated at base, two well-marked dorsal carinae, knees with two large dorsal spines. Metathoracic tibia square in cross-section with serrate edges, 8 internal and 17 external spines, which are large and expanded at the base. Spurs identical to those of other species.

Abdomen. Terga similar to meso- and metanotum. Tip of supraanal plate broken, probably as in ♂. Subgenital plate straight.

TABLE 5. Dimensions of ♂ of *P.* sp. (mm)

Specimen number	98049
Length of head	9.0
Length of rostrum	2.0
Largest diameter of eye	2.2
Width of head (dorsally, at the level of the pronotum)	5.8
Length of pronotum	18.25
Length of mesonotum	(broken)
Length of metanotum	2.80
Length of subgenital plate	(broken)

## DISCUSSION

### GENERIC ATTRIBUTION

JAGO (1989: 273) defined the genus *Corynorhynchus* on the structure of the ♂ genitalia. He clearly states that the phallic complex of this genus lacks the transverse plate (1), that the lophi are greatly reduced and that the lateral plates (4) are reduced to a pair of angular spicules. The genus also lacks supplementary plates (6) and the genital duct is not sclerotized.

The two species which we describe above do not fit this description at all. The presence of a transverse plate (1), strongly fused to prominent and well sclerotized lophi and supported by lateral complementary plates (6), and the presence of well-developed lateral plates (4), are by contrast in accordance with JAGO's definition (1989: 282) of *Proscopia*. Additionally, his description of the manner in which the sclerotized ♂ genital duct joins the membrane in *Proscopia* corresponds exactly to the structure we see in our specimens. Our specimens conflict in some characters with Jago's definition: especially, in *panamensis* the lateral plates (4) are not fused posteriorly (though they are in *septentrionalis*) and they form a pod-like structure similar to that of *Cephalocoema*. There are also differences in the supraanal plate. However, Jago examined only two species of *Proscopia* (*aberrans* Hebard and *gigantea* Klug) and his definition may be unduly restrictive. No other genus fits our material better.

In this article we also present data on the ♀ spermatheca, which has previously been shown (BENTOS-PEREIRA 1997) to be useful within this group, particularly to

distinguish between closely related species. DESCAMPS (1973) did not describe the spermatheca of *Corynorhynchus*, but in other investigations (Bentos-Pereira, unpublished) it has proven to be of his Type 1, a simple spermatheca consisting of an ampulla at the end of a long duct. As described above, the spermathecae of the taxa described here are in contrast extremely complex; *P. panamensis* has a Type 4 spermatheca with two independent terminal ampullae and numerous diverticula, while that of *P. septentrionalis* is somewhat less complex, with one terminal ampulla and a single tube but with various diverticula. We have also found the subgenital plate to be useful, especially in the case of *P. septentrionalis*. This character was first used within the Proscopiidae by LIANA (1972, 1980). Although it is not as definitive as the aedeagus or the spermatheca, it supplies useful information.

All the described species of *Corynorhynchus* are markedly sexually dimorphic in the structure of the rostrum: the ♂ rostrum is roughly conical, but that of the ♀ has larger or smaller apical expansions. The rostra of *Proscopia*, on the other hand, like those of the closely-related (vide JAGO 1983) *Cephalocoema*, are not more dimorphic than one would expect from the difference in size between the sexes. In this character too the taxa treated here agree with other species of *Proscopia*, but not with those of *Corynorhynchus*. All in all we have no doubt that the former is the correct genus to which to assign the Central American proscopiid species.

In the absence of the internal genitalia we cannot be sure as to the generic placing of the third taxon described above, but to judge from the external morphology it too probably belongs to *Proscopia*.

#### DISTRIBUTION

*P. septentrionalis* has long been known as the most northerly proscopiid, and Pozo Azul de Pirrís near the south western coast of Costa Rica is often quoted as the northern limit of the family. The great rarity of the Central American species, however, and their very cryptic form and coloration, makes us doubt the necessity of this conclusion. It seems quite possible that these or similar species have a wider distribution in Central America than is currently known, at least on the Caribbean side, which has much wet forest. This speculation is supported by the probable presence of a third, as yet undescribed, species in both Panama and Costa Rica, which has previously evaded detection.

#### ACKNOWLEDGEMENTS

We thank A. Solís (InBio, Costa Rica), D. Quintero (University of Panama), A. Aiello (STRI, Panama) and D. Azuma (Academy of Natural Sciences, Philadelphia) for permission to examine specimens from their collections, D. Quintero, A. Aiello and N. Scott Pezet for logistic help in Panama, C. S. Carbonell for help and useful discussion and P. De Vriess and M. Zumbado for photographs of living specimens. Our Panamanian field work was performed during a visit to the Smithsonian Tropical Research Institute in Gamboa, Panama.

## REFERENCES

- BENTOS-PEREIRA, A. 1997. El genero *Astromascopeia* Jago 1989 (Orthoptera - Proscopiidae). *Tesis, PEDECIBA, Universidad de la República, Montevideo.*
- BRUNER, L. 1905. Two remarkable new Costa Rican locusts. *Entomological News* 16: 313-315, pl 1.
- BRUNER, L. 1908. Acrididae. In: Frederick DU CANE GODMAN (ed.), *Biologia Centrali Americana. Insecta, Orthoptera*, 2: 1-342, plates 1-4 (1900-1909). London, published for the Editor by R.H. Porter, 1893-1909.
- CARBONELL, C.S. 1977. Orthopterorum Catalogus 17. *The Hague: Dr. W. Junk.* 29 pp.
- CAUDELL, A.N. 1911. Some remarks on Kirby's Synonymic Catalogue of Orthoptera, Vol. 3, with additional notes on Vols. 1 and 2. *Entomological News* 22: 158-167.
- DESCAMPS, M. 1973. Notes préliminaires sur les genitalia de Proscopioidea (Orthoptera, Acridomorpha). *Acrida* 2: 77-95.
- HEBARD, M. 1924. Studies in the Acrididae of Panama (Orthoptera). *Transactions of the American Entomological Society* 50: 75-140, plates VI-VIII.
- JAGO, N.D. 1989. The genera of the Central and South American grasshopper family Proscopiidae (Orthoptera: Acridomorpha). *EOS (Madrid)* 65: 249-307.
- KIRBY, W.F. 1910. A synonymic catalogue of Orthoptera. Vol. 3, Orthoptera Saltatoria. Part 2 (Locustidae vel Acrididae). *British Museum, London.* 674 pp.
- KLUG, F. 1820. *Proscopia*, novum Insectorum Orthopterorum genus. *Horae Physicae Bero-linensis, Bonnae*, 15-26, plates 3, 4.
- LIANA, A. 1972. Etudes sur les Proscopiidae (Orthoptera). *Polska Akademia Nauk, Institut Zoologiczny, Annales Zoologici* 29: 381-459.
- LIANA, A. 1980. Materiaux pour la connaissance des Proscopiidae (Orthoptera). *Mitteilungen des Hamburger zoologischen Museums und Instituts* 77: 229-260.
- MELLO LEITAO, C. 1939. Estudio monográfico de los proscópiidos. *Revista del Museo de La Plata (NS)* 1: 280-449, pl XIII.
- OTTE, D. 1978. The primary types of Orthoptera (Saltatoria, Mantodea, Phasmatodea & Blattodea) at the Academy of Natural Sciences of Philadelphia. *Proceedings of the Academy of Natural Sciences, Philadelphia* 130: 26-87.



***Glomeris undulata* Koch and *G. conspersa* Koch are conspecific. - Enzyme electrophoretic evidence and taxonomical consequences (Diplopoda: Glomeridae)**

René HOESS & Adolf SCHOLL

University of Berne, Institute of Zoology, Division of Population Biology, Baltzerstr. 3, CH-3012 Berne, Switzerland.

***Glomeris undulata* Koch and *G. conspersa* Koch are conspecific. - Enzyme electrophoretic evidence and taxonomical consequences (Diplopoda: Glomeridae.** - Syntopic and allotopic populations of *Glomeris undulata* and *G. conspersa* have been investigated with enzyme electrophoresis. There was no evidence for separate gene pools of these taxa. However, *G. romana*, a species supposed to be closely related to *G. undulata* and *G. conspersa*, proved to be well differentiated based on allozyme data. We therefore conclude that the taxa *undulata* and *conspersa* are conspecific. Consequently, *G. conspersa* C. L. Koch, 1847, is a junior subjective synonym of *G. undulata* C. L. Koch, 1844 (nov. syn.). An analysis of the colour pattern provides arguments for the discussion why no intermediate forms exist.

**Key-words:** Diplopoda - *Glomeris* - revision - local alleles - morphology - distribution - new synonymy.

## INTRODUCTION

*Glomeris undulata* C.L.Koch, 1844, and *G. conspersa* C.L.Koch, 1847, are traditionally treated as two closely related but distinct species (cf. VERHOEFF 1911). They may be separated with reliability only by the form of the dorsal dark spots on the segments 2 to 12. These spots are parallel-sided in *G. undulata* and convergent posteriorly in *G. conspersa* (seen in walking position). Transitional forms that could indicate interbreeding of these taxa are very rare and have been named *G. undulata* var. *pseudoconspersa* (but see also VERHOEFF (1928b) for a case of assumed hybridisation). *G. undulata* and *G. conspersa* are often found syntopic, and large parts of their ranges overlap. Within the scope of an analysis of the genetic differentiation of the Central European *Glomeris* species by means of enzyme electrophoretic methods, we also examined syntopic and allotopic populations of *G. undulata* and *G. conspersa*. For comparison we included *G. romana* Verhoeff, 1900, a species which is supposed to be closely related to *G. undulata* and *G. conspersa* (cf. VERHOEFF 1911) but with a mainly allopatric distribution.

## MATERIAL AND METHODS

Population samples of *Glomeris undulata*, *G. conspersa*, and *G. romana* were analyzed genetically by using routine enzyme electrophoretic methods of our laboratory (SCHOLL *et al.* 1978). Vertical starch gel electrophoresis was conducted using the same buffer systems as in previous studies on *Glomeris* (HOESS *et al.* 1997). 18 enzyme loci were analyzed. The enzymes investigated and the loci scored (in brackets) are: aspartate aminotransferase (Aat-1, Aat-2), glyceraldehyd-3-phosphate dehydrogenase (Gapdh), glucose-6-phosphate isomerase (Gpi), hexokinase (Hk), leucine aminopeptidase (Lap), L-lactate dehydrogenase (Ldh-1, Ldh-2), malate dehydrogenase (Mdh-1, Mdh-2), malic enzyme (Me), mannose-6-phosphate isomerase (Mpi), peptidase (Pep), 6-phosphogluconate dehydrogenase (Pgd6), phosphoglucomutase (Pgm), superoxide dismutase (Sod-1, Sod-2) and sorbitol dehydrogenase (Sodh).

The zymograms were photographed on Polaroid for reference. We refer to observed electromorphs as alleles which are identified by their electrophoretic mobility (in mm) relative to electromorphs of previously studied species (HOESS *et al.* 1997). Mendelian inheritance of the alleles at a given locus was not tested by cross-breeding experiments but was concluded by analogy to results of previous studies of our laboratory (e.g. ZIMMERMANN & SCHOLL 1993). Allele frequencies and genetic distances were calculated with the BIOSYS-1 programme package (SWOFFORD & SELANDER 1989). Nei-distance D (NEI 1978) was used for the construction of an UPGMA dendrogram (SNEATH & SOKAL 1973). Bootstrap analysis was conducted with the PHYLIP programme package (FELSENSTEIN 1986-95). The bootstrap values are estimates from 100 replicates (bootstrap values levelled out at 100 replicates) with UPGMA as cluster algorithm and an unrooted consensus tree.

The following population samples (Fig. 1) were examined (number of specimens in brackets): *Glomeris undulata*: Switzerland: Böisingen (13), Brunnen (9), Ingenboehler Berg (15), Loucherhorn (6), Malans (6), Meride (7), Merishausen (8), Niderhorn (6), St-Gingolph (15); Germany: Ehingen (17); *G. conspersa*: Switzerland: Biel (10), Böisingen (20), Castagnola (3), Châtollion (14), Densbüren (10), Ingenboehler Berg (11), Loucherhorn (8), Malans (12), Meride (8), Merishausen (13), St-Gingolph (11), Valangin (10); Germany: Ehingen (20); France: Cruseilles (13); *G. romana*: Italy: Camaiore (18), Lucca (4).

Several other population samples have been collected (often with low sample sizes) and have been used in addition to literature data to produce a distribution map of the taxa *undulata* and *conspersa*.

Tergites of two selected specimens of *G. undulata* were drawn using a camera lucida. The specimens were turned around their axes in order to draw every part of the tergite in vertical view.

## RESULTS

Allele frequencies of the 18 loci of all samples are given in Table 1. For unknown reasons, several specimens in most samples failed to show activity at some

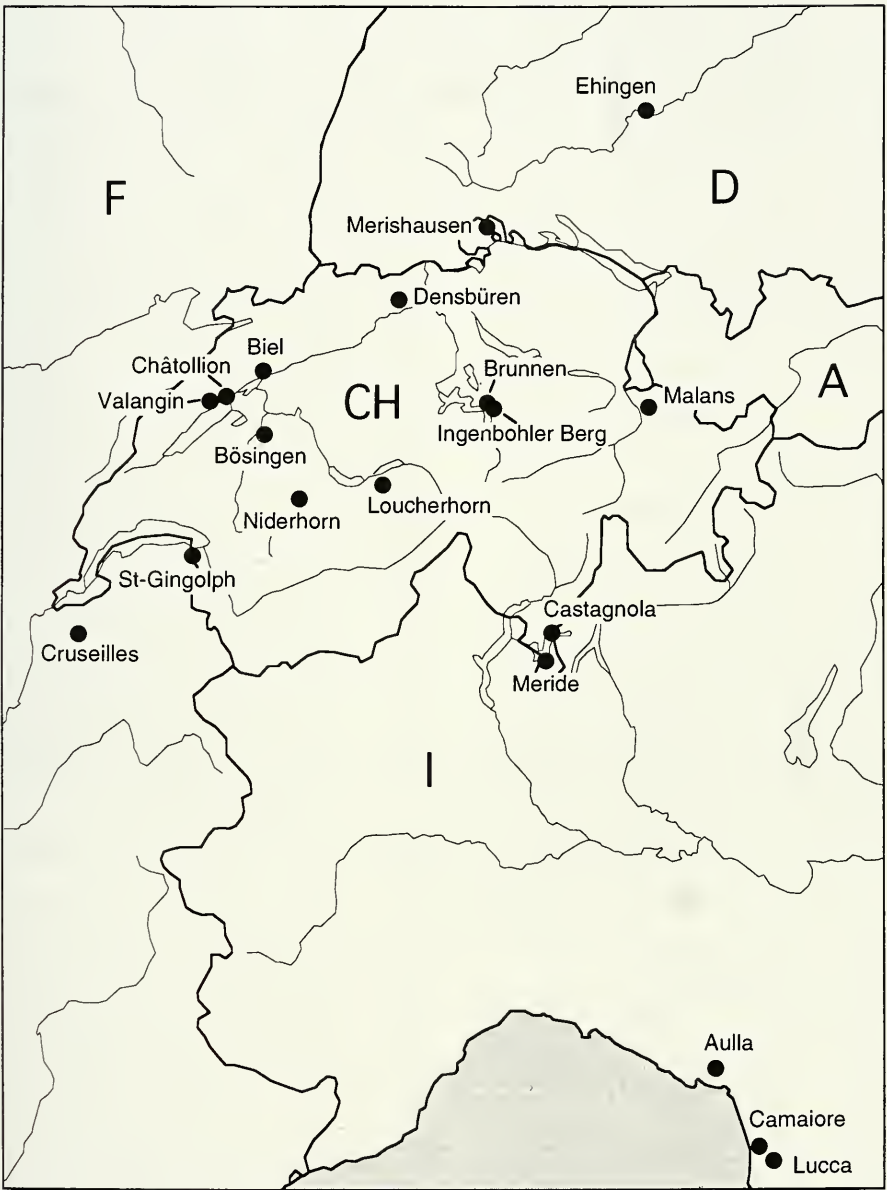

FIG. 1

Collecting sites in Switzerland and adjacent countries.

TABLE 1. - Allele frequencies at the 18 enzyme loci studied in *Glomeris undulata*, *G. conspersa* and *G. romana*. N = number of specimens scored at the respective locus.

Locus Allele	<i>G. undulata</i>									<i>G. conspersa</i>									<i>G. romana</i>								
	Ehingen	Mershhausen	Bödingen	St-Gingolph	Brunnen	Ingenbohrer Berg	Loutherhorn	Nidernhorn	Malans	Meride	Ehingen	Mershhausen	Densbüren	Biel	Châtillon	Valangin	Crusilles	Bödingen	St-Gingolph	Ingenbohrer Berg	Loutherhorn	Malans	Castagnola	Meride	Lucca	Canaiore	
Aat-1	0.25	-	-	-	-	-	-	-	-	-	0.07	-	-	0.04	-	-	-	-	-	-	-	-	-	-	-	-	-
	0.12	0.27	-	0.06	0.10	-	0.08	-	-	-	-	-	-	-	0.08	0.13	0.18	0.11	-	-	-	-	-	0.12	-	-	-
	-	-	-	-	-	-	-	-	-	-	-	-	-	-	-	-	-	-	-	-	-	-	-	0.12	0.06	-	-
	0.03	0.06	0.09	0.20	0.06	0.07	-	0.08	-	-	0.20	0.04	0.50	0.12	0.29	0.05	0.15	0.16	0.09	0.08	0.06	-	0.17	0.12	-	-	-
	0.03	-	-	-	-	-	-	-	-	-	-	-	-	-	-	-	-	-	-	-	-	0.08	-	-	-	-	-
	0.50	0.06	0.55	0.57	0.11	0.20	-	0.92	0.17	0.21	0.33	0.08	0.10	0.31	0.39	0.15	0.46	0.34	0.73	0.20	-	0.04	0.66	0.12	-	-	-
	-	0.25	-	-	0.33	0.16	0.92	-	-	0.07	-	0.42	-	-	-	0.25	0.08	0.03	-	0.22	0.75	-	-	-	-	-	-
	0.03	0.06	-	0.23	0.06	0.07	-	0.08	-	-	0.10	0.04	0.30	0.19	0.14	-	0.04	0.03	-	0.08	-	0.08	-	0.07	0.88	0.86	-
	-	-	-	-	0.06	-	-	-	-	0.72	-	-	-	-	-	0.05	-	-	-	-	0.13	-	0.17	0.57	-	-	-
	0.29	0.32	0.09	-	0.33	0.40	0.08	-	0.67	-	0.30	0.42	0.10	0.38	0.14	0.45	0.19	0.31	-	0.31	0.06	0.8	-	-	-	-	-
	-	-	-	-	-	-	-	-	-	-	-	-	-	-	-	0.05	-	-	-	-	-	-	-	-	-	-	0.08
(N)	17	8	11	15	9	15	6	6	6	7	20	12	10	8	14	10	13	19	11	18	8	12	3	8	4	18	-





107	-	-	-	-	-	-	-	-	-	-	-	-	-	-	-	-	-	-	-	-	-	-				
103	0.50	0.63	0.65	0.37	0.17	0.27	0.08	0.17	0.08	0.07	0.45	0.19	0.70	0.35	0.50	0.25	0.62	0.32	0.25	0.32	0.06	0.12	0.67	0.19	0.25	0.06
100	0.50	0.37	0.31	0.63	0.83	0.73	0.92	0.83	0.92	0.93	0.55	0.81	0.30	0.65	0.50	0.70	0.27	0.68	0.75	0.68	0.94	0.88	0.33	0.81	0.75	0.94
(N)	17	8	13	15	9	15	6	6	6	7	20	13	10	10	14	10	13	17	10	19	8	12	3	8	4	18

Lap	118	-	-	-	-	-	-	-	-	-	-	-	-	-	-	-	-	-	-	-	-	-	-	-	-	-	-
109	-	-	-	-	0.14	0.17	0.75	-	-	-	-	-	-	-	-	-	-	-	-	0.37	-	0.50	-	-	-	-	-
104	-	-	0.18	-	-	-	-	-	-	-	-	-	-	-	-	-	-	-	-	-	-	-	-	-	-	-	-
102	-	-	-	-	-	-	-	-	-	-	-	-	-	-	-	-	-	-	-	-	-	-	-	-	-	-	-
100	1	1	0.73	1	1	0.86	0.66	0.25	1	1	0.91	0.80	0.86	1	0.88	-	0.78	0.75	1	0.63	-	0.38	1	1	1	1	
99	-	-	0.09	-	-	0.17	-	-	-	-	0.09	0.20	0.14	-	0.12	0.75	0.22	0.19	-	1	-	-	-	-	-	-	
97	-	-	-	-	-	-	-	-	-	-	-	-	-	-	-	-	0.25	-	-	-	-	-	-	-	-	-	
(N)	12	6	11	9	1	7	3	6	1	6	11	5	7	6	8	4	9	8	4	8	1	8	2	3	1	8	

Ldh-I	105	-	-	-	-	-	-	-	-	-	-	-	-	-	-	-	-	-	-	-	-	-	-	-	-	-	-
103	-	0.06	0.06	0.03	-	0.08	-	0.25	-	-	0.03	0.29	0.28	0.25	0.54	0.39	0.10	0.29	0.31	0.03	0.31	0.33	0.50	0.25	-	0.22	
100	0.63	0.31	0.56	0.43	0.61	0.47	0.67	0.50	0.58	0.79	0.64	0.29	0.28	0.44	0.08	0.17	0.40	0.34	0.13	0.47	0.44	0.46	0.33	0.44	1	0.78	
96	0.37	0.63	0.38	0.54	0.39	0.50	0.17	0.33	0.17	0.21	0.33	0.42	0.44	0.31	0.38	0.44	0.50	0.34	0.56	0.50	0.19	0.21	0.17	0.31	-	-	

94	-	-	-	-	-	-	-	-	-	-	-	-	-	-	-	-	-	-	-	-	-	-	-	-	-	-	
(N)	12	8	8	14	9	15	6	6	6	7	18	12	9	8	12	9	5	16	8	19	8	12	3	8	4	18	
L.dh-2	105	-	-	-	-	-	-	-	-	-	-	-	-	-	-	-	0.06	-	-	-	-	-	-	-	-	-	
103	-	-	-	-	-	0.07	0.08	-	-	-	0.07	-	-	-	-	-	-	0.06	-	-	-	-	-	-	-	-	
100	0.89	1	0.17	0.93	0.72	0.50	0.75	0.50	0.25	0.75	0.78	0.72	1	1	1	0.72	1	0.28	1	0.56	0.64	0.45	0.83	0.42	-	-	
96	0.07	-	-	-	-	-	-	-	-	-	0.03	-	-	-	-	-	-	-	-	-	-	-	-	-	-	-	
94	0.04	-	0.83	0.07	0.28	0.43	0.17	0.50	0.50	0.25	0.19	0.21	-	-	-	0.22	-	0.72	-	0.38	0.36	0.41	0.17	0.58	-	-	
80	-	-	-	-	-	-	-	-	0.25	-	-	-	-	-	-	-	-	-	-	-	0.14	-	-	-	-	0.11	
72	-	-	-	-	-	-	-	-	-	-	-	-	-	-	-	-	-	-	-	-	-	-	-	-	-	1	0.89
(N)	14	7	12	14	9	14	6	6	4	4	18	7	5	5	3	9	8	16	8	16	7	11	3	6	4	13	

Mdh-1	112	-	-	-	0.03	-	-	-	-	-	-	-	-	-	-	-	-	-	-	-	-	-	-	-	-	-	0.06	
110	-	-	-	-	-	-	-	-	-	-	-	-	-	-	-	-	-	-	-	-	-	-	-	-	-	-	0.25	0.03
107	-	-	-	-	-	-	-	-	-	-	-	-	-	-	-	-	0.04	-	-	-	-	-	-	-	-	-	0.75	0.68
102	-	-	-	-	-	-	-	-	-	-	-	-	-	-	-	-	-	-	-	-	-	-	-	-	-	-	-	0.23
100	1	1	1	0.97	1	0.93	0.83	1	1	1	1	1	1	0.90	1	1	0.96	1	1	1	0.88	1	0.83	0.94	-	-	-	-
94	-	-	-	-	-	-	-	-	-	-	-	-	-	-	-	-	-	-	-	-	0.12	-	0.17	0.06	-	-	-	-

91	-	-	-	-	-	-	-	-	-	-	-	-	-	-	-	-	-	-	-								
(N)	17	8	13	15	9	14	6	6	6	6	7	19	13	10	10	14	10	13	18	10	18	8	10	3	8	4	17

Mdh-2	100	0.86	0.81	0.60	1	0.94	0.90	0.92	0.92	0.92	1	0.94	1	0.90	1	0.83	0.94	0.50	0.86	0.90	1	0.94	0.96	0.32	0.94	1	1
	99	-	-	0.15	-	0.03	-	-	-	-	-	-	-	-	-	-	-	0.17	0.03	0.05	-	-	-	0.17	-	-	-
	98	-	0.19	-	-	0.06	-	0.08	-	-	-	-	-	-	-	0.17	-	0.08	-	-	-	0.06	-	0.17	0.06	-	-
	97	0.11	-	0.10	-	0.07	-	-	-	-	-	0.06	-	0.10	-	-	-	0.25	0.03	-	-	-	-	-	-	-	-
	96	-	-	0.10	-	-	-	-	-	0.08	-	-	-	-	-	-	-	-	-	-	-	-	-	-	-	-	-
	95	-	-	0.05	-	-	-	0.08	-	-	-	-	-	-	-	-	0.06	-	-	-	-	-	0.04	0.17	-	-	
	93	-	-	-	-	-	-	-	-	-	-	-	-	-	-	-	-	-	0.05	-	-	-	-	-	-	-	
	91	0.03	-	-	-	-	-	-	-	-	-	-	-	-	-	-	-	-	0.03	0.05	-	-	-	-	-	-	
	88	-	-	-	-	-	-	-	-	-	-	-	-	-	-	-	-	-	-	-	-	-	-	0.17	-	-	
(N)	14	8	10	15	9	15	6	6	6	6	7	18	13	10	9	12	9	12	18	10	19	8	12	3	8	4	18

Me	108	-	-	-	-	-	-	-	-	-	-	-	-	-	-	-	-	-	-	-	-	-	-	-	-	-	-	0.03	
	106	-	-	-	-	-	-	-	-	-	-	-	-	-	-	-	0.31	-	-	-	-	-	-	-	-	-	-	-	-
	102	-	0.13	0.20	0.23	0.22	0.25	0.20	0.08	0.20	0.17	0.10	0.15	0.33	0.22	0.58	0.50	0.14	0.09	0.05	0.37	0.21	-	-	0.42	1	0.97		
	100	0.77	-	0.50	0.77	0.11	0.07	0.20	-	0.60	0.33	0.66	-	0.56	0.61	-	0.19	0.86	0.75	0.95	0.16	0.29	0.69	-	0.33	-	-	-	

98	0.23	0.50	0.30	-	0.67	0.64	0.60	0.92	0.10	0.33	0.24	0.81	0.11	0.17	0.42	-	0.16	-	0.47	0.50	0.31	1	0.17	-	-	
96	-	0.31	-	-	-	-	-	0.10	-	-	-	-	-	-	-	-	-	-	-	-	-	-	-	-	-	
94	-	0.06	-	-	0.04	-	-	-	-	-	0.04	-	-	-	-	-	-	-	-	-	-	-	-	-	-	
92	-	-	-	-	-	-	-	-	-	0.17	-	-	-	-	-	-	-	-	-	-	-	-	-	0.08	-	
(N)	13	8	5	13	9	14	5	6	5	6	19	13	9	9	12	8	7	16	10	19	7	8	1	6	4	18

Mpi	104	-	-	-	-	0.03	0.08	-	0.08	0.07	-	-	-	-	-	-	-	-	0.05	0.13	-	0.17	-	-	-	
	100	0.94	0.56	0.65	0.90	0.83	0.90	0.84	1	0.92	0.72	0.95	0.77	0.40	0.78	0.68	0.60	0.85	0.60	0.86	0.87	0.81	0.83	0.83	0.75	-
	97	0.06	0.44	0.35	0.10	0.17	0.07	0.08	-	0.14	0.05	0.23	0.60	0.22	0.32	0.40	0.15	0.40	0.14	0.08	0.06	0.17	-	0.25	1	0.78
	91	-	-	-	-	-	-	-	-	0.07	-	-	-	-	-	-	-	-	-	-	-	-	-	-	-	0.11
(N)	17	8	13	15	9	15	6	6	6	7	20	13	10	9	14	10	13	20	11	19	8	12	3	8	4	18

Pep	102	-	0.13	0.31	-	-	0.10	0.25	-	0.20	-	-	-	-	-	1	0.06	-	0.03	0.28	-	-	-	-	-	0.15	
	100	0.47	0.81	0.69	0.75	1	0.64	0.42	0.92	0.80	1	0.58	0.67	1	0.95	0.86	0.80	-	0.86	0.67	0.87	0.36	0.75	0.83	0.94	1	0.82
	98	0.09	0.06	-	-	-	0.23	-	0.08	-	-	0.03	0.33	-	0.14	0.20	-	0.08	-	0.10	-	0.05	0.17	0.06	-	0.03	
	96	0.44	-	-	0.25	-	0.03	0.33	-	-	-	0.39	-	-	0.05	-	-	-	0.33	-	0.36	0.20	-	-	-	-	
(N)	17	8	13	14	9	15	6	6	5	7	19	12	10	10	14	10	11	18	9	19	7	10	3	8	4	17	









loci or their zymograms were not scorable. These specimens were not included for calculations of allele frequencies at the respective loci. Therefore, the number of specimens is not always identical in Table 1 for all loci scored in a particular population. Most enzyme loci are highly polymorphic in all three taxa, viz. *Glomeris undulata*, *G. conspersa* and *G. romana*.

Although the samples of *G. undulata* and *G. conspersa* cover large parts of the ranges of these taxa, only minor variation in allele frequencies of the respective populations was observed. While *G. romana* differs from *G. undulata* and *G. conspersa* at several loci by allele substitution (Sod-1) or highly different allele frequencies (Aat-1, Gapdh, Ldh-2, Mdh-1, Mpi, Pgm, Sodh), *G. undulata* and *G. conspersa*, in contrast, usually show the same alleles and very similar frequencies. The analysis of the distribution of rare alleles reveals that some local alleles which were each found at one locality only, are present in both *G. undulata* and *G. conspersa* from the particular locality. These local alleles are: Aat-2<sup>96</sup> in the Merishausen sample, allele Me<sup>92</sup> at Meride, allele Ldh-2<sup>96</sup> at Ehingen, allele Ldh-2<sup>80</sup> at Malans and allele Sodh<sup>86</sup> at Meride.

The UPGMA dendrogram that resulted from a cluster analysis of the populations according to their genetic distances is shown in Fig. 2. *G. romana* is clearly separated from the other two taxa with an average genetic distance (Nei-D) of 0.65 and a bootstrap value of 100. *G. undulata* and *G. conspersa*, in contrast, do not form separate clusters. The syntopic samples are of particular interest because in seven from eight such situations studied, *G. undulata* and *G. conspersa* from the same locality cluster with lowest genetic distances, and four of these clusters are supported by bootstrap values > 70 (Fig. 2). Genetic distances among the *undulata/conspersa* populations are rather low. Thus, separations of the samples according to geographical regions or differentiations according to geographical distances are not evident.

## DISCUSSION

Several species of the genus *Glomeris* are known to be highly variable in their colour pattern, and about 400 varieties, including the nominotypic varieties, have been described which belong to about 70 nominal species (many names, however, are not available according ICZN Art. 16 + 45f, g). If the biological species concept (e.g. MAYR & ASHLOCK 1991) is applied that defines species as genetic units of naturally interbreeding populations which are reproductively isolated from other such groups, allozyme data provide a very powerful tool to test whether or not two taxa or forms share a common gene pool and thus belong to the same species. Species boundaries and specific separation within the genus *Glomeris* have recently been successfully analysed with allozyme data (HOESS *et al.* 1997) where *G. intermedia* Latzel, 1884, was shown to be a separate species, contrary to traditional taxonomy that treated *G. intermedia* as a subspecies of *G. hexasticha* Brandt, 1833.

*G. undulata* and *G. conspersa* have always been treated as two distinct species which are assumed to be closely related. Intermediate forms that might indicate hybrids have not been observed even though both taxa are often found syntopic and

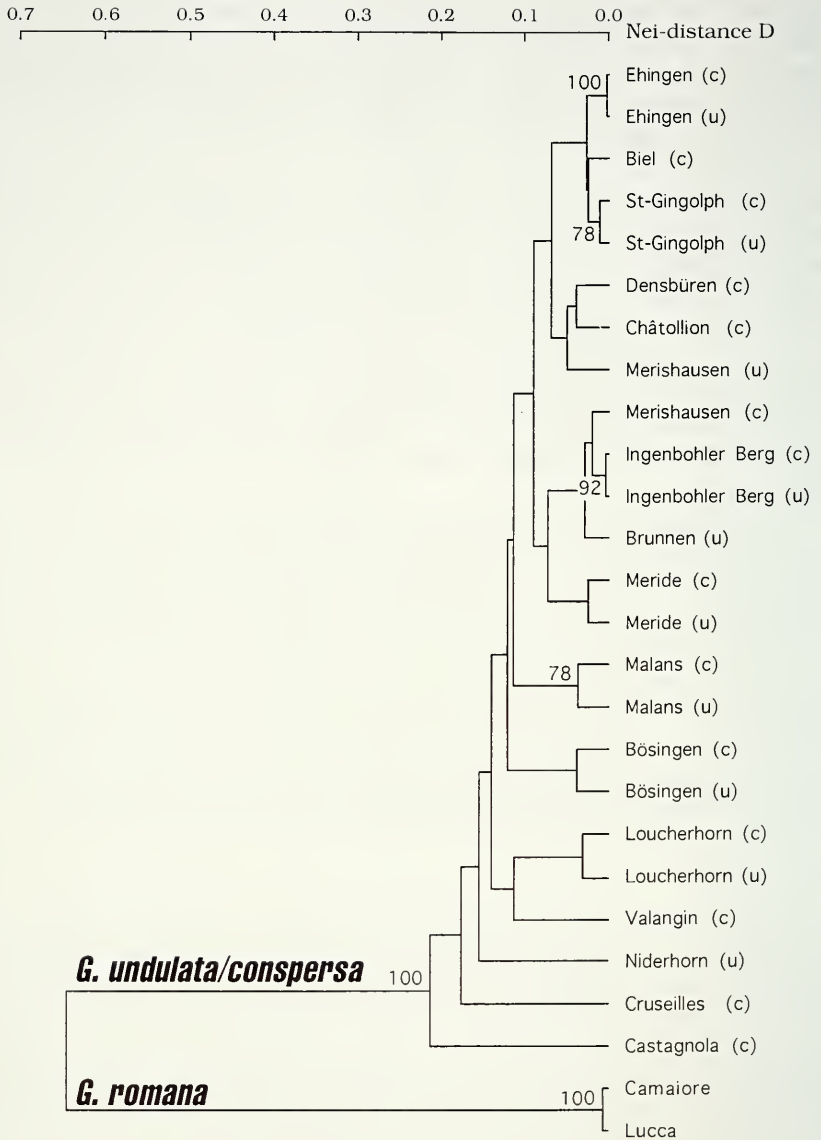

FIG. 2

UPGMA dendrogram based on Nei-distance D values in pairwise comparisons of populations of *Glomeris undulata* (u), *G. conspersa* (c) and *G. romana*. Bootstrap values > 70 are indicated (percentage over 100 replicates).

large parts of their ranges overlap. Only VERHOEFF (1901) described a light form of *G. undulata* as var. *pseudoconspersa* indicating to him a mixture of the colour pattern of both taxa, and, later, postulated some hybrids (VERHOEFF 1928b, p. 320-321). Thus, as judged from the colour patterns, specific separation of *G. undulata* and *G. conspersa* seems to be completed despite some rare possible hybrids. The genetic basis of variation in colour patterns, however, has never been analysed in *Glomeris*. The difference in the colour patterns of *G. undulata* and *G. conspersa* might result from two alleles in a dominant/recessive relation at a single locus. In this case, we would not expect to find intermediate forms.

#### ALLOZYME DATA

Based on the allozyme data, there is no evidence for separate gene pools of *G. undulata* and *G. conspersa*. The alleles observed and their frequencies are rather similar in all populations of both taxa. Consequently, the degree of genetic differentiation of all populations studied is very low. Furthermore, the analysis of the distribution of rare alleles is very informative because it revealed that local alleles (cf. BUSACK 1986) are repeatedly found in syntopic populations of both taxa. The Aat-2 locus is of particular interest because this locus is highly conservative in *Glomeris* (HOESS *et al.* unpublished), most *Glomeris* species are fixed for the allele Aat-2<sup>100</sup>, and allele Aat-2<sup>96</sup> is only found at the locality Merishausen where it was recorded in both *G. undulata* and *G. conspersa*.

In the dendrogram, the populations of *G. undulata* and *G. conspersa* do not form separate clusters, but syntopic populations of both taxa usually cluster at lowest levels of genetic differentiation, and most of these clusters are supported by bootstrap values > 70. Consequently, we regard the taxa *G. undulata* and *G. conspersa* as a single species (see "Conclusion" below) and treat *conspersa* in the following as a form of *G. undulata*. In comparison to *G. undulata/conspersa*, *G. romana* clearly has a separate gene pool. Genetic differentiation, however, is rather low. This agrees with current classification where *G. romana* is assumed to be closely related to *G. undulata/conspersa* (VERHOEFF 1911).

#### COLOUR PATTERN

Although both forms of *G. undulata* (n nominate form and f. *conspersa*) are often found syntopically, no transition in colour pattern is known. In fact, *G. undulata* var. *pseudoconspersa* and the "hybrids" of VERHOEFF (1928b) do not represent transition forms at the dorsal spots, that means from the parallel spots of *undulata* to the convergent spots of *conspersa*. Instead, VERHOEFF (1928b) used the colour pattern of the remaining parts of the tergites to qualify these specimens as transitional. Consequently, the question remains: why are the two forms of *G. undulata* separated so strictly?

A specially patterned *G. undulata* specimen (from near Mendrisio in Ticino, Switzerland) may help to understand the real nature of the colour pattern of *G. undulata*. The fifth tergite of this specimen is illustrated in Fig. 3a. Unlike most individuals of this species where the speckles seem to be scattered irregularly next to the central spot, the speckles of this specimen are arranged in a sinuous line that strikingly

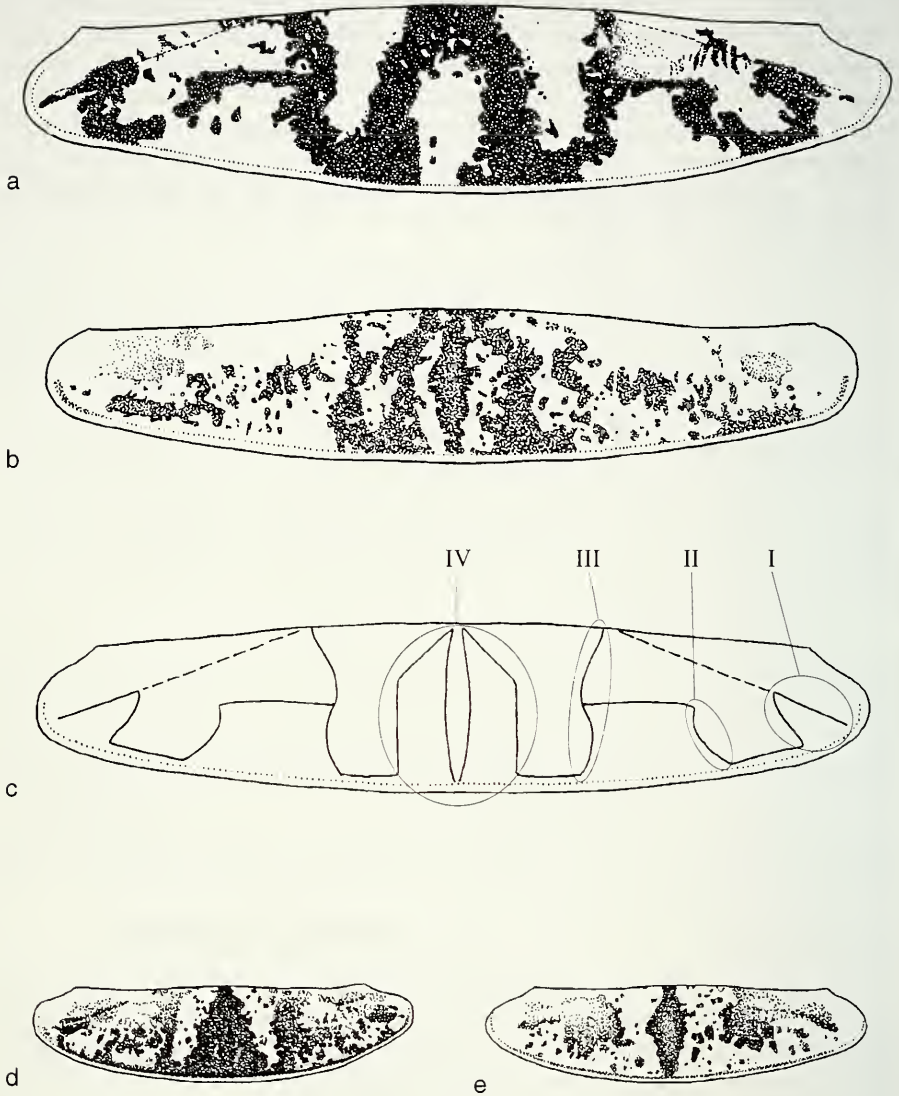

FIG. 3

Vertical view of the fifth tergite of *Glomeris undulata*: a) a specimen from Mendrisio (Switzerland), b) a specimen from Ingenboehler Berg (Switzerland), c) schematic diagram of the basic pattern of *G. undulata* (sinuous line) with the nomenclature of the dark spots sensu VERHOEFF (1928a), d) "normally coloured" specimen of nominate form, e) "normally coloured" specimen of *f. conspersa*.

resembles the dark spots of many other *Glomeris* species. Possibly, this specimen reflects the original pattern of *G. undulata*. Varieties with a light spot IV (sensu VERHOEFF 1928a) between the dark spots IV (as in the illustrated specimen) are already known. But this pattern cannot explain the difference in the central dark spot between the nominate form and f. *conspersa*. However, other varieties are known - e.g. the specimen shown in Fig. 3b (from Ingenbohrer Berg) - that show an additional dark spot in the light spot IV. From these two specimens we can conclude a basic pattern for the species which is illustrated in Fig. 3c. The sinuous line (with an extra line in the region of the muscular insertions on the prozonite) may be traced from one side to the other. In real specimens, certain parts of this sinuous line may be invisible due to non-expression of the dark pigment or they may be connected by dark pigment filling up the space between the dark spots. Thus, we can conclude that in the nominate form of *G. undulata* the dark spots IV are well expressed and normally connected, and that in f. *conspersa* only the dark spot within the light spot IV - in Verhoeff's terminology this dark spot was treated as part of the dark spots IV - is well expressed and the normal dark spots IV are missing. With this argumentation no transition between the nominate form of *G. undulata* (Fig. 3d) and the form *conspersa* (Fig. 3e) can be imagined. A single gene or a group of coupled genes may be responsible for the expression or absence of the dark spots IV.

#### DISTRIBUTION

Fig. 4 shows the distribution of *G. undulata* (nominate form and f. *conspersa*) based on a compilation of literature data and on own collections. In large parts of its range, *G. undulata* is present only in one form. The reasons for this situation are not known. But if the above hypothesis of the genetic basis of the two forms would be confirmed experimentally, the discordant distribution of both forms could be explained by local differences in allele frequencies, either due to selection or stochastic processes.

#### CONCLUSION

As we have shown, there is no evidence for separate gene pools in syntopic populations of *Glomeris undulata* and *G. conspersa*. Thus, we conclude that these taxa are conspecific. Therefore, we consider *G. conspersa* C.L.Koch, 1847, as a junior subjective synonym of *G. undulata* C.L.Koch, 1844 (**nov. syn.**). There is no need to preserve the better known name *G. conspersa* because *G. undulata* has been used many times in the literature (at least 37 entries for *G. undulata* and at least 69 entries for *G. conspersa*).

#### ACKNOWLEDGEMENTS

We thank L. Beer, L. Frauchiger and V. Siegfried for assisting in the laboratory work. P. Benninger, M. Braunwalder, B. Gantenbein, R. Köpfli, M. Lörtscher, S. Minder, A. Pedrolì-Christen, A. Schuppisser and P. Sonderegger helped us gather the glomerids used in this study. E. Obrecht made valuable comments on an earlier draft of the manuscript.

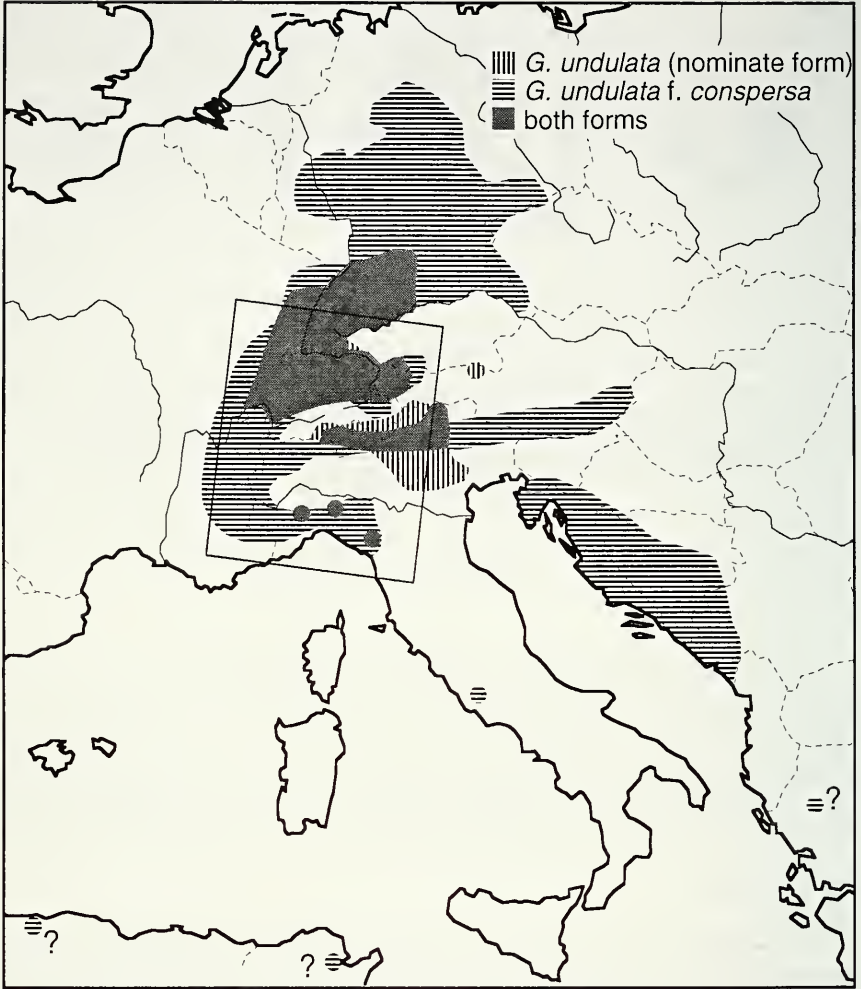

FIG. 4

Distribution of *Glomeris undulata* (nominate form and f. *conspersa*). The section covered in Fig. 1 is framed.

REFERENCES

BUSACK, S. D. 1986. Biogeographic analysis of the herpetofauna separated by the formation of the Strait of Gibraltar. *National Geographic Research* 2: 17-36.

FELSENSTEIN, J. 1986-95. PHYLIP (Phylogeny Inference Package), version 3.5c, native-mode executables for PowerMac. *Univ. Washington*.

HOESS, R., SCHOLL, A. & LÖRTSCHER, M. 1997. The *Glomeris*-taxa *hexasticha* Brandt and *intermedia* Latzel: species or subspecies? - allozyme data (Diplopoda, Glomerida, Glomeridae). *Eutomologica Scandinavica, Supplement* 51: 133-138.

- INTERNATIONAL COMMISSION ON ZOOLOGICAL NOMENCLATURE 1985. International code of zoological nomenclature - 3rd edition. *Charlesworth, Huddersfield*, XX + 338 pp.
- KOCH, C. L. 1844. Deutschlands Crustaceen, Myriapoden und Arachniden. *In: Deutschlands Insecten ... fortgesetzt von G. A. W. HERRICH-SCHÄFFER*, Heft 40 (= G. W. F. PANZER, *Fauna Insectorum Germanicae initia*, Heft 190). *Pustet, Regensburg*.
- KOCH, C. L. 1847. System der Myriapoden, mit den Verzeichnissen und Berichtigungen zu Deutschlands Crustaceen, Myriapoden und Arachniden. Heft 1-40. *F. Pustet, Regensburg*, V + 272 pp.
- MAYR, E. & ASHLOCK, P. D. 1991. Principles of systematic zoology - 2nd edition. *Mc Graw Hill*, New York, XX + 475 pp.
- NEI, M. 1978. Estimation of average heterozygosity and genetic distance from a small number of individuals. *Genetics* 89: 583-590.
- SCHOLL, A., CORZILLIUS B. & VILLWOCK, W. 1978. Beitrag zur Verwandtschaftsanalyse altweltlicher Zahnkarpfen der Tribus Aphaniini (Pisces, Cyprinodontidae) mit Hilfe elektrophoretischer Untersuchungsmethoden. *Zeitschrift für zoologische Systematik und Evolutionsforschung* 16: 116-132.
- SNEATH, P. H. A. & SOKAL, R. R. 1973. Numerical Taxonomy. *Freeman, San Francisco*, XV + 573 pp.
- SWOFFORD, D. L. & SELANDER, R. B. 1989. BIOSYS-1. A computer program for the analysis of allelic variation in population genetics and biochemical systematics. Release 1.7., *D. L. Swofford, Illinois Natural History Survey*.
- VERHOEFF, K. W. 1901. Beiträge zur Kenntnis palaearktischer Myriopoden. XVIII. Aufsatz: Über Diplopoden aus Süddeutschland und Tirol. *Jahresheft des Vereins für vaterländische Naturkunde in Württemberg* 57: 81-111.
- VERHOEFF, K. W. 1911. Über Diplopoden. 20. (40.) Aufsatz: Neuer Beitrag zur Kenntnis der Gattung *Glomeris*. *Jahresheft des Vereins für vaterländische Naturkunde in Württemberg* 67: 78-147.
- VERHOEFF, K. W. 1928a. Klasse Diplopoda. *In: Bronns Klassen und Ordnungen des Tier-Reichs*, 5, II. Abtl., 1. Teil, 1.-6. Lieferung. *Akademische Verlagsgesellschaft, Leipzig*: XI + 1071 pp.
- VERHOEFF, K. W. 1928b. Neue und besonders ostalpine Chilognathen-Beiträge. (108. Diplopoden-Aufsatz). *Zoologisches Jahrbuch für Systematik* 55: 253-328.
- ZIMMERMANN, M. & SCHOLL, A. 1993. Specific status of *Aquarius cinereus* (Puton) and *A. najas* (De Geer) (Hemiptera: Gerridae) and the extent of hybridisation in the Mediterranean region. *Entomologica Scandinavica* 24: 197-210.





## **Aleocharinae di Hong Kong (Coleoptera, Staphylinidae)\***

Roberto PACE

Via Vittorio Veneto 13; I-37032 Monteforte d'Alpone (Verona), Italia.

**Aleocharinae from Hong Kong (Coleoptera, Staphylinidae).** - In this paper, based on the study of new material collected by means of modern sampling methods 22 species are described as new. These new species belong to following tribes: Deinopsini (1 n. sp.), Pronomaeini (2), Gyrophaenini (2), Placusini (1), Homalotini (1), Deremini (1), Athetini (10), Pygostenini (1), Termitopaediini (1) and Myrmedoniini (2). Two new synonymies are proposed. The main diagnostic characters are illustrated.

**Key-words:** Coleoptera - Staphylinidae - Aleocharinae - taxonomy - new species - Hong Kong.

### INTRODUZIONE

Fino ad ora le specie della sottofamiglia Aleocharinae segnalate per Hong Kong città e suo territorio circostante, sono state raccolte occasionalmente e in modo sporadico. Al fine di una loro conoscenza il più possibile completa, erano necessarie ricerche mirate e l'adozione di tecniche di raccolta nuove. Così è stato effettuato dal collega Guillaume de Rougemont, noto studioso di Staphylinidae di Londra, che grazie ai suoi lunghissimi soggiorni a Hong Kong al fine di perfezionare il suo apprendimento della lingua cinese, ha curato anche la ricerca di Aleocharinae su tutto il territorio di Hong Kong. Per questo fine ha adottato varie tecniche di ricerca e ha scelto tra l'altro, come campo delle sue indagini, un'oasi naturalistica di Hong Kong, quale il "Kadoorie Agricultural Research Centre", legato all'Università di Hong Kong e proprietà dei fratelli Kadoorie, noti benefattori della città.

L'intera serie di Aleocharinae raccolte da G. de Rougemont durante il suo lungo soggiorno a Hong Kong, sono state a me affidate in studio, insieme a piccole raccolte effettuate da altri entomologi inglesi, quali S.J. Reels e G. Ades. I risultati di questo esame sono il contenuto del presente lavoro.

Gli holotypi delle nuove specie sono conservati al "Muséum d'histoire naturelle" di Ginevra (MHNG).

---

\* (151° contributo alla conoscenza delle Aleocharinae)

Manoscritto accettato il 13.02.1999

## ELENCO SISTEMATICO DELLE TRIBÙ E DELLE SPECIE

## DEINOPSINI Sharp, 1883

*Adinopsis chinensis* sp. n. (figg. 1-4)

## PRONOMAENINI Ganglbauer, 1894 (=Myllaenini)

*Myllaena hongkongiphila* sp. n. (figg. 5-6)

*Myllaena reelsi* sp. n. (figg. 7-8)

## GYROPHAENINI Kraatz, 1856

*Gyrophaena* (s. str.) *anguli* sp. n. (figg. 9-12)

*Pseudobrachida hongkongensis* sp. n. (figg. 13-14)

## PLACUSINI Mulsant &amp; Rey, 1871

*Placusa kadooriorum* sp. n. (figg. 15-19)

## HOMALOTINI Heer, 1839

*Coenonica javana* Bernhauer, 1914

*Coenonica javana* Bernhauer, 1914: 106

1 ♂, Hong Kong, Shek Kong, 20.III.1991, G. Ades leg.; 1 ♀, Hong Kong, Kadoorie Agricultural Research Centre, flight interception trap, X-XII.1996, G. de Rougemont leg.; 1 ♂, Hong Kong, Lantau Is., 8.II.1997, G. de Rougemont leg.

Distribuzione. Giava, Cina e Hong Kong.

*Anomognathus* (s. str.) *bohaci* Pace, 1992

*Anomognathus* (s. str.) *bohaci* Pace, 1992: 126

1 ♀, Hong Kong N.T., sifted litter, 1.II.1997, G. de Rougemont leg.

Distribuzione. Thailandia. Nuova per Hong Kong.

*Linoglossa* (s. str.) *hongkongensis* sp. n. (figg. 20-22)

## DEREMINI Seevers, 1965

*Deuerinda rougemonti* sp. n. (figg. 23-24)

## ATHETINI Casey, 1910

*Hydrosmeeta subalgarum* sp. n. (figg. 25-29)

*Atheta* (*Acrotona*) *iperanomala* sp. n. (figg. 30-32)

*Atheta* (*Acrotona*) *shekkongensis* sp. n. (figg. 33-36)

*Atheta* (*Acrotona*) *tricholutea* sp. n. (figg. 37-38)

*Atheta* (*Coprothassa*) *roridanotha* sp. n. (figg. 39-42)

*Atheta* (*Microdota*) *vagans* Bernhauer, 1907

*Atheta* (*Microdota*) *vagans* Bernhauer, 1907: 404; PACE 1998: 150.

*Atheta* (*Microdota*) *tronquetiella* Pace, 1988: 328. **syn. n.**

1 ♂ e 2 ♀, Hong Kong, Tsinfai Tong, 25.IV.1997, G.T. Reels leg.

Distribuzione. Sri Lanka, Taiwan, Giappone, Cina.

*Atheta (Microdota) ocellaris* Cameron, 1939 (figg. 43-46)

*Atheta (Microdota) ocellaris* Cameron, 1939: 327

*Atheta (Microdota) triflexa* Pace, 1986: 196, **syn. n.**

1 ♂, Hong Kong, C.U.R.K., flight interception trap, III-IV.1997, G. de Rouge-  
mont leg.

Distribuzione. India, Giava, Hong Kong.

*Atheta (Microdota) pseudovagans* sp. n. (figg. 47-50)

*Atheta (Microdota) persimplex* sp. n. (figg. 51-54)

*Atheta (Poromicrodota) hoihaensis* sp. n. (figg. 55-56)

*Atheta (Sipalatheta) algarum* sp. n. (figg. 59-62)

*Tomoglossa fuliginosa* sp. n. (figg. 63-64)

*Pelioptera opaca* Kraatz, 1857

*Pelioptera opaca* Kraatz, 1857: 56; PACE 1998: 152

1 ♀, Hong Kong, Kao Tam Tso, yellow pan, 18.V.1986, G.T. Reels leg.

Distribuzione. Sri Lanka, Nepal, India, Birmania, Cina, Hong Kong, Sabah,  
Giappone.

PYGOSTENINI Fauvel, 1899

*Odontoxenus reelsi* sp. n. (figg. 65-66)

TERMITOPAEDIINI Seevers, 1957

*Dioxeuta rougemonti* sp. n. (figg. 67-69)

MYRMEDONIINI Thomson, 1867

*Zyras (Sinozyras* subgen. n.) *pygmaeus* sp. n. (figg. 70-73)

*Zyras (Zyras) hongkongensis* sp. n. (figg. 74-77)

*Zyras (Glossacantha) yangi* Bernhauer, 1938

*Zyras (Glossacantha) yangi* Bernhauer, 1938: 147

1 ♀, Hong Kong, Shek Kong, at light, 19.III.1992, G. Ades leg.

Distribuzione. Cina. Nuova per Hong Kong.

Nota. Il bulbo distale della spermateca dell'esemplare di Hong Kong è netta-  
mente più lungo di quello della spermateca dei tipi di *yangi*.

## DESCRIZIONI

DEINOPSINI Sharp, 1883

**Adinopsis chinensis** sp. n.

Figg. 1-4

Holotypus ♀, Hong Kong, X-XII.1996, G. de Rougemont leg. (MHNG).

DESCRIZIONE. Lunghezza 2,0 mm. Corpo debolmente opaco e giallo-bruno con capo bruno e margine anteriore et posteriore del pronoto gialli; antenne gialle, zampe rossicce. L'intera superficie del corpo è coperta di tubercoletti estremamente superficiali e di pubescenza sericea fittissima; spermateca fig. 2, urotergite X della femmina con due valvule fig. 3, apice dello stesso fig. 4.

COMPARAZIONI. La nuova specie è affine ad *A. rufobrunnea* Cameron, 1919, di Singapore e ad *A. nepalensis* Pace, 1987, a motivo della presenza della papilla molto stretta all'apice dell'undicesimo antennumero. Se ne distingue per i caratteri dati nella seguente chiave:

- |   |   |                            |
|---|---|----------------------------|
| 1 | Lunghezza 1,8 mm; rapporto larghezza/lunghezza del pronoto pari a 1,45 o 1,60; femmina sconosciuta . . . . .  | 2                          |
| - | Lunghezza 2,0 mm; rapporto larghezza/lunghezza del pronoto pari a 1,30; maschio sconosciuto. Hong Kong. . . . .   | <i>chinensis</i> sp. n.    |
| 2 | Rapporto larghezza/lunghezza del pronoto pari a 1,60; apice dell'edeago appuntito e armatura genitale interna dell'edeago semplice. Singapore . . . . .       | <i>rufobrunnea</i> Cameron |
| - | Rapporto larghezza/lunghezza del pronoto pari a 1,45; apice dell'edeago non appuntito e armatura genitale interna dell'edeago ben sviluppata. Nepal . . . . . | <i>nepalensis</i> Pace     |

PRONOMAEINI Ganglbauer, 1895 (=Myllaenini)

**Myllaena hongkongiphila** sp. n.

Figg. 5-6

Holotypus ♀, Hong Kong, Kadoorie Agricultural Research Centre, flight interception trap, X-XII.1996. G. de Rougemont leg. (MHNG).

DESCRIZIONE. Lunghezza 2,2 mm. Corpo debolmente lucido e giallo sporco (immaturato); antenne gialle con i tre antennumeri basali giallo sporco; zampe gialle. L'intero corpo è coperto di pubescenza sericea fittissima; spermateca fig. 6.

COMPARAZIONI. La nuova specie presenta parte prossimale della spermateca non avvolta a spirale. Per questo carattere la specie tassonomicamente e geograficamente più vicina è *M. himalayca* Cameron, 1939, dell'India settentrionale. Ma la spermateca di quest'ultima specie ha bulbo distale assai stretto, con introflessione apicale minuscola, e non larghissima come quella della nuova specie. Inoltre la nuova specie mostra occhi più lunghi delle tempie, mentre *himalayca* li ha più corti delle tempie.

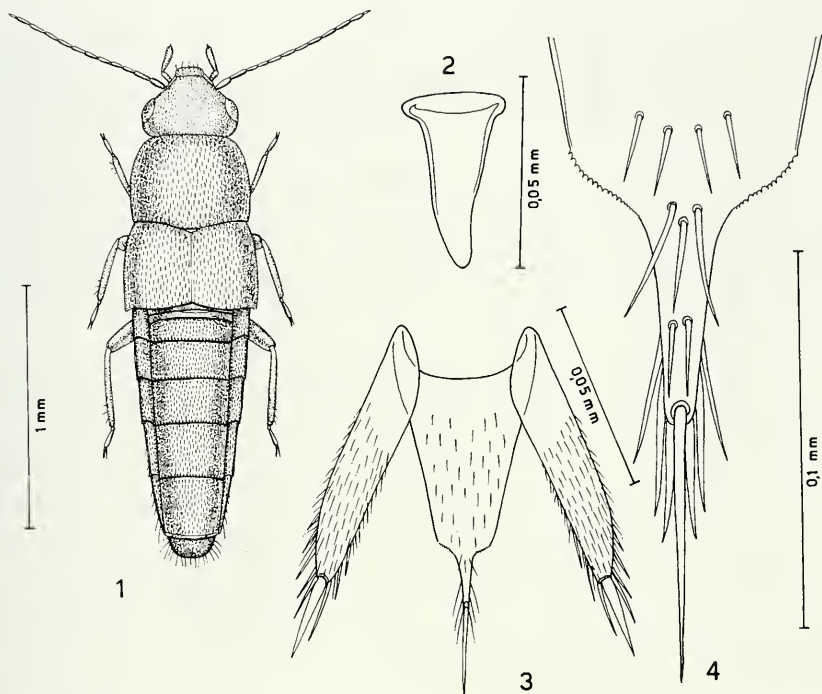

FIGG. 1-4

*Adinopsis chinensis* sp. n. Habitus: 1; spermateca: 2; urotergo della femmina con due valve: 3; apice dello stesso: 4.

***Myllaena reelsi* sp. n.**

Figg. 7-8

Holotypus ♀, Hong Kong, Ma On Shan, at light, 17.X.1996, G.T. Reels leg. (MHNG).

DESCRIZIONE. Lungh. 3,7 mm. Corpo debolmente lucido e giallo-bruno; antenne brune con antennumero basale giallo sporco e undicesimo giallo paglierino; zampe giallo sporco. L'intera superficie del corpo è coperta di pubescenza sericea fittissima; spermateca fig. 8.

COMPARAZIONI. La nuova specie presenta la parte prossimale della spermateca che descrive due spire. Per questo carattere va comparata con *M. chinoculata* Pace, 1998, della Cina. Ma questa specie presenta tali spire relativamente più ampie, taglia corporea nettamente inferiore (1,9 mm), occhi molto più corti delle tempie ed elitre più corte del pronoto.

ETIMOLOGIA. La nuova specie è dedicata al suo raccogliitore Graham Reels, entomologo inglese.

## GYROPHAENINI Kraatz, 1856

**Gyrophaena (Gyrophaena) anguli** sp. n.

Figg. 9-12

Holotypus ♂, Hong Kong, sifted litter, 1.II.1997, G. de Rougemont leg. (MHNG).

Paratypus: 1 ♀, Hong Kong, Kadoorie Agricultural Research Centre, X-XII.1996, G. de Rougemont leg.

DESCRIZIONE. Lungh. 1,7 mm. Corpo lucido e bruno con addome giallo avente gli uroterghi liberi IV e V nero-bruni; antenne e zampe gialle. La punteggiatura del capo e del pronoto è netta e distribuita come da fig. 11. Le elitre sono coperte di tubercolotti superficiali. Solo il quinto urotergo libero presenta reticolazione, ma superficiale: sul resto del corpo la reticolazione è assente. Edeago figg. 9-10, sesto urotergo libero del maschio fig. 12.

COMPARAZIONI. La nuova specie presenta due caratteri che permettono di avvicinarla tassonomicamente a *G. gratella* Cameron, 1939, dell'India: il margine posteriore del sesto urotergo libero del maschio con quattro denti, di cui i due interni più esili degli esterni e apice dell'edeago flesso al lato ventrale e senza appendice preapicale. Tuttavia i denti laterali del sesto urotergo libero del maschio di *gratella* sono stretti alla base e lunghi il doppio degli interni, mentre gli interni della nuova specie sono lunghi meno del doppio degli esterni. Inoltre l'apice dell'edeago della nuova specie, in visione laterale, è stretto, mentre è assai largo in *gratella*. Il pronoto di *gratella* ha doppia punteggiatura, cioè fine e sparsa tra i quattro punti discali in quadrato, mentre il pronoto della nuova specie ha solo punti isolati robusti.

**Pseudobrachida hongkongensis** sp. n.

Figg. 13-14

Holotypus ♀. Hong Kong, Kadoorie Agricultural Research Centre, 31.V.1996, G. de Rougemont leg. (MHNG).

DESCRIZIONE. Lungh. 1,6 mm. Corpo lucidissimo e bruno con margine posteriore degli uroterghi rossiccio; antenne giallo sporco con antennomeri 8 a 10 giallo-bruni e undicesimo bruno; zampe gialle. Solo le elitre sono coperte di reticolazione distinta, il resto del corpo è senza reticolazione. La punteggiatura del capo e del pronoto è evidente e distribuita come da fig. 13. Gli uroterghi sono coperti di tubercoli allungati; spermateca fig. 14.

COMPARAZIONI. Dato che presenta il penultimo antennumero fortemente trasverso, la nuova specie sembra simile a *P. siwalikensis* Cameron, 1939, dell'India. Ma questa specie presenta addome bruno-rossiccio, con fascia nericia davanti al pigidio, il quinto urotergo libero senza tubercoli e taglia corporea di 2,3 mm.

## PLACUSINI Mulsant &amp; Rey, 1871

**Placusa kadooriorum** sp. n.

Figg. 15-19

Holotypus ♂, Hong Kong, Kadoorie Agricultural Research Centre. flight interception trap, X-XII.1996, G. de Rougemont (MHNG).

Paratypus: 1 ♀, Hong Kong N.T., sifted litter. 1.II.1997, G. de Rougemont leg.

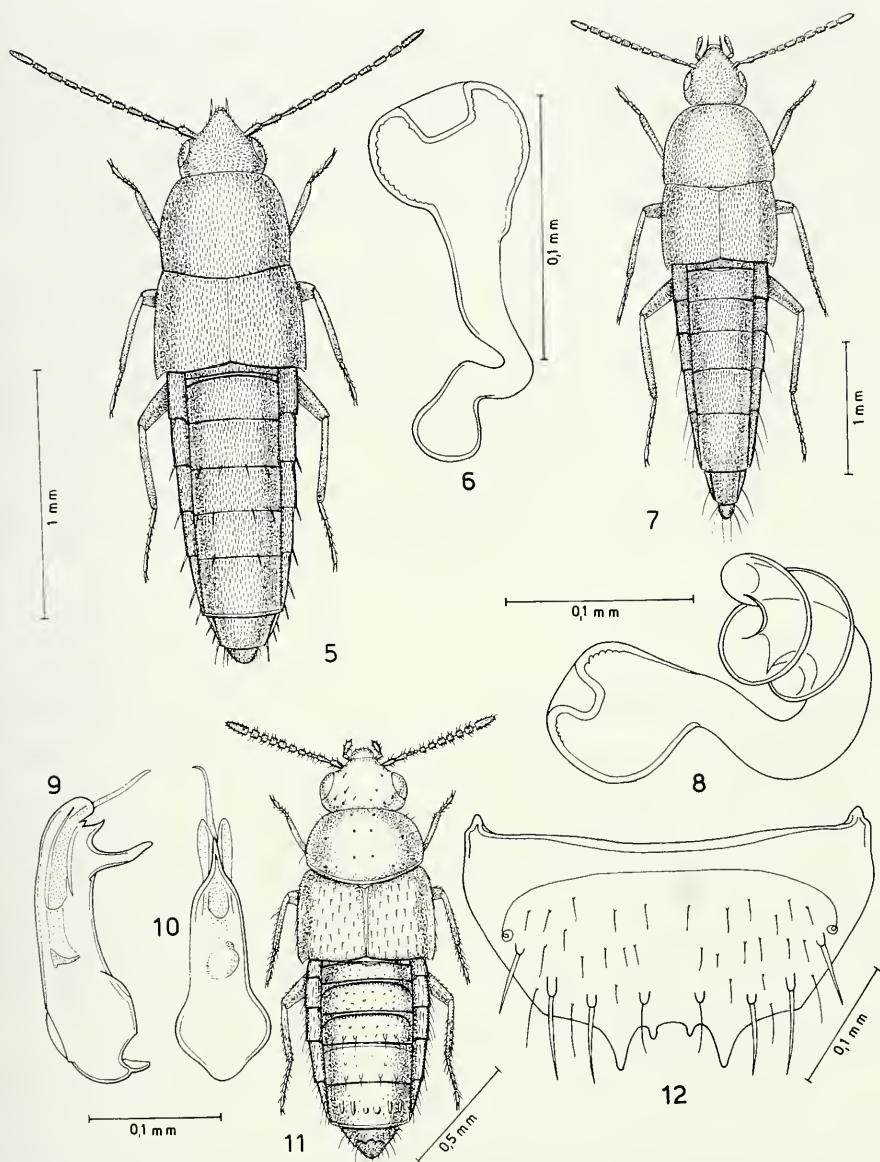

FIGG. 5-12

Habitus, spermateca, edeago in visione laterale e ventrale e sesto urotergo libero del maschio.  
 5-6: *Myllaena hongkongiphila* sp. n.; 7-8: *Myllaena reelsi* sp. n.; 9-12: *Gyrophaena (Gyrophaena) anguli* sp. n.

DESCRIZIONE. Lungh. 1,8 mm. Corpo lucido e nero-bruno con metà posteriore delle elitre di un giallo sporco e con il margine posteriore degli uroterghi rossiccio; antenne nere con i quattro antennomeri basali giallo paglierino; zampe giallo-rossicce con femori bruni. La reticolazione del capo è distinta, quella del pronoto è estremamente superficiale e quella delle elitre e dell'addome è svanita. La punteggiatura del capo è distinta. Il pronoto, le elitre e l'addome sono coperti di tubercoletti superficiali. Il pronoto ha quattro punti isolati profondi; edeago figg. 16-17, spermateca fig. 18, sesto urotergo libero del maschio fig. 19.

COMPARAZIONI. In base alla forma dell'edeago, la nuova specie mostra d'essere tassonomicamente affine a *P. pygmaea* Kraatz, 1859, dello Sri Lanka, ma i denti del margine posteriore del sesto urotergo libero del maschio, sono assai differenti, cioè in *pygmaea* vi è un largo dente mediano ad apice arrotondato tra due spine laterali ricurve. Anche l'edeago delle due specie presenta differenze sensibili. Il dente preapicale ventrale dell'apice della lama sternale dell'edeago di *pygmaea*, è molto vicino all'apice, e piuttosto distante è quello della nuova specie.

ETIMOLOGIA. La nuova specie è dedicata ai fratelli Kadoorie, noti benefattori di Hong Kong. Essi hanno concesso a G. de Rougemont di effettuare ricerche sulle Aleocharinae nel loro Centro di Ricerca sull'Agricoltura.

#### HOMALOTINI Heer, 1839

#### *Linoglossa* (s. str.) *hongkongensis* sp. n.

Figg. 20-22

Holotypus ♀, Hong Kong, Lantau Tai O, in *Auricularia* fungus. 15.II.1997, G. de Rougemont leg. (MHNG).

DESCRIZIONE. Lungh. 3,0 mm. Corpo lucidissimo e rossiccio con i tre uriti basali giallo-rossicci; antenne bruno-rossicce con i due antennomeri basali e l'undicesimo giallo-rossicci; zampe gialle. Sul corpo non vi è traccia di reticolazione. La punteggiatura del capo e del pronoto è fitta e molto superficiale. Sulle elitre sono sparsi alcuni punti netti su una superficie indistintamente punteggiata. Tubercoletti fini coprono la superficie degli uroterghi. La fronte è impressa trasversalmente. Il pronoto ha una profonda concavità mediana posteriore con superficie rugosa sulla linea mediana; spermateca fig. 20; sesto urotergo libero della femmina fig. 21.

COMPARAZIONI. Recente è la descrizione di una nuova specie del genere *Linoglossa* Kraatz, 1859, della Cina: *L. chinensis* Pace, 1998, ma la nuova specie presenta caratteri più simili a quelli osservabili su *L. angustata* (Motschulsky, 1858), dell'India meridionale, pertanto geograficamente più lontana, tanto che non appartiene neanche al medesimo sottogenere (sottogenere *Axinocolya* per *L. chinensis*).

La nuova specie, che presenta una fossetta del pronoto simile, è distinta da *L. angustata* per i caratteri dati nella seguente chiave:

- Decimo antennomero appena trasverso; disco del capo profondamente solcato; pronoto nettamente trasverso; bulbo distale della spermateca tronco-conico. Lungh. 3,5 mm. India meridionale. . . . *angustata* (Motschulsky)



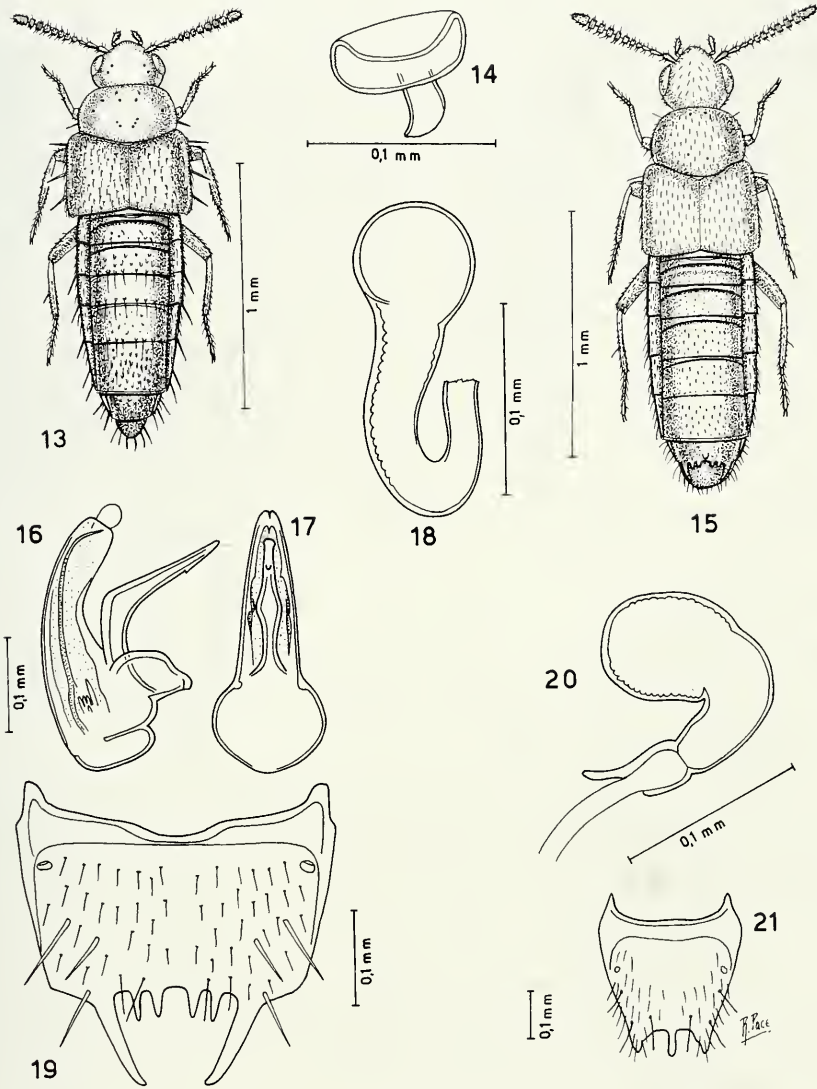

FIGG. 13-21

Habitus, spermatheca, edeago in visione laterale e ventrale e sesto urotergo libero del maschio (19) e della femmina (21). 13-14: *Pseudobrachida hongkongensis* sp. n.; 15-19: *Placusa kadooriorum* sp. n.; 20-21: *Linoglossa hongkongensis* sp. n.

- Decimo antennomero nettamente trasverso; disco del capo senza solco; pronoto quasi lungo quanto largo; bulbo distale della spermatheca subelittico. Lungh. 3,0 mm. Hong Kong. . . . . *hongkongensis* sp. n.

DEREMINI Seevers, 1965

**Demerinda rougemonti** sp. n.

Figg. 23-24

Holotypus ♀, Hong Kong N.T., sifted litter, 1.11.1997, G. de Rougemont leg. (MHNG).

DESCRIZIONE. Lungh. 1,7 mm. Corpo lucido e giallo-rossiccio con capo bruno-rossiccio e pronoto rossiccio; antenne bruno-rossicce con i tre antennomeri basali rossicci; zampe gialle. Sul corpo non vi è reticolazione. La punteggiatura del capo e del pronoto è fitta e distinta. Tuberoletti salienti coprono la superficie delle elitre e dell'addome. Il solco laterale del pronoto è profondo e largo, quello mediano è poco profondo. Le elitre presentano un debole spigolo laterale, dall'omero fino presso l'angolo posteriore esterno; spermateca assai minuscola. fig. 24.

COMPARAZIONI. In base alla forma della spermateca, la nuova specie si situa tassonomicamente lontano sia da *D. termophila* Cameron, 1924, dell'India, che da *D. hongkongensis* Pace, 1998a, di Hong Kong. Infatti queste due specie hanno spermateca ben sviluppata in lunghezza, mentre la nuova specie ha spermateca assai corta. Inoltre l'addome della nuova specie ha pubescenza rada, mentre è fitta quella dell'addome delle due specie citate a paragone.

ATHETINI Casey, 1910

**Hydrosmeeta subalgarum** sp. n.

Figg. 25-29

Holotypus ♂, Hong Kong, Tai Long, under seaweed on sand, 30.III.1997, G. de Rougemont leg. (MHNG).

Paratypi: 3 ♀, stessa provenienza.

DESCRIZIONE. Lungh. 2,2 mm. Avancorpo debolmente opaco, addome lucido. Corpo bruno con pronoto ed elitre giallo-bruni; antenne brune con i due antennomeri basali giallo-rossicci; zampe gialle. La reticolazione del capo e del pronoto è netta, quella delle elitre è quasi vigorosa e quella dell'addome è distinta. La punteggiatura del capo e delle elitre è estremamente superficiale, quella del pronoto è indistinta; edeago figg. 25-26, spermateca fig. 27, sesto urotergo libero del maschio fig. 29.

COMPARAZIONI. La nuova specie ha habitus simile a quello di *H. cooteri* Pace, 1998a, della Cina, ma gli antennomeri 4 a 10 sono nettamente trasversi e non più lunghi che larghi come in *cooteri*. La spermateca della nuova specie ha bulbo prossimale non così nettamente dilatato come quello di *cooteri*.

**Atheta (Acrotone) iperanomala** sp. n.

Figg. 30-32

Holotypus ♀, Hong Kong, Cheung Sheung, yellow pan, 27.IV.1997, G.T. Reels leg. (MHNG).

DESCRIZIONE. Lungh. 2,1 mm. Corpo lucido e giallo-bruno (immaturato); antenne brune con i due antennomeri basali e la base del terzo di un giallo sporco; zampe gialle. La reticolazione della superficie del capo è estremamente superficiale, quella delle elitre è svanita e quella del pronoto e dell'addome è assente. La punteggiatura del capo è superficiale. I tuberoletti che coprono la superficie del pronoto sono fini e poco

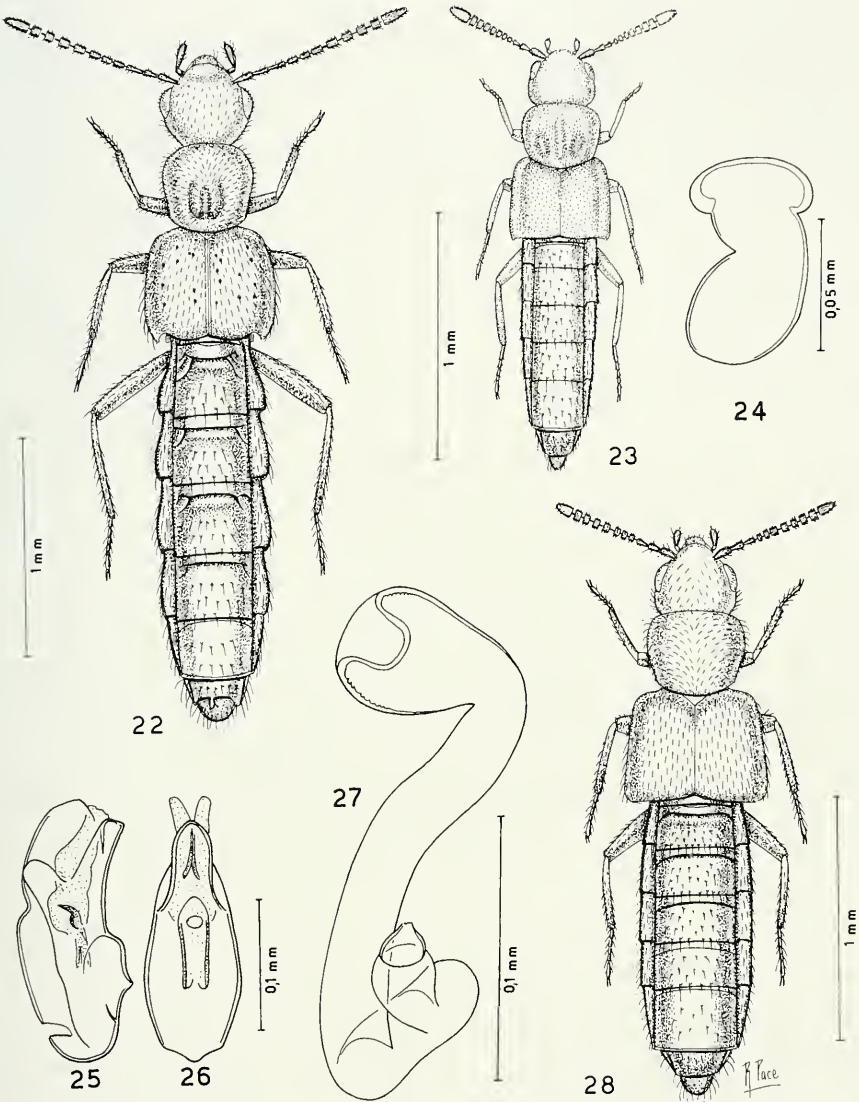

FIGG. 22-28

Habitus, spermateca ed eedeago in visione laterale e ventrale. 22: *Linoglossa hongkongensis* sp. n.; 23-24: *Demerinda rougemonti* sp. n.; 25-28: *Hydrosmecta subalgarum* sp. n.

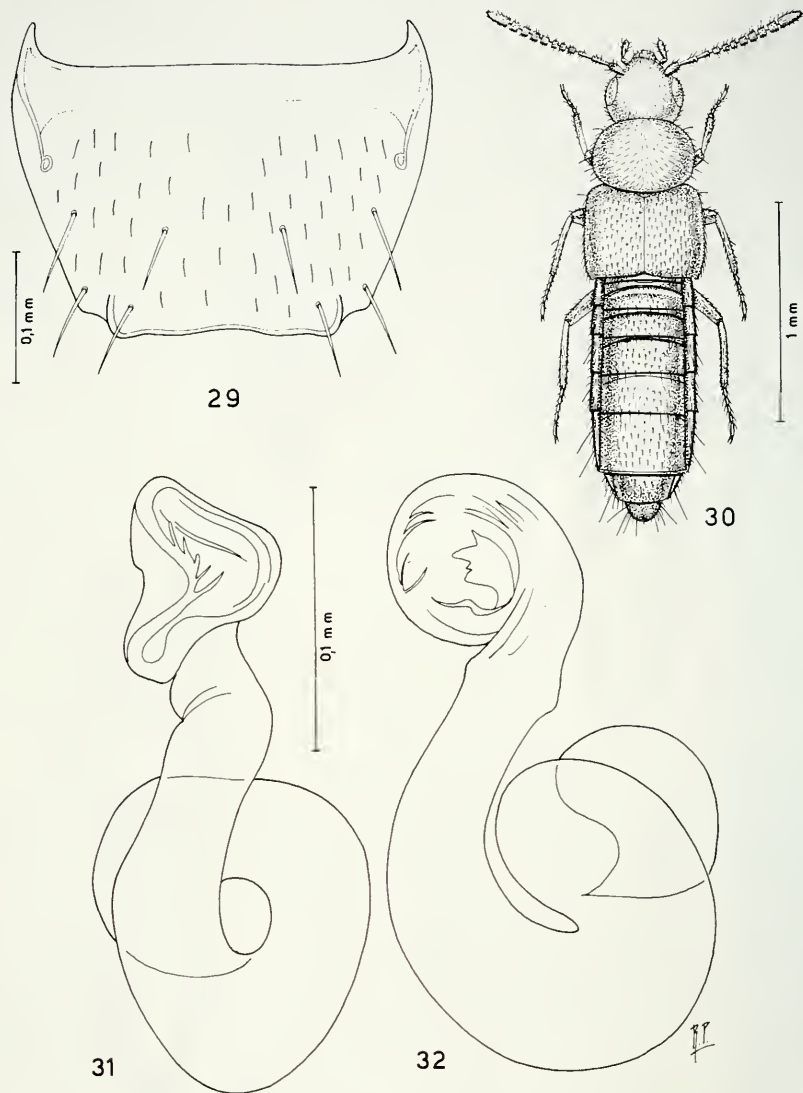

FIGG. 29-32

Sesto urotergo libero del maschio, habitus e spermateca da due differenti punti di vista. 29: *Hydrosmeeta subalgarum* sp. n.: 30-32: *Atheta (Acrotona) iperanomala* sp. n.

salienti, quelli delle elitre sono distinti e quelli dell'addome sono salienti; spermateca figg. 31-32.

COMPARAZIONI. L'habitus della nuova specie è pressoché identico a quello di *A. suspiciosa* (Motschulsky, 1859) dell'India, Sri Lanka, Singapore, Cina meridionale e Filippine, cioè l'addome è appena ristretto all'indietro e la reticolazione del capo è estremamente superficiale. Ma la spermateca è nettamente differente nelle due specie. La parte prossimale della spermateca di *suspiciosa* descrive una sola spira, mentre nella nuova specie ne descrive due e il bulbo distale è senza introflessione apicale in *suspiciosa*, mentre è molto sviluppato in profondità nella nuova specie.

***Atheta (Acrotona) shekkongensis* sp. n.**

Figg. 33-36

Holotypus ♂, Hong Kong, Shek Kong, at light, 24.VIII.1991, G. Ades leg. (MHNG).

Paratypos: 1 ♀, stessa provenienza.

DESCRIZIONE. Lungh. 2,2 mm. Corpo lucido e bruno-rossiccio con quarto urite libero bruno; antenne brune con antennumero basale bruno-rossiccio; zampe gialle. La superficie del capo è coperta di reticolazione estremamente superficiale, il resto della superficie del corpo è senza reticolazione. La superficie del capo e del pronoto è coperta di tubercoletti fini e distinti; le elitre presentano tubercoletti superficiali; edeago figg. 34-35, spermateca fig. 36.

COMPARAZIONI. Un numero di caratteri dell'edeago e della spermateca permette di avvicinare tassonomicamente la nuova specie ad *A. vicaria* (Kraatz, 1859), diffusa dallo Sri Lanka all'India e alle Filippine. Le differenze sono le seguenti: i penultimi antennumeri di *vicaria* sono nettamente trasversi, mentre nella nuova specie sono poco trasversi; gli occhi in *vicaria* sono lunghi quanto le tempie, mentre nella nuova specie gli occhi sono molto più lunghi delle tempie; l'addome di *vicaria* è appena ristretto all'indietro, mentre nella nuova specie è fortemente ristretto; il dente preapicale dorsale dell'edeago di *vicaria* è vicinissimo all'apice, mentre nella nuova specie è piuttosto lontano; i due pezzi falciformi interni dell'edeago di *vicaria* sono nettamente più lunghi di quelli corrispondenti nella nuova specie.

***Atheta (Acrotona) tricholutea* sp. n.**

Figg. 37-38

Holotypus ♀, Hong Kong N.T., Kadoorie Agricultural Research Centre, flight interception trap, X-XII.1996, G. de Rougemont leg. (MHNG).

DESCRIZIONE. Lungh. 2,1 mm. Corpo lucido e giallo-rossiccio con capo rossicci, con elitre brune orlate di giallo alla sutura e al margine posteriore e con quarto urite libero bruno; antenne brune con i due antennumeri basali e la base del terzo gialli; zampe gialle. Solo le elitre mostrano una reticolazione distinta e fine: sul resto della superficie del corpo non vi è traccia di reticolazione. La punteggiatura del capo e del pronoto è fitta e superficiale. I tubercoletti che coprono la superficie delle elitre sono fitti e superficiali, quelli degli uroterghi sono salienti; spermateca fig. 38.

COMPARAZIONI. Il colore prevalentemente giallo-rossiccio del corpo e il tipo di spermateca, permettono di avvicinare tassonomicamente la nuova specie ad *A. mannuliventris* Pace, 1998b, pure di Hong Kong. Il corpo della nuova specie però è più

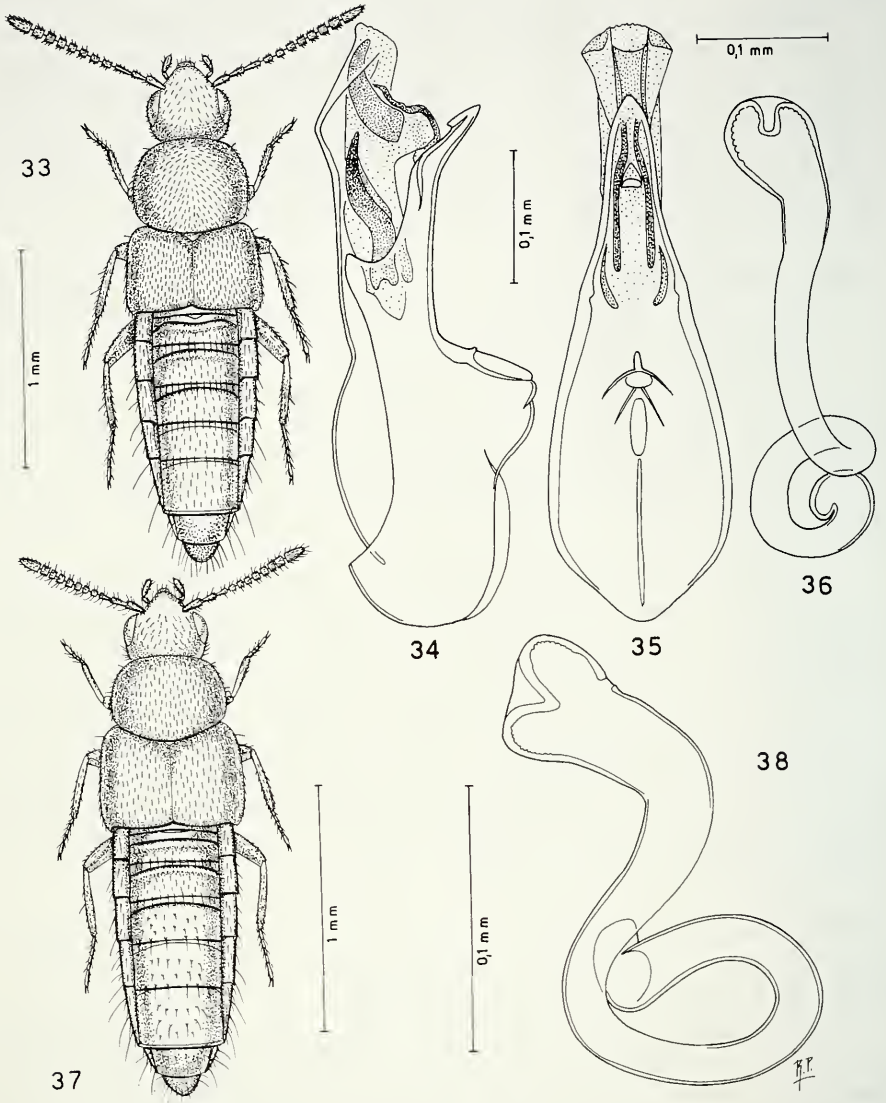

FIGG. 33-38

Habitus, edeago in visione laterale e ventrale e spermatheca. 33-36: *Atheta (Acrotona) shekkongensis* sp. n.; 37-38: *Atheta (Acrotona) tricholutea* sp. n.

robusto di quello di *mimannuliventris*, gli occhi sono più lunghi delle tempie, mentre in *mimannuliventris* sono più corti delle tempie. La spermateca della nuova specie ha parte prossimale più prolungata e più sottile della parte corrispondente della spermateca di *minannuliventris* e l'inflessione apicale del bulbo distale è nettamente meno profonda nella nuova specie.

**Atheta (Coprothassa) roridanotha** sp. n.

Figg. 39-46

Holotypus ♂, Hong Kong, Kadoorie Agricultural Research Centre, flight interception trap, X-XII.1996, De Rougemont leg. (MHNG).

Paratypus: 1 ♀, Hong Kong, Ma On Shan, at light, 16.X.1996, G.T. Reels.

DESCRIZIONE. Lungh. 2,9 mm. Corpo lucido e bruno con elitre giallo-brune; antenne brune con i due antennomeri basali giallo-bruni; zampe gialle. Sul capo e sul pronoto la reticolazione è assente. La reticolazione delle elitre è estremamente superficiale e quella dell'addome è distinta. L'avancorpo è coperto di tubercoletti salienti, fitti e regolari; edeago figg. 40-41, spermateca fig. 42.

COMPARAZIONI. La nuova specie è chiaramente distinta sia per i caratteri dell'edeago, che della spermateca, da *A. iucunda* Pace, 1998b della Cina. L'edeago della nuova specie è appena ricurvo al lato ventrale, mentre è profondamente arcuato in *iucunda* e il bulbo distale della spermateca è meno dilatato nella nuova specie che in *iucunda*.

**Atheta (Microdota) pseudovagans** sp. n.

Figg. 47-50

Holotypus ♂, Hong Kong, C.U.H.K., flight interception trap, III-IV.1997, G. de Rougemont leg. (MHNG).

DESCRIZIONE. Lungh. 1,8 mm. Avancorpo debolmente opaco, addome lucido. Corpo bruno con elitre giallo-brune e addome nero-bruno; antenne brune con i due antennomeri basali bruno-rossicci; zampe gialle. La reticolazione del capo e del pronoto è netta, quella delle elitre è indistinta e quella dell'addome è superficiale. L'intero corpo è coperto di tubercoletti distinti, tranne sul disco del capo dove mancano; edeago figg. 48-49, sesto urotergo libero del maschio fig. 50.

COMPARAZIONI. La nuova specie ha habitus simile a quello di *A. vagans* Bernhauer, 1907, diffusa dallo Sri Lanka a Taiwan, Cina e Giappone. Solo gli occhi sono più sviluppati e gli antennomeri 8 a 10 meno fortemente trasversi. Il margine posteriore del sesto urotergo libero del maschio della nuova specie ha forma come da fig. 50, mentre in *vagans* è plurinciso a metà. Inoltre l'apice dell'edeago della nuova specie è stretto, mentre è molto largo in *vagans*.

**Atheta (Microdota) persimplex** sp. n.

Figg. 51-54

Holotypus ♂, Hong Kong, C.U.H.K., flight interception trap, III-IV.1997, G. de Rougemont leg. (MHNG).

DESCRIZIONE. Lungh. 1,4 mm. Corpo lucido e bruno (immaturo); antenne nero-brune; zampe di un giallo sporco. La reticolazione del capo è molto svanita, quella del

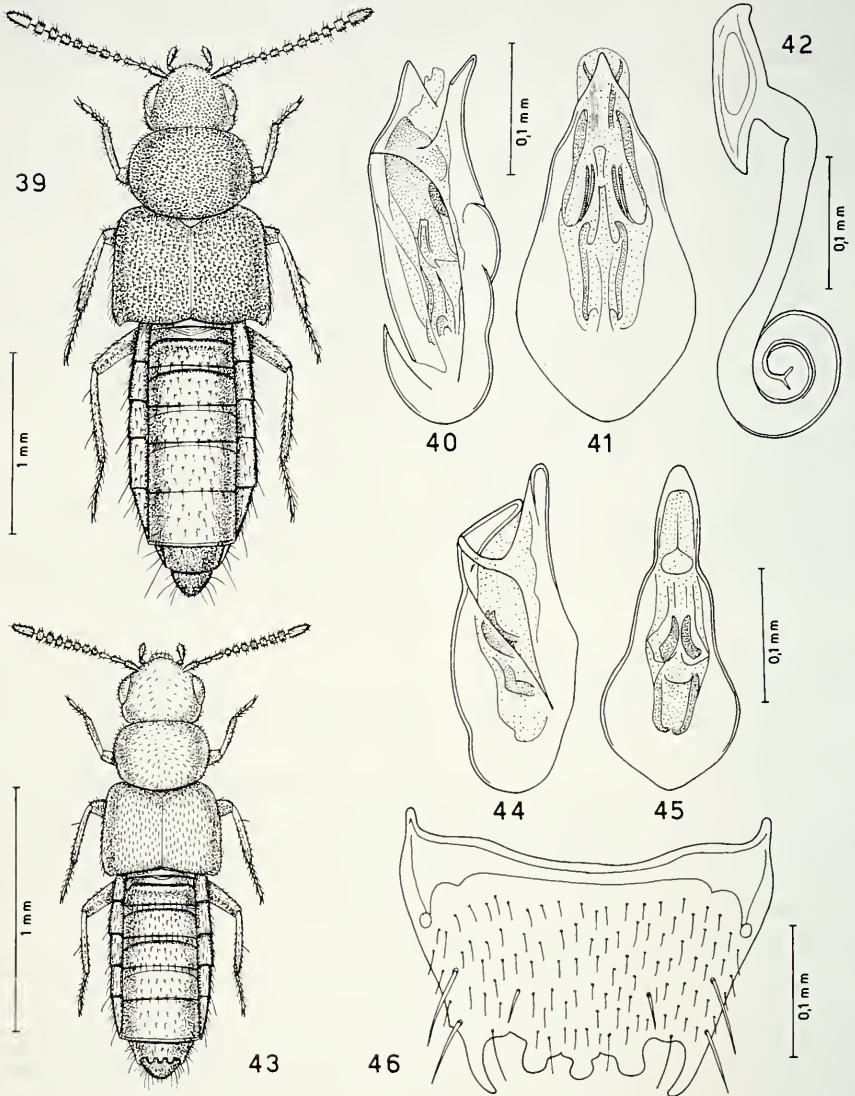

FIGG. 39-46

Habitus, eedeago in visione laterale e ventrale, spermateca e sesto urotergo libero del maschio. 39-42: *Atheta (Coprothassa) roridanotha* sp. n.; 43-46: *Atheta (Microdota) ocellaris* Cameron, es. di Hong Kong.



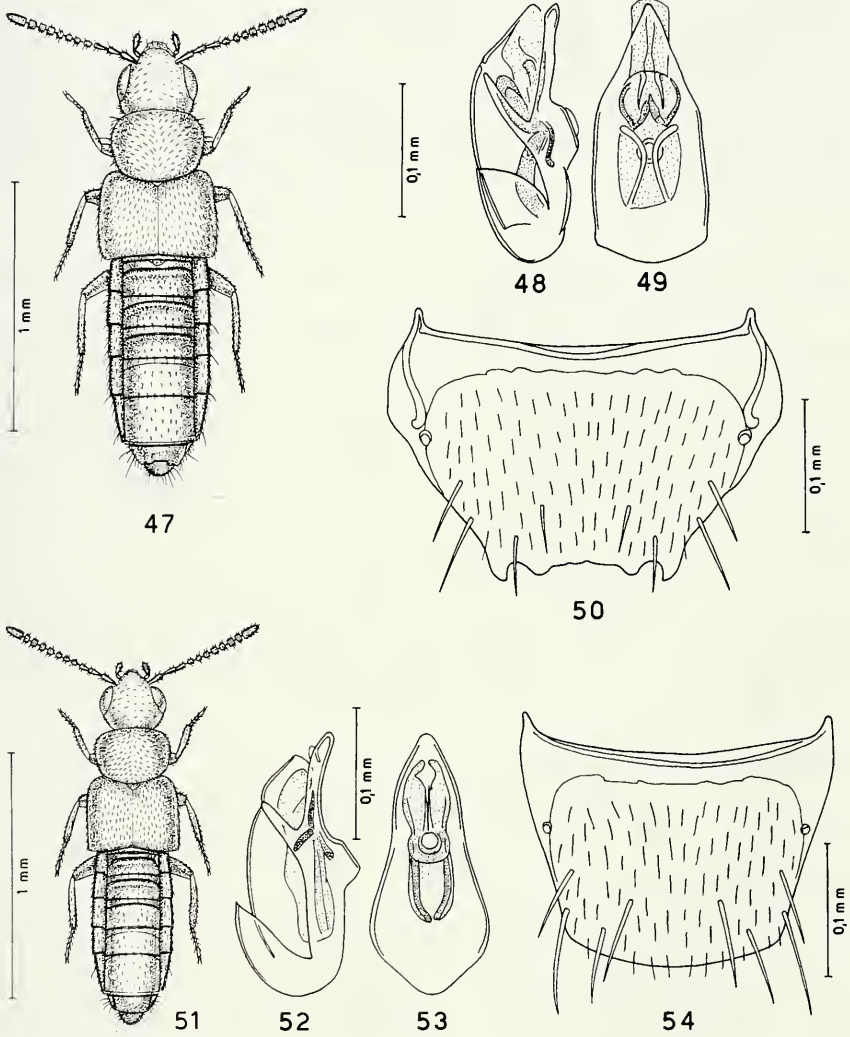

FIGG. 47-54

Habitus, edeago in visione laterale e ventrale e sesto urotergo libero del maschio. 47-50: *Atheta (Microdota) pseudovagans* sp. n.; 51-54: *Atheta (Microdota) persimplex* sp. n.

pronoto è assente, quella delle elitre è superficiale e quella dell'addome è distinta. I tubercoletti che coprono la superficie del capo sono superficiali, quelli del pronoto sono salienti, quelli delle elitre distinti e quelli dell'addome sono fini; edeago figg. 52-53, sesto urotergo libero del maschio fig. 54.

COMPARAZIONI. La nuova specie ha edeago simile a quello di *A. pauxilla* Cameron, 1944, dell'India, ma l'apice di quello della nuova specie è nettamente più stretto di quello di *pauxilla*. Gli occhi della nuova specie sono più lunghi delle tempie, mentre quelli di *pauxilla* sono molto più corti delle tempie e il quarto antennumero è lungo quanto largo nella nuova specie, mentre è nettamente trasverso in *pauxilla*.

**Atheta (Poromicrodota) hoihaensis** sp. n.

Figg. 55-56

Holotypus ♀, Hong Kong, Hoi Ha, flight interception trap, 14.II.1996, G.T. Reels leg. (MHNG).

DESCRIZIONE. Lungh. 2,4 mm. Corpo lucido e nero pece, con elitre e base dell'addome brune; antenne nere con i due antennumeri basali nero-bruni; zampe gialle con femori giallo-bruni. La reticolazione della superficie dell'avancorpo è molto superficiale, quella degli uroterghi è distinta e composta di maglie molto trasverse. I tubercoletti che coprono la superficie del capo e delle elitre sono fini e poco salienti, quelli del pronoto sono distinti; spermateca fig. 56.

COMPARAZIONI. La nuova specie ha spermateca simile a quella di *A. sororcula* Cameron, 1939, dell'India e Nepal, ma la nuova specie ha occhi più lunghi delle tempie, mentre *sororcula* li ha molto più corti e l'introflessione apicale del bulbo distale della spermateca della nuova specie è larghissima, mentre è stretta in *sororcula*.

**Atheta (Sipalatheta) algarum** sp. n.

Figg. 59-62

Holotypus ♂. Hong Kong, Ting Kok, seaweed, 8.III.1997, G. de Rougemont leg. (MHNG).

Paratypi: 2 ♂ e 2 ♀, stessa provenienza; 1 ♀. Hong Kong, Sha Lanq, seaweed on beach, 8.III.1997, G. de Rougemont leg.

Descrizione. Lungh. 2,3 mm. Corpo lucido e bruno; antenne brune con i due antennumeri basali rossicci; zampe giallo-rossicce. La reticolazione del capo e del pronoto è netta, quella delle elitre è distinta e quella dell'addome è superficiale. La punteggiatura del capo e del pronoto è estremamente superficiale. Tubercoletti molto svaniti coprono la superficie delle elitre; spermateca fig. 59, edeago figg. 60-61.

COMPARAZIONI. La struttura dell'edeago della nuova specie, priva di apofisi laterali, richiama la forma dell'edeago di *A. ciu* Pace, 1993, della Cina. Tuttavia l'edeago della nuova specie presenta un dente preapicale dorsale, assente in *ciu* e il bulbo basale dello stesso organo è più sviluppato in *algarum* sp. n. che in *ciu*. Inoltre il bulbo distale della spermateca della nuova specie è poco sviluppato, senza distinta inflessione apicale, mentre in *ciu* il bulbo distale è molto sviluppato, con profonda inflessione apicale. In più gli occhi della nuova specie sono più corti delle tempie, mentre in *ciu* sono lunghi quanto le tempie.

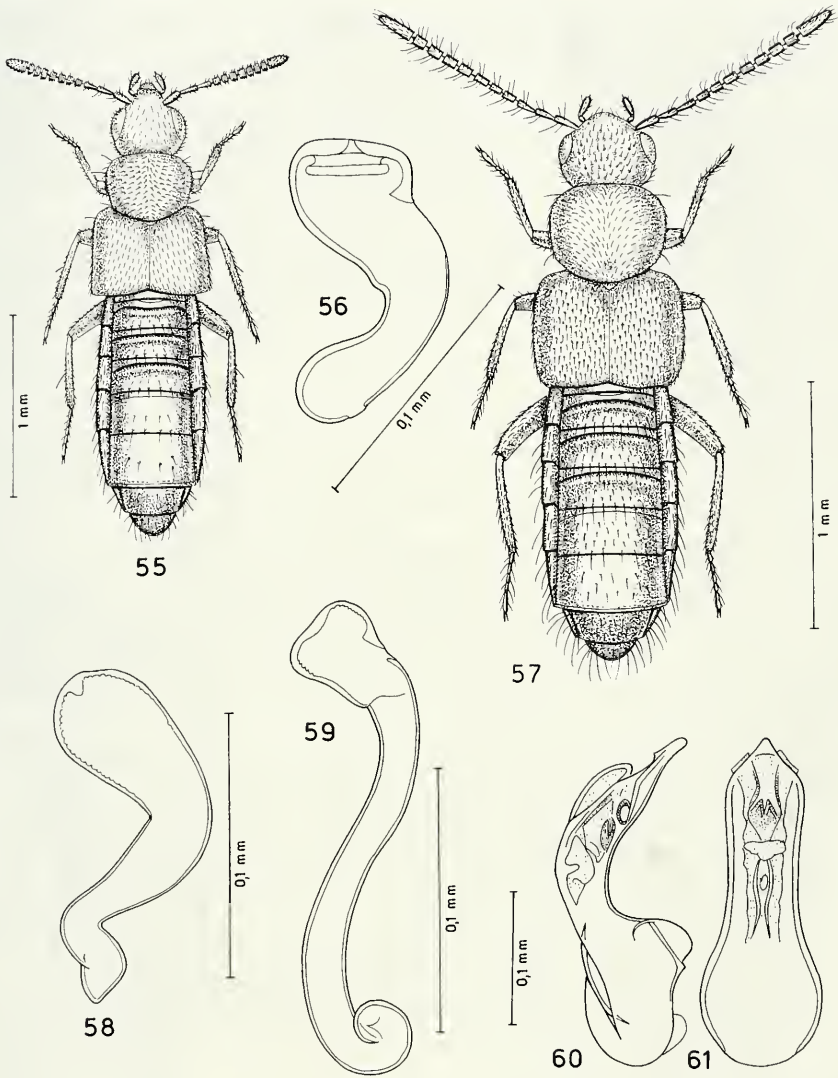

FIGG. 55-61

Habitus, spermateca ed edeago in visione laterale e ventrale. 55-56: *Atheta (Poromicrodota) hoihaensis* sp. n.; 57-58: *Gnypta lucidula* Pace di Hong Kong; 59-61: *Atheta (Sipalatheta) algarum* sp. n.

**Tomoglossa fuliginosa** sp. n.

Figg. 63-64

Holotypus ♀, Hong Kong N.T., sifted litter, 1.II.1997, G. de Rougemont leg. (MHNG).  
Paratypus: 1 es. (privo di pigidio), stessa provenienza.

DESCRIZIONE. Lungh. 2,3 mm. Corpo lucido e bruno con capo nero-bruno ed elitre giallo-brune; antenne brune con i due antennomeri basali bruno-rossicci; zampe gialle. Tutto il corpo è coperto di reticolazione distinta, sull'addome è a maglie molto trasverse. Tuberoletti salienti sono diffusi fittamente su tutta la superficie del corpo; spermateca fig. 63.

COMPARAZIONI. La nuova specie è ben distinta da *T. subcorticalis* (Cameron, 1939) dell'India, per il pronoto nettamente trasverso (pronoto appena trasverso in *subcorticalis*) e per l'introflessione apicale del bulbo distale assai largo nella nuova specie e strettissimo in *subcorticalis*.

PYGOSTENINI Fauvel, 1899

**Odontoxenus reelsi** sp. n.

Figg. 65-66

Holotypus ♀, Hong Kong, Kau Tam Tso, yellow pan. 18.V.1996, S.J. Reels leg. (MHNG).

DESCRIZIONE. Lungh. 2,7 mm. Corpo lucidissimo e giallo-rossiccio con capo bruno e con margine posteriore del pronoto, metà posteriore delle elitre e pigidio giallo-rossicci chiari; antenne bruno-rossicce con antennomero basale giallo-rossiccio; zampe rossicce. Il corpo è senza reticolazione. La punteggiatura dell'avancorpo è rada e superficiale. Solo gli uroterghi liberi IV, V e VI sono coperti di pubescenza; spermateca fig. 66.

COMPARAZIONI. A Hong Kong è presente un'altra specie: *O. rougemonti* Pace, 1998c. La nuova specie si distingue da essa per i caratteri dati nella seguente chiave:

- Antenne lunghe: volte all'indietro raggiungono il margine posteriore delle elitre; pronoto fortemente trasverso; capo con doppia punteggiatura; uroterghi liberi IV e V coperti di setoline allineate trasversalmente; femmina sconosciuta. Lungh. 1,9 mm. . . . . *rougemonti* Pace
- Antenne corte: volte all'indietro raggiungono la base delle elitre; pronoto debolmente trasverso; capo con punteggiatura rada e superficiale; uroterghi liberi IV et V diffusamente coperti di pubescenza; maschio sconosciuto. Lungh. 2,7 mm. . . . . *reelsi* sp. n.

TERMITOPAEDIINI Seevers, 1957

**Dioxeuta rougemonti** sp. n.

Figg. 67-69

Holotypus ♂. Hong Kong, Pak Ngao Shek, leaf litter, 26.X.1996, J. Fellowes leg. (MHNG).

Paratypi: 2 ♂. Hong Kong, Lin Au, flight interception trap, 26.X.1997, G.T. Reels leg.

DESCRIZIONE. Lungh. 2,0 mm. Corpo lucido e giallo con elitre giallo-brune e addome oscurato di bruno agli uriti liberi III e IV; antenne e zampe gialle (immaturato). La reticolazione sulla superficie del capo e del pronoto è assente, quella delle elitre è molto svanita e quella dell'addome è superficiale. Non è presente una visibile

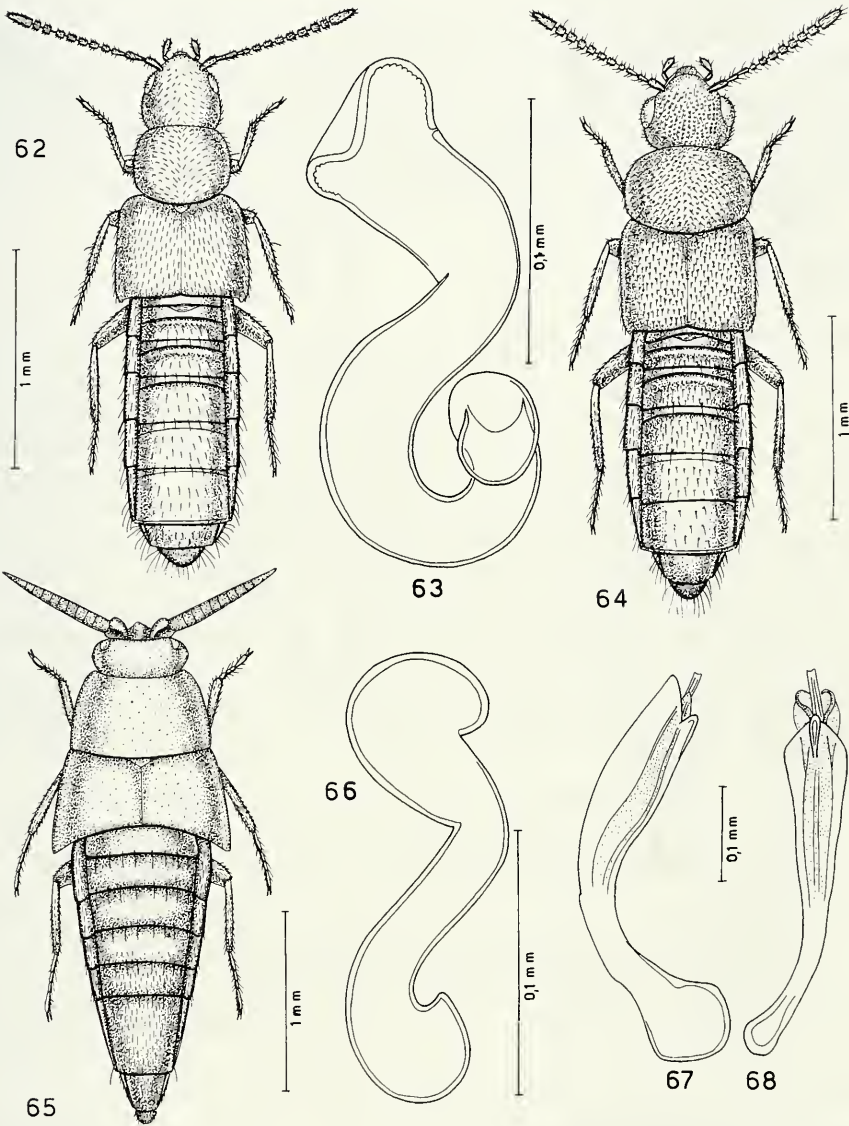

FIGG. 62-68

Habitus, spermateca ed edeago in visione laterale e ventrale. 62: *Atheta (Sipalatheta) algarum* sp. n.; 63-64: *Tomoglossa fuliginosa* sp. n.; 65-66: *Odontoxenus reelsi* sp. n.; 67-68: *Dioxeuta rouge-monti* sp. n.

punteggiatura su tutto il corpo. Rade setole sono inserite sul corpo come da fig. 69; edeago figg. 67-68.

COMPARAZIONI. La nuova specie è affine a *D. flavescens* (Cameron, 1939) della Birmania. Se ne distingue per le antenne ancor più lunghe, cioè lunghe quanto quattro volte e mezzo la lunghezza del pronoto (e non solo quattro volte come in *flavescens*). Inoltre il pronoto della nuova specie è quasi lungo quanto largo, mentre in *flavescens* è nettamente trasverso (rapporto larghezza/lunghezza pari a 0,08 nella nuova specie e pari a 0,78 in *flavescens*). Di *flavescens* non è noto l'edeago.

MYRMEDONIINI Thomson, 1867

**Zyras** (*Sinozyras* subgen. n.) **pygmaeus** sp. n.

Figg. 70-73

Holotypus ♀, Hong Kong, Lung Kwu Chao, at light, 18.X.1997, S.J. Reels leg. (MHNG).

DESCRIZIONE. Lungh. 2,8 mm. Corpo lucidissimo e giallo-rossiccio con capo e uriti liberi IV, V e VI bruno-rossicci; antenne bruno-rossicce con i due antenomeri basali e la base del terzo gialli; zampe gialle. L'intera superficie corporea è senza reticolazione. La punteggiatura del capo è molto superficiale e assente sulla fascia longitudinale mediana, quella del pronoto è distinta e assente sulla fascia mediana. Le elitre sono coperte di tubercoletti fini e superficiali. L'addome presenta tubercoletti distinti. Il pronoto ha una profonda fossetta mediana posteriore; spermateca fig. 73.

COMPARAZIONI. La taglia corporea ridotta, gli occhi molto più corti delle tempie e gli antenomeri IV a X notevolmente trasversi, sono caratteri distintivi che permettono di attribuire la nuova specie a un sottogenere nuovo. *Sinozyras*, tassonomicamente vicino a *Zyras* (*Zyras*) da cui si distingue anche per i caratteri dati nella seguente chiave:

- Ligula divisa in due larghi lembi, con setole apicali; mento poco trasverso; mesocoxe largamente separate tra loro dato che il processo metasternale è larghissimo, tronco all'estremità e insinuato profondamente tra le mesocoxe. . . . . Subgen. *Zyras* (*Zyras*)
- Ligula divisa in due lembi stretti, senza setole apicali; mento estremamente trasverso; mesocoxe appena separate tra loro dato che il processo metasternale è appuntito e insinuato per breve tratto tra le mesocoxe . . . . . Subgen. *Zyras* (*Sinozyras* n.)

Typus subgeneris: *Zyras* (*Sinozyras*) *pygmaeus* sp. n.

**Zyras** (*Zyras*) **hongkongensis** sp. n.

Figg. 74-77

Holotypus ♂, Hong Kong, Tai Long, at light, 11.III.1997, G.T. Reels leg. (MHNG).

Paratypi: 2 ♀, stessa provenienza.

DESCRIZIONE. Lungh. 5,0 mm. Corpo lucidissimo e nero con pronoto e base dell'addome giallo-rossicci; antenne giallo-rossicce con i tre antenomeri basali bruni e l'undicesimo giallo; femori gialli con estremità distale bruna, tibie anteriori giallo-brune, medie e posteriori gialle; tarsi gialli. La superficie del corpo è senza reticola-

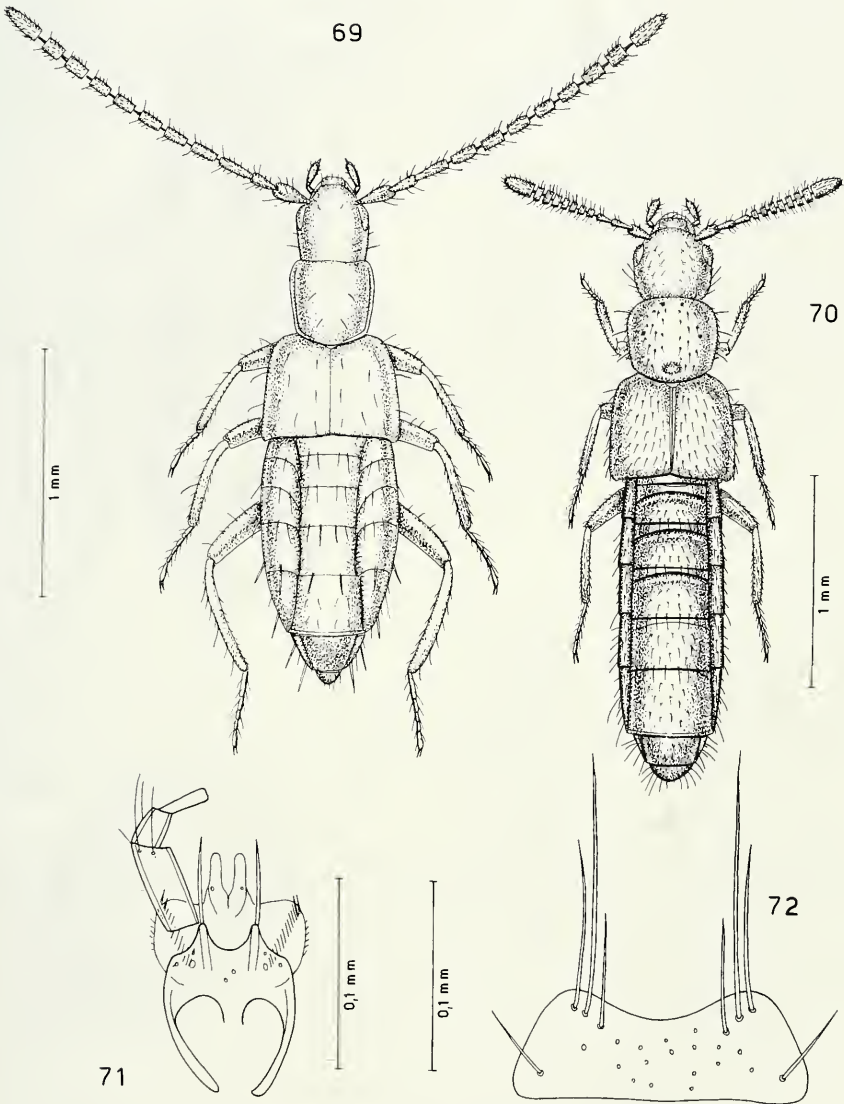

FIGG. 69-72

Habitus, labio con palpo labiale e mento. 69: *Dioxeuta rougemonti* sp. n.; 70-72: *Zyras* (*Sinozyras* subgen. n.) *pygmaeus* sp. n.

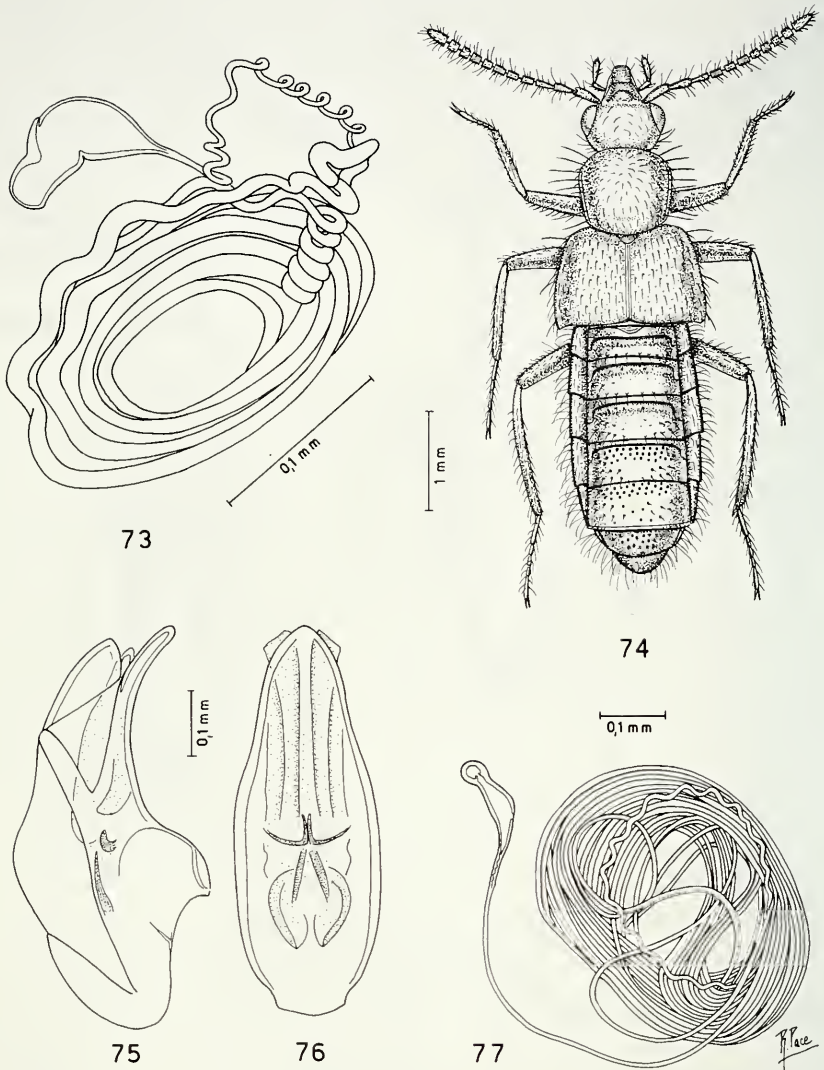

FIGG. 73-77

Spermateca, habitus ed edeagò in visione laterale e ventrale. 73: *Zyras* (*Sinozyras* subgen. n.) *pygmaeus* sp. n.; 74-77: *Zyras* (*Zyras*) *hongkongensis* sp. n.



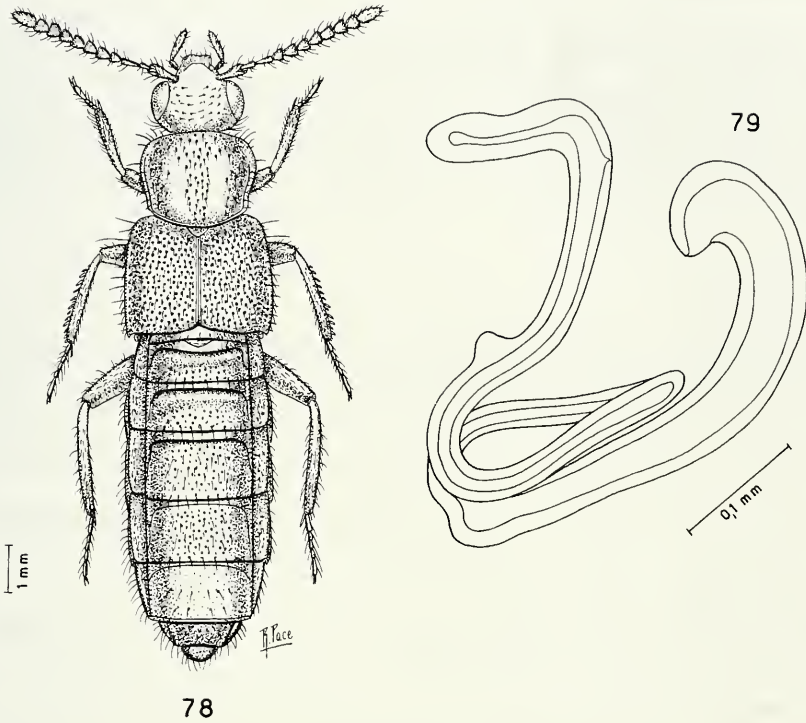

FIGG. 78-79

*Zyras (Glossacantha) yangi* Bernhauer, es. di Hong Kong. Habitus della femmina: 78; spermatoteca: 79.

zione. La punteggiatura del capo e del pronoto è finissima, assente sulla linea mediana del capo. Tuberoletti fini coprono la superficie delle elitre. La punteggiatura dell'addome è netta e distribuita come da fig. 74; edeago figg. 75-76, spermatoteca fig. 77.

COMPARAZIONI. Poiché la nuova specie presenta capo e pronoto non fortemente punteggiati, è comparabile solo con *Z. chinkiangensis* Bernhauer, 1939, della Cina, che ha il medesimo carattere. Se ne distingue per i caratteri dati nella seguente chiave:

- Pronoto molto trasverso, con fossetta mediana posteriore profonda e circolare; decimo antennumero appena trasverso; edeago di un terzo più lungo e bruscamente arcuato al lato ventrale, con apice appuntito, in visione ventrale. Lungh. 7,5 mm. Cina nord-occidentale.  
 ..... *chinkiangensis* Bernhauer
- Pronoto appena trasverso, con impressione mediana posteriore trasversa; edeago di un terzo meno lungo, arcuato al lato ventrale in modo debole, con apice a larga ogiva, in visione ventrale. Lungh. 5,0 mm. Hong Kong.  
 ..... *hongkongensis* sp. n.

## RINGRAZIAMENTI

Ringrazio vivamente il collega Guillaume de Rougemont, noto studioso di Staphylinidae di Londra, per avermi affidato in studio il materiale oggetto del presente lavoro, frutto di sue ricerche e di G.T. Reels, G. Ades e J. Fellowes che pure sentitamente ringrazio insieme ai conservatori del Natural History Museum di Londra e Field Museum of Natural History di Chicago per il prestito di tipi e di materiale di confronto.

## BIBLIOGRAFIA

- BERNHAEUER, M. 1907. Zur Staphyliniden-Fauna von Japan. *Verhandlungen der zoologisch-botanischen Gesellschaft in Wien* 57: 371-414.
- BERNHAEUER, M. 1938. Zur Staphyliniden-Fauna von China und Japan (XI. Beitrag). *Entomologisches Nachrichtenblatt Troppau* 12: 145-158.
- CAMERON, M. 1919. New species of Staphylinidae from Singapore. Part II. *Transactions of the Entomological Society of London* 1918: 231-246.
- CAMERON, M. 1927. Descriptions of two new genera of termitophilous Staphylinidae from India. *Entomologist's Monthly Magazine* 63: 222-224.
- CAMERON, M. 1939. The Fauna of British India, including Ceylon and Burma. Coleoptera. Staphylinidae 4: 410 pp., London.
- CAMERON, M. 1944. Descriptions of new Staphylinidae (Coleoptera). *Proceedings of the Royal Entomological Society of London* 13: 49-52.
- CASEY, T.L. 1910. New species of the Staphylinid tribe Myrmedoniini. In: *Memoirs on the Coleoptera* I: 183 pp., Lancaster.
- FAUVEL, A. 1899. Sur une tribu nouvelle de Staphylinides (Pygostenini). In: RAFFRAY, A. & FAUVEL, A.: *Genres et espèces de Staphylinides nouveaux d'Afrique*. *Revue d'Entomologie* 18: 1-44.
- GANGLBAUER, L. 1895. Die Käfer von Mitteleuropa. Vol. 2. Familienreihe Staphylinidae. I. Teil. Staphylinidae, Pselaphidae: 881 pp., Vienna.
- KRAATZ, G. 1856. Naturgeschichte der Insekten Deutschlands. Abteilung I. Coleoptera. Vol. 2, Staphylinii: 376 pp., Berlin.
- KRAATZ, G. 1859. Die Staphyliniden-Fauna von Ostindien, insbesondere der Insel Ceylan. *Archiv für Naturgeschichte* 25: 1-196.
- MOTSCHULSKY, V. DE. 1858. Énumération des nouvelles espèces de Coléoptères rapportées de ses voyages. *Bulletin de la Société impériale des Naturalistes de Moscou* 3: 204-246.
- MOTSCHULSKY, V. DE. 1859. Insectes des Indes orientales et des contrées analogues. *Études Entomologiques* 8: 25-118.
- MULSANT, E. & REY, C. 1871. Histoire Naturelle des Coléoptères de France. Brévipennes. Aléochariens: 321 pp., Paris.
- PACE, R. 1986. Aleocharinae dell'Asia Sudorientale raccolte da G. de Rougemont. *Bollettino del Museo civico di Storia naturale di Verona* 13: 139-237.
- PACE, R. 1987. Staphylinidae dell'Himalaya Nepalese. Aleocharinae raccolte dal Prof. Dr. J. Martens (Insecta: Coleoptera). *Courier Forschungsinstitut Senckenberg* 93: 386-441.
- PACE, R. 1988 (1997). Aleocharinae dello Sri Lanka raccolte da Marc Tronquet. *Bollettino del Museo civico di Storia naturale di Verona* 14: 315-338.
- PACE, R. 1992. Aleocharinae del Vietnam (Coleoptera. Staphylinidae). *Nouvelle Revue d'Entomologie* (N.S.) 9: 119-129.

- PACE, R. 1993. Aleocharinae della Cina. *Bollettino del Museo civico di Storia naturale di Verona* 17: 127-180.
- PACE, R. 1998. Aleocharinae della Cina: Parte I (Coleoptera, Staphylinidae). *Revue suisse de Zoologie* 105: 139-220.
- PACE, R. 1998a. Aleocharinae della Cina: Parte II (Coleoptera, Staphylinidae). *Revue suisse de Zoologie* 105: 395-463.
- PACE, R. 1998b. Aleocharinae della Cina: Parte III (Coleoptera, Staphylinidae). *Revue suisse de Zoologie* 105: 665-732.
- PACE, R. 1998c. Aleocharinae della Cina: Parte IV (Coleoptera, Staphylinidae). *Revue suisse de Zoologie* 105: 000-000.
- SEEVERS, C.H. 1957. A Monograph on the Termitophilous Staphylinidae (Coleoptera). *Fieldiana: Zoology* 40: 344 pp.
- SEEVERS, C.H. 1965. The systematics, evolution and zoogeography of Staphylinid Beetles associated with Army Ants (Coleoptera, Staphylinidae). *Fieldiana: Zoology* 47: 137-351.
- SHARP, D. 1883. Fam. Staphylinidae. *In: Biologia Centrali-Americana. Insecta. Coleoptera, Vol. I: 145-312.*



## A review of the Scaphidiinae (Coleoptera: Staphylinidae) of the People's Republic of China, I

Ivan LÖBL

Muséum d'histoire naturelle, Case postale 6434, CH-1211 Geneva 6, Switzerland.

**A review of the Scaphidiinae (Coleoptera: Staphylinidae) of the People's Republic of China, I.** - The present paper is the first part of a review of the Scaphidiinae of People's Republic of China. It treats 78 species in 12 genera. New species are: *Cyparium sichuanum* sp. n., *Ascaphium irregulare* sp. n., *A. alticola* sp. n., *Episcaphium catenatum* sp. n., *E. strenuum* sp. n., *E. haematoides* sp. n., *Scaphidium inexpectatum* sp. n., *S. jizuense* sp.n., *S. kubani* sp. n., *S. becvari* sp. n., *S. kurbatovi* sp. n., *S. lunare* sp. n., *S. schuelkei* sp. n., *S. stigmatinotum* sp. n., *S. sichuanum* sp. n., *Baeocera xichangana* sp. n., *B. huashana* sp. n., *B. cooteri* sp. n., *B. kubani* sp. n., *B. yunnanensis* sp. n., *Scaphobaocera simplex* sp. n., *S. molesta* sp. n., *S. pseudovalida* sp.n., and *Toxidium villosum* sp. n. *Scaphidium tsushinense* Shirôzu & Morimoto, 1963 is placed in synonymy of *Scaphidium amurense* Solsky, 1871. Lectotypes are designated for *Cyparium yunnanum* (Achard); *Ascaphium minus* Pic, *A. sinense* Pic, *Scaphidium delatouchei* Achard, *S. fukiense* Pic, *S. klapperichi* Pic, *S. verrucatum* (Pic), *S. yunnanum* Fairmaire, *Pseudobiroonium sinicum* Pic. Keys to species are provided.

**Key-words:** Coleoptera - Staphylinidae - Scaphidiinae - taxonomy - China.

### INTRODUCTION

The scaphidiines with almost 1400 species currently recognized is one of the more speciose groups of mycophagous beetles. While large collections from the Indian subcontinent, including Himalaya, Thailand and Japan were studied previously by me and the faunas of these areas appear reasonably well documented, very little is known about the scaphidiines of China. The gaps in the knowledge obscure recognition of eventual centres of endemism and understanding distributional patterns of the taxa recorded from neighbouring countries.

Thus, the collections of scaphidiines of the People's Republic of China which became available since the last decade provide significant new information. Based on this material, a review of the scaphidiines of China is given. The present paper deals with all genera but *Scaphisoma* Leach which will be treated in a separate study. In respect to the size and habitat diversity of China, the scaphidiines appear under-represented compared to other parts of Asia (e.g. LÖBL 1979, 1990b, 1992). Obviously, the available information is still anecdotal, and strongly depends on the

accessibility of the sites and methods used by the collectors. In particular, the field work in high altitudes yield significant material from several mountains of Yunnan and Sichuan, while the material from low altitude sites is inadequate, with the possible exception of that from Hong Kong.

Since 1886, when FAIRMAIRE described the first species from China, *Scaphidium yunnanum*, little information was published afterwards. ACHARD (1920a, 1920b, 1920c), PIC (1916, 1920, 1954), LÖBL (1965, 1972, 1984b), and LI (1992) provided isolated descriptions of 18 species, two of which were synonymized. LÖBL (1966, 1968, 1970, 1984b) and LI & CHEN (1993) recorded a few additional species, and Rougemont (1996) published a list of species of Hong Kong, based on identifications made by me. Presently, 31 identified and three additional unidentified species have been reported from the People's Republic of China (referred below to as China).

The classification of the higher taxa follows LESCHEN & LÖBL (1995) and methods follow LÖBL (1992). A key to the genera is given in the latter paper but for distinguish characters of *Episcaphium* and *Ascaphium* see also LESCHEN & LÖBL (1995). For references to previous descriptions and synonymy see the catalogue by LÖBL (1997).

Acronyms of the collections examined:

MHNG	Muséum d'histoire naturelle, Genève
MMUE	The Manchester Museum, Manchester
MNHN	Muséum National d'Histoire Naturelle, Paris
NHMB	Naturhistorisches Museum, Basel
NHRM	Naturhistoriska Riksmuseet, Stockholm
NMPC	Narodní Muzeum, Praha
PCAP	Private collection A. Pütz, Eisenhüttenstadt
PCMS	Private collection M. Schülke, Berlin
SMNS	Staatliches Museum für Naturkunde, Stuttgart

## SYSTEMATICS

### *Cyparium* Erichson

This genus comprises 47 valid species occurring in all major biogeographical areas, except New Guinea and Australia. A single species, *Cyparium yunnanum* (Achard), was known previously from China. Five additional species are mentioned in this study, one of which is new.

#### KEY TO THE SPECIES OF *CYPARIUM* OF CHINA

- 1 Elytra dark, with yellow humeral spot and yellow apical fascia  
..... *C. montanum* Achard
- Elytra unicoloured ..... 2
- 2 Pronotum and elytra microsculptured and iridescent. Large species 4.5-  
6.0 mm long ..... *C. mikado* Achard
- Pronotum and elytra without microsculpture and not iridescent ..... 3

- 3 Prohypomera with microsculpture, lateral portion of metasternum coarsely punctate . . . . . 4  
 - Prohypomera without microsculpture, lateral portions of metasternum smooth . . . . . 5  
 4 Mesepisterma with microsculpture . . . . . *C. sibiricum* Solsky  
 - Mesepisterma without microsculpture . . . . . *C. yunnanum* (Achard)  
 5 Elytra with distinct puncture rows. Metacoxal process with evenly concave apical edge . . . . . *C. siamense* Löbl  
 - Elytra without distinct puncture rows. Metacoxal process with tridentate apical edge . . . . . *C. sichuanum* sp. n.

### **Cyparium mikado** Achard

Material examined. China, Beijing, Badaling, 13.XII.1993, G. de Rougemont, 1 (MHNG); Shaanxi, Qin Ling Shan, 110°06'E, 34°27'N, Hua Shan, north Valley, 1200-1400 m, 118 km E Xian, 18-20.VIII.1995, M. Schülke, 1; same data but leg. D. W. Wrase, 1; same but leg. A. Pütz, 3 (PCAP, PCMS, MHNG).

*Distribution.* Japan; China: Beijing and Shaanxi.

*Comments.* This species is locally common in Japan and very active (personal observation). It may be easily distinguished from its Asian congeners by the pronotum and elytra with microsculpture, in combination with the uniformly dark and large body. The shape of the parameres and the structures of the internal sac of the aedeagus (Figs 1 to 3) are also diagnostic.

### **Cyparium montanum** Achard

Material examined. China, Yunnan, Jizu Shan, 25°50'N 100°21'E, 2500-2700m, 6-10.VII.1994, V. Kubán, 9 (NHMB, MHNG).

*Distribution.* North India; Bhutan; China: Yunnan.

*Comments.* This species may be easily distinguished by the elytral colour pattern.

### **Cyparium siamense** Löbl

Fig. 7

Material examined. China, South Yunnan, Mengyang Nat. Res. ca 500m, 14.IX.1994, S. A. Kurbatov, litter, 3 (MHNG).

*Distribution.* China: Yunnan.

*Comments.* The specimens of China are slightly smaller than those from Thailand. They differ also in having the elytral margin keels entirely exposed, and the aedeagi 0.90-0.92 mm long.

### **Cyparium sibiricum** Solsky

Figs 1-3

Material examined. China, Yunnan, Heishui, 35km north Lijiang, 27°13'N, 100°19'E, 18.VI.-4.VII.1993, S. Bečvář, 10 (MHNG); North Yunnan, Lijiang, 2600m, 30.VI.-2.VII.1990, L. & M. Bocák, 1 (NHMB); Sichuan, Ganzi Pref., Daxue Shan, 101°57'E 30°03'N, north Kanding, 2600-2700m, 22-24.V.1997, A. Pütz, 1 (PCAP); South Sichuan, 20km S Muli (Bowa), 101°13'E, 27°45'N, 3500m, 29.VI.1998, M. Bocák, 1 (BMNS); Shaanxi, Qin Lin Shan, 100°06'E 34°27'N, Hua Shan, north valley, 1200-1400m, 118km E Xian, 18.-20.VIII.1995, M. Schülke, 1 (MHNG).

*Distribution.* Russia: Siberia, Transbaikal, Far East Russia; China: Shaanxi, Sichuan, Yunnan.

*Comments.* The specimens of China possess finer and shorter elytral puncture rows than the specimens from Russia. *Cyparium tenenbaumi* Pic from Siberia is very similar to, and likely just an infrasubspecific form of *C. sibiricum*. More material is needed to examine the validity of *C. tenenbaumi*.

### **Cyparium yunnanum** (Achard)

Type material examined. Lectotype ♂ and paralectotype ♀, labelled Ht. Yunnan, Tali / Type (red) / *Cyparium yunnanum* n. sp. J. Achard det Type (handwritten by J. Achard) / Mus. Nat. Pragae Inv. 18714 (lectotype) and Inv. 18713 (paralectotype) (NMPC) - by present designation.

Additional material. China, Yunnan, 1 ♀ (MHNG).

*Distribution.* China: Yunnan.

*Comments.* This species possesses following diagnostic characters: Length 1.8-1.9 mm. Body black, not iridescent. Apex of abdomen, femora, tibiae and antennal club brown. Antennal segments 1 - 6 and tarsi ochraceous. Prohypomera dull, with conspicuous microsculpture. Mesepisterna smooth. Metasternum without microsculpture. Most of middle portion of metasternum smooth, fine punctures near intercoxal process. Lateral portions of metasternum distinctly punctate, puncture diameters smaller than puncture intervals. Abdominal segments with microsculpture consisting of punctures. First exposed sternite punctate as lateral portions of metasternum, and with laterobasal row of elongate pits. Aedeagus very similar to that in *C. sibiricum*.

### **Cyparium sichuanum** sp.n.

Figs 4-6

Holotype ♂: China, Central Sichuan, Wolong Nat. Res., 100m, 24.V.1994, in bamboo litter, S. A. Kurbatov (MHNG).

*Description.* Length 3.7 mm, width 2.3 mm. Body black, frons and abdominal apex dark brown, legs reddish-brown, palpi and antennal segments 1 to 6 yellowish, segments 7 to 11 light brown. Pronotum and elytra without microsculpture, not iridescent. Head with frons finely punctate, at narrowest point 0.17 mm. Antennal segments 3 and 5 evenly long, segment 4 distinctly shorter, segment 6 1.4 times as long as wide, segment 7 about as long as wide, segments 8 to 10 gradually wider, each wider than long. Pronotum with lateral edges barely sinuate near base, lateral keels not exposed in dorsal view, punctation irregular, partly very fine, diameters of largest punctures usually much smaller than puncture intervals. Exposed portion of scutellum wider than long. Elytra with adsutural areas impressed and flat; lateral margin keels concealed at level of maximal width and near apex (dorsal view); discal punctation very irregular, four irregular, fairly coarse puncture rows hardly distinguishable; punctation

Figs 1-7

Aedeagi in *Cyparium*: 1 to 3. *C. sibiricum* Solsky, internal sac extruded, parameres (2) and internal sac (3) in detail; 4 to 6. *C. sichuanum* sp. n., paramere (5) and internal sac (6) in detail; 7. *C. siamense* Löbl, internal sac. Scale bars = 0.1 mm in figs 2, 3, 5, 6, 7; = 0.2 mm in figs 1 and 4.



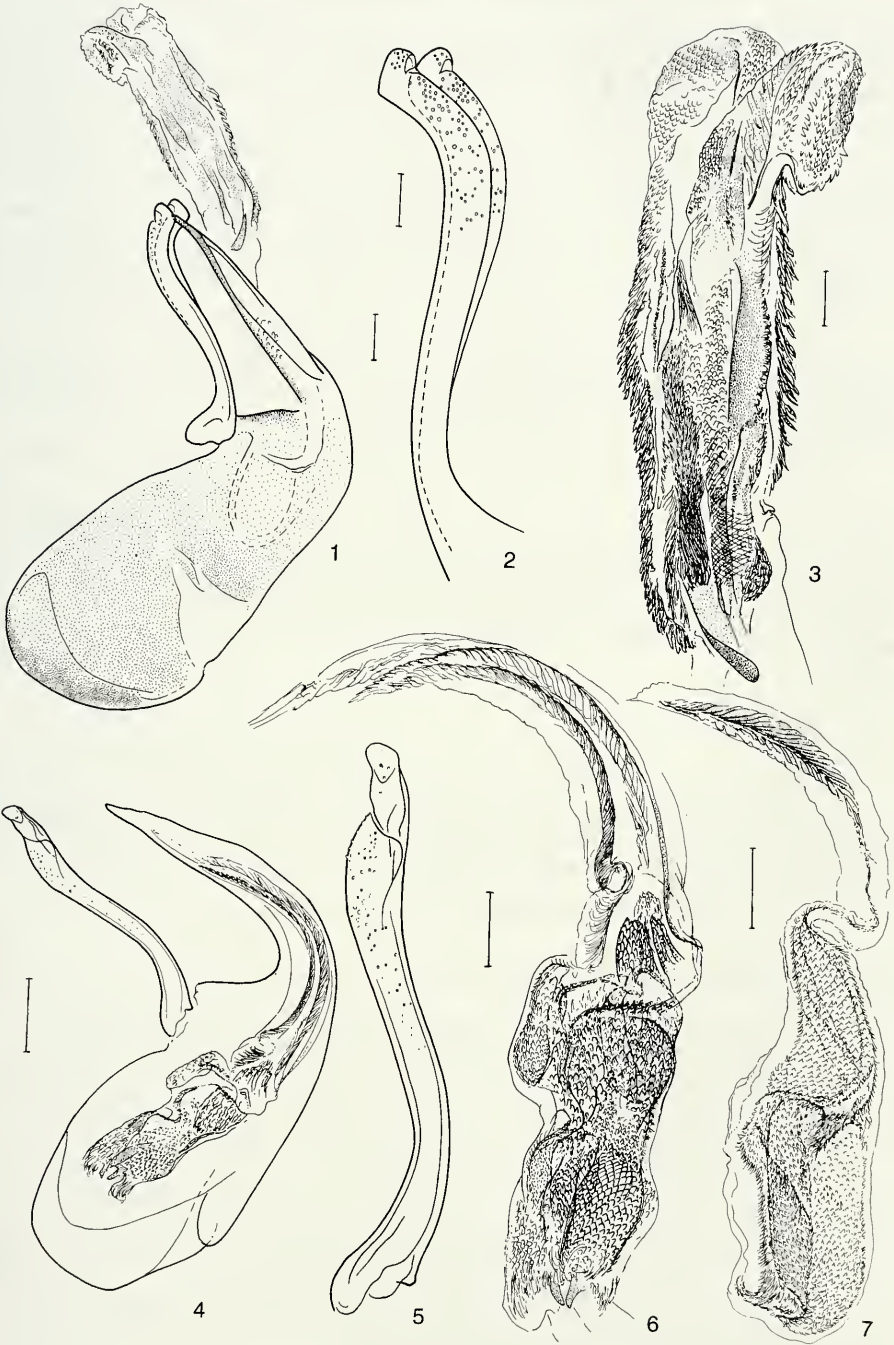

extremely fine between puncture rows, along lateral edges, and at base; punctation coarse and dense on apical third of elytra and on area posterior humeral protuberance. Coarse elytral punctures larger than largest pronotal punctures. Prohypomera smooth. Mesepisterna and metasternum extremely finely punctate. Median portion of metasternum slightly raised in middle, with two wide and shallow admesal impressions. Metacoxal process raised in middle, with apical edge tridentate, more prominent in middle than at angles. Exposed abdominal segments with mesh-like microsculpture, in addition to brickwall-like microsculpture of intersegmental membranes. Propygidium and pygidium almost evenly finely punctate. First exposed sternite with fairly coarse and sparse punctation, following sternites very finely punctate. Tibiae slightly curved.

Male sexual characters. Segments 1 to 3 of protarsi and mesotarsi almost evenly wide, distinctly wider than segments 4 and 5. Aedeagus (Figs 4 to 6) 1.22 mm long. Apical portion of median lobe perpendicular to basal bulb. Parameres sinuate, widest subapically (lateral view), with apical lobe. Internal sac with membranes forming scale-like and denticulate structures, robust sclerites absent.

*Comments.* This species would key to the couplet «5» in the key of the Asian species of *Cyparium* (LÖBL 1990a), together with *C. laevisternale* Nakane. It may be distinguished from *C. laevisternale* by the elytral punctation which is mostly coarse, and by the shape of the metacoxal process which is concave apically and not raised medially in *C. laevisternale*. The internal sac of the aedeagus resembles that of *C. siamense* (Fig. 7), although it is more complex. The parameres are not lobed in *C. siamense*.

### Ascaphium Lewis

This genus comprises seven described species which are keyed in LÖBL (1992). Three of them occur in Japan, two are described from China (one of them described originally as a variety), one from Vietnam, and one from Nepal. Three unidentified species from Taiwan and Burma are represented in collection of the MHNG. Two additional, new species from China are described below.

#### KEY TO THE SPECIES OF *ASCAPHIUM* OF CHINA

- 1 Large species 6.5-7 mm long. Antennal segment 7 about 2 times as long as wide. Elytra with puncture rows almost reaching posterior tenth of elytra ..... *A. sinense* Pic
- Smaller species 5-6 mm long. Antennal segment 7 about 1.6 times as long as wide. Elytra with puncture rows ending far anterior apical tenth of elytra ..... 2
- 2 Antennae uniformly brown, or segments 7 to 10 slightly darkened. Elytra with four almost equal, long, discal puncture rows and one short lateral puncture row starting about at mid-length of elytral disc ..... *A. minus* Pic
- Antennae with segments 7 to 10 much darker than segments 1 to 6 and 11. Elytra with discal puncture rows different ..... 3

- 3 Elytra with four discal puncture rows not or hardly impressed, without additional short lateral row . . . . . *A. alticola* sp. n.  
 - Elytra with four discal puncture rows distinctly impressed and two lateral, very short additional puncture row . . . . . *A. irregulare* sp. n.

### **Ascaphium minus** Pic

Type material examined. Lectotype ♂ labelled Kuatun Fukien China 18.11.46 (Tchung Sen.) / var. *minor* mihi (handwritten by Pic) (MHNG); paralectotypes 1♂ and 1♀ labelled as the lectotype but from 25.4. and 10.5.46, respectively (MHNG) - by present designation.

Additional material. Same data but from 14.9.46 and without the original identification labels, 4 (MHNG).

*Distribution.* China: Fujian.

*Comments.* Specimens without Pic's original identification labels are likely syntypes but in doubt they are not considered as such. Additional specimens from Kuatun are in MNHN. The previous spelling "*minor*" combined with a neuter genus name is incorrect.

### **Ascaphium sinense** Pic

Type material examined. Lectotype ♂ labelled Kuatun Fukien China 6.12.46 (Tschung Sen.) / 9739 E91/ Type *Ascaphium sinense* n. sp. (red handwritten) (NHRS); paralectotypes 3♂, 2♀ with same label data as the lectotype but from 6.3., 2.4., 22.10., 2.11. and 18.11.46, respectively. Each bearing Pic's handwritten label *Ascaphium sinense* (MHNG) - by present designation.

Additional material. From the same locality but from various dates in 1946, 29 (MHNG).

*Distribution.* China: Fujian.

*Comments.* As under *A. minus*.

### **Ascaphium irregulare** sp.n.

Figs 8-10

Holotype ♂: China, Yunnan, 25°58'N, 100°21'E Jizu Shan, 2500-2700m, 6-10.VII.1994, V. Kubán (MHNG).

Paratypes: same data as holotype, 1♂, 4♀ (MHNG).

*Description.* Length 5.0-5.5 mm. Head, body, femora and tibiae uniformly black. Palpi, antennal segments 1 to 6 and 11, tarsi and apical abdominal segments light brown to ochraceous. Antennal segments 7 to 10 blackish. Frons at narrowest point 0.43-0.46 mm, with punctuation irregular, fine and sparse anteriorly, gradually denser and coarser toward neck. Neck smooth, impunctate, not microsculptured dorsally. Antennae moderately long; segment 5 about 3 times as long as wide; segment 6 2.5 times as long as wide, club stout; segments 7, 8, 9 and 11 each 1.5 to 1.6 times as long as wide; segment 10 about 1.2 times as long as wide. Pronotum at base 2.0-2.2 mm wide; lateral edges oblique in basal half, arcuate in apical half; antebasal puncture row slightly impressed, contiguous in middle, consisting of coarse punctures; discal punctuation sparse and very fine. Elytra uneven, somewhat flattened posterior basal fourth, impressed laterally and apically. Each elytron with four uneven discal puncture rows situated in relatively wide impressions, and with two additional lateral puncture rows consisting each of two to six coarse punctures. Two inner puncture rows straight.

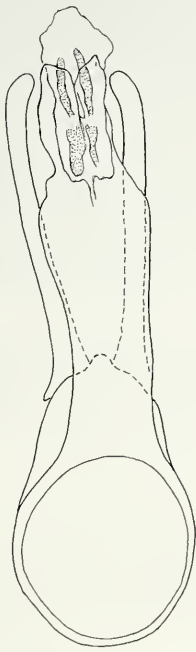

8



9

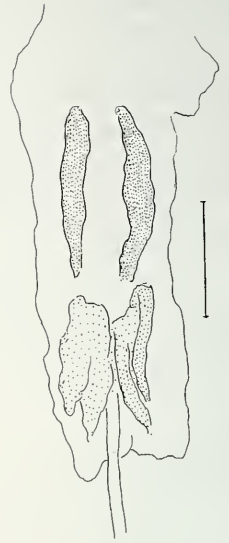

10

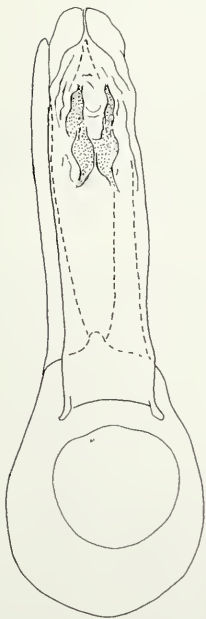

11

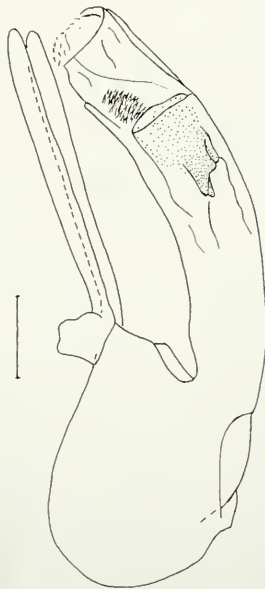

12



13

starting distant from base and ending usually anterior mid-length of elytron; third puncture row sometimes interrupted, starting usually at base and ending posterior mid-length of elytron; fourth puncture row starting at base and curved, or starting posterior base, straight, ending near mid-length of elytron. Remaining elytral punctation very fine. Metasternum with two shallow, elongate medio-apical impressions. First exposed abdominal sternite with mediobasal protuberance; microsculpture absent, except near apical edge. Microsculpture obsolete on following three sternites, consisting of extremely fine striae on apical abdominal segments. Protibiae straight, mesotibiae and metatibiae slightly curved.

Male sexual characters. Segments 1 to 3 of protarsi distinctly widen. Aedeagus (Figs 8 to 10) 1.25-1.35 mm long. Median lobe with apical portion curved, widen toward tip; basal process large, prominent. Parameres diverging apically, curved and slightly widen at tip. Internal sac with asymmetrical complex of subapical sclerites joined to two strongly sclerotized rods.

*Comments.* This species is characterized by the pattern of the elytral puncture rows which are short, irregular, and impressed. Additional diagnostic characters are: antennal segments 7 to 10 strongly darkened and metasternum with two shallow medio-apical impressions. See also comments under *A. alticola*.

### ***Ascaphium alticola* sp. n.**

Holotype ♀: China West Sichuan, 29°35'N 102°00'E 2900-3200m, Gonggashan-Hailuogou, 3-6.VII.1994, J. Farkač & D. Král (MHNG).

Paratype ♀: same data as holotype (MHNG).

*Description.* Length 6.3 mm. Colour as in *A. irregulare*. Frons at narrowest point 0.48 mm, with punctation very irregular, consisting of more or less large punctures mostly smaller than intervals between them. Largest punctures situated near neck. Neck entirely microsculptured, with few fine punctures in middle of dorsal surface. Antennae moderately long, with segment 5 about 3 times as long as wide; segment 6 twice as long as wide; club stout; segment 7 1.6 times as long as wide; segment 8 as wide as and slightly shorter than 7, about 1.4 times as long as wide; segments 9 and 10 evenly large, each 1.6 times as long as wide, slightly wider than segments 7 and 8; segment 11 1.6 times as long as wide. Pronotum at base 2.2 mm wide; lateral edges oblique in basal half, arcuate in apical half; antebasal puncture row slightly impressed laterally, contiguous in middle, consisting of fairly coarse punctures; discal punctation very fine. Elytra slightly flattened or impressed between basal fourth and mid-length, with uneven, inflexed sides. Each elytron with four discal puncture rows: first and second rows short, straight, not or slightly impressed, starting just posterior basal fifth and ending about at level of mid-length of elytron; third puncture row distinctly

---

### FIGS 8-13

Aedeagi in *Ascaphium* and *Episcaphium*; 8 to 10. *A. irregulare* sp. n., internal sac (10) in detail; 11 to 13. *E. catenatum* sp. n., internal sac (13) in detail. Scale bars = 0.1 mm in figs 10 and 13, = 0.2 mm in figs 8, 9, 11 and 12.

impressed, slightly oblique, approximate to base, ending just posterior middle third of elytral length; fourth puncture row deeply impressed, curved, starting posterior humeral protuberance, ending slightly anterior apical third of elytron. Punctuation very fine between and posterior puncture rows. Metasternum with two median striae shallow, approximate, diverging posteriorly. First exposed abdominal sternite with mediobasal protuberance; microsculpture consisting partly of extremely fine punctures, partly forming more distinct mesh-like pattern and transverse striae. Following sternites with microsculpture consisting of meshes and/or transverse striae. Protibiae straight, mesotibiae and metatibiae slightly sinuate.

*Comments.* This species is very similar to *A. irregulare* from which it may be distinguished by the pattern of the elytral puncture rows and by the metasternal striae diverging posteriorly.

### **Episcaphium** Lewis

This genus comprises four species, from Japan, Nepal, East Malaysia, and Sri Lanka. The collections coming from China include three new species which may be easily distinguished by their colour pattern.

#### KEY TO THE SPECIES OF *EPISCAPHIUM*

- |   |   |                                   |
|---|---|-----------------------------------|
| 1 | Head, pronotum and elytra uniformly black . . . . .   | 2                                 |
| - | Colour pattern different . . . . .  | 4                                 |
| 2 | Abdomen uniformly black . . . . .   | 3                                 |
| - | Abdomen ochraceous, elytra without puncture rows . . . . .  | <i>E. strenuum</i> sp. n.         |
| 3 | Elytra with fine puncture rows, without large basal protuberance. Metasternum not microsculptured . . . . .                           | <i>E. catenatum</i> sp. n.        |
| - | Elytra without puncture rows, with large basal protuberance. Metasternum with microsculpture consisting of transverse striae. . . . . | <i>E. callosipenne</i> (Achard)   |
| 4 | Elytra uniformly reddish or ochraceous . . . . .  | 5                                 |
| - | Elytra with one or two dark transverse fasciae . . . . .  | 6                                 |
| 5 | Head, or head and pronotum, black . . . . .   | <i>E. semirufum</i> Lewis         |
| - | Head, pronotum and elytra reddish . . . . .   | <i>E. uniforme</i> Löbl           |
| 6 | Elytra with dark central and apical fasciae; puncture rows absent. Pronotum reddish . . . . .   | <i>E. saucineum</i> (Motschulsky) |
| - | Elytra with dark apical transverse spot and four puncture rows. Pronotum reddish, often with pair of dark basal spots . . . . .       | <i>E. haematoides</i> sp. n.      |

### **Episcaphium catenatum** sp. n.

Figs 11-13

Holotype ♂: China, Central Sichuan, Wolong Nat. Res., 1500m, 21.V.1994, S. A. Kurbatov (MHNG).

Paratypes: same data as holotype, 2 ♂, 3 ♀ (MHNG).

*Description.* Length 5 mm. Body and legs black, antennal segments 1 to 6, tip of antennal segment 11, palpi and apex of abdomen dark brown. Frons at narrowest point

0.42 mm, with punctuation sparse and fine anteriorly, becoming more dense and coarse posteriorly, puncture diameters larger than puncture intervals near neck. Punctuation fine and dense on tempora, fine and sparse on neck. Neck microsculptured, except on smooth centre. Antennae short, club segments stout. Antennal segment 5 distinctly longer than segment 6 (index 28:22), almost 2 times as long as wide; segment 6 about 1.4 times as long as wide; segments 7 and 8 each about 1.3 times as long as wide; segments 9 and 10 as long as wide or slightly longer than wide; segment 11 about 1.5 times as long as wide. Pronotum at base 1.9 mm wide, with lateral margin sinuate, concave near base, arcuate in apical half; antebasal puncture row irregular, sparse, not impressed laterally, interrupted at middle; discal punctuation sparse and fine. Elytra without impressions, lacking discal grooves or striae, with four discal puncture rows (in addition to adsural, basal, and marginal puncture rows): first to third rows short, ending near mid-length of elytron, fourth row reaching apical fourth of elytron; first and second rows starting distant basal row, third and fourth rows joined to basal row. Punctures forming rows about as large as or slightly larger than punctures forming antebasal pronotal row; remaining punctures very fine. Humeral protuberance hardly distinct. Mesal groove of mesosternal process narrow or absent. Metasternum lacking microsculpture, extremely finely punctate, with median impression shallow, narrowed anteriorly, and with two small oval impressions near metacoxae. Abdominal tergite 7 with distinct lateral striae. Abdominal sternites microsculptured; microsculpture on first exposed sternite consisting of points and transverse striae, that on following sternites mesh-like and striate. First exposed sternite very finely and sparsely punctate. Tibiae slightly curved.

Male sexual characters. Segments 1 to 3 of protarsi distinctly enlarged. Aedeagus (Figs 11-13) 1.35-1.43 mm long. Median lobe with curved, cylindrical apical portion, and robust, prominent ventral process. Compression plate small. Parameres straight in lateral view, slightly arcuate in dorsal view. Internal sac with robust, apically bifid sclerite joined to pair of vertical laminae and to subapical lobe formed by flat denticles. Apical portion of internal sac covered by very fine spine-like structures oriented proximally.

*Comments.* This species may be distinguished from its congeners, *E. callosipenne* excepted, by the uniformly black body. It differs notably from *E. callosipenne* by the absence of the metasternal microsculpture, shape of the elytra and size and shape of the segments of the antennal club.

### ***Episcaphium strenuum* sp. n.**

Figs 14-17

Holotype ♂: China, Yunnan, 27°06'N 115°15'E, Yulonshan, 3000-3500m, Camaizi pass, 18-25.VII.1990, V. Kubán (MHNG).

Paratypes: Sichuan, Gongga Shan, Hailuogou, 29°35'N 102°00' E, in front of Glacier 1, 2800m, 9.VII.1996, A. Smetana, 1 ♂ (MHNG); Sichuan, Daxue Shan, Gongga Shan, Hailuogou Glacier Park, above Camp III, 30.V.1997, A. Pütz, 1 ♂ (PCAP); Yunnan, Heishui, 35 km N Lijiang, 27°13'N, 100°19'E, 18.VI.-4.VII.1993, S. Bečvář, 3 ♀ (MHNG); same but 1-19.VII.1992, 1 ♀; Yunnan, Jizu Shan, 2500-2700m, 25°58'N 100°21'E, 6-10.VII.1994, 1 ♀ (MHNG).

*Description.* Length 6.5-7.5 mm. Head, thorax, elytra and legs, tarsi excepted, black. Abdomen and tarsi reddish-brown or ochraceous. Antennae very dark brown to

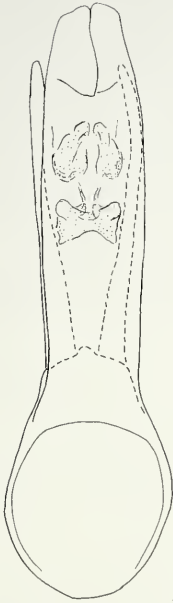

14



15



16

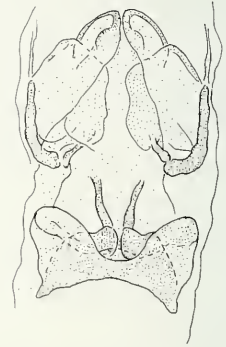

17

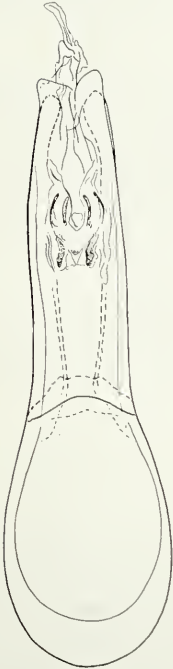

18

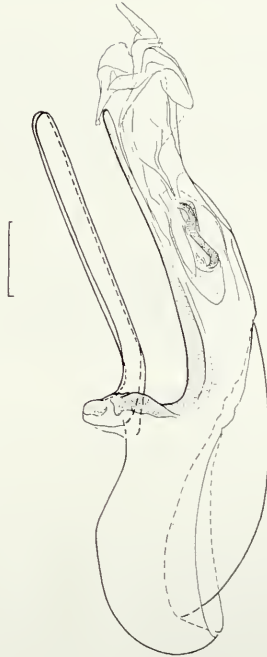

19

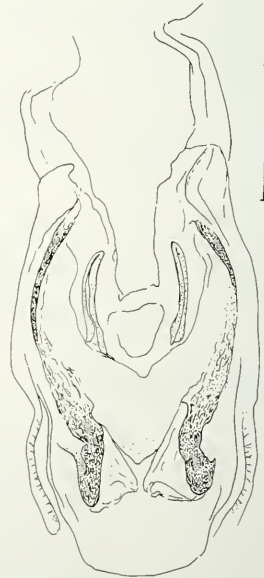

20



blackish. Frons at narrowest point 0.50-0.60 mm wide, with punctation irregular, mostly coarse, fine anteriorly, dense along eye edges, at centre and near neck, sparse on admesal and anterior areas. Frontal punctures mostly much larger than intervals, as large as or smaller than intervals on surface sparsely punctate. Tempora finely punctate. Vertex sparsely and mostly finely punctate, with distinct microsculpture consisting of striae, smooth on small medio-anterior area. Antennae long, club with stout segments. Antennal segment 5 almost 4 times as long as wide; segment 6 distinctly shorter and hardly wider than segment 5, about 2.5 to 3 times as long as wide; segments 7 and 8 evenly wide, 8 slightly shorter than 7, 9 and 10; segment 7 about 1.8-1.9 times as long as wide; segments 8 and 9 each about 1.5-1.6 times as long as wide; segments 9 to 11 becoming gradually, slightly wider, 9 about 1.5-1.6 times as long as wide, 10 1.4 times as long as wide, 11 about 1.6-1.7 times as long as wide. Pronotum at base 2.2-2.4 mm wide, with lateral margin hardly sinuate, antebasal puncture row almost even, not or hardly interrupted at middle, slightly impressed laterally; punctation on disc rather dense and fine. Elytra with small, shallow, mediolateral impression and larger apical impression, lacking discal grooves, striae, without trace of puncture rows; punctation very fine, finer than that on pronotum. Humeral protuberance low. Mesosternal process without mesal groove. Metasternum extremely finely punctate, lacking microsculpture, with medio-apical impression shallow, narrowed anteriorly, and two small impressions near metacoxae; apical edge of metacoxal process slightly concave. Abdominal tergite 7 with distinct lateral striae. Abdominal sternites very finely punctate. First exposed sternite with punctation very fine and sparse, becoming denser mediobasally, and with microsculpture consisting of punctures. Following sternites with distinct microsculpture consisting of striae. Tibiae slightly curved.

Male sexual characters. Segments 1 to 3 of protarsi widen. Aedeagus (Figs 14-17) 2.05-2.10 mm long. Median lobe very weakly widen toward mid-length, almost evenly wide, sinuate and curved in lateral view. Compression plate large. Parameres slender, slightly curved in dorsal view, straight in lateral view. Internal sac with complex sclerites forming rods and plates, membranes bearing spine-like structures visible only while extruded.

*Comments.* This species may be easily distinguished from its congeners by the colour pattern.

### ***Episcaphium haematoides* sp. n.**

Figs 18-20

Holotype ♂: China, Yunnan, Heishui 35km west Lijiang, 27°13'N 100°19'E, 1-19.VII.1992, S. Bečvář (MHNG).

Figs 14-20

Aedeagi in *Episcaphium*; 14 to 17. *E. strenuum* sp. n., internal sac (16 and 17) in detail, and extruded (17); 18 to 20. *E. haematoides* sp. n., internal sac (20) in detail. Scale bars = 0.1 mm in figs 16, 17 and 20, = 0.2 mm in figs 14, 15, 18 and 19.

Paratypes: as holotype, 4 ♂, 4 ♀, 64 (MHNG, NHMB); same but 18.VI.-4.VII.1993, 127 (MHNG); Yunnan, Yulong Mts, 3900m, 27°10'N 100°13'E, 16-19.VI.1993, Bolm, 1 ♂ (NHMB); Yunnan, Jizu Shan, 2500-2700m, 25°58'N 100°21'E, 6-7.VII.1994, V. Kubán, 1 ♂, 1 ♀ (MHNG); Habashan, southeastern slope, 27°20'N 100°11'E, 3-6.VI.1995, S. Bečvář, 20 (MHNG, NHMB); same but 2000-3000m, 10-13.VII.1992, V. Kubán, 1 ♂ (MHNG); Yunnan, Habashan, eastern slope, 3800-4600m, 27°19'N 100°08'E, 15.VII.1992, D. Král, 1 (MHNG); Sichuan, Sabde, ca 3000m, 1-3.VII.1992, R. Dunda, 1 (MHNG).

*Description.* Length 4.8-5.5 mm. Head black. Pronotum ochraceous or reddish, usually with two small, well delimited black spots situated between antebasal puncture row and basal edge, near lateral edges. Elytra as pronotum ochraceous or reddish, but each with an apical transverse black spot not touching lateral and sutural edges. Abdomen ochraceous or reddish with apical segments slightly lighter. Most of ventral surface ochraceous or reddish. Prosternum, prohypomera along posterior edge, mesosternum, mesepisterna, coxae, femora and tibiae black. Tarsi dark brown to blackish. Antennae with segments 1 to 6 very dark, almost black, club black. Frons at narrowest point 0.45-0.48 mm wide, with punctation irregular, mostly sparse and fine, denser and more coarse on centre and near neck. Punctures mostly smaller than intervals between them, some coarse punctures larger than intervals. Tempora impunctate. Vertex finely and sparsely punctate, lacking microsculpture. Antennae moderately long, with club stout. Antennal segment 5 2.3-2.4 times as long as wide; segment 6 shorter and stouter than segment 5, about 1.3 times as long as wide; segments 7 to 10 becoming gradually, slightly wider; segments 7, 9 and 10 each as long as segment 5; segment 7 slightly longer than wide; segment 8 slightly shorter than segment 7 and slightly wider than long; segments 9 and 10 each slightly wider than long; segment 11 about 1.3-1.4 times as long as wide. Pronotum as base 1.9-2.3 mm wide, with lateral margin somewhat rounded, antebasal puncture row interrupted at middle, slightly impressed laterally, discal punctures fairly sparse and very fine. Elytra lacking lateral and apical impressions, with four discal puncture rows consisting of evenly fine punctures, or punctures becoming finer posteriorly. Puncture rows starting posterior basal fifth or fourth of elytron and ending far anterior apical edge. Inner puncture row parallel to adsutural stria, outer puncture rows slightly oblique. Mesosternal process with raised, ridge-like edges, flattened in middle. Metasternum extremely finely punctate, lacking microsculpture, median impressions extremely shallow or absent. Abdominal tergite 7 with distinct lateral striae. Abdominal sternites very finely and sparsely punctate. Lateral portion of first exposed sternite with microsculpture consisting of punctures, median portion without microsculpture. Following three sternites with microsculpture consisting of transverse striae. Tibiae curved.

Male sexual characters. Segments 1 to 3 of protarsi distinctly widen. Aedeagus (Figs 18-20) 1.45-1.55 mm long. Median lobe narrowed apically, inflexed and slightly sinuate in lateral view. Basal process small, slightly prominent. Compression plate large. Parameres slightly arcuate in dorsal view, almost straight posterior curved base in lateral view. Internal sac with two median pairs of sclerotized rods, inner rods much smaller than outer rods.

*Comments.* This species may be easily distinguished by the colour pattern.

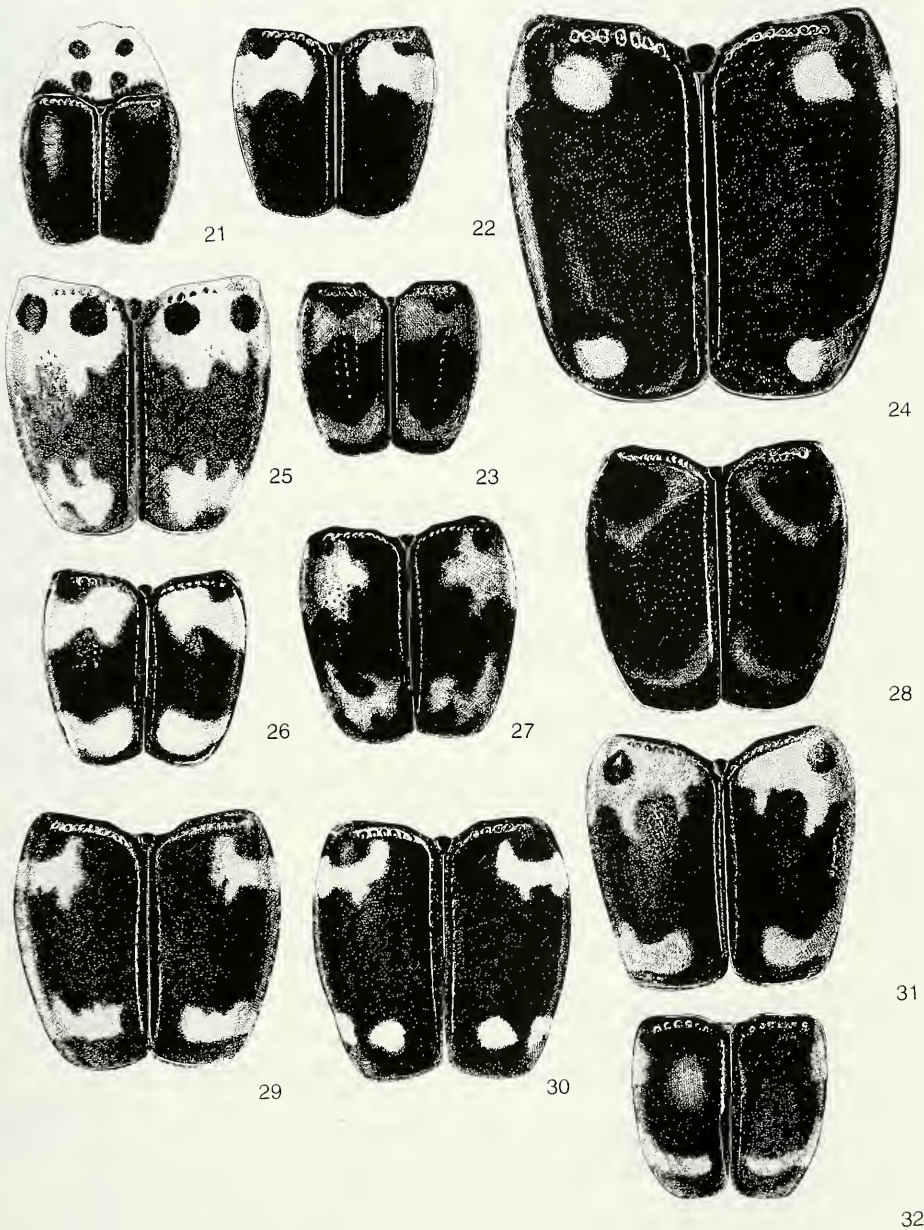

FIGS 21-32

Colour pattern in *Scaphidium*: 21. *S. melli* Löbl; 22. *S. unifasciatum* Pic; 23. *S. sinense* Pic; 24. *S. vernicatum* (Pic); 25. *S. klapperichi* Pic; 26. *S. delatouchei* Achard; 27. *S. yunnanum* Fairmaire; 28. *S. lunare* sp. n.; 29. *S. becvari* sp. n.; 30. *S. kurbatovi* sp. n.; 31. *S. stigmatinotum* sp. n.; 32. *S. sichuanum* sp. n.

**Scaphidium** Olivier

This genus comprises 257 species currently recognised as valid, distributed in major geographic realms with notable absence from New Zealand and oceanic islands. So far, eleven species of *Scaphidium*, including *S. chinense* Li, were described or recorded from China. With the material examined, this number is raised to 24, with eight species described as new.

The description of *S. chinense* Li from Heilongjiang is inadequate and its type material is not available for study. Therefore, this species is not treated in the present paper.

KEY TO THE SPECIES OF *SCAPHIDIUM* OF CHINA

- |    |  |  |
|----|--|--|
| 1  | Pronotum and elytra concolorous . . . . .  | 2                                      |
| -  | Pronotum and/or elytra with distinct colour spots or fasciae, or pronotum much lighter than elytra . . . . .   | 6                                      |
| 2  | Body uniformly ochraceous . . . . .  | <i>S. vicinum</i> Pic                  |
| -  | Pronotum and elytra entirely black, or with metallic luster . . . . .  | 3                                      |
| 3  | Pronotum and elytra with metallic luster, elytra without discal puncture rows . . . . .  | 4                                      |
| -  | Pronotum and elytra without metallic luster, elytra with discal puncture row . . . . .   | <i>S. fukiense</i> Pic                 |
| 4  | Abdomen entirely black. Length 4.5-5.5 mm . . . . .  | 5                                      |
| -  | Head, pronotum and elytra blue, abdomen black with yellowish apical segments. Length 3.7 mm . . . . .  | <i>S. inexpectatum</i> sp. n.          |
| 5  | Prohypomera with microsculpture consisting of striae. Male protibiae evenly stout in apical half . . . . .   | <i>S. jizuense</i> sp. n.              |
| -  | Prohypomera with mesh-like microsculpture. Male protibiae becoming conspicuously stouter toward apical fifth . . . . .   | <i>S. kubani</i> sp. n.                |
| 6  | Elytra uniformly black, with discal puncture rows . . . . .  | 7                                      |
| -  | Elytra with spots or fasciae, puncture rows usually absent . . . . .   | 8                                      |
| 7  | Pronotum uniformly reddish-brown . . . . .   | <i>S. egregium</i> Achard              |
| -  | Pronotum reddish-brown with black base and four small black spots . . . . .  | <i>S. melli</i> Löbl                   |
| 8  | Pronotum bicolorous, or uniformly light . . . . .  | 9                                      |
| -  | Pronotum uniformly black . . . . .   | 11                                     |
| 9  | Elytra black, with two narrow, reddish fasciae. Pronotum black, reddish along lateral edges . . . . .  | <i>S. sinense</i> Pic                  |
| -  | Elytra mostly reddish, spotted, lacking fasciae . . . . .  | 10                                     |
| 10 | Elytra with two large light spots covering most of disc. Pronotum uniformly reddish-brown, or reddish-brown with darkened base. Pygidium uniformly reddish . . . . . | <i>S. flavomaculatum</i> Miwa & Mitono |
| -  | Elytra with five dark spots. Pronotum reddish, with two dark admesal fasciae. Pygidium with dark spot . . . . .  | <i>S. formosanum</i> Pic               |
| 11 | Pronotum with antebasal puncture row not impressed . . . . .   | 12                                     |
| -  | Pronotum with antebasal puncture row impressed . . . . .   | 13                                     |

- 12 Pronotal antebasal puncture row inconspicuous, obsolete laterally. Pronotal punctation coarse, extremely dense on disc, with puncture intervals mostly much smaller than puncture diameters . . . . . *S. stigmatinotum* sp. n.
- Pronotal antebasal puncture row conspicuous. Pronotal punctation fairly fine and dense on disc, with puncture intervals as large as or smaller than puncture diameters . . . . . *S. klapperichi* Pic
- 13 Elytra with two small round subbasal spots and one small apical spot . . . . . *S. vernicatum* (Pic)
- Elytra with subbasal fascia or spot; subapical fascia or spots present or absent . . . . . 14
- 14 Elytra with subbasal spot and subapical fascia . . . . . *S. sichuanum* sp. n.
- Elytra with subbasal fascia, with or without subapical fascia or spots . . . . . 15
- 15 Elytra without subapical fascia or spots . . . . . *S. unifasciatum* Pic
- Elytra with subapical fascia or spots . . . . . 16
- 16 Elytra with two subapical spots, elytral punctation obsolete laterally . . . . . *S. kurbatovi* sp. n.
- Elytra with subapical fascia, elytral punctation distinct laterally . . . . . 17
- 17 Pronotal punctation very fine, almost obsolete. Antennae uniformly brown . . . . . *S. delatouchei* Achard
- Pronotal punctation distinct. Entire antennae, or antennal club, black . . . . . 18
- 18 Elytra with subbasal and subapical fasciae evenly slender, strongly arcuate, extending upto, or almost to, suture . . . . . *S. lunare* sp. n.
- Elytra with subbasal and subapical fasciae uneven, not or slightly arcuate, not extending to suture . . . . . 19
- 19 Male protibiae evenly stout in apical third, with small subapical notch . . . . . 20
- Male protibiae distinctly expanded and angulate in apical third, without subapical notch . . . . . 21
- 20 Male metafemora not expanded subapically . . . . . *S. anurense* Solsky
- Male metafemora expanded subapically . . . . . *S. montivagum* Shirôzu & Morimoto
- 21 Elytra with subbasal fascia slightly larger than subapical fascia, not reaching inner third of elytral width, edentate or weakly bidentate apically; posterior margin of subapical fascia edentate . . . . . *S. becvari* sp. n.
- Elytra with subbasal fascia distinctly larger than subapical fascia, reaching inner third to fifth of elytral width, with distinctly bidentate or tridentate posterior margin . . . . . 22
- 22 Male protibiae becoming moderately stouter toward apical fourth, with ventral margin hardly angulate at widest point. Posterior margin of subapical elytral fascia dentate . . . . . *S. yunnanum* Fairmaire
- Male protibiae becoming strongly stouter toward apical fourth, with ventral margin strongly angulate at widest point. Posterior margin of subapical elytral fascia rounded . . . . . *S. schuelkei* sp. n.

**Scaphidium amurense** Solsky

*Scaphidium tsushimense* Shirôzu & Morimoto, **syn. n.**

*Distribution.* Japan: island Tsushima, pref. Gunma; Far East Russia; Korea; recorded from «Northern China» (LÖBL 1968).

*Comments.* I have not examined the type material of *S. amurense* and *S. tsushimense*. The synonymy is based on the absence of distinguishable characters in specimens I have examined from Korea, Japan (including Tsushima), and Russia, which fit the respective descriptions, and on the fact that only a single species of *Scaphidium* is known to occur in Far Eastern Russia (LAFER 1989) and on the island Tsushima (SHIRÔZU & MORIMOTO 1963).

**Scaphidium delatouchei** Achard

Type material examined. Lectotype, labelled Kouang-Toung (de Latouche) / Museum Paris Chine H. Donckier / Kuantung / Fairmaire det. cf Ann.Fr. 1899 / *Scaphidium* n. sp. [handwritten by M. Pic] / *Scaphidium Delatouchei* m J. Achard det. Type / Type / (MNHN) - by present designation.

Additional material. China. «Yunnan», 1 (MHNG).

*Distribution.* China: Guandong, Yunnan.

*Comments.* The legs of the lectotype have been strongly damaged by dermestids. The specimen from Yunnan is a female likely conspecific with the male lectotype. The shape of the elytral fasciae (Fig. 26) in this species is similar to that in *S. sinense*, but the fasciae are larger in *S. delatouchei*.

**Scaphidium egregium** Achard

Material examined. China, Hong Kong, N:T., V. 1996, G. de Rougemont, 4 (MHNG).

*Distribution.* Singapore; China: Hong Kong.

**Scaphidium flavomaculatum** Miwa & Mitono

Material examined. China, Sichuan, 103°20'E. 29°30'W, Mt. Emei, 500-1200m, 4-18.V.1989, 1 (MHNG).

*Distribution.* China: Sichuan; Taiwan.

*Comments.* I have compared the female specimen from Mt. Emei with a male from «Formosa» (MHNG). Both specimens exhibit the same conspicuous colour pattern, and are very similar in other diagnostic characters. These are the sole specimens which I have seen to fit the original illustration of *S. flavomaculatum*. The location of the type material of *S. flavomaculatum*, as that of other scaphidiines described by MIWA & MITONO (1943), is unknown to me.

**Scaphidium formosanum** Pic

Material examined. China, labelled: Kiangsi, 1929, J. Sedláček, 1 (MHNG).

*Distribution.* Taiwan; China: Jiangxi.

*Comments.* This species is well characterised by the colour pattern, in combination with two discal puncture rows on each elytron. Thus, I have no doubt about the conspecificity of the female from Jiangxi with the Taiwanese specimens examined.

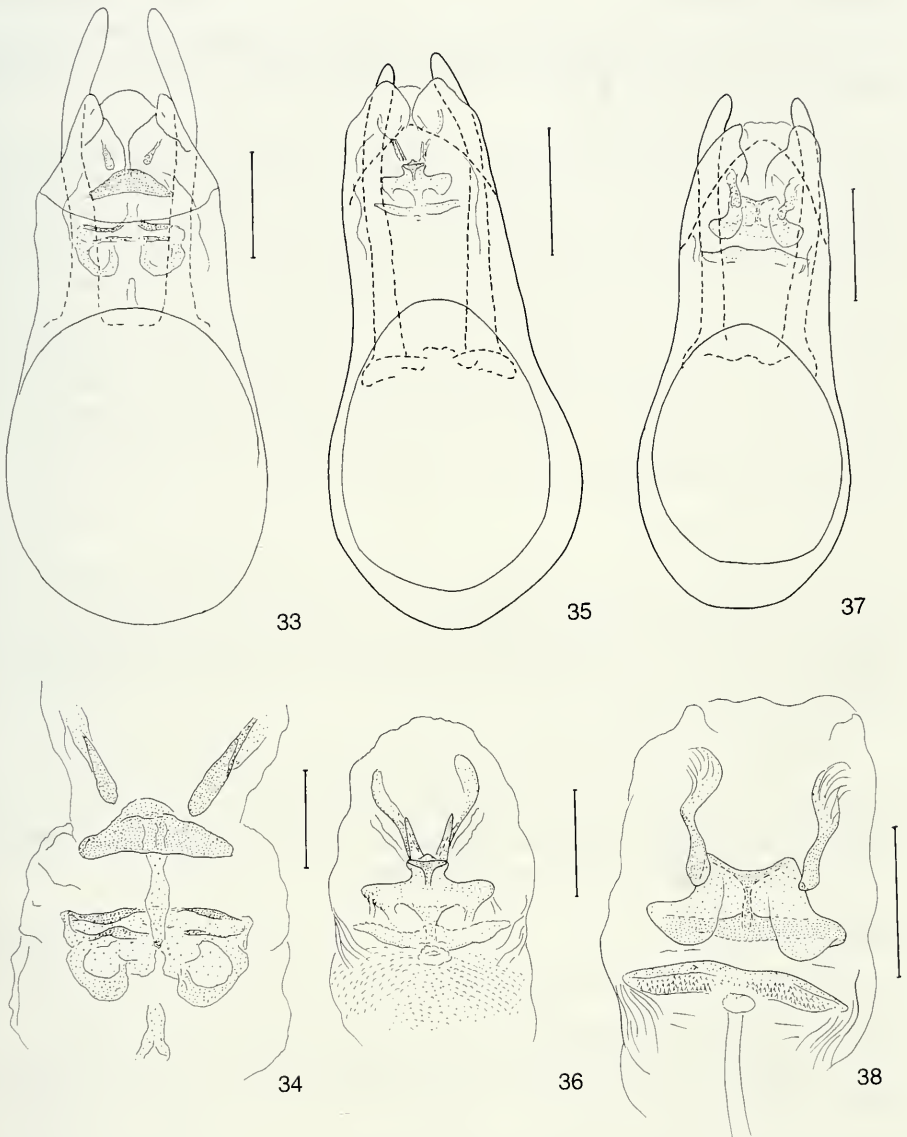

FIGS 33-38

Aedeagi in *Scaphidium*; 33 and 34. *S. fukiense* Pic; 35 and 36. *S. inexpectatum* sp. n.; 37 and 38. *S. kubani* sp. n. Respective internal sacs (34, 36, 38) in detail. Scale bars = 0.2 mm in figs 33, 35, 37; = 0.1 mm in figs 34, 36, 38.

**Scaphidium fukiense** Pic

Figs 33, 34

Type material examined. Lectotype ♂, labelled: Kuantun Fukien China 6.3.46 (Tschung Sen) / Type *Scaphidium fukiense* det. Pic n. sp. [red, handwritten] / 9784 E91 / Lectotype *Scaphidium fukiense* Pic det. Löbl, 1998 (NHRS) - by present designation.

*Distribution.* China: Fujien.

*Comments.* This species may be distinguished by the following characters in combination: body, antennae and legs (including tarsi) entirely black; elytra each bearing one discal row of coarse punctures; remaining discal punctation obsolete; pronotal punctation very fine; prohypomera smooth, without impressions; ventrite I extremely finely punctate, without microsculpture; male metasternum with impressed, coarsely punctate and pubescent median area extended to level of mesocoxae; metasternal pubescence fairly short, recumbent to oblique, not forming setal tufts; metacoxal process not notched; male tibiae long and slender; protibiae and mesotibiae slightly curved, metatibiae straight; profemora lacking obvious sexual characters; male protibiae becoming slightly stouter toward apex, without subapical notch; aedeagus 1.20 mm long, as in Figs 33, 34.

**Scaphidim klapperichi** Pic

Fig. 25

Type material examined. Lectotype ♂, labelled: Kuantun Fukien China 30.5.46 (Tschung Sen) / Type *Scaphidium klapperichi* Pic n. sp. (red handwritten) Lectotype *Scaphidium klapperichi* Pic det. Löbl 1998 (NHRS). Paralectotype ♂, labelled: Kuantun Fukien China 18.5.46 (Tschung Sen.) / *Scaphidium Klapperichi* n. sp. (handwritten by Pic) / paralectotype *Scaphidium klapperichi* Pic det. Löbl 1997 (MHNG) and paralectotype / with same data but from 16.5 (MNHN) - by present designation.

*Distribution.* China: Fujian.

*Comments.* This species is characterized by the shape of the large reddish basal elytral fascia surrounding two small black spots (Fig. 25). In addition, the pronotal antebasal puncture row is not, or barely impressed laterally, and consists of punctures which are much larger than other pronotal punctures.

**Scaphidium melli** Löbl

Fig. 21

Material examined. China, Yunnan, Lijiang, 2600m, 30.VI.-2.VII.1990, L. & M. Bocák, 3 (MHNG, NHMB).

*Distribution.* China: Yunnan.

*Comments.* This species may be easily distinguished by the conspicuous colour pattern of the pronotum (Fig. 21).

**Scaphidium montivagum** Shirôzu & Morimoto

Material from China not examined.

*Distribution.* Japan; China: Jilin.

*Comments.* This species is a member of a group of very similar species (*S. amurense* Solsky, *S. yasumatsui* Shirôzu & Morimoto, *S. takemurai* Nakane), which are distinguished by their aedeagi and the male sexual characters on the legs. It was recorded from China by LI (1992).



**Scaphidium sinense** Pic

Fig. 23

Type material examined. Holotype ♀, labelled: Kuantun Fukien China 10.5.46 (Tschung Sen) / 9820 E91/type *Scaphidium sinense* det. Pic, n. sp. (NHRS).

Additional material. China, Fukien, Kuantun, 14.V.1946, Tschung Sen, 1 ♀ (MHNG).

*Distribution.* China: Fujien.

*Comments.* In contrary to the statement in the description of this species made by Pic (1954), the antennal club is black, with apex of the ultimate segment slightly lighter. *Scaphidium sinense* may be distinguished by the shape of the elytral fasciae (Fig. 23), in combination with the presence of fine discal puncture rows, the pronotum reddish laterally, and the prohypomera with reddish upper portion.

**Scaphidium unifasciatum** Pic

Fig. 22

Material examined. China, labelled «Yunnan Fou», 1 (MHNG).

*Distribution.* China: Yunnan.

*Comments.* This species is unique within the Chinese *Scaphidium* in having a single large, reddish, subbasal fascia on each elytron, while the remaining surface of the body is entirely black (Fig. 22).

**Scaphidium vernicatum** (Pic)

Fig. 24

Type material examined. Lectotype ♂, labelled: Kuantun, Fukien 28.10.46 (Tschung Sen.) / ♂ / Type *Scaphium vernicatum* n. sp. [red, handwritten] / 9822 E91 / Lectotype *Scaphidium vernicatum* (Pic) det. Löbl 1998 (NHRS) and 2 ♀ paralectotypes with the same locality labels, but from 4.5.1946, and identification labels handwritte by Pic (MNHN, MHNG) - by present designation.

Additional material. 1 ♂ labelled China, Prov. Kiangsi (MHNG).

*Distribution.* China: Fujian, Jiangxi.

*Comments.* This species may be easily distinguished from its congeners, except *S. perpulchrum* Csiki, by the large size of the body (length, including head and abdomen: 9.5-11 mm). The colour pattern of *S. vernicatum* is distinctive (Fig. 24).

**Scaphidium yunnanum** Fairmaire

Figs 27, 39, 40

Type material examined. Lectotype ♀ labelled Yunnan A. Davis/Type (MNHN) - by present designation.

Material examined. China, Sichuan, Liziping near Shimian, 200km SW of Ya'an, 27.V.-3.VII.1991, Z. Kejval, 1 (MHNG); South Sichuan, 20km south Muli (Bowa), 101°13'E, 27°45'N, 3500m, 29.VI.1998, M. Bocák, 1 (SMNS); Yunnan, Yulongshan, Ganhaizi Pass, 3000-3500m, 27°06'N, 100°15'E, 18-23.VII.1990, V. Kubán, 2 (MHNG); Yunnan, Yulongshan, Baishui, 2900-3500m, 27°08'N, 100°14'E, 7-12.VII.1990, V. Kubán, 2 (MHNG); Yunnan, Dali, Cangshan, 5.VI.1993, Bolm 1 (MHNG); Yunnan, Gaoligong Mts, 2200-2500m, 24°57'N, 98°57'N, 98°45'E, 8-16.V.1995, O. Semela, 1 (MHNG); Yunnan, Jizu Shan, 2500-2700m, 25°55'N, 100°21'E, 6-10.VII.1994, V. Kubán, 3 (MHNG, NHMB).

*Distribution.* China: Sichuan, Yunnan.

*Comments.* This species may be distinguished by the subbasal elytral fasciae which are large and bidentate or tridentate anteriorly and posteriorly (Fig. 27). The aedeagus is characterized by a pair of flat, strongly arcuate, teeth-like rods situated at each side of a transverse central sclerite of the internal sac (Figs 39, 40).

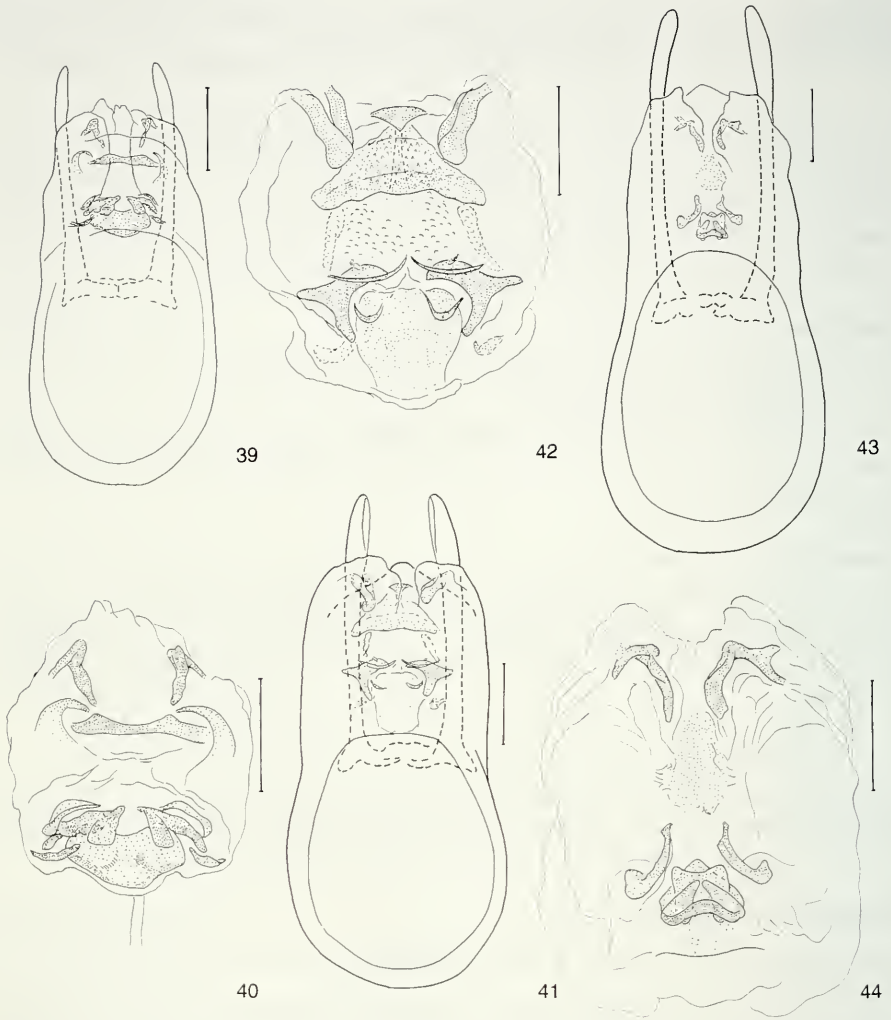

FIGS 39-44

Aedeagi in *Scaphidium*: 39 and 40. *S. yunnanum* Fairmaire; 41 and 42. *S. becvari* sp. n.; 43 and 44. *S. lunare* sp. n. Respective internal sacs (40, 42, 44) in detail. Scale bars = 0.3 mm in figs 39, 41, 43; = 0.2 mm in figs 40, 42, 44.

**Scaphidium inexpectatum** sp. n.

Figs 35, 36

Holotype ♂: China, Yunnan, Gaoliong Mts, 1500-2500m, 25°22'N, 98°49'E, 17-24.V. 1995, O. Semela (MHNG).

*Description.* Length 3.7 mm. Body black. Head, pronotum, elytra, femora and tibiae with blue metallic luster. Abdominal sternites 3 to 6 and tergite 6 black, following abdominal segments yellowish. Tarsi and antennal segments 1 to 6 very dark brown to black, antennal segments 7 to 11 black. Frons and vertex irregularly, fairly coarsely and densely punctate, except for smooth upper portion of frons; smallest width between eyes 0.25 mm. Pronotum hardly raised above level of elytra, moderately inflexed anteriorly, with lateral edges straight in basal half, convexly rounded in anterior half; antebasal puncture row distinctly impressed, not interrupted in middle, discal punctation dense and fairly coarse, consisting of sharply delimited punctures; intervals between punctures mostly as large as, some intervals upto two times as large as puncture diameters. Elytra weakly convex, without humeral protuberance and without any impressions; adsutural area flat anteriorly, raised posteriorly; discal punctation similar to that on pronotum, puncture rows absent; sutural stria punctures about as large as discal punctures, basal stria punctures coarse. Prohypomera with very shallow impressions, very finely punctate, not microsculptured. Mesepisterna smooth. Sternite I lacking microsculpture, with punctation coarser than that on following sternites and on lateral portions of metasternum. Following abdominal segments with microsculpture consisting of punctures. Legs short, tibiae slightly curved.

Male sexual characters. Metasternum impressed in middle, with prominent, slightly rounded metacoxal process. Metasternal pubescence long, raised laterally, recumbent at middle, covering entire median portion of metasternum, mesocoxal process excepted. Profemora with ventral side slightly flattened. Protibiae gradually stouter toward apex, not notched, not expanded subapically. Metafemora without particular sexual characters. Aedeagus (Figs 35, 36) 0.95 mm long. Median lobe moderately narrowed posterior basal bulb, with apex obtuse and inflexed. Parameres subparallel in basal two thirds, curved in apical third, slightly widen near tip. Internal sac with transverse, weakly sclerotized basal plate, central transverse plate joined to oblique lateral sclerites, and with distal protuberance bearing diverging rods.

*Comments.* This species resembles *S. cyanellum* Oberthür, *S. jizuense* and *S. kubani*. It may be easily distinguished by the small size of the body, the prohypomera lacking microsculpture, the male protibiae becoming evenly stouter toward apex and the shape of the sclerites of the internal sac of the aedeagus.

**Scaphidium jizuense** sp. n.

Holotype ♂: China, Yunnan, Jizu Mts, 2800m, 25°58'N, 100°21'E, 30.V.-3.VI.1993, Bolm (MHNG).

*Description.* Length 4.4 mm. With most diagnostic characters as *S. inexpectatum*. It differs as follows: Body, including exposed abdominal segments, blue metallic shining, antennae and legs uniformly black. Frons at narrowest point between eyes 0.30 mm. Pronotum with discal punctation slightly finer, more sparse and more

irregular, intervals between punctures mostly as large as, some upto five times as large as, puncture diameters. Elytra with adsutural area entirely raised, discal punctation notably coarser and denser than that on pronotum. Prohypomera with microsculpture consisting of longitudinal striae becoming obsolete near upper edge. Mesepisterna very finely punctate. Basal and middle portions of sternite I with microsculpture consisting of punctures, latero-apical portion of third sternite transversely striate; laterobasal portions of fourth and fifth sternite with conspicuous longitudinal wrinkles. Legs fairly long. Metasternal process slightly extended, truncate, with a minute notch in middle; entire metasternal pubescence short and recumbent. Protibiae almost straight, parallel-sided in apical half.

*Comments.* This species may be easily distinguished from its similar congeners by the short metasternal pubescence, the base of the abdominal sternites 4 and 5 wrinkled, and the apical half of the male protibiae evenly wide. The aedeagus of the specimen was lost while dissection.

**Scaphidium kubani** sp. n.

Figs 37, 38

Holotype ♂: China, Yunnan, Gaoligong Mts, 1500-2500m, 25°22'N, 98°49'E, 17-24.V.1995, O. Semela (MHNG).

*Description.* Length 5.5 mm. Body black. Head, prohypomera, mesepisterna, lateral portions of metasternum, abdominal tergites, femora and tibiae with blue metallic luster, pronotum and elytra with violet metallic luster. Prosternum, mesosternum and middle portion of metasternum without metallic luster. Tarsi and antennal segments 1 to 6 blackish-brown, antennal segments 7 to 11 black. Frons at narrowest point between eyes 0.33 mm, finely and densely punctate, punctures mostly smaller than intervals between them, smaller than vertexal punctures. Pronotum not raised above level of elytra, moderately inflexed anteriorly, with lateral edges weakly sinuate; antebasal puncture row slightly impressed, not interrupted in middle, discal punctation dense and fine, consisting of punctures sharply delimited, mostly larger than those on frons and 2-3 times smaller than intervals between them. Elytra weakly convex, with adsutural area raised, without humeral protuberance and impressions; discal punctation almost as that on pronotum, distinct puncture rows absent; sutural stria punctures slightly larger than discal punctures; basal stria punctures coarse. Prohypomera impunctate, with mesh-like microsculpture. Mesepisterna very finely punctate. Exposed abdominal segments with even fine punctation and microsculpture consisting of points. Legs fairly long.

Male sexual characters. Metasternum impressed, metacoxal process not extended, truncate. Metasternal pubescence covering most of median portion of metasternum, starting about at level of posterior edge of mesocoxa, short and recumbent at middle and anteriorly, long and erect posteriorly, forming conspicuously long, erect tufts. Profemora slightly expanded anteriorly, with a ridge along anterior edge. Protibiae becoming gradually stouter toward apical fifth, not notched, slightly narrowed from widest point toward apex, with ventral edge arcuate, dorsal edge straight in apical two thirds. Mesotibiae and metatibiae slightly curved, becoming slightly stouter toward

apex. Metafemora lacking obvious sexual characters. Aedeagus (Figs 37, 38) 1.45 mm long. Median lobus parallel posterior basal bulb, gradually inflexed and narrowed toward obtuse tip. Parameres slightly curved, somewhat widen apically. Internal sac with two lateral, vertical laminae, transverse basal rod joined to weakly sclerotized plate, apical lamina strongly sclerotized along mid-line and at posterior edge, and narrowed posteriorly, and two oblique latero-apical rods.

*Comments.* This species may be easily distinguished from its congeners of similar size, except *S. violaceipenne* Pic, by colour pattern. *Scaphidium violaceipenne* differs in having the pronotum raised above the level of the elytra, the discal punctation of the pronotum and elytra much more sparse, the puncture intervals about 10 to 20 times larger than the puncture diameters, the male protibiae evenly slender, the male profemora flattened ventrally, with sharp ventral edges, the aedeagus 1.4 mm long, with the parameres strongly arcuate.

### *Scaphidium becvari* sp. n.

Figs 29, 41, 42

Holotype ♂: China, Yunnan, 27°20'N, 120°11'E, Habashan, 2500-3800m, southeastern slope, 3-6.VI.1995, S. Bečvář (MHNG).

Paratypes: as holotype, 4 ♂, 4 ♀; same but 2000-3000m, 10-13.VII.1992, V. Kubán, 1 ♀ (MHNG); Yunnan, Heishui, 35 km north Lijiang, 27°13'N, 100°19'E, 18.VI.-4.VII.1993, S. Bečvář, 13 ♂, 7 ♀ (MHNG); same but 1-19.VII.1992, 21 ♂, 25 ♀ (MHNG); Yunnan, Weibaoshan, 2800-3000m, 25°12'N, 100°24'E, 29-30.VI.1992, D. Král, 1 ♀ (MHNG); Yulongshan, 3000-3500m, Ganhaizi Pass, 27°06'N, 100°15'E, 18-23.VII.1990, V. Kubán, 5 ♂, 6 ♀ (MHNG, NHMB); same but 18-23.VII.1990, D. Král, 1 ♂, 1 ♀ (MHNG); Yunnan, Yulong Mts, 27°07', 100°13'N, 3400m, 20-21.VI.1993, Bolm 6 ♂, 5 ♀ (MHNG, NHMB); West Sichuan, Daxue Shan, Hailuoguo, Glacier Park (Gongga Shan), Camp 1, 2100m, 29°36'N 102°04'E, 27-31.V.1997, D. V. Wrase, 1 ♀ (PCMS); South Sichuan, 30km NW Muli (Bowa), 101°05'E, 28°07'N, 3500m, 2.VI.1998, M. Bocák, 1 ♂, 1 ♀ (SMNS); South Sichuan, 20km S Muli (Bowa), 101°13'E, 27°45'N, 3500m, 29.VI.1998, M. Bocák, 1 ♀ (SMNS).

*Description.* Length 6-7 mm. Body black, each elytron with two ochraceous fasciae (Fig. 29). Very similar to *S. lunare*, differs by: Elytra with subbasal fascia short and narrow, forming a small arc around humerus, extended from lateral edge about to mid-width of elytron (dorsal view), almost even anteriorly, bidentate posteriorly. Sub-apical fascia almost evenly sinuate, shorter than interval between posterior margin and apical edge of elytron. Frons very sparsely punctate, at narrowest point 0.42-0.45 mm.

Male sexual characters. Legs and metasternum as in *S. lunare*. Aedeagus (Figs 41, 42) 1.75-1.90 mm. Median lobe subparallel posterior basal bulb, with tip prominent, rounded and inflexed. Parameres parallel or slightly converging apically, with inner side flattened apically and sharply delimited. Internal sac with basal sclerites consisting of round central plate bearing slender apophysis, pair of robust trifid sclerites joined each to weakly sclerotized, small, basal structure, and pair of slender, curved rods overlapping partly trifid sclerites. Apical sclerites formed by subtriangular, central plate joined ventrally to median rod, and to pair of V-shaped rods.

*Comments.* This species may be easily distinguished from *S. lunare* by the shape of the elytral fasciae.

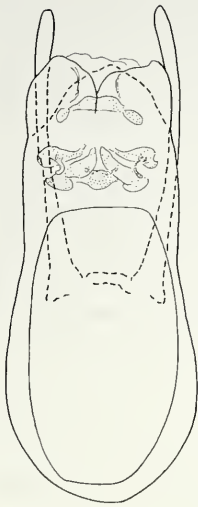

45

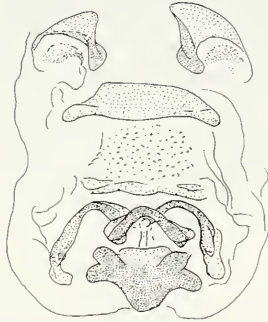

48

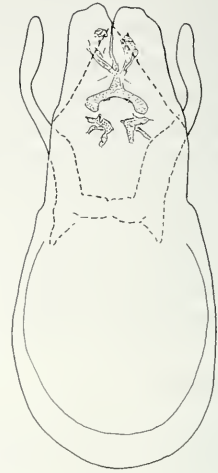

49

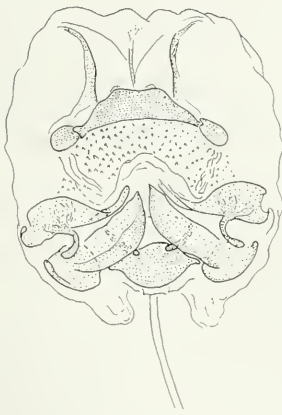

46



47



50

Figs 45-50

Aedeagi in *Scaphidium*; 45 and 46. *S. schuelkei* sp. n.; 47 and 48. *B. kurbatovi* sp. n.; 49 and 50. *S. sichuanum* sp. n. Respective internal sacs (46, 48, 50) in detail. Scale bars = 0.3 mm in figs 45, 47; = 0.2 mm in figs 46, 48, 49; = 0.1 mm in figs. 50.

**Scaphidium kurbatovi** sp. n.

Figs 30, 47, 48

Holotype ♂: China, Central Sichuan, Wolong Nat. Res., 1500m, 22.V.1994, on log with moss, S. A. Kurbatov (MHNG).

Paratypes: same data as holotype, 3 ♂ (MHNG).

*Description.* Length 6 mm. Body, femora and tibiae black, antennae, tarsi and apical abdominal segments very dark brown. Each elytron with narrow, reddish, sub-basal fascia and two small, reddish, subapical spots (Fig. 30). Anterior margin of subbasal fascia semicircular, apical margin bidentate. Frons and vertex finely and sparsely punctate; frons at narrowest point between eyes 0.32 mm. Pronotum not raised above elytra, strongly inflexed anteriorly, with lateral edges moderately sinuate, ante-basal puncture row impressed, not interrupted at middle, discal punctation almost evenly fine and sparse, similar to that on frons, consisting of very shallow punctures; puncture intervals mostly 3 to 5 times as large as puncture diameters. Elytra weakly convex, humeral area not raised, discal impressions absent, disc slightly impressed apically; adsutural area flat and impressed; discal punctation fine and sparse on large inner portion, mostly finer than pronotal punctation, obsolete on lateral area; discal puncture rows absent; sutural stria puncture row relatively fine, basal stria row deeply impressed, with punctures about as coarse as punctures forming pronotal antebasal row. Prohypomera slightly uneven, without microsculpture. Mesepisterna very finely punctate. Exposed abdominal tergites very finely punctate and with microsculpture consisting of punctures. Centre of sternite I with microsculpture consisting of punctures, lateral portions with mesh-like microsculpture. Legs long, mesotibiae and metatibiae curved.

Male sexual characters. Metasternum deeply impressed in middle, with long semi-erect pubescence absent from medio-anterior portion, and two long lateral setal tufts. Profemora with ventral side expanded and forming anterior mid-length flat protuberance, followed by ridge. Protibiae hardly sinuate, gradually wider from base to apical fourth, angulate at widest point, narrowed toward apex. Metafemora slightly expanded in middle portion. Aedeagus (Figs 46, 47) 1.90-2.0 mm long. Median lobe subparallel posterior basal bulb, with tip angular and inflexed. Parameres slightly curved, almost evenly wide. Internal sac having basal complex of sclerites, one transverse subapical sclerotized plate with obliquely prominent basal angles, and two apical inflexed rods. Basal sclerite complex consisting of one plate, one central and two apical, arcuate rods.

*Comments.* This species is similar to *S. nepalense* Löbl from which it differs notably by the shape of the male protibiae and sclerites of the internal sac of the aedeagus. The protibiae are strongly widened and angulate subapically and the subapical sclerite is rhomboid in *S. nepalense*. The new species may be easily distinguished from its congeners by the elytra with punctation obsolete laterally in combination with the presence of two subapical, reddish spots, and the sexual characters as described.

**Scaphidium lunare** sp. n.

Figs 28, 43, 44

Holotype ♂: China, Yunnan, Heishui, 35 km N of Lijiang, 27°13'N, 100°19'E. 1-19.VII. 1991, S. Bečvář (MHNG).

Paratypes: same data as holotype, 5 ♂, 4 ♀; same data but 18.VI.-4.VII.1993, 5 ♂, 6 ♀; Yunnan, Hengduan Mts Yunling, 3300m, 27°14'N, 99°27'E, 17-19.VII.1996, V. Kubán, 1 ♀ (all MHNG).

*Description.* Length 7-8 mm. Body black, antennal segments 1 to 6 and tarsi dark brown. Each elytron with two evenly narrow, strongly arcuate, reddish fasciae (Fig. 28). Subbasal fascia forming large, almost semicircular arc between lateral edge and scutellum. Subapical fascia forming arc between lateral ridge and sutural stria, narrower than smallest interval to apical elytral edge. Frons and vertex finely punctate, almost impunctate on area between posterior eye margins, at narrowest point 0.45-0.50 mm. Pronotum not raised above level of elytra, evenly inflexed anteriorly, with lateral edges oblique or hardly sinuate; antebasal puncture row impressed, not or hardly interrupted at middle, consisting of even, relatively small punctures; discal punctation fine and dense, consisting of well delimited punctures mostly distinctly smaller than puncture intervals. Elytra weakly convex, with adsutural area flat anteriorly, raised posteriorly; sutural stria punctures small, very small near apex, basal stria punctures large. Discal punctation fine and dense, similar to that on pronotal disc. Humeral area not raised; apical impression absent. Prohypomera and metasternum very finely punctate, mesepisterna with punctation slightly less fine. Exposed abdominal tergites, and sternites, evenly finely punctate and with microsculpture consisting of punctures. Lateral impression of sternite I with mesh-like microsculpture. Legs long.

Male sexual characters. Metasternum impressed in middle, not prominent. Metasternal pubescence covering posterior two thirds or entire median portion, recumbent or oblique, dense, short anteriorly, becoming gradually longer posteriorly and forming long, oblique tufts. Profemora expanded anteriorly and forming sharp ridge. Protibiae slightly curved in basal third, with outer edge straight in apical half, inner side becoming stouter toward apical third, narrowed from widest point toward apex; inner edge rounded, not notched and not angulate at widest point. Metafemora slightly thicken. Aedeagus (Figs 43, 44) 2.2-2.3 mm long. Median lobe wide, slightly narrowed apically, with tip obtuse, inflexed. Parameres slender, slightly diverging apically, somewhat narrowed at middle. Internal sac complex, with four basal, one median and two apical sclerites. Basal sclerites consisting of lamellar structure, arcuate sclerite situated more dorsally and pair of rods converging apically. Median sclerite not well delimited. Apical sclerites slender, diverging and abruptly curved apically.

*Comments.* This species may be easily recognized by the shape of the elytral fasciae. It is similar to *S. japonum* Reitter in most external characters, but the inner side of the male protibiae is angulate subapically and the sclerites of the internal sac are very distinct in the latter species.

### **Scaphidium schuelkei** sp. n.

Figs 45, 46

Holotype ♂: China, West Hubei. Shennongjia Nat. Res., 2000-2200m, 3-8.VI.1995, S. Kurbatov (MHNG).

Paratypes: same data as holotype, 1 ♂, 1 ♀ (MHNG); Shaanxi, Qin Ling Shan, 110°06'E, 34°27'N, Hua Shan, 118km east Xian, north Valley, 1200-1400m, 18-20.VIII.1995, D. W. Wraze, 2 ♂ (PCMS, MHNG); Shaanxi, Qin Ling Shan, 107°56'E, 33°45'N, highway km 83 south Zhouzhi, 108 km southwest Xian, 1650m, 1-2.IX.1995, mountain forest, sifted, M. Schülke, 2 ♂, 1 ♀ (PCMS, MHNG), same data but A. Pütz 1 ♂, 1 ♀ (PCAP, MHNG).



*Description.* Length 6-7 mm. Similar to, and sharing most diagnostic characters with *S. becvari*. Body, antennal club, femora and tibiae black, antennal segments 1 to 6 and tarsi ochraceous or dark brown. Elytra with yellowish or ochraceous subhumeral and subapical fasciae. Subhumeral fascia fairly large, delimiting low humeral protuberance, tridentate posteriorly. Subapical fascia much narrower than subhumeral fascia, bidentate anteriorly, evenly rounded posteriorly. Frons at narrowest point between eyes 0.32-0.35 mm. Lateral impressions of sternite I with microsculpture consisting partly of striae.

Male sexual characters. Middle portion of metasternum impressed, pubescence recumbent in middle, becoming longer apically, covering posterior two thirds of median portion, forming two semi-erect lateral tufts. Protibiae strongly widen from basal third to apical fourth, angular at widest point, narrowed toward apex. Profemora expanded and narrowed ventrally to form a ridge. Aedeagus (Figs 45, 46) 1.85 mm long. Median lobe fairly wide, hardly narrowed apically, inflexed and tapering toward tip. Parameres slender, slightly arcuate. Internal sac complex, with seven basal and one apical sclerites. Basal sclerites consisting of one central plate joined to two lateral horizontal plates, two oblique lateral plates and two lateral arcuate rods. Apical sclerite transverse with basal angles obliquely extended and widen at tip.

*Comments.* This species is similar to *S. becvari* from which it may be distinguished by the elytra bearing larger subhumeral fascia and by the shape of the sclerites of the internal sac of the aedeagus.

**Scaphidium stigmatinotum** sp. n.

Fig. 31

Holotype ♀: China, Yunnan, Yizu Mts., 2800m, 25°58'N, 100°21'E, 30.V.-3.VI.1993, Bolm (MHNG).

*Description.* Length 7 mm. Body, antennae and legs black. Elytra each with two well delimited ochraceous fasciae (Fig. 31). Basal fascia large, extended from lateral stria almost to sutural stria, touching basal stria, surrounding small, well delimited, black, round spot, tridentate apically. Apical fascia narrower, bidentate anteriorly, sinuate posteriorly; interval between fascia and sutural stria as large as interval between fascia and apical edge. Frontal punctation well delimited, mostly dense, fine near eye edges, more coarse in middle; vertexal punctation fairly coarse and dense. Frons at narrowest point between eyes 0.40 mm. Pronotum not raised above level of elytra, strongly inflexed anteriorly, with lateral edges slightly sinuate; antebasal puncture row obsolete, not impressed, indicated by several larger punctures anterior basal lobe; discal punctation conspicuously dense and coarse, consisting of punctures mostly much larger than puncture intervals. Elytra fairly convex, without humeral protuberance and without impressions; adsutural area completely flat; discal punctation conspicuous, dense and coarse, less coarse than that on pronotum, puncture diameters about as large as puncture intervals on most surface, mostly smaller than puncture intervals on fasciae; sutural and basal striae punctures about as large as discal punctures. Exposed abdominal tergites dull, with conspicuous mesh-like microsculpture, finely and densely punctate. Prohypomeron uneven, finely punctate. Mesepisterna conspicuously coarsely punctate. Meta

sternum and sternite I finely punctate. Microsculpture consisting of punctures present on sternite I, microsculpture consisting of dense striae on sternites II to IV, and conspicuous mesh-like on sternite V. Legs long, protibiae straight, mesotibiae and metatibiae curved.

*Comments.* This new species resembles *S. shirakii* Miwa & Mitono and *S. klapperichi* Pic from which it may be easily distinguished by the coarsely punctate mesepisterna. In addition, *S. shirakii* possesses a pronotum with a distinct antebasal puncture row and elytra with basal stria punctures much larger than the discal punctures. *Scaphidium klapperichi* differs from both species, *S. stigmatinotum* and *S. shirakii*, by the elytra with subbasal fascia which contours completely two black spots.

**Scaphidium sichuanum** sp. n.

Figs 32, 49, 50

Holotype ♀: China, South Sichuan, south Xichang, Mt. Luoji, 2300-2400m, 16-24.VII. 1996, S. A. Kurbatov (MHNG).

Paratype ♂ same data as holotype (in poor state, head and legs absent) (MHNG).

*Description.* Length 4 mm. Body strongly convex, black or blackish-brown. Pronotal base somewhat reddish. Elytra with ochraceous subbasal spot and subapical transverse fascia (Fig. 32). Subapical spot situated on inflexed lateral side, widen toward and touching lateral edge, longer than wide at lateral edge. Subapical fascia narrow, widen at and touching lateral edge. Tip of abdomen reddish. Antennae with segments 1 to 6 reddish, club black, apical half of segment 11 lighter. Femora very dark reddish to black, tibiae dark reddish-brown, tarsi brown, lighter than tibiae. Head with punctuation very fine and sparse on frons, more distinct and dense on vertex. Frons at narrowest point 0.26 mm. Pronotum raised above level of elytra, strongly inflexed anteriorly; antebasal puncture row impressed, with several large puncture intervals in middle; discal punctuation very fine and fairly dense, similar to that on frons. Elytra convex, moderately narrowed anteriorly, without humeral protuberance and without discal impressions; adsutural area flat; discal punctuation sparse and very fine, as that on pronotum, puncture intervals mostly 5 to 10 times as large as puncture diameters; sutural stria punctures fairly coarse, basal stria punctures much coarser. Prohypomera almost evenly inflexed, with hardly distinct impression in inferior portion, without microsculpture, very finely punctate. Mesepisterna, metasternum and abdominal sternites evenly, very finely punctate. Exposed abdominal segments with microsculpture consisting of punctures; tergites more coarsely punctate than sternites, with mesh-like microsculpture along base, followed by microsculpture consisting of punctures. Legs fairly long, tibiae moderately curved.

Male sexual characters. Middle portion of metasternum uneven, impressed posteriorly. Metacoxal process prominent, truncate, with minute notch in middle. Punctured and pubescent area reaching almost mid-length of metasternum, pubescence recumbent, almost evenly short. Legs in male unknown. Aedeagus (Figs 49, 50) 1.14 mm long. Median lobe hardly inflexed, tapering apically, compression plate large. Parameres inflexed, strongly sinuate, narrowed in middle. Internal sec with inverted Y-shaped central sclerite, pair of diverging apical rods joined to curved sclerotized structure, and pair of complex, narrow basal sclerites. Membranes covered by rounded

and acute scale-like structures, and with two groups of extremely fine spicule-like structures.

*Comments.* This species resembles *S. phungi* Pic by the shape of the body, but is notably more convex. It may be readily distinguished from its congeners by the elytral colour pattern, in combination with the strongly convex body, the pronotum relatively moderately narrowed anteriorly, the pronotum and elytra very finely punctate, and the parameres of the aedeagus strongly sinuate.

### **Pseudobironium Pic**

This genus comprises 25 species currently recognized as valid, most Asian in distribution, except *P. globosum* Löbl from New Caledonia. Two species are known from China, *P. ussuricum* Löbl recorded from «Taipingshein Anhwei» (LÖBL 1984b) and *P. sinicum* Pic described from Kuatun. Two additional species are recorded below.

#### KEY TO THE *PSEUDOBIRONIUM* OF CHINA

- 1 Body reddish-brown or ochraceous, pronotum with dark central spot, elytra darkened along base and apex, and with dark middle fascia or spot ..... *P. bicolor* Löbl
- Body uniformly dark reddish-brown or black ..... 2
- 2 Lateral portions of metasternum coarsely punctate. Antennae relatively stout, segments 7-10 widest at apex ..... *P. ussuricum* Löbl
- Lateral portions of metasternum extremely finely punctate. Antennae slender, segments 7 to 10 widest subapically ..... 3
- 3 Mesocoxal line reaching middle of shortest interval of mesocoxa to metacoxa. Body length about 3 mm ..... *P. sinicum* Pic
- Mesocoxal line reaching to third of shortest interval of mesocoxa to metacoxa. Length 3.3-3.5 mm ..... *P. cf. castaneum* Pic

### **Pseudobironium sinicum Pic**

Type material examined. Lectotype ♀, labelled: Kuatun, Fukien China 2.10.46 (Tchung Sen) / 9843 E 91/*Pseudobironium sinicum* det. Pic, n. sp. [red, handwritten]/Lectotype *Pseudobironium sinicum* Pic det. Löbl, 1998 (NHRM); paralectotype ♀ with the same locality label but from 2.10.46/*Pseudobironium sinicum* nsp. [handwritten by Pic] (MHNG) - by present designation.

Additional material. China, Fujien, Kuatun, 23.3.46 Tschung Sen, 1 ♀ (MHNG).

*Distribution.* China: Fujien.

### **Pseudobironium bicolor Löbl**

Material examined. China, South Yunnan, Mengyang Nat. Res., cca 500m, 12.IX.1994, S. A. Kurbatov, 1 ♂ (MHNG).

*Distribution.* Nepal; North East India; Thailand; China: Yunnan.

*Comments.* This species may be readily distinguished by the colour pattern, as illustrated in LÖBL 1992.

**Pseudobironium cf. castaneum** Pic

Material examined. Yunnan, Rutli, 4.II.1993, G. de Rougemont, 3 ♀ (MHNG).

*Distribution.* Nepal; Vietnam; ?China: Yunnan.

*Comments.* The specimens from China are females. They are identified tentatively as *P. castaneum* Pic because only male genitalia provide sure diagnostic characters.

**Baeocera** Erichson

Although this genus is with almost 220 described species one of the largest of the subfamily, in terms of species diversity, only six species, including two unidentified ones (LÖBL 1984b, ROUGEMONT 1996), were recorded from China. Within the collections examined 20 species were recognized, five of which are new.

While members of the taxa treated above were usually found on fungi growth, all *Baeocera* come from sifted forest floor litter.

## KEY TO THE BAEOCERA OF CHINA

- |   |   |                               |
|---|---|-------------------------------|
| 1 | Lateral portions of metasternum impunctate or very finely and sparsely punctate . . . . .   | 2                             |
| - | Lateral portions of metasternum coarsely and usually densely punctate, or at least with a few coarse punctures . . . . .  | 14                            |
| 2 | Elytra with basal stria interrupted at level of humeral protuberance, not joined to lateral stria. Exposed portion of scutellum large . . . . .                         | 3                             |
| - | Elytra with basal stria joined to lateral stria. Scutellum usually concealed or with minute exposed tip, or exceptionally large (in <i>B. breveapicalis</i> ) . . . . . | 6                             |
| 3 | Apical portion of median lobe of aedeagus large, not overlapped by basal bulb, about as long as latter. Male metatibia with subbasal denticle . . . . .                 | <i>B. satana</i> Nakane       |
| - | Apical portion of median lobe of aedeagus small, much shorter than basal bulb, partly or entirely overlapped by latter. Metatibia without subbasal denticle . . . . .   | 4                             |
| 4 | Parameres of aedeagus simple, curved and hook-like at apex . . . . .  | <i>B. gilloghyi</i> (Löbl)    |
| - | Parameres of aedeagus lobed, not hook-like at apex . . . . .  | 5                             |
| 5 | Left paramere with small dorsal lobe and apex inflexed ventrally; right paramere lobed ventrally . . . . .  | <i>B. yunnanensis</i> sp. n.  |
| - | Left paramere with large dorsal lobe and apex barely inflexed; right paramere not lobed . . . . .   | <i>B. pubiventris</i> Löbl    |
| 6 | Antennal segment 6 short and wide, about as long as half of segment 7 and 2 times as long as wide . . . . .   | <i>B. breveapicalis</i> (Pic) |
| - | Antennal segment 6 elongate and narrow, slightly shorter than segment 7 and 3-5 times as long as wide . . . . .   | 7                             |
| 7 | Parameres of aedeagus expanded dorso-apically to form very large, strongly sclerotized lobe . . . . .   | <i>B. kubani</i> sp. n.       |
| - | Parameres of aedeagus without lobe or with small, slightly sclerotized, subapical lobe . . . . .  | 8                             |

- 8 Apical portion of parameres strongly widen . . . . . *B. huashana* sp. n.  
 - Apical portion of parameres not or hardly widen . . . . . 9
- 9 Antennal segment 11 about twice as long as wide. Lateral contours of pronotum and elytra continuously arcuate in dorsal view. Elytral punctation mostly obsolete . . . . . *B. xilingana* sp. n.  
 - Antennal segment 11 about 3 times as long as wide. Lateral contours of pronotum and elytra separately arcuate in dorsal view. Elytral punctation usually fine but distinct . . . . . 10
- 10 Internal sac of aedeagus without strongly sclerotized guide-sclerite . . . . . *B. xichangana* sp. n.  
 - Internal sac of aedeagus with strongly sclerotized guide-sclerite . . . . . 11
- 11 Guide-sclerite of internal sac narrow, angulate basally . . . . . *B. callida* Löbl  
 - Guide-sclerite of internal sac robust, not angulate basally . . . . . 12
- 12 Guide-sclerite of internal sac gradually tapering apically . . . . . *B. freyi* Löbl  
 - Guide-sclerite of internal sac not tapering apically . . . . . 13
- 13 Guide-sclerite of internal sac straight, stouter apically . . . . . *B. cooteri* sp. n.  
 - Guide-sclerite of internal sac abruptly curved in middle, widen subapically, pointed at tip . . . . . *B. hammondi* Löbl
- 14 Metatarsi short, as long as or slightly longer than half of metatibiae. Elytra with sutural stria not extendend along basal edge. Body length 1.7-2.3 mm. . . . . *B. mussardi* Löbl  
 - Metatarsi long, as long as or longer than 4/5 of metatibiae. Elytra with sutural stria extended along basal edge. Body length 1.2 - 1.5 mm . . . . . 15
- 15 Elytra each with basal stria not joined to lateral stria. Parameres of aedeagus notched . . . . . *B. franzi* (Löbl)  
 - Elytra each with basal stria joined to lateral stria. Parameres of aedeagus not notched . . . . . 16
- 16 Elytral punctation obsolete . . . . . *B. sordidoides* Löbl  
 - Elytral punctation distinct . . . . . 17
- 17 Punctuation distinct only on basal half of elytral disc . . . . . *B. pseudinculta* Löbl  
 - Punctuation distinct on most of elytral disc . . . . . 18
- 18 Metepisternum distinctly separated from metasternum by deep suture. Antennal segment 3 short, about as long as 2/3 of segment 4 . . . . . *B. serendibensis* (Löbl)  
 - Metepisternum indistinctly separated from metasternum by outer puncture row. Antennal segments 3 and 4 almost equally long . . . . . 19
- 19 Aedeagus with parameres straight, conspicuously narrow . . . . . *B. vidua* Löbl  
 - Aedeagus with parameres slightly sinuate or arcuate, not particularly narrow . . . . . 20
- 20 Aedeagus with parameres diverging apically; internal sac without row of denticles . . . . . *B. longicornis* (Löbl)  
 - Aedeagus with parameres converging at apex; internal sac with one or two row of denticles situated posterior sclerite complex . . . . . *B. pigra* (Löbl)

**Baeocera serendibensis** (Löbl)

Material examined. China, Hong Kong, V. 1996, G. de Rougemont, 2 (MHNG).

*Distribution.* India; Nepal; Sri Lanka; Thailand; China: Hong Kong.

**Baeocera sordidoides** Löbl

Material examined. China, Sichuan, Xiling Mts, 1600-2400m, litter, 30.VII.-4.VIII.1996, S. A. Kurbatov, 1 (MHNG).

*Distribution.* Nepal; China: Sichuan.

*Comments.* This specimen is tentatively assigned to *B. sordidoides*. It differs conspicuously from the type series by the metasternal punctation which is highly reduced, fine and sparse.

**Baeocera mussardi roberti** Löbl

Material examined. China, Hong Kong, III, V, and IX. 1996, G. de Rougemont, 19 (MHNG); Zhejiang, Lin'an County, ca 200m, W Tienmu Shan Nat. Res., 22.V.1996, J. Cooter, 1 (MHNG); Yunnan, Gaoligong Mts, 1500-2500m, 25°22'N 98°49'E, 1.-24.V.1995, O. Semela, 1 (NHMB); Yunnan, Shi Lin, 8.X.1985, G. de Rougemont, 1 (MHNG).

*Distribution.* Bhutan; India; Nepal; China: Hong Kong, Zhejiang, Yunnan.

**Baeocera longicornis** (Löbl)

Material examined. China, Hong Kong, III. 1996, G. de Rougemont, 2 (MHNG); South Yunnan, Mengyang Nat. Res., ca 500m, 11. and 14.IX.1994, S. A. Kurbatov, 2 (MHNG).

*Distribution.* India; Nepal; Sri Lanka; Thailand; China: Hong Kong, Yunnan.

**Baeocera pigra** (Löbl)

Material examined. China, South Yunnan, Mengyang Nat. Res., ca 500m, 9. and 11.IX. 1994, S. A. Kurbatov, 2 (MHNG).

*Distribution.* India; Nepal; Sri Lanka; Thailand; China: Yunnan.

**Baeocera vidua** Löbl

Material examined. China, East Hubei, near Macheng, ca 500m, 25.V.1995, S. Kurbatov, 1 (MHNG); northeast Guangxi, 10km S Longsheng, ca 1000m, 15.VI.1995, S. A. Kurbatov, 6 (MHNG); Sichuan, Mt. Emei, 1500m, 21.IX.1994, S. A. Kurbatov, 3 (MHNG); Yunnan, Gaoligong Mts, 1500-2500m, 25°22'N 98°49'E, 17.-24.V.1995, O. Semela, 2 (NHMB).

*Distribution.* Thailand; China: Hubei, Guangxi, Sichuan, Yunnan.

**Baeocera pseudinculta** Löbl

Material examined. China, South Yunnan, Mengyang Nat. Res., ca 500m, 10.IX.1994, S. A. Kurbatov, 1 (MHNG).

*Distribution.* Thailand; China: Yunnan.

*Comments.* The parameres of the aedeagi are narrower in the Chinese specimens than those in the specimens from Thailand.

**Baeocera franzi** (Löbl)

Material examined. China, South Yunnan, Mengyang Nat. Res., ca 500m, 9-14.IX.1994, S. A. Kurbatov, 55 (MHNG); Yunnan, Yipinglang, 1800-2000m, 17-20.VI.1994, V. Kubán, 1 (NHMB); Sichuan, Mt. Emei, 1700 and 1800m, 22. and 24.IX.1994, S. A. Kurbatov, 2 (MHNG); Sichuan, Qingshen Shan, 65km NW Chengdu, 8km W Taiping, 103°33'E 30°53'N, 18.V.-4.VI.1997, 800-1000m, A. Pütz, 3 (PCAP); Sichuan, east Xian, Mt. Huashan, 9-11.V.1994, S. A. Kurbatov, 2 (MHNG); South Sichuan, near Xichang, 1600m, 28.VII.1996, S. A. Kurbatov (MHNG); East Hubei, near Macheng, ca 500m, 25.V.1995, S. A. Kurbatov, 5 (MHNG); Hubei, Wuhan, park, 200m, 28.V.1995, S. A. Kurbatov, 4 (MHNG); Jiangsu, Nanjing, Zijinshan, 8.V.1996, J. Cooter, 3 (MHNG); Shaanxi, Qin Lin Shan, 110°06'E, 34°27'N, Hua Shan, north valley, 1200-1400m, 118km east Xian 18-20.VIII.1995, M. Schülke, 1 (PCMS).

*Distribution.* Thailand; China: Yunnan, Sichuan, Hubei, Jiangsu, Shaanxi.

**Baeocera callida** Löbl

Material examined. China, South Yunnan, Mengyang Nat. Res., ca 500m, 14.IX.1994, S. A. Kurbatov, 1 (MHNG); Yunnan, Xishan, 2300m, 24°57'N, 102°38'E, 27.VII.1983, Bolm, 3 and V. Kubán, 1 (NHMB).

*Distribution.* Pakistan; North India; Nepal; China: Yunnan.

**Baeocera freyi** Löbl

Material examined. China, Shaanxi, Qin Lin Shan, 108°49'E, 33°55'N, River Valley 40 km south Xian, autoroute km 50, River bank, 1200m, 31.VIII.1995, M. Schülke, 1 and A. Pütz, 6; Jiangsu, Nanjing Zijinshan, 8.V.1996, J. Cooter, 1 (MHNG, PCAP).

*Distribution.* Far East Russia; North Korea; China: Shaanxi.

*Comments.* This species may be easily distinguished from its congeners by the shape of the sclerites of the internal sac (Figs 58, 59).

**Baeocera hammondi** Löbl

Material examined. China, Shaanxi, East Xian, Mt. Huashan, 1700m, 9-11.V.1994, litter, S. A. Kurbatov, 1 (MHNG).

*Distribution.* China: Shaanxi.

**Baeocera gilloghyi** (Löbl)

Material examined. China, South Yunnan, Mengyang Nat. Res. ca 500m, 9 and 11.IX.1994, S. A. Kurbatov, 5 (MHNG).

*Distribution.* Northeast India; Vietnam; China: Yunnan.

*Comments.* This species is unique in having the apical portion of the left paramere strongly widen to form a large dorsal lobe.

**Baeocera pubiventris** Löbl

Material examined. China, South Yunnan, Mengyang Nat. Res. ca 500m, 9 and 11.IX.1994, S. A. Kurbatov, 4 (MHNG).

*Distribution.* North India; Nepal; Thailand; China: Yunnan.

*Comments.* This species may be easily distinguished from its congeners by the shape of the parameres, as figured in LÖBL (1990b).

**Baocera brevecapicalis** Pic

Material examined. China, Northeast Guangxi, 10 km S Longsheng, ca 1000m, 15.VI.1995, S. A. Kurbatov, 2 (MHNG); S. Yunnan, Mengyang Nat. Park, ca 500m, 12.IX.1994, S. A. Kurbatov, 3 (MHNG).

*Distribution.* Vietnam; China: Guangxi, Yunnan.

*Comments.* This species may be distinguished from the members of the *B. monstrosa* group by the aedeagal characters only (Fig. 63).

**Baocera satana** Nakane

Material examined. China, Northeast Guangxi, 10km south Longsheng, ca 1000m, litter, 15.VI.1995, S. A. Kurbatov, 1 (MHNG).

*Distribution.* Japan; China: Guangxi.

*Comments.* This species is member of a small group of species (*B. dentipes* Löbl, *B. errabunda* Löbl, *B. monstroseitibialis* Löbl, *B. thoracica* Löbl and *B. tuberculata* Löbl) which have modified metatibiae in males. All but *B. satana* are known from India and Nepal. *Baocera satana* may be easily distinguished from its Chinese congeners by the shape of the aedeagus (see LÖBL 1994a) and male metatibiae.

**Baocera xichangana** sp. n.

Figs 51, 52

Holotype ♂: China, South Sichuan, near Xichang, 1600m, 28.VII.1996, S. A. Kurbatov (MHNG).

Paratypes: same data as holotype, 2 ♂, 2 ♀ (MHNG).

*Description.* Length 2.0 - 2.15 mm. Body reddish-brown to blackish. Apex of abdomen, antennae and tarsi lighter. Relative length of antennal segments 3 to 11 as: 15: 18: 20: 19: 20: 15: 19: 17: 23 (holotype); segments 3 to 6 evenly slender; segments 7 and 8 evenly wide, slightly wider than segment 6; segment 7 about 5 times as long as wide; segment 8 about 4 times as long as wide; club segments much wider than segment 8; segment 11 about 3 times as long as wide and twice as wide as segment 8. Lateral contours of pronotum and elytra separately arcuate in dorsal view. Lateral pronotal keel sinuate posteriorly (lateral view). Pronotum and elytra lacking microsculpture, very finely punctate. Punctuation on basal portion of elytra as that on pronotal disc, punctuation on posterior half of elytra slightly more distinct. Scutellum completely covered by pronotal lobe. Elytra with entire basal stria joined to lateral stria, and middle portion of lateral edge straight in dorsal view. Prohypomera and mesepisterna impunctate. Lateral portions of metasternum extremely finely punctate. Mesocoxal lines parallel to coxa, bordered by fairly small, not elongate pits. Metepisternum flat, wide, slightly narrowed anteriorly or parallel-sided, with deep, straight, impunctate suture. Exposed abdominal sternites very finely punctate, without microsculpture. Protibiae straight, mesotibiae and metatibiae barely curved.

## FIGS 51-55

Aedeagi in *Baocera*: 51 and 52. *B. xichangana* sp. n.: 53. *B. huachana* sp. n.: 54 and 55. *B. cooteri* sp. n. Scale bars = 0.2 mm.



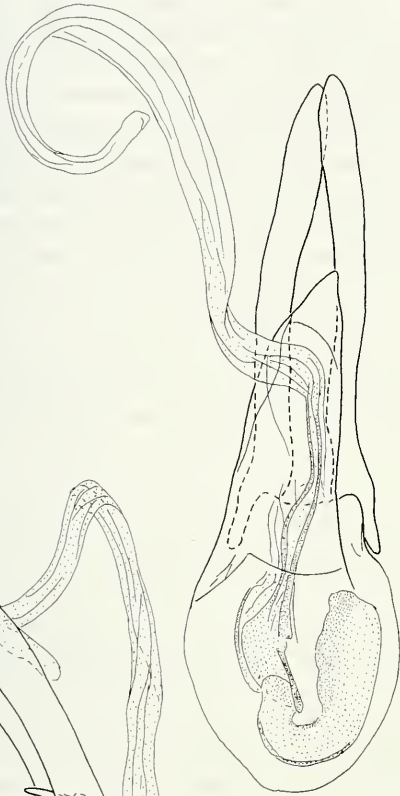

51

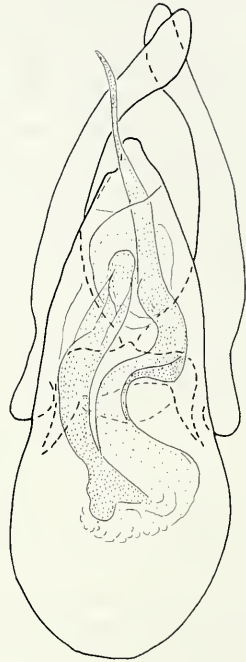

53

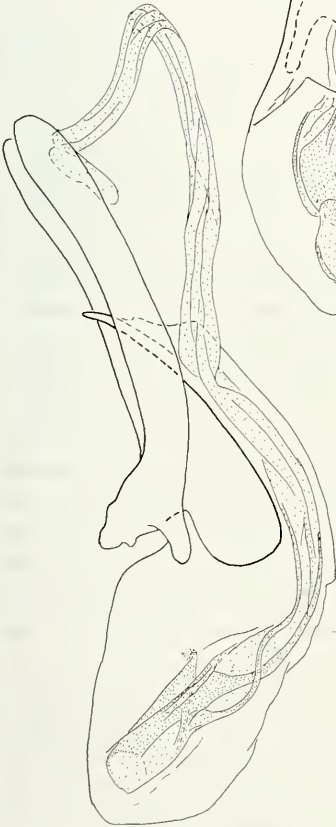

52



54

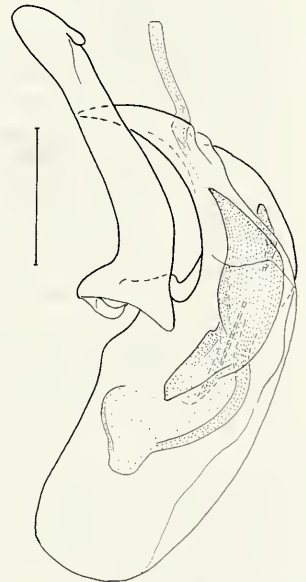

55

Male sexual characters. Segments 1 and 2 of protarsi strongly widen, slightly narrower than protibia; segment 3 of protarsi distinctly widen. Aedeagus (Figs 51, 52) 0.97-0.98 mm long. Median lobe slightly asymmetrical, with basal bulb moderately sclerotized, about as long as apical portion. Apical portion gradually narrowed in dorsal view, inflexed, arcuate, and almost evenly wide (tip excepted) in lateral view. Orifice of dorsal valve long, situated along right edge. Parameres conspicuously long, symmetrical, with inner and outer edge sinuate, almost evenly wide between expanded basis and apex. Internal sac with U-shaped basal sclerite, extended by long flagellum sclerotized along edges. Long apical portion of flagellum weakly sclerotized, extruded. Flagellar guide-sclerite absent.

*Comments.* *Baeocera xichangana* is unique by its aedeagal characters and cannot be placed in any known species group (LÖBL 1992, LÖBL & STEPHAN 1993). It may be easily distinguished from its congeners by the dorsal valve of the median lobe open along the right edge, the long parameres and the internal sac with very long flagellum sclerotized along both edges.

***Baeocera huashana* sp. n.**

Fig. 53

Holotype ♂: China, East Xian, Mt. Huashan, 1700m, 9-11.V.1994, S. A. Kurbatov (MHNG).

*Description.* Length 2.10 mm. Body black, apices of elytra and abdomen dark brown. Legs brown, tarsi lighter than tibiae and femora. Antennae light brown. Relative length of antennal segments 3 to 11 as: 16: 18: 20: 18: 20: 17: 19: 17: 23. Segments 3 to 6 almost evenly wide; segments 7 and 8 evenly wide, slightly wider than 6, segment 7 about 5 times as long as wide, segment 8 about 4 times as long as wide; club segments much wider than segments 7 or 8, segment 11 about 2.5 times as long as wide and 2 times as wide as segment 7. Lateral contours of pronotum and elytra separately arcuate in dorsal view. Pronotum and elytra without microsculpture. Pronotal punctation very fine. Scutellum completely covered by pronotal lobe. Elytra with basal stria entire, joined to lateral stria; lateral edge straight in middle portion (dorsal view). Elytral punctation fine, punctures notably larger than those on pronotal disc. Prohypomera, mesepisterna and lateral portions of metasternum extremely finely punctate. Mesocoxal lines convexly arcuate, bordered by coarse, slightly elongate pits. Metepisternum wide, flat, slightly widen posteriorly, with almost straight, impunctate suture. Sternite I with coarse, partly elongate basal pits, extremely finely punctate, not microsculptured. Following sternites with microsculpture consisting of punctures. Protibiae and mesotibiae straight, metatibiae slightly curved.

Male sexual characters. Segments 1 of protarsi and mesotarsi strongly widen, narrower than tibiae. Segment 2 of protarsi strongly widen, narrower than segment 1. Segment 3 of protarsi and segment 2 of mesotarsi slightly widen. Aedeagus (Figs 53) 0.95 mm long. Basal bulb fairly strongly sclerotized. Apical portion of median lobe slightly asymmetrical, shorter than basal bulb, gradually narrowed in dorsal view, with tip blunt, strongly inflexed ventrally. Ventral process large, prominent, with tubercle in middle. Parameres arcuate, with long basal process, gradually narrowed toward apical

portion, apex widen. Internal sac with wide, bisinuate, strongly sclerotized flagellum, extended by narrow, weakly sclerotized, extruded portion. Flagellar guide-sclerite long, slender, widen at base and at apex.

*Comments.* This species is a member of the *B. curtula* group (LÖBL 1992). It may be distinguished from most members of that group (*B. kapfereri* Reitter, *B. freyi* Löbl, *B. hammondi* Löbl, *B. hamifer* Löbl, *B. mustangensis* Löbl, and *B. cooteri* and *B. kubani* described below) by the shape of the parameres. It resembles *B. curtula* Achard by the shape of the apically widen parameres, although they are narrower in the latter species. It differs conspicuously from *B. curtula* by the elytral punctuation, which is in *B. curtula* as fine as the pronotal punctuation, by the larger aedeagus with bisinuate flagellum of the internal sac, and by the tuberculate basal process of the median lobe.

**Baeocera cooteri** sp. n.

Figs 54, 55

Holotype ♂: China, Zhejiang, Lin'an county, ca 500m, W Tianmu Shan N. R., 16.V.1996, J. Cooter (MHNG).

Paratypes: same data as holotype, 3 ♂, 2 ♀; same data but 300m, 22.V., 1 ♂; same data but 350, 16-22.V., 1 ♀; Zhejiang, Lin'an County, Lin Long Shan, 250m, 22.V.1996, J. Cooter, 5 ♂, 1 ♀; Hong Kong, III.1996, R. de Rougemont, 1 ♂ (all MHNG).

*Description.* Length 1.80-2.15 mm. Body dark brown to black, apical abdominal segments and appendages lighter. Most external characters as in *B. huashana* but pits bordering mesocoxal lines and base of sternite I distinctly elongate. Relative length of antennal segments 3 to 11 as: 15: 20: 20: 19: 20: 16: 19: 17: 25 (holotype). Elytra with distinct discal punctuation.

Male sexual characters. Segments 1 to 3 of protarsi strongly widen, segment 1 almost as wide as protibiae, following segments gradually narrowed. Mesotarsi with segment 1 strongly widen, segments 2 and 3 slightly widen. Aedeagus (Figs 54, 55) 0.80-0.90 mm long. Basal bulb fairly sclerotized. Apical portion of median lobe shorter than basal bulb, slightly asymmetrical and with apex blunt in dorsal view, inflexed, almost evenly concave and narrowed toward tip in lateral view. Ventral process moderately projecting. Parameres with long basal process, sinuate and almost evenly wide in dorsal view, moderately curved in lateral view, with small, dorso-apical lobe. Internal sac with flagellum joined to incurved rods; flagellar guide-sclerite almost straight, narrow, except strongly expanded apical portion in dorsal view, robust and hook-like in lateral view.

*Comments.* This species is characterised by the shape of the flagellar-guide sclerite and parameres. It may be readily distinguished from other members of the *B. curtula* group known from China (*B. callida*, *B. hammondi*, *B. freyi*, *B. huashana*, *B. kubani*) by the distinct elytral punctuation.

**Baeocera kubani** sp. n.

Figs 56, 57

Holotype ♂: China, Yunnan, Jizu Mts, 2800m, 26°58'N 100°21'E, 30.V.-3.VI.1993, S. Kubán (MHNG).

*Description.* Length 2.47 mm. Body black, apical abdominal segments and tibiae dark brown, tarsi and antennae ochraceous. Antennae apparently long (segments

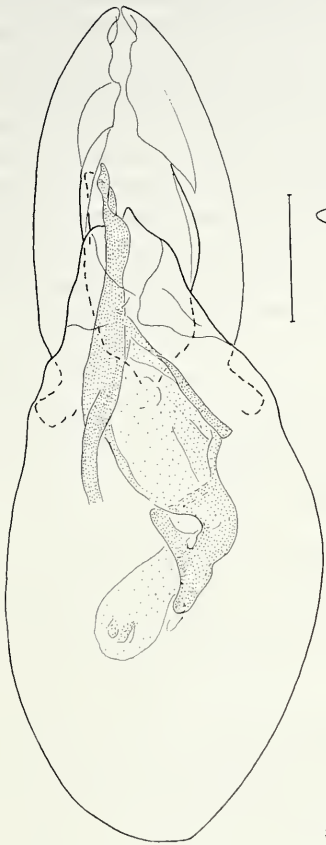

56



57

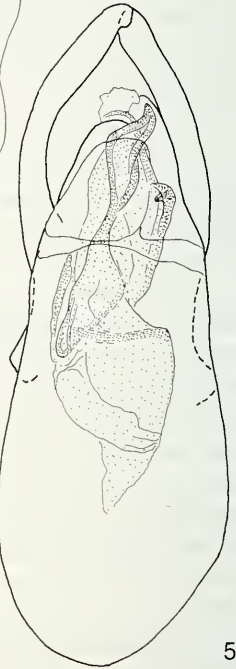

58

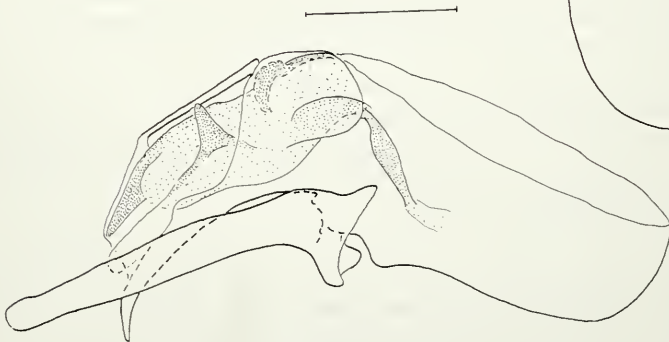

59

8 to 11 of both antennae broken off and lost). Relative length of segments 3 to 7 as: 21: 19: 20: 20: 20. Segments 3 to 6 almost equally wide, segment 7 wider than 6, about 5 times as long as wide. Lateral contours of pronotum and elytra separately arcuate in dorsal view. Pronotum and elytra without microsculpture. Pronotal punctation dense, extremely fine. Scutellum completely covered by pronotal lobe. Lateral edges of elytra slightly rounded in dorsal view, basal stria entire. Elytral punctation dense, consisting of punctures extremely shallow, mostly about as small as pronotal punctures, some punctures distinctly larger. Prohypomera, mesepisterna and lateral portion of metasternum extremely finely punctate. Mesocoxal lines parallel to coxa, bordered by coarse, not elongate marginal pits. Metepisterna large, almost flat, with suture deep, impunctate, almost straight. Exposed abdominal tergites very finely punctate. Sternites I to V without microsculpture, very finely punctate; basal pits of sternite I not elongate. Protibiae and mesotibiae hardly curved, metatibiae straight.

Male sexual characters. Segments 1 to 3 of protarsi strongly widen, narrower than protibiae; segment 2 slightly narrower than segment 1, segment 3 distinctly narrower than segment 2. Segment 1 of mesotarsi strongly widen, segments 2 and 3 moderately widen. Median portion of exposed abdominal sternites bearing very sparse pubescence. Aedeagus (Figs 55, 56) 1.27 mm long. Median lobe with moderately sclerotized basal bulb. Apical portion of median lobe gradually narrowed in dorsal view, strongly inflexed, slightly asymmetrical, shorter than basal bulb. Ventral process small, not prominent. Parameres with short basal processes, almost evenly narrow between widen basis and mid-length, strongly expanded dorsally between mid-length and apex, forming conspicuous, large, relatively strongly sclerotized lobe. Internal sac with complex sclerotized basal structures. Flagellar guide-sclerite robust, partly extruded, flattened vertically, raised subapically, with apical hook.

*Comments.* This species may be easily distinguished from its congeners by the shape of the parameres expanded by a dorsal lobe conspicuously large, and by the shape of the flagellar guide-sclerite. See comments under *B. cooteri*.

### ***Baeocera yunnanensis* sp. n.**

Figs 60-62

Holotype ♂: China, South Yunnan, Mengyang Nat. Res., ca 500m, 9.IX.1994 S. A. Kurbatov (MHNG).

Paratypes: same data as holotype, 2 ♂, and same data but from 11.IX., 1 ♂ (MHNG).

*Description.* Length 1.7 - 1.8 mm. Body, femora and tibiae uniformly ochraceous, or prothorax and abdomen lighter than elytra and metasternum. Antennae and tarsi lighter than prothorax and abdomen. Antennae long, relative length of segments 3 to 11 as: 12: 16: 18: 15: 20: 18: 22: 20: 30 (holotype). Segments 3 to 6 equally narrow, segment 5 about 4 times as long as wide; segments 7 and 8 equally wide, slightly wider than segment 6, segment 7 about 4 times as long as wide; segments 9 and 10 each

Figs 56-59

Aedeagi in *Baeocera*: 56 and 57. *B. kubani* sp. n.; 58 and 59. *B. freyi* Löbl. Scale bars = 0.2 mm.

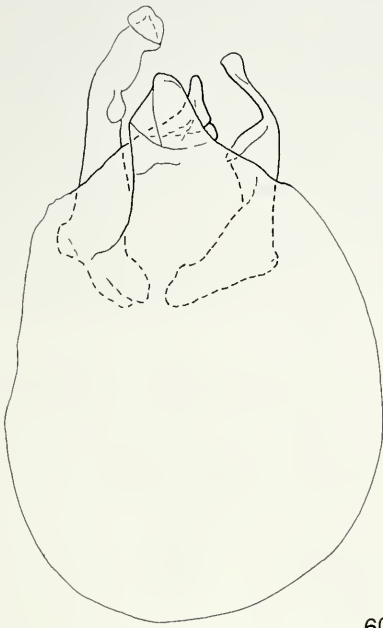

60



61



62

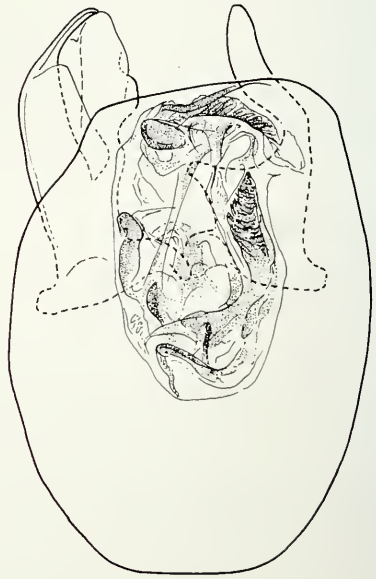

63

slightly wider than 8; segment 11 as wide as or wider than 10, about 4 times as long as wide. Lateral contours of pronotum and elytra separately arcuate. Pronotum and elytra lacking microsculpture. Pronotum with extremely fine punctation. Exposed portion of scutellum large. Lateral edge of elytra almost straight in middle third. Elytra with basal stria interrupted at humeral area. Humeral area slightly raised. Elytral punctation fairly fine, consisting of well delimited punctures, intervals mostly 2 to 5 times as large as puncture diameters; basal portion of elytra extremely finely punctate. Prohypomera and mesepisterna impunctate. Lateral portions of metasternum extremely finely punctate. Mesocoxal lines parallel, with marginal pits extended laterally, not or slightly elongate. Metepisternum large, flat, narrowed anteriorly, with impressed, slightly rounded suture. Abdominal tergites with microsculpture consisting of punctures; punctation fairly fine, about as that of apical portion of elytra, but more dense. Abdominal sternites with extremely fine punctation, lacking microsculpture; basal pits of sternite I not or hardly elongate. Tibiae slightly curved.

Male sexual characters. Protarsi and mesotarsi with segments 1 strongly widen, about as wide as tibiae; segments 2 slightly widen, segments 3 hardly widen. Aedeagus (Figs 60-62) 0.83-0.87 mm long. Basal bulb large, weakly sclerotized. Apical portion of median lobe not inflexed, short, asymmetrical, with tip blunt in dorsal view, pointed in lateral view. Ventral process small, not prominent. Parameres strongly asymmetrical, relatively narrow. Left paramere moderately narrowed apically, with large mediodorsal lobe, and abruptly inflexed apex. Right paramere abruptly narrowed in posterior third, and with ventral lobe. Internal sac very complex.

*Comments.* This new species is a member of the *B. monstrosa* group. Is it very similar to *B. pubiventris* and *B. gylloghysi* with which it was found. It may be easily distinguished from these two species by the right paramere abruptly narrowed and lobed ventrally, and the left paramere lobed dorsally.

### **Bironium** Csiki

The genus comprises 27 species, all known from subtropical or tropical areas of Asia and in New Guinea. Members of *Bironium* were not yet reported from China. One species is present within the collections examined.

### **Bironium bidens** Löbl

Material examined. China, South Yunnan, Mengyang Nat. Res., ca 500m, 9-14.IX.1994, S. A. Kurbatov, 14 (MHNG).

*Distribution.* Thailand; China: Yunnan.

### **Mysthrix** Champion

This genus comprises two likely termitophilous species, one of which occurs also in China. The second species, *M. kistneri* Löbl, is known from Sumatra.

---

#### Figs 60-63

Aedeagi in *Baocera*; 60 to 62. *B. yunnanensis* sp. n., internal sac (62) in detail; 63. *B. brevipicalis* (Pic). Scale bars = 0.2 mm in figs 60, 61; = 0.1 mm in figs 62, 63.

**Mysthrix termitophilum** Champion

Material examined. China, Hong Kong, III, V, and X-XII.1996, G. de Rougemont, 31 (MHNG).

*Distribution.* North India; Nepal; China; Hong Kong.

*Comments.* The specimens from China are slightly larger than the few ones which I have seen from the Himalayan region.

**Scaphicoma** Motschulsky

This genus comprises eleven species currently recognized as valid, distributed in South East Asia, New Ireland, and tropical Africa. Although some species of *Scaphicoma* may be readily recognized (e.g., *S. nigrovittata* (Achard), *S. flavovittata* Motschulsky) by the colour pattern and punctuation, reliable diagnostic characters are unknown from most of them. For this reason I could not identify one of the two species found in China.

**Scaphicoma arcuata** (Champion, 1927)

Material examined. China, South Yunnan, Mengyang Nat. Res., ca 500m, 11.IX.1994, S. A. Kurbatov, 1 (MHNG).

*Distribution.* North India; Nepal; Thailand; China: Yunnan.

*Comments.* This species differs from the similar *S. apicalis* (Pic) by the abdominal sternite I with dense basolateral punctuation.

**Scaphicoma** sp.

Material examined. China, Northeast Guangxi, 10km S Longsheng, ca 1000m, 15.VI.1995, S. A. Kurbatov, 2 ♀ (MHNG).

*Comments.* These specimens represent possibly a separate species. They differ from *S. apicalis* and *S. arcuata*, and resemble *S. cincta* (Pic) by their colour pattern. The body is ochraceous but the bases of the pronotum and elytra, the elytral apices and lateral edges, large portions of the prohypomera, mesepisterna, metasternum, and the entire metepisterna are strongly darkened.

**Scaphobaeocera** Csiki

This genus is widely distributed and found in Asia, New Guinea, Australia, Micronesia, Mascarene archipelago and tropical Africa. It comprises 60 described species. Seven are known to occur in Japan (LÖBL 1981), one from Far Eastern Russia (LÖBL 1993), and one unidentified species was recorded from China (ROUGEMONT 1996). The new material raises the number of Chinese species to eleven, three of which are new.



KEY TO THE *SCAPHOBÆOCERA* OF CHINA

- 1 Antennal segment 11 shorter than, or as long as, segment 10 . . . *S. spinigera* Löbl  
 - Antennal segment 11 longer than segment 10 . . . . . 2
- 2 Antennal segment 11 about as long as segments 9 and 10 combined.  
 Body length 1.1-1.3 mm . . . . . *S. dorsalis* Löbl  
 - Antennal segment 11 shorter than segments 9 and 10 combined . . . . . 3
- 3 Prohypomera with longitudinal stria. Antennal segment 8 about 4 times  
 as long as wide. Body length 1.6 mm . . . . . *S. pseudovalida* sp. n.  
 - Prohypomera without stria. Antennal segment 8 about as long as wide, or  
 upto 2 times as long as wide. Body length 1.1-1.5 mm . . . . . 4
- 4 Aedeagus with parameres notched subapically . . . . . *S. incisa* Löbl  
 - Aedeagus with parameres not notched . . . . . 5
- 5 Aedeagus with median lobe forming ventral plate prominent posterior  
 articular process . . . . . *S. lamellifera* Löbl  
 - Aedeagus with median lobe lacking ventral plate . . . . . 6
- 6 Aedeagus with flagellum simple, evenly, slightly arcuate, narrowed gra-  
 dually apically . . . . . *S. simplex* sp. n.  
 - Aedeagus with flagellum different . . . . . 7
- 7 Aedeagus with flagellum spiral and simple . . . . . 8  
 - Aedeagus with flagellum not spiral, or spiral and complex basally . . . . . 9
- 8 Aedeagus with flagellum forming two or three complete circles . . . . . *S. difficilis* Löbl  
 - Aedeagus with flagellum forming six or seven complete circles . . . . . *S. spira* Löbl
- 9 Aedeagus with basal bulb prominent apicoventrally . . . . . *S. nobilis* Löbl  
 - Aedeagus with basal bulb not prominent apicoventrally . . . . . 10
- 10 Apical third of parameres conspicuously widen in lateral view; flagellum  
 spiral, with base large and complex . . . . . *S. molesta* sp. n.  
 - Apical two thirds of parameres moderate widen in lateral view; flagellum  
 irregularly incurved, not spiral, with base fairly small, hook-like  
 . . . . . *S. cognata* Löbl

***Scaphobæocera lamellifera* Löbl**

Material examined. China, Yunnan, Gaoligong Mts, 25°22'N 98°49'E, 1500-2500m, 17-24.V.1995, O. Semela, 1 (MHNG).

*Distribution.* Northeast India; China: Yunnan.

*Comments.* This species was known from two males taken in the Garo Hills, Meghalaya. The single specimen from Yunnan exhibits exactly the same conspicuous aedeagal characters as the types.

***Scaphobæocera incisa* Löbl**

Material examined. China, South Yunnan, Mengyang Nat. Res. ca 500m, 9-13.IX.1994, S. A. Kurbatov, 6 (MHNG).

*Distribution.* Thailand; China: Yunnan.

*Comments.* This is the only species of *Scaphobæocera* which possesses parameres notched subapically.

**Scaphobaeocera cognata** Löbl

Material examined. China, Shaanxi, Qin Lin Shan, 107°56'E 33°45'E autoroute km 93 S of Zhouzhi, 108 km southwest Xian, 1650m, mountain forest, 1-2.IX.1995, A. Pütz, 1 (PCAP); Central Sichuan, Wolong Nat. Res., 1500m, 22. and 24.V.1994, S. A. Kurbatov, 11 (MHNG); same data but 1700m, 19.V., 1 (MHNG); Yunnan, Mengyang Nat. Res. ca 500m, 10.IX.1994, S. A. Kurbatov, 1 (MHNG); Yunnan, Jizu Shan, 25°58'N, 100°21'E, 2500-2700m, 6-10.VII.1994, V. Kubán, 1 (NHMB); same data but 2800m, 20.V.-3.VI.1993, Bolm, 1 (NHMB); Yunnan, Lijiang, 26°53'N, 100°18'E, 1800m, 23.VI.-21.VII.1992, S. Bečvář, 2 (MHNG); Yunnan, Heishui, 35km north Lijiang, 27°13'N 100°19'E, 18.VI.-4.VII.1993, S. Bečvář, 1 (MHNG).

*Distribution.* North India; Nepal; China: Shaanxi, Sichuan, Yunna.

*Comments.* Females from the Wolong Nat. Res. are tentatively associated with the males. All specimens recorded from other localities are males and were dissected.

**Scaphobaeocera nobilis** Löbl

Material examined. China, South Yunnan, Mengyang Nat. Res., ca 500m, 8-12.IX.1994, S. A. Kurbatov, 9 (MHNG).

*Distribution.* Bhutan; Thailand; China: Yunnan.

**Scaphobaeocera spinigera** Löbl

Material examined. China, Central Sichuan, Wolong Nat. Res., 1500m, 21.V.1994, S. A. Kurbatov, 1 (MHNG); Hong Kong, V. and IX-X.1996, G. de Rougemont, 3 (MHNG).

*Distribution.* Pakistan; India; Nepal; Thailand; China: Sichuan, Hong Kong.

**Scaphobaeocera difficilis** Löbl

Material examined. China, West Hubei, Shennongia Nat. Res., 2000-2200m, 3-8.VI.1995, S. A. Kurbatov, 6 (MHNG).

*Distribution.* Pakistan; India; Nepal; Thailand; China: Hubei.

**Scaphobaeocera spira** Löbl

Material examined. China, Yunnan, Gaoligong Mts, 2200-2500m, 24°57'N 98°45'E, 8-16.V.1995, O. Semela, 11 (NHMB, MHNG).

*Distribution.* Nepal; Thailand; China: Yunnan.

**Scaphobaeocera dorsalis** Löbl

Material examined. China, South Yunnan, Mengyang Nat. Res., ca 500m, 8-14.IX.1994, S. A. Kurbatov, 28 (MHNG); Central Sichuan, Wolong Nat. Res., 1700, 19.V.1994, S. A. Kurbatov, 2 (MHNG).

*Distribution.* India; Nepal; Thailand, Taiwan; China: Sichuan, Yunnan.

## FIGS 64-69

Aedeagi in *Scaphobaeocera*: 64 and 65. *S. simplex* sp. n.; 66 and 67. *S. molesta* sp. n.; 68 and 69. *B. pseudovalida* sp. n. Scale bar = 0.1 mm.

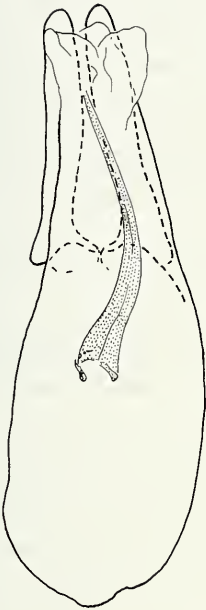

64

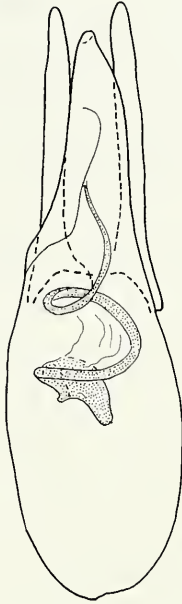

66

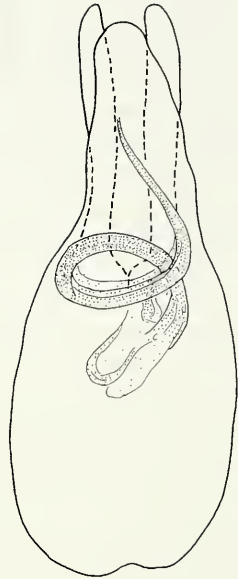

68

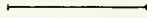

65

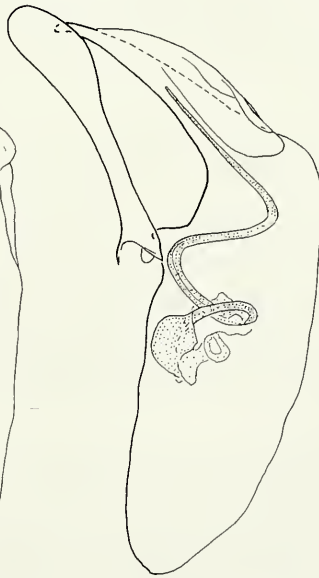

67

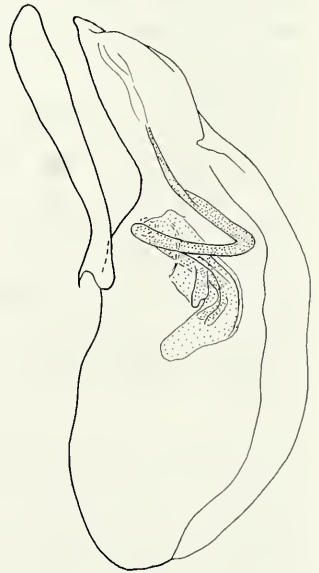

69

**Scaphobaeocera simplex** sp. n.

Figs 64, 65

Holotype ♂: China, Central Sichuan, Wolong Nat. Res., 1500m, 22.V.1994, litter, S. A. Kurbatov (MHNG).

*Description.* Length 1.4 mm, dorsoventral diameter 0.78 mm. Body very dark, almost black, with reddish lustre. Abdominal ventrites 2 to 5, coxae, femora and tibiae reddish-brown, abdominal apex and tarsi yellowish. Pronotum, elytra, lateral portions of metasternum and abdominal sternites distinctly microsculptured and iridescent. Punctuation very fine on dorsal and ventral surfaces of body. Relative length of antennal segments 3 to 11 as: 8: 10: 12: 15: 9: 13: 14: 20. Segments 3 to 6 almost equally narrow, slightly widen apically, segment 3 about 2.5 times as long as wide; segments 7 and 8 each about 2 times as long as wide; segment 11 twice as long as wide. Prohypomera without longitudinal stria. Elytra with distinct parasutural striae. Median portion of metasternum shallowly impressed, with anteriomedian stria. Metepisterna flat, about 0.10 mm wide, slightly narrowed anteriorly. Mesocoxal areas 0.02 mm long, with minute marginal pits. Basal pits of sternite I minute. Tibiae straight.

Male sexual characters. Segments 1 to 3 of protarsi strongly widen, almost as wide as apex of protibia. Aedeagus (Figs 64, 65) 0.43 mm long. Median lobe with minute ventral process, apical portion inflexed, concave ventrally, tip truncate in dorsal view, acute in lateral view. Internal sac with simple, arcuate, gradually narrowed flagellum. Parameres straight, converging apically, widen in apical two thirds.

*Comments.* This species may be easily distinguished from its congeners by the shape of the simple flagellum. *Scaphobaeocera australiensis* Löbl possesses also a flagellum very simple, but it is bent irregularly, and much narrower than in the new species. In addition, the colour patten and the shape of the median lobe in *S. australiensis* are clearly different.

**Scaphobaeocera molesta** sp. n.

Figs 66, 67

Holotype ♂: China, South Yunnan, Mengyang Nat. Res., ca 500m, 9.IX.1994, S. A. Kurbatov (MHNG).

Paratypes: same data as holotype, 1 ♂, 5 ♀; same data as holotype but 11.IX., 1 ♂; same data but 14.IX., 1 ♂ (all MHNG).

*Description.* Length 1.4-1.5 mm, dorsoventral diameter 0.80-0.86 mm. Body reddish-brown, elytra darkened toward apex. Apex of abdomen, legs and antennae lighter. Body microsculptured and iridescent. Punctuation extremely fine and indistinct on pronotum, lateral portions of metasternum and abdomen, distinct on elytra. Relative length of antennal segments 3 to 11 as: 12: 20: 22: 19: 22: 17: 24: 25: 30 (holotype). Segments 3 to 5 almost equally narrow, not widen apically, segment 3 about 3 times as long as wide; segment 6 distinctly wider than segment 5, 4 times as long as wide; segment 7 about 3 times as long as wide; segment 8 about twice as long as wide; segment 11 3 times as long as wide (holotype). Apex of scutellum exposed. Elytra with distinct parasutural striae. Prohypomera without longitudinal stria. Middle portion of metasternum flat, lacking stria or impression, distinctly, very densely punctate and pubescent. Metasternal sides microsculptured. Mesocoxal areas 0.02-0.03 mm long, with marginal pits obsolete. Metepisternum 0.04-0.05 mm wide, flat, parallel-sided, with straight suture. Basal pits of sternite I obsolete. Tibiae straight.

Male sexual characters. Segments 1 to 3 of protarsi strongly widen, segment 1 wider than base of protibiae, segment 2 about as wide as base of protibiae, segment 3 distinctly narrower than segment 2. Aedeagus (Figs 66, 67) 0.43-0.45 mm long. Median lobe with apical portion strongly inflexed, ventral process distinct, tip acute. Internal sac with flagellum narrow, forming two circles, widen basally, lacking obvious additional sclerotized pieces. Parameres straight in dorsal view, slightly curved in lateral view, rather abruptly widen apically, extending behind level of tip of median lob.

*Comments.* This species is similar and likely closely related to *S. dispar* Löbl, with which it shares most characters. It may be distinguished by the aedeagus with parameres more abruptly widen apically and the spiral flagellum of the internal sac.

**Scaphobaeocera pseudovalida** sp. n.

Figs 68, 69

Holotype ♂: China, South Yunnan, Mengyang Nat. Res., ca 500m, 11.IX.1994, litter, S. A. Kurbatov (MHNG).

Paratypes: 1 ♂ same data as holotype, 1 ♂ same data but 10.IX. (MHNG).

*Description.* Length 1.55-1.60 mm, dorsoventral diameter 0.85 mm. Body, femora and tibiae uniformly reddish-brown. Tarsi and antennae lighter than body. Body microsculptured and iridescent. Punctuation extremely fine and indistinct on pronotum, lateral portions of metasternum and abdomen, distinct on elytra. Relative length of antennal segments 3 to 11 as: 9: 16: 20: 20: 21: 17: 21: 24: 30 (holotype). Segments 3 and 4 almost equally wide, not or hardly widen apically; segment 3 about 2.5 times as long as wide; segments 5 and 6 slightly wider than segment 4; segments 4 to 6 each 4 times as long as wide; segment 7 about 3 times as long as wide, segments 8 and 11 each about 4 times as long as wide, parallel-sided. Scutellum concealed. Elytra with distinct parasutural striae. Prohypomera with deep longitudinal stria. Middle portion of metasternal flat, lacking stria, distinctly punctured and pubescent. Metasternal sides microsculptured. Mesocoxal areas 0.02-0.03 mm long, with marginal pits minute. Metepisternum 0.04-0.05 mm wide, flat, with slightly concave suture. Basal pits of sternite I obsolete. Protibiae and mesotibiae straight, metatibiae slightly curved.

Male sexual characters. Segments 1 and 3 of protarsi strongly widen, segments 1 and 2 each about as wide as base of protibiae, segment 3 slightly narrower. Aedeagus (Figs 68, 69) 0.39-0.42 mm long. Median lobe with apical portion hardly inflexed, lacking ventral process, tip blunt. Internal sac with flagellum narrow, forming one complete circle, widen basally, and with additional subbasal sclerites. Parameres almost straight, gradually widen apically, extending slightly posterior level of tip of median lobe.

*Comments.* This species is similar to *S. aberrans* Löbl, *S. pecki* Löbl, *S. robustula* Löbl and *S. valida* Löbl by the external and aedeagal characters. It may be distinguished from these four species by the long antennal segment 8. In addition, it differs from these species, except *S. valida*, by the parameres which become gradually wider in lateral view and by the flagellum of the internal sac curved in middle to form one complete circle. The new species may be distinguished from *S. valida*, in addition to the antennal characters, by the smaller size of the body and by the tip of the parameres not curved mesially.

### Scaphoxium Löbl

This genus comprises 26 species distributed in Asia, Australia, Melanesia, and New Zealand. It was not yet recorded from China. Two species of *Scaphoxium* were found in the collections examined.

#### Scaphoxium intermedium Löbl

Material examined. China. South Yunnan. Mengyang Nat. Res., ca 500m, 11.IX.1994, S. A. Kurbatov, 2 (MHNG).

*Distribution.* North India; Thailand; China: Yunnan.

*Comments.* The single Chinese specimen is a male. It possesses exactly the same aedeagal characters as the numerous specimens from India and Thailand I have examined.

#### Scaphoxium ?taiwanum Löbl

Material examined. China, Central Sichuan. Wolong Nat. Res., 1000m, 24.V.1994, S. A. Kurbatov, 3; same data but ca 500m, 15-16.V., 1; Sichuan. Mt. Emei, 1700m, 22.IX.1994, S. A. Kurbatov, 1; same data but 1000m, 4-20.V.1989, S. Kuban, 2 (all MHNG).

*Comments.* *Scaphoxium taiwanum* is known from India, Nepal, Thailand, and Taiwan. The species is well defined by the internal sac of the aedeagus which bears two pairs of conspicuous rods. The basal rods are straight, the more distal rods are apically curved, hook-like. Only two males were found in the material from China. One, from the Wolong Nat. Res., has the internal sac extruded, the second, from Mt. Emei, has the internal sac apparently deformed. Both have the hook-like sclerites more robust than those in males examined from other localities, and the pair of parallel rods untraceable.

### Toxidium LeConte

This genus is probably a paraphyletic assemblage (LÖBL 1992). The ten Asian species of *Toxidium* which are placed in the *T. aberrans* group, together with *Scaphischema poupillieri* (Reiche) from the western Mediterranean area, are similar and likely related, in respect to the remaining species assigned to *Toxidium*. An additional species comes from China and is described below. The key to the Asian species of *Toxidium* in LÖBL (1992) gives an incorrect statement in the couplet «8», concerning the basal striae of the elytra. The three involved species (*T. diffidens*, *T. pubistylis*, and *T. robustum*), possess elytra with basal striae not joined to the lateral striae. A new key is provided to replace the inconvenient couplet, and to accommodate the new species.

#### KEY TO THE ASIAN SPECIES OF *TOXIDIUM*

- |   |   |                           |
|---|---|---------------------------|
| 1 | Elytra bright reddish, with blackish adsutural and apical areas   | <i>T. spectabile</i> Löbl |
| - | Elytra unicolour or with light transverse fasciae . . . . .   | 2                         |
| 2 | Metasternum short, mesocoxal areas about as long as shortest intervals between mesocoxal lines and metacoxa . . . . . | <i>T. vagans</i> Löbl     |
| - | Metasternum long, mesocoxal area much shorter than interval between mesocoxal lines and metacoxa . . . . .            | 3                         |

- 3 Elytra without basal striae . . . . . 4  
 - Elytra with basal striae . . . . . 5  
 4 Elytral punctation fine and irregular. Parameres of aedeagus smooth  
 . . . . . *T. incompletum* Löbl  
 - Elytral punctation coarse and fairly regular. Parameres of aedeagus  
 pubescent . . . . . *T. villosum* sp. n.  
 5 Mesepimeral ridge present. Lateral portions of metasternum fairly coar-  
 sely punctate . . . . . *T. indicum* Achard  
 - Mesepimeral ridge absent. Lateral portions of metasternum very finely  
 punctate . . . . . 6  
 6 Pronotal punctation coarse, distinct at 12x magnification . . . *T. aberrans* Achard  
 - Pronotal punctation very fine, hardly visible at 24x magnification . . . . . 7  
 7 Elytra with sutural striae long, starting neat elytral base . . . . . 8  
 - Elytra with sutural striae very short, present only near elytral apices . . . . . 9  
 8 Elytra entirely coarsely punctate. . . . . *T. curtilineatum* Champion  
 - Apical portion of elytra finely punctate . . . . . *T. stylicherum* Löbl  
 9 Internal sac of aedeagus with long, apically bifid rod and short, V-shaped  
 subapical sclerite . . . . . *T. pubistylis* Löbl  
 - Internal sac of aedeagus with sclerotized rod not bifid, and without  
 additional sclerite . . . . . 10  
 10 Internal sac of aedeagus with moderately long, sclerotized rod widen  
 apically, extended about to level of basis of parameres . . . . . *T. diffidens* Löbl  
 - Internal sac of aedeagus with very long, sclerotized rod narrowed api-  
 cally, extended almost to mid-length of parameres . . . . . *T. robustum* Pic

**Toxidium villosum** sp. n.

Figs 70-72

Holotype ♂: China, Central Sichuan, Wolong Nat. Res., 1500m, 21.V.1994, S. A. Kurbatov (MHNG).

Paratypes: same data as holotype. 1 ♂, 1 ♀; same data but 22.V., 1 ♂ (all MHNG).

*Description.* Length 2.40-2.70 mm. Body black, apices of elytra lighter, apical abdominal segments light brown. Femora and tibiae dark reddish-brown, antennae and tarsi light brown. Relative length of antennal segments 3 to 11 as: 20: 25: 25: 22: 25: 20: 25: 25: 26; segments 3 to 6 equally narrow. Pronotal punctation dense and fairly coarse, distinct at 24 times magnification. Tip of scutellum exposed. Elytra with sutural stria strongly reduced, very shallow and short, present only on inflexed area near apex; basal stria absent; lateral and epipleural striae gradually converging toward apex; elytral punctation dense and coarse, intervals usually slightly larger than, but upto 2.5 times as large as, puncture diameters. Metathoracic wings fully developed. Mesosternal shield punctate, with narrow median ridge. Mesepimeral ridge absent. Middle portion of metasternum with very shallow impression; metasternal punctation sparse, fine, irregular. Mesocoxal line convex, mesocoxal area 0.06-0.08 mm long, about as long as 1/4 to 1/3 of shortest interval between mesocoxal line and metacoxa; marginal pits fairly fine. Metepisternum flat, evenly wide, with deep, fairly wide, straight suture. Pygidium

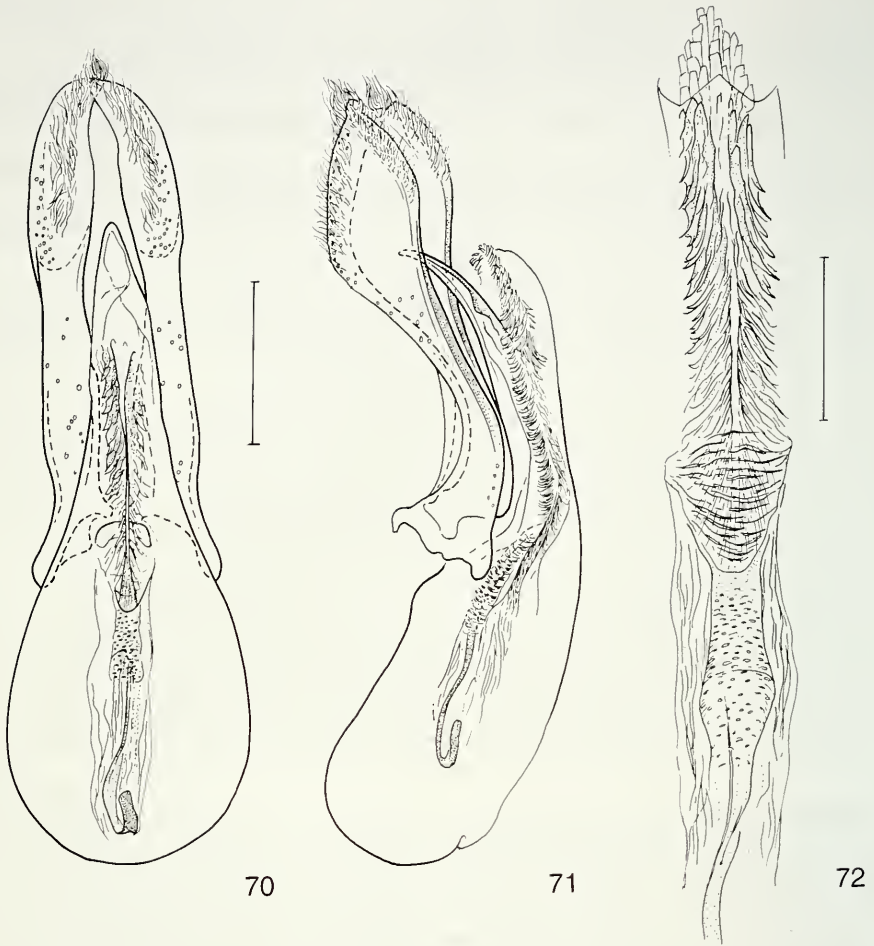

FIGS 70-72

Aedeagus in *Toxidium villosum* sp. n. Scale bars = 0.2 mm in figs 70, 71; = 0.1 mm in fig. 72.

and abdominal sternites very finely punctate, with extremely fine microsculpture consisting of punctures. Protibiae straight, mesotibiae and metatibiae slightly curved.

Male sexual characters. Segments 1-3 of protarsi strongly widen. Aedeagus (Figs 60-72) 0.95 mm long. Apical portion of median lobe gradually narrowed, obliquely inflexed, convexly rounded near tip (lateral view). Parameres sinuate and moderately widen apically in dorsal view, inflexed and strongly widen apically in lateral view, with inconspicuous apicodorsal lobe, finely pubescent. Internal sac denticulate in apical half, with long, narrow, ventrobasal rod and central, straight rod.



*Comments.* This species appears to be closely related with *T. pubistylis* Löbl with which it shares the parameres strongly widen and pubescent apically. It may be easily distinguished from *T. pubistylis* and other congeners, *T. incompletum* Löbl excepted, by the absence of the elytral basal striae. The new species differs from *T. incompletum* by the much more coarse pronotal and elytral punctuation and by the distinct metasternal and mesosternal punctuation. These two species may be also easily distinguished by their aedeagal characters, especially by the absence of denticles in the internal sac of *T. incompletum*.

#### ACKNOWLEDGEMENTS

I thank all friends and colleagues who continuously provided material from their collections: S. Bečvář (České Budějovice), J. Cooter (Hereford), J. Farkač (Praha), J. Horák (Praha), D. Král (Praha), V. Kubán (Brno), S. A. Kurbatov (Moscow), A. Pütz (Eisenhüttenstadt), G. de Rougemont (London), M. Schülke (Berlin) and A. Smetana (Ottawa). My colleagues N. Berti (MNHN), D. Borisch (NHRM), M. Brancucci (NMHB), J. Jelínek (NMPC), C. Johnson (MMUE) and W. Schawaller (SMNS) made type and other material available for study. Mrs N. Lavoyer illustrated the colour pattern of several species of *Scaphidium*.

#### REFERENCES

- ACHARD, J. 1920a (1919). Description d'un nouveau *Scaphosoma* du Yunnan (Col. Scaphidiidae). *Annales de la Société entomologique de France* 88: 328.
- ACHARD, J. 1920b. Synopsis des *Scaphidium* (Col. Scaphidiidae) de l'Indo-Chine et du Yunnan. *Bulletin de la Société entomologique de France* 1920: 209-212.
- ACHARD, J. 1920c. Notes sur les Scaphidiidae de la faune Indo-Malaise. *Annales de la Société entomologique de Belgique* 60: 123-136.
- FAIRMAIRE, L. 1886. Descriptions de Coléoptères de l'intérieur de la Chine. *Annales de la Société entomologique de France* 1886: 303-356.
- LAFER, G.SH. 1989. Sem. Scaphidiidae - Tchernovidki, pp. 367-373. *In*: LER, P. A. (ed.). *Opredelitel nasekomykh Dalnego Vostoka SSSR. Tom III. Zhestkokrylie, ili zhuki. Tchast I. Nauka, Leningrad.*
- LESCHEN, R. A. B. & LÖBL, I. 1995. Phylogeny of Scaphidiinae with redefinition of tribal and generic limits (Coleoptera: Staphylinidae). *Revue suisse de Zoologie* 102: 425-474.
- LI, J. 1992. The Coleoptera Fauna of Northeast China. *Jilin Education Publishing House*, 205 pp.
- LI, J. & CHEN, P. 1993. Studies on fauna and ecogeography of soil animal. *Press of Northeast Normal University*, 265 pp.
- LÖBL, I. 1965. Beitrag zur Kenntnis der *Scaphosoma*-Arten Chinas (Coleoptera, Scaphidiidae). *Reichenbachia* 6: 25-31.
- LÖBL, I. 1966. Neue und interessante paläarktische Scaphidiidae aus dem Museum G. Frey (Col.). *Entomologische Arbeiten aus dem Museum G. Frey* 17: 129-134.
- LÖBL, I. 1968. Description of *Scaphidium comes* sp. n. and notes on some other palaeartic species of the genus *Scaphidium* (Coleoptera, Scaphidiidae). *Acta entomologica bohemoslovaca* 65: 386-390.
- Löbl, I. 1970. Revision der paläarktischen Arten der Gattungen *Scaphisoma* Leach und *Caryoscapha* Ganglbauer der Tribus Scaphisomini (Col. Scaphidiidae). *Revue suisse de Zoologie* 77: 727-799.

- LÖBL, I. 1972. Beitrag zur Kenntnis der Scaphidiidae (Coleoptera) von China und Japan. *Notulae entomologicae* 52: 115-118.
- LÖBL, I. 1979. Die Scaphidiidae (Coleoptera) Südindiens. *Revue suisse de Zoologie* 86: 77-129.
- LÖBL, I. 1881. Über die japanischen Arten der Gattungen *Scaphobaeocera* Csiki und *Scaphoxium* Löbl (Col., Scaphidiidae). *Mitteilungen der Schweizerischen Entomologischen Gesellschaft* 54: 229-244.
- LÖBL, I. 1984a. Contribution à la connaissance des *Baeocera* du Japon (Coleoptera, Scaphidiidae). *Archives des Sciences* (Genève) 37: 181-192.
- LÖBL, I. 1984b. Scaphidiidae (Coleoptera) de Birmanie et de Chine nouveaux ou peu connus. *Revue suisse de Zoologie* 91: 993-1005.
- LÖBL, I. 1990a. *Cyparium javanum* n. sp., a new Scaphidiidae (Coleoptera) from Indonesia. *Elytron* 4: 125-129.
- LÖBL, I. 1990b. Review of the Scaphidiidae of Thailand. *Revue suisse de Zoologie* 97: 505-621.
- LÖBL, I. 1992. The Scaphidiidae (Coleoptera) of the Nepal Himalaya. *Revue suisse de Zoologie* 99: 471-627.
- LÖBL, I. 1993. Contribution to the knowledge of the Scaphidiinae (Coleoptera, Staphylinidae) of the Far East Region of Russia. *Russian Entomological Journal* 2: 35-40.
- LÖBL, I. 1997. Catalogue of the Scaphidiinae (Coleoptera: Staphylinidae). *Instrumenta biodiversitatis* I: xii + 190 pp.
- LÖBL, I. & STEPHAN, K. 1993. A review of the species of *Baeocera* Erichson (Coleoptera, Staphylinidae, Scaphidiinae) of America north of Mexico. *Revue suisse de Zoologie* 100: 675-733.
- MIWA, Y. & MITONO, T. 1943. Scaphidiidae of Japan and Formosa. *Transactions of the Natural History Society of Formosa* 33: 512-555 (in Japanese).
- PIC, M. 1916. Diagnoses spécifiques. *Mélanges exotico-entomologiques* 17: 8-20.
- PIC, M. 1920. Nouveautés diverses. *Mélanges exotico-entomologiques* 32: 1-28.
- PIC, M. 1954. Coléoptères nouveaux de Chine. *Bulletin de la Société entomologique de Mulhouse* 1954: 53-59.
- ROUGEMONT, G. DE. 1996. Scaphidiids in Hong Kong. *Porcupine* 15: 12.
- SHIROZU, T. & MORIMOTO, K. 1963. A contribution towards the knowledge of the genus *Scaphidium* Olivier of Japan (Coleoptera, Scaphidiidae). *Sieboldia* 3: 55-90.

REVUE SUISSE DE ZOOLOGIE

Tome 106 — Fascicule 3

	Pages
FRISCH, Johannes. A revision of the <i>Scopaeus sulcicollis</i> species group, with description of a new species from North-East Anatolia (Coleoptera, Staphylinidae, Paederinae). . . . .	539-553
ADIS, Joachim, Ulf SCHELLER, José Wellington de MORAIS & José Maria G. RODRIGUES. Abundance, species composition and phenology of Pauropoda (Myriapoda) from a secondary upland forest in Central Amazonia. . . . .	555-570
MANCONI, Renata & Ruth DESQUEYROUX-FAÚNDEZ. Freshwater sponges (Porifera, Spongillidae) from the Lake of Geneva, Switzerland. . . . .	571-580
HANZELOVÁ, Vladimira, Tomáš SCHOLZ, Daniel GERDEAUX & Alain de CHAMBRIER. Endoparasitic helminths of fishes in three Alpine lakes in France and Switzerland. . . . .	581-590
LOURENÇO, Wilson R. Un nouveau genre et une nouvelle espèce de scorpion d'Égypte, appartenant à la famille des Buthidae Simon. . . . .	591-598
GARETTO, Roberta & Pier Mauro GIACHINO. Nuovi Anillina (Coleoptera, Carabidae: Bembidiini) del Kenya. . . . .	599-610
VAUCHER, Claude & Marie-Claude DURETTE-DESSET. <i>Histiostrongylus spineus</i> n. sp. (Nematoda: Trichostrongylina), parasite de <i>Phyllostomus discolor</i> (Chiroptera: Phyllostomidae) et nouvelles données sur les genres <i>Histiostrongylus</i> Molin, 1861 et <i>Parahistiostrongylus</i> Perez Viguera, 1941. . . . .	611-620
RUŽIČKA, Jan. A new apterous and microphthalmic species of <i>Anemadus</i> (Coleoptera: Leiodidae: Cholevinae) from China. . . . .	621-626
BENTOS-PEREIRA, Alba & C. Hugh F. ROWELL. The genus <i>Proscopia</i> Klug, 1820 (Orthoptera, Caelifera, Eumastacoidea, Proscopiidae) in Central America, with description of a new species. . . . .	627-641
HOESS, René & Adolf SCHOLL. <i>Glomeris undulata</i> Koch and <i>G. conspersa</i> Koch are conspecific. - Enzyme electrophoretic evidence and taxonomical consequences (Diplopoda: Glomeridae). . . . .	643-661
PACE, Roberto. Aleocharinae di Hong Kong (Coleoptera, Staphylinidae). . . . .	663-689
LÖBL, Ivan. A review of the Scaphidiinae (Coleoptera: Staphylinidae) of the People's Republic of China, I. . . . .	691-744

REVUE SUISSE DE ZOOLOGIE

Volume 106 — Number 3

Pages

FRISCH, Johannes. A revision of the <i>Scopaeus sulcicollis</i> species group, with description of a new species from North-East Anatolia (Coleoptera, Staphylinidae, Paederinae). . . . .	539
ADIS, Joachim, Ulf SCHELLER, José Wellington de MORAIS & José Maria G. RODRIGUES. Abundance, species composition and phenology of Pauropoda (Myriapoda) from a secondary upland forest in Central Amazonia. . . . .	555
MANCONI, Renata & Ruth DESQUEYROUX-FAÚNDEZ. Freshwater sponges (Porifera, Spongillidae) from the Lake of Geneva, Switzerland. . . . .	571
HANZELOVÁ, Vladimira, Tomáš SCHOLZ, Daniel GERDEAUX & Alain de CHAMBRIER. Endoparasitic helminths of fishes in three Alpine lakes in France and Switzerland. . . . .	581
LOURENÇO, Wilson R. New genus and new species of scorpion from Egypt, belonging to the family Buthidae Simon. . . . .	591
GARETTO, Roberta & Pier Mauro GIACHINO. New species of Anillina (Coleoptera, Carabidae: Bembidiini) from Kenya. . . . .	599
VAUCHER, Claude & Marie-Claude DURETTE-DESSET. <i>Histiostrongylus spinus</i> n. sp. (Nematoda: Trichostrongylina), parasite of <i>Phyllostomus discolor</i> (Chiroptera: Phyllostomidae), and comments on the genera <i>Histiostrongylus</i> Molin, 1861 and <i>Parahistiostrongylus</i> Perez Vigueras, 1941. . . . .	611
RUŽIČKA, Jan. A new apterous and microphthalmic species of <i>Anemadus</i> (Coleoptera: Leiodidae: Cholevinae) from China. . . . .	621
BENTOS-PEREIRA, Alba & C. Hugh F. ROWELL. The genus <i>Proscopia</i> Klug, 1820 (Orthoptera, Caelifera, Eumastacoidea, Proscopiidae) in Central America, with description of a new species. . . . .	627
HOESS, René & Adolf SCHOLL. <i>Glomeris undulata</i> Koch and <i>G. conspersa</i> Koch are conspecific. - Enzyme electrophoretic evidence and taxonomical consequences (Diplopoda: Glomeridae). . . . .	643
PACE, Roberto. Aleocharinae from Hong Kong (Coleoptera, Staphylinidae). . . . .	663
LÖBL, Ivan. A review of the Scaphidiinae (Coleoptera: Staphylinidae) of the People's Republic of China, I. . . . .	691

**Indexed in** CURRENT CONTENTS, SCIENCE CITATION INDEX

PUBLICATIONS DU MUSÉUM D'HISTOIRE NATURELLE DE GENÈVE

CATALOGUE DES INVERTÉBRÉS DE LA SUISSE, N <sup>os</sup> 1-17 (1908-1926) . . . . .	série Fr. 285.—
(prix des fascicules sur demande)	
REVUE DE PALÉO BIOLOGIE . . . . .	Echange ou par fascicule Fr. 35.—
LE RHINOLOPHE (Bulletin du centre d'étude des chauves-souris) . . . . .	par fascicule Fr. 35.—
COLLEMBOLFAUNA EUROPAS von H. GISIN, 312 Seiten, 554 Abbildungen, 1960 (Nachdruck, 1984) . . . . .	Fr. 30.—
THE EUROPEAN PROTURA THEIR TAXONOMY, ECOLOGY AND DISTRIBUTION WITH KEYS FOR DETERMINATION by J. NOSEK, 346 pages, 111 figures in text, 1973 . . . . .	Fr. 30.—
CLASSIFICATION OF THE DIPLOPODA par Richard L. HOFFMAN, 237 pages, 1979 . . . . .	Fr. 30.—
LES OISEAUX NICHEURS DU CANTON DE GENÈVE par P. GÉROUDET, C. GUEX et M. MAIRE 351 pages, nombreuses cartes et figures, 1983 . . . . .	Fr. 45.—
CATALOGUE COMMENTÉ DES TYPES D'ECHINODERMES ACTUELS CONSERVÉS DANS LES COLLECTIONS NATIONALES SUISSES, SUIVI D'UNE NOTICE SUR LA CONTRIBUTION DE LOUIS AGASSIZ À LA CONNAISSANCE DES ECHINODERMES ACTUELS par Michel JANGOUX, 67 pages, 11 planches, 1985 . . . . .	Fr. 15.—
RADULAS DE GASTÉROPODES LITTORAUX DE LA MANCHE (COTENTIN-BAIE DE SEINE, FRANCE) par Y. FINET, J. WÜEST et K. MAREDA, 62 pages, 1991 . . . . .	Fr. 10.—
GASTROPODS OF THE CHANNEL AND ATLANTIC OCEAN; SHELLS AND RADULAS by Y. FINET, J. WÜEST and K. MAREDA, 1992 . . . . .	Fr. 30.—
O. SCHMIDT SPONGE CATALOGUE par R. DESQUEYROUX-FAUNDEZ & S.M. STONE, 190 pages, 49 plates, 1992 . . . . .	Fr. 40.—
ATLAS DE RÉPARTITION DES AMPHIBIENS ET REPTILES DU CANTON DE GENÈVE par A. KELLER, V. AELLEN et V. MAHNERT, 48 pages, 1993 . . . . .	Fr. 15.—
THE MARINE MOLLUSKS OF THE GALAPAGOS ISLANDS: A DOCUMENTED FAUNAL LIST par Yves FINET, 180 pages, 1995 . . . . .	Fr. 30.—
NOTICE SUR LES COLLECTIONS MALACOLOGIQUES DU MUSEUM D'HISTOIRE NATURELLE DE GENEVE par Jean-Claude CAILLIEZ, 49 pages, 1995 . . . . .	Fr. 22.—
PROCEEDINGS OF THE XIIIth INTERNATIONAL CONGRESS OF ARACHNOLOGY, Geneva 1995 (ed. Volker MAHNERT), 720 pages, 1996 . . . . .	Fr. 160.—
CATALOGUE OF THE SCAPHIDIINAE (COLEOPTERA: STAPHYLINIDAE) ( <i>Instrumenta Biodiversitatis</i> I) par Ivan LÖBL, 192 pages, 1997 . . . . .	Fr. 50.—
CATALOGUE SYNONYMIQUE ET GÉOGRAPHIQUE DES SYRPHIDAE (DIPTERA) DE LA RÉGION AFROTROPICALE ( <i>Instrumenta Biodiversitatis</i> II) par Henri G. DIRICKX, 188 pages, 1998 . . . . .	Fr. 50.—
A REVISION OF THE CORYLOPHIDAE (COLEOPTERA) OF THE WEST PALAEARCTIC REGION ( <i>Instrumenta Biodiversitatis</i> III) par Stanley BOWESTEAD, 204 pages, 1999 . . . . .	Fr. 60.—



## *Revue suisse de Zoologie: Instructions to Authors*

The *Revue suisse de Zoologie* publishes papers by members of the Swiss Zoological Society and scientific results based on the collections of the Muséum d'histoire naturelle, Geneva. Submission of a manuscript implies that it has been approved by all named authors, that it reports their unpublished work and that it is not being considered for publication elsewhere. A financial contribution may be asked from the authors for the impression of colour plates and large manuscripts. All papers are refereed by expert(s).

In order to facilitate publication and avoid delays authors should follow the *Instructions to Authors* and refer to a current number of R.S.Z. for acceptable style and format. Manuscripts not conforming with these directives are liable to be returned to the authors. Papers may be written in French, German, Italian and English. Authors should aim to communicate ideas and information clearly and concisely in language suitable for the moderate specialist. Authors not writing in their native language should pay particular attention to the linguistic quality of the text.

Manuscripts must be typed, on one side only and double-spaced, on A4 (210 x 297 mm) or equivalent paper and all pages should be numbered. All margins must be at least 25 mm wide. Authors must submit one original and two copies, including tables and figures, in final fully corrected form, and are expected to retain another copy.

Papers should conform to the following general layout:

**Title page.** A concise but informative full title plus a running title of not more than 40 letters and spaces, name(s) in full and surname(s) of author(s), and full address(es).

**Abstract.** The abstract is in English, composed of the title and a short text of up to 200 words. It should summarise the contents and conclusions of the paper. The abstract is followed by less than 10 key-words, separated by hyphens, which are suitable for indexing.

**Introduction.** A short introduction to the background and the reasons for the work.

**Materials and methods.** Sufficient experimental details must be given to enable other workers to repeat the work. The full binominal name should be given for all organisms. The Zoological Code must be strictly followed. Cite the authors of species on their first mention. Use SI units and the appropriate symbols.

**Results.** These should be concise and should not include methods or discussion. Text, tables and figures should not duplicate the same information. New taxa must be distinguished from related taxa. The abbreviations gen. n., sp. n., syn. n. and comb. n. should be used to distinguish all new taxa, synonymies or combinations. Primary types should be deposited in a museum or similar institution. In taxonomic papers the species heading should be followed by synonyms, material examined and distribution, description and comments. All material examined should be listed in similar, compact and easily intelligible format; the information should be in the same language as the text.

Sex symbols should be used rather than "male" and "female".

**Discussion.** This should not be excessive and should not repeat results nor contain new information, but should emphasize the significance and relevance of the results reported.

**References.** The Harvard System must be used for the citation of references in the text, e.g. White & Green (1995) or (White & Green 1995). For references with three and more authors the form Brown *et al.* should be used. Authors' names should not be written in capitals. The list of references must include all publications cited in the text but only these. References must be listed in alphabetical order of authors, and both the title and name of the journal must be given in full in the following style:

Penard, E. 1888. Recherches sur le *Ceratium macroceros*. Thèse. Genève, 43 pp.

Penard, E. 1889. Etudes sur quelques Hélozoaires d'eau douce. *Archives de Biologie* 9: 1-61.

Mertens, R. & Wermuth, H. 1960. Die Amphibien und Reptilien Europas. *Kramer, Frankfurt am Main*, XI + 264 pp.

Handley, C. O. Jr. 1966. Checklist of the mammals of Panama, pp. 753-795. In: Wenzel R. L. & Tipton, V. J. (eds).

Ectoparasites of Panama. *Field Museum of Natural History, Chicago*, XII + 861 pp.

References should not be interspaced and, in the case of several papers by the same author, the name has to be repeated for each reference.

The text should be in roman (standard) type face throughout, including headings, with genus and species names underlined with pencil; bold, small capitals, large capitals, italics and other type faces should not be used. Footnotes and cross-references by page should be avoided.

Also, we encourage authors to submit the text on floppy disk (3.5" or 5 1/4", Macintosh or IBM compatible, with "Microsoft Word" or similar programmes). The authors should refrain from using special codes for text formatting.

**Tables.** These should be self-explanatory, with the title at the top organised to fit 122 x 180 mm. Each table should be typed, double spaced, on a separate page and numbered consecutively and its position indicated in the text.

**Figures.** These may be line drawings or half tones and all should be numbered consecutively, and their position indicated in the text. Figures should be arranged in plates which can be reduced to 122 x 160 mm. Drawings and lettering should be prepared to withstand reduction. Magnification should be indicated with scale lines. Authors should refrain from mixing the drawings and half tones. Original drawings will not be returned automatically. The *Revue suisse de Zoologie* declines responsibility for lost or damaged slides or other documents.

**Legends to figures.** These should be typed in numerical order on a separate sheet.

**Proofs.** Page proofs only are supplied, and authors may be charged for alterations (other than printer's errors) if they are numerous.

**Offprints.** The authors receive 25 offprints free of charge; more copies may be ordered at current prices when proofs are returned.

**Correspondence.** All correspondence should be addressed to

Revue suisse de Zoologie  
Muséum d'histoire naturelle  
CP 6434

CH-1211 Genève 6  
Switzerland.

Phone: (022) 418 63 33 - Fax (022) 418 63 01

e-mail: volker.mahner@mhn.ville-ge.ch

Home page RSZ: <http://www-geneva-city.ch:80/musinfo/mhng/publications/revues.htm>





454  
#

ANNALES

de la  
SOCIÉTÉ SUISSE DE ZOOLOGIE  
et du  
MUSÉUM D'HISTOIRE NATURELLE  
de la Ville de Genève

tome 106  
fascicule 4  
1999

SWISS JOURNAL OF ZOOLOGY

REVUE SUISSE DE ZOOLOGIE



# REVUE SUISSE DE ZOOLOGIE

TOME 106 — FASCICULE 4

Publication subventionnée par:  
ACADÉMIE SUISSE DES SCIENCES NATURELLES ASSN  
VILLE DE GENÈVE  
SOCIÉTÉ SUISSE DE ZOOLOGIE

VOLKER MAHNERT  
Directeur du Muséum d'histoire naturelle de Genève

FRANÇOIS BAUD  
Conservateur au Muséum d'histoire naturelle de Genève

CHARLES LIENHARD  
Chargé de recherche au Muséum d'histoire naturelle de Genève

## *Comité de lecture*

Président: Ivan LÖBL — Muséum de Genève

Il est constitué en outre du président de la Société suisse de Zoologie, du directeur du Muséum de Genève et de représentants des Instituts de zoologie des universités suisses.

Les manuscrits sont soumis à des experts d'institutions suisses ou étrangères selon le sujet étudié.

La préférence sera donnée aux travaux concernant les domaines suivants: biogéographie, systématique, écologie, éthologie, morphologie et anatomie comparée, physiologie.

## *Administration*

MUSÉUM D'HISTOIRE NATURELLE  
1211 GENÈVE 6

Internet: <http://www.ville-ge.ch/musinfo/mhng/page/rsz.htm>

### PRIX DE L'ABONNEMENT:

SUISSE Fr. 225.—

UNION POSTALE Fr. 230.—  
(en francs suisses)

Les demandes d'abonnement doivent être adressées  
à la rédaction de la *Revue suisse de Zoologie*,  
Muséum d'histoire naturelle, C.P. 6434, CH-1211 Genève 6, Suisse

ANNALES

de la  
SOCIÉTÉ SUISSE DE ZOOLOGIE  
et du  
MUSÉUM D'HISTOIRE NATURELLE  
de la Ville de Genève

tome 106  
fascicule 4  
1999



GENÈVE DÉCEMBRE 1999 ISSN 0035 - 418 X

SWISS JOURNAL OF ZOOLOGY

REVUE SUISSE DE ZOOLOGIE

# REVUE SUISSE DE ZOOLOGIE

TOME 106 — FASCICULE 4

Publication subventionnée par:  
ACADÉMIE SUISSE DES SCIENCES NATURELLES ASSN  
VILLE DE GENÈVE  
SOCIÉTÉ SUISSE DE ZOOLOGIE

VOLKER MAHNERT  
Directeur du Muséum d'histoire naturelle de Genève

FRANÇOIS BAUD  
Conservateur au Muséum d'histoire naturelle de Genève

CHARLES LIENHARD  
Chargé de recherche au Muséum d'histoire naturelle de Genève

## Comité de lecture

Président: Ivan LÖBL — Muséum de Genève

Il est constitué en outre du président de la Société suisse de Zoologie, du directeur du Muséum de Genève et de représentants des Instituts de zoologie des universités suisses.

Les manuscrits sont soumis à des experts d'institutions suisses ou étrangères selon le sujet étudié.

La préférence sera donnée aux travaux concernant les domaines suivants: biogéographie, systématique, écologie, éthologie, morphologie et anatomie comparée, physiologie.

## Administration

MUSÉUM D'HISTOIRE NATURELLE  
1211 GENÈVE 6

Internet: <http://www.ville-ge.ch/musinfo/mhng/page/rsz.htm>

### PRIX DE L'ABONNEMENT:

SUISSE Fr. 225.—

UNION POSTALE Fr. 230.—  
(en francs suisses)

Les demandes d'abonnement doivent être adressées  
à la rédaction de la *Revue suisse de Zoologie*,  
Muséum d'histoire naturelle, C.P. 6434, CH-1211 Genève 6, Suisse

## ZOOLOGIA ET BOTANICA '99

Zurich, 17-19 February 1999

(Joint meeting of the Swiss Society of Zoology and the Swiss Society of Botany)

17 February 1999: **Satellite Symposium: Evolution, Ecology and Behaviour**

18-19 February 1999: **Main Symposium: Genes, Populations and Politicians:  
Issues in Conservation Biology**

### Author Index

**ANHOLT Bradley R.**, see THURNHEER Sylvie *et al.*

**ANTOINE Céline, MÜLLER Jessica & CASTELLA Emmanuel**

Assemblages of freshwater molluscs in a fringing wetland (Lake Neuchâtel, Switzerland)

see also OERTLI Beat *et al.*

**ARNOLD Claire, GILLET François & GOBAT Jean-Michel**

Ecological knowledge and species conservation: the example of the European wild grapevine *Vitis vinifera* subsp. *sylvestris* (Gmel.) Hegi

**AUDERSET-JOYE Dominique**, see OERTLI Beat *et al.*

**BAER Boris, MAILE Roland, SCHMID-HEMPEL Paul, MORGAN E. David & JONES Graeme R.**

Chemistry and possible function of a mating plug in bumblebees

**BAER Boris & SCHMID-HEMPEL Paul**

Multiple mating: an advantage against parasites

**BAKKER Theo C. M.**, see KUENZLER Reto *et al.*

**BALLOUX François**, see LUGON-MOULIN Nicolas *et al.* & PERRIN Nicolas *et al.*

**BAZIN Alain**, see GOVERDE Marcel *et al.*

**BERSIER Louis-Félix**, see HOFER Ulrich *et al.*

**BOLLENS Ursula & RYSER Peter**

Nutrients and water regime: Effects on 16 wetland species

**BORCARD Daniel**, see HOFER Ulrich *et al.*

**BRASCHLER Brigitte**

Influences of small-scale habitat fragmentation on ants

**BRÄUER Ingo**, see MATTHIES Diethart *et al.*

**BREM Dominik & LEUCHTMANN Adrian**

Transmission mode of a grass endophyte with mixed strategy of reproduction

**BRUNNER Harald**, see LUGON-MOULIN Nicolas *et al.*

**BÜCHLER Urs**, see GUGERLI Felix *et al.*

**CAMBIN Diana**, see CASTELLA Emmanuel *et al.*, OERTLI Beat *et al.* & PULFER Corinne *et al.*

**CASTELLA Emmanuel, LODS-CROZET Brigitte, CAMBIN Diana, ILG Christiane, KNISPEN Sandra, MARION Thomas, MARMONIER Pierre & SIMANT Hélène**

Physical habitat and zoobenthic diversity of a glacial stream (the Mutt, Swiss Alps)

**CASTELLA Emmanuel, SPEIGHT Martin C. D. & GOELDIN DE TIEFENAU Pierre**

Using species pool and digitised biological data for biodiversity assessment and conservation: a test case with Syrphidae (Diptera)

see also ANTOINE Céline *et al.*, ILG Christiane *et al.*, OERTLI Beat *et al.* & PULFER Corinne *et al.*

**CASTELLA Vincent, RUEDI Manuel, EXCOFFIER Laurent & IBANEZ Carlos**

Do males and females mouse-eared bats cross the Gibraltar Strait? Molecular markers say no!

**CHAUTEMS Alain**, see PERRET Mathieu *et al.*

**CONEDERA Marco**, see MORETTI Marco *et al.*

**DEGEN Thomas**, see GOINGUENE Sandrine *et al.*

**DI GIULIO Manuela, EDWARDS Peter J. & MEISTER Erhard**

Enhancing insect diversity in agricultural grasslands: the role of management and landscape structure

**DIETRICH Barbara & WEHNER Rüdiger**

Coexistence of parapatric species: how do desert ants solve this contradiction ?

**DUELLI Peter**, see MORETTI Marco *et al.*

**EDWARDS Peter J.**, see DI GIULIO Manuela *et al.*, KELLER Michael *et al.*, MORETTI Marco *et al.*, STUDER Sibylle *et al.* & ULLRICH Karin S. *et al.*

**EK Liina**, see RYSER Peter *et al.*

**ERHARDT Andreas**, see GOVERDE Marcel *et al.* & RUSTERHOLZ Hans-Peter *et al.*

**EXCOFFIER Laurent**, see CASTELLA Vincent *et al.*

**FINKELDEY Reiner**

Molecular markers and the conservation of forest resources - is there an impact ?

**FISCHER Markus, VAN KLEUNEN Mark & SCHMID Bernhard**

Relations among population size, genetic variation, and plant performance: the example of *Ranunculus reptans*

**FORSTNER Michael R. J.**, see PASTORINI Jennifer *et al.*

**FREIMANN Barbara & WARD Paul I.**

Male seminal products influence female sperm storage muscles in *Scathophaga stercoraria*

**FREYMOND Hervé & GALLAND Nicole**

Genetic diversity and conservation of *Saxifraga hirculus*

**FUMAGALLI Luca & TABERLET Pierre**

Genetic affiliation of historical wolves from Switzerland

**GAECHTER Fani**, see ROY Bitty *et al.*

**GALEUCHET David J., RUTISHAUSER Rolf & SCHNELLER Johann Jakob**

*Typha minima* - formerly common, now endangered. Genetic variability and relationship between fragmented and ex situ populations

**GALLAND Nicole**, see FREYMOND Hervé *et al.*

**GANTENBEIN Benjamin, LARGIADER Carlo R. & SCHOLL Adolf**

Nuclear and mitochondrial gene variation among populations of *Buthus occitanus* (Amoreux, 1789) across the Strait of Gibraltar

**GAUTSCHI Barbara & TENZER Isabel**

Development of microsatellite markers for the Bearded Vulture (*Gypaetus barbatus*) and their application to the reintroduction project

**GEBHARDT-HENRICH Sabine**

Reproductive success was predicted by body mass loss in female great tits (*Parus major*)

**GERLOFF Christine U., OTTMER Birgit K. & SCHMID-HEMPEL Paul**

Inbreeding in bumble bees

**GILLET François**, see **ARNOLD Claire** *et al.***GOBAT Jean-Michel**, see **ARNOLD Claire** *et al.***GOEDLIN DE TIEFENAU Pierre**, see **CASTELLA Emmanuel** *et al.***GOUDET Jérôme**

A population genetics view of multivariate statistical methods  
see also **LUGON-MOULIN Nicolas** *et al.* & **PERRIN Nicolas** *et al.*

**GOUINGUENE Sandrine, DEGEN Thomas & TURLINGS Ted**

How parasitoids of caterpillars find suitable hosts ?

**GOVERDE Marcel, BAZIN Alain, SHYKOFF Jacqui & ERHARDT Andreas**

Influence of leaf chemistry of *Lotus corniculatus* (Fabaceae) on larval development of *Polyommatus icarus* (Lepidoptera, Lycaenidae): effects of elevated CO<sub>2</sub> and plant genotype

**GUGERLI Felix, SPERISEN Christoph, BÜCHLER Urs & SENN Josef**

Genetic diversity in tree species of subalpine forests: a case study of Norway spruce (*Picea abies*)

**GÜSEWELL Sabine**

Does the public support restoration measures in fen meadows invaded by common reed ?

**HAGGSTRÖM Hakan, RAHIER Martine & HARTMANN Thomas**

Deterrent effect of pyrrolizidine alkaloids and detoxification by a generalist predator (*Mitopus morio*)

**HARTMANN Thomas**, see **HAGGSTRÖM Hakan** *et al.***HAUSSER Jacques**, see **LUGON-MOULIN Nicolas** *et al.***HEEB Philipp**

Within-pair copulation frequency predicts female reproductive performance in tree sparrows, *Passer montanus*

**HELLRIEGEL Barbara & REYER Heinz-Ulrich**

Which factors influence the composition of mixed populations of a hemiclinal hybrid (*Rana esculenta*) and its sexual host ?

**HERGER Franziska, LARGIADER Carlo R., LÜRTSCHER Mathias & SCHOLL Adolf**

The *Austropotamobius pallipes* species complex in the Alpine region - phylogeographic studies using nuclear and mitochondrial markers

**HEYLAND Andreas**

Behaviour and mutual influencing of two polychaete species with different life-cycles during settlement: *Poecilochaetus serpens* E. Claparede and *Sphaerosyllis* sp. (Polychaeta: Syllidae: Exogoninae)

**HOFER Ulrich, BERSIER Louis-Félix & BORCARD Daniel**

Spatial organization of a tropical forest herpetofauna on an elevational gradient revealed by null model tests

**HÖRDEGEN Philipp**, see MORETTI Marco *et al.*

**IBANEZ Carlos**, see CASTELLA Vincent *et al.*

**ILG Christiane, CASTELLA Emmanuel & LODS-CROZET Brigitte**

Macroinvertebrate biodiversity in glacial catchment: the rule of water sources and tributaries

see also CASTELLA Emmanuel *et al.*

**JENSEN Deborah B.**

Conservation by design: the theory and practice of conservation priority setting

**JOKELA Jukka**, see RIGBY Mark C. *et al.*

**JONES Graeme R.**, see BAER Boris *et al.*

**JUGE Raphaëlle**, see OERTLI Beat *et al.*

**KALBERER Nicole & RAHIER Martine**

The cost of dispersal by flight in an alpine leaf beetle *Oreina cacaliae* (Coleoptera: Chrysomelidae)

**KELLER Laurent**, see REUTER Max *et al.*

**KELLER Michael, KOLLMANN Johannes & EDWARDS Peter J.**

Genetic introgression from distant provenances reduces fitness in local weed populations - a case study with species for ecological compensation areas

**KERY Marc**

Inferring the absence or extinction of a species from a site: a case study with three snake species

**KNADEN Markus**

Enemy recognition in the desert ant *Cataglyphis fortis*

**KNISPEL Sandra**, see CASTELLA Emmanuel *et al.*

**KÖLLIKER Mathias**

Heritability of offspring begging and its co-evolutionary potential with parental feeding behaviour

see also ROULIN Alexandre *et al.*

**KOLLMANN Johannes**, see KELLER Michael *et al.* & PFLUGSHAUPT Kaspar *et al.*

**KOLNAAR Rogier**

Effect of *Puccinia lagenophorae* on competition between *Senecio vulgaris* L. and *Capsella bursa-pastoris*

**KUENZLER Reto & BAKKER Theo C.M.**

A study of multiple female preferences in sticklebacks using computer animations

**KUSKE Stefan**

Does the mass release of the exotic egg parasitoid *Trichogramma brassicae* pose a risk to populations of endemic natural enemies ?

**LACHAVANNE Jean-Bernard**, see OERTLI Beat *et al.*

**LANDOLT Martin**, see ROY Bitty *et al.*



**LARGIADER Carlo R.**, see GANTENBEIN Benjamin *et al.* & HERGER Franziska *et al.*

**LAWTON John H.**

Biodiversity and ecosystem function

**LEUCHTMANN Adrian**, see BREM Dominik *et al.*

**LODS-CROZET Brigitte**, see CASTELLA Emmanuel *et al.* & ILG Christiane *et al.*

**LUGON-MOULIN Nicolas, BRUNNER Harald, BALLOUX François, GOUDET Jérôme & HAUSSER Jacques**

Do riverine barriers, history or introgression shape the genetic structuring of a common shrew (*Sorex araneus*) population ?

**LÜRTSCHER Mathias**, see HERGER Franziska *et al.*

**MACDONALD David**

Alien invaders

**MAIBOM Wiebke**, see MATTHIES Diethart *et al.*

**MAILE Roland**, see BAER Boris *et al.*

**MARION Thomas**, see CASTELLA Emmanuel *et al.*

**MARMONIER Pierre**, see CASTELLA Emmanuel *et al.*

**MARTIN Robert D.**, see PASTORINI Jennifer *et al.*

**MATTHIES Diethart, BRÄUER Ingo, MAIBOM Wiebke & TSCHARNTKE Teja**

Population size and risk of extinction in rare plants

**MEISTER Erhard**, see DI GIULIO Manuela *et al.* & STUDER Sibylle *et al.*

**MEYER Andrea**, see STEPHAN André *et al.*

**MICKASCH Tatjana M.**

Is there a relationship between expanding *Orconectes limosus* and decreasing *Austropotamobius pallipes* populations in Switzerland ?

**MIKOS Z. Maja & WARD Paul I.**

Cryptic female choice of male genotype in the yellow dung fly (*Scathophaga stercoraria*)

**MORETTI Marco, HÖRDEGEN Philipp, CONEDERA Marco, DUELLI Peter & EDWARDS Peter J.**

Response of invertebrates to wildfires. First results about spiders (Araneae) and ground beetles (Carabidae) in deciduous forests on the south part of the Alp (Ticino, Switzerland)

**MORGAN E. David**, see BAER Boris *et al.*

**MÜLLER Jessica**, see ANTOINE Céline *et al.* & OERTLI Beat *et al.*

**MÜLLER Jürg P.**

The reintroduction of the Bearded Vulture, *Gypaetus barbatus*, in the Alps – an example for the practical project realisation

**OERTLI Beat, AUDERSET-JOYE Dominique, JUGE Raphaëlle, CASTELLA Emmanuel, MÜLLER Jessica, ANTOINE Céline, SAAM Mirko, CAMBIN Diana & LACHAVANNE Jean-Bernard**

Biodiversity in Swiss ponds: how biotic communities respond to altitude

see also PULFER Corinne *et al.*

**OLIVIERI Isabelle**

Contribution of metapopulation-level studies to the understanding of extinction, adaptation, and speciation

**OTTMER Birgit K.**, see GERLOFF Christine U. *et al.*

**PASCHKE Melanie**

Does genetic variation matter ?

**PASINELLI Gilberto**

Effects of habitat structure on home range size and breeding success of the middle spotted woodpecker *Dendrocopos medius*

**PASTORINI Jennifer, FORSTNER Michael R. J. & MARTIN Robert D.**

Phylogenetic relationships among Lemuridae (Primates) inferred from DNA sequences

**PERRET Mathieu, SAVOLAINEN Vincent, CHAITEMS Alain & SPICHIGER Rodolphe**

Pollination systems and speciation in Sinningieae (Gesneriaceae, Angiosperm)

**PERRIN Nicolas, BALLOUX François & GOUDET Jérôme**

Breeding systems inferred from genetic structures

**PFLUGSHAUPT Kaspar & KOLLMAN Johannes**

Reproductive traits in small and isolated populations of *Prunus mahaleb*

**PFUNDER Monika**, see SCHÜRCH Stéphanie *et al.*

**PULFER Corinne, OERTLI Beat, CASTELLA Emmanuel & CAMBIN Diana**

Biodiversity of Trichoptera in Swiss ponds

**RAHIER Martine**, see HAGGSTRÖM Hakan *et al.* & KALBERER Nicole *et al.*

**REUTER Max & KELLER Laurent**

Conflict over caste determination in eusocial hymenoptera

**REYER Heinz-Ulrich**, see HELLRIEGEL Barbara *et al.*

**RIBI Georg**

Habitat alterations facilitate genetic introgression between European *Viviparus* species (Mollusca, Prosobranchia)

see also VORBURGER Christoph *et al.*

**RICHNER Heinz**, see ROULIN Alexandre *et al.*

**RIGBY Mark C. & JOKELA Jukka**

High costs of predator avoidance compromise immune defences in snails (*Lymnaea stagnalis*)

**ROMER Jann**

*Astacus leptodactylus* - a threat to native species in Lake Aegeri, Switzerland ?

**ROULIN Alexandre, KÖLLIKER Mathias & RICHNER Heinz**

Hawk-dove games among offspring of *Tyto alba*

**ROY Barbara A.**, see SCHÜRCH Stéphanie *et al.* & UTELLI Anna-Barbara *et al.*

**ROY Bitty, LANDOLT Martin, GAECHTER Fani & SCHMID Bernhard**

Relationships between biodiversity and enemy attack rates

**RUEDI Manuel**, see CASTELLA Vincent *et al.* & SALAMIN Nicolas *et al.*

**RUSTERHOLZ Hans-Peter & ERHARDT Andreas**

Influence of human land-use change on the genetic population structure of the Adonis Blue butterfly (*Lysandra bellargus* Rott)

**RUTISHAUSER Rolf**, see GALEUCHET David J. *et al.*

**RYSER Peter, ZOBEL Kristjan, EEK Liina, URBAS Pille & WAHL Stefan**

Plant characteristics which drive succession

see also BOLLENS Ursula *et al.*

**SAAM Mirko**, see OERTLI Beat *et al.*

**SALAMIN Nicolas, RUEDI Manuel & SAVOLAINEN Vincent**

Inferring complex phylogenies: which strategy to adopt ?

**SAUCY Francis**, see VIETTE Michèle *et al.*

**SAVOLAINEN Vincent**, see PERRET Mathieu *et al.* & SALAMIN Nicolas *et al.*

**SCHIEGG Karin**

- Patch size and patch connectivity: habitat relationships of saproxylic Diptera and Coleoptera

- Small but beautiful: influence of dead wood dimensions on species richness and diversity of saproxylic insects

**SCHMID Bernhard**, see FISCHER Markus *et al.* & ROY Bitty *et al.* & STEPHAN André *et al.*

**SCHMID-HEMPEL Paul**, see BAER Boris *et al.* & GERLOFF Christine U. *et al.*

**SCHNELLER Johann Jakob**, see GALEUCHET David J. *et al.*

**SCHOLL Adolf**, see GANTENBEIN Benjamin *et al.* & HERGER Franziska *et al.*

**SCHÜRCH Stéphanie, PFUNDER Monika & ROY Barbara A.**

Interactions between ants, *Euphorbia cyparissias*, and its pathogenic rust fungi

**SENN Josef**, see GUGERLI Felix *et al.*

**SIMANT Hélène**, see CASTELLA Emmanuel *et al.*

**SHYKOFF Jacqui**, see GOVERDE Marcel *et al.*

**Soliva Marco & WIDMER Alex**

Phylogenetic relationships within the orchid genus *Ophrys* based on multiple DNA sequences

**SPEIGHT Martin C. D.**, see CASTELLA Emmanuel *et al.*

**SPERISEN Christoph**, see GUGERLI Felix *et al.*

**SPICHIGER Rodolphe**, see PERRET Mathieu *et al.*

**STEPHAN André, MEYER Andrea & SCHMID Bernhard**

Plant diversity positively affects soil microbial diversity

**STUDER Sibylle, EDWARDS Peter J. & MEISTER Erhard**

Enhancing biodiversity in agricultural grasslands: plant community structure under different managements

**SUTER Werner**

A biodiversity strategy as a national nature conservation concept

**TABERLET Pierre**, see FUMAGALLI Luca *et al.*

**TENZER Isabel**, see GAUTSCHI Barbara *et al.*

**TETTAMANTI Chiara**, see VIETTE Michèle *et al.*

**THURNHEER Sylvie & ANHOLT Bradley R.**

Higher order interactions: The influence of predator-induced indirect effects on competitive ability in waterfrog larvae (*Rana esculenta* and *Rana lessonae*)

**TSCHARNTKE Teja**, see MATTHIES Diethart *et al.*

**TURLINGS Ted**, see GOUNGUENE Sandrine *et al.*

**ULLRICH Karin S. & EDWARDS Peter J.**

Enhancing biodiversity in arable land: the role of management and landscape structure

**URBAS Pille**, see RYSER Peter *et al.*

**UTELLI Anna-Barbara & ROY Barbara A.**

Altitudinal variation in nectar robbery in *Aconitum lycoctonum*

**VAN KLEUNEN Mark**, see FISCHER Markus *et al.*

**VIETTE Michèle, TETTAMANTI Chiara & SAUCY Francis**

Preference for acyanogenic white clover (*Trifolium repens*) in the vole, *Arvicola terrestris* in simple and repeated choice tests

**VORBURGER Christoph & RIBI Georg**

Mechanisms of impact of the introduced crayfish *Pacifastacus leniusculus* on the native crayfish *Austropotamobius torrentium* in Switzerland

**VOUILLAMOZ José**

The genus *Onosma* (Boraginaceae) in Switzerland: chromosome numbers, allozymic polymorphism and evolutionary history of a group of rare taxa

**WAHL Stefan**, see RYSER Peter *et al.*

**WALTHER Gian Reto**

Why palms in Switzerland ?

**WARD Paul I.**, see FREIMANN Barbara *et al.* & MIKOS Z. Maja *et al.*

**WEHNER Rüdiger**, see DIETRICH Barbara *et al.*

**WEIBEL Urs**

Nest site selection and breeding success of skylarks (*Alauda arvensis*) in an arable landscape with wild flower strips

**WEISSER Wolfgang W.**

Predator-induced morphological shift in the pea aphid

**WIDMER Alex**, see SOLIVA Marco *et al.* & ZUBER Doris *et al.*

**ZOBEL Kristjan**, see RYSER Peter *et al.*

**ZUBER Doris & WIDMER Alex**

Intraspecific phylogenetics of the European mistletoe (*Viscum album*) based on nuclear and chloroplast DNA sequences

## Abstracts

(alphabetically by first author)

### ANTOINE Céline, MÜLLER Jessica & CASTELLA Emmanuel

Laboratoire d'Ecologie et de Biologie Aquatique; Université de Genève; chemin des Clochettes 18; CH-1206 Genève; Switzerland

Assemblages of freshwater molluscs in a fringing wetland (Lake Neuchâtel, Switzerland)

Freshwater gastropod assemblages were surveyed in 9 contrasted ponds of the largest Swiss wetland (fringe of Lake Neuchâtel). The survey was carried out as a preliminary assessment of molluscan biodiversity in ponds selected along gradients of age and hydrological connections. It is intended as a basis for 1) selection of sites for monitoring of the dynamics of key species, and 2) prioritising management options aiming at biodiversity preservation/enhancement. Over 22 taxa were recorded among which *Valvata macrostoma* and *Bathymphalus contortus* (L.) are of prominent interest. Relationships between habitat types, water/sediment characteristics, molluscan diversity and species composition are discussed.

### ARNOLD Claire, GILLET François & GOBAT Jean-Michel

University of Neuchâtel; Institute of Botany; Laboratoire d'écologie végétale; rue Emile-Argand 11; CH-2007 Neuchâtel; Switzerland

Ecological knowledge and species conservation: the example of the European wild grapevine *Vitis vinifera* subsp. *sylvestris* (Gmel.) Hegi

Since the beginning of the century there has been a very marked decrease of wild grapevine in Europe, resulting in the fragmentation of its distribution area. This reduction of the populations is directly or indirectly linked to human activities and to a lack of knowledge of this subspecies. From an historical point of view, the discovery of typical wild grapevine seeds in Neolithic sites shows that this subspecies is anterior to spontaneous cultivars on the European territory. New genetical molecular technologies based on microsatellites show the presence of alleles specific to wild grapevine, which prove the originality of subsp. *sylvestris*. The ecological study of wild grapevine highlights both the necessary natural conditions for maintaining population dynamics, and the dangers which threaten it. Seedlings and young plants were observed in only 11% of the 163 studied stations. This established fact leads us to suppose that present conditions are no longer propitious to regeneration in a majority of sites whose permanence is endangered. All attempts at reintroduction in the Rhine floodplain forests have so far been unsuccessful. Precise studies of active regeneration stations should make it possible to define the optimum conditions for site revitalisation or for the successful reintroduction of wild grapevine in stations where it existed in the past.

### BAER Boris<sup>1</sup>, MAILE Roland<sup>2</sup>, SCHMID-HEMPEL Paul<sup>1</sup>, MORGAN E. David<sup>2</sup> & JONES Graeme R.<sup>2</sup>

<sup>1</sup> Experimental Ecology; ETH Zürich; Switzerland

<sup>2</sup> Keele University; Chemistry Department; Keele Staffordshire; United Kingdom

Chemistry and possible function of a mating plug in bumblebees

Previous work showed that queens of the bumblebee *Bombus terrestris* would benefit from multiple mating due to lower parasite load and higher fitness. Nevertheless, *B. terrestris* is mostly singly mated in Central Europe. One possible solution to this phenomena is that the male bumblebee does not want to share its fitness with other males and therefore prevents multiple mating by transferring a sticky plug into the queen's sexual tract. Chemical compounds in

the plug may influence the queen's behaviour, i.e. perhaps preventing her from mating again ? Using gas chromatography we identified cyclo-prolylproline and 4 different fatty acids present in the plug. We then mixed the same concentration of these compounds to create a "synthetic plug". This will enable us to test effects of these chemicals on male and queen mating behaviour.

### **BAER Boris & SCHMID-HEMPEL Paul**

Experimentelle Ökologie; ETH Zentrum NW; CH-8092 Zürich; Switzerland

#### Multiple mating: an advantage against parasites

Multiple mating by males (polyandry) and females (polygyny) is common in animal species. Whereas the advantages for males are obvious, the reasons for a female to mate several times are more difficult to understand. In social insects multiple mating by males and females reduces relatedness within colonies and thus is problematic for a kin selection explanation for the maintenance of eusociality. Nevertheless, multiple mating is common in social insects and several hypothesis have been proposed to explain this fact. One of them states that multiple mating increases genetic variability providing an advantage against parasites. We tested this hypothesis using the bumblebee *Bombus terrestris* (L.). Using artificial insemination, we were able to produce bumblebee colonies of high and low genetic diversity. These colonies were placed in the field and worker samples were collected and checked for the presence of parasites. For the two most common parasites, *Crithidia bombi* and *Nosema bombi*, we found that intensities and prevalence were lower in colonies of high genetic diversity than in colonies of low genetic diversity. Additionally, for all parasite species found, parasite load and parasite richness were significantly lower in colonies of high genetic diversity than in colonies of low genetic diversity. Finally, the fitness of colonies of low genetic diversity was lower. These results show that queens benefit from multiple mating with respect to parasitism and fitness. The fact that *B. terrestris* is singly mated in central Europe may be explained by the mating behaviour of the male, which includes mate guarding and the production of a sticky mating plug injected into the female after sperm transfer.

### **BOLLENS Ursula & RYSER Peter**

Geobotanisches Institut ETH; Zürichbergstrasse 38; CH-8044 Zürich; Switzerland

#### Nutrients and water regime: Effects on 16 wetland species

Although protected by law, Swiss wetlands suffer damage from nutrient inflow and interference to the water regime. Because species diversity is highest at a rather low level of biomass production, it is an objective of wetland management to lower site productivity. Should we focus mainly on keeping nutrients away from the surroundings or is flooding also an appropriate means to promote typical species composition ?

To test the response of various fen species to different nutrient availabilities and water levels, a factorial growth experiment was established in spring 1998. The treatments are: base-level fertilisation (0.9 mg N/individual/week, 0.06 mg P/individual/week), threefold nitrogen supply, threefold phosphorus supply; wet conditions, flood periods, and drought periods. Biomass and nutrient content were recorded in September 1998.

The first season's results show a distinct rise of biomass due to additional nitrogen fertilisation and only little effect of the phosphorus treatment. These results apply to all species whether they originate from nutrient poor or nutrient rich sites. Even under enhanced nitrogen supply there is little evidence of phosphorus limitation. All species are affected by flood. Periodic drought causes negative or positive effects on biomass production.

Conclusions: (1) Nitrogen was the growth limiting element in the experiment. The growth reducing effect of flooding was probably due to its reducing effect on N-uptake. (2) The results suggest that flooding is an appropriate means of reducing site productivity. However, the water

used for flooding should not be nitrogen rich. (3) One growing season is too short for the assessment of species-specific effects of nutrients and flooding. The experiment will be continued for another year.

### **BRASCHLER Brigitte**

Institut für Natur-, Landschafts-und Umweltschutz; Universität Basel; Johans-Vorstadt 10; CH-4056 Basel; Switzerland

#### **Influences of small-scale habitat fragmentation on ants**

In many parts of the world, human activities have greatly altered natural landscapes, converting them in mosaics of agricultural, industrial and urban patches. Habitat fragmentation is one of the most apparent consequences of human use of nature. Research has often focused on large-scale habitat fragmentation and its effects on conspicuous species groups like mammals and birds. The influence of small-scale habitat fragmentation on less conspicuous species groups, including many small invertebrates, is less studied. In my work I concentrate on the ant populations in calcareous grasslands in the Swiss Jura Mountains. I especially study influences of the fragmentation on species composition, nest dispersion and changes in interactions between colonies and between the ants and other organisms. Several aspects of foraging behaviour of ants seem to be changed in fragments compared to control plots. For example ants were more numerous at baits in fragments than at baits in control plots. Also ants preferred to forage on baits in the fragment rather than in the surrounding isolation area. Additionally, aphids, an important sugar resource of many ant species, were more abundant in fragments than in control plots. Effects on nest dispersion and species composition are less pronounced.

### **BREM Dominik & LEUCHTMANN Adrian**

Geobotanisches Institut ETH; Zollikerstrasse 107; CH-8008 Zürich; Switzerland

#### **Transmission mode of a grass endophyte with mixed strategy of reproduction**

*Epichloe sylvatica* (Ascomycota, Clavicipitaceae) is a host specific endophyte of the woodland grass *Brachypodium sylvaticum* with two alternative modes of reproduction. The predominant asexual forms are seed transmitted (vertical), whereas the sexual forms are capable of contagious transmission (horizontal) mediated by ascospores. However, transmission rate and mechanisms of infections are undetermined in this system. A transplant experiment and phenological observations were designed to estimate the rate of horizontal transmission and to explore possible routes of new infections. We observed clear coincidence of time of host flowering and availability of ascospores indicating that infection through stigmata is a possible mechanism of horizontal transmission. At sites where sexual forms of *E. sylvatica* were present 34% or 17% respectively, of the uninfected transplants became infected after two years, whereas at sites with only asexual forms all transplants remained uninfected. This suggests that contagious spread of the endophyte to established plants can occur frequently and that ascospores probably serve as inoculum. Besides the stigmata, stem or leaf tissues may provide an alternative route of entry, which can lead to new infections.

### **CASTELLA Emmanuel<sup>1</sup>, LODS-CROZET Brigitte<sup>1</sup>, CAMBIN Diana<sup>1</sup>, ILG Christiane<sup>1</sup>, KNISPEN Sandra<sup>2</sup>, MARION Thomas<sup>2</sup>, MARMONIER Pierre<sup>3</sup> & SIMANT Hélène**

<sup>1</sup> Laboratoire d'Ecologie et de Biologie Aquatique; Université de Genève; chemin des Clochettes 18; CH-1206 Genève; Switzerland

<sup>2</sup> Musée de Zoologie; Place Riponne 6; CH-1005 Lausanne; Switzerland

<sup>3</sup> GRETI; Université de Savoie; Le Bourget du Lac; France

Physical habitat and zoobenthic diversity of a glacial stream (the Mutt, Swiss Alps)

Within the framework of a European research programme for "Arctic and Alpine Stream Ecosystem Research", studies of the geomorphology, water physico-chemistry and macrobenthic communities were carried out in 1996 and 1997 on the Mutt, a glacier-fed tributary of the Rhone River (Switzerland). The objective of the programme is to test and refine Milner and Potts' model (1994) suggesting water temperature and channel stability as the main variables determining the occurrence and longitudinal succession of invertebrate taxa in glacial streams. Diversity and community composition patterns recorded on the Mutt, with sites ranging from 2600 to 1800 m a.s.l., are confronted with the model. Results evidencing high taxonomic richness for groups like Diptera Chironomidae and Trichoptera Limnephilidae are discussed, together with the current relative low level of taxonomic expertise regarding these groups in alpine ecosystems.

**CASTELLA Emmanuel<sup>1</sup>, SPEIGHT Martin C. D.<sup>2</sup> & GOELDIN DE TIEFENAU Pierre<sup>3</sup>**

<sup>1</sup> Laboratoire d'Ecologie et de Biologie Aquatique; Université de Genève; chemin des Clochettes 18; CH-1206 Genève; Switzerland

<sup>2</sup> Research Branch; National Parks and Wildlife Service; 51 St Stephens Green; Dublin 2; Ireland

<sup>3</sup> Musée de Zoologie; Place Riponne 6; CH-1005 Lausanne; Switzerland

Using species pool and digitised biological data for biodiversity assessment and conservation: a test case with Syrphidae (Diptera)

An overview is given of the use of digitised information about the European species of one group of invertebrates, the Syrphidae (Diptera), in addressing biodiversity maintenance issues. They probably represent no more than 1-2% of Europe's invertebrate biodiversity, so it cannot be claimed that they may be used as proxies for the entire European invertebrate fauna. However, they provide insights into what might be achieved if invertebrates were effectively incorporated into biodiversity maintenance work, rather than being almost universally ignored as at present - although invertebrates do represent approximately 75% of the biodiversity supported by the European continent. The species pool concept is essentially that the biota of part of a region is a sub-set of the biota of that region and so can be predicted from the regional species list, given sets of assembly or deletion rules. In the present case, examples are shown of regional and local syrphid lists, coupled with digitised information on the listed species, invoking the predictive capacity of the regional species pool. The predicted species lists generated are used for assessment of the performance of the biodiversity maintenance function at site level, and for identification of biodiversity maintenance priorities at various spatial levels. The information about Syrphid species is extracted from the "Syrph the Net" database covering some 400 syrphid species known from Atlantic parts of Europe and including spreadsheet files providing information on the habitats, microhabitats, traits, range and status of the included species.

**CASTELLA Vincent, RUEDI Manuel, EXCOFFIER Laurent & IBANEZ Carlos**

Institut de Zoologie et d'Ecologie Animale; Université de Lausanne; BB; CH-1015 Lausanne; Switzerland

Do males and females mouse-eared bats cross the Gibraltar Strait? Molecular markers say no!

Because of their role in limiting gene flow, geographic barriers like mountains or seas often coincide with large genetic discontinuities. Although the Strait of Gibraltar represents such a potential barrier for terrestrial organisms, no studies have been conducted on its impact on gene flow. Here we test this effect on a flying mammal (*Myotis myotis*) which is distributed on both sides of this Strait. Based on a sample of four populations, mtDNA haplotypes reveal a complete and ancient isolation between Northern and Southern bats. Results based on seven



microsatellite loci confirm the presence of this strong barrier to gene flow, suggesting that neither males nor females do actually cross the 15 km of the Gibraltar Strait. This conclusion is surprising since Mouse-eared bats are able to cover daily up to 25 km between roosts and foraging territories. Several alternative explanations to this surprising pattern of genetic divergence are discussed.

### **DI GIULIO Manuela, EDWARDS Peter J. & MEISTER Erhard**

Swiss Federal Research Station for Agroecology and Agriculture; Reckenholzstrasse 191; CH-8046 Zürich; Switzerland

#### **Enhancing insect diversity in agricultural grasslands: the role of management and landscape structure**

During the last two decades great efforts have been made in Switzerland to preserve and enhance biodiversity. In this context we are interested in the effects of different management systems and landscape structure on the insect diversity of agricultural grasslands.

The research area is located in the Schaffhauser Randen (Jura formation). It is an extensive forested area with a number of more or less isolated enclaves of agricultural land. Four such enclaves have been selected in order to provide areas with varying mixtures of arable and grassland habitats. In each enclave (area), meadows of two grassland management types ('medium intensive' and 'extensive') have been investigated. As an indicator group for insect diversity true bugs (Heteroptera) were chosen. Previous studies have shown that the richness of the bug fauna correlates strongly with total insect diversity.

The bug communities of extensive sites demonstrate clearly a more even rank abundance distribution compared to those of medium intensive sites. Extensive meadows have both more individuals and more species.

We used ordination techniques to assess the factors affecting the structure of bug communities. A statistical method based on Canonical Correspondence Analysis (Borcard 1992) was used to partition the variance of the species data into spatial (area) and management components. Our model explains 72.3% of the variance ( $p=0.01$ ). Management accounts for 29.7% ( $p=0.01$ ), area for 35.4% ( $p=0.01$ ) and the interaction 'management x area' for 7.2% of the species variation.

### **DIETRICH Barbara & WEHNER Rüdiger**

Institute of Zoology; University of Zürich; Winterthurerstrasse 190; CH-8057 Zürich; Switzerland

#### **Coexistence of parapatric species: how do desert ants solve this contradiction ?**

The parapatric *Cataglyphis*-species, *bicolor* and *savignyi* inhabit different parts of the lowland/highland steppes of central Tunisia and the presaharan semidesert of southern Tunisia, respectively. Due to their morphological similarity these two species have been mistaken as one single species since the beginning of this century. Within the study area both species overlap in their distributional ranges. The temporal and spatial foraging patterns of the two *Cataglyphis* species were investigated particularly in the steppe area around the oasis of El Guettar in central Tunisia. By recording the ants foraging paths we showed that *C. bicolor* exhibits significantly shorter foraging runs than *C. savignyi* with respect to both length and time: 90% of the foraging time is spent within an area of radius 14.5 m and 21.0 m, respectively (Mann-Whitney U-test:  $p = 0.014$  (length),  $p = 0.038$  (time)). This result is in accord with the outcome of geobotanical studies of the nesting sites. We were able to demonstrate that they exhibit clear-cut microhabitat differences. *C. bicolor* colonies usually occupy the more plentiful micro-habitats than *C. savignyi*. Furthermore experiments with artificial food baits showed that *C. bicolor* dominates *C. savignyi* in direct encounters. These results suggest that coexistence is maintained by the interrelationship of the two species: the dominant species drives the subordinate one out of the higher quality microhabitats.

**FINKELDEY Reiner**

Swiss Federal Institute for Forest, Snow and Landscape Research (WSL); Zürcherstrasse 111; CH-8903 Birmensdorf; Switzerland

**Molecular markers and the conservation of forest resources - is there an impact ?**

During the last decade a rapidly increasing number of molecular genetic markers was successfully applied to forest trees. The urgent need to conserve forest genetic resources has often motivated this research. However, the practical impact of most molecular genetic studies is negligible. At least three main reasons account for this situation: first, research has concentrated on a few widespread, common tree taxa of the temperate and boreal zone (in Europe mainly *Picea*, *Pinus* and *Quercus* species), although the need for conservation measures is most urgent for endemic, rare species of the tropics. Second, research focused on an investigation of spatial patterns of genetic variation at marker loci without straightforward implications for patterns of adaptive variation. Third, new molecular techniques have shifted research priorities from problem-orientation towards method-orientation. Researchers tend to concentrate on the development and validation of new marker types rather than on the application of existing tools to urgent conservation problems. Biochemical and molecular markers have the potential to contribute significantly to the conservation of forest resources if they are used to investigate key processes in endangered forest ecosystems. This implies their application in a population genetic context, their combination with other investigations including ecological field observations and quantitative genetic experiments, and a focus on both spatial and temporal dynamics of genetic structures. A recently published study on the reproduction and gene flow of tropical figs (*Ficus* spp.) based on allozyme markers illustrates the usefulness of gene markers in this regard.

**FISCHER Markus, VAN KLEUNEN Mark & SCHMID Bernhard**

Institut für Umweltwissenschaften; Universität Zürich; Winterthurerstrasse 190; CH-8057 Zürich; Switzerland

**Relations among population size, genetic variation, and plant performance: the example of *Ranunculus reptans***

Firstly, we studied selectively neutral RAPD-variation in samples representing comparable areas of 17 populations (3 at Lake Como, 14 at Lake Constance) of the clonal *Ranunculus reptans*, a rare lake-shore plant. Variation among populations ( $p < 0.001$ ) corresponds to a low gene flow of  $Nm = 0.84$ . Molecular variance was smaller in small populations covering  $< 100 \text{ m}^2$  area than in larger ones ( $p < 0.03$ ), indicating genetic drift. Secondly, we grew vegetative offspring of 104 genotypes from the 14 Lake Constance populations with and without competition by the grass *Agrostis stolonifera* in a plant room and measured the number of nodes (rooted, flowering, and total) produced per planted rosette. Plants from larger populations produced more nodes than plants from smaller populations (total  $p < 0.03$ ; rooted  $p < 0.1$ ; flowering  $p < 0.01$ ), whereas positive correlations with molecular variance were not statistically significant. Plasticity (mean without competition minus mean with competition) of node numbers was larger for plants from larger populations (significant for total number of nodes) and for plants from populations with higher molecular variance (significant for number of rooted nodes). Non-significant correlations between broad-sense heritabilities and population size respective molecular variance were positive for the numbers of nodes and negative for plasticities therein. Numbers of nodes and plasticity therein were negatively correlated with the corresponding heritabilities. Because we grew plants in controlled environments our study indicates a genetic basis of observed patterns. Because differences among populations were more closely related to population size than to molecular variance they rather indicate effects of selection than of genetic erosion. Directed selection may also explain observed negative correlations between performance measures and corresponding heritabilities. Our study supports the notion that genetics matter for plant conservation.

**FREIMANN Barbara & WARD Paul I.**

Zoological Museum of the University of Zürich; Winterthurerstrasse 190; CH-8057 Zürich; Switzerland

Male seminal products influence female sperm storage muscles in *Scathophaga stercoraria*

The Yellow dungfly *Scathophaga stercoraria* (L.) is frequently used as a model organism to examine questions about reproductive strategies. In this study we examine the influence of male seminal products on the muscles of the female sperm storage organs, the spermathecae. There are normally three spermathecae, arranged as a singlet and a doublet, which are connected to the bursa copulatrix by long ducts. Isolated female reproductive tracts were treated with different male extracts: from testes, ductus seminalis or as a control, Ringer. It was shown that male testes extracts increase the contraction rate of female spermathecal muscles. There may also be differences between the reactions of singlet and doublets. It is suggested that this mechanism helps to transport sperm into the female spermathecae, as sperm cannot move extensively on their own. The control of muscles responsible for sperm uptake is therefore a "hot spot" in the conflict of interests between male and female in this polygamous fly.

**FREYMOND Hervé & GALLAND Nicole**

Institute of Ecology; University of Lausanne; CH-1015 Lausanne; Switzerland

Genetic diversity and conservation of *Saxifraga hirculus*

*Saxifraga hirculus* L. is a tetraploid arctic-boreal plant species; it has a wide circumpolar distribution, whereas its distribution outside Polar regions is highly fragmented. In Switzerland, *Saxifraga hirculus* was known to occur in at least 25 localities but now only occurs in one locality (Col du Marchairuz, VD, the southernmost European population of this species). As a consequence of such fragmented distribution and of restricted gene flow, genetic drift and inbreeding may occur in the relic populations. Thus, in a conservation perspective, we have addressed three major questions: 1) What is the level of genetic diversity within and among populations ? 2) Is there a spatial genetic structure within populations, and if so, what is the size of the breeding units ? 3) How critical is the vegetative reproduction versus sexual one ? For this purpose, a survey of allozymes/AFLPs diversity of six populations (from Switzerland, Denmark and Iceland) is being undertaken. Methodology and sampling scheme are presented, with the advantages and limits of allozymes and AFLPs. The results of this study will help in designing conservation plans in the future.

**FUMAGALLI Luca & TABERLET Pierre**

Laboratoire de Biologie de la Conservation; Institut d'Ecologie; Bâtiment de Biologie; Université de Lausanne; CH-1015 Lausanne; Switzerland & Laboratoire de Biologie des Populations d'Altitude; CNRS UMR 5553; Université Joseph Fourier; BP 53; F-38041 Grenoble Cedex 9; France

Genetic affiliation of historical wolves from Switzerland

Human persecution and forest clearance has led to the eradication of wolf *Canis lupus* populations in the Alps in general and in Switzerland in particular before the end of the 19th century, even if few isolated individuals of unknown origin have been killed during the 20th century. The species started to recolonize this region from the Italian population in the early 1990s and this process is still going on. We have sequenced a portion of the mitochondrial DNA control region from three historical samples: one individual from a Middle Age site, and two individuals killed in 1947 and 1954, respectively. The mitochondrial data can be useful to characterise whether the population presently colonising the Alps corresponds to the historical lineage disappeared from Switzerland. The analysis reveals that: (1) the DNA sequence from

the Middle Age sample is closely related to a wolf mitochondrial lineage found in Central Europe; (2) the two individuals killed in Switzerland during this century show a mtDNA haplotype typical of North American wolf populations. Conservation implications of these results are discussed.

### **GALEUCHET David J., RUTISHAUSER Rolf & SCHNELLER Johann Jakob**

Institute of Systematic Botany; University of Zurich; Zollikerstrasse 107; CH-8008 Zürich; Switzerland

*Typha minima* - formerly common, now endangered. Genetic variability and relationship between fragmented and ex situ populations

In Europe *Typha minima*, a pioneer plant in alluvial zones of alpine rivers, has become endangered. During the last decades the number of populations strongly decreased due to loss of natural habitats. We asked the following questions: Which consequences has fragmentation on the genetic variability of *Typha minima*? What are the consequences for the conservation? Our results showed that in spite of strong fragmentation no genetic drift was detected along the river Rhine. This might be due to the fact that fragmentation of populations took place only recently and/or to clonal growth of the species. Gene flow may be still possible by water transport (seeds) downstream. However, the distance between populations seems to be too far for effective wind dispersal (pollen, seed). To preserve *T. minima* from extinction and to rebuild a functional metapopulation along the river Rhine it is necessary to reintroduce plants from ex situ populations. A reintroduction into the Rhone valley is questionable, because the ex situ populations in the botanical gardens of Fribourg and Geneva are not known.

### **GANTENBEIN Benjamin, LARGIADER Carlo R. & SCHOLL Adolf**

Institute of Zoology; Division of Population Biology; University of Bern; Baltzerstrasse 3; CH-3012 Bern; Switzerland

Nuclear and mitochondrial gene variation among populations of *Buthus occitanus* (Amoreux, 1789) across the Strait of Gibraltar

We analyzed population samples of *Buthus occitanus* (Amoreux, 1789) (Scorpiones: Buthidae) across the Strait of Gibraltar using allozyme electrophoresis (15 loci scored) and sequencing a 460 bp fragment of the 16S rRNA mitochondrial gene. The samples were collected from three sites in Spain and France (ssp. *occitanus*), eleven sites in Morocco (ssp. *occitanus*, ssp. *mardochei* and ssp. *paris*) and one site in Tunisia (ssp. *tunetanus*). Also, *B. atlantis* from five sites along the Atlantic coast of Morocco were included, this taxon was alternatively treated as a subspecies of *B. occitanus*. A sample of *Androctonus mauretanicus* (Pocock, 1902) from Morocco and a sample of *Androctonus crassicauda* (Olivier, 1807) from Turkey were included as outgroups in the allozyme analysis. *Centruroides exilicauda* (Wood, 1863) from Baja California was the outgroup for DNA sequence analysis. Generally, the observed genetic variability of allozymes was low within populations. The UPGMA phenogram, based on Neis D (1972), shows a low genetic differentiation among all *Buthus* samples from Morocco (including *B. atlantis*). *B. o. occitanus* from Europe and *B. o. tunetanus*, however, clearly branch off at a high genetic distance. In contrast to the allozymes, the mtDNA data revealed more differentiation among the Moroccan samples, showing several lineages. The divergence among these lineages is about the same as between populations separated by the Strait of Gibraltar (approximately 12% sequence divergence).

### **GAUTSCHI Barbara & TENZER Isabel**

Institut für Umweltwissenschaften; Universität Zürich-Irchel; Winterthurerstrasse 190; CH-8057 Zürich; Switzerland & Institute of Plant Sciences: Pathology Group; Universitätstrasse 2; ETH Zentrum; CH-8092 Zürich; Switzerland

### Development of microsatellite markers for the Bearded Vulture (*Gypaetus barbatus*) and their application to the reintroduction project

We describe the construction of a genomic library of *G. barbatus* enriched for the simple sequence repeats (CA)<sub>n</sub> and (GA)<sub>n</sub>, respectively. We found 29 different microsatellite repeats in 62 positive clones sequenced. So far, unique primer pairs for 16 of these 29 loci could be designed. Eleven primer pairs amplified in a locus specific manner. We describe the characteristics of these microsatellite markers and present preliminary results of polymorphism. The use of these newly developed microsatellite markers for the reintroduction project will be discussed.

#### **GEBHARDT-HENRICH SABINE**

Ethologische Station Hasli; Universität Bern; Wohlenschtrasse 50a; CH-3032 Hinterkappelen; Switzerland

### Reproductive success was predicted by body mass loss in female great tits (*Parus major*)

Body mass changes between incubation and when nestlings were 14 days old were measured in a great tit population breeding in artificial nestboxes. Half of the pairs were experimentally fed from nestbuilding until the hatching day of their young. Females lost 1.82 g (STD: 1.15, N = 67) between incubation and when their nestlings were 14 days old. Mass loss was not affected by experimental feeding. In control (unfed) females fledgling mass was significantly negatively correlated with body mass loss of the females. Under additional feeding this relationship tended to disappear. Fledgling mass is a predictor of fledgling survival in tit species and thus a measure of reproductive success. Fledgling number was not correlated with loss of body mass. Therefore, females losing less body mass during breeding had a higher current reproductive success than females with a greater loss of body mass.

#### **GERLOFF Christine U., OTTMER Birgit K. & SCHMID-HEMPEL Paul**

Experimental Ecology; ETH-Zentrum NW; CH-8092 Zürich; Switzerland

### Inbreeding in bumble bees

In small and isolated populations low levels of genetic variation may increase the likelihood of inbreeding, leading to inbreeding depression. In addition to more general negative effects, inbreeding in social hymenoptera leads to the production of diploid males. These males develop from eggs that should have produced workers or young queens but instead develop into diploid males because they are homozygous at the sex determining locus. The production of diploid males is very costly for the colony because it decreases the work force by 50%, and furthermore, the diploid males do not sire viable colonies. We studied the effect of inbreeding on the performance of colonies of the bumble bee *Bombus terrestris* (L.). We compared colonies of queens mated to their brother to those mated to an unrelated male (33 inbred and 44 outbred colonies out of 16 maternal families). We scored the number of workers and sexuals produced and calculated the caloric investment into sexuals to estimate fitness at the colony level. At the level of the individual we measured the efficiency of immune defences. The results show that inbreeding has no consistent negative effect but that the effect depends on the genetic background of the family and the colony. Diploid males had significantly lower immune defences than haploid males. Thus, when assessing the effects of inbreeding in a population, its genetic structure has to be considered.

#### **GOUDET Jérôme**

Institut de Zoologie et d'Ecologie Animale; Bâtiment de Biologie; Université de Lausanne; CH-1015 Lausanne; Switzerland

### A population genetics view of multivariate statistical methods

While multivariate statistics are appealing to the population geneticist, they suffer from two drawbacks. The first is the lack of correspondence between inertia and a genetic parameter. The second is the absence of good testing procedure. Here I identify the relation between inertia and Fst, and suggest a test for both total inertia and the inertia of the different axes. The analyses are applied to both simulated and real data sets. Advantages and limits of multivariate methods are discussed.

### GOINGUENE Sandrine, DEGEN Thomas & TURLINGS Ted

Université de Neuchâtel; Institut de Zoologie; Laboratoire d'Ecologie Animale et d'Entomologie; rue Emile-Argand 11; CH-2007 Neuchâtel; Switzerland

#### How parasitoids of caterpillars find suitable hosts ?

Many parasitoids that attack phytophagous insects make use of plant odours to locate the habitat of their hosts. These odours are specifically emitted by a plant after it has been damaged by a herbivore, and not after mechanical damage. The odour emissions occur systemically throughout the plant. Factors in the oral secretion of the herbivores are the main elicitors of the plants' reaction. One such elicitor, volicitin, was recently isolated and identified. The induced plant odours are useful cues for the parasitoids and indicate the presence of a potential host. Studies on these volatile plant signals have been conducted most extensively with maize plants and have led to the exact identification of the blend of compounds (mainly terpenoids) that is emitted after caterpillar attack. Our recent studies show that plants of a single maize variety consistently emit similar odour blends, but there can be considerable variation among different maize genotypes. This variation is also observed in the emissions of wild relatives of maize. We discuss these results in the context of the reliability of plant-induced signals as cues that allow parasitic wasps to find suitable hosts.

### GOVERDE Marcel, BAZIN Alain, SHYKOFF Jacqui & ERHARDT Andreas

Institut für Natur-, Landschafts- und Umweltschutz; St. Johannis-Vorstadt 10; CH-4056 Basel; Switzerland

#### Influence of leaf chemistry of *Lotus corniculatus* (Fabaceae) on larval development of *Polyommatus icarus* (Lepidoptera, Lycaenidae): effects of elevated CO<sub>2</sub> and plant genotype

1) Four *Lotus corniculatus* genotypes differing in their cyanoglycoside and condensed tannin concentrations were grown in either low (350 ppm) or high (700 ppm) atmospheric CO<sub>2</sub> environments. Larval performance, consumption and conversion efficiency of *Polyommatus icarus* feeding on this plant material was measured. 2) Plants grown under elevated CO<sub>2</sub> contained less cyanoglycosides, more condensed tannins and more starch than control plants. However, water content, nitrogen and protein as well as the nitrogen content in relation to carbon concentration did not differ between CO<sub>2</sub> treatments. 3) The four genotypes differed significantly in condensed tannins, cyanoglucoside, leaf water and leaf nitrogen but no genotype x CO<sub>2</sub> interaction was detected, except for total phenolics and condensed tannins in which two plant genotypes showed stronger increases under elevated CO<sub>2</sub> than the other two. 4) Larvae of *P. icarus* consumed more plant material and used and converted it more efficiently from plants grown at high atmospheric CO<sub>2</sub>. 5) Larvae developed significantly faster and were significantly heavier when fed plant material grown under elevated CO<sub>2</sub>. The observed difference in weight disappeared in the pupal and adult stages. However, lipid concentration of adults from the elevated CO<sub>2</sub> treatment was marginally significantly higher than of controls. 6) We conclude that the higher carbohydrate content of *L. corniculatus* plants grown at elevated CO<sub>2</sub> renders leaves more suitable and better digestible to *P. icarus*. Furthermore, differences in allelochemicals might influence the palatability of *L. corniculatus* leaves for this specialist on Fabaceae.

**GUGERLI Felix, SPERISEN Christoph, BÜCHLER Urs & SENN Josef**

Swiss Federal Institute for Forest, Snow and Landscape Research; Zürcherstrasse 111; CH-8903 Birmensdorf; Switzerland

Genetic diversity in tree species of subalpine forests: a case study of Norway spruce (*Picea abies*)

From a human perspective, one of the predominant tasks of forests in mountainous areas is to protect against natural hazards. Stability of mountain forest stands, however, is increasingly threatened by air pollution, cease of management, lack of regeneration due to overabundant ungulates, and novel environmental conditions because of climate change. The project 'Biodiversity in Alpine Forest Ecosystems: Analysis, Protection and Management', funded by the European Union, addresses the genetic diversity of carrier species in Alpine forest ecosystems. The overall objective of the project is to create a common data pool which will help to better understand the function and dynamics of forest ecosystems and to transfer results into practice. At 14 locations across the Alps, each consisting of three elevational levels, populations of adult and juvenile forest tree species are sampled. The target species are *Abies alba*, *Larix decidua*, *Picea abies*, *Pinus cembra*, and *P. nugo*. Nuclear (isoenzymes, microsatellites) as well as plastid markers (chloroplast microsatellites, mitochondrial tandem repeats) are investigated by respective expert groups. Our group so far screened 25 populations of Norway spruce (*Picea abies* (L.) Karst.) for a length polymorphism in the mitochondrial fragment of a *nad1* intron. We found a decrease of within-population variation from eastern to western populations, which we relate to a serious bottleneck during re-colonization of the Alpine range by Norway spruce.

**GÜSEWELL Sabine**

Geobotanisches Institut ETH; Gladbachstrasse 114; CH-8044 Zürich; Switzerland

Does the public support restoration measures in fen meadows invaded by common reed ?

Public support is indispensable to the long-term success of measures for nature conservation and restoration. Such measures are more likely to be approved if their aims are understandable and if they are considered useful by the general public; aesthetical aspects might be particularly important in strongly frequented areas. This study investigated whether the invasion of fen meadows by common reed (*Phragmites australis*) is perceived as a degradation by the general public and whether measures to restore lower, more open vegetation types are supported. Qualitative interviews were carried out in the field with visitors of a wetland nature reserve (Robenhäuser Ried/ZH); moreover, students of various disciplines answered a questionnaire based on colour photographs. The field survey revealed no general preference for sites with either a high or a low abundance of *Phragmites*. In the questionnaire survey, the tendency to prefer fen meadows with a low abundance of *P. australis* differed among disciplines and increased with the (presumable) knowledge of students about nature conservation. Likewise, the acceptance of restoration measures appeared to mainly depend on ecological knowledge. Both surveys suggested that people reject restoration measures (regardless of their aesthetical evaluation) if they can not conceive (a) that fen meadows are semi-natural areas needing management, (b) that the spread of *P. australis* might be a consequence of human impacts and (c) that changes in management can be necessary to maintain a status quo. More information about these points would probably enhance public support to nature conservation and restoration.

**HAGGSTRÖM Hakan<sup>1</sup>, RAHIER Martine<sup>1</sup> & HARTMANN Thomas<sup>2</sup>**

<sup>1</sup>Laboratoire d'Ecologie Animale et Entomologie; Institut de Zoologie; Université de Neuchâtel; rue Emile-Argand 11; CH-2007 Neuchâtel, Switzerland

<sup>2</sup>Institut für Pharmazeutische Biologie der Technischen Universität Braunschweig; D-38106 Braunschweig; Germany

### Deterrent effect of pyrrolizidine alkaloids and detoxification by a generalist predator (*Mitopus morio*)

Several leaf beetles in the genus *Oreina* sequester pyrrolizidine alkaloid N-oxides (PAs) from their host plants (e.g. *Adenostyles* spp., Asteraceae). We studied the efficiency of these compounds as defence against a harvestman (*Mitopus morio*, Phalangidae) which is common in habitats where *Oreina* spp. occur. *M. morio* was observed to feed on larvae of *O. speciosissima* and *O. cacaliae* both in the field and in a laboratory experiment. Two populations of *M. morio* were compared with respect to the deterrent effect of PAs and the efficiency of detoxification. One of the populations comes from a site dominated by *Adenostyles alliariae*. These individuals are likely to have come into contact with prey containing PAs. The other population comes from a site where *Adenostyles* spp. are absent and is therefore likely to have little experience of PAs. For the test of deterrence, the individuals were offered artificial food (minced meat) containing the PA senecionine N-oxide in different concentrations. The efficiency of PA detoxification was studied in a tracer feeding experiment. The two populations differed in both behaviour and detoxification ability. Individuals from the population lacking *Adenostyles* plants were more deterred by the alkaloid compared to those from the other site. The metabolic treatment of PAs differed between the populations, but both populations had efficient ways to eliminate PAs and did not sequester these compounds for their own defence. We suggest that the efficiency of PAs as defence for sequestering herbivores may differ between populations.

#### HEEB Philipp

Centre for Behaviour and Evolution; Hasli Ethol. Station; University of Bern; CH-3032 Hinterkappelen; Switzerland

### Within-pair copulation frequency predicts female reproductive performance in tree sparrows, *Passer montanus*

Female birds can solicit and accept copulations from males and are thus able to control their copulation frequency. Engaging in copulations is expected to be costly since copulations take up time and can increase the risks of predation and pathogen transmission. Given these costs, the high frequency of within-pair copulations shown by many monogamous birds remains puzzling. A number of hypotheses have been proposed to explain the benefits that female birds obtain from frequent copulations with their male. These non-exclusive hypotheses predict that high within-pair copulation frequencies should be positively associated with components of female reproductive performance. In agreement with this prediction results from a tree sparrows population show that within-pair copulation frequency was positively correlated with the number of eggs laid and the number of young raised. The results suggest that, in tree sparrows, within-pair copulation frequency can be considered as an early expression of the pairs' reproductive ability. The possibility that within-pair copulation frequency could function as a signal for assessment of phenotypic quality by both males and females is discussed.

#### HELLRIEGEL Barbara<sup>1</sup> & REYER Heinz-Ulrich<sup>2</sup>

<sup>1</sup> Zoological Museum; Winterthurerstrasse 190; CH-8057 Zürich; Switzerland

<sup>2</sup> Zoological Institute; University of Zurich; Winterthurerstrasse 190; CH-8057 Zürich; Switzerland

### Which factors influence the composition of mixed populations of a hemiclinal hybrid (*Rana esculenta*) and its sexual host ?

Hemiclinal hybrids combine advantages of sexual and asexual reproduction, but their need for backcrossing tightly couples their population dynamics with that of their sexual hosts. Two discrete-time models are constructed to identify important factors influencing the composition and dynamics of the resulting mixed populations. Hybridogenetic waterfrogs serve as an



example. The results can explain the remarkable stability over time of observed species ratios within hybridogenetic populations, even when population sizes fluctuate. They also make suggestions why species ratios vary so widely between populations: the precondition is that either one or several of the four factors mate choice, relative fecundities, (larval) competitive abilities, dispersal and their interactions differ among localities. While differences in fecundity influence species coexistence, larval superiority seems to be more important for the hybrids spread in mixed populations; but differences between host and hybrid are not necessary for their coexistence. Dispersal affects the species composition mainly in the habitat where host and hybrid are competitively equal, but ecological and reproductive dispersal have opposing effects. These results suggest interesting consequences for other tightly coupled systems.

### **HERGER Franziska, LARGIADER Carlo R., LÜRSCHE Mathias & SCHOLL Adolf**

Division of Population Biology; Institute of Zoology; University of Bern; Baltzerstrasse 3; CH-3012 Bern; Switzerland

#### The *Austropotamobius pallipes* species complex in the Alpine region - phylogeographic studies using nuclear and mitochondrial markers

In a joint analysis of nuclear (allozyme) and mitochondrial markers (sequence and RFLP analysis) five genetically distinct groups of the *Austropotamobius pallipes* (Lereboullet 1858) species complex were detected in the Alpine region. The geographic distribution of these evolutionary lineages coincided largely with several taxa (*A. p. pallipes*, *A. berndhauseri*, *A. p. italicus*) defined on the basis of morphological characters. A low level of genetic variability was found within these lineages. In some cases, the combination of the two marker classes allowed to assess the natural or artificial origin of populations. The interlocking distribution of the five evolutionary lineages indicated that conservation efforts must aim at the level of local populations.

### **HEYLAND Andreas**

Zoological Museum; University of Zurich; Winterthurerstrasse 190; CH-8057 Zürich; Switzerland

#### Behaviour and mutual influencing of two polychaete species with different life-cycles during settlement: *Poecilochaetus serpens* E. Claparede and *Sphaerosyllis* sp. (Polychaeta: Syllidae: Exogoninae)

The influence of a small interstitial polychaete (*Sphaerosyllis* sp.) on the settlement behaviour of a polychaete with a benthoplanktonic life-cycle (*P. serpens*) was examined in a series of laboratory experiments. *Sphaerosyllis* sp. was found exclusively in the first cm of the sediment and was among the most abundant species at this site, with an average of around 11,000 animals per m<sup>2</sup>. From direct observations of the settlement process of *P. serpens* with a digital camera-system it was found that *Sphaerosyllis* sp. disturbed the settlement behaviour of *P. serpens* planktonic larvae that were in an advanced developmental stage. However this influence was not strong enough to prevent *P. serpens* larvae from settling. *P. serpens* settled immediately on the sediment but a decision to leave the substratum could be made after the animal was partially burrowed. Possible reasons and consequences of this behaviour are discussed. The nearest neighbour distances between settling planktonic *P. serpens* larvae were measured under laboratory conditions. No avoidance behaviour was observed between these larvae, which might explain the patchy distribution of *P. serpens* in the field.

### **HOFER Ulrich<sup>1</sup>, BERSIER Louis-Félix<sup>2</sup> & BORCARD Daniel<sup>3</sup>**

<sup>1</sup> Department of Vertebrates; Natural History Museum; Bernastrasse 15; CH-3005 Bern; Switzerland

<sup>2</sup> Zoological Institute; University of Neuchâtel; rue Emile-Argand 11; CH-2007 Neuchâtel; Switzerland

<sup>3</sup> Département de sciences biologiques; Université de Montréal; C.P. 6128; Montréal, Québec H3C 3J7; Canada

### Spatial organization of a tropical forest herpetofauna on an elevational gradient revealed by null model tests

Five null model tests were applied to the herpetofaunal assemblage on the western slope of Mount Kupe, Cameroon. Based on the pattern of species range boundaries and abundances along the primary forest elevational gradient, ranging from 900 to 2,000 m, the relative importance of interspecific competition and ecotones in structuring the assemblage was assessed. Tests were run for 1) all species, 2) amphibians, 3) reptiles, 4) amphibians dependent on streams for reproduction, and 5) amphibians that don't use streams for reproduction. For three null models, the observed patterns do not differ from random expectations. The results indicate that there are very few species whose gradient distributions may be limited by interspecific competition between congeners. Significant discontinuities in abundance patterns and range boundary dispersion revealed zonations in all subsets analyzed, but neither indicate distinct species groups with sharp exclusion boundaries nor a strong response to vegetational ecotones. Physical factors varying in parallel with the gradient and specific habitat components, particularly waterbodies suitable as amphibian breeding sites, are suggested to be the dominant factors in limiting gradient distributions of amphibians and reptiles on Mount Kupe. The zonations revealed suggest a pattern of three spatially non-exclusive species groups: physical factors separate distinct lowland and montane species limited by physiological constraints and produce the faunal discontinuities in the lower submontane forest around 1,300 m; this boundary is encompassed by the range of a group of anuran species, whose distributions on the gradient are centred at intermediate elevation, and appear to be limited by specific habitat requirements. The response to predominantly abiotic factors suggests a basic difference to endotherms, where biotic factors seem to be of major importance in limiting elevational distributions.

### ILG Christiane, CASTELLA Emmanuel & LODS-CROZET Brigitte

Laboratoire d'Ecologie et de Biologie Aquatique; Université de Genève; chemin des Clochettes 18; CH-1206 Genève; Switzerland

### Macroinvertebrate biodiversity in glacial catchment: the rule of water sources and tributaries

Alpine streams remain relatively understudied, regarded as sheltering poor zoobenthic communities, mainly made up of *Diamasa* (Diptera, Chironomidae). If this is true for glacial rivers, at the snout of the glacier, it is not valid for rhithral or krenal segments, snowmelt- or ground-water-fed, that allow relatively diverse communities to develop. The study presented here, illustrates the case of the Mutt (Valais, Swiss Alps). The main channel is typically kryal, fed by glacial meltwater. Its tributaries are glacial outlets or krenal stream ecosystems. These ground-water fed streams show a broad scale of physico-chemical characteristics depending on altitude, geological substratum or season. There is a very strong correlation between environmental variables (temperature, conductivity, turbidity and discharge) and the composition of the macroinvertebrate communities. In the glacial brooks harsh conditions prevail: low water temperature, high turbidity, large diel discharge fluctuations. Never more than 5 taxa, essentially chironomids, were found in each station. On the other hand, the krenal tributaries are inhabited by highly diversified macroinvertebrate communities (up to 20 taxa at one station). These species, most of them belonging to various families of Plecoptera, Ephemeroptera, Trichoptera, Diptera, prevail in rheocrene habitats, characterised by high physico-chemical stability. The habitat heterogeneity, generated by the different water origins, favours the coexistence in a rather small catchment area of diversified macroinvertebrate communities, and plays therefore an important part in the biodiversity of the Mutt basin.

**JENSEN Deborah B.**

Conservation Science Division; The Nature Conservancy; 1815 N. Lynn Street; Arlington, VA 22209; USA

### Conservation by design: the theory and practice of conservation priority setting

One key challenge in biodiversity conservation is deciding what actions must be taken today, and which can be put off until tomorrow. Not all species nor all places are equally at risk. Over the past two decades conservation biologists have developed practical but rigorous methods for setting priorities for species, sites and even countries or regions. While most agree that biodiversity value and threat are important criteria for priority setting, disagreements on methods of selecting conservation sites abound. This lecture will review the main approaches for conservation priority setting and argue for the systematic design of reserve networks. Current examples of efforts to design reserve networks will be taken from The Nature Conservancy's work in North and South America.

**KALBERER Nicole & RAHIER Martine**

Institut de Zoologie; Université de Neuchâtel; rue Emile-Argand 11; CH-2007 Neuchâtel; Switzerland

### The cost of dispersal by flight in an alpine leaf beetle *Oreina cacaliae* (Coleoptera: Chrysomelidae)

One part of the population of *Oreina cacaliae* leaves the host plant patches in autumn and flies to overwintering places away from the host plant. The other part of the population overwinters next to the host plant and does not fly. Flying females emerge earlier in the season and start reproducing earlier than their nonflying conspecifics. In 1997 the flyers took advantage of an early start and the fecundity was not significantly reduced compared to the nonflyers although the flyers died earlier. Due to the extremely high mortality in the flyer group in 1998 fecundity was significantly lower compared to the nonflyers. The cost of dispersal by flight seems to be the higher risk of mortality compared to beetles that overwinter next to the host plant and do not engage in flight.

**KELLER Michael, KOLLMANN Johannes & EDWARDS Peter J.**

Geobotanisches Institut; ETH; Zürichbergstrasse 38; CH-8044 Zürich; Switzerland

### Genetic introgression from distant provenances reduces fitness in local weed populations - a case study with species for ecological compensation areas

Various seed mixtures have been suggested for ecological compensation areas in intensively used farmland. Seed mixtures which contain foreign seed provenances may reduce fitness in local populations due to genetic introgression. 2) This hypothesis was tested with the weed species *Agrostemma githago*, *Papaver rhoeas* and *Silene alba*. Hybrids (F2 backcrosses) between local Swiss plants and English, French, German and Hungarian provenances (plus one French *Papaver* and one US source in *Silene*) were tested in the field for effects on fecundity. Aboveground biomass after one growing season was taken as a measure for fitness under natural environmental conditions. In some cases, survivorship in the field assay and seed mass were determined. The results were compared with the parents, with the F1 and with crossings among other Swiss provenances. 3) Negative outbreeding effects on fecundity were found in all four hybrids of *Papaver* and in the F2 of *Agrostemma* with introgressions by the German provenance, but not in *Silene*. Mortality was slightly higher in the F1 of *Papaver*, and even more in the F2, whereas it was unaffected in the *Silene* hybrids. Seed mass of *Agrostemma* and *Silene* decreased in the F2 compared with the F1. 4) The results are discussed with respect to the use of foreign provenances on agricultural compensation areas and in the context of reinforcement of endangered plant populations. The relevance of the measured fitness components, and long-term effects of genetic introgressions are addressed as well.

**KERY Marc**

Institut für Umweltnaturwissenschaften; Uni Zürich; Winterthurerstrasse 190; CH-8057 Zürich; Switzerland

**Inferring the absence or extinction of a species from a site: a case study with three snake species**

Many animal species are difficult to see and even during visits to known occupied sites no specimen may be detected. For such species local extinction or absence from a site may be difficult to ascertain. However, if we know with what probability a species is detected at any one visit to an occupied site, the number of times that a site has to be visited unsuccessfully, before it can be presumed unoccupied, can be calculated. The probability of detection can be estimated from visits to sites known to be occupied. From 1994 to 1997 I studied the probability of detection in three snake species, *Vipera aspis*, *Coronella austriaca* and *Natrix natrix* at 88 sites in the Jura mountains. In all species, probability of detection was higher in larger populations. There was no effect of the type of habitat nor of the size of a site. Overall, there was a 38%, 13%, and 21% chance per visit to see at least one specimen of *V. aspis*, *C. austriaca* and *N. natrix*, respectively. This translates into 7, 23 and 13 unsuccessful visits, respectively, that are necessary before a site can be assumed unoccupied. Sites whose occupancy status is unknown are most likely occupied by small populations. For them, a minimum of 15, 28, and 35 visits are necessary in *V. aspis*, *C. austriaca* and *N. natrix*, respectively. Hence, to infer the absence of these species, a much larger search effort than usually applied may be necessary. Furthermore, some of the species may be more widespread than hitherto thought.

**KNADEN Markus**

Zoologisches Institut; Universität; Winterthurerstrasse 190; CH-8057 Zürich; Switzerland

**Enemy recognition in the desert ant *Cataglyphis fortis***

Twenty ants of colony A were given into individual encounters with each 10 ants of colony B and C. A mean aggression level was calculated. After these fights 10 ants of colony C were put into colony A where they were killed immediately. In the next day the individual encounters between ants of colony A and B as well as C were repeated. There was an increased aggression level of colony A against C, but not against B. *Cataglyphis* ants seem to be able to recognize ants which have been intruders in the past.

**KÖLLIKER Mathias**

Zoology Department; University of Bern; CH-3032 Hinterkappelen; Switzerland

**Heritability of offspring begging and its co-evolutionary potential with parental feeding behaviour**

Models of parent-offspring conflict predict that the differing evolutionary interests of genes expressed in parents and their dependent offspring lead to an arms race between offspring begging and parental feeding behaviour. In theory, the evolutionary stable resolution varies depending on 1) mating system, 2) offspring relatedness, 3) fitness cost of begging to offspring and 4) fitness cost of parental effort to parents. In the great tit (*Parus major*), male and female parents feed their young to variable relative amounts, offspring relatedness varies among families due to extra-pair paternity and parents seem to make individual trade-off decisions between current and future reproduction. Such within-population variation may lead to the maintenance of a range of conflict resolutions, rather than one single outcome. We investigated this hypothesis using a cross-fostering experiment where sibships were split and transferred in different nests of unrelated parents. The vocal begging performance of individual nestlings was measured under controlled laboratory conditions. The similarity in vocal begging intensity of

siblings growing in different nests was used as an estimate for its heritability. We tested parental response to begging calls using begging-playback experiments. The broad-sense heritability of vocal begging intensity, and the covariation between the biological parent's responsiveness and the offspring's begging behaviour were estimated. Information about heritable variances and covariances in parent-offspring communication may be necessary to understand its evolutionary potential.

### **KOLNAAR Rogier**

Institut de Biologie végétale; Université de Fribourg; rue Albert Gockel 3; CH-1700 Fribourg; Switzerland

#### Effect of *Puccinia lagenophorae* on competition between *Senecio vulgaris* and *Capsella bursa-pastoris*

The annual plants *Senecio vulgaris* L. and *Capsella bursa-pastoris* (L.) Medic. belong to similar communities occupying ruderal habitats. The host-specific rust fungus *Puccinia lagenophorae* Cooke infects *S. vulgaris* and infection alters the outcome of competition between *S. vulgaris* and *C. bursa-pastoris*. Depending on time of infection, competition is more or less affected. Epidemics of *P. lagenophorae* develop and may infect *S. vulgaris* plants within a population at various times. Can the development of *P. lagenophorae* epidemics be predicted, and thus, the effect of *P. lagenophorae* on plant competition at the population level? In the study presented the effect of temperature on epidemiological parameters of *S. vulgaris* on *P. lagenophorae* was determined. Plants were grown at different temperatures in two experiments. Incidence, latent period and severity were assessed. In one of the experiments, infectious period and spore production were assessed. Velocity of epidemic spread was estimated for plants grown at 10, 16 and 22°C. A temperature effect on latent period was detected in both experiments, whereas a temperature effect on incidence and severity was detected in only one experiment. Latent period increased by decreasing temperature. Spore production curves were fitted using the gamma function. A temperature effect was detected on infectious period and spore production. Data obtained in the study presented were used to estimate velocity of epidemic spread. A temperature effect on velocity was detected. Velocity of epidemic spread was highest on plants grown at 22°C and lowest on plants grown at 10°C.

### **KUENZLER Reto & BAKKER Theo C.M.**

Abt. Verhaltensoekologie; Zoologisches Institut; University of Bern; Wohlenstrasse 50a; CH-3032 Hinterkappelen; Switzerland

#### A study of multiple female preferences in sticklebacks using computer animations

The study of multiple mate preferences is handicapped by the impossibility of experimentally manipulating particular traits let alone combinations of traits. Previously used methods such as direct or indirect tests with live animals and video playback techniques can often not get round confounding variables and suffer from non-standardised variance within and between replicates. Choice tests using reality-based computer animations offer a solution because they feature fully controllable virtual animals in a defined surrounding. A 3D-model of a male stickleback was built based on the dimensions and proportions of an average male and its courtship movements were animated. Females were allowed to choose between two virtual males which only differed in the desired ornament(s) and that were presented simultaneously on a high-quality computer display. The female's attention towards animated males correlated positively with their attention towards a real courting male. First results of preference tests will be presented.

### **KUSKE Stefan**

Federal Research Station for Agroecology and Agriculture; CH-8046 Zürich; Switzerland

Does the mass release of the exotic egg parasitoid *Trichogramma brassicae* pose a risk to populations of endemic natural enemies ?

*Lydella thompsoni* Hert. (Diptera, Tachinidae) is a native larval parasitoid of the European Corn Borer and shows parasitism rates up to 50% in Ticino. The first generation of the tachinid develops on hosts in pristine habitats, such as *Archanara* spp. (Lepidoptera, Noctuidae), while the European Corn Borer is the main host for the subsequent generations. Maize seed producers carry out mass releases of the exotic egg parasitoid *Trichogramma brassicae* Bedz. (Hymenoptera, Chalcidoidea) to control the European Corn Borer, which is the key pest of maize in Ticino. These releases coincide with the oviposition period of known spring hosts of *L. thompsoni*. Preliminary studies have shown that a high percentage of *T. brassicae* can disperse from maize fields into pristine habitats in the surroundings where they search and might parasitize alternative hosts, such as *Archanara* spp. The present study investigates the importance of the exotic egg parasitoid *T. brassicae* in displacement processes of the endemic competitor *L. thompsoni*.

#### LAWTON John H.

NERC Centre for Population Biology; Imperial College; Silwood Park; Ascot, Berks SL5 7PY; United Kingdom

#### Biodiversity and ecosystem function

Field and laboratory experiments with model plant communities show clear evidence of a reduction in ecosystem processes (for instance productivity and nutrient cycling) with declining plant species richness within any one site. Comparisons made across different sites, however, yield more complex relationships, so that mixing within- and between-site effects is confusing. A robust body of emerging theory underpins and explains these empirical results. This talk will start by reviewing the theory, before briefly summarising the empirical data. I will then go on to present preliminary results from the European-wide BIODEPTH experiment to illustrate the key points. BIODEPTH has simulated the loss of plant species from model, grass/herb communities using identical experimental protocols at eight sites across Europe. The implications of these data and theory for conservation, in the face of the rapid loss of species from many surviving natural and semi-natural habitats, and for more intensely managed ecosystems and landscapes will be discussed. The remaining scientific challenges are: (i) To understand better the mechanism(s) underpinning ecosystem responses to loss of biodiversity. (ii) To distinguish between the role of biodiversity in maintaining ecosystem processes under constant, or benign environmental conditions, and under extreme environmental perturbations. The "insurance hypothesis" predicts that many apparently "redundant species" are essential for maintaining ecosystems under extreme events. (iii) To start to consider the role of animal and microbial diversity in ecosystem processes.

#### LUGON-MOULIN Nicolas, BRUNNER Harald, BALLOUX François, GOUDET Jérôme & HAUSSEER Jacques

Institut d'Ecologie; Laboratoire de Zoologie et Ecologie Animale; Bâtiment de Biologie; Université de Lausanne; CH-1015 Lausanne-Dorigny; Switzerland

Do riverine barriers, history or introgression shape the genetic structuring of a common shrew (*Sorex araneus*) population ?

The common shrew (*Sorex araneus*) is subdivided into numerous chromosome races. The Valais and Cordon chromosome races meet and hybridize at a mountain river in Les Houches (French Alps). A significant genetic structuring was recently reported among populations found on the Valais side of this hybrid zone. In this paper, a phylogenetic analysis and partial Mantel tests are used to investigate the patterns and causes of this structuring. A total of 185 shrews

were trapped at 12 localities. All individuals were typed for nine microsatellite loci. Although various mountain rivers are found in the study area, riverine barriers are not found to have a significant influence on gene flow. Partial Mantel tests show that our result is due to the influence of the hybrid zone with the Cordon race. The geographic patterns of this structuring are discussed in the context of the contact zone, which appears to extend up to a group of two rivers. The glacier they originate from is known to have cut the Arve valley as recently as 1818. The recent history of this glacier, its moraine and possibly rivers, may therefore be linked to the history of this hybrid zone.

### MACDONALD David

Zoology Department; South Parks Road; Oxford; Oxon OX1 3PS; United Kingdom

#### Alien invaders

Introduced alien species are a major factor in conservation. In particular, the American mink has been widely introduced around the world. This has revealed not only major problems for conservation, but also theoretically interesting insights in ecological theory. In Britain, for example, the American mink is largely responsible for a radical decline in the population of water voles. In Eastern Europe the American mink is responsible for the collapse in populations of European mink. These results, and their wider relevance, will be discussed.

### MATTHIES Diethart<sup>1</sup>, BRÄUER Ingo<sup>2</sup>, MAIBOM Wiebke<sup>2</sup> & TSCHARNTKE Teja<sup>2</sup>

<sup>1</sup> Institut für Umweltwissenschaften; Universität Zürich; Winterthurerstrasse 190; CH-8057 Zürich; Switzerland

<sup>2</sup> Fachgebiet Agrarökologie; Universität Göttingen; Waldweg 26; D-37073 Göttingen; Germany

#### Population size and risk of extinction in rare plants

In the mid 1980s the distribution and size of populations of endangered plant species in Lower Saxony (N-Germany) were recorded by the conservation authorities. We used these data as the basis for a study of the effects of population size on the probability of survival of local populations in eight rare plant species (*Gentianella germanica*, *G. ciliata*, *Lepidium campestre*, *Melampyrum arvense*, *M. nemorosum*, *Rhinanthus minor*, *R. serotinus* and *Thlaspi perfoliatum*). In 1996 we visited 359 known sites of these plants and recorded whether they still had extant populations. The risk of extinction of local populations was very high. Of the studied populations 28% had become extinct in the 10 years since the last census. Logistic regressions revealed significant negative relationships between population size and risk of extinction in seven of the eight studied species. The form of the relationship and the population size required for 90% probability of survival over 10 years varied strongly among species, suggesting that minimum population sizes required for persistence will vary among plant species.

### MICKASCH Tatjana M.

Zoological Museum of the University of Zurich; Winterthurerstrasse 190; CH-8057 Zürich; Switzerland

Is there a relationship between expanding *Orconectes mosus* and decreasing *Austropotamobius pallipes* populations in Switzerland ?

The white-clawed crayfish (*Austropotamobius pallipes*) is considered an endangered species in Switzerland. It is native to the waterbodies of the canton of Berne, Waadt and Wallis, where the American species *Orconectes limosus* occurs too. The first recording of *O. limosus* was 1979 in Lake Biel. Eversince, it expanded its range continuously, and early in 1998 it was found in the river Aare 90 km downstream of Lake Biel. Because of its resistance to crayfish plague (*Aphanomyces astaci*) it is a potential threat to the white-clawed crayfish. The aim of this

poster is to assess the actual and potential threat of *A. pallipes* by *O. limosus*. In summer and fall of 1997, 63 streams were checked and *O. limosus* was found in 17 out of 43 streams draining either into Lake Biel or the river Aare, but not in the remaining streams. *A. pallipes* was found only in 5 out of 20 streams where the species had been recorded since 1990 by local authorities. *O. limosus* was restricted to the immediate surroundings of the rivermouths. The probability of his occurrence was the higher, the wider the stream was and the denser it was in the river or the lake. There is no obvious connection between the decline of native white-clawed crayfish populations and the expansion range of *O. limosus*. Alternative explanations of the decline of the native species are either chemically or organically polluted water entering the streams more or less continuously, or short intervals of high phosphate and nitrate concentrations after heavy rainfall.

### MIKOS Z. Maja & WARD Paul I.

Zoologisches Museum der Universität Zürich; Winterthurerstrasse 190; CH-8057 Zürich, Switzerland

### Cryptic female choice of male genotype in the yellow dung fly (*Scathophaga stercoraria*)

Sperm competition in the yellow dung fly, (*Scathophaga stercoraria*), has been examined in great detail. Strong male-biased size dimorphism allows male behavioural control over copulation and fertilisation. Recent investigations point to internal cryptic control over fertilisation by the female. Females were mated to two males, with either a few hours or just over a day between the matings. All flies came from two different lines (Pgm-2, Pgm-3) selected for different alleles of the Pgm locus. I tested for effects of the male's genotype on copulation duration, latency and fertilisation success. The proportion of offspring fathered by the second male (P2) was scored using the Pgm marker. Results indicate that both the male's genotype and his genetic similarity to the female's genotype affected paternity. Paternity of males from Pgm-2 line was overall higher but females at the same time preferred males of a genotype different from her own. Males homozygous for allele 2 (Pgm-2) copulated longer and their latency to copulation was shorter. The experiment showed that female *S. stercoraria* uses cryptic choice to control paternity to overcome her lack of behavioural control.

### MORETTI Marco<sup>1</sup>, HÖRDEGEN Philipp<sup>2</sup>, CONEDERA Marco<sup>1</sup>, DUELLI Peter<sup>2</sup> & EDWARDS Peter J.<sup>3</sup>

<sup>1</sup> Swiss Federal Institute for Forest, Snow and Landscape Research: Station South of the Alps; CH-6504 Bellinzona; Switzerland

<sup>2</sup> Swiss Federal Institute for Forest, Snow and Landscape Research; CH-8903 Birmensdorf/ZH; Switzerland

<sup>3</sup> Geobotanical Institute: Swiss Federal Institute of Technology; Zürichbergstrasse 38; CH-8044 Zürich; Switzerland

### Response of invertebrates to wildfires. First results about spiders (Araneae) and ground beetles (Carabidae) in deciduous forests on the south part of the Alps (Ticino, Switzerland)

Current knowledge on the consequences of wildfire for faunistic biodiversity is fragmentary, particularly in deciduous forests south of the Alps, which is the region of Switzerland most affected by this phenomenon. After the second year of a doctoral thesis about "The influence of sporadic and regular fires on invertebrate biodiversity" planned for three years, we present some preliminary results. The aim of the project is to explore the effect of single and regular fires on the invertebrate fauna. The investigation is taking place in a hilly region in the chestnut belt (*Castanea sativa* forest). The study area is a south facing slope. We have sampled several invertebrate groups in 23 test areas: 7 areas affected by a single fire, 10 areas with repeated



fires and 6 control areas of intact forest. The soil fauna have been assessed using several standardised sampling methods: pitfall traps for epigeic arthropods, litter-soil samples and soil eclectors for soil dwelling groups, and yellow window traps for flying insects. Sampling period between January and October 1997. The first results show that among spiders and carabid beetles species react differently to fire. Some species of spider are already present a few days after the fire; however, other species seem to avoid burned areas. The highest number of species of spiders was recorded in 2 years old burned areas. The number of species of carabid beetles appears to be higher in forest areas which have burned frequently. Some first hypotheses based on these preliminary results are presented.

### MÜLLER Jürg P.

Bündner Natur-Museum; Masanerstrasse 31; CH-7000 Chur; Switzerland

The reintroduction of the Bearded Vulture, *Gypaetus barbatus*, in the Alps – an example for the practical project realisation

Due to a large-scale reintroduction project the first Bearded Vulture, *Gypaetus barbatus*, released into the wild are breeding again in the Alps, 100 years after their extinction. The project, which has been successful up to now, has the following milestones: the development of a breeding program, the choice of a suitable means of release, the choice of four release sites in the Alps as well as the establishment of a monitoring program.

Of great importance was the setting up of the breeding network and the decision not to take any animals from the endangered populations. Therefore, only a breeding program with about 50 birds, already in captivity and belonging to the Eurasian sub-species *Gypaetus barbatus barbatus* could be considered. Breeding stations were established in Vienna, Haute-Savoie and Goldau. For the breeding program additional pairs are kept in different zoos.

Today the breeding program functions very well. About 150 birds were brought up in captivity. 50% were set free, 50% were taken into the breeding stock.

A further decisive step was the choice of the method for release. Using the so-called "Hacking method", the birds are brought at an age of about 100 days without parents into an artificial nesting site. At that time, they are not able to fly, but start flying usually 20 days later. During this period the birds get a strong connection to the release site: a behaviour also called philopatry.

The choice of 4 release sites, distributed at regular intervals across the Alps, has a strong bearing on the release method. It is expected that the birds, because of their philopatric behaviour will, in the majority of cases, stay in the range of their release area and preferably hatch there. In this way, nuclei of populations are created from which a whole population can build up in the Alps.

The next step was to draw up a monitoring project: Monitoring is understood as the comparison of the target situation, i.e. a self-sustaining population in the Alps, with the present situation at a certain point in time. As long as these situations differ from each other, the project should be continued. In detail, monitoring also serves to discover wrong developments and therefore wrong decisions. So the monitoring program encompasses a whole range of scientific projects.

At the present time following scientific programs are being carried out in the Swiss project:

The spread of the birds over the Alps and their survival is monitored with the help of amateur field observers such as ornithologists and game guards, reporting their sightings to the project data bank.

The development of the young at the release sites and the formation of pairs is followed up by zoologists, charged by the reintroduction project.

The fact of small populations both in the breeding network and in the wild, require a genetic management plan. The basic study is carried out by Barbara Gautschi from Zurich University.

I would be wrong to believe that the monitoring program allows us a very precise regulation of the project. If the breeding methods were unsuitable and the birds would not hatch in the wild then one would have to rethink the whole project entirely. Monitoring also has an important

documentary and scientific value. In this way one can follow the establishment of a population in a previously uninhabited area.

Up to now 80 birds have been released, of which about 50 survived. Breeding of released birds took place in Haute-Savoie (1997 and 1998) and in the Stelvio National Park (1998). There, the birds obviously have started breeding again: so that there is much hope they will reproduce also this year.

In a reintroduction project spanning the whole region of the Alps and crossing country borders, great observance had to be given to the internal flow of information. An own bulletin, annual meetings and workshops serve to train the people involved. The public relation work proves an extremely important feature. It is prerequisite for the acceptance of the project by the population and the authorities (permission) and for successful funding. Contributions to television, radio and printed media are decisive to the project becoming well known. Books, brochures and exhibitions have a long term educational effect while lectures are suited to winning over local interest groups (local population, hunters, authorities, ornithologists) and to discussing criticism of the project.

A difficult exercise in managing the project besides the specific expertise problems is the leadership of the many different persons involved. Many take part for very different reasons and therefore have very different expectations of the project.

In order to carry out this sort of project and to make the necessary decisions, information of various types are needed: practical knowledge about keeping animals, results of specially initiated basic research, studies with the characteristics of environmental impact assessments, extensive and intensive monitoring, project management and public relations.

Zoologists who want to take part in such projects need more and better-organised opportunities for practical training and for further education in addition to their purely scientific field.

**OERTLI Beat, AUDERSET-JOYE Dominique, JUGE Raphaëlle, CASTELLA Emmanuel, MÜLLER Jessica, ANTOINE Céline, SAAM Mirko, CAMBIN Diana & LACHAVANNE Jean-Bernard**

Laboratoire d'Ecologie et de Biologie aquatique; University of Geneva; chemin des Clochettes 18; CH-1206 Genève; Switzerland

**Biodiversity in Swiss ponds: how biotic communities respond to altitude**

This large-scale project supported by the Swiss Federal Office for Environment, Forest and Landscape is an investigation of environmental conditions and biodiversity over a wide range of small waterbodies. It aims at: (1) categorising waterbodies and their associated plant and invertebrate diversity, (2) deriving predictive relationships between a set of environmental characteristics of the ponds (structure of the environment, water quality ...) and their biotic richness and composition, (3) setting up a standardised method for the assessment of the conservation value of ponds. The first results demonstrate the preponderance of altitude in governing diversity of Swiss ponds and a quantification of this tendency is proposed. Altitude also plays a key rule in the typology of the ponds.

**OLIVIERI Isabelle**

Institut des Sciences de l'Evolution; Université Montpellier 2; place Eugène Bataillon; F-34095 Montpellier cedex 05; France

**Contribution of metapopulation-level studies to the understanding of extinction, adaptation, and speciation**

The evolutionary potential of a species is of primary concern in conservation biology. Such evolutionary potential may be described by the genetic and phenotypic diversity of a species, its colonising ability, as well as by its propensity to locally adapt and eventually speciate. Clearly, studies above the population-level are a necessary step towards an understanding of what

determines a species niche breadth. In this talk, I will describe how the evolution of dispersal might affect the evolutionary potential of a species, by taking examples from widespread and endemic plant species. I will then describe how the evolution of dispersal and habitat selection through host choice can lead to local adaptation and eventually speciation in herbivorous insects. Methods used range from mathematical models to demographic surveys of natural populations, through population and quantitative genetics studies.

### **PASCHKE Melanie**

Institut für Umweltwissenschaften; Universität Zürich; Winterthurerstrasse 190; CH-8057 Zürich; Switzerland

Does genetic variation matter ?

The theoretical background of loss of genetic variation in small populations of plant species is well discussed. Reduced genetic variation is thought to decrease the future capability of a population to adapt to environmental changes. However, theoretical predictions so far have not been critically evaluated in the field. It is still unclear if under stressful environmental conditions genetic variation in itself is more important for the survival of a population than the phenotypic plasticity of the individuals. The hexaploid *Cochlearia bavarica* (Brassicaceae, Vogt 1985) is endemic to Bavaria and highly endangered. It is a perennial, self-incompatible plant. In a previous study a reduced genetic variation and reproduction was observed in small populations of the species. In the present study I now ask the following questions: 1) Is high genetic variation within populations important for plant performance in the field and is this relationship independent of population size ? 2) Is high genetic variation within populations important for the coping with environmental stress ? I carried out two experiments to address these questions: transplantation experiment: performance of plants in own/foreign environments.

### **PASINELLI Gilberto**

Zoological Museum and Institute; University of Zurich; Winterthurerstrasse 190; CH-8057 Zürich; Switzerland

Effects of habitat structure on home range size and breeding success of the middle spotted woodpecker *Dendrocopos medius*

The endangered middle spotted woodpecker is restricted to old oak forests, which are rapidly disappearing due to inappropriate forest management. The relationships between habitat factors, home range size and breeding success of this species was investigated during a five year study based on 33 radio-tracked birds. Multivariate analyses revealed that home range size was inversely related to a) the density of potential cavity trees and b) three variables potentially linked to food supply, namely the densities of large oaks ( $\geq 36$  cm dbh) and rough-barked trees as well as the amount of dead limbs in crowns. None of these four variables was related to breeding success, suggesting that the middle spotted woodpecker adjusts home range size to habitat quality. Management decisions in favour of this woodpecker should not only focus on the conservation and promotion of large oaks, but also on the supply of trees suited for cavity excavation.

### **PASTORINI Jennifer<sup>1</sup>, FORSTNER Michael R. J.<sup>2</sup> & MARTIN Robert D.<sup>1</sup>**

<sup>1</sup> Anthropologisches Institut; Universität Zürich; Winterthurerstrasse 190; CH-8057 Zürich; Switzerland

<sup>2</sup> Florida Atlantic University; Division of Science; Dept. of Biology; 2912 College Avenue; Davie FL 33314; USA

Phylogenetic relationships among Lemuridae (Primates) inferred from DNA sequences

The family Lemuridae includes 4 genera: *Eulemur*, *Hapalemur*, *Lemur*, *Varecia*. Phylogenetic trees based on morphology generally place *Hapalemur* as the most basal offshoot. By contrast, genetic and behavioural studies have consistently placed *Hapalemur* as the sister-group to *Lemur*, with *Varecia* as a basal offshoot. Nodal relationships among *Eulemur* species also remain contentious. A mitochondrial DNA sequence data set from the ND3, ND4L, ND4 genes and 5tRNAs (Gly, Arg, His, Ser, Leu) was generated to try to clarify phylogenetic relationships within the Lemuridae. We extracted DNA from hair, blood or tissue samples from all species of all four lemurid genera and various outgroup taxa were also included. The ~2400 bp sequences were analysed using maximum parsimony, neighbour-joining and maximum likelihood. The results support a basal position for *Varecia*, a sister-group relationship for *Lemur/Hapalemur* and monophyly of *Eulemur*, but relationships among *Eulemur* species were not clearly resolved. One clade contains *mongoz*, *rubriventer*, and *fulvus*; *macaco* and *coronatus* form the second clade. *H. griseus* and *H. aureus* form a clade with strong support, but the sequence data do not yield resolution of the trichotomy involving *H. simus*, *H. aureus/H. griseus* and *L. catta*. Pairwise distances among all 4 taxa are approximately equal; there is no increase in genetic distance between *Lemur* and *Hapalemur*. Although our preliminary results do not definitively show whether *Hapalemur* is paraphyletic, they do at least strongly support a sister-group relationship for *Lemur* and *Hapalemur*.

**PERRET Mathieu, SAVOLAINEN Vincent, CHAUTEMS Alain & SPICHTER Rodolphe**

Conservatoire et Jardin botaniques de la Ville de Genève; chemin de l'Impératrice 1; CH-1292 Chambésy; Switzerland

Pollination systems and speciation in Sinningieae (Gesneriaceae, Angiosperm)

In angiosperms, plant-pollinator interactions have been suggested to play a major role in speciation, but few studies have addressed how such ecological relationships originate and evolve. In the present study, we have chosen a phyletic approach in the plant tribe Sinningieae. These herbaceous/shrubby plants from the Neotropics are pollinated by bees, butterflies, moths, hummingbirds or bats. The major question that we address is how speciation occurs at the plant-animal interface, viz. how pollination systems versus allo/sympatry took part in the biodiversification process of these gesneriads. For this purpose, we inferred the phylogeny of all plant species (75 sp.) using DNA data from three noncoding regions of the plastid genome (trnL-trnF, rbcL-atpB and rpl16). In addition, since sugar ratios have been correlated with pollinator identity, nectar has been collected and analysed. These rewards, together with the morphological syndromes, have been mapped onto the phylogeny to trace the evolutionary events that should have given rise to the modern distribution of ecological features. In the case of species with a wide geographical distribution, we show how sympatric speciation could have occurred with pollinator switches. By contrast, in the case of clades containing species with the same pollinator, we show that speciation has relied on geographical isolation or minute morphological specializations to specific pollinators. Finally we discuss complementary approaches (population/field experiments, developmental genetics) that will be developed in the near future.

**PERRIN Nicolas, BALLOUX François & GOUDET Jérôme**

Institute of Ecology; Biology Building; University of Lausanne; CH-1015 Lausanne; Switzerland

Breeding systems inferred from genetic structures

We investigate the possibility to infer the parameter values of breeding systems (number and size of breeding groups within subpopulations, sex-specific dispersal, polygyny level) from field estimates of the amount and apportionment of genetic variance (hierarchical Fst). The approach is illustrated for the case of *Crocodyrus russula*, a monogamous shrew with female-biased dispersal.

**PFLUGSHAUPT Kaspar & KOLLMAN Johannes**

Geobotanisches Institut ETH; Zürichbergstrasse 38; CH-8044 Zürich; Switzerland

**Reproductive traits in small and isolated populations of *Prunus mahaleb***

At the margin of its distribution in central Europe *Prunus mahaleb* is confined to steep, south-facing cliffs and scree slopes which have a particular sunny and warm microclimate. The fleshy-fruited shrub is widespread in the Mediterranean basin and extended its area of distribution towards central Europe during a warmer period after the last glaciation. Thus, the relictic populations in central Europe have been isolated for about 5,000-6,000 years. To investigate the effects of isolation and population size on reproduction of *P. mahaleb* several flower and fruit traits were sampled in eleven small and isolated populations in Switzerland. Mean fruit pulp mass and seed mass were tightly correlated across all populations, and positively correlated with flower size. Flower size, pulp and seed mass correlated neither with population size nor with the degree of isolation. However, the three variables showed a significant negative correlation with the altitude of the study sites. In a Principle Component Analysis (PCA) seven of the populations were clearly differentiated by their reproductive traits. The first axis of the PCA was mainly determined by flower size, pulp and seed mass; this axis ran parallel to a gradient in precipitation. The second and third axes correlated with the number of flowers and fruits per raceme, and percentage abortion of immature fruits within the racemes. These results suggest that climatic factors are more important to explain the observed variation in flower and fruit traits than population size or the degree of isolation.

**PULFER Corinne, OERTLI Beat, CASTELLA Emmanuel & CAMBIN Diana**

Laboratoire d'Ecologie et de Biologie Aquatique; University of Geneva; chemin des Clochettes 18; CH-1206 Genève; Switzerland

**Biodiversity of Trichoptera in Swiss ponds**

Within the framework of a larger project aiming at the classification of ponds in Switzerland and the set up of an assessment method for the conservation value of these ecosystems, larval Trichoptera assemblages were surveyed in 56 ponds varying in altitudinal range, morphometry and nutrient status. Sampling was carried out on a habitat basis, accounting for all the major habitat types occurring in the ponds. Relationships between the occurrence of the 35 taxa found and a set of environmental variables (structure of the pond surrounding, water quality) are presented. They stress altitude as a prominent constraint for the prediction of trichopteran diversity.

**REUTER Max & KELLER Laurent**

Institute of Zoology and Animal Ecology; University of Lausanne; Bâtiment de Biologie; CH-1015 Lausanne; Switzerland

**Conflict over caste determination in eusocial hymenoptera**

Haplodiploidy makes that in the eusocial hymenoptera workers favour a female-biased sex ratio whereas the queen prefers an equal investment in male and female sexuals. Although both workers and gynes develop from female eggs (caste determination occurring during the larval stage), we show in a simple model, that the evolutionary stable (ES) investment in workers for the queen and the workers do not differ, if the number of female eggs available is not limited. In this case, workers are not produced at the expense of gynes. Introducing a constraint on the adult sex ratio (gynes and workers to males) in our model, we find that the workers' ES investment in worker production is lower than that of the queen. At the workers optimum, overall sexual production (a function of investment in workers) is smaller than at the queen's ES strategy (ESS), but the sex ratio is more female biased. If worker-gyne determination is under control of the developing larvae themselves, the ES investment in workers is slightly

lower than at the workers' ESS. Our results indicate that considerable conflict over caste determination arises between the queen on one hand and the workers and female larvae on the other. Worker-larvae conflict, in contrast, is almost insignificant.

### **RIBI Georg**

Zoologisches Museum der Universität Zürich; Winterthurerstrasse 190; CH-8057 Zürich; Switzerland

Habitat alterations facilitate genetic introgression between European *Viviparus* species (Mollusca, Prosobranchia)

*Viviparus ater* lives in lakes and rivers, whereas *V. contectus* originally lived in semi-permanent swamps, ponds and small streams. However, swamps have been drained throughout Europe and *V. contectus* has lost most of its preferred habitats. On the other hand, new habitats such as canals and harbours have been created which are suitable to both species, and where they now live sympatrically. Since *V. ater* and *V. contectus* have been found to coexist only in disturbed or man-made habitats, it can be assumed that the two species occupied different habitats during most of their evolutionary history, and that it is only now that coexistence between them is widespread. This may also be an explanation for the fact that the two species, despite pronounced differences in many characters, can still hybridise. Hybrids are fertile in backcrosses with both parental species. Natural hybrids and backcrosses were found in Lake Garda, Italy, and electrophoretic data suggest that genetic introgression may occur between *V. ater* and *V. contectus*. Although introgression may have only just started, the high frequency of interspecific copulations in nature, the high survival rate and the high fecundity of hybrids and backcrosses suggests that there is a high potential for introgression. This is an example of genetic changes of natural populations probably brought about by man made habitat alterations.

### **RIGBY Mark C. & JOKELA Jukka**

ETH Zürich; Experimental Ecology; ETH Zentrum NW; CH-8092 Zürich; Switzerland

High costs of predator avoidance compromise immune defences in snails (*Lymnaea stagnalis*)

Organisms are often attacked simultaneously by several kinds of enemies, requiring different defences. The optimal level of defence is a balance between the costs and benefits of defence. However, with multiple enemies, the allocation to one defence may constrain the necessary allocation to another defence. Here, we show that two different defence strategies have substantial interacting fitness costs. We manipulated the allocation to predator avoidance and immune defence in the freshwater pond snail *Lymnaea stagnalis*. Increasing predator avoidance correspondingly reduced energetic reserves, the proportion of snails reproducing, and reproductive output. Immune challenge imposed high costs when predator avoidance was infrequent, but lower costs when predator avoidance was frequent. This suggests that snails trade immune defences for predator avoidance, weakening their ability to defend against parasites when predators are abundant.

### **ROMER Jann**

Zoologisches Museum der Universität Zürich; Winterthurerstrasse 190; CH-8057 Zürich; Switzerland

*Astacus leptodactylus* - a threat to native species in Lake Aegeri, Switzerland ?

Lake Ägeri hosts three crayfish species: *Austropotamobius torrentium*, *Astacus astacus* and *Astacus leptodactylus*. The last species, originally from Eastern and South-eastern Europe, was caught for the first time in Switzerland in 1979. It has a higher reproductive rate and grows

faster than the two indigenous species (*Au. torrentium* & *As. astacus*). To estimate the potential of *As. leptodactylus* to affect indigenous species in Lake Ägeri, I examined the distribution and relative densities of the three species and their association with different substrate types, collecting plot samples by SCUBA-diving. I found crayfish at 29 of 33 sites between April and September 1997. I found only one species at 8 sites, two species at 15 sites and all three species at 6 sites. Species composition differed significantly between sites according to substrate composition. *Au. torrentium* prefers stony substrate, while the two *Astacus* species were more frequent at sites with muddy substrate and reed vegetation. In all three species, I found gravid females and recently hatched juveniles and all size classes were present. Animals missing appendages were more often *As. astacus* than either of the two other species. Limb loss was significantly more frequent in *As. astacus* at sites where the introduced species (*As. leptodactylus*) was present at high densities. This suggests that *As. leptodactylus* is dominant in competitive interactions with *As. astacus* and the potential for competitive exclusion exists.

### **ROULIN Alexandre, KÖLLIKER Mathias & RICHNER Heinz**

Department of Zoology; University of Bern; CH-3032 Hinterkappelen; Switzerland

#### Hawk-dove games among offspring of *Tyto alba*

Conflicting parent-offspring interactions are among the most common behaviours in both humans and animals. Models of offspring begging propose two possible outcomes of the conflict where either scramble competition among siblings leads to escalated begging level to attract the parents' attention, or where begging is a honest indicator of food need directed at the parents. However, nestlings may also use each other's vocalisation behaviour to decide whether to escalate or retreat in a contest over food, as in a game theoretical model with conditional Hawk-Dove strategies. Following game theory, a nestling should play Dove when a nestmate vocalises more intensely and may therefore be willing to escalate in the contest over the next food item delivered, and he should then increase vocalisation once this nestmate has consumed the prey. Such a change in vocalisation is not predicted by both scramble competition and honest signalling models. All three experiments in wild barn owls *Tyto alba* suggest that nestlings are sensitive to each others vocalisation level in a manner consistent with the conditional Hawk-Dove strategies. The findings suggest that the understanding of parent-offspring conflict may require the incorporation of a game theoretical approach of asymmetric contest into current begging models.

### **ROY Bitty, LANDOLT Martin, GAECHTER Fani & SCHMID Bernhard**

Geobotanisches Inst. ETH; Zürich; und Institut für Umweltwissenschaften; UNI Zürich; Switzerland

#### Relationships between biodiversity and enemy attack rates

Theory suggests that disease and herbivory should be more prevalent where plant biodiversity is low, because effective host density is correspondingly high, and high host density should facilitate transmission. To assess this idea experimentally, we quantified disease levels and herbivore attack in a the BIODDEPTH experimental plots in Switzerland. Plant diversities per plot were 1, 4, 8, or 32 plant species per plot. Our 1998 data show that of the nine natural enemies studied on three different hosts, 5 were more prevalent in the lowest-diversity plots (in agreement with theory), but 9 were more prevalent in higher-diversity plots (violating the predictions of theory). These results suggest that the individual ecology of each disease or insect must be considered before host diversity levels can be used to predict attack rates.

### **RUSTERHOLZ Hans-Peter & ERHARDT Andreas**

Department of Integrative Biology; Section of Conservation Biology (NLU); St. Johannis-Vorstadt 10; University of Basel; CH-4056 Basel; Switzerland

### Influence of human land-use change on the genetic population structure of the Adonis Blue butterfly (*Lysandra bellargus* Rott)

Today, habitat fragmentation is one of the most important processes causing losses of biodiversity and increasing species extinction rates. Consequently, assessment of population genetic structure and diversity is increasingly relevant for the management for threatened species. In this study, RAPD-PCR analyses are used to investigate the effects of habitat fragmentation on the genetic structure of Adonis Blue butterfly populations in the northwestern Jura mountains. Twelve populations ranging from small (estimated population size: 10-30 individuals) to medium (35-70 individuals) to large (200-500 individuals) were investigated. Our study shows that: (1) genetic diversity and hence molecular variance are reduced in the small populations, and (2) these two measurements do not differ between medium and large populations, (3) molecular variance between populations are high (35%), (4) there was neither a correlation between genetic distances and geographical distances, nor did clustering of the genetic phenotypes correspond to the geographic locations of the study sites, and (5) all investigated populations are highly isolated (range of calculated gene flow between populations:  $1 \times 10^{-4}$  to  $8 \times 10^{-5}$ ). This example shows that man-made changes of landscape can reduce and fragment butterfly populations with the associated genetic consequences. These findings are of particular relevance for conservation, since they suggest that fragmentation of formerly large butterfly populations causes disruption of gene flow and genetic erosion in small relic butterfly populations.

### **RYSER Peter, ZOBEL Kristjan, EEK Liina, URBAS Pille & WAHL Stefan**

Geobotanisches Institut ETH Zürich; Gladbachstrasse 114; CH-8044 Zürich; Switzerland  
Department of Botany and Ecology; Tartu University; Lai 40; EE-2400 Tartu; Estonia

#### Plant characteristics which drive succession

Artificial grasslands were grown in pots for two years at two levels of irradiance and nutrients. Species mixtures consisted of three combinations of ten ecologically contrasting grass species each. Although the treatments provoked a clear response in growth and plant morphology, there were no differences in species composition of the swards after the first growing season. The proportion of a species in the sward after one growing season correlated negatively with its leaf tissue density and its root tissue density. A low tissue density is known to be associated with a high inherent relative growth rate of a species. Initially dominant species had shorter leaf life-spans and faster root turnover rates. In full daylight the average leaf life-span of the sward increased and the average root turnover rate decreased in the second year due to shifts in species composition. In shade, however, a strong increase of two species with high turnover rates, *Poa trivialis* and *Dactylis glomerata*, counteracted the general increase of species with low turnover rates. We conclude that the initial course of succession is largely independent of environmental conditions. Among the species present at a site, fast growing species with a low tissue density initially dominate the vegetation regardless of irradiance or nutrient supply. These species have shorter leaf life spans and faster root turnover rates, which indicate that their relative abundance would diminish in the course of a succession. However, this was only partly confirmed by the data of the second growing season.

### **SALAMIN Nicolas, RUEDI Manuel & SAVOLAINEN Vincent**

Institute of Ecology, University of Lausanne, CH-1015 Lausanne; Switzerland

#### Inferring complex phylogenies: which strategy to adopt ?

During the evolution of species, speciation and extinction events were far from uniform. In particular, many groups of organisms experienced rapid diversification known as adaptive radiation. These radiations occurred during short intervals of time, making phylogenetic reconstruction difficult. Moreover, these radiations may happen at different times within the same



organismal history, further complicating reconstruction. Among several possible strategies to overcome such complexities, it is often proposed to combine a rapidly evolving gene (i.e. expected to best resolve recent radiations) with data from a slowly evolving gene (i.e. expected to best resolve ancient radiations). We have investigated this hypothesis by a series of simulations. Sequences evolving at different rates were simulated along a model tree involving a recent and an ancient radiation. Performances of phylogenetic reconstruction were compared for rapidly and slowly evolving genes, analysed separately, or in combination. Even with extensive data sets, neither strategy was completely successful. We then argue for a more refined strategy and test these recommendations with real DNA data sets.

### **SCHIEGG Karin**

Chair of Nature and Landscape Protection; Swiss Federal Institute of Technology; c/o WSL; CH-8903 Birmensdorf; Switzerland

#### **Patch size and patch connectivity: habitat relationships of saproxylic Diptera and Coleoptera**

The intensive forest exploitation during the past centuries almost eradicated dead wood from Central European forests. Species confined to dead wood do not only suffer from habitat destruction but also from the effects of fragmentation. I studied the influence of volume and spatial arrangement of dead wood on saproxylic Diptera and Coleoptera at different scales. Dead wood connectivity was a better predictor of species richness and diversity than dead wood volume. The abundances of saproxylic Diptera and Coleoptera were influenced by the presence of dead wood within 150 m around the traps. Thus, a network of 'dead wood islands' each of about 7 ha in size would be optimal for the effective conservation of saproxylic insects in Central European forests.

### **SCHIEGG Karin**

Chair of Nature and Landscape Protection; Swiss Federal Institute of Technology; c/o WSL; CH-8903 Birmensdorf; Switzerland

#### **Small but beautiful: influence of dead wood dimensions on species richness and diversity of saproxylic insects**

Dead wood is a major component of forest ecosystems providing habitat for a variety of species. The intensive forestry during the past centuries nearly eradicated all dead wood, at least in Central European forests and, as a consequence, the saproxylic fauna depauperated. Efforts made to promote dead wood mostly focus on logs and snags as these are thought to be ecologically more important than branches or twigs. I studied species richness, diversity and species abundance distributions of saproxylic Diptera and Coleoptera reared from logs and branches of beech (*Fagus sylvatica*) using electors (emergence traps). In both insect groups, branches hosted more species, more rare and exclusive species and higher diversity than logs. Thus, activities for maintaining and enhancing forest biodiversity must also include the preservation of dead branches.

### **SCHÜRCH Stéphanie, PFUNDER Monika & ROY Barbara A.**

Geobotanisches Institut ETH; Zürichbergstrasse 38; CH-8044 Zürich; Switzerland

#### **Interactions between ants, *Euphorbia cyparissias*, and its pathogenic rust fungi**

Ants form a mutualism with *Euphorbia cyparissias* L. since they disperse its seeds which are specially provisioned with a food body (elaiosome). Ants also make up more than 35% of all visitors to the flowers of *E. cyparissias* and to its parasitic rust fungi (which require insects for reproduction). In this study, we asked whether the mutualism with ants also extends to

pollination of the flowers. In addition, we wondered whether ants fertilised its pathogens as well. A mating system experiment established that *E. cyparissias* can self, but it set more seeds when outcrossed. Insect exclusion experiments showed that ants do pollinate the flowers, but do not fertilise the fungi. Thus ants have positive interactions with the plants and no effect on its pathogens.

### **SOLIVA Marco & WIDMER Alex**

Geobotanisches Institut ETH; Zollikerstrasse 107; CH-8008 Zürich; Switzerland

#### Phylogenetic relationships within the orchid genus *Ophrys* based on multiple DNA sequences

The genus *Ophrys* shows a highly specialised pollination system. Flowers imitate female hymenopterans and provoke males to copulate with the flowers. If a male tries to copulate with flowers from different plants, pollination can occur. This type of pollinator exploitation is known as pollination by sexual deceit and is often highly specific. Due to this specificity, strong isolation among plant gene pools should be given. On the other hand, hybrids among species have been reported and morphological boundaries are often blurred. To assess phylogenetic relationships among *Ophrys* taxa, we have chosen DNA sequences from the nuclear and the chloroplast genome. The data set from the nuclear genome (ITS sequences) comprises 706 characters, 34 of which were parsimony-informative for the ingroup. Maximum parsimony (MP) analyses produced 6 shortest trees. The strict consensus tree contains 3 polytomies. The cpDNA data set comprises 978 characters of which 28 were parsimony-informative for the ingroup. Cladistic analyses produced 32.677 most-parsimonious trees. Two polytomies exist in the strict consensus tree. Strict consensus trees based on nuclear and chloroplast DNA sequence variation are largely congruent. One apparent difference between the two trees is the position of the *O. fuciflora* complex. According to the ITS sequences they form a separate lineage. In contrast, in the cpDNA tree the complexes *O. argolica*, *O. fuciflora* and *O. sphogodes* form a large polytomy. This difference may be due to different levels of variability of the two considered regions. Over all, the large polytomies suggest that most *Ophrys* species have diverged relatively recently.

### **STEPHAN André, MEYER Andrea & SCHMID Bernhard**

Institut für Umweltwissenschaft; Universität; Winterthurerstrasse 190; CH-8057 Zürich; Switzerland

#### Plant diversity positively affects soil microbial diversity

Soil microbial diversity is neither easily measurable nor precisely defined. Measurements of potential C-source utilisation by microbial communities can be done with BIOLOG plates. The resulting patterns of C-source utilisation represent an informative projection of the soil microbial community structure. We applied this technique (BIOLOG EcoPlates with 31 C-sources) to soil samples taken from an experiment designed to assess the effects of plant diversity on ecosystem functioning. In this experiment special emphasis was given to true replication of the plant diversity levels and to the influence of the functional groups grasses, herbs and legumes. We found that increasing plant species richness (log-scale) led to linear increases in (1) total soil bacterial activity ( $p < 0.01$ ) and (2) soil bacterial diversity measured by the C-source utilisation patterns (richness  $p < 0.05$ , Simpson-Index  $p < 0.01$ , Shannon-Wiener index  $p < 0.05$ ). More precisely, (3) the microbial activity increased with plant species richness on more than half of the 31 investigated C-sources ( $p < 0.001$  for 3,  $p < 0.01$  for 7,  $p < 0.05$  for 2,  $p < 0.1$  for 4 C-sources), whereas no decline in activity was found for any C-source. Furthermore, (4) soil microbial activity linearly increased with increasing number of plant functional groups ( $p < 0.01$ ). Finally, (5) the three plant functional groups differentially stimulated the soil microbial activity in the order legumes > herbs > grasses ( $p < 0.05$  for 3,  $p < 0.01$  for 2,  $p < 0.001$  for 1 of the 31 C-sources).

**STUDER Sibylle<sup>1</sup>, EDWARDS Peter J.<sup>2</sup> & MEISTER Erhard<sup>1</sup>**

<sup>1</sup> Swiss Federal Research Station for Agroecology and Agriculture; Reckenholzstrasse 191; CH-8046 Zürich; Switzerland

<sup>2</sup> Geobotanical Institute ETH Zurich; Zürichbergstrasse 38; CH-8044 Zürich; Switzerland

**Enhancing biodiversity in agricultural grasslands: plant community structure under different managements**

We are studying the effects of different management systems and of landscape structure on insect (true bugs) and plant diversity in grasslands. This poster focuses on plant community structure of differently managed grasslands. The study site is an area of some 3.5 km<sup>2</sup> in the Schaffhauser Randen in Northern Switzerland. The three administratively recognised management types are: extensive (no fertiliser, one cut), little intensive (little manure addition, two cuts) and medium intensive (moderate fertilisation (mineral or manure/slurry)). For each management type plant species composition has been assessed in twelve locations (replicates). As expected, species richness was highest in extensively used meadows (42 species per 6 m<sup>2</sup>) and lowest in the medium intensive type (30 species per 6 m<sup>2</sup>). The little intensive type was intermediate (35 sp. per 6 m<sup>2</sup>). However, in the ordination analysis (CA) the little intensive type clearly forms a separate group. The results concerning community structure (discussed below) also emphasise the special position of this grassland type. The dominance structure in the little intensive type differs considerably from the other two. In contrast to the extensive and the medium intensive types, the rank abundance distributions of the little intensive type show no clearly dominant species. Furthermore, rank consistency of the 10 most abundant species is lowest in the little intensive type. This means that a relatively large number of species can reach intermediate to high cover values and that a broad range of species can survive in these habitats. We conclude that the little intensive grassland type is of importance and that further work is required to assess its value for conservation of biodiversity in grasslands.

**SUTER Werner**

WSL; Birmensdorferstrasse 111; CH-8903 Birmensdorf; Switzerland

**A biodiversity strategy as a national nature conservation concept**

Nature conservation today is in transition from the period, when action meant mainly reaction, to a new era of planned conservation as an integral part of land-use activities. Since there is little difference between nature and biodiversity conservation, the mandate from the convention on biological diversity (Rio de Janeiro 1992) to prepare and implement national biodiversity strategies should be taken by the member countries as an opportunity to develop comprehensive plans for nature conservation. Using Switzerland as an example of the many countries which have not yet embarked on preparing such a strategy, it is argued that monitoring schemes, no matter how good they are, cannot substitute for genuine conservation strategies, but should be seen as instruments for measuring their success. Conservation biology should play a stronger role in the process leading towards a comprehensive national conservation plan. There will be a number of elements central to such a strategy: 1) To define the national role in conserving biodiversity. 2) To state the main goal of the strategy (e.g. conservation of net species numbers). 3) To define target entities of the strategy at different levels (genetic, species, and ecosystems) and the criteria for their measurement (e.g. size of minimum viable populations, minimum size and distribution patterns of biotopes, etc.). 4) To set priorities according to the country's responsibility for species and biotopes. 5) To quantify goals separately for each biogeographical region (habitats ?). 6) To develop ideas of how not only populations and biotopes, but also ecological processes can be conserved, and evaluate where alternative management options (managing the cultural landscape versus letting wilderness develop) are appropriate.

**THURNHEER SYLVIE<sup>1</sup> & ANHOLT BRADLEY R.<sup>2</sup>**

<sup>1</sup> Institute of Zoology; University of Zurich; Winterthurerstrasse 190; CH-8057 Zürich; Switzerland

<sup>2</sup> Department of Biology; University of Victoria; PO Box 3200; Victoria BC; V8W 3N5; Canada

Higher order interactions: The influence of predator-induced indirect effects on competitive ability in waterfrog larvae (*Rana esculenta* and *Rana lessonae*)

Predators do not only reduce prey density, but also induce behavioural responses in prey species. In waterfrogs, tadpoles of the hybrid *Rana esculenta* and the parental species *R. lessonae*, reduce their activity in the presence of predators. Since the amount of reduction differs between the genotypes, this non-lethal effect of predators can potentially change the competitive ability of their larvae. We investigated this possibility by measuring feeding rates and development for tadpoles of *R. lessonae* and 3 hemiclones of *R. esculenta* in the absence and presence of an odonate predator (*Aeshna cyanea*). At the beginning of the larval period (first month), *R. esculenta* fed and grew more in the presence than in the absence of *Aeshna*, contrary to our expectation. *R. lessonae* fed and grew equally in both treatments. Thereafter, *R. esculenta* reversed the pattern, feeding equally but growing less when *Aeshna* was present. For *R. lessonae* time to and size at metamorphosis did not differ between treatments. In contrast, *R. esculenta* hemiclone GUT3 metamorphosed earlier or hemiclone GUT2 slightly heavier when *Aeshna* was present. This surprising outcome may result from differential reduction of the swimming activity and, hence, energy expenditure of the genotypes. But whatever the mechanism, *Aeshna* predators seem to favour the competitive ability of *R. esculenta*.

**ULLRICH Karin S. & EDWARDS Peter J.**

Geobotanical Institute; ETHZ; Zürichbergstrasse 38; CH-8044 Zürich; Switzerland

Enhancing biodiversity in arable land: the role of management and landscape structure

The intensification of agriculture in Europe within the last decades has led to changes in landscape structure and considerable reduction of biological diversity in agricultural systems. There is now great interest in finding ways of managing such systems to preserve and enhance biological diversity, partly for conservation reasons and partly to achieve greater sustainability. To this purpose the Swiss policy strongly promotes the introduction of ecological compensation areas, such as wild flower strips, set-asides and hedges, in intensively-used arable land. The objective of this study is: 1. To compare the effectiveness of different management schemes in enhancing floristic and faunistic diversity within some of the ecological compensation areas, especially wild flower strips. 2. To examine how ecological compensation areas contribute to biological diversity at a landscape level. The abundance and diversity of plants and insects (Heteroptera) in wild flower strips is being compared and interpreted in terms of the management and the landscape structure. In particular interest focuses on the contribution of spontaneously appearing species. An experimental approach has been used to investigate the importance of dispersal processes and the data will be modelled using GIS.

**UTELLI Anna-Barbara & ROY Barbara A.**

Geobotanisches Institut ETH; Zürichbergstrasse 38; CH-8032 Zürich; Switzerland

Altitudinal variation in nectar robbery in *Aconitum lycoctonum*

Studies of nectar robbery have shown that positive, neutral and negative effects on reproduction of the plant can be found. Only few studies also considered the possible geographic variation in the plant-nectar robber interaction. We examined the causes and consequences of nectar robbery in *Aconitum lycoctonum* in high (2000 m) and low (500 m) elevation populations in

Switzerland. At high elevation, nectar robbery was more frequent and was caused by short-tongued bumblebees. A nectar robber exclusion experiment showed that nectar robbery by short-tongued bumblebees had no effect on plant female reproductive success. This result can be explained by the fact that robbing bees rarely damaged the nectaries, and piercing does not decrease flower longevity. In addition, we found that about 10% of the visits these bees made were pollen collecting. Thus, these bees may act as low efficiency pollinators and may at times be mutualistic associates, not just robbers. At low elevation, the holes in the flowers were probably caused by beetles (*Meligethes viridescens*). These beetles are mostly pollen eaters, and as such reduce plant male fitness. In addition, they damage ovaries and nectaries when feeding. Overall, our results show that there can be strong geographic variation in nectar robbery, in the nectar robber community, and the consequences of robbery for host plant fitness.

### **VIETTE Michèle, TETTAMANTI Chiara & SAUCY Francis**

Department of Biology, Ecology & Biology of Organisms; University of Fribourg; Pèrolles, CH-1700 Fribourg; Switzerland

#### *Preference for acyanogenic white clover (Trifolium repens) in the vole, Arvicola terrestris in simple and repeated choice tests*

In this paper we report investigations on the defensive role of plant secondary compounds in the reciprocal interactions between the vole, *Arvicola terrestris*, and its preferred food item *Trifolium repens*. In white clover, the production of cyanogenic glycosides (liberating HCN when the plant is attacked) is controlled by a simple genetic system involving two diallelic genes. The maintenance of a polymorphism for cyanogenesis in natural populations of white clover is poorly understood and could be explained by a selective pressure of herbivores on different cyanotypes. In this study, we conducted two series of cafeteria tests during which the voles were offered two bunches of white clover. In simple choice tests, 181 animals were tested in 13 combinations using six varieties of *T. repens* (3 acyanogenic and 3 cyanogenic). When offered opposite cyanotypes, they showed a strong preference for the acyanogenic plants, while no significant preference could be detected in tests with similar cyanotypes. However, in the latter case, they ate significantly more in tests with acyanogenic varieties. In repeated choice tests, 40 voles were tested 8 times at one or two weeks intervals for a particular choice in order to investigate the constancy of their behaviour. Again, voles showed a significant preference for acyanogenic plants and most of them showed constant choices. The consequences of these results for the maintenance of polymorphism for cyanogenesis in *T. repens* will be discussed.

### **VORBURGER Christoph & RIBI Georg**

Zoological Museum; University of Zürich; Winterthurerstrasse 190; CH-8057 Zürich; Switzerland

#### *Mechanisms of impact of the introduced crayfish Pacifastacus leniusculus on the native crayfish Austropotamobius torrentium in Switzerland*

Interspecific behavioural interactions by which the introduced North American crayfish *Pacifastacus leniusculus* could affect and possibly displace the native crayfish *Austropotamobius torrentium* in Europe were studied. We conducted a series of laboratory experiments on substrate selection, aggressive interactions and competition for shelter, and we compared size and growth between species. In choice experiments the two species differed in substrate preference with *A. torrentium* mainly selecting gravel and *P. leniusculus* mainly mud. Neither species was inherently dominant in antagonistic interactions, but dominance was size-dependent, favouring the larger and faster growing species *P. leniusculus*. Shelter possession was generally determined by aggressive dominance, although *A. torrentium* showed a stronger preference for shelters and sometimes defended them against larger *P. leniusculus*. Experimental *P. leniusculus* were infected with the crayfish plague fungus *Aphanomyces astaci*, to which they are resistant.

During the experiments, the disease was transmitted to non-resistant *A. torrentium*, which died 10 to 20 days after contact with *P. leniusculus*. We conclude that antagonistic interactions could play an important role in species replacements among crayfish by determining access to limited resources. However in the present case, a crucial factor which may promote an eventual species replacement is the crayfish plague.

### **VOUILLAMOZ José**

Institute of Ecology, Systematic Botany and Geobotany; University of Lausanne; CH-1015 Lausanne; Switzerland

The genus *Onosma* (Boraginaceae) in Switzerland: chromosome numbers, allozymic polymorphism and evolutionary history of a group of rare taxa

The genus *Onosma* is represented in Switzerland by two rare species distinguished by the numbers of rays (0-20) arising from the base of the main setae, showing distinct chromosome numbers: *O. pseudoarenaria* Schur s.l., with stellate setae (5-20 rays), and *O. helvetica* (A. DC.) Boiss. with simple setae (0-5 rays). The populations of *O. pseudoarenaria* Schur s.l. are split up and located only in Valais, between Martigny and Sierre, and show  $2n=26$  or  $2n=28$ , depending on the presence of B chromosomes. They reveal bimodal chromosomal complements with 12 large (L) and 14 or 16 small (S) chromosomes. The populations of *O. helvetica* (A. DC.) Boiss. form two poles on both sides of those of *O. pseudoarenaria* Schur s.l., one in Ollon (VD) and the other in Haut-Valais, between Sierre and Brig. They both show  $2n=20$  presenting bimodal chromosomal complements (12 L + 8 S) as well. The cytological comparison of these two species with those from Italy (*O. echioides* agg.  $2n=14$  S) and France (*O. fastigiata* s.l.  $2n=12$  L) suggests the hypotheses of an allotetraploid origin for *O. pseudoarenaria* Schur s.l. and of a hybrid origin for *O. helvetica* (A. DC.) Boiss. through back-crossing. These hypotheses are under investigation using starch gel electrophoresis to analyse the allozymic variability and try to confirm or invalidate the putative parent species. Along with the clarification of their exact karyograms, these data may allow to put forward both the origins and the postglacial recolonization routes of the genus *Onosma* in Switzerland.

### **WALTHER Gian Reto**

Geobotanisches Institut ETH; Zürichbergstrasse 38; CH-8044 Zürich; Switzerland

Why palms in Switzerland ?

The present vegetation in a given site is coupled with the local climatic and edaphic conditions. Changes in climate may also cause changes in the species composition of the vegetation. The presented study analyses possible causes of vegetation changes. Especially the spreading of exotic evergreen broad-leaved shrub and tree species points to a possible link with the changing climate in recent times.

### **WEIBEL Urs**

Geobotanisches Institut ETH & Schweiz. Vogelwarte Sempach; Zürichbergstrasse 38; CH-8044 Zürich; Switzerland

Nest site selection and breeding success of skylarks (*Alauda arvensis*) in an arable landscape with wild flower strips

Modern intensive farming regimes in Central Europe have led to severe decreases in skylark populations in the last few decades. The lack of sufficient nesting habitats throughout the breeding season due to the more frequent applications of fertilisers and a restricted crop rotation led to a reduction of the breeding attempts. Additionally, brood losses caused by farming operations, mainly mowing, led to a not sustainable breeding success. In a four year

survey of a skylark population in the Klettgau region (Canton Schaffhausen, northern Switzerland) nest site selection and breeding success was investigated. The study site (5.3 km<sup>2</sup>) is mainly used for intensive winter cereal farming, but the fields are small and wild flower strips ("Buntbrachen") are established on 6 ha. The breeding success was calculated with the May-field method. Throughout the breeding period skylarks showed a shift from winter cereals towards root vegetables as nesting sites, according to the vegetation structure. Wild flower strips, set-asides and cultivated grassland had the highest relative use as nesting habitat. Nests were more often found near to the border of the fields. The daily survival rate of eggs was significantly higher than that of nestlings. The estimated breeding success probability was about 20% between 1995 and 1997, but 38% in 1998. Broods in cereals reached the highest success probabilities, and that of nests in wild flower strips was mediocre. Nests near to the field border had a lower daily survival probability. Predation caused about 70% of all nest losses.

### **WEISSER Wolfgang W.**

Zoology Institute; University of Basel; Rheinsprung 9; CH-4051 Basel; Switzerland

#### **Predator-induced morphological shift in the pea aphid**

Aphids exhibit a polymorphism whereby individual aphids are either winged or unwinged. The winged dispersal morph is mainly responsible for the colonisation of new plants and, in many species, is produced in response to adverse environmental conditions. Aphids are attacked by a wide range of specialised predators and predation has been shown to strongly influence the growth and persistence of aphid colonies. We reared colonies of pea aphids in the presence and the absence of an adult ladybird and noted the types of morphs that were produced. Winged phenotypes first appeared in the presence of a ladybird more than one aphid generation before they were found in the control. This indicates that aphids responded to the presence of the predator by producing the dispersal morph which can escape by flight to colonise other plants. In contrast to previous examples of predator-induced defence this shift in prey morphology does not lead to better protection against predator attack, but enables aphids to leave plants when mortality risks are high.

### **ZUBER Doris & WIDMER Alex**

Geobotanisches Institut; ETH Zürich; Zollikerstrasse 107; CH-8008 Zürich; Switzerland

#### **Intraspecific phylogenetics of the European mistletoe (*Viscum album*) based on nuclear and chloroplast DNA sequences**

The European mistletoe (*Viscum album*) is a widely distributed, hemiparasitic plant species. Currently, three subspecies are recognized which differ in their host preferences. In central Europe, *V. album* ssp. *austriacum* occurs on pine (*Pinus* spp.) and rarely on Norway spruce (*Picea excelsa*); *V. album* ssp. *abietis* is restricted to silver fir (*Abies alba*), while *V. album* ssp. *album* grows exclusively on a wide variety of deciduous trees. Crossinfection experiments reported in the literature suggest that the host-parasite interaction is highly specific, although few successful crossinfections have been observed. The aim of this project was to assess phylogenetic relationships among *Viscum album* isolates from different host species to test whether molecular evidence supports the distinction of three host races and to assess their phylogenetic relationships.





## **Psélaphides paléarctiques nouveaux ou méconnus (Coleoptera: Staphylinidae: Pselaphinae)**

Claude BESUCHET

Muséum d'histoire naturelle, case postale 6434, CH-1211 Genève 6, Suisse.

**New or poorly known Palaearctic pselaphids (Coleoptera: Staphylinidae: Pselaphinae).** - One genus (*Thelotia* gen. n.) and ten new species are described: *Octomicrus deutifrons* sp. n. from Iraq, *Faronus distinctus* sp. n. from Turkey, *Thelotia cebeunica* sp. n. from France, *Amauronyx caudatus* sp. n. from Yugoslavia, *Nanunia terricola* sp. n. from Greece, *Bryaxis corsus* sp. n. from Corsica, *Trissemus bellax* sp. n. from Spain, *T. sulcifrons* sp. n. from Morocco, *T. trilobatus* sp. n. and *T. holzschuhi* sp. n. from Pakistan. Trichonychini, *Dimerus* and six species are placed in synonymy. A neotype of *Bryaxis opuntiae* Schmidt-Göbel and lectotypes of *Rybaxis marquardtii* Reitter and *Bythinus banaticus* Reitter are designated. Transfers of three species are proposed and new distributional records of *Octomicrus staphylinoides* (Fiori) are provided.

**Key-words:** Coleoptera – Staphylinidae – Pselaphinae – taxonomy – Palaearctic.

### INTRODUCTION

La collection de Psélaphides du Muséum d'histoire naturelle de Genève compte près de 180000 exemplaires préparés, dont environ 21000 pour la Suisse et 45000 pour la région paléarctique. C'est le résultat de nombreuses recherches sur le terrain, d'achats de collections, de dons importants et d'échanges. Les identifications sont plus ou moins nombreuses et complètes suivant les régions ou les tribus. Des centaines d'espèces nouvelles sont encore à décrire, particulièrement pour l'Asie où mes collègues et moi-même avons beaucoup travaillé.

Je me suis limité dans cette publication aux espèces paléarctiques, principalement pour "The Catalogue of the order Coleoptera of the Palaearctic region" où j'avais encore quelques synonymes et transferts à proposer, mais aussi des espèces nouvelles à décrire. J'ai également abordé des problèmes d'un intérêt plus général, en relation en particulier avec la valeur taxonomique attribuée à certains caractères. Je tenais à discuter depuis longtemps, exemples à l'appui, de l'écartement des hanches postérieures des Euplectini-Trichonychini et de celui des carénules du premier tergite apparent des *Trissemus*.

## ABRÉVIATIONS UTILISÉES POUR LES MUSÉES

HNHM = Hungarian Natural History Museum, Budapest

MHNG = Muséum d'histoire naturelle, Genève

## DESCRIPTIONS

**Octomicrus dentifrons** sp. n.

*Holotype* ♂. IRAQ. Misan, Azair-Qalat Salih, 14.12.1977, tamisage de détrit (Topál & Zilahy) (HNHM). *Paratypes*. Même provenance. 1 ♂ 5 ♀ (HNHM), 2 ♂ 2 ♀ (MHNG).

Long. 1,3 à 1,5 mm. Coloration entièrement d'un brun rougeâtre clair. Forme grêle, subparallèle, un peu déprimée. Tête presque carrée, un peu plus large que longue, le lobe frontal très large. Yeux bien développés, saillants, plus longs que les tempes; celles-ci arrondies. Antennes légèrement moins longues que la tête et le pronotum réunis, relativement grêles: scape cylindrique, une fois et demie plus long que large; pédicelle un peu plus long que large; articles 5 et 7 un peu plus larges que les autres articles du funicule: 3 aussi long que large, 4 à 8 transverses; massue formée de trois articles, le premier de taille intermédiaire entre les articles 8 et 10, bien séparé de ce dernier, transverse; articles 10 et 11 tout à fait contigus, de même largeur; 10 transverse, 11 deux fois plus long, légèrement plus long que large. Pronotum aussi long que large, à peine moins large que la tête; dépression basale transverse, très profonde, prolongée en avant par un sillon médian profond n'atteignant pas le bord antérieur du pronotum; côtés de celui-ci ornés chacun, en arrière, de deux petites fossettes profondes, l'une située presque sur les angles postérieurs, l'autre étant la fossette basale externe; une petite dent latérale saillante entre ces deux fossettes. Elytres réunis à peine plus longs que larges, nettement plus longs et plus larges que le pronotum; plus grande largeur située au tiers postérieur; élytres ornés chacun de deux fossettes basales profondes, d'une strie suturale entière, d'un sillon dorsal court et d'une carénule latérale très fine, entière; fossette latérale indistincte. Ailes fonctionnelles. Métasternum très convexe. Abdomen un peu moins long que toute la partie antérieure du corps, parallèle, les quatre premiers tergites apparents de même longueur, avec la même ornementation; base déclive, ornée de chaque côté d'une petite fossette profonde, prolongée sur le bord interne par une strie oblique rejoignant la suture tergite-pleurite.

Caractères sexuels du mâle. Lobe frontal prolongé en avant par une dent trapézoïdale saillante, légèrement relevée à son sommet; la base de cette dent occupe un tiers de la largeur du lobe frontal. Trochanters III armés sur le bord postérieur d'une petite dent; fémurs III un peu renflés; tibias III prolongés à l'apex par un éperon relativement robuste (fig. 1); le tiers apical du tibia porte de longues soies sur le bord interne comme sur le bord externe, supprimées sur le dessin. Les sternites apparents II, III et IV portent chacun une dépression arrondie dans la moitié postérieure du segment; sternite V orné sur son bord postérieur de deux petites dents saillantes très rapprochées, séparées par une échancrure étroite profonde; sternite VI avec une grande échancrure arrondie profonde accompagnée de part et d'autre d'une rangée de grandes soies plus ou moins régulièrement disposées; dernier sternite formé de deux hémisternites triangulaires libres (fig. 2).

Édéage (long. 0,12mm) très complexe, formé de deux parties bien distinctes (fig. 3). Partie basale (fig. 4) en position ventrale, avec deux petits paramères arrondis portant chacun trois soies et, à son sommet, deux longues épines courbées. Partie apicale (fig. 5) insérée sur le milieu de la face dorsale de la partie basale, coudée presque en angle droit par rapport à celle-ci.

*Octomicrus dentifrons* sp. n. de Mésopotamie présente des affinités évidentes avec les *Octomicrus* indo-malais, en particulier avec *O. longulus* Schaufuss, 1877, espèce-type du genre *Octomicrus* Schaufuss, 1877. Les caractères sexuels des mâles relatifs aux sternites abdominaux sont quasiment identiques. *Octomicrus dentifrons* diffère des espèces indo-malaises par les antennes plus grêles, par le lobe frontal plus large, orné chez le mâle d'une dent saillante très caractéristique et par l'édéage.

### **Octomicrus staphylinoides** (Fiori)

*Dimerus staphylinoides* Fiori, 1899

Nouvelles provenances. FRANCE, ALPES-MARITIMES: St. Jean-la-Rivière, au bord de la Vésubie, 30.05.1941 et 20.06.1958, 2 ♀ (Ochs). HAUTE-SAVOIE: Vongy-Thonon, au bord de la Dranse dans des débris de crue, 19.05.1964, 1 ♂ (Besuchet) et 12.07.1980, 1 ♂ 3 ♀ (Besuchet). SUISSE, Genève: Malval, au bord de l'Allondon dans des débris de crue, 1.04.1965, 1 ♀ (Besuchet). YÉMEN, Wadi Sharez, 03.1985, 1 ♂ (de Rougemont) (tous MHNG).

Caractères sexuels du mâle. Trochanters inermes. Avant-dernier sternite avec une grande échancrure triangulaire accompagnée de part et d'autre de soies nombreuses assez longues; dernier sternite formé de deux hémisternites triangulaires libres.

Édéage (fig. 6). Long. 0,17 à 0,19mm. Base assez longuement pédonculée. Paramères atrophiés, soudés sur la face ventrale de ce pédoncule où ils sont reconnaissables par leurs six soies. Pédoncule prolongé du côté ventral par une grande lame atténuée en pointe: cette lame porte, au milieu de sa face dorsale, une pièce complexe repliée sur elle-même, c'est-à-dire rabattue en avant. L'édéage est donc aussi formé de deux parties bien distinctes.

JEANNEL a donné deux représentations de l'édéage du *Dimerus staphylinoides* Fiori, très différentes l'une de l'autre; la première (1950: 55, fig. 21d) résulte de l'étude d'un mâle monté in toto en préparation microscopique à la gélatine glycinée; la seconde (1952a: 11, fig. 4), dessinée d'après un édéage extrait de l'abdomen, a été reprise dans une autre publication du même auteur (1956b: 93, fig. 12). J'ai pu monter en préparation microscopique au baume du Canada quatre édéages (♂♂ de France, d'Italie et du Yémen) de cette espèce, ce qui me permet d'en donner un dessin correct et une bonne interprétation, mais aussi une description précise des caractères sexuels du mâle.

*Octomicrus staphylinoides* (Fiori), 1899 (espèce-type du genre *Dimerus* Fiori, 1899) ne diffère des *Octomicrus longulus* Schaufuss, 1877 (espèce-type du genre *Octomicrus* Schaufuss, 1877) et *dentifrons* sp. n. que par quelques caractères: corps nettement déprimé; pronotum régulièrement atténué en arrière jusqu'aux angles postérieurs, sans dent latérale saillante; dépression basale du pronotum peu profonde, presque carrée, progressivement relevée en avant; pas de caractères sexuels sur les trochanters

III et les fémurs III, ni sur les sternites abdominaux II à V; édéage assez longuement pédonculé. Par contre de nombreux caractères sont tout à fait identiques: structures de la tête, du pronotum, des élytres et des tergites abdominaux; même division du dernier sternite des mâles (fig. 2); tarses de deux articles seulement (fig. 1); antennes avec les articles 5 et 7 un peu élargis; massue triarticulée, les articles 10 et 11 complètement contigus; palpes maxillaires tout à fait semblables; même réticulation du mésosternum; édéage également formé de deux parties bien distinctes. JEANNEL (1956: 84) avait déjà remarqué cette affinité étroite, mais il avait cependant maintenu *Dimerus* comme sous-genre d'*Octomicrus*. En réalité *Dimerus* Fiori, 1899 n'est qu'un synonyme d'*Octomicrus* Schaufuss, 1877 (**syn. nov.**).

### **Faronus distinctus** sp. n.

*Holotype* ♂. TURQUIE, Antalya: 18km au sud-est de Gazipasa, 27.04.1978 (Besuchet & Löbl) (MHNG). *Paratypes*. Même provenance, 1♂ 1♀ (MHNG); entre Antalya et Kemer, à 25km d'Antalya, 4.05.1975, 1♀ (Besuchet & Löbl) (MHNG); Geris près de Akseki, 23.-29.03.1997, 1♂ 1♀ (Brachat) (Coll. Brachat); env. Antalya, 1♂ (Franz) (MHNG). Mugla: Bayir, à 25km au nord-est de Kemer, 950m, 3.05.1975, 2♂ (Besuchet & Löbl) (MHNG); Gökova, 30.04.1975, 2♂ 1♀ (Besuchet & Löbl) (MHNG); Çetibeli, à 15km au nord de Marmaris, 1.05.1975, 1♂ (Besuchet & Löbl) (MHNG); 10km au nord-ouest de Mugla, 30.04.1975, 1♀ (Besuchet & Löbl) (MHNG). Izmir: Bornova, 20.05.1974, 1♀ (Jaccoud) (MHNG); Agamemnon près d'Izmir, 28.04.1975, 1♂ 2♀ (Besuchet & Löbl) (MHNG); env. Çamlık, à 14km à l'est de Selçuk, 8.05.1975, 1♂ (Besuchet & Löbl) (MHNG). GRECE, Rhodes: Mont Profitis Ilias, 600m, 24.04.1973, 1♂ (Besuchet) (MHNG). Tous dans des tamisages de mousses et de feuilles mortes.

Long. 1,6 à 2,0mm. Ne diffère extérieurement de *Faronus parallelus* Besuchet que par l'absence complète et constante des ailes, ce qui provoque quelques modifications des élytres, et par l'abdomen toujours nettement élargi de la base jusqu'au bord postérieur du 3<sup>e</sup> tergite apparent. Elytres toujours plus courts et moins larges que ceux de *F. parallelus*, élargis d'avant en arrière, le calus huméral effacé; proportion longueur/largeur chez sept exemplaires de tailles différentes: 0,37/0,45mm (♀); 0,39/0,47mm (♀); 0,40/0,48mm (♂); 0,42/0,50mm (♂); 0,43/0,49mm (♀); 0,43/0,51mm (♂); 0,44/0,53mm (♀).

Caractères sexuels. Tibias III du mâle armés sur le bord interne apical d'un petit éperon (inermes chez *parallelus*). Sclérite génital de la femelle assez robuste, en arc de cercle épais (grêle chez *parallelus*).

Édéage (long. 0,45 à 0,50mm) bien plus grand que celui de *parallelus* (0,32 à 0,36mm), mais cependant assez semblable, que ce soit au niveau des paramères ou du grand lobe falciforme; mais le second lobe de la partie médiane de l'édéage (fig. 8) diffère totalement de celui de *parallelus* (fig. 9).

Ce type d'édéage, formé dans la partie médiane de deux grands lobes bien sclérifiés, à savoir un lobe falciforme toujours semblable et un lobe portant les caractères spécifiques, existe chez trois espèces de *Faronus*.

*Faronus lafertei* Aubé, largement répandu dans l'Europe méridionale occidentale (Portugal, Espagne, France, Corse, Italie et Suisse: Genève), est normalement ailé; mais les exemplaires aptères ne sont pas rares. Les édéages sont rigoureusement sem-

blables chez les uns et les autres; c'est toujours le lobe gauche qui porte les caractères spécifiques; il n'y a donc jamais d'inversion.

*Faronus pararellus* Besuchet, largement répandu dans la région méditerranéenne orientale (Dalmatie, Grèce, Rhodes, Turquie, Chypre, Liban et Israël), est presque toujours ailé; je n'ai vu qu'un seul mâle aptère de Dalmatie. Les édéages sont toujours inversés par rapport à l'espèce précédente; c'est donc toujours le lobe droit (fig. 9) qui porte les caractères spécifiques. *Faronus sahlbergi* Besuchet (1960: 11. Holotype ♂: Mus. Helsinki. Loc. typ.: Liban, fleuve Lycus) n'est qu'un synonyme de *Faronus parallelus* Besuchet (1958: 897. Holotype ♀: Mus. Bâle, Coll. Frey. Loc. typ.: Turquie, Lyciae Taurus) (**syn. nov.**), car les deux femelles décrites sous ce dernier nom sont ailées et présentent un sclérite génital grêle.

*Faronus distinctus* n. sp., localisé dans le sud-ouest de la Turquie jusqu'à Rhodes, est toujours aptère. Les inversions de l'édéage sont fréquentes; sur 12 édéages étudiés, 4 portent les caractères spécifiques sur le lobe gauche (fig. 8) et 8 sur le lobe droit; ces inversions peuvent se manifester dans la même localité.

### **Thelotia** gen. n.

Espèce-type: *Thelotia cebennica* sp. n.

Fig. 7. Euplectini robuste, aplati, subparallèle, microphtalme et aptère. Tête avec les deux fossettes du vertex profondes, tomenteuses, largement séparées; dépression frontale bien marquée, un peu plus longue que large, prolongée de chaque côté jusqu'aux fossettes du vertex par un sillon profond. Toute la face dorsale de la tête avec de nombreux petits tubercules saillants, y compris la région oculaire et les tempes; celles-ci arrondies. Yeux réduits à quelques ommatidies. Palpes maxillaires petits. Mandibules grêles, armées d'une rangée de petites dents sur le bord interne, la partie apicale en pointe acérée. Antennes relativement courtes avec une massue de trois articles distincts. Pronotum peu convexe, plus large que long, les côtés ornés de petits tubercules saillants un peu plus gros que ceux de la tête; trois fossettes basales égales, profondes, tomenteuses, presque alignées, reliées par un sillon transversal bien marqué mais fin; pronotum orné sur toute sa longueur d'un sillon médian bien marqué, un peu moins étroit que le sillon transversal; fossettes basales latérales prolongées en arrière chacune par un sillon distinct jusqu'au bord postérieur du pronotum; encore deux fossettes tangentés à ce bord postérieur, soit une de chaque côté entre le sillon médian et les sillons latéraux. Elytres aplatis, larges et courts (de même longueur sur la suture que le pronotum); bord postérieur concave. Chaque élytre avec trois fossettes basales tomenteuses; fossette basale interne plus grande et plus profonde, formée en réalité de deux fossettes accolées à peine distinctes, prolongée par une strie suturale entière, courbée de façon à joindre la suture sur le bord postérieur de l'élytre; fossette basale médiane simple, plus petite, profonde, prolongée par une strie dorsale très courte; fossette basale latérale un peu plus grande, profonde, prolongée sur son bord externe par une carène latérale saillante sur toute la longueur de l'élytre et sur son bord postérieur par un sillon parallèle à la carène et accentuant ainsi son relief; il y a encore

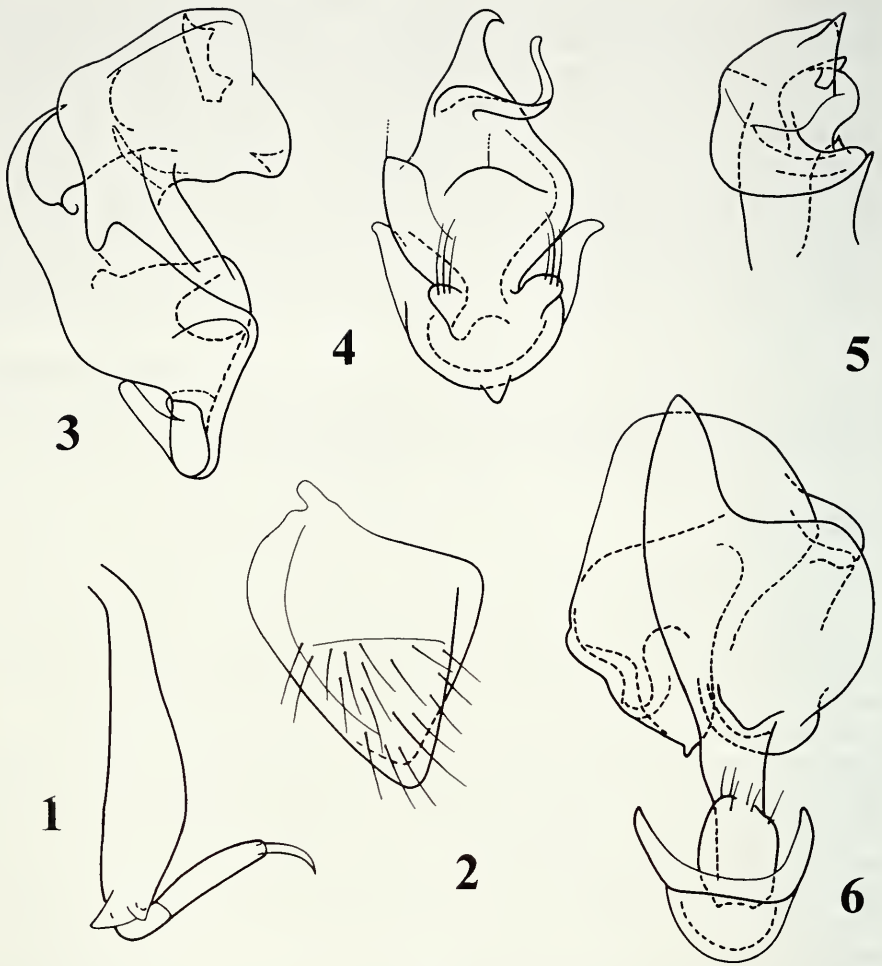

FIGS 1-6

*Octomicrus*. 1: *O. dentifrons* sp. n., tibia et tarse postérieurs du mâle; 2: Id., hémisternite du mâle, face ventrale; 3: Id., édéage, face latérale; 4 et 5: Id., partie basale et partie apicale de l'édéage au même grossissement, face ventrale: ...= points d'insertion sur la figure 4 de la partie apicale; 6: *O. staphylinoides* (Fiori), édéage, face ventrale.

une petite dent humérale saillante à côté de la fossette latérale. Abdomen plus long que le pronotum et les élytres réunis, subparallèle; premier tergite apparent nettement un peu plus long, orné à la base d'une dépression tomenteuse profonde, très courte, un peu moins large que la moitié de la largeur basale de ce segment; pas de carénules pour limiter cette dépression; tergites apparents II, III et IV de même longueur, simples, très largement rebordés sur les côtés sauf le 4<sup>e</sup> avec un rebord atténué d'avant en arrière. Pattes relativement courtes, sans caractères particuliers; tarsi terminés par un ongle

grêle assez long, simple, sans épine paronguéale. Face ventrale. Tête avec la région gulaire non carénée, suivie en arrière d'une grande fossette transverse profonde, tomenteuse. Prosternum entièrement caréné, orné de chaque côté, près du bord antérieur, d'une fossette tomenteuse profonde. Trois petites fossettes tomenteuses sur le bord antérieur du mésosternum, deux de part et d'autre de l'apophyse mésosternale, la dernière sur le bord antérieur de celle-ci. Métasternum court, orné de chaque côté de deux fossettes tomenteuses profondes, l'une sur le bord postérieur des cavités coxales II, l'autre sur le bord externe de ces mêmes cavités. Hanches I et II contiguës, III très légèrement séparées (0,04mm, soit la largeur apicale des tibias III). Premier sternite apparent avec le processus intercoxal étroit, atténué en pointe en avant; sternites apparents II, III et IV de même longueur, V de moitié plus court, le dernier un peu plus long, arrondi à l'apex; base du 2<sup>e</sup> sternite occupée toute entière par une bande tomenteuse très courte. Caractères sexuels du mâle encore inconnus.

### *Thelotia cebennica* sp. n.

*Holotype* ♀. FRANCE, GARD: Roquedur près du Vigan dans les Cévennes, 4.04.1982, dans un lavage de terre au pied d'un noisetier, dans un ravin boisé (Thelot) (MHNG).

Fig. 7. Long. 2,05mm. Coloration entièrement d'un brun rougeâtre peu foncé. Pubescence couchée, relativement courte. Face ventrale avec les téguments lisses, brillants et non ponctués. Tête un peu plus large que longue (0,33/0,38mm), avec une saillie arrondie relativement peu élevée entre les fossettes du vertex; tubercules antennaires arrondis, peu saillants, accompagnés sur leur bord postérieur d'une fossette tomenteuse, nettement plus petite et moins profonde que les fossettes du vertex. Yeux réduits à deux ou trois ommatidies dépigmentées. Longueur des antennes: 0,70mm; scape cylindrique, presque deux fois plus long que large; pédicelle légèrement moins large que le scape, un peu plus long que large; article 3 un peu plus petit, un peu plus large que long, 4 et 5 légèrement plus larges que longs, 6 et 7 très nettement plus larges que longs, l'article 7 légèrement plus large que les autres articles du funicule; 8 transverse, 9 bien plus large que les articles précédents, transverse; 10 encore plus large, transverse; dernier article (0,15/0,11mm) orné d'une grande fossette tomenteuse sur la moitié apicale de la face ventrale. Dernier article des palpes maxillaires (0,09/0,045mm) en ovale allongé. Pronotum (0,38/0,45mm) plus large que la tête, nettement plus large que long, sa plus grande largeur située au tiers antérieur, ses côtés atténués en arrière en ligne droite jusqu'aux angles postérieurs, ceux-ci obtus; disque du pronotum lisse et brillant. Elytres réunis nettement plus larges que le pronotum, nettement plus larges que longs (0,42/0,58mm avec la longueur prise sur le bord externe, 0,37/0,58mm le long de la suture). Abdomen (0,90/0,60mm au niveau du bord postérieur du 2<sup>e</sup> tergite apparent) plus long que le pronotum et les élytres réunis; longueur respective des cinq tergites apparents: 0,27mm; 0,20mm; 0,20mm; 0,20mm et 0,17mm. Longueur des tibias III: 0,40mm. Mâle encore inconnu.

Ce genre nouveau est dédié à M. Jean-Pierre Thelot de Forcalqueiret-La Roque-brussanne, qui m'a généreusement donné le seul exemplaire connu. MM J.-P. Thelot, I. Löbl, S. Vit et moi-même avons fait de gros lavages de terre dans cette région des

Cévennes méridionales pour retrouver ce Psélaphide extraordinaire. En vain malheureusement. Mais nous avons tous pris le rare *Tychobythinus lavagnei* (Deville) déjà présent dans le lavage de terre du 4.04.1982.

Chez de nombreux Psélaphides, la partie de l'élytre courbée sur le côté présente une petite fossette latérale prolongée en arrière par une carénule latérale. Chez *Thelotia*, cette fossette latérale est en position dorsale et sa carénule, particulièrement bien développée, saillante sur toute la longueur de l'élytre, forme la carène latérale. C'est l'aboutissement d'une évolution qui se manifeste déjà chez les genres *Trichonyx* Chaudoir et *Amauronyx* Reitter, où la fossette latérale est encore sur le côté de l'élytre, mais avec une carène latérale bien développée, très distincte en vue dorsale. *Thelotia* a exactement la même structure du pronotum que les *Amauronyx*, dont certaines espèces portent aussi de petites granulations sur les côtés, mais peu nombreuses. Les structures générales de la face ventrale et de l'abdomen sont aussi très semblables; mais les *Amauronyx* présentent deux carénules sur le premier tergite apparent et l'écartement des hanches III est chez eux très prononcé; leurs élytres sont toujours plus longs que le pronotum, même chez les espèces microphthalmes. A mon avis les genres *Thelotia* et *Amauronyx* sont malgré tout apparentés; mais faut-il les placer dans la tribu des Euplectini LeConte, 1861 ou dans celle des Trichonychini Reitter, 1882?

Les Trichonychini diffèrent des Euplectini, d'après RAFFRAY (1903: 489; 1908: 12, 113) et JEANNEL (1950: 72, 155; 1956a: 51) par l'écartement plus ou moins grand des hanches postérieures (contiguës chez les Euplectini) et par la structure des tarsi, formés de deux ongles inégaux (un seul ongle chez les Euplectini). PARK (1942: 63) et quelques auteurs américains avant lui avaient remarqué que cette séparation n'était pas justifiée. Je m'étais moi aussi (BESUCHET 1956: 371) opposé à cette distinction. Avec le genre *Thelotia*, le problème se pose à nouveau, avec encore plus d'acuité, car les tribus des Euplectini et des Trichonychini ont été maintenues dans le catalogue de NEWTON & CHANDLER (1989: 12, 52).

L'écartement ou la contiguïté des cavités coxales postérieures est un caractère d'une "importance majeure" selon JEANNEL (1959: 21), à tel point que les Euplectini (p. 95) et les Trichonychini (p. 460), jadis étroitement apparentés, se trouvent maintenant séparés dans deux sous-familles de JEANNEL différentes: Euplectitae et Bythininae! L'écartement plus ou moins grand des hanches postérieures est un caractère difficile à évaluer. Par contre le processus intercoxal du premier sternite apparent, qui s'intercale dans l'espace laissé libre par les hanches postérieures, permet des observations précises. Ce processus intercoxal est toujours atténué en pointe étroite chez les *Euplectus* Leach, *Biblopectus* Reitter, *Meliceria* Raffray, *Plectophloeus* Reitter, *Pseudoplectus* Reitter, *Pseudozibus* Jeannel, *Trimium* Aubé et *Thelotia*. Il est étroit, allongé, subparallèle et arrondi à son sommet chez les *Saulcyella* Reitter (Trichonychini pour JEANNEL 1950) et les *Zibus* Saulcy. Ce processus est moins étroit, trapézoïdal et un peu plus large que long chez *Aphiliops* Reitter (Trichonychini pour JEANNEL 1950). Enfin il est nettement plus large, transverse et plus ou moins arrondi à son sommet chez les *Amauronyx* Reitter, *Namunia* Reitter et *Trichonyx* Chaudoir (ces trois genres généralement placés dans les Trichonychini). Les *Thelotia* et *Amauronyx* sont complètement séparés dans ce schéma!



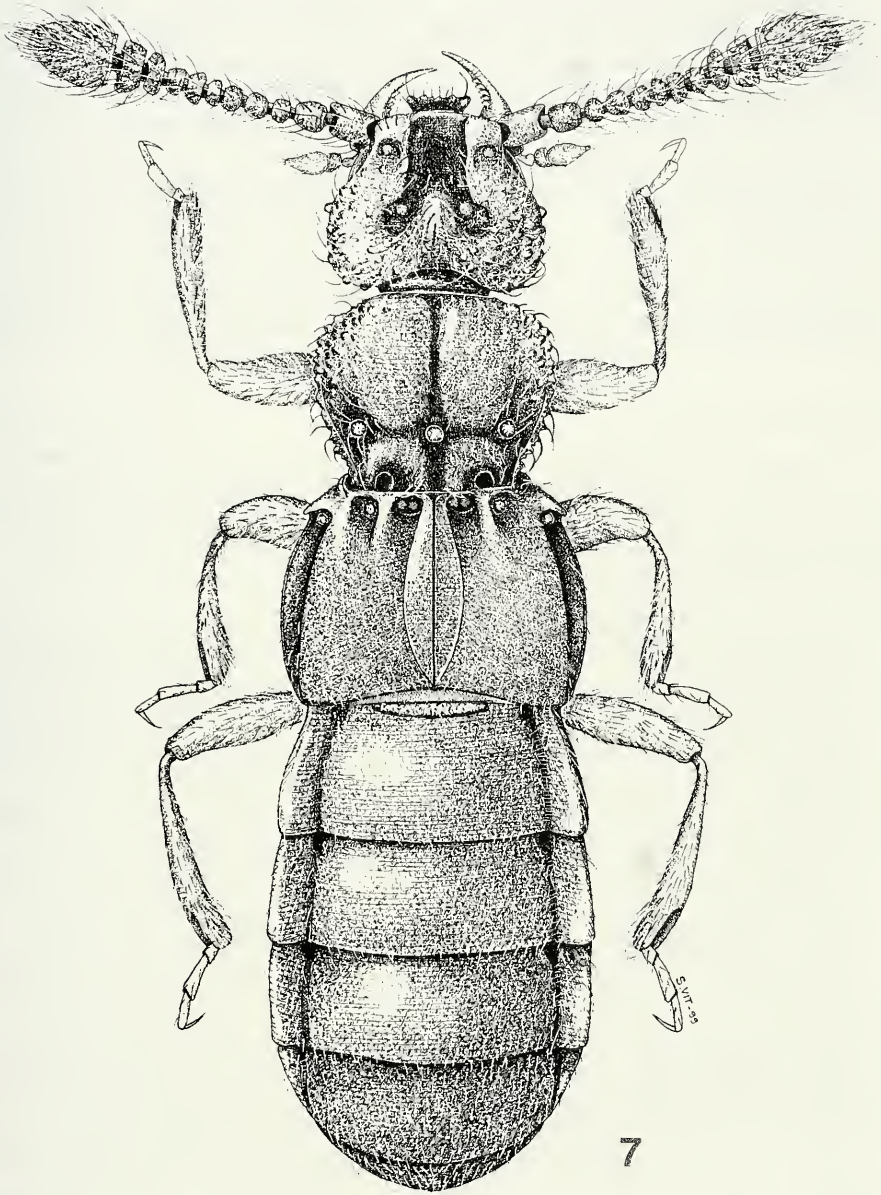

FIG. 7

*Thelotia cebennica* gen. n., sp. n., face dorsale de la femelle. Del. S. Vit.

Les *Amauronyx*, *Namunia* et *Trichonyx* présentent toujours deux ongles inégaux bien distincts. Ce deuxième ongle plus petit, inséré obliquement par rapport au premier (épine paronguéale de JEANNEL), existe également chez différents Euplectini où il a été bien observé par CASEY (1893) (in PARK 1942: 64) et par moi (BESUCHET 1956: 372). Il n'existe pas chez *Thelotia*.

JEANNEL (1950, 1956, 1959) a ajouté à la définition des Trichonychini: "élytres visiblement rebordés" ou "élytres à gouttière marginale bien visible de haut". C'est bien le cas des *Amauronyx* et des *Trichonyx*, de *Thelotia* aussi, mais pas des *Namunia*. Cette carène latérale est également bien visible chez les *Plectophloeus*! Il n'y a ainsi plus de caractères distinctifs entre les Trichonychini et les Euplectini puisque l'observation annule complètement la validité de ceux-ci. Les Trichonychini doivent donc être rattachés aux Euplectini; ils tombent dans la synonymie de ceux-ci (**syn. nov.**).

### ***Amauronyx caudatus* sp. n.**

*Holotype* ♂. YOUGOSLAVIE, Serbie, Tara Planina, Mitrovac (route Mitrovac-lac d'accumulation), 900m, 23.05.1984, tamisage de feuilles mortes dans une forêt de hêtres, érables et sapins (Besuchet) (MHNG). *Paratypes*. Même provenance, 1♂ 4♀ (Besuchet) (MHNG); Tara Planina, Mitrovac (route Perucac-Mitrovac), 950m, 23.05.1984, tamisage d'une veille souche de hêtre, 1♂ (Besuchet) (MHNG); Tara Planina, 1000m, 11.06.1984, 3♂ 4♀ (Nonveiller) (Coll. Nonveiller) et 1♂ 1♀ (MHNG).

Long. 2,2 à 2,5 mm. Coloration entièrement d'un brun rougeâtre. Pubescence couchée, formée de soies de longueur moyenne. Tête un peu plus large que longue; bosse du vertex arrondie, ornée en arrière d'une carène médiane bien marquée jusque sur la constriction collaire. Yeux petits, formés chacun de 6 à 9 ommatidies; tempes grandes, arrondies. Antennes robustes, légèrement moins longues que la tête et le pronotum réunis; scape deux fois plus long que large, distinctement rétréci à la base; pédicelle nettement plus long que large; articles du funicule de même largeur; 3 à peine ou légèrement plus long que large; 4, 6 et 7 nettement plus larges que longs ou transverses; 5 légèrement plus large ou aussi large que long; 8 transverse; massue formée de trois articles, les deux premiers transverses, le dernier deux fois plus long que les deux articles précédents réunis. Pronotum légèrement plus large que long, un peu plus large et plus long que la tête; côtés très légèrement crénelés et rebordés en arrière de la plus grande largeur, celle-ci située un peu en avant du milieu; sillon médian entier, bien marqué du bord antérieur du pronotum jusqu'à son bord postérieur; celui-ci orné de sept fossettes contiguës. Elytres réunis nettement plus larges que longs, bien plus larges et plus longs que le pronotum; calus huméral effacé; carène latérale bien visible en vue dorsale, particulièrement dans sa partie antérieure; sillon dorsal bien marqué au moins jusqu'au milieu de l'élytre. Abdomen nettement plus long que les élytres, de même largeur, terminé dans les deux sexes par une dent saillante, robuste et arrondie, entièrement localisée sur le pygidium; premier tergite apparent un peu plus grand (long. 0,25 à 0,25mm), distinctement élargi d'avant en arrière; carénules basales très courtes (0,05mm), subparallèles, largement séparées (0,20 à 0,23mm) par un espace glabre à peine approfondi. Premier sternite apparent avec un processus intercoxal transverse (largeur: 0,10mm), arrondi à son sommet.

Caractères sexuels du mâle. Tous les trochanters inermes. Tibias II prolongés sur le bord interne par un petit éperon. Méta sternum à peine déprimé dans sa partie postérieure. Avant-dernier sternite avec une grande échancrure arrondie sur le bord postérieur, sans soies ou épines particulières. Opercule légèrement plus long que large, arrondi (0,22 à 0,24/0,18 à 0,19mm).

Édage (fig. 10). Long. 0,44 à 0,45mm. Paramères avec chacun quatre soies, deux en position dorsale et deux en position ventrale; paramère droit bien développé, élargi dans sa partie apicale; paramère gauche petit, grêle, subparallèle. Lobe interne bifide dans sa moitié apicale.

*Amauronyx caudatus* sp. n. diffère de toutes les autres espèces du genre par la dent saillante de son pygidium; son édage présente une structure assez semblable à celle de l'*Amauronyx cobosi* Besuchet de l'Andalousie, mais inversée.

### **Namunia terricola** sp. n.

*Holotype* ♂. GRECE, Eubée, 5km au sud-est de Kariotos, 30.03.1983, tamisage au pied d'un platane creux (Vit) (MHNG). *Paratype*. Même provenance mais dans un tamisage de feuilles mortes, 1 ♀ (Vit) (MHNG).

Long. 2,40mm. Proche de *Namunia cavernicola* Besuchet, 1978, dont il diffère par sa taille bien plus faible, par ses antennes plus courtes (tous les articles moins allongés, spécialement les articles 9 et 10, réciproquement légèrement plus long que large et aussi long que large), par les élytres un peu plus courts, par la pubescence du méta sternum plus longue et par les trochanters II du mâle inermes mais ornés sur le bord postérieur de soies assez longues et nombreuses. C'est la partie de l'élytre courbée sur le côté qui porte la fossette latérale et la carénule latérale, cette dernière entière mais fine, totalement indistincte en vue dorsale. Les deux espèces présentent de grosses fossettes profondes et tomenteuses sur le bord postérieur des hanches II et une tomentosité abondante à la base du 2<sup>e</sup> sternite apparent, caractères que je n'avais pas relevés dans ma révision (BESUCHET, 1978: 127) et qui sont nettement moins développés chez les autres espèces du genre.

Édage (fig. 11). Long. 0,37mm (soies non comprises). Paramère droit un peu plus long que chez *N. cavernicola*; sac interne semblable, avec des centaines d'épines minuscules serrées.

Quelques mensurations de l'holotype de *Namunia terricola* sp. n. Tête, longueur/largeur: 0,49/0,45mm; lobe frontal, largeur: 0,28mm; scape: 0,20/0,09mm; pronotum: 0,48/0,50mm; élytres: 0,63/0,82mm (longueur prise sur la suture); soies des élytres, longueur: 0,17-0,19mm; premier tergite apparent: 0,37/0,82mm; processus intercoxal, largeur apicale: 0,16mm; tibias III, longueur: 0,68mm.

### **Bryaxis corsus** sp. n.

*Holotype* ♂ homéomorphe. FRANCE, CORSE: Haut Asco, 3.06.1971 (Senglet) (MHNG). *Paratypes*. Même provenance, 3 ♂ hom. 8 ♀ (Senglet) (MHNG); Haut Asco, 1500m, 10.07.1974, 1 ♂ hom. (Löbl) (MHNG); Haut Asco, 1450m, 17.08.1981, 4 ♂ hom. (Brachat) (Coll. Brachat); 1500m, 31.05.1986, 1 ♂ hom. 5 ♀ (Brachat) (Coll. Brachat); Forêt de Bonifato, 700m, 04.1976, 1 ♂ hom. 1 ♀ (Deharveng) (MHNG); Forêt de Tartagine, 04.1976, 1 ♂ oed. 1 ♂ hom. 1 ♀ (Deharveng) (MHNG).

Long. 1,35 à 1,65mm. Coloration d'un brun rougeâtre clair. Tête légèrement plus large que longue, le tégument lisse et brillant; lobe frontal subparallèle, transverse, tronqué en avant, orné d'une dépression bien marquée; carène du vertex entière, normalement développée, égale sur toute la longueur. Yeux plutôt petits, formés de 5 à 7 ommatidies chez la femelle, de 7 à 9 chez le mâle. Tempes arrondies en vue dorsale, distinctement anguleuses sous les yeux, cet angle prolongé par quelques soies. Palpes maxillaires normalement développés, avec quelques granules écrasés dans la partie apicale du 2<sup>e</sup> article; dernier article deux fois et demie plus long que large, la plus grande largeur située au tiers basal. Antennes à peine moins longues que la tête et le pronotum réunis; article 3 très nettement plus long que large, 4 et 5 égaux, un peu plus longs que larges, 6 et 7 sphériques, 8 un peu plus large que long; massue formée de trois articles progressivement élargis, les deux premiers transverses, le dernier aussi long que les quatre articles précédents réunis. Pronotum aussi long que large, le tégument lisse, brillant, non ponctué; plus grande largeur située un peu en avant du milieu. Elytres réunis un peu plus larges que longs, la ponctuation légère, éparse; calus huméral effacé.

Caractères sexuels de la femelle. Scape simple, cylindrique, deux fois plus long que large; pédicelle simple, une fois et demie plus long que large. Tibias I et III simples, grêles.

Caractères sexuels des mâles. Scape (fig. 12) fortement renflé, orné au milieu de son bord interne d'un gros tubercule arrondi mais aplati dorso-ventralement; pédicelle (fig. 12) un peu plus long que large, assez largement rebordé sur son bord interne, l'angle apical saillant. Mâle homéomorphe avec les fémurs non renflés, les tibias I grêles mais nettement échancrés au tiers apical, les tibias III grêles, simples et légèrement courbés près de l'apex. Mâle oedimère plus robuste, le pronotum légèrement plus large, les fémurs fortement renflés, les tibias I un peu plus robustes, aussi nettement échancrés au tiers apical; tibias III robustes, armés d'une petite dent saillante un peu en arrière du milieu du bord interne; partie apicale du tibia moins large, le bord interne légèrement concave, prolongé à l'apex par un éperon bien distinct.

Edéage (fig. 13) parfaitement symétrique. Long. 0,33 à 0,34mm chez les mâles homéomorphes, 0,37mm chez le mâle oedimère. Paramères parallèles dans la partie apicale chez les mâles homéomorphes, assez régulièrement atténués chez le mâle oedimère. Lobe interne grêle, subparallèle, simple dans sa partie basale, bilobé dans sa partie apicale.

Il y a des *Bryaxis* endémiques dans presque tous les massifs montagneux de la région méditerranéenne; ce genre n'était pourtant pas encore connu des montagnes de la Corse. Ce *Bryaxis corsus* sp. n. est apparenté au *Bryaxis pedator* (Reitter) de l'Italie moyenne par le scape antennaire du mâle, par les tibias postérieurs du mâle oedimère et par la structure générale de l'édéage. Mais il en diffère par les yeux distinctement plus petits et par les tempes anguleuses dans les deux sexes, par le pédicelle antennaire du mâle fortement dilaté et assez largement rebordé sur le bord interne (fig. 12) (chez *B. pedator*, pédicelle petit, simple, semblable à celui de la femelle), enfin par l'édéage dont les paramères sont inermes et le lobe interne moins franchement bilobé.

**Trissemus bellax** sp. n.

*Holotype* ♂. ESPAGNE, Prov. CIUDAD REAL: Venta de Cardenas, 16.05.1960, dans le gravier au bord du Rio Magaña (Besuchet) (MHNG). *Paratypes*. Même provenance, 1 ♂ (MHNG). Prov. CIUDAD REAL: Ojos del Guadiana, 14.08.1969, 3 ♂ (Senglet) (MHNG). Prov. JAEN: Hinojarez, 19.07.1971, 1 ♂ (Senglet) (MHNG). Prov. ZARAGOZA: Caspe, 28.09.1966, dans un marais (Comellini) (MHNG).

Long. 1,6 à 1,8mm. Coloration d'un brun rougeâtre plus ou moins foncé. Teguments de la face dorsale non ponctués, lisses et brillants, avec une pubescence couchée, formée de soies courtes. Tête un peu plus large que longue; face dorsale légèrement convexe, ornée de trois fossettes profondes, tomenteuses, la fossette frontale étant légèrement plus grande; lobe frontal court, transverse, atténué d'arrière en avant; tempes subparallèles en arrière des yeux, puis atténuées et arrondies, un peu plus courtes que ceux-ci. Antennes de longueur moyenne; scape et pédicelle nettement plus longs que larges; article 3 à 6 de même largeur, un peu moins larges que le pédicelle; 3, 5 et 6 nettement plus longs que larges, 4 légèrement ou un peu plus long que large. Pronotum un peu plus large que long, un peu plus large que la tête, la plus grande largeur située un peu en avant du milieu; côtés fortement arrondis, subparallèles près des angles postérieurs; fossette basale médiane petite et profonde; base du pronotum ornée sur toute la largeur de petits points serrés. Elytres réunis nettement plus larges que longs, deux fois plus larges que la tête, la plus grande largeur située un peu en avant de l'apex; callosité humérale assez bien marquée, arrondie; strie dorsale interrompue un peu avant le bord postérieur des élytres. Ailes bien développées. Premier tergite apparent (0,28-0,31/0,70-0,75mm) légèrement atténué d'avant en arrière; carénules basales légèrement divergentes, courtes, marquées tout au plus jusqu'au tiers antérieur du tergite, séparées à la base par un espace (0,21-0,22mm) un peu inférieur au tiers de la largeur basale du segment.

Caractères sexuels de la femelle. Articles 7 et 8 des antennes de même largeur que les articles précédents, 7 nettement un peu plus large que long, 8 transverse; massue triarticulée, progressivement élargie; article 9 transverse, 10 un peu plus large que long; dernier article relativement petit (0,15/0,10mm), la base obliquement tronquée.

Caractères sexuels du mâle. Massue antennaire formée de cinq articles; articles 7 et 8 un peu plus larges que les articles précédents, 7 transverse, 8 très transverse; article 9 nettement plus large, très transverse, un peu déprimé sur la face ventrale; article 10 très grand (0,16-0,17/0,14mm), obliquement tronqué à l'apex, convexe sur la face dorsale, déprimé sur la face ventrale de la base au quart apical; cette dépression ornée de deux sillons longitudinaux profonds, contigus; quart apical ventral avec deux petites dents saillantes; dernier article petit (0,15-0,16/0,10-0,11mm) comme chez la femelle, la base aussi obliquement tronquée. Trochanters simples; hanches II armées chacune, à la base, d'une dent aiguë robuste; tibias II armés sur le bord interne, juste avant l'apex, d'un éperon grêle pointu. Dépression du métasternum peu profonde.

Edéage (fig. 14). Long. 0,33 à 0,36mm. Paramères convergents fortement d'avant en arrière, prolongés chacun par une petite lame apicale subparallèle, ces deux lames contiguës. Armature du sac interne formée d'une grande épine et d'une douzaine d'épines grêles séparées en deux faisceaux.

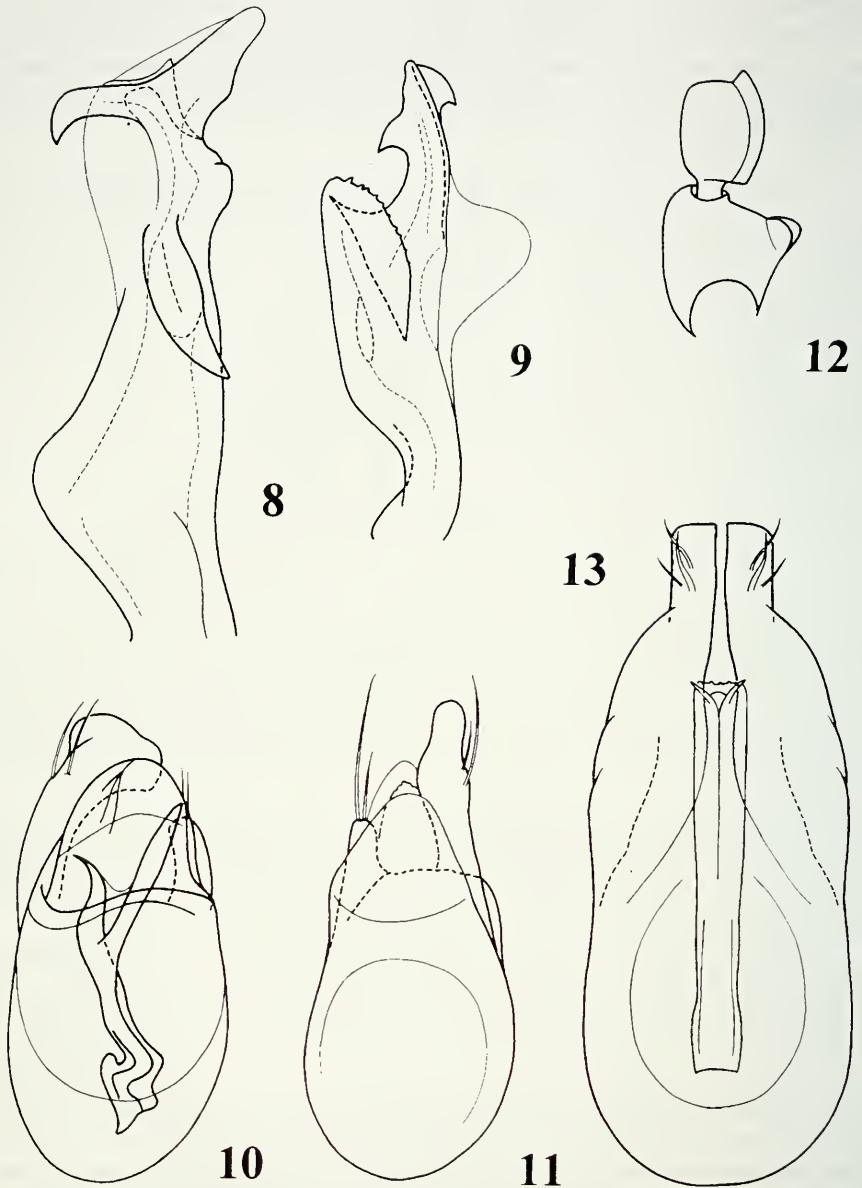

FIGS 8-13

8: *Faronus distinctus* sp. n., lobe de l'édéage portant les caractères spécifiques, face dorsale; 9: *Faronus parallelus* Besuchet, id., face dorsale au même grossissement; 10: *Amauronyx candatus* sp. n., édéage, face dorsale; 11: *Namniia terricola* sp. n., édéage, face dorsale; 12 et 13: *Bryaxis corsus* sp. n., base de l'antenne du mâle, face dorsale et édéage du mâle homéomorphe, face dorsale.

Les *Trissemus antennatus* (Aubé), *heterocerus* (Aubé) et *bellax* sp. n. sont nettement apparentés par la grande massue antennaire des mâles mais cependant bien distincts les uns des autres par la structure de cette massue.

***Trissemus sulcifrons* sp. n.**

*Holotype* ♂. MAROC, environs de Rabat, 03.1963, dans des débris accumulés par une crue (Mussard) (MHNG).

Long. 1,8mm. Coloration d'un brun noirâtre, les élytres rougeâtres. Espèce très proche et très semblable à *Trissemus quedenfeldti* (Reitter) dont elle diffère par les antennes plus courtes, par les caractères sexuels du front et des antennes plus marqués et par l'édéage. Tête aussi longue que large, le lobe frontal très large (0,33mm), fortement transverse; tubercules antennaires aplatis; épistome rugueux; fossettes du vertex petites, profondes, tomenteuses, séparées par un espace convexe (0,19mm) presque double de celui qui se trouve entre le bord supérieur de l'œil et la fossette voisine. Antennes un peu plus longues que la tête et le pronotum réunis; scape court, à peine plus long que large; pédicelle petit, légèrement plus long que large; article 3 long, modifié chez le mâle; articles 4 à 8 de même largeur, un peu moins larges que le pédicelle; 4 un peu plus long que large, 5 une fois et demie plus long que large, 6 légèrement plus long que 4 mais moins long que 5; article 7 à peine plus long que large, 8 transverse; massue triarticulée, progressivement élargie; article 9 nettement plus large que long, 10 un peu plus large que long; dernier article (0,18/0,11mm) un peu asymétrique, la face dorsale nettement plus convexe, la base obliquement tronquée. Premier tergite apparent (0,33/0,73mm) atténué d'avant en arrière; carénules basales nettement divergentes, marquées presque jusqu'au milieu du tergite, séparées à la base par un espace (0,10mm) égal à 1/7 de la largeur basale du segment.

Caractères sexuels du mâle. Base du lobe frontal limitée par un sillon profond en arc d'accolade, la pointe dirigée en arrière, les extrémités atteignant presque le bord latéral; lobe frontal légèrement surélevé au milieu, orné près du sillon d'une très petite carène médiane partiellement masquée par une touffe de soies serrées. Antennes avec l'article 3 particulièrement grand (0,125/0,07mm), aussi long que les articles 4 et 5 réunis, un peu plus large que le pédicelle, distinctement élargi de la base à l'apex, la face externe nettement convexe, la face interne distinctement concave avec de très petits granules serrés. Tous les trochanters simples; tibias II prolongés à l'apex du bord interne par un éperon robuste. Dépression du métasternum peu profonde. Chez *T. quedenfeldti*, le sillon frontal est moins profond, simplement un peu courbé; l'article 3 des antennes est aussi très allongé mais à peine modifié.

Édéage (fig. 15). Long. 0,36mm. Diffère de celui de *T. quedenfeldti* (fig. 16) (0,43 à 0,48mm) par les paramères de largeur plus égale et les dents du sac interne plus courtes.

***Trissemus trilobatus* sp. n.**

*Holotype* ♂. PAKISTAN, Prov. Swat: Madyan, 1400m, 19.06.-4.07.1971, à la lumière (Holzschuh) (MHNG). *Paratypes*. Même provenance, 47 ♂ 1 ♀ (MHNG), 50 ♂ (Coll. Holzschuh).

Long. 1,55 à 1,7mm. Coloration entièrement d'un brun rougeâtre peu foncé. Téguments de la face dorsale non ponctués, lisses et brillants, avec une pubescence couchée, formée de soies courtes. Tête légèrement plus large que longue; face dorsale un peu convexe, ornée de trois fossettes profondes, tomenteuses, égales; lobe frontal court, transverse, un peu atténué d'arrière en avant; tempes atténuées dès le bord postérieur des yeux, arrondies, un peu plus courtes que ceux-ci. Antennes légèrement plus longues que la tête et le pronotum réunis chez le mâle, un peu plus courtes chez la femelle; scape une fois et demie plus long que large; pédicelle nettement plus long que large; articles 3 à 7 de même largeur, un peu moins larges que le pédicelle; 3, 4 et 5 nettement plus longs que larges, 4 et 5 souvent très légèrement plus courts; article 6 légèrement ou à peine plus long que large, 7 transverse. Pronotum un peu plus large que long, légèrement plus large que la tête, la plus grande largeur située au milieu; côtés fortement arrondis et atténués jusqu'à la base; fossette basale médiane petite, profonde; base du pronotum ornée sur toute la largeur de petits points serrés. Elytres réunis nettement plus larges que longs, presque deux fois plus larges que la tête, la plus grande largeur située un peu en avant de l'apex; callosité humérale assez bien marquée, arrondie; strie dorsale interrompue un peu avant le bord postérieur des élytres. Ailes bien développées. Premier tergite apparent (0,32-0,35/0,69-0,72mm) légèrement atténué d'avant en arrière; carénules basales nettement divergentes, assez longues, dépassant légèrement le milieu du tergite, séparées à la base par un espace (0,17-0,19mm) égal environ au quart de la largeur basale du segment.

Caractères sexuels de la femelle. Article 8 des antennes de même largeur que les articles précédents, très transverse; massue triarticulée, progressivement élargie; articles 9 et 10 transverses; dernier article relativement petit (0,18/0,11mm), la base obliquement tronquée.

Caractères sexuels du mâle. Article 8 des antennes légèrement plus large que les articles précédents, un peu prolongé du côté ventral; massue triarticulée (fig. 17); article 9 transverse, échancré au milieu de sa face ventrale; article 10 transverse, prolongé sur sa face ventrale par trois lobes allongés (fig. 18); dernier article assez grand (0,24-0,26/0,15mm), la base formée, du côté ventral, par une lame portant un petit lobe arrondi de chaque côté et une lamelle trapézoïdale au milieu; cette lame est immédiatement suivie d'une cavité transverse très profonde qui se prolonge, sur la face ventrale de cet article 11, par une dépression progressivement atténuée en profondeur et en largeur. Trochanters II ornés, sur le bord postérieur, d'une épine très fine; tibias II armés sur le bord interne, un peu avant l'apex, d'un éperon très long (fig. 19), sub-parallèle et tronqué à son extrémité. Dépression du métasternum peu profonde.

Édage (fig. 20). Long. 0,40 à 0,43mm. Paramères élargis dans la partie apicale. Armature du sac interne formée de 12 à 14 épines assez grandes.

*Trissemus trilobatus* sp. n. est proche de *T. akinini* (Reitter) de l'Asie centrale tant par la massue antennaire du mâle que par l'édage, presque semblable; les tibias II portent aussi un éperon très long, tronqué chez *trilobatus*, atténué en pointe chez *akinini*. Ce dernier présente chez le mâle un net renflement des articles antennaires 4, 5 et 6 tandis que la massue du mâle de *trilobatus* est d'une complexité bien plus grande (fig. 17).



**Trissemus holzschuhi** sp. n.

*Holotype* ♂. PAKISTAN, Prov. Swat: Madyan, 1400m, 19.06.-4.07.1971, à la lumière (Holzschuh) (MHNG).

Long. 1,6mm. Coloration entièrement d'un brun rougeâtre peu foncé. Téguments de la face dorsale non ponctués, lisses et brillants, avec une pubescence couchée formée de soies courtes. Tête à peine plus large que longue; face dorsale légèrement convexe, ornée de trois fossettes profondes, tomenteuses, la fossette frontale étant un peu plus grande; lobe frontal court, transverse, ses côtés presque parallèles; tempes atténuées dès le bord postérieur des yeux, arrondies, un peu plus courtes que ceux-ci. Antennes aussi longues que la tête et le pronotum réunis; scape et pédicelle nettement plus longs que larges; articles du funicule de même largeur, nettement moins larges que le pédicelle; article 3 presque deux fois plus long que large, 4 et 6 nettement plus longs que larges, 5 une fois et demie plus long que large, 7 légèrement plus long que large, 8 distinctement plus large que long; massue triarticulée, progressivement élargie; article 9 un peu plus large seulement que les articles précédents, un peu plus large que long, 10 nettement plus large que long; dernier article relativement petit (0,15/0,09mm), un peu plus convexe sur la face dorsale. Pronotum un peu plus large que long, un peu plus large que la tête, la plus grande largeur située un peu en avant du milieu; côtés fortement arrondis, subparallèles près des angles postérieurs; fossette basale médiane petite, profonde; base du pronotum ornée sur toute la largeur de petits points serrés. Elytres réunis nettement plus larges que longs, presque deux fois plus larges que la tête, la plus grande largeur située un peu en avant de l'apex; callosité humérale assez bien marquée, arrondie; strie dorsale distincte presque jusqu'au bord postérieur des élytres. Ailes bien développées. Premier tergite apparent (0,28/0,66mm) légèrement atténué d'avant en arrière; carénules basales à peine divergentes, assez longues (0,16mm), marquées jusqu'au tiers postérieur du tergite, largement séparées (0,26mm) par un espace égal aux 2/5 de la largeur basale du segment.

Caractères sexuels du mâle. Antennes non modifiées. Trochanters II légèrement anguleux sur la base du bord postérieur; tibias II prolongés sur le bord interne par un éperon robuste, tibias III par un petit éperon grêle. Disque du métasternum occupé par une dépression arrondie très profonde.

Édéage (fig. 21). Long. 0,34mm. Paramères complètement soudés dans la partie médiane, courts mais bien séparés dans la partie apicale. Armature du sac interne complexe, avec en position dorsale un faisceau de nombreuses soies très longues et en position ventrale deux slérites de chaque côté.

*Trissemus holzschuhi* sp. n. n'a pas d'affinités directes avec les autres espèces paléarctiques du genre. Il est bien caractérisé par les carénules du premier tergite apparent largement séparées et par l'édéage dont les paramères sont complètement soudés dans la partie médiane et l'armature du sac interne formée de soies nombreuses.

D'après JEANNEL (1959:529), les *Trissemus* paléarctiques se répartissent dans trois sous-genres: *Trissemus* Jeannel s. str. pour les *T. antennatus* (Aubé) et *heterocerus* (Aubé); *Trissemellus* Jeannel pour les *T. maroccanus* (Raffray), *arabicus* (Raffray), *brittoni* Jeannel; *Trissemosus* Jeannel pour les *T. niloticus* (Motschulsky) et *tetuanicus*

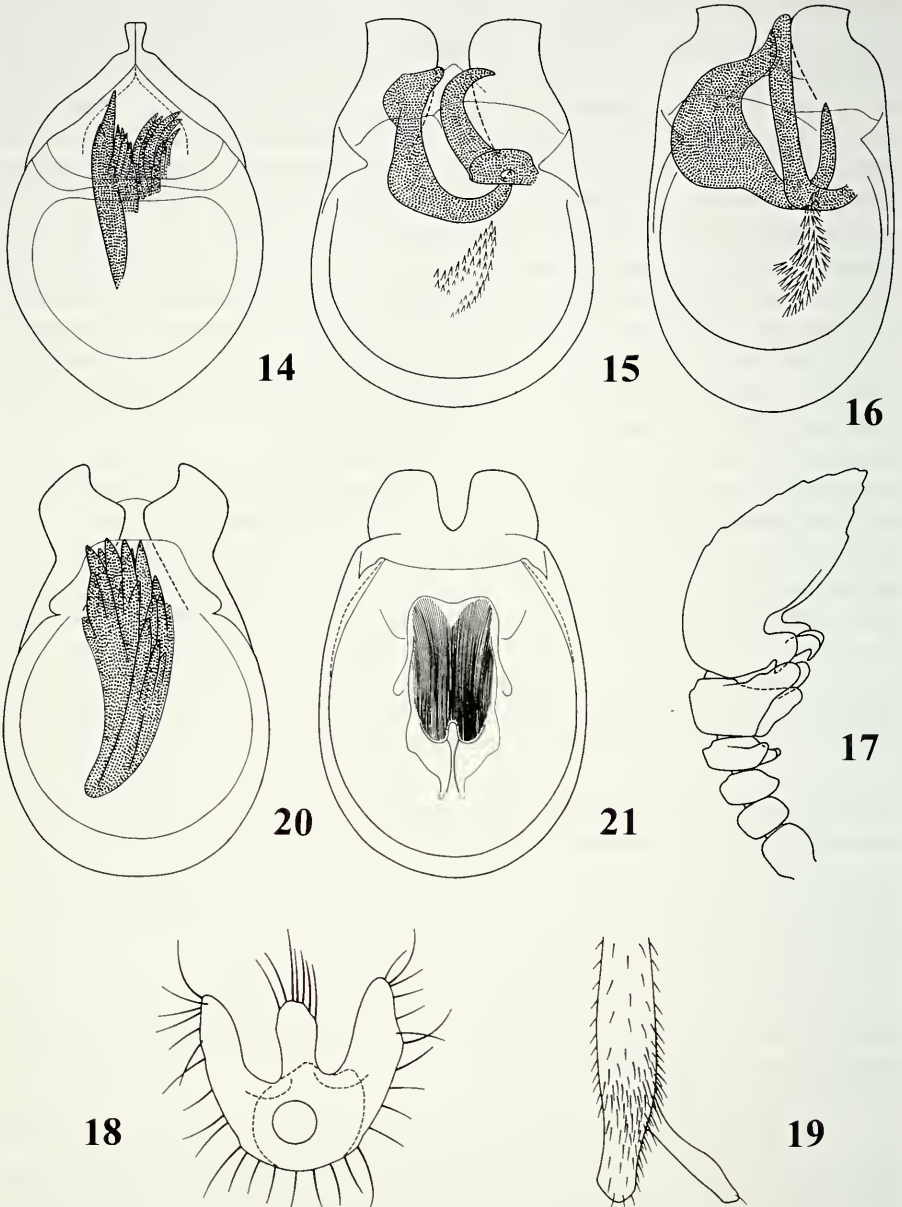

FIGS 14-21

*Trissemus*. 14: *T. bellax* sp. n., édéage, face dorsale; 15: *T. sulcifrons* sp. n., édéage, face dorsale; 16: *T. quedenfeldti* (Reitter), édéage, face dorsale; 17: *T. trilobatus* sp. n., extrémité de l'antenne du mâle, face latérale; 18: Id., article 10 de l'antenne du mâle, vue de bout; 19: Id., extrémité du tibia intermédiaire du mâle; 20: Id., édéage, face dorsale; 21: *T. holzschuhi* sp. n., édéage, face dorsale.

Jeannel, auxquels il faut encore ajouter *Trissemites* Jeannel pour *T. militaris* (Saulcy) d'après son tableau d'identification. Celui-ci est basé principalement sur l'écartement plus ou moins grand des carénules basales du premier tergite apparent, la localisation des caractères sexuels sur les antennes et quelques structures de l'édéage.

Le sous-genre *Trissemus* s. str. est bien défini, selon JEANNEL, par la grande massue antennaire du mâle et par l'édéage avec les paramères soudés. *Trissemus bellax* sp. n. présente une massue antennaire assez semblable à celle de *T. antennatus* (Aubé), espèce-type du genre *Trissemus*; mais ses paramères (fig. 14) sont indépendants, contigus seulement dans la partie tout à fait apicale. Toujours d'après JEANNEL, le sous-genre *Trissemites* présente des carénules distantes du quart ou du cinquième de la largeur du tergite, avec des antennes semblables dans les deux sexes. C'est bien le cas pour *T. militaris* (Saulcy). Mais que penser du *T. trilobatus* sp. n., *Trissemites* par ses carénules du premier tergite apparent, mais totalement différent par la massue antennaire du mâle (fig. 17)? Enfin *T. holzschuhi* sp. n., d'après ce même tableau d'identification, serait un *Trissemellus*, mais dont les paramères de l'édéage sont soudés (fig. 21). La valeur taxonomique des caractères retenus par JEANNEL pour les *Trissemus* me paraît bien discutable. L'écartement des carénules de ce premier tergite apparent est sujet à une certaine variation intraspécifique; il y a d'autre part, à l'intérieur du genre, tous les intermédiaires entre les écartements minimum (1/7) et maximum (2/5). Quant aux caractères sexuels des antennes, ils peuvent concerner, suivant les espèces, tous les articles (sauf le scape), un ou plusieurs à la fois. L'édéage présente normalement deux paramères bien séparés, indépendants; mais ceux-ci peuvent être exceptionnellement contigus ou soudés, sur des longueurs plus ou moins grandes.

Les caractères appliqués pour les sous-genres des *Trissemus* sont par trop variables et arbitraires; ils sont sans intérêt pour les espèces paléarctiques et ne peuvent pas être retenus. Par conséquent je transfère toutes les espèces paléarctiques, y compris celles du Japon, dans le sous-genre *Trissemus* s. str.

## NOUVEAUX SYNONYMES ET TRANSFERTS

*Rybaxis marquardtii* Reitter (1900: 50. Syntype ♂ ici désigné comme lectotype: Mus. Paris. Loc. typ.: Ouzbékistan: Buchara) n'est qu'un synonyme de *Rybaxis longicornis* (Leach, 1817) (**syn. nov.**). Ce lectotype appartient à la forme ♂ *longicornis* s. str.

*Pselaphus ruber* Beck (1817: 10, pl. II, fig. 7. Types perdus. Loc. typ.: Allemagne, Bavière) est d'après la description un synonyme de *Rybaxis longicornis* (Leach, 1817) (**syn. nov.**).

*Pselaphus castaneus* Beck (1817: 11, pl. II, fig. 9. Types perdus. Loc. typ.: Allemagne, Bavière) est d'après la description un synonyme de *Brachygluta fossulata* (Reichenbach, 1816) (**syn. nov.**).

*Trissemus sahlbergi* Karaman (1963: 79, fig. 1, 2 et 3. Holotype ♂: Mus. Budapest. Loc. typ.: Palestine, Jourdain) n'est qu'un synonyme de *Trissemus dentipes* (Baudi, 1869) (**syn. nov.**). Je connais cette espèce de Chypre, du sud-est de la Turquie, d'Israël et de Jordanie.

Le genre *Kunzea* Leach (1826: 448) est souvent cité dans les catalogues et les bibliographies comme synonyme de *Bryaxis* Kugelann, 1794 = *Arcopagus* Leach, 1817 = *Bythinius* auct.; mais l'espèce-type *nigriceps* Leach (1826: 449) a toujours été oubliée par les auteurs. Les diagnoses données en latin et en anglais sont pourtant assez précises, en particulier pour les antennes; d'autre part l'espèce a été découverte dans une forêt de pins des Alpes-Maritimes françaises. Seul *Bryaxis latebrosus* (Reitter), pas rare dans le sud-est de la France et en Ligurie occidentale, correspond aux descriptions de Leach: "Antennae with their first and second joints thicker than the others; the first elongato-cylindric, internally abruptly dilated; the second minutely globose, narrower than the first one"... "Corpore toto ferruginea".

D'autre part on peut éliminer les espèces décrites précédemment par LEACH (1817: 83), à savoir "*Bythinius securiger*", "*Bythinius Curtisii*", "*Arcopagus glabri-collis*", "*Arcopagus clavicornis*" et "*Arcopagus bulbifer*", de même "*Arcopagus rugi-collis*", décrit en 1826. *Kunzea nigriceps* Leach (1826: 449. Types perdus semble-t-il. Loc. typ.: France, Alpes-Maritimes) et *Bythinius latebrosus* Reitter (1884: 72. Syntypes ♂: Mus. Paris. Loc. Typ.: France, Alpes-Maritimes: Nice) sont synonymes (**syn. nov.**) dans le genre *Bryaxis* Kugelann.

*Linderia* (s. str.) *leleupi* Jeannel (1952b: 292). Holotype ♀: Inst. Bruxelles. Loc. typ.: France, Ariège: Saint-Girons) appartient en réalité au genre *Bryaxis* Kugelann (**comb. nov.**) et plus précisément au groupe de *B. fauconueti* (Fauvel). Coiffait a retrouvé cette espèce dans différentes localités de l'Ariège; les femelles sont tout à fait semblables à l'holotype de *B. leleupi*; les mâles sont fortement oedimères, avec des yeux formés d'une dizaine d'ommatidies et un scape subcylindrique deux fois et demie plus long que large, simple; pédicelle un peu plus long que large, simple.

*Macroblythius klimeschi* W. & C. Blattný (1914: 175. Lectotype ♂: Mus. Bâle, Coll. Frey. Loc. typ.: Croatie, Dalmatie centrale, Svilaja Planina) appartient indiscutablement au genre *Bryaxis* Kugelann (**comb. nov.**). Il est bien difficile de préciser les affinités de cette espèce endogée, car ce lectotype, étiqueté en 1956 par un M. Kamp., n'a pas d'édéage. Je juge utile de compléter la description des frères Blattný par quelques mensurations.

Long. 1,70mm. Yeux formés chacun de 3 à 4 ommatidies dépigmentées, saillantes. Tête: 0,33/0,35mm, yeux compris; largeur du lobe frontal: 0,20mm. Pronotum: 0,41/0,43mm. Elytres réunis: 0,66/0,73mm. Antennes, long. 0,94mm; scape: 0,25/0,08mm, légèrement élargi de la base à l'apex; pédicelle: 0,08/0,06mm; article 11: 0,19/0,10mm. Dernier article des palpes maxillaires: 0,30/0,10mm. Tibias III grêles: 0,62/0,05mm. Carène du vertex entière, bien marquée sur toute sa longueur, légèrement surélevée en avant et en arrière.

*Bythinius bauaticus* Reitter (1884: 74. Syntype ♂ ici désigné comme lectotype: Mus. Paris. Loc. typ.: Roumanie, Mehadia) est effectivement un synonyme de *Bythinius hopfgarteni* Reitter, 1881, comme l'a montré KARAMAN (1948: 11, 16). Mais la variabilité du 2<sup>e</sup> article antennaire des mâles est mal interprétée. *B. hopfgarteni* et *bauaticus* ont quasiment le même pédicelle, correspondant à la fig. 1i de KARAMAN ("*B. hopf.* ab. *rectangulus* ♂"); la fig. 1h ("*B. hopf.* ab. *bauaticus* ♂") et la fig. 1g ("*B. hopfgarteni*

♂”) représentent d’autres stades de cette variabilité, toujours fréquente chez les mâles des *Bythinus* balkaniques.

*Tychus fournieri* Saulcy (1864: 259. Syntypes: Mus. Paris. Loc. typ.: France, Var: Draguignan) a été déplacé par JEANNEL (1960: 344) dans le genre *Tychomorphus* Jeannel. Il appartient en réalité au genre *Tychus* Leach (**comb. nov.**) où il est apparenté à *Tychus aretinus* Doderò.

*Bryaxis opuntiae* Schmidt-Göbel (1836: 31, pl. I fig. 17. Type ♂ perdu. Loc. typ.: Italie, Sicile). MACHULKA (1930: 120) a fait remarquer le premier que ce *Bryaxis opuntiae* de Sicile est un Tychini et que le *Bryaxis opuntiae* sensu AUBÉ (1844: 115) est identique au *Reichenbachia opuntiae* auct., aujourd’hui *Trissemus olivieri* (Raffray). SCHMIDT-GÖBEL (1836) a décrit deux Tychini de Sicile, l’un au front étroit (*Tychus dichrous*, p. 18, fig. 16), l’autre au front large (*Bryaxis opuntiae*, p. 31, fig. 17); les types sont perdus pour les deux espèces. Les Psélaphides de la collection Schmidt-Göbel ne se trouvent pas au musée de Prague; *B. opuntiae*, découvert en Sicile par Helfer, n’existe pas dans la collection de celui-ci, conservée au musée de Prague (communication du Dr J. Jelinek), ni d’ailleurs dans la collection Motschulsky à Moscou, où se trouvent aussi des Psélaphides de Helfer.

La faune des Psélaphides de la Sicile est maintenant bien connue grâce à SABELLA (1998); celui-ci fait d’ailleurs correctement remarquer que les *Tychomorphus* qui peuplent cette île, *T. jacquelinei* (Boieldieu, 1859) et *integer* (Reitter, 1881), pourraient correspondre à *Bryaxis opuntiae* Schmidt-Göbel (SABELLA, 1998: 337); mais il n’a pris aucune décision à ce sujet. Toujours d’après SABELLA (1998: 209), *T. integer* est plus abondant (Fig. 121), et compte tenu des grands ports où arrivaient jadis les entomologistes, a une probabilité plus grande d’être le *Bryaxis opuntiae* Schmidt-Göbel. D’après la figure originale 17f, la massue antennaire est relativement grande, caractère qui milite en faveur de *T. integer*. Pour la stabilité de la nomenclature et pour résoudre ce problème d’identité, je désigne pour néotype de *Bryaxis opuntiae* Schmidt-Göbel un mâle de *Tychomorphus integer* (Reitter) de Palerme, Sicile (MHNG) (**syn. nov.**). Ce néotype porte une petite étiquette manuscrite “Palermo Si.” de 7 sur 3mm.

## REMERCIEMENTS

Mes remerciements vont à MM. Ivan Löbl pour ses remarques et suggestions judicieuses, Stanislav Vit pour la très belle figure 7, Carolus Holzschuh de Vienne et Jean-Pierre Thelot de Forcalqueiret-La Roquebrussanne pour le don de trois belles espèces nouvelles. Je tiens aussi à remercier les collègues qui m’ont communiqué pour étude des Psélaphides des collections entomologiques dont ils sont responsables: Mme Eva Sprecher du musée de Bâle (Coll. Frey), MM. Georges Coulon de l’Institut royal des Sciences naturelles de Belgique et Otto Merkl du musée de Budapest; ou de leur collection personnelle: MM. Volker Brachat de Geretsried et Guido Nonveiller de Zemun.

## BIBLIOGRAPHIE

- AUBÉ, C. 1844. Révision de la famille des Psélaphiens. *Annales de la Société Entomologique de France*, 2<sup>e</sup> série, II: 73-160, pl. 3.
- BECK, L. VON 1817. Beiträge zur baierischen Insektenfauna, oder Beschreibung und Abbildung neuentdeckter Käfer. *Augsburg*, 47 pp., 7 pl.
- BESUCHET, C. 1956. Révision des genres *Zibus*, *Saulcyella*, *Aphiliops* et description d'un genre nouveau (Col. Pselaphidae). *Mitteilungen der Schweizerischen Entomologischen Gesellschaft* 29: 363-372.
- BESUCHET, C. 1958. Coleoptera Pselaphidae et Scydmaenidae. *Revue suisse de Zoologie* 65: 891-919.
- BESUCHET, C. 1960. Coléoptères Psélaphides de la collection J. Sahlberg. *Annales Entomologici Fennici* 26: 11-31.
- BESUCHET, C. 1978. Le genre *Namunia* Reitt. (Coleoptera, Pselaphidae). *Revue suisse de Zoologie* 85: 127-133.
- BLATTNY, W. et C. 1914. Beitrag zur Kenntnis der Pselaphiden und Scydmaeniden. *Coleopterologische Rundschau* 3: 175-178.
- JEANNEL, R. 1950. Coléoptères Psélaphides. *Faune de France* 53: III + 421 pp.
- JEANNEL, R. 1952a. Exploration du Parc National de l'Upemba. Pselaphidae. *Institut des Parcs Nationaux du Congo Belge*, fasc. 13: 3-61.
- JEANNEL, R. 1952b. Sur quelques Psélaphides de France. *Bulletin et Annales de la Société Entomologique de Belgique* 88: 291-294.
- JEANNEL, R. 1956a. Les Psélaphides de l'Afrique du Nord. *Mémoires du Muséum National d'Histoire Naturelle, Paris, n.s. (Série A: Zoologie)* 14: 1-233.
- JEANNEL, R. 1956b. Sur les genres *Dimerus* Fiori et *Octomicrus* Schaufuss (Coleoptera Pselaphidae). *Revue Française d'Entomologie* 23: 84-100.
- JEANNEL, R. 1959. Révision des Psélaphides de l'Afrique intertropicale. *Annales du Musée Royal du Congo Belge, Tervuren (Série in 8°, Sciences Zoologiques)* 75: 1-742.
- KARAMAN, Z. 1948. Revizija Pselaphida (Kol.). *Zagreb: Jugoslavenska Akademija Znanosti i Umjetnosti*, 19 pp.
- KARAMAN, Z. 1963. Nouvelles espèces de *Trissenus* et de *Reichenbachia* (Col. Psel.). *Bulletin de la Société Entomologique de Mulhouse* 1963: 79-81.
- LEACH, W. E. 1817. On the stirpes and genera composing the family Pselaphidea; with the names of the British species. *Zoological Miscellany* 3: 80-87.
- LEACH, W. E. 1826. On the stirpes and genera composing the family Pselaphidae; with descriptions of some new species. *Zoological Journal* 2: 445-453.
- MACHULKA, V. 1930 (1929). Beitrag zur Synonymie der palaearktischen Pselaphiden (Coleoptera). *Clasopis Československé Společnosti Entomologické* 26: 119-121.
- NEWTON, A. F. JR. & CHANDLER, D. S. 1989. World Catalog of the Genera of Pselaphidae (Coleoptera). *Fieldiana, Zoology, New Series* 53: III + 93 pp.
- PARK, O. 1942. A Study in neotropical Pselaphidae. *Northwestern University Studies in the Biological Sciences and Medicine* 1: 1-403, 21 pl.
- RAFFRAY, A. 1903-1904. Genera et Catalogue des Psélaphides. *Annales de la Société Entomologique de France* 72: 484-604; 73: 1-476, 635-678, 3 pl.
- RAFFRAY, A. 1908. Coleoptera. Fam. Pselaphidae. *In: WYTSMAN, P. (ed.): Genera Insectorum*, fasc. 64: 487 pp., 9 pl.
- REITTER, E. 1884. Bestimmungs-Tabellen der europäischen Coleopteren. X. Nachtrag zu dem V. Theile, enthaltend: Clavigeridae, Pselaphidae und Scydmaenidae. *Verhandlungen der Kaiserlich-Königlichen Zoologisch-Botanischen Gesellschaft in Wien* 34: 59-94.
- REITTER, E. 1900. Beitrag zur Coleopteren-Fauna des russischen Reiches. *Deutsche Entomo-*

*logische Zeitschrift* 1900: 49-59.

SABELLA, G. 1998. Pselafidi di Sicilia. *Museo Regionale di Scienze Naturali Torino*; Monografie 25: 415 pp.

SAULCY, F. H. C. DE 1864. Faune française et européenne. Descriptions et remarques. *Annales de la Société Entomologique de France*, 4<sup>e</sup> série, 4: 253-260.

SCHMIDT-GÖBEL, H. M. 1836. Dissertatio inauguralis zoologica de Pselaphis faunae pragensis cum anatomia Clavigeri. *Pragae: Filiuorum Theophili Haase*, IV et 50 pp., 2 pl.





***Androdeloscia* gen. n., a new genus of South American terrestrial isopods with description of 13 new species (Crustacea: Oniscidea: "Philosciidae")**

Andreas LEISTIKOW

Universität Bielefeld, Abteilung für Zoomorphologie und Systematik,  
Morgenbreede 45, D-33615 Bielefeld / Ruhr-Universität Bochum,

Lehrstuhl für spezielle Zoologie, Universitätsstraße 150, D-44780 Bochum. Germany:  
e-mail: Leiste@Biologie.Uni-Bielefeld.de

***Androdeloscia* gen. n., a new genus of South American terrestrial isopods with description of 13 new species (Crustacea: Oniscidea: "Philosciidae").** - A new genus of philosciid Oniscidea is described for the Venezuelan species *Prosekia hamigera* (Vandel, 1952) and its Brazilian congener *P. silvatica* Lemos de Castro & Souza, 1986. They differ remarkably from *Prosekia rutilans* (Vandel, 1952) and are linked by several synapomorphies with other genera of small philosciids from South America, particularly with *Erophiloscia* Vandel, 1972 and *Andenoniscus* Verhoeff, 1941. Several new species of this genus have been found in the collections of Dr W. Hanagarth in Peru, which are now courtesy of the Staatliches Museum für Naturkunde, Stuttgart (SMNS) and in the collections undertaken by Dr C. Schmidt (Ruhr-Universität) in Venezuela in spring 1998. A diagnosis of the new genus is given, all the species included are described in detail, the inter- and infrageneric phylogenetic relationships are discussed. A key to the species is given.

**Key-words:** Isopoda - Oniscidea - South America - biogeography - phylogeny - taxonomy.

## INTRODUCTION

There are some species of Oniscidea from South America, which had been described as belonging to the genus *Chaetophiloscia* Verhoeff, 1908, a genus with linea frontalis reduced and long noduli laterales (VERHOEFF 1908). the generic diagnosis was completed by SCHMALFUSS (1990). These species were separated in the genus *Prosekia* Vandel, 1968 mainly due to some biogeographic considerations; VANDEL (1968) stated, that *Chaetophiloscia* is a genus of eastern mediterranean distribution widely absent from southern Spain and Portugal. A wide gap between the two distributional areas, circum-mediterranean and northern South America would result even when continents were transformed to their position in early Cretaceous. Addi-

tionally, he gave some characters for differentiation (VANDEL 1968, p. 118): the shape of the antennula and the length of the noduli laterales. Whereas the biogeographical argument is difficult to follow, the remarkable differences in morphology justify the separation of *Prosekia* as a genus on its own. Unfortunately, the members of *Prosekia* showed up to be a polyphyletic assembly. To reduce this genus to a monophyletic taxon, a re-examination of all its members is attempted. The first results lead to the separation of *Prosekia hamigera* (Vandel, 1952) and *P. silvatica* Lemos de Castro & Souza, 1986 into a new genus *Androdeloscia* gen. n.. They differ in many characters from *P. rutilans* (Vandel, 1952) which was the first species described of those belonging to this genus (VANDEL 1952) and should be considered as type of this genus.

The examination of a collection of Oniscidea performed in spring 1998 in Venezuela by Dr C. Schmidt (Ruhr-Universität-Bochum) revealed the presence of additional three species of *Androdeloscia* gen. n. in this region; another important collection of Oniscidea was made by Dr W. Hanagarth in Peru. The material was first examined by Dr H. Schmalfuss from the Staatliches Museum für Naturkunde, Stuttgart. He described three species of the philosciid genus *Ischioscia* Verhoeff, 1928 (SCHMALFUSS 1980) and gave a summary of the material. The other material remains undescribed until now. In this collection, members of *Androdeloscia* gen. n. were plentiful, so that 10 new species can be distinguished.

Within this work, the systematic section is followed by a paragraph on the phylogeny and biogeography of this interesting new genus.

The following acronyms are used:

SMNS Staatliches Museum für Naturkunde, Stuttgart

USNM United States National Museum, Smithsonian Institution, Washington

MNHG Muséum d'histoire naturelle, Genève

MUMV Museo de la Universidad de Maracay, Venezuela

## SYSTEMATIC SECTION

### ***Androdeloscia* gen. n.**

*Diagnosis:* Cephalothorax with linea supra-antennalis, linea frontalis in most species reduced, small lateral lobes, compound eyes consisting of about 6 ommatidia. Antennula with divergent setal tufts on distal article (fig. 64), antenna with three-articulated flagellum bearing a long apical organ.

Mandible with molar penicil composed of 3 to 6 branches, maxilla with lateral endite bearing 4+6 or 4+5 teeth, hyaline lobe rarely present, maxilla with lateral lobe twice as broad as medial lobe, maxillipedal endite with small knob-like penicil.

Pereopods slender, with small antenna-grooming brush on carpus 1, ornamental sensory spine double-fringed serrate, carpus with mediobasal setal tuft, coxal plates bearing flagelliform nodulus lateralis (fig. 64), sulcus marginalis present to rudimentary, nodulus lateralis IV more dorsally inserted than others.

Pleopods without respiratory area, exopodites rhomboid but exopodite 5, which is triangular, male exopodite 5 with straight medial margin, bearing caudally

guide slot for flagelliform endopodite 2 (fig. 64). Male exopodite 1 rounded, endopodite bearing tubercles, in some species hyaline lamellae. Genital papilla stout, with elliptic ventral shield slightly surpassed by ductus ejaculatori, apically obtuse.

Uropod with triangular protopodite laterally grooved, endopodite inserting proximally of exopodite.

Type species: *Chaetophiloscia hamigera* Vandel, 1952.

*Comments:* As VANDEL (1968) stated, the genus *Prosekia* is distinguished by the shape of the antennula and the complexity of the male pleopod endopodites. A thoroughly revision of the type material of *Andenoniscus silvaticus* Verhoeff, 1941 revealed the presence of this type of antennula also in this genus (LEISTIKOW 1998). Thus, it may be a character of a larger monophylum - provisionally called the *Prosekia*-group. The new genus is similar to *Andenoniscus* Verhoeff, 1941 and *Erophiloscia* Vandel, 1972 in the overall habitus, tiny species of maximal 5mm with slender pleon and rounded telson. In contrast to the above mentioned species, a linea frontalis is reduced in *Androdeloscia* gen. n.; another autapomorphy is the shape of the male pleopod 5 exopodite, which is apically drawn out to some extent. An even more complex character is a furrow parallel to the medial margin of the caudal surface, covered with pectinate scales. This furrow works as a guide slot for the flagelliform pleopod 2 endopodite, fitting so tight that it is sometimes impossible to remove the endopodite from the furrow without damaging it. A furrow of similar structure and function has been evolved several times within the Crinocheta, it can be found in *Chaetophiloscia* and *Philoscia* Latreille, 1804 as well (pers. obs.). The details of this structure and the lack in its closest relatives may warrant the autapomorphic status. A medially drawn out pleopod 5 exopodite in the male can be found in *Erophiloscia*, too (VANDEL 1972). In contrast to the new genus, there is no trace of a guide slot for the pleopod 2 endopodite. Most probably, *Erophiloscia* is the adelphotaxon of *Androdeloscia* gen. n. This will be dealt with in another contribution to these genera. Furthermore, several species of *Prosekia* described from the Amazon region (LEMO DE CASTRO & SOUZA 1986; LIMA 1997) have to be transferred to *Androdeloscia*. This is the result of a re-examination of the type material from the Museo Nacional, Rio de Janeiro.

*Etymology:* The genus name refers to the complex male copulatory devices of the pleopods: "andros" greek for "male", "del-" is abbreviated from greek "delos" for obvious/visible, whereas "oscia" is a suffix commonly used for Crinocheta with philosciid facies.

#### KEY TO THE SPECIES

- 1 Males with pereopod 7 bearing lobes on merus . . . . . 10
- Males with pereopod 7 without meral differentiation . . . . . 2
- 2 Fields of cuticular scales ventrally on male pereopod 4 to 6 . . . . *A. taitii* sp. n.
- No such fields on pereopods . . . . . 3
- 3 Male pleopod 1 exopodite comparatively big, more or less circular  
 . . . . . *A. opercularis* sp. n.

- Male pleopod 1 exopodite rounded but smaller than half the length of endopodite . . . . . 4
- 4 Male pleopod 1 endopodite slender, apex directed laterally, with small knobs and saddle-shaped lobe, without prominent protrusions, distal sensory spine of propus 1 with double-serrate fringe . . . . . *A. dalensi* sp.n.
- Pleopod 1 endopodite of different shape, distal sensory spine of propus 1 with one to three subapical points . . . . . 5
- 5 Male pleopod 1 endopodite with prominent protrusions . . . . . 6
- Male pleopod 1 endopodite without protrusions, apex with small knobs, looking "fir cone-like" . . . . . 8
- 6 Protrusion on endopodite directed laterally, sickle-shaped . . . . . *A. hamigera*
- Male pleopod 1 endopodite with two small protrusions . . . . . 7
- 7 Apex of endopodite finger-shaped, protrusions on halflength *A. poeppigi* sp. n.
- Apex stout, hammer-shaped due to distal protrusions . . . . . *A. malleus* sp. n.
- 8 Male pleopod 1 endopodite stout with broad base, pleopod 5 exopodite particularly drawn out . . . . . *A. conipus* sp. n.
- Male pleopod 1 endopodite with almost equally-sided triangular base . . . . . 9
- 9 Male endopodite 1 distinctly bent laterally in last third . . . . . *A. plicatipus* sp. n.
- Male endopodite 1 more or less straight . . . . . *A. feistae* sp. n.
- 10 Merus with one lobe or protrusion . . . . . 11
- Merus with more than one lobe or protrusion . . . . . 14
- 11 Protrusion on merus mediodistally . . . . . 13
- Protrusion on merus medially, more or less on halflength . . . . . 12
- 12 Pleopod 1 endopodite apically bulbous with flagelliform tip; short inner claw of pereopods . . . . . *A. ferrarai* sp. n.
- Pleopod 1 endopodite apically bulbous, obtuse, appearing spiny; inner claw almost as long as interungual seta . . . . . *A. longiunguis* sp.n.
- 13 Protrusion finger-shaped, directed distally, with sensory spine apically . . . . . *A. digitata* sp. n.
- Protrusion small lobe, pleopod 1 endopodite with flagelliform tip . . . . . *A. merolobata* sp. n.
- 14 Male pleopod 1 endopodite with distally directed protrusion of muscular part . . . . . *A. silvatica*
- Male pleopod 1 without such a protrusion . . . . . *A. pseudosilvatica* sp. n.

## SPECIES ACCOUNT

**Androdeloscia hamigera** (Vandel, 1952) comb. n.*Chaetophiloscia hamigera* Vandel, 1952*Prosekia hamigera* (Vandel): VANDEL 1968

Material: Venezuela: 2♂ (max. 3.5mm) 2♀ (ovigerous) Caripe, 10°10.51'N 63°30.21'W, garden with palms, orchids, Poaceae, ferns, under flower pots, leg. 07.04.1998 C. Schmidt, MHNG coll.: 1♂ 2♀ (ovigerous) same data, MUMV coll.: 9♂ 7♀ (ovigerous) 9♀ 6imm. same data, author's coll.: 2♂ 3♀ (ovigerous) 6♀ 2imm. Caripe, surroundings of Cueva del Guacharo, 10°35.94'N 63°11.81'W, moist forest, under rotting logs and leaf litter near

brook, leg. 07.04.1998 C. Schmidt, author's coll.; 9♂ 1♂ 11♀ 9imm, Península de Paria, Puy Puy, 10°42.00'N 62°58.05'W, bay with sandy beach, coconut palms, surrounded by dry mountains, swamp near beach, under logs and leaf litter, leg. 30.03.1998 C. Schmidt, author's coll.

Colour: Colour pattern similar to *A. dalensi* sp. n. with light spots in medial line of pereon, pleon unmarked.

Cephalothorax: Linea supra-antennalis straight, lateral lobes small, lamina frontalis present, linea frontalis lacking, compound eyes consisting of about 8 ommatidia (pl.1, Ctf).

Pereon: Tegument smooth and shiny, bearing scattered tricorn-like setae, coxal plates without gland pores, sulcus marginalis poorly individualized, noduli laterales flagelliform, on coxal plate IV more dorsally inserted (fig. 1, Cx3/Cxp).

Pleon: Set apart from pereon, neopleurae of pleonites 3 to 5 rather short, pleotelson with rounded apex, laterally straight, bearing few tricorn-like setae.

Appendages:

Antennula: Three-articulate, rather slender with distal article bearing prominent tuft of aesthetascs medially and 2 aesthetascs apically (fig. 1, An1).

Antenna: Comparatively slender, length ratio of peduncular articles 1 to 5 1: 2: 2: 4: 5, flagellum three-articulate with articles subequal in length, distal article slightly longer, apical organ half as long as flagellum (fig. 1, An2).

Mandible: Molar penicil dichotomized, composed of about seven branches, pars intermedia with two penicils on left and one on right mandible, additional plumose seta more proximally (fig. 2, Mdl/r).

Maxillula: Medial endite with two pointed penicils, apical tip medially, lateral endite with apically 3+5 teeth, four of inner set cleft, laterally fringed (fig. 2, Mx1).

Maxilla: Lateral lobe almost twice as broad as medial one, bearing pectinate scales, medial endite bearing some cusps apically (fig. 2, Mx2).

Maxilliped: Basipodite with sulcus lateralis, palp with one seta on proximal article, two setal tufts on distal articles, endite with two teeth caudally, knob-like penicil smooth (pl.2, Mxp).

Pereopods: Rather slender, especially pereopod 1, carpus with antenna-grooming brush and serrate ornamental sensory spine (fig. 3, Sc1), dactylus with short inner claw and simple dactylar seta (fig. 3, Dac).

Sexual differentiation: Pereopods 2 to 4 with fields of proximally directed cuticular setae medially on carpus and merus (fig. 3, PE4).

Pleopods: Similar to other members of the genus (fig. 3, PL1-5).

Sexual differentiation: Male pleopod exopodite circular, endopodite with falciform protrusion laterally on halflength, apex obtuse, with hyaline lamellae and hyaline lobe, caudal row of sensory spine only on distal third of pleopod. Pleopod 2 similar to next species, pleopod 5 exopodite with medial slot guide, distally protruding.

Uropod and genital papilla: As in generic diagnosis.

Comments: As in most of the species of *Androdeloscia* gen. n., the species *A. hamigera* (Vandel, 1952) is best distinguished by the shape of the male pleopod

1 endopodite. The lateral sickle-shaped protrusion is found in no other species, thus being the best character to separate the species. First described as belonging to the genus *Chaetophiloscia* Verhoeff, 1908, the species was grouped with some other South American species of *Chaetophiloscia* in a new genus *Prosekia* Vandel, 1968 mainly for biogeographic reasons (VANDEL 1968). Since it differs remarkably from *Prosekia rutilans* (Vandel, 1952) it is now part of the monophyletic group *Androdeloscia* from tropical South America. *Prosekia rutilans* has big compound eyes, a faint linea frontalis and structurally different male pleopods. E. g., pleopod 2 endopodite is short with a club-like apex, while in all members of *Androdeloscia* the endopodite is slender with a more or less flagelliform apex. A discussion of the characters of *P. rutilans* will be given elsewhere.

### ***Androdeloscia conipus* sp. n.**

Material: Peru, Dept. Huanuco; Distr. Puerto Inca, Rio Yuyapichis, Biological station "Panguana" 9°37'S 74°56'W, altitude 250m: HOLOTYPE ♂ 4mm "A2", 1.XII.1975 leg. W. Hanagarth, SMNS coll. T446; PARATYPES 4♂ 5♀, same data as holotype, SMNS coll. T447.

Colour: Dorsally brown with several white markings on the tergites, medially forming a white band which is accompanied by two paramedian rows of prominent white spots on pereonites 1 to 4, pleon with some light spots, cephalothorax dorsally densely marked white.

Cephalothorax: No linea and lamina frontalis, linea supra-antennalis and small lateral lobes present, profrons between compound eyes slightly bulbous (fig. 4, Ctf).

Pereon: Smooth and shiny tegument, coxal plates with sulcus marginalis along lateral border, no gland pores, insertion of nodulus lateralis bordered by concentric structure of the cuticle, noduli long and flagelliform, maximum of d/c-coordinates on coxal plate IV (fig. 4, Cx4/Cxp).

Pleon: Retracted from pereon, neopleurae of pleonites 3 to 5 conspicuous, pleotelson with straight margins, bearing some prominent tricorn-like setae.

Appendages:

Antennula: Three-articulate, medial tuft consisting of about 10 aesthetascs (fig. 4, An1).

Antenna: Rather stout, length ratio of peduncular articles 1 to 5 1: 2: 2: 3: 4, flagellum three-articulate, joints subequal in length, apical organ longer than distal article (fig. 4, An2).

Mandible: Pars molaris consisting of a four-branched molar penicil, pars intermedia bearing two penicils on left and one on right mandible, intermedial penicil slender (fig. 5, Mdl/r).

Maxillula: Medial endite bearing two slender penicils and apical tip, lateral article with 4+5 teeth, four of inner set cleft (fig. 5, Mx1).

Maxilla: Lateral lobe two times broader than medial one, fine hair-like setae arranged in parallel lines, medial lobe with 7 cusps apically (fig. 5, Mx2).

Maxilliped: Basipodite with sulcus lateralis, palp with proximal article bearing one seta, endite with knob-like penicil rostrally and tooth caudally (fig. 5, Mxp).

Pereopods: Slender, dactylus with short inner claw and simple dactylar seta, carpus of pereopod 1 with antenna-grooming brush reaching far laterally, ornamental sensory spine with one serrate fringe reaching more proximally than other (fig. 6, Sc1).

Sexual differentiation: No apparent sexual differentiation (fig. 6, PE1-7).

Pleopods: Exopodites of pleopod 3 and 4 prominent, bearing laterally 4 sensory spines, no respiratory areas discernible, endopodites bilobate (fig. 7, PL1-5).

Sexual differentiation: Male pleopod 1 exopodite almost circular, endopodite stout and coniform, apically pointed, with some distinct dentations laterally and caudally, caudal row of small spines reduced to area near apex (fig. 7, PL1). Pleopod 2 exopodite triangular with two lateral sensory spines, endopodite with long, flagelliform apex (fig. 7, PL2), pleopod 5 exopodite with guide slot for pleopod 2 endopodite, apically extensively drawn out (fig. 7, PL5).

Uropod: Similar to generic diagnosis.

Genital papilla: As in generic diagnosis.

Comments: This species belongs to a group which is characterized by the reduction of the hyaline lamellae on the male pleopod endopodite, which is typical for most of the members of the *Prosekia*-group. Together with the following two species, *A. feistae* sp.n. and *A. plicatipus* sp. n., is united by the apomorphic structure of the male pleopod 1 endopodite, which is pointed and bears a variety of small bosses and knobs. As in the other species of this group, the pereopods of the males are unmodified, but males can be at once separated from other species of *Androdeloscia* gen. n. by the stout pleopod 1 endopodite.

Etymology: The species name is derived from latin "*conus*" and "*pus*", meaning cone and foot, referring to the coniform endopodite of pleopod 1.

### ***Androdeloscia feistae* sp. n.**

Material: Peru, Dept. Huanuco; Distr. Puerto Inca, Rio Yuyapichis, Biological station "Panguana" 9°37'S 74°56'W, altitude 250m: HOLOTYPE ♂ 3mm, forest, IV-V.1975 leg. W. Hanagarth, SMNS coll. T478; PARATYPES 1♂ 10♀ 4 juveniles max. 4mm, same data as holotype, SMNS coll. T448; 1♂ 3mm, matorral at river side, clay soil, leg. W. Hanagarth, SMNS coll. T449; 3♂ 4 juveniles, max 3mm, matorral at river side, 4.-27.XII. 1975 leg. W. Hanagarth, SMNS coll. T450; 2♂ 12♀ max. 3.5mm, forest, II.-III.1975, leg. W. Hanagarth, SMNS coll. T451.

Colour: Most specimens were faded to yellowish brown, some light spottings on the dorsum.

Cephalothorax: Linea frontalis missing, linea supra-antennalis prominent, only slightly bent between antennal sockets, small lateral lobes, compound eyes consisting of about 7 ommatidia (fig. 8, Ctf).

Pereon: Tegument smooth and shiny, with scattered tricorn-like setae, sulcus marginalis reduced, noduli laterales flagelliform, more dorsally on coxal plate IV (fig. 8, Cx3/Cxp).

Pleon: Set apart from pereon, neopleurae of pleonites 3 to 5 adpressed, pleotelson with rounded lateral margins, bearing scattered tricorn-like setae.

Appendages:

Antennula: Distal article apically with small tip and two aesthetascs, medially with tuft of about 10 aesthetascs, medial article slightly shorter than proximal one (fig. 8, An1).

Antenna: Peduncle rather stout, article 4 only slightly longer than article 3, flagellum with distal article half as long as all three joints together, apical organ of two thirds the length of flagellum (fig. 8, An2).

Mandible: Pars intermedia with two penicils left and one right, molar penicil consisting of about 4 branches, additional penicil distally (fig. 9, Mdl/r).

Maxillula: Medial endite with two penicils and small tip apically, lateral endite with 4+6 teeth apically, inner set consisting of 5 cleft and one vestigial tooth, small spine subapically, cuticular lobe sublaterally, both on rostral surface (fig. 9, Mx1).

Maxilla: Lateral lobe more than twice as broad than medial lobe, bearing scattered pectinate setae, medial lobe with 9 cusps apically (fig. 9, Mx2).

Maxilliped: Basipodite with short sulcus lateralis, endite bearing two teeth caudally, small knob-like penicil rostrally, palp with single seta on proximal article, medial and distal article with setal tufts (fig. 9, Mxp).

Pereopods: Slender with short setal tufts on carpus laterodistally, antenna-grooming brush of carpus 1 very small, tricorn-like setae slender, ornamental sensory spine serrate (fig. 10, Sc1), dactylus with short inner claw, dactylar seta simple (fig. 10, Dac).

Sexual differentiation: Apparently no prominent sexual differentiation, male ischium 6 and 7 with only one sensory spine laterally (fig. 10, PE1-7).

Pleopods: Exopodites of pleopods 2 to 4 rhomboid, of pleopod 5 almost triangular, laterally with about 1 to 3 sensory spines, no respiratory areas discernible in light microscope, endopodites bilobate (Fig. 10, PLx; fig. 11, PL1-5).

Sexual differentiation: Male pleopod 1 exopodite rounded, endopodite straight, muscular basal part short, apex acute, slightly twisted, i. e. caudal row of spines running on rostral side, some cuticular hooks directed proximally, hyaline serrate lobe fairly motile (fig. 11, PL1). Pleopod 2 as in other species of this genus (pl.11, PL2), exopodite of pleopod 5 with sulcus medially for pleopod 2 endopodite, distally only pointed (fig. 11, PL5).

Uropod: As in other species of genus (fig. 10, UR).

Genital papilla: Similar to generic diagnosis.

Comments: *Androdeloscia feistae* sp. n. together with *A. plicatipes* sp. n. are the sister species of the preceding species, they share as an apomorphy the shape of the male pleopod 1 endopodite which is rather slender with a basal part of triangular shape containing the muscle M49 (cf. ERHARD 1997). Different to its sister species, the endopodite is straight and not laterally bent. Further apomorphies are the reduction of sensory spines on ischium 6 to one in contrast to two.

Etymology: This species is named for Mrs R. Feist, University of Bielefeld in honour for her help in SEM preparations and photography.



**Androdeloscia plicatipus** sp. n.

Material: Peru, Dept. Huanuco; Distr. Puerto Inca, Rio Yuyapichis, Biological station "Panguana" 9°37'S 74°56'W, altitude 250m: HOLOTYPE ♂ 3mm, field with maniok 12.-27.XII.1975 leg. W. Hanagarth, SMNS coll. T479; PARATYPES 2♂ 9♀ 2 juveniles max. 3.5mm, same data as holotype, SMNS coll. 452; 5♂ 1♀, max. 2.5mm, matorral at river side, 4.-27.XII.1975, leg. W. Hanagarth, SMNS coll. T453; 3♂ 18♀ 2 juveniles, max. 3.5mm, area with kudzu tropical. III.-V.1975, leg. W. Hanagarth, SMNS coll. T454; 6♂ 55♀ 2 juveniles, max.3.5mm, forest. XII.75-I.1976, leg. W. Hanagarth, SMNS coll. T455; 1♂ 2♀ same data. USNM coll.

Colour: Reddish brown, slightly faded, dorsum with light patches at least on coxal plates, cephalothorax heavily spotted yellowish.

Cephalothorax: Linea frontalis absent, area slightly bulbous, linea supra-antennalis prominent, almost straight between antennal sockets, small lateral lobes present, compound eyes consisting of about 6 ommatidia (fig. 12, Ctf).

Pereon: Tegument shiny, dorsum bearing scattered tricorn-like setae, coxal plates with reduced sulcus marginalis and flagelliform noduli laterales, insertion area with small concentric grooves, more dorsally on coxal plate IV (fig. 12, Cx4/Cxp).

Pleon: Retracted from pleon, neopleurae of pleonites 3 to 5 conspicuous, telson with straight margins, bearing few slender tricorn-like setae.

**Appendages:**

Antennula: Three-articulate, medial article shortest, distal article apically with small tip and two aesthetascs, medially with about 10 aesthetascs (fig. 12, An1).

Antenna: Peduncle rather stout, article 5 only slightly longer than flagellum and peduncular article 4, three-articulate flagellum with long apical organ, half as long as flagellum (fig. 12, An2).

Mandible: Molar penicil consisting of 4 branches, left pars intermedia with two penicils and several coniform setae, right bearing few setae and one penicil (fig. 13, Mdl/r).

Maxillula: Medial endite with two penicils apically, lateral endite with stepped setal fringe laterally, apically with 4+6 teeth, five of inner set cleft, innermost simple tooth vestigial (fig. 13, Mx1).

Maxilla: Lateral lobe two times broader than medial, bearing several trichiform setae and pectinate scales, apically about 8 clusps (fig. 13, Mx2).

Maxilliped: Basipodite with short sulcus lateralis, endite with two teeth caudally and knob-like penicil rostrally, palp with two unequal setae on proximal article, medial and distal article each bearing setal tuft, lateral setae rather stout (fig. 13, Mxp).

Pereopods: Pereopods rather slender, with setal tuft laterodistally on carpus, carpus I with antenna-grooming brush, ornamental sensory spine serrate (fig. 14, Sc1), dactylus with short inner claw and simple dactylar seta, interungual seta curved (fig. 14, Dac). Medial sensory spines of merus 6 closer together than in preceding species (fig. 14, Sm6).

Sexual differentiation: Only slight differentiation, male pereopod 7 ischium medially lacking sensory spines (fig. 14, PE1-7).

Pleopods: Similar to the preceding species, medial protrusion of pleopod 3 protopodite rather long (fig. 15, PL1-5).

Sexual differentiation: Male pleopod 1 exopodite rounded, endopodite with short basal part containing muscle M49, distal part slender, one third before apex strongly grooved and bent laterally, twisted, short row of spines, apex with several decurved cuticular hooks (fig. 15, PL1). Pleopod 2 exopodite pyriform, without sensory spines, endopodite slender, not as flagelliform as in preceding species (fig. 15, PL2), pleopod 5 exopodite with guide slot for endopodite 2, apically only slightly drawn out (fig. 15, PL5).

Uropod: Similar to other species.

Genital papilla: As in other members of genus.

Comments: This species is close to the preceding, *A. feistae* sp. n. from which it is immediately distinguished by the shape of male pleopod 1 endopodite as described above. Therefore, its structure is more complex in comparison to the other two species of the "cone pleopod"-group which also includes *A. conipus* sp. n. A synapomophy of *A. plicatipus* sp. n. and *A. feistae* sp. n. is that there is only one medial sensory spine on the male ischium 7 instead of two as in other species.

Etymology: The species name is derived from latin "*plicatus*" meaning "folded" and "*pus*" for "foot" due to the shape of pleopod 1 endopodite.

### ***Androdeloscia taitii* sp. n.**

Material: Peru, Dept. Huanuco; Distr. Puerto Inca, Rio Yuyapichis, Biological station "Panguana" 9°7'S 74°6'W, altitude 250m: HOLOTYPE ♂ 4mm, matorral at river side, sandy soil, 20.VII.1975 leg. W. Hanagarth, SMNS coll. T456; PARATYPES 3♂ 3♀ 1 juvenile, max. 4mm, same data as holotype, SMNS coll. T457; 1♂ 4.5mm, secondary forest of 10 years in flood area, 23.IV.1975. leg. W. Hanagarth, SMNS coll. T458.

Colour: Dorsum faded to reddish brown, few light spots visible, cephalothorax heavily spotted, pleon uniformly coloured.

Cephalothorax: Linea supra-antennalis strongly decurved between antennal sockets, small lateral lobes, linea frontalis lacking, compound eyes consisting of about 7 ommatidia (fig. 16, Ctf).

Pereon: Pereonites with few tricorn-like setae, tegument smooth, coxal plates with proximally reduced sulcus marginalis, noduli laterales long, flagelliform, insertion on coxal plate IV considerably dorsal (fig. 16, Cx3/Cxp).

Pleon: Retracted from pereon, rather short, with small neopleurae on pleonites 3 to 5, pleotelson with straight lateral margins.

Appendages:

Antennula: Three-articulate, proximal article rather slender, distal article with two aesthetascs apically, broken in dissected antennule, medial set of about 10 aesthetascs (fig. 16, An1).

Antenna: More slender than in preceding species, especially flagellum, medial article shortest, apical organ as long as distal article (fig. 16, An2).

Mandible: Pars intermedia only sparsely setose, molar penicil composed of 4 rather short branches, right lacina mobilis deeply sinuous apically (fig. 17, Mdl/r).

Maxillula: Medial endite with small tip and two penicils apically, medial endite with hyaline cuticular lobe and 4+6 teeth, four of innermost set cleft (fig. 17, Mx1).

Maxilla: Lateral lobe two times broader than medial one, bearing trichiform setae, medial lobe bearing stronger setae, apically with about six cusps (fig. 17, Mx2).

Maxilliped: Basipodite with sulcus lateralis almost reduced, palp with two setae on proximal article, setal tufts on distal articles, innermost consisting of 3 setae, endite bearing knob-like penicil rostrally and two teeth caudally (fig. 17, Mxp).

Pereopods: Rather slender, especially pereopod 1, carpus with antenna-grooming brush and apically serrate ornamental sensory spine, carpus of pereopods 3 and 4 with hyaline cuticular fringe mediolaterally (fig. 18, PE3/4), laterodistal tufts small, dactylus with simple dactylar seta and short inner claw (fig. 18, Dac).

Sexual differentiation: Male merus of pereopod 2 and 3 with quadrangular, of pereopod 4 to 6 with acute, proximally directed cuticular scales medially (fig. 18 PE1-4; fig. 19, PE 6-7).

Pleopods: Exopodites of pleopod 3 and 4 rhomboid, laterally with 3 to 4 sensory spines, exopodite 5 more triangular, lacking respiratory areas, endopodites bilobate (fig. 20, PL1-5).

Sexual differentiation: Male pleopod 1 exopodite pointed, shape characteristic: almost straight from lateral insertion on protopodite to apex, medially much more rounded at the base, endopodite with short basal area containing muscle M49, distally straight up to the bulbous apex, bearing two horns, medially with groove, and twisted, row of spines beginning caudally, ending more apically on rostral side, lateral area of bulb rostrally with hyaline lamellae, caudally granulate (fig. 20; PL1). Pleopod 2 exopodite similar to exopodite 1, even more drawn out medioproximally, no sensory spines, endopodite slender, less tapered than *A. feistae* sp. n. (fig. 20, PL2), exopodite 5 triangular with lateral furrow, pointed (fig. 20, PL5).

Uropod and genital papilla: As in generic diagnosis.

Comments: This and the following four species form a monophyletic group within *Androdeloscia* gen. n. characterized by the shape of the pleopod 1 exopodite in the male which appears to be inverted, i.e. the lateral margin turned medially. A synapomorphy of *A. taitii* sp. n., *A. merolobata* sp. n. and *A. longimuguis* sp. n. is the distorted pleopod 1 endopodite in the male: the spermatic channel is turning from the caudal to the rostral side, thus, the caudal row of spines is ending on the rostral side. Beside the shape of the male pleopod 1 endopodite, *A. taitii* sp. n. is at once distinguished by the lack of lobes on the merus 7, it only shows areas of cuticular scales on most of the pereopods.

Etymology: The species is dedicated to Dr S. Taiti, Florence, one of the leading specialists of Oniscidea.

### ***Androdeloscia merolobata* sp. n.**

Material: Peru, Dept. Huanuco; Distr. Puerto Inca, Rio Yuyapichis, Biological station "Panguana" 9°37'S 74°56'W, altitude 250m: HOLOTYPE ♂ 5mm, forest, X.-XI.1975 leg. W. Hanagarth, SMNS coll. T459; PARATYPES 2♂ 10♀ 1 juvenile, max. 5.5mm, same data as holotype, SMNS coll. T460; 5♂ several ♀ and juveniles, max. 5mm, cattle meadow with kudzu, 1975-1976 leg. W. Hanagarth, SMNS coll. T461; 3♂ 14♀ 1 juvenile, max.5.5mm, forest, VI.-VII.1975 leg. W. Hanagarth, SMNS coll. T462; 9♂ 9♀ 1 juv., max. 5.5mm, forest,

XI.1975-I.1976 leg. W. Hanagarth, SMNS coll. T463; 1♂ 2♀ same data, USNM coll.; 3♂ 2♀ max. 5.5mm, area with kudzu tropical, 12.VI.1975 leg. W. Hanagarth, SMNS coll. T464; 3♂ 2♀ max. 5.5mm, area with kudzu tropical, 27.IV.1975 leg. W. Hanagarth, SMNS coll. T465; 3♂ max. 4.5mm, forest, II.1975 leg. W. Hanagarth, SMNS coll. T466.

Colour: Dorsally reddish brown with yellowish spottings, medial line dark brown, on pereonites 5 to 7 bifurcated, pleonites uniformly reddish brown, cephalothorax with light spotting.

Cephalothorax: Linea supra-antennalis straight, lateral lobes small, linea frontalis lacking, compound eyes consisting of about 7 ommatidia (pl.21, Ctf).

Pereon: Tegument smooth and shiny, bearing scattered tricorn-like setae, coxal plates without gland pores, sulcus marginalis poorly individualized, noduli laterales flagelliform, on coxal plate IV more dorsally inserted (pl.21, Cx3/Cxp).

Pleon: Set apart from pereon, neopleurae of pleonites 3 to 5 rather short, pleotelson with rounded apex, laterally straight, bearing few tricorn-like setae.

Appendages:

Antennula: As in preceding species (pl.21, An1).

Antenna: Fairly slender, peduncular article 2 stout, flagellum three-articulate, joints subequal in length, apical organ half as long as flagellum (pl.21, An2).

Mandible: Pars intermedia with two penicils on left, one on right side, some coniform setae, molar penicil consisting of four branches, additional penicil slender (fig. 22, Mdl/r).

Maxillula: Medial endite with two penicils and lateral tip apically, lateral endite with fringe of stepped setae, more distally stouter and individualized, apical teeth 4+6, four of innermost cleft, simple teeth short, subapical vestigial tooth on rostral surface (fig. 22, Mx1).

Maxilla: Lateral lobe twice as broad as medial one, covered with rows of trichiform setae, medial lobe apically cuspidate, bearing trichiae (fig. 22, Mx2).

Maxilliped: Basipodite with conspicuous sulcus lateralis, endite apically setose, with two teeth on caudal. small knob-like penicil on rostral surface, proximal article of palp bearing two setae, distal lobes with setal tufts (fig. 22, Mxp).

Pereopods: Pereopods slender, small setal tuft laterodistally on carpus, carpus 1 with small antenna-grooming brush and apically serrate ornamental sensory spine (fig. 23, Sc1), dactylus with short inner claw and simple dactylar organ (fig. 23, Dac).

Sexual differentiation: Male pereopod 2 to 3 merus with quadrangular cuticular scales, merus 4 to 6 with acute cuticular scales, pereopod 7 merus with semicircular lobe mediodistally on caudal side, bearing cuticular scales, covering a third of length of merus (fig. 23, PE1-4; pl.24, PE5-7).

Pleopods: Pleopod exopodites 3 to 4 rhomboid with 3 to 4 sensory spines laterally, without respiratory area, endopodites bilobate, pleopod 5 more pointed (pl.25, PL1-5).

Sexual differentiation: Male pleopod 1 exopodite similar to *A. taii* sp. n., endopodite at its base slightly smaller than protopodite, basis containing M49 triangular, distal part twisted, row of spines turned to rostral side, apex bulbous with transverse groove on caudal side, sides of spermatic furrow serrate, rostral side with

some cuticular granules and hyaline lamellae, bulb terminated by laterally directed flagellar extension (fig. 25, PL1). Pleopod 2 exopodite with broad rounded apex, bearing 3 sensory spines laterally, endopodite slender, distal half flagelliform (fig. 25, PL2), pleopod 5 exopodite triangular with slightly drawn out apex, caudally with medial guide slot for endopodite 2 (fig. 25, PL5).

Uropod and genital papilla: As in other members of genus (fig. 24, UR).

Comments: As the species name infers, *A. merolobata* sp. n. bears a medio-distal lobe on merus 7 in the male. This and the complex shape of the male pleopod 1 endopodite are autapomorphies of this species which forms the adelphotaxon of *A. longiunguis* sp. n., the apomorphy is the shape of pleopod 2 exopodite with two sensory spines laterally. It is united with *A. taitii* and its sister species by the distortion of the male pleopod 1 endopodite. *A. merolobata* sp. n. was the by far commonest of all its congeners in the Panagua area, it was collected at many sites in big numbers. It occurred in both forest and open areas as cleared places for agriculture.

Etymology: The species name refers to the lobe on the male pereopod 7 merus.

### ***Androdeloscia longiunguis* sp. n.**

Material: Peru, Dept. Huanuco; Distr. Puerto Inca, Rio Yuyapichis, Biological station "Panguana" 9°37'S 74°56'W, altitude 250m: HOLOTYPE ♂ 4mm, area with kudzu tropical 5.IX.1975 leg. W. Hanagarth, SMNS coll. T467.

Colour: The only male of this species rather faded, so that spotting invisible, dark median line dorsally.

Cephalothorax: Linea frontalis lacking, linea supra-antennalis present, small lateral lobes and slight lamina frontalis, compound eyes consisting of about 8 ommatidia (fig. 26, Ctf).

Pereon: Pereonites covered with small tricorn-like setae, tegument smooth, coxal plates without sulcus marginalis and gland pores, noduli laterales long, flagelliform, nodulus of coxal plate IV the most dorsal one (fig. 26, Cx3/Cxp).

Pleon: Set apart from pereon, neopleurae of pleonites 3 to 5 small but clearly visible, pleotelson with rounded lateral margin, bearing several tricorn-like setae.

Appendages:

Antennula: Similar to other species of the genus, apical tuft with 3 aesthetascs (fig. 26, An1).

Antenna: Rather stout, length ratio of peduncular articles 1 to 5 is 1: 2: 2: 3: 4, flagellum three-articulate, distal article longest, apical organ slightly longer (fig. 26, An2).

Mandible: Molar penicil consisting of 3 branches, pars intermedia with 2 penicils and coniform setae on left, one penicil and few setae right, additional seta long (fig. 27, Mdl/r).

Maxillula: Medial endite with small tip and 2 penicils apically, lateral endite with lateral fringe similar to *A. merolobata* sp. n., tooth formula 4+6, with four teeth of inner set cleft, innermost simple tooth short, hyaline cuticular lobe present, rostrally with subapical vestigial tooth (fig. 27, Mx1).

Maxilla: Lateral lobe more than two times broader than medial, heavily covered with trichiform setae, medial lobe bearing about 6 cusps (fig. 27, Mx2).

Maxilliped: Basipodite with sulcus lateralis, palp with two setae on proximal article, two setal tufts on distal articles, endite with two teeth caudally, knob-like penicil rostrally (fig. 27, Mxp).

Pereopods: Rather slender, especially pereopod 1, carpus with antenna-grooming brush and serrate ornamental sensory spine (fig. 28, Sc1), dactylus with long inner claw and simple dactylar seta (fig. 28, Dac).

Sexual differentiation: Male pereopod 2 to 4 with cuticular scales on merus, or cuticular plaques in pereopod 5 and 6, merus 7 with sinuous lobe bearing sensory spine proximally of halflength (fig. 28, PE1-7).

Pleopods: As in the preceding species (fig. 29, PL1-5).

Sexual differentiation: Male pleopod 1 exopodite similar to *A. merolobata*, endopodite structurally similar, twisted with row of small spines rostrally, two caudal grooves vertically, apex less bulbous, rather square, long cuticular spines directed medially, hyaline lamellae on rostral surface (fig. 29, PL1). Pleopod 2 and 5 similar to preceding species (fig. 29, PL2/5).

Uropod and genital papilla: As in generic diagnosis (fig. 26, UR).

Comments: The name-giving long inner claw, the location of the meral lobe and the shape of the male pleopod 1 endopodite are the autapomorphies of this species. *A. longiunguis* sp. n. is linked with the preceding species by the shape and setation of the male pleopod 2 exopodite.

Etymology: The species name is derived from latin for stressing the long inner claw of the dactylus.

### ***Androdeloscia ferrarai* sp.n.**

Material: Peru, Dept. Huanuco; Distr. Puerto Inca, Rio Yuyapichis, Biological station "Panguana" 9°37'S 74°56'W, altitude 250m: HOLOTYPE ♂ 5mm. "VT 57a RC22-21", 15.V.1976 leg. W. Hanagarth, SMNS coll. T496; PARATYPES 3♂ 6♀ 5 juveniles, max. 5.5mm, same data as holotype, SMNS coll. T470; 6♂ 38♀ 6 juveniles, max. 3mm, field with annual manjok, 12.-27.XII.1975 leg. W. Hanagarth, SMNS coll. T471; 1♂ 2♀ same data, USNM coll.

Colour: Reddish to purplish brown, pereon with pale dorsal spotting, light patches on coxal plates, pleon uniformly coloured.

Cephalothorax: No linea frontalis, linea supra-antennalis present, small lateral lobes and slight lamina frontalis, compound eyes consisting of about 10 ommatidia (fig. 30, Ctf).

Pereon: Smooth and shiny tegument, coxal plates with sulcus marginalis, no gland pores, noduli laterales long and flagelliform, most dorsally on coxal plate IV (fig. 30, Cx3/Cxp).

Pleon: Retracted from pereon, neopleurae of pleonites 3 to 5 conspicuous, pleotelson with straight margins, bearing several prominent tricorn-like setae.

Appendages:

Antennula: Three-articulate, rather slender with distal article bearing prominent tuft of aesthetascs medially and 2 aesthetascs apically (fig. 30, An1).

Antenna: Comparatively slender, length ratio of peduncular articles 1 to 5 1: 2: 2: 4: 5, flagellum three-articulate with articles subequal in length, distal article slightly longer, apical organ even longer (fig. 30, An2).

Mandible: Molar penicil consisting of 4 branches, left pars intermedia with two penicils and several coniform setae, right bearing few setae and one penicil (pl.31, Mdl/r).

Maxillula: Medial endite with small tip and two penicils apically, medial endite with hyaline cuticular lobe slender, 4+5 teeth, four of innermost set cleft (fig. 31, Mx1).

Maxilla: Lateral lobe slightly broader than medial, almost without setation, medial lobe setose with about 10 apical cusps (fig. 31, Mx2).

Maxilliped: Basipodite with conspicuous sulcus lateralis, endite apically setose, with two teeth on caudal surface, small knob-like penicil lacking, proximal article of palp bearing two setae, distal lobes with setal tufts, proximal one consisting of two setae (fig. 31, Mxp).

Pereopods: Pereopods rather slender, with setal tuft laterodistally on carpus, carpus 1 with antenna-grooming brush, ornamental sensory spine serrate (fig. 32, Sc1), dactylus with short inner claw and simple dactylar seta, interungual seta curved (fig. 32, Dac), merus 3 to 4 with hyaline cuticular fringe (fig. 32, PE3/4).

Sexual differentiation: Male pereopod merus 5 with hyaline cuticular fringe, merus 6 with cuticular scales medially, pereopod 7 merus with small setose hump distally at half-length (pl.33, PE5-7).

Pleopods: Similar to preceding species, endopodites with straight to concave distal margin (fig. 34, PL1-5).

Sexual differentiation: Male pleopod 1 exopodite as in preceding species, endopodite with rather broad basal part containing M49, of half-length of endopodite, apical part bulbous, terminally drawn out, laterally with bulbous lobes, each separated by groove, distally some cuticular hooks, medially some granules, caudally with subapical row of spines, apically some hyaline lamellae (fig. 34, PL1). Pleopod 2 endopodite with two lateral sensory spines, endopodite with flagelliform distal part (fig. 34, PL2), pleopod 5 exopodite with medial guide slot caudally, slightly pointed (fig. 34, PL5).

Uropod: Protopodite only slightly grooved between insertion of endo- and exopodite.

Genital papilla: Margins of ventral shield almost parallel, slightly surpassed by ductus ejaculatorii (fig. 34, Gen).

Comments: The male pleopod 1 endopodite may be referred to as somehow near to the ground plan of the "inverted exopodite"-group. The presence of a lamina frontalis is somewhat surprising and must be interpreted as a silent gene expression. The maxilliped endite lacks the penicil on the rostral surface, this reductive character is an autapomorphy of this species. As in the preceding species, the shape of both male merus 7 and pleopod 1 endopodite at once distinguish *A. ferrarai* sp. n. from its congeners.

**Etymology:** This species is dedicated to Dr F. Ferrara, Florence, one of the leading scientists of Oniscidea systematics.

***Androdeloscia poeppigi* sp. n.**

**Material:** Peru, Dept. Huanuco; Distr. Puerto Inca, Rio Yuyupichis, Biological station "Panguana" 9°37'S 74°56'W, altitude 250m: HOLOTYPE ♂ 2.5mm, "A3.4", 16.XI.1975, leg. W. Hanagarth, SMNS coll. 472; PARATYPES 2♂ 4♀ 1 juvenile, max.3.5mm, same data as holotype, SMNS coll. T473.

**Colour:** Yellowish brown, rather faded due to alcohol preservation, thus spotting badly discriminable.

**Cephalothorax:** Linea frontalis absent, area slightly bulbous, linea supra-antennalis prominent, almost straight between antennal sockets, small lateral lobes present, compound exes consisting of about 7 ommatidia (fig. 35, Ctf).

**Pereon:** Tegument smooth and shiny, coxal plates with sulcus marginalis rostrally, long flagelliform nodulus lateralis, nodulus lateralis of coxal plate IV inserting more medially than others (fig. 35, Cx2/Cxp).

**Pleon:** Set apart from pereon, neopleurae of pleonites 3 to 5 adpressed, pleotelson with straight lateral margins, bearing few scattered tricorn-like setae.

**Appendages:**

**Antennula:** Three-articulate, proximal article rather slender, distal article with two aesthetascs apically, broken in dissected antennule, medial set of about 10 aesthetascs (fig. 35, An1).

**Antenna:** Peduncle rather stout, article 4 only slightly longer than article 3, flagellum with distal article half as long as all three joints together, apical organ of two thirds the length of flagellum (fig. 35, An2).

**Mandible:** Molar penicil consisting of 4 branches, left pars intermedia with two slender penicils and several coniform setae, right bearing few setae and one penicil, additional penicil present (fig. 36, Mdl/r).

**Maxillula:** Medial endite with two penicils and lateral tip apically, lateral endite with fringe of stepped setae, more distally stouter and individualized, apical teeth 4+5, four of inner set cleft, second lateral tooth rather short, decurved (fig. 36, Mx1).

**Maxilla:** Lateral lobe more than two times broader than medial, heavily covered with pectinate scales, medial lobe bearing about 7 cusps (fig. 36, Mx2).

**Maxilliped:** Basipodite with sulcus lateralis, endite caudally with two teeth, rostrally bearing knob-like penicil, palp with one seta on proximal article, medial article with proximal tuft of 2 short setae, distal tuft of 2 setae (fig. 36, Mxp).

**Pereopods:** Slender with short setal tufts on carpus laterodistally, antennagrooming brush of carpus 1 dense, lateroproximally with 2 tricorn-like setae, ornamental sensory spine serrate (fig. 37, Sc1), dactylus with short inner claw, dactylar seta simple (fig. 37, Dac).

**Sexual differentiation:** Apparently no sexual dimorphism (fig. 37 PE1-7).

**Pleopods:** Exopodites of pleopods 3 to 4 rhomboid, of pleopod 5 almost triangular, laterally with about 2 to 4 sensory spines, no respiratory areas discernible in light microscope, endopodites bilobate (fig. 38, PL1-5).



Sexual differentiation: Male pleopod 1 exopodite rounded with inconspicuous point, basal part of endopodite containing M49 slightly individualized, distal part pointed, no caudal row of spines, apex obtuse, two protrusions on lateral and medio-rostral side at about half length, the latter better discernible when endopodite separated from protopodite (fig. 38, PL1). Pleopod 2 exopodite triangular, bearing one lateral sensory spine subapically, endopodite more than twice as long as exopodite, not as flagelliform as in preceding species (fig. 38, PL2). Pleopod 5 exopodite with medial guide slot and drawn out apex (fig. 38, PL5).

Uropod: Similar to other species of the genus (fig. 35, UR).

Genital papilla: Rather stout, ventral shield slightly ovoid (fig. 38, Gen).

Comments: Together with *A. malleus* sp. n., *A. poeppigi* sp. n. forms the adelphotaxon of the "fir-cone"-species group, the small finger-shaped humps on the male endopodite of pleopod 1 and the reduction of the caudal row of spines are their synapomorphies. Different to *A. malleus* sp. n., this species has a narrow male pleopod 1 endopodite with the humps arranged more proximally in contrast to the former.

Etymology: This species is named after E. F. Poeppig, one of the first explorers of the Amazon basin.

#### ***Androdeloscia malleus* sp. n.**

Material: Peru, Dept. Huanuco; Distr. Puerto Inca, Rio Yuyapichis, Biological station "Panguana" 9°37'S 74°56'W, altitude 250m: HOLOTYPE ♂ 3mm, "A2" 1.XII.1975, leg. W. Hanagarth, SMNS coll. T474; PARATYPES 3♂ 3♀ max. 3.5mm, same data as holotype, SMNS coll. 475, 3♂ 28♀, max. 3.5mm, forest, VIII.-IX.1975, leg. W. Hanagarth SMNS coll. T476, 5♂ 23♀ 2 juveniles, max. 3.5mm, forest, VI.-VII.1975 leg. W. Hanagarth, SMNS coll. T477.

Colour: As in other species of the genus, dorsally reddish brown with light markings of muscle insertions, cephalothorax heavily spotted.

Cephalothorax: Linea frontalis missing, area slightly bulbous, linea supra-antennalis prominent, only slightly bent between antennal sockets, small lateral lobes, compound eyes consisting of about 7 ommatidia (fig. 39, Ctf).

Pereon: Tegument shiny, dorsum bearing scattered tricorn-like setae, coxal plates with reduced sulcus marginalis and flagelliform noduli laterales, insertion area with small concentric grooves, maximum of d/c-coordinates on coxal plate IV (fig. 39, Cx3/Cxp).

Pleon: Retracted from pereon, neopleurae visible, pleotelson with rounded distal margin, laterally straight, bearing few, short tricorn-like setae.

Appendages:

Antennula: Distal article apically with small tip and two aesthetascs, medially with tuft of about 9 aesthetascs, medial article slightly shorter than proximal one (fig. 39, An1).

Antenna: More slender than in preceding species, especially flagellum, distal article longest, proximal articles subequal in length, apical organ longer than distal article (fig. 39, An2).

Mandible: Pars molaris consisting of a four-branched molar penicil, pars intermedia bearing two penicils on left and one on right mandible, intermedial penicil slender (fig. 40, Mdl/r).

Maxillula: Similar to preceding species (fig. 40, Mx1).

Maxilla: Lateral lobe only slightly broader than medial lobe, bearing pectinate scales, medial lobe sparsely covered with trichiae, apically cuspidate (fig. 40, Mx2).

Maxilliped: As in *A. poeppigi* sp. n., but distal setal tuft of media article of palp comprising about 4 setae (fig. 40, Mxp).

Pereopods: Rather slender, especially pereopod 1, carpus with antenna-grooming brush and serrate ornamental sensory spine (fig. 41, Sc1), propus 1 with 2 distal sensory spines serrate on one side, dactylus with long inner claw and simple dactylar seta (fig. 41, Dac).

Sexual differentiation: Pereopods in both sexes similar (fig. 41, PE1-7).

Pleopods: Pleopod exopodites 3 and 4 elongate rhomboid with 3 to 4 sensory spines laterally, exopodite 5 more or less triangular, endopodites bilobate, no respiratory areas discernible in light microscope (fig. 42, PL1-5).

Sexual differentiation: Male pleopod 1 exopodite rounded, endopodite rather stout, apex hammer-shaped, some minute spines caudally present, spermatic furrow laterally open, on lateral side of apex few granules (fig. 42/43, PL1). Pleopod 2 and 5 similar to preceding species (fig. 42, PL2/5).

Uropod: As in other species of genus.

Genital papilla: Ventral shield stout, ovoid, slightly surpassed by ductus ejaculatorii (fig. 42, Gen).

Comments: This is the sister species of *A. poeppigi* sp.n., differing mainly in the shape of male pleopod 1 endopodite. *A. malleus* has the two lobe more apically thus forming the "hammer"-like apical region. The endopodite is rather stout and as in the preceding species, it lacks the hyaline lamellae which are so characteristic for this genus although they do not represent an autapomorphy of *Androdeloscia* gen. n..

Etymology: The latin term "malleus" means "hammer" and refers to the shape of the male pleopod 1 endopodite.

### ***Androdeloscia opercularis* sp. n.**

Material: Venezuela: HOLOTYPE ♂ 3mm, Falcón, Parque Morrocoy, Península de Morrocoy, northern shore, Cueva del Indio (carstic cave with crushed ceiling, within detritus in small niches and edges of the rock, under stones on bottom leg. 18.03.1998 C. Schmidt MHNG coll.; PARATYPES 1♂ 3♀, same data as holotype, MHNG coll.; 9♂ 5♀, about 80 imm., same data as holotype, author's coll.

Colour: Purplish brown with pereon and pleon dorsally bearing light spots, medial line of pereon dark brown.

Cephalothorax: Linea frontalis absent, area slightly bulbous, linea supra-antennalis prominent, almost straight between antennal sockets, small lateral lobes present, compound eyes consisting of about 7 ommatidia (fig. 44, Ctf)

Pereon: Smooth and shiny tegument, coxal plates with sulcus marginalis along lateral border, no gland pores, insertion of nodulus lateralis bordered by concentric

structure of the cuticle, noduli long and flagelliform, on coxal plate IV more dorsally (fig. 44, Cx1/Cxp)

Pleon: Retracted from pereon, neopleurae of pleonites 3 to 5 adpressed, pleotelson with straight margins, bearing some prominent tricorn-like setae.

Appendages:

Antennula: Distal article apically with small tip and two aesthetascs, medially with tuft of about 10 aesthetascs, medial article much shorter than proximal one (fig. 44, An1).

Antenna: Peduncle rather slender, article 4 two times longer than article 3, flagellum with distal article as long as other joints, apical organ of two thirds the length of flagellum (fig. 44, An2).

Mandible: Pars molaris consisting of a five-branched molar penicil, pars intermedia bearing two penicils on left and one on right mandible, intermedial penicil slender (fig. 45, Mdl/r).

Maxillula: Medial endite with two penicils and apical tip, lateral endite bearing 4+5 teeth, inner set cleft, one short subapical tooth caudally, lateral fringe of trichi-form setae stepped (fig. 45, Mx1).

Maxilla: Lateral lobe slightly broader than medial one, fine hair-like setae arranged in parallel lines, medial lobe with 7 cusps apically (fig. 45, Mx2).

Maxilliped: Basipodite with sulcus lateralis, palp with proximal article bearing two setae, endite with knob-like penicil rostrally and tooth caudally (fig. 45, Mxp).

Pereopods: Slender with many tricorn-like setae, pereopod 1 to 6 with hyaline fringes on medial border, pereopod 1 with antenna-grooming brush on carpus, ornamental seta double-fringed serrate (fig. 46, Sc1), dactylus with short inner claw and simple dactylar seta, interungual seta apically swollen (fig. 46, Dac).

Sexual differentiation: Medial margin of pereopod 2 to 4 merus with fields of proximally directed cuticular setae (fig. 46, PE1-7).

Pleopods: Exopodite of pleopods 3 rhomboid, pleopod 5 almost triangular, pleopod 4 intermediate, laterally with 2 sensory spines, no respiratory areas discernible in light microscope, endopodites bilobate (fig. 47, PL1-5).

Sexual differentiation: Male pleopod 1 exopodite circular with transverse folding medially of insertion in protopodite, comparatively large, endopodite proximally stout, muscle insertion area of M49 slightly protruding distally, apical part with lobe rostrally, apex protruding, rostrally with two rows of knobs, laterally serrate, caudally with hyaline lamellae, caudal row of spines from half-length of interlocking area with genital papilla not reaching apex (fig. 47, PL1). Pleopod 2 exopodite with broad rounded apex, bearing 3 sensory spines laterally, endopodite slender, distal half flagelliform (fig. 47, PL2), pleopod 5 exopodite triangular with slightly drawn out apex, caudally with medial guide slot for endopodite 2 (fig. 47, PL5).

Uropod: As in other species of the genus.

Genital papilla: Ventral shield rather slender with parallel margins, ductus ejaculatorii slightly surpassing ventral shield (fig. 47, Gen).

Comments: This is one of the species with rather simple apical part of the

pleopod 1 endopodite, from its congeners *A. opercularis* sp. n. is at once separable by the huge rounded exopodites of pleopod 1, which almost covers the pleoventral area.

Etymology: The species name "*opercularis*" refers to the big pleopod 1 exopodites of the male.

***Androdeloscia silvatica*** (Lemos de Castro & Souza, 1986) comb. n.

*Prosekia silvatica* Lemos de Castro & Souza, 1986

Material: Venezuela: 2♂ (max. 3mm) 3♀ (ovigerous), Península de Paria, eastern part of south coast, 10°35.94'N 63°11.81'E, along brook with cocoa plantations and moist forest, upper part with water, concrete pond with moist bottom under leaf litter, leg. 09.04.1998 C. Schmidt, MNHG coll.; 3♂ 11♀ same data, author's coll.; 2♂, 3♀ (ovigerous) Península de Paria, Puy Puy 10°42.00'N 62°58.05'W, bay with sandy beach, coconut palms, surrounded by dry mountains, banana plantation at the eastern part of the bay, in leaf litter, leg. 31.03.1998 C. Schmidt, MUMV coll.; 17♂ 12♀ (ovigerous) 6imm same data, author's coll.

Colour: Dorsally purplish brown with pale spots on pereon, medial line dark brown, white central stripe on pereonites I to IV, double line on pereonites V to VII, pleon unmarked.

Cephalothorax: Linea frontalis lacking, linea supra-antennalis and lamina frontalis present, small lateral lobes, compound eyes consisting of seven ommatidia (fig. 48, Ctf).

Pereon: Tegument smooth and shiny, coxal plates lacking gland pores, sulcus marginalis reduced, noduli laterales present, long and flagelliform, with maximum of d/c-coordinates on coxal plate IV (fig. 48, Cx3/Cxp).

Pleon: Retracted from pereon, neopleurae of pleonites 3 to 5 adpressed, pleotelson with straight distal margin, bearing some tricorn-like setae.

Appendages:

Antennula: Three-articulate with prominent proximal article, distal joint bulbous, bearing two distinct sets of aesthetascs (fig. 48, An1).

Antenna: Antennal peduncle composed of five articles with length ratio 1: 2: 2: 3: 4, densely covered with tricorn-like setae, flagellum composed of three articles, distal one bearing prominent apical organ, as long as flagellar articles 1 and 2 together (fig. 48, An2).

Mandible: Pars intermedia only sparsely setose, molar penicil composed of 3 rather short branches, right lacina mobilis deeply sinuous apically (fig. 49, Mdl/r).

Maxillula: Medial endite with small tip and two penicils apically, medial endite with subapical tooth and 4+5 teeth, four of innermost set cleft (fig. 49, Mx1).

Maxilla: Lateral lobe two times broader than medial one, bearing trichiform setae and pectinate scales, medial lobe bearing stronger setae medially, apically with about six cusps (fig. 49, Mx2).

Maxilliped: Basipodite with conspicuous sulcus lateralis, endite with two teeth on caudal surface, small knob-like penicil rostrally, proximal article of palp bearing two setae, distal lobes with setal tufts, proximal one consisting of two setae (fig. 49, Mxp).

Pereopods: Pereopods rather slender, with setal tuft laterodistally on carpus,

carpus 1 with antennal-grooming brush, ornamental sensory spine serrate (fig. 50, Sc1), dactylus with medium-sized inner claw and simple dactylar seta, interungual seta straight (fig. 50, Dac), merus 2 to 4 with hyaline cuticular scales (fig. 50, PE2).

Sexual differentiation: Male pereopod 7 with two small lobes mediodistally, caudally of distal sensory spine, proximally directed lobe on medioproximal edge, covered with small scales (fig. 50, PE1-7).

Pleopods: Similar to preceding species, endopodites more triangular (fig. 51, PL1-5).

Sexual differentiation: Male pleopod 1 exopodite with slight point, endopodite with broad basis, followed by broad part without musculature with distally directed lateral protrusion, apical part decurved laterally, apex bearing three rows of knobs, caudally a trace of hyaline lamellae, row of spines short (fig. 51, PL1). Pleopod 2 exopodite triangular with one sensory spine laterally, endopodite with flagelliform distal half (fig. 51, PL2). Pleopod 5 exopodite with guide slot for pleopod 2 exopodite (fig. 51, PL5).

Uropod and genital appendage : See generic diagnosis (fig. 51, Gen).

Comments: *A. silvatica* shares the character, that the pereopod 7 merus bears three lobes medially with the following species. This character was not depicted by Lemos de Castro & Souza in the original description (1986), possibly the examined specimen was a young male or the pereopod 7 was substitutional and, therefore, does not show all the characters of a mature male. Its autapomorphies are the shape and position of lobes on merus 7 and the shape of pleopod 1 endopodite, which looks like a tin-opener of a Swiss Officer's knife.

### ***Androdeloscia pseudosilvatica* sp. n.**

Material: Venezuela: HOLOTYPE 1♂ 3mm, Quebrada de la Virgen, 8°58.20'N 69°47.57'W, dry plain, agriculture, near a well under flower pots beneath a tree in puddle, leg. 25.03.1998 C. Schmidt; PARATYPES 1♂ 1♀ (marsupium), same data as holotype, MHNG coll.; 4♂ 1♀ (marsupium) 1imm. same data as holotype, author's coll.

Colour: Dorsally reddish to purplish brown, pereon spotted with light markings, pereonites V to VII with light medial spot, pleon uniformly coloured.

Cephalothorax: Vertex strongly arched, linea frontalis reduced, linea supra-antennalis and slight lateral lobes present, no lamina frontalis, compound eyes composed of about seven ommatidia (fig. 52, Ctf).

Pereon: Tegument rather smooth with scattered tricorn-like setae, coxal plates with sulcus marginalis and nodulus lateralis (fig. 52, Cx3/Cxp), no gland pores visible at 400x magnification.

Pleon: Set apart from pereon, small neopleurae on pleonites 3 to 5, laterally adpressed, pleotelson with straight lateral margins, bearing few tricorn-like setae.

Appendages:

Antennula: As in other species of the genus. (fig. 52, An1)

Antenna: Peduncle rather stout, length ratio from proximal to distal 1: 2: 2: 3: 4, flagellum three-articulate, joints subequal in length, medial and distal article with pair of aesthetascs, apical organ long and slender, half of length of flagellum, short

free sensilla (fig. 52, An2).

Mandible: Molar penicil consisting of about 4 branches, pars intermedia bearing two on left and one penicil on right mandible, additional plumose seta proximally (fig. 53, Mdl/r).

Maxillula: Medial endite with two penicils and inconspicuous subapical tip, lateral endite apically bearing 4+5 teeth, four of inner set cleft, laterally with trichiae, medial area with trichiae fused and forming hyaline plaques (fig. 53, Mx1).

Maxilla: Lateral lobe broader than medial one, slightly setose, medial lobe bearing about 5 cusps (fig. 53, Mx2).

Maxilliped: Basipodite with sulcus lateralis, endite with small knob-like penicil on rostral side, palp with three setal tufts medially (fig. 53, Mxp).

Pereopods: Pereopod 1 with antenna-grooming brush, ornamental sensory spine double-fringed serrate (fig. 54, Sc1), hyaline cuticular scales on merus 1 and 2, dactylus with short inner claw and simple dactylar seta (fig. 54, Dac).

Sexual differentiation: Male pereopod 7 merus with two crenulate lobes mediodistally, another lobe more proximally at insertion of basal sensory spine (fig. 54, PE1-7).

Pleopods: Pleopod endopodites slightly bilobate, exopodites 3 and 4 rhomboid, with 3 lateral sensory spines, no respiratory areas (fig. 55, PL1-5).

Sexual differentiation: Male pleopod 1 exopodite rounded with small distal point, endopodite basis strong, a small furrow separating muscle insertion M49 from muscle-free part, apical third much more slender, slightly directed laterally, bearing small knobs rostrally, caudal row of spines short, lateral margin of spermatic channel not reaching proximally to interlocking area with genital papilla, trace of hyaline lamellae apically (fig. 55, PL1). Pleopod 2 and 5 similar to preceding species (fig. 55, PL2/5).

Uropod and genital papilla: As in other species (fig. 55, Gen).

Comments: Similar to *A. silvatica*, *A. pseudosilvatica* sp. n. bears three lobes on merus 7 in the male, the position is a little bit different. The pleopod 1 endopodite is not as drawn out as in the preceding species, only a small furrow is present laterally. Different to *A. silvatica*, this species has a complete sulcus marginalis on the coxal plates and lacks the lamina frontalis.

### ***Androdeloscia dalensi* sp. n.**

Material: Venezuela: HOLOTYPE ♂ 4mm, Andes, road from Timotes to Mérida, 8°53.72' N 70°47.99'W 3400 +- 500m, very steep northern slope, covered with Bryophyta, Pteridophyta, Poaceae, Ericaceae, between Bryophyta, leg. 23.03.1998 C. Schmidt, MNHG coll.; PARATYPES 1♂ 2♀ (ovigerous), same data as holotype, MHNG coll.; 2♂ 3♀ (ovigerous) 1 imm., same data as holotype, author's coll.

Colour: Pereon and pleon dorsally purplish brown, both with prominent pale patches.

Cephalothorax: Linea frontalis lacking, linea supra-antennalis and lamina frontalis present, small lateral lobes, compound eyes consisting of eight ommatidia (fig. 56, Ctf).

Pereon: Tegument smooth and shiny, coxal plates lacking gland pores and

sulcus marginalis, noduli laterales present, long and flagelliform, more dosally inserted on coxal plate IV (fig. Cx3/Cxp).

Pleon: Retracted from pereon, neopleurae visible, adpressed; pleotelson with straight distal margin, bearing some slender tricorn-like setae.

Appendages:

Antennula: Three-articulate, medial article shortest, distal article apically with small tip and two aesthetascs, medially with about 10 aesthetascs (fig. 56, An1).

Antenna: Peduncle rather stout, article 5 only slightly longer than flagellum and peduncular article 4, three-articulate flagellum with long apical organ, half as long as flagellum (fig. 56, An2).

Mandible: Molar penicil consisting of 5 branches, left pars intermedia with two penicils and several coniform setae, right bearing few setae and one penicil (fig. 57, Mdl/r).

Maxillula: Medial endite with two penicils apically, lateral endite with stepped setal fringe laterally, apically with 4+5 slender teeth, five of inner set cleft, subapical tooth caudally (fig. 57, Mx1).

Maxilla: Lateral lobe two times broader than medial, bearing several trichiform setae and pectinate scales, apically about 6 cusps (fig. 57, Mx2).

Maxilliped: Basipodite with short sulcus lateralis, endite with two teeth caudally and prominent knob-like penicil rostrally, palp with two unequal setae on proximal article, medial and distal article each bearing setal tuft, lateral setae rather stout (fig. 57, Mxp).

Pereopods: Slender with short setal tufts on carpus laterodistally, antenna-grooming brush of carpus 1 dense, lateroproximally with 3 tricorn-like setae, ornamental sensory spine serrate (fig. 58, Sc1), sensory spine of propus 1 pointed, subapically serrate (fig. 58, Sp1), dactylus with short inner claw, dactylar seta simple (fig. 58, Dac).

Sexual differentiation: Male pereopod 7 carpus with proximal sensory spine very strong, acute and decurved, standing on protrusion (fig. 58, PE1-7).

Pleopods: Pleopod exopodites 3 rhomboid, pleopod 4 subquadrangular, pleopod 5 triangular, with 1 to 3 sensory spines laterally, without respiratory area, endopodites bilobate (fig. 59, PL1-5).

Sexual differentiation: Male pleopod 1 exopodite rounded, endopodite slender, transverse groove one third before apex, distal part decurved laterally, bearing a saddle-shaped lobe and several small knobs, caudal row of spines only on last third subapically (fig. 59, PL1). Pleopod 2 with triangular exopodite, bearing two sensory spines laterally, endopodite with distal half flagelliform (fig. 59, PL2), pleopod 5 exopodite with guide slot for apex of pleopod 2 endopodite (fig. 59, PL5).

Uropod: As in the other species.

Genital appendage: Ventral shield slightly surpassed by ductus ejaculatorii, rather slender (fig. 59, Gen).

Comments: *A. dalensi* sp. n. is a somewhat isolated species within the genus. The male has a strong sensory spine on the carpus of pereopod 7, the pleopod is bent laterally, some knobs are present apically, but no lamellae. The sulcus marginalis of

the coxal plates is completely reduced. Within this genus these characters can be found only in this species. The outline of the body is more slender than in other congeners.

**Etymology:** This species is dedicated to Dr H. Dalens (Toulouse) in honour of his life's work on Oniscidea.

***Androdeloscia digitata* sp. n.**

**Material:** Brazil: HOLOTYPE ♂ 3.5mm. Amazon rain forest near Manaus, EMBRAGA field project, MNHG coll.; PARATYPES 1♀ (ovigerous) MNHG coll.; 5♂ 1♀ limm same data as holotype, author's coll.

**Colour:** Purplish brown with many light spots dorsally on pereon, medial line marked by white spots on pereonite III to VII and pleonites.

**Cephalothorax:** Linea frontails lacking, linea supra-antennalis present, small lateral lobes and slight lamina frontalis, compound eyes consisting of about 8 ommatidia (fig. 60, Ctf).

**Pereon:** Pereonites covered with small tricorn-like setae, tegument smooth, coxal plates without sulcus marginalis and gland pores, noduli laterales long, flagelliform. nodulus of coxal plate IV the most dorsal one (fig. 60, Cx3/Cxp).

**Pleon:** Retracted from pereon, neopleurae of pleonites 3 to 5 conspicuous, pleotelson with straight margins, bearing some prominent tricorn-like setae.

**Appendages:**

**Antennula:** Three-articulate, medial tuft consisting of about 10 aesthetascs (fig. 61, An1).

**Antenna:** Fairly slender, peduncular article 2 stout, flagellum three-articulate, joints subequal in length, apical organ half as long as flagellum (fig. 60, An2).

**Mandible:** Pars molaris consisting of a four-branched molar penicil, pars intermedia bearing two penicils on left and one on right mandible, intermedial penicil slender (fig. 61, Mdr).

**Maxillula:** Medial endite bearing two penicils apically, lateral tip, lateral endite with 4+4 teeth, inner set cleft, subapical tooth caudally (fig. 61, Mx1).

**Maxilla:** Lateral lobe slightly broader than medial one, bearing scattered pectinate scales, medial endite apically with 5 cusps (fig. 61, Mx2).

**Maxilliped:** Basipodite with sulcus lateralis, palp with one small seta on proximal article, endite with knob-like penicil rostrally and two strong teeth caudally (fig. 61, Mxp).

**Pereopods:** As in the preceding species, dactylar seta rather short (fig. 62, Sc1/Dac).

**Sexual differentiation:** Male pereopod 7 with rostral protrusion on mediobasal margin, half as long as carpus with distally inserted sensory spine (fig. 62, PE1-7).

**Pleopods:** Pleopod exopodites subtriangular, laterally bearing 2 to 4 sensory spines, endopodites slightly bilobate, no respiratory areas (fig. 63, PL1-5).

**Sexual differentiation:** Male pleopod 1 with pointed exopodite, medially widely rounded, endopodite with small distal protrusion of basal part, distal third



slender, apex slightly bulbous, crenulate, with hyaline lamellae caudally and rostrally directed lobe (fig. 63, PL1). Pleopod 2 exopodite triangular with two lateral sensory spines, exopodite with flagelliform distal half (fig. 63, PL2), pleopod 5 with medial guide slot and distinctly pointed apex (fig. 63, PL5).

Uropod and genital appendage: As in other species of the genus (fig. 63, Gen).

Comments: Another member of *Androdeloscia* gen.n. bearing a lobe on the male merus 7, but different to the preceding species, in *A. digitata* sp.n. the lobe is very long, directed distally and bears a sensory spine at its tip. Together with its characteristically shaped male pleopod 1 endopodite, the species cannot be confused with other species. The lack of a sulcus marginalis is most probably explained as convergence to other species of *Androdeloscia* gen. n.

Etymology: The species name is derived from the latin "*digitus*" which means "finger" and refers to the protrusion on the male pereopod 7 merus.

#### PHYLOGENY AND BIOGEOGRAPHY

Within the genus, some distinct groups can be traced. The phylogeny of the whole genus shall be elucidated in the following, the relationships are figured in fig. 65. For the outgroup comparison the species *Prosekia rutilans* (Vandel, 1952), *Andeniscus silvaticus* Verhoeff, 1941 and *Ischioscia martinae* Leistikow, 1997 were used.

As stated above, *Androdeloscia* gen. n. belongs to a group of South American "philosciids" which are characterized by the peculiar shape of the antennula. The autapomorphies of the genus are the reduction of the linea frontalis and the shape of the pleopod 5 exopodite in the male with its guide slot structure (character set 1). The former character is not strongly supporting the monophyly since it is a reductive character. Thus, it can easily occur in evolution by a single substitutional event in the genome. The latter character is rather complex and may thus warrant monophyly. The evolution of several characters are of importance within this genus: sexual differentiations of the pereopods and the structure of the male pleopod 1. The primitive character state of the male pleopod 1 endopodite is characterized by a set of hyaline lamellae on the medial margin of the apex. The most basal species of this genus is *A. dalensi* which shows the autapomorphies of the genus but has a serrate distal sensory spine of the propus 1 and a mandibular penicil composed of more than 5 branches, both plesiomorphic characters even found in *P. rutilans*; autapomorphies are the reduction of both lamina frontalis and hyaline lamellae on the male pleopod 1 endopodite.

*A. hamigera* is the next derived species in the shape of the sensory spine (character 2) but has still a prominent molar penicil. All the other species are united by the molar penicil consisting of a long and three short branches, a reductive character but may be used for the phylogenetic reconstruction because of the correspondence of the number of branches and their length (character 3). Half of the species, the members of group A, are equipped with meral lobes and humps in the male, the pleopod 1 exopodite is enlarged, bearing a small point apically (character

set 4). The former character can also be found in the genus *Audenouiscus* Verhoeff, 1941. Since the latter genus is excluded from the monophyletic taxon *Audrodelsocia* by the plesiomorphic character state of the male pleopod 5 as far as it is known and the slightly different shape of the cephalothorax, an autapomorphy of *Audenouiscus*, there is evidence for either an analogy or the expression of a silent gene in both genera (cf. STURM 1994). Additionally the lobes are different in their position in *Audenouiscus* and *Audrodelsocia*. Within group A, four species can be separated in group B by having the male pleopod 1 endopodite with slight lateral humps (character 5). All the species save *A. digitata* have this slight hump more prominent and somewhat enlarged distally (character 6). The species *A. silvatica* (Lemos de Castro & Souza, 1986) and *A. pseudosilvatica* have the synapomorphy of three lobes on the merus, one subproximally and two distally on the medial margin (character 7). The following four species, group C, the adelphotaxon of the preceding ones, are characterized by these apomorphies (character set 8): Distal sensory spine of propus 1 with one tip, pleopod 1 endopodite apically bulbous, pleopod 1 exopodite with distal point laterally (not medially as in pleopod 2, the exopodite looking "inverted"). In *A. ferrarai* the lobes of the merus are slight, the pleopod 1 endopodite is straight, the plesiomorphic character state, while *A. taitii*, *A. uerolobata*, *A. loughiunguis* the endopodite is twisted, the spermatic channel ending on the rostral side, males have fields of cuticular scales on the merus of pleopod 2 to 6 (character set 9). In this group, *A. uerolobata* and *A. loughiunguis* most probably are sister species, with having strong meral lobes and a pleopod 2 exopodite which is distally obtusely rounded (character set 10). The latter character is less evolved in *A. taitii* and the meral lobe is missing, this is most parsimoniously explained by reduction of this structure.

Another phyletic lineage heads to a species group of Caribbean and Amazonian distribution, the group D: The last five species are united by the lack of hyaline lamellae on the male pleopod 1 endopodite, all the species share a rather slender maxilliped with the distolateral edge of the basipodite almost rectangular and not rounded as in the other species (character set 11). In the next evolutionary step the knobs and bumps are concentrated apically on both sides of the endopodite, the apex looking like a fir cone (group E, character 12). Within this group, *A. feistae* and *A. plicatipus* are sister species. They are united by the shape of the basal part of pleopod 1 endopodite, it is broad but then narrowed laterally. Thus, the part containing M49 is short compared to the other species (character 13). The adelphotaxon of group E are *A. poeppigi* and *A. wallens* with the male pleopod 1 endopodite bearing two strong lobes which are twisted out of the sagittal plane, the spermatic channel is medially open (character set 14).

From the biogeographic point of view, the different groups are found in the Amazonian and Caribbean subregion of the Neotropical realm. The basal species, *A. dalensi*, *A. hamigera* and *A. opercularis* are distributed in Venezuela, which is part of the Caribbean subregion. The group of species with meral lobes can be found in most of Amazonia and even in Venezuela, they may have been split off in the two groups with the species of the group C are exclusively found in the foothills of the Andes, part of the Amazonian subregion, as are the members of the group D, while their

sister group (group B) is distributed in Venezuela and the central Amazonian sub-region. Interestingly, *A. silvatica* can be found in both subregions; in Venezuela it was found in the east, on Península de Paria, while its sister species was found in the western part of Venezuela in the foothills of the Cordillera de Mérida. They may vicariate each other. The species from Amazonia are more basal and may be close to *A. dalensi* save *A. tarumae* (Lemos de Castro, 1984) which has two lobes on the male merus 7, and is a link between *A. digitata* and *A. silvatica*. The other species are described in LEMOS DE CASTRO & SOUZA (1986) and LIMA (1997).

Until now, the collecting of Oniscidea in South America was very scarce. Therefore, our knowledge on the distribution of genera is rather patchy. As one can deduce from the above mentioned, the genus *Androdeloscia* gen. n. is widely distributed in the Amazonian and Caribbean subregion of the Neotropis. From the point of our knowledge, it has a radiation centre in the eastern slopes of the Andes, where many species can be found occurring sympatrically. They may be found in different habitat, but there is more research needed to elucidate this question. The relatively high diversity in the Andean foothills was explained by the successive settlement by forms from the Amazon valley via dispersal along rivers and colonization by forms from the higher Andean regions. Possibly, a mix of species from both altitudinal regions can be found in this area. Such a faunal composition was postulated by SIMPSON & HAFFER (1978), since these areas have strongly been affected by both climatic changes and oreographic transformantions from the Tertiary on. The species in this area have the most diverse pleopodal structures in the males. This diversity must be explained by evolving in isolated habitats for a considerable period. Once the species barriers were established, there was a selective pressure to evolve unequivocal copulatory devices, a process of character displacement, selecting the extremes within the intra-specific variation. Hence, the some most complex male pleopods can be found in the eastern slopes of the Andes with their high number of sympatric species while in Venezuela the male pleopod 1 endopodites are structurally simple.

#### ACKNOWLEDGEMENTS

For the loan of the material, the author thanks Dr H. Schmafuss, Staatliches Museum für Naturkunde, Stuttgart and Dr P. S. Young, Museo Nacional, Rio de Janeiro. He is indebted to Prof. Dr J. W. Wägele and Dr C. Schmidt, Ruhr-Universität Bielefeld both for giving the opportunity to examine the collections made by them in Venezuela and for fruitious discussion on the manuscript.

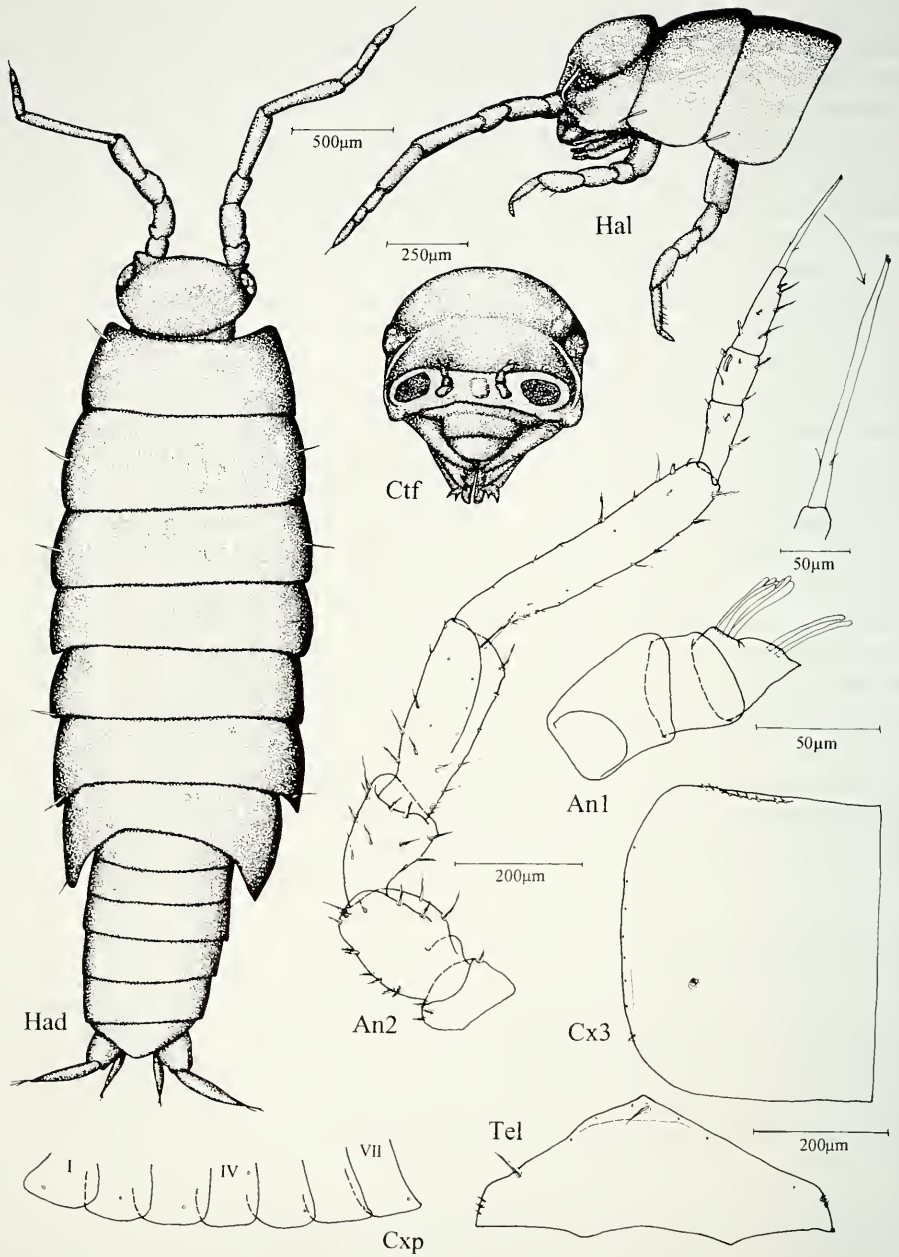

FIG. 1

*Androdeloscia hamigera* (Vandel, 1952). An1 antenna; An2 antenna with detail of apical organ; Ctf cephalothorax in frontal view; Cxp coxal plates with position of noduli laterales; Cx3 coxal plate 3; Had habitus in dorsal view; Hal habitus in lateral view; Tel pleotelson.



FIG. 2

*Androdeloscia hamigera* (Vandel, 1952). Mdl/r left and right mandible; Mxp maxilliped with detail of endite in rostral view; Mx1 maxillula with detail of apex of lateral endite; Mx2 maxilla.

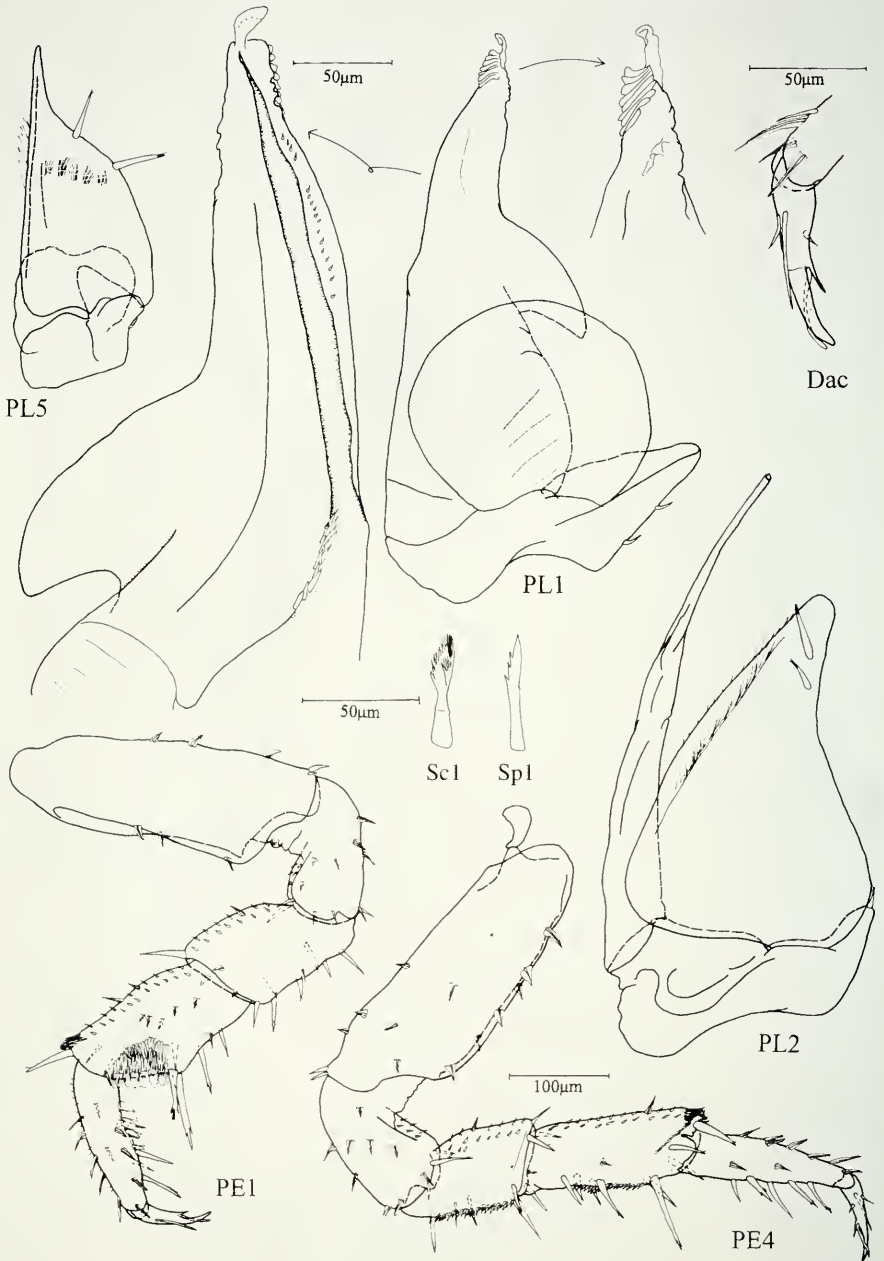

FIG. 3

*Androdeloscia hamigera* (Vandel, 1952). Dac dactylus 1 in rostral view; PE1/4 pereopods 1 (rostral view) and 4 (caudal view); PL1-5 pleopods 1 to 5, with details of pleopod 1 endopodite; Sc1 ornamental sensory spine of carpus 1; Sp1 distal sensory spine of propus 1.

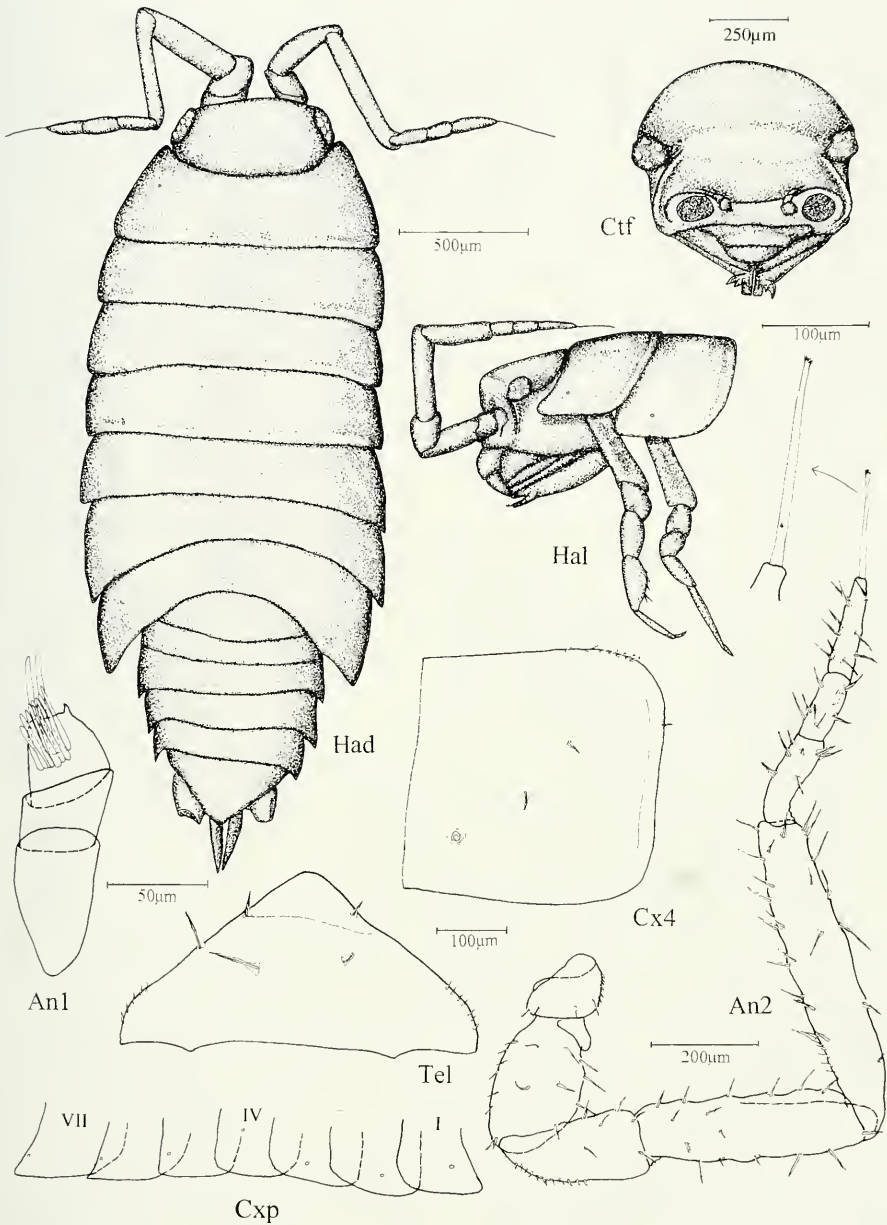

FIG. 4

*Androdeloscia conipus* sp. n. holotype ♂ 4mm. An1 antennula; An2 antenna with detail of apical organ; Ctf cephalothorax in frontal view; Cxp coxal plates with position of noduli laterales; Cx4 coxal plate 4; Had habitus in dorsal view; Hal habitus in lateral view; Tel pleotelson.

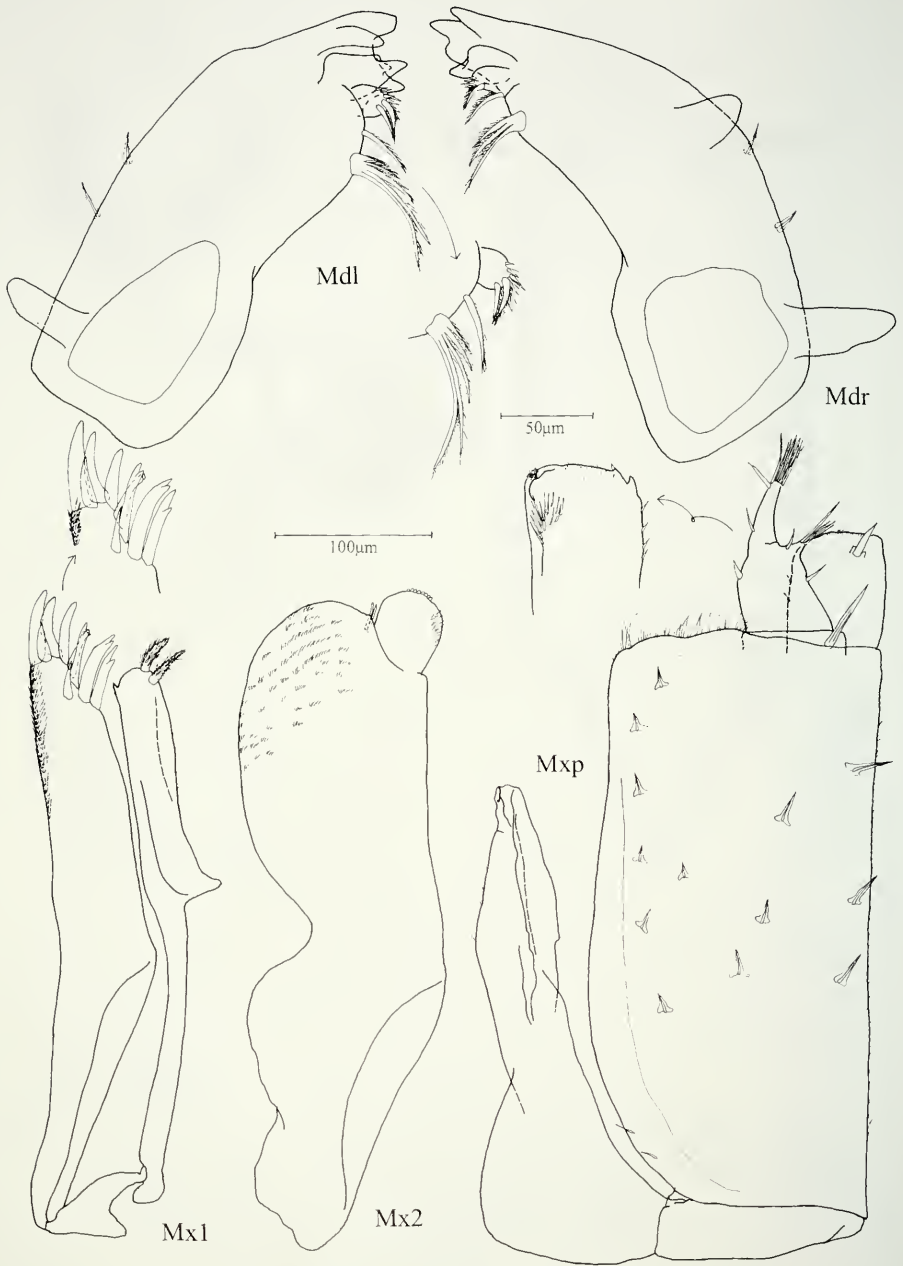

FIG. 5

*Androdeloscia conipus* sp. n. holotype ♂ 4mm. Mdl/r left and right mandible; Mxp maxilliped with detail of endite in rostral view; Mx1 maxillula with detail of apex of lateral endite; Mx2 maxilla.



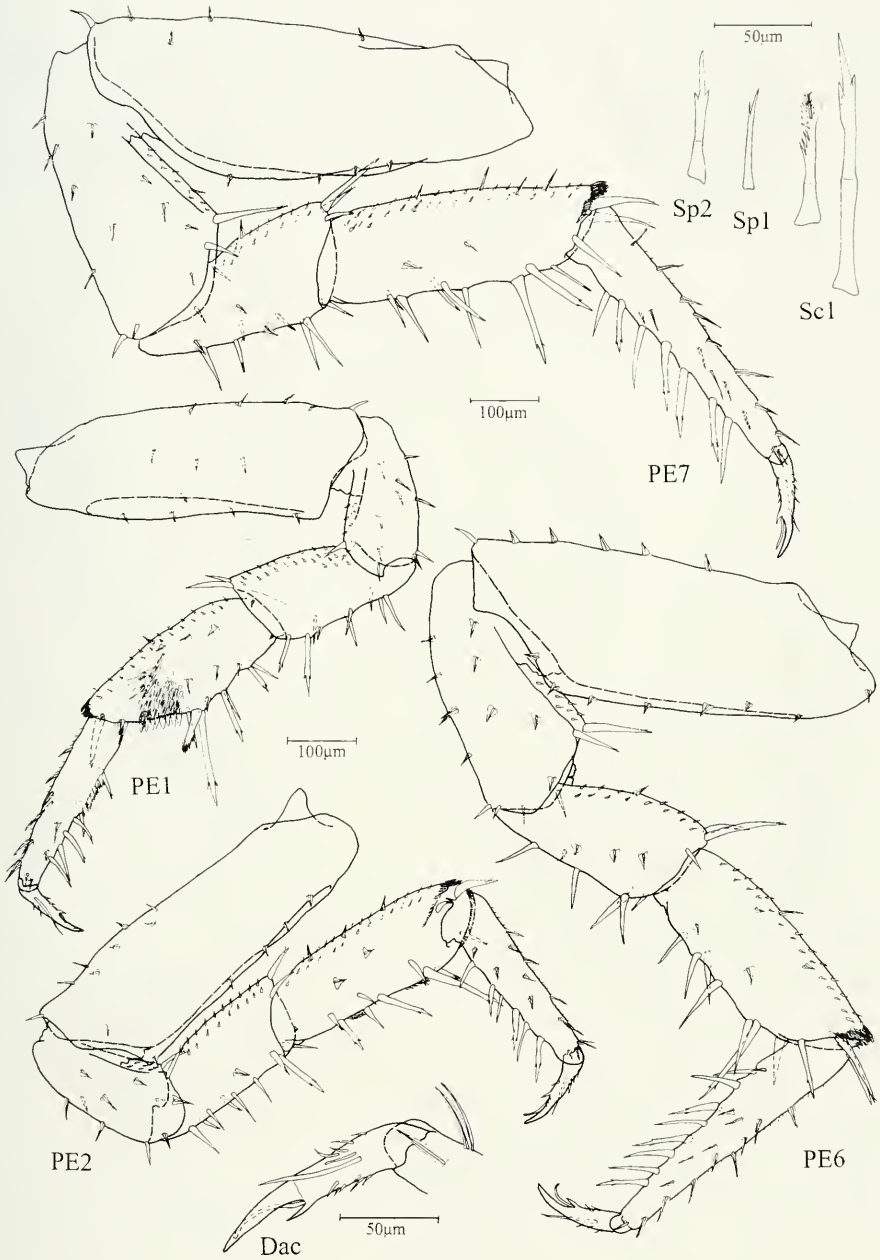

FIG. 6

*Androdeloscia conipus* sp. n. holotype ♂ 4mm. Dac dactylus 1 in rostral view; PE1-7 pereopods 1 (rostral view), 2, 6, 7 (caudal view); Sc1 ornamental sensory spine of carpus 1; Sp1 distal sensory spine of propus 1; Sp2 sensory spine of propus 2.

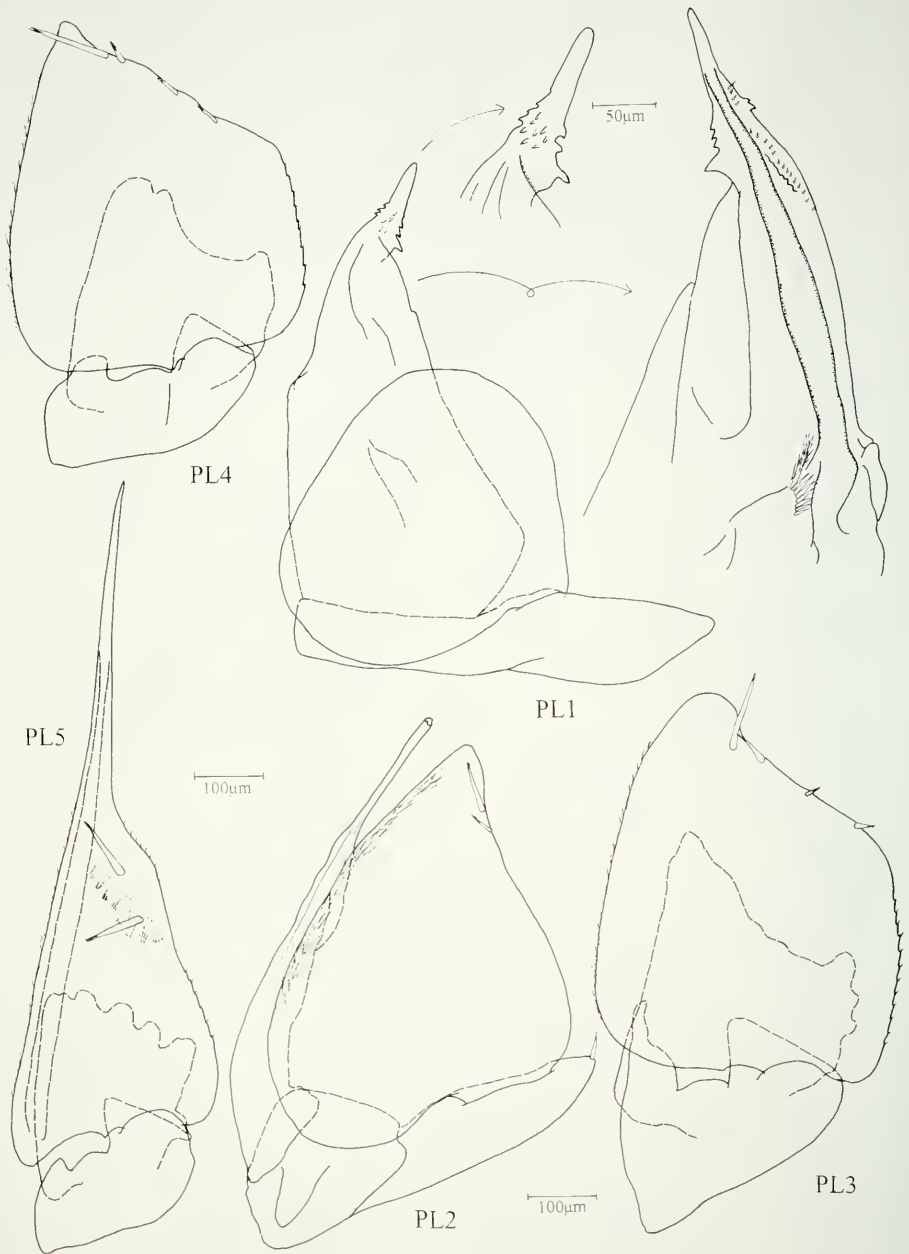

FIG. 7

*Androdeloscia conipus* sp. n. holotype ♂ 4mm. PL1-5 pleopods 1-5, rostral view, with details of endopodite 1 in caudal and rostral view.

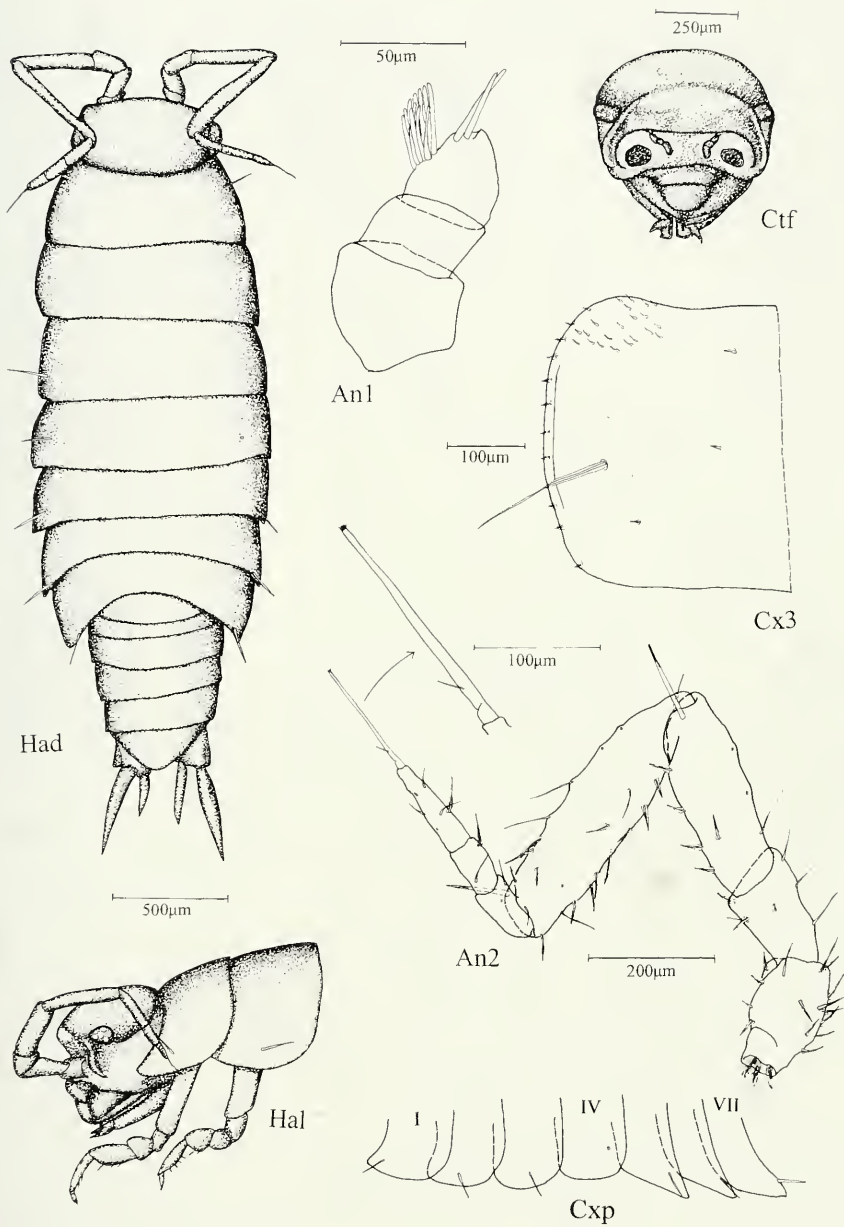

FIG. 8

*Androdeloscia feistae* sp. n. holotype ♂ 3mm. An1 antennula; An2 antenna with detail of apical organ; Ctf cephalothorax in frontal view; Cxp coxal plates with position of noduli laterales; Cx3 coxal plate 3; Had habitus in dorsal view; Hal habitus in lateral view; Tel pleotelson.

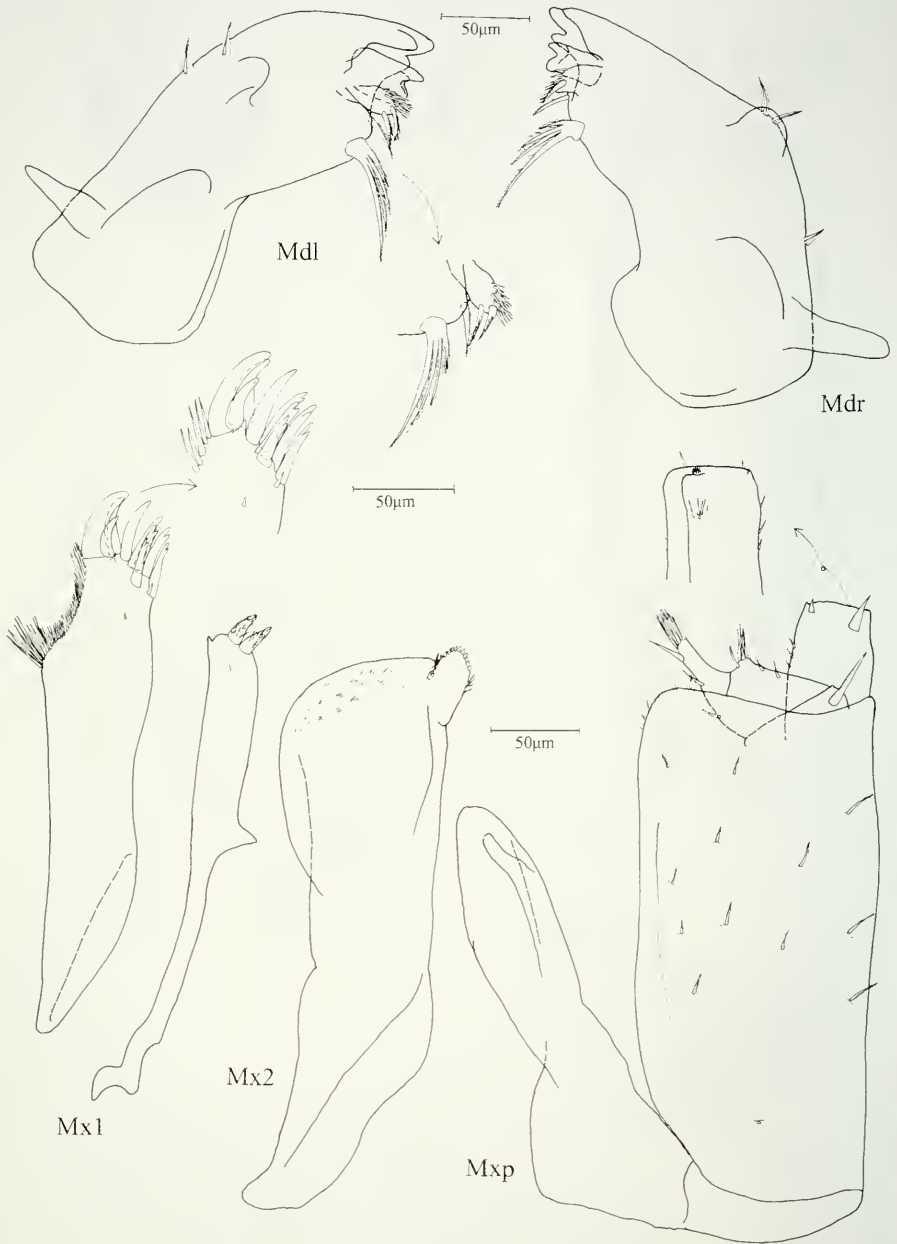

FIG. 9

*Androdeloscia feistae* sp. n. holotype ♂ 3mm. Mdl/r left and right mandible; Mxp maxilliped with detail of endite in rostral view; Mx1 maxillula with detail of apex of lateral endite; Mx2 maxilla.

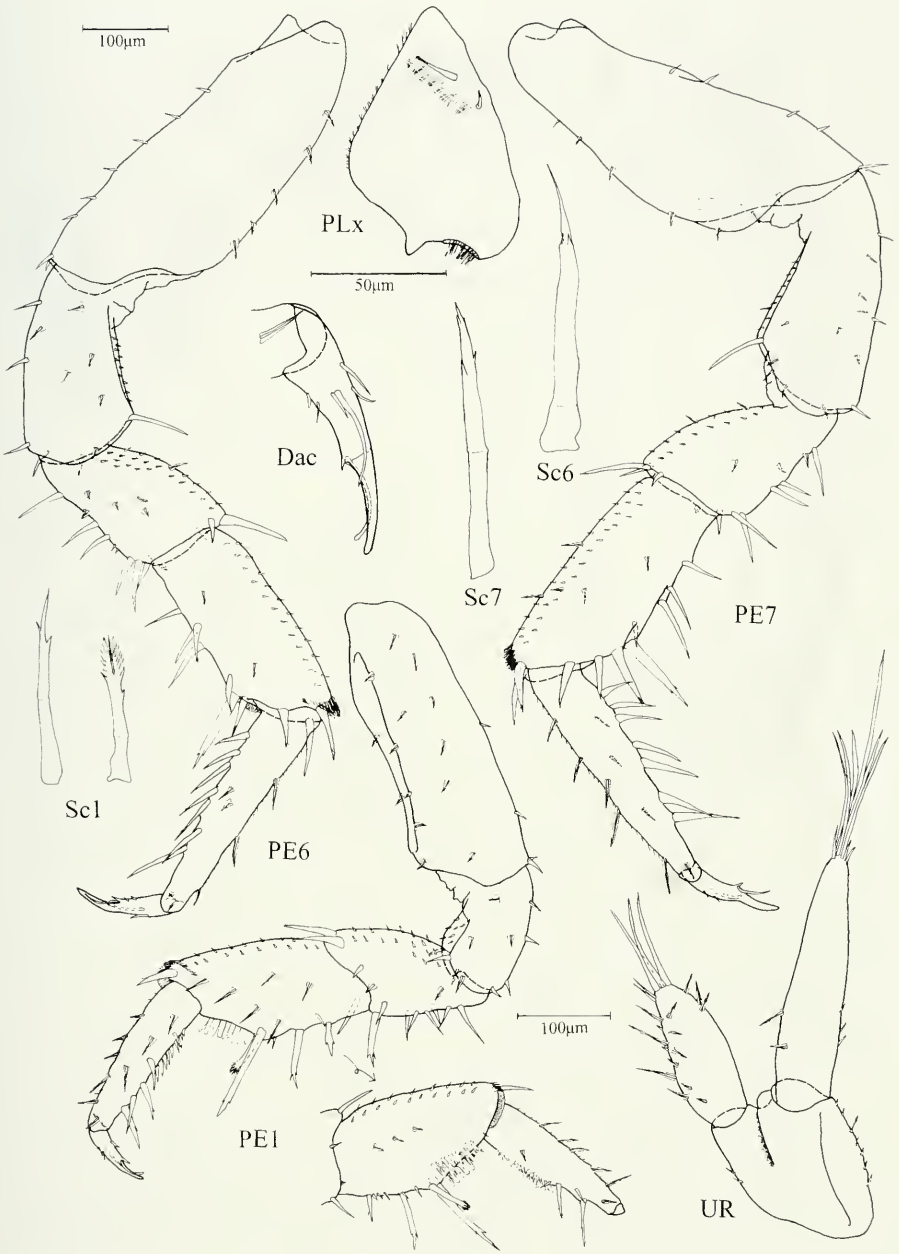

FIG. 10

*Androdeloscia feistae* sp. n. holotype ♂ 3mm. Dac dactylus 1 in rostral view; PE1-7 pereopods 1, 6, 7 (caudal view) with carpus 1 in rostral view; PLx pleopod 5 exopodite of female (Paratype 3.5mm); Sc1 ornamental and medial sensory spine of carpus 1; Sc6/7 sensory spines of carpus 6/7; UR uropod.

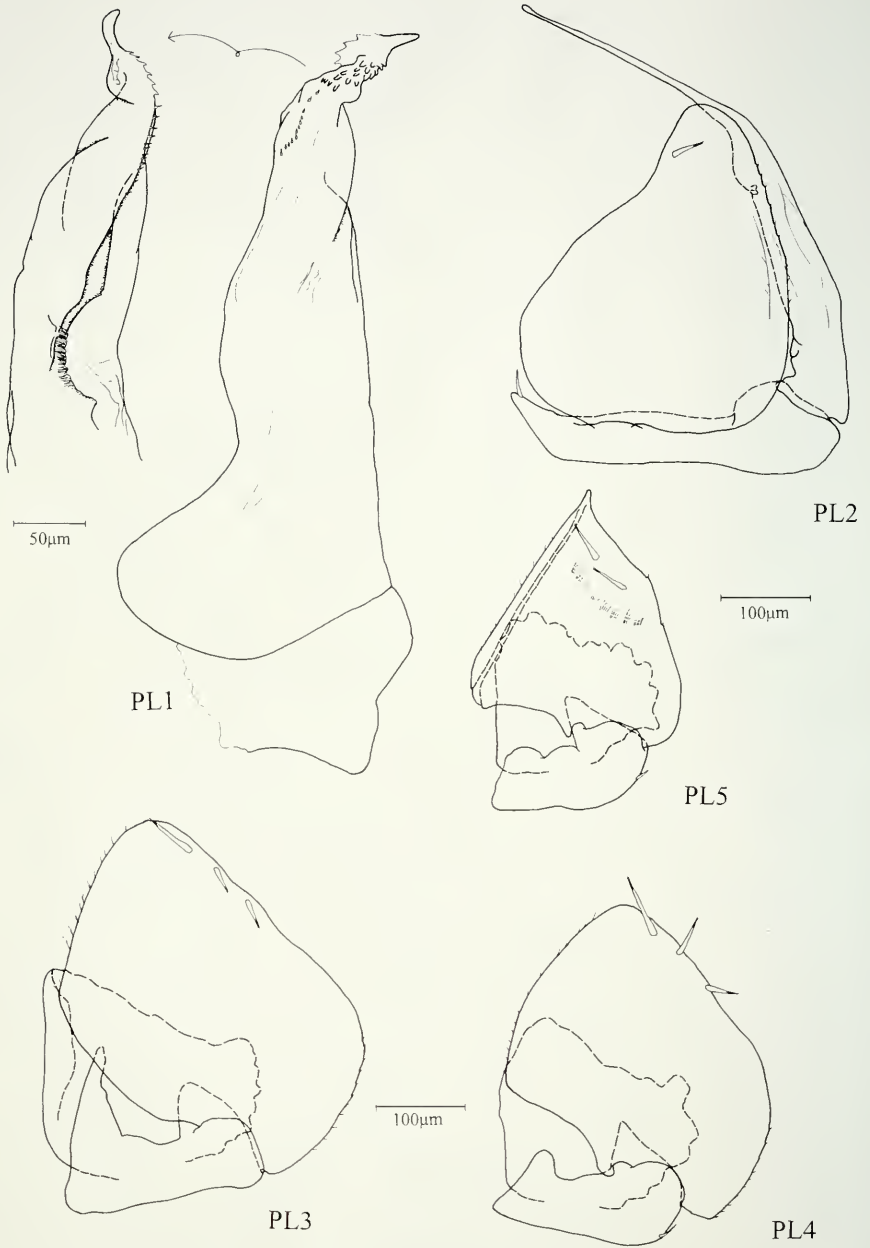

FIG. 11

*Androdeloscia feistae* sp. n. holotype ♂ 3mm. PL1-5 pleopods 1-5, rostral view with detail of endopodite 1 in caudal view.

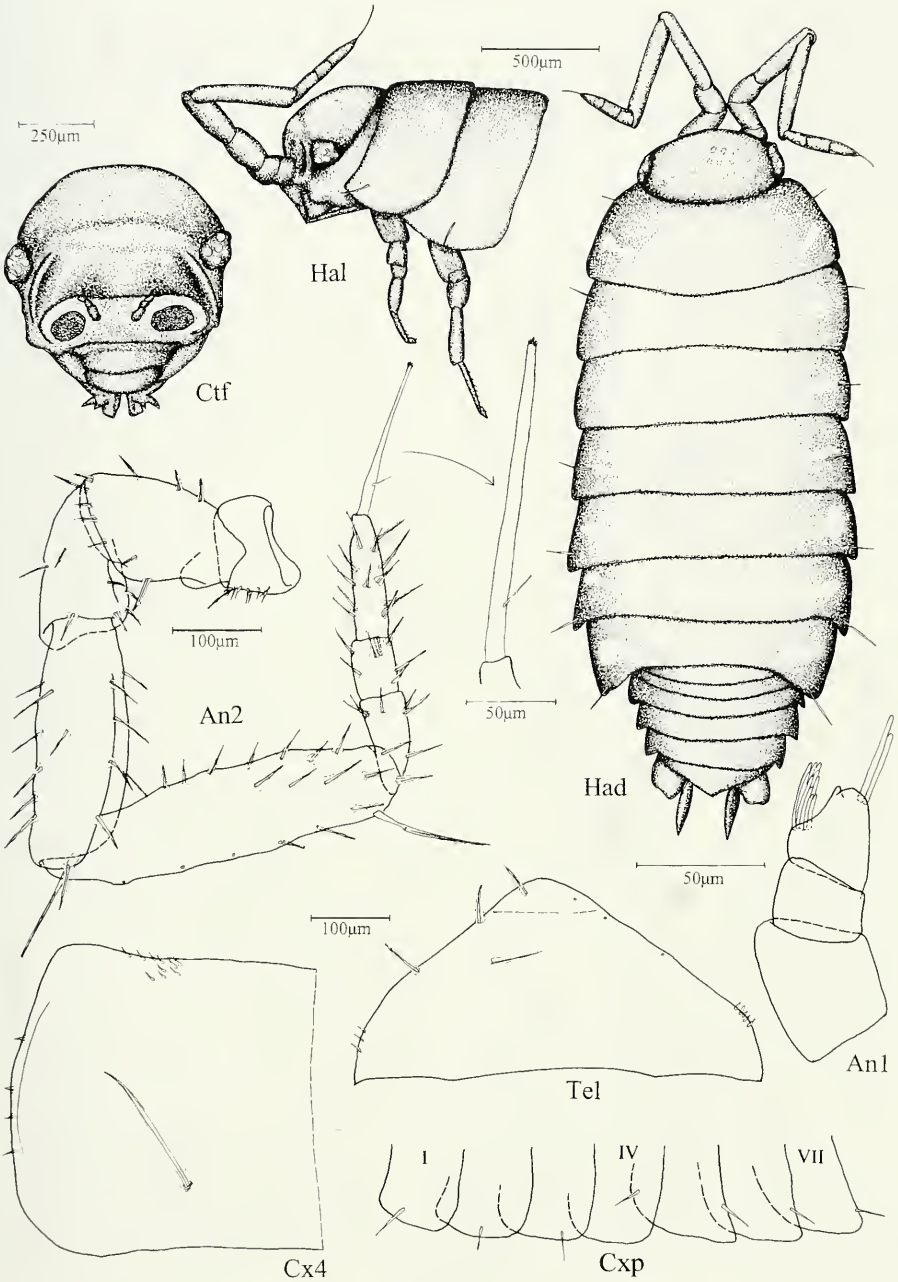

FIG. 12

*Androdeloscia plicatipes* sp. n. holotype ♂ 3mm. An1 antennula; An2 antenna with detail of apical organ; Ctf cephalothorax in frontal view; Cxp coxal plates with position of noduli laterales; Cx4 coxal plate 4; Had habitus in dorsal view; Hal habitus in lateral view; Tel pleotelson.

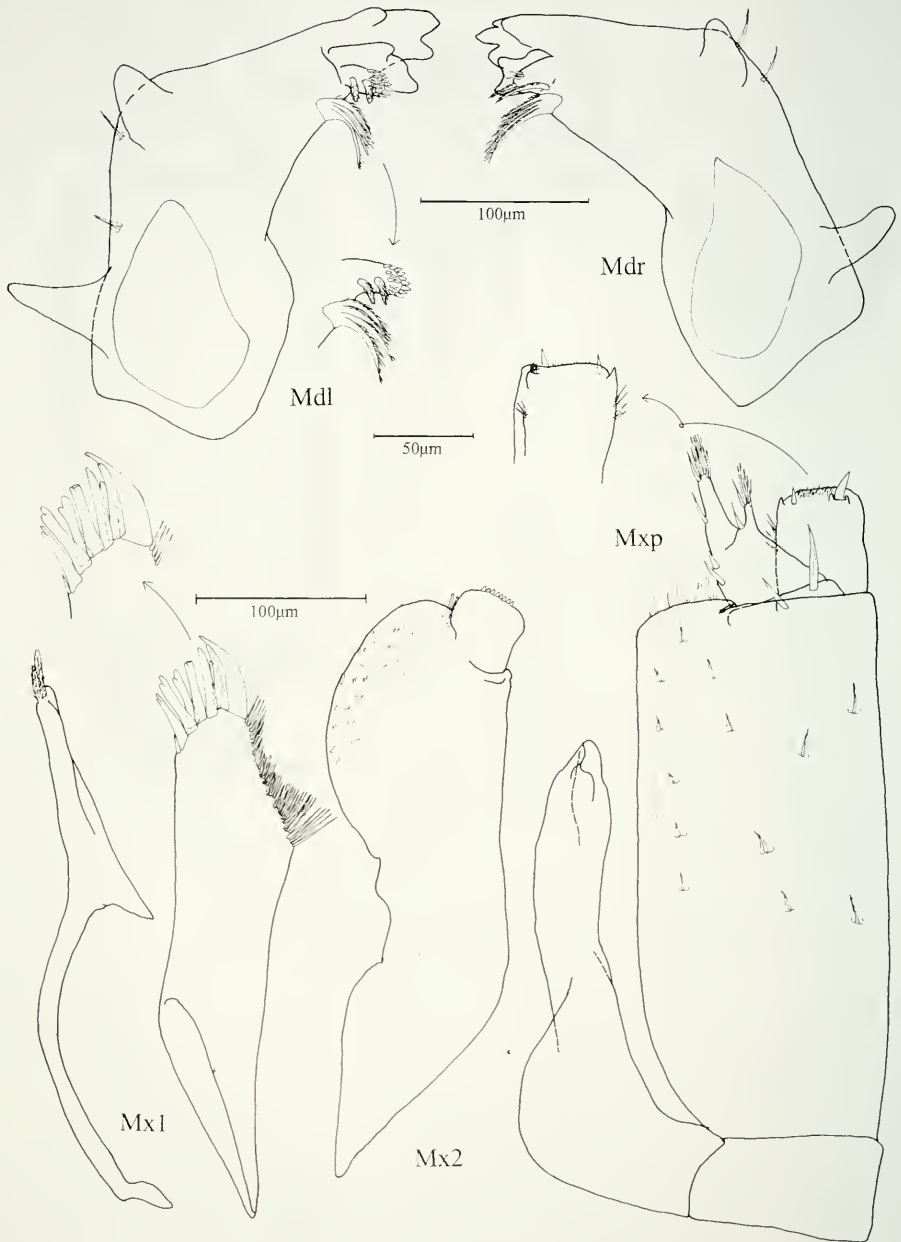

FIG. 13

*Androdeloscia plicatipus* sp. n. holotype ♂ 3mm. Mdl/r left and right mandible; Mxp maxilliped with detail of endite in rostral view; Mx1 maxillula with detail of apex of lateral endite; Mx2 maxilla.



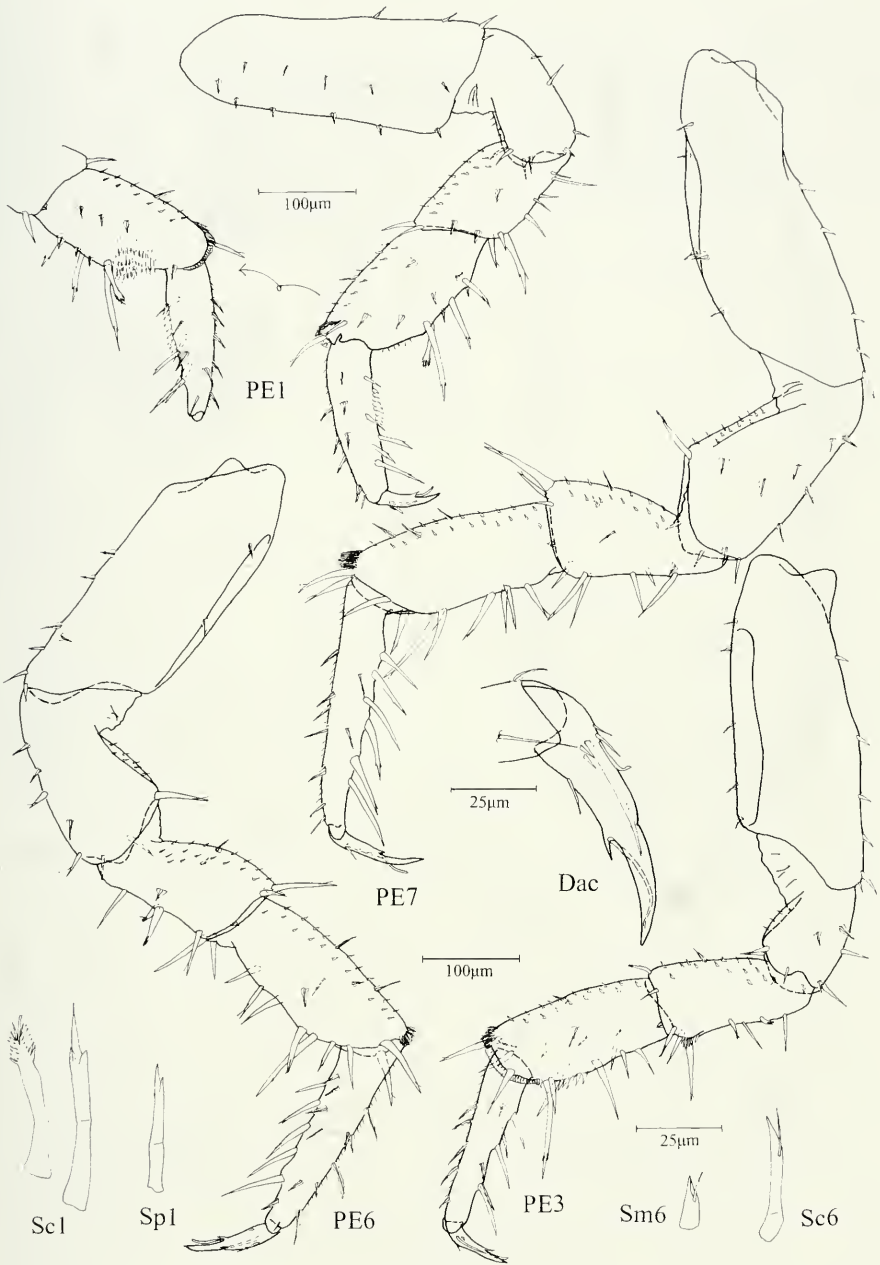

FIG. 14

*Androdeloscia plicatipus* sp. n. holotype ♂ 3mm. Dac dactylus 1 in rostral view; PE1-7 pereopods 1, 3, 6, 7 (caudal view), with detail of carpus 1 in rostral view; Sc1 ornamental sensory spine of carpus 1; Sc6 sensory spine of carpus 6; Sm6 sensory spine of merus 6; Sp1 distal sensory spine of propus 1.

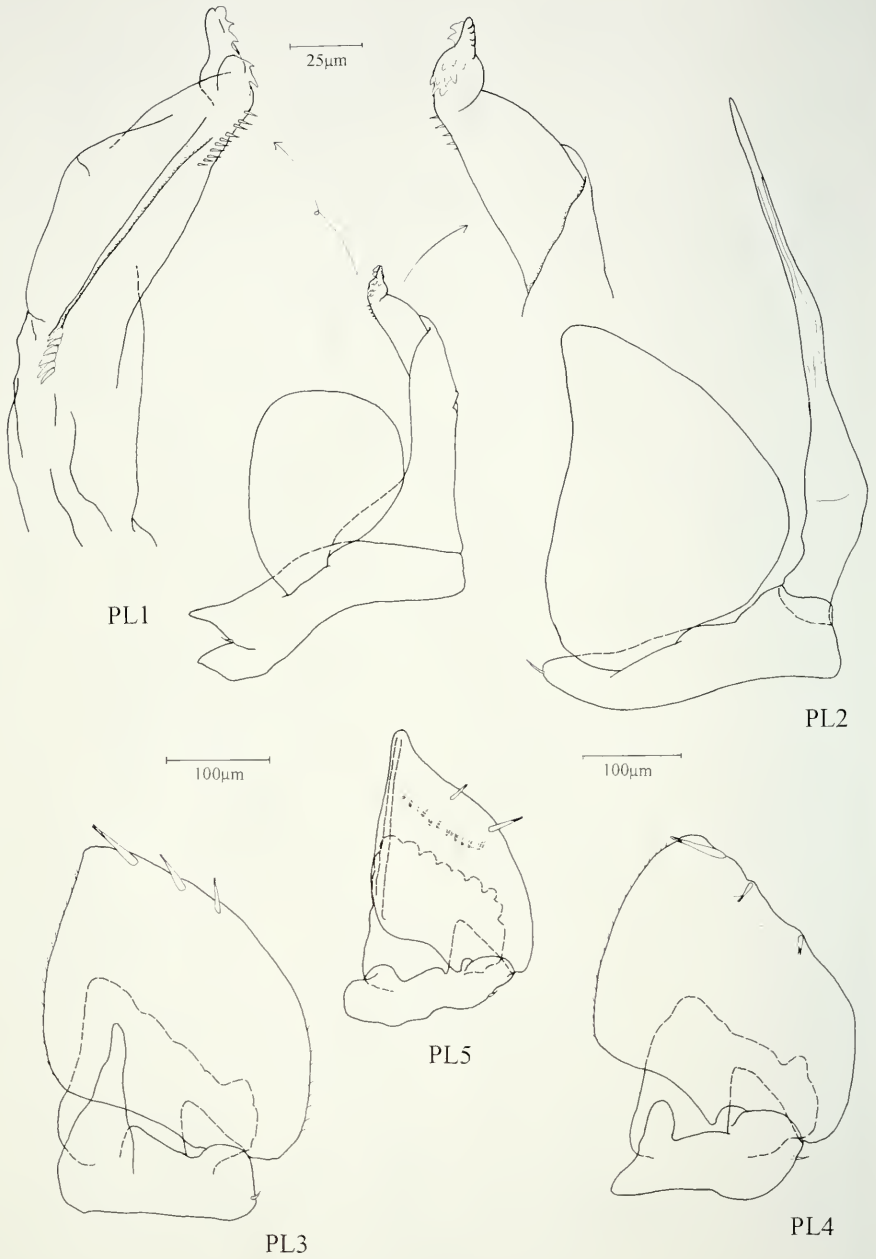

FIG. 15

*Androdeloscia plicatipus* sp. n. holotype ♂ 3mm. PL1-5 pleopods 1-5, rostral view, with details of endopodite 1 in caudal and rostral view.

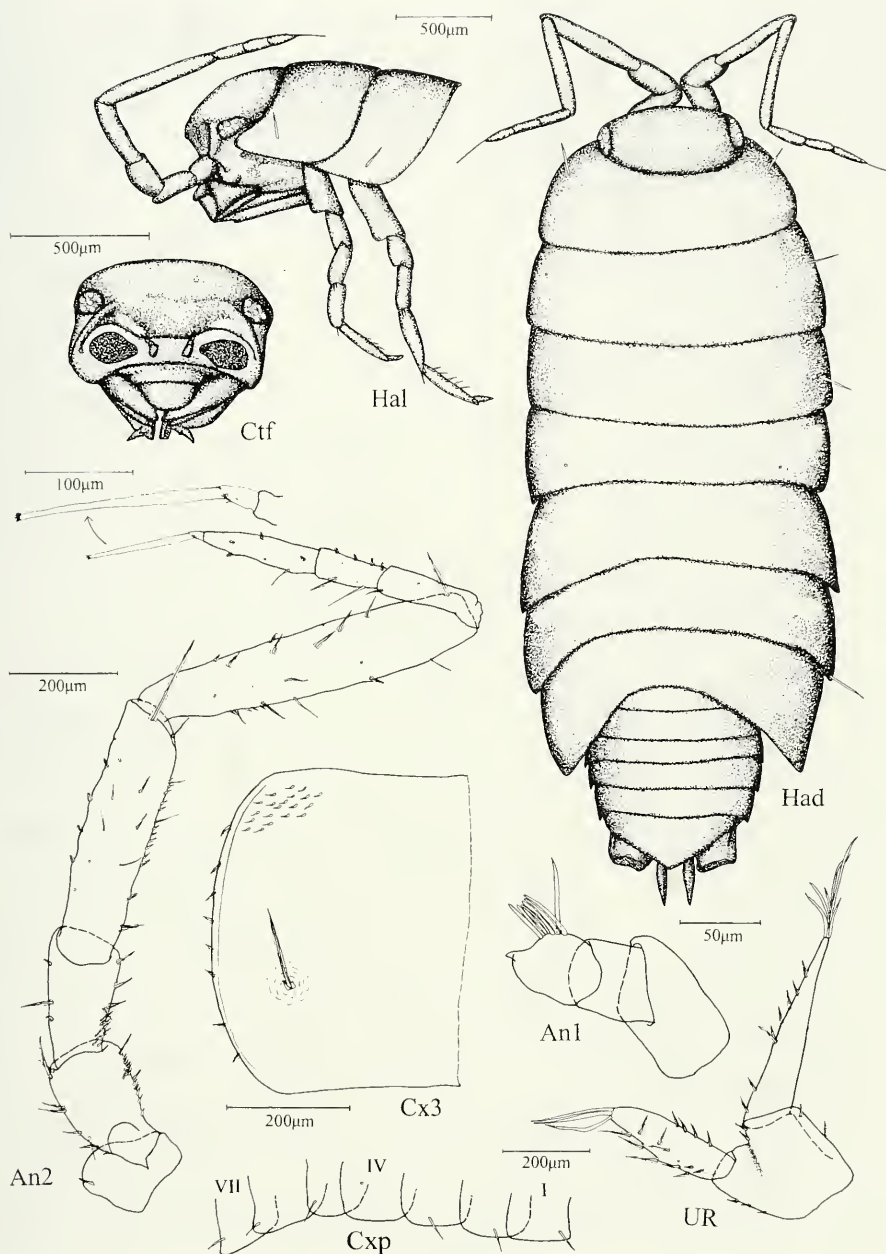

FIG. 16

*Androdeloscia taitii* sp. n. holotype ♂ 4mm. An1 antennula; An2 antenna with detail of apical organ; Ctf cephalothorax in frontal view; Cxp coxal plates with position of noduli laterales; Cx3 coxal plate 3; Had habitus in dorsal view; Hal habitus in lateral view; UR uropod.

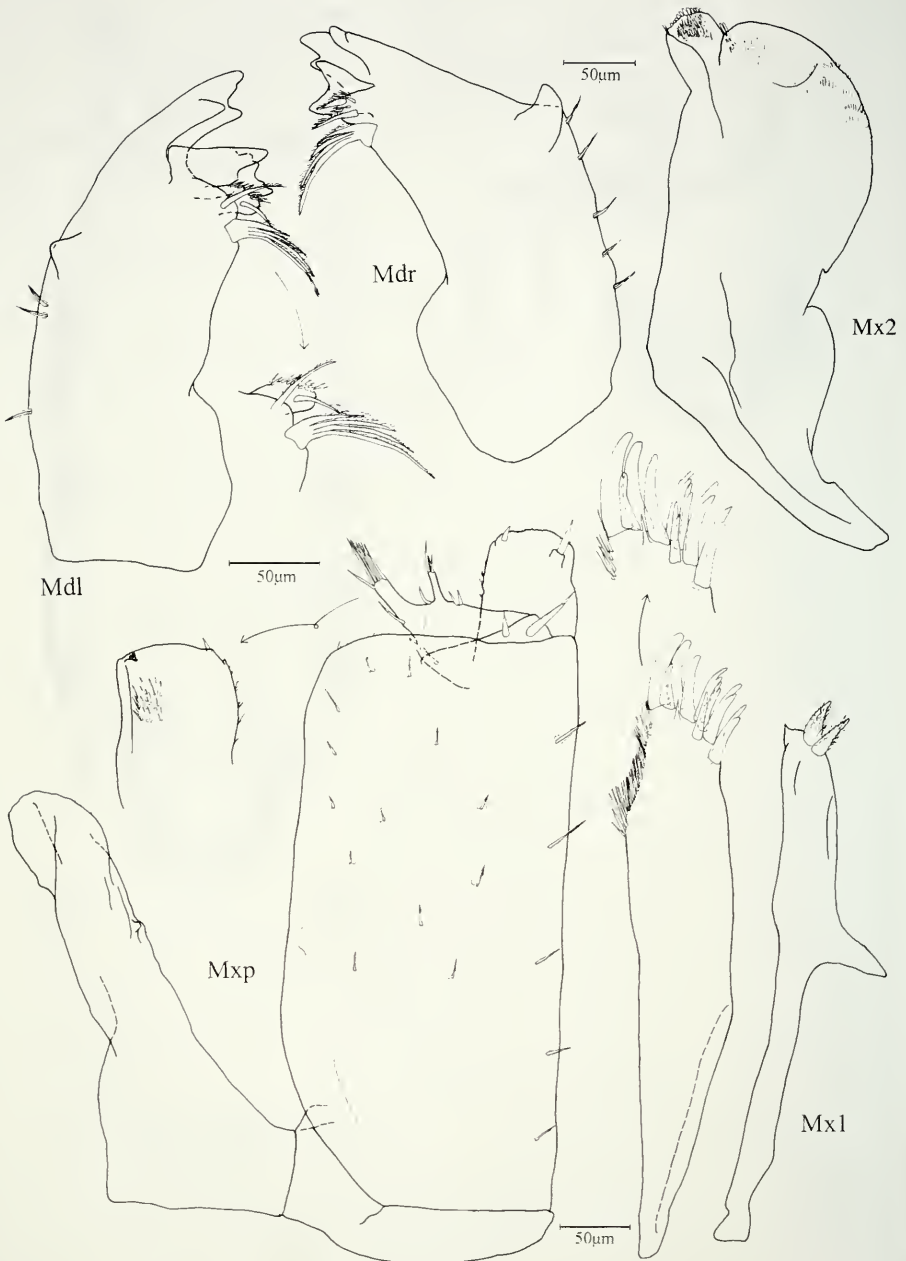

FIG. 17

*Androdeloscia taitii* sp. n. holotype ♂ 4mm. Mdl/r left and right mandible; Mxp maxilliped with detail of endite in rostral view; Mx1 maxillula with detail of apex of lateral endite; Mx2 maxilla.

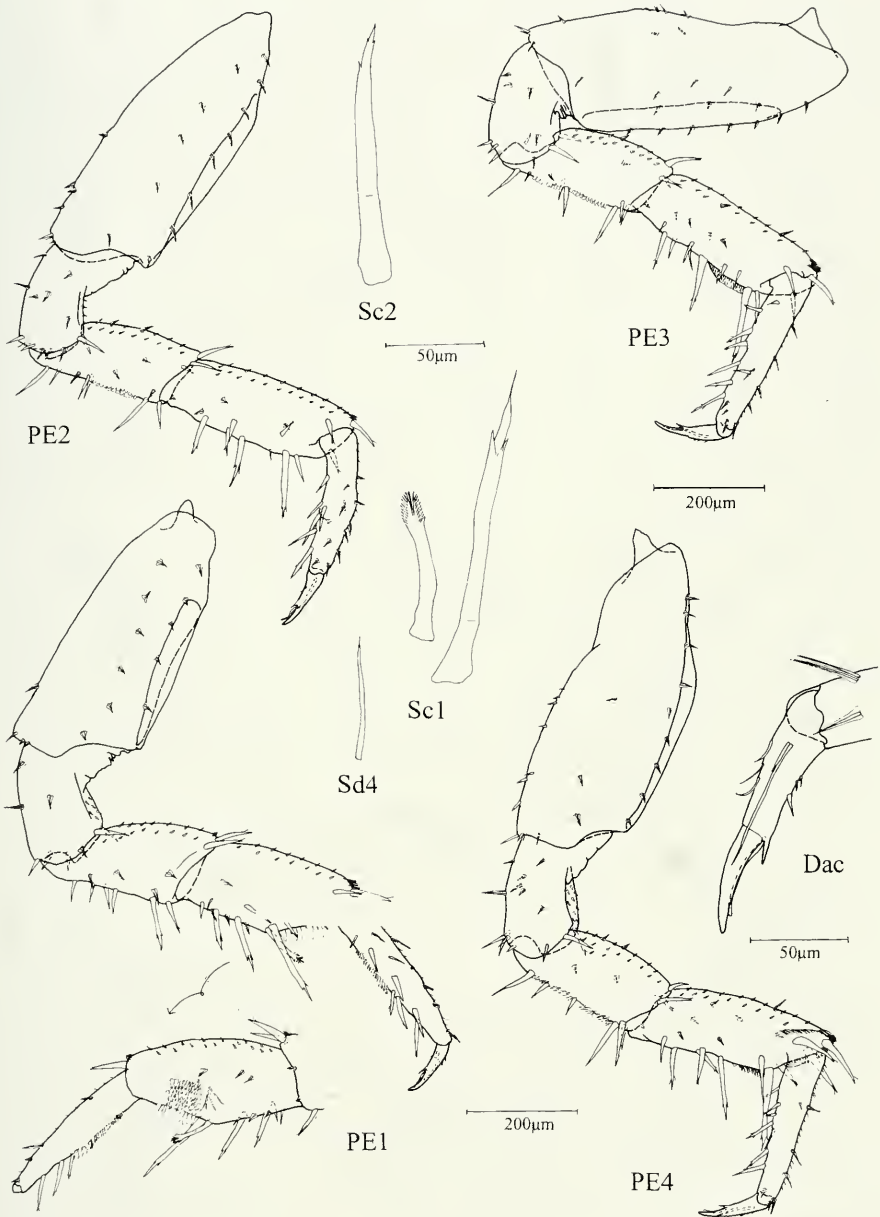

FIG. 18

*Androdeloscia taitii* sp. n. holotype ♂ 3.5mm. Dac dactylus 4 in rostral view; PE1-4 pereopods 1-4 (caudal view), with detail of carpus 1 in rostral view; Sc1 ornamental and longest sensory spine of carpus 1; Sc2 sensory spine of carpus 2; Sd4 dactylar seta of dactylus 4.

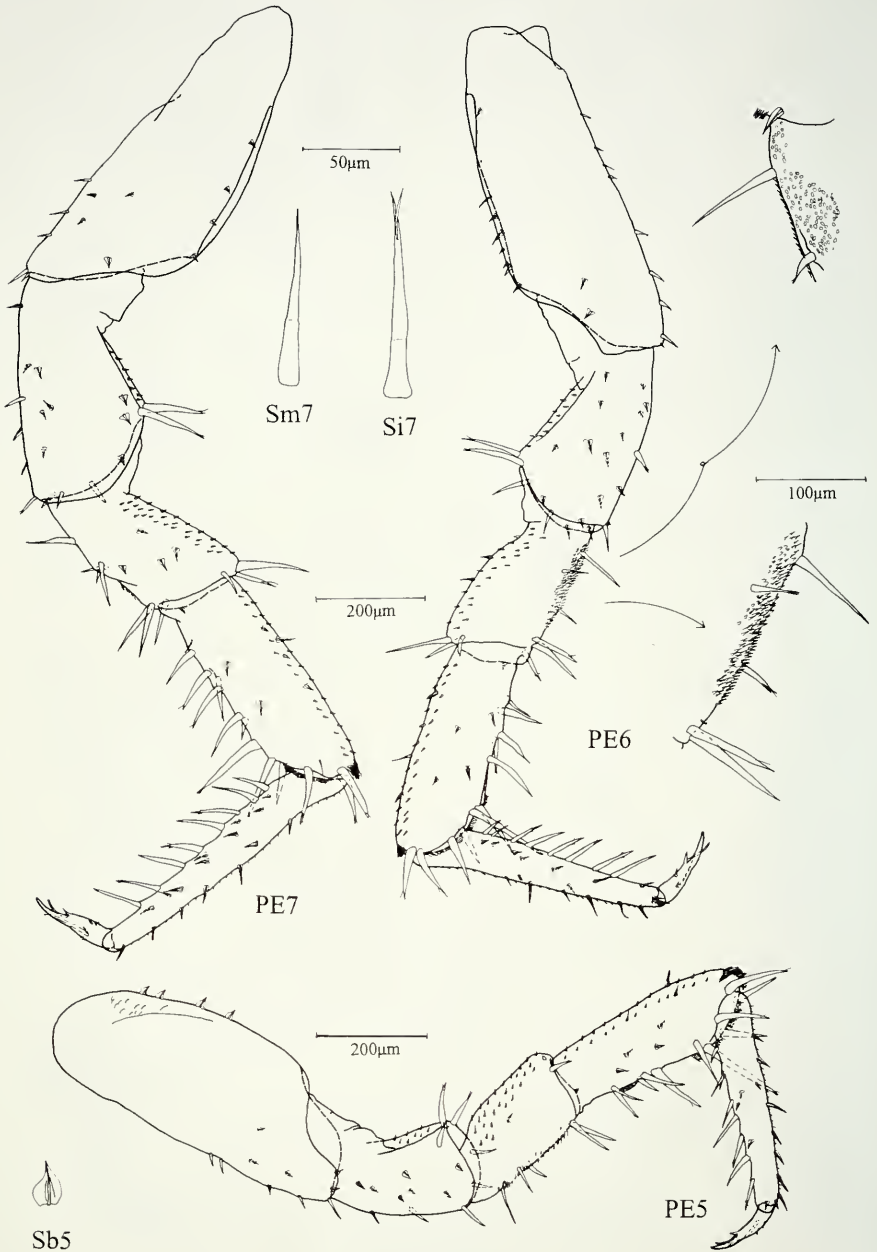

FIG. 19

*Androdeloscia taitii* sp. n. holotype ♂ 4mm. PE5-7 pereopods 5-7 (caudal view), with details of merus 6 in rostral and caudal view; Si7 lateral sensory spine of ischium 7; Sm7 sensory spine of merus 7; Sb5 tricorn-like seta of basis 5.

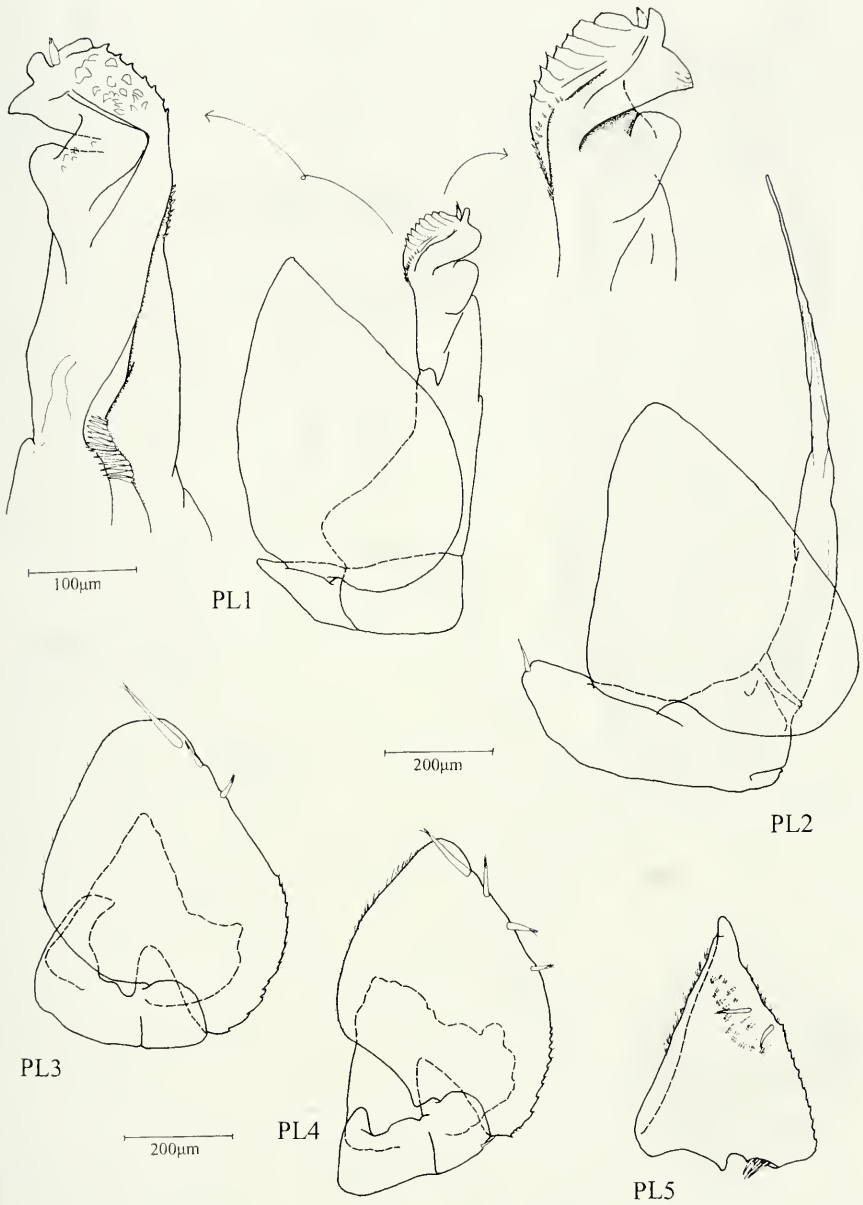

FIG. 20

*Androdeloscia taitii* sp. n. holotype ♂ 4mm. PL1-5 pleopods 1-5, rostral view, with details of endopodite 1 in caudal and rostral view.

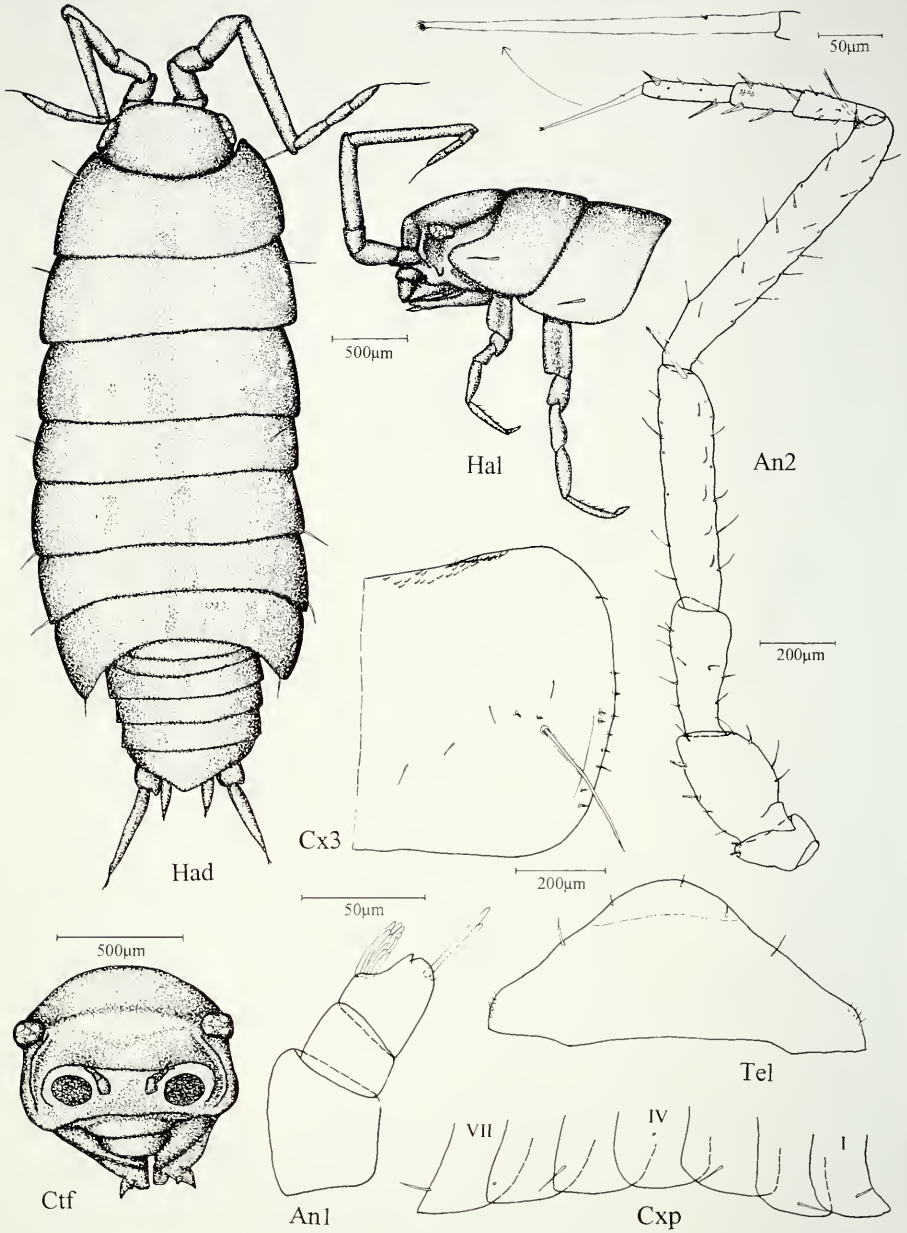

FIG. 21

*Androdeloscia merolobata* sp. n. holotype ♂ 5mm. An1 antennula; An2 antenna with detail of apical organ; Ctf cephalothorax in frontal view; Cxp coxal plates with position of noduli laterales; Cx3 coxal plate 3; Had habitus in dorsal view; Hal habitus in lateral view; Tel pleotelson.





FIG. 22

*Androdeloscia merolobata* sp. n. holotype ♂ 5mm. Mdl/r left and right mandible; Mxp maxilliped with detail of endite in rostral view; Mx1 maxillula with detail of apex of lateral endite in caudal and rostral view; Mx2 maxilla.

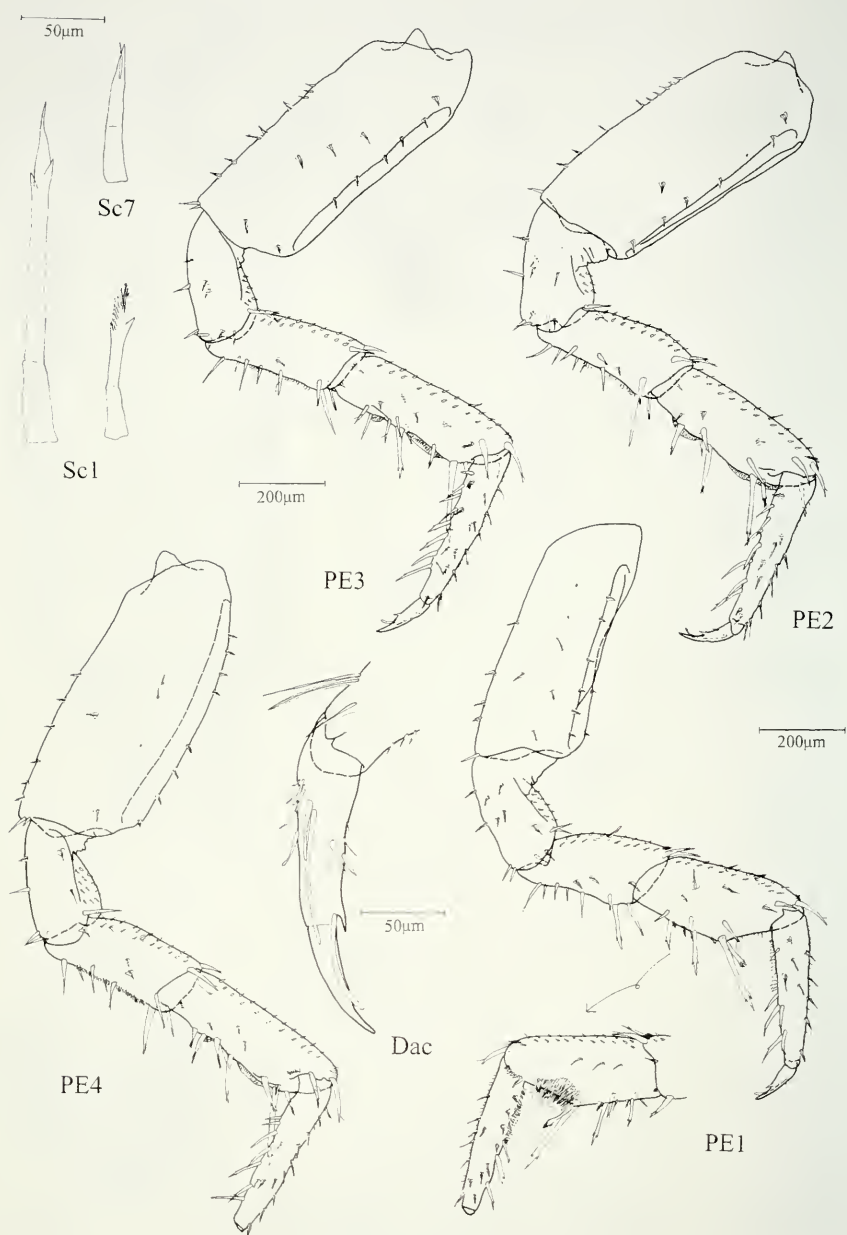

FIG. 23

*Androdeloscia merolobata* sp. n. holotype ♂ 5mm. Dac dactylus 4 in rostral view; PE1-4 pereopods 1-4 (caudal view), with detail of carpus 1 in rostral view; Sc1 ornamental and longest sensory spine of carpus 1; Sc7 sensory spine of carpus 7.

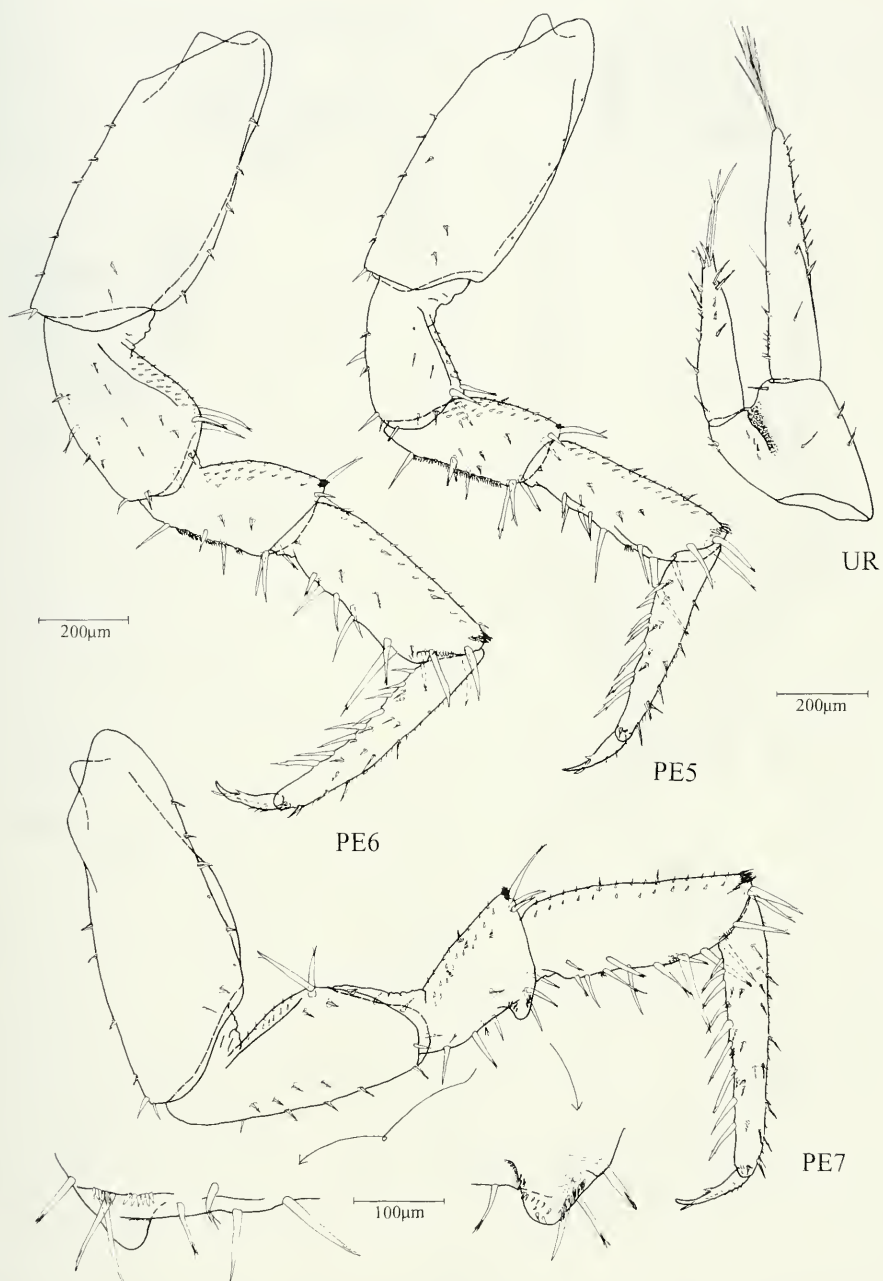

FIG. 24

*Androdeloscia merolobata* sp. n. holotype ♂ 5mm. PE5-7 pereopods 5-7 (caudal view), with details of lobes on merus 7 in rostral and caudal view; UR uropod.

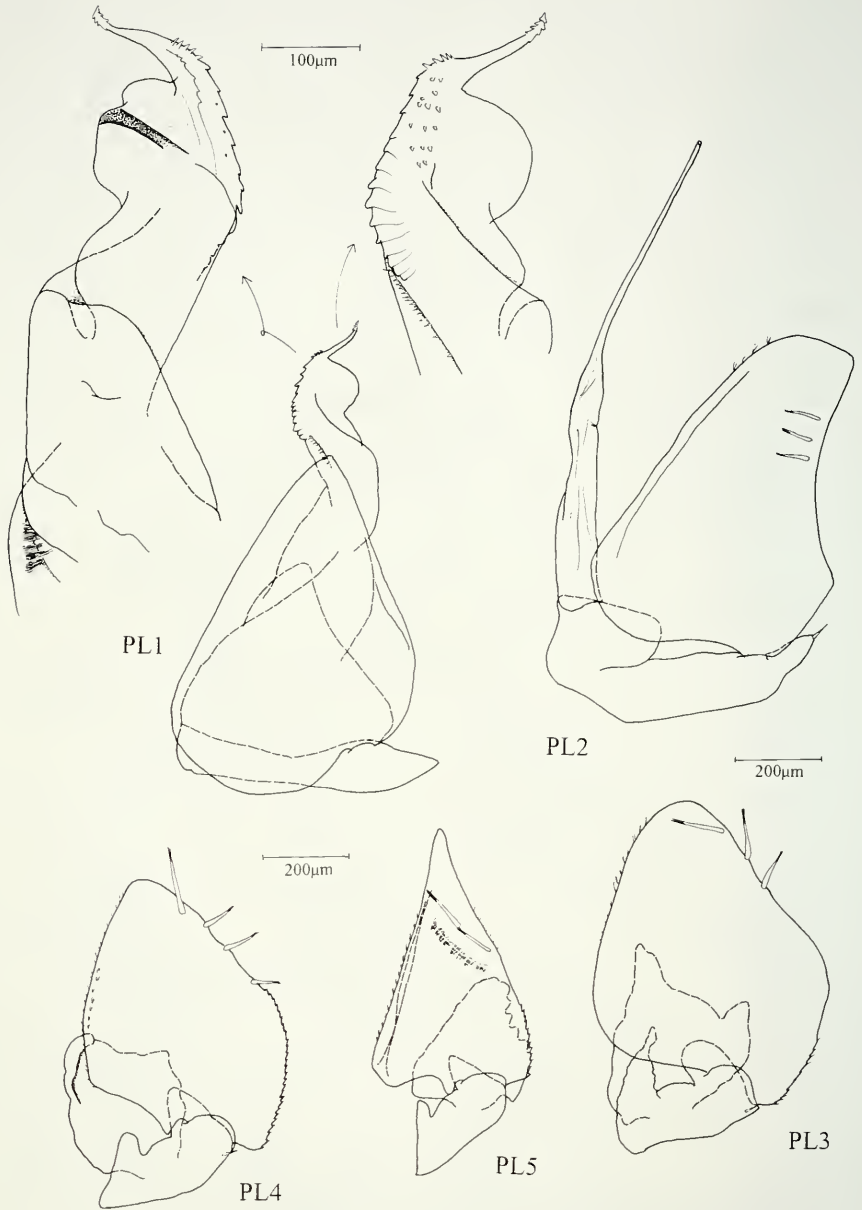

FIG. 25

*Androdeloscia merolobata* sp. n. holotype ♂ 5mm. PL1-5 pleopods 1-5, rostral view, with details of endopodite 1 in caudal and rostral view.

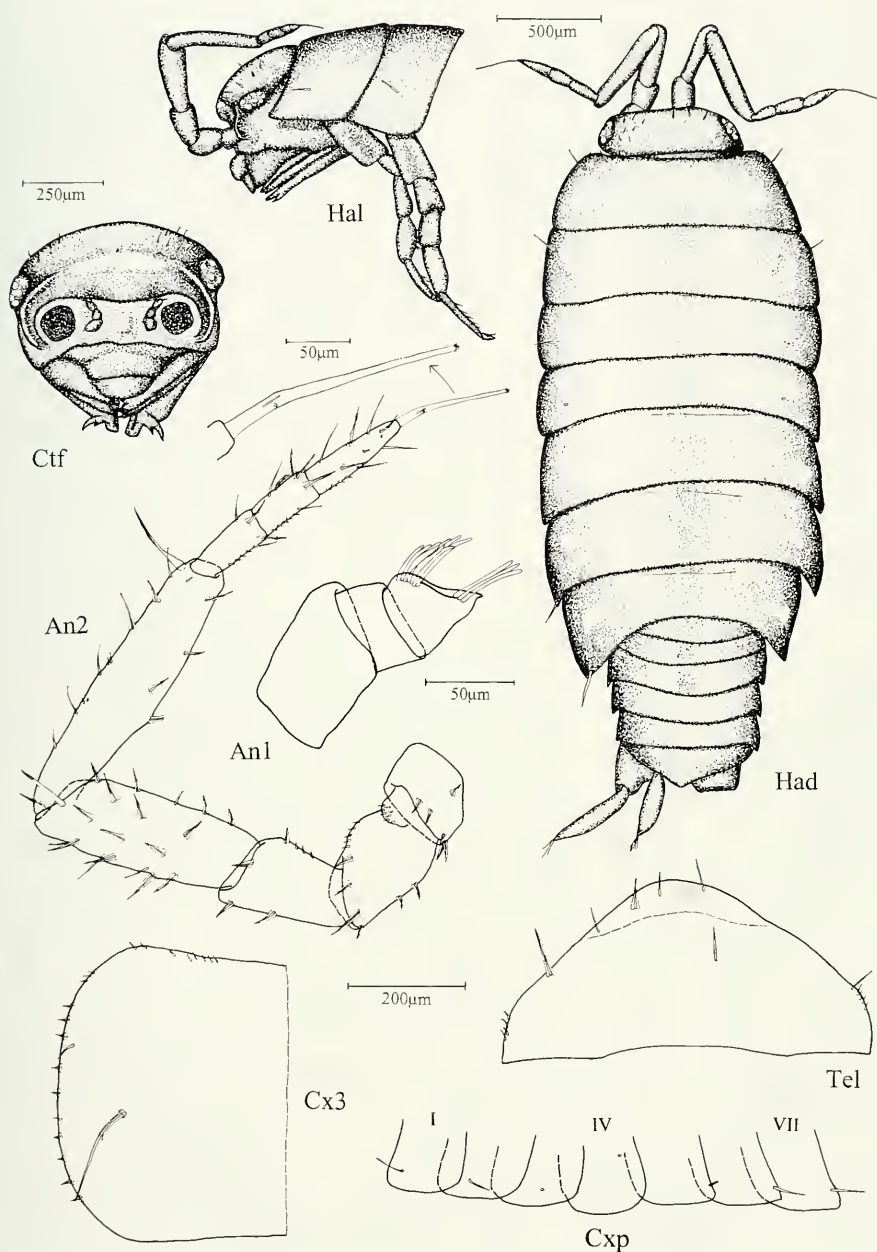

FIG. 26

*Androdeloscia longiunguis* sp. n. holotype ♂ 4mm. An1 antennula; An2 antenna with detail of apical organ; Ctf cephalothorax in frontal view; Cxp coxal plates with position of noduli laterales; Cx3 coxal plate 3; Had habitus in dorsal view; Hal habitus in lateral view.

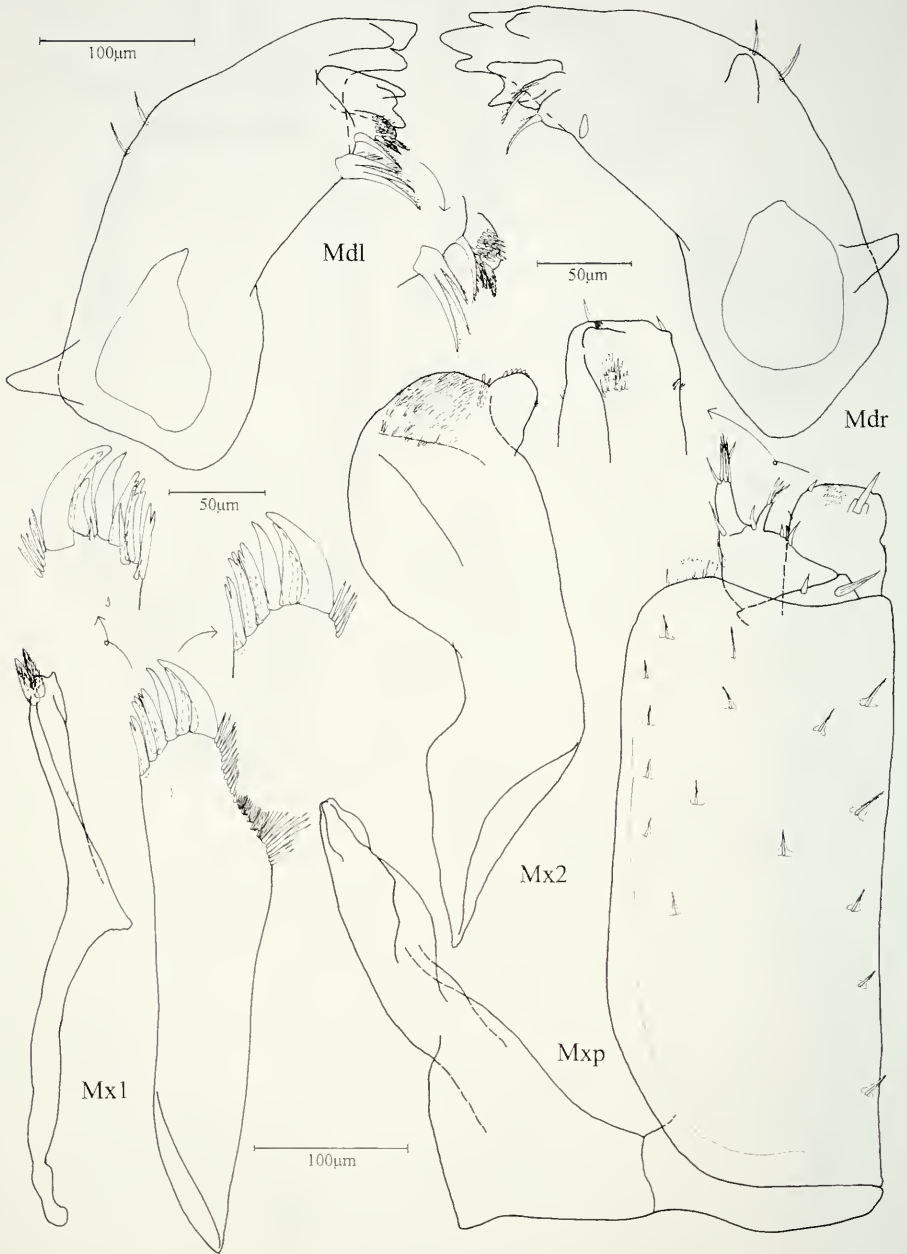

FIG. 27

*Androdeloscia longiunguis* sp. n. holotype ♂ 4mm. Mdl/r left and right mandible; Mxp maxilliped with detail of endite in rostral view; Mx1 maxillula with detail of apex of lateral endite in caudal and rostral view; Mx2 maxillula.

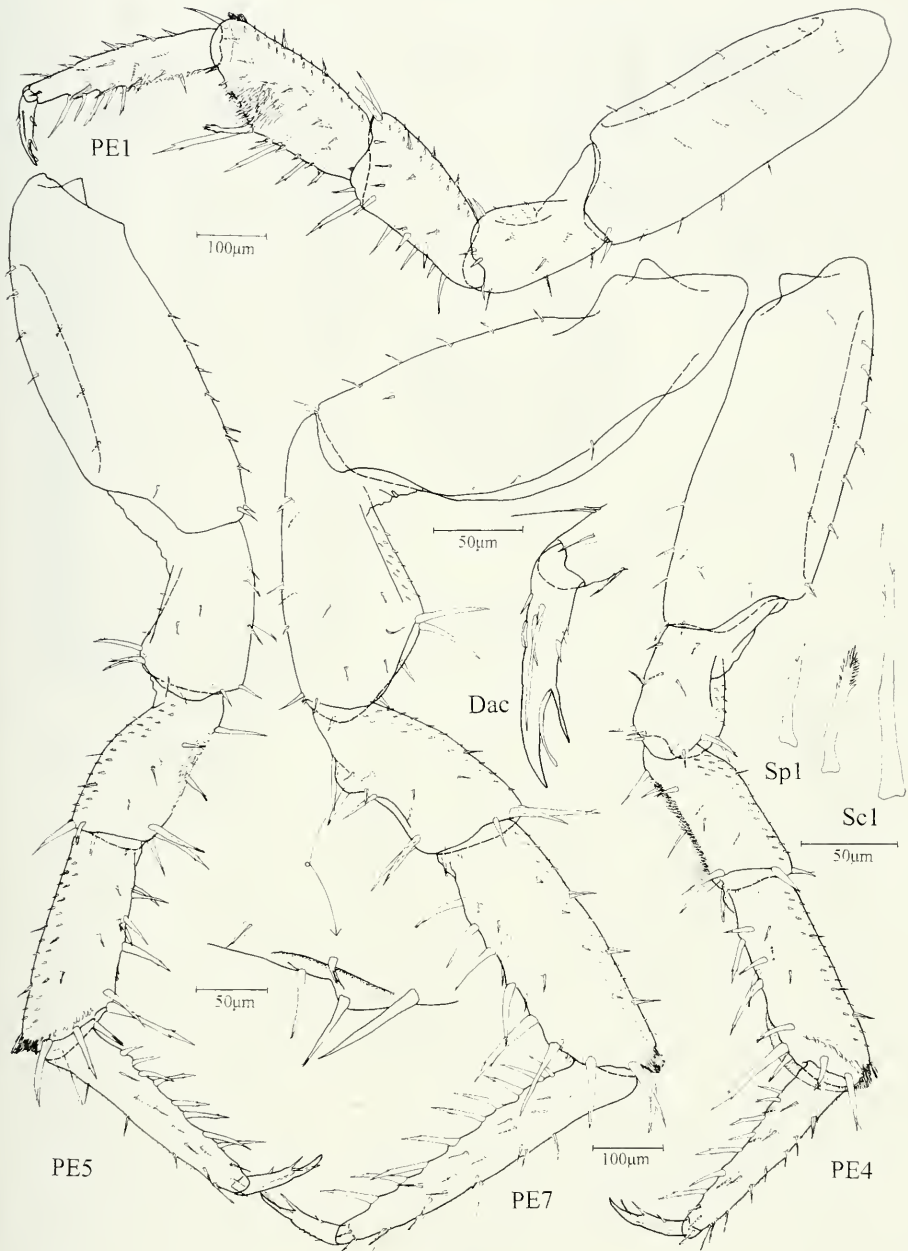

FIG. 28

*Androdeloscia longiunguis* sp. n. holotype ♂ 4mm. Dac dactylus 4 in rostral view; PE1-7 pereopods 1(rostral view), 4, 5, 7 (caudal view), with detail of merus 7 in rostral view; Scl ornamental and longest sensory spine of carpus 1; Sp1 distal sensory spine of propus 1.

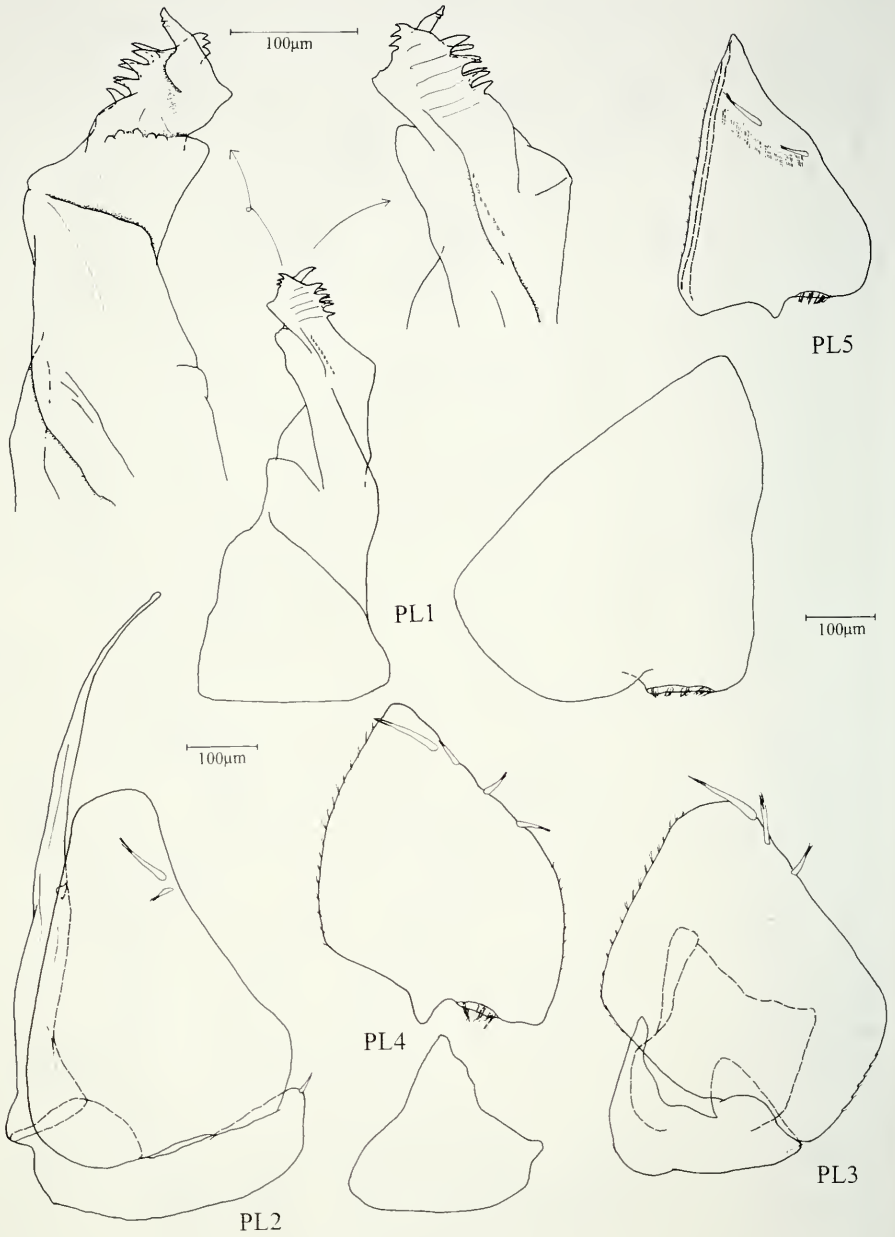

FIG. 29

*Androdeloscia longiunguis* sp. n. holotype ♂ 4mm. PL1-5 pleopods 1-5, rostral view, with details of endopodite 1 in caudal and rostral view.



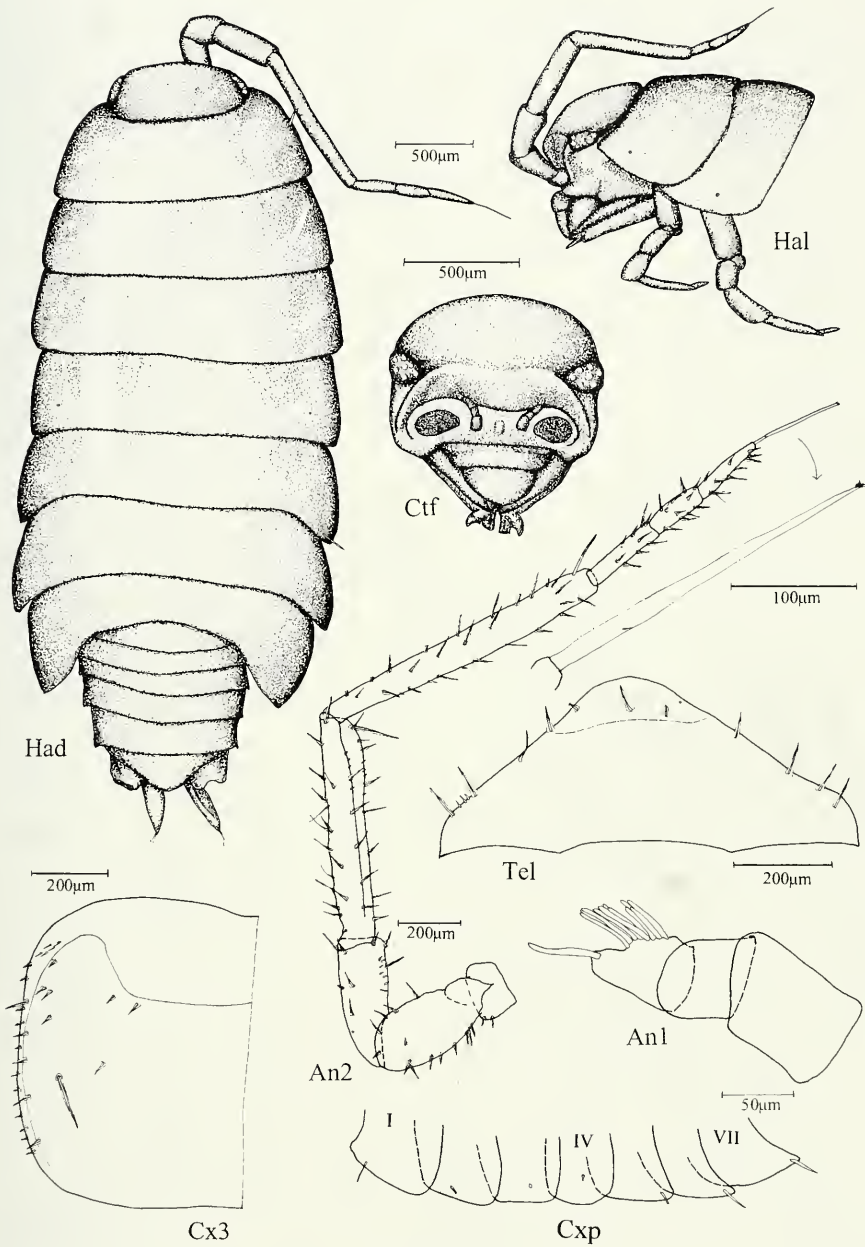

FIG. 30

*Androdeloscia ferrarai* sp. n. holotype ♂ 5mm. An1 antennula; An2 antenna with detail of apical organ; Ctf cephalothorax in frontal view; Cxp coxal plates with position of noduli laterales; Cx3 coxal plate 3; Had habitus in dorsal view; Hal habitus in lateral view; Tel pleotelson.

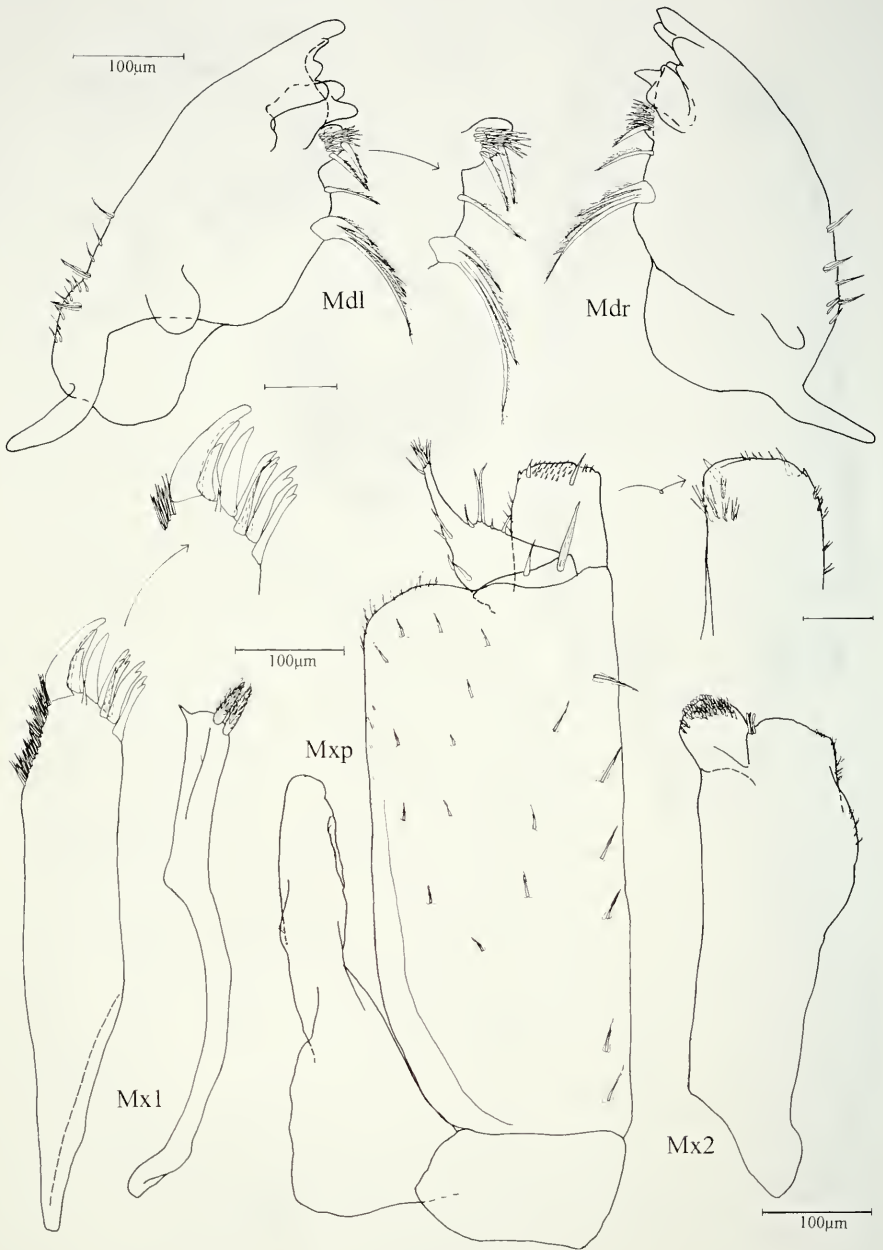

FIG. 31

*Androdeloscia ferrarai* sp. n. holotype ♂ 5mm. Mdl/r left and right mandible; Mxp maxilliped with detail of endite in rostral view; Mx1 maxillula with detail of apex of lateral endite; Mx2 maxilla.

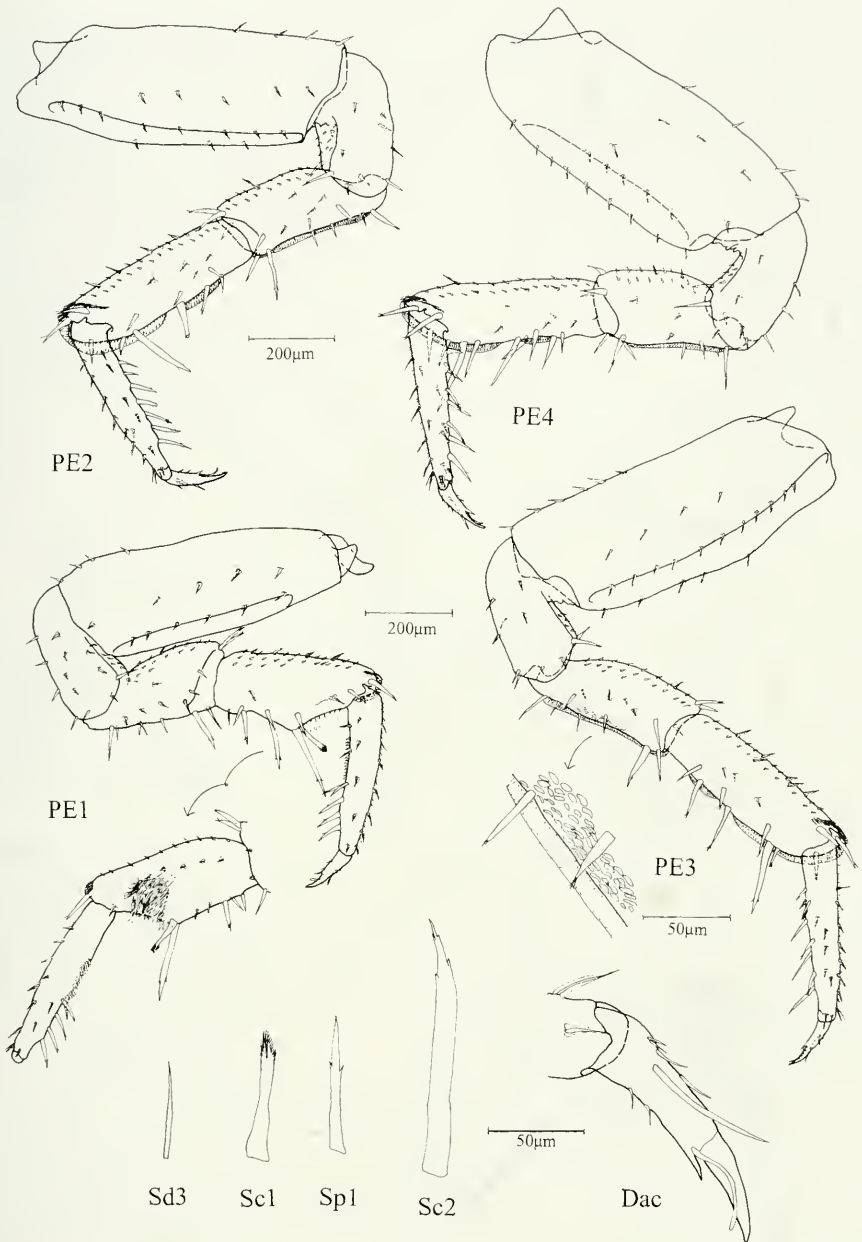

FIG. 32

*Androdeloscia ferrarai* sp. n. holotype ♂ 5mm. Dac dactylus 3 in rostral view; PE1-4 pereopods 1-4 (caudal view), with detail of carpus 1 in rostral view, and detail of merus 3; Sc1 ornamental and longest sensory spine of carpus 1; Sc2 sensory spine of carpus 2; Sd3 dactylar seta of dactylus 3; Sp1 distal sensory spine of propus 1.

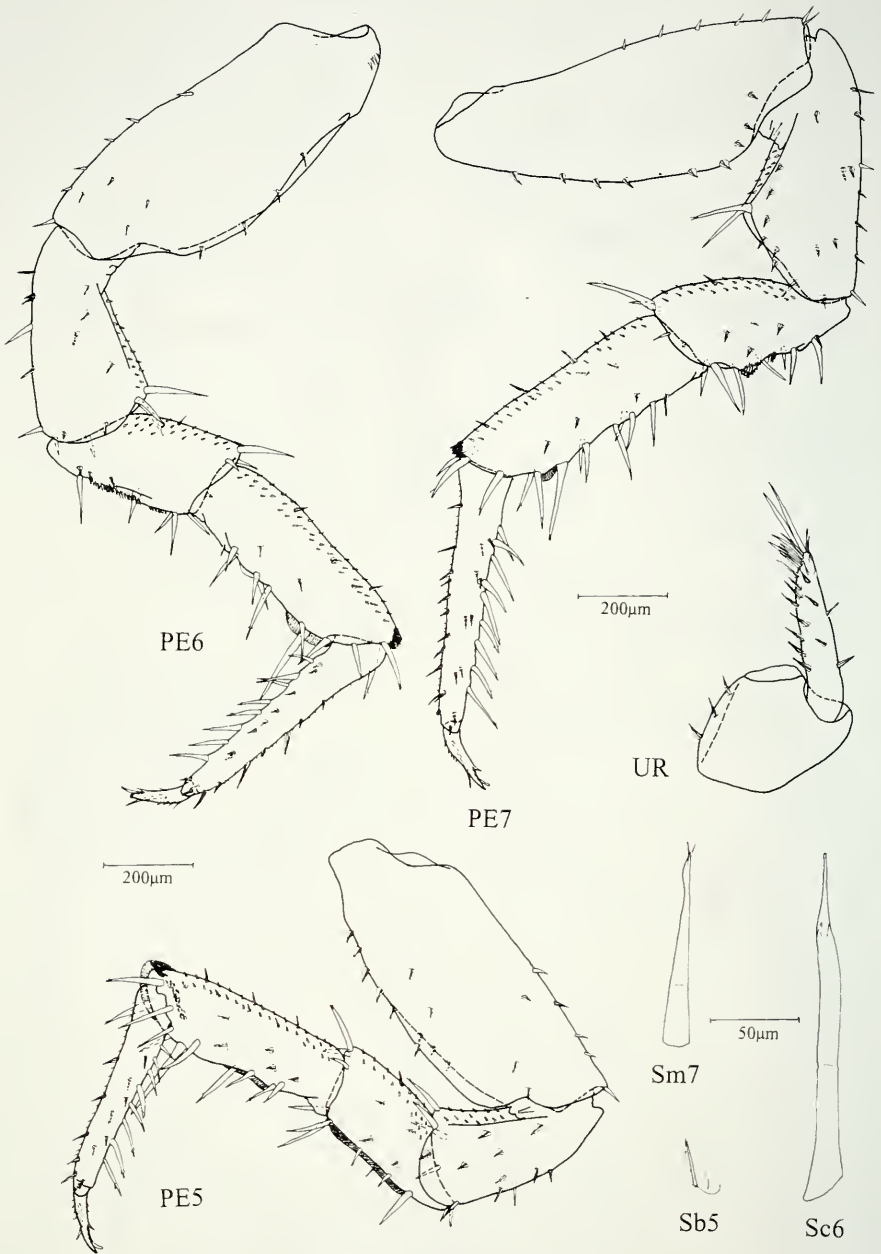

FIG. 33

*Androdeloscia ferrarai* sp. n. holotype ♂ 5mm. PE5-7 pereopods 5-7 (caudal view), with details of merus 6 in rostral and caudal view; Sb5 tricorn-like seta of basis 5; Sc6 lateral sensory spine of carpus 6; Sm7 sensory spine of merus 7; UR uropod.

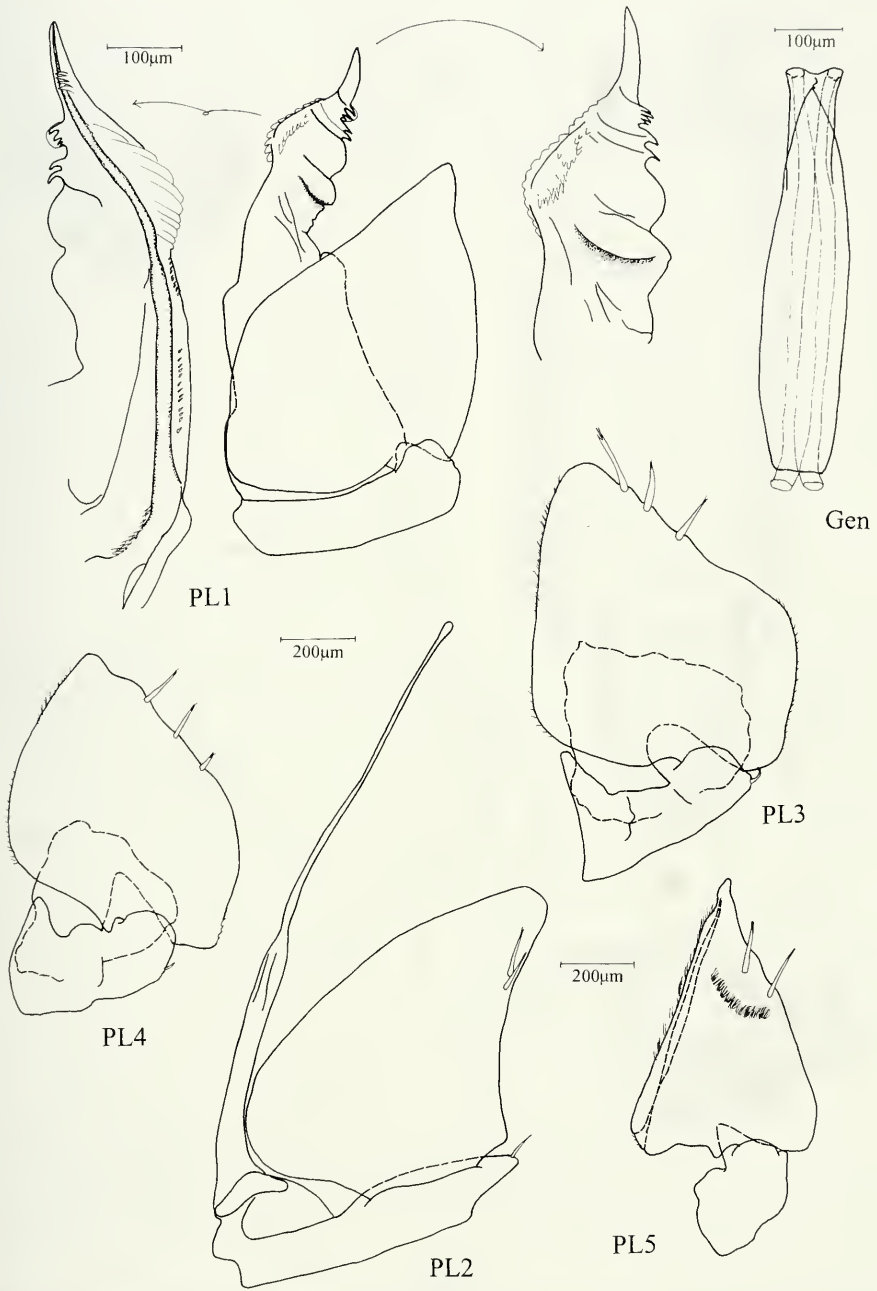

FIG. 34

*Androdeloscia ferrarai* sp. n. holotype ♂ 5mm. Gen genital papilla; PL1-5 pleopods 1-5, rostral view, with details of endopodite 1 in caudal and rostral view.

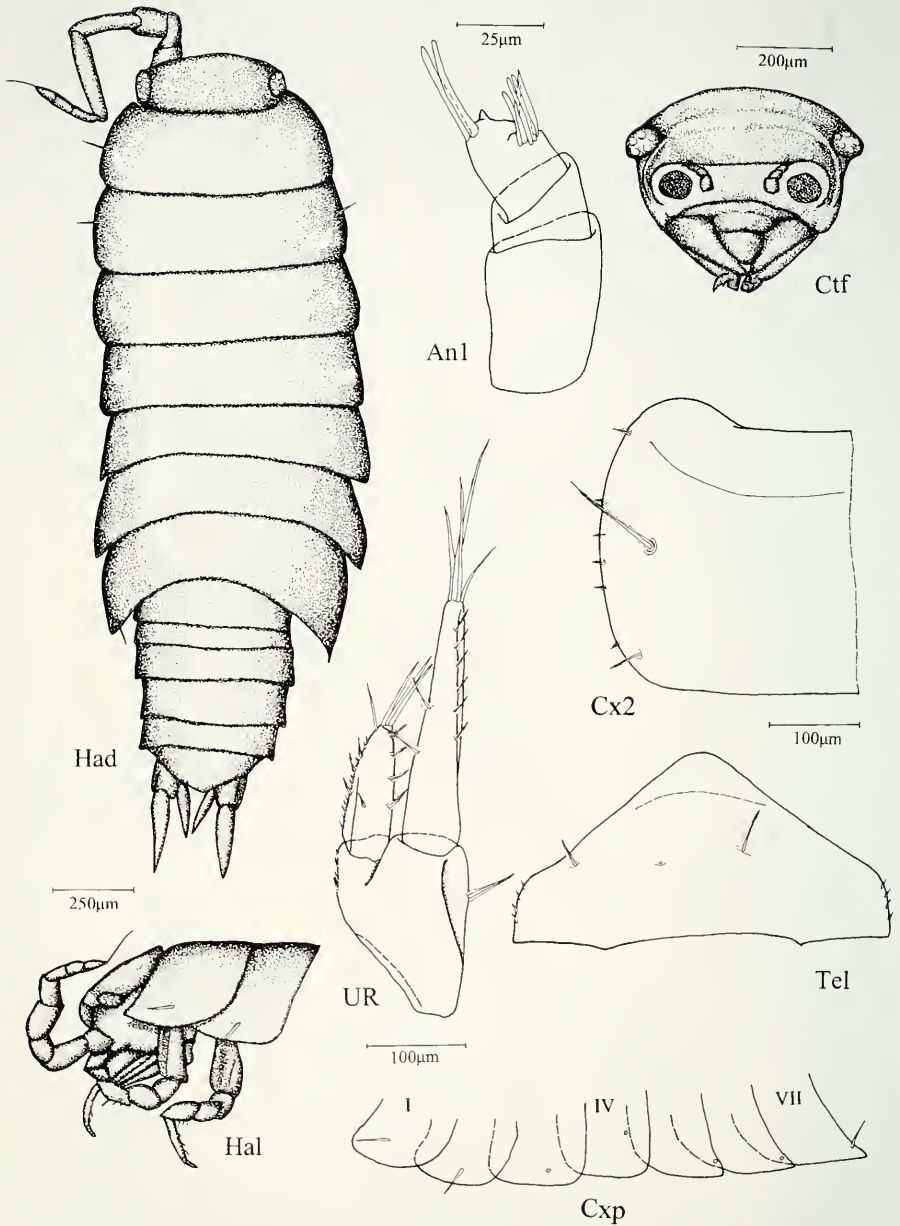

FIG. 35

*Androdeloscia poeppigi* sp. n. holotype ♂ 2.5mm. An1 antennula; Ctf cephalothorax in frontal view; Cxp coxal plates with position of noduli laterales; Cx2 coxal plate 2; Had habitus in dorsal view; Hal habitus in lateral view; UR uropod.

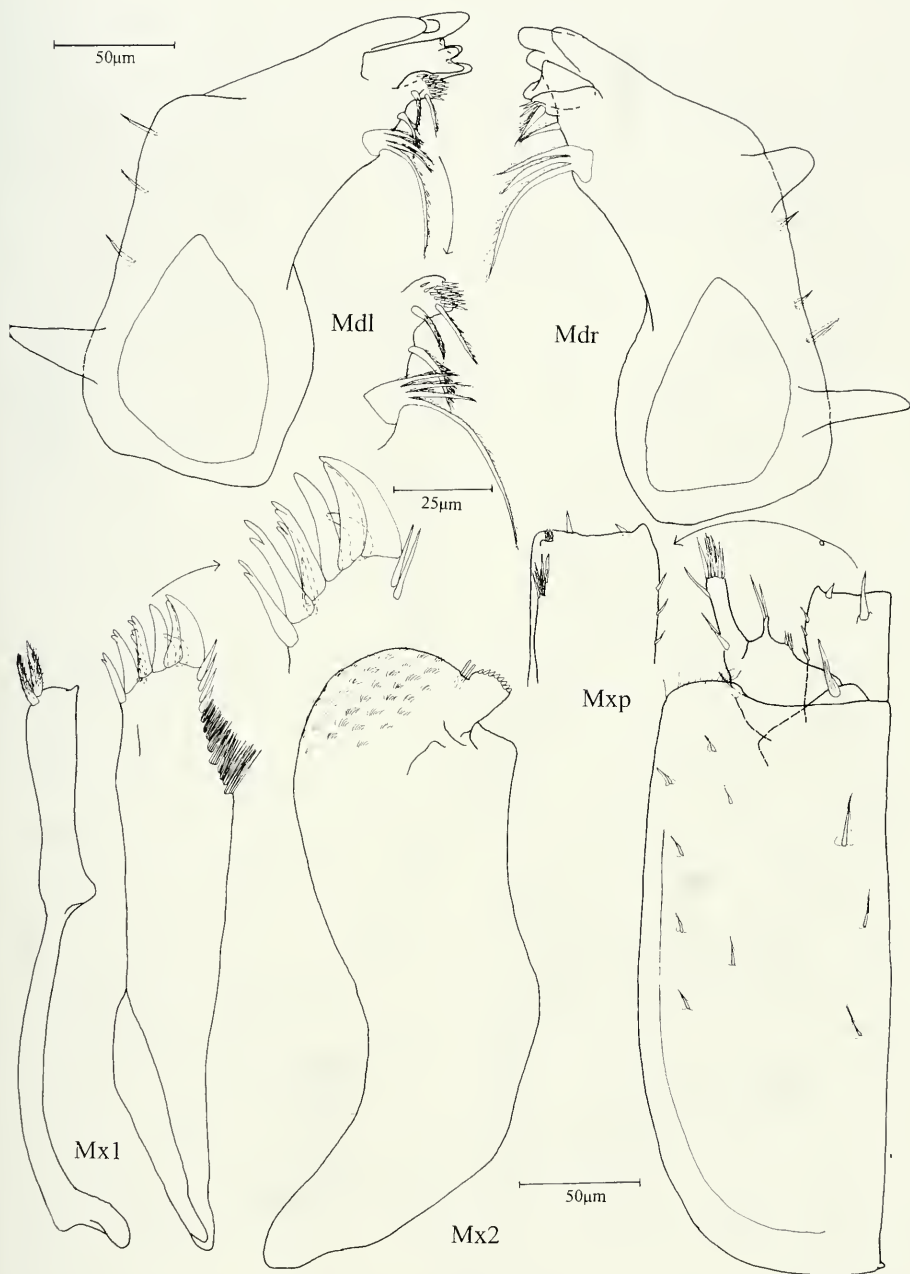

FIG. 36

*Androdeloscia poeppigi* sp. n. holotype ♂ 2.5mm. Mdl/r left and right mandible; Mxp maxilliped with detail of endite in rostral view; Mx1 maxillula with detail of apex of lateral endite in caudal and rostral view; Mx2 maxillula.

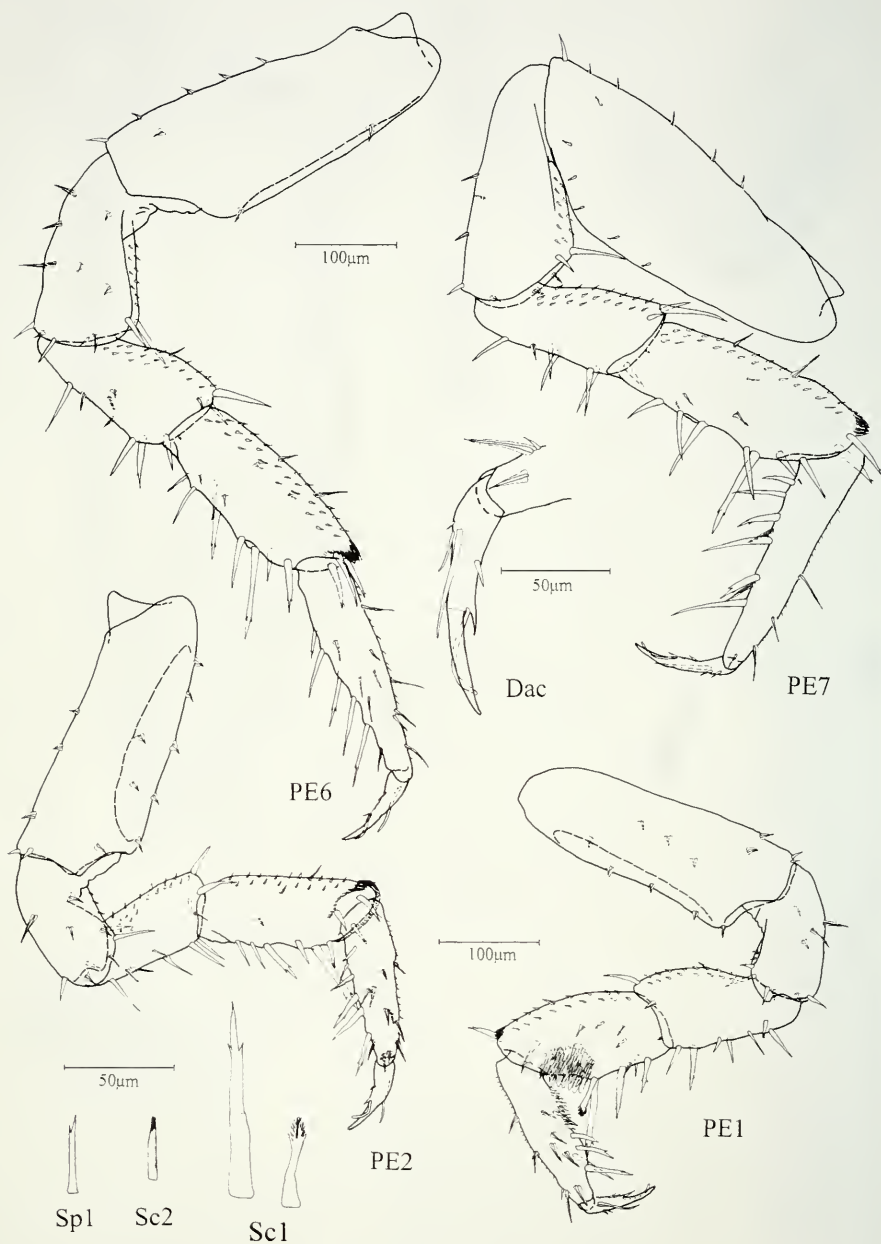

FIG. 37

*Androdeloscia poeppigi* sp. n. holotype ♂ 2.5mm. Dac dactylus 4 in rostral view; PE1-7 pereopods 1(rostral view), 2, 6, 7 (caudal view); Sc1 ornamental and longest sensory spine of carpus 1; Sc2 sensory spine of carpus 2; Sp1 distal sensory spine of propus 1.



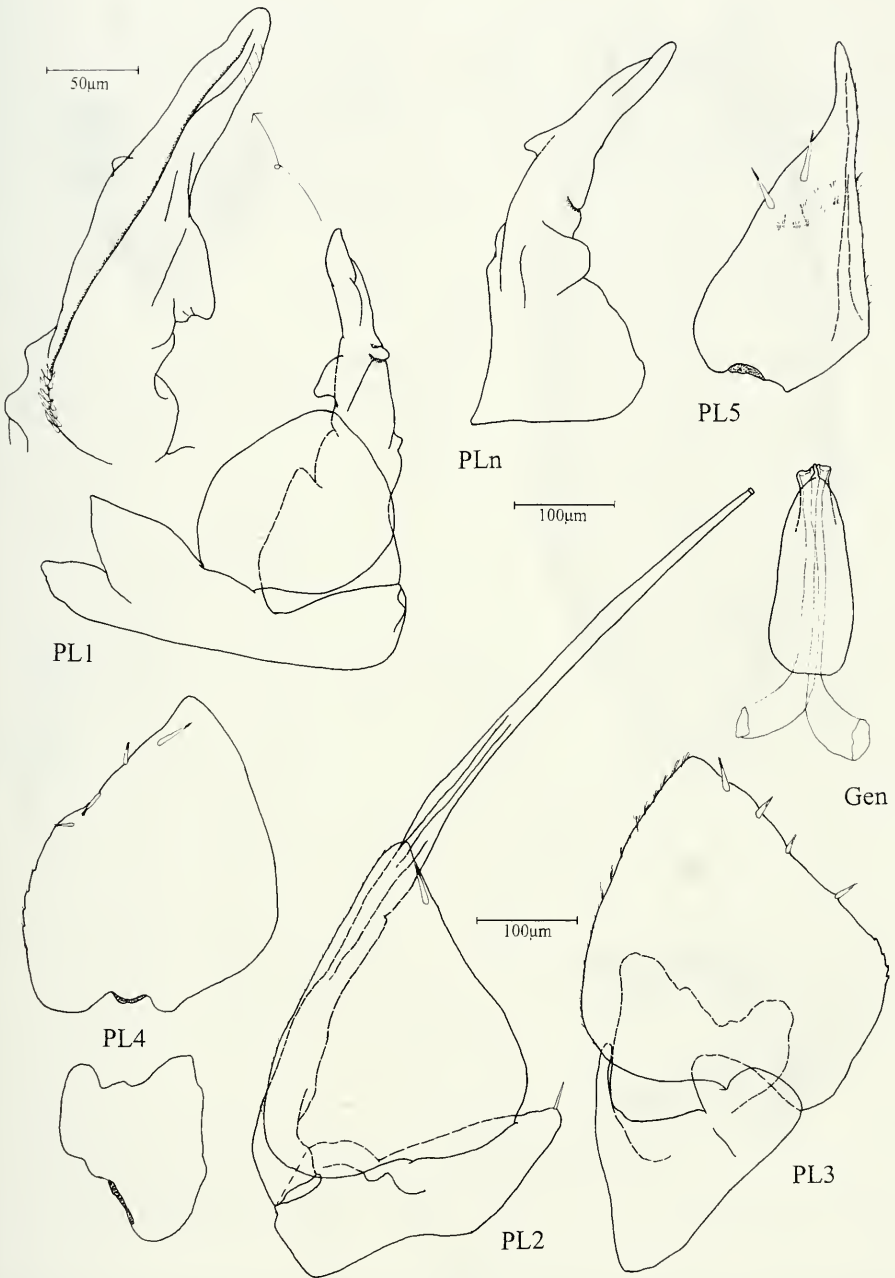

FIG. 38

*Androdeloscia poeppigi* sp. n. holotype ♂ 2.5mm. Gen genital papilla; PL1-5 pleopods 1-5, rostral view, with details of endopodite 1 in caudal and laterorostral view.

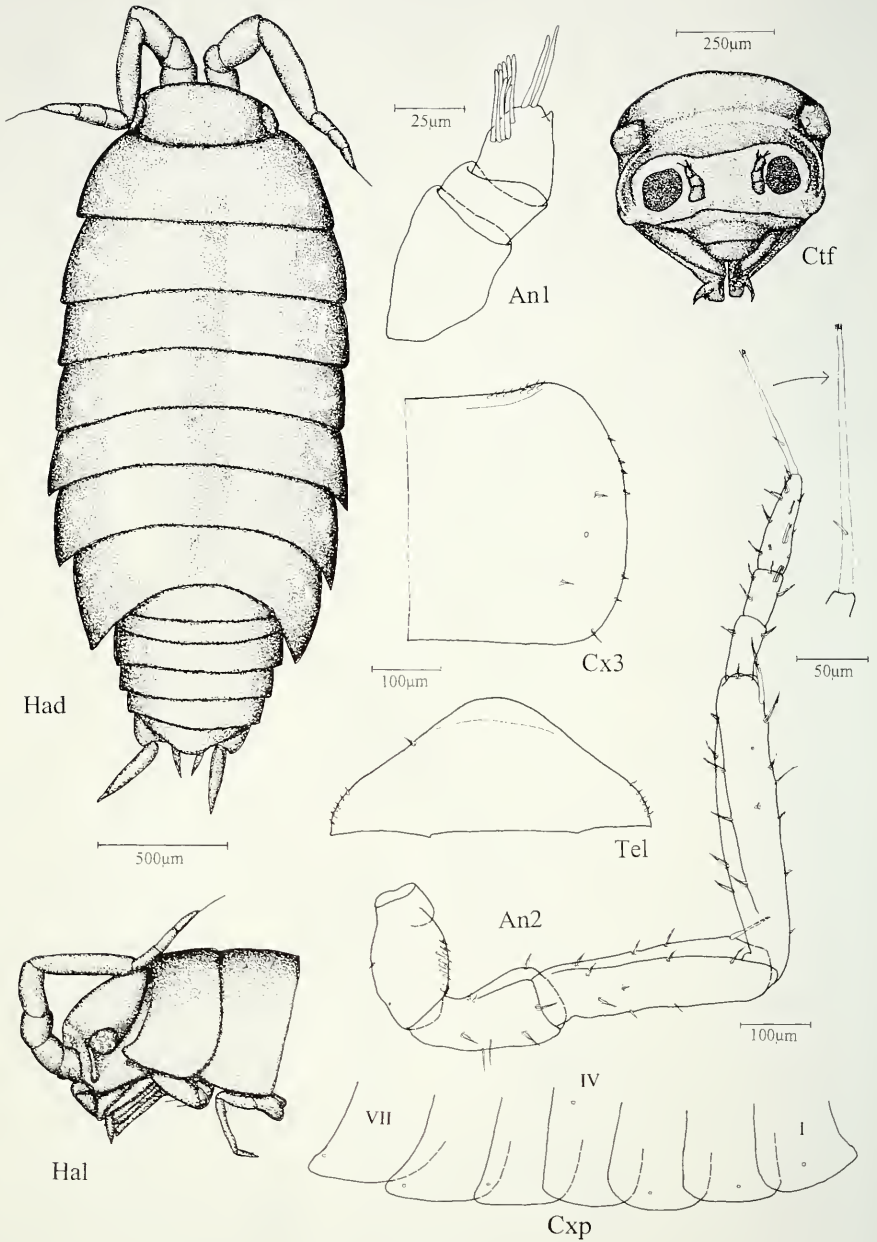

FIG. 39

*Androdeloscia malleus* sp. n. holotype ♂ 3mm. An1 antenna; An2 antenna with detail of apical organ; Ctf cephalothorax in frontal view; Cxp coxal plates with position of noduli laterales; Cx3 coxal plate 3; Had habitus in dorsal view; Hal habitus in lateral view; Tel pleotelson.

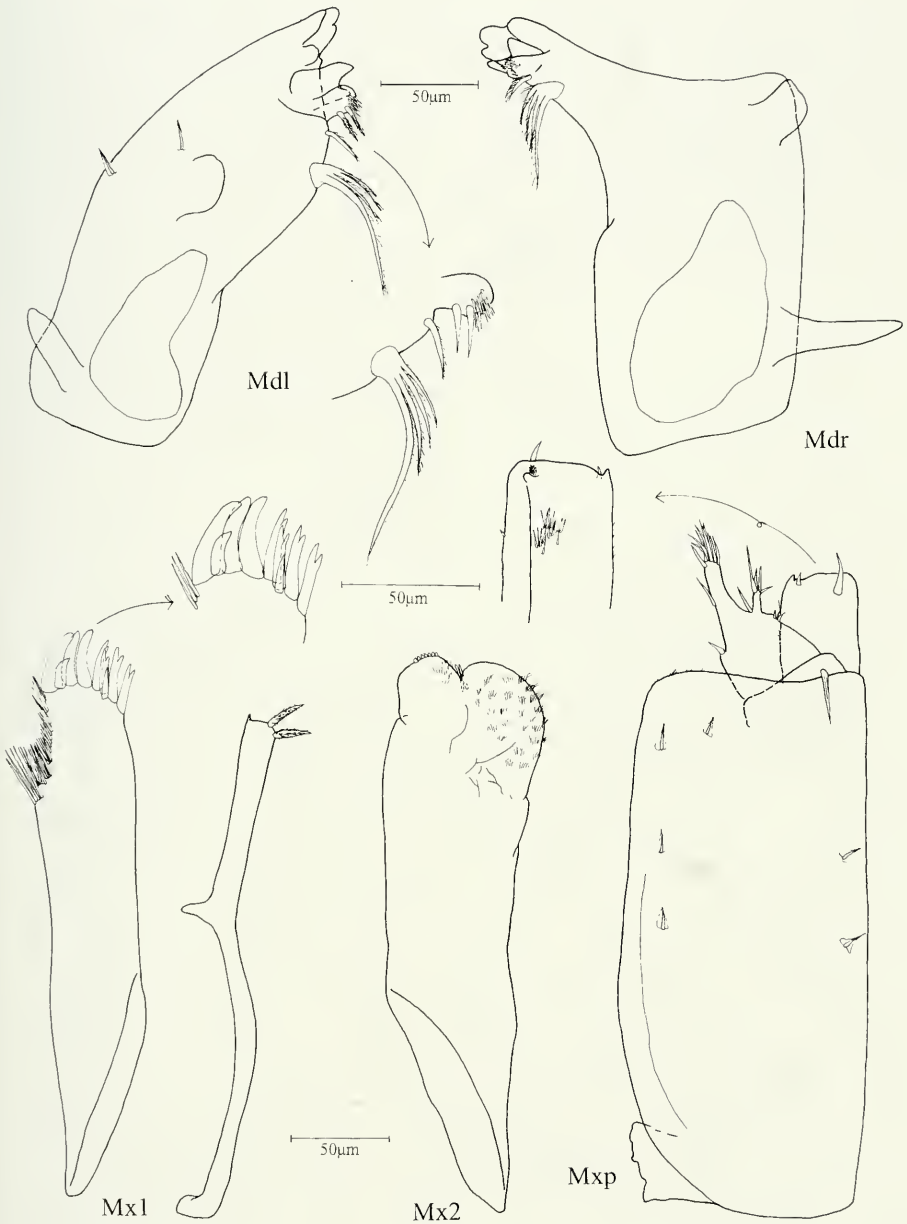

FIG. 40

*Androdeloscia malleus* sp. n. holotype ♂ 3mm. Mdl/r left and right mandible; Mxp maxilliped with detail of endite in rostral view; Mx1 maxillula with detail of apex of lateral endite; Mx2 maxilla.

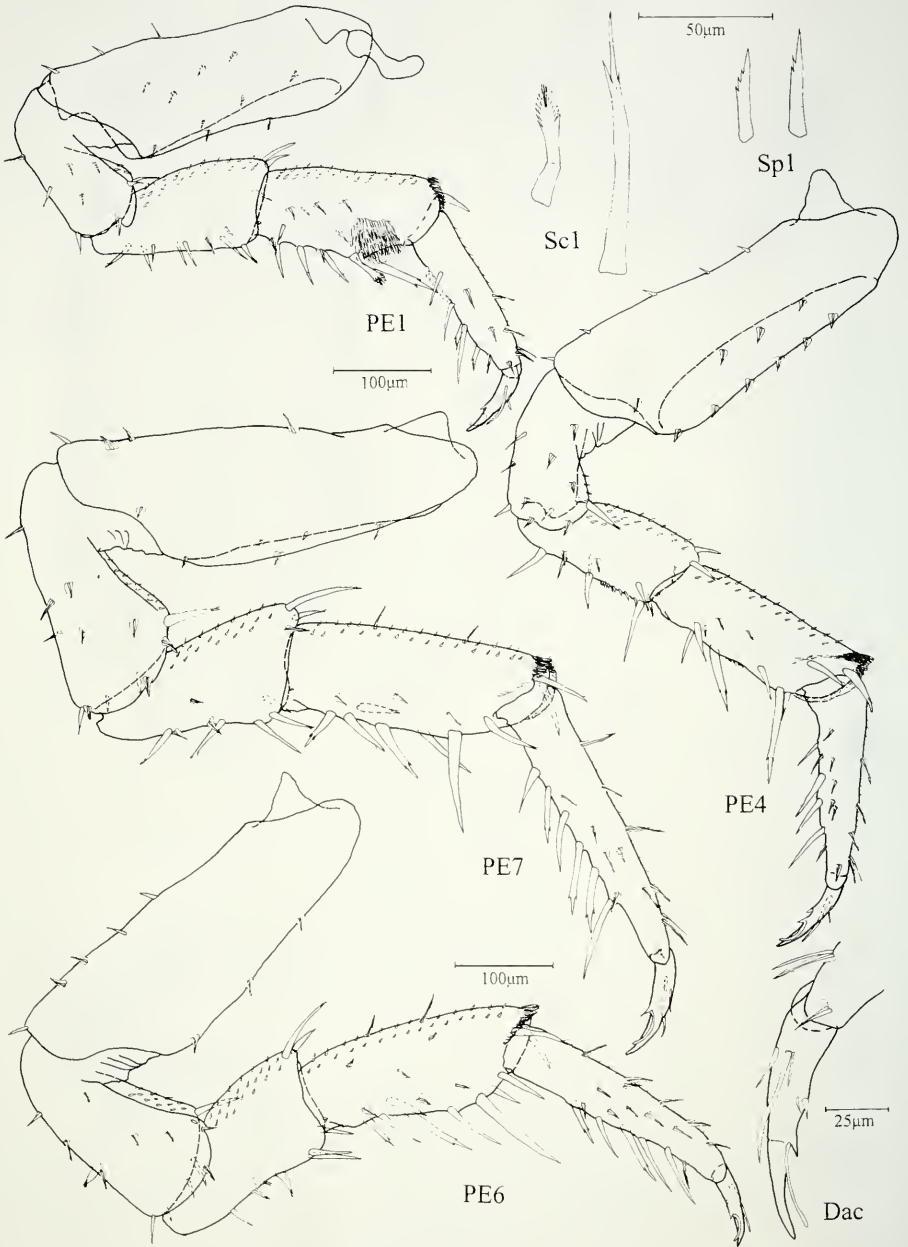

FIG. 41

*Androdeloscia malleus* sp. n. holotype ♂ 3mm. Dac dactylus 3 in rostral view; PE1-7 pereopods 1(rostral view), 4, 6, 7 (caudal view); Sc1 ornamental and longest sensory spine of carpus 1; Sp1 distal and medial sensory spine of propus 1.

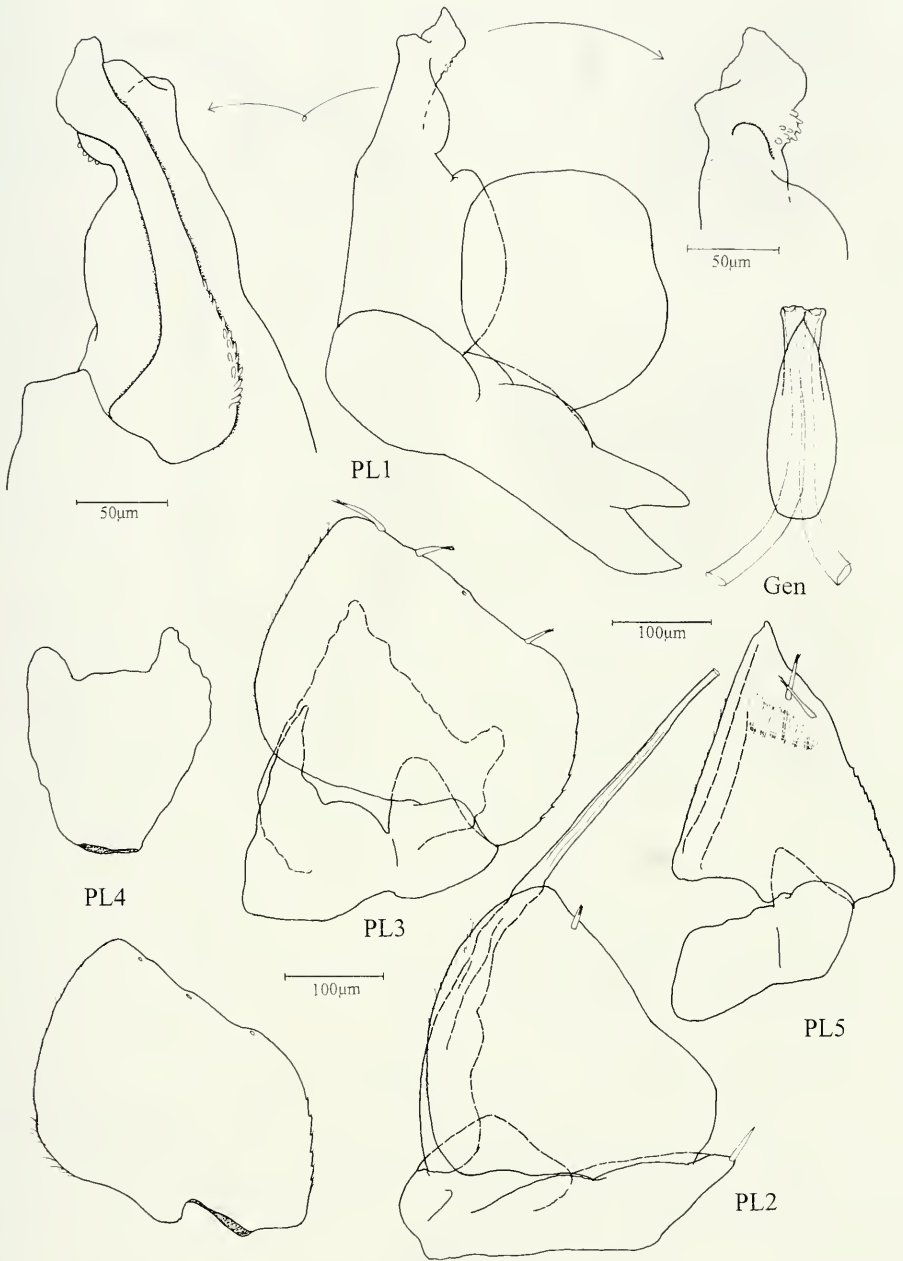

FIG. 42

*Androdeloscia malleus* sp. n. holotype ♂ 3mm. Gen genital papilla; PL1-5 pleopods 1-5, rostral view, with details of endopodite 1 in caudal and rostral view.

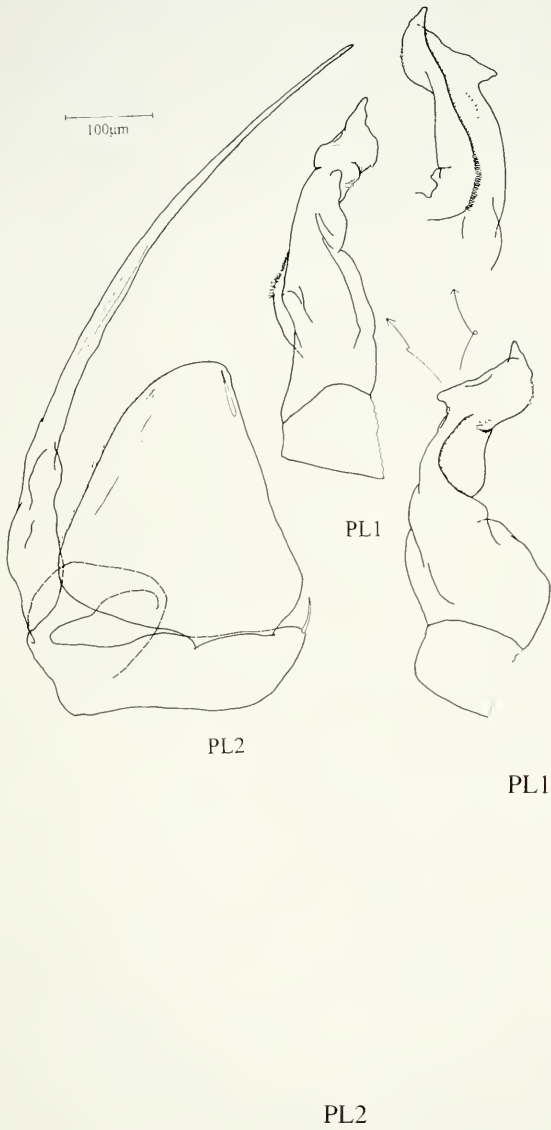

FIG. 43

*Androdeloscia malleus* sp. n. holotype ♂ 3mm. PL1-2 pleopods 1-2, rostral view, with details of endopodite 1 in caudal and mediorostral view.

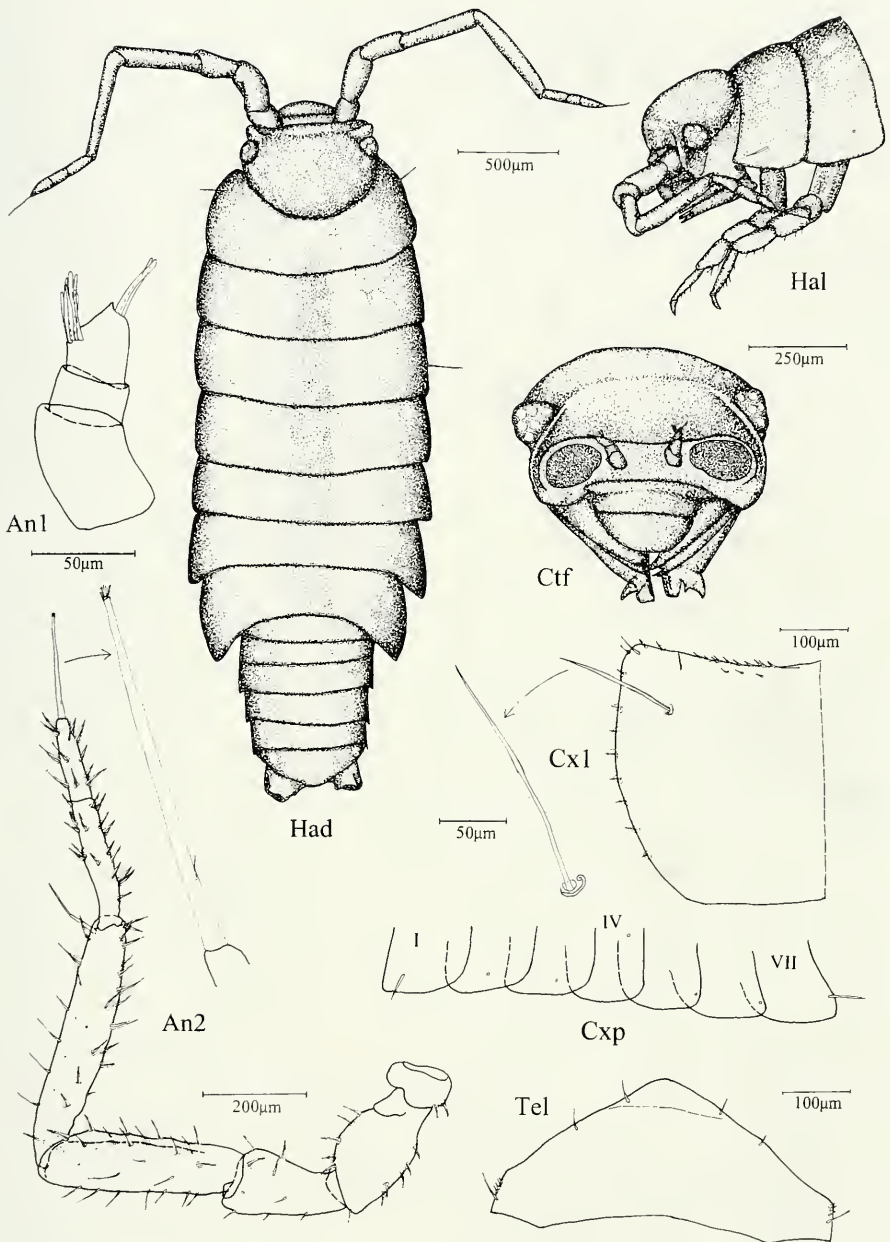

FIG. 44

*Androdeloscia opercularis* sp. n. holotype ♂ 3mm. An1 antennula; An2 antenna with detail of apical organ; Ctf cephalothorax in frontal view; Cxp coxal plates with position of noduli laterales; Cx1 coxal plate 1; Had habitus in dorsal view; Hal habitus in lateral view; Tel pleotelson.

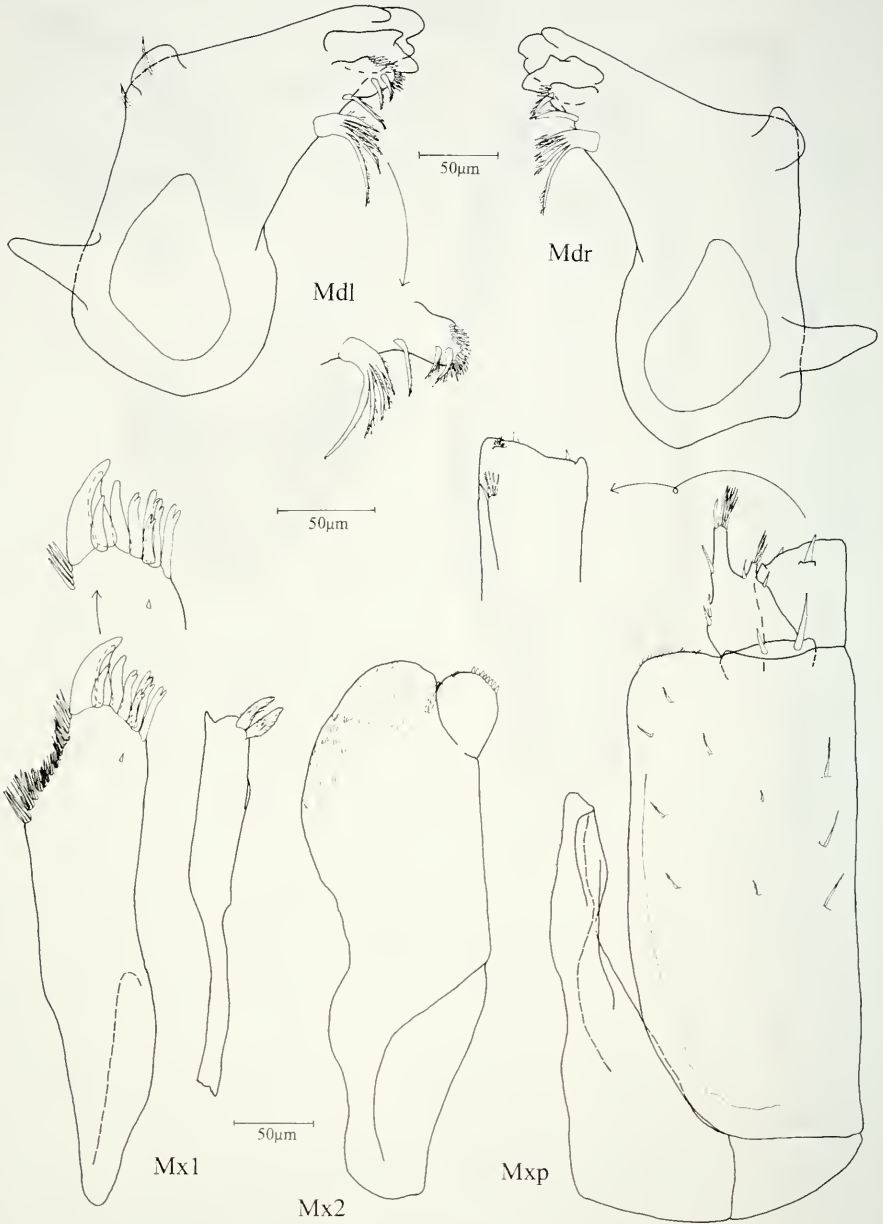

FIG. 45

*Androdeloscia opercularis* sp. n. holotype ♂ 3mm. Mdl/r left and right mandible; Mxp maxilliped with detail of endite in rostral view; Mx1 maxillula with detail of apex of lateral endite; Mx2 maxilla.



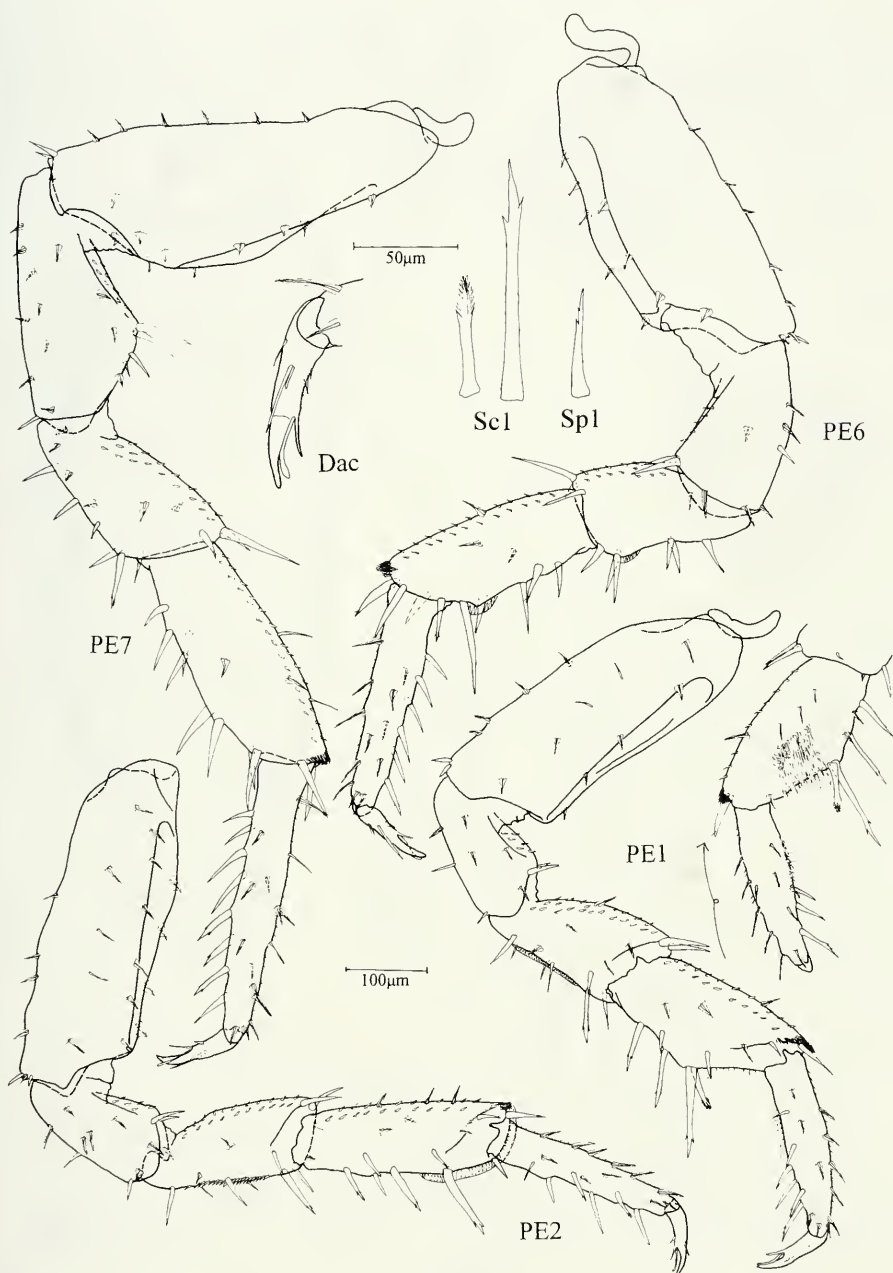

FIG. 46

*Androdeloscia opercularis* sp. n. holotype ♂ 3mm. Dac dactylus 3 in rostral view; PE1-7 pereopods 1, 2, 6, 7 (caudal view), detail of carpus 1 (rostral view); Sc1 ornamental and longest sensory spine of carpus 1; Spl distal and medial sensory spine of propus 1.

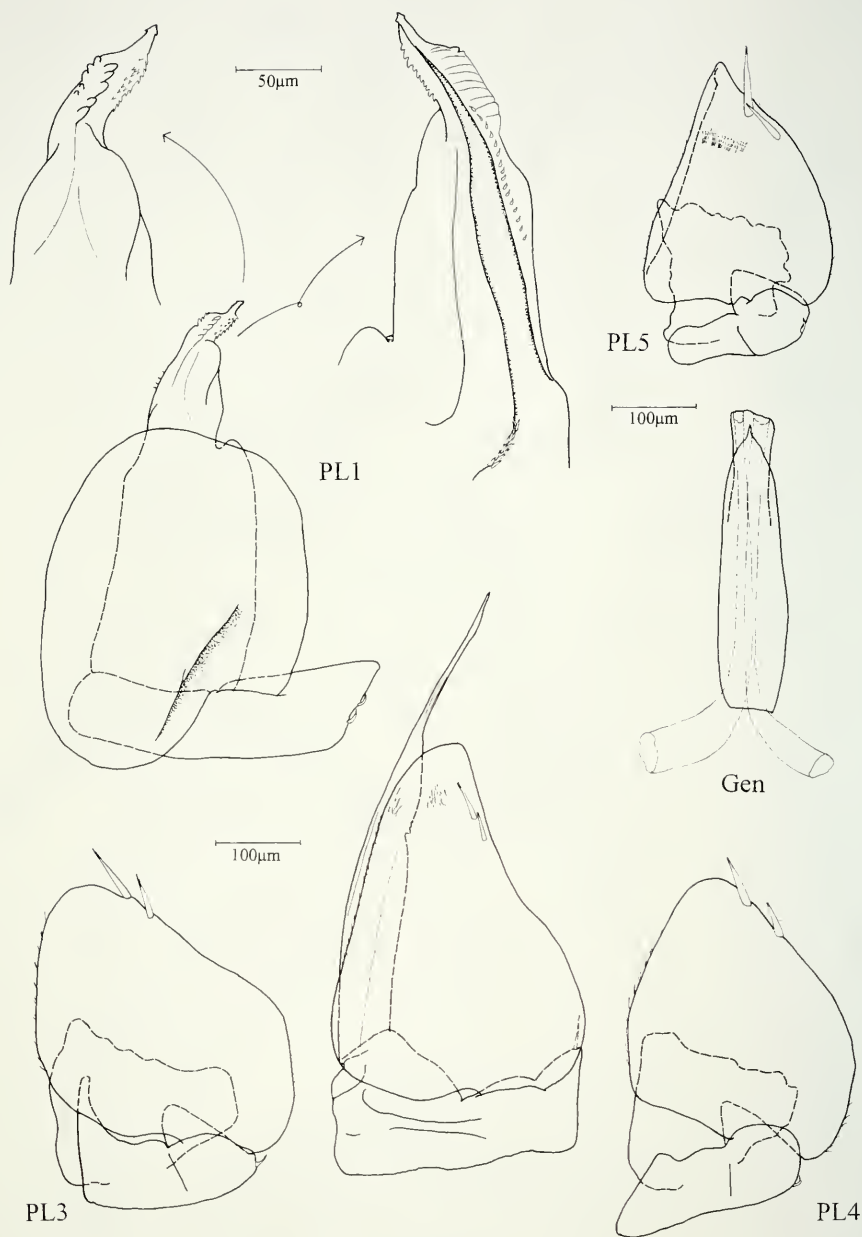

FIG. 47

*Androdeloscia opercularis* sp. n. holotype ♂ 3mm. Gen genital papilla; PL1-5 pleopods 1-5, rostral view, with details of endopodite 1 in caudal and rostral view.

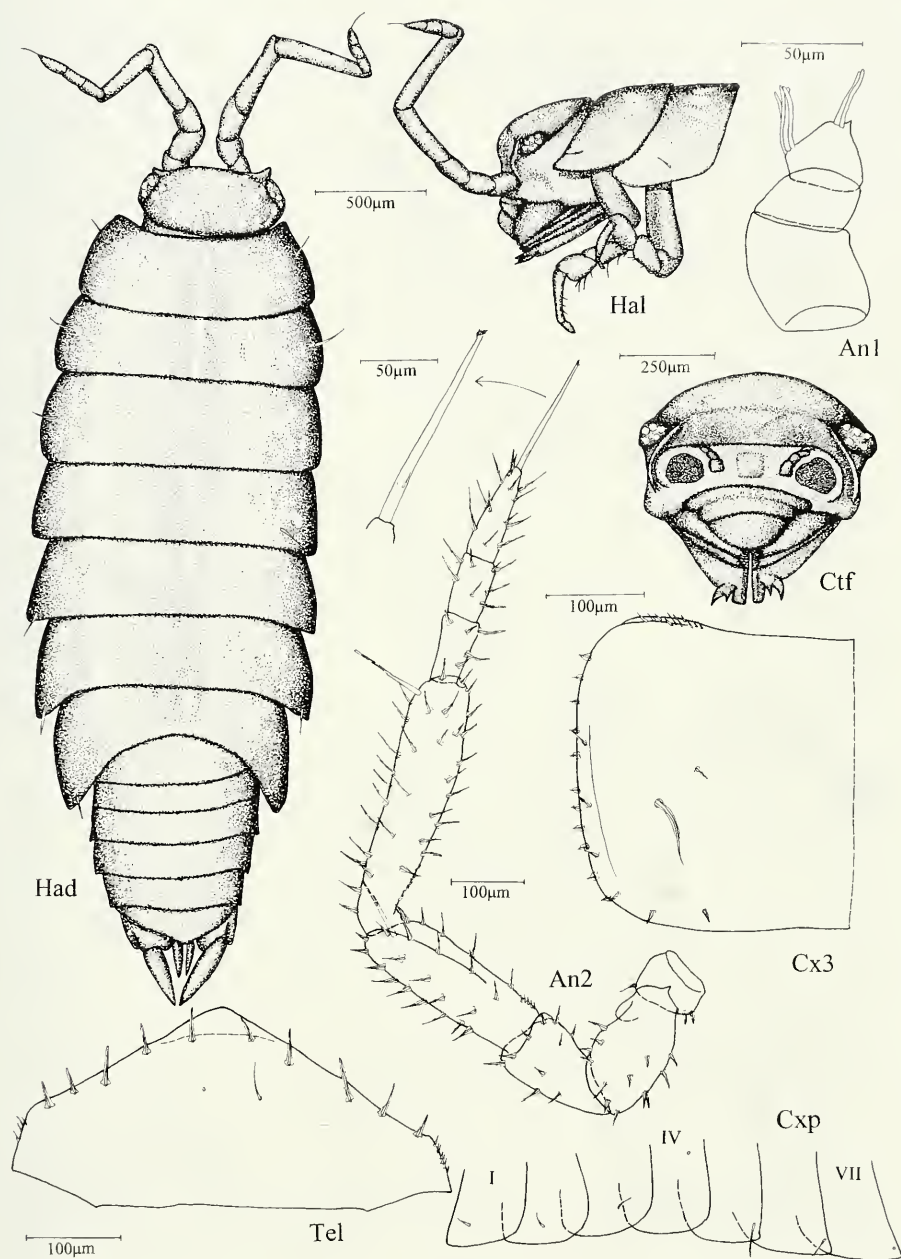

FIG. 48

*Androdeloscia silvaica* (Lemos de Castro & Souza, 1986) ♂ 3.5mm. An1 antennula; An2 antenna with detail of apical organ; Ctf cephalothorax in frontal view; Cxp coxal plates with position of noduli laterales; Cx3 coxal plate 3; Had habitus in dorsal view; Hal habitus in lateral view; Tel pleotelson.

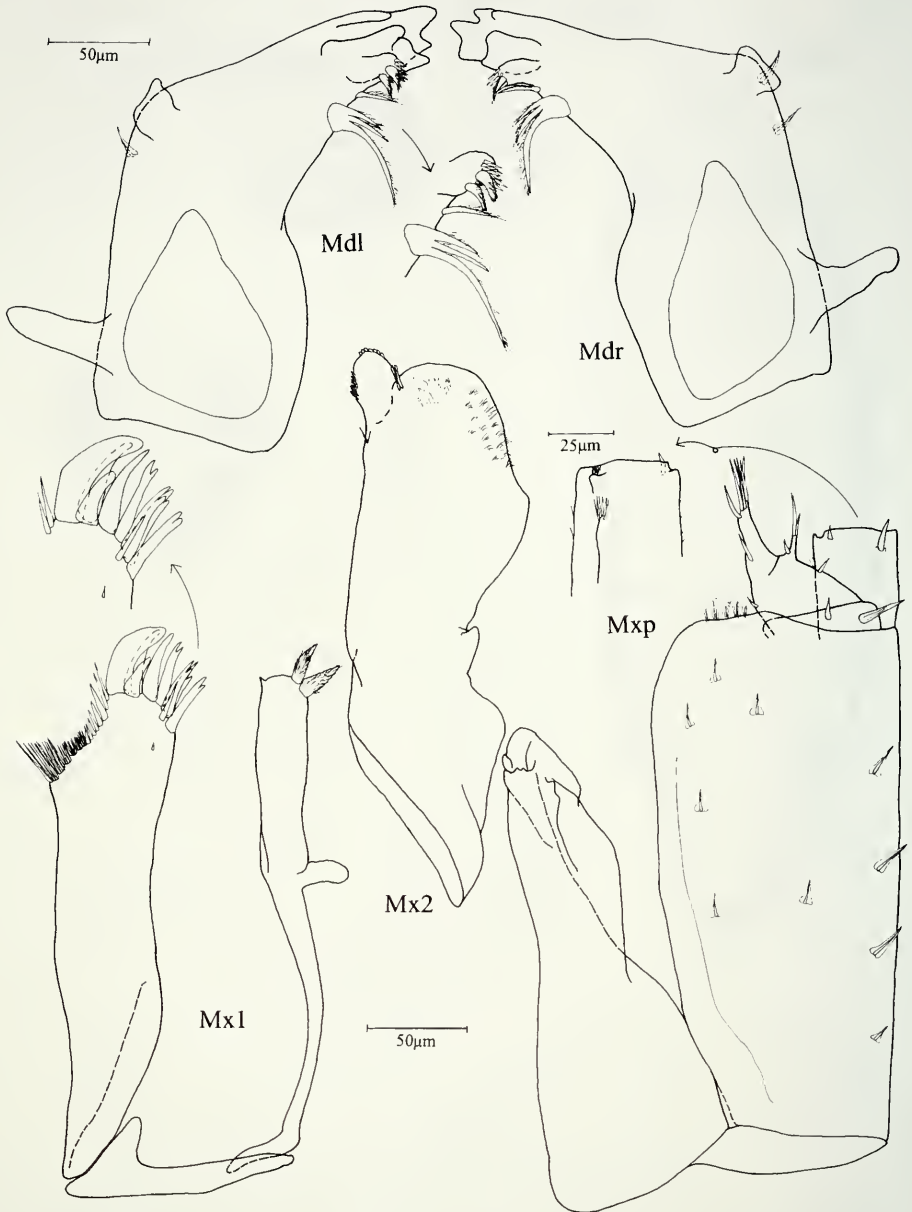

FIG. 49

*Androdeloscia silvatica* (Lemos de Castro & Souza, 1986) ♂ 3.5mm. Mdl/r left and right mandible; Mxp maxilliped with detail of endite in rostral view; Mx1 maxillula with detail of apex of lateral endite; Mx2 maxilla.

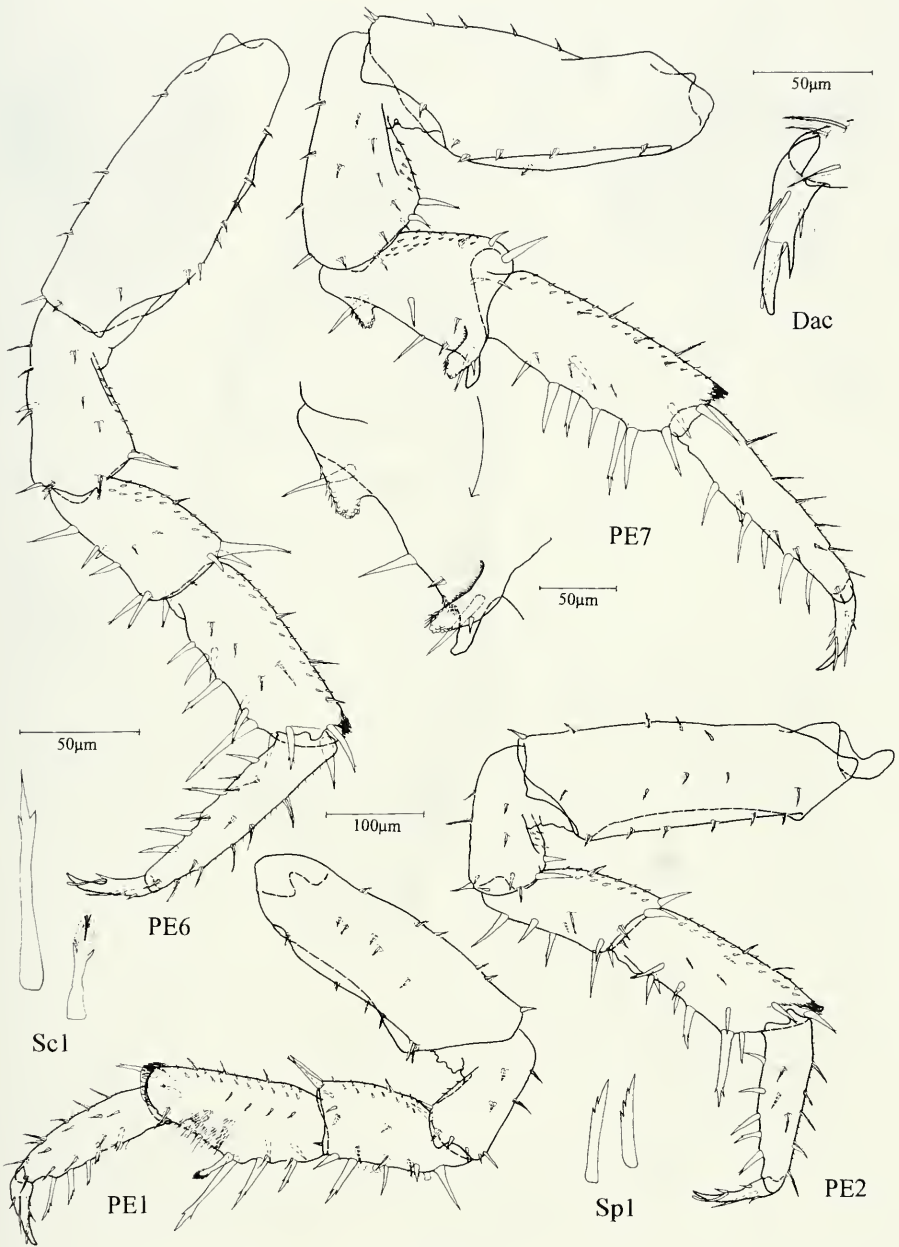

FIG. 50

*Androdeloscia silvatica* (Lemos de Castro & Souza, 1986) ♂ 3.5mm. Dac dactylus 1 in rostral view; PE1-7 pereopods 1 (rostral view), 2, 6, 7 (caudal view), with detail of merus 7; Sc1 ornamental and longest sensory spine of carpus 1; Sp1 distal and medial sensory spine of propus 1.

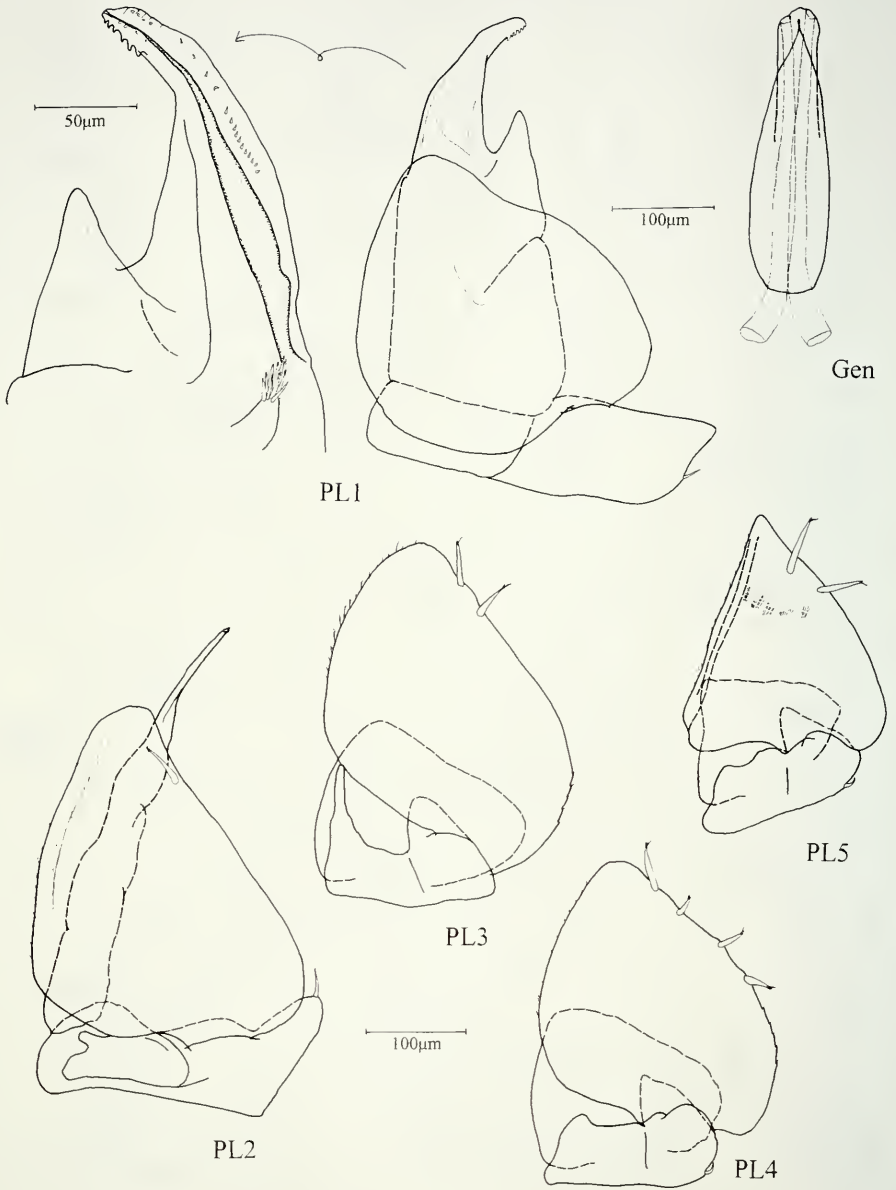

FIG. 51

*Androdeloscia silvatica* (Lemos de Castro & Souza, 1986) ♂ 3.5mm. Gen genital papilla; PL1-5 pleopods 1-5, rostral view, with detail of endopodite 1 in caudal view.

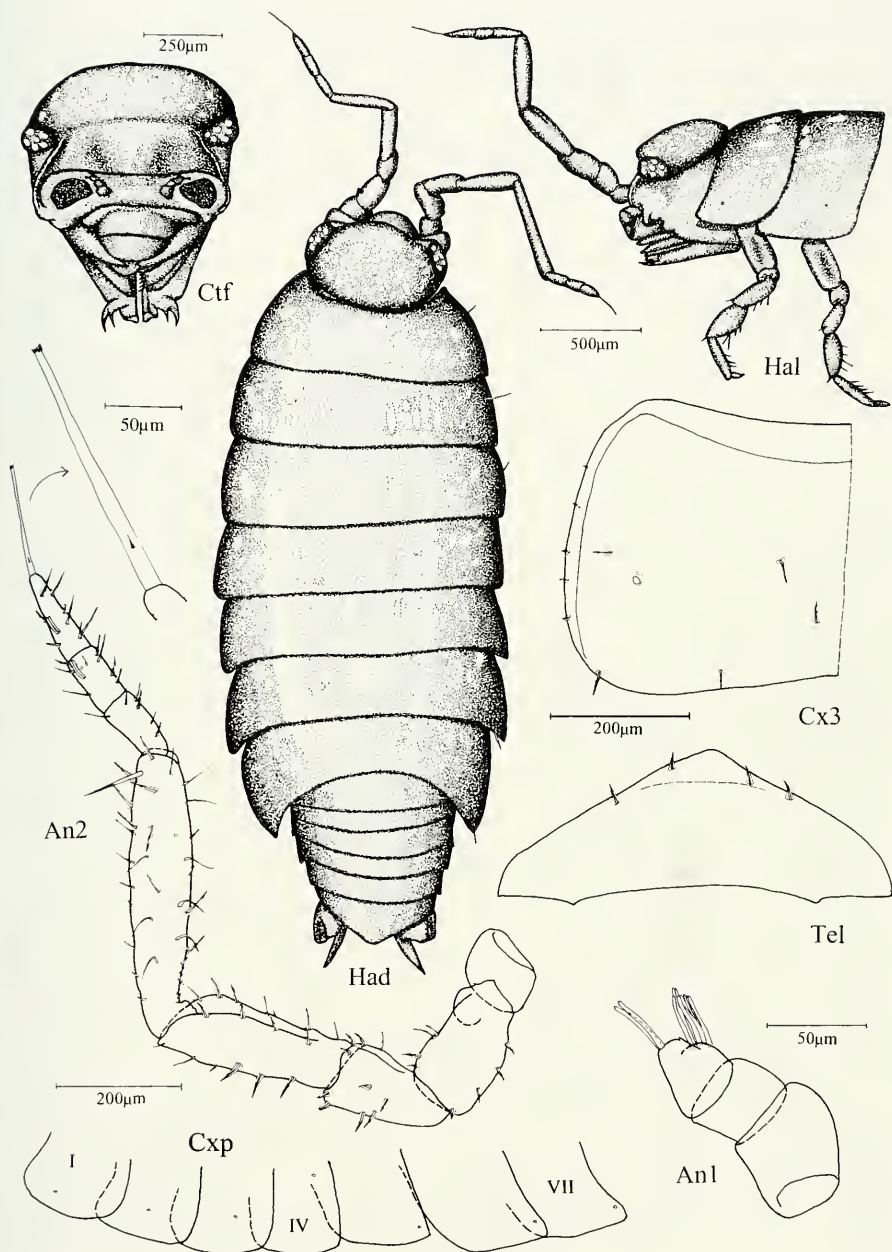

FIG. 52

*Androdeloscia pseudosilvatica* sp. n. holotype ♂ 3mm. An1 antennula; An2 antenna with detail of apical organ; Ctf cephalothorax in frontal view; Cxp coxal plates with position of noduli laterales; Cx3 coxal plate 3; Had habitus in dorsal view; Hal habitus in lateral view; Tel pleotelson.

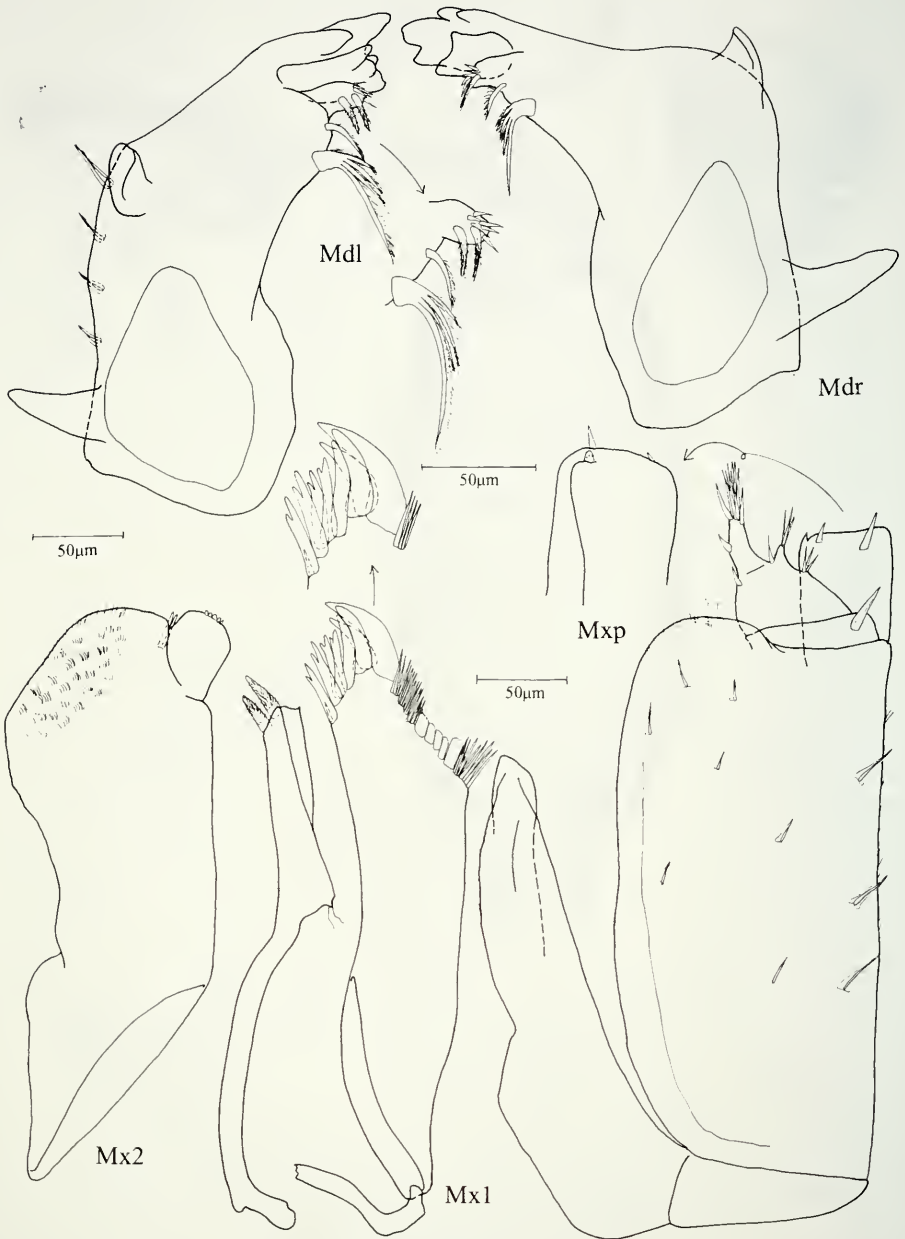

FIG. 53

*Androdeloscia pseudosilvatica* sp. n. holotype ♂ 3mm. Mdl/r left and right mandible; Mxp maxilliped with detail of endite in rostral view; Mx1 maxillula with detail of apex of lateral endite; Mx2 maxilla.



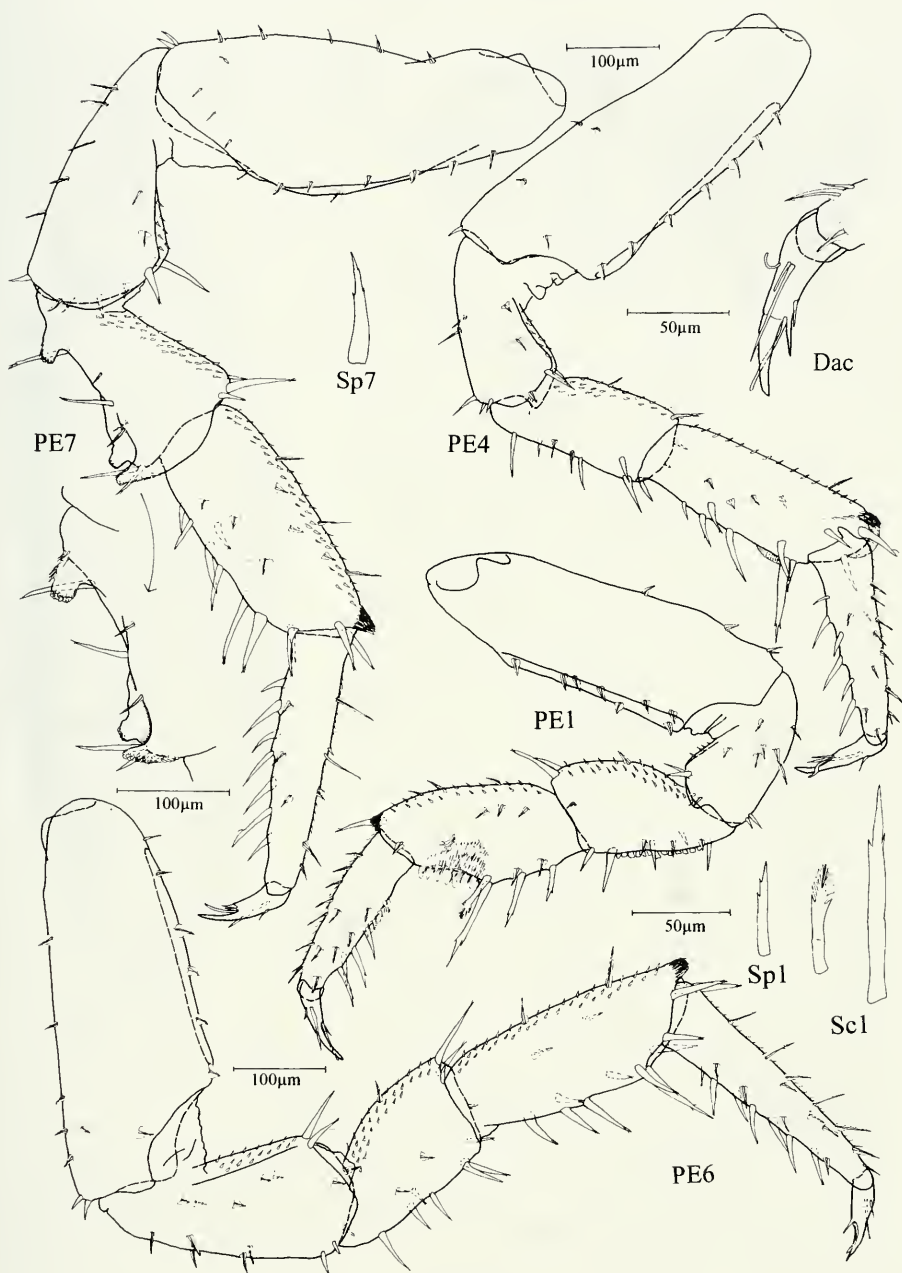

FIG. 54

*Androdeloscia pseudosilvatica* sp. n. holotype ♂ 3mm. Dac dactylus 3 in rostral view; PE1-7 pereopods 1 (rostral view), 4, 6, 7 (caudal view), with detail of merus 7; Sc1 ornamental and longest sensory spine of carpus 1; Sp1 distal and medial sensory spine of propus 1; Sp7 sensory spine of propus 7.

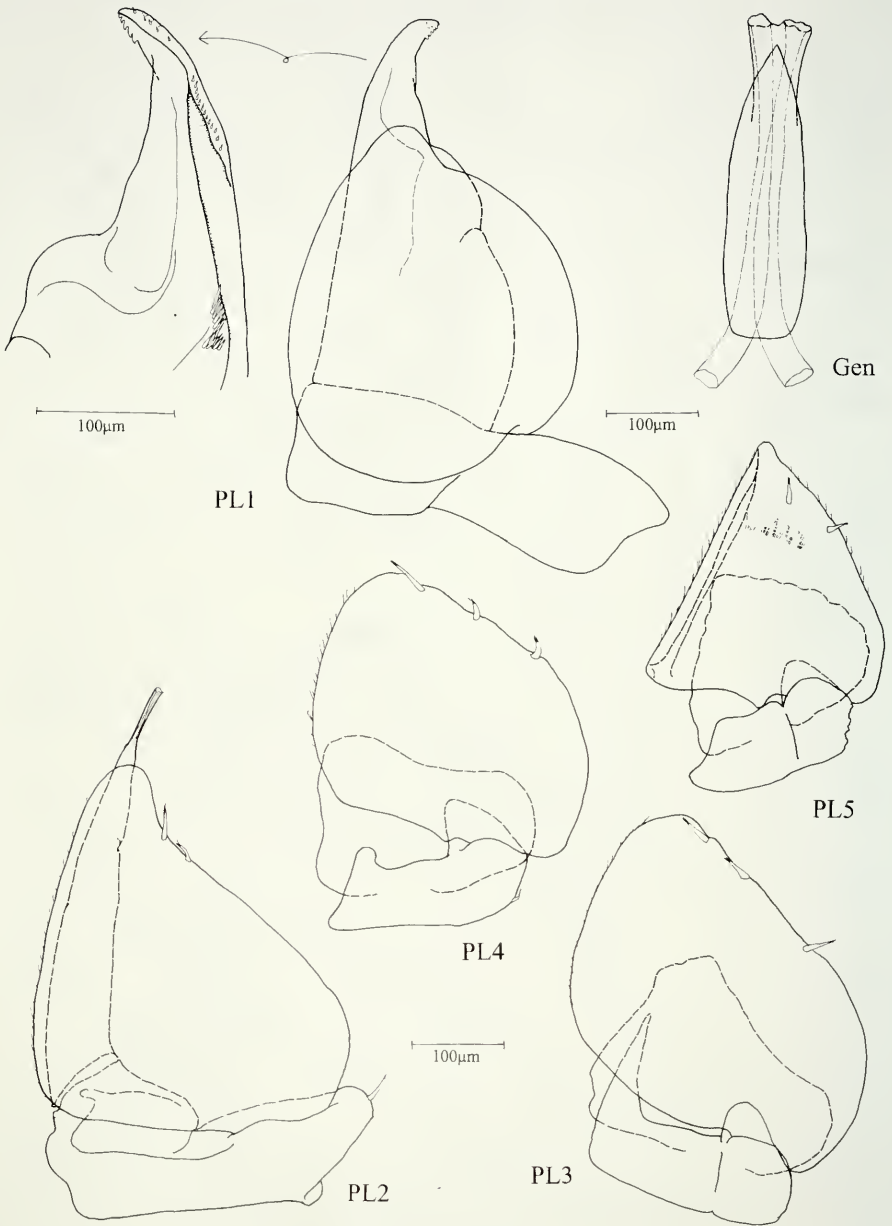

FIG. 55

*Androdeloscia pseudosilvatica* sp. n. holotype ♂ 3mm. Gen genital papilla; PL1-5 pleopods 1-5, rostral view, with detail of endopodite 1 in caudal view.

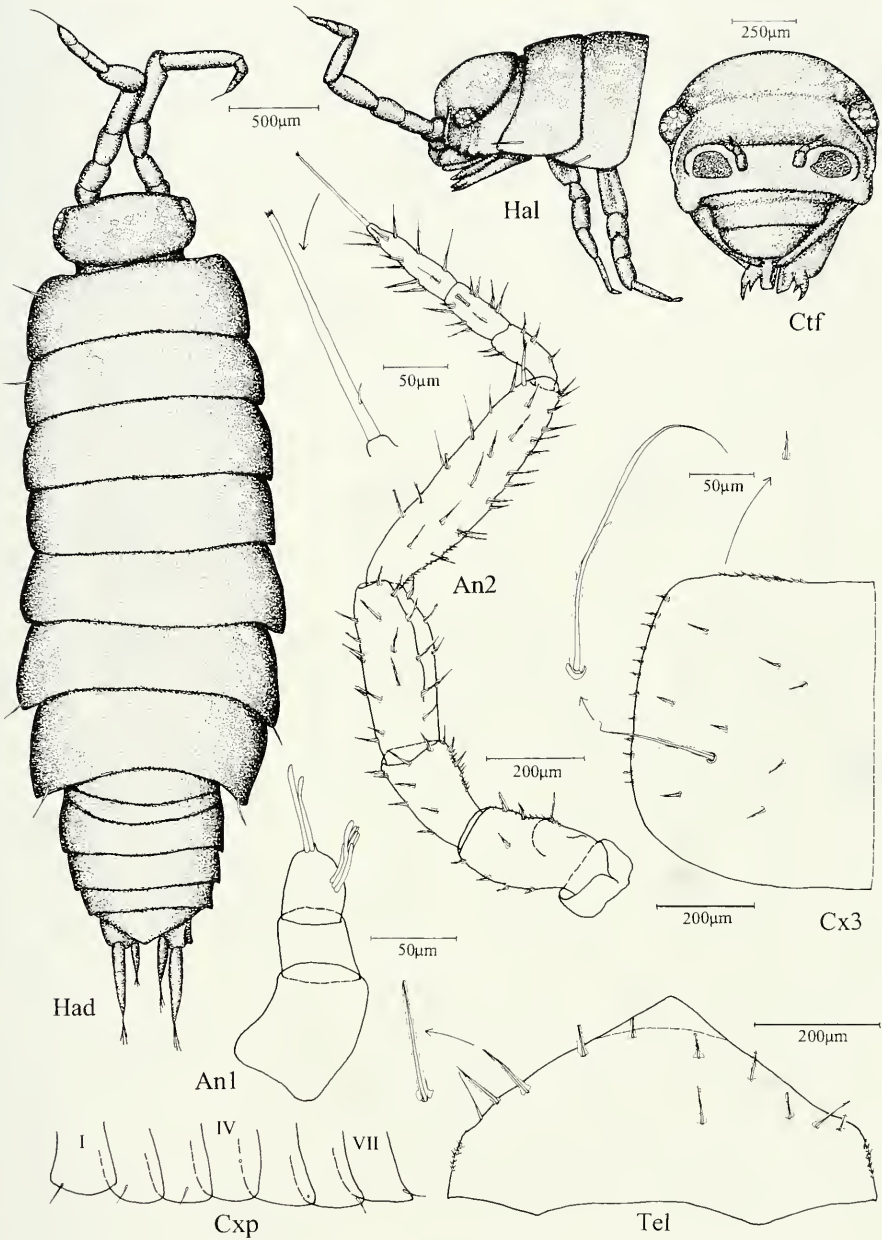

FIG. 56

*Androdeloscia dalensi* sp. n. holotype ♂ 3.5mm. An1 antennula; An2 antenna with detail of apical organ; Ctf cephalothorax in frontal view; Cxp coxal plates with position of noduli laterales; Cx3 coxal plate 3; Had habitus in dorsal view; Hal habitus in lateral view; Tel pleotelson.

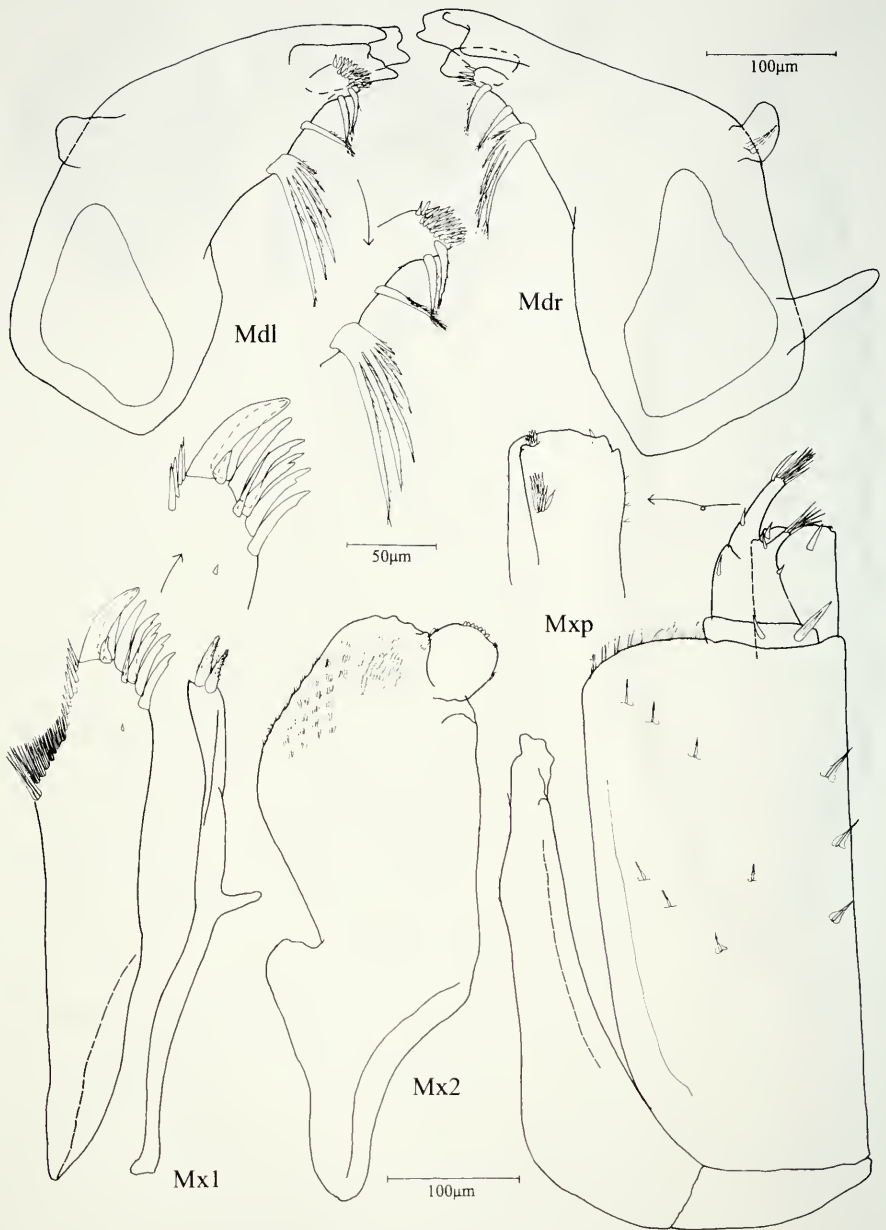

FIG. 57

*Androdeloscia dalensi* sp. n. holotype ♂ 3.5mm. Mdl/r left and right mandible; Mxp maxilliped with detail of endite in rostral view; Mx1 maxillula with detail of apex of lateral endite; Mx2 maxilla.

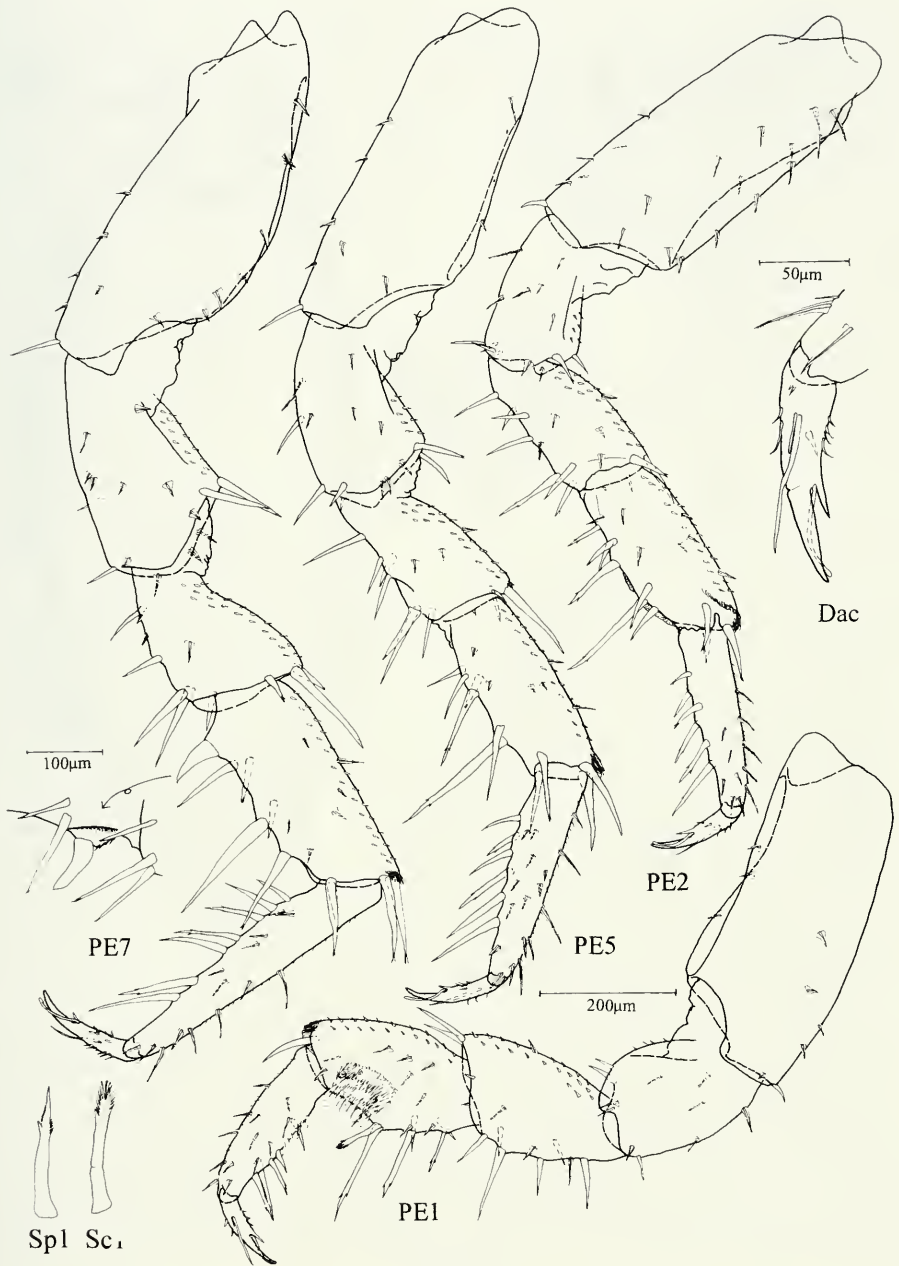

FIG. 58

*Androdeloscia dalensi* sp. n. holotype ♂ 3.5mm. Dac dactylus 1 in rostral view; PE1-7 pereopods 1 (rostral view), 2, 5, 7 (caudal view), with detail of carpus 7 in rostral view; Sc1 ornamental sensory spine of carpus 1; Spl distal sensory spine of propus 1.

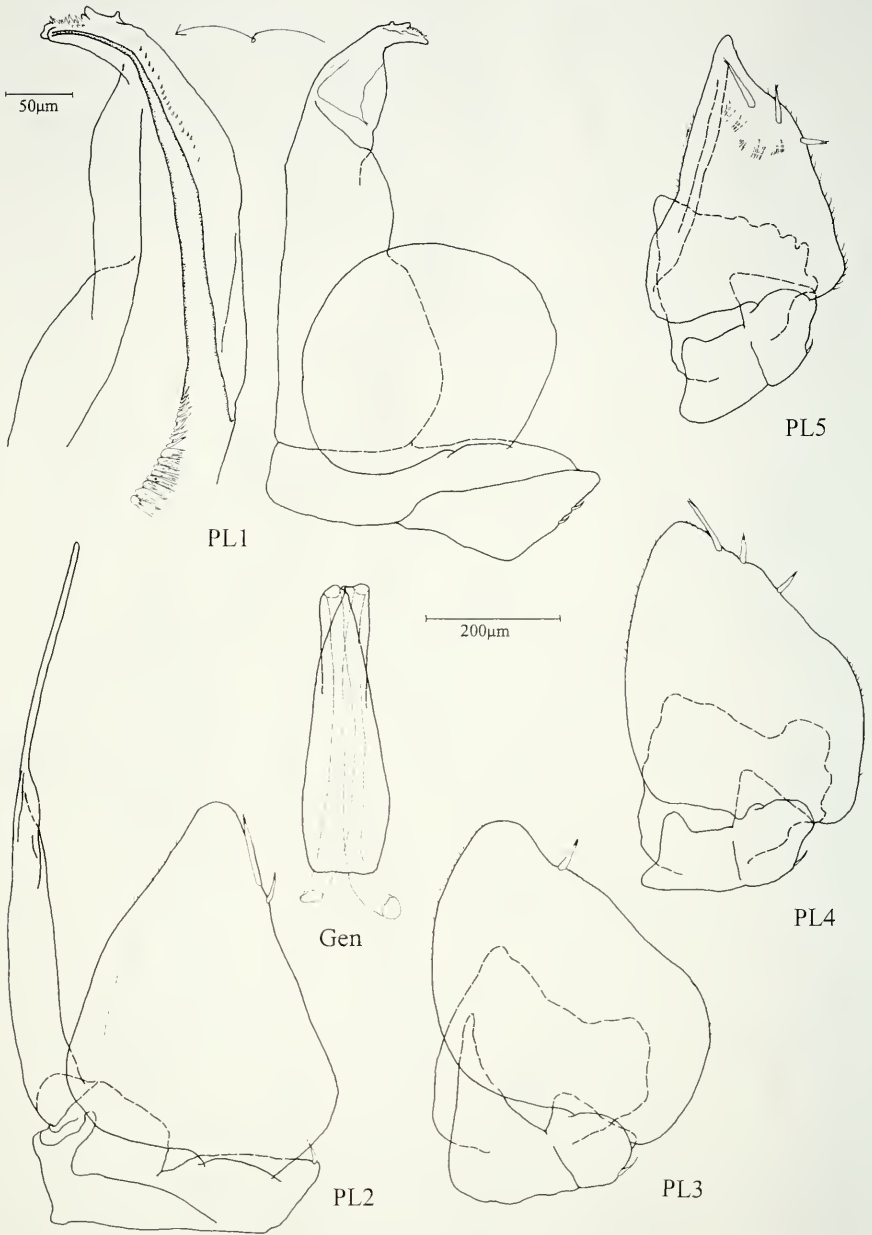

FIG. 59

*Androdeloscia dalensi* sp. n. holotype ♂ 3.5mm. Gen genital papilla; PL1-5 pleopods 1-5, rostral view, with detail of endopodite 1 in caudal view.

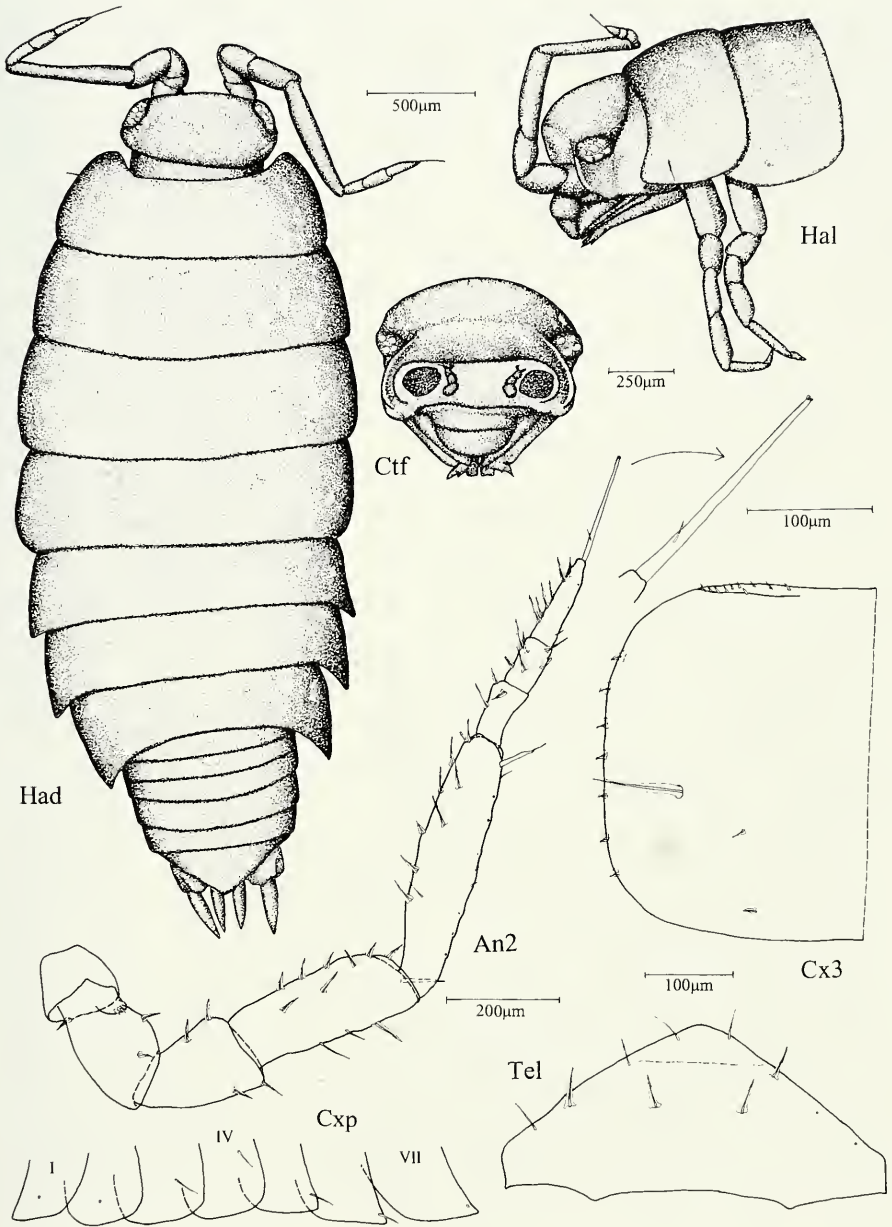

FIG. 60

*Androdeloscia digitata* sp. n. holotype ♂ 3mm. An2 antenna with detail of apical organ; Ctf cephalothorax in frontal view; Cxp coxal plates with position of noduli laterales; Cx3 coxal plate 3; Had habitus in dorsal view; Hal habitus in lateral view; Tel pleotelson.

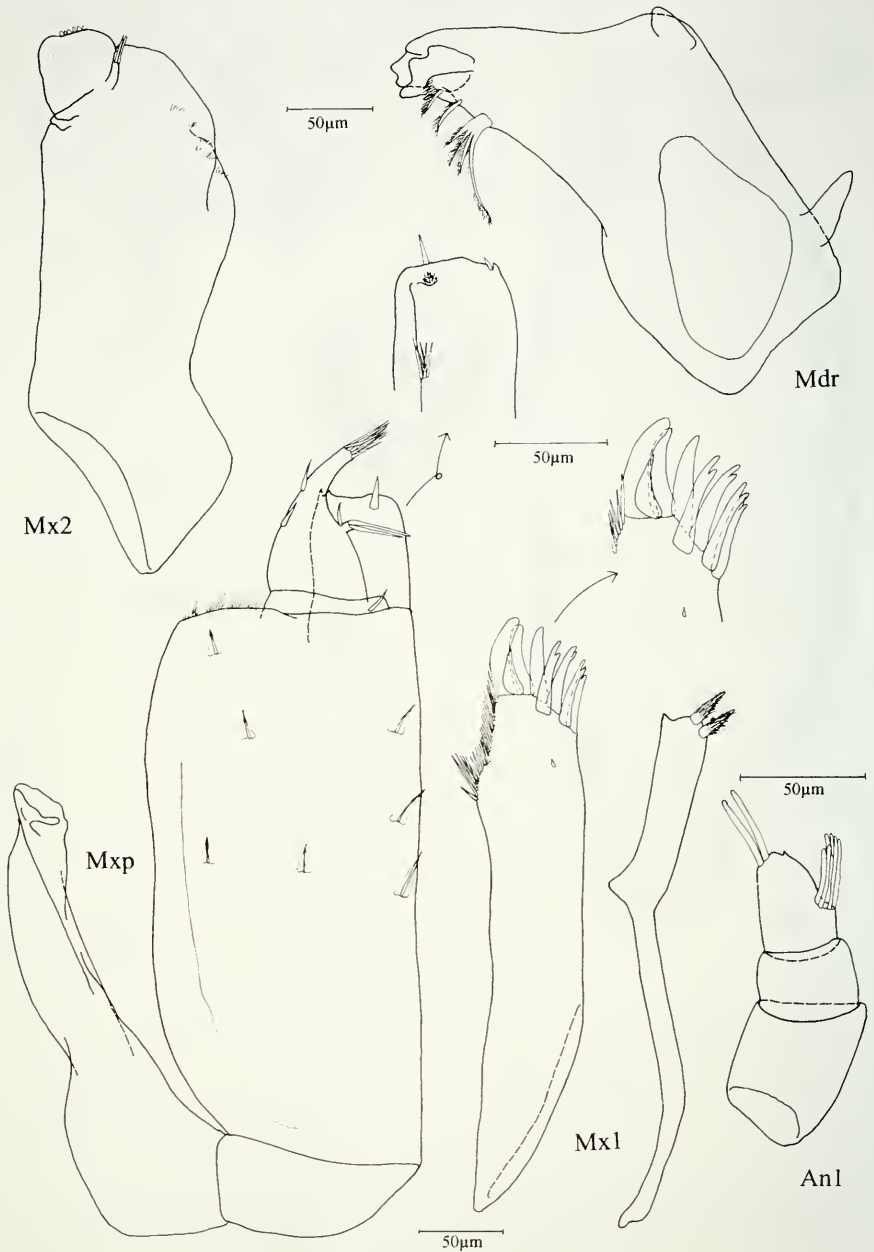

FIG. 61

*Androdeloscia digitata* sp. n. holotype ♂ 3mm. An1 antennula; Mdr right mandible; Mxp maxilliped with detail of endite in rostral view; Mx1 maxillula with detail of apex of lateral endite; Mx2 maxilla.



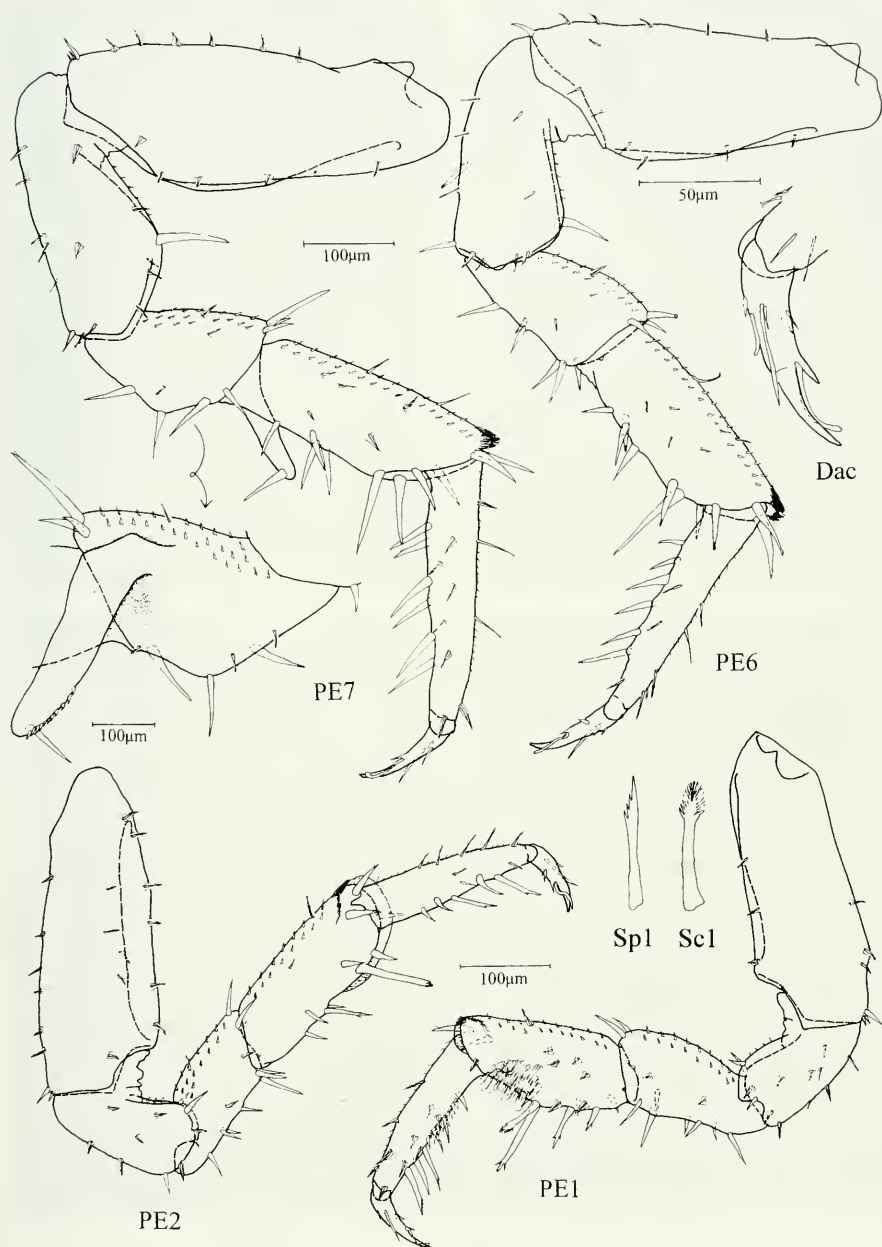

FIG. 62

*Androdeloscia digitata* sp. n. holotype ♂ 3mm. Dac dactylus 1 in rostral view; PE1-7 pereopods 1 (rostral view), 2, 6, 7 (caudal view), with detail of merus 7 in rostral view; Sc1 ornamental sensory spine of carpus 1; Sp1 distal sensory spine of propus 1.

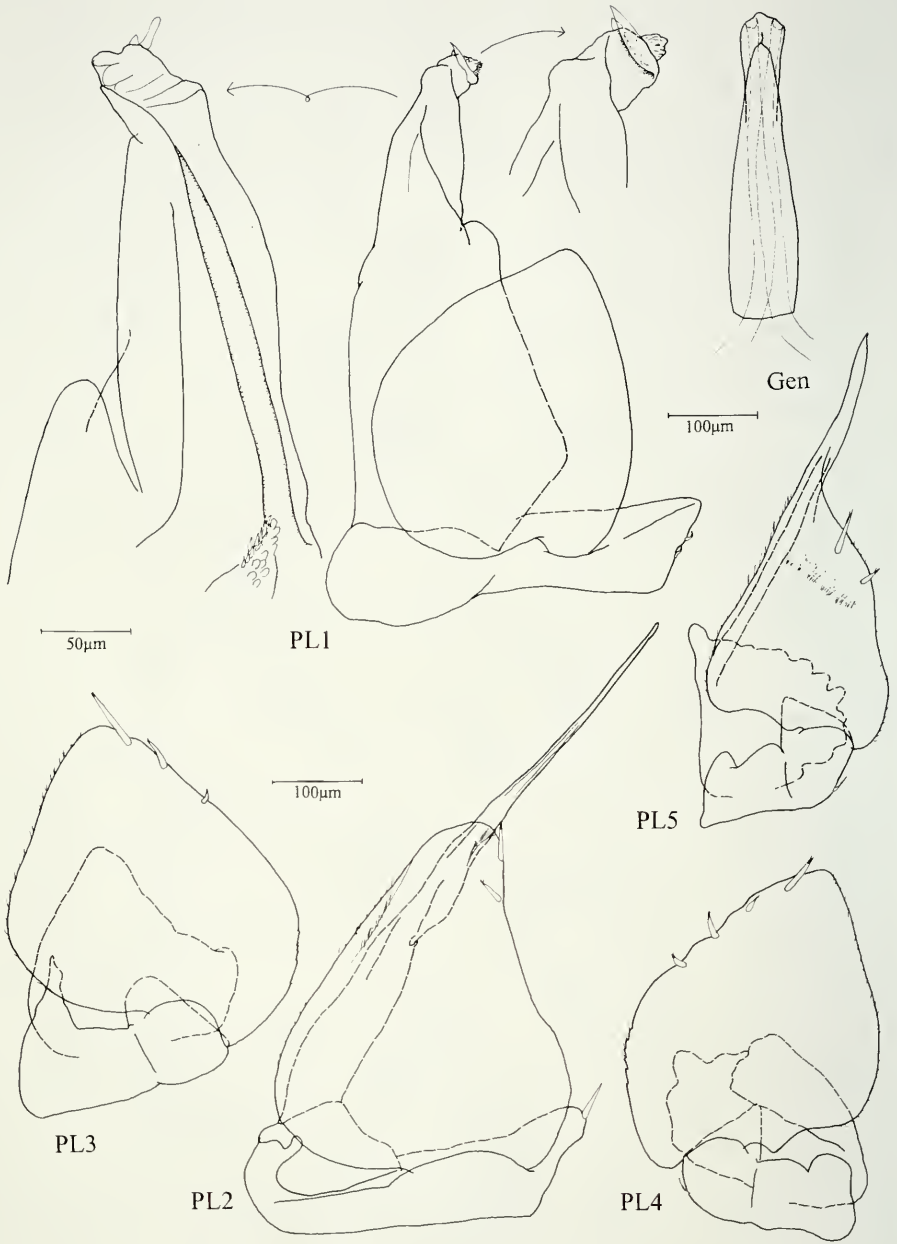

FIG. 63

*Androdeloscia digitata* sp. n. holotype ♂ 3mm. Gen genital papilla; PL1-5 pleopods 1-5, rostral view, with detail of endopodite 1 in caudal and rostral view.

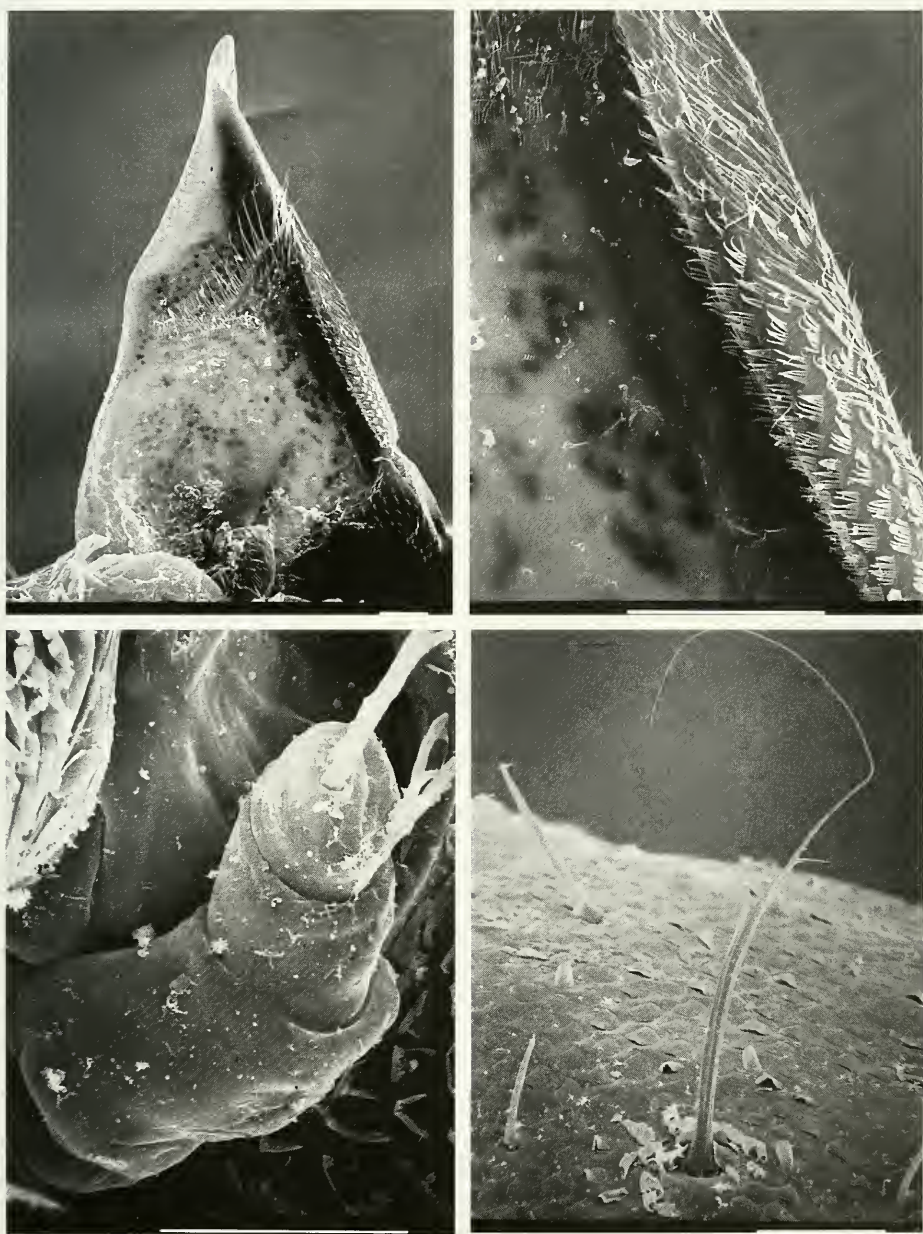

FIG. 64

*Androdeloscia ferrarai* sp. n. Above left: male pleopod 5 exopodite from caudal; above right: guide slot of pleopod 5 with pectinate scales. - *Androdeloscia merolobata* sp. n. Below left: antennula, below right: nodulus lateralis of coxal plate 3; scale bars: 50  $\mu$ m.

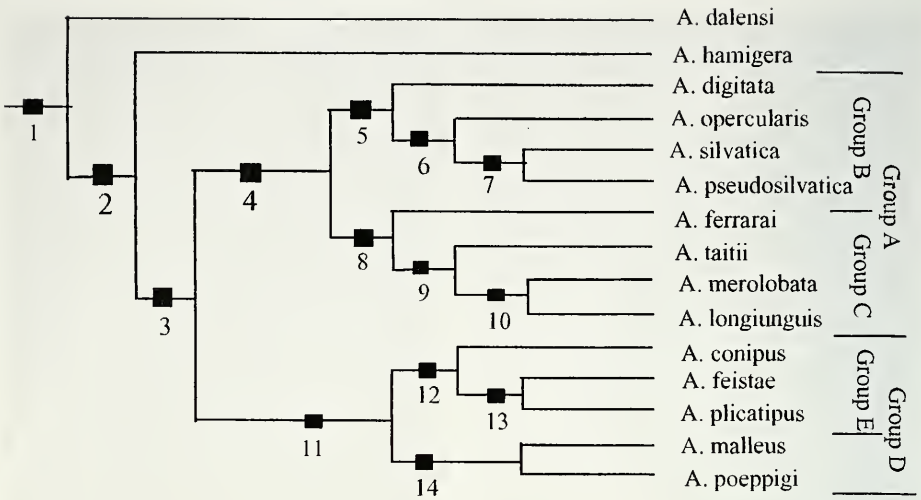

FIG. 65

Phylogenetic relationships within the genus *Androdeloscia* gen. n., explanation of apomorphic characters see text.

## REFERENCES

- ERHARD, F. 1997. Das pleonale Skelet-Muskel-System von *Titanethes albus* und weiterer Taxa der Oniscidea mit Schlußfolgerungen zur Phylogenie der Landasseln. *Stuttgarter Beiträge zur Naturkunde, Serie B (Biologie)* 550: 1-70.
- LEISTIKOW, A. 1998. Redescriptions of terrestrial Isopoda from Chile and Peru (Crustacea: Isopoda: Oniscidea). *Spixiana* 21(3): 215-225.
- LEMONS DE CASTRO, A. 1984. Uma nova espécie de *Prosekia* de uma floresta inundável na Amazonia Central. *Amazoniana* 8: 441-445.
- LEMONS DE CASTRO, A. & SOUZA, L. A. 1986. Três espécies novas de isópodes terrestres do gênero *Prosekia* Vandel da Amazonia Brasileira. *Revista Brasileira de Zoologia* 46: 429-438.
- LIMA, I. M. B. 1997. Uma nova espécie de *Prosekia* Vandel, 1968 da Amazonia Brasileira (Crustacea: Isopoda: Philosciidae). *Amazoniana* 14: 101-104.
- SCHMALFUSS, H. 1980. A revision of the neotropical genus *Ischioscia* Verhoeff, with description of four new species. *Studies on Neotropical Fauna and Environment* 15: 125-139.
- SCHMALFUSS, H. 1990. Die Landisopoden Griechenlands. 11. Beitrag: Gattung *Chaetophiloscia*. *Revue suisse de Zoologie* 97: 169-193.
- SIMPSON, B. B. & HAFFER, J. 1978. Speciation patterns in the Amazonian forest biota. *Annual Review of Ecology and Systematics* 9: 497-518.
- STURM, H. 1994. Diskontinuierliche Gene und Evolution. *Zeitschrift für zoologische Systematik und Evolutionsforschung* 32: 241-263.
- VANDEL, A. 1952. Étude des isopodes terrestres récoltés au Vénézuéla par le Dr. G. Marcuzzi. *Memorias del Museo civico di Storia Naturale in Verona* 3: 59-203.
- VANDEL, A. 1968. Isopodes terrestres. In: LELEUP N. and J. (eds). *Mission zoologique belge aux Iles de Galapagos et Ecuador* 84: 35-168.
- VANDEL, A. 1972. Les isopodes terrestres de la Colombie. *Studies on Neotropical Fauna and Environment* 7: 147-172.
- VERHOEFF, K. W. 1908. Neue Isopoden-Gattungen. *Zoologischer Anzeiger* 33: 520-525.

***Sphaeropsocopsis myrtleae* sp. n., a blind subterranean psocid from St Helena (Psocoptera: Sphaeropsocidae)**

Charles LIENHARD<sup>1</sup> & N. Philip ASHMOLE<sup>2</sup>

<sup>1</sup> Muséum d'histoire naturelle, c. p. 6434, CH-1211 Genève 6, Switzerland.

<sup>2</sup> University of Edinburgh, Division of Biological Sciences, West Mains Road, Edinburgh EH9 3JT, U. K.

***Sphaeropsocopsis myrtleae* sp. n., a blind subterranean psocid from St Helena (Psocoptera: Sphaeropsocidae).** - The new species is described and illustrated, based on a female captured by a modified pitfall trap ("boot trap") in a lava tube on the mid-Atlantic island of St Helena. The species is adapted to subterranean life in being depigmented and blind. This is the first case of complete reduction of compound eyes known in the insect order Psocoptera.

**Key-words:** Psocoptera - Sphaeropsocidae - *Sphaeropsocopsis* - eye reduction - cave species - St Helena island.

## INTRODUCTION

The Psocoptera of St Helena are poorly known. 12 species have been recorded by BADONNEL (1976); one of them has also been described under a synonym by NEW (1977). All this material has been collected on vegetation or in light traps, none from subterranean habitats. Among the several psocids collected by N. P. & M. J. Ashmole in such habitats one troglobitic species of the suborder Troctomorpha is of particular interest and will be described in the following.

During the period December 1994 to May 1995 N. P. Ashmole and M. J. Ashmole carried out intensive field work on the subterranean fauna of the island of St Helena, in mid-Atlantic in 5°W, 15°S. This work was stimulated by earlier studies on dispersal of island arthropods (ASHMOLE & ASHMOLE 1988) and on the fauna of lava and cave habitats on other volcanic Atlantic islands (ASHMOLE & ASHMOLE 1987, OROMÍ *et al.* 1990, ASHMOLE *et al.* 1992).

Geologically youthful volcanic islands such as Ascension sometimes have closely related endemic species respectively in barren lava habitats on the surface and in volcanic caves and smaller underground spaces (ASHMOLE 1994, ASHMOLE & ASHMOLE 1997, CHRISTIANSEN 1998). A degree of troglomorphy [morphological

specialization for subterranean life (CHRISTIANSEN 1962)] may be shown by cavernicolous species on such islands [e.g. pseudoscorpions (MAHNERT 1993); spiders (MERRETT & ASHMOLE 1997); psocids (LIENHARD 1996)] but is typically more extreme in caves on older islands, where true troglobites (species obligately associated with the deep cave zone) are often found (OROMÍ *et al.* 1991). However, underground caves and cracks formed at the time of volcanic eruptions are relatively ephemeral (HOWARTH 1981, ASHMOLE *et al.* 1992, HOCH & ASCHE 1993). Animals may evolve specializations to life in them, but as the caves collapse and the cracks become filled with soil, troglobites on islands may become extinct or survive in only a few localities.

The recent work on St Helena was designed to find any specialized cavernicolous arthropods that might have survived the period of about seven million years since volcanic activity on the island ceased (BAKER 1970); the species here described is the only unequivocal example encountered. Few lava tubes survive and near-surface subterranean spaces are inhabited largely by introduced soil animals (ASHMOLE & ASHMOLE, unpublished).

#### METHODS AND STUDY SITES

The traps used for sampling the fauna of underground spaces on St Helena were of three types: "pipe traps" (described in ASHMOLE & ASHMOLE, in press a), conventional plastic straight-sided pitfall traps (ASHMOLE *et al.* 1992) and specially designed "boot traps"; it was in one of the latter that the blind psocopteran was captured.

The boot traps are a form of pitfall trap modified for use in caves and other situations where it is impractical to bury traps with the rim flush with the substrate; they are ceramic and were commissioned from a local potter. The trap weighs a little under 400 g and is boot-shaped in profile, with base dimensions c. 125 mm long, c. 70 mm wide and c. 80 mm high. The "heel" of the boot is in the form of a straight-sided pitfall trap with internal dimensions c. 70 mm deep and c. 45 mm diameter; the "toe" forms a ramp up which arthropods can climb. The ramp is coarsely roughened to mimic the surface of lava or cinders but the interior of the trap is smooth and glazed; a broad glazed lip slopes down from the top of the ramp into the trap; on the other side of the trap opening the narrow roughened rim meets the glazed interior at a right-angle.

Each trap contains c. 25 ml of modified Turquin's liquid consisting of 10 g chloral hydrate, 5 ml formalin, 5 ml glacial acetic acid, 1 ml liquid detergent, plus beer (preferably including one third stout) to make 1 litre. In addition a bait of "Danish Blue" cheese is placed in a tiny plastic cup formed by an inverted specimen tube lid impaled on a nail with its point resting on the bottom of the trap, thus holding the bait dry above the level of the liquid.

Most of the work on St Helena involved setting traps in the network of small underground cracks and crevices characteristic of basaltic lava and termed the "MSS" or mesocavernous shallow stratum (JUBERTHIE *et al.* 1980, MEDINA & OROMÍ 1990,

ASHMOLE 1994). However, traps were also placed in the largest among the few accessible lava tubes, and it was in this cave that the blind psocid was captured.

The cave, referred to as Rupert's Battery Cave, is at UTM Grid Zone 30, TH 088 386 in northwest St Helena. The opening is at a height of roughly 50 m beside a path traversing a very steep and rocky slope above the shore between Rupert's Bay and James Bay. The opening had been blocked by a large rock which was moved in order to gain access to the cave. The cave slopes downwards very steeply to the north and may continue to sea level, but has been blocked with rubble at about four metres from the top, probably by people trying to make it less dangerous. The traps were set on the top of the rubble, mainly close to the cave walls, and were in semi-darkness; further down, the cave is presumably completely dark and also humid. Other arthropods caught in the cave included an unidentified and possibly endemic species of mogoplistine cricket, together with introduced species of blaniulid Diplopoda and lepismatid Thysanura (*Zygentoma*).

The following abbreviations are used in the description: B = body length; V = width of head capsule on vertex; FW = forewing length; F+tr = length of femur and trochanter (hindleg); T = length of tibia (hindleg); t1, t2, t3 = length of tarsomeres, measured from condyle to condyle (hindleg); MHNG = Muséum d'histoire naturelle de Genève.

## DESCRIPTION

### *Sphaeropsocopsis myrtleae* sp. n. (♀)

Figs 1-8

*Material.* Holotype ♀ (slide mounted, MHNG). St Helena: Rupert's Battery Cave, 13-17 March 1995, modified pitfall trap ("boot trap"), leg. N. P. & M. J. Ashmole (sample: 680 SH).

*Etymology.* The species is dedicated to Myrtle Ashmole, who in 1984 suggested studying the fauna of barren volcanic terrain in the Canary Islands and who participated in all the field work on St Helena.

*Coloration.* Body white to very slightly yellowish, no subcuticular pigment, cuticle transparent, the light brown mandibles visible through the head capsule. Wings, legs and antennae colorless.

*Sculpture.* Vertex with fine granular tubercles, their diameter distinctly smaller than the diameter of the alveoli of the small vertical hairs. Tubercles evenly distributed, no distinct spindle-shaped or polygonal areas recognizable. Sculpture of thoracic tergites similar to head.

*Morphology.* Compound eyes absent, no ocelli. Head capsule normally shaped but very slightly concave laterally where in the other species of the genus the compound eyes are located (fig. 1). Pilosity of head short, with a pair of distinctly longer hairs near antennal base and another pair on postclypeus, three of these hairs are broken but localizable by their large alveoli (fig. 1). Vertical suture well developed, frontal suture only visible as a slight interruption of sculpture. Both antennae broken, only a few basal segments left. Maxillary palps lacking (broken). Pilosity of labial palps badly damaged, but a particularly well developed club-like sensillum

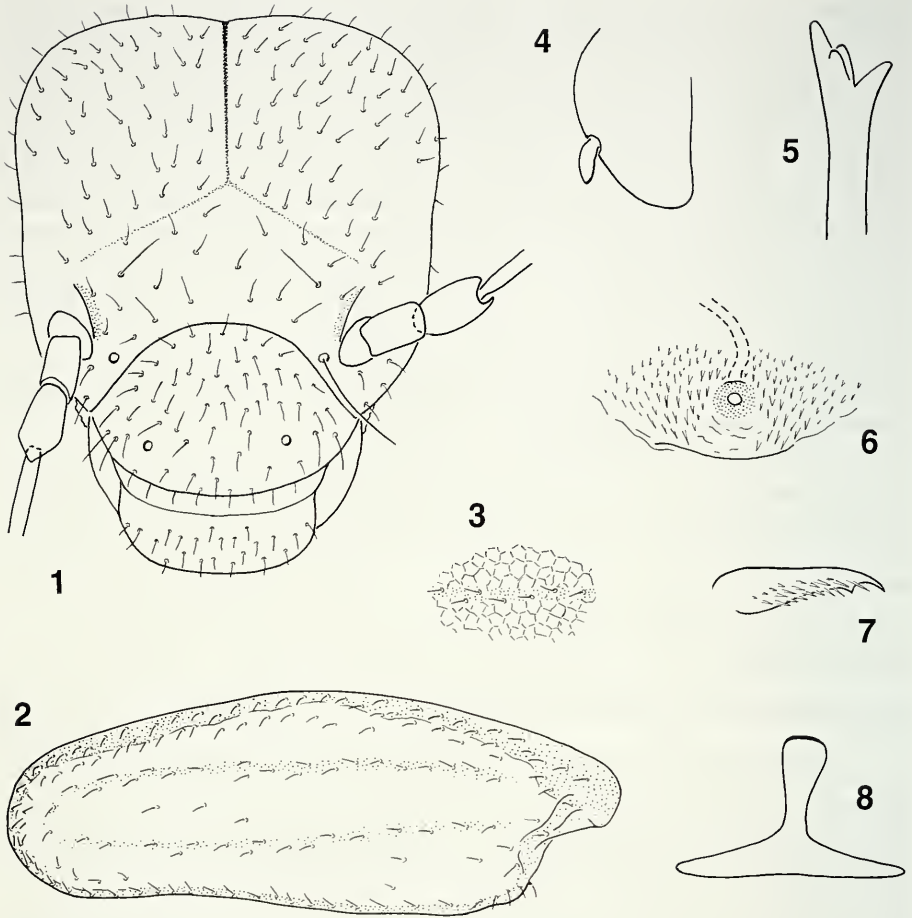

FIGS 1-8

*Sphaeropsocopsis myrtleae* sp. n., female: 1, head in frontal view; 2, forewing; 3, reticulate sculpture in the middle of forewing (same magnification as fig. 2); 4, labial palpus (pilosity not represented except large lateral sensillum); 5, lacinial tip; 6, spermapore; 7, claw; 8, T-shaped sclerite of subgenital plate.

present on outer side (fig. 4). Lacinial tip largely bifurcate, outer denticle with two secondary denticles on half-length on its inner side (fig. 5).

Thoracic tergites not divided into lobes. Forewings shortened, reaching about the middle of the abdomen, hindwings absent. Venation of forewing strongly reduced, two longitudinal rows of hairs indicate the presence of two faint longitudinal main veins, wing margins also rather densely pubescent, all hairs short (fig. 2). Wing membrane with a very faint network of fine sculptural lines delimiting more or less hexagonal areas (only visible at high magnifications under phase contrast) (fig. 3).



Legs relatively long (index T/V = 1.4), tibiae with two apical spurs, claws slender, with one preapical denticle and some microtrichia on outer side (fig. 7). No coxal organ present.

Terminalia without particular diagnostic characters, T-shaped sclerite of subgenital plate well developed (fig. 8), spermapore on both sides with a field of microtrichia (fig. 6). The spermatheca is full of sperm, therefore we can affirm that the species is bisexual, even if the male is not yet known.

*Measurements* ( $\mu\text{m}$ ). B = 1350; V = 315; FW = 580; F+tr = 360; T = 450; t1 = 150; t2 = 43; t3 = 60.

## DISCUSSION

At present the new species has to be placed in the genus *Sphaeropsocopsis* Badonnel, 1963 because mesothoracic sternites are not subdivided into lobes and because of the eye reduction. In the very closely related genus *Badonnelia* Pearman, 1953 females always have compound eyes with 7 (exceptionally 6 or 8) ommatidia and the mesothoracic sternites show some lobation. The generic characters of the forewing (shape and venation) can not be observed in the new species because of its strong brachyptery. According to BADONNEL (1963), the form of the terminal segment of the maxillary palp is also of some value to decide about generic attribution; unfortunately both palps are broken in the unique female of the new species.

Within the genus *Sphaeropsocopsis* the number of ommatidia in females can vary from 3 to 10, but intraspecific variability is usually low. Even in *S. microps*, the only species of the genus with 3 ommatidia (sometimes 4), these remaining ommatidia are well developed and situated on a hemispherical protuberance of the head capsule, as usual in the species with higher numbers of ommatidia. The complete reduction of the compound eyes in *S. myrtleae* clearly represents an adaptation to cave life and is the first case of blindness known in Psocoptera. Several troglomorphic psocids have been mentioned by BADONNEL & LIENHARD (1994), some of them show strong reduction of compound eyes but a blind species has never been observed up to now. Even in the edaphic species of the apterous genus *Liposcelis* Motschulsky, 1852 (belonging to the Liposcelididae, family closely related to the Sphaeropsocidae), where strong eye reduction occurs, at least two ommatidia always persist, forming together with some underlying pigment a reduced but probably functional compound eye (cf. LIENHARD 1998). The only known troglomorphic liposcelidid, *Troglotroctes ashmoleorum* Lienhard, 1996, has usually 3 (rarely 4 or 2) ommatidia (cf. LIENHARD 1996). In *S. myrtleae* however, the head capsule shows no subcuticular pigmentation or irregularity of sculpture at the place where eyes are usually located.

Unfortunately the antennae and the maxillary palps of the single specimen known are broken. Therefore it is impossible to say if in *S. myrtleae* the optical deficiency could eventually be compensated by tactile sense organs, as long antennae and palps with particularly well developed sensilla. But it is interesting to see that the club-like outer sensillum of the labial palp is extremely well developed in this species, significantly greater than is usual in Troctomorpha. In the troglomorphic *Troglotroctes*

*ashmoleorum*, known from subterranean habitats on Ascension Island (ASHMOLE & ASHMOLE 1997) an augmented number of sensilla on maxillary and labial palps has been observed, compared with the usual number in the family Liposcelididae (LIENHARD 1996). The relatively long legs (index T/V = 1.4) of *S. myrtleae* could probably also be interpreted as an adaptation to cave life, in the other species of the genus this index is  $\leq 1.0$  (cf. BADONNEL 1962, 1963, 1967, 1971, 1972). Another evident adaptation to subterranean life is the lack of pigmentation, which has never been observed to such an extent in the other species of the genus, which are usually litter-dwellers (cf. BADONNEL, papers cited above).

The presence of a species of *Sphaeropsocopsis* on the mid-Atlantic island of St Helena is not really surprising. The genus is known from South America, Ascension Island (mid-Atlantic), Africa, South Australia and Tasmania. A single species is known in each case from the Australian region [*S. recens* (Hickman, 1934); cf. SMITHERS 1984] and continental Africa [*S. reisi* Badonnel, 1971, only recorded from Angola (BADONNEL 1971)]. The highest diversity has been observed in South America, where one species is known from Argentina [*S. argentina* (Badonnel, 1962)] and 5 species from Chile: *S. chilensis* Badonnel, 1963; *S. microps* Badonnel, 1963; *S. spinosa* Badonnel, 1972; *S. valdiviensis* Badonnel, 1972; *S. valeriae* Badonnel, 1967. A single damaged female of *Sphaeropsocopsis* cf. *microps* has also been recorded from a subterranean habitat on Ascension Island (ASHMOLE & ASHMOLE 1997).

St Helena, which is more than 14 million years old (BAKER 1970) has been colonised during its long life by a wide variety of arthropod groups (BASILEWSKY 1985; ASHMOLE & ASHMOLE, in press b). Psocoptera, including even apterous forms such as *Liposcelis* species, are effective aerial dispersers (THORNTON 1964, THORNTON & HARRELL 1965) and the ancestors of *Sphaeropsocopsis myrtleae* seem likely to have colonised St Helena by air. There are endemic psocids on many oceanic islands, and on Ascension Island (the closest land to St Helena) there are several apparently indigenous species including a troglobitic generic endemic (*Troglotractes* Lienhard, 1996, see above and ASHMOLE & ASHMOLE 1997).

#### ACKNOWLEDGEMENTS

Field work by N. P. & M. J. Ashmole on St Helena was made possible by support from the Carnegie Trust for the Universities of Scotland and the British Ecological Society. It is a pleasure also to thank the many people on the island who helped to make the visit so productive and enjoyable.

#### REFERENCES

- ASHMOLE, M. J. & ASHMOLE, N. P. 1987. Arthropod communities supported by biological fallout on recent lava flows in the Canary Islands. *Entomologica Scandinavica, Supplement* 32: 67-88.
- ASHMOLE, N. P. 1994. Colonization of the underground environment in volcanic islands. *Mémoires de Biospéologie* 20: 1-11.

- ASHMOLE, N. P. & ASHMOLE, M. J. 1988. Insect dispersal on Tenerife, Canary Islands: high altitude fallout and seaward drift. *Arctic and Alpine Research* 20: 1-12.
- ASHMOLE, N. P. & ASHMOLE, M. J. 1997. The land fauna of Ascension Island: new data from caves and lava flows, and a reconstruction of the prehistoric ecosystem. *Journal of Biogeography* 24: 549-589.
- ASHMOLE, N. P. & ASHMOLE, M. J. (in press a). Arthropod fallout supporting lava communities. In: WILKENS, H., CULVER, D. & HUMPHREYS, W. (eds). Subterranean ecosystems. Ecosystems of the World, vol. 30. *Elsevier Science*.
- ASHMOLE, N. P. & ASHMOLE, M. J. (in press b). St Helena and Ascension Island: Origins, evolution and natural history. *Anthony Nelson Publisher, Oswestry, U. K.*
- ASHMOLE, N. P., OROMÍ, P., ASHMOLE, M. J. & MARTÍN, J. L. 1992. Primary faunal succession in volcanic terrain: lava and cave studies on the Canary Islands. *Biological Journal of the Linnean Society* 46: 207-234.
- BADONNEL, A. 1962. Psocoptères. *Biologie de l'Amérique australe* 1: 185-229.
- BADONNEL, A. 1963. Psocoptères terricoles, lapidicoles et corticicoles du Chili. *Biologie de l'Amérique australe* 2: 291-338.
- BADONNEL, A. 1967. Psocoptères édaphiques du Chili (2e note). *Biologie de l'Amérique australe* 3: 541-585.
- BADONNEL, A. 1971. *Sphaeropsocopsis reisi* n. sp., premier représentant africain connu de la famille des Sphaeropsocidae (Psocoptera, Nanopsocetae), avec compléments à la faune des Psocoptères angolais. *Publicações culturais da Companhia de Diamantes de Angola* 84: 13-28.
- BADONNEL, A. 1972. Psocoptères édaphiques du Chili (3e note) (Insecta). *Bulletin du Muséum national d'Histoire naturelle* (3)(1)(1971) *Zoologie* 1: 1-38.
- BADONNEL, A. 1976. La faune terrestre de l'île de Sainte-Hélène. Psocoptera. *Annales du Musée Royal de l'Afrique centrale, Sciences zoologiques* 215: 206-232.
- BADONNEL, A. & LIENHARD, C. 1994. Psocoptera (pp. 301-305). In: JUBERTHIE, C. & DECU, V. (eds). *Encyclopaedia Biospeologica*, tome I, XII + 834 pp. *Société de Biospéologie, Moulis*.
- BAKER, I. 1970. La faune terrestre de l'île de Sainte-Hélène. Geological history of Saint Helena in relation to its floral and faunal colonization. *Annales du Musée Royal de l'Afrique centrale, Sciences zoologiques* 181: 23-36.
- BASILEWSKY, P. 1985. The South Atlantic island of Saint Helena and the origin of its beetle fauna (pp. 257-275). In: BALL, G. E. (ed.). *Taxonomy, phylogeny and zoogeography of beetles and ants*. Dr W. Junk Publishers, Dordrecht.
- CHRISTIANSEN, K. 1962. Proposition pour la classification des animaux cavernicoles. *Spelunca Mémoires* 2: 76-78.
- CHRISTIANSEN, K. A. 1998. New species of *Pseudosinella* (Collembola) from Ascension Island. *Journal of Natural History* 32: 149-156.
- HOCH, H. & ASCHE, M. 1993. Evolution and speciation of cave-dwelling Fulgoroidea in the Canary Islands (Homoptera: Cixiidae and Meenoplidae). *Zoological Journal of the Linnean Society* 109: 53-101.
- HOWARTH, F. G. 1981. Community structure and niche differentiation in Hawaiian lava tubes (pp. 318-336). In: MUELLER-DOMBOIS, D., BRIDGES, K. W. & CARSON, L. (eds.). *Island ecosystems. Biological organization in selected Hawaiian communities*. *US/IBP Synthesis Series* 15.
- JUBERTHIE, C., DELAY, B. & BOUILLON, M. 1980. Sur l'existence d'un milieu souterrain superficiel en zone non calcaire. *Comptes Rendus Hebdomadaires des Séances, Académie des Sciences (Paris)*, 290, Série D: 49-52.
- LIENHARD, C. 1996. Psocoptères nouveaux ou peu connus de quelques îles atlantiques (Canaries, Madère, Açores, Ascension) et de l'Afrique du Nord (Insecta: Psocoptera). *Boletim do Museu municipal do Funchal (Historia Natural)* 48(267): 87-151.

- LIENHARD, C. 1998. Psocoptères euro-méditerranéens. *Faune de France* 83: XX + 517 pp.
- MAHNERT, V. 1993. Pseudoskorpione (Arachnida: Pseudoscorpiones) von Inseln des Mittelmeers und des Atlantiks (Balearen, Kanarische Inseln, Madeira, Ascension), mit vorwiegend subterranean Lebensweise. *Revue suisse de Zoologie* 100: 971-992.
- MEDINA, A. L. & OROMÍ, P. 1990. First data on the superficial underground compartment in La Gomera (Canary Islands). *Mémoires de Biospéologie* 17: 87-91.
- MERRETT, P. & ASHMOLE, N. P. 1997. Redescription of *Catonetria caeca* Millidge & Ashmole from Ascension Island (Araneae: Linyphiidae). *Bulletin of the British Arachnological Society* 10: 247-248.
- NEW, T. R. 1977. A new species of *Blaste* (Psocoptera, Psocidae) from St. Helena. *Nouvelle Revue d'Entomologie* 7(3): 253-256.
- OROMÍ, P., MARTÍN, J. L., ASHMOLE, N. P. & ASHMOLE, M. J. 1990. A preliminary report on the cavernicolous fauna of the Azores. *Mémoires de Biospéologie* 17: 97-105.
- OROMÍ, P., MARTÍN, J. L., MEDINA, A. L. & IZQUIERDO, I. 1991. The evolution of the hypogean fauna in the Canary Islands (pp. 380-395). In: DUDLEY, E. C. (ed.). The unity of evolutionary biology. *Dioscorides Press, Portland, Oregon*.
- SMITHERS, C. N. 1984. The Psocoptera (Insecta) of South Australia. *Records of the South Australian Museum* 18(20): 453-491.
- THORNTON, I. W. B. 1964. Air-borne Psocoptera trapped on ships and aircraft. *Pacific Insects* 6(2): 285-291.
- THORNTON, I. W. B. & HARRELL, J. C. 1965. Air-borne Psocoptera trapped on ships and aircraft. 2. Pacific ship trappings 1963-1964. *Pacific Insects* 7(4): 700-702.

## New species of *Agathidium* Panzer from China (Coleoptera, Leiodidae, Agathidiini)

Fernando ANGELINI

S.S.7 per Latiano, Km. 0,500, I-72021 Francavilla Fontana (Brindisi), Italy.

**New species of *Agathidium* Panzer from China (Coleoptera, Leiodidae, Agathidiini).** - Records and/or descriptions are given for 13 species of *Agathidium* from China (Sichuan), deposited in the Geneva Museum and collected by Dr. S. Kurbatov. New species are: *Agathidium* (*Agathidium*) *modestum* sp. n., *A.* (*A.*) *armatum* sp. n., *A.* (*A.*) *rubiginosum* sp. n., *A.* (*A.*) *hani* sp. n., *A.* (*A.*) *luojense* sp. n., *A.* (*A.*) *pseudouniforme* sp. n., *A.* (*Microceble*) *xilingense* sp. n., *A.* (*Macroceble*) *kurbatovianum* sp. n., *A.* (*M.*) *megacephalum* sp. n. New records for Sichuan are: *Agathidium* (*Agathidium*) *brunneipenne* Ang. & Dmz. and *A.* (*A.*) *lugubre* Ang. & Dmz.

**Key-words:** Coleoptera - Leiodidae - *Agathidium* - China - new species - new records.

### INTRODUCTION

A large amount of new data on the *Agathidium* fauna of China results from a study of the material deposited in the Geneva Museum. The collection treated consists of 102 specimens and 13 species collected in 4 localities of the Sichuan Province.

The new data concern:

- a) 9 new species.
- b) 2 new records for Sichuan: *Agathidium* (*Agathidium*) *brunneipenne* Ang. & Dmz. and *A.* (*A.*) cf. *lugubre* Ang. & Dmz.

The Chinese Agathidiini are moderately known. With the new species are known 80 species, collected mainly in Sichuan, Yunnan and Zhejiang Province. The majority of species are endemic; only 6 species are present in Taiwan or Oriental Region.

The specimens are deposited in the Geneva Museum (MHNG) and in Angelini's collection in Genoa Natural History Museum (AC-GNHM). For methods see ANGELINI & DE MARZO (1981: 188-192).

I am indebted to Dr Ivan Löbl for making the material available for study and to Jonathan Cooter (Hereford) for comments on the earlier version of the manuscript.

**Agathidium** Panzer, 1797**Agathidium (Neoceble) dundai** Ang. & Svec

*Agathidium (Neoceble) dundai* Angelini & Svec, 1994: 12.

Material: China, Sichuan, Xiling Mt., 1600-2400 m, 30.VII-4.VIII.1996, leg. S. Kurbatov, 1 ex. ♀ in MHNG.

Distribution: China (Sichuan).

**Agathidium (Agathidium) modestum** sp. n.

Figs 1, 7-9, 16

Holotype ♂: China, Sichuan, env. Xichang, M. Luoji, 2300-2400 m, 16-24.VII.1996, leg. S. Kurbatov, in MHNG.

Paratypes: Same data as holotype. 7 ♂ and 8 ♀ in MHNG. 3 ♂ and 2 ♀ in AC-GNHM.

Length 2,6-3,0 mm (holotype ♂ 2,90 mm). Dorsum reddish-brown, venter lighter; antennae uniformly testaceous; legs reddish-brown. Microreticulation absent; puncturation fine and sparse on whole dorsum. Sutural striae absent.

Head: Punctures very small, superficial, separated from each other by 2-10 times their own diameter. Widest at the eyes; eyes flattened (fig. 1); antero-lateral margins distinctly raised; clypeus moderately emarginate; clypeal line absent. 3rd antennal segment 1,27 times as long as 2nd and shorter than 4th + 5th together.

Pronotum: Punctures as those on head, separated from each other by 2-15 times their own diameter. 1,59 times as broad as head, moderately broader than long (width/length= 1,55) and very convex (width/height= 1,4); anterior margin weakly curved; lateral outline broadly rounded. Measurements of pronotum of holotype: length 0,90 mm, width 1,40 mm and height 1,00 mm.

Elytra: Punctures as those on head, separated from each other by 2-5 times their own diameter. As broad as pronotum, a little broader than long (width/length= 1,03) and moderately convex (width/height= 1,79); lateral outline with humeral angle very broadly rounded. Measurements of elytra of holotype: length 1,35 mm, width 1,40 mm and height 0,78 mm.

Metathoracic wings absent. Meso- and metasternum: median carina absent, lateral lines absent, femoral lines complete, a small tubercle present between the metacoxae; metasternum short, meso- and metacoxae almost touching.

Legs: Male hind femora curved at posterior margin (fig. 16). Tarsal formula: ♂ 5-5-4, ♀ 4-4-4.

Aedeagus as in figures 7. 8. Spermatheca as in figure 9.

Discussion: Species of the *madurensis* group; *Agathidium modestum* sp. n. is similar to *A. alesi* Ang. & Dmz. (from Taiwan) and *A. distinguendum* Ang. & Dmz. (from Taiwan); from *A. distinguendum* it differs in shape of eyes, greater length, and in having the pronotum less transverse; from *A. alesi* it differs only in shape of pronotum, which is less transverse and male hind femora, without tooth at posterior margin.

Distribution: China (Sichuan).

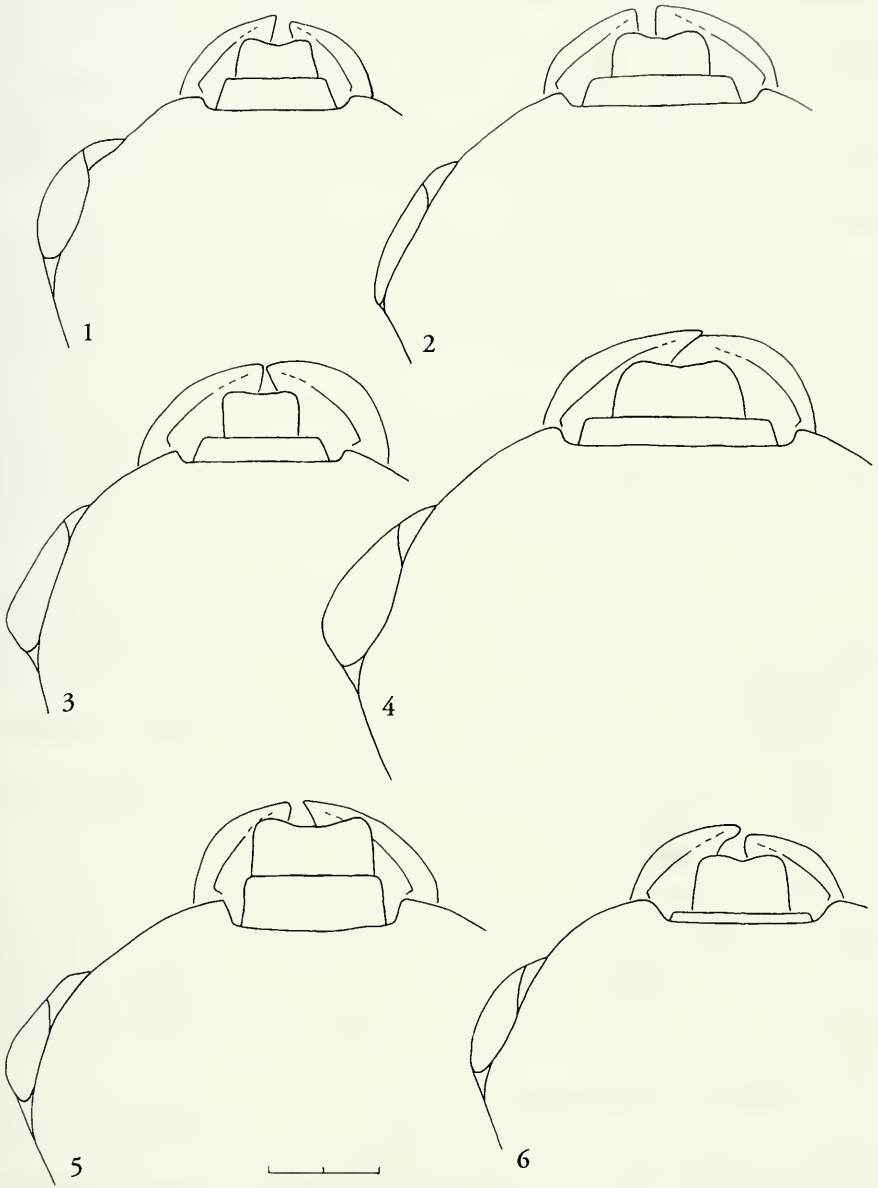

FIGS 1-6

Head of: 1, *Agathidium modestum* sp. n.; 2, *A. armatum* sp. n.; 3, *A. rubiginosum* sp. n.; 4, *A. hani* sp. n.; 5, *A. luojiense* sp. n.; 6, *A. pseudouniforme* sp. n.

**Agathidium (Agathidium) armatum** sp. n.

Figs 2, 10-12, 17

Holotype ♂: China, Sichuan, M. Xiling, 1600-2400 m, 30.VII.-4.VIII.1996, leg. S. Kurbatov, in MHNG.

Paratypes: Same data as holotype, 2 ♂ and 5 ♀ in MHNG, 2 ♂ and 1 ♀ in AC-GNHM.

Length 2,85-3,10 mm (holotype ♂ 3,00 mm). Dorsum reddish-brown, venter lighter; antennae uniformly testaceous; legs reddish-brown. Microreticulation present only on the elytra, impressed; puncturation fine and sparse on head and pronotum, absent on elytra. Sutural striae absent.

Head: Microreticulation absent; punctures small, impressed, separated from each other by 2-5 times their own diameter. Widest at the eyes; eyes flattened (fig. 2); antero-lateral margins uniformly raised; clypeus moderately emarginate; clypeal line absent. 3rd antennal segment 2,36 times as long as 2nd and longer than 4th + 5th together.

Pronotum: Microreticulation absent; punctures smaller and more superficial than those on the head, hardly visible, separated from each other by 2-10 times their own diameter. 1,33 times as broad as head, moderately broader than long (width/length= 1,47) and moderately convex (width/height= 1,47); anterior margin moderately curved; lateral outline broadly rounded. Measurements of pronotum of holotype: length 0,95 mm, width 1,40 mm and height 0,95 mm.

Elytra: Microreticulation impressed and uniform; without puncturation. Slightly narrower than the pronotum, as broad as long and weakly convex (width/height= 1,87); lateral outline with humeral angle very broadly rounded. Measurements of elytra of holotype: length 1,35 mm, width 1,35 mm and height 0,72 mm.

Metathoracic wings absent. Meso- and metasternum: median carina sharp, lateral lines absent, femoral lines complete, rounded at middle.

Legs: Male hind femora with a sharp tooth at the posterior margin (fig. 17). Tarsal formula: ♂ 5-5-4, ♀ 5-4-4.

Aedeagus as in figures 10, 11. Spermatheca as in figure 12.

Discussion: Species of the *laevigatum* group; *Agathidium armatum* sp. n. is similar to *A. rubiginosum* sp. n. (from Sichuan) and *A. rufescens* Ang. & Dmz. (from Sichuan) in colouring of dorsum, length ratio 3rd/2nd and in microreticulation only on elytra; it differs in shape of eyes, very long and flattened. The male and female genitalia also exhibit marked differences and reference to these is necessary for precise determination.

Distribution: China (Sichuan).

**Agathidium (Agathidium) procerum** Ang. & Dmz.

*Agathidium (Agathidium) procerum* Angelini & De Marzo, 1998: 359.

Material: China, Sichuan, Mt. Xiling, 1600-2400 m, 30.VII.-4.VIII.1996, leg. S. Kurbatov, 5 ex. in MHNG and AC-GNHM.

Distribution: China (Sichuan).



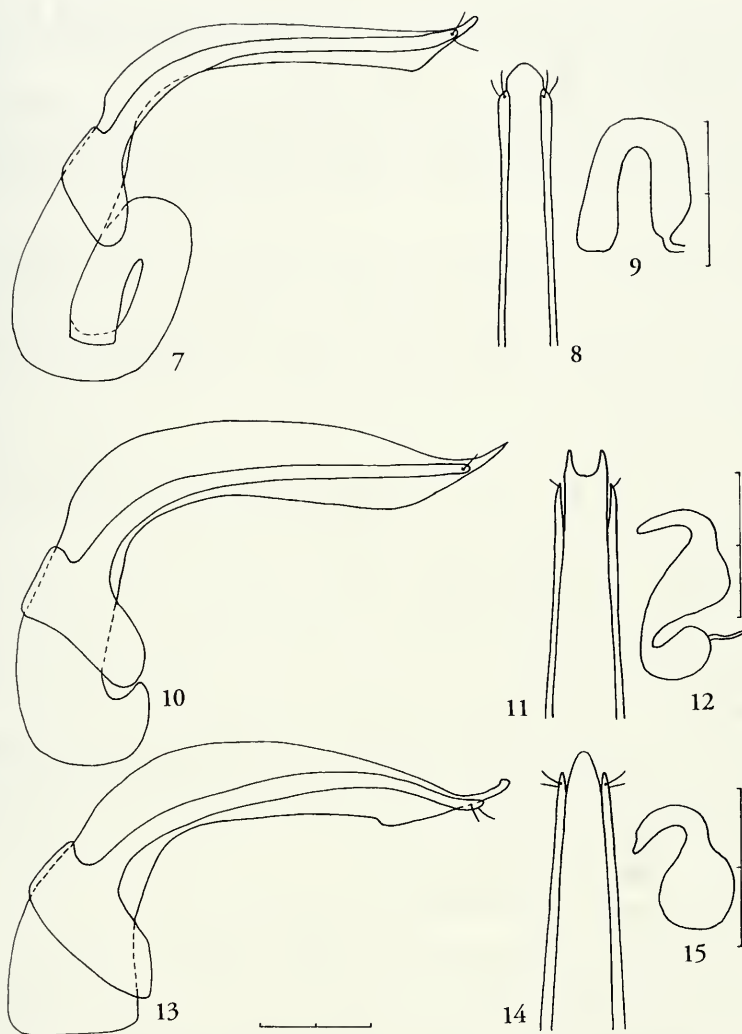

FIGS 7-15

Aedeagus (lateral and dorsal view of its apex) and spermatheca of: 7-9, *Agathidium modestum* sp. n.; 10-12, *A. armatum* sp. n.; 13-15, *A. rubiginosum* sp. n.

***Agathidium (Agathidium) rubiginosum* sp. n.**

Figs 3, 13-15, 18

Holotype ♂: China, Sichuan, Mt. Xiling, 1600-2400 m. 30.VII.-4.VIII.1996, leg. S.Kurbatov, in MHNG.

Paratypes: Same data as holotype, 1 ♂ in MHNG, 1 ♂ and 1 ♀ in AC-GNHM.

Length 3,05-3,15 mm (holotype ♂ 3,15 mm). Dorsum reddish-brown; meso-sternum testaceous, metasternum reddish-brown; antennae uniformly testaceous; legs

reddish-brown. Microreticulation present only on the elytra, superficial, more impressed on female; puncturation fine and sparse on head and pronotum, absent on elytra. Sutural striae absent.

Head: Microreticulation absent; punctures small, superficial, separated from each other by 2-6 times their own diameter. Widest at the eyes; eyes flattened (fig. 3); antero-lateral margins uniformly raised; clypeus slightly emarginate; clypeal line absent. 3rd antennal segment 2,4 times as long as 2nd and longer than 4th + 5th together.

Pronotum: Microreticulation absent; punctures smaller and more superficial than those on the head, separated from each other by 1-15 times their own diameter. 1,59 times as broad as head, moderately broader than long (width/length= 1,42) and moderately convex (width/height= 1,56); anterior margin sharply curved; lateral outline broadly rounded. Measurements of pronotum of holotype: length 1,05 mm, width 1,50 mm and height 0,96 mm.

Elytra: Microreticulation superficial and uniform; puncturation absent. Slightly narrower than the pronotum, as broad as long and weakly convex (width/height= 1,86); lateral outline with humeral angle very broadly rounded. Measurements of elytra of holotype: length 1,40 mm, width 1,40 mm and height 0,75 mm.

Metathoracic wings absent. Meso- and metasternum: median carina weak, lateral lines absent, femoral lines incomplete, rounded at middle.

Legs: Male hind femora with a sharp tooth at the posterior margin (fig.18). Tarsal formula: ♂ 5-5-4, ♀ 5-4-4.

Aedeagus as in figures 13, 14. Spermatheca as in figure 15.

Discussion: See *Agathidium armatum* sp. n.; from *A. rufescens* Ang. & Dmz. (from Sichuan) it differs in greater width ratio pronotum/head and in shape of pronotum, less transverse.

Distribution: China (Sichuan).

### **Agathidium (Agathidium) brunneipenne** Ang. & Dmz.

*Agathidium (Agathidium) brunneipenne* Angelini & De Marzo, 1998: 363.

Material: China, Sichuan, Mt. Xiling, 1600-2400 m, 30.VII.-4.VIII.1996, leg. S. Kurbatov, 1 ♀ in MHNG.

Distribution: China (Hubei, Sichuan). New record for Sichuan.

### **Agathidium (Agathidium) cf. lugubre** Ang. & Dmz.

*Agathidium (Agathidium) lugubre* Angelini & De Marzo, 1998: 365.

Material: China, Sichuan, Mt. Xiling, 1600-2400 m, 30.VII.-4.VIII.1996, leg. S. Kurbatov, 3 ♀ in MHNG (tentative determination based on female specimens).

Distribution: China (Guangxi, Sichuan). New record for Sichuan.

### **Agathidium (Agathidium) hani** sp. n.

Figs 4, 19, 25-27

Holotype ♂: China, Sichuan, M. Emei, VII.1980, leg. Jäch in AC-GNHM.

Paratypes: China, Sichuan, Mt. Xiling, 1600-2400 m, 30.VII.-4.VIII.1996, leg. S. Kurbatov, 1 ♀ in MHNG, 1 ♀ in AC-GNHM.

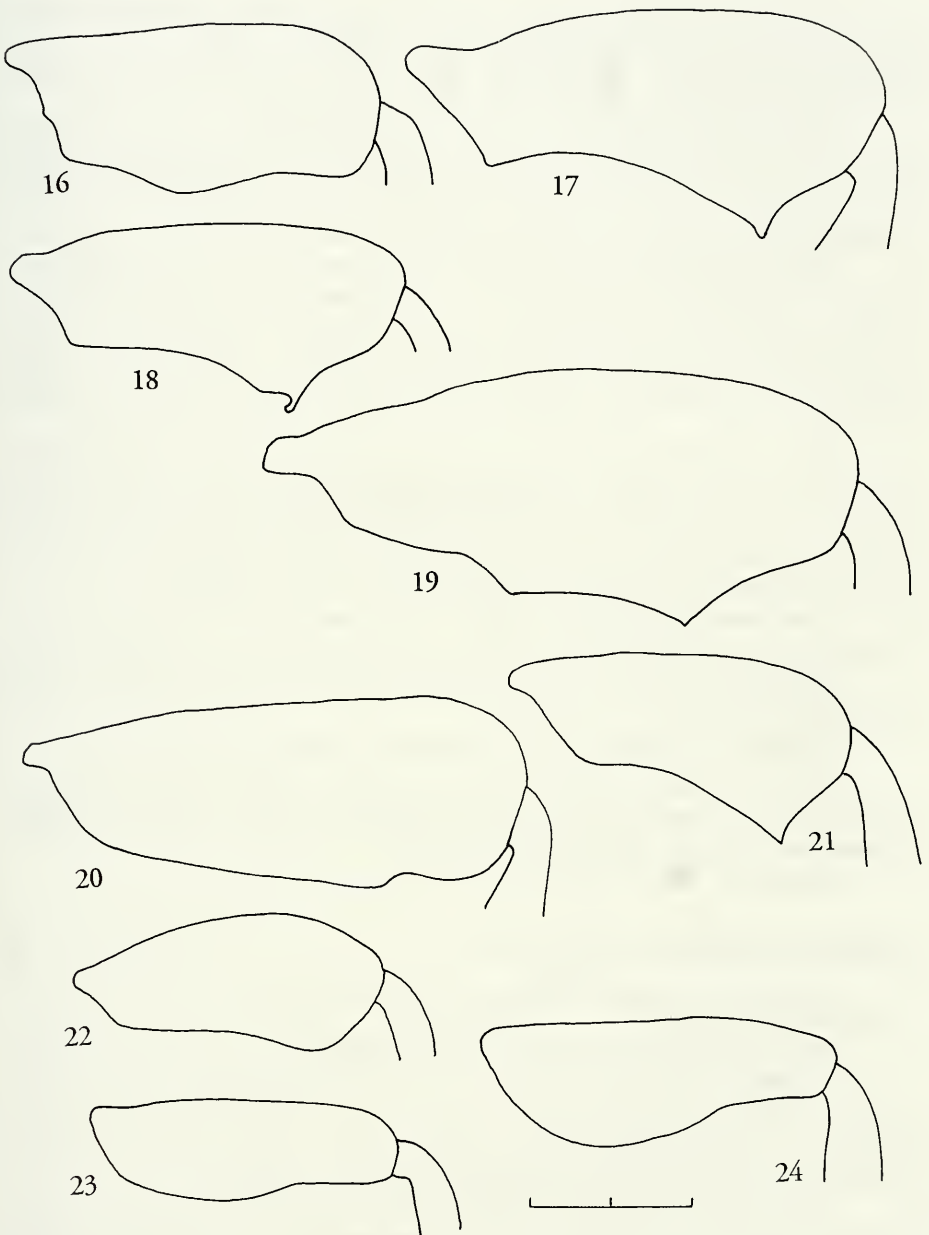

FIGS 16-24

Male hind femora of: 16, *Agathidium modestum* sp. n.; 17, *A. armatum* sp. n.; 18, *A. rubiginosum* sp. n.; 19, *A. hani* sp. n.; 20, *A. luojiense* sp. n.; 21, *A. pseudouniforme* sp. n.; 22, *A. xiliugense* sp. n.; 23, *A. kurbatovianum* sp. n.; 24, *A. megacephalum* sp. n.

Length 3,8-4,4 mm (holotype ♂ 4,40 mm). Dorsum dark reddish-brown, venter reddish-brown, mesosternum lighter; antennae uniformly testaceous; legs reddish-brown. Microreticulation almost absent, present only in traces on the elytra; puncturation fine and sparse on whole dorsum. Sutural striae absent.

Head: Punctures very small, superficial, separated from each other by 4-10 times their own diameter. Widest at the eyes; eyes flattened (fig. 4); antero-lateral margins uniformly raised; clypeus moderately emarginate; clypeal line absent. 3rd antennal segment 2 times as long as 2nd and longer than 4th + 5th together.

Pronotum: Punctures smaller and more superficial than those on the head, hardly visible, separated from each other by 4-15 times their own diameter. 1,62 times as broad as head, weakly broader than long (width/length= 1,34) and very convex (width/height= 1,43); anterior margin sharply curved; lateral outline broadly rounded. Measurements of pronotum of holotype: length 1,55 mm, width 2,08 mm and height 1,45 mm.

Elytra: Microreticulation present only in traces; punctures as on head but separated from each other by 1-5 times their own diameter; slightly narrower than the pronotum, a little longer than broad (width/length= 0,97) and weakly convex (width/height= 1,9); lateral outline with humeral angle very broadly rounded. Measurements of elytra of holotype: length 1,95 mm, width 1,90 mm and height 1,00 mm.

Metathoracic wings absent. Meso- and metasternum: median carina weak, lateral lines absent, femoral lines incomplete, rounded at middle.

Legs: Male hind femora with two tooth at the posterior margin (fig.19). Tarsal formula: ♂ 5-5-4, ♀ 5-4-4.

Aedeagus as in figures 25, 26. Spermatheca as in figure 27.

Discussion: Species of the *dentatum* group; *Agathidium hani* sp. n. is similar to *A. lugubre* Ang. & Dmz. (from Guangxi): it differs in shape of male hind femora, aedeagus and in greater width ratio pronotum/head.

Distribution: China (Sichuan).

### **Agathidium (Agathidium) luojiense** sp. n.

Figs 5, 20, 28-30

Holotype ♂: China, Sichuan, Xichang, M. Luoji. 2300-2500 m, 16.-24.VII.1996, leg. S. Kurbatov, in MHNG.

Paratypes: Same data as holotype, 5 ♂ and 8 ♀ in MHNG, 2 ♂ and 2 ♀ in AC-GNHM.

Length 3,25-3,50 mm (holotype ♂ 3,45 mm). Dorsum reddish-brown; mesosternum reddish-brown, metasternum black; antennae uniformly testaceous; legs reddish-brown. Microreticulation almost absent, present only in traces on the elytra; puncturation fine and sparse on whole dorsum. Sutural striae absent.

Head: Punctures very small, superficial, separated from each other by 1-10 times their own diameter. Widest at the eyes; eyes flattened (fig. 5); antero-lateral margins uniformly raised; clypeus moderately emarginate; clypeal line absent. 3rd antennal segment 1.3 times as long as 2nd and as long as the 4th + 5th together.

Pronotum: Puncturation as that of head. 1,42 times as broad as head, moderately broader than long (width/length= 1,57) and very convex (width/height= 1,4); anterior

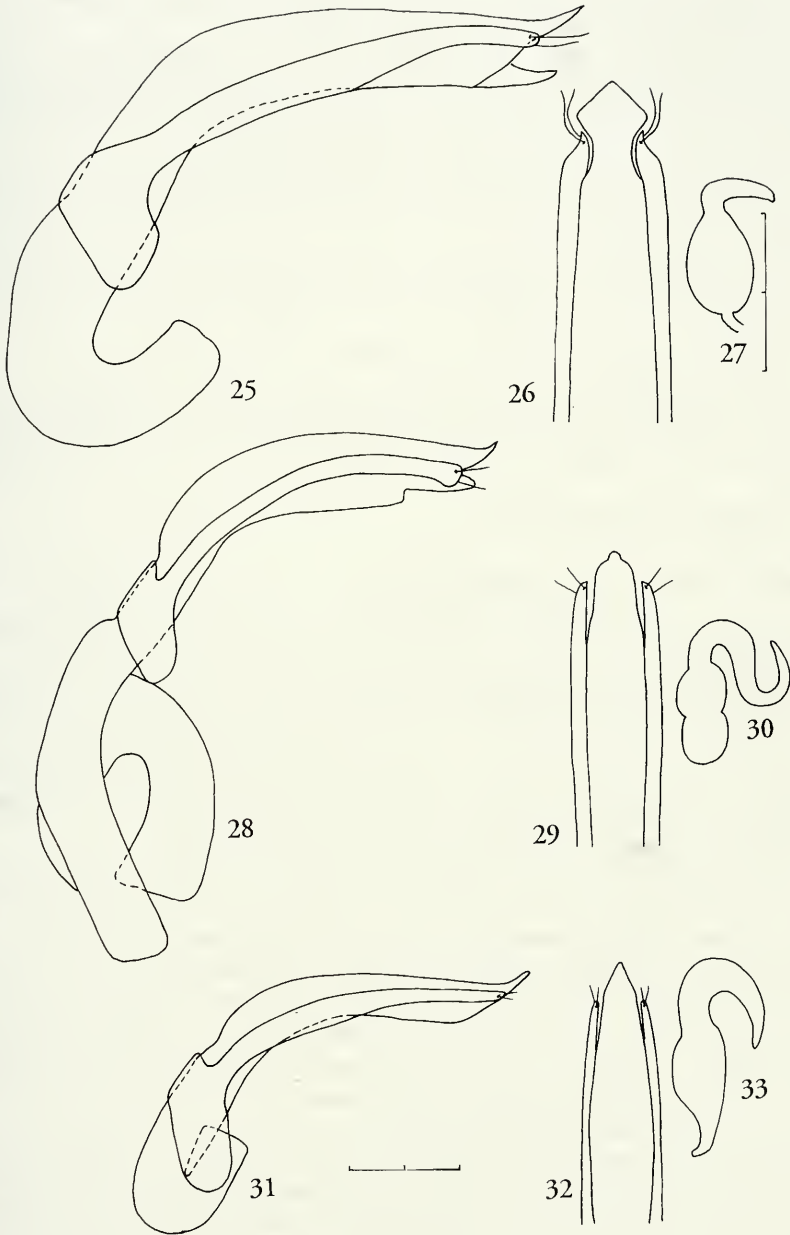

FIGS 25-33

Aedeagus (lateral and dorsal view of its apex) and spermatheca of: 25-27, *Agathidium hani* sp. n.; 28-30, *A. luojiense* sp. n.; 31-33, *A. pseudouniforme* sp. n.

margin sharply curved; lateral outline broadly rounded. Measurements of pronotum of holotype: length 1,03 mm, width 1,62 mm and height 1,15 mm.

Elytra: Microreticulation almost absent, only traces; puncturation as that of head. As broad as pronotum, as broad as long and moderately convex (width/height= 1,8); lateral outline with humeral angle very broadly rounded. Measurements of elytra of holotype: length 1,62 mm, width 1,62 mm and height 0,90 mm.

Metathoracic wings absent. Meso- and metasternum: median carina absent, lateral lines absent, femoral lines short, rounded at middle; metasternum short, meso- and metacoxae almost touching.

Legs: Male hind femora curved at posterior margin (fig.20). Tarsal formula: ♂ 5-5-4, ♀ 5-4-4.

Aedeagus as in figures 28, 29. Spermatheca as in figure 30.

Discussion: Species of the *dentatum* group; *Agathidium luojiense* sp. n. is similar to *A. huaense* Ang. & Dmz. and *A. pseudouniforme* sp. n.; it differs only in lesser length ratio 3rd/2nd antennal segments, in shape of male hind femora and aedeagus.

Distribution: China (Sichuan).

### **Agathidium (Agathidium) pseudouniforme** sp. n.

Figs 6, 21, 31-33

Holotype ♂: China, Sichuan, Xichang, M. Luoji, 2300-2500 m, 16.-24.VII.1996, leg. S. Kurbatov, in MHNG.

Paratypes: Same data as holotype, 4 ♂ and 9 ♀ in MHNG, 3 ♂ and 2 ♀ in AC-GNHM; Sichuan, env. Xichang, 1600 m, 28.VII.1996, leg. S. Kurbatov, 4 ♀ in MHNG.

Length 2,5-3,2 mm (holotype ♂ 2,90 mm). Dorsum reddish-brown; venter reddish-brown, mesosternum lighter; antennae uniformly testaceous; legs reddish-brown. Microreticulation present only in traces at sides of pronotum and on the elytra; puncturation fine and sparse on whole dorsum. Sutural striae absent.

Head: Punctures very small, superficial, separated from each other by 1-10 times their own diameter. Widest at the eyes; eyes flattened (fig. 6); antero-lateral margins uniformly raised; clypeus moderately emarginate; clypeal line absent. 3rd antennal segment 1.7 times as long as 2nd and longer than 4th + 5th together.

Pronotum: Microreticulation present only in traces at sides of pronotum; puncturation as that of head. 1,37 times as broad as head, moderately broader than long (width/length= 1,45) and very convex (width/height= 1,42); anterior margin weakly curved; lateral outline broadly rounded. Measurements of pronotum of holotype: length 0,93 mm, width 1,35 mm and height 0,95 mm.

Elytra: Microreticulation present only in traces; punctures as those on head, separated from each other by 10-15 times their own diameter; slightly narrower than the pronotum, little longer than broad (width/length= 0,94) and weakly convex (width/height= 1,73); lateral outline with humeral angle very broadly rounded. Measurements of elytra of holotype: length 1,32 mm, width 1,25 mm and height 0,72 mm.

Metathoracic wings absent. Meso- and metasternum: median carina sharp, lateral lines absent, femoral lines complete, rounded at middle.

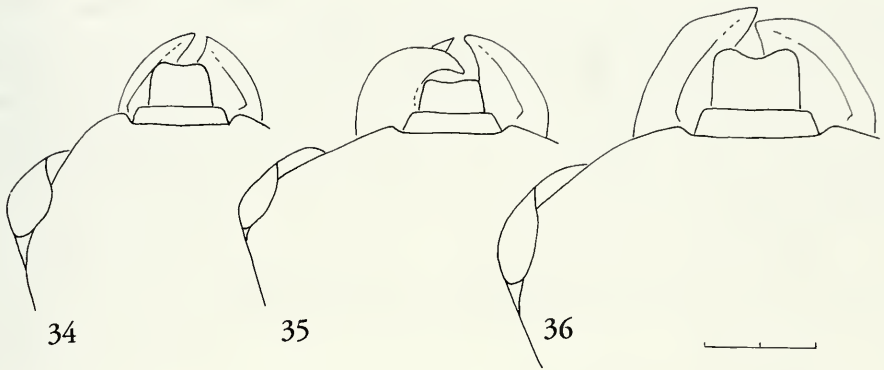

FIGS 34-36

Head of: 34, *Agathidium xilingense* sp. n.; 35, *A. kurbatovianum* sp. n.; 36, *A. megacephalum* sp. n.

Legs: Male hind femora with a sharp tooth at the posterior margin (fig.21).

Tarsal formula: ♂ 5-5-4, ♀ 5-4-4.

Aedeagus as in figures 31, 32. Spermatheca as in figure 33.

Discussion: See *Agathidium luojiense* sp. n.; from *A. huaense* Ang. & Dmz (from Shaanxi) it differs in shape of tooth of male hind femora, in shape of aedeagus, in the greater length ratio 3rd/2nd antennal segments and width ratio pronotum/head.

Distribution: China (Sichuan).

#### ***Agathidium (Microceble) xilingense* sp. n.**

Figs 22, 34, 37, 38

Holotype ♂: China, Sichuan, Mt. Xiling, 1600-2400 m, 30.VII.-4.VIII.1996, leg. S. Kurbatov, in MHNG.

Paratypes: Same data as holotype, 1 ♂ in MHNG, 1 ♂ in AC-GNHM.

Length 2,2-2,3 mm (holotype ♂ 2,3 mm). Dorsum reddish-brown; mesosternum testaceous, metasternum reddish-brown; antennae testaceous but with segments 9-10 darker; legs reddish-brown. Microreticulation almost absent, present only in traces on the pronotum and elytra; puncturation fine and sparse on whole dorsum. Sutural striae absent.

Head: Microreticulation absent; punctures small, impressed, separated from each other by 5-8 times their own diameter. Eyes hemispherical, head widest at the eyes (fig 34); antero-lateral margins distinctly raised; clypeus weakly emarginate, with a weakly impressed short groove and small pit either side. 3rd antennal segment 1,6 times longer than 2nd and as long as the 4th + 5th together.

Pronotum: Microreticulation almost absent, present only in traces; punctures larger than those of the head but more clearly impressed, separated from each other by 5-10 times their own diameter. 1,75 times as broad as head, moderately broader than long (width/length= 1,55) and moderately convex (width/height= 1,64); anterior margin

weakly curved; lateral outline broadly rounded. Measurements of pronotum of holotype: length 0,72 mm, width 1,12 mm and height 0,68 mm.

Elytra: Microreticulation almost absent, present only in traces; punctures similar to that of the pronotum but more superficial, separated from each other by 10-15 times their own diameter. Slightly narrower than the pronotum, as broad as long and moderately convex (width/height= 1,77); lateral outline with humeral angle very broadly rounded. Measurements of elytra of holotype: length 1,10 mm, width 1,10 mm and height 0,62 mm.

Metathoracic wings present. Meso- and metasternum: median carina sharp, lateral lines absent, femoral lines incomplete, rounded at middle.

Legs: Male hind femora rounded at posterior margin (fig.22). Tarsal formula: ♂ 5-5-4, ♀ unknown.

Aedeagus as in figures 37, 38.

Discussion: Species of the *andrewesi* group; *Agathidium xilingense* sp. n. is similar to *A. venustum* Ang. & Dmz (from Taiwan, Guangxi, Hong Kong, Shaanxi) and *A. taiwanense* Ang. & Dmz. (from Taiwan); it differs in greater length ratio 3rd/2nd antennal segment, the less body length and in less width ratio pronotum/head and aedeagus.

Distribution: China (Sichuan).

### **Agathidium (Macroceble) kurbatovianum** sp. n.

Figs 23, 35, 39-41

Holotype ♂: China, Sichuan, Xichang, M. Luoji, 2300-2500 m, 16.-24.VII.1996, leg. S. Kurbatov, in MHNG.

Paratypes: Same data as holotype, 3 ♀ in MHNG, 1 ♂ and 1 ♀ in AC-GNHM.

Length 2,60-2,75 mm (holotype ♂ 2,65 mm). Dorsum dark reddish-brown, venter lighter; antennae testaceous but antennal club darker; legs reddish-brown. Microreticulation absent; puncturation fine and sparse on whole dorsum. Sutural striae absent.

Head: Punctures very small, superficial, separated from each other by 2-8 times their own diameter. Widest at the eyes; eyes slightly flattened (fig. 35); antero-lateral margins uniformly raised; clypeus slightly emarginate; clypeal line absent; left mandible with a tooth. 3rd antennal segment 1,09 times as long as 2nd and shorter than 4th + 5th together.

Pronotum: Microreticulation absent; punctures smaller and more superficial than those on the head, hardly visible, separated from each other by 2-15 times their own diameter. 1,46 times as broad as head, weakly broader than long (width/length= 1,14) and very convex (width/height= 1,34); anterior margin moderately curved; lateral outline broadly rounded. Measurements of pronotum of holotype: length 1,00 mm, width 1,14 mm and height 0,85 mm.

Elytra: Puncturation as that of pronotum. As broad as pronotum, a little broader than long (width/length= 1,07) and weakly convex (width/height= 1,9); lateral outline with humeral angle very broadly rounded. Measurements of elytra of holotype: length 1,10 mm, width 1,18 mm and height 0,62 mm.



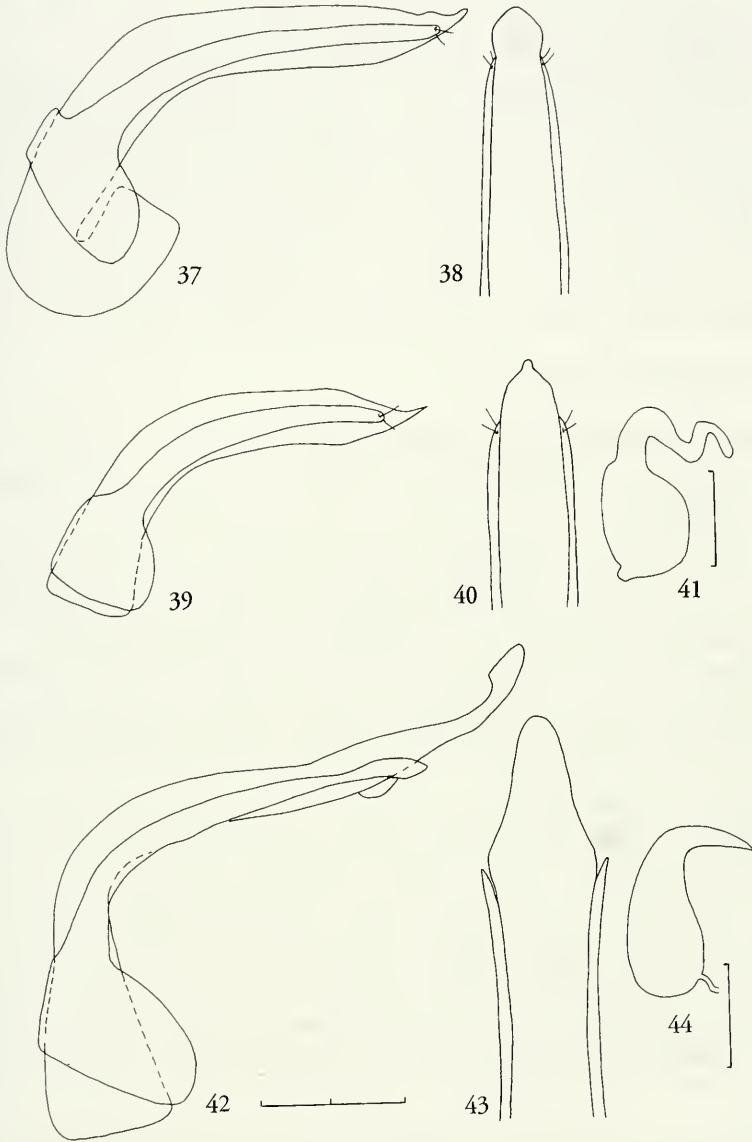

FIGS 37-44

Aedeagus (lateral and dorsal view of its apex) of: 37-38, *Agathidium xilingense* sp. n.; 39-40, *A. kurbatovianum* sp. n.; 42-43, *A. megacephalum* sp. n. — Spermatheca of: 41, *Agathidium kurbatovianum* sp. n.; 44, *A. megacephalum* sp. n.

Metathoracic wings absent. Meso- and metasternum: median carina weak, lateral lines absent, femoral lines absent, a small tubercle present between the metacoxae; metasternum short, meso- and metacoxae almost touching.

Legs: Male hind femora curved at posterior margin (fig.23). Tarsal formula: ♂ 5-5-4, ♀ 4-4-4.

Aedeagus as in figures 39, 40. Spermatheca as in figure 41.

Discussion: *Agathidium kurbatovianum* sp. n. is similar to *A. sherpa* Ang. & Dmz. (from Nepal) and *A. schawalleri* Ang. & Dmz. (from Nepal); it differs in lesser length ratio 3rd/2nd antennal segments; from *A. schawalleri* it differs also in shorter body length and in shape of the pronotum which is less transverse. From *A. oblitum* Ang. & Dmz. (from Taiwan) and *A. narusawae* Hoshina (from Ryukyus Is.) it differs in greater body length, greater width ratio pronotum/head and length ratio 3rd/2nd antennal segments. From *A. megacephalum* sp. n. (Sichuan) it differs in greater length ratio 3rd/2nd antennal segments and in shape of pronotum, less transverse and more convex.

Distribution: China (Sichuan).

**Agathidium (Macroceble) megacephalum** sp. n.

Figs 24, 36, 42-44

Holotype ♂: China, Sichuan, Xichang, M. Luoji, 2300-2500 m, 16.-24.VII.1996, leg. S. Kurbatov, in MHNG.

Paratypes: Same data as holotype, 2 ♂ and 1 ♀ in MHNG, 1 ♂ and 1 ♀ in AC-GNHM.

Length 2,7-3,0 mm (holotype ♂ 2,90 mm). Dorsum dark reddish-brown, venter lighter; antennae testaceous with club darker; legs reddish-brown. Microreticulation absent; puncturation fine and sparse on whole dorsum. Sutural striae absent.

Head: Punctures microscopic, hardly visible, separated from each other by 2-6 times their own diameter. Widest at the eyes; eyes slightly flattened (fig. 36); antero-lateral margins uniformly raised; clypeus slightly emarginate; clypeal line absent; left mandible of male with a tooth. 3rd antennal segment 0,88 times as long as 2nd and shorter than 4th + 5th together.

Pronotum: Punctures similar or smaller and more superficial than those of the head, separated from each other by 5-10 times their own diameter. 1,4 times as broad as head, slightly broader than long (width/length= 1,29) and moderately convex (width/height= 1,65); anterior margin weakly curved; lateral outline broadly rounded. Measurements of pronotum of holotype: length 1,05 mm, width 1,36 mm and height 0,82 mm.

Elytra: Punctures as those of head, separated from each other by 1-10 times their own diameter. Slightly narrower than the pronotum, as broad as long and moderately convex (width/height= 1,84); lateral outline with humeral angle very broadly rounded. Measurements of elytra of holotype: length 1,20 mm, width 1,20 mm and height 0,65 mm.

Metathoracic wings absent. Meso- and metasternum: median carina absent, lateral lines absent, femoral lines absent, a small tubercle present between the metacoxae; metasternum short, meso- and metacoxae almost touching.

Legs: Male hind femora curved at posterior margin (fig.24). Tarsal formula: ♂ 5-5-4, ♀ 4-4-4.

Aedeagus as in figures 42, 43. Spermatheca as in figure 44.

Discussion: See *Agathidium kurbatovianum* sp. n.

Distribution: China (Sichuan).

## REFERENCES

- ANGELINI, F. & DE MARZO, L. 1981. Reports of *Agathidium* from Himalaya: expeditions of Basel Natural History Museum and Prof. H. Franz (Coleoptera, Leiodidae). *Entomologica Basiliensia* 6: 187-294.
- ANGELINI, F. & DE MARZO, L. 1998. Agathidiini from China, with description of 14 new species. *Revue suisse de Zoologie* 105 (2): 351-373.
- ANGELINI, F. & SVEC, Z. 1994. Review of Chinese species of the subfamily Leiodinae. *Acta Societas Zoologica Bohemoslava* 58: 1-31.



**Considérations taxonomiques sur le genre *Hadogenes* Kraepelin, 1894: création des Hadogeninae subfam. n. et description d'une espèce nouvelle de l'Angola (Scorpiones, Scorpionidae, Hadogeninae)**

Wilson R. LOURENÇO

Laboratoire de Zoologie (Arthropodes), Muséum National d'Histoire Naturelle,  
61, rue de Buffon, F-75005 Paris, France;

e-mail: arachne@mnhn.fr

**Taxonomic considerations on the genus *Hadogenes* Kraepelin, 1894: proposition of the Hadogeninae subfam. n., and description of a new species from Angola (Scorpiones, Scorpionidae, Hadogeninae).** - The study of a new species of *Hadogenes* Kraepelin, 1894, leads to the reanalysis of the taxonomic position of this genus, with the proposition of a new subfamily Hadogeninae subfam. n. The new subfamily is placed in the family Scorpionidae, with therefore the transfer of the genus *Hadogenes* from the Ischnuridae to the Scorpionidae. The new species *Hadogenes angolensis* sp. n. is described from Angola.

**Key-words:** Scorpionidae - Hadogeninae - *Hadogenes* - taxonomy - Angola.

INTRODUCTION

Le genre *Hadogenes* a été établi par KRAEPELIN (1894) ayant comme espèce-type *Scorpio (Ischnurus) trichiurus* Gervais, 1843 [= *Hadogenes trichiurus* (Gervais 1843)]. KRAEPELIN place ce genre dans la famille des Scorpionidae et dans la sous-famille des «Ischnurini». Cette classification a été maintenue par KRAEPELIN (1899) dans sa monographie «Das Tierreich» et dans son analyse phylogénétique et biogéographique des scorpions publiée en 1905. BIRULA (1917) propose une «tribu» Ischnuraria avec les sous-familles Ischnurinae, Hormurinae, Hemiscorpiinae et Heteroscorpioninae, avec le genre *Hadogenes* toujours placé dans la sous-famille des Ischnurinae. Tous les auteurs subséquents (e.g. HEWITT 1918; LAWRENCE 1955; LAMORAL 1979; LAMORAL & REYNDERS 1975) suivent cette classification.

Lors de ma révision des genres appartenant aux Ischnurinae, désormais élevée au rang de famille des Ischnuridae (LOURENÇO 1985, 1989), un certain nombre de décisions n'ont pu être prises de manière satisfaisante. Ainsi, les statuts des genres *Chiromachetes* Pocock, 1899 et *Hormiops* Fage, 1933, considérés comme douteux, position d'ailleurs suivie par SISSOM (1990), ont été révisés et revalidés à l'appui de nouvelles données (LOURENÇO 1997; LOURENÇO & MONOD 1999). Le genre *Hadogenes* a reçu peu d'attention, et est resté placé chez les Ischnuridae. Il est suggéré seulement

une certaine affinité entre *Hadogenes* et *Heteroscorpion* Birula, 1903, endémique de Madagascar, pour lequel déjà KRAEPELIN (1905) avait proposé une sous-famille *Heteroscorpioninae*. Des études approfondies sur la faune des scorpions de Madagascar (LOURENÇO 1996) ont permis une réanalyse précise de la position du genre *Heteroscorpion*, avec élévation de cette sous-famille au rang de famille (*Heteroscorpionidae*).

## TAXONOMIE

### RÉANALYSE DU STATUT TAXONOMIQUE DU GENRE *HADOGENES* AVEC PROPOSITION D'UNE NOUVELLE SOUS-FAMILLE

Dans son travail sur les scorpions de la Namibie, LAMORAL (1979) dresse une liste des caractères différentiels entre le genre *Hadogenes* et les autres genres appartenant aux *Ischnuridae*, en particulier ceux tirés de la structure des hémispermatothorax et du modèle trichobothriotaxique, caractères globalement négligés par les auteurs précédents déjà cités. Ces caractères sont réanalysés lors de l'étude réalisée par LOURENÇO (1985, 1989), sans pour autant aboutir à une décision sur la position systématique des *Hadogenes*.

À présent, un ensemble de caractères m'amène à proposer une nouvelle sous-famille monotypique avec genre-type *Hadogenes*. Cette sous-famille est placée, par prudence, au sein de la famille des *Scorpionidae*.

### **Hadogeninae** subfam. n.

*Diagnose*: Scorpion de grande taille (10 à 20 cm). Prosoma et mesosoma très aplatis dorso-ventralement. Hémispermatothorax armé d'un crochet à double apex (Figs 16 à 18); les genres d'*Ischnuridae* et de *Scorpionidae* présentent, sans exception, des hémispermatothorax armés d'un crochet avec un seul apex. Yeux médians situés au centre de la carapace, plus proches de l'arrière que de l'avant; enfouis avec un tubercule oculaire obsolete. Trichobothriotaxie du type C, néobothriotaxique majorante, pléthotaxique (Vachon, 1973) (Figs 11 à 15). La pléthotaxie est absente chez les genres d'*Ischnuridae*, mais présente chez certains genres de *Scorpionidae* tels *Pandinus* Thorell. Glandes à venin des types lisse, pré-lobé ou semi-lobé (Figs 23 et 24), alors que les genres d'*Ischnuridae* présentent généralement la structure lisse et ceux des *Scorpionidae* la structure lobée.

### DESCRIPTION D'UNE NOUVELLE ESPÈCE

LAMORAL (1979) signale que le genre *Hadogenes* doit faire l'objet d'un travail de révision. Il se contente cependant de caractériser les trois espèces jugées valides présentes en Namibie. Déjà HEWITT (1918), dans sa monographie sur les scorpions de l'Afrique du Sud, fait une remarque semblable à propos du genre, et soulève les difficultés de classification des espèces, en grande partie en raison d'une certaine «variabilité» des caractères étudiés. Cette situation amène la description de variétés pas toujours satisfaisantes. Il est vrai que les auteurs anciens ont utilisé dans leur études des

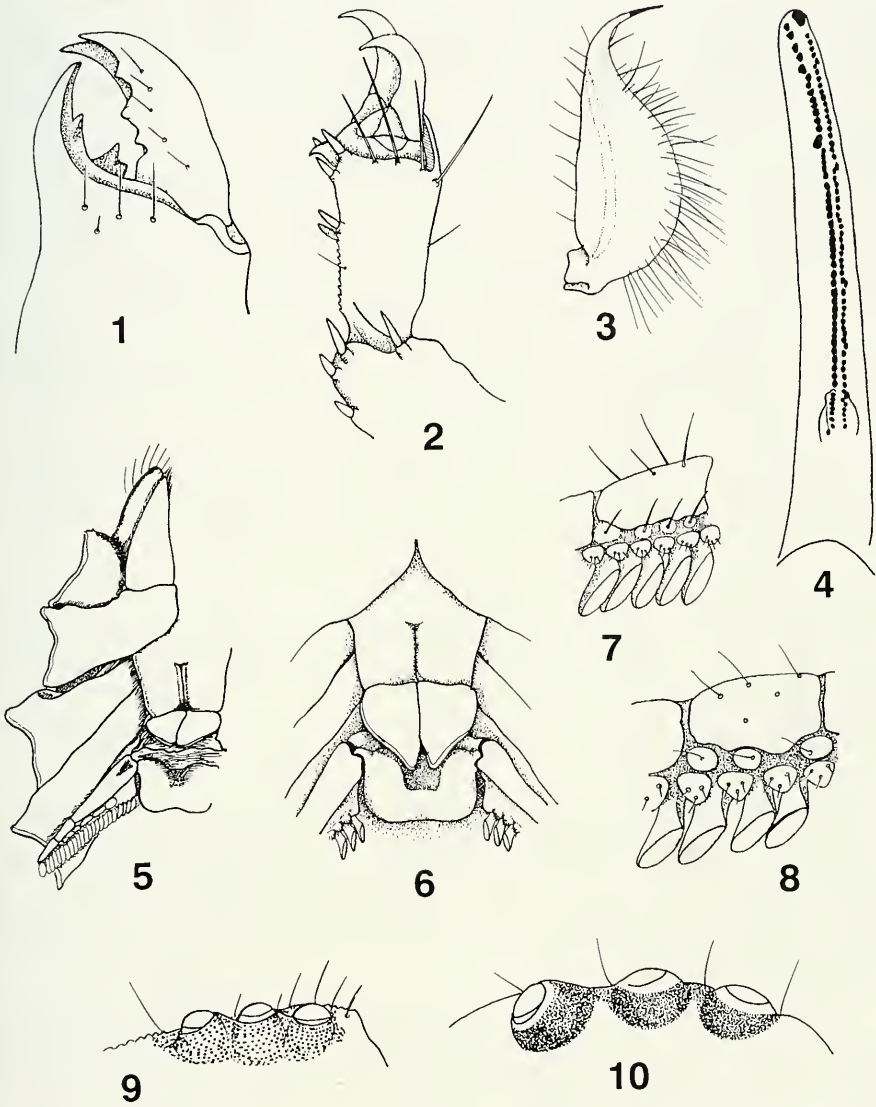

FIGS 1 à 10

*Hadogenes angolensis* sp. n. 1. Chélicère (mâle). 2. Tarse, vue latérale (mâle). 3. Telson (mâle). 4. Tranchant du doigt mobile (mâle). 5. Hanche, sternum, opercule génital et peigne (mâle). 6. Sternum, opercule génital et base des peignes (femelle). 7 et 8. Région proximale des peignes chez le mâle et la femelle. 9 et 10. Yeux latéraux chez le mâle et la femelle.

caractères tirés exclusivement de la morphologie externe, en négligeant la structure des hémispermatothores qui joue actuellement un rôle majeur dans la systématique du genre *Hadogenes*, ainsi que dans celle des genres d'Ischnuridae et de Scorpionidae.

Le genre *Hadogenes* est réparti sur une grande partie du sud de l'Afrique, plus précisément, en Angola, Botswana, Congo (?), Mozambique, Namibie, Afrique du Sud et Zimbabwe. Sa présence en Angola est limitée à une seule citation de LAWRENCE (1959), qui signale *Hadogenes taeniurus* (Thorell) dans ce pays (Vila Arriaga près de Lungo: aujourd'hui Lubango, et Lucira). NEWLANDS (1972), LAMORAL (1979) et LAMORAL & REYNDERS (1975) mentionnent à nouveau *Hadogenes taeniurus* pour la partie sud du pays, sans pour autant préciser avoir examiné le matériel en question.

La faune des scorpions d'Angola a été jusqu'à présent très peu connue. Les publications se limitent à celles de MONARD (1929, 1937), suivies de LAWRENCE (1949, 1959, 1961) et VACHON (1950). Seul LAWRENCE (1959) mentionne le genre *Hadogenes*, mais il m'a été impossible de localiser le matériel en question.

L'étude de trois spécimens collectés dans la région du Plateau de l'Huila, près de Capangombe, permet la description d'une nouvelle espèce, qui présente des similitudes avec *H. taeniurus*. Ceci soulève la question d'une possible erreur d'identification de la part de LAWRENCE (1959), non vérifiée par LAMORAL (1979).

### ***Hadogenes angolensis* sp. n.**

Figs 1 à 17, 19 et 20, 23

*Matériel-type.* Holotype mâle. Angola, Région de l'Huila, «Fazenda Bumbo» près de Capangombe (15°10'S - 13°09'E). 21-26/VI/1954 (W. Kisker & H. Barmann leg.). Une femelle allotype et un mâle (juvenile) paratype, mêmes données que pour l'holotype. Muséum d'histoire naturelle, Genève.

*Etymologie.* Le nom spécifique fait référence au pays où la nouvelle espèce a été collectée.

*Diagnose.* *Hadogenes angolensis* sp. n. peut être distingué des autres espèces du genre, et en particulier d'*H. taeniurus* (Thorell), par des différences dans la structure du VIIème sternite (Figs 19 à 22) et dans celle des hémispermatothores, en particulier celle de la lame distale (Figs 16 à 18), et par un nombre plus élevé de dents aux peignes, 22/23 et 15/16 chez les mâles et femelles de *H. angolensis* contre 17/19 et 13/15 chez *H. taeniurus*.

*Description fondée sur l'holotype mâle.* Mensurations (en mm) dans le tableau I.

*Coloration.* La couleur de base est jaune-rougeâtre. Prosoma: plaque prosomienne de couleur rouge-jaunâtre avec des zones latéro-médianes plus foncées, rougeâtres. Tubercule oculaire et zones des yeux latéraux plus foncées, allant vers le noirâtre. Mesosoma de même couleur que la plaque prosomienne, mais plus uniformément jaunâtre, avec des zones rougeâtres peu marquées. Metasoma avec les cinq anneaux de couleur jaune-rougeâtre, avec quelques taches brunâtres, très estompées. Vésicule jaunâtre avec quelques zones brunâtres estompées; l'aiguillon rougeâtre. Ster-

Figs 11 à 15

*Hadogenes angolensis* sp. n. Trichobothriotaxie du type C. néobothriotaxie majorante plethotaxique (holotype mâle). 11 à 13. Pince, vues dorsale, externe et ventralo-externe. 14 et 15. Tibia, vues dorsale et ventrale.



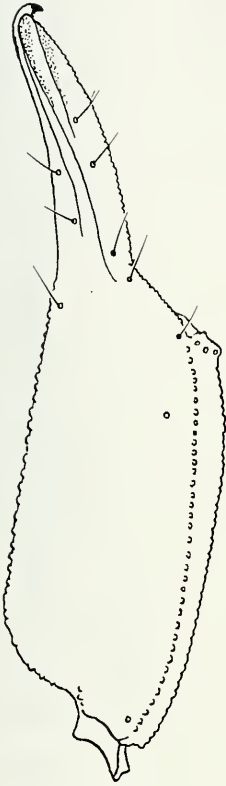

11

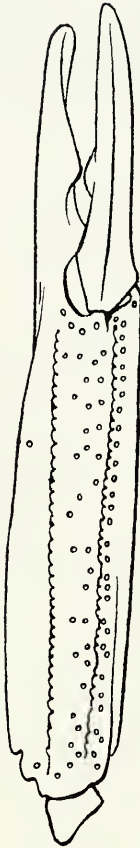

12

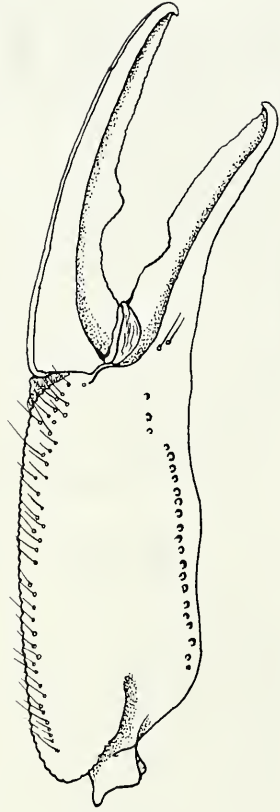

13

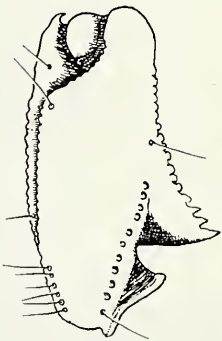

14

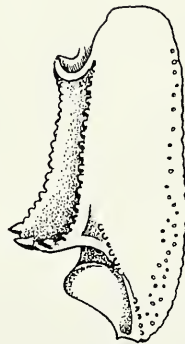

15

nites jaunâtre foncé; le VIIème légèrement plus foncé postérieurement. Peignes et opercule génital jaunâtre foncé; sternum, hanches et processus maxillaires presque entièrement rougeâtres. Pattes jaunâtres avec des zones rougeâtres sur les articulations et sur les carènes internes. Pédipalpes jaune-rougeâtre; carènes internes et doigts noirs. Chélicères jaune-rougeâtre avec absence de toute trame plus foncée; doigts rougeâtres.

Morphologie. Front de la plaque prosomienne légèrement échancré. Tubercule oculaire presque au centre de la plaque prosomienne, mais légèrement en arrière de 0,6 mm; yeux médians séparés par plus d'un diamètre oculaire. Trois yeux latéraux (Fig. 9). Sillon interoculaire peu profond, s'allongeant jusqu'à l'arrière des yeux médians où il se divise en deux, devenant très estompé, et entoure une fossette triangulaire. Toute la plaque prosomienne est couverte de granulations très fines. Les sillons et la fossette triangulaire sont dépourvus de granulations. Mesosoma: tergites couverts d'une très fine granulation, moins marquée dans leur région postérieure. Carène axiale pratiquement absente. Metasoma à anneaux très aplatis latéralement, en particulier les anneaux II à V; toutes les carènes sont très peu marquées à l'exception des dorsales sur les anneaux II à V. Anneaux II à V à face ventrale pourvue de granules spiniformes, bien plus marqués sur le Vème. Telson en forme de poire avec la vésicule dépourvue de carènes; aiguillon proportionnellement très court; présence d'une importante chetotaxie sur la vésicule (Fig. 3). Peignes avec 23-22 dents (Fig. 5). Sternites lisses, à grands stigmates linéaires. Opercule génital fait de deux plaques semi-ovales (Fig. 5). Pédipalpes: fémur à 5 carènes pourvues de granules très gros; tégument intercarénal avec des granules fins. Tibia et pince avec quatre carènes complètes formées par des gros granules. Présence sur la face interne du tibia d'un éperon très développé dans la région basale, avec deux granules majeurs à l'extrémité (Figs 14 et 15). Pince grande et aplatie; main bien plus longue que les doigts (Figs 11 à 13); face dorsale pourvue de granulations plutôt fines; faces latérales avec des granulations moyennes; face ventrale brillante et presque réticulée. Doigts lisses; granulations du tranchant des doigts se disposant en deux lignes longitudinales (Fig. 4); granules accessoires absents; présence d'un mamelon sur le doigt mobile. Pattes: dernier article tarsal avec six épines plus importantes disposées en trois séries. Chélicères avec la dentition caractéristique de la famille des Scorpionidae (Fig. 1; Vachon, 1963). Trichobothriotaxie du type C, néobothriotaxique majorante, plethotaxique (Figs 11 à 15; VACHON 1973). Hémispermatophores: les figures 16 et 17 montrent l'hémispermatophore en vue d'ensemble, faces interne et externe, avec des détails de la région médiane, où les différentes parties sont illustrées, en particulier le crochet à double apex. Glande à venin du type simple (Fig. 23).

#### FIGS 16 à 24

16 à 18. Hémispermatophores. 16 et 17. *Hadogenes angolensis* sp. n., vue externe et interne. 18. *Hadogenes taeniurus*, vue interne (redessiné d'après LAMORAL 1979). – 19 à 22. Structure du VIIème sternite. 19 et 20. *Hadogenes angolensis* sp. n., mâle et femelle. 21 et 22. *Hadogenes taeniurus*, mâle et femelle (redessiné d'après Lamoral 1979). – 23 et 24. Structures des glandes à venin chez le genre *Hadogenes*. 23. *H. angolensis* sp. n. (simple). 24. *H. gracilis* (semi-lobée).

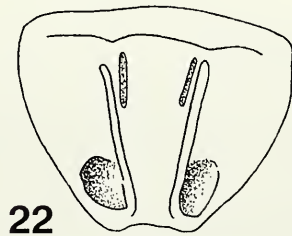
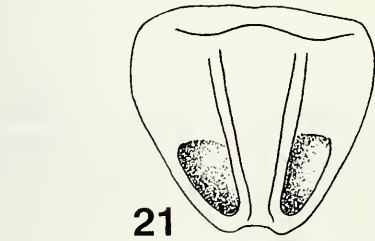
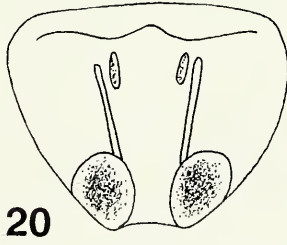
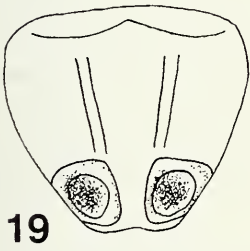
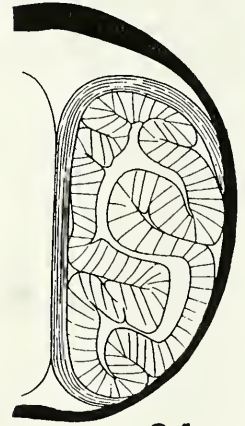
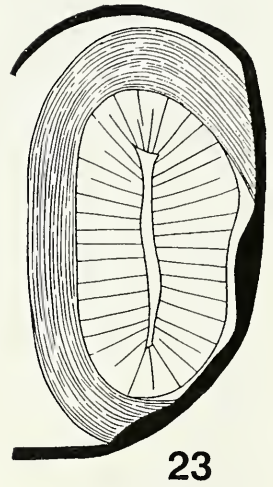
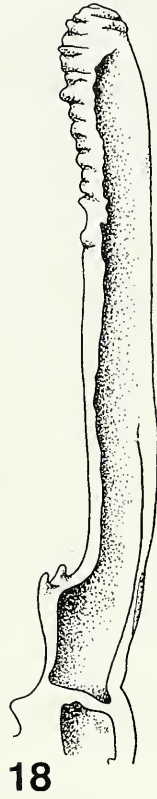
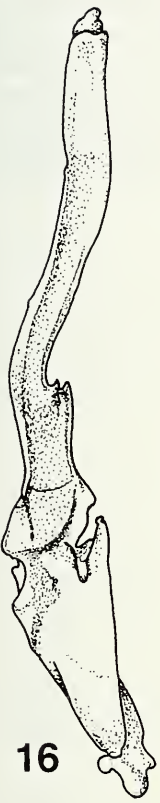

*Femelle*. Coloration semblable à celle du mâle, avec les tergites plus clairs et les anneaux du metasoma davantage rougeâtres. Corps globalement plus trapue. Pédipalpes plus robustes, anneaux du metasoma nettement plus courts et moins aplatis latéralement (cf. Tableau I). Yeux latéraux disposés plus en courbe que ceux du mâle (Fig. 10). Opércule génital couvert par une plaque unique de forme pentagonale, fendue à l'extrémité (Fig. 6). Peignes plus petits avec 16-15 dents (Fig. 6). Mâle juvenile (paratype), avec 22-22 dents aux peignes.

TABLEAU I

Mensurations (en mm) de l'holotype mâle et de l'allotype femelle d'*Hadogenes angolensis* sp. n.

	Mâle	Femelle
Prosoma		
- Longueur	16,2	17,4
- Largeur antérieure	9,4	10,5
- Largeur postérieure	16,9	18,4
Anneau caudal I		
- Longueur	10,0	7,7
- Largeur	3,7	3,6
Anneau caudal V		
- Longueur	15,4	12,5
- Largeur	2,2	2,3
- Hauteur	3,4	3,2
Vésicule		
- Largeur	2,8	2,8
- Hauteur	3,6	3,7
Pédipalpe		
- Fémur longueur	16,1	16,2
- Fémur largeur	5,8	6,5
- Tibia longueur	15,1	16,5
- Tibia largeur	5,9	6,4
- Pince longueur	29,9	31,9
- Pince largeur	9,8	11,2
- Pince hauteur	4,4	5,6
Doigt mobile		
- Longueur	12,4	14,7

## REMERCIEMENTS

Je suis très reconnaissant à Philippe Bouchard et Maurice Gaillard, Muséum National d'Histoire Naturelle, Paris pour leur contribution à la réalisation des dessins illustrant le présent travail, aux Drs Jacqueline Kovoov et Sabine Jourdan (Paris) pour la lecture du manuscrit et au Dr A. de Barros Machado (Oeiras) pour m'avoir fourni des renseignements sur les spécimens décrits.

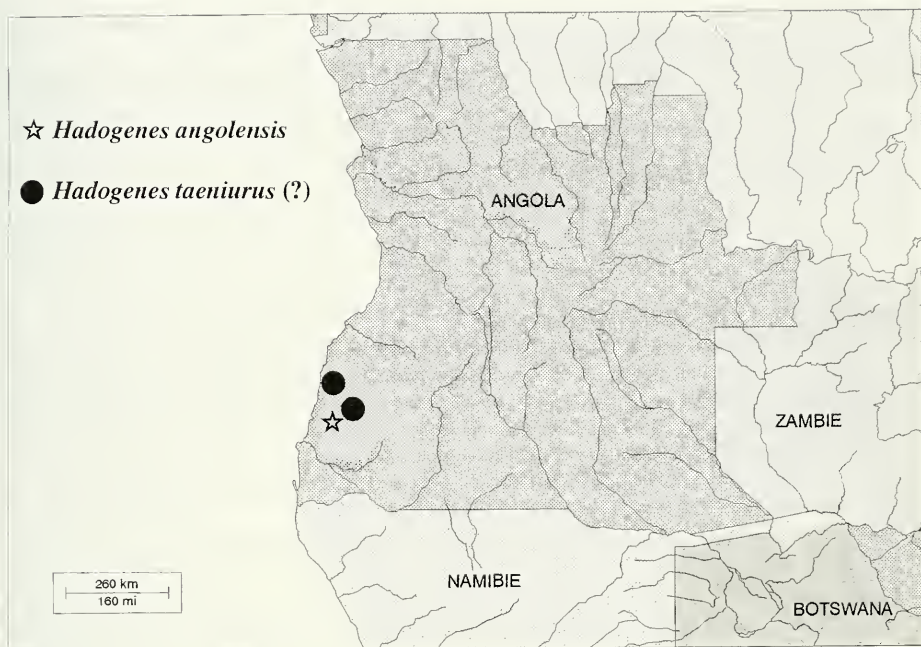

FIG. 25

Carte avec indication de la localité-type d'*Hadogenes angolensis* sp. n. et les stations citées pour *Hadogenes taeniurus* par LAWRENCE (1959).

## BIBLIOGRAPHIE

- BIRULA, A. 1917. Arthogastric Arachnids of Caucasia. Part I. Scorpiones. *Mémoires du Muséum du Caucase, sér. A*, 5 : 253 pp. (English translation : Israel Program for Scientific Translations, Jerusalem, 1964 : 170 pp.).
- HEWITT, J. 1918. A survey of the scorpion fauna of South Africa. *Transactions of the Royal Society of South Africa* 6 : 89-192.
- KRAEPELIN, K. 1894. Revision der Scorpione. II. Scorpionidae und Bothriuridae. *Jahrbuch der Hamburgischen Wissenschaftlichen Anstalten* 11 : 1-248.
- KRAEPELIN, K. 1899. Scorpiones und Pedipalpi. *Iu: Das Tierreich*, 8 : 1-265. *Friedländer Verlag, Berlin*.
- KRAEPELIN, K. 1905. Die Geographische Verbreitung der Scorpione. *Zoologische Jahrbücher, Abteilung Systematik* 22 : 321-364.
- LAMORAL, B. H. 1979. The scorpions of Namibia (Arachnida : Scorpionida). *Annals of the Natal Museum* 23 (3) : 497-784.
- LAMORAL, B. H. & REYNDERS, S. 1975. A catalogue of the scorpions described from the Ethiopian Faunal region. *Annals of the Natal Museum* 22 (2) : 489-576.
- LAWRENCE, R. F. 1949. A collection of Opiliones and Scorpions from North-East Angola made by Dr. A. de Barros Machado in 1948. *Publicações Culturais da Companhia de Diamantes de Angola*: 1-20.
- LAWRENCE, R. F. 1955. Solifugae, Scorpions and Pedipalpi. with check-lists and keys to South African families, genera and species. *South African Animal Life* 1 : 152-262.

- LAWRENCE, R. F. 1959. A collection of Arachnida and Myriapoda from the Transvaal Museum. *Annals of the Transvaal Museum* 23 : 363-386.
- LAWRENCE, R. F. 1961. New Scorpions and Solifugae from S.W.A. and Angola. *Kungl. Fysio-grafiska Sällskapet i Lund Forhandlingar* 31 (15) : 147-160.
- LOURENÇO, W. R. 1985. Essai d'interprétation de la distribution du genre *Opisthacanthus* (Arachnida, Scorpiones, Ischnuridae) dans les régions Néotropicale et Afrotropicale. Etude taxinomique, biogéographique, évolutive et écologique. *Thèse de Doctorat d'Etat, Université Pierre et Marie Curie*, 287 pp.
- LOURENÇO, W. R. 1989. Rétablissement de la famille des Ischnuridae, distincte des Scorpionidae Pocock, 1893 à partir de la sous-famille des Ischnurinae Pocock, 1893. *Revue Arachnologique* 8 (10) : 159-177.
- LOURENÇO, W. R. 1996. Scorpions. *Faune de Madagascar, M.N.H.N.*, 87 : 1-102.
- LOURENÇO, W. R. 1997. Considérations taxonomiques sur le genre *Chiromachetes* Pocock, 1899 (Chelicerata, Scorpiones, Ischnuridae). *Zoosystema* 19 (1) : 81-89.
- LOURENÇO, W. R. & MONOD, L. 1999. Confirmation de la validité du genre *Horniops* Fage, 1933 avec redescription d'*Hormiops davidovi* Fage, 1933 (Scorpiones, Ischnuridae). *Zoosystema* 21 (2): 337-344.
- MONARD, A. 1929. Matériaux de la mission scientifique suisse en Angola. Scorpions. *Bulletin de la Société neuchâteloise de Sciences naturelles* 54 : 37-43.
- MONARD, A. 1937. Scorpions, Solifuges et Opilions d'Angola. *Revue suisse de Zoologie* 44 (13) : 251-258.
- NEWLANDS, G. 1972. A description of *Hadogenes lawrencei* sp. nov. (Scorpiones) with a checklist and key to the South West African species of the genus *Hadogenes*. *Madoqua, ser. 2*, 1 (54-62) : 133-140.
- SISSOM, W. D. 1990. Systematics, Biogeography, and Paleontology. In: POLIS, G.A. (ed.). *The Biology of Scorpions*. Stanford University Press, Stanford, pp. 64-160.
- VACHON, M. 1950. Remarques sur les Scorpions de l'Angola. *Publicações Culturais da Companhia de Diamantes de Angola*: 1-18.
- VACHON, M. 1963. De l'utilité, en systématique, d'une nomenclature des dents des chélicères chez les Scorpions. *Bulletin du Muséum national d'Histoire naturelle, Paris, 2e sér.*, 35 (2) : 161-166.
- VACHON, M. 1973. Etude des caractères utilisés pour classer les familles et les genres de Scorpions (Arachnides). 1. La trichobothriotaxie en arachnologie. Sigles trichobothriaux et types de trichobothriotaxie chez les Scorpions. *Bulletin du Muséum National d'Histoire Naturelle, Paris, 3e sér.*, n° 140, Zool. 104: 857-958.

## Studies on tiger beetles. XCVIII. A new *Cylindera* from Chubut, Argentina (Coleoptera: Cicindelidae)

Fabio CASSOLA

Via F. Tomassucci 12/20, I-00144 Roma, Italy.

**Studies on tiger beetles. XCVIII. A new *Cylindera* from Chubut, Argentina (Coleoptera: Cicindelidae).** - A new tiger beetle species, *Cylindera* (*Plectographa*) *chubuti* sp. n., closely related to *C. (P.) gormazi* (Reed, 1871), is described and figured, based on four specimens collected at El Maidén, Chubut, Argentina.

**Key-words:** Tiger beetles - Cicindelidae - *Cylindera* - new species - Argentina.

### INTRODUCTION

The tiger beetle fauna of Argentina is probably still uncompletely known. A checklist had been presented long ago by BRUCH (1911), who listed 42 species in all, while additional information was later given in general catalogues of the family such as those by HORN (1905, 1908-15, 1926), BLACKWELDER (1944), and WIESNER (1992). Afterwards, a single new species was described by MANDL (1963), and VIDAL SARMIENTO (1965) mentioned the occurrence of a *Ctenostoma* species in the northern part of Argentina. Later, VIDAL SARMIENTO (1966) recognized the occurrence of 19 species belonging to the genus *Cicindela* s. l. in Argentina, while SUMLIN (1979) subsequently described four additional new species and raised up to 27 the *Cicindela* s. l. species known from the country. The same author (SUMLIN 1993) added later one more new species and, by adding also a previously overlooked species, he brought up to 29 the known number of the Argentine species of subtribe Cicindelina (sensu RIVALIER 1971). Finally, SUMLIN (1994) has recorded from Argentina one *Iresia* species as well. Present-day knowledge has been summarized by CASSOLA & PEARSON (2000), who recorded for Argentina a total of 65 species, 13 of which endemic of the country.

Several years ago, among other tiger beetle material of the Muséum d'histoire naturelle of Geneva (Switzerland), which was kindly submitted for identification by Dr. Ivan Löbl, I found four specimens of a remarkable *Cylindera* species of the subgenus *Plectographa* Rivalier, 1954, which appeared to be new to science. This species (from Chubut, northern Patagonia) was obviously a near relative of *C. (P.) gormazi* (Reed, 1871), but it showed unusual elytral markings which made it to be easily distinguishable from any other known related species. However, so far I have refrained

myself from describing the new species because a form of *C. (P.) gormazi* (Reed, 1871) from Chile, having enlarged partially confluent elytral markings, had been described by VARAS ARANGUA (1921) as "*Izquierdoi* n. var.", and it was not clear from his description whether my specimens could well be the same form. Moreover, two additional names (*Cicindela vidali* Philippi & Juliet, 1871, and *Cicindela gormazi* var. *dolorosa* W. Horn, 1896, both described from Chile) are available in the entomological literature which appear to belong to *C. (P.) gormazi* (VARAS ARANGUA 1921, HORN 1926, WIESNER 1992). Therefore, to not take the risk of creating a useless junior synonym, I felt it better to wait for additional material and information.

Luckily enough, thanks to the courtesy of Dr. Lothar Zerche of the Deutsches Entomologisches Institut (DEI) of Eberswalde, Germany, I was recently able to borrow two interesting female specimens (labelled respectively "Santiago/ de Chile/ Dr. Puelma" and "Chile/ ex cab/ Brown") which appear to be *izquierdoi*. As to *vidali*, it is just a junior synonym of *gormazi*, as PHILIPPI himself did recognize (PHILIPPI 1887, VARAS ARANGUA 1921), while the original description of *dolorosa* alone makes it clear that this name applies to a *gormazi* population having unusually narrow elytral markings (HORN 1896, VARAS ARANGUA 1921). Thus, my last doubts about the status of the Chubut species can be finally set aside, and therefore I give below its description.

***Cylindera (Plectographa) chubuti* sp. n.**

Fig. 1a-b

*Material examined*: Male holotype and three male paratypes from ARGENTINA (Chubut), El Maitén, 8 February 1966. A. Kovacs leg.; holotype and one paratype in the collection of the Muséum d'histoire naturelle (Geneva, Switzerland), two paratypes in author's collection. The type-locality lies in northern Chubut, along the eastern base of the Andes Mountains, just near the border with Rio Negro.

*Diagnosis*. A small black *Cylindera* species of the subgenus *Plectographa*, closely allied to *C. (P.) gormazi* (Reed, 1871) (Fig. 1c-d), however easily distinguished from it by the different elytral markings. Female unknown.

*Description*. Head dull black with some slight metallic bluish-green to violet reflections on vertex and eyes; front, clypeus and cheeks rather strongly pilose, with many sparse, white, semi-erect hairs; some sparse, fine, erect long hairs on vertex too. Eyes dark yellowish, relatively small. Labrum testaceous (narrowly darkened on margins), short, transverse, feebly unidentate in the middle, with 10-11 white short hairs or setigerous punctures near forward edge. Mandibles relatively short, externally testaceous from base to middle, shining black with greenish reflections internally and in apical half. Maxillary palpi metallic dark to green, the basal joint with long white hairs especially on the outer side; labial palpi testaceous with the last joint metallic green. Antennae relatively short and thick, reaching approximately the first third of the elytral length in male (expectedly shorter in female); articles 1-4 metallic dark green to violet, nearly glabrous, a single seta or setigerous puncture on tip of scape; joints 5-11 equally long, dull brownish-black, finely and evenly pubescent.

Thorax: pronotum obviously wider than long, sub-rectangular shaped, dull black with metallic bluish-green reflections in transversal grooves, sparsely pubescent



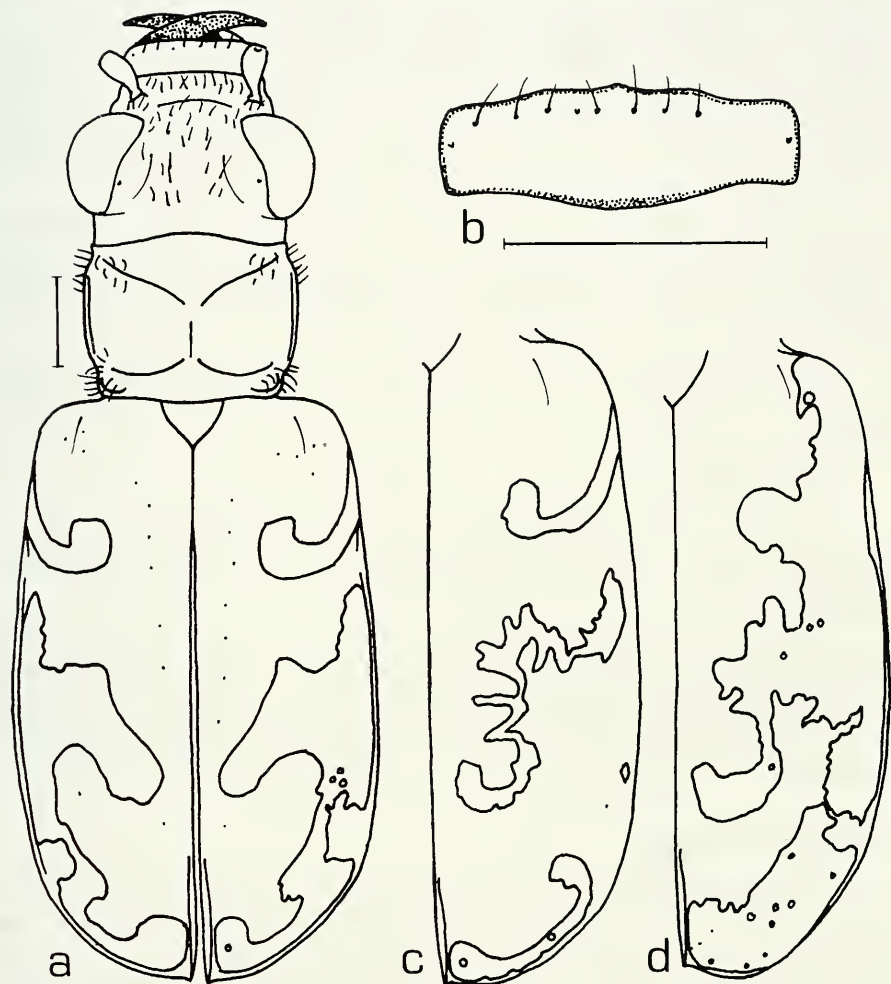

FIG. 1

*Cylindera (Plectographa) chubuti* sp. n., male paratype: a, habitus; b, labrum. *C. (P.) gormazi* (Reed, 1871), male specimen from "Llanquihue, Chile": c, right elytron. *C. (P.) gormazi*, female specimen from "Santiago de Chile" (m. *izquierdoi* Varas Arangua, 1871): d, right elytron. Scale lines: 1 mm.

at sides, a few hairs also sparsely on disc (expectedly often rubbed-off in old specimens). Episterna metallic greenish-black with some cupric reflections at base near the coxae, sparsely covered with long erect white hairs.

Elytra relatively large, together much wider than head with eyes, slightly rounded at sides, dull brownish-black with some greenish reflections on shoulders; a few poorly apparent green punctures near the shoulders and in a irregular longitudinal row parallel to, but some distance from, the suture; lateral margins and base of elytra

shining metallic green to violet. Hind margins evenly rounded, non-microserrated, sutural angle right with a very small apical tooth. Elytral markings yellowish-white, conspicuous, constituted by a long complete humeral lunule, a large wide middle band (widely expanded along the lateral border and obliquely crossing the elytral disc until a short distance from the suture), and a short complete apical lunule, whose subapical dot is narrowly connected on disc with the hind margin of the middle band. Epipleura metallic greenish-bronze, more or less rufescent in apical half.

Underside metallic dark bronze with green to bluish metallic reflections, strongly covered with white long hairs on sternal pieces and coxae, as well as in the outer third of the abdominal sternites; trochanters dark blackish-brown. Legs metallic green with some cupric to violet reflections; a few rows of white spiniform hairs on femora and tibiae, tarsal claws rufescent apically.

Male aedeagus similar to that of *C. (P.) gormazi* (VIDAL SARMIENTO 1966), short, bulky, arc-shaped, with a short blunt protruding apex followed by a conspicuous lateral crest on both sides.

Female unknown.

Length: 9.3-9.5 mm (without labrum).

*Etymology.* This small new *Plectographa* species is named from the geographical region where it comes from, the province of Chubut in northern Argentinian Patagonia.

*Remarks.* *C. (P.) gormazi* and *C. (P.) chiliensis* (Audouin & Brullé, 1839) - both described from Chile (REED 1871, AUDOUIN & BRULLÉ 1839, PEÑA & BARRIA 1973) - have also been recorded from Chubut (BRUCH 1911, SUMLIN 1979), but unfortunately no precise locality data are available. However, the apparent overlapping of ranges seems to strengthen the concept of *C. (P.) chubuti* sp. n. as specifically distinct.

## AKNOWLEDGMENTS

I would wish to thank Dr. Ivan Löbl (Muséum d'histoire naturelle, Geneva, Switzerland) for having submitted for identification many tiger beetle materials. Best thanks are also to be given to Dr. Lothar Zerche (DEI, Eberswalde, Germany), who kindly allowed me to borrow and study several specimens from Walther Horn's important collection.

## LITERATURE CITED

- AUDOUIN, J. V. & BRULLÉ, A. 1839. Descriptions des espèces nouvelles ou peu connues de la famille des Cicindélètes, faisant partie de la collection du Muséum. *Archives du Muséum d'Histoire naturelle, Paris* 1: 115-142, 3 pls.
- BLACKWELDER, R. E. 1944. Checklist of the Coleopterous Insects of Mexico, Central America, the West Indies, and South America. Part I. *Bulletin of the United States national Museum*, No. 185: 1-188.
- BRUCH, C. 1911. Catálogo sistemático de los Coleópteros de la República Argentina. Pars I. Familia Carabidae (Cicindelinae, Carabinae). *Revista del Museo de la Plata* 17 (2, 4): 143-180.

- CASSOLA F. & PEARSON, D. L. 2000. Global patterns of tiger beetle species richness (Coleoptera: Cicindelidae): Their use in conservation planning. *Biological Conservation* 92 (in press).
- HORN, W. 1896. Die Cicindeliden der Dohrn'schen Sammlung. *Stettiner entomologische Zeitung* 57: 164-177.
- HORN, W. 1905. Systematischer Index der Cicindeliden. *Deutsches entomologische Zeitschrift, Beiheft*: 1-56.
- HORN, W. 1908-15. Coleoptera, Fam. Carabidae, Subfam. Cicindelinae. In: WYTSMAN P. (ed.). *Genera Insectorum*. 82A/C: 1-487, pl. 1-23.
- HORN, W. 1926. Carabidae: Cicindelinae. In: JUNK, W. (ed.). *Coleopterorum Catalogus*, Pars 86. *Berlin*, 345 pp.
- MANDL, K. 1963. Über neue Cicindeliden-Aufsammlungen aus tropischen Ländern (Col.). *Entomologischen Arbeiten aus dem Museum G. Frey, Tübingen* 14 (2): 575-592, pl. I-II.
- PEÑA, L. E. & BARRIA P., G. 1973. Revisión de la Familia Cicindelidae (Coleoptera), en Chile. *Revista chilena de Entomología* 7: 183-191.
- PHILIPPI, F. 1887. Catálogo de los Coleópteros de Chile. *Anales de la Universidad de Chile* 71: 619-806.
- REED, E. C. 1871. Notes on some Chilean *Cicindelae*, with description of a new species. *Entomologist's Monthly Magazine* 8: 76-77.
- RIVALIER, É. 1954. Démembrement du genre *Cicindela* Linné. II. Faune américaine. *Revue française d'Entomologie* 21: 249-268.
- RIVALIER, É. 1971. Remarques sur la tribu des Cicindelini (Col. Cicindelidae) et sa subdivision en sous-tribus. *Nouvelle Revue d'Entomologie* 1: 135-143.
- SUMLIN, W. D. 1979. A brief review of the genus *Cicindela* of Argentina (Coleoptera: Cicindelidae). *Journal of the New York entomological Society* 87 (2): 98-117.
- SUMLIN, W. D. 1993. Studies on the Neotropical Cicindelidae IV: Notes on Argentine *Cicindela* with the description of a new species (Coleoptera). *Cicindela* 25 (3/4): 29-39.
- SUMLIN, W. D. 1994. Studies on the Neotropical Cicindelidae V: A review of the genus *Iresia* (Coleoptera). *Cicindelidae: Bulletin of worldwide Research* 3 (1): 1-32.
- VARAS ARANGUA, E. 1921. Contribución al estudio de los Cicindelidae. Los Cicindelidae de Chile. *Revista chilena de Historia natural pura y aplicada* 25: 28-61.
- VIDAL SARMIENTO, J. 1965. Genero *Ctenostoma* Klug nuevo para la Argentina (Coleoptera, Cicindelidae). *Revista de la Sociedad entomológica argentina* 27 (1-4): 29-32.
- VIDAL SARMIENTO, J. 1966. Las especies argentinas de los generos *Cicindelidia* Riv., *Brasiella* Riv. y *Cylindera* Westwood. Estudio de las estructuras genitales del macho. *Revista del Museo de la Plata (Nueva Serie), Sección Zoología* 9: 25-46.
- WIESNER, J. 1992. Verzeichnis der Sandlaufkäfer der Welt. Checklist of the Tiger Beetles of the World. *Verlag Erna Bauer, Keltern*, 364 pp.



## **A taxonomic revision of the family Oncopodidae II. The genus *Gnomulus* Thorell (Opiliones, Laniatores)**

Peter J. SCHWENDINGER<sup>1</sup> & Jochen MARTENS<sup>2</sup>

<sup>1</sup>Institut für Zoologie und Limnologie, Universität Innsbruck, Technikerstr. 25, A-6020 Innsbruck, Austria.

Present address: Muséum d'histoire naturelle, Case postale 6434, CH-1211 Genève 6, Switzerland.

<sup>2</sup>Institut für Zoologie, Johannes Gutenberg-Universität Mainz, Saarstr. 21, D-55099 Mainz, Germany.

**A taxonomic revision of the family Oncopodidae II. The genus *Gnomulus* Thorell (Opiliones, Laniatores).** - The 27 formally recognized species of *Gnomulus* Thorell, 1890 are listed and placed in six provisional species groups. Poorly known species are rediagnosed. *Gnomulus segnipes* (Loman) is placed in synonymy with *G. armillatus* (Thorell). Both nominal species occur only in western Sumatra; corresponding records from outside Sumatra are attributed to other species, some of them undescribed. For *G. aborensis* (Roewer), *G. rostratus* Thorell, *G. insularis* (Roewer), *G. piliger* (Pocock), *G. pulvillatus* (Pocock), *G. sumatranus* Thorell and *G. annulipes* (Pocock) penis morphology is illustrated for the first time. Additional illustrations are presented for *G. sundaicus* (Schwendinger), *G. laevis* (Roewer) and *G. goodnighti* (Suzuki). Intraspecific variation is discussed. The original designation of *G. sumatranus* as the type species of *Gnomulus* is maintained, despite being in conflict with the International Code of Zoological Nomenclature.

**Key-words:** Opiliones - Oncopodidae - taxonomy - Asia.

### INTRODUCTION

Following part I of our revision of the Oncopodidae (MARTENS & SCHWENDINGER 1998), where seven new and unusual species of *Gnomulus* were described, we now continue with a more comprehensive study of this species-rich genus. Considering the large material available, including several additional new species, it appears more practical to split our treatment of *Gnomulus* into two parts. In this paper we present a revision of the already known species, provisionally assigned to species

groups and listed in geographical order roughly from northwest to southeast. Hereby we focus on species described before 1969, for many of which male genital characters can be shown. For a few species described more recently, new specimens are illustrated to provide additional information on intraspecific variation. In our next article descriptions of several new *Gnomulus* species shall follow.

Abbreviations and terms used in the text: AMNH American Museum of Natural History; NHML Natural History Museum, London (formerly British Museum of Natural History); MAR collection of J. Martens, Mainz; MSNG Museo Civico di Storia Naturale, Genova; MHNG Muséum d'histoire naturelle, Genève; MHNP Muséum National d'Histoire naturelle, Paris; SMF Naturmuseum und Forschungsinstitut Senckenberg, Frankfurt; ZMA Zoologisch Museum, Universiteit van Amsterdam; ZMB Museum für Naturkunde der Humboldt-Universität, Berlin; ZMC Zoologisk Museum, København; ZMH Zoologisches Institut und Museum, Universität Hamburg; ZMT Zoological Museum, University of Turku.

Body measurements refer to the distance between the anterior margin of the carapace and the posterior margin of the dorsal scutum. Leg articles were measured on their dorsal side, from joint to joint. All measurements are given in mm. Terminology of penis morphology follows that of MARTENS & SCHWENDINGER (1998: fig. 1 - showing dorsal and lateral but not ventral view as given in the corresponding legend). The dorsal connection between the prosomal and opisthosomal part of the dorsal scutum, formed by paired or unpaired tooth-like processes or lobes (e.g. Figs 28-30), is here called the "carapace-abdomen bridge".

## TAXONOMY

### **Gnomulus** Thorell, 1890

*Gnomulus* Thorell (1890: 378), type species by original designation, *G. sumatranus* Thorell, 1891<sup>1</sup>. - Pocock (1897: 285). - LOMAN (1902: 182). - ROEWER (1923: 60-61). - SCHWENDINGER (1992: 197). - MARTENS & SCHWENDINGER (1998: 526).

*Pelitus* Thorell (1891: 757), type species by original designation, *P. armillatus* Thorell, 1891. - POCKOCK (1897: 285). - LOMAN (1902: 182). - ROEWER (1923: 62). - SØRENSEN (1932: 213). - SCHWENDINGER (1992: 197). - MARTENS & SCHWENDINGER (1998: 501, 526).

*Diagnosis:* See MARTENS & SCHWENDINGER (1998: 526).

<sup>1</sup> The original designation of *G. sumatranus* Thorell, 1891 as the type species of *Gnomulus* Thorell, 1890 was never questioned by subsequent authors, although it does not accord with the International Code of Zoological Nomenclature (INTERNATIONAL TRUST FOR ZOOLOGICAL NOMENCLATURE 1985). *Gnomulus sumatranus* was then not a nominal species (but a "nomen nudum") and *G. rostratus* Thorell, 1890 was the only species available in this genus. Hence article 68c (monotypy) of the code would have to be applied, making *G. rostratus* the type species. However, there was no such code in 1890 for Thorell to obey and we think that he had good reasons to favour *G. sumatranus* above *G. rostratus*. Therefore the original designation should be maintained. A corresponding proposal (case 3116) has been submitted to the International Commission on Zoological Nomenclature (SCHWENDINGER & MARTENS 1999).

*Species account and distribution:* 27 nominal species, here placed in six provisional species groups, are known from the Himalayan region and from Southeast Asia (Fig. 1).

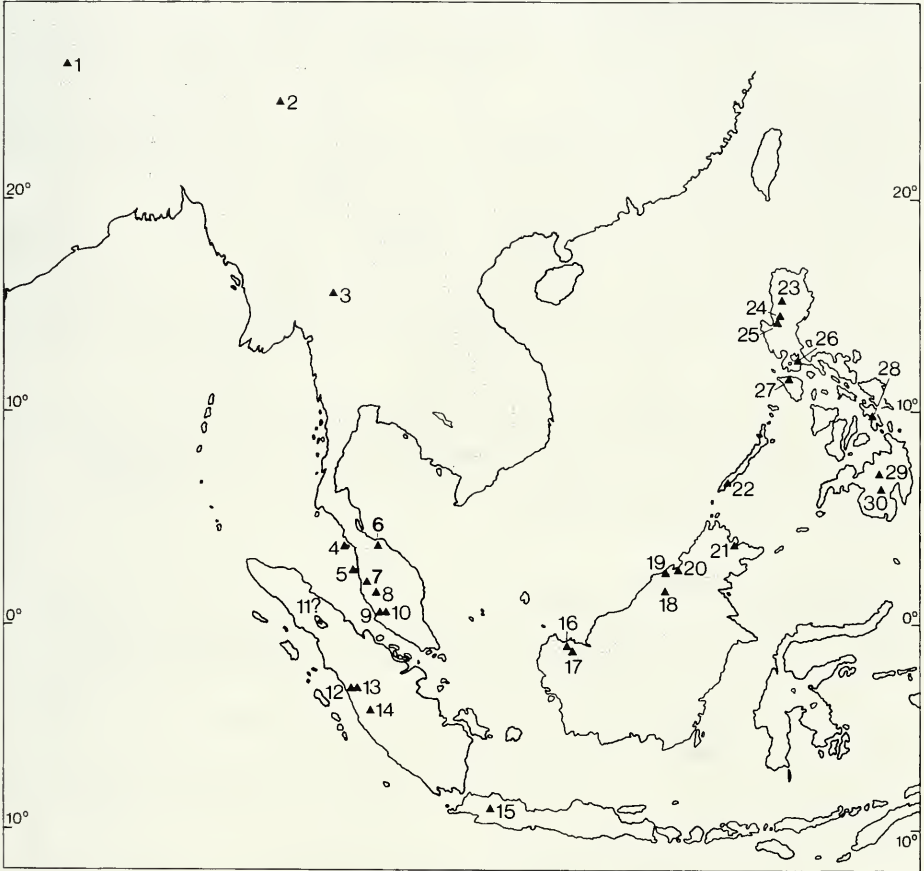

FIG. 1

Distribution of *Gnomulus* in the Himalayan region and in Southeast Asia. - 1 Ulleri (*G. hyatti*), 2 Rotung (*G. aborensis*), 3 Doi Inthanon (*G. lannaianus*), 4 Langkawi Island (*G. insularis*), 5 Penang Island (*G. insularis*, *G. rostratus*), 6 Bukit Besar (*G. piliger*), 7 Maxwell Hill (*G. laruticus*), 8 Chenderiang (*G. rostratus*, *G. asli*), 9 Batu Caves (*G. pulvillatus*), 10 Templer Park, Ulu Gombak, Genting Highlands (*G. hirsutus*), 11 Dolok Banol - location unknown (*G. drescoi*), 12 Gunung Singgalang (*G. sunatranus*, *G. armillatus*), 13 Bukittinggi, Anai. Ajer Mancior, Kayutanam (*G. armillatus*), 14 Gunung Kerinci (*G. armillatus*), 15 Cibodas (*G. thorelli*), 16 Kuching, Matang (*G. laevis*), 17 Kuching, Bau, Serian (*G. sundaicus*), 18 Baram River, Gunung Mulu (*G. annulipes*), 19 Andulau, Sungai Lubang Baru (*G. baharu*), 20 Amo (*G. imadatei*), 21 Kabili-Sepilok, Kolapis (*G. conigerus*), 22 Mt. Matalingajan (*G. palawanensis*), 23 Sagada (*G. maculatus*), 24 Crystal Caves (*G. coniceps*), 25 Mt. Santo Thomas (*G. crucifer*), 26 Mt. Makiling (*G. minor*), 27 Puerto Galera (*G. maculatus* - doubtful record), 28 Visca (*G. leyteensis*), 29 Mt. Katanglad (*G. goodnighti*), 30 Mt. McKinley (*G. goodnighti*).

THE *ABORENSIS*-GROUP

*Diagnosis*: Medium-sized to large species with robust cheliceral hands in males, low interocular areas, medially divided dorsal scutal areas and short, blunt lateral sclerites on glans penis.

This group comprises three species from Nepal, NE-India and N-Thailand.

**Gnomulus hyatti** (Martens, 1977)

Fig. 18

*Pelitmus hyatti* Martens (1977: 296-298, figs 1-8); description of ♂ and ♀. - SCHWENDINGER (1992: 178, 197).

*Gnomulus hyatti* (Martens); MARTENS & SCHWENDINGER (1998: 526).

*Types*: NEPAL. Ulleri, 1800-2200 m, ♂ holotype (NHML, examined), 1 ♀ paratype (SMF 29229, examined), leg. K. H. Hyatt, 19.V.1954.

*Remark*: No additional material of this species is available although several new and unusual oncopodid specimens have since been collected at other localities in Nepal.

*Relationships*: *Gnomulus hyatti* is close to *G. lanaiianus* and *G. aborensis*. Unlike the latter two species, *G. hyatti* has a fairly short (about 2.2 times longer than wide) distitarsus II (Fig. 18) and a less pronounced external sexual dimorphism.

*Distribution*: Known only from the type locality, in the southern part of the Annapurna massif, central Nepal (Fig. 1).

**Gnomulus aborensis** (Roewer, 1913)

Figs 2-17

*Pelitmus aborensis* Roewer (1913: 207); description of species, without distinction of sexes.

*Gnomulus aborensis* (Roewer); Roewer (1923: 62, figs 65 a, b). - SCHWENDINGER (1992: 197). - MARTENS & SCHWENDINGER (1998: 526).

*Types*: INDIA. Abor District, Rotung, ca. 400 m, Upper Rotung, ca. 620 m, 2 syntypes (Museum Calcutta, not examined), leg. S. W. Kemp, 21/31.XII.1911.

*Other material*: Abor District, 2 ♂, 1 ♀ (SMF 1257), not mentioned in the original description but recorded as "cotypes" by ROEWER (1923: 62), possibly part of the original series of specimens examined by Roewer.

*Diagnosis*: Fairly large species, characterized by: arched carapace without distinct eye tubercle, with pronounced lateral tubercles below carapace-abdomen bridge (Figs 8-11; ROEWER 1923: fig. 65b); dorsal scutum high, areas I-VII elevated, medially divided by a pronounced longitudinal furrow and separated from each other by transversal furrows (Figs 8-11; ROEWER 1923: fig 65a); coxa I ventrally with distinct antero-lateral process, coxae II and III with antero-proximal one, coxa II with additional postero-proximal one; chelicerae fairly robust, proximal article with a distad-inclined proventral process (Figs 12-15); palp with conical ventral process on trochanter, a low rounded ventral process and a distinct dorsal boss proximally on femur (Fig. 16); distitarsus of leg II about 2.7 times longer than wide (Fig. 17). External sexual dimorphism in shape and size of carapace and chelicerae, being distinctly larger in ♂♂ (Figs 8-9, 12-13); ventral scutal elevation of ♂ only little swollen and covered with plenty of fine hairs (Fig. 8). Truncus penis fairly slender.



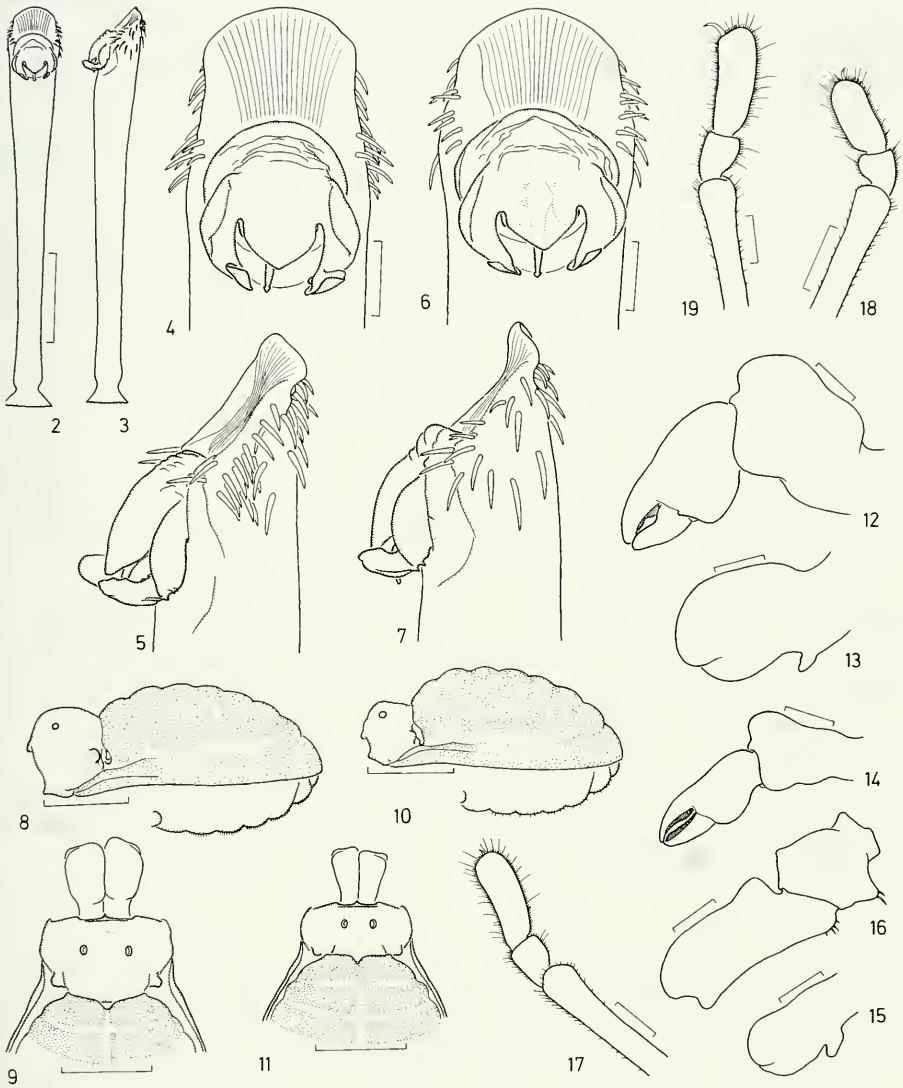

FIGS 2-19

*Gnomulus aborensis* (Roewer) (2-17), *G. hyatti* (Martens) (18), *G. lamaianus* (Schwendinger) (19). - Penis, dorsal (2) and lateral view (3); apex of penis of 2 ♂, dorsal (4, 6) and lateral view (5, 7). Body of ♂ (8) and of ♀ (10), lateral view; anterior part of body and chelicerae of ♂ (9) and of ♀ (11), dorsal view; left chelicera of ♂ (12) and ♀ (14), retrolateral view; proximal article of right chelicera of ♂ (13) and of ♀ (15), prolateral view; trochanter and femur of left palp of ♂, retrolateral view (16); distal part of left (17, 19) and of right leg II (18), retrolateral view. - Scale lines 0.1 mm (4-7), 0.5 mm (2, 3, 12-19), 1.0 mm (8-11).

with strongly arched distal margin. Glans penis with more or less pentagonal median plate not covering outer side of membraneous tubes; lateral sclerites stout, with prominent outer margin, strong wrinkles on lower face and blunt tip; stylus slender (Figs 2-6).

*Variation:* Measurements ( $\delta$ , in brackets  $\text{♀}$ ): body 5.88-6.78 (6.13) long, 4.44-4.88 (4.53) wide; carapace region 1.51-1.87 (1.25) long, 2.54-2.94 (2.48) wide;  $\delta$  (n = 2),  $\text{♀}$  (n = 1).

*Relationships:* *Gnomulus aborensis* is closest to *G. lannaianus*. Both share sexual dimorphism in the size of carapace and chelicerae and possess a long (more than 2.5 times longer than wide) distitarsus II. Due to differences in penis morphology and scutal surface structure, *Gnomulus hyatti* appears more distant to these two species.

*Distribution:* Known only from the foothills of the Himalaya in Arunachal Pradesh, northeastern India (Fig. 1).

### ***Gnomulus lannaianus* (Schwendinger, 1992)**

Fig. 19

*Pelittus lannaianus* Schwendinger (1992: 178-180, 197, figs 1-13); description of  $\delta$  and  $\text{♀}$ .  
*Gnomulus lannaianus* (Schwendinger): MARTENS & SCHWENDINGER (1998: 527).

*Types:* THAILAND, Chiang Mai Province, Doi (= Mount) Inthanon. 2300-2530 m,  $\delta$  holotype, 1  $\delta$ , 7  $\text{♀}$  paratypes (MHNG, examined), leg. P. Schwendinger, X.1986-X.1987.

*Remark:* No new material available. Distitarsus II is about 2.8 times longer than wide (Fig. 19).

*Relationships:* A close relationship between *G. lannaianus* and *G. hyatti* was already pointed out by SCHWENDINGER (1992: 197).

*Distribution:* Known only from the summit area of Doi Inthanon (northern Thailand), where several other remarkable animal and plant species with affinities to the Himalayan region occur (Fig. 1).

### THE *ROSTRATUS*-GROUP

*Diagnosis:* Medium-sized species with distinctly antierad-inclined pointed eye tubercles and unique penis morphology, i.e. median plate of glans long and narrow, stylus distally very wide, shaped like a depressed bell.

This group includes two species from the west of peninsular Malaysia and nearby islands.

### ***Gnomulus insularis* (Roewer, 1927)**

Figs 20-37

*Pelittus insularis* Roewer (1927: 268); description of  $\delta$ . - SCHWENDINGER (1992: 197).  
*Gnomulus insularis* (Roewer): MARTENS & SCHWENDINGER (1998: 526).

*Type:* MALAYSIA, Pulu Pinang (= Pulau Pinang = Penang Island) - doubtful indication of locality.  $\delta$  holotype (SMF 301, examined).

*Other material:* MALAYSIA, Kedah, Langkawi Island, 3  $\delta$ , 1  $\text{♀}$  (NHML), leg. P. D. Hillyard, II.1983.

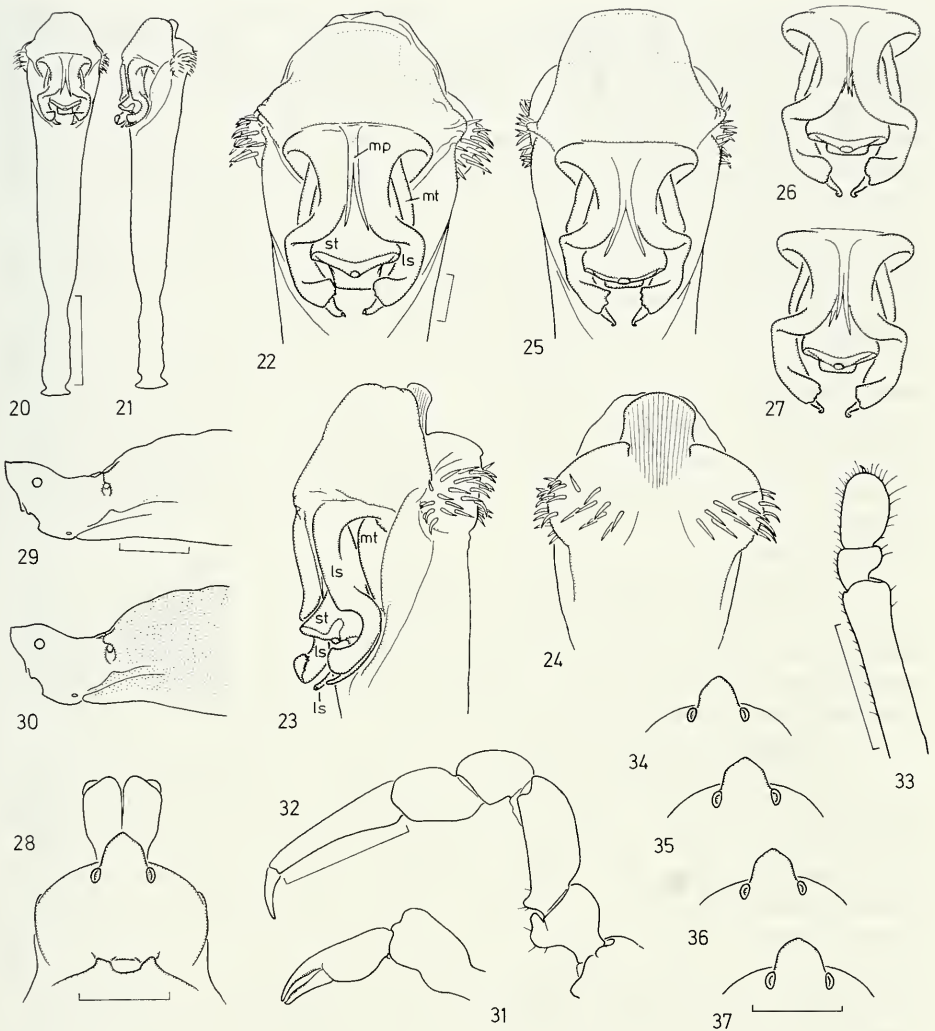

FIGS 20-37

*Gnomulus insularis* (Roewer), ♂ holotype (25, 28-29, 31-33). - Penis, dorsal (20) and lateral view (21); apex of penis, dorsal (22), lateral (23) and ventral view (24); apex of penis (25) and glans penis (26-27) of 3 ♂, dorsal view. Anterior body of ♂, dorsal (28) and lateral view (29). Anterior body of ♀, lateral view (30); left chelicera (31), left palp (32) and distal part of left leg II (33), retrolateral view; eye tubercles of 3 ♂ (34-36) and 1 ♀ (37) from Langkawi Island, dorsal view. - Scale lines 0.1 mm (22-27), 0.5 mm (20-21), 1.0 mm (28-37).

*Diagnosis:* Medium-sized species with pointed, anteriad-inclined eye tubercle (Figs 29-30; ROEWER 1927: fig. 4b), pentagonal in dorsal view, with lateral margins converging from base to tip (Figs 28, 34-37); carapace-abdomen bridge composed of two opposing pairs of conical processes (Fig. 28); scutal areas only indistinctly elevated, ventral ones of ♂♂ more densely covered with fine hairs than in ♀♀; chelicerae weak, with disto-dorsal boss and low ventro-median hump (Fig. 31); palp with distad-inclined process ventrally on trochanter and conical proximo-ventral process on femur (Fig. 32); distitarsus II about 1.6 times longer than wide (Fig. 33); coxa I ventrally with small anterio-lateral process, coxa II ventrally with anterio- and posterio-proximal processes, coxa III ventrally with anterio-proximal one. Penis fairly stout; truncus with a constriction behind proximal 1/4, apex very narrow, clearly separated from rest of truncus (Fig. 24). Glans penis with very large membranous socket obscuring apex of truncus in dorsal view; lateral sclerites forceps-like, its apices split into a scoop-like and a filiform part; median plate very narrow, split into 2-4 pointed tips; membranous tubes visible below subbasal constriction of lateral sclerites; stylus very wide, shaped like a flattened bell, with a quadrangular extension projecting from the inner side behind the opening of the sperm duct (Figs 20-27, see also Fig. 69c-e).

*Variation:* Measurements (♂, in brackets ♀): body 5.36-5.83 (6.17) long, 3.20-3.52 (3.70) wide; carapace region 1.25-1.41 (1.44) long, 1.82-1.93 (1.90) wide; leg II (measured in its entirety) 7.67-8.29 (8.23) long; ♂ (n = 4), ♀ (n = 1). The median plate of the glans penis is distally split into 2-4 tips (Figs 22, 25-27). The observed variation in the shape of the eye tubercles is only slight (Figs 28, 34-37).

*Relationships:* *Gnomulus insularis* is closest to *G. rostratus*.

*Distribution:* Apparently present on two islands off the northern west coast of peninsular Malaysia (Fig. 1). However, the report of the type specimen from Penang Island appears doubtful, since all other conspecific specimens available were collected on Langkawi Island, about 120 km to the north. Similar oncopodids, collected on Penang Island quite recently, all belong to the closely related *G. rostratus* (see below). Therefore, either both species occur on Penang Island (with the possibility of *G. rostratus* being introduced from the mainland), or the single record of *G. insularis* from Penang is incorrect. Considering that closely related species of Oncopodidae usually occur in allopatry and taking into account the unreliability of Roewer's locality indications (see HELVERSEN & MARTENS 1972), we are in favour of the latter explanation.

### **Gnomulus rostratus** Thorell, 1890

Figs 38-69

*Gnomulus rostratus* Thorell (1890: 378-381); description of species, without distinction of sexes. - ROEWER (1923: 61). - SCHWENDINGER (1992: 197).

*Type:* MALAYSIA, Pulo Pinang (= Penang Island), ♀ holotype (MSNG, examined), leg. L. Fea & L. Loria, 1889.

*Other material:* MALAYSIA, Penang Island, Penang Hill (= Bukit Bendera), 650-760 m, 1 ♂ (decayed, penis complete), 1 ♀ (19.I.1995), 710 m, 2 ♂ (8.-9.XII.1997); - Perak, forest ca. 5 km northeast of Chenderiang, 290-330 m, 4 ♂, 1 ♀ (22.-31.I.1994), 330-400 m, 1 ♂, 1 ♀ (15.-22.I.1995); all specimens leg. P. Schwendinger. - Perak, without locality, 1 ♀ (SMF 5104, "*Pelitus segnipēs* ♂", Roewer det. 1932).

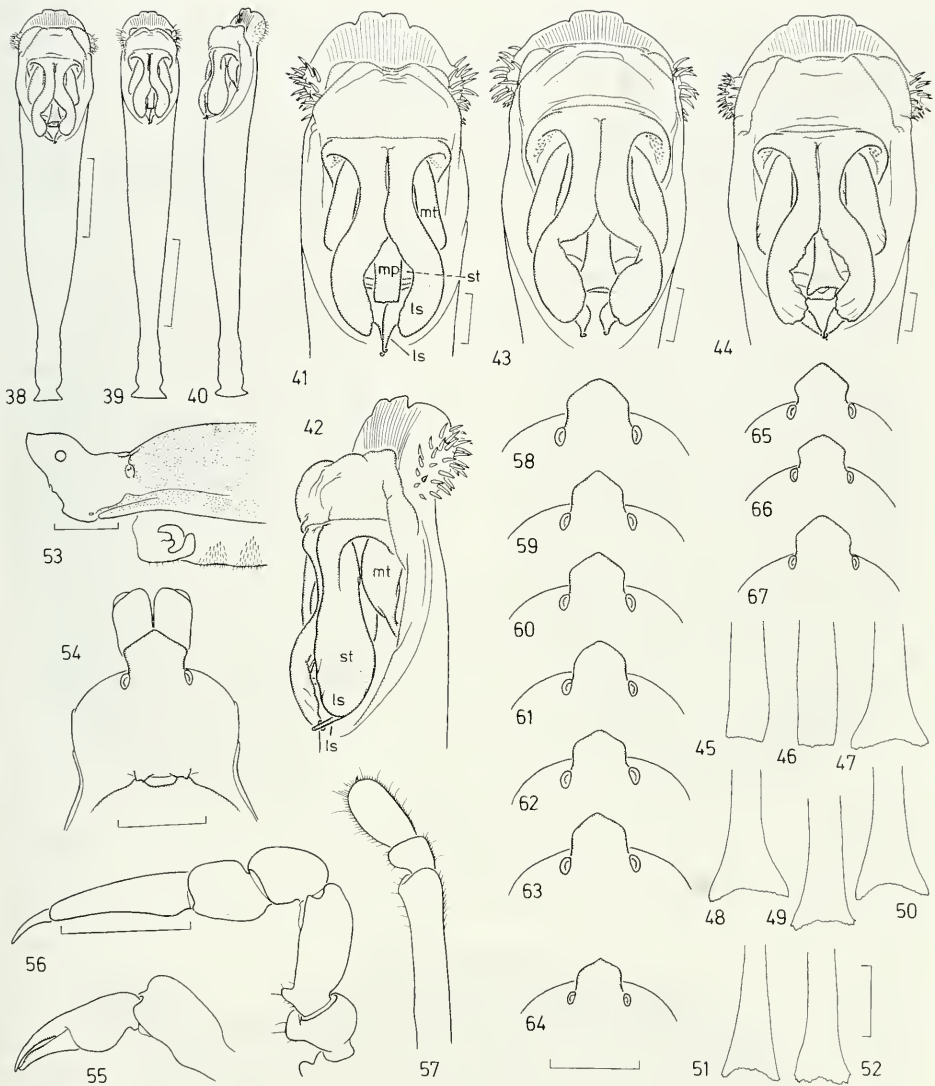

FIGS 38-67

*Gnomulus rostratus* Thorell, ♀ holotype (55-57). - Penis of ♂ from Penang, dorsal view (39), lateral view (40), apex of penis, dorsal (41), lateral view (42); apex of penis of other ♂ from Penang (43); total penis (38) and apex of penis (44) of ♂ from Chenderiang; median plate of glans of 3 ♂ from Penang (45-47) and of 5 ♂ from Chenderiang (48-52). Anterior body of ♂, lateral view (53) and dorsal view (54); left chelicera (55), left palp (56) and distal part of right leg II (57), retrolateral view; eye tubercle of 2 ♀ (58-59) and 4 ♂ (60-63) from Chenderiang, of 1 ♀ from Perak (64), of 2 ♂ (65-66) and 1 ♀ (67) from Penang, dorsal view. - Scale lines 0.1 mm (41-52), 0.5 mm (38-40), 1.0 mm (53-67).

*Diagnosis:* Very similar to *G. insularis*, distinguished by eye tubercle wider in dorsal view, with lateral margins parallel or divergent (from base towards tip) in basal part (Figs 54, 58-66); dorsal scutum of ♀ lower (Fig. 68c); distitarsus II about 1.8 times longer than wide (Fig. 57). Penis different in: apex of truncus penis much wider; membranous socket of glans smaller, not covering apex of truncus in dorsal view; lateral sclerites less distinctly sigmoid, covering lateral parts of stylus; median plate entire, about as long as stylus, distal margin evenly truncate, or widened and invaginated (Figs 38-52, Fig. 69c-e).

*Variation:* Measurements range (♂, in brackets ♀): body 5.42-5.86 (5.42-6.26) long, 3.21-3.62 (3.27-3.90) wide; carapace region 1.45-1.65 (1.38-1.68) long, 1.79-2.09 (1.79-2.14) wide; leg II (measured in its entirety) 7.89-9.10 (7.39-8.91) long; ♂ (n = 8), ♀ (n = 5). The specimens from Chenderiang (n = 7) all have a slightly wider body and a longer leg II than the others. The truncus penis of ♂♂ from Chenderiang (Fig. 38) is stouter than in those from Penang (Fig. 39). The median plate of the glans is distally widened and invaginated in all ♂♂ from Chenderiang (Figs 48-52) and in one from Penang (Fig. 47), in 2 ♂ from Penang it is parallel-sided and evenly truncate (Figs 45-46).

*Relationships:* *Gnouulus rostratus* and *G. insularis* are close to each other but quite distinct from the other species in *Gnouulus*.

*Distribution:* Known from Penang Island and from two localities (one of them not specified) in Perak, on the Malay Peninsula (Fig. 1). A juvenile specimen from Maxwell Hill (= Bukit Larut, near Taiping, 1320 m, leg. P. Schwendinger), which lies in between Penang and Chenderiang, probably also belongs to *G. rostratus*.

*Remarks:* It first appeared that the ♀ type of *G. rostratus* and the ♂ type of *G. insularis* are conspecific (see MARTENS & SCHWENDINGER 1998: 526-527) since both are supposed to originate from Penang Island. After thorough examination and comparison with the newly collected specimens from Penang and Langkawi Islands, however, it turned out that the two types really do belong to different species. The *G. rostratus* type (Fig. 68) has the same basally wide eye tubercle (seen in dorsal view) as all new specimens from Penang and Perak (Figs 54, 58-67), but it has a distinctly less elevated dorsal scutum than the *G. insularis* ♀ from Langkawi (Fig. 30). The *G. insularis* type, on the other hand, has a basally narrow eye tubercle (Fig. 28) and a penis (Fig. 25) as in the specimens from Langkawi (Figs 22, 26-27).

The pubescence on the ventral scutal areas of ♂♂ is more conspicuous than in ♀♀, best seen in dry specimens. The hair shafts are coated by a crust arranged in longitudinal furrows (Figs 69a, b), which makes these hairs appear stronger and lighter in colour than the bare hairs on other parts of the ♂ body or on the ventral scutal areas of ♀♀. The crust is made of a crystallized secretion, which seemingly originates from glands at the hair bases. Such modified hairs have already been recognized in *G. piliger* and *P. pulvillatus* by POCOCK (1903: 413 - "transverse bands of coarse pubescence") and *G. insularis* by ROEWER (1927: 268 - "Querband kurzer Haare") and they occur in a number in other species as well. What significance these hairs have (presumably before or during mating), has yet to be learnt from histological studies and biological observations.

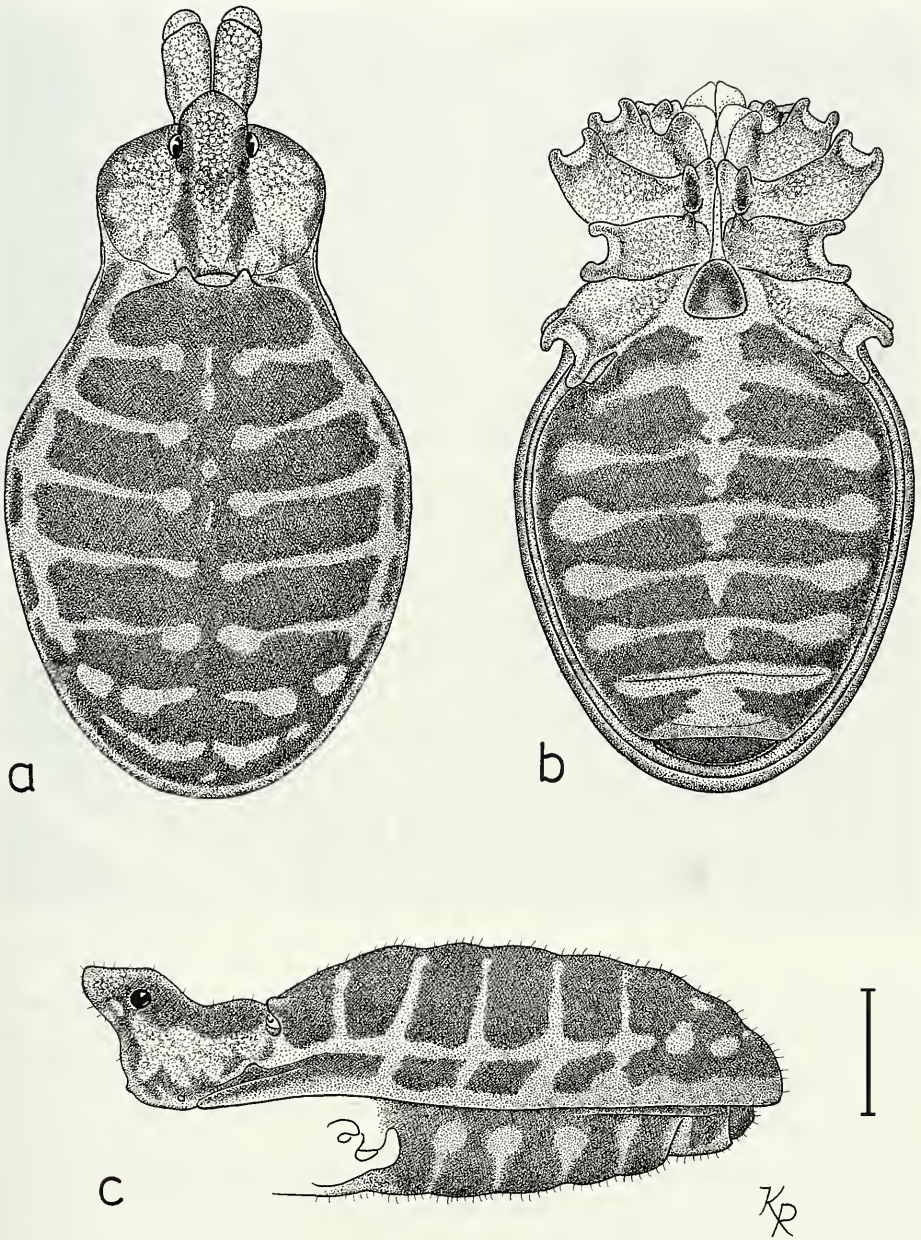

FIG. 68

*Gnomulus rostratus* Thorell, ♀ (holotype, with colour pattern drawn from syntopic ♀ specimen), body, dorsal (a), ventral (b) and lateral view (c). - Scale line 1.0 mm.

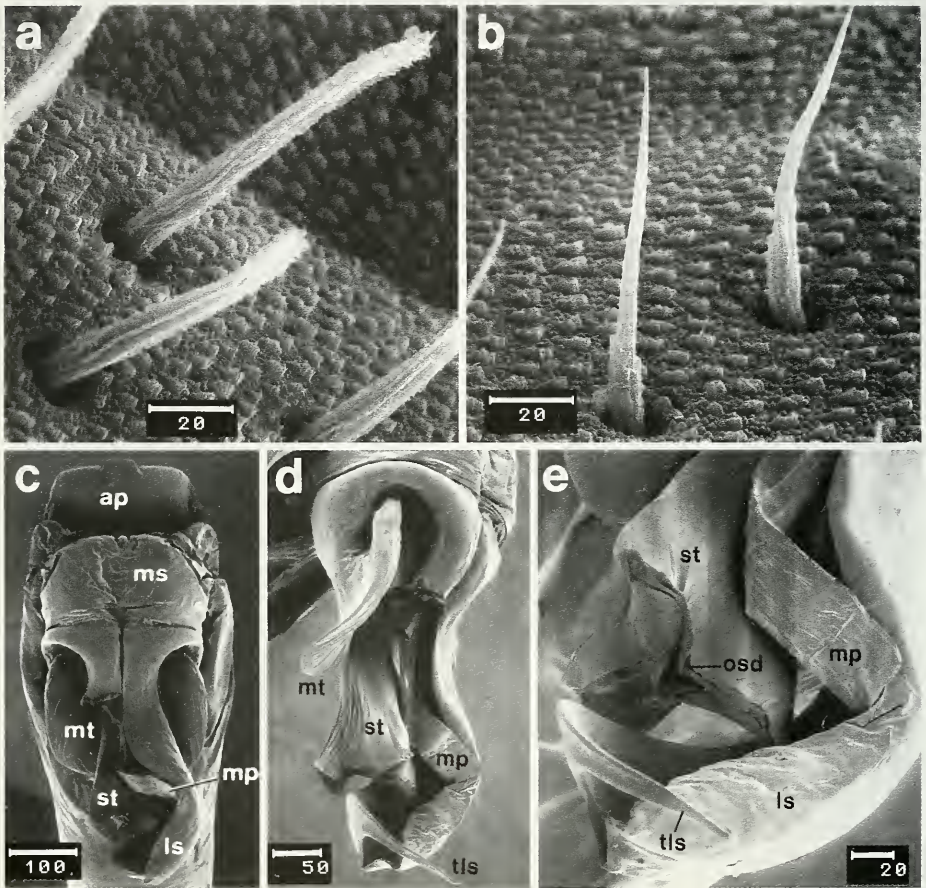

FIG. 69

Scanning electron micrographs of *Gnomulus rostratus* ♂. - Hairs on ventral scutal areas coated in a crust of crystallized secretion (a), the same with crust partly broken off (b). Distal part of penis with lateral sclerites on left side removed, dorsal view (c), lateral view (d); stylus, disto-lateral view (e). - Scale lines 20 µm (a, b, e), 50 µm (d), 100 µm (c).

#### THE ASLI-GROUP

*Diagnosis:* Small to very small species with rounded eye tubercles and curved, narrow, acutely pointed lateral sclerites on glans penis.

This group comprises three species from the Malay Peninsula.

#### *Gnomulus laruticus* Martens & Schwendinger, 1998

*Gnomulus laruticus* Martens & Schwendinger (1998: 539-542, figs 105-113): description of ♂.

*Type:* MALAYSIA, Perak, Taiping, Maxwell Hill, 1320 m. ♂ holotype (MHNG, examined), leg. P. Schwendinger, 26.I.1995.



*Remark:* No new material available.

*Relationships:* Despite its unusual tarsal formula (2-2-2-2; shared only by *G. crucifer*), genital morphology shows that *G. laruticus* is closely related to *G. asli* and *G. hirsutus*.

*Distribution:* Known only from the summit area of Maxwell Hill (= Bukit Larut) in peninsular Malaysia (Fig. 1).

### ***Gnomulus asli* Martens & Schwendinger, 1998**

*Gnomulus asli* Martens & Schwendinger (1998: 542-544, figs 114-122); description of ♂ and ♀.

*Types:* MALAYSIA, Perak, forest 5 km northeast of Chenderiang, 290-400 m. ♂ holotype (MHNG, examined), 2 ♂, 7 ♀ paratypes (MAR, MHNG, examined), leg. P. Schwendinger, I.1994, I.1995.

*Remark:* No new material available.

*Distribution:* Known only from the type locality in peninsular Malaysia (Fig. 1), where *G. asli* occurs syntopically with *G. rostratus*, with a third *Gnomulus* species (carrying a conical eye tubercle; 1 juvenile available) and with an *Oncopus* species (1 ♀ available).

### ***Gnomulus hirsutus* Martens & Schwendinger, 1998**

*Gnomulus hirsutus* Martens & Schwendinger (1998: 545-548, figs 123-133); description of ♂ and ♀.

*Types:* MALAYSIA, Selangor, Templer Park, ♂ holotype (MHNG, examined), leg. C. Deeleman-Reinhold, 3.XII.1990; Templer Park and Ulu Gombak, 200 m, road to Genting Highlands, 500-800 m, 2 ♂, 1 ♀ paratypes (MAR, MHNG, examined), leg. D. Agosti - C. Deeleman-Reinhold - H. Ono.

*Remark:* No new material available.

*Relationships:* *Gnomulus hirsutus* and *G. asli* are closest relatives; *G. laruticus* appears to be more distant.

*Distribution:* Known from the area north of Kuala Lumpur, peninsular Malaysia (Fig. 1).

### THE *SUMATRANUS*-GROUP

*Diagnosis:* Large species with: massive chelicerae (especially in males), proximal and subdistal processes ventrally on palpal femora, low interocular areas, transversal keels on dorsal scuta and widely separated narrow, acutely pointed lateral sclerites on glans penis; anterio-proximal processes on ventral side of coxa II absent.

At present, this group is represented only by *G. sumatranus* from W-Sumatra; a related, undescribed species occurs in N-Sumatra.

### ***Gnomulus sumatranus* Thorell, 1891**

Figs 70-87

*Gnomulus sumatranus* Thorell (1891: 759-763, figs 37-40); description of species, without distinction of sexes. - LOMAN (1893: 25). - LOMAN [1903: figs O, V-f (illustration of penis), pl. 11, figs 19, 21]. - ROEWER (1923: 61-62, figs 64a-c). - SCHWENDINGER (1992: 197).

*Types*: SUMATRA, West Sumatra Province (Sumatera Barat), Mt. Singalang (= Gunung Singgalang); 1 ♂, 3 ♀, 2 juv. syntypes (MSNG, examined), leg. O. Beccari, VII.1878. ♂ here designated lectotype, because illustrated in the original description and carrying most relevant characters.

*Other material*: From the type locality, 1 ♂ with missing penis (removed by Loman; ZMA), leg. M. Weber; Gunung Singgalang, 2100-2600 m, 1 juv. (MAR), leg. A. Riedel, 16.X.1990.

*Diagnosis*: Distinguished by high carapace with indistinct eye tubercle; dorsal scutal areas with transversal keels (Figs 74-77); ventral side of coxa I with quite large, outwards-directed process, coxa II ventrally without antero-proximal process but with short, broadly rounded postero-proximal process, coxa III ventrally with indistinct antero-lateral process (Fig. 78); chelicerae very strong, with a triangular pro-ventral process on proximal article (Figs 79-81); palpal femur ventrally with a large, strongly distad-inclined proximal process and a short, conical subdistal process; palpal trochanter with a distad-inclined ventral process and a small, pointed dorsal process (Figs 82-86); distitarsus II about 2.7 times longer than wide (Fig. 87). External sexual dimorphism in: ♂♂ with longer, higher carapace (Figs 74-75), stronger chelicerae (Fig. 79), stronger processes ventrally on palpal femur (Figs 82-83) and more elevated ventral scutal areas (Fig. 74). Penis slender, with circular fold around subbasal truncus; glans penis quite remote from rounded apex of truncus; one seta on each side of membraneous socket of glans; lateral sclerites widely apart, very slender and acutely pointed, only little bent and running parallel to each other; median plate rounded, not covering tips of membraneous tubes; stylus long and slender (Figs 70-73).

*Variation*: Measurements (♂, in brackets ♀): body 8.81-8.94 (8.19-8.47) long, 5.81-6.28 (5.56-5.81) wide, carapace region 3.44-3.69 (2.75-2.88) long, 4.44-4.47 (3.56-3.81) wide; ♂ (n = 2), ♀ (n = 3). The larger juvenile from the type series (7.79 long) has 3-segmented posterior tarsi; in the smaller one (6.17 long) they are still 2-segmented (THORELL 1891: fig. 40).

The penis (probably lost) of the ♂ in ZMA, portrayed by LOMAN (1903: fig. V-f), seems to have a pronounced swelling at the position where the circular fold is found on the penis of the lectotype.

*Relationships*: Externally *G. sumatranus* appears very distinct from all other congeners, but penis morphology is quite similar to species of the *asli*-group.

*Distribution*: Known only from the surroundings of Gunung Singgalang, a mountain ca. 20 km south of Bukittinggi, West Sumatra Province (Fig. 1).

#### THE ARMILLATUS-GROUP

*Diagnosis*: Medium-sized to large species with more or less distinctly elevated conical (often pointed) eye tubercles and lateral glans sclerites, which are either paddle-shaped and bent, or narrow and pointed with a sigmoid or strongly curved course.

This group includes 11 species from peninsular Malaysia, Sumatra, Java, Borneo and Palawan Island (Philippines).

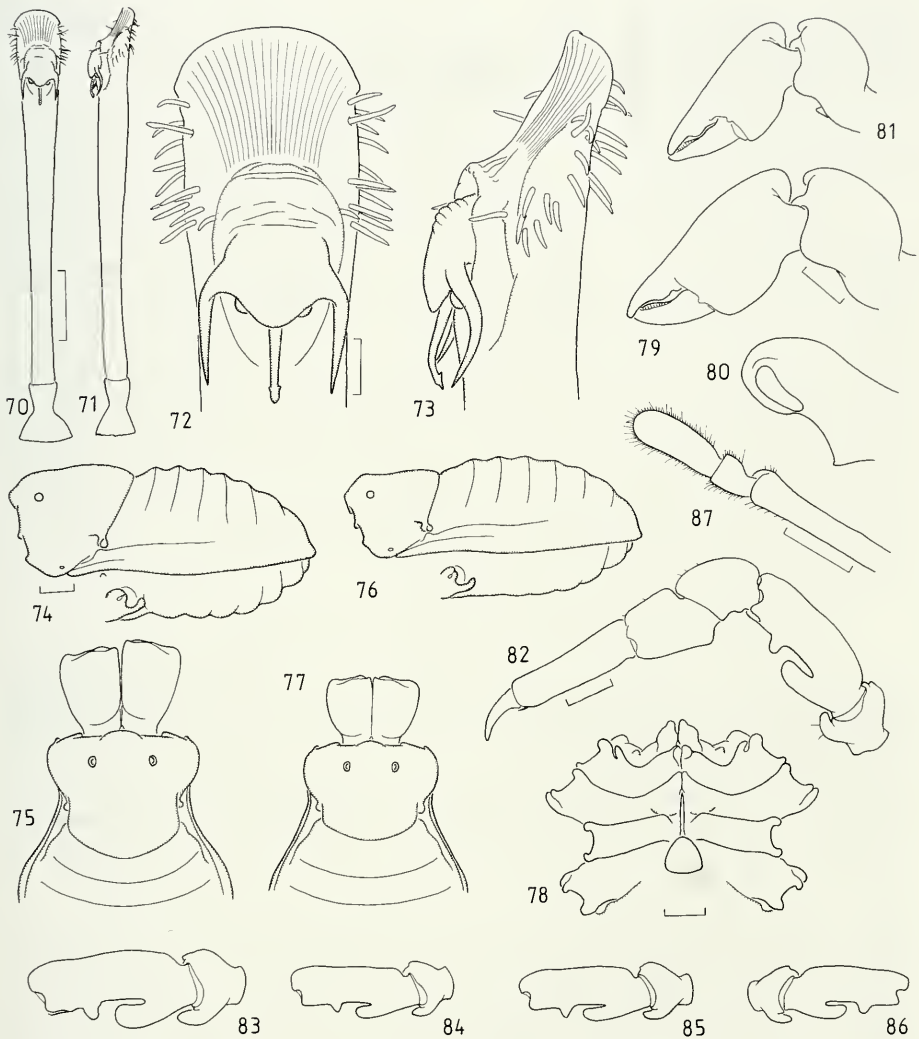

FIGS 70-87

*Gnomulus sumatranus* Thorell, ♂ lectotype (70-75, 78-80, 82, 87). - Penis, dorsal (70) and lateral view (71); apex of penis, dorsal (72) and lateral view (73). Body of ♂ (74) and of ♀ (76), lateral view; anterior body and proximal article of chelicerae of ♂ (75) and of ♀ (77), dorsal view; prosoma and genital operculum, ventral view (78); left chelicera of ♂ (79) and of ♀ (81), retrolateral view; proximal article of ♂ chelicera, proventral view (80); left palp, retrolateral view (82); trochanter and femur of left palp of other ♂ (83) and of 3 ♀ (84-86; 86 showing right palp), retrolateral view; distal part of left leg II, retrolateral view (87). - Scale lines 0.1 mm (72-73), 0.5 mm (70-71), 1.0 mm (74-87).

**Gnomulus piliger** (Pocock, 1903)

Figs 88-97

*Pelitus piliger* Pocock (1903: 413); description of species, without distinction of sexes. - ROEWER (1923: 64). - SCHWENDINGER (1992: 197).

*Gnomulus piliger* (Pocock): MARTENS & SCHWENDINGER (1998: 527).

*Type*: THAILAND, Bukit Besar, 750 m. ♂ holotype (NHML, examined), leg. Annandale & Robinson, 4.V.1901.

*Diagnosis*: Medium-sized species with rounded eye tubercle, wide, indistinctly divided carapace-abdomen bridge and moderately elevated dorsal scutal areas (Figs 92-93); proximal article of chelicerae with dorso-distal boss and wide retro-ventral tubercle (Fig. 95); large distad-inclined processes ventrally on trochanter and ventro-basally on femur of palp (Fig. 92), palpal femur fairly large in dorsal view (Fig. 96); distitarsus II about 2.3 times longer than wide (Fig. 97); coxa I ventrally with small antero-lateral process, coxae II and III with pronounced antero-proximal processes (no postero-lateral one on coxa II; Fig. 94); ventral scutal areas swollen and covered by fine hairs. Penis slender, widening towards the apex, distal margin slightly invaginated; lateral sclerites of glans penis thin, sigmoid, median plate broadly U-shaped, covering membranous tubes; stylus slender (Figs 88-91).

*Measurements*: Body 5.92 long, 4.36 wide; carapace region 1.25 long, 2.24 wide; leg II (measured in its entirety) 12.45 long.

*Relationships*: This species is very close to *G. pulvillatus*.

*Distribution*: Known only from Bukit Besar (now called Khao Sankalakhiri), a mountain of 890 m altitude, situated in the Nam Tok Sai Khao National Park, about 20 km northwest of Yala city, where the borders of the provinces Songkhla, Pattani and Yala meet.

*Remarks*: It was somewhat difficult to correctly locate "Bukit Besar", the type locality of *G. piliger*. In ROEWER (1923: 64) we find it located in "Malakka" (= peninsular Malaysia) and as it is a Malay name (meaning "big hill"), it seemed likely that it lies in Malaysia. Moreover, there are at least three mountains called "Bukit Besar" and another three called "Gunung Besar" (meaning "big mountain") in peninsular Malaysia. Only after receiving from the NHML the itinerary and map of the corresponding expedition (ANNANDALE & ROBINSON 1903), it became clear that the holotype was actually collected in an area which in 1901 was a Malay state under Siamese rule and today is part of Thailand. The same locality was also visited by the "Skeat-Expedition" in 1899-1900, in which Annandale took part as well (SKEAT 1954).

**Gnomulus pulvillatus** (Pocock, 1903)

Figs 98-107

*Pelitus pulvillatus* Pocock (1903: 413); description of species, without distinction of sexes. - ROEWER (1923: 64). - SCHWENDINGER (1992: 197).

*Gnomulus pulvillatus* (Pocock): MARTENS & SCHWENDINGER (1998: 527).

*Type*: MALAYSIA, "Selangore, in cave" or "The Caves; Selangore" (as written on two labels in the vial with the type), ♂ holotype (NHML, examined), leg. H. N. Ridley, 1897.

*Diagnosis*: Similar to *G. piliger* but distinguished by a more elevated, narrow eye tubercle; ventral processes on palpal femur and trochanter smaller, less distinctly

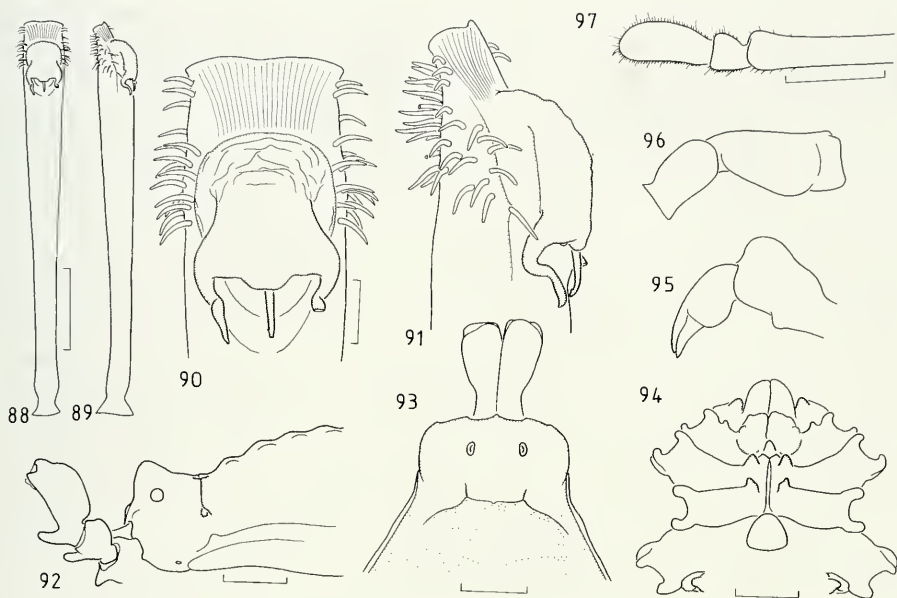

FIGS 88-97

*Gnomulus piliger* (Pocock), ♂ holotype. - Penis, dorsal (88) and lateral view (89), apex of penis, dorsal (90) and lateral view (91). Anterior body and proximal palp, lateral view (92); anterior body and chelicerae, dorsal view (93); prosoma and genital operculum, ventral view (94); left chelicera, retrolateral view (95); trochanter and femur of left palp, dorsal view (96); distal part of left leg II, retrolateral view (97). - Scale lines 0.1 mm (90-91), 0.5 mm (88-89), 1.0 mm (92-97).

distad-inclined (Fig. 102), palpal femur slightly smaller in dorsal view (Fig. 106); distitarsus II about 2.6 times as long as wide (Fig. 107); coxae II with postero-proximal process (Fig. 104); truncus penis stouter, with an isolated pair of setae on each side of narrower membranous socket of glans; lateral sclerites of glans slightly stronger, median plate very widely V-shaped, covering membranous tubes; stylus slender (Figs 98-101).

*Measurements:* Body 6.11 long, 4.36 wide; carapace region 1.25 long, 2.24 wide; leg II (measured in its entirety) 12.58 long.

*Relationships:* *Gnomulus pulvillatus* and *G. piliger* appear closely related to *G. armillatus* from Sumatra.

*Distribution and bionomics:* The caves, where the type specimen was collected, are most likely the famous Batu Caves, north of Kuala Lumpur (Fig. 1). Ridley was the first to carry out a zoological investigation of these caves, which he then called the "Selangore Caves" (RIDLEY 1898).

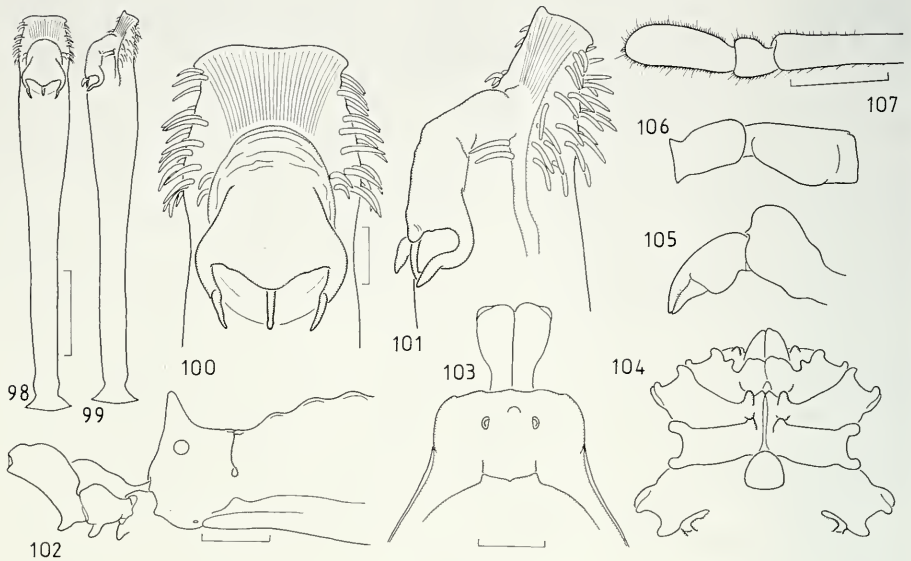

FIGS 98-107

*Gnomulus pulvillatus* (Pocock), ♂ holotype. - Penis, dorsal (98) and lateral view (99); apex of penis, dorsal (100) and lateral view (101). Anterior body and proximal palp, lateral view (102); anterior body and chelicerae, dorsal view (103); prosoma and genital operculum, ventral view (104); left chelicera, retrolateral view (105); trochanter and femur of left palp, dorsal view (106); distal part of left leg II, retrolateral view (107). - Scale lines 0.1 mm (82-83), 0.5 mm (80-81), 1.0 mm (84-89).

It is, however, fairly improbable that *G. pulvillatus* is a troglobite. The type specimen shows no adaptations to cave life and no other oncopodids are so far known to live in caves. The animal was presumably collected from the leaf litter at the cave entrance or in the nearby rain forest.

*Remark:* 1 ♀ and 2 juv. specimens, reported from Ulu Gombak (just a few km away from the Batu Caves) and identified as *G. drescoi* by SUZUKI (1983), possibly also belong to *G. pulvillatus*. Both species are very similar in external morphology.

### ***Gnomulus drescoi* (Šilhavý, 1962)**

*Pelittus drescoi* Šilhavý (1962: 464-466, figs 1-9); description of ♀. - SUZUKI (1982: 186, figs 8-14); description of ♂, here considered conspecific with *G. armillatus*. - SCHWENDINGER (1992: 188, 197, figs 54-55).

*Gnomulus drescoi* (Šilhavý): MARTENS & SCHWENDINGER (1998: 526).

*Type:* SUMATRA. Dolok Banol or Telok Belong (ŠILHAVY 1962: 466) or Dolok Barol (ROEWER 1927: 268) (locality unknown), ♀ holotype (MHNP 24219, examined).

*Diagnosis:* Medium-sized species with elevated, conical eye tubercle; wide, indistinctly divided carapace-abdominal bridge; moderately elevated scutal areas; antero-proximal processes on ventral sides of coxae II and III distinct, posterior-

proximal process on ventral side of coxa II indistinct; small ventral processes on palpal trochanter and femur (ŠILHAVÝ 1962: figs 1-9).

*Remarks:* ♂ unknown. Šilhavý obviously compared his type specimen with ROEWER's (1923: 63, figs 66a-d) incorrect redescription and illustrations of "*G. segnipes*" (placed in synonymy with *G. armillatus* in here; see below). Had he examined ♀ specimens from close to the type locality of "*G. segnipes*", he might not have described *G. drescoi*.

The ♀ holotype of *G. drescoi* accords with ♀♀ of *G. armillatus* in all relevant characters (cf. ŠILHAVÝ 1962: 466). However, as the type locality of *G. drescoi* - and more importantly, the ♂ from the type locality - is not known, this species cannot be formally placed in synonymy with *G. armillatus*. Moreover, additional ♀♀ specimens were found near Medan (North Sumatra Province), which are similar to, but seemingly not conspecific with, ♀♀ of *G. armillatus*.

A ♂ from "Lumban, Gavn" (locality unknown; ZMC), identified as *G. drescoi* and illustrated by SUZUKI (1982: 186, figs 8-14), clearly belongs to *G. armillatus*.

*Relationships:* *Gnomulus drescoi* is very close to *G. armillatus*, possibly conspecific with it.

*Distribution:* Unknown; type locality not identified. The specimens recorded from Ulu Gombak (near Kuala Lumpur, Malaysia) by SUZUKI (1983), presumably belong to *G. pulvillatus* (see above).

### ***Gnomulus armillatus* (Thorell, 1891)**

Figs 108-134

*Pelitus armillatus* Thorell (1891: 758-759); description of juvenile. - LOMAN (1902: 182-183). - Roewer (1923: 63). - ROEWER (1927: 267-268, doubtful record from Penang Island). - SCHWENDINGER (1992: 197-198).

*Gnomulus armillatus* (Thorell): MARTENS & SCHWENDINGER (1998: 527).

*Pelitus segnipes* Loman (1893: 25-26, pl. 1, figs 13-15), **nov. syn.**; description of juvenile. - LOMAN (1902: 182-183, pl. 9, figs 20-21; 1903: figs P-e, Q-b); description of adults from allospecific (and conspecific?) specimens. - ROEWER (1923: 63, figs 66a-d); illustration of allospecific (and conspecific?) specimens. - ROEWER (1927: 267-268). - SCHWENDINGER (1992: 187, 197-198, figs 57-61); description of ♂ from allospecific specimen.

*Gnomulus segnipes* (Loman): MARTENS & SCHWENDINGER (1998: 526).

*Type:* SUMATRA, West Sumatra Province, Ajer Mancior (= Ajir Mancior = Ajer Mantjor = Ajer Mantjor), 360 m, ca. 7 km west of Padangpanjang, on the road from Padangpanjang to Padang, juvenile holotype (MSNG, examined), leg. O. Beccari, VI.1878.

*Other material:* SUMATRA, West Sumatra Province, Kajoetanam (= Kayutanam = Kaju Tanam), ca. 12 km southwest of Padangpanjang, juvenile holotype of "*G. segnipes*" (placed in synonymy with *G. armillatus* in here) (ZMA), leg. M. Weber. - Lumban, Gavn (locality unknown), 1500 m, 1 ♂ [ZMC; illustrated under *G. drescoi* by Suzuki (1982: 186, figs 8-14)], leg. O. Hagerup, XI.1916. - Fort de Cock in Bukittingi, 3 ♀ (SMF 300). - Anai (valley at the foot of Gunung Singgalang), 400-440 m, secondary forest, 1 ♂ (collection of C. Deeleman-Reinhold), leg. C. Deeleman-Reinhold, 10.-22.VI.1994. - Gunung Singgalang, 1500-1750 m, in grass, 1 ♂ (ZMT), leg. P. Lehtinen, 25.-27.IX.1978. - Padang (exact locality unknown), 1 ♂ (SMF 5754). - Jambi Province, Gunung Kerinci, lower montane forest, in leaf litter, 1 ♂ (NHML), leg. P. D. Hillyard, II.1985.

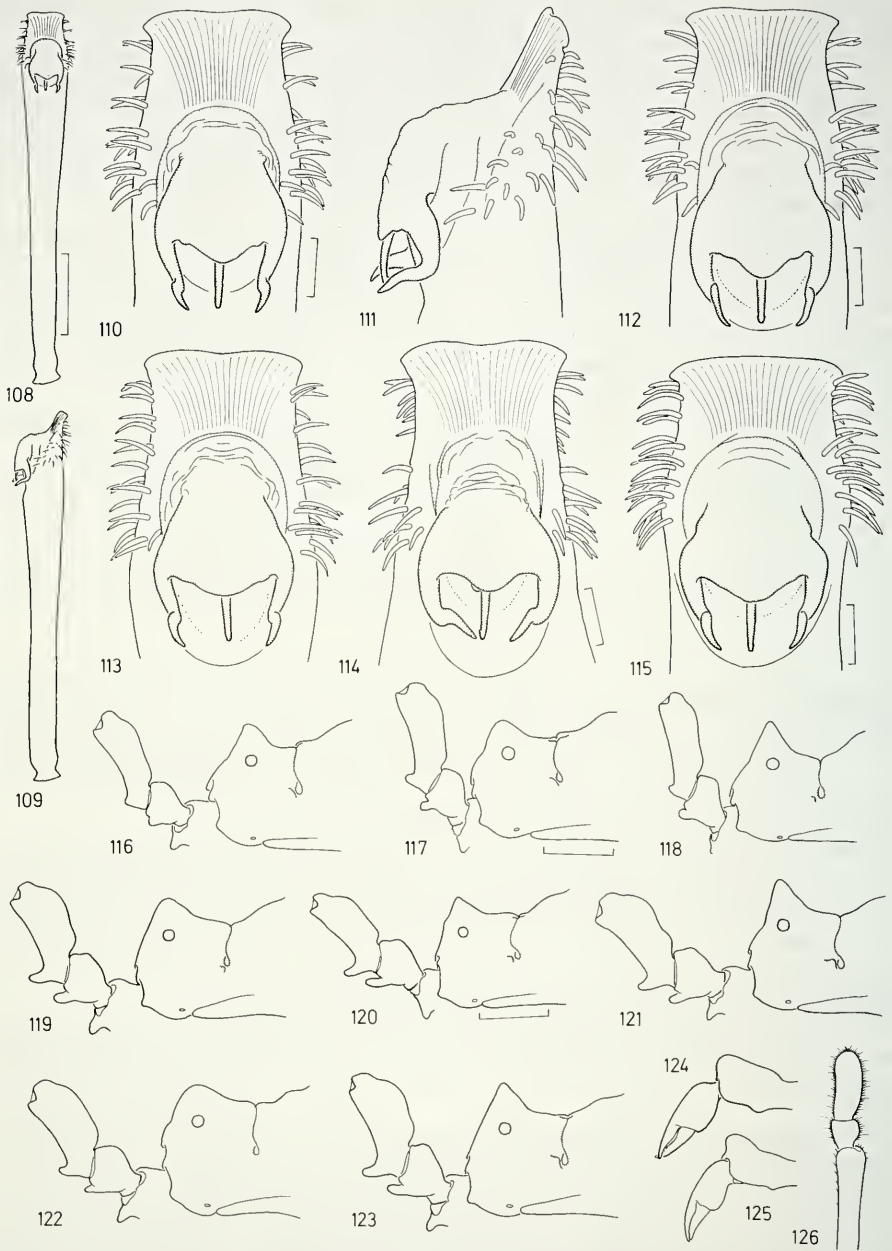

Figs 108-126

*Gnomulus armillatus* (Thorell). - Penis of ♂ from Padang, dorsal (108) and lateral view (109); apex of penis, dorsal (110) and lateral view (111); apex of penis, dorsal view, of ♂♂ from: Anai (112), Lumban (113), Gunung Singgalang (114, truncus penis dorso-ventrally collapsed



*Diagnosis:* Characterized by elevated, more or less pointed eye tubercle; lateral tubercles on posterior carapace small or absent (Figs 116-123); carapace-abdomen bridge wide, medially indistinctly divided or entire; scutal areas moderately elevated, ventral ones pale and swollen in ♂♂; distinct antero-lateral processes ventrally on coxa I, antero-proximal ones on coxae II and III, postero-proximal process on coxa II very indistinct or absent; chelicerae weak, proximal article slightly stronger in ♂♂ (Fig. 124), with dorso-distal boss and short, rounded ventro-median tubercle (Figs 124-125); ventral processes on palpal trochanter and femur strong in ♂♂ (Figs 119-123), generally weaker in ♀♀ (Figs 116-118); distitarsus of leg II ca. 2.7 times longer than wide (Fig. 126). Penis fairly slender, distal margin of truncus straight or slightly invaginated; glans penis with sigmoid, pointed lateral sclerites; median plate very widely V-shaped, covering membranous tubes; stylus slender (Figs 108-115).

*Variation:* Measurements (♂, in brackets ♀): body 5.53-6.09 (6.31-6.62) long, 3.90-4.51 (4.45-4.73) wide; carapace region 1.21-1.42 (1.17-1.21) long, 2.13-2.41 (2.29-2.41) wide; leg II (measured in its entirety) 11.07-12.29 (11.68-13.87) long; ♂ (n = 5), ♀ (n = 3). The juvenile type of *G. armillatus* (Figs 127-130; tarsi 1-1-2-2) has body length 1.91, width 1.80, the juvenile type of "*G. segnipēs*" (placed in synonymy with *G. armillatus* in here) (Figs 131-133; tarsi 2-2-2-2) 4.13 and 3.27 respectively.

Eye tubercle shapes in mature specimens vary from high and acutely pointed to fairly low and broadly rounded; the tubercle runs straight down to the carapace front margin or is separated from it by an indistinct step (Figs 116-123). The posterior part of the carapace-abdomen bridge is entire or medially divided by a small invagination. Lateral tubercles on posterior carapace are more or less distinct in the specimens from the north of the distribution area (Figs 116-121, 123) and absent in the one from the south (Fig. 122). Variation in penis morphology is small (Figs 110, 112-115). The penis in Fig. 114 is deformed (truncus collapsed at the height of the glans) and therefore appears different from the others.

In external characters, the ♂ from Gunung Kerinci (the most southern locality; Figs 115, 122) looks somewhat different from the other specimens examined but penis morphology shows conspecificity. Its low rounded eye tubercle (Fig. 122) is possibly due to individual variation and not to geographical variation. Quite different eye tubercle shapes are also seen in 3 ♀ from Fort de Cock (Figs 116-118).

External sexual dimorphism in *G. armillatus* is expressed in ♂♂ having a slightly stronger proximal cheliceral article (Fig. 124), longer ventral processes on their palps (Figs 119-123) and swollen ventral scutal areas.

*Remarks:* The juvenile types of *G. armillatus* (Figs 127-130) and of "*G. segnipēs*" (placed in synonymy with *G. armillatus* in here) (Figs 131-133) both show no distinctive characters, apart from an elevated, conical eye tubercle and a ventral

---

behind penis), Gunung Kerinci (115). Anterior body and proximal palp, lateral view. of: 3 ♀ from Fort de Cock, Bukittinggi (116-118), ♂ from Lumban (119), ♂ from Padang (120), ♂ from Anai (121), ♂ from Gunung Kerinci (122) and ♂ from Gunung Singgalang (123); left chelicera of ♂ (124) and of ♀ (125), retrolateral view; distal part of left leg II, retrolateral view (126). - Scale lines 0.1 mm (110-115), 0.5 mm (108-109), 1.0 mm (116-126).

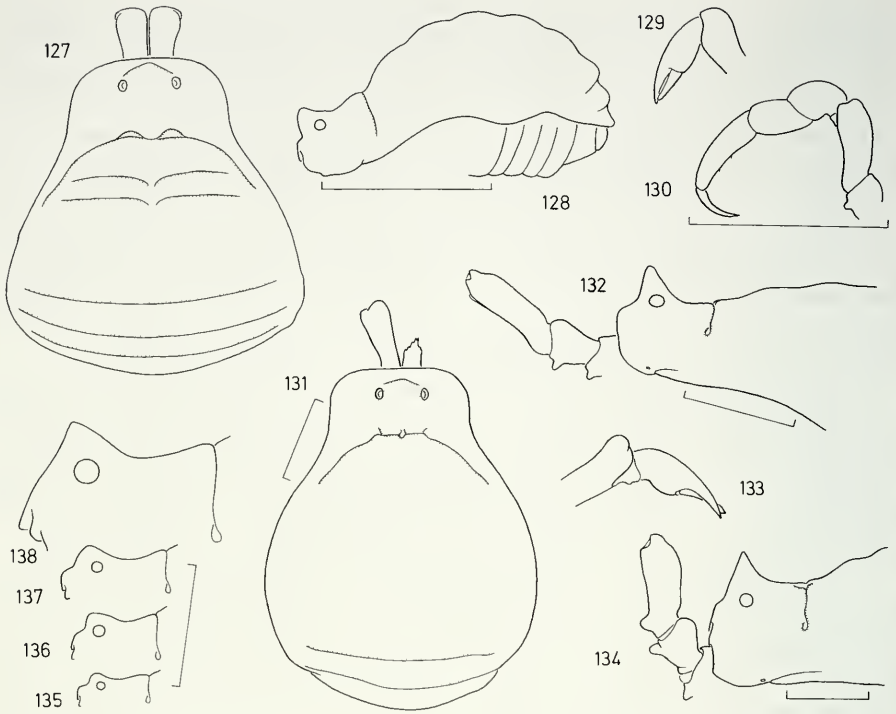

Figs 127-138

*Gnomulus armillatus* (Thorell) (127-134), *Gnomulus* sp. (135-138). - Juvenile holotype (1.91 mm long, tarsi 1-1-2-2), body, dorsal (127) and lateral view (128); left chelicera (129) and left palp (130), retrolateral view. Juvenile holotype of "*Gnomulus segnipes*" (= *G. armillatus*; 4.13 mm long, tarsi 2-2-2-2), body, dorsal view (131); anterior body and proximal palp, lateral view (132); left chelicera, prolateral view (133). Juvenile from Gunung Singgalang (5.31 mm long, tarsi 2-2-3-3), anterior body and proximal palp, lateral view (134). Eye tubercles in 3 juveniles (135-137) and 1 ♀ (138) of an undescribed species from Aceh, Sumatra, lateral view. - Scale lines 1.0 mm.

process on palpal trochanter. This, however, is also present in many other *Gnomulus* species. Additional characters, which were previously considered significant [i.e. eye tubercle clearly set back from carapace front margin (thus forming a distinct clypeus) and palpal femur without ventro-proximal process], appear to be juvenile character states which change during postembryonic development.

In all available juveniles of *Gnomulus* species which possess a conical eye tubercle, this is small and set back from the carapace front margin in early instars. As the animals grow, the eye tubercle becomes larger and its base usually extends to the carapace front margin, in the course of which the clypeus disappears. These gradual changes in 3 juveniles (of different size) and 1 ♀ of an undescribed species from the northern part of Sumatra are illustrated in Figs 135-138 (see also Fig. 134, showing a large *G. armillatus* juvenile).

In small juveniles the ventro-proximal process on the palpal femur is a low dome, which (together with a small wart-like process on palpal trochanter) becomes increasingly prominent during postembryonic development. Three steps of this development in juveniles of *G. armillatus* are illustrated in Figs 130, 132 and 134.

The types of *G. armillatus* and "*G. segnipes*" and the mature specimens that we attribute to this species are all very similar to each other (juvenile characters taken into account) and they originate from the same area in western Sumatra. Although this area has been relatively well sampled for oncopodids since 1878, no other congeneric species were collected there, apart from the very distinct (even in juveniles) *G. sumatranus*. We consider this as a sufficient reason for placing "*G. segnipes*" in synonymy with *G. armillatus* and to attribute them to mature specimens from the same area. By doing so, two of the most doubtful oncopodid species can be united and placed on a satisfactory taxonomic basis.

Much confusion about the identity of "*G. segnipes*" (placed in synonymy with *G. armillatus* in here) was caused by Roewer's redescription and illustrations (ROEWER 1923: 63, figs 66a-d), which were mostly based on a ♂ specimen from Bandjermasin (= Banjarmasin in southern Kalimantan). Among the specimens Roewer examined and considered conspecific, unfortunately this one is morphologically and geographically most distant to the type. Penis morphology now clearly shows that this ♂ is distinct from *G. armillatus*; it will be formally described as a new species in our subsequent paper.

Misguided by Roewer's unlucky choice of a representative for "*G. segnipes*", SCHWENDINGER (1992: 187, figs 62-66) incorrectly (but with reservation) described the male of this species from the Bandjermasin specimen. Moreover, it seemingly also led to the controversial description of *G. drescoi* by ŠILHAVÝ (1962; discussion see above) and to an incorrect distinction between "*G. segnipes*" and *G. drescoi* by SUZUKI (1977: table 3).

It also appears that ROEWER (1923: 63) took the characters for his distinction of "*G. segnipes*" from at least two specimens from outside Sumatra, which belong to different species. His figure 66b obviously refers to the ♂ from Banjarmasin, whereas the median furrow between areas I-III in fig. 66a (between areas I-IV given in the corresponding text) is not visible in the Banjarmasin specimen but in the ones from Telang or Talang (locality unknown), Borneo and from Mt. Gede, Java instead. None of the specimens mentioned have an eye tubercle as distinctly set back from the carapace front margin as shown by ROEWER (1923: fig. 66c).

One of Roewer's diagnostic characters is non-existent: "4. Coxa dorsal apical lateral mit 1 stumpfen Dorn" (coxa IV dorsally with a blunt disto-lateral spur; ROEWER 1923: 63, fig 66a, also referred to by SUZUKI 1977: table 3). This is neither present in any of the specimens from Roewer's collection (now in SMF), nor in any other *Gnomulus* specimens examined. He seemingly had confused the upper part of two opposing distal spurs, which occur pro- and retrolaterally on all leg coxae of all oncopodid species, with a single dorsal spur.

*Relationships:* *Gnomulus armillatus* is close to *G. drescoi* from Sumatra (possibly conspecific) and to *G. piliger* and *G. pulvillatus* from peninsular Malaysia.

*Distribution:* Known from the surroundings of Bukittinggi and Padang in West Sumatra Province and from Gunung Kerinci at the border between the provinces of West Sumatra and Jambi (Fig. 1). The type locality, Ajer Mancior (THORELL 1891: 95), is a waterfall located in the Lembah Anai Nature Reserve, in the Anai Valley, near Gunung Singgalang (BECCARI 1930: 581; LOOSE 1996: 240).

The male specimen collected by O. Hagerup at "Lumban, Gavn" (locality not identified) and reported by SUZUKI (1982: 186) is accompanied by a hand-written (probably by Suzuki) label, which reads "Lumban Gavn". This could possibly correspond with "Lumban Gaol", a village near Balige, at the southern end of Lake Toba, in Northern Sumatra Province, about 340 km north of the type locality. However, according to information by Dr Ib Friis from the Botanical Museum in Copenhagen where Hagerup was working (N. Scharff, personal communication), the locality in question is possibly situated in the "Padang Highlands".

Previous records of "*G. segnipes*" from Java and Borneo (LOMAN 1902: 182; ROEWER 1923: 63) belong to different, yet undescribed species (see also SCHWENDINGER 1992: 187, 197-198). The record of *G. armillatus* from Penang Island by ROEWER (1927: 268; specimen in Museum Calcutta, not examined) is most doubtful, since he also has misidentified a *G. rostratus* ♀ from the same locality for a "*G. segnipes*" ♂ (see above). *Gnomulus armillatus* hence appears to have a fairly small distribution area, as it is the case in all other oncopodid species (also to be shown for *Oncopus*).

### ***Gnomulus thorelli*** (Sørensen, 1932)

Figs 139-143

*Pelitus thorelli* Sørensen (1932: 213-215); description of species, without distinction of sexes. Not *P. thorelli* Schwendinger (1992: 180-182, 197, figs 14-26).

*Gnomulus thorelli* (Sørensen): MARTENS & SCHWENDINGER (1998: 527).

*Types:* JAVA, without locality, 2 ♀ syntypes (both with missing ovipositor; ZMC examined), ded. E. Simon, "M. 27.VI.1898".

*Other material:* JAVA, Tjibodas (= Cibodas, near Bogor), 1400 m, 1 juv. (AMNH), leg. Dammernann, V.1922.

*Diagnosis:* Medium-sized species with moderately elevated, conical eye tubercle; small lateral tubercles present on posterior carapace (Figs 140-141); carapace-abdomen bridge wide, indistinctly divided (Fig. 139); scutal areas slightly elevated; antero-lateral process on coxa I and anterior-proximal process on coxa II distinct, postero-lateral one on coxa II and antero-lateral one on coxa III indistinct; chelicerae weak, proximal article with dorso-distal boss, no ventral tubercle (Fig. 142); palp with small, knob-shaped process ventrally on trochanter; ventral process on palpal femur short and slightly distad-inclined, distinctly remote from proximal margin (Figs 140-141); distitarsus II about 2.5 times longer than wide (Fig. 143).

*Variation:* Measurements of both ♀♀: body 6.42-6.67 long, 4.30-4.46 wide; carapace region 1.18-1.25 long, 2.21-2.24 wide; leg II (measured in its entirety) 9.60-10.03 long. The eye tubercle in one ♀ (Fig. 141) is distinctly more pointed than in the other (Fig. 140).

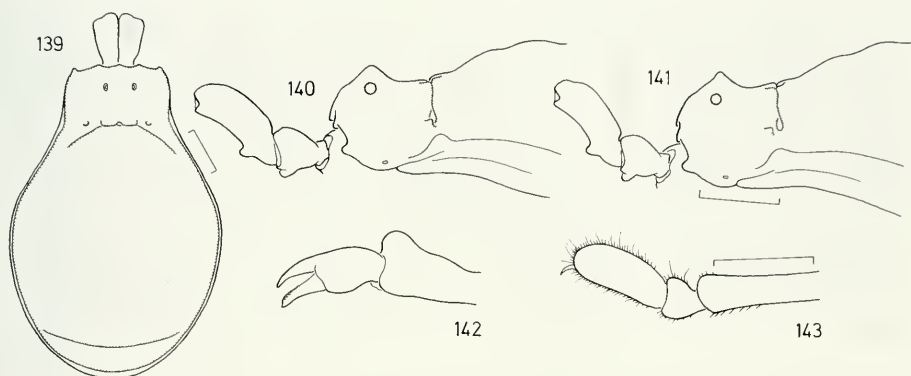

FIGS 139-143

*Gnomulus thorelli* (Sørensen). - Body and chelicerae of ♀ syntype, dorsal view (139); anterior body and proximal palp of first ♀ syntype (140) and of second ♀ syntype (141), lateral view; left chelicera (142) and distal part of left leg II (143), retrolateral view. - Scale lines 1.0 mm.

*Remarks:* ♂ unknown. Three other specimens from Java are available, which clearly differ from *G. thorelli* in palpal armament and eye tubercle shape. One of them is a ♂ from Mt. Gede (near Cibodas; ZMH), identified as "*G. segnipes*" (placed in synonymy with *G. armillatus* in here) by LOMAN (1902: 182) and ROEWER (1923: 63). The others are 2 ♀ (without exact locality; SMF), labeled by Roewer in 1929 as "*Pelitnus javanus* n. sp., Typus". For all we know, such a species has neither been described, nor was it ever mentioned in the literature. These specimens will be described in our next paper.

*Relationships:* From external characters *G. thorelli* appears closest to the unnamed ♂ from Banjarmasin (Southern Kalimantan), which was previously misidentified as "*G. segnipes*".

*Distribution:* The exact type locality is unknown but the find of a conspecific juvenile (with typical sub-proximal, distad-inclined process on ventral femur) indicates that *G. thorelli* occurs in the mountains southeast of Bogor, western Java (Fig. 1).

### *Gnomulus laevis* (Roewer, 1915)

Figs 144-158

*Pelitnus laevis* Roewer (1915: 128, fig. 72); description of species, without distinction of sexes.  
- ROEWER (1923: 64, fig. 67). - SCHWENDINGER (1992: 188-190, 197, figs 62-66); description of ♂.

*Gnomulus laevis* (Roewer): MARTENS & SCHWENDINGER (1998: 526).

*Types:* BORNEO, Mt. Tiloeng (on Roewer's label: "Tilung Berg") (locality unknown, probably in Sarawak), 2 ♀ syntypes (SMF 1260, examined).

*Other material:* BORNEO, without locality, 1 ♂ [illustrated by Schwendinger (1992: figs 62-66); MHNG]; SARAWAK, Kuching, 1 ♂ (AMNH), leg. Krishna, 4.IV.1978; Mt. Matang (= Gunung Serapi, near Matang, west of Kuching), 2 ♀ (AMNH), leg. Mjöberg.

*Diagnosis:* Distinguished by palpal femur without distinct ventro-basal process (at best represented by a low rounded hump) (Figs 148, 152-154) but with a pro-

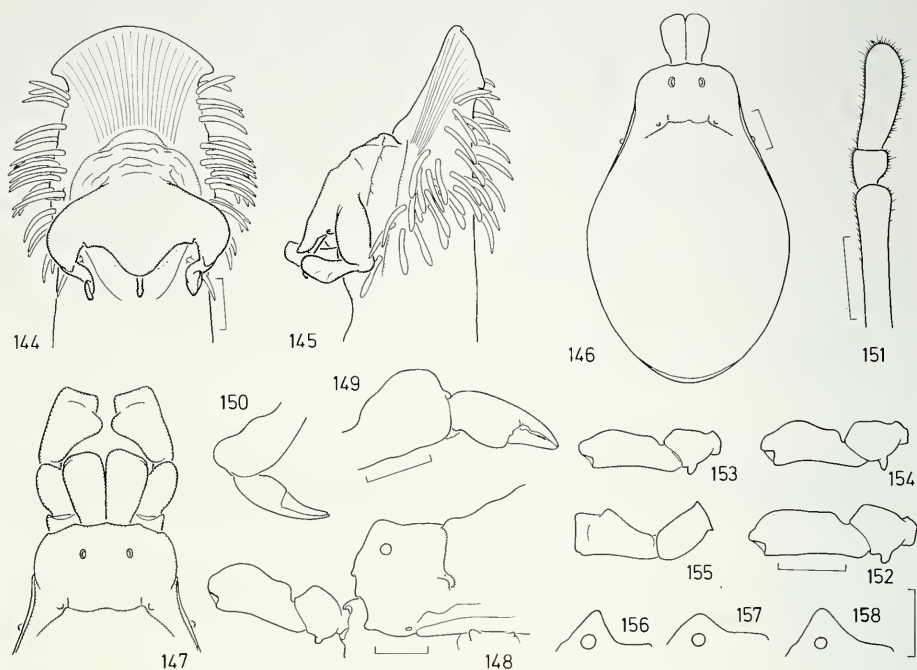

Figs 144-158

*Gnomulus laevis* (Roewer). ♀ syntype (146, 150, 154-156). - Apex of penis, dorsal (144) and lateral view (145). Body and chelicerae, dorsal view (146); anterior body, chelicerae and proximal palp of ♂ from Kuching, dorsal view (147), the same (without chelicera), lateral view (148); right chelicera of ♂ (149) and of ♀ (150), retrolateral view; distal part of left leg II, retrolateral view (151); trochanter and femur of left palp of ♂ (152) and of 2 ♀ (153-154), lateral view, the same of ♀, dorsal view (155); eye tubercles of 2 ♀ (156-157) and of ♂ from "Borneo" (158), lateral view. - Scale lines 0.1 mm (144-145), 1.0 mm (146-158).

dorsal, median boss (Figs 147, 155); ventral process on palpal trochanter peg-like (Figs 148, 152-154); proximal article of chelicerae with dorso-distal and dorso-median bosses, hand slender (Figs 149-150); distitarsus of leg II about 2.9 times longer than wide (Fig. 151); dorsal side of leg coxa IV with two small tubercles below lateral margin of dorsal scutum (Fig. 148); eye tubercle more or less raised and conical (Figs 148, 156-158); carapace-abdomen bridge wide, composed of a pair of slightly recurved lobes (Figs 146-147); small lateral tubercles on posterior carapace present (Figs 146-148); dorsal scutal areas only slightly elevated; coxa I ventrally with small antero-lateral process, coxa II with antero- and postero-proximal processes, the latter overlapping antero-proximal process on coxa III. External sexual dimorphism in: ♂♂ with stronger proximal article of chelicerae (Fig. 149), more developed prodorsal boss on palpal femur (Fig. 147) and pale, swollen ventral scutal areas. Penis fairly slender, apex of truncus carrying plenty of lateral setae from tip to below glans; distal margin of truncus penis broadly arched; glans short, wider than

truncus; lateral sclerites strongly convex laterally, their tips paddle-shaped, pointing away from the truncus; median plate rounded, with lateral teeth, covering membranous tubes; stylus slender (Figs 144-145; see also SCHWENDINGER 1992: figs 63-66).

*Variation:* Measurements ( $\delta$ , in brackets  $\text{♀}$ ): body 6.91-7.88 (6.94-7.88) long, 4.63-5.25 (4.63-5.13) wide; carapace region 1.44-1.75 (1.34-1.53) long, 2.59-2.94 (2.41-2.66) wide; leg II (measured in its entirety) 14.52-15.08 (12.36-14.58) long;  $\delta$  (n = 2),  $\text{♀}$  (n = 4). The eye tubercle is high and pointed in one  $\text{♀}$  syntype (Fig. 156) and low and rounded in the  $\delta$  from Kuching (Fig. 148); the other specimens are intermediate (Figs 157-158). The second  $\text{♀}$  syntype and one  $\text{♀}$  from Mt. Matang have a narrowly rounded posterior margin on the dorsal scutum, making the body appear almost elliptical (Fig. 146); in the other specimens the dorsal scutum is more rounded behind.

*Relationships:* In penis morphology, *G. laevis* is more similar to the unnamed  $\delta$  from Banjarmasin, Kalimantan (SCHWENDINGER 1992: figs 58-61, sub "*G. segnipes*") than to the sympatric *G. sundaicus*.

*Distribution:* Known from the surroundings of Kuching, Sarawak (Fig. 1). The type locality, Mt. Tiloeng or Mt. Tilung, however, remains unknown. There is a Mt. (Gunung) Tilong, mentioned by BECCARI (1904: 254, 303), which apparently is one of the major mountains between Sarawak and Kalimantan ["... in the interior from which the principal rivers in Borneo flow."]. This, however, would be in the central part of Borneo, quite far away from Kuching, and therefore may not correspond with the type locality of *G. laevis*.

### **Gnomulus sundaicus** (Schwendinger, 1992)

Figs 159-160

*Pelitus sundaicus* Schwendinger (1992: 185-187, 197, figs 42-53); description of  $\delta$  and  $\text{♀}$ .

*Gnomulus sundaicus* (Schwendinger): MARTENS & SCHWENDINGER (1998: 527).

*Types:* SARAWAK, environs of Bau, Serian and Kuching, 10-50 m,  $\delta$  holotype, 2  $\delta$ , 2  $\text{♀}$  paratypes (MHNG, examined), leg. C. Lienhard, 3.-13.XII.1987.

*Other material:* BORNEO, Mus Twin (locality unknown), 1  $\delta$  (with label: "*Pelitus modestus* n. sp.", ZMC); SARAWAK, without exact locality, 1  $\text{♀}$  (SMF 5336, det. *Pelitus laevis* by Roewer in 1935).

*Remarks:* "*Pelitus modestus*" has never been described (collection name). The penis of this specimen (Figs 159-160) clearly shows that it belongs to *G. sundaicus* (cf. SCHWENDINGER 1992: figs 48-53).

*Relationships:* Externally *G. arnillatus* resembles the long-legged *G. annulipes*, whereas from penis morphology it appears closer to *G. arnillatus*.

*Distribution:* Known from the area south of Kuching, western Sarawak (Fig. 1).

### **Gnomulus annulipes** (Pocock, 1897)

Figs 161-171

*Pelitus annulipes* Pocock (1897: 283-285); description of species, without distinction of sexes. - ROEWER (1923: 63-64). - SCHWENDINGER (1992: 188, 197, fig. 56).

*Gnomulus annulipes* (Pocock): MARTENS & SCHWENDINGER (1998: 527).

*Type:* SARAWAK, Baram,  $\text{♀}$  holotype (NHML, examined), leg. C. Hose.

*Other material:* Baram River, 1  $\text{♀}$  (SMF 5103, det. "*Pelitus segnipes*" by Roewer in 1932); Gunung Mulu National Park, Pinnacle Camp (Camp 5), 1200 m. limestone scrub, 1  $\delta$  (NHML), leg. F. Wanless, 29.V.1978.

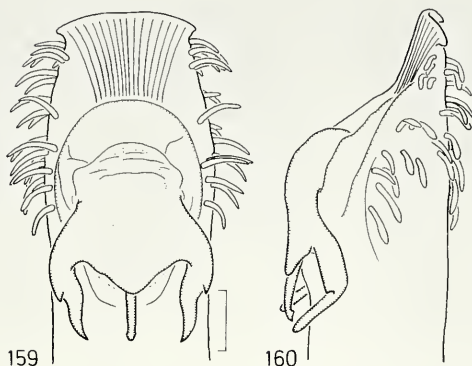

FIGS 159-160

*Gnomulus sundaicus* (Schwendinger), ♂ specimen from ZMC, labeled "*Pelitus modestus*". - Apex of penis, dorsal (159) and lateral view (160). - Scale line 0.1 mm.

*Diagnosis:* Characterized by a narrow, more or less distinctly elevated, slightly forward-inclined eye tubercle (Figs 166-168); carapace-abdomen bridge wide, subdivision indistinct (Fig. 165); lateral tubercles on posterior carapace present; dorsal scutal areas markedly elevated; ventro-proximal process on palpal femur more or less distinct, ventral process on trochanter peg-like (Figs 166-168); proximal article of chelicerae with dorso-distal and dorso-median boss, hand slender (Figs 169-170); legs quite long; distitarsus of leg II 3.4-3.9 times as long as wide (Fig. 171); coxa I ventrally with distinct antero-lateral process, coxa II with antero- and postero-proximal processes, coxa III with indistinct antero-proximal one. External sexual dimorphism in: ♂ with a stronger proximal cheliceral article (Fig. 169), with proximal tarsalia on legs III and IV distinctly wider than distal one and with pale, swollen ventral scutal areas. Penis fairly slender, truncus constricted at height of glans, distal margin only slightly arched and medially invaginated, apex with plenty of lateral setae (not reaching below glans); lateral sclerites of glans with dorsal margins elevated above median plate, tips of sclerites drawn into small sigmoid hooks; median plate widely V-shaped, covering short membraneous tubes; stylus slender (Figs 161-164).

*Variation:* Measurements (♂, in brackets ♀): body 7.35 (6.73, holotype 7.03) long, 4.86 (4.68) wide; carapace region 1.49 (1.28) long, 2.62 (2.40) wide; leg II (measured in its entirety) 17.36 (15.00) long; ♂ (n = 1), ♀ (n = 2). Variation in the shape of the eye tubercle, see Figs 166-168. The tubercle on the right side of the posterior carapace of the ♀ holotype is unusually large (Fig. 167); on its left side it is of the same size as in the other specimens (see Figs 166, 168). In the 2 ♀ examined, the carapace-abdomen bridge is more distinctly divided than in the ♂ (Fig. 165). The ♂ has a smaller proximal process ventrally on its palpal femur (Fig. 166) and a much larger antero-lateral process ventrally on its coxa I than the ♀♀. This is more likely due to individual variation than to sexual dimorphism.



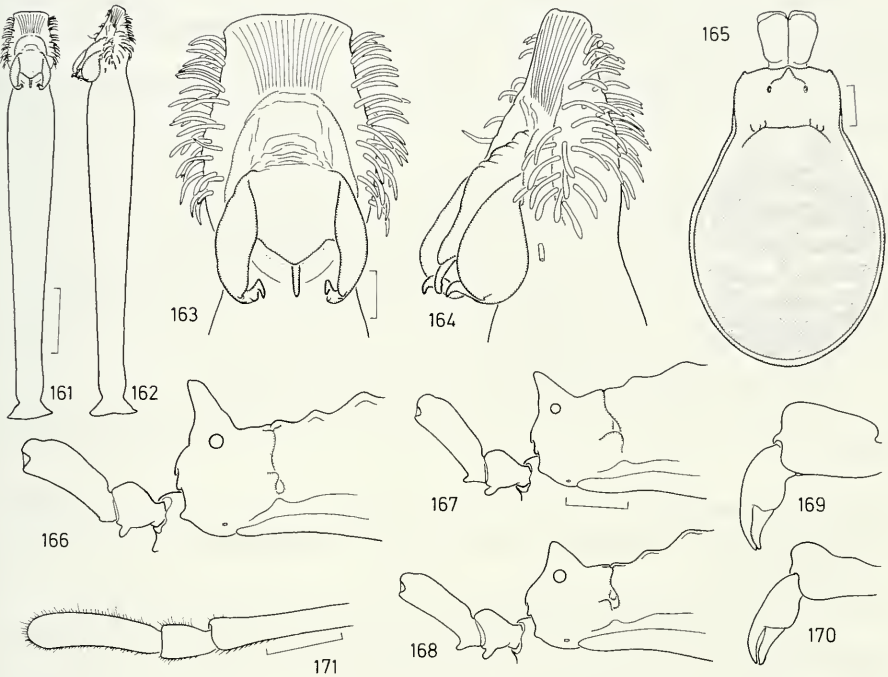

FIGS 161-171

*Gnomulus annulipes* (Pocock), ♀ holotypus (167, 170). - Penis, dorsal view (161) and lateral view (162); apex of penis, dorsal view (163) and lateral view (164). Body and chelicerae of ♂, dorsal view (165); anterior body and proximal palp of ♂ (166) and of 2 ♀ (167-168), lateral view; left chelicera of ♂ (169) and of ♀ (170), retrolateral view; distal part of left leg II, retrolateral view (171). - Scale lines 0.1 mm (163-164), 0.5 mm (161-162), 1.0 mm (165-171).

*Relationships*: This species is close to congeners from Borneo. Its penis is most similar to that of an undescribed species from eastern Sarawak and Sabah, which will be described in our next paper.

*Distribution*: Known from the catchment area of the river Baram, northeastern Sarawak, near the border to Brunei (Fig. 1).

### *Gnomulus baharu* Schwendinger, 1998

*Pelitus thorelli* Schwendinger (1992: 180-182, figs 14-26, pl. 1); description of ♂ and ♀. Not *P. thorelli* Sørensen, 1932: 213-215.

*Gnomulus baharu* Schwendinger in MARTENS & SCHWENDINGER (1998: 527); transferred from "*Pelitus*" and renamed because of homonymy.

*Types*: BRUNEI, Andulau Forest Reserve and Sungai Lubang Barus, ♂ holotype, 1 ♂, 1 ♀ paratypes (MHNG, examined), leg. B. Hauser, 16./26.XI.1988.

*Remark:* No new material available.

*Relationships:* This species is close to *G. conigerus* and probably also to *G. palawanensis* (♂ unknown).

*Distribution:* Known from the area west of Bandar Seri Begawan, western Brunei (Fig. 1).

### **Gnomulus conigerus** (Schwendinger, 1992)

*Pelitus conigerus* Schwendinger (1992: 183, 197, figs 27-41); description of ♂.  
*Gnomulus conigerus* (Schwendinger): MARTENS & SCHWENDINGER (1998: 527).

*Types:* SABAH, Kabili-Sepilok Forest Reserve and Kolapis, both near Sandakan, 30-60 m, ♂ holotype, 1 ♂, 1 juv. paratypes (MHNG, examined), leg. B. Hauser, 12.III.1983.

*Remark:* No new material available.

*Relationships:* *Gnomulus conigerus* is closest to *G. baharu*.

*Distribution:* Known from the area north of the Sandakan Bay, eastern Sabah (Fig. 1).

### **Gnomulus palawanensis** (Suzuki, 1982)

*Pelitus palawanensis* Suzuki (1982: 184-186, figs 1-7); description of ♀. - Schwendinger (1992: 198).

*Gnomulus palawanensis* (Suzuki): MARTENS & SCHWENDINGER (1998: 527).

*Type:* PHILIPPINES, Palawan, Mt. Mantalingajan, 1150 m, west of Brooke's Point, ♀ holotype (ZMC, not examined), leg. Noona Dan Expedition, 15.IX.1961.

*Remark:* No new material available; ♂ unknown.

*Relationships:* According to external morphology, *G. palawanensis* is closest to *G. baharu* and *G. conigerus*.

*Distribution:* Known only from a mountain in the southwest of Palawan Island (Fig. 1).

### THE GOODNIGHT-GROUP

*Diagnosis:* Small species with low, rounded or conical, pointed eye tubercles; penes with more or less distinctly enlarged stylus.

This group comprises six species from the Philippines and one (assignment uncertain) from northern Borneo.

### **Gnomulus imadatei** (Suzuki, 1969)

*Pelitus imadatei* Suzuki (1969: 12-16, figs 1-4); description of ♂. - SCHWENDINGER (1992: 197).

*Gnomulus imadatei* (Suzuki): MARTENS & SCHWENDINGER (1998: 526).

*Type:* BRUNEI, Amo (= Sungai Amoh), ♂ holotype (Zoological Laboratory, University of Hiroshima, not examined), leg. G. Imadaté, 24.II.1962.

*Remark:* No new material available.

*Relationships:* Small size (3.77 mm body length) and a seemingly slightly enlarged stylus (SUZUKI 1969: fig. 4d) indicate close relationship with *G. goodnighti* and other species from the Philippines.

*Distribution:* Known only from the type locality, about 40 km southeast of Bandar Seri Begawan, eastern Brunei (Fig. 1).

***Gnomulus maculatus* Martens & Schwendinger, 1998**

*Gnomulus maculatus* Martens & Schwendinger (1998: 530-533, figs 82-89); description of ♂ and ♀.

*Types:* PHILIPPINES, Luzon, environs of Sagada, and a doubtful record from Puerto Galera, Mindoro, ♂ holotype (MHNG, examined), 1 ♂, 2 ♀ paratypes (MAR, MHNG, examined), leg. L. Deharveng, 21.XII.1979-9.I.1980.

*Remark:* No new material available.

*Relationships:* This species is externally similar to *G. goodnighti* but internally distinct by a penis with tongue-shaped median plate and markedly enlarged, bifid stylus.

*Distribution:* Known from the area around Sagada, in the central Cordilleras of northern Luzon (Fig. 1).

***Gnomulus coniceps* Martens & Schwendinger, 1998**

*Gnomulus coniceps* Martens & Schwendinger (1998: 533-536, figs 90-96); description of ♂.

*Type:* PHILIPPINES, Luzon, environs of Crystal Caves near Baguio, 1500 m. ♂ holotype (MHNG, examined), leg. L. Deharveng, 12.I.1980.

*Remark:* No new material available.

*Relationships:* The penis of *G. coniceps* superficially resembles that of *G. rostratus* and *G. insularis*, but its slightly enlarged stylus and various external characters point towards a close relationship with other congeners from the Philippines.

*Distribution:* Known only from the mountains north of Baguio, northern Luzon (Fig. 1).

***Gnomulus crucifer* Martens & Schwendinger, 1998**

*Gnomulus crucifer* Martens & Schwendinger (1998: 527-530, figs 71-81); description of ♂.

*Type:* PHILIPPINES, Luzon, Mt. Santo Thomas near Baguio, 1850 m, ♂ holotype (MHNG, examined), leg. L. Deharveng, 14.I.1980.

*Remark:* No new material available.

*Relationships:* *Gnomulus crucifer* is unusual in its genital and external morphology. Congruence in tarsal formula (2-2-2-2) with *G. laruticus* is obviously convergent. The strongly enlarged and modified stylus penis shows relationship with other species of the *goodnighti*-group.

*Distribution:* Known only from a mountain south of Baguio, northern Luzon (Fig. 1).

***Gnomulus minor* Tsurusaki, 1990**

*Gnomulus minor* Tsurusaki (1990: 59-62, figs 1-14); description of ♀. - SCHWENDINGER (1992: 198). - MARTENS & SCHWENDINGER (1998: 527).

*Type:* PHILIPPINES, Luzon, Laguna Province, Los Baños, Mt. Maquilin (= Mt. Makiling), ♀ holotype (National Science Museum, Tokyo, not examined), leg. R. Morse, 10.VI.1966.

*Remark:* No new material available. A similar, yet undescribed species with peculiar penis morphology occurs at the same locality.

*Relationships:* In external morphology *G. minor* accords with congeners from the Philippines.

*Distribution:* Known only from the type locality, south of Lake Laguna de Bay, central Luzon (Fig. 1).

### **Gnomulus leyteensis** Martens & Schwendinger, 1998

*Gnomulus leyteensis* Martens & Schwendinger (1998: 536-539, figs 97-104); description of ♂.

*Type:* PHILIPPINES, Leyte, Visca near Baybay, 200-500 m, ♂ holotype (MHNG, examined), leg. Martens & Schawaller, 10.III.1991.

*Remark:* No new material available.

*Relationships:* In external and genital morphology this species most closely resembles *G. goodnighti*.

*Distribution:* Known from the mountainous area close to the west coast of southern Leyte (Fig. 1).

### **Gnomulus goodnighti** (Suzuki, 1977)

Figs 172-178

*Pelitus goodnighti* Suzuki (1977: 9-12); description of ♂ and ♀. - SCHWENDINGER (1992: 196, 198).

*Gnomulus goodnighti* (Suzuki): MARTENS & SCHWENDINGER (1998: 526).

*Types:* PHILIPPINES, Mindanao, Davao Province, Mt. McKinley (close to Mt. Apo, east of Davao City), 2520 m. collected from tree ferns in a mossy forest, ♂ holotype, 1 ♂, 1 ♀ paratypes (Chicago Field Museum of Natural History; not examined), leg. H. Hoogstraal & D. Heyneman, 9.XI.1946.

*Other material:* PHILIPPINES, Mindanao, Bukidnon, Mt. Katanglad, 1480 m, ca. 15 km east of Malaybalay, 2 ♂ (Bishop Museum, Honolulu), leg. L. Quate & C. Yoshimoto, 27.-31.X.1959.

*Diagnosis:* Small species with low, widely conical eye tubercle (Figs 176-177); carapace-abdomen bridge formed by two opposing pairs of pointed processes; dorsal scutal areas elevated, with paramedian pairs of small tubercles in areas II-VII (Fig. 175); chelicerae very weak and slender; palp with fairly short femur bearing a small conical ventro-basal process; palpal trochanter ventrally with strongly distad-inclined process (Figs 176-177); distitarsus II 2.3-2.4 times longer than wide, densely covered by fine curved hairs dorsally (Fig. 178); coxa I ventrally with broadly rounded antero-lateral process, coxa II with distinct conical antero- and posterior-proximal processes, coxa III with indistinct antero-proximal one. No external sexual dimorphism apparent. Penis with distinctly invaginated distal margin; lateral sclerites of glans with long pointed tips (bearing denticles on the lower side) bent towards each other and away from the truncus; dorsal margins of lateral sclerites elevated above short, widely W- or U-shaped median plate; membraneous tubes large, distal part not

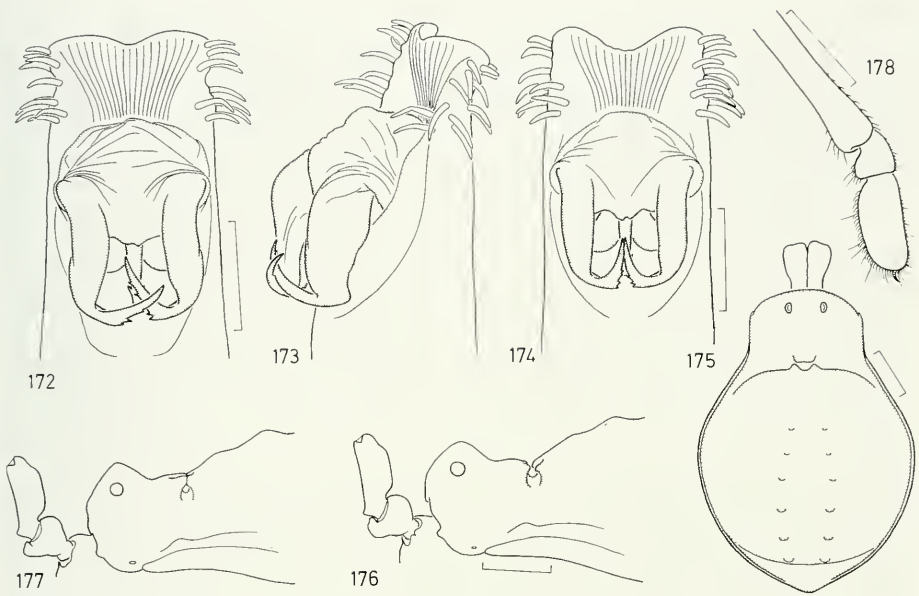

FIGS 172-178

*Gnomulus goodnighti* (Suzuki). - Apex of penis, dorsal (172) and lateral view (173); apex of penis of other ♂, dorsal view (174). Body and chelicerae, dorsal view (175); anterior body and proximal palp of 2 ♂, lateral view (176-177); distal part of left leg II, retrolateral view (178). - Scale lines 0.1 mm (172-174), 1.0 mm (175-178).

covered by median plate: stylus markedly incrassate (Figs 172-174, see also SUZUKI 1977: fig. 2f-i).

**Variation:** Measurements [♂, in brackets ♀; measurements of ♂ holotype (paratype?) and ♀ paratype taken from SUZUKI (1977: 9)]: body 2.91-3.27 (3.34) long, 2.13-2.38 (2.41) wide; leg II (measured in its entirety) 5.13-5.16 (5.14) long; ♂ (n = 3), ♀ (n = 1). Variation in the shape of eye tubercles and palpal processes is illustrated in Figs 176-177, variation in glans structures in Figs 172, 174. One ♂ has its carapace-abdomen bridge (usually formed by two opposing pairs of teeth touching each other at their tips) not closed (Fig. 176). In contrast to the type illustrated by SUZUKI (1977: fig. 1a, b), the specimens examined have a dorsal scutum with a more pointed posterior margin (Fig. 175) and a longer genital operculum.

**Remark:** Unlike in larger *Gnomulus* species, *G. goodnighti* ♂♂ have no swollen ventral scutal elevations and also their proximal cheliceral article seems to be indistinguishable from that of the ♀ (SUZUKI 1977: 12).

**Relationships:** *Gnomulus goodnighti* is closest to *G. leyteensis*. A close relationship between "*G. segnipes*" (placed in synonymy with *G. armillatus* in here) and *G. drescoi* on one hand and *G. goodnighti* on the other, as suggested by SUZUKI (1977: 6, 12), is not apparent.

**Distribution:** Known from two mountains in Davao and Bukidnon Province on Mindanao Island (Fig. 1).

## DISCUSSION

Most *Gnomulus* species described before 1998 correspond with the definition of "*Pelitus*" (placed in synonymy with *Gnomulus* by MARTENS & SCHWENDINGER 1998: 526) sensu THORELL (1891: 93), LOMAN (1902: 182), ROEWER (1923: 62) and SØRENSEN (1932: 213). They are mostly 5.5-8 mm long, possess a conical, more or less elevated eye tubercle and the tarsal formula 2-2-3-3.

There were only few exceptions to this. *Gnomulus imadatei* is the first small species (3.8 mm) described in this genus. The second small species, *G. minor* (3.4 mm), is unusual in completely lacking an eye tubercle. However, as this species is known only from a single ♀, its generic placement has yet to be confirmed by ♂♂. *Gnomulus sumatranus*, on the other hand, stands apart by its large size (almost 9 mm long) and by the presence of keeled dorsal scutal elevations, which in *Gnomulus* is otherwise only found in the undescribed ♂ from Bandjermasin and in *G. sundaicus* (larger but less acute). In general appearance *G. sumatranus* resembles species in the genus *Oncopus*, but tarsal formula (2-2-3-3) and penis morphology prove that it belongs in *Gnomulus*. Although at present no major distinctions in penis morphology between *Gnomulus* and *Oncopus* are known (but both genera clearly differ externally), the penis of *G. sumatranus* is unquestionably a typical *Gnomulus* penis, very similar to those of congeners from the same geographic region.

The remaining deviating species are *Gnomulus rostratus* and *G. insularis* (both about 6 mm long). They are readily distinguishable from all other congeners by a strongly antero-inclined eye tubercle and a unique penis morphology. Particularly in the shape of the stylus (Fig. 69c-e), the penes of *G. rostratus* and *G. insularis* differ considerably from those of other *Gnomulus* species. A superficial resemblance in penis form with *G. coniceps* (stylus tube-like; MARTENS & SCHWENDINGER 1998: figs 90-93) from the Philippines is probably the result of convergence.

Due to the widespread use of sifting techniques for collecting soil mesofauna during the last decades, many more small and untypical species were discovered and described recently, which considerably extended the traditional limits of *Gnomulus* (see MARTENS & SCHWENDINGER 1998). The genus now covers a much wider range of external characters, e.g., body length 2.34-8.94 mm, tarsal formula 2-2-2-2 (in *G. laruticus* and *G. crucifer*) and 2-2-3-3, eye tubercle present or absent. Variation in penis morphology is also pronounced. The most aberrant species, *G. crucifer*, possesses a strongly enlarged stylus (MARTENS & SCHWENDINGER 1998: figs 71-75), which shows superficial resemblance with the hypertrophical styli in the genus *Caenoncopus* Martens & Schwendinger (1998: figs 5, 9-10, 18-19).

## SPECIES GROUPS

With the number of species in *Gnomulus* increasing, an internal grouping becomes necessary. Genital morphology hereby best reflects relationships among oncopodid species and provides the most useful criteria for a grouping. At present we can provisionally divide *Gnomulus* into the following six species groups:

1. The *rostratus*-group comprises *Gnomulus rostratus* and *G. insularis* from Malaysia. Three new species will be described from Thailand and Malaysia in our next paper; many more species probably exist (1 juv. from Narathiwat Province, southern Thailand, 1 juv. from Kuala Tahan, Taman Negara, Pahang and 1 ♀ from Bukit Timah, Singapore examined). Due to its unique penis morphology and unusual eye tubercle, this is the most clearly distinguished group within *Gnomulus*, obviously forming a monophyletic group. It may need to be re-evaluated for generic distinction after additional species (and ♂♂) have become known.

2. The *aborensis*-group is represented by *G. hyatti*, *G. aborensis* and *G. lannaianus* from the northwest of the known distribution of the family. These species possess similar penes, quite strong chelicerae in males, a low interocular area and dorsal scutal areas divided by a distinct median furrow. The *aborensis*-group is not as clearly defined as the *rostratus*-group, but it also appears to be derived from a common ancestor.

3. The *asli*-group comprises *G. laruticus*, *G. asli* and *G. hirsutus* from peninsular Malaysia. These are small to very small species with a rounded eye tubercle and with a similar penis morphology. Despite the unusual tarsal formula (2-2-2-2) of *G. laruticus*, they are probably close relatives. Externally these species resemble those of the *goodnighti*-group from the Philippines, but penis morphology indicates closer affinities with congeners from peninsular Malaysia and Sumatra.

4. The *sumatranus*-group presently contains only the very large (almost 9 mm body length) *G. sumatranus* from Sumatra, which is distinguished by a unique armament on the palpal femur, by keeled dorsal scutal areas and by a pronounced sexual dimorphism. Another species to be placed in this group shall be described in our next paper.

5. The *goodnighti*-group comprises small (about 3 mm long) species from the Philippines, which show a tendency towards enlargement of the stylus and modification of the other parts of the glans penis. These species are: *G. maculatus*, *G. coniceps*, *G. crucifer*, *G. leyteensis* and *G. goodnighti*. *Gnomulus inadatei* from Brunei seemingly and *Gnomulus minor* (generic placement uncertain) presumably belong here too. In terms of genital morphology, this is clearly the most diverse group.

6. The *armillatus*-group is an assemblage of the remaining species, i. e. *G. piliger*, *G. pulvillatus*, *G. armillatus*, *G. drescoi*, *G. thorelli*, *G. laevis*, *G. sundanicus*, *G. annulipes*, *G. baharu*, *G. conigerus* and *G. palawanensis*. These are medium-sized species (5.8-8.6 mm) with a conical eye tubercle, distributed over peninsular Malaysia and the islands of Sumatra, Java, Borneo and Palawan. Additional species shall be described also from Thailand. External morphology in this group is fairly uniform but variation in penis morphology is more pronounced. It possibly does not represent a monophyletic group.

At the present state of knowledge, only the *rostratus*-group appears reasonably distinct in external and genital characters. All other groups are more or less clearly linked by intermediate forms and no major morphological discontinuities can be observed which may warrant generic separation. As further untypical *Gnomulus* species await description, a re-evaluation of this grouping will be taken into account afterwards.

## INTRASPECIFIC VARIATION

Intraspecific variation in Oncopodidae was previously little known because of the rarity of conspecific material available for examination. From the species described recently, we learned that sexual dimorphism in *Gnommlus* is expressed in the shape of several external characters. Males have: more elevated ventral scutal areas [present in all larger species (cf. SCHWENDINGER 1992: 196), but apparently not in the small *G. laruticus*, *G. asli*, *G. maculatus*, *G. coniceps*, *G. crucifer*, *G. leyteensis*, *G. goodnighti*], a denser pubescence on ventral scutal areas [distinct in *G. aborensis*, *G. lannaianus*, *G. insularis*, *G. rostratus*, probably also in *G. piliger*, *G. pulvillatus* (♀ unknown); less distinct in *G. asli*, *G. hirsutus*], a longer carapace and a less elevated interocular area (in *G. aborensis*, *G. lannaianus*, *G. sumatransis*), stronger chelicerae (in *G. sumatransis*, *G. aborensis*, *G. lannaianus*, *G. laevis*, *G. annulipes*, to a lesser extent in *G. armillatus*) and longer processes on ventral palps (in *G. armillatus*).

Apart from this, we find considerable variation in external characters between conspecific animals of the same sex within the same population. Eye tubercles and palp processes often have quite individual shapes, as, e.g., seen in 3 ♀ of *G. armillatus* from Fort de Cock (Figs 116-118). The same also holds true for variation among different populations. Whenever more than just a few conspecific specimens are available for examination, we usually find fairly different eye tubercle shapes [see *G. rostratus* (Figs 54, 58-67), *G. armillatus* (Figs 116-123), *G. laevis* (Figs 148, 156-158) and *G. annulipes* (Figs 166-168)]. This character should therefore be used with caution.

A certain degree of intraspecific variation is also present in genital characters, as seen in some details (especially the median plate) of the penes of *G. insularis* (Figs 22, 25-27), *G. rostratus* (Figs 41, 43-52) and *G. armillatus* (Figs 110-115). For other species see SCHWENDINGER (1992) and MARTENS & SCHWENDINGER (1998).

## ACKNOWLEDGEMENTS

Dr Bernd Hauser (MHNG) ignited this study and continuously fuelled it with specimens, literature and help in tracing localities. Further material was kindly made available by the following colleagues: Dr Ben Brugge (ZMA), Dr Hieronymus Dastych (ZMH), Dr Jason Dunlop (ZMB), Dr Christa Deeleman-Reinhold (Ossendrecht), Dr Giuliano Doria (MSNG), Dr Manfred Grasshoff (SMF), Dr Ivan Löbl (MHNG), Mrs Janet Margerison and Dr Paul Hillyard (both NHML), Dr Pekka Lehtinen (ZMT), Dr Norman I. Platnick (AMNH), Dr Christine Rollard (MHNP), Dr Nicolaj Scharff (ZMC). Dr William A. Shear (Hampden-Sydney College) provided information and specimens. Dr Jürgen Gruber (Naturhistorisches Museum, Wien) critically read the manuscript of this paper. Dr C. Deeleman-Reinhold, Janet Margerison, Liz Price (Kuala Lumpur), Dr Robert Cunningham (Surat Thani) and Dr N. Scharff helped locating places in SE-Asia. Mrs Käthe Rehbinder (Mainz) skillfully produced the whole-animal figures. Dipl.-Biol. Peter Jäger (Mainz) drew our attention



to the formally incorrect type species designation in *Gnomulus* and Dr Philip Tubbs (NHML) further commented on it. Dr Barbara Thaler-Knoflach assisted in raising live opilionids, Prof. Dr Konrad Thaler (Universität Innsbruck) provided literature and research facilities. Mr Konrad Eller, Mr Willi Salvenmoser and Mr Karl Schatz (Universität Innsbruck) helped producing SEM-micrographs. Dr Stephen Elliott (Chiang Mai University) checked the English text. The German Academic Exchange Service (Deutscher Akademischer Austauschdienst, Bonn) supported P. J. Schwendinger with a 1-month research grant to stay in Mainz at the beginning of the oncopodid project. The Feldbausch Foundation at "Fachbereich Biologie" of Mainz University provided travel funds to J. Martens. We are grateful to all friends, colleagues and institutions mentioned.

## REFERENCES

- ANNADALE, N. & ROBINSON, H. C. 1903. Itinerary in Perak, Selangor, and the Siamese Malay States. *Fasciculi Malayenses* (Supplement) 1: 1-43. 1 map.
- BECCARI, N. 1930. Odoardo Beccari in Sumatra e la scoperta dell' "*Amorphophallus Titanum*" (Frammenti di diario Beccari inediti trascritti ed ordinati). *Bollettino della R. Società Geografica Italiana* (serie 6) 7: 569-595.
- BECCARI, O. 1904. Wanderings in the great forests of Borneo. *Archibald Constable & Co. Ltd., London*.
- HELVENSEN, O. VON & MARTENS, J. 1972. Unrichtige Fundort-Angaben in der Arachniden-Sammlung Roewer. *Senckenbergiana biologica* 53 (1/2): 109-123.
- INTERNATIONAL TRUST FOR ZOOLOGICAL NOMENCLATURE, 1985. International Code of Zoological Nomenclature (3<sup>rd</sup> edition). *University of California Press, Berkeley and Los Angeles*.
- LOMAN, J. C. C. 1893. Opilioniden von Sumatra, Java und Flores. In: WEBER, M. (ed.). *Zoologische Ergebnisse einer Reise in Niederländisch Ost-Indien* 3: 1-26. *Leyden*.
- LOMAN, J. C. C. 1902. Neue aussereuropäische Opilioniden. *Zoologische Jahrbücher. Abteilung für Systematik* 16: 163-216.
- LOMAN, J. C. C. 1903. Vergleichend anatomische Untersuchungen an chilenischen und anderen Opilioniden. *Zoologische Jahrbücher* (Supplement 6) 3: 117-200, plates X-XIII.
- LOOSE, S. 1996. Sumatra. Travel Handbuch, Band 15. *Stefan Loose Verlag, Berlin*.
- MARTENS, J. 1977. Opiliones aus dem Nepal-Himalaya. III. Oncopodidae, Phalangodidae, Assamiidae (Arachnida). *Senckenbergiana biologica* 57: 295-340.
- MARTENS, J. & SCHWENDINGER, P. 1998. A taxonomic revision of the family Oncopodidae I. New genera and new species of *Gnomulus* Thorell (Opiliones, Laniatores). *Revue suisse de Zoologie* 105 (3): 499-555.
- POCOCK, R. I. 1897. Descriptions of some new Oriental Opiliones recently received by the British Museum. *Annals and Magazine of Natural History, including Zoology, Botany and Geology* 19: 283-292.
- POCOCK, R. I. 1903. On some new harvest-spiders of the order Opiliones from the southern continents. *Proceedings of the Zoological Society of London* 1902: 392-413.
- RIDLEY, H. N. 1898. The white snake of the Selangore Caves. *Journal of the Straits Branch of the Royal Asiatic Society* 1898: 99-101.
- ROEWER, C. F. 1913. Zoological Results of the Abor Expedition: XIV. Arachnida, II: Opiliones. *Records of the Indian Museum* 8 (3): 203-207.
- ROEWER, C. F. 1915. 106 neue Opilioniden. *Archiv für Naturgeschichte* 81 (3): 1-152.

- ROEWER, C. F. 1923. Die Weberknechte der Erde. *Fischer, Jena*.
- ROEWER, C. F. 1927. Weitere Weberknechte I. *Abhandlungen herausgegeben vom naturwissenschaftlichen Verein zu Bremen* 26 (2): 261-402.
- SCHWENDINGER, P. J. 1992. New Oncopodidae (Opiliones, Laniatores) from Southeast Asia. *Revue suisse de Zoologie* 99 (1): 177-199.
- SCHWENDINGER, P. J. & MARTENS, J. 1999. Case 3116. *Gnomulus* Thorell, 1890 (Arachnida, Opiliones): proposed designation of *G. sumatranus* Thorell, 1891 as the type species. *Bulletin of Zoological Nomenclature* 56 (3): 171-173.
- ŠILHAVÝ, V. 1962. Un opilion nouveau, *Pelitus drescoi* n. sp. (Fam. Oncopodidae). *Bulletin du Muséum national d'histoire naturelle, Paris* (série 2) 34 (6): 464-466.
- SKEAT, W. W. 1954. Reminiscences of the Cambridge University expedition to the north-eastern Malay states, 1899-1900. In: GIBSON-HILL, C. A. (ed.). The Cambridge University expedition to the north-eastern Malay states, and to upper Perak. 1899-1900. *Journal of the Malayan Branch of the Royal Asiatic Society* 26 (4): 9-147.
- SØRENSEN, W. 1932. Descriptiones laniatorum (Arachnidorum Opilionum Subordinis) fecit William Sørensen opus posthumum recognovit et edidit Kai L. Hendriksen. *Mémoires de l'Académie Royale des Sciences et des Lettres de Danemark, Copenhague (Section des Sciences)* (série 9) 3 (4): 199-422.
- SUZUKI, S. 1969. On a collection of opilionids from Southeast Asia. *Journal of Science of the Hiroshima University (series B, division 1, zoology)* 22: 11-77.
- SUZUKI, S. 1977. Report on a collection of opilionids from the Philippines. *Journal of Science of the Hiroshima University (series B, division 1, zoology)* 27: 1-120.
- SUZUKI, S. 1982. Contributions to the taxonomy and zoogeography of the Opiliones of the Philippines, Bismarck and Solomon Islands. With an appendix on some related species from the Moluccas and Sumatra. *Steenstrupia* 8 (8): 181-225.
- SUZUKI, S. 1983. Additional notes on the Malaysian harvestmen (Arachnida: Opiliones). *Acta arachnologica* 32: 1-4.
- THORELL, T. 1890. Aracnidi di Pinang raccolti nel 1889 dai signori L. Loria e L. Fea. *Annali del Museo civico di storia naturale di Genova* (2) 10: 269-383.
- THORELL, T. 1891. Opilioni nuovi o poco conosciuti dell'Arcipelago Malese. *Annali del Museo civico di storia naturale di Genova* (2) 10: 669-770, plates VIII - IX.
- TSURUSAKI, N. 1990. *Gnomulus minor*, a new species of oncopodid harvestmen from Luzon, the Philippines. *Acta arachnologica* 39: 59-62.

## Weitere Angaben zur Regenwurmfauna Frankreichs mit Beschreibung fünf neuer Arten (Oligochaeta: Lumbricidae)

András ZICSI & Csaba CSUZDI

Zootaxonomische Forschungsgruppe der Ungarischen Akademie der Wissenschaften  
am Lehrstuhl für Tiersystematik und Ökologie der Eötvös-Loránd Universität,  
Puskin utca 3, H-1088 Budapest, Ungarn.

**Further contribution to the earthworm fauna (Oligochaeta: Lumbricidae) of France, with description of five new species and one subspecies.** - The study of a larger collection of earthworms from different regions of France enables comments on genera described from this country and on some other recently described genera: *Orodriilus* Bouché, 1972, *Proselodrilus* Bouché, 1972, *Kritodrilus* Bouché, 1972, *Satchellius* Gates, 1978, *Murchieona* Gates, 1978, *Allolobophoridella* Mnsic, 1990. Five species and one subspecies are described as new to science: *Lumbricus klarae* sp. n., *Kritodrilus tetryae* sp. n., *Kritodrilus micrurus* sp. n., *Aporrectodea hayuoziiformis* sp. n., *Proselodrilus albus* sp. n., and *Lumbricus friendi bouchei* ssp. n.

**Key-words:** Earthworms - Lumbricidae - taxonomy - France.

### EINLEITUNG

Seit der 1972 von BOUCHÉ veröffentlichten Monographie über die Regenwürmer Frankreichs sind ausser den vom Erstautor (1977 a, b) erschienen kleinen Beiträgen keine weiteren Angaben über französische Vorkommen von Lumbricidae veröffentlicht worden. Offensichtlich war die Zahl der beschriebenen neuen Taxa (75) und die der wiedergefundenen bekannten Regenwürmer so überwältigend gross, dass sich ein weiteres Suchen nach dieser Tiergruppe erübrigte. Zweifelsohne hat BOUCHÉ (1972) durch Aufstellung von Gattungen, Beschreibung neuer Arten bzw. Unterarten eine Vielfalt neuer Kenntnisse für die Wissenschaft erbracht, die eben wegen ihrer Vielfältigkeit kaum kritisch gewertet werden konnten. Deswegen wurden seine taxonomischen Ergebnisse vorwiegend auch kritiklos übernommen, wenn nicht, dann ohne die Arten Frankreichs zu kennen, wie dies im Falle von OMODEO (1988), OMODEO & ROTA (1989) und MRSIC (1991) geschah. Da die Begrenzungen der Gattungen nur auf Grund der in Frankreich vorkommenden Arten erfolgten, die bisher beschriebenen übrigen Arten nicht berücksichtigt und bei den neu aufgestellten Gattungen keine Differenzialdiagnosen gegeben wurden, kann ohne Kenntnis dieser Taxa zu den im System der Lumbricidae vollzogenen Veränderungen auch nicht mit

Sicherheit Stellung genommen werden. Dies ist der Grund dafür, dass wir uns bisher keiner dieser Veränderungen angeschlossen haben. Obwohl seit der Revision des Erstautors (ZICSI 1982) die Zahl der Taxa auf mehr als das Doppelte gestiegen ist, wird unsererseits die Aufstellung neuer Gattungen ebenfalls befürwortet. Aber dies darf unseres Erachtens nach nur in Kenntnis sämtlicher betroffener Arten durchgeführt werden und nicht nur allein aufgrund der Fauna eines Landes. Da dies die ganze Paläarktis betrifft, müssten noch zahlreiche Arten aus den verschiedensten Teilen dieser Region überprüft und Beschreibungen revidiert werden, bis ein einheitlicher Überblick möglich ist und eine kritische Beurteilung der Familie Lumbri-*cidae* erfolgen kann.

Die vorliegende Arbeit hat zum Ziel, die von verschiedenen Fundorten stammenden, in der Sammlung des Naturhistorischen Museums Genf aufbewahrten Arten aus Frankreich bekanntzugeben. Zusätzliche Aufsammlungen wurden durch den Erstautor (1982) und beide Autoren (1997) in den Pyrenäen durchgeführt.

Zusätzlich zu den Beschreibung neuer bzw. zur Meldung bekannter Arten wird zu den von verschiedenen Autoren aufgestellten Gattungen Stellung genommen.

Das bearbeitete Material wird in der Sammlung des Naturhistorischen Museums Genf (G), Belegexemplare auch am Tiersystematischen und Ökologischen Lehrstuhl der Universität Budapest (Z) aufbewahrt.

## BESPRECHUNG DER ARTEN

### FUNDORTLISTE

Sämtliche Fundorte ohne Angabe des Sammlers beziehen sich auf die Sammeltätigkeit von P. Haymoz (Naturhistorisches Museum, Genf), die Abkürzung DFK steht für Dózsa-Farkas Klára.

#### *Dépt. de la Haute-Savoie*

1. Carrières de Veyrier au Pas-de-l'Echelle, 1/1. 470 m, 26.1.1974. 1/2. 9.2.1974. 1/3. 17.2.1974. 1/4. 4.1.1975. 1/5. 430 m, 17.9.1978. 1/6. 8.10.1978. 1/7. 10.6.1979. 1/8. 600 m, 16.9.1979. 1/9. 28.10.1979. 1/10. 9.12.1979
2. Chambéry le Vieux, 300 m, 26.8.1978
3. Fontaine, 28.7.1973
4. Grotte du Diable, 4/1. 19.8.1973. 4/2. 1.9.1973
5. La Laysse, 30.9.1979
6. La Motte-Servolex, 2.7.1978
7. Lucinges, 7/1. 730 m, 3.9.1979. 7/2. 800 m, 13.10.1979. 7/3. 750 m, 20.10.1979. 7/4. 730 m, 27.10.1979. 7/5. 700 m, 27.3.1982. 7/6. 750 m, 3.10.1982
8. Monnetier, 8/1. 9.2.1975. 8/2. 750 m, 17.4.1979
9. Petit-Salève, 9/1. 700 m, 26.1.1973. 9/2. 750- 800 m, 14.4.1974. 9/3. 700 m, 26.1.1975. 9/4. 750 m, 23.2.1975. 9/5. 750 m, 18.9.1977. 9/6. 750-800 m, 25.9.1977. 9/7. 1250 m, 15.7.1981
10. Vouglans, 30.9.1979

#### *Dépt. de l'Ain*

11. Bellegarde, 11/1. 8.7.1973. 11/2. 500 m, 11.4.1982. 11/3. 28.5.1983
43. Nardérant - Reculet, 1500 m, Jura, 30.5.1982

12. Beriaz, 467 m, 28.7.1973
13. Ceignes, 600 m, 10.8.1973
14. Champfromier, 700 m, 4.10.1980
15. Grottes du Séznet, 15/1. 700 m, 8.9.1973. 15/2. 800 m, 16.9.1973. 15/3. 700 m, 11.11.1973
16. Mollou-Ravin, 16/1. 250 m, 27.9.1975. 16/2. 1.10.1972
17. Pont-d'Ain, 25.9.1974
18. Pyrimont, 28.7.1973
19. Soblay, 307 m, 10.8.1973
20. Thoiry, 16.5.1982
21. Vallon d'Arlod 21/1. 5.4.1980. 21/2. 13.4.1980. 21/3. 7.9.1980. 21/4. 11.7.1981. 21/5. 26.7.1981

*Dépt. Saône-et-Loire*

22. Rocher du Solutré, 25.8.1973

*Dépt. de l'Isère*

23. Verpillière, 10.8.1974
44. St. Joseph de Rivière, 19.9.1982
45. St. Lattier les Fauries, 19.9.1982

*Dépt. de l'Essone*

24. Auver-Saint-Georges, 26.7.1974

*Dépt. du Puy-de-Dôme*

25. Colombier des Roys, 11.4.1977
26. Orciens, 850 m, 25.6.1982
27. Pont de Château, 26.6.1982

*Dépt. de la Marne*

28. Chavot 28/1. 1.7.1981. 28/2. 3.7.1981
29. Cuis, 1.7.1981
30. Epermev, 6.8.1979
31. Mt. de Reims, 30.6.1981
32. Rilbyla Mt., 150 m, 7.8.1981

*Dépt. de l'Indre*

33. Buzançais, 19.5.1980
34. Grand Chaventon, 23.5.1980
35. Pointe de la Touche, 21.5.1980

*Dépt. de la Gironde*

36. St. Jean-d'Etampes, 26.7.1980
37. Saucats, 26.7.1980

*Dépt. de la Drôme*

38. Eglise d'Hauterives, 1.6.1985
39. Tersanne, 39/1. 400 m, 39/2. 3.10.1981. 26.5.1985, leg. P. Haymoz und A. Rivand
40. Valras, 20.6.1984
41. Vinsobres, 21.6.1984

*Dépt. de la Charente-Maritime*

42. Saujon, 26.6.1983

*Dépt. des Alpes de Haute Provence*

46. Montagne de Lure, 1000 m, 3.4.1978, leg. Löbl und Bouchet

*Dépt. de l'Hérault*

47. Béziers, 9.9.1982 - 10.9.1982, leg. Zicsi

*Dépt. de l'Ariège*

48. Castillon, 13.9.1982, leg. Zicsi  
 49. Lac de Bemale, 13.9.1982, leg. Zicsi  
 74. Moulis - Remilassé, 230 m, (42°56'51"N: 1°05'38"O), 27.6.1997, leg. Zicsi - Csuzdi - DFK  
 75. Audressein, 500 m, (42°55'34"N: 1°01'10"O), 27.6.1997, leg. Zicsi - Csuzdi - DFK  
 76. St. Lary, 700 m, (42°45'10"N: 0°53'07"O), 27.6.1997, leg. Zicsi - Csuzdi - DFK

*Dépt. des Pyrénées-Atlantiques*

50. Camou-Cihigue, 14.9.1982, leg. Zicsi  
 51. Louvie-Juzon, 15.9.1982, leg. Zicsi  
 52. Orolon, 14.9.1982, leg. Zicsi  
 53. Ossas-Suhare, 14.9.1982, leg. Zicsi  
 54. St. Etienne, 6.9.1982, leg. Zicsi  
 57. Ossas, 200 m, (43°08'16"N: 0°53'32"O), 22.6.1997, leg. Zicsi - Csuzdi - DFK  
 58. St. Engrace, 500 m, (43°08'16"N: 0°53'32"O), 22.6.1997, leg. Zicsi - Csuzdi - DFK  
 59. Haux, 300 m, (43°04'35"N: 0°53'57"O), 22.6.1997, leg. Zicsi - Csuzdi - DFK  
 60. Esterencubi, 250 m, (43°06'44"N: 1°12'28"W), 23.6.1997, leg. Zicsi - Csuzdi - DFK  
 61. Esterencubi - Iraty, 600 m, (43°04'11"N: 1°10'57"W), 23.6.1997, leg. Zicsi - Csuzdi - DFK  
 62. Beherobie, 650 m, (43°03'58"N: 1°12'57"W), 23.6.1997, leg. Zicsi - Csuzdi - DFK  
 63. Beherobie. Orion Bach, 600 m, (43°04'09"N: 1°12'43"W), 23.6.1997, leg. Zicsi - Csuzdi - DFK  
 64. St. Michel, 300 m, (43°07'50"N: 1°13'37"W), 23.6.1997, leg. Zicsi - Csuzdi - DFK  
 65. Col d' Osquich, 350 m, (43°13'33"N: 0°22'52"W), 24.6.1997, leg. Zicsi - Csuzdi - DFK  
 66. Osses, 350 m, (43°14'10"N: 1°18'27"W), 24.6.1997, leg. Zicsi - Csuzdi - DFK  
 67. Col d' Ipequy, 550 m, (43°10'54"N: 1°22'52"W), 24.6.1997, leg. Zicsi - Csuzdi - DFK  
 68. Arette Bach, 260-300 m, (43°05'50"N: 0°43'16"W), 25.6.1997, leg. Zicsi - Csuzdi - DFK  
 69. Issor, 500 m, (43°05'28"N: 0°42'09"W), 25.6.1997, leg. Zicsi - Csuzdi - DFK  
 70. Asasp, leg. Zicsi - Csuzdi - DFK 70/1. Le Lourdios Bach, 450 m, (43°06'26"N: 0°8'23"W), 25.6.1997. 70/2. 380 m, (43°07'08"N: 0°32'49"W)

*Dépt. des Hautes-Pyrénées*

55. Castelnaud, 12.9.1982, leg. Zicsi  
 56. Loucrup, leg. Zicsi, 56/1. 15.9.1982. 56/2. 500 m, (43°07'06"N: 0°04'40"W), 26.6.1997, leg. Zicsi - Csuzdi - DFK  
 71. Lanne, 400 m, (43°09'50"N: 0°0'11"W), 26.6.1997, leg. Zicsi - Csuzdi - DFK  
 72. Visker, Eches Bach, 400 m, (43°08'43"N: 0°02'43"W), 26.6.1997, leg. Zicsi - Csuzdi - DFK  
 73. Arcizac - Adour, 500 m, (43°08'51"N: 0°04'56"W), 26.6.1997, leg. Zicsi - Csuzdi - DFK

*Dépt. de la Haute-Garonne*

77. Aspet, 530 m, (42°57'57"N: 0°47'33"W), 27.6.1997, leg. Zicsi - Csuzdi - DFK

*Dépt. Territoire-de-Belfort*

78. Cesarhof, Sundgaurand, 5.6.1981, leg. Bono

## LUMBRICIDAE Rafinesque-Schmaltz, 1815

Da nicht nur die Zahl der Arten seit der letzten Revision (Zicsi 1982) gestiegen ist, sondern auch die der Gattungen bzw. Untergattungen von 17 auf 44, fassen wir diese vorausgehend, nach Autoren geordnet, zusammen.

Bouché: *Diporodrilus*, 1970, *Ethnodrilus*, 1972, *Orodrilus*, 1972, *Prosello-drilus*, 1972, *Kritodrilus*, 1972, *Nicodrilus*, 1972, *Rhodoniscus*, 1972, *Scherotheca*, 1972, *Opothedrilus*, 1972, *Spermophorodrilus*, 1975.

Easton: *Perelia*, 1983 (nom. nov. pro *Svetlovia* Perel, 1976).

Eisen: *Dendrobaena*, 1873, *Allolobophora*, 1874.

Gates: *Eisenoides*, 1969, *Satchellius*, 1978, *Murchieona*, 1978.

Hoffmeister: *Helodrilus*, 1845.

Linnaeus: *Lumbricus*, 1758.

Malm: *Eisenia*, 1877.

Michaelsen: *Eiseniella*, 1900.

Moore: *Bimastos*, 1893.

Mrsic: *Alpodinariella*, 1987, *Dinariella*, 1987, *Creinella*, 1987, *Meroandriella*, 1987, *Allolobophoridella*, 1990.

Mrsic & Sapkarev: *Zicsiona*, 1987, *Italobalkaniona*, 1988, *Serbiona*, 1988, *Panioniona*, 1988, *Karpatodinariona*, 1988.

Omodeo: *Cernosvitovia*, 1956, *Dendrodrius*, 1956, *Eiseniona*, 1956, *Microeophila*, 1956, *Octodrilus*, 1956, *Healyella*, 1989.

Örleyi: *Aporrectodea*, 1885, *Octolasion*, 1885.

Rosa: *Eophila*, 1893.

Zicsi: *Fitzingeria*, 1978, *Proctodrilus*, 1985, *Octodriloides*, 1986.

Da für einen Teil der angeführten Gattungen Merkmale nicht bekannt sind, die neuerdings zur Begrenzung der supraspezifischen Taxa ebenfalls herangezogen werden, kann ein endgültiger Gattungsschlüssel nicht vorgelegt werden. Wir versuchen die Arten der für uns bislang unbekannteren Gattungen eindeutig zu definieren und, soweit dies erforderlich ist, die Arten aus anderen Teilen der Paläarktis einzuordnen.

### **Lumbricus L., 1758**

Die meisten Arten der Gattung *Lumbricus* sind aus den westlichen Teilen Europas beschrieben worden, von wo eine Verschleppung nach Osten erfolgte. Wie aus den Verbreitungskarten der Arten dieser Gattung aus Frankreich (BOUCHÉ 1972: p. 354, 375; Abb. 50 u. 54) hervorgeht, kommen einige Arten, wie *L. friendi* nur in den südlichen Teilen Frankreichs, vorwiegend im Gebiet der Pyrenäen vor, wo die weitverschleppte Art *L. terrestris* nicht auftritt. Diese Verbreitung in Frankreich wird durch unsere Fundorte bestätigt. Das Fehlen von *L. terrestris* in südlicheren Teilen Europas (DIAZ COSIN *et al.* 1992) kann auch durch unsere Erfahrungen aus Serbien (Grenze von Kosovo) bestätigt werden, wo sie nur bis Pecs anzutreffen war, südlich davon und in Griechenland konnte sie nicht gesammelt werden (ZICSI & MICHALIS 1981).

### **Lumbricus terrestris L., 1758**

Fundorte: Nr. 1/2. G/1106 2 Ex., Z/9338 1 Ex., Nr. 1/4. G/1449 1 Ex., Nr. 1/6. G/1462 1 Ex., Nr. 1/7. G/1444 2 Ex., Nr. 1/9. G/1644 3 Ex., Nr. 3. G/969 1 Ex., Nr. 7/1. G/1589 4 Ex..

Z/9507 3 Ex., Nr. 7/2. G/1608 4 Ex., Nr. 7/3. G/1770 4 Ex., Nr. 7/4. G/1607 4 Ex., Nr. 8/1. G/994 1 Ex., Nr. 8/2. G/1456 2 Ex., Nr. 9/4. G/1116 2 Ex., Nr. 9/5. G/1422 9 Ex., Nr. 9/6. G/1428 2 Ex., Nr. 11/1. G/970 1 Ex., Nr. 15/1. G/977 4 Ex., Nr. 16/1. G/1096 1 Ex., Nr. 17. G/1095 1 Ex., Nr. 19. G/981 7 Ex., Z/7824 4 Ex., Nr. 21/1. G/1658 1 Ex., Nr. 21/2. G/1669 1 Ex., Nr. 21/3. G/1654 1 Ex., Nr. 21/4. G/1788 1 Ex., Nr. 23. G/985 2 Ex., Nr. 25. G/1418 1 Ex., Z/9345 1 Ex., Nr. 26. G/1915 1 Ex., Nr. 28/2. G/1787 1 Ex., Nr. 29. G/1807 1 Ex., Nr. 38. G/2357 1 Ex., Z/10774 2 Ex., Nr. 39/2. G/2350 1 Ex., Nr. 41. G/2061 1 Ex., Nr. 42. G/2037 4 Ex., Z/9814 5 Ex., Nr. 44. G/2053 1 Ex., Z/9824 2 Ex., Nr. 45. G/2059 1 Ex.

### ***Lumbricus friendi friendi* Cognetti, 1904**

Fundorte: Nr. 16/1. G/1097 1 Ex., Nr. 20. G/1879 3 Ex., Nr. 42. G/2031 1 Ex., Z/9808-09 27 Ex., Nr. 43. G/1845 9 Ex., Nr. 51. G/2065 1 Ex., Z/9841 1 Ex., Nr. 55. G/1943 1 Ex., Nr. 56/1. Z/12550 3 Ex., Nr. 57. Z/12490 7 Ex., Nr. Z/59. G/2539 3 Ex., Z/12572 5 Ex., Nr. 69. Z/12538 3+2 Ex., Nr. 70/1. G/2543 2 Ex., Z/12546 4+4 Ex., Nr. 71. Z/12558 1 Ex., Nr. 72. G/2541 2 Ex., Z/12525 2 Ex., Nr. 73. Z/12560 2+1 Ex., Nr. 74. Z/12564 3+2 Ex., Nr. 75. Z/12568 3+1 Ex., Nr. 76. G/2540 1 Ex., Z/12573 3 Ex.

Dies ist die häufigste in den Pyrenäen vorkommende *Lumbricus* Art.

### ***Lumbricus friendi bouchei* sp. n.**

*Lumbricus friendi* var. *lineatus* Bouché, 1972: 357

Fundorte: Holotypus Z/12558 Dépt. des Hautes-Pyrénées Lanne, 400 m leg. Zicsi-Csuzdi-DFK. Paratypen: Nr. 48 G/1945 2 Ex., Z/9783 2 Ex., Z/9785 2 Ex., Nr. 57. G/2542 4 Ex., Z/12487 16 Ex., Nr. 69. Z/12538 3+2 Ex., Nr. 71. Z/12558 1 Ex.

Diagnose: L. 70-90 mm, B. 5-6 mm, Segmentzahl 102-113. Rotbraun. Kopf tanylobisch. Gürtel vom 33.-37., Pubertätsstreifen linienförmig vom 34.-36. Segment. Innere Organisation wie bei *L. friendi*.

Bei der Bestimmung unseres Materials sind wir dem Unterschied in der Ausbildung der Pubertätsorgane, den Bouché veranlasste, die Varietät *lineatus* zu beschreiben, ebenfalls begegnet. Dieser Unterschied ist nicht mehr oder weniger bedeutend als der, der bei *A. caliginosa caliginosa* und *A. caliginosa trapezoides* zur Aufstellung einer Unterart führte. Da bei *L. friendi* und *L. friendi* v. *lineatus* auf dem 34.-36. Segment die gleichen Unterschiede bestehen stellen wir für v. *lineatus* eine neue Unterart auf.

Beschreibung vergl. BOUCHÉ (*Lumbricus friendi* var. *lineatus* 1972: p. 357).

### ***Lumbricus klarae* sp. n.**

Fundort: Holotypus. Z/12947. Esterencubi, 250 m, (43°06'44"N: 1°12'28"W), 23.6. 1997., leg. Zicsi+Csuzdi+Dózsá-Farkas. Paratypen. Z/12504 2+3 juv. Ex., G/2544 2 Ex., Fundort wie beim Holotypus.

Diagnose: L. 39-71 mm, B. 3-4 mm, Segmentzahl 61-122. Rotbraun. Kopf tanylobisch. Borsten eng gepaart. Gürtel vom 32.-35., Pubertätsstreifen vom 33.-35. Segment. Verdickte Dissepimente fehlen. Herzen im 7.-11., Kalkdrüsen im 10. Segment. Unpaarige Testikelblasen im 10. und 11. Segment. 3 Paar Samensäcke im 9., 11., 12. Segment. Typhlosolis einfach. Nephridialblasen J-förmig. Muskulatur gefiedert. 2 Paar Samentaschen im 10. und 11. Segment.



Länge des Holotypus 71 mm, Breite 4 mm, Segmentzahl 112. Paratypen. Länge 39-68 mm, 3-4 mm, Segmentzahl 61-122.

Farbe rotbraun. Kopf tanylobisch. Borsten am ganzen Körper eng gepaart. Borstendistanz hinter dem Gürtel aa:ab:bc:cd:dd wie 5:1.6:4,3:1:12. Rückenporen vor dem Gürtel undeutlich, wenn vorhanden so auf Intersegmentalfurche 6/7 oder 7/8 beginnend, hinter dem Gürtel deutlich zu erkennen. Nephridialporen oberhalb der Borstenlinie d. Segmente 8-11, 14-16, 26-31 auf der Ventralseite in der Borstenlinie ab etwas drüsig. Borsten ab des 37. Segment von Drüsenpapillen umgeben. Samentaschenporen auf Intersegmentalfurche 9/10 und 10/11 in der Borstenlinie c. Gürtel sattelförmig vom 32.-36. Segment, Pubertätsstreifen vom 33.-35. Segment.

Innere Organisation. Dissepimente 6/7-13/14 nicht verdickt. Schlunddrüsen bis ins 6. Segment reichend. Herzen im 7.-10. Segment gross, im 11. klein. Klalkdrüsen im 10. Segment, sind absteigende, nach vorne gerichtete Ausbuchtungen. Hoden und Samentrichter im 10. und 11. Segment, in unpaarige Testikelblasen eingeschlossen. Samensäcke im 9., 11. und 12. Segment, die des 12. gross, bis ins 19. Segment reichend. Ovarien im 13. Segment, Ovarientrichter auf Intersegmentalfurche 13/14. Kropf im 15.-16. Segment, Muskelmagen im 17.-18. Segment, Thyphlosolis im 19. Segment beginnend. Nephridialblase J-förmig. Muskulatur vom gefiederten Typus.

Die neue Art steht *L. friendi*, *L. centralis* und *L. terrestris* am nächsten, unterscheidet sich von allen dreien in der Lage des Gürtels und der Pubertätsstreifen.

Die neue Art wird zu Ehren von Frau Prof. Dr. Klára Dózsa-Farkas benannt, die uns bei den Aufsammlungen in den Pyrenäen sehr behilflich war.

Bei der Beschreibung von *L. improvisus* (Zicsi, 1963) wurde bereits darauf hingewiesen, dass die Vertreter der Gattung *Lumbricus* in der Gesamtheit ihrer taxonomischen Merkmale sich äusserst nahe stehen. Für die Aufstellung einer neuen Art genügt die Verschiebung der Gürtel- und Pubertätsorgane um ein Segment. Die vorliegenden Exemplare zeigen eine solche Verschiebung, so dass wir uns gezwungen sehen, eine neue Art zu beschreiben.

Das Vorkommen von *L. improvisus* in Frankreich (BOUCHÉ 1972: p. 373) erscheint uns als sehr fraglich, da von jedem Fundort nur Einzelstücke vorlagen. Eine Anomalie kann somit nicht ausgeschlossen werden.

### **Lumbricus castaneus** (Savigny, 1826)

Fundorte: Nr. 1/1. G/1108 3 Ex., Z/9329 3 Ex., Nr. 1/2. G/1101 16 Ex., Z/9336 1 Ex., Nr. 1/5. G/1453 1 Ex., Nr. 1/10. G/1678 2 Ex., Nr. 3/7. G/1768 2 Ex., Nr. 4/2. G/962 4 Ex., Nr. 4/2. G/983 2 Ex., Nr. 6. G/1439 4 Ex., Nr. 7/1. G/1590 2 Ex., Z/9505 2 Ex., Nr. 7/2. G/1609 2 Ex., Nr. 7/4. G/1606 5 Ex., Nr. 8/1. G/995 3 Ex., Nr. 8/2. G/1457 12 Ex., Z/99322 5 Ex., Nr. 9/7. G/1803 1 Ex., Nr. 12. G/972 1 Ex., Nr. 13. G/965 3 Ex., Nr. 15/1. G/975 3 Ex., Nr. 15/2. G/971 2 Ex., Z/7822 2 ex., Nr. 15/3. G/974 1 Ex., Z/7823 3 Ex., Nr. 16/2. G/1437 1 Ex., Nr. 18. G/968 1 Ex., Nr. 20. G/1878 16 Ex., Nr. 21/1. G/1659 2 Ex., Z/9556 1 Ex., Nr. 21/2. G/1670 5 Ex., Nr. 21/4. G/1789 1 Ex., Nr. 25. G/1417 17 Ex., Z/9346 9 Ex., Nr. 26. G/1916 3 Ex., Nr. 30. G/1470 1 Ex., Nr. 31. G/1799 4 Ex., Nr. 33. G/1598. 3 Ex., G/1627 3 Ex., G/1633 7 Ex., Z/9528 5 Ex., Z/9514 5 Ex., Nr. 34. G/1623 12 ex., Z/9552 15 ex., Nr. 35. G/1579 15 Ex., Z/9539 19 Ex., N Nr. 37. G/1693 1 Ex., Nr. 38. G/2352 4 Ex., Nr. 39/2. G/2346 2 Ex., Z/10768 6 Ex., Nr. 41. G/2162 8 Ex., Z/10652 9 Ex., Z/12122 30 Ex., Nr. 43. G/1847 4 Ex., Z/12123 27 Ex., Nr. 44. G/2052 3 Ex., Z/9821 7 Ex., Nr. 56/1. Z/12551 5 Ex.

**Lumbricus festivus** (Savigny, 1826)

Fundorte: Nr. 33. G/1597 1 Ex., G/1625 1 Ex., G/1634 5 Ex., G/1677 1 Ex., Z/9526 6 Ex., Z/9545 1 Ex., Nr. 34. G/1617 8 Ex., Z/9554 7 Ex., Nr. 35. G/1582 8 Ex., Z/9542 6 Ex.

**Lumbricus polyphemus** (Fitzinger, 1833)

Fundort: Nr. 78. Z/10725 1 Ex.

**Lumbricus rubellus** Hoffmeister, 1843

Fundorte: Nr. 1/8. G/1522 4 Ex., Nr. 3/7. G/1769 3 Ex., Nr. 4=1. G/963 6 Ex., Nr. 7/1. G/1591 3 Ex., Z/9506 1 Ex., Nr. 7/2. G/1610 1 Ex., Nr. 7/4. G/1605 2 Ex., Z/9515 2 Ex., Nr. 13. G/966 2 Ex., Nr. 22. G/967 5 Ex., Nr. 33. G/1626 4 Ex., G/1632 6 Ex., Z/9529 5 Ex., Nr. 34. G/1621 5 Ex., Nr. 35. G/1580 6 Ex., Z/9540 9 Ex., Nr. 38. G/2353 3 Ex., Nr. 39/2. G/2347 6 Ex., Z/10769 1 Ex., Nr. 43. G/1846 1 Ex.

**Murchieona** Gates, 1978

*Allolobophora* (part.), ROSA 1906: 38, MULDAL 1952: 463, MURCHIE 1959: 329, ZICSI 1968: 404, 1973: 101, 1981: 176, 1982: 433, BOUCHÉ 1972: 452, GATES 1975b: 7, ZICSI & MICHALIS 1981: 251, TRIGO *et al.* 1990: 534, DIAZ COSIN *et al.* 1992: 1352.

*Bimastos* (part.), PICKFORD 1926: 97, OMODEO 1956: 179, GERARD 1964: 34, MRSIC & SAPPKAREV 1988: 31.

*Murchieona* Gates, 1978: 114, EASTON 1983: 483, SIMS & GERARD 1985: 109, MRSIC 1991: 535.

Durch die ungewöhnliche Ausbildung der Kalkdrüsen im 10. Segment (abstehende, nach vorne gerichtete U-förmige Gebilde) und die würstchenförmigen Nephridialblasen sowie durch die Muskulatur vom gefiederten Typ, ist die Gattung in der Familie Lumbricidae gut charakterisiert. Nach Überprüfung von Exemplaren aus Griechenland (ZICSI 1973, ZICSI & MICHALIS 1981), Kroatien (ZICSI 1986), Italien, (ZICSI 1981) wird die neue Gattung auch unserseits anerkannt.

Typusart: *Allolobophora muldali* Omodeo, 1956.

Weitere Art: *M. minuscula* (Rosa, 1906).

**Murchieona muldali** (Omodeo, 1956)

Fundorte: Nr. 57. Z/12489 1 Ex., Nr. 62. Z/12508 1 Ex., Nr. 69. 1 Ex., G/2545 1 Ex., Nr. 70. Z/12544 1 Ex.

Nach Überprüfung von Exemplaren aus verschiedenen südeuropäischen Ländern (vergl. weiter oben) konnten Populationen mit verschiedener Gürtellage unterschieden werden. Bei den Tieren aus Griechenland, Kroatien und Italien liegt der Gürtel am 26., 1/2 26.-32. Segment (*M. minuscula*), bei denen aus Frankreich, Portugal und den offensichtlich Verschleppungsformen in England und den Vereinigten Staaten von Amerika vom 27., 1/2 27.-33. Segment (*M. muldali*). In Anbetracht dieser konstanten Unterschiede wird die Synonymisierung von *muldali* widerrufen (ZICSI 1981), beide Arten werden hiermit anerkannt.

**Helodrilus** Hoffmeister, 1845

*Helodrilus* Hoffmeister, 1845: 88, MICHAELSEN 1900: 495, OMODEO 1953: 75, 1956: 171, PEREL 1976: 833, ZICSI 1985: 277, MRSIC 1991: 101.

Typusart: *H. oculatus* Hoffmeister, 1845.

Die von POP (1941) synonymisierte Gattung *Helodrilus* wurde von *Omodeo* (1953) wieder ins Leben gerufen, ohne sie aber eindeutig zu begrenzen. Sie ist jedoch durch das Fehlen von Nephridialblasen charakterisiert (PEREL 1976). Derzeit sind 19 Arten bekannt (PEREL 1976, 1979, ZICSI 1985, MRSIC 1991).

Bei der Bestimmung des Materials aus den Pyrenäen sind wir auf drei Arten bzw. Unterarten dieser Gattung gestossen.

### ***Helodrilus oculatus* Hofmeister, 1845**

Fundorte: Nr. 37. G/1694 1 Ex., Z/9603 1 Ex., Nr. 70. Z/12545 1 Ex.

Von dieser Art, die zusammen mit *H. putricolus* gesammelt wurde, sind nur wenige Exemplare erbeutet worden. Da von *H. oculatus* oft nur juvenile oder prae-adulte Tiere gefangen werden (die Zeit der vollen Geschlechtsreife hält nur kurz an), ist das Variieren der Gürtel und Pubertätsorgane schwer zu beurteilen. Bei den von uns bestimmten Exemplaren liegt der Gürtel vom Fundort Nr. 37 auf dem 21.-32., die Pubertätsstreifen auf dem 1/4 28. -1/4 31. Segment, bei denen vom Fundort Nr. 70 erstreckt sich der Gürtel vom 22.-32., die Pubertätsstreifen vom 1/2 28.-1/2 31. Segment.

### ***Helodrilus putricola putricola* (Bouché, 1972)**

*Allolobophora putricola putricola* Bouché, 1972 : 442

Fundorte: Nr. 37. G/1695 3 Ex., Z/9604 1 Ex., Nr. 70. Z/12542 4 juv. Ex., Nr. 72. Z/12523. 12524. 18+3 praead.+2 juv. Ex., G/2546 3+3 juv. Ex.

Vom Fundort Nr. 72 liegen uns zahlreiche Exemplare vor, die alle am Bachrand unter Steinen gesammelt wurden. Obwohl unsere Tiere einwandfrei als *H. putricola* identifiziert werden konnten, muss das starke Variieren der Pubertätsstreifen innerhalb einer Population hervorgehoben werden ( Lage des Gürtels vom 23., 1/2 23.-29., 30., die der Pubertätsstreifen vom 23., 24., 25.-28., 29., 1/2 29., 30. Segment). Da die Lage der Pubertätsstreifen, mit Ausnahme der Gattung *Helodrilus*, bei den übrigen Gattungen der Familie Lumbricidae im allgemeinen ein konstantes Artmerkmal ist und nicht mit der Geschlechtsreife der Tiere zusammenhängt, so wie dies beim Gürtel der Fall ist, muss dies bei dieser Art unbedingt erwähnt werden, damit bei Einfängen nicht weitere neue Taxa aufgestellt werden. Bei Schwanzregeneraten am Körperende ist der After rückenständig gelegen.

Von *H. putricola tebra* (Bouché, 1972), die sich durch den Besitz von 3 Paar Samentaschen von der Stammform unterscheidet, wurden keine Exemplare gefangen.

### ***Helodrilus putricola orionensis* (Zicsi, 1977) stat. n.**

*Allolobophora orionensis* Zicsi, 1977 : 682

Fundorte: Nr. 57 Z/12482 14 Ex., G/2547 3+1 juv. Ex., Nr. 61. Z/12505 3 Ex.

In der Originalbeschreibung wurde die Form der Nephridialblasen nicht erwähnt. Eine Nachbestimmung des Holotypus und des reichen neuen Materials erbrachte den Nachweis eines Fehlens von Nephridialblasen, sodass diese Art ebenfalls zur Gattung *Helodrilus* gestellt werden muss. Sie ist nahe verwandt mit *H. putricola*,

von der sie sich durch die 5 Paar Samentaschen unterscheidet. Die Lage des Gürtels und der Pubertätsstreifen, die jetzt an mehreren Exemplaren bestimmt werden konnte, zeigt ein grösseres Variieren (Gürtel vom 23., 1/2 23., 1/2 24.- 29., 30., 31., Pubertätsstreifen vom 23., 1/2 24.- 29., 1/2 30., 30. Segment), sodass wir *orionensis* als Unterart von *putricola* betrachten. Ein rückenständiger After konnte bei einigen Exemplaren ebenfalls beobachtet werden.

### **Kritodrilus Bouché, 1972**

*Kritodrilus* Bouché, 1972: 250, PEREL 1976: 642, EASTON 1983: 482, OMODEO & ROTA 1989: 185.

Typusart: *Octolasion calarensis* Tetry, 1944.

Weitere Arten: *K. osellai* (Zicsi, 1970), *K. ruffoi* (Zicsi, 1970), *K. pseudorosea* (Moreno, 1983).

Von PEREL (1976) wurde die Gattung durch die Form der Nephridialblasen (doppellappig=bilobous) eindeutig definiert. Sie reihte auch *Dendrobaena auriculata* (Rosa, 1897) zu *Kritodrilus*. Später wurden dieser Gattung von OMODEO & ROTA (1989) noch die Arten *D. crassa* (Michaelsen, 1900), *D. clujensis* Pop, 1938, *D. pseudorosea* Moreno, 1983, *D. ruffoi* Zicsi, 1970, *D. osellai* Zicsi, 1970, *D. mrazeki* (Cernovitov, 1935) zugeordnet. Obwohl *D. auriculata* und *D. mrazeki* doppellappige Nephridialblasen besitzen, können sie wegen des gefiederten Muskeltyps nicht in diese Gattung gestellt werden, da *calarensis*, die Typusart, den bündelförmigen Typ besitzt. *D. clujensis* und *D. crassa* verfügen unseres Wissens über keine zweilappigen Nephridialblasen.

Im vorliegenden Material liegen von zwei verschiedenen Fundorten einige Exemplare vor, die in diese Gattung eingereiht werden können. BOUCHÉ (1972) meint zur Beschreibung von *K. calarensis* Tetry zwar, dass es sich um eine polymorphe Art handeln soll, führt jedoch klare Bestimmungsmerkmale an, allein die Drüsenpapillen scheinen stark zu variieren. Unsere Tiere, die etwas nördlich von seinen Fundorten gesammelt wurden, weichen so deutlich von *K. calarensis* ab, dass wir sie als neue Arten für die Wissenschaft betrachten.

### **Kritodrilus tetryae sp. n.**

Fundort: Holotypus. G/2660. Dept. de l'Ain, 1 km vor d Oncieu, 330 m., 25. 3. 1989 leg Haymoz. Paratypen. AF/12298 2 +1 juv. Ex., G/2667 2Ex.

Diagnose: L. 75-115 mm, B. 7,8-8,4 mm, Segmentzahl 238-278. Unpigmentiert, weiss. Kopf prolobisch. Borsten eng gepaart. Gürtel vom 26., 27.-37., Pubertätsstreifen vom 1/2 31., 32.-36., 1/2 37. Segment. Dissepimente 5/6-9/10 verdickt. Herzen im 6.-11., Kalkdrüsen im 11. Segment. Perioesophageale Testikelblasen im 10. und 11. Segment. 2 Paar Samensäcke im 11. und 12. Segment. Typhlosolis dreifach gelappt. Nephridialblasen doppellappig. Muskulatur bündelförmig. 2 Paar Samentaschen im 11. und 12. Segment.

Länge des Holotypus 75 mm, Breite 8 mm, Segmentzahl 245. Paratypen. Länge 70 -115 mm. Breite 7,8-8,4 mm. Segmentzahl 238-278.

Farbe weiss, unpigmentiert. Kopf prolobisch. 1. Segment längsgefurcht, Segmente vom 9. doppelt oder mehrfach gefurcht. Borsten ungepaart, Borstenverhältnis hinter dem Gürtel aa:ab:bc:cd:dd wie 3:2,5:2,4:1:4. Erster Rückenporus auf Intersegmentalfurche 5/6. Nephridialporen oberhalb der Borstenlinie b, nicht alternierend. Vier grosse Drüsenpölster auf dem 11. und 30., auf dem 14. und 29. drei, auf dem 16. und 28. Segment zwei, sie umgeben entweder die Borsten ab, oder nur a. Allein auf dem 11. Segment sind die mächtigen Pölster konstant, auf den übrigen kommen sie variierend vor. Samentaschenporen auf Intersegmentalfurche 10/11 und 11/12 in der Borstenlinie c. Weibliche Poren auf dem 14. Segment, männliche Poren auf dem 15. Segment von grossen Drüsenhöfen umgeben, die benachbarten Segmente ausbreitend, ohne auf diese überzugehen. Gürtel sattelförmig vom 26., 37.-37. Segment, Pubertätsstreifen vom 1/2 31., 32.-36., 1/2 37.

Innere Organisation. Dissepimente 5/6-9/10 sehr stark, 10/11-11/12 nur schwach verdickt. Schlundkopf bis in 5. Segment reichend. Herzen im 6.-11. Segment. Kalkdrüsen im 11. Segment mit kleinen Ausbuchtungen. Hoden und Samentrichter im 10. und 11. Segment in perioesophageale, aufgefranzte Testikelblasen eingeschlossen. 2 Paar Samensäcke im 11. und 12. Segment, ungefähr gleich-grosse Gebilde, die auf ihre Segmente beschränkt sind. Ovarien im 13. Segment, mit reifen Eiern gefüllt, grosse Ovarientrichter auf Dissepiment 13/14. Kropf im 15.-16. Segment, Muskelmagen im 17.-19. Segment. Thyphlosolis vom 20. Segment beginnend, dreifach gelappt, weit nach hinten reichend. Nephridialblasen im Hinterkörper doppellappig.

Samentaschen 2 Paar im 11. und 12. Segment kleine, runde, sessile Gebilde.

*K. tetryae* unterscheidet sich von *K. calarensis* durch die Lage des Gürtels und der Pubertätsstreifen sowie durch die Zahl der Samentaschen.

Die neu Art wird zu Ehren von Frau A. Tétry benannt, die sich grosse Verdienste in der Erkundung der Regenwurmfauna Frankreichs erworben hat.

### **Kritodrilus micrurus** sp. n.

Fundort: Holotypus. G/2661. Dépt. de la Drôme. Coriencon prés de Vinsobres, 21. 6. 1984. Paratypus Z/12145 1 praead. Ex. Fundort wie beim Holotypus.

Diagnose: L. 45-54 mm, B. 1,5-2 mm, Segmentzahl 138-148. Unpigmentiert, weiss. Kopf prolobisch. Borsten eng gepaart. Gürtel vom 26.-35., Pubertätsstreifen vom 1/4 30.-1/2 35. Segment. Dissepimente 5/6-9/10 verdickt. Herzen im 6.-11., Kalkdrüsen im 11. Segment. Perioesophageale Testikelblasen im 10. und 11. Segment. 2 Paar Samensäcke im 11. und 12. Segment. Typlosolis dreifach gelappt. Nephridialblasen doppellappig. Muskulatur bündelförmig. 3 Paar Samentaschen im 10., 11., 12. Segment.

Länge des Holotypus 54 mm, Breite 2 mm, Segmentzahl 148. Paratypus. Länge 45 mm, Breite 1,5 mm, Segmentzahl 138.

Farbe weiss, unpigmentiert. Kopf prolobisch. Vordere Segmente ungeringelt, vom 9. doppelt geringelt. Borsten ungepaart. Borstenverhältnis hinter dem Gürtel aa:ab:bc:cd:dd wie 3,3:2:1,3:1:6,6. Grosse Polsterdrüsen auf den Borsten ab des 13.,

auf der Borste a des 16., und 17., auf den Borsten aa des 25. Segments. Auf dem Gürtel fehlen diese Pölster, die Borsten aa des 28.-30. Segments werden nur von kleinen runden Papillen umgeben. Beim praeadulten Exemplar sind keine Pölster vorhanden. Rückenporus auf Intersegmentalfurche 11/12 beginnend. Nephridialporen in der Borstenlinie b nicht alternierend. Samentaschenporen auf Intersegmentalfurche 9/10, 10/11, 11/12 in der Borstenlinie c. Gürtel sattelförmig vom 26.-35. Segment, Pubertätsstreifen vom 1/4 30.-1/2 35. Segment. Weibliche Poren auf dem 14. Segment, männliche Poren auf dem 15. Segment, von grossen Drüsenhöfen umgeben.

Innere Organisation. Dissepimente 5/6-9/10 stark verdickt. Herzen im 6.-11. Segment. Kalkdrüsen im 11. Segment mit kleinen Ausbuchtungen. Hoden und Samenrichter im 10. und 11. Segment in perioesophageale Testikelblasen eingeschlossen. Samensäcke im 11. und 12. Segment. Ovarien im 13. Segment, Ovarientrichter auf Dissepiment 13/14. Kropf im 15. und 16., Muskelmagen im 17.-1/2 20. Segment. Typhlosolis im 20. Segment beginnend, dreifach gelappt. Nephridialblasen hinter dem Gürtel doppellappig. Muskulatur bündelförmig. Samentaschen 3 Paar im 10., 11., 12. Segment als kleine, runde, sessile Gebilde, von vorne nach hinten grösser werdend.

Die neue Art steht *K. calarensis* und *K. tetryae* sp. n. am nächsten, unterscheidet sich von ihnen durch die Lage des Gürtels, und der Pubertätsstreifen, von *K. tetryae* auch durch die Zahl der Samentaschen.

### **Dendrodrilus** Omodeo, 1956

*Dendrodrilus* Omodeo, 1956: 175

Durch die weitgepaarten Borsten, durch die Ausbuchtungen der Kalkdrüsen im 10. Segment, den gefiederten Muskeltyp und die U-förmigen Nephridialblasen, deren Ausführungen nach vorne gerichtet sind, unterscheidet sich *Dendrodrilus* von allen bisher beschriebenen Gattungen der Familie Lumbricidae.

### **Dendrodrilus rubidus rubidus** (Savigny, 1826)

Fundorte: Nr. 1/1. G/1109 1 Ex., Nr. 1/6. G/1463 1 Ex., Nr. 1/7. G/1445 1 Ex., Nr. 4/1. G/961 1 Ex., Nr. 4/2. G/982 9 Ex., Nr. 6. G/1440 1 Ex., Nr. 8/2. G/1458 2 Ex., Nr. 9/7. G/1779 1 Ex., Nr. 16/2. G/1438 1 Ex., Nr. 21/5. G/1808 2 Ex., Nr. 28/1. G/1775 1 Ex., Nr. 30. G/1469 2 Ex., Nr. 39/1. G/1781 1 Ex., Nr. 44. G/2057 2 Ex., Z/9830 3 Ex., Nr. 63. 12514 1 Ex.

### **Dendrodrilus rubidus subrubicundus** (Eisen, 1874)

Fundorte: Nr. 1/2. G/1105 4 Ex., Z/9334 5 Ex., Nr. 7/5. G/1884 1 Ex., Nr. 10. G/1672 1 Ex., Z/9566 2 Ex., Nr. 25. G/1416 1 Ex., Nr. 26. G/1913 8 Ex., Nr. 33. G/1596 8 Ex., G/1630 1 Ex., G/1636 2 Ex., Z/9546 2 Ex., Nr. 37. G/1689 13 Ex., Z/9597 15 Ex., Nr. 39/1. G/1782 1 Ex., Nr. 42. G/2040 1 Ex.

### **Dendrobaena** Eisen, 1873

#### **Dendrobaena attemsi** (Michaelsen, 1902)

Fundorte: Nr. 37. G/1691 1 Ex., Z/9599 1 Ex.

**Dendrobaena octaedra octaedra** (Savigny, 1826)

Fundorte: Nr. 9/7. G/1802 6 Ex., Nr. 26. G/1914 2 Ex., Nr. 34. G/1619 1 Ex., Z/9553 2 Ex., Nr. 36. G/1652 2 Ex., Nr. 37. G/1692 1 Ex., Z/9600 2 Ex., Nr. 56/1. Z/12554 2 Ex., Nr. 57. Z/12493 1 Ex., Nr. 60. Z/12502 2 Ex., Nr. 62. Z/12511 1 Ex., Nr. 69. Z/12537 2 Ex., Nr. 70/1. Z/12543 3 Ex., Nr. 74. Z/12562 1 Ex., Nr. 77. Z/12576 45+5 Ex.

**Dendrobaena octaedra quadrivesiculata** Pop, 1938

Fundorte: Nr. 49. G/1944 10.Ex., Nr. 56/1. Z/12554 2 Ex., Nr. 57. Z/12493 1 Ex., Nr. 58. Z/12500 2 Ex., Nr. 60. Z/12502 2 Ex., Nr. 62. Z/12511 1 Ex., Nr. 63. Z/12513 2 Ex., Nr. 69. Z/12537 2 Ex., Nr. 70. Z/12543 1 Ex., Nr. 77. Z/12576 45 Ex.

Diese bisher nur aus Siebenbürgen, Moldawien und Muntenien (Rumänien) aus höheren Gebirgslagen gemeldete Unterart (POP 1938) wurde von BOUCHÉ (1972) in verschiedenen Teilen Frankreichs gesammelt. Wir haben sie nur in den Pyrenäen gesammelt. Sie unterscheidet sich eindeutig durch die 4 Paar Samensäcke von der Stammform.

**Dendrobaena cognettii** (Michaelsen, 1903)

Fundort: Nr. 74. Z/12561 5 Ex.

Bei den von uns angetroffenen Exemplaren liegt der Gürtel vom 33.-37. Segment, wie dies bei den meisten von uns früher erbeuteten Tieren der Fall ist (ZICSI 1981).

**Satchellius** Gates, 1975

*Satchellius* Gates, 1975a: 4, EASTON 1983: 484, SIMS & GERARD 1985: 118, MRSIC 1991: 667.

Typusart: *Enterion mammale* Savigny, 1826.

Weitere Arten: *Satchellius madeirensis* (Michaelsen, 1891), *S. alvaradoi* Moreno, 1982.

Diese Gattung umfasst rotpigmentierte Arten mit weitgepaarten Borsten und Kalkdrüsen im 10. Segment sowie würstchenförmigen Nephridialblasen und gefiederter Muskulatur. Sie ist innerhalb der Familie Lumbricidae gut abgegrenzt.

**Satchellius mammalis** (Savigny, 1826)

Fundorte: Nr. 25. G/1419 5 Ex., Z/9344 5 Ex., Nr. 33. G/1639 50 Ex., Z/9534 50 Ex., Z/9535 35 Ex., Nr. 34. G/1618 3 Ex., Z/9550 5 Ex., Nr. 35. G/1581 8 Ex., Z/9538 12 Ex., Nr. 42. G/2032 6 Ex., Z/9810 9 Ex.

**Aporrectodea** Örley, 1885

*Aporrectodea* Örley, 1885: 22.

*Allolobophora* Pop, 1941:20.

*Allolobophora* (*Allolobophora*), OMODEO 1956: 180, ZICSI 1982: 444.

*Nicodrilus* (part.), BOUCHÉ 1972: 315, PEREL 1979: 206.

*Aporrectodea*, GATES 1975a: 4, SIMS & GERARD 1985: 53, MRSIC 1991: 27.

Typusart: *Aporrectodea trapezoides* Ant. Dugès, 1928.

Die von Gates wieder ins Leben gerufene Gattung Örleys hat das Problem der Sammelgattung *Allolobophora* nicht gelöst, es werden ihr Arten mit J-bis U-förmigen Nephridialblasen mit nach hinten gerichtetem Ausführungsgang zugeordnet, ohne Rücksicht auf andere, grundlegende Merkmale wie Typ der Muskulatur und Lage der Kalkdrüsen.

Wir reihen einstweilen nur die bislang zur Gattung *Allolobophora* gestellten Arten zu *Aporrectodea*, die wie die Typusart gefiederte Muskulatur besitzen und bei denen die Nephridialblasen J-U-förmig und nach hinten gerichtet sind.

### ***Aporrectodea caliginosa caliginosa* (Savigny, 1826)**

Fundorte: Nr. 1/2. G/1103 3 Ex., Nr. 1/3. G/988 2 Ex., Nr. 1/5. G/1452 2 Ex., Nr. 1/6. G/1467 4 Ex., Nr. 1/7. G/1448 1 Ex., Nr. 1/9. G/1649 5 Ex., G/1650 4 Ex., Nr. 6. G/1442 2 Ex., Nr. 7/1. G/1592 13 Ex., G/1593 8 Ex., Z/9508 9 Ex., Z/9509 3 Ex., Nr. 7/2. G/1613 6 Ex., G/1614 2 Ex., Z/9523 3 Ex., Nr. 7/3. G/1767 13 Ex., G/1772 10 Ex., G/1773 10 Ex., Z/9644 11 Ex., Z/9647 10, Ex., Nr. 7/4. G/1599 7 Ex., G/1600 20 Ex., Z/9615 9 Ex., Z/9517 3 Ex., Nr. 7/6. G/2010 2 Ex., Nr. 8/1. G/996 6 Ex., G/997 7 Ex., Nr. 8/2. G/1460 21 Ex., Z/9325 4 Ex., Nr. 9/1. G/1415 5 Ex., Nr. 9/2. G/1427 1 Ex., Nr. 9/3. G/1112 7 Ex., Nr. 9/4. G/1115 1 Ex., Nr. 9/5. G/1423 4 Ex., Nr. 9/7. G/1777 3 Ex., Nr. 10. G/1674 1 Ex., Z/9565 1 Ex., Nr. 11/3. G/2029 1 Ex., Nr. 16/1. G/1099 1 Ex., Nr. 19. G/980 2 Ex., Nr. 21/1. G/1664 1 Ex., Z/9559 2 Ex., Nr. 21/2. G/1671 1 Ex., Nr. 21/3. G/1655 1 Ex., G/1657 2 Ex., Nr. 23. G/987 2 Ex., Nr. 24. G/989 1 Ex., Nr. 25. G/1420 2 Ex., Z/9342 1 Ex., Z/9343 1 Ex., Nr. 26. G/1918 3 Ex., Nr. 32. G/1784 2 Ex., Nr. 33. G/1641 3 Ex., Z/9530 2 Ex., Nr. 38. G/2355 1 Ex., Nr. 39/2. G/2348 2 Ex., Z/10770 6 Ex., Nr. 41. G/2165 4 Ex., Z/10655 3 Ex., Nr. 42. G/2038 2 Ex., Z/9812 15 Ex., Nr. 43. G/1855 1 Ex., Nr. 44. G/2055 4 Ex., Z/9826 1 Ex., Z/9827 13 Ex., Nr. 45. G/2060 1 Ex., Z/9833 2 Ex., Nr. 47. G/1939 3 Ex., Z/9773 43 ex., Z/9771 2 Ex., Nr. 53. G/2067 2 Ex., Z/9849 3 Ex., Nr. 54. G/1937 3 Ex., Z/9765 4 Ex., Nr. 55. G/1942 1 Ex., Z/9776 1 Ex., Nr. 56. G/2061 7 Ex., Z/9837 10 Ex., Nr. 57. Z/12483 14 Ex., Nr. 63. Z/12516 1 Ex., Nr. 66. Z/12520 1+7 Ex., Nr. 68. Z/12530 2 Ex., Nr. 70/1. Z/12541 4 Ex., Nr. 76. Z/12575 1 Ex.

### ***Aporrectodea caliginosa trapezoides* (Ant. Dugès, 1828)**

Fundorte: Nr. 41. G/2166 2 Ex., Z/10656 2 Ex., Nr. 43. G/1854 1 Ex., Nr. 56. G/2062 2 Ex., Z/9836 2 Ex., Nr. 58. Z/12498 1 Ex.

### ***Aporrectodea longa* (Ude, 1885)**

Fundorte: Nr. 1/6. G/1464 3 Ex., Nr. 1/9. G/1651 1 Ex., Nr. 9/1. G/1414 1 Ex., Nr. 9/3. G/1113 2 Ex., Nr. 9/4. G/1117 3 Ex., Nr. 1661. G/1100 1 Ex., Z/9340 2 Ex., Nr. 19. G/978 1 Ex., Nr. 42. G/2039 2 Ex., Z/9813 4 Ex.

### ***Aporrectodea terrestris* (Savigny, 1826)**

Fundorte: Nr. 7/3. G/1771 35 Ex., Z/9640 5 Ex., Z/9641 5 Ex., Z/9642 5 Ex., Nr. 21/1. G/1663 2 Ex., Z/9560 1 Ex., Nr. 31. G/1801 2 Ex., Nr. 44. G/2054 3 Ex., Z/9825 2 Ex.

### ***Aporrectodea cupulifera* Tétry, 1937**

Fundorte: Nr. 21/1. G/1662 1 Ex., Nr. 33. G/1640 4 Ex., Nr. 35. G/1576 15 ex., G/1577 10 Ex., Z/9537 26 Ex., Nr. 41. G/2160 8 Ex., Z/10651 21 Ex.



**Aporrectodea haymozi** Zicsi, 1977

Fundorte: Nr. 58. G/2557 1+1 juv. Ex., Z/12496 4+1 Ex., Nr. 60. 12501 2+1 Ex., Nr. 70/1. 12540 7 Ex.

Die Überprüfung des Typenmaterials zeigte, dass die Lage der Samentaschen in den Originalbeschreibung falsch angeführt wurde: sie liegen im 12., 13. und 14. Segment und münden auf Intersegmentalfurche 11/12, 12/13 und 13/14 aus. Die Nephridialblasen sind fast U-förmig und nach hinten gerichtet. Bei den jetzt erbeuteten Tieren erstreckt sich der Gürtel vom 33.-/2 40., 40. Segment, die Pubertätsstreifen liegen am 35., 36. - 40.

**Aporrectodea haymoziformis** sp. n.

Fundorte: Holotypus, Z/12949. Dép. Pyrénées-Atlantiques. Camou-Cihigue, 14. 9. 1982. leg. A. Zicsi. Paratypen, Z/12950 1 Ex., Z/9845 3 Ex., G/2066 1 +1 juv. Ex.

Diagnose : L. 49-56 mm, B. 3,5-42 mm, Segmentzahl 102-117. Unpigmentiert, weiss. Kopf prolobisch. Borsten eng gepaart. Gürtel vom 1/2 33., 33., 34.-40., 1/2 41. Segment. Dissepimente 6/7-11/12 verdickt. Herzen im 6.-11., Kalkdrüsen im 10. Segment. Hoden und Samentrichter frei. 4 Paar Samensäcke im 9.-12. Segment. Typhlosolis einfach gelappt. Nephridialblasen U-förmig. Muskulatur gefiedert. 4 Paar Samentaschen im 11., 12., 13., 14. Segment.

Länge des Holotypus 52 mm, Breite 4 mm, Segmentzahl 109. Paratypen. Länge 49-56 mm, Breite 3,5-42 mm, Segmentzahl 102-117.

Farbe weiss. Kopf prolobisch. 1. Segment gefurcht, die übrigen ungeringelt. Borsten eng gepaart. Borstenverhältnis hinter dem Gürtel aa:ab:bc:cd:dd wie 6:1:3:1:9. Borsten ab und cd auf dem 11. Segment, cd auf dem 12., 13., 14. Segment, sowie ab auf dem 31. und 32. Segment von kleinen Papillen umgeben. Die Borsten ab entlang der Pubertätsstreifen sind ebenfalls von kleinen Papillen umgeben. Erster Rückenporus auf Intersegmentalfurche 9/10. Nephridialporen in der Borstenlinie cd, nicht alternierend. 4 Paar Samentaschenporen auf Intersegmentalfurche 10/11, 11/12, 12/13 und 13/14. Gürtel sattelförmig vom 1/2 33., 33., 34.-40., 1/2 41., Segment. Pubertätsstreifen 1/2 34., 34. -40., 1/2 41. Segment.

Innere Organisation. Dissepimente 6/7-9/10 stark, 10/11-11/12 weniger stark verdickt. Schlund bis ins 6. Segment reichend. Herzen im 6.-11. Segment. Kalkdrüsen nur kleine Ausbuchtungen im 10. Segment. Hoden und Samentrichter im 10. und 11. Segment frei. 4 Paar Samensäcke im 9.-12. Segment, die im 9. und 10. klein, im 11. und 12. Segment grösser und gelappt. Ovarien im 13. Segment, Ovarientrichter auf Dissepiment 13/14. Nephridien hinter dem Gürtel U-förmig nach hinten gebogen. Kropf im 15.-16. Segment, Muskelmagen im 17.-18. Segment, Typhlosolis einfach gelappt. Muskulatur gefiedert.

Samentaschen kleine runde Gebilde ohne Stiel im 11., 12., 13. und 14. Segment, mit Samenmassen prall gefüllt.

Die neue Art steht *A. haymozi* am nächsten. Unterscheidet sich von ihr durch die Lage der Pubertätsstreifen und die höhere Zahl der Samentaschen.

**Aporrectodea riparia** (Bretcher, 1901)

Fundort: Nr. 44. G/2056 1 Ex.

Die Art ist neu für die Fauna Frankreichs.

**Aporrectodea icterica** (Savigny, 1826)

Fundorte: Nr. 1/9. G/1647 1 Ex., Nr. 7/1. G/1588 20 Ex., Z/9512 11 Ex., Nr. 7/2. G/1611 5 Ex., Nr. 7/3. G/1763 16 Ex., Z/9643 16 Ex., Nr. 7/4. G/1602 16 Ex., Z/9521 1 Ex., Nr. 7/6. G/2008 1 Ex., Z/9807 2 Ex., Nr. 9/7. G/1776 1 Ex.

**Aporrectodea rosea** (Savigny, 1826)

Fundorte. Nr. 1/6. G/1466 1 Ex., Nr. 1/7. G/1446 1 Ex., Nr. 1/9. G/1648 1 Ex., Nr. 7/1. G/1586 13 Ex., Nr. 7/2. G/1616 6 Ex., Nr. 7/3. G/1765 4 Ex., Z/9645 3 Ex., Nr. 7/4. G/1604 2 Ex., Nr. 7/6. G/2009 1 Ex., Nr. 8/2. G/1459 4 Ex., Z/9324 3 Ex., Nr. 9/3. G/1111 1 Ex., Nr. 9/7. G/1778 1 Ex., Nr. 15/1. G/1122 1 Ex., Nr. 21/1. G/1660 2 Ex., Nr. 21/3. G/1656 1 Ex., Nr. 21/4. G/1790 2 Ex., Nr. 43. G/1848 1 Ex., Nr. 56/1. Z/12553 3 Ex., Nr. 57. Z/12485 1 Ex., Nr. 58. Z/12497 2 Ex., Nr. 75. Z/12565 6 Ex., Nr. 76. Z/12574 1 Ex., Nr. 77. Z/12577 1 Ex.

**Allolobophora** Eisen, 1874Typusart: *Enterion chloroticum* Savigny, 1826**Allolobophora chlorotica chlorotica** (Savigny, 1826)

Fundorte: Nr. 1/1. G/1471 1 Ex., Nr. 1/2. G/1102 5 Ex., Z/9337 6 Ex., Nr. 1/5. G/1451 2 Ex., Nr. 1/6. G/1471 1 Ex., Nr. 1/7. G/1447 3 Ex., Nr. 1/9. G/1645 10 ex., Nr. 1/10. G/1679 8 Ex., Nr. 6. G/1441 17 Ex., Nr. 7/1. G/1587 12 Ex., Z/9513 9 Ex., Nr. 7/2. G/1615 10 Ex., Z/9524 3 Ex., Nr. 7/3. G/1764 10 Ex., G/1766 1 Ex., Z/9646 6 Ex., Nr. 7/4. G/1603 10 Ex., Z/9519 12 Ex., Nr. 7/6. G/2007 4 Ex., Nr. 8/1. G/993 2 Ex., Nr. 8/2. G/1461 6 Ex., Z/9323 4 Ex., Nr. 9/1. G/1413 2 Ex., Nr. 9/3. G/1110 2 Ex., Nr. 9/4. G/1114 4 Ex., Nr. 10. G/1673 1 Ex., Z/9564 5 Ex., Nr. 11/2. G/1887 1 Ex., Nr. 11/3. G/2030 1 Ex., Nr. 13. G/964 1 Ex., Nr. 14. G/1774 1 Ex., Nr. 19. G/979 9 Ex., Nr. 20. G/1880 3 Ex., Nr. 21/1. G/1661 1 Ex., Z/9557 2 Ex., Nr. 21/4. G/1791 1 Ex., Nr. 24. G/990 1 Ex., Nr. 25. G/1421 6 Ex., Z/9341 4 Ex., Nr. 31. G/1800 4 Ex., Nr. 32. G/1785 1 Ex., Nr. 33. G/1629 1 Ex., G/1638 16 Ex., Z/9532 14 Ex., Nr. 34. G/1620 2 Ex., Nr. 35. G/1583 10 Ex., Z/9541 29 Ex., Nr. 38. G/2354 4 Ex., Nr. 39/2. G/2349 2 Ex., Z/1077 1 Ex., Nr. 41. G/2164 7 Ex., Z/10654 4 Ex., Nr. 42. G/2035 6 Ex., Z/9816 12 Ex., Nr. 43. G/1849 3 Ex., Nr. 44. G/2051 2 Ex., Z/9819 3 Ex., Nr. 47. G/1938 7 Ex., Z/9770 1 Ex., Nr. 48. G/1946 1 Ex., Z/9784 5 Ex., Nr. 55. G/1941 1 Ex., Z/9775 1 Ex., Nr. 56. G/2063 1 Ex., Z/10654 4 Ex., Nr. 56/1. 12555 1 Ex.

**Allolobophora chlorotica postpheba** Bouché, 1972

Fundorte: Nr. 20. G/1881 8 Ex., Nr. 35. G/1585 1 Ex., Nr. 43. G/1850 8 Ex.

**Allolobophoridella** Mrsic, 1990*Lumbricus* (part.), LEVINSSEN 1884: 241.*Dendrobaena* (part.), OMODEO 1956: 156.*Bimastus* (part.), OMODEO 1956: 178.*Eisenia* (part.), BOUCHÉ 1972: 378, ZICSI 1982: 428.*Allolobophora* (part.), PEREL 1979: 186, EASTON 1983: 475, ZICSI 1994: 69.*Allolobophoridella* Mrsic, 1990: 252.Typusart: *Lumbricus eiseni* Levinsen, 1884.

**Allolobophoridella eiseni** (Levinsen, 1884)

Fundorte: Nr. 4/2. G/984 1 Ex., Nr. 44. G/2058 1 Ex., Z/9820 3 Ex., Nr. 57. Z/12515 4 Ex., Nr. 63. Z/12484 2 Ex.

Die zeitweise in 5 verschiedene Gattungen gestellte Art zeigt die Unsicherheit, mit der einige Arten der Familie Lumbricidae behandelt wurden. Wir schliessen uns der von MRSIC (1991) vorgeschlagenen Gattungsdefinition (rotpigmentierte Arten mit Nephridien, deren Ausführungsgang nach vorne gerichtet ist) an, mit der Bemerkung, dass allein die Typusart, die über gefiederten Muskeltyp verfügt, in dieser Gattung bekannt ist. Zur zweiten Art von MRSIC mit bündelartigem Muskeltyp (*A. parva* Eisen, 1874) können wir vorerst nicht Stellung nehmen.

**Eisenia** Malm, 1877

Typusart: *Enterion fetidum* Savigny, 1826.

**Eisenia fetida** (Savigny, 1826)

Fundorte: Nr. 1/2. G/1104 1 Ex., Nr. 2. G/1454 21 Ex., Nr. 26. G/1917 7 Ex., Nr. 27. G/2028 1 Ex., Nr. 33. G/1595 10 Ex., G/1635 1 Ex., Z/9544 10 Ex., Nr. 34. G/1622 15 Ex., Nr. 36. G/1653 1 Ex., Nr. 42. G/2036 6 Ex., Z/9815 10 Ex., Nr. 68. Z/12529 1+2 Ex.

Der Artenname *fetidum* wurde von MICHAELSEN (1900) in *foetidum* emendiert und Jahrzehnte hindurch so benützt. Da dies die Regeln der Nomenklatur nicht zulassen, muss die alte Schreibweise wieder eingeführt werden.

**Eisenia lucens** (Waga, 1857)

Fundort: Nr. 63. Z/12512 3 Ex.

**Eiseniella** Michaelsen, 1900**Eiseniella tetraedra tetraedra** (Savigny, 1826)

Fundorte: Nr. 5. G/1680 1 Ex., Nr. 11/2. G/1886 25 Ex., Nr. 16/1. G/1098 2 Ex., Nr. 33. G/1631 5 Ex., G/1637 10 Ex., Z/9533 1 Ex., Z/9548 1 Ex., Nr. 34. G/1624 9 Ex., Z/9551 1 Ex., Nr. 35. G/1578 15 Ex., Z/9536 50 Ex., Nr. 41. G/2163 10 Ex., Z/10653 8 Ex., Nr. 57. 12488 5 Ex., Nr. 58. 12499 1 Ex., Nr. 61. 12506 1 Ex., Nr. 68. 12528 7 Ex., Nr. 72. 12527 1 Ex.

**Eiseniella tetraedra hercynia** (Michaelsen, 1890)

Fundort: Nr. 33. G/1643 1 Ex.

**Octolasion** Örley, 1885**Octolasion cyaneum** (Savigny, 1826)

Fundorte: Nr. 1/2. G/1107 1 Ex., Z/9335 1 Ex., Nr. 1/6. G/1468 1 Ex., Nr. 1/7. G/1443 2 Ex., Nr. 1/9. G/1646 1 Ex., Nr. 8/2. G/1455 3 Ex., Z/9321 1 Ex., Nr. 9/7. G/1780 1 Ex., Nr. 15/1. G/976 1 Ex., Nr. 20. G/1883 2 Ex., Nr. 38. G/2356 3 Ex., Nr. 39/2. G/2351 2 Ex., Z/10773 1 Ex., Nr. 41. G/2159 2 Ex., Nr. 42. G/2034 4 Ex., Z/9811 6 Ex., Nr. 43. G/1851 1 Ex., Nr. 44. G/2050 1 Ex.

**Octolasion lacteum** (Örley, 1881)

Fundorte: Nr. 11/2. G/1888 1 Ex., Nr. 20. G/1882 3 Ex., Nr. 23. G/986 1 Ex., Nr. 33. G/1628 1 Ex., G/1642 1 Ex., Z/9527 1 Ex., Nr. 35. G/1584 4 Ex., Z/9543 3 Ex., Nr. 43. G/1852 5 Ex., Nr. 44. G/2049 1 Ex., Z/9817 1 Ex., Nr. 56. G/2064 1 Ex., Z/9838 1 Ex., Nr. 56/1. Z/12552 15 Ex., Nr. 57. Z/12486 3 Ex., Nr. 60. Z/12503 1 Ex., Nr. 63. Z/12517 1 Ex., Nr. 68. Z/12531 2+1 Ex., Nr. 69. Z/12536 2 Ex., Nr. 74. Z/12563 3 Ex., Nr. 75. Z/12567 8 Ex.

**Orodrilus** Bouché, 1972

*Orodrilus* Bouché, 1972: 219, EASTON 1982: 484

Typusart: *Allolobophora doderoi* Cognetti, 1904.

Diese auf Meroandrie der männlichen Geschlechtsorgane aufgestellte Gattung, lässt sich durch die eng bis weitläufig gepaarten Borsten, durch den gefiederten Muskeltyp und die nach hinten gerichteten J-förmigen Nephridialblasen von den übrigen Gattungen unterscheiden. Für die meroandrischen Arten der Gattungen *Octodrilus* und *Octodriloides* sind keine gesonderten Gattung aufgestellt worden, da hier andere Begrenzungsmerkmale, wie die Lage der männlichen Poren, ungepaarte Borsten und die Zahl der Samentaschen, ausschlaggebend waren. Wir schliessen uns der Meinung von Bouché an und betrachten die meroandrischen Arten, mit den weiter oben angeführten Merkmalen, als dieser Gattung angehörend.

**Orodrilus gavernicus** (Cognetti, 1904)

Fundort: Nr. 69. Z/12948 1 Ex.

**Proselodrilus** Bouché, 1972

*Proselodrilus* Bouché, 1972: 231, EASTON 1983: 484, MRSIC 1991: 662.

Typusart: *Proselodrilus idealis* Bouché, 1972.

Durch den stark nach vorne gerückten Gürtel (am 19., 20. Segment beginnend), die eng gepaarten Borsten, die fehlende Pigmentation, die hinter dem Gürtel doppellappigen Nephridialblasen und der bündelförmigen Muskulatur sowie durch die doppeltgelappte Typhlosolis unterscheidet sie sich von allen übrigen Gattungen.

**Proselodrilus pyrenaicus** (Cognetti, 1904)

Fundort: Nr. 42. G/2033 1 Ex.

**Proselodrilus albus** sp. n.

Fundort. Dept. Haute-Garonne, Holotypus. Z/13003 Audressein (42° 55' 34" N: 1° 01' 1" O) 500 m. 27. 6. 1997 leg. Zicsi-Csuzdi-DFK.

Paratypen, Z/12569 3+5 praed.+1 juv. Ex.- G/2662 2+ 1 praed. Ex. Fundort wie beim Holotypus.

Diagnose: L. 78-83 mm, B. 3,2-4 mm, Segmentzahl 134-184. Unpigmentiert, weiss. Kopf prolobisch. Borsten eng gepaart. Gürtel vom 20.-27., Pubertätsstreifen vom 20.-1/4 25. Segment. Dissepimente 5/6-8/9 verdickt. Herzen im 6.-11., Kalkdrüsen im 11. Segment. Perioesophageale Testikelblasen im 10. und 11. Seg-

ment. 2 Paar Samensäcke im 11. und 12. Segment. Typhlosolis doppelt gelappt. Nephridialblasen doppellappig. Muskulatur bündelförmig. 2 Paar Samentaschen im 14. und 15. Segment.

Länge des Holotypus 83 mm, Breite 4 mm, Segmentzahl 184. Paratypen. Länge 78-81 mm, Breite 3,2-3,8 mm, Segmentzahl 134-178.

Farbe weiss, unpigmentiert. Kopf prolobisch. 1. Segment längsgefurcht, vom 7. doppelt und mehrfach gefurcht. Borsten eng gepaart. Borstenverhältnis hinter dem Gürtel aa:ab:bc:cd:dd wie 20:1:5:1:30. Borsten ab des 12., 14., 16. sowie die des 25.-33. Segments von winzigen Papillen umgeben. Erster Rückenporus auf Intersegmentalfurche 4/5. Nephridialporen oberhalb der Borstenlinie b, nicht alternierend. Samentaschenporen auf Intersegmentalfurche 13/14 und 14/15 unterhalb der Borstenlinie cd. Weibliche Poren auf dem 14. Segment, männliche Poren auf dem 15. Segment, von einem kleinen Hof umgeben, der nicht auf das 16. Segment übergeht.

Gürtel sattelförmig auf dem 20.-27. Segment, Pubertätsstreifen vom 20.-/4 25. Segment.

Innere Organisation. Dissepimente 5/6-8/9 sehr stark, 9/10 nur schwach verdickt. Schlund bis ins 5. Segment reichend. Herzen im 6.-11. Segment. Kalkdrüsen im 11. Segment. Hoden und Samentrichter im 10. und 11. Segment von perieosophagealen Testikelblasen umgeben. Ausführungsgang der Samenrinne nicht gewunden. 2 Paar Samensäcke im 11. und 12. Segment. Ovarien im 13. Segment. Ovarientrichter auf Dissepiment 13/14. Kropf im 15.-16. Segment, Muskelmagen im 17-19. Segment. Mitteldarm im 20. Segment mit einer doppeltgelappten Typhlosolis versehen. Nephridien hinter dem Gürtel doppellappig. Muskulatur bündelförmig.

Samentaschen 2 Paar im 14. und 15. Segment, kleine gebogene, birnförmige Ampulle mit kurzem Ausführungsgang. Der Ausführungen der Samentaschen dicht von Drüsen umgeben.

Die neue Art steht *P. pyrenaicus* am nächsten. Sie unterscheidet sich von ihr durch die Lage des Gürtels und der Pubertätsstreifen.

### **Prosellodrilus fragilis fragilis** Bouché, 1972

Fundort: Nr. 69. Z/12533-34 38 juv. Ex.

Keines der zahlreichen Tiere besass einen entwickelten Gürtel, allein die Pubertätsstreifen liessen sich erkennen, aufgrund deren Lage ist das Material mit Vorbehalten zu *fragilis fragilis* gestellt worden.

### DANKSAGUNG

Für die Ermöglichung der Sammelreise in die Pyrenäen (1997) sowie für einen Arbeitsplatz im Naturhistorischen Museum von Genf, wo auch ein Teil des neueren Materials bearbeitet wurde, sprechen wir der Direktion des Museums und Herrn Dr. Cl. Vaucher unseren besten Dank aus.

## LITERATUR

- BOUCHÉ, M. B. 1970. Remarques sur quelques Lumbricina de France et conséquences de la découverte des nouveaux taxons Vignysinae (Subfam. nov.) et Diporodrilidae (Fam. nov.). *Pedobiologia* 10:246-256.
- BOUCHÉ, M. B. 1972. Lombriciens de France. Écologie et systématique. *Institut National de la Recherche Agronomique, Articles de Zoologie-Écologie animale* (Numéro hors-série). 671 pp.
- DIAZ COSIN, D., TRIGO, D. & MASCATO, R. 1992. Earthworms of the Iberian Peninsula. Species list and some biographical considerations. *Soil Biology and Biochemistry* 24:1351-1356.
- EASTON, E. G. 1983. A guide to the valid names of Lumbricidae (Oligochaeta) (pp. 475-485). In: SATCHELL, J. E. (ed.). Earthworm ecology from Darwin to vermiculture. *Chapman and Hall, London*.
- GATES, G. E. 1975a. Contributions to a revision of the earthworm family Lumbricidae. XII. *Enterion mammale* Savigny, 1826 and its position in the family. *Megadrilogica* 2(1): 1-8.
- GATES, G. E. 1975b. Contributions to a revision of the earthworm family Lumbricidae. XVII. *Allolobophora minuscula* Rosa, 1906 and *Enterion pygmaeum* Savigny, 1826. *Megadrilogica* 2(6): 7-8.
- GATES, G. E. 1978. The earthworm genus *Lumbricus* in North America. *Megadrilogica* 3(6): 81-116.
- GERARD, B. M. 1964. A synopsis of the British Lumbricidae Synopses of the British Fauna No. 6. Lumbricidae (Annelida). *The Linnean Society of London*, 58 pp.
- HOFFMEISTER, W. 1845. Übersicht aller bis jetzt bekannten Arten aus der Familie der Regenwürmer. *Friedrich Vieweg und Sohn, Braunschweig*. 43 pp.
- LEVINSEN, G. M. R. 1884. Systematik-geografisk oversigt over de nordiske Annulata, Gephyrea, Chaetognathi, og Balanoglossi. *Videnskabelige Meddelelser fra Dansk Naturhistorisk Forening i Kjobenhavn*, 1883: 92-350.
- MICHAELSEN, W. 1900. Oligochaeta. *Das Tierreich* 10: 1-575.
- MRSIC, N. 1990. Description of a new subgenus, three new species and taxonomic problems of the genus *Allolobophora* sensu Mrsic and Sapkarev, 1988 (Lumbricidae, Oligochaeta). *Bioloski Vestnik, Ljubljana* 38(1): 49-68.
- MRSIC, N. 1991. Monografija o dezevnikih (Lumbricidae) Balkana I-II. *Academia Scientiarum et Artium Slovenica, Classis IV: Historia Naturalis, Opera* 31: 1-757.
- MULDAL, S. 1952. A new species of earthworms of the genus *Allolobophora*. *Proceedings of the Zoological Society, London* 122: 463-465.
- MURCHIE, W. R. 1959. Redescription of *Allolobophora muldali* Omodeo, 1956 (Lumbricidae: Oligochaeta). *The Ohio Journal of Science* 59(6): 329-332.
- OMODEO, P. 1953. Nota su alcuni lombrichi delle Alpi e considerazioni sul Gen. *Helodrilus* di Hoffmeister. *Memorie del Museo Civico di Storia Naturale di Verona* 4: 75-85.
- OMODEO, P. 1956. Contributo alla revisione dei Lumbricidae. *Archivio Zoologico Italiano* 41: 129-143.
- OMODEO, P. 1988. The genus *Eophila* (Lumbricidae, Oligochaeta). *Bolletino di Zoologia Napoli* 55: 73-84.
- OMODEO, P. & ROTA, E. 1989. Earthworms of Turkey. *Bolletino di Zoologia Napoli* 56: 167-199.
- ÖRLEY, L. 1885. A palearktikus övben élő Terricoláknak revíziója és elterjedése. *Értekezések a természettudományok Köréből, Budapest* 15: 1-34.
- PEREL, T. S. 1976. A critical analysis of the Lumbricidae genera system (with key to the USSR fauna genera). *Revue d'Ecologie et de Biologie du Sol* 13(4): 635-643.

- PEREL, T. S. 1979. Range and regularities in the distribution of earthworms of the USSR fauna (with keys to the Lumbricidae and other Megadrili). *Nauka, Moskow*. 272 pp.
- PICKFORD, G. E. 1926. On a new species of earthworm belonging to the subgenus *Bimastus* from Wicken Fen. *The Annals and Magazine of Natural History London* 17: 96-98.
- POP, V. 1938. Neue Lumbriciden aus Rumänien. *Buletinul Societății de Științe din Cluj* 9: 134-152.
- POP, V. 1941. Zur Phylogenie und Systematik der Lumbriciden. *Zoologische Jahrbücher* 74 (5-6): 487-522.
- ROSA, D. 1906. *L'Allolobophora minuscula* n. sp. *Atti della Società dei Naturalisti e Matematici di Modena* (4)7: 38-39.
- SIMS, R. & GERARD, B. M. 1985. Earthworms Keys and notes for the identification and study of the species. *Synopses of British Fauna* 31: 171 pp.
- TRIGO, D., MASCATO, R., IGLESIAS BRIONES, M. J. & DIAZ-COSIN, D. J. 1990. Lombrices de tierra de Portugal Continental. Inventario y Cytas. *Arquivos do museu Bocage, Nov. Ser.* 1: 521-567.
- ZICSI, A. 1968. Neuere Angaben zur Kenntnis der Lumbricidenfauna Jugoslawiens. *Annales Universitatis Scientiarum Budapestiensis de Rolando Eötvös Nominatae, Sectio Biologica, Budapest* 9-10: 401-405.
- ZICSI, A. 1973. Regenwürmer (Oligochaeta: Lumbricidae) aus Griechenland. *Opuscula Zoologica, Budapest* 12: 99-103.
- ZICSI, A. 1977a. Wiederbeschreibung zweier Arten aus der Familie Lumbricidae (Oligochaeta). *Opuscula Zoologica, Budapest* 13: 107-110.
- ZICSI, A. 1977b. Neue Regenwürmer (Oligochaeta: Lumbricidae) aus den Atlantischen Pyrenäen. *Revue suisse de Zoologie* 84: 681-685.
- ZICSI, A. 1981. Weitere Angaben zur Lumbricidenfauna Italiens (Oligochaeta: Lumbricidae). *Opuscula Zoologica, Budapest* 17-18: 157-180.
- ZICSI, A. 1982. Verzeichnis der bis 1971 beschriebenen und revidierten Taxa der Familie Lumbricidae (Oligochaeta). *Acta Zoologica Hungarica* 28: 421-454.
- ZICSI, A. 1985. Über die Gattungen *Helodrilus* Hoffmeister, 1845 und *Proctodrilus* gen. n. (Oligochaeta: Lumbricidae). *Acta Zoologica Hungarica* 31: 275-289.
- ZICSI, A. 1986. Über die taxonomischen Probleme der Gattung *Octodrilus* Omodeo, 1956 und *Octodriloides* gen. n. (Oligochaeta: Lumbricidae). *Opuscula Zoologica, Budapest* 22: 103-112.
- ZICSI, A. 1994. Die Regenwürmer Österreichs (Oligochaeta: Lumbricidae) mit Bestimmungstabellen der Arten. *Verhandlungen der Zoologisch-Botanischen Gesellschaft in Österreich* 131: 37-74.
- ZICSI, A. & MICHALIS, K. 1981. Übersicht der Regenwurm-Fauna Griechenlands (Oligochaeta: Lumbricidae). *Acta Zoologica Hungarica* 27: 239-264.





## **A review of the Himalayan *Thorectes* (Coleoptera: Geotrupidae), with description of a new species from northern India**

Giuseppe M. CARPANETO

Università degli Studi "Roma Tre", Dipartimento di Biologia,  
Viale G. Marconi, 446, I-00146 Roma, Italia.

Roberto MIGNANI

Università degli Studi "Roma Tre", Dipartimento di Fisica "E. Amaldi",  
Via della Vasca Navale, 84, I-00146 Roma, Italia.

**A review of the Himalayan *Thorectes* (Coleoptera: Geotrupidae), with description of a new species from northern India.** - *Thorectes shankara* sp. n. from West Himalayas is described and illustrated. A checklist of the Himalayan species of *Thorectes* is given, including detailed records. A key to these species is provided and their diagnostic characters are summarized. Metathoracic wings are strongly but not completely reduced in these species. The wing reduction in *Thorectes* is discussed.

**Key-words:** Coleoptera - Geotrupidae - Himalayas - India - wing size - taxonomy.

### INTRODUCTION

In the framework of a worldwide generic revision of Geotrupinae, ZUNINO (1984) raised *Thorectes* Mulsant, 1842 from subgenus of *Geotrupes* Latreille, 1796 to genus, with 36 species included. The genus has discontinuous distribution, with 32 Mediterranean species, one (*T. banghaasi* Reitter, 1893) endemic in Gissar and Darvaz Mountains in Tajikistan (NIKOLAJEV 1987), and three from Nepal Himalayas (BARAUD 1974, KRICKEN 1981). The Nepalese species are: *T. nepalensis* Baraud, 1974, *T. martensi* Krikken, 1981 and *T. stellosus* Krikken, 1981. Two subspecies are recognized in the latter species. New collections from the Indian part of the western Himalayas include an additional species of *Thorectes* which is described below.

### ***Thorectes shankara* sp. n.**

*Holotype*: ♂, India, Uttar Pradesh, Kedarnath 3300 m a.s.l. (14 kms north of Rambara), 26-29 July 1994, M. Snizek leg. *Paratypes*: 13 ♂♂ and 22 ♀♀, all from the type locality.

*Holotype* in Zoological Museum of Rome University (MZUR); 5 paratypes in the Carpaneto collection; 2 paratypes (1 ♂, 1 ♀) in the "Muséum d'histoire naturelle de Genève"; 2 paratypes (1 ♂, 1 ♀) in the "Forschungsinstitut Senckenberg, Frankfurt am Main"; remaining specimens in the Mignani collection.

*Diagnosis:* Allied to *T. nepalensis* (figs 1, 3, 15) but distinguished by the following characters: (1) third external tooth of protibia directed downwards (fig. 2); (2) 7 teeth, instead of 6, along outer margin of protibia (fig. 2); (3) 8-9 denticles, instead of 7, along ventral face of protibia (fig. 2); (4) pronotum more strongly convex; (5) pronotal surface shining, elytral surface sericeous; (6) elytral striae partially effaced but all moderately distinct; (7) mesosternal apophysis pointed anteriorly (on lateral view); (8) disc of metasternum and of abdominal sternites glabrous and almost impunctate; (9) apex of parameres wider and more rounded, slightly turned downwards (fig. 4).

*Description of the holotype:* Male, length 17.5 mm, greatest width 8.7 mm. Entirely black. Moderately shining but elytra opaque with sericeous aspect. Antennal club brownish black.

Clypeus (length 3.7 mm) widely U-shaped. Clypeal surface densely and roughly punctate. Clypeal margin slightly raised. Disc with obsolete central elevation. Eye normally shaped, eye-canthus broadly rounded, with anterolateral angle subdistinct. Clypeo-frontal sulcus V-shaped, fronto-lateral ridge moderately pronounced. Labrum with anterior margin feebly emarginate and sides rounded. Left mandible with shallow apical external emargination. Right mandible with protruding lobe near apical-external emargination.

Pronotum (length 5 mm) strongly convex, with maximum width (8.7 mm) at posterior half, entirely marginate, except for posterior edge on both sides of antescutellar section of base. Pronotal contours with anterior angle ca. 100°, posterior angle rounded. Pronotal punctation very fine, formed by small and minute punctures (as in *T. nepalensis*), and widely scattered all over surface. Scutellum broadly triangular (length 1 mm). Elytra convex (maximum length 8.7 mm; maximum width 8.7), humeral angle rounded, with umbone distinct. Elytral striae irregular and moderately distinct. Surface opaque with sericeous aspect due to microreticulation. Wings strongly reduced (micropterous): wing length 2.6 mm. WL/EL (wing length/elytral length) 0.3. Mesosternal apophysis pointed anteriorly (on lateral view); mesosternal cavity deep. Metasternum with very shallowly impressed midline. Disc of metasternum and of abdominal sternites glabrous and almost impunctate.

Protibia with 7 teeth along outer margin, apical tooth bifid; third external tooth directed downwards; inferior longitudinal crest with 9 denticles (fig. 2). Metafemur with irregular series of 6-7 denticles, some notched, decreasing in size towards apex (fig. 5).

Apex of parameres wide and rounded, slightly turned downwards (in *T. nepalensis*, parameres have apex narrower, more pointed, and distinctly directed upwards) (figs 3-4).

*Paratype variability:* Male length: 15-18.4 mm; male width: 7.7-9.1 mm. Female length: 12.5-18.6 mm; female width: 6.1-9.5 mm. In males, the shape and the number of the denticles on the posterior margin of the metafemur are highly variable (figs 5-12); a certain degree of variability is also observed in the inferior denticulation of protibia.

Sexually-dimorphic characters are as those usual in other Himalayan *Thorectes* species. Females differ by: (1) apical tooth of protibia simple (not bifid); (2) protibia

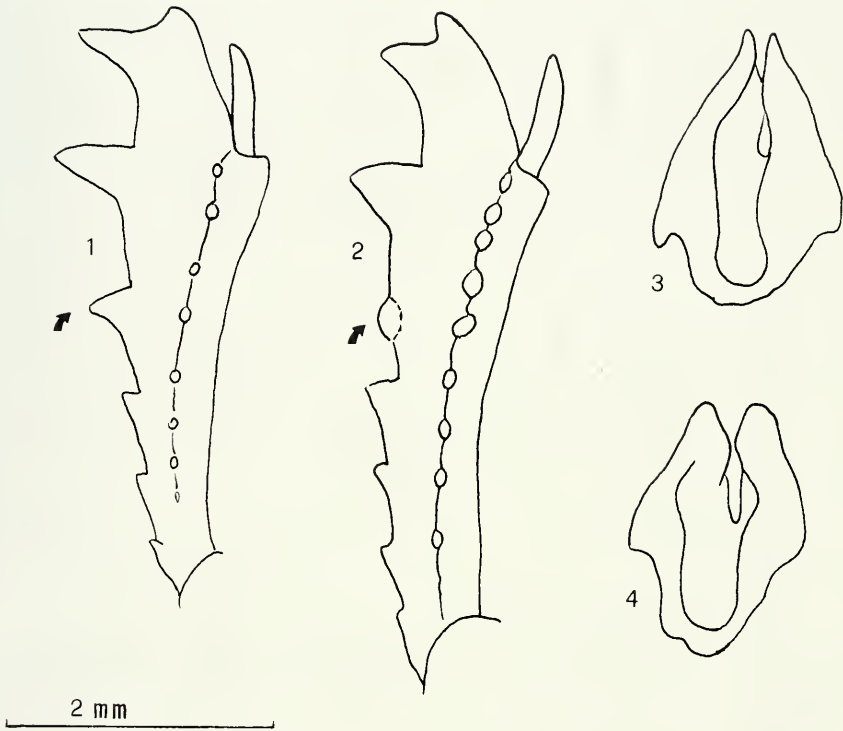

FIGS 1-4

*Thorectes nepalensis* (holotype): 1, underside of protibia; 3, ventral view of parameres. *Thorectes shankara* sp. n. (holotype): 2, underside of protibia; 4, ventral view of parameres. The arrows in figs 1-2 indicate the third external tooth of tibia.

without inferior crest of denticles; (3) metafemur without denticles; (4) pronotum less convex and narrower, with a slightly denser punctation.

*Ecological notes:* According to the collector, Miroslav Snizek, the specimens were captured in pitfall traps (with fish as bait), during several rainy days, on the western slope of a mountain near to Kedarnath. The slope was covered by a mixed forest, slightly damaged by cutting.

*Etymology:* This species is named to honour the Indian philosopher Shankara (dead at Kedarnath about 750 AD).

#### CHECKLIST OF THE HIMALAYAN THORECTES

A checklist of the Himalayan species and subspecies of the genus *Thorectes* is here given together with the material examined and distribution, including the altitudinal range. The main diagnostic characters are compared in Table 1.

TABLE 1 - Diagnostic characters of the Himalayan species and subspecies of *Thorectes*.

Characters	<i>T. martensi</i>	<i>T. shankara</i>	<i>T. nepalensis</i>	<i>T. stellosus</i> s. str.	<i>T. s. annapurnicus</i>
Pronotal punctures	dense, well impressed	sparse, fine	sparse, fine	large, well impressed	large, feebly impressed
Pronotal surface (male)	shiny, anteriorly flat	shiny, strongly convex	shiny	opaque, wrinkled	opaque, wrinkled
External teeth of male protibia	7	7	6	7	5 or 6
Ventral denticles of male protibia	5 or 6	8 or 9	7	8 or 9	8 or 9
Extra ventral tooth of male protibia	absent	absent	absent	present	present
Elytral surface	shiny	sericeous	shiny	opaque, wrinkled	opaque, wrinkled
Elytral striae	distinct	partially effaced	effaced	effaced	partially effaced
Mesosternal apophysis	pro-w-shaped	pointed	pro-w-shaped	pointed	pointed
Metasternal disc	strongly punctate, glabrous	impunctate, glabrous	punctate, setose	punctate, setose	punctate, setose
Disc of abdominal sternites	punctate, glabrous	impunctate, glabrous	punctate, setose	punctate, setose	punctate, setose
Male metafemur	unidentate	multidentate	multidentate	multidentate	multidentate

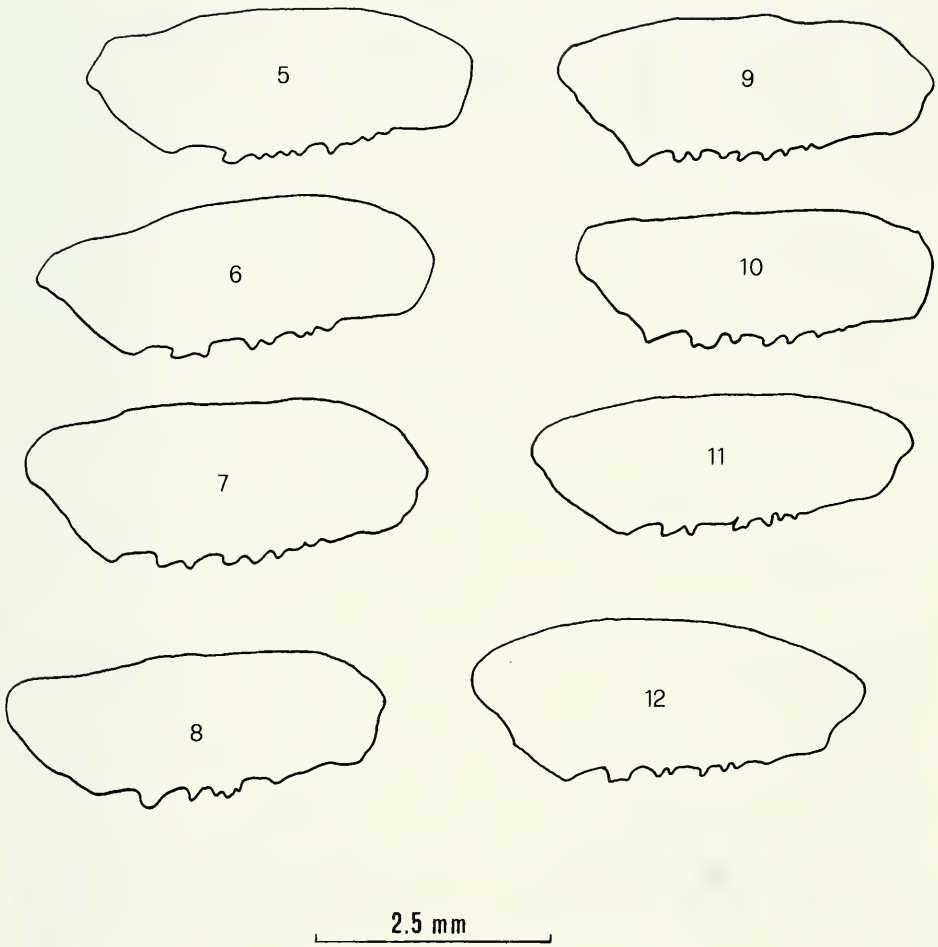

FIGS 5-12

Variation of denticles on posterior margin of metafemur in males of *Thorectes shankara* sp. n. (12, holotype).

*T. martensi* Krikken, 1981

Material examined: Paratype ♂, Nepal, S-Dhaulagiri, Dhorpatan, 3000-3200 m, 7-25 May 1973, Expedition Jochen Martens (Forschungsinstitut Senckenberg, Frankfurt am Main, Germany).

Distribution: Nepal, S-Dhaulagiri, 3000-3600 m a.s.l.

*T. shankara* sp. n.

Material examined: See description, type material.

Distribution: India, Uttar Pradesh, 3300 m a.s.l.

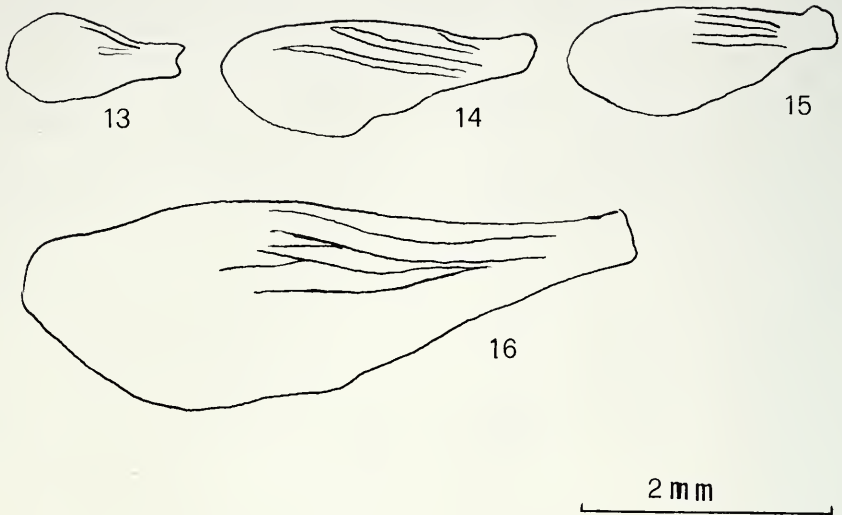

Figs 13-16

Wing size in Himalayan species of the genus *Thorectes*: 13, *T. martensi*; 14, *T. shankara*; 15, *T. nepalensis*; 16, *T. stellosus*.

*T. nepalensis* Baraud, 1974

Material examined: Holotype ♂, Nepal, Katmandu, Miss. USHQ, 1953 (Muséum d'histoire naturelle de Genève). 1 ♂, Nepal, Karnali zone, Churchi Lagna, N Jumla, 3400 m, 26 June-2 July 1995, Ahrens & Pommeranz leg. (G. Carpaneto collection).

Distribution: W and C Nepal, 2300-3400 m a.s.l.

*T. stellosus stellosus* Krikken, 1981

Material examined: Paratype ♂, Nepal, S-Dhaulagiri, Bobang, S of Dhorpatan, 2500 m, April 1970, Expedition Jochen Martens; Paratype ♀, (idem) (both in Forschungsinstitut Senckenberg, Frankfurt am Main, Germany).

Distribution: Nepal, S-Dhaulagiri (only known from type locality).

*T. stellosus annapurnicus* Krikken, 1981

Material examined: Paratype ♂, Nepal, S-Annapurna, Gorapani Pass, 2750-2900 m, 24-28 July 1970, Expedition Jochen Martens; Paratype ♀ (idem) (both in Forschungsinstitut Senckenberg, Frankfurt am Main, Germany).

Distribution: Nepal, S-Annapurna (only known from type locality).

KEY TO HIMALAYAN SPECIES AND SUBSPECIES OF THE GENUS *THORECTES*

1. Elytra without distinct striae. Inferior crest of male metafemora multi-dentate (Figs 5-12). Pronotum normally convex . . . . . 2
- Elytra with moderately distinct striae. Inferior crest of male metafemora at most with a single small tooth. Pronotum flattened anteriorly . . . . . *martensi*
2. Upper surface smooth. Pronotum shiny, with fine punctures. Male protibiae with multidentate inferior crest (Figs 1-2) . . . . . 3
- Upper surface wrinkled. Pronotum opaque, with large punctures. Male protibiae with multidentate inferior crest and one non-aligned additional tooth 4
3. Third external tooth of male protibiae directed downwards (Fig. 2); elytral surface sericeous; disc of metasternum and of abdominal sternites glabrous and almost impunctate . . . . . *shankara*
- Third external tooth of male protibiae directed outwards (Fig. 1); elytral surface shining like pronotum; disc of metasternum and abdominal sternites punctate and setose . . . . . *nepalensis*
4. Dorsum coarsely wrinkled, pronotum with well impressed, star-like punctures; western form (Dhaulagiri area) . . . . . *stellosus stellosus*
- Dorsum finely wrinkled, pronotum with feebly impressed punctures; eastern form (Annapurna area) . . . . . *stellosus annapurnicus*

## DISCUSSION

According to ZUNINO (1984) two lineages occur within the genus *Thorectes*: the first including most of the Mediterranean/south-European species and *T. banghaasi* from Tajikistan; the second one including the Himalayan species and two western Mediterranean species (*T. geminatus* Gené, 1839 and *T. punctatissimus* Chevrolat, 1840). Subsequently, LOPEZ-COLON (1989) splitted the genus *Thorectes* into four subgenera: *Thorectes* Mulsant, 1942; *Zuninoe* Lopez-Colon, 1989; *Jekelius* Lopez-Colon, 1989; *Silphotrupes* Jekel, 1866. The last was originally conceived by JEKEL (1866) to group species having the apical tooth of male protibia simple and clypeus semielliptic (*T. punctatissimus* and *T. escorialensis* Jekel, 1866), but LOPEZ-COLON placed here species which ZUNINO (1984) considered related to *T. punctatissimus*, i.e. *T. geminatus* and the Himalayan species. However, the latter ones were not examined by LOPEZ-COLON (1989), and therefore his conclusions were based on descriptions only. Thus, his subgeneric arrangement needs to be confirmed after a more comprehensive revision.

The new species is closely related to *T. nepalensis*, as suggested by the shape of male genitalia. The presence of teeth on posterior margin of male metafemora is a character shared by some geotrupid genera which are very distant among them as well as belonging to different tribes (e.g., *Thorectes* among Geotrupini, *Chromogeotrupes* Bovo & Zunino, 1983, and *Phelotrupes* Jekel, 1866, among Chromogeotrupini). Within the genus *Thorectes*, this character also occurs in *T. geminatus*, *T. valencianus*, and *T. distinctus*; but only 5 species (*T. valencianus*, *T. geminatus*, *T. nepalensis*, *T. stellosus* and *T. shankara*) show a true denticulation (not a single tooth), i.e. a series of small teeth along the posterior margin of metafemur.

The genus *Thorectes* was so far considered to comprise wingless species (BOUCOMONT 1905; BARAUD 1966a, 1966b). In order to check this character state, we dissected several species, including all members of the subgenus *Silphotrupes*, and the type species of other subgenera. Actually, all members of *Thorectes* show wing reduction and sometimes complete absence of wings. We have calculated the ratio WL/EL (wing length/elytral length) to evaluate the meiopterism degree according to the classification used by BIONDI (1993) for Chrysomelidae Alticinae. The WL/EL may vary from micropterous to subapterous condition: only *T. geminatus* resulted to be apterous; *T. shankara* shows a 0.3 value of the ratio and is considered micropterous; all other species examined have extremely reduced hind wing (WL/EL < 0.3) and so belong to the subapterous group. Wings of Himalayan species are shown in figs. 13-16.

#### ACKNOWLEDGEMENTS

We are grateful to the following specialists and museum curators: I. Löbl, Muséum d'histoire naturelle de Genève (Switzerland); D. Kovac and A. Vesmanis, Forschungsinstitut Senckenberg, Frankfurt am Main (Germany); E. Sprecher, Naturhistorisches Museum, Basel (Switzerland); M. Snizek and Ales Bezdek (Praha); D. Ahrens, Staatliches Museum für Tierkunde, Dresden (Germany). Special thanks are due to M. Bologna (Department of Biology, University "Roma Tre") for useful discussions and a critical reading of the manuscript.

#### REFERENCES

- BARAUD, J. 1966a. Révision du sous-genre *Thorectes* Mulsant (Col. Scarabaeoidea) (1e note): les espèces ibériques. *Eos* 41: 181-198.
- BARAUD, J. 1966b. Révision du sous-genre *Thorectes* Mulsant (Col. Scarabaeoidea) (3e note): les espèces d'Europe (sauf Péninsule ibérique) et du Moyen-Orient. *Annales de la Société Entomologique de France* (n.s.) 2 (3): 563-575.
- BARAUD, J. 1974. Révision du sous-genre *Thorectes* Mulsant (Col. Scarabaeoidea) (7e note). Les espèces asiatiques. *Bulletin de la Société Entomologique de France* 79: 123-125.
- BOUCOMONT, A. 1905. Etude sur les *Euoplotrupes* et *Geotrupes* d'Asie. *Revue d'Entomologie* (1904): 209-252.
- BIONDI, M. 1993. Revisione del sottogenere *Asiolestia* Jacobson s. str. (Coleoptera, Chrysomelidae, Alticinae). *Bollettino del Museo Civico di Storia Naturale di Verona* 17 (1990): 1-56.
- JEKEL, H. 1866. Essai sur la classification naturelle des *Geotrupes* Latreille et description d'espèces nouvelles. *Annales de la Société Entomologique de France* (4) 5: 513-618.
- KRIKKEN, J. 1981. Geotrupidae from the Nepal Himalayas. New flightless species of *Geotrupes* Latreille 1796, with a biogeographical discussion (Insecta: Coleoptera). *Senckenbergiana Biologica* 61 (1980): 369-381.
- LOPEZ COLON, J. I. 1989. Algunas consideraciones sobre la morfología de la armadura genital masculina en el género *Thorectes* Mulsant, 1842 y sus implicaciones filogenéticas (Col. Scarabaeoidea, Geotrupidae). *Boletín Grupo Entomológico de Madrid* 4: 69-82.
- NIKOLAJEV, G. 1987. The scarab beetles (Coleoptera, Scarabaeoidea) of Kazahstan and Central Asia. *Academy of Sciences of Kazahstan, Alma Ata*, 232 pp. (in Russian).
- ZUNINO, M. 1984. Sistematica generica dei Geotrupinae (Coleoptera, Scarabaeoidea: Geotrupidae). Filogenesi della sottofamiglia e considerazioni biogeografiche. *Bollettino del Museo Regionale di Scienze Naturali di Torino* 2 (1): 9-162.



## The identity of *Glomeris quadrifasciata* C. L. Koch (Diplopoda: Glomeridae)

René HOESS & Adolf SCHOLL

University of Berne, Institute of Zoology, Division of Population Biology,  
Baltzerstr. 3, CH-3012 Berne.

**The identity of *Glomeris quadrifasciata* C. L. Koch (Diplopoda: Glomeridae).** - The synonymy of *Glomeris quadrifasciata* C. L. Koch, 1847, with *G. undulata* C. L. Koch, 1844, recognized by VERHOEFF (1931), is confirmed. *Glomeris oblongoguttata* Verhoeff, 1894, stat. n. is the valid name for *Glomeris quadrifasciata* sensu VERHOEFF (1911) from South Tyrol. This taxon is classified as a species closely related to *G. transalpina* C. L. Koch, 1836, by VERHOEFF (1911). Allozyme electrophoretic data agree with morphological results. Possible glacial refugia and postglacial colonization, which might explain the actual distribution of *G. oblongoguttata* and *G. transalpina*, are discussed. Specific separation of both taxa is concluded to have happened before the Pleistocene (> 1.6 mio years BP).

**Key-words:** Diplopoda - *Glomeris* - revision - allozymes - postglacial colonization - refugia.

### INTRODUCTION

In most diplopods, the gonopods as highly differentiated sclerotized structures have successfully been used for species separation and distinction. *Glomeris*, however, do not have gonopods. The telopods with their syncoxite that are used for copulation (HAACKER 1969) show only minor differences among species and even show variation within some species (e.g. VERHOEFF 1932, 1936a and SCHUBART 1934, *G. undulata* nominate form and f. *conspersa*). In addition, they have never been tested for their qualification as isolating mechanism. Molecular data instead, might be more useful for taxonomic studies in these animals. In fact, allozyme electrophoretic data have recently been successfully used to analyse whether the *Glomeris*-taxa *hexasticha* and *intermedia* are species or subspecies (HOESS *et al.* 1997). Taxonomic studies and revisions in *Glomeris* are complicated by the fact that no type material was indicated in the *Glomeris* literature until the mid of the 20th century. In any case, however, type material cannot be used in allozyme studies because it is usually preserved in ethanol that destroys enzyme activity. We therefore collected new material in the areas of the taxa concerned and we depend for identification on morphological characters, such as

the colour pattern, the grooves on the shield and the shape of the last tergite, that are usually sufficiently outlined in the original descriptions.

For our allozyme-based genetic analysis of the Central European *Glomeris* species, we also sampled a population of *Glomeris quadrifasciata* sensu VERHOEFF (1911) (nec Koch, 1847). We found that the oldest available name for Verhoeff's taxon is *G. oblongoguttata* which was first described as a local variety of *G. transalpina* (VERHOEFF 1894) and later classified as a variety of his *G. quadrifasciata* (VERHOEFF 1911). VERHOEFF (1911) considered his taxon as closely related to *G. transalpina*. This relationship is here confirmed by allozyme data. Furthermore, based on this allozyme data set, we postulate glacial refugia for and postglacial colonization of *G. oblongoguttata* and *G. transalpina*.

## MATERIAL AND METHODS

One population sample of *G. oblongoguttata* (endemic for South Tyrol and the Bergamo Pre-Alps) and eight population samples of *G. transalpina* from large parts of its range were analyzed (number of specimens in brackets): *G. oblongoguttata*: Latsch (17); *G. transalpina*: Pfnwald (19), Simplon (2), Loucherhorn (2), Airolo (13), Brugnasco (16), Albula (11), Lago di Poschiavo (2), Glurns (19). The small samples have been included especially in order to analyse ways of postglacial colonization, they are problematical as population samples for electrophoretic studies, however. The main colour characters which separate *G. oblongoguttata* and *G. transalpina* are shown in Fig. 1, and the distribution of both taxa (compiled from literature) and the localities of the sample sites are given in Fig. 2.

We used routine enzyme electrophoretic methods of our laboratory (cf. SCHOLL *et al.* 1978). Vertical starch gel electrophoresis was conducted using the same buffer systems as before (HOESS *et al.* 1997). 18 enzyme loci were analyzed. The enzymes investigated and the loci scored (in brackets) are: aspartate aminotransferase (Aat-1, Aat-2), glyceraldehyd-3-phosphate dehydrogenase (Gapdh), glucose-6-phosphate isomerase (Gpi), hexokinase (Hk), leucine aminopeptidase (Lap), L-lactate dehydrogenase (Ldh-1, Ldh-2), malate dehydrogenase (Mdh-1, Mdh-2), malic enzyme (Me), mannose-6-phosphate isomerase (Mpi), peptidase (Pep), 6-phosphogluconate dehydrogenase (Pgd6), phosphoglucomutase (Pgm), superoxide dismutase (Sod-1, Sod-2) and sorbitol dehydrogenase (Sodh).

The zymograms were photographed (Polaroid) for reference. We refer to observed electromorphs as alleles which are identified by their electrophoretic mobility (in mm) relative to previously studied species (HOESS *et al.* 1997). We used the BIOSYS-1 programme package (SWOFFORD & SELANDER 1989) for calculation of allele frequencies and data treatment. Using the matrix of Nei's distance (NEI 1978), a phenogram of the populations was created by average linkage cluster analysis (UPGMA).

With the allozyme data, we also tried to test the biological species concept by MAYR & ASHLOCK (1991) where species are defined as groups of interbreeding natural populations that are reproductively isolated from other such groups. For the usability of small samples cf. GORMAN & RENZI (1979).

Heterozygosity was not estimated and tested with Hardy-Weinberg-expectations because most samples were collected in a very small sampling area. *Glomeris* have low individual mobilities. This increases the chance of picking up siblings. The assumptions that underly the Hardy-Weinberg-principle are therefore not given for these samples.

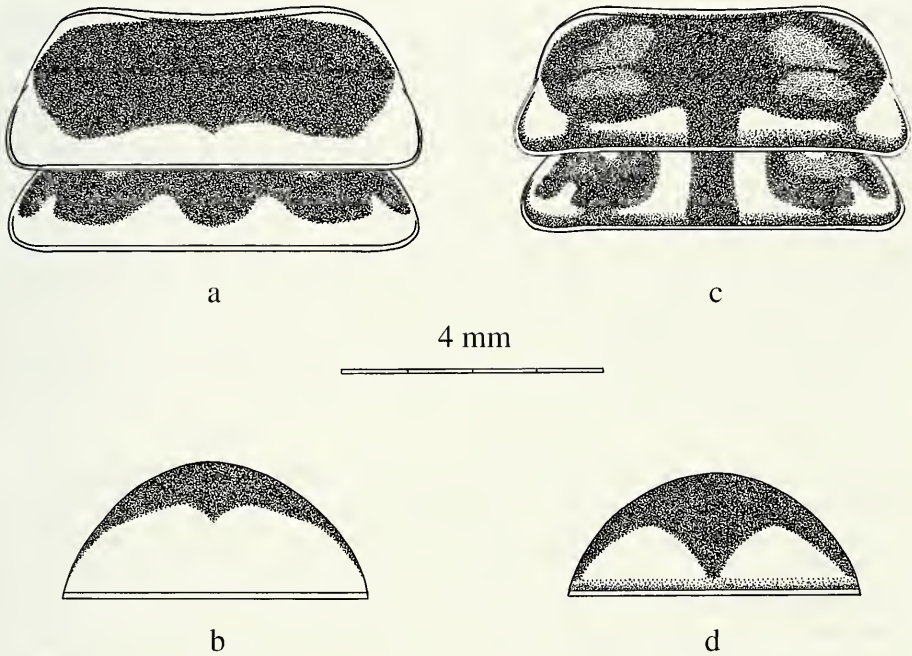

FIG. 1

Colour patterns of *Glomeris transalpina* (a, b) and *G. oblongoguttata* (c, d). Shield (2nd) and 3rd tergite (a, c) (dorsal view) and last (12th) tergite (b, d) (posterior view) (females). Scale: 4 mm.

## TAXONOMY

***Glomeris oblongoguttata*** Verhoeff, 1894 stat. n.

Figs 1 c, d; 2

*Glomeris transalpina* C. L. Koch var. *oblongoguttata* Verhoeff, 1894: 17, Sulden (South Tyrol); VERHOEFF 1902: 180.

*Glomeris transalpina* C. L. Koch var. *spinalemontis* Verhoeff, 1902: 180, Mt. Spinale (South Tyrol); VERHOEFF 1906: 220.

*Glomeris quadrifasciata* C. L. Koch sensu VERHOEFF 1911: 113-114, 139 (nec Koch, 1847); ATTEMS 1927: 255; VERHOEFF 1929: 563; VERHOEFF 1930: 655; VERHOEFF 1931: 429, 433, pl. 7, figs 33, 34 [part]; VERHOEFF 1932: 641; VERHOEFF 1936a: 430; VERHOEFF 1936b: 231; VERHOEFF 1937: 168; STRASSER & MINELLI 1984: 197; FODDAI *et al.* 1995: 12.

*Glomeris quadrifasciata* sensu VERHOEFF (loc. cit.) (nec Koch, 1847) var. *sevini* Verhoeff, 1931: 431, Bergamo Pre-Alps; VERHOEFF 1937: 167.

*Glomeris quadrifasciata* sensu VERHOEFF (loc. cit.) (nec Koch, 1847) var. *brixiensis* Verhoeff, 1931: 432, Brescia (Lombardia).

Diagnosis: Shield with broad yellow-red margins at the outer parts of front and hind edge. Central dark spots on tergites 2-11 parallel-sided or divergent posteriorly. Dark spot on the last tergite triangular, almost reaching the hind edge with the tip. No principal groove but 3-7 accessory grooves on the shield. Last tergite in the male with a notch in the hind margin. Dark pigment always in well defined spots. Speckles often present.

VERHOEFF (1911) designated, with modified and additional characters, *G. quadrifasciata* as a species closely related to *G. transalpina* Koch. *G. quadrifasciata* sensu Verhoeff differs from *G. quadrifasciata* Koch by the following characters: the former has a large, triangular, dark spot on the last tergite that hardly separates the two yellow-red spots, and the shield has a broad yellow-red margin at the outer parts of the hind edge, too (Fig. 1). These characters do not lie within the range of variation of *G. undulata* Koch (see below) to which Koch's *G. quadrifasciata* belongs. This implies that Verhoeff's taxon is a different species. Verhoeff's use of the name *G. quadrifasciata* C. L. Koch is therefore incorrect. VERHOEFF (1931) actually recognized this fact but he did not explicitly rename his taxon.

*Glomeris transalpina* var. *oblongoguttata* Verhoeff, 1894, is the oldest available name for Verhoeff's taxon.

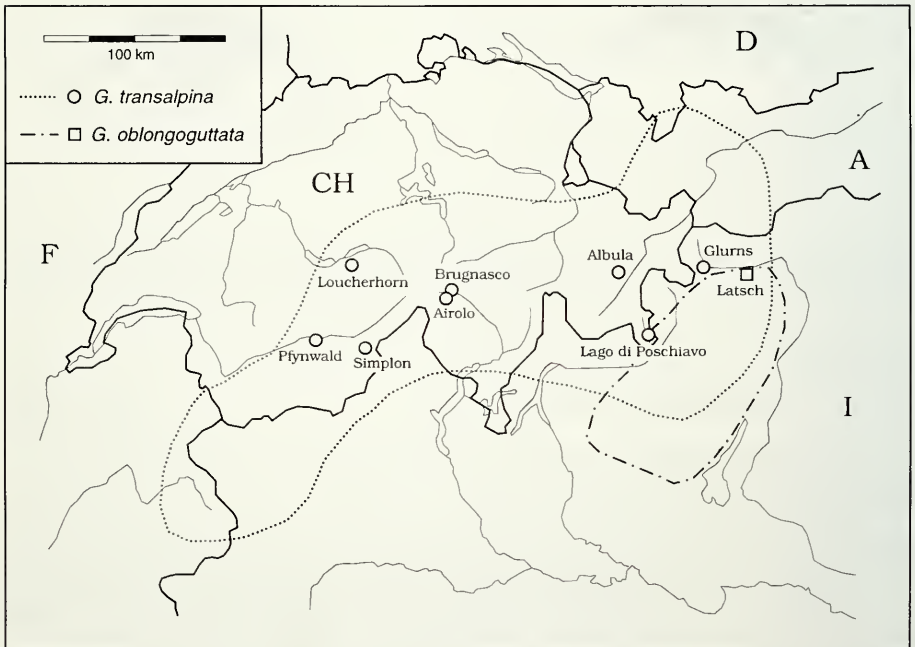

FIG. 2

Distribution (compiled from literature) and sample sites of *Glomeris transalpina* and *G. oblongoguttata*.

***Glomeris undulata* C. L. Koch, 1844**

The synonymy of *G. undulata* presented here is restricted to the names that are needed within the scope of this paper:

*Glomeris undulata* C. L. Koch, 1844: H. 40, pl. 8, South Germany.

*Glomeris conspersa* C. L. Koch, 1847: 89, South Germany [synonymized with *G. undulata* by HOESS & SCHOLL 1999: 657, 659].

*Glomeris quadrifasciata* C. L. Koch, 1847: 91, origin unknown, probably South Germany; C. L. KOCH 1863: 108, pl. 49, figs. 98 a, b, c, one specimen indicated from the museum at Bamberg; VERHOEFF 1931: 433 [part].

*Glomeris tridentina* Latzel, 1884: 118, South Tyrol [synonymized with *quadrifasciata* by VERHOEFF 1902: 177].

*Glomeris conspersa quadrifasciata* C. L. Koch sensu VERHOEFF 1902: 180; VERHOEFF 1906: 166, 177.

*Diagnosis:* Shield with broad yellow to red margins only at the outer parts of the front edge. Central dark spots on tergites 2-12 variable: parallel-sided or divergent posteriorly in the nominate form, convergent posteriorly in f. *conspersa*. No principal groove, except some specimens of f. *conspersa* from the South-eastern Alps which have one, but with 3-4 accessory grooves on the shield. Only some males of nominate form with a notch in the hind margin of the last tergite. Dark pigment next to the central spots usually scattered in speckles, seldom without speckles.

KOCH described (1847, 1863) and illustrated (1863) *Glomeris quadrifasciata*. On the shield, this taxon shows no complete groove (character 1), but it has a broad yellow band (character 2) along the front edge. The last tergite has two large yellow-red spots that are separated by a broad dark band (character 3) which widens towards the front edge. The middle segments show four bands (character 4) of yellow-red spots that are separated in the middle by a dark band made of parallel-sided spots (character 5). Characters 1, 2, 3 and 5 are typical for what is presently recognized as *G. undulata* Koch, whereas character 4 lies within the range of variability of *G. undulata* which is known to be one of the most variable species of the genus. Typically, *G. undulata* shows speckles which are absent in *G. quadrifasciata*. However, there are some varieties of *G. undulata*, that do not express the speckles (see e.g. VERHOEFF 1931: confirmed by own data from electrophoretically analyzed specimens). Consequently, *G. quadrifasciata* does not provide any character for its own. We therefore agree with VERHOEFF (1931) who recognized *G. quadrifasciata* Koch as a synonym of *G. undulata* Koch.

LATZEL (1884) synonymized *G. quadrifasciata* Koch with *G. connexa* Koch. This is not acceptable because the significant characters 1 and 2 are different in *G. connexa* (see also VERHOEFF 1902).

VERHOEFF (1902) first classified *quadrifasciata* as a subspecies of *G. conspersa*; but characters 3, 4 and 5 are different in the latter.

***Glomeris transalpina* C. L. Koch, 1836**

Figs 1a, b; 2; 4

This species shall also be diagnosed here. It was classified as closest related to *G. oblongoguttata* by VERHOEFF (1911) which we confirm by allozyme data later in this paper.



Pep									
104	0.29	-	-	-	-	-	-	-	-
102	0.18	-	-	0.05	0.14	0.27	-	-	-
100	0.53	0.10	-	0.18	0.80	0.61	1	0.50	0.74
98	-	0.40	1	-	0.03	0.04	-	-	0.05
96	-	0.50	-	0.77	0.03	0.08	-	0.50	0.21
Pgd6									
106	-	-	-	-	0.10	0.14	1	-	-
104	0.06	-	-	-	-	-	-	-	-
100	0.94	1	1	1	0.90	0.86	-	1	1
Pgm									
100	-	0.14	-	0.05	0.11	0.35	0.50	-	0.61
97	-	0.86	1	0.95	0.89	0.65	0.50	1	0.39
95	0.05	-	-	-	-	-	-	-	-
93	0.50	-	-	-	-	-	-	-	-
89	0.45	-	-	-	-	-	-	-	-
Sod-2									
100	0.77	0.40	0.50	0.41	0.47	0.46	-	-	0.45
98	-	0.05	0.25	0.36	0.28	0.31	0.75	0.50	0.08
95	0.23	0.29	-	0.05	0.06	0.23	0.25	0.50	0.31
93	-	0.26	0.25	0.18	0.19	-	-	-	0.16
Sodh									
112	-	0.11	-	0.21	0.87	0.62	1	-	0.47
109	0.03	0.52	0.50	-	-	-	-	-	0.03
106	-	0.26	0.50	0.79	0.13	0.38	-	1	0.29
103	-	0.11	-	-	-	-	-	-	0.21
100	0.97	-	-	-	-	-	-	-	-
A	2.22	1.94	1.33	1.61	1.94	1.83	1.33	1.22	1.78
	Val Venosta		Grisons		Ticino		Bernese Alps		Valais

*Diagnosis:* Shield with broad (yellow-)red margins at the outer parts of the front and hind edge. Central dark spots of tergites 2-11 confluent with the remaining dark pigment, convergent posteriorly but not reaching the hind edge. Dark spot on the last tergite triangular but ending far away from the hind edge. No principal groove but 3-4 accessory grooves on the shield. Never a notch in the hind margin of the last tergite. Dark pigment always in well defined spots. Speckles rarely present.

## RESULTS

The alleles observed and their frequencies are listed in Table 1 except for the four loci Aat-2, Lap, Ldh-1 and Sod-1 that were monomorphic, and all populations of both taxa were fixed for the same alleles, viz. Aat-2<sup>100</sup>, Lap<sup>100</sup>, Ldh-1<sup>100</sup> and Sod-1<sup>99</sup>, respectively. Three other loci were monomorphic except for one or two populations, and the same allele was found in both taxa: Locus Gapdh, allele Gapdh<sup>109</sup> (except the *G. transalpina* population from Glurns with one additional allele), locus Gpi, allele Gpi<sup>100</sup> (except the *G. transalpina* population from Pfywald with one additional allele),

and locus *Mpi*, allele *Mpi*<sup>104</sup> (except the *G. transalpina* population from Loucherhorn with one additional allele and the *G. oblongoguttata* population with three additional alleles). Locus *Ldh-2* was monomorphic in all populations of *G. transalpina* (allele *Ldh-2*<sup>82</sup>), the *G. oblongoguttata* population, however, had three alleles that were not observed in *G. transalpina*. The other loci showed high genetic polymorphism. Excluding the populations with small sample sizes ( $N < 10$ ), the average number of alleles per locus (total: 18 loci) was 2.22 in *G. oblongoguttata* and 1.61-1.94 in the *G. transalpina* populations.

*G. oblongoguttata* and *G. transalpina* were clearly genetically distinct by alternative alleles at the loci *Ldh-2* and *Pgm* (Table 1). Additionally, the two geographically closest populations of each taxon namely Latsch and Glurns (distance about 25 km, both localities are in the same valley) showed remarkable differences in the allele frequencies at five other loci. These loci were *Hk*, *Me*, *Mpi*, *Pep* and *Sodh* (Table 1).

Of the 59 alleles recorded at the 18 loci, 21 alleles were found in both taxa, 15 alleles were only observed in *G. oblongoguttata*, and 18 alleles were only observed in *G. transalpina*, 13 of these 18 alleles of *G. transalpina* were widespread in the range of that species.

Several alleles of *G. transalpina* were restricted in their distribution to certain regions (Table 1). At locus *Mdh-1*, the allele *Mdh-1*<sup>105</sup> was only found in Ticino (populations Bruggnasco and Airolo) and Valais (populations Simplon and Pfywald). At locus *Me*, the allele *Me*<sup>102</sup> was fixed or nearly fixed in the three eastern populations (Glurns, Lago di Poschiavo and Albula), it was rare in Ticino and was not present in the three western populations (Loucherhorn, Simplon and Pfywald). This allele is substituted by alleles *Me*<sup>100</sup> and *Me*<sup>98</sup> in the western populations. At locus *Pgd6*, the allele *Pgd6*<sup>106</sup> was only found in the Ticino populations (Bruggnasco and Airolo) and in Loucherhorn.

TABLE 2

Nei-distances *D* in pairwise comparisons of populations of *Glomeris transalpina* and *G. oblongoguttata* (sample sizes > 10).

		<i>G. transalpina</i>				
		Pfywald	Airolo	Bruggnasco	Albula	Glurns
<i>G. transalpina</i>	Airolo	.037				
	Bruggnasco	.038	.020			
	Albula	.158	.098	.120		
	Glurns	.149	.086	.121	.034	
<i>G. oblongoguttata</i>	Latsch	.264	.238	.268	.375	.324

Table 2 shows the genetic distances *D* (Nei 1978) in pairwise comparisons of all populations (sample sizes > 10) using all 18 loci. These distances varied from 0.02 - 0.16 among different populations of *G. transalpina* and from 0.24 - 0.38 among populations of the two taxa.



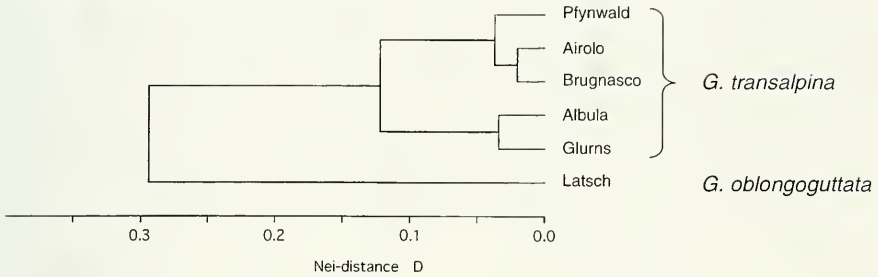

FIG. 3

UPGMA dendrogram using Nei's coefficient of genetic distance for populations of *Glomeris transalpina* and *G. oblongoguttata* (sample sizes > 10).

The Nei distances were graphically transformed into an UPGMA dendrogram (Fig. 3). *G. oblongoguttata* is separated from *G. transalpina* at a distance level of 0.29. The *G. transalpina* populations are found in two subclusters that separate at a distance level of  $D = 0.12$  and contain the Valais and Ticino populations on the one hand and the eastern populations on the other hand.

## DISCUSSION

The most distant populations of *G. transalpina*, Glurns and Pfywald, that are about 225 km apart, share at least one allele at each locus. On the other hand, the closest populations of both taxa (*G. transalpina* population from Glurns and *G. oblongoguttata* population from Latsch) that are found only 25 km apart in the same valley have alternative alleles at two loci (Ldh-2 and Pgm). This indicates that the two taxa belong to different gene pools. This is also supported by five other loci where the allele frequencies between the Latsch and Glurns populations are very different (Hk, Me, Mpi, Pep and Sodh). Specimens with transition in morphological characters that would indicate hybridisation are not known. We therefore conclude that *G. transalpina* and *G. oblongoguttata* are in fact different species. However, these species are closely related. In a previous study (HOESS *et al.* 1997) we found that *G. undulata* (sub *G. conspersa*), which shares characters 1 and 2 (see above) with *G. transalpina*, is genetically more distant to *G. transalpina* than *G. oblongoguttata*.

The locally observed alleles, the allele substitution observed at the Me locus, and the Nei-D values that are graphically interpreted in the dendrogram show two subgroups within *G. transalpina*, an eastern subgroup from Grison and its adjacent valleys, and a western subgroup from Ticino to Valais and the Bernese Alps, respectively. However, there is no reason to assume that these subgroups are specifically distinct. The subgroups are not correlated with the variation of the colour pattern. Instead, each population has some own trends in altering the basic colour pattern. It is therefore not appropriate to rank the subgroups as subspecies.



FIG. 4

Supposed glacial refugia and ways of postglacial colonization of *Glomeris transalpina* (see text for explanation).

The geographically restricted alleles suggest that there must have been at least two glacial refugia for *G. transalpina* from where colonization of the presently inhabited localities has started (Fig. 4). The eastern subgroup with Albula, Glurns and Lago di Poschiavo probably had a refuge in the mountains north of Bergamo and/or Brescia. Lago di Poschiavo may have been colonized from the Bergamo refuge through the Adda Valley, while Glurns was colonized from the Brescia refuge. The origin of the Albula population is not clear, the allozyme data are not conclusive in this case. All western populations may originate from the nunataks in Ticino. The Valais most probably was colonized only once over the Nufenen, and the Bernese Alps independently from that over the Nufenen and the Grimsel. The alleles that are restricted to Valais and Ticino do not favour a separate colonization of the Simplon from the south. Loucherhorn was a Nunatak and might have been inhabited by *G. transalpina* during the Pleistocene. The allozyme data, however, show that this population is very close to the Valais and Ticino populations which suggests that Loucherhorn was colonized from the south.

Taking into consideration its present distribution, we assume that *G. oblongoguttata* had its glacial refuge on both sides of the Oglio Glacier like the eastern populations of *G. transalpina*. This, of course, requires genetic isolation during the Pleistocene. We, therefore, conclude that specific separation of *G. oblongoguttata* and *G. transalpina* occurred before the Pleistocene (> 1.6 mio years BP).

At present, both species inhabit woods of the mountainous, subalpine and the adjacent levels. *G. transalpina* prefers higher regions compared to *G. oblongoguttata*. Thus, especially in the pre-alps, colonization would not be confined to the valleys. This renders the interpretation of postglacial colonization more difficult, but shows that mountain chains are not necessarily a barrier for dispersal. The limited present ranges of both species, as compared to e.g. the widespread *G. marginata*, may be due to the crooked topography of the Alps. The scarcity of records of *G. transalpina* in the Northern Alps also supports the hypothesis of southern refugia and a northward expansion.

#### ACKNOWLEDGEMENTS

M. E. Braunwalder, B. Gantenbein, P. Marmet and P. Sonderegger helped us gather the glomerids used in this study. L. Beer, L. Frauchiger and V. Siegfried assisted in the laboratory work. H. Baur gave nomenclatorial advice.

#### REFERENCES

- ATTEMS, C. 1927. Myriopoden aus dem nördlichen und östlichen Spanien, gesammelt von Dr. F. Haas in den Jahren 1914-1919. - Nebst Beiträgen zur Kenntnis der Lithobiiden, Glomeriden, sowie der Gattungen *Brachydesmus* und *Archiulus*. *Abhandlungen der Senckenbergischen Naturforschenden Gesellschaft* 39(3): 235-289.
- FODDAL, D., MINELLI, A., SCHELLER, U. & ZAPPAROLI, M. 1995. Chilopoda, Diplopoda, Pauropoda, Symphyla. In: MINELLI, A., RUFFO, S. & LA POSTA, S. (eds). Checklist delle specie della fauna italiana 32: 1-35. *Calderini, Bologna*.
- GORMAN, G. C. & RENZI, J. jr. 1979. Genetic distance and heterozygosity estimates in electrophoretic studies: effects of sample size. *Copeia* 1979 (2): 242-249.
- HAAKER, U. 1969. Spermaübertragung von *Glomeris* (Diplopoda). *Naturwissenschaften* 56: 467.
- HOESS, R. & SCHOLL, A. 1999. *Glomeris undulata* Koch and *G. conspersa* Koch are conspecific. - Enzyme electrophoretic evidence and taxonomical consequences (Diplopoda: Glomeridae). *Revue suisse de Zoologie* 106(3): 643-661.
- HOESS, R., SCHOLL, A. & LÖRTSCHER, M. 1997. The *Glomeris*-taxa *hexasticha* Brandt and *intermedia* Latzel: species or subspecies? — allozyme data (Diplopoda, Glomerida, Glomeridae). *Entomologica Scandinavica, Supplement* 51: 133-138.
- KOCH, C. L. 1836. Deutschlands Crustaceen, Myriapoden und Arachniden. In: Deutschlands Insecten ... fortgesetzt von G. A. W. HERRICH-SCHÄFFER, Heft 4 (= G. W. F. PANZER, Faunae Insectorum Germanicae initia, Heft 137). *Pustet, Regensburg*.
- KOCH, C. L. 1844. Deutschlands Crustaceen, Myriapoden und Arachniden. In: Deutschlands Insecten ... fortgesetzt von G. A. W. HERRICH-SCHÄFFER, Heft 40 (= G. W. F. PANZER, Fauna Insectorum Germanicae initia, Heft 190). *Pustet, Regensburg*.
- KOCH, C. L. 1847. System der Myriapoden, mit den Verzeichnissen und Berichtigungen zu Deutschlands Crustaceen, Myriapoden und Arachniden Heft 1-40. *Pustet, Regensburg*, V + 272 pp.
- KOCH, C. L. 1863. Die Myriapoden. Getreu nach der Natur abgebildet und beschrieben. I. + II. *Schmidt, Halle*, 134 + 112 pp.
- LATZEL, R. 1884. Die Myriopoden der österreichisch-ungarischen Monarchie. Mit Bestimmungstabellen aller bisher aufgestellten Myriopoden-Gattungen und zahlreichen, die morphologischen Verhältnisse dieser Thiere illustrierenden Abbildungen. Zweite Hälfte: Die Symphylen, Pauropoden und Diplopoden, nebst Bemerkungen über exotische und fossile

- Myriopoden-Genera und einem Verzeichnis der gesammten Myriopoden-Literatur. *Hölder, Wien*, 414 pp.
- MAYR, E. & ASHLOCK, P. D. 1991. Principles of systematic zoology - 2nd edition. *Mc Graw Hill, New York*, XX + 475 pp.
- NEI, M. 1978. Estimation of average heterozygosity and genetic distance for a small number of individuals. *Genetics* 89: 583-590.
- SCHOLL, A., CORZILLIUS, B. & VILLWOCK, W. 1978. Beitrag zur Verwandtschaftsanalyse altweltlicher Zahnkarpfen der Tribus Aphaniini (Pisces, Cyprinodontidae) mit Hilfe elektrophoretischer Untersuchungsmethoden. *Zeitschrift für zoologische Systematik und Evolutionsforschung* 16: 116-132.
- SCHUBART, O. 1934. Tausendfüßler oder Myriapoda - I: Diplopoda. In: DAHL, F. (ed.). Die Tierwelt Deutschlands und der angrenzenden Meeresteile nach ihren Merkmalen und nach ihrer Lebensweise, *Fischer, Jena*, 28. Teil, VII + 318 pp.
- STRASSER, C. & MINELLI, A. 1984. Elenco dei diplopodi d'Italia. *Lavori Societa veneziane Science naturale* 9(2): 193-212.
- SWOFFORD, D. L. & SELANDER, R. B. 1989. BIOSYS-1. A computer program for the analysis of allelic variation in population genetics and biochemical systematics. Release 1.7., *D. L. Swofford, Illinois Natural History Survey*.
- VERHOEFF, C. 1894. Beiträge zur Diplopoden-Fauna Tirols. *Verhandlungen der zoologisch-botanischen Gesellschaft in Wien* 44: 9-34.
- VERHOEFF, K. W. 1902. Ueber Diplopoden. 1. Aufsatz: Formen aus Tirol, Italien und Cypem. *Archiv für Naturgeschichte* 68(1): 175-198.
- VERHOEFF, K. W. 1906. Über Diplopoden. 4. (24.) Aufsatz: Zur Kenntnis der Glomeriden (zugleich Vorläufer einer *Glomeris*-Monographie). (Beiträge zur Systematik, Geographie, Entwicklung, vergleichenden Morphologie und Biologie. *Archiv für Naturgeschichte* 72(1): 107-226.
- VERHOEFF, K. W. 1911. Ueber Diplopoden. 20. (40.) Aufsatz: Neuer Beitrag zur Kenntnis der Gattung *Glomeris*. *Jahreshefte des Vereins für vaterländische Naturkunde in Württemberg* 67: 78-147.
- VERHOEFF, K. W. 1929. Zur Systematik, vergleichenden Morphologie und Geographie europäischer Diplopoden, zugleich ein zoogeographischer Beitrag. 111. Diplopoden-Aufsatz. *Zoologisches Jahrbuch für Systematik* 57: 555-656.
- VERHOEFF, K. W. 1930. Zur Geographie, Ökologie und Systematik südalpenländischer Chilognathen. (116. Diplopoden-Aufsatz). *Zeitschrift für Morphologie und Ökologie der Tiere* 18: 576-668.
- VERHOEFF, K. W. 1931. Chilognathen aus den Bergamasker Alpen und Nachbargebieten; auch über zwei neue Gattungen der Polydesmoidea aus Spanien und Japan. (121. Diplopoden-Aufsatz). *Zoologisches Jahrbuch für Systematik* 61: 397-452.
- VERHOEFF, K. W. 1932. Zur Geographie, Ökologie und Systematik der Diplopoden Nordwestitaliens. *Archiv für Naturgeschichte* N.F. 1(4): 517-645.
- VERHOEFF, K. W. 1936a. Chilognathen aus Nordwestitalien und über einige andere mediterrane Diplopoden (128. Diplopoden-Aufsatz). *Zoologisches Jahrbuch für Systematik* 68: 353-444.
- VERHOEFF, K. W. 1936b. Zur Systematik, Geographie und Ökologie der Diplopoden von Oberwallis und Insubrien. (132. Diplopoden-Aufsatz). *Zoologisches Jahrbuch für Systematik* 68: 205-272.
- VERHOEFF, K. W. 1937. Studien in Nordwestitalien 1929-1933. 129. Diplopodenaufsatz. *Zoologisches Jahrbuch für Systematik* 70: 87-169.

## Redescription of *Electrogena galileae* (Demoulin, 1973) (Ephemeroptera, Heptageniidae)

Carlo BELFIORE<sup>1</sup> and Michel SARTORI<sup>2</sup>

<sup>1</sup> Dipartimento di Zoologia, Università di Napoli Federico II, via Mezzocannone 8, I-80134 Napoli.

<sup>2</sup> Musée de Zoologie, Palais de Rumine, Case postale 448, CH-1000 Lausanne 17.

**Redescription of *Electrogena galileae* (Demoulin, 1973) (Ephemeroptera, Heptageniidae).** - Male imagines and larvae of *Electrogena galileae* (Demoulin, 1973), from Israel and Lebanon, are redescribed using the standard diagnostic characters, both quantitative and qualitative, recently proposed for the species of the genus *Electrogena*. Three new larval characters (one meristic and two multistate ones), useful for the taxonomy of *E. galileae*, are added to the former set. *E. galileae* proved to be distinctly separated from the other species described by the standard set.

**Key-words:** Ephemeroptera - Heptageniidae - *Electrogena galileae* - redescription - taxonomy - Lebanon - Israel.

### INTRODUCTION

A lot of *Electrogena* species were described from Near and Middle East (BRAASCH 1978, 1980a, b, 1981, 1983a, b; KAZANCI 1986, 1987, 1990; KAZANCI & BRAASCH 1986) and many other entities belonging to this genus are possibly still unknown. As pointed out by SARTORI (1992), most of the species from those areas were only partially and summarily described. Therefore any attempt of identification is still very difficult. Recently several diagnostic characters for the separation of *Electrogena* species were proposed (BELFIORE 1994, 1995, 1996, 1997; BELFIORE & DESIO 1995; BELFIORE *et al.* 1997; MALZACHER 1996), which proved to be very useful for the identification and discrimination of most European species. Male imagines can be identified mainly by the markings on abdomen, some characteristics of genitalia (i.e. shape of penis lobes and titillators, denticulation of outer sclerites (MALZACHER 1996)), wing and body colouration. Diagnostic characters for female imagines are abdominal markings, wing colouration, shape of the subgenital plate and morphology of eggs. Many more characters are available for the identification of larvae: a set of sixteen diagnostic features, both quantitative and qualitative, was proposed by BELFIORE (1994). Redescriptions of species using these new taxonomic tools is a necessary step for checking the validity of *Electrogena* species and understanding the relationships among them. This would be particularly useful for those areas, like Near and Middle East where the diversification of the genus seems very high.

In this paper we begin the revision of the Middle Eastern species with a redescription of *Electrogena galileae*, formerly described by DEMOULIN (1973) and SARTORI (1992).

## REDESCRIPTION

### ***Electrogena galileae*** (Demoulin, 1973)

*Ecdyonurus golanicus* Samocha, 1972, nomen nudum

*Ecdyonurus galileae* Demoulin, 1973

*Ecdyonurus galileae*: DIA 1983; MOUBAYED 1986; KOCH 1988

*Electrogena galileae*: SARTORI 1992

*Material*. ISRAEL (Museum of Zoology, Lausanne; Michel Sartori leg. et det.): Hula Valley, Nahal Dan, Tel Dan, 170 m, 8.V.1990, 1 male imago (reared) with nymphal skin, 3 larvae; Hula Valley, Nahal Dan, 180 m, 7.V.1990, 3 larvae; Hula Valley, Enot Layish (Tel Springs), 200m, 12.V.1990, 5 larvae. LEBANON (C. Belfiore Collection; A. Dia leg.): Aouali River, 710m, 4.VII.1980: 1 male imago; Nabaa Mourched, 800 m, 13.VI.1981, 2 male imagines; Santa Yahfoufah, 8.IV.1985, 1 male imago.

### MALE IMAGO (in alcohol)

Body 9.5 mm; cerci: 23 mm. Eyes grey, ventral margin bordered with a dark grey band. Thoracic tergites and sternites light brown, pleurae pale yellowish. Fore legs light brown: femora with a wide dark band in the middle and a smaller one near the junction with the tibia; the last two segments of tarsi are lighter. Mid and hind legs yellowish with the same markings as fore legs; tarsi slightly darker. Wings uniformly tinged with yellowish brown; veins light brown, cross veins darker, bordered with brownish violet in the fore part of fore wing. First costal cross vein bold, coloured with violet brownish. Abdomen yellowish, with violet brown markings (Fig. 1). Cerci greyish brown, slightly darker at joints. Genitalia (Figs 2-3): styliger yellowish, hind margin with two flat and widely rounded projections. Gonopodes greyish, last segment lighter. Penis stem very short. Penis lobes asymmetrical, outer edge rounded, inner edge straight. 2-4 small denticles on outer sclerite, near basis of lobes.

### LARVA (in alcohol)

Body length (full-grown larvae): 8 mm (male); 8.5 mm (female). Cerci: 14-15 mm.

General aspect and colouration. Larvae of *E. galileae* are small with long and slender legs. General colouration is brown with lighter markings. Two light rounded spots are at sides of median line, near the fore margin of head (Fig. 4). Imaginal markings are visible also in half grown larvae.

Diagnostic characters (number of specimens examined=11). The set of larval diagnostic characters is fully explained and figured in BELFIORE (1996, 1997).

### A. *Quantitative characters*

Mean, range and variance are reported. *E. galileae* is compared with the *Electrogena* species previously examined by the standard set of diagnostic characters:

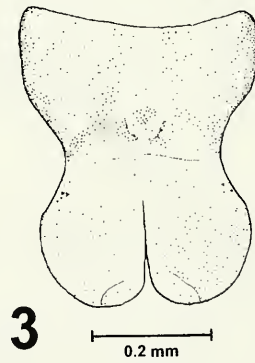
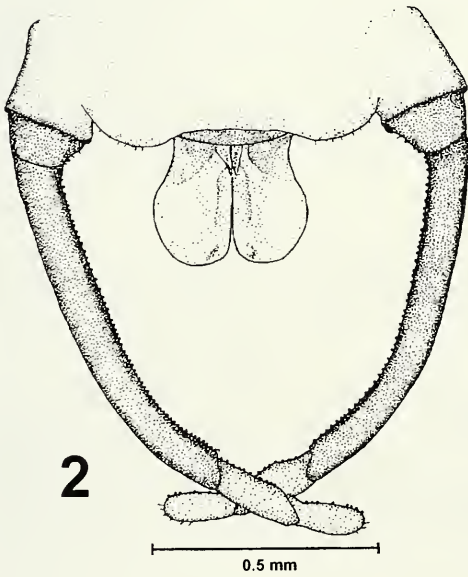
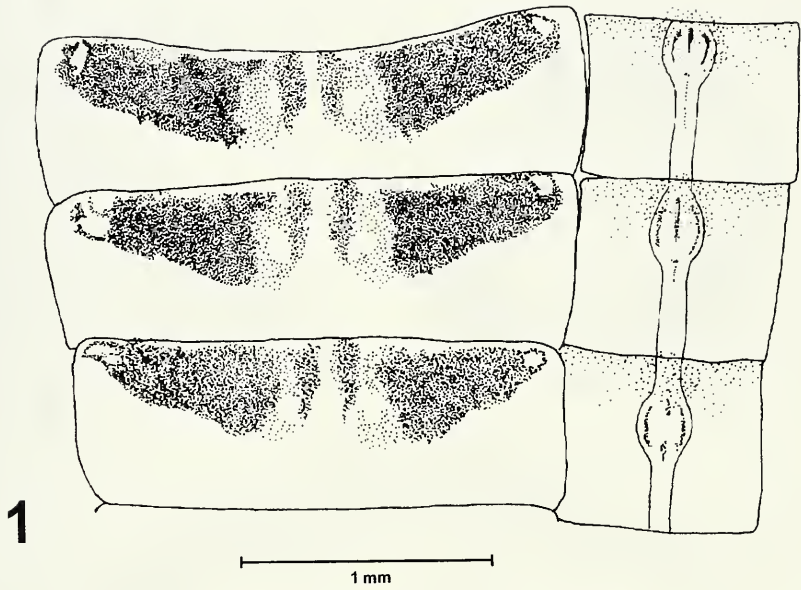

FIGS 1-3

*Electrogena galileae*, male imago: III-V tergites and sternites (from a slide) (1); genitalia from ventral view (2); penis from dorsal view (3).

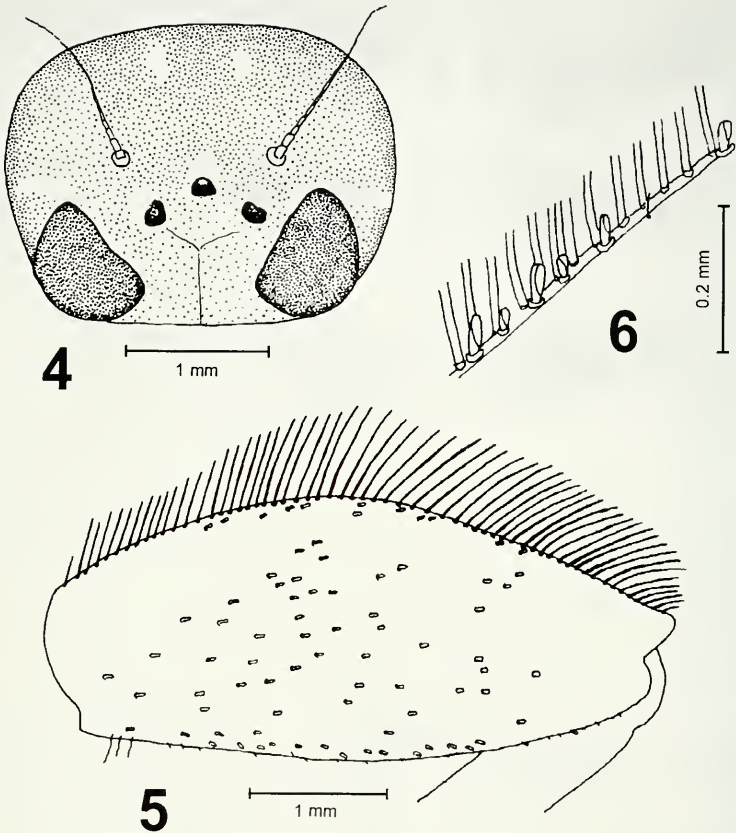

FIGS 4-6

*Electrogena galileae*, larva: head (4); fore femur from dorsal view (5); magnification of hind side of femur (long bristles are truncated).

*E. calabra* Belfiore, 1995; *E. fallax* (Hagen, 1864); *E. grandiae* (Belfiore, 1981); *E. gridellii* (Grandi, 1953), *E. hyblaea* Belfiore, 1994; *E. lateralis* (Curtis, 1834); *E. malickyi* (Braasch, 1983); *E. ujhelyii* (Sowa, 1981), *E. zebrata* (Hagen, 1864) (BELFIORE 1996) and *E. lunaris* Belfiore & Scillitani, 1997 (BELFIORE *et al.* 1997). Phenetic affinities between species are discussed by comparison of mean values and ranges.

a) *Meristic characters*:

1. N\_PLP : 11.09; 7-19; 10.9909. The number of hairs on fore side of first segment of maxillary palpus is moderately low. Hairs are often distributed in two groups, near basis and at apex of segment (Fig. 15). Closest species are *E. calabra* (mean: 9.97) and *E. zebrata* (12.52). Range overlaps with all other species.



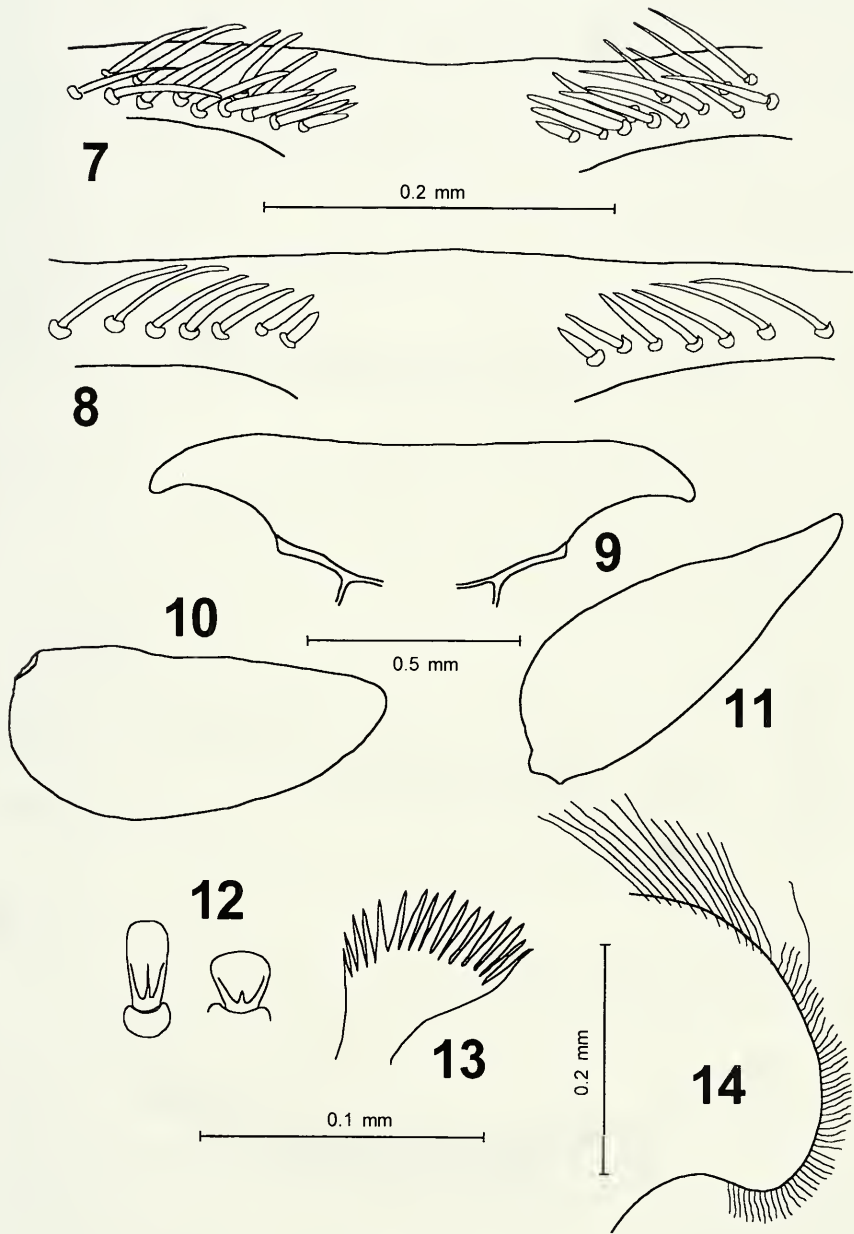

FIGS 7-14

*Electrogena galileae*, larva: bristles on the ventral surface of labrum (7); labrum (9); 1st gill plate (10); 7th gill (11); bristles on upper surface of fore femur (12); 5th comb shaped bristle of galea-lacinia (13); apex of hypopharynx lobe (14). *E. ujhelyii*, larva: bristles on the ventral surface of labrum (8).

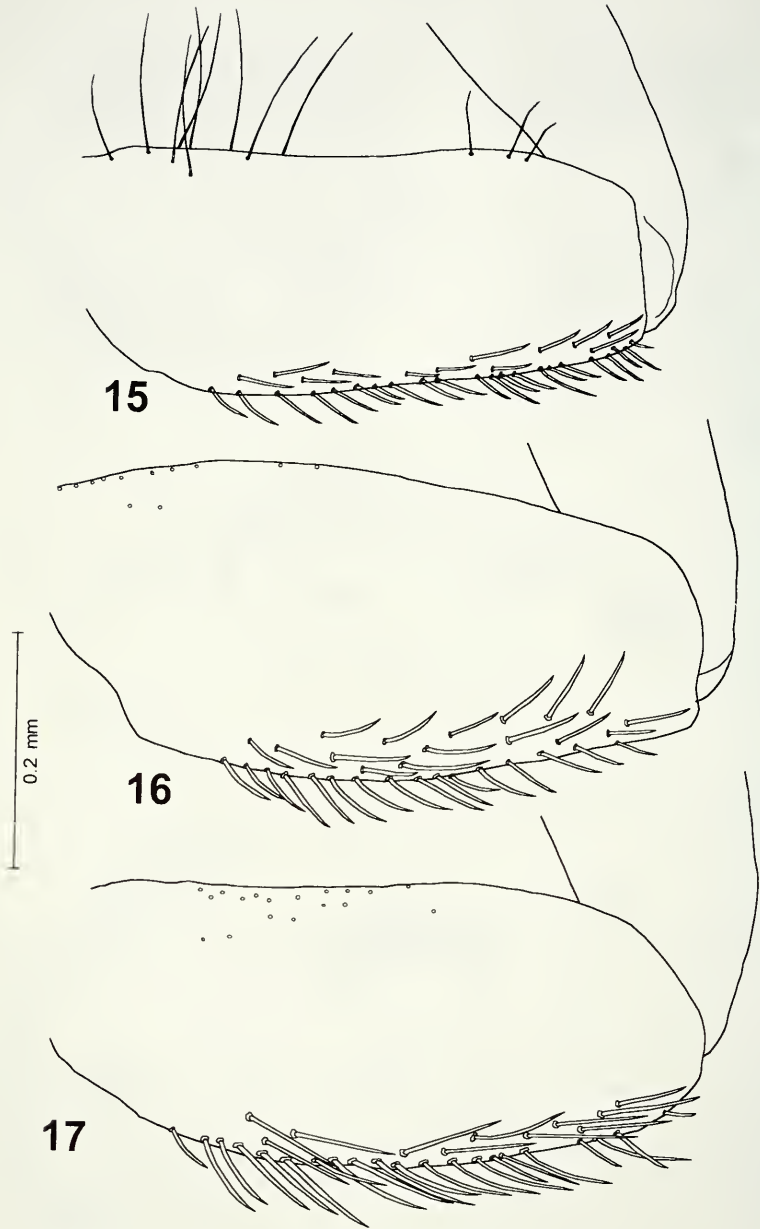

FIGS 15-17

First segment of maxillary palpus of larvae: *Electrogena galileae* (15); *E. zebrata* (16); *E. gridellii* (17). In (16) and (17) the long hairs on fore margin are not figured.

2. N\_OUT: 0; 0; 0; 0. The only species with no hairs on outer margin of galea-lacinia and zero variance are *E. malickii* and *E. zebrata*. Species with such hairs always present are *E. calabra*, *E. fallax*, *E. gridellii* and *E. ujhelyii*.
3. N\_CBS: 19.77; 19-21.5; 0.7182. The number of comb-shaped bristles on the fore margin of galea-lacinia is moderately high. Closest species are *E. calabra* (19.12) and *E. ujhelyii* (20.38). Range is overlapping with all species.
4. N\_TCB (Fig. 13): 14.55; 13-16; 0.7227. The number of teeth on the 5th comb-shaped bristle (fore margin of galea-lacinia) is the highest among species considered. The closest species is *E. malickyi* (13.98). Non-overlapping are *E. grandiae* (6.5-11.5) and *E. lunaris* (5-7).
5. N\_CLW: 2.36; 2-4; 0.4545. The number of teeth on the tarsal claw is generally two, with the exception of only one specimen which has 3 to 5 (modal value=4). Closest species is *E. ujhelyii* (2.52), which share the same range and the unusually high variance. The only non-overlapping species are those with an invariant single tooth (*E. lateralis* and *E. lunaris*).
6. N\_BVF: 22.45; 6-36; 90.8727. The number of bristles on the ventral side of femora, near the hind margin, shows an unusual wide range. However *E. galileae* can be considered belonging to the group with «many» such bristles (*E. ujhelyii* (27.90), *E. zebrata* (36.65), *E. fallax* (41.59)). The maximum number of bristles shared by all other species is 3. A very distinctive feature of *E. galileae* is the shape of these bristles (Fig. 6), blunt or rounded at apex (pointed in other species).

One more meristic character proved to be relevant to taxonomy of *E. galileae*. It can be added to the standard set:

7. N\_HFF: Number of setae (long and tiny hairs) on the fore (ventral) margin of fore femur. Hairs counted are those at least 1.5 times long as bristles along the fore margin of femora. *E. galileae* has generally three long hairs near basis of the femora (Fig. 5). None of the other species share this character.

*b) Ratio characters:*

8. R\_1GI (1st gill length/width): 2.116; 1.798-2.411; 0.0284. First gill is moderately short, intermediate between *E. lateralis* (2.137) and *E. zebrata* (1.992). Range is overlapping with all species. The shape of the first gill (Fig. 10) is relatively constant among individuals.
9. R\_7GI (7th gill length/width): 2.613; 2.304-2.807; 0.0247. Seventh gill is moderately long (Fig. 11), intermediate between *E. grandiae* (2.627) and *E. malickyi* (2.423). It cannot be separated from other species by range.
10. R\_LBR (total width of labrum/width of lateral projections): 4.157; 3.835-4.511; 0.0352. Labrum is very slender. R\_LBR is the lowest among species considered. Closest species is *E. malickyi* (4.331). The only non-overlapping species is *E. lunaris* (4.786-6.744). The shape of labrum is very peculiar (Fig. 9): it recalls the shape of labrum in the *Ecdyonurus* species. The tips of lateral projections are often bent backwards.

11. R\_GLA (outer distance/inner distance between glossae): 3.213; 2.958-3.778; 0.0710. Glossae are relatively close each other. Closest species are *E. lateralis* (3.174) and *E. hyblaea* (3.237). This character and the next one are the less discriminating among the *Electrogena* species.
12. R\_GLB (outer distance between glossae/mean width of glossae): 2.812; 2.537-3.056; 0.0463. Glossae are moderately wide. Closest species are *E. fallax* (2.777) and *E. ujhelyii* (2.837).

#### *B. Shape and multistate characters*

13. S\_HLB - the apex of lateral lobes of hypopharynx is covered with short hairs, about 1/4 long as hairs along the fore margin (Fig. 14). This character state is intermediate between species with very short hairs (1/8 of fore hairs: *E. lateralis*, *E. lunaris*, *E. ujhelyii*) and species with long hairs all around the apex (all other species).
14. S\_PGL - paraglossae are narrow, somewhat pointed.
15. S\_PNT - hind corners of pronotum are smoothly rounded.
16. S\_BFE - distal bristles on upper surface of fore femora are short and rounded, with diverging sides (Fig. 12).
17. S\_TAR - tarsi are darkened at apex only.
18. S\_7GI - 7th gill is gradually narrowing at apex.

Two more characters are relevant to taxonomy of *E. galileae* and are to be added to the previous list. Even if they could be considered quantitatively, two discrete character states can be recorded throughout the species here considered. We provisionally treat them as multistate characters.

19. S\_PLB: length of bristles on hind margin of the first segment of maxillary palpus. These bristles are very short in *E. galileae* (1/4 to 1/5 as width of segment) (Fig. 15). The other species have longer bristles (at least 1/3 as width of segment) (Fig. 17) with the exception of *E. zebrata* (about 1/4) (Fig. 16).
20. S\_LBB: arrangement of paramedian bristles on ventral side of labrum, near the fore margin (a character used for the discrimination of *helveticus* and *venosus* group within the genus *Ecdyonurus* (BELFIORE & BUFFAGNI 1994). In *E. galileae* these bristles are arranged in two irregular rows (Fig. 7), unlike other *Electrogena* species, which share slender bristles arranged in a single row (Fig. 8).

#### DIAGNOSIS

*E. galileae* definitely appears phenetically far from the other considered species. It could be more usefully compared with other *Electrogena* species from the same area, when complete redescriptions of them will be available. At this moment the larval diagnosis is very easy because of some unique features: labrum with lateral projections often bent backwards; bristles on ventral surface of labrum (S\_LBB) arranged in two rows; some long hairs at basis of fore margin of femora (N\_HFF); apex of lobes of hypopharynx with hairs 1/4 as long as hairs along the fore margin of lobes (S\_HLB).

Useful characters for identification are also the following: labrum very slender (R\_LBR low); very short bristles on the hind side of the first segment of maxillary palpus (S\_PLB), lack of hairs on outer margin of galea-lacinia (N\_OUT), a very high number of teeth on the 5th comb-shaped bristle (N\_TCB). Male imagines can be identified by markings of abdomen, colouration of wings, pigmentation of wing veins and shape of penis stem and penis lobes.

## ACKNOWLEDGMENTS

We are indebted to Prof. A. Thomas (Toulouse) for the kind gift of specimens from Lebanon.

## LITERATURE

- BELFIORE, C. 1994. Taxonomic Characters for Species Identification in the Genus *Electrogena* Zurwerra & Tomka, with a Description of *Electrogena hyblaea* sp. n. from Sicily (Ephemeroptera, Heptageniidae). *Aquatic Insects* 16(4): 193-199.
- BELFIORE, C. 1995. Description of *Electrogena calabra* n. sp., a new species from Southern Italy (Ephemeroptera, Heptageniidae). *Annales de Limnologie* 31(1): 29-34.
- BELFIORE, C. 1996. Identification and discrimination of *Electrogena* species by numerical methods (Ephemeroptera, Heptageniidae). *Systematic Entomology* 21: 1-13.
- BELFIORE, C. 1997. Taxonomic characters and discrimination of species in the genus *Electrogena* Zurwerra & Tomka (Ephemeroptera, Heptageniidae), pp. 427-433. In: LANDOLT, P. & SARTORI, M. (eds). Ephemeroptera & Plecoptera: Biology, Ecology, Systematics. *MTL Fribourg*, XI+569 pp.
- BELFIORE, C. & BUFFAGNI, A. 1994. Revision of the Italian species of *Ecdyonurus helveticus* group: taxonomy of nymphs (Ephemeroptera, Heptageniidae). *Bulletin de la Société entomologique suisse* 67: 143-149.
- BELFIORE, C. & DESIO, F. 1995. Taxonomy and distribution of *Electrogena ujhelyii* (Sowa, 1981) (Insecta: Ephemeroptera: Heptageniidae). *Annalen des Naturhistorisches Museum in Wien* 97 B: 151-154.
- BELFIORE, C., SCILLITANI, G., PICARIELLO, O. & CATAUDO, A. 1997. Morphological and electrophoretic evidence for a new species of *Electrogena* from Central Italy: description of *E. lunaris* sp. n. *Aquatic Insects* 19(3): 129-140.
- BRAASCH, D. 1978. Neue *Ecdyonurus*-Arten (Ephemeroptera, Heptageniidae) aus dem Kaukasus und aus Transkaukasien (Sowjetunion). I. *Entomologische Nachrichten* 22(10): 145-160.
- BRAASCH, D. 1980a. Neue *Ecdyonurus*-Arten (Heptageniidae, Ephemeroptera) aus dem Kaukasus und Transkaukasien (Sowjetunion). II. *Entomologische Nachrichten* 23(2): 23-28.
- BRAASCH, D. 1980b. Neue *Ecdyonurus*-Arten (Heptageniidae, Ephemeroptera) aus dem Kaukasus und Transkaukasien (Sowjetunion) (3). *Entomologische Nachrichten* 24(7): 103-110.
- BRAASCH, D. 1981. Eintagsfliegen aus Anatolien und Iran (Insecta, Ephemeroptera). *Faunistische Abhandlungen, Staatliches Museum für Tierkunde Dresden* 8(6): 75-79.
- BRAASCH, D. 1983a. *Ecdyonurus bothmeri* n. sp. aus dem Iran (Ephemeroptera, Heptageniidae). *Entomologische Nachrichten* 27(4): 177.
- BRAASCH, D. 1983b. *Ecdyonurus armeniacus* n. sp. aus der Armenischen SSR (UdSSR). *Reichenbachia* 21: 87-90.
- DEMOULIN, G. 1973. Contribution à l'étude des Ephéméroptères d'Israel. Introduction et I. Heptageniidae. *Bulletin de l'Institut royal des Sciences naturelles de Belgique* 49(8): 1-19.

- DIA, A. 1983. Recherches sur l'écologie et la biogéographie des cours d'eau du Liban méridional. *Thèse Doctorat d'Etat, Marseille*, 302 pp.
- KAZANCI, N. 1986. A new Ephemeroptera (Heptageniidae) species from Anatolia. *Doga Tu Bio*, 10(3): 391-393.
- KAZANCI, N. 1987. *Ecdyonurus necatii*, a new Ephemeroptera (Heptageniidae) species from Turkey. *Aquatic Insects* 9 (1): 17-20.
- KAZANCI, N. 1990. Turkiye Heptageniidae (Insecta: Ephemeroptera) faunasi uzerine arastirmalar.II. Cins *Electrogena* Zurwerra et Tomka, 1985. *Hacettepe Fen. Muhendislik Bilimleri Derg. Ser. A* 11: 169-180.
- KAZANCI, N. & BRAASCH, D. 1986. Zwei neue Heptageniidae (Ephemeroptera) aus Anatolien. *Bulletin de la Société entomologique suisse* 59: 365-368.
- KOCH, S. 1988. Mayflies of the Northern Levant (Insecta: Ephemeroptera). *Zoology of the Middle East* 2: 89-112.
- MALZACHER, P. 1996. Genitalmorphologische Merkmale zur Unterscheidung der in Baden-Württemberg vorkommenden *Electrogena*-Arten (Heptageniidae, Ephemeroptera). *Lauterbornia* 25: 81-93.
- MOUBAYED, Z. 1986. Recherches sur la faunistique, l'écologie et la zoogéographie de trois réseaux hydrographiques du Liban: l'Assi, le Litani et le Beyrouth. *Thèse Doctorat d'Etat, Univ. Toulouse*, 496 pp.
- SAMOCHA, M. 1972. Ephemeroptera of Israel. *Thesis, Tel-Aviv University*, 112 pp.
- SARTORI, M. 1992. Mayflies from Israel (Insecta: Ephemeroptera). I.- Heptageniidae, Ephemereleididae, Leptophlebiidae & Palingeniidae. *Revue suisse de Zoologie* 99(4): 835-858.

REVUE SUISSE DE ZOOLOGIE

Tome 106 — Fascicule 4

	Pages
ZOOLOGIA ET BOTANICA '99, Zurich, 17-19 February 1999 (Joint meeting of the Swiss Society of Zoology and the Swiss Society of Botany). . . . .	745-787
BESUCHET, Claude. Psélaphides paléarctiques nouveaux ou méconnus (Coleoptera: Staphylinidae: Pselaphinae). . . . .	789-811
LEISTIKOW, Andreas. <i>Androdeloscia</i> gen. n., a new genus of South American terrestrial isopods with description of 13 new species (Crustacea: Oniscidea: "Philosciidae"). . . . .	813-904
LIENHARD, Charles & N. Philip ASHMOLE. <i>Sphaeropsocopsis myrtleae</i> sp. n., a blind subterranean psocid from St Helena (Psocoptera: Sphaeropsocidae). . . . .	905-912
ANGELINI, Fernando. New species of <i>Agathidium</i> Panzer from China (Coleoptera, Leiodidae, Agathidiini). . . . .	913-927
LOURENÇO, Wilson R. Considérations taxonomiques sur le genre <i>Hadogenes</i> Kraepelin, 1894: création des Hadogeninae subfam. n. et description d'une espèce nouvelle de l'Angola (Scorpiones, Scorpionidae, Hadogeninae). . . . .	929-938
CASSOLA, Fabio. Studies on tiger beetles. XCVIII. A new <i>Cylindera</i> from Chubut, Argentina (Coleoptera: Cicindelidae). . . . .	939-943
SCHWENDINGER, Peter J. & Jochen MARTENS. A taxonomic revision of the family Oncopodidae II. The genus <i>Gnomulus</i> Thorell (Opiliones, Laniatores). . . . .	945-982
ZICSI, András & Csaba CSUZDI. Weitere Angaben zur Regenwurmfauna Frankreichs mit Beschreibung fünf neuer Arten (Oligochaeta: Lumbricidae). . . . .	983-1003
CARPANETO, Giuseppe M. & Roberto MIGNANI. A review of the Himalayan <i>Thorectes</i> (Coleoptera: Geotrupidae), with description of a new species from northern India. . . . .	1005-1012
HOESS, René & Adolf SCHOLL. The identity of <i>Glomeris quadrifasciata</i> C. L. Koch (Diplopoda: Glomeridae). . . . .	1013-1024
BELFIORE, Carlo & Michel SARTORI. Redescription of <i>Electrogena galileae</i> (Demoulin, 1973) (Ephemeroptera, Heptageniidae). . . . .	1025-1034

REVUE SUISSE DE ZOOLOGIE

Volume 106 — Number 4

	Pages
ZOOLOGIA ET BOTANICA '99, Zurich, 17-19 February 1999 (Joint meeting of the Swiss Society of Zoology and the Swiss Society of Botany). . . . .	745
BESUCHET, Claude. New or poorly known Palaearctic pselaphids (Coleoptera: Staphylinidae: Pselaphinae). . . . .	789
LEISTIKOW, Andreas. <i>Androdeloscia</i> gen. n., a new genus of South American terrestrial isopods with description of 13 new species (Crustacea: Oniscidea: "Philosciidae"). . . . .	813
LIENHARD, Charles & N. Philip ASHMOLE. <i>Sphaeropsocopsis myrtleae</i> sp. n., a blind subterranean psocid from St Helena (Psocoptera: Sphaeropsocidae). . . . .	905
ANGELINI, Fernando. New species of <i>Agathidium</i> Panzer from China (Coleoptera, Leiodidae, Agathidiini). . . . .	913
LOURENÇO, Wilson R. Taxonomic considerations on the genus <i>Hadogeues</i> Kraepelin, 1894: proposition of the Hadogeninae subfam. n., and description of a new species from Angola (Scorpiones, Scorpionidae, Hadogeninae). . . . .	929
CASSOLA, Fabio. Studies on tiger beetles. XCVIII. A new <i>Cylindera</i> from Chubut, Argentina (Coleoptera: Cicindelidae). . . . .	939
SCHWENDINGER, Peter J. & Jochen MARTENS. A taxonomic revision of the family Oncopodidae II. The genus <i>Guonulus</i> Thorell (Opiliones, Laniatores). . . . .	945
ZICSI, András & Csaba CSUZDI. Further Contribution to the earthworm fauna (Oligoschaeta: Lumbricidae) of France, with description of five new species and one subspecies. . . . .	983
CARPANETO, Giuseppe M. & Roberto MIGNANI. A review of the Himalayan <i>Thorectes</i> (Coleoptera: Geotrupidae), with description of a new species from northern India. . . . .	1005
HOESS, René & Adolf SCHOLL. The identity of <i>Glomeris quadrifasciata</i> C. L. Koch (Diplopoda: Glomeridae). . . . .	1013
BELFIORE, Carlo & Michel SARTORI. Redescription of <i>Electrogena galileae</i> (Demoulin, 1973) (Ephemeroptera, Heptageniidae). . . . .	1025

**Indexed in** CURRENT CONTENTS, SCIENCE CITATION INDEX



PUBLICATIONS DU MUSÉUM D'HISTOIRE NATURELLE DE GENÈVE

CATALOGUE DES INVERTÉBRÉS DE LA SUISSE, N <sup>os</sup> 1-17 (1908-1926) . . . . .	série	Fr. 285.—
(prix des fascicules sur demande)		
REVUE DE PALÉO BIOLOGIE . . . . .	Echange ou par fascicule	Fr. 35.—
LE RHINOLOPHE (Bulletin du centre d'étude des chauves-souris) . . . . .	par fascicule	Fr. 35.—
COLLEMBOLFAUNA EUROPAS von H. GISIN, 312 Seiten, 554 Abbildungen, 1960 (Nachdruck, 1984) . . . . .		Fr. 30.—
THE EUROPEAN PROTURA THEIR TAXONOMY, ECOLOGY AND DISTRIBUTION WITH KEYS FOR DETERMINATION by J. NOSEK, 346 pages, 111 figures in text, 1973 . . . . .		Fr. 30.—
CLASSIFICATION OF THE DIPLOPODA par Richard L. HOFFMAN, 237 pages, 1979 . . . . .		Fr. 30.—
LES OISEAUX NICHEURS DU CANTON DE GENÈVE par P. GÉROUDET, C. GUÉX et M. MAIRE 351 pages, nombreuses cartes et figures, 1983 . . . . .		Fr. 45.—
CATALOGUE COMMENTÉ DES TYPES D'ECHINODERMES ACTUELS CONSERVÉS DANS LES COLLECTIONS NATIONALES SUISSES, SUIVI D'UNE NOTICE SUR LA CONTRIBUTION DE LOUIS AGASSIZ À LA CONNAISSANCE DES ECHINODERMES ACTUELS par Michel JANGOUX, 67 pages, 11 planches, 1985 . . . . .		Fr. 15.—
RADULAS DE GASTÉROPODES LITTORAUX DE LA MANCHE (COTENTIN-BAIE DE SEINE, FRANCE) par Y. FINET, J. WÜEST et K. MAREDA, 62 pages, 1991 . . . . .		Fr. 10.—
GASTROPODS OF THE CHANNEL AND ATLANTIC OCEAN; SHELLS AND RADULAS by Y. FINET, J. WÜEST and K. MAREDA, 1992 . . . . .		Fr. 30.—
O. SCHMIDT SPONGE CATALOGUE par R. DESQUEYROUX-FAUNDEZ & S.M. STONE, 190 pages, 49 plates, 1992 . . . . .		Fr. 40.—
ATLAS DE RÉPARTITION DES AMPHIBIENS ET REPTILES DU CANTON DE GENÈVE par A. KELLER, V. AELLEN et V. MAHNERT, 48 pages, 1993 . . . . .		Fr. 15.—
THE MARINE MOLLUSKS OF THE GALAPAGOS ISLANDS: A DOCUMENTED FAUNAL LIST par Yves FINET, 180 pages, 1995 . . . . .		Fr. 30.—
NOTICE SUR LES COLLECTIONS MALACOLOGIQUES DU MUSEUM D'HISTOIRE NATURELLE DE GENÈVE par Jean-Claude CAILLIEZ, 49 pages, 1995 . . . . .		Fr. 22.—
PROCEEDINGS OF THE XIIIth INTERNATIONAL CONGRESS OF ARACHNOLOGY, Geneva 1995 (ed. Volker MAHNERT), 720 pages, 1996 . . . . .		Fr. 160.—
CATALOGUE OF THE SCAPHIDIINAE (COLEOPTERA: STAPHYLINIDAE) (Instrumenta Biodiversitatis I) par Ivan LÖBL, 192 pages, 1997 . . . . .		Fr. 50.—
CATALOGUE SYNONYMIQUE ET GÉOGRAPHIQUE DES SYRPHIDAE (DIPTERA) DE LA RÉGION AFROTROPICALE (Instrumenta Biodiversitatis II) par Henri G. DIRICKX, 188 pages, 1998 . . . . .		Fr. 50.—
A REVISION OF THE CORYLOPHIDAE (COLEOPTERA) OF THE WEST PALAEARCTIC REGION (Instrumenta Biodiversitatis III) par Stanley BOWESTEAD, 204 pages, 1999 . . . . .		Fr. 60.—



## *Revue suisse de Zoologie: Instructions to Authors*

The *Revue suisse de Zoologie* publishes papers by members of the Swiss Zoological Society and scientific results based on the collections of the Muséum d'histoire naturelle, Geneva. Submission of a manuscript implies that it has been approved by all named authors, that it reports their unpublished work and that it is not being considered for publication elsewhere. A financial contribution may be asked from the authors for the impression of colour plates and large manuscripts. All papers are refereed by expert(s).

In order to facilitate publication and avoid delays authors should follow the *Instructions to Authors* and refer to a current number of R.S.Z. for acceptable style and format. Manuscripts not conforming with these directives are liable to be returned to the authors. Papers may be written in French, German, Italian and English. Authors should aim to communicate ideas and information clearly and concisely in language suitable for the moderate specialist. Authors not writing in their native language should pay particular attention to the linguistic quality of the text.

Manuscripts must be typed, on one side only and double-spaced, on A4 (210 x 297 mm) or equivalent paper and all pages should be numbered. All margins must be at least 25 mm wide. Authors must submit one original and two copies, including tables and figures, in final fully corrected form, and are expected to retain another copy.

Papers should conform to the following general layout:

**Title page.** A concise but informative full title plus a running title of not more than 40 letters and spaces, name(s) in full and surname(s) of author(s), and full address(es).

**Abstract.** The abstract is in English, composed of the title and a short text of up to 200 words. It should summarise the contents and conclusions of the paper. The abstract is followed by less than 10 key-words, separated by hyphens, which are suitable for indexing.

**Introduction.** A short introduction to the background and the reasons for the work.

**Materials and methods.** Sufficient experimental details must be given to enable other workers to repeat the work. The full binominal name should be given for all organisms. The Zoological Code must be strictly followed. Cite the authors of species on their first mention. Use SI units and the appropriate symbols.

**Results.** These should be concise and should not include methods or discussion. Text, tables and figures should not duplicate the same information. New taxa must be distinguished from related taxa. The abbreviations gen. n., sp. n., syn. n. and comb. n. should be used to distinguish all new taxa, synonymies or combinations. Primary types should be deposited in a museum or similar institution. In taxonomic papers the species heading should be followed by synonyms, material examined and distribution, description and comments. All material examined should be listed in similar, compact and easily intelligible format; the information should be in the same language as the text.

Sex symbols should be used rather than "male" and "female".

**Discussion.** This should not be excessive and should not repeat results nor contain new information, but should emphasize the significance and relevance of the results reported.

**References.** The **Harvard** System must be used for the citation of references in the text, e.g. White & Green (1995) or (White & Green 1995). For references with three and more authors the form Brown *et al.* should be used. Authors' names should not be written in capitals. The list of references must include all publications cited in the text but only these. References must be listed in alphabetical order of authors, and both the title and name of the journal must be given in full in the following style:

Penard, E. 1888. Recherches sur le *Ceratium macroceros*. Thèse. Genève, 43 pp.

Penard, E. 1889. Etudes sur quelques Hélozoaires d'eau douce. *Archives de Biologie* 9: 1-61.

Mertens, R. & Wermuth, H. 1960. Die Amphibien und Reptilien Europas, **Kramer, Frankfurt am Main**, XI + 264 pp.

Handley, C. O. Jr. 1966. Checklist of the mammals of Panama, pp. 753-795. In: Wenzel R. L. & Tipton, V. J. (eds).

Ectoparasites of Panama. **Field Museum of Natural History, Chicago**, XII + 861 pp.

References should not be interspaced and, in the case of several papers by the same author, the name has to be repeated for each reference.

The text should be in roman (standard) type face throughout, including headings, with genus and species names underlined with pencil; bold, small capitals, large capitals, italics and other type faces should not be used. Footnotes and cross-references by page should be avoided.

Also, we encourage authors to submit the text on floppy disk (3.5" or 5 1/4", Macintosh or IBM compatible, with "Microsoft Word" or similar programmes). The authors should refrain from using special codes for text formatting.

**Tables.** These should be self-explanatory, with the title at the top organised to fit 122 x 180 mm. Each table should be typed, double spaced, on a separate page and numbered consecutively and its position indicated in the text.

**Figures.** These may be line drawings or half tones and all should be numbered consecutively, and their position indicated in the text. Figures should be arranged in plates which can be reduced to 122 x 160 mm. Drawings and lettering should be prepared to withstand reduction. Magnification should be indicated with scale lines. Authors should refrain from mixing the drawings and half tones. Original drawings will not be returned automatically. The *Revue suisse de Zoologie* declines responsibility for lost or damaged slides or other documents.

**Legends to figures.** These should be typed in numerical order on a separate sheet.

**Proofs.** Page proofs only are supplied, and authors may be charged for alterations (other than printer's errors) if they are numerous.

**Offprints.** The authors receive 25 offprints free of charge; more copies may be ordered at current prices when proofs are returned.

**Correspondence.** All correspondence should be addressed to

Revue suisse de Zoologie

Muséum d'histoire naturelle

CP 6434

CH-1211 Genève 6

Switzerland.

Phone: (022) 418 63 33 - Fax (022) 418 63 01

e-mail: volker.mahnert @ mhn.ville-ge.ch

Home page RSZ: <http://www.ville-ge.ch/musinfo/mhng/page/rsz.htm>







HECKMAN

B I N D E R Y , I N C .

Bound-To-Pleas®

**MAY 00**

N. MANCHESTER, INDIANA 46962

SMITHSONIAN INSTITUTION LIBRARIES



3 9088 01260 2017