

# AIR TANKER PERFORMANCE GUIDES: GENERAL INSTRUCTION MANUAL

D. H. Swanson, C. W. George, and  
A. D. Luedecke

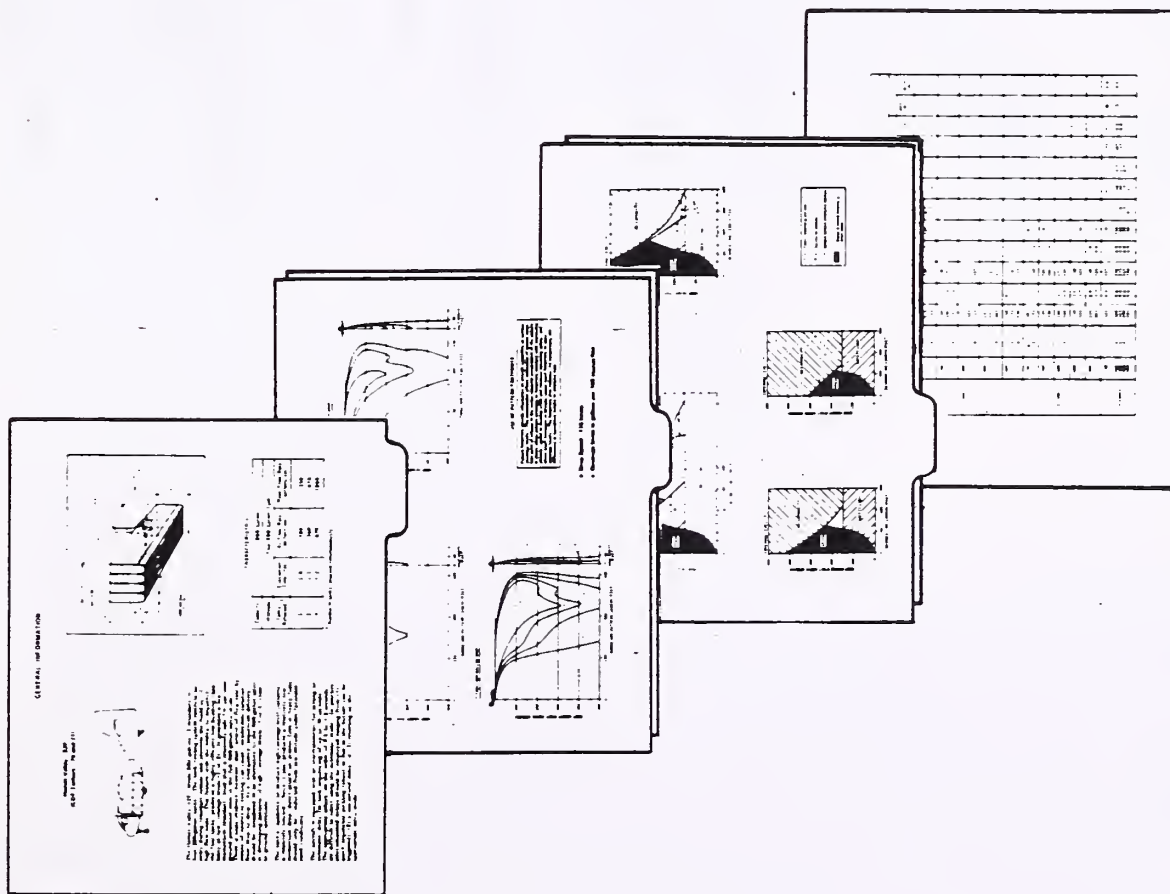

USDA Forest Service  
General Technical Report INT-27  
INTERMOUNTAIN FOREST AND  
RANGE EXPERIMENT STATION



AIR TANKER PERFORMANCE GUIDES:  
GENERAL INSTRUCTION MANUAL

by

D. H. Swanson, Honeywell Inc.  
C. W. George, USDA Forest Service  
A. D. Luedecke, Honeywell Inc.

This manual is published as a part of a program to improve fire control technology through the use of fire-retarding chemicals and delivery systems designed for specific fuels and fire situations. Information or questions regarding these studies and requests for performance guides for specific aircraft should be directed to the authors at:

Northern Forest Fire Laboratory  
Drawer G  
Missoula, Montana 59801

or

Honeywell Inc.  
Government and Aeronautical Products Division  
600 Second Street Northeast  
Hopkins, Minnesota 55343

Additional copies of this publication  
should be ordered from:

USDA Forest Service  
Intermountain Forest and Range Experiment Station  
Ogden, Utah 84401

Use of trade\* or firm names is for reader information only and does not constitute endorsement by the U.S. Department of Agriculture of any commercial product or service.

\* Phos-Chek is a registered trademark of the Monsanto Co.  
Fire-Trol is a registered trademark of the Chemonics Industries  
Gelgard is a registered trademark of the Dow Chemical Co.

DAMON H. SWANSON received his B.A. degree, Phi Beta Kappa, from the State University of Iowa in 1957. He is a Staff Systems Engineer in the Honeywell Government and Aeronautical Products Division. Since May 1972, he has been Project Manager of Honeywell contracts for the USDA Forest Service on Aerial Delivery of Fire Retardants. Prior experience includes 5 years as an Engineering Supervisor with staff responsibility as Small Systems Product Area Manager and as a New Business Proposals Manager.

CHARLES W. GEORGE was graduated from the University of Montana in 1964 in Forest Engineering. He received his M.S. degree at the University of Montana in 1969. In 1965, he joined the Northern Forest Fire Laboratory staff in Missoula, Montana, where he has conducted studies related to prescribed fire, pyrolysis and combustion, fire retardant chemicals, and aerial fire retardant delivery systems and is currently the leader of the Fire Control Technology research work unit.

ALLEN D. LUEDECKE received his bachelor's and master's degree in Mathematics from the University of Montana in 1961 and 1963, respectively. From 1963 to 1964 and from 1967 to the present he has been primarily responsible for operations research studies related to concept definition, design, use, cost, and performance of military systems under development at Honeywell Inc. He conducted similar studies while employed at Cornell Aeronautical Laboratory (now CALSPAN) during 1965 and 1966. He has been involved with the USDA Forest Service program being conducted at Honeywell since 1972.



This manual and user guide for individual tanker aircraft is intended to:

- △ Introduce a basis for systematic planning so that specific air tankers can be employed in the most effective manner based on their inherent capabilities or limitations and the local fire/fuel situation.
- △ Provide (in association with other guidelines) the ability to relate performance of one tanker to the capabilities of other tankers that may be brought into the area.
- △ Introduce a procedure for evaluating tanker operations so that the most effective method for dropping can be identified for the local situation.

Air tankers differ considerably in their capabilities and limitations because of tank design, tank sequence options, retardant quantities, and aircraft flight characteristics. When an aircraft, in concert with the locally available retardant and usage patterns refined over years of practical experience, is singularly effective in a local fire/fuel situation, that aircraft will become an acknowledged favorite. A different aircraft assigned to the same task may appear totally ineffectual by comparison, even though it too may be a favorite in other regions where usage patterns, retardants, or the like are different.

Recently, the understanding of tanker performance has been advanced at the Northern Forest Fire Laboratory. If we know what makes a good drop from one aircraft in a given local situation, we can adjust the usage pattern of a different aircraft to most closely approximate performance of the favored tanker. We can also begin to recognize situational changes from day to day or hour to hour that influence delivery conditions--that change the drops delivered in identical ways from excellent to poor between morning and afternoon.

Despite advances in tanker understanding, there are still many unknowns related to the local fire situation. For this reason, many of the baseline values issued in these guidelines are points of departure that should be refined based on experience and intelligent experimentation. The guidelines will, if properly used, provide a method of quantitatively assessing the good drops versus the bad drops.

For example, if your favorite aircraft is covered by the guides available, think back to a drop that was particularly effective. By estimating drop height at tank release you can determine from the curves presented the pattern value and certain other characteristics of the pattern. These characteristics, then, provide the critical viewpoint by which we refine our intuition and subsequently attempt to tailor the performance of air tankers for most effective usage. Recordkeeping is an important part of guidelines application.

Although experience is invaluable in developing usage patterns for the local situation, even better ways of using favorite aircraft can be found. Some of the views presented here may seem inconsistent with your understanding of aerial firefighting; nonetheless, our views, intuitions, and habits of employing the air tanker have evolved from the water bomber to current retardant aircraft.

Past recommendations are weighted heavily by the preponderance of TBM's and other low-capacity aircraft. They are influenced by firefighting with conventional hoses (and there are both similarities and startling differences). Because of this influence, current aircraft usage may be less than optimum. This document therefore provides, in addition to guidelines, a basis for experimentation, so that even better usage patterns can be identified for more efficient and effective fire management through the use of air tankers.

Guides for specific aircraft that have been evaluated are available from:

The Northern Forest Fire Laboratory  
 Drawer G  
 Missoula, Montana 59801

CONVENTIONAL FIREFIGHTING HAS SOME SIMILARITIES TO AIR TANKER ATTACK

In conventional firefighting, retardant or water is continuously applied to completely extinguish the fire by several means:

- Δ Cooling fuels and gases near the reaction zone.
- Δ Coating fuel surfaces to deprive the surface of heat and oxygen.

Optimized techniques attempt to tailor application rates (gal/sec) to reduce time of application by minimizing runoff--the amount of material that is not effective in achieving extinction.

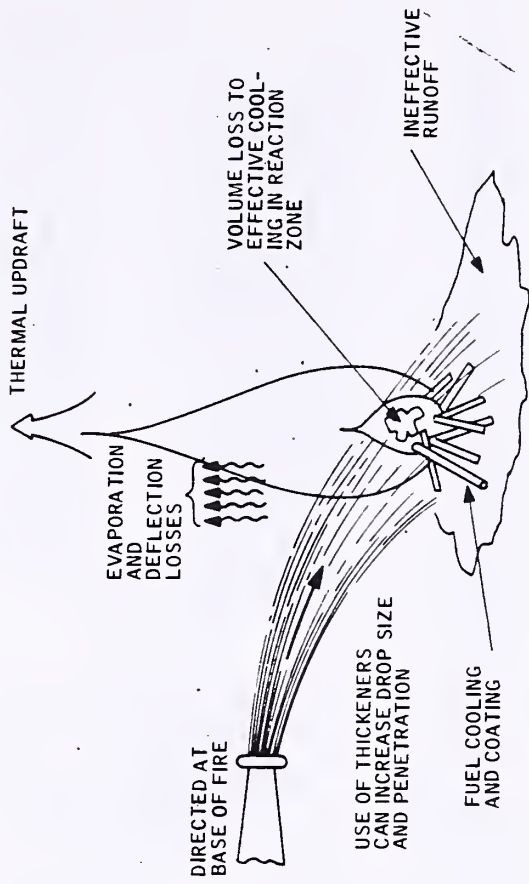

A SPRINKLER SYSTEM OPERATES FROM ABOVE THE FIRE-- ILLUSTRATING BOTH THE PROBLEMS AND PRINCIPLES OF AIR TANKER ATTACK

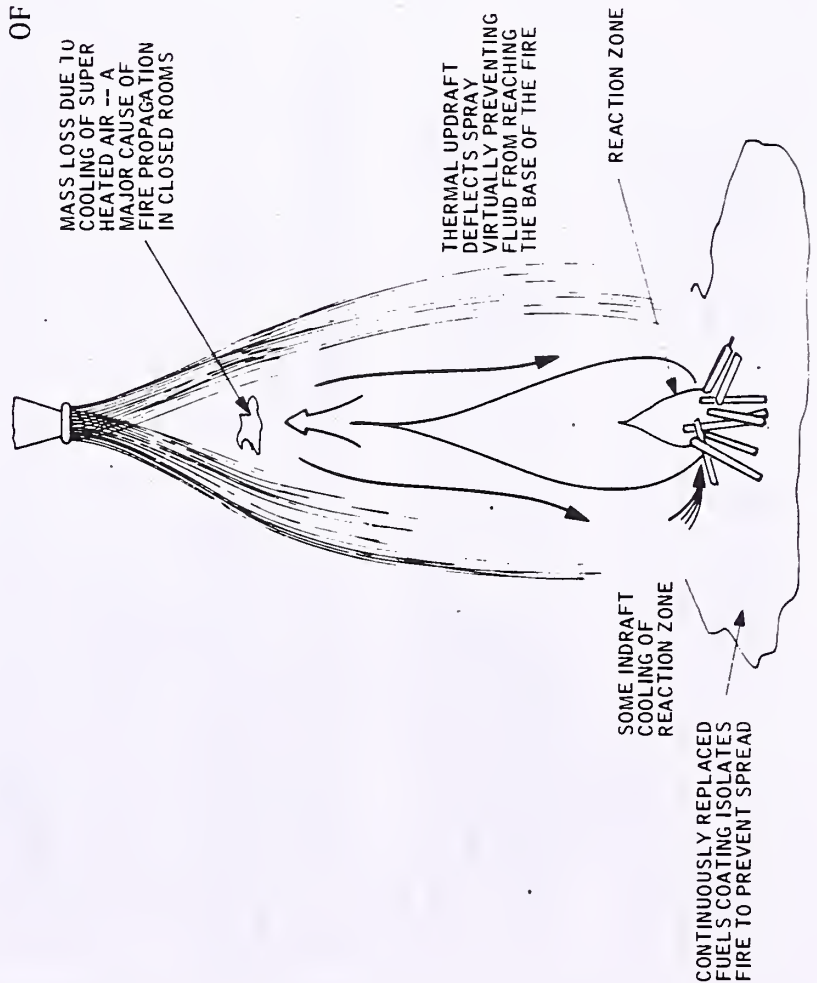

A sprinkler system is not generally credited with the capability of direct suppression because the thermal updraft protects the flame like an umbrella. Instead, it operates against the fire-spread mechanisms by cooling the superheated air and "fireproofing" adjacent fuels.

Thickeners increase drop size, and consequently their penetration into the fire plume.

**SIMILARITIES AND DIFFERENCES**

The air tanker attacking the fire from overhead is similar in some respects to the sprinkler. The combination of a driving wind and thermal updraft largely deflects drops toward the fuels in front of the fire.

Unlike the sprinkler, mass losses taken in cooling superheated air above the fire do little to reduce the spread rate since radiation from the convection column does not contribute significantly to fire spread.

Fuel coating (from water content and thickeners), fuel modification (from the retardant salts), and fuel cooling (from the water content) are the major fire-suppressing agents in retardants.

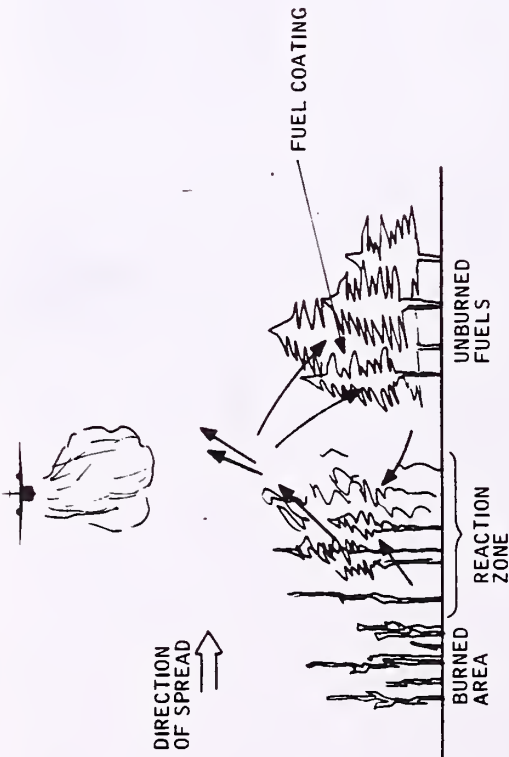

Conventional firefighting uses time of application to cool or starve the fire to extinction.

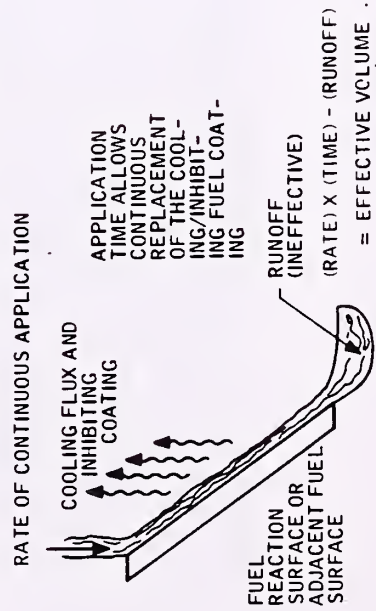

**LONG-TERM BENEFITS:** The retardant salts continue to alter pyrolysis of combustion mechanisms long after the water content has been dissipated. This effect becomes more significant in aerial retardant delivery than the benefits of fuel cooling and coating from the water content of the retardant alone.

Air delivery applies all of the retardant at once and must rely on the fuel surface to retain an adequate amount to extinguish, knock down, or retard the fire.

Effective volume is that retained by the fuel surface. The addition of thickening agents can increase the volume retained on the fuel and slow runoff.

Since the fuel surfaces are limited in the amount of retardant they can retain, any excess application will ultimately be lost as runoff.

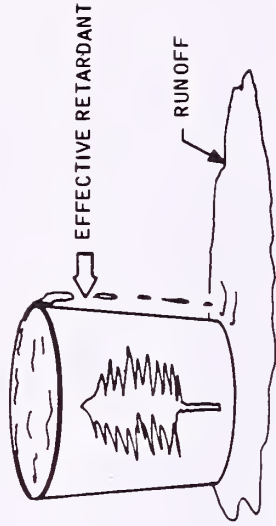

This factor places practical limits on the useful coverage levels in retardant ground patterns.

It also means that in most cases of direct attack, retardant effects on adjacent fuels are as significant as those on the reaction zone itself.

**FIRE:** Although dripping and running prolong the continuous effects of the brief application, the total effect is limited to what can be achieved in something less than one minute -- few fires are extinguished by conventional techniques in a matter of minutes regardless of application rate.

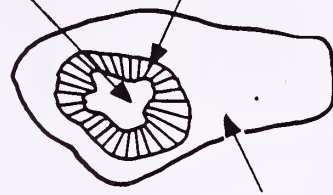

**SHORT-TERM BENEFITS:** Limits of the short-term benefits of fuel cooling and coating from the water content of retained retardant. If the effect lasts long enough to resist fire spread to new fuels, delayed extinction will result.



RECOMMENDED COVERAGE LEVELS

Recommended coverage levels are based on studies of fuel surface capacities, retardant salt effects, moisture damping effects, and knowledge of the pattern capabilities of aircraft known to be effective in certain fire situations. The coverage levels are related to fuel models contained in the National Fire-Danger Rating System.

COVERAGE LEVEL	RECOMMENDED FUEL MODEL	DESCRIPTION
1	A	GRASSES, TUNDRA, AND OPEN DESERT SHRUBLANDS
2	C F	CONIFER TIMBER WITH GRASS UNDERSTORY BRUSHFIELDS WITH MUCH GREEN MATERIAL
3	D E H	SHRUBLANDS UNDER 6 FEET IN HEIGHT (SUCH AS SAGEBRUSH) HARDWOOD LITTER AFTER LEAF DROP CLOSED CONIFER TIMBER WITH LITTER ONLY
4 OR MORE	B G I	HARD CHAPARRAL AND OTHER HIGH (6-FOOT) FLAMMABLE SHRUBS CLOSED, OLD CONIFER TIMBER WITH LITTER AND DEAD, DOWN LIMB WOOD CONIFER SLASH

FOR CREEPING OR SMOLDERING FIRES, REDUCTION OF ONE COVERAGE LEVEL MAY BE CONSIDERED.

Coverage levels expressed in gallons per 100 square feet (gpc), are derived from the fuel surface area and the effect of retardant salts on spread rate in typical fuels. Coverage levels are tempered by personal knowledge of aircraft performance in certain fire situations. For example, the Bureau of Land Management has confidence in the use of trail systems against grass fires. Such systems produce considerable line at levels ranging from 0.5 to 2 gallons per 100 square feet.

ONE GALLON PER 100 SQUARE FEET IS ABOUT 1-1/2 TABLESPOONS SPREAD EVENLY ON THIS PAGE.

EVEN AT HIGHER COVERAGE LEVELS THE AMOUNT IS NOT GREAT -- IT IS EQUIVALENT TO THE DEPTH OF MATERIAL BELOW

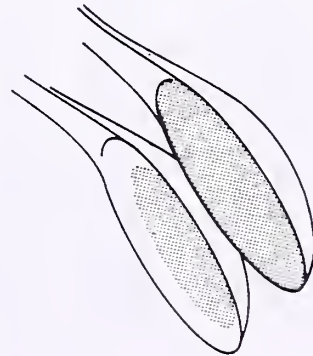

(Equivalent inches of rainfall)

RETARDANT PATTERNS

A retardant pattern maps retardant distribution on the ground in terms of effective coverage levels. The pattern provides a means for evaluating the effects of the drop on the fire/fuels by examining the area, length, and width of the pattern at its various coverage levels.

This three-dimensional representation of the retardant pattern resembles a mountain range emerging from a plateau. It shows how the coverage level, measured in gallons per 100 square feet, fluctuates over the drop area. The vertical coverage level is greatly exaggerated here.

△ The mountain range contains the coverage levels of 1 to 4 recommended in these guides.

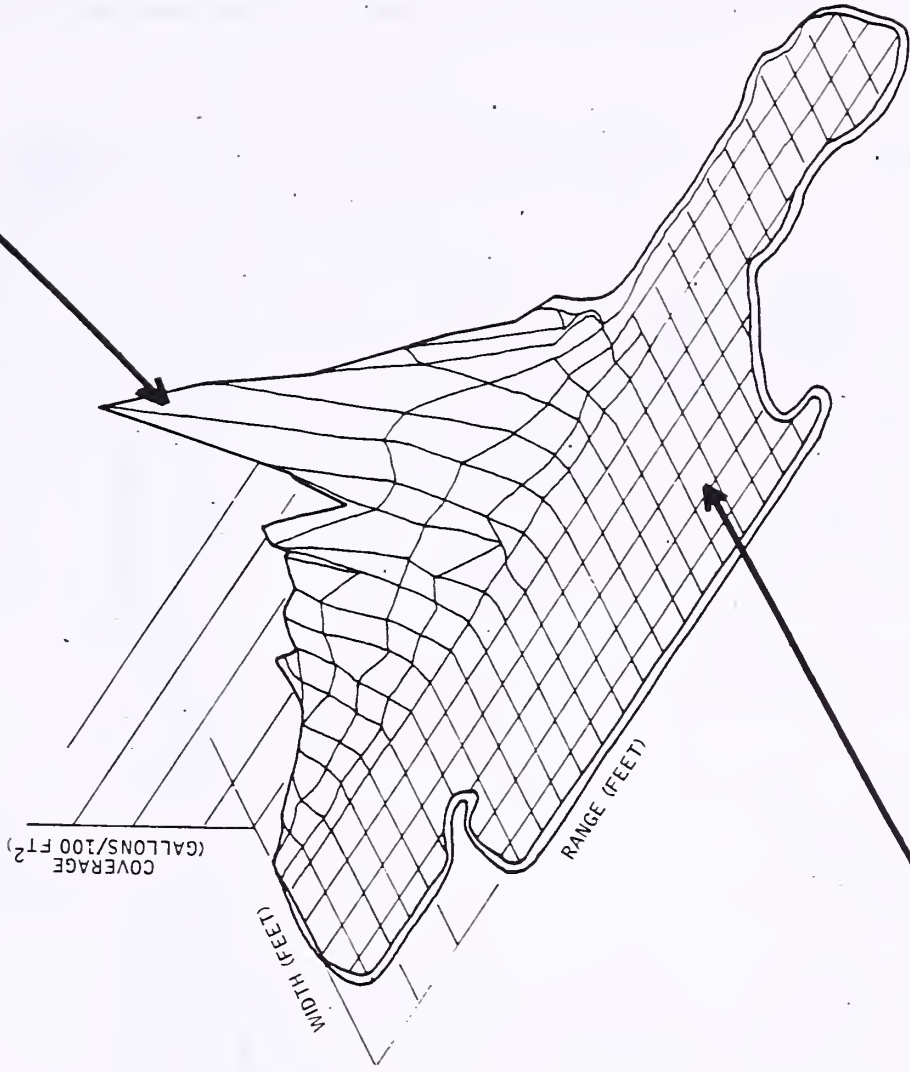

△ The plateau represents a very low coverage level or trace precipitation, typically about 1/10 of the lowest recommended coverage level.

When presented in terms of an elevation map that delineates specific coverage levels, the pattern's effectiveness can be evaluated in various fire situations.

- △ Considerable areas of the pattern are at coverage levels in excess of that required. They are effective, but the excessive gallonage could be better used if spread over a larger area.
- △ Some areas are inadequately covered. They have more limited effectiveness and may in many cases be ignored.

There are three important characteristics of any pattern.

- △ Length at a given coverage level.
- △ Width at a given coverage level.
- △ The momentum of the retardant mass as it falls to the ground.

LENGTH is a direct measure of the line applied in front of the fire. It is also the pattern dimension that accommodates range errors in placing the pattern accurately. Length is controllable by proper selection of the tank release options available to the pilot.

WIDTH is the pattern dimension that accommodates cross-range errors in placing the pattern. Its influence on the fire is difficult to evaluate quantitatively, and it is not generally controllable. Increased width is viewed as a benefit, but is not considered variable in these guidelines.

MOMENTUM refers to the velocity and mass of the retardant as it approaches the ground. It determines where the central core of the pattern will land with respect to the release point. High-momentum drops shoot far down range from the release point, resist wind deflection, and penetrate most fire plumes. They yield small areas at very high coverage levels and have the potential to physically break fuel structures (top trees, etc.). As a consequence they are potentially dangerous to ground personnel. The high-momentum portion of the pattern contributes to accuracy and is usually limited to the lower drop heights.

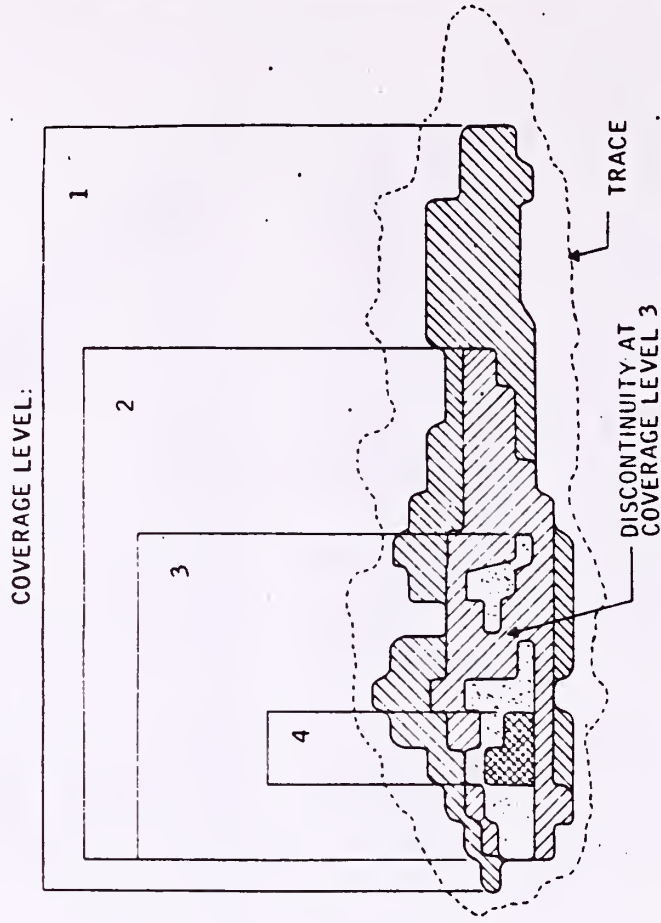

VOLUME FLOW RATE ESTABLISHES TANK AND GATING SYSTEM PERFORMANCE

Volume flow rate from the tank determines retardant distribution pattern. Aircraft velocity, altitude, and retardant type simply modify retardant distribution on the ground.

The flow rate from the CL-215, for example, has the basic form shown below, which is determined by tank geometry, door opening rate, venting, and door area.

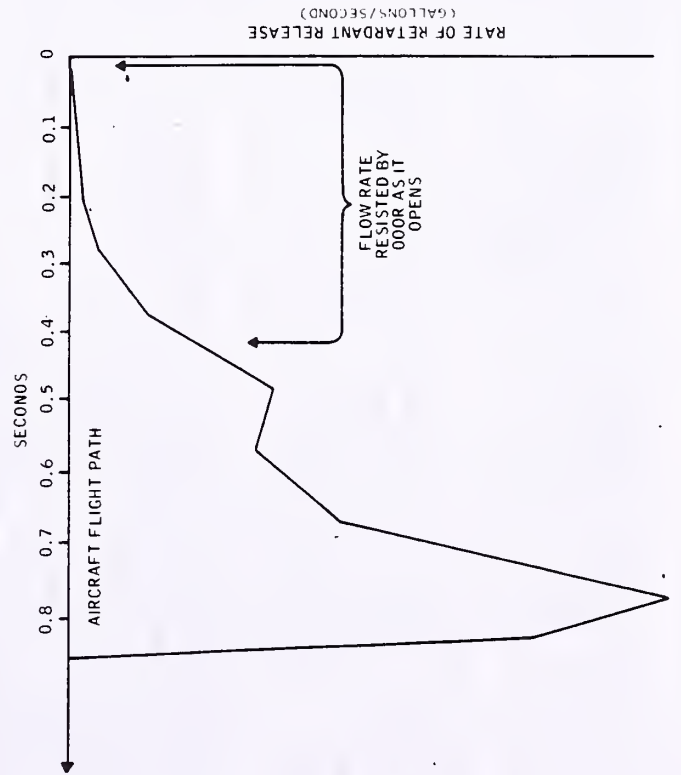

FLOW-RATE-DETERMINED PATTERN CHARACTERISTICS ARE VISIBLE IN RECOVERED GROUND PATTERNS

The three-dimensional plot below shows how flow-rate distribution is reflected in the ground-coverage pattern.

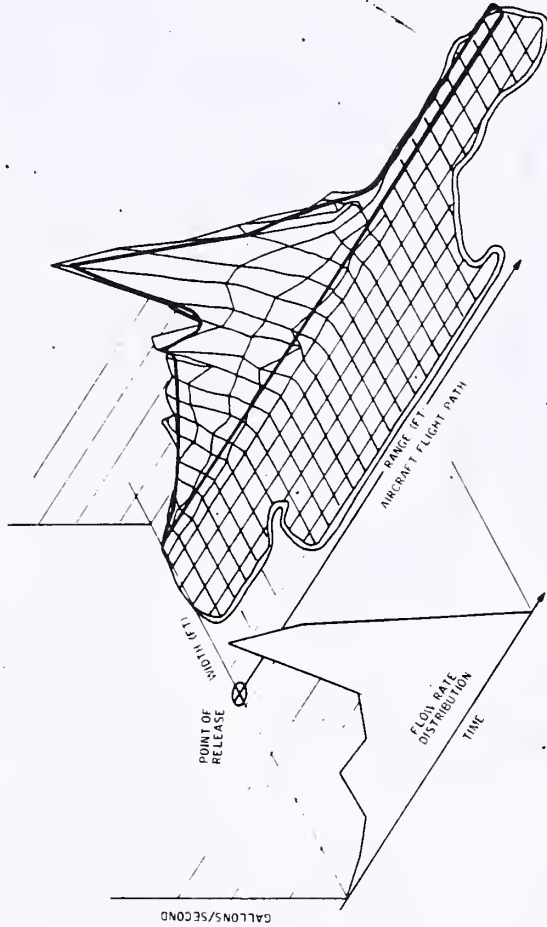

Flow-determined characteristics are retained regardless of the altitude even though actual coverage levels are reduced as the retardant spreads out in width, and loses material to evaporation.

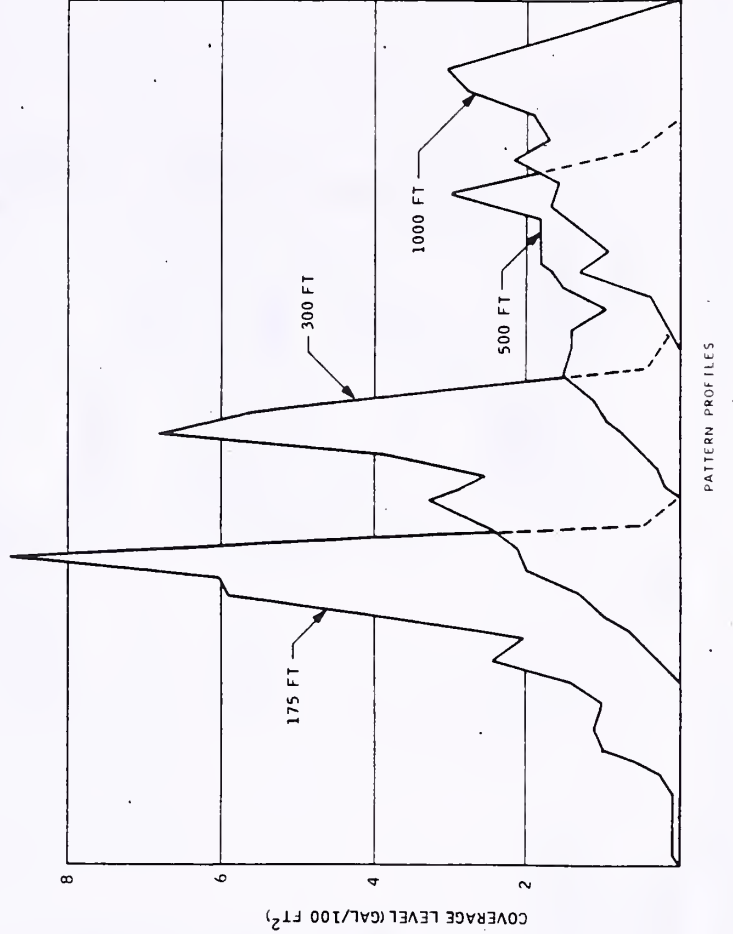

The flow rate from a single tank is fixed by quantity, door-opening rate, tank geometry, venting, and door area. The distribution of retardant in the pattern can be controlled to a limited extent by the selection of aircraft drop height, velocity, and angle of attack.

**DROP HEIGHT**--Increasing the drop height reduces the peak coverage level and momentum of the pattern, and increases pattern width. Its effect on pattern length ranges from small to great depending on the tank design and the retardant type. Because it affects the pattern, aircraft, and ground safety, drop height is a primary variable in these guides.

**AIRCRAFT VELOCITY**--The aircraft velocity with respect to the ground changes the retardant distribution as shown, but its effect on coverage levels is not usually as significant as might be supposed. Flying faster will generally reduce peak coverage values, increase pattern momentum, and increase low coverage lengths. All data in these guides are based on the midvelocity of specific aircraft.

**AIRCRAFT MANEUVER**--The effects of dive or toss modes of release are similar to effects of velocity. Diving tends to foreshorten the pattern and increase coverage levels. The effect is similar to reducing velocity. Toss tends to elongate the pattern. The effect is similar to increasing aircraft velocity. Maneuver selection is more related to the ability to place the pattern accurately than it is to the coverage levels obtained. It is not considered a primary variable in these guides.

**WIND**--The effect of wind is to deflect the pattern and greatly increase the pattern's fringe area. It does not generally diminish pattern area or length significantly at the 1- through 4-gallons-per-hundred-square-foot coverage levels. Like drop height, wind will exert a greater influence on water-like retardants, than on gum-thickened products. The smaller drops are more susceptible to drift, deflection, and increased evaporation losses than the larger drops of gum-thickened retardants. Because the effect is more related to placement accuracy than coverage, all data in the guides are generated under a theoretical no-wind condition.

#### PATTERN PROFILES

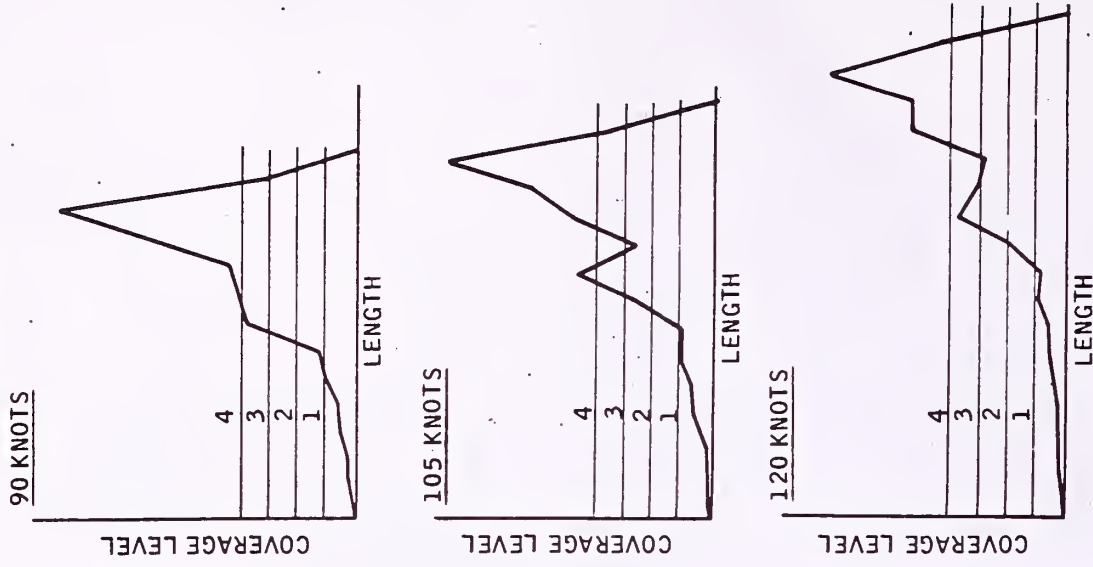

NUMBER OF TANKS DETERMINES  
AIRCRAFT FLEXIBILITY

Most aircraft carry at least two tanks; some contain as many as eight. Considerable control can be exerted on the pattern by the judicious use of the tanking increments available and the time between tank releases.

- Δ Dropping two tanks simultaneously (in salvo) doubles the flow rate and, consequently, the coverage level. It does not necessarily double the length or the area of useful coverage.

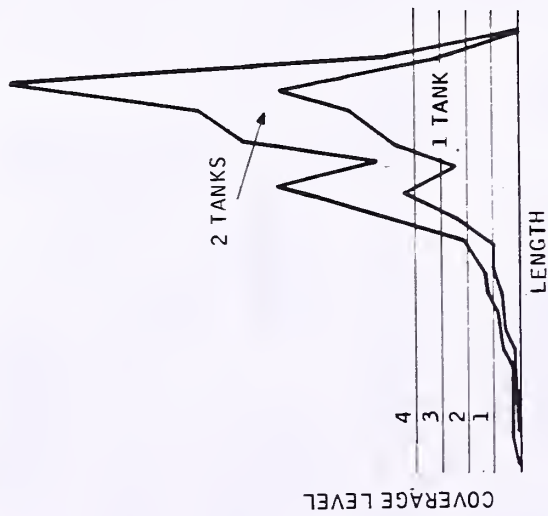

- Δ For some tanking systems, multiple-tank salvos are useful to bring pattern coverage up to the appropriate values: To accommodate the effects of increased altitude or to increase flexibility.

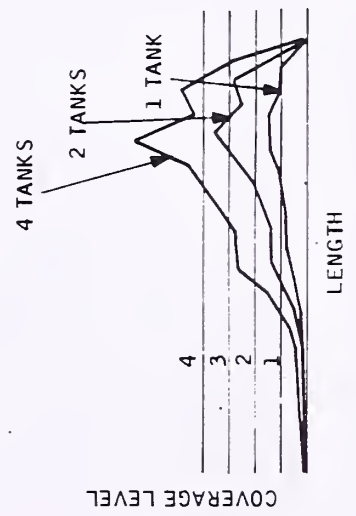

PATTERN CAN BE CONTROLLED  
BY A DELAYED RELEASE SEQUENCE

In most cases, the most efficient use of multiple-tank drops occurs when individual tank releases are spaced along the aircraft flight path. The appropriate delay interval will vary with drop height, aircraft velocity, retardant type, and the desired coverage level. Few aircraft are equipped to regulate delays accurately. Nonetheless, delays can be approximated to maximize pattern length at the required coverage level.

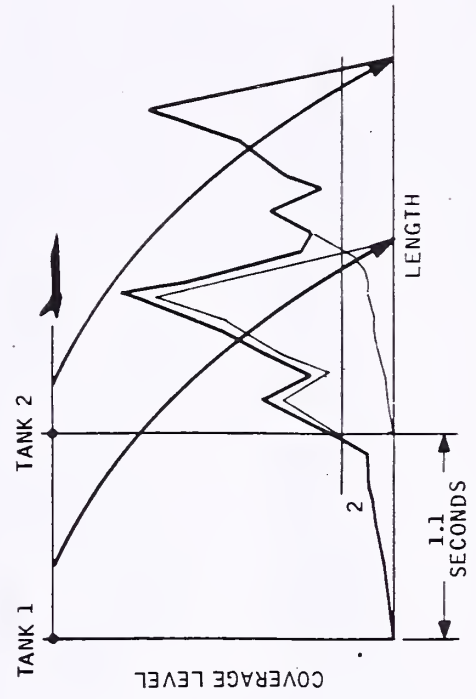
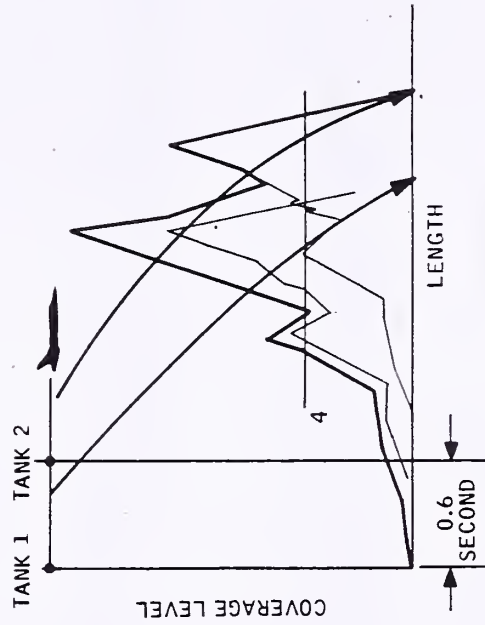

DOOR OPTIONS CAN BE USED TO CONTROL FLOW RATE

Some aircraft offer a choice of doors used in the drop. Depending on the desired pattern level, all or part of the tank bottom can be opened.

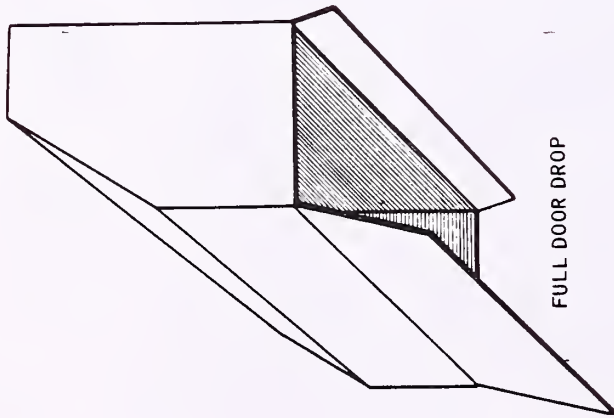

FULL DOOR DROP

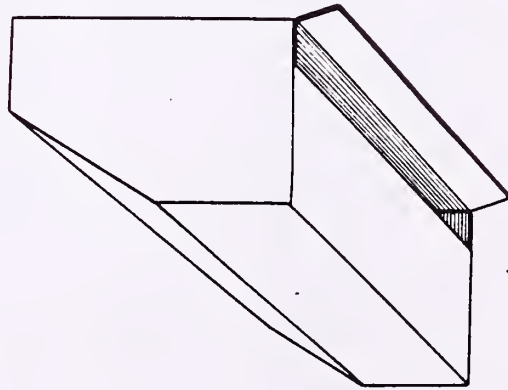

TRAIL DOOR DROP

Flow Rates Available From One Tank With Two Door Options...

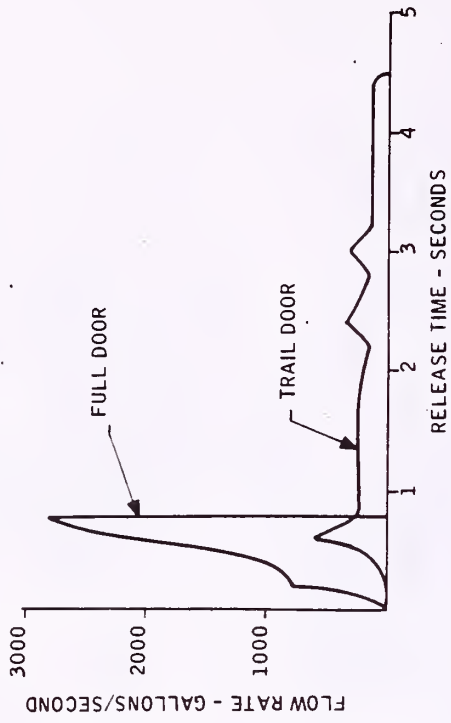

... Yield Two Types Of Ground Pattern

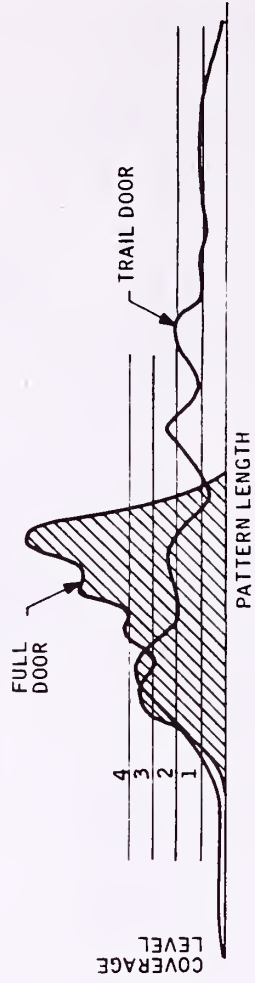

## ORGANIZATION OF USER GUIDES

The User Guides display data on specific aircraft, in forms useful to the tanker pilot, air attack, and ground personnel in achieving the most efficient use of the aircraft.

Each guide contains:

Δ GENERAL INFORMATION--A brief description of the aircraft and its tanking system.

Δ PATTERN FOOTPRINTS--Plots of pattern coverage levels for various types of drops and retardants.

Δ BEST STRATEGY CHARTS--Enabling quick selection of the best number and sequence of tanks to be employed for specific coverage requirements and line length.

Δ DETAILED TABLES--Showing the line length and specific settings for delayed release to achieve maximum coverage at a large number of coverage levels and altitudes.

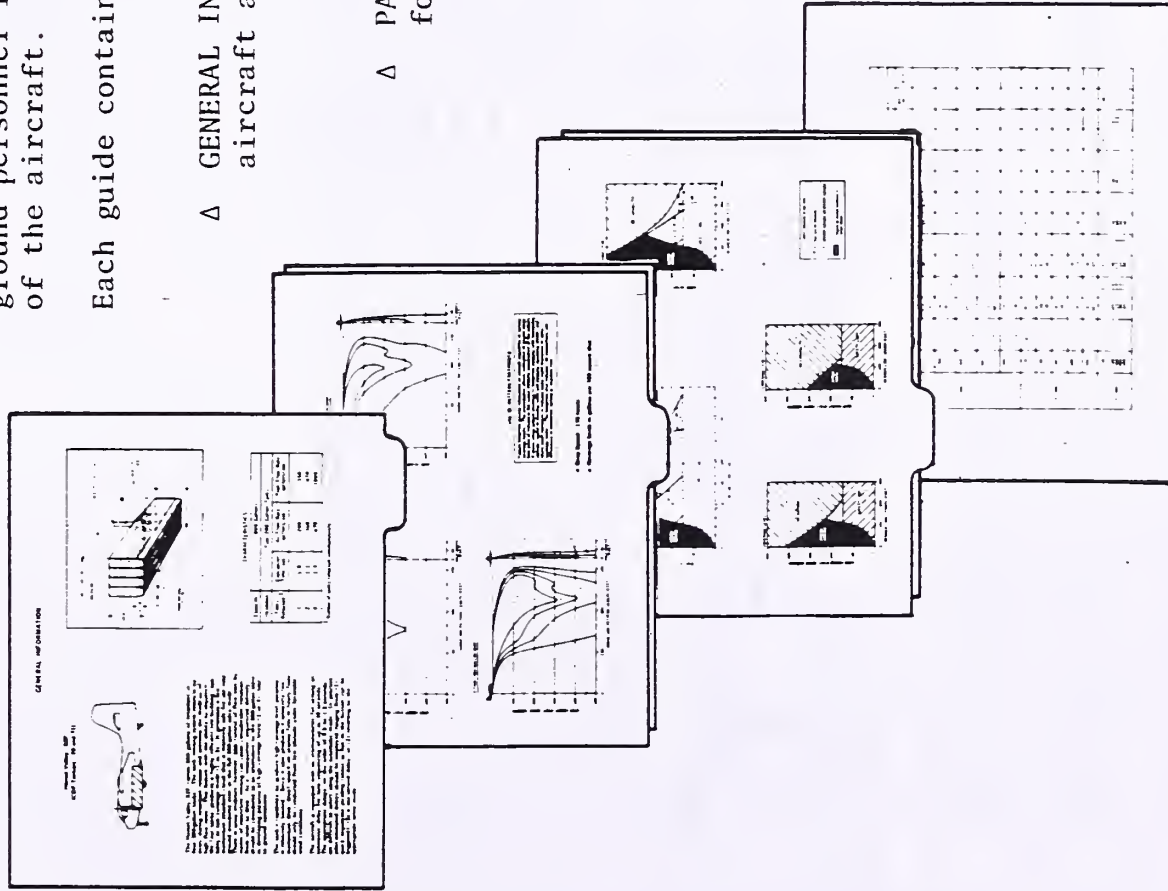

The following pages discuss the use of this information.

USE OF "GENERAL INFORMATION" SECTION

The general information section contains three elements:

- Δ A description and assessment of the aircraft tanking system in terms of its limitations and capabilities. It is particularly useful in comparing the aircraft with others that might be used in the region, so that differences in tankers' employment are apparent.
- Δ A schematic of the tank showing the pattern control options available.
- Δ A table of characteristics showing typical tank evacuation times, retardant capacities, and average and peak flow rates.

Using these data, it is possible to compare aircraft quickly. Performance similar to that of a familiar aircraft will generally occur under conditions where the average flow rates are comparable. For example: A 1,000-gallon tank with a 235-gallons-per-second flow rate is known to produce patterns effective against fires in your region. A new tanker with four 200-gallon tanks becomes available that offers 200-, 400-, and 800-gallons-per-second flow-rate options. Comparable coverage levels (but considerably shorter patterns) will be obtained using the 200-gallons-per-second (single tank) release under similar delivery conditions. Conversely, if an 800-gallon tank with 1,000-gallons-per-second peak flow has been used effectively in close-support operations, an apparently comparable 750-gallon tank producing a 2,000-gallons-per-second peak flow can be recognized as a potential hazard to ground personnel if flown at the same delivery altitude.

Δ Average Flow Rate: An indicator of coverage levels generated in the pattern--the lower the value, the lighter the pattern.

Δ Peak Flow Rate: An indicator of the pattern's momentum. Values much above 1,000 gallons per second should be considered as potentially dangerous to ground personnel when released at low altitude.

GENERAL INFORMATION

Hemlock Valley, 52F (GDF Tanker - 70 and 71)

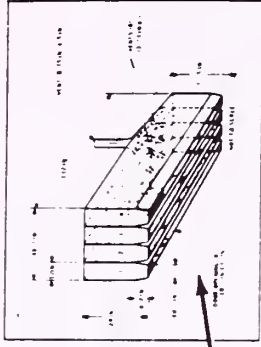

The Hemlock Valley 52F carries 800 gallons of retardant for low altitude use. The retardant is released from the aircraft during straight and level flight. The aircraft has the ability to release the retardant in a pattern that is relatively safe for the rear seat crew. The aircraft is equipped with a means of restrictive venting can cause considerable variation in developing patterns of high coverage levels (3 or 4) close to ground operations.

The tank's capability to produce high coverage level patterns is relatively limited. Since it also produces a relatively low, wind conditions. The aircraft is equipped with an interometer for setting an automatic delay for tank sequencing of up to 30 seconds. The delay is adjustable in 1 second increments. The pilot-estimated delays should be employed ranging from 11 to 15 seconds. The delay should be set as low as the bottom can be quick sequential picking (about as fast as the bottom can be appropriate salvo) made.

CHARACTERISTICS			
800 Gallons			
Capacity	Increment	Av Flow Rate (gallons/sec)	Peak Flow Rate (gallons/sec)
1	1	1.0	350
2	2	1.1	670
4	4	1.2	1000

Number of tanks released simultaneously

CHARACTERISTICS

800 Gallons			
Four 200-Gallon Tanks			
Capacity	Increment	Evacuation Time (sec)	Peak Flow Rate (gallons/sec)
1	1	1.0	350
2	2	1.1	670
4	4	1.2	1000

Number of tanks released simultaneously



RETARDANT FOOTPRINTS

Retardant footprints indicate aircraft capability at various coverage levels over a range of altitude. Patterns are generated at the mid-range of aircraft speed. The following factors can be determined by examining the footprint:

- (A) Approximate distance from point of release to the center of the pattern, the point of highest concentration. This distance is useful in estimating the amount of lead required to place the pattern on spot fires.
- (B) The approximate length of pattern at a given coverage level and drop height. This value in association with observed fire response can be used to check or refine the recommended coverage level values in specific fire situations.
- (C) The effect of altitude on pattern width. Note in this case the maximum area coverage at 1 occurs around 190 feet where the width is greatest just prior to the reduction in length (E).
- (D) Noncritical drop heights. The pattern is relatively insensitive to uncontrolled variables within this range. Small changes of altitude do not cause the pattern to drop below the recommended coverage level.
- (E) A critical drop height, where the pattern line (at level 2) falls off rapidly, can become discontinuous, and is sensitive to variables such as wind or drop height.
- (F) An indication of the drop height at which the retardant mass loses its forward velocity and falls vertically.
- (G) An indication of the drop height at which the retardant mass loses its forward velocity and falls vertically.

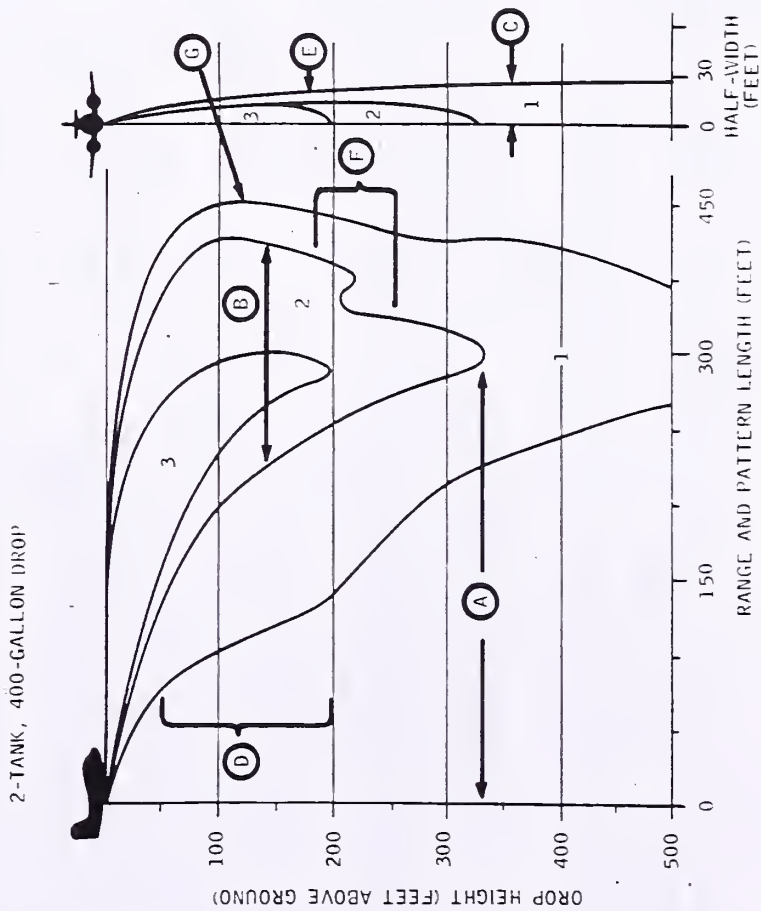

USING RETARDANT FOOTPRINTS  
TO ESTIMATE EFFECTIVE COVERAGE LEVEL

A hypothetical 800-gallon drop (A) was made from the Hemet Valley-S2F using Fire-Trol 100 (B) at an estimated drop height of 200 feet (C).

The line boss estimated that the drop pattern was effective over not more than 150 feet (D).

From the footprint, the coverage level appropriate to the specific fire fuel situation can be estimated as shown at right. By comparing the estimated effective length with the coverage level profiles, we can estimate the minimum useful coverage at about 3 (E).

Subsequent evaluation showed the fire was absolutely extinguished for about 50 feet along the flight path.

From the Line Length/Opening Delay Tables, the coverage level for extinction can be estimated by examining the estimated lengths at higher coverage associated with the drop (F).

By this process, in association with intelligent experimentation, it is possible to utilize an aircraft with reasonably well-defined drop characteristics to gather important information on the effect of retardants on actual fires. For this reason, drop postmortems and data collection are encouraged.

Pattern Coverage Characteristics - WATERLIKE Retardants  
(B) [Fire-Trol 100, Fire-Trol 931 (LC) and Water]

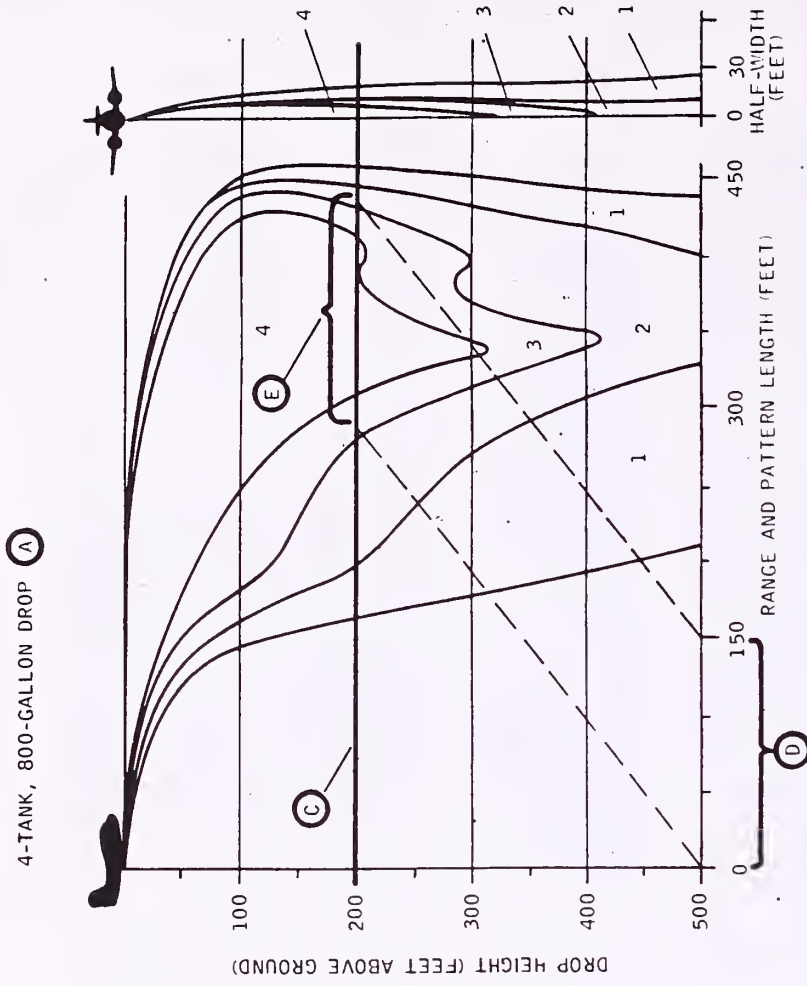

NO. OF TANKS RELEASED AT A TIME	DROP HEIGHT (FT)	NO. OF PATTERNS	COVERAGE GALLONS 100 FT?																	
			LEVEL 1				LEVEL 2				LEVEL 3				LEVEL 4					
			0.5	1.0	2.0	3.0	4.0	6.0	0.5	1.0	2.0	3.0	4.0	6.0	0.5	1.0	2.0	3.0	4.0	6.0
			MAX LENGTH (FT)	DELAY (SEC)	MAX LENGTH (FT)	DELAY (SEC)	MAX LENGTH (FT)	DELAY (SEC)	MAX LENGTH (FT)	DELAY (SEC)	MAX LENGTH (FT)	DELAY (SEC)	MAX LENGTH (FT)	DELAY (SEC)	MAX LENGTH (FT)	DELAY (SEC)	MAX LENGTH (FT)	DELAY (SEC)	MAX LENGTH (FT)	DELAY (SEC)
(A) 4 TANKS	150	2	505	1.3	245	0.0	0.0	0.0	0.0	0.0	0.0	0.0	0.0	0.0	0.0	0.0	0.0	0.0	0.0	0.0
	200	1	325	0.0	295	0.0	0.0	0.0	0.0	0.0	0.0	0.0	0.0	0.0	0.0	0.0	0.0	0.0	0.0	0.0
	300	1	320	0.0	270	0.0	0.0	0.0	0.0	0.0	0.0	0.0	0.0	0.0	0.0	0.0	0.0	0.0	0.0	0.0
	400	1	315	0.0	250	0.0	0.0	0.0	0.0	0.0	0.0	0.0	0.0	0.0	0.0	0.0	0.0	0.0	0.0	0.0
	500	1	290	0.0	240	0.0	0.0	0.0	0.0	0.0	0.0	0.0	0.0	0.0	0.0	0.0	0.0	0.0	0.0	0.0
			235	0.0	240	0.0	0.0	0.0	0.0	0.0	0.0	0.0	0.0	0.0	0.0	0.0	0.0	0.0	0.0	0.0

NO. OF TANKS RELEASED AT A TIME	DROP HEIGHT (FT)	NO. OF PATTERNS	COVERAGE GALLONS 100 FT?																	
			LEVEL 1				LEVEL 2				LEVEL 3				LEVEL 4					
			0.5	1.0	2.0	3.0	4.0	6.0	0.5	1.0	2.0	3.0	4.0	6.0	0.5	1.0	2.0	3.0	4.0	6.0
			MAX LENGTH (FT)	DELAY (SEC)	MAX LENGTH (FT)	DELAY (SEC)	MAX LENGTH (FT)	DELAY (SEC)	MAX LENGTH (FT)	DELAY (SEC)	MAX LENGTH (FT)	DELAY (SEC)	MAX LENGTH (FT)	DELAY (SEC)	MAX LENGTH (FT)	DELAY (SEC)	MAX LENGTH (FT)	DELAY (SEC)	MAX LENGTH (FT)	DELAY (SEC)
(A) 4 TANKS	150	2	505	1.3	245	0.0	0.0	0.0	0.0	0.0	0.0	0.0	0.0	0.0	0.0	0.0	0.0	0.0	0.0	0.0
	200	1	325	0.0	295	0.0	0.0	0.0	0.0	0.0	0.0	0.0	0.0	0.0	0.0	0.0	0.0	0.0	0.0	0.0
	300	1	320	0.0	270	0.0	0.0	0.0	0.0	0.0	0.0	0.0	0.0	0.0	0.0	0.0	0.0	0.0	0.0	0.0
	400	1	315	0.0	250	0.0	0.0	0.0	0.0	0.0	0.0	0.0	0.0	0.0	0.0	0.0	0.0	0.0	0.0	0.0
	500	1	290	0.0	240	0.0	0.0	0.0	0.0	0.0	0.0	0.0	0.0	0.0	0.0	0.0	0.0	0.0	0.0	0.0
			235	0.0	240	0.0	0.0	0.0	0.0	0.0	0.0	0.0	0.0	0.0	0.0	0.0	0.0	0.0	0.0	0.0

## UPSLOPE AND DOWNSLOPE DROPS

The retardant footprints can also be employed to estimate the coverage achievable and approximate release points in terms of altitude and range for drops against severe slopes. In the example at right, a 30% grade is shown as a rise of 135 feet over the 450-foot span of the graph. A straight-edge moved across the footprint at the appropriate angle allows assessment of appropriate release strategy or the ground coverage levels developed. With some additional calculations, the capability of the aircraft to accomplish the drop and to escape safely can be examined under various terrain-clearance conditions.

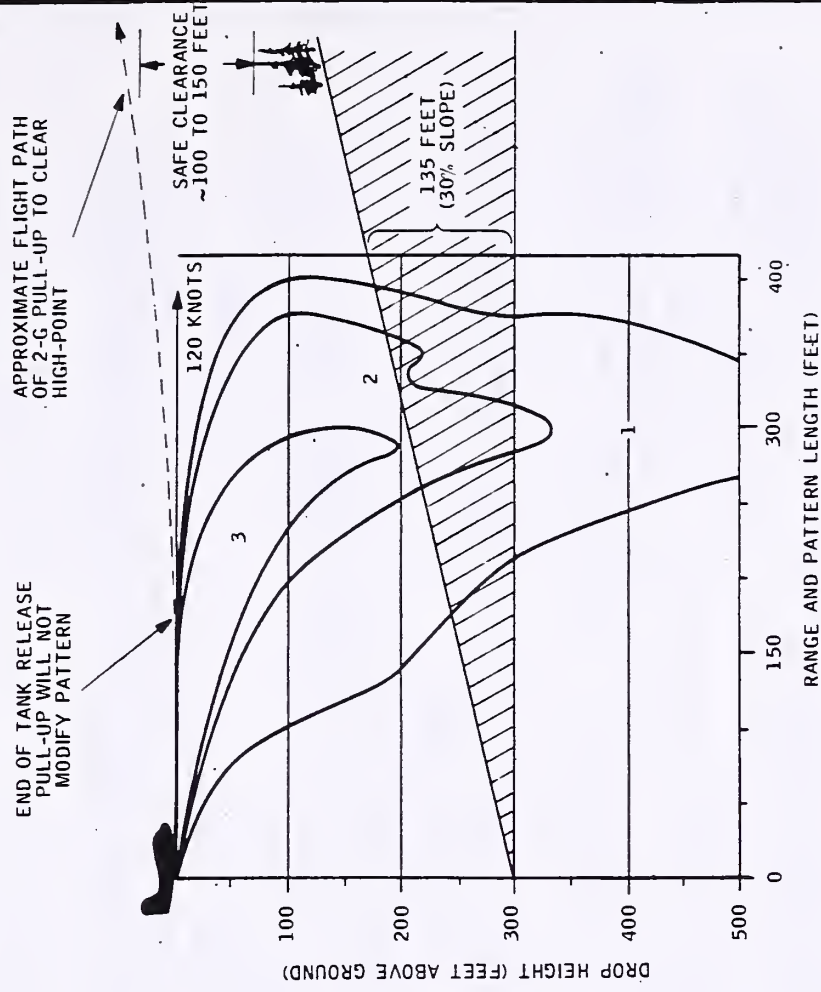

## BEST STRATEGY CHARTS

Best Strategy Charts summarize the Line Length/Opening Delay Tables to allow quick identification of the number of tanks and approximate delays between releases that will achieve the most efficient use of the retardant load for any combination of coverage level, line length, and drop height. A key to use accompanies the charts.

The charts illustrate several important points:

First, selection of a coverage level that is too high may produce a large reduction in efficiency, particularly

when low levels will suffice. Tanking systems lose flexibility when used to apply excessively heavy coverage.

Second, the Charts show ground personnel and mission planners what can specifically be expected from the aircraft. It allows assessment of whether the use of a full load (dropping maximum line), higher coverages, or multiple drops are more efficient in a given fire attack situation.

Finally, the Charts show the limits of accuracy and safety of ground personnel in direct-attack or close-support operations.

USE OF BEST STRATEGY CHARTS

**(A)** Select the chart for the retardant type to be employed in the operations. This will be GUM-THICKENED (such as Phos-Chek) or WATERLIKE (such as Fire-Trol 100).

**(B)** Select the chart for the appropriate coverage level for fuel and fire situations in the area of operations.

COVERAGE LEVEL	RECOMMENDED FOR: FUEL MODEL	DESCRIPTION
1	A	GRASSES; TUNDRA, AND OPEN DESERT SHRUBLANDS
2	C F	CONIFER TIMBER WITH GRASS UNDERSTORY BRUSHFIELDS WITH MUCH GREEN MATERIAL
3	D	SHRUBLANDS UNDER 10 FEET IN HEIGHT (SUCH AS SAGEBRUSH)
4 OR MORE	E H B G I	HARDWOOD LITTER AFTER LEAF DROP CLOSED CONIFER TIMBER WITH LITTER ONLY HARD CHAPARRAL AND OTHER HIGH (6'-FOOT) FLAMMABLE SHRUBS CLOSED, OLD CONIFER TIMBER WITH LITTER AND DEAD, DOWN LIMB WOOD CONIFER SLASH

FOR CREEPING OR SMOLDERING FIRES, REDUCTION OF ONE COVERAGE LEVEL MAY BE CONSIDERED.

**(C)** Estimate the length of line required for a particular drop at the selected coverage level.

**(D)** Determine drop-height limits: (1) to assure aircraft safety in clearance of terrain features both before and after the planned release and (2) to protect ground personnel in close-support operations.

**(E)** Identify the region on the chart defined by the line-length, drop-height condition. This will identify the best release strategy to achieve the required coverage:

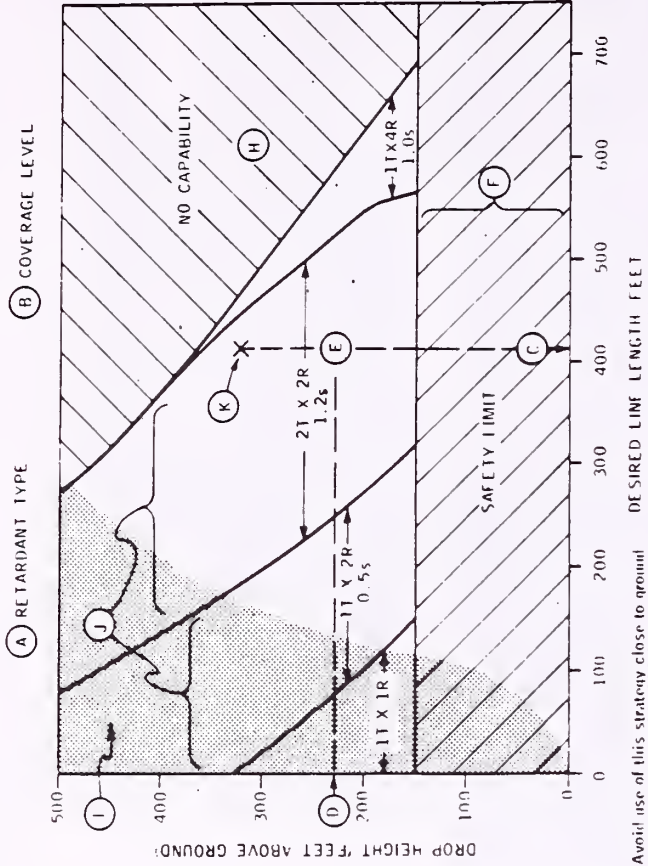
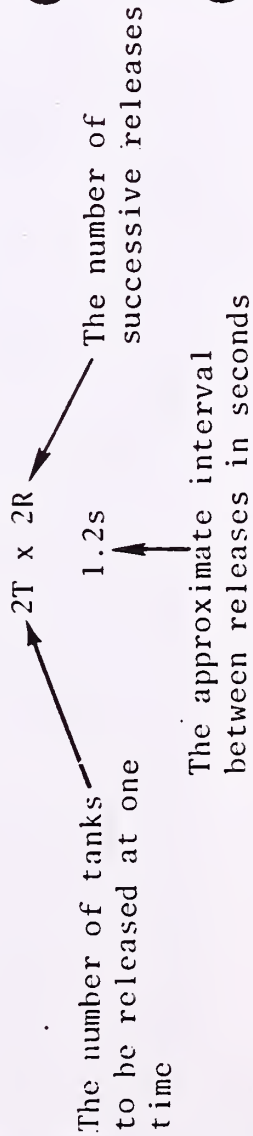

**(G)** NOTE: Avoid use of this strategy close to ground operations under 200-300 feet

**(F)** SAFETY LIMIT--Usually expressed as a fuel clearance distance; will normally be at 150 feet above ground or greater depending on terrain or fuel features.

**(G)** NOTES--Indicate altitude limits for high-momentum drops potentially dangerous to ground personnel when used in close support or call out other recommendations or limitations for a particular strategy.

**(H)** LIMITS OF CAPABILITY--The aircraft cannot produce, in a single pass, line length greater than that defined by the limit curve.

**(I)** REGION OF LIMITED ACCURACY--The ability to place a pattern of the specified coverage level on a spot fire is doubtful if operations must be conducted in this region.

**(J)** OPERATING REGIONS--Most efficient use of the available retardant and pattern controls will occur for the strategy listed. For more precise intervalometer settings see the detailed tables.

**(K)** If the desired drop is well within the linebuilding capability of the release strategy, consider flying higher. This will result in a wider pattern and increase safety.

MAXIMUM LINE LENGTH/TANK-OPENING DELAY TABLES

The Maximum Line Length Tables show, for a selected altitude, the proper delay between tank releases to achieve the maximum coverage over a range of potentially desirable coverage levels.

**(A)** The number of tanks released simultaneously is the basic building block of the pattern. Thus, the value 2 indicates a two-tank salvo. The number of patterns **(B)** tells how many

salvos are delivered. The column entries tell the maximum length of line that can be achieved with reasonable certainty at any coverage level, as well as the correct interval setting **(C)** between salvo releases to achieve this value. These delays are far more precise than those presented in the Best Strategy Charts.

Note that intermediate values can be estimated, if desired, by interpolation between points listed.

(A)	NO. OF TANKS RELEASED AT A TIME	DROP HEIGHT (FT)	NO. OF PATTERNS (B)	LEVEL 1												LEVEL 2												LEVEL 3												LEVEL 4											
				0.5				1.0				2.0				3.0				4.0				6.0																											
				MAX LENGTH (FT)	DELAY (SEC)	MAX LENGTH (FT)	DELAY (SEC)	MAX LENGTH (FT)	DELAY (SEC)	MAX LENGTH (FT)	DELAY (SEC)	MAX LENGTH (FT)	DELAY (SEC)	MAX LENGTH (FT)	DELAY (SEC)	MAX LENGTH (FT)	DELAY (SEC)	MAX LENGTH (FT)	DELAY (SEC)	MAX LENGTH (FT)	DELAY (SEC)																														
	150		1	275	0.0	140	0.0	--	--	--	--	--	--	--	--	--	--	--	--																																
			2	565	1.5	330	1.0	145	0.1	35	0.0	--	--	--	--	--	--	--	--																																
			4	1145	1.5	710	1.0	395	0.7	230	0.0	145	0.2	35	0.0	--	--	--	--																																

All data in the guidelines are presented for two different retardant formulations. The distinction is based on the type of thickening agent, which controls retardant breakup and survival as it falls. The two retardants are:

Δ Gum-thickened--including Phos-Chek XA, Gelgard, and Gum-Thickened Fire-Trol 931 (LC)

Δ Waterlike--including Fire-Trol 100, Fire-Trol 931 (LC), and water

The two categories refer to rheological properties that influence the breakup in the airstream, not fuel-coating or fire-control capabilities, which appear to be similar.

The advantage of the gum-thickened retardant is its tendency to break into larger droplets that provide less surface to evaporate and a higher drop momentum that resists wind deflection. This is shown by comparing the pattern footprints on the following two pages.

That the two types of retardant are equivalent in other respects is supported by the following evidence:

Δ Fuel Surface Coating: Although clay-thickened retardants produce relatively thicker coatings than

COMPARISON OF RETARDANT CAPABILITIES

gum-thickened retardants in dip tests (static conditions), they appear to produce thinner coatings when splashed against the fuel surface (dynamic conditions). Because both conditions contribute to actual fuel coating, the differences might well be offsetting. Observations in the field tend to support this contention in that it is difficult to identify retardant compositions by fuel coverage in areas of similar concentration.

Δ Retardant Effects on the Fire: The active salts of commonly used retardants produce differing effects on certain fires. In terms of effect on spread rates, which is critical to most air-delivery missions, the salt concentration is set to produce equivalent effectiveness. Differences are so minor that a single value of Maximum Useful Concentration applies to both commonly used retardants. (Rothermel, R. C., and C. W. Philpot, "Reducing fire spread in wildland fuels," Northern Forest Fire Laboratory, Missoula, Mont. July 9, 1974).

ALTITUDE EFFECTS ON WATERLIKE RETARDANTS

The accompanying graphs show altitude survival for various coverage levels in a single-tank drop of waterlike retardant. The graphs indicate length of line at any given coverage level. Note that pattern width increases as the retardant falls, until the processes of pattern decay (evaporation losses and overspread) begin to offset the advantages of increasing width. This process yields maximum area coverage at delivery altitudes that are often higher than the lowest safe delivery. In this case the maximum area above 2 gallons per 100 square feet would be expected to occur at about 250 feet.

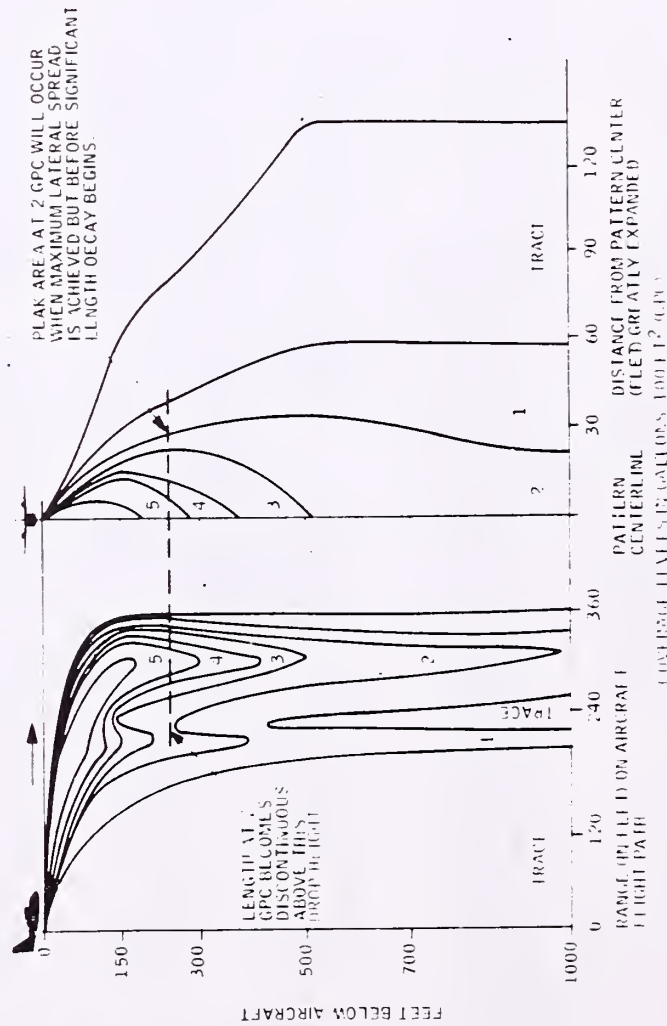

ALTITUDE EFFECTS ON GUM-THICKENED RETARDANTS

Phos-Chek XA exhibits the altitude performance conditions shown in the accompanying graphs. The pattern retains its coherency over a far greater altitude range than for waterlike retardants. This is caused by the formation of larger, more uniform drops that reduce evaporation and diffusion losses as the pattern spreads. In this example, the pattern width reaches a peak at around 250 feet, which also corresponds to the maximum length value.

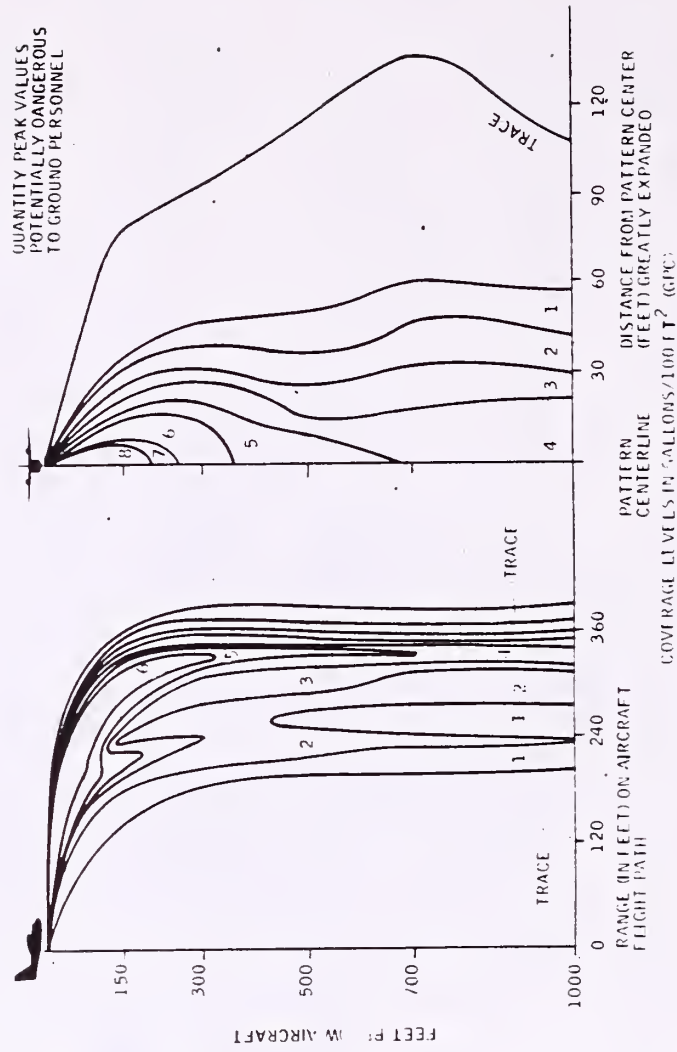

To be effective, a retardant pattern must land where we want it. Some landmark must serve as a target. Some targets are precisely defined--such as the smoke or flame of a spot fire or fuels stained by a prior retardant drop. Other targets are not specific, but are general objectives--the right flank of the fire, for example. In this case, some arbitrary aimpoint must be assumed as the reference for placing the drop. The position of the aimpoint is not the only uncertainty in pattern placement. Others include:

Δ Systematic Uncertainties

- Groundspeed
- Altitude
- Aiming error
- Pilot reaction time
- True line of flight

Λ Tank and Retardant Uncertainties

- Trajectory variability
- Ballistic errors
- Wind
- Equipment response time

Values of these uncertainties, taken from known data or estimates, are tabulated in an error budget.

These uncertainties result in two kinds of inaccuracy:

1. Range Errors--Related to the time of release and aircraft position with respect to the aimpoint along the flight path. It is the distance the pattern lands up- or down-range from the aimpoint.
2. Cross-Range Errors--Related to the distance the pattern lands left or right of the aimpoint.

Range Errors are the most common accuracy problem. Range errors are also easily overcome by generating long patterns.

Cross-Range Errors are smaller than range errors, but we can do little to correct them by manipulation of tanking options. Although the width of the pattern generally increases with altitude, it does not increase as fast as the cross-range error.

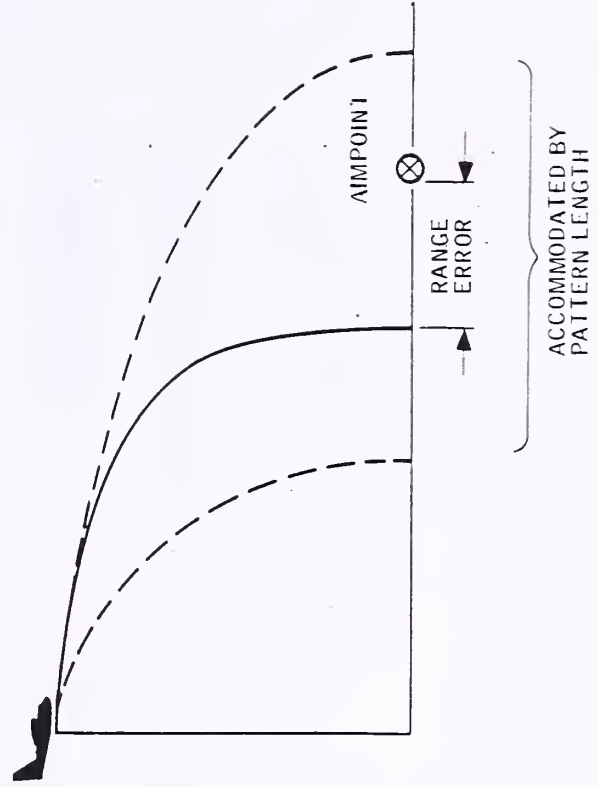
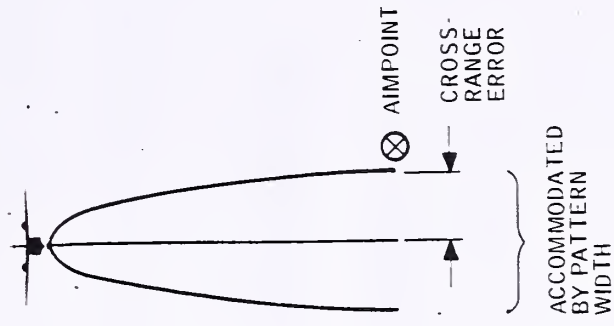

GENERALIZED PROBABILITY OF HIT.

The accuracy of a drop is a function of the pilot's skill, characteristics of the aircraft, and the circumstances related to the drop. Therefore it is not practical to give explicit guidelines on accurate delivery. Aircraft tanking systems can be used to accommodate range errors by increasing line length proportionately. The pilot begins his drop early and prolongs the release to insure hitting the intended aimpoint.

The right-hand figure shows how line length affects probability of hit (PH) under good (low-wind) delivery conditions. A probability of hit of 60 percent is used on the Best Strategy Charts to define regions of limited accuracy.

Accuracy can be enhanced as follows. Whenever possible, fly so that uncertainties are predominantly those of range, which can be overcome by increasing line length. Fly with the wind (or against it), not cross-wind. Second, build the longest continuous line at adequate coverage level from a single aircraft pass rather than attempt to connect patterns from separate deliveries. Third, use similar retardant and drop missions repeatedly, allowing the pilot to develop experience in judging his drop trajectory.

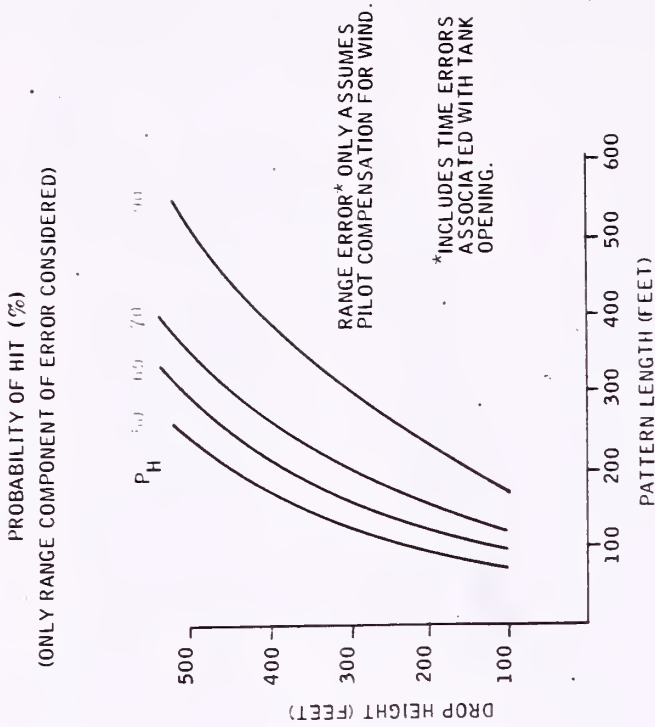

NOTES ON COVERAGE OF GROUND FUELS

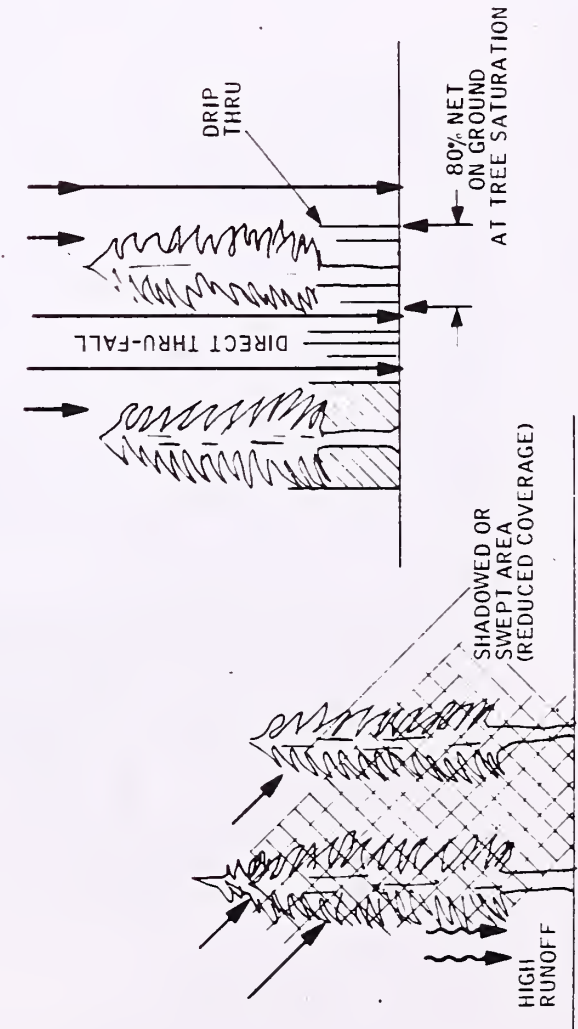

Flight options for adequately covering fuels beneath an overstory are:

- Δ Delivery in horizontal flight from relatively high altitudes which takes advantage of the vertical openness of most stands.
  - Δ Attempts to drive the retardant through the overstory by low-level or dive attack.
- Near-vertical fall of the retardant usually yields the most uniform and consequently most efficient retardant distribution, particularly in open areas. The overstory shields certain areas as the angle of entry is increased. Drip-through prolongs the application time (about 10 minutes) which can be a benefit.





