

T

353

S8



Class T 353

Book 58

Copyright N^o _____

COPYRIGHT DEPOSIT.

NOTES
ON
MECHANICAL DRAWING
GRAPHIC STATICS
MACHINE DESIGN, and
KINEMATICS

BY

L. CHESTON STARKEY, M.E.

Professor of Mechanical Engineering
Drexel Institute, Philadelphia

PHILADELPHIA
PUBLISHED BY THE AUTHOR
1909

T 353 88

Copyright 1909
by
L. Cheston Starkey



Printed by
Benjamin F. Emery
Philadelphia

© Cl. A 253882

orig. Jan. 12, 1910

CONTENTS

PART I. MECHANICAL DRAWING.

NOTES AND GENERAL INSTRUCTIONS	7
Preliminary Drawings—Drawing Boards and T Square—Triangles—Pencils—Pens—Scale and Measuring—Use of Tracing Cloth—Size of Plates—Drawings—Dimensions—Shading—Hatching.	
SCREW THREADS	13
Various Kinds—Conventional Method of Representing Screw-Threads.	
ISOMETRIC DRAWING	15
Freehand Isometric Sketches.	
INTERSECTIONS AND DEVELOPMENTS	17
Details and Assemblies—Original Designs.	
NOTES ON GEARING	18
Gear Curves—Definitions—Exact Construction of Gear Curves—Approximate Methods of Constructing Gear Curves.	
SCHEDULE OF PLATES	21
Suggestions Concerning These Plates.	

PART II. GRAPHIC STATICS.

A—ELEMENTARY GRAPHICAL STATICS	27
SOME FUNDAMENTAL DEFINITIONS AND SUGGESTIONS	28
Force—Resultant—Scalar Quantities—Vector Quantities—Force Polygon.	
APPLICATION OF PRECEDING DEFINITIONS AND PRINCIPLES.....	29
GENERAL SUGGESTIONS AND HELPS FOR SOLVING A PROBLEM BY GRAPHICAL METHOD	33
Case A—Case B—Application of above Rules to Solution of Fig. 22.	
DATA FOR THE VARIOUS PLATES IN GRAPHICS	33
Method of Determining Whether Members are in Tension or Compression.	
SUPPLEMENT PROBLEMS	41
B—GRAPHICAL STATICS OF MECHANISMS	42
Friction—Angle of Friction—Efficiency—Useful Suggestions.	
SUGGESTIONS AND QUESTIONS FOR VARIOUS PLATES	45
Plate I—Journal Friction—Plate II—Tooth Friction—Theory of Tooth Friction—Plate III—Plate IV—Belt Resultant—Plate V—Plate VI—Graphical Constructions.	
SUPPLEMENT PROBLEMS	54

PART III. MACHINE DESIGN.

MACHINE DESIGN	57
Kinematics—Graphical Statics—Machine Design—Theory vs. Practice in Design—Hand-Books and Empirical Data—Notes and Calculations—Power Transmission.	
BELTS AND PULLEYS	62
Other Kinds of Belting—Theory of Belting—Values of f —Strength of Leather Belting—Speed and Horse-Power of Belts—Notes and Data for Prob. 8.	
NOTES ON GEARING	70
Definitions—Methods of Constructing Cycloidal and Involute Teeth—Prob. 10, Design of a Spur Gear—Suggestions—Prob. 13, Design of a Bevel Gear—Design of a Worm Gear—Design of a Connecting Rod—Supplement Problems.	
SPECIAL PROBLEMS	90

PART IV. KINEMATICS.

FUNDAMENTAL DEFINITIONS AND CONCEPTIONS	97
Motion—Relative and Absolute Motion—Constrained Motion—Machine—Mechanism—Link—Chain—Constrained Chain—Pair of Machine Elements.	
INVERSIONS OF MECHANISMS	99
INSTANTANEOUS CENTERS	100
PROBLEMS IN INSTANTANEOUS CENTERS AND DISPLACEMENTS	102
A MORE GENERAL DISCUSSION OF INSTANTANEOUS CENTERS	105
New Definition of Instantaneous Centers—Method of Locating Instantaneous Centers—Theorem of Three Centers—Proof of the Theorem—Relation Between Angular Velocities of Any Three Pieces.	
CENTRODE CONSTRUCTION	109
CENTER OF ACCELERATION	110
CAM DESIGN	110
Definitions—Graphical Method of Laying off Harmonic Motion and Uniformly Accelerated Motion.	
PROOF OF CYCLOIDAL AND INVOLUTE CURVES	114
Cycloidal—Involute.	
DERIVATION OF BELT FORMULA	116

PREFACE

The author has often felt that one of the weak points in many educational courses, particularly in Engineering, lies in the lack of correlation and cohesion of the various studies. In the commendable zeal with which a particular subject is elaborated, sight is often lost of its relative importance, its relation to other subjects, and its position in the general scheme; to the very great detriment of the student.

His time and energies have been so engrossed and concentrated on each subject that eventually he finds his mind stored with an array of hazy and sometimes almost contradictory facts, that are difficult to remember or apply simply because they were never tied together properly nor their inter-relations made clear. Largely for that reason, the attempt is here made to take four closely connected branches of study, any one of which by itself could well be, and usually is, made the basis of an entire volume; and to present them together under one cover in order that time may be saved in avoiding a certain amount of repetition which always occurs when they are taken up separately, and especially that the student may see each in its true relation to the others, have his interest aroused thereby, and his work made pleasanter, and more profitable.

Necessarily the treatment is very much abridged. In some instances, only the more fundamental principles are given, but in every case the application of theory to practice is exemplified in numerous problems.

The questions asked in connection with many of the problems will be found especially useful in emphasizing important points, and in causing the student to do some thinking and reasoning on his own account. A few of the problems and illustrations were taken from other books, for which due acknowledgement is made.

The author is especially indebted to Prof. J. F. Klein, of Lehigh University, for permission to use many of his illustrations in Machine Design and Graphical Statics of Mechanism, and for many other valuable suggestions and ideas.

No attempt is made to claim that this book is in itself a satisfactory or complete treatment of any of the four subjects contained therein. The student should have available for use or reference one

or more of the many good, standard text-books that have been written on each of these various topics. The aim throughout has been to select the important points, make those few points as clear as possible so as to be thoroughly understood; and then by the proper correlation, give the student a broad view and a good intelligent grasp of the entire matter.

Drexel Institute, Philadelphia,
August 12, 1909.

PART I

MECHANICAL DRAWING

NOTES AND GENERAL INSTRUCTIONS

In the following notes and suggestions only the more general ideas are given, as it would be unwise to take up space in the attempt to give a complete set of rules for the guidance of the beginner in mechanical drawing. Many of the finer points which characterize the work of a finished draftsman will come naturally in the course of experience; other helpful suggestions will have to be obtained from the instructor, while many valuable little time-saving ideas connected with the use of a draftsman's outfit may be picked up casually while watching fellow-draftsmen at their work.

Preliminary Drawings. Drawings should first be done accurately in lead pencil and dimensioned completely before attempting to ink in. Before inking is the time also to examine the drawing carefully for any mistakes; and in all cases, the instructor's approval should be obtained before proceeding. A little extra time spent here is very well invested because in this lead pencil state corrections can be made at the expense of very little time and trouble; which, if overlooked until the drawing is inked, means the loss of a great deal of time and trouble, very likely an unsatisfactory job; and, in many cases, an entire redrawing. Be sure to make the lead pencil drawing accurate especially the fillets. Don't make the mistake of thinking you will correct a careless lead pencil drawing when you go over it to ink in.

Drawing Boards and T-Square. Only one edge of the drawing-board needs to be made a true straight line. This is the working edge, and when in use is to be the left side. The

head of the T-square is to slide along this edge only, and must be kept pressed against the working edge with the left hand when in use. Use the T-square in drawing horizontal lines. Use only the top edge of the T-square. Never use the T-square in trimming a drawing.

Triangles. All vertical and slant lines are drawn with the triangles. With the aid of the T-square, a 45° , and a 30° — 60° triangle; angles of 15° , 30° , 45° , 60° , 75° and 90° may readily be drawn. Keep the triangles clean.

Pencils. For sketching, use a medium pencil. For making finished drawings do not use a pencil softer than 6H. Provide two pencils, a 6H and 8H. Sharpen the 6H to a chisel point and the 8H to a round needle point. Pencils should always be sharpened on end opposite to the number.

The leads for compasses must not be softer than 8H. The point of a compass lead should be the shape of a round pointed chisel and set so the flat will be tangent to the drawn circle.

Pens. The ruling pen requires most careful and patient manipulation. After the pen is filled, care should be taken that no ink is on the outside of the nibs, and that the guiding straight edge does not come in contact with the inked line. Press the pen only lightly against the straight edge. If the ink does not flow freely, draw the pen quickly across the penwiper; then if the ink fails to flow, clean out and refill the pen. Always thoroughly clean out the pen when through with it.

Be sure of the thickness of the line, try the pen on a piece of paper of the same kind as is being used for the drawing.

When inking a drawing, always ink in the circles and curves first; then the straight lines. It is usually quicker and more convenient to ink in all the lines in one direction at one time. If, after inking in a circle or curve, it is found to be indistinct, go over it again in the same direction, never in the reverse.

Fillets should always be inked in with the bow pen. Be sure the width of the fillet line is the same as the lines it joins.

Horizontal and slant lines should be drawn from left to

right; vertical lines, from bottom to top; in general, draw from, not toward you.

Scale and Measuring. Use a triangular scale and remember that it was never intended for a ruler or straight edge, or to be used for any other purpose than to measure distances. The method of measuring by placing dividers on the scale is convenient but ruinous to the scale. A flat 12" steel scale is very useful and very durable.

When a drawing is made to a reduced size, the full size scale should not be used by dividing the divisions; but by using the particular scale which is arranged and adapted for the purpose. For example—A drawing may be made one-fourth size (or its equivalent, three inches to the foot) which indicates that a graduation is to be found where every three inches is marked as a foot, and also one of these three-inch lengths is sub-divided into twelve equal parts which are the inches to the reduced scale.

In making drawings of details it is always advisable to draw them to as large a scale as can be used conveniently. The scales commonly used for small details are full size; and for larger ones 6 inches, 3 inches, or $1\frac{1}{2}$ inches = one foot may be used. This corresponds to full size, half size, quarter size, one-eighth size, etc., which agrees with the fractional dimensions usually employed, viz.:— $\frac{1}{2}$ ", $\frac{1}{4}$ ", $\frac{1}{8}$ " and $\frac{1}{16}$ ". A scale of 4 inches or 2 inches = one foot should never be used if it can possibly be avoided, for the same reason that the fractional dimensions $\frac{1}{3}$ ", $\frac{1}{5}$ ", $\frac{1}{6}$ ", etc., should not be employed.

Use of Tracing Cloth. Before tracing cloth or linen is placed on the board, tear off the wrinkled edge. Use preferably the dull side of the cloth, though either side may be used to draw on. Before using the tracing cloth the surface should be rubbed with chalk-dust, pounce, or talc.

Tracing-cloth is very susceptible to atmospheric moisture and may become tight or loose; hence each view should be finished if possible before going to the next, or at least by the end of the day's work.

Do not allow a drop of water to get on the cloth.

Tracings may be cleaned with gasoline or benzine. Ink may be erased with a sharp knife, or an ink eraser and shield,

but all the glazing should not be removed down to the cloth. Before inking again, rub the erased spot with a piece of soapstone, a bone, or the finger nail.

Size of Plates: The standard size of drawings will be 18" x 24". A half sheet will be 12" x 18" and a quarter sheet 9" x 12". On all sizes of plates draw a border line one-half inch from each edge. Do not put in fancy corners.

Drawings. After determining the size of the sheet and the scale to which the drawings are to be made, estimate approximately the positions of the different views on the sheet. Reserve a space in the lower right corner for the title stamp about 3" x 2".

Arrange the views in their natural order; that is—from the elevation or front view, show the plan or top view on top, and the view of the right side at the right, etc. It pays to spend a little time estimating and planning how the views are to be placed and how much space they will require. Never go ahead blindly and place the front view of an object at random on the sheet of paper, trusting to luck for space enough for the other views.

For the standard style of lettering and the different kinds of lines to be used, see accompanying Instruction Plate No. 1.

Dimensions. The arrow-heads for dimensioning are to be slender with points touching the lines between which the dimension is given. The dimensions are usually placed midway between the arrowheads, except when several dimensions would come directly under each other, then they are staggered.

Dimensions should always be placed so as to read either from the bottom or the right-hand edge of the drawing. The arrow-heads and dimensions of circles should be in the first and third quadrant. Dimension a circle by the diameter in preference to the radius, but designate which by a "Dia" or "Rad". No arrow-points are used at the center of a circle.

Dimensions up to and including two feet are to be given in inches: thus 15", 18", 24"; over two feet, in feet and inches; thus 2'-4", 3'-10".

There is no fixed rule for this. In some places, only dimensions above three feet are given in feet and inches. For the sake of uniformity however, use the two feet limit.

Give "overall" dimensions. Put in too many rather than

not enough dimensions. Do not leave it to the workmen to figure out anything.

It is often found that students are rather careless and, in many cases, apparently helpless about deciding when enough dimensions are down. There is no reason why, with a little practice, this could not be entirely overcome. All that is necessary is for the student to imagine he is now himself going to **make** that which he has drawn, and then proceed in his imagination to construct it, and the lack of dimensions will soon become apparent.

Unless extreme accuracy is required, decimal dimensions are not employed. In any design or calculation, if the results come out a decimal, change the result to the next larger 8th, 16th, or 32d of an inch, according to the accuracy required. Of course, there are certain cases where a decimal dimension is unavoidable, as the diameter of a bolt at the root of the threads, or the long diameter of a hexagonal nut when the distance between the flats is an exact fractional dimension, or in gear teeth.

The question of where to place dimensions is largely a matter of judgment and experience. No positive rules can be given. In general extension lines should be used and the dimensions placed outside the view to avoid any possibility of confusion; but on the other hand, if the view is rather open and free from lines, place the dimensions inside the view between the actual lines whose distance apart it is desired to represent.

The three examples shown at the bottom of Instruction Plate No. 2, represent the ways of dimensioning when the distances are small.

In cases where there is room for both arrow and dimensions, use method shown by (a); where the lines are so close that there is not room for both arrows and dimensions, use method shown by (b); and in cases where the lines are very close together, use method shown by (c).

On all drawings place a small "f" on all surfaces to be finished; and state also in a conspicuous place on the drawing what "f" stands for; thus, "f"=FINISH.

Shading: Concerning the advisability of shading a mechanical drawing, there is considerable difference of opinion.

In some drafting rooms it is considered a waste of time and is never used, while in other places it is absolutely insisted upon.

To be on the safe side a student should know how to shade a drawing; then he is prepared for both conditions. The idea in shading is to consider that the light comes down on the drawing board from the upper left hand corner and then shade those edges which separate a light from a dark surface. The application of this leads to the two following pretty general rules: **First:**—Shade the bottom and right hand edges of all solid objects. **Second:**—Shade the upper and left hand edges of all holes or hollows. Students will use these two rules in their work with the exception of the case of curved surfaces as a cylinder, where the method to be used will be shown by instructor. The method of shading a circle is shown by Fig. 1 on Instruction Plate No. 2. The arc is struck from the second center as shown, with same radius as that of the circle: then the space between the two curves is filled in carefully by gradually shortening the radius but keeping the point of the compass in the second center.

If the circle represents a hole, the other half of the circle is shaded instead and by the same method. Shading makes a drawing easier to read.

Hatching, or cross-hatching as it is sometimes called, is used to represent surfaces that have been cut through in a section view. The various styles of hatching for different materials are shown on Instruction Plate No. 2. All these section lines have a slant of 45° , except the one for the white metals such as lead, babbitt, etc.; these lines are usually made 60° . A common difficulty in cross-hatching is to space the section lines a uniform distance apart; then again many students space uniformly, but get the lines entirely too close together; while others place them too far apart. The samples shown in the Instruction Plate give about the correct distance which in most cases should be $1/16''$ to $3/32''$.

Fig. 2 of Instruction Plate No. 2 shows a conventional method of representing the broken ends of a shaft or other cylindrical body when for convenience in saving space on the drawing, the middle portion of the cylinder is removed.

SCREW-THREADS.

Various Kinds. The common systems of screw threads are the Sharp V-thread for pipe fittings, the Sellers or U. S. Standard, the Whitworth or English thread, the Square thread and the 15° (really $14\frac{1}{2}^\circ$) or Acme thread. These various threads are shown on Instruction Plate No. 3.

The first three mentioned threads are generally used for fastenings, while the last two are used for transmitting motion, since there is less friction between the bolt-thread and the nut than with the first three. A right hand thread is one in which a clock-wise rotation of the nut causes it to advance further on the bolt; while a left hand thread is one in which a clock-wise rotation of nut will cause it to work off the bolt.

The Sharp V-thread is cut by means of pipe taps and dies; the die cutting a male thread, and the tap, a female thread. Male threads are threads cut on the outside, as on a bolt; female threads are threads cut on the inside as in a nut. Pipe-threads are always cut tapering which thus makes a tight fit where couplings are made and also makes the thread easier to start when erecting pipe lines and making connections.

In all five samples of threads shown, p =pitch of thread, and d =depth of thread.

The U. S. Standard, as shown in the cut, is truncated both top and bottom an amount = $1/8$ of original depth of thread. This makes the thread easier to cut on a lathe, and eliminates the danger of sharp corners breaking off and consequent jamming of thread and nut.

The Whitworth or English Standard is rounded off top and bottom an amount = $1/6$ of original depth of thread and is a 55° angle thread, whereas the U. S. thread is a 60° angle as shown.

The Square thread and Acme thread are constructed and proportioned as indicated. They are both well adapted for transmitting motion, the Acme thread being especially useful in disengaging nut from thread as in the split nut on the lead screw of a lathe.

Conventional Method of Representing Screw-Threads. Usually a mechanical drawing is made just exactly as the object looks; but to do this in the case of screw threads would

involve a great deal of unnecessary time and trouble; hence various conventional methods of representing them have been universally adopted; and are shown on Instruction Plate No. 3.

Fig. 3 represents a very neat and simple way of indicating a thread that seems to be growing in favor; although in carefully finished drawings, its use is generally restricted to those bolts and threads which, when laid out on the drawing, are 1" or less in diameter. In Figs. 3 to 8, D =diameter of bolt.

Fig. 4 represents a conventional method much used especially for the larger size of U. S. Standard threads. It will be noticed that Fig. 4 shows a right hand, single pitch thread. A **single pitch** thread being one in which there is only one continuous thread cut on the cylindrical bolt body; while on a **double pitch** thread or screw there are two separate threads cut. Student will note the following special features: (a) slant of thread from left to right; (b) relative position of the V's on opposite side of the bolt—V on the right being just **one half** a space higher than the one on the left; (c) short slant lines usually made shade lines and not exactly parallel to the longer slant lines connecting the tops of the thread; (d) continuing any thread such as ab , around on the other side of the bolt and giving it the same slant in the opposite direction as shown by dotted line bc brings the points a and c just one thread's distance apart, thus showing it to be a single pitch thread, as compared with same process in Fig. 5 which brings distance between a and c equal to two threads and thus gives the conventional representation of a double pitch thread.

Fig. 5, as already indicated, is a double-pitch left-hand thread. Student will note carefully the same special features of construction as outlined for Fig. 4 (corresponding V's are one whole space higher).

Fig. 6, is a still more exact method of representing conventionally a single-pitch right-hand thread, bringing out the truncated effect of threads. This truncation is sometimes shown at tops of thread by double slant lines there also. However, this method of Fig. 6 is much more difficult for the draftsman and is only used in exceptional work. It is understood in Figs. 4 and 5 that threads are to be truncated.

Figs. 7 and 8 represent the conventional way of showing right-hand single-pitch and double-pitch square threads respectively. Note again, as in preceding figures, the slant of lines *ab* and *bc*, and the number of threads between *a* and *c* in each figure.

Fig. 9 shows the exact construction of a true helix or square thread and gives an idea of the tremendous amount of labor involved if all threads were drawn exactly as they appear.

The Figure is intended to be self-explanatory. Remembering that as a thread revolves or is cut around the body of a bolt it advances **uniformly** parallel to the axis of the bolt, the student should have very little trouble in following the reasoning which divides the end view or circle up into 12 equal parts, and then divides the pitch into 12 equal parts and gets the various points in the helix by the intersection of the corresponding lines as shown. In the drawing of this helix by the student at least **four** full threads should be shown; and part of the benefit of the problem lies in the practice afforded the draftsman in drawing this rather difficult curve, as well as the principles of construction involved.

ISOMETRIC DRAWING.

This is a branch of mechanical drawing which enables one to represent an object in such a manner as to present three sides, or faces, in a single drawing or view. That is, such a drawing serves the same purpose as an ordinary three-view mechanical drawing; and furthermore, leaving out the perspective effect, it pictures the object as it would appear if placed before the observer in a certain position; and because of this characteristic is easily read and understood. Thus, it has the double advantage of showing clearly what the object represented really looks like; and at the same time being drawn accurately to scale, it is a working drawing from which, if necessary, models may be made in the shops.

The three axes, shown in Fig. 10, Instruction Plate No. 4, are called the isometric axes and are 120 degrees apart, as shown. These form the basis of all isometric drawings, and the three planes determined by these axes are called the isometric planes.

In all curved work, the curve is first laid out on a trial sheet of paper as if it were an ordinary mechanical drawing; and a succession of points being taken on this curve, co-ordinate lines are drawn to an enclosing rectangle; then an isometric rectangle is laid off to the same scale and dimensioned, and divided up into the same co-ordinate lines as the former; and a curve, plotted through the intersections of these co-ordinates, will give the desired isometric curve. This construction, however, is not necessary in the case of a circle, as will be explained in class.

The work in this course will consist of six freehand sketches of simple objects on the special isometric paper; and one carefully drawn isometric of some machine part which will be assigned, this drawing to be inked in and a tracing made.

Freehand Isometric Sketches: These sketches must be done **freehand** on the specially prepared isometric sheets and fastened into a little folio or book shape before handing in.

I. Make an isometric sketch full size of a 3" cube with a circle inscribed in each of the three visible faces.

II. Isometric of a 3" cube having a 2" round hole through its vertical center and one quadrant removed. Make the removed quadrant the front quadrant in the isometric sketch.

III. Isometric of hexagonal nut for a standard $1\frac{3}{4}$ " bolt, using standard dimensions. (See Kent.)

IV. Isometric of object to be given you at proper time.

V. Isometric of a hexagonal pyramid, base 1" on a side and height 5", pyramid to be lying down with axis horizontal and apex to the right.

VI. Isometric of object to be given you at proper time.

VII. Isometric of a hollow 2" cube, open top and bottom, with sides $\frac{1}{4}$ " thick, pierced horizontally through the center by a cylindrical rod 1" diameter and 5" long.

VIII. Isometric of a hexagonal prism 1" on a side and 4" high placed vertical and with one edge toward you, pierced horizontally through the center by a triangular prism $1\frac{1}{4}$ " on a side and 5" long.

NOTE: Student will make six of these sketches in lead pencil, as directed by instructor; and then a finished isometric of some machine part as above indicated.

INTERSECTIONS AND DEVELOPMENTS.

The curves of intersection of cones, cylinders, etc., are readily drawn by keeping in mind the fact that all of these curved surfaces are made up of successive positions of straight line elements. The same thing is true of the development of their surfaces.

Fig. 11 illustrates the method of obtaining the curve of intersection of any plane, MN with a cone. The student should examine carefully the method herein outlined until he understands the principles used. **Method:** The front view shows the cutting plane: what is wanted is the curve of intersection as shown in side view. On the base line of the front view draw a semi-circle, representing half of the bottom view of the cone; divide this semi-circle into a convenient number of equal divisions, 12, 23, 34, etc. (Note that it is not absolutely necessary that they should be equal but it is more convenient to have them so.) Project these points up on the base line and get the corresponding points there, then draw the various elements from the apex of the cone, viz.: o1, o2, o3, o4, etc., noting their points of intersection with plane MN at d, c, b and a. Now referring to the side view of the cone, it is evident that the extreme right edge element o1 of the front view becomes the middle element of the side view and is so designated. To locate the other elements construct a semi-circle on the side view just as on the front view; divide semi-circle into the same number of equal parts and project up to the base line, thus locating the correct position of the elements o2, o3, o4, etc., in the side view. (Student should stop and go over this point until he sees it clearly.) All that is needed now is to project over from d, c, b and a until the projected line intersects the corresponding element in side view; thus a is where plane MN cuts element o4 in front view, then project over horizontally from a until the line intersects element o4 in side view which it does at a'. Thus, the various points a', b', c' and d' are located, and of course there are symmetrical points on the other side of the center line and hence the complete curve is obtained as indicated on the figure.

The lower half of Instruction Plate No. 4 gives the data

for Plate IX, which is a plate of intersections and also gives a suggestion as to the proper arrangement of the different views so as to use the paper to the best advantage and produce a nicely balanced sheet, as far as filling up the space is concerned.

As a general thing, in regard to intersections and developments, the length of any particular element can be obtained from the front view, while the exact location of the particular element may be obtained from the end view.

The object of the problems is to train the student to understand why they are done in a particular way, as well as how they are done. Very little good is obtained from drawing these curves without understanding the principles involved. Consult the instructor freely on these plates.

Details and Assemblies: The student should have considerable practice in drawing details from assembly views, and also in making the finished assembly drawing by combining the details. The object sought in mechanical drawing is the ability to read, as well as to make working drawings and blue prints; and the detail and assembly work is particularly useful in developing the ability to read drawings.

Original Designs: In many cases, the ability to think out original designs and ideas will be needed, and a student should possess some originality in design as well as the ability to make and read drawings. For that reason, one or more simple original designs should be required.

NOTES ON GEARING.

Gearing is used to transmit rotation or motion from one shaft to another. The shafts so connected may be parallel or inclined to each other, their axes may or may not intersect; but the most common form is the one in which the axes of the two connected shafts are parallel and lie in the same plane; and the name applied to that case is spur gears. Gears have teeth formed on their rim of such a shape as to intermesh with the similar teeth on the mating gear and transmit a perfectly uniform angular motion. The design and construction of gear teeth so that they will do their work properly is a very important matter, and it is evident that the curve suitable for a tooth profile must possess certain special properties.

Gear Curves: There are two such curves now in use, the **cycloidal** and the **involute**. The former curve was more generally used at first; but at the present time the involute type of tooth is much more common.

A draftsman should be familiar with the nature of these two curves and also with some approximate method of constructing them readily.

Definitions: A **cycloid** is a curve traced by a point in the circumference of a circle as it rolls along a plane curve. An **involute** of a plane curve is the point traced by the end of a taut string or cord as it is unwound from the plane curve.

In subsequent work, the proof that these curves possess the qualities necessary for a gear tooth profile will be established; at present the student will need to know what they are and how to construct them.

Exact Construction of Gear Curves: The construction of cycloidal and involute curves by the exact method is easily done. Student should be able to draw either of these curves without much assistance especially in the case where the base curve is a circle. When a small circle rolls on the outside of another circle, the curve traced by a point in the circumference of the rolling circle is called an **epicycloid**; when rolling on the inside, it is called a **hypocycloid**. In each of these cases, all that is necessary is for the draftsman to roll the circle into new positions and note the path traced by the point in its circumference.

Fig. 12 illustrates the method of plotting an exact hypocycloid. Positions marked 1, 2, 3, 4, etc., represent successive positions of the describing circle as it rolls along the large circle whose radius is marked R in the Figure; the problem being to determine the path of any point, say p , in the rolling circle. It seems best to allow the student to solve this himself with the aid of figure as shown. A small portion of the cycloidal curve is shown shaded in the Figure. There are various ways of constructing this exact curve; and one especially very good one which does not necessitate drawing the rolling circle, or even a portion of it, for each new position. Of course, the circle of centers shown in the Figure is merely a convenience for locating the new positions of the rolling or describing circle.

Fig. 13 shows shaded a small portion of an involute curve. The end of the string is at E and as it unwinds, being held taut during the operation, the end E describes the path shown. The method to be followed is partly indicated; and the student is left to his own resources. Lines fM, gN, hT are construction lines necessary in determining the path.

Both of these exact methods however involve a laborious process and in actual gear teeth construction only such a small portion of the cycloidal or involute curve is used in forming the tooth profile; that an approximation to the exact shape of these curves can easily be made by means of circular arcs. The curves thus formed are so nearly identical with the actual ones as to work satisfactorily and answer all practical purposes; besides of course being much more easily and quickly made.

Approximate Methods of Constructing Gear Curves:

There are a number of approximate methods of constructing either of these two gear curves. One method of constructing a cycloidal tooth is shown in Fig. 14, Instruction Plate No. 5. The radii of the pitch circle and the describing circles are assumed. The diameters fg and ht of the describing circles are then drawn making an angle of 30° with the line of centers. Line mn is drawn through the pitch point p and through the points f and h. As a check it ought to make a 75° angle with the center line. Radial lines are now drawn from center of pitch circle through the points t and g intersecting the mn line at b and c. With b as a center and bh as a radius, strike an arc through h, and this is the hypocycloid or flank of the tooth; then with c as a center and cf as a radius strike an arc through f forming the epicycloid or face of the tooth. Now to bring these two curves together at a common point and form the entire tooth profile, use is made of the circles of centers. A little reflection will show that circles through b and c will contain the centers of all the arcs that may be used as portions of flank and face of tooth respectively. Thus to draw a complete tooth profile through any point, say the pitch point p, set the compasses at a radius bh and move back along the circle of centers to point b', and describe the flank of the tooth through p. Then set the compasses to a radius cf and move back along the lower circle

of centers to c' , and describe the face of the tooth through p , forming the shaded curve as shown. By a similar method teeth can be formed at any desired point on the circumference of the pitch circle.

The tooth is limited at the top by the addendum circle, whose distance from the pitch circle varies with different gear makers; but the average value of which may be taken as .3 circular pitch. At the bottom the tooth is limited by the root circle the average value of whose distance from the pitch circle is about .4 circular pitch. Thus it is seen that in any case only a small portion of the cycloidal or involute curve is used as a gear tooth profile, the wheel being made up of a succession of these curves. Thickness of tooth at pitch point depends somewhat upon whether teeth are cast or whether they are cut. In the latter case very little clearance is given. Student may take thickness equal to .48 circular pitch.

An approximate method of constructing an involute tooth is shown in Fig. 15. The pitch circle is drawn with a known radius. Through the pitch point the base line MN is drawn making an angle of 75° with the center line as shown.

The base circle is then drawn tangent to this base line, point of tangency falling at T . Measure up along the center line a distance pb equal to one-tenth the circular pitch; and through b draw a tangent to base circle, point of tangency falling at d ; measure back along db a distance od equal one-fourth db ; and with o as a center and ob as a radius describe the approximate involute curve through b . Note that this curve should be limited at the top by the addendum circle and at the bottom by the base circle; from the base circle to root circle the profile of tooth is a portion of a radial line as indicated. By drawing a circle of centers through o , and proceeding as indicated in Fig. 14, the involute tooth can be constructed at any desired point in the circumference of the pitch circle.

SCHEDULE OF PLATES.

The following schedule of drawing plates is suggested as a basis for the year's work:—

Plate I. Drawing directly from models of joinery

exercise in the wood-shop. Make at least 3 views. First make a free-hand sketch of various views of object and dimension fully; then use only this sketch to work from.

- Plate II. Same as Plate I. using a more difficult object.
- Plate III. Same as Plate II. using an iron casting.
- Plate IV. Plate of different kinds of screw threads.
- Plate V. Same as Plate III. selecting a more difficult object.
- Plate VI. Same as Plate III. using a connecting rod.
- Plate VII. Problems in Isometric (free-hand sketches).
- Plate VIII. Isometric of connecting rod (finished drawing).
- Plate IX. Intersections (see Instruction Plate No. 4).
- Plate X. Developments (see Instruction Plate No. 5).
- Plate XI. Tracing of Plate VIII.
- Plate XII. Details and assembly. Make tracings and blue prints.
- Plate XIII. Same as XII.
- Plate XIV. One or more problems in original design.
- Plate XV. Design of a gear.

Suggestions Concerning These Plates: All drawings must be finished in ink except Plate VII. and must be shaded. In the first three plates, students should make their free-hand sketch complete so that it will not be necessary to refer to the original object when making the finished drawing. This will be very helpful in teaching what are the necessary dimensions on a drawing.

Plate I is made very simple and easy for the sake of the beginner in the use of instruments; but special care should be given to proper arrangement of views and method of placing dimensions. In Plate II, one or two geometric exercises should also be included, such as an approximate method for constructing an ellipse, etc. Plate III, should include a section view. In Plate IV, actual examples of bolts, screw threads, etc., should be used to draw from; and the Plate should include one exact construction of a square helix or thread (see Instruction Plate No. 3.) In Plate VI, pay careful atten-

tion to the way parts are fastened together and to provision for taking up wear. Data for Plate X. is on upper half of Instruction Plate No. 5.

Plate XV: The work of this plate will consist of three parts:—

- (a) Construction of a cycloidal and involute curve by exact method.
- (b) Construction of a cycloidal and involute curve by approximate method.
- (c) Design of a spur gear, including 2 views, one being a section view. A full set of calculations to be worked up and neatly tabulated in ink to accompany the (c) part of this plate.

NOTE: Arrange the three parts or problems in such a way that they will not crowd each other on the plate. Some careful preliminary planning may be necessary to secure this.

Data for Plate XV: (a) Roll a 1" circle on a portion of a 12" circle and show the epicycloidal curve for one complete rotation of rolling circle. Unwind a taut string from an 8" circle showing about 1" of the involute curve thus made. In both of these exercises place on the views explanation and markings sufficient to show exactly how you proceeded.

(b) For cycloidal curve, radius of pitch circle = _____, circular pitch or (p') = _____, radius of rolling circle = _____. Draw one complete tooth and dimension it. For involute curve, radius of pitch circle = _____, circular pitch = _____. Draw one complete tooth and dimension it.

(c) Two parallel shafts _____ apart are to be connected by a pair of spur gears. One shaft makes _____ r. p. m. and the other is to make _____ r. p. m. and _____ hp. is to be transmitted; use _____ teeth.

Design the larger gear wheel and provide the gear with 4 elliptical arms. Make your calculations neatly and systematically, tabulating both the work and the results in the following order, using these symbols:—

1. D = diameter of large gear.
2. d = diameter of small gear.
3. R = radius of large gear.
4. r = radius of small gear.
5. H = horse power transmitted.

6. $N = r. p. m.$ of large gear.
7. $W =$ force exerted on teeth of gear at pitch point.
8. $s =$ allowable stress in teeth (assume $= 4000$ lbs. per sq. in.)
9. $p' =$ circular pitch of teeth.
10. $p =$ diametral pitch of teeth.
11. $f =$ width of teeth.
12. $t =$ thickness of teeth at pitch circle.
13. $a =$ thickness of rim of wheel.
14. $b =$ imaginary width of arms at center of shaft.
15. $c =$ thickness of arms.
16. $e =$ diameter of shaft.
17. $g =$ thickness of hub.
18. $m =$ width of key.
19. $n =$ thickness of key.
20. $u =$ length of hub.
21. $y =$ number of arms.

SUGGESTIONS: The first six values are either given by, or worked out directly from, the data. To obtain W note that force exerted at pitch point multiplied by distance it is overcome in one revolution gives the number of foot pounds of work in one revolution; and from the given values of H , N and D , the value of W can therefore be readily computed.

Circular pitch $=$ distance from one tooth to the corresponding point on next measured along the pitch circle. Diametral pitch $=$ number of teeth per inch of diameter and hence

$$p = \pi \div p' \quad (1).$$

The width of teeth vary from 2 to 3 times the circular pitch, depending upon the speed. There is no fixed rule concerning this. Make width $= 2\frac{1}{2}$ times the circular pitch and calculate p' from the following formula:

$$fp' = 16.8 \frac{W}{s} \quad (2)$$

The thickness of a tooth is made just a little less than one-half the circular pitch to allow for roughness of casting and to give a loose fit of the intermeshing teeth. A fair value as already given is $t = .48 p'$.

Make thickness of rim = $0.12'' + .4p'$. Assume thickness of arms = $.4$ of width and find width and thickness of arm from following formula based on strength of materials.

$$\frac{WR}{y} = \frac{2500cb^2}{6} \quad (3)$$

Give the arms a slight taper toward the rim.

Calculate diameter of shaft from following rational formula:

$$d = 68.5 \sqrt[3]{\frac{H}{6000 N}}$$

A good rule for thickness of hub is to make it = $.8p' + .02 R$.

Length of hub is usually about $5/4$ the width of the teeth. Determine proper size of key from Kent or from standard list of keys.

NOTE: Student should make a complete set of these calculations and tabulate results neatly and hand them in along with the finished drawing. For the general appearance of arms, rim and hub and method of joining these to each other reference must be made to the models in the drawing room and the various gear wheels available in machine shops.

Problem A: Deduce the relation or formula (1) above given.

PART II

GRAPHIC STATICS

Graphic Statics has for its object the determination of the nature and value of the various forces acting in a machine or structure by means of lines drawn to scale and based on the fundamental principles of the force polygon. It is well to note that these same forces can also be determined by analytical methods; but the graphical method is usually much simpler, neater and with ordinary care fully as exact as the nature of the data demands.

The subject will be divided into two parts:—

Part A—Elementary Graphical Statics.

Part B—Graphical Statics of Mechanisms.

In applying the principles of graphic statics to structures and stationary objects upon which external forces are acting, the results are exact. In the case of machines, which are always designed for motion of some sort, the assumption is made that the machine is just on the eve of motion and the results are obtained accordingly. This will be subject to a slight error in that the force sufficient to produce motion will be slightly greater than the one necessary to maintain equilibrium; and indeed if there is much acceleration or inertia involved, the force needed may be a great deal more than in the case of equilibrium, but in general the results will be found satisfactory for machines as well as structures.

PART A. ELEMENTARY GRAPHICAL STATICS

In this portion of the subject, the fundamental principles will be studied and the application of the force triangle and

the force polygon to various problems made clear; and whenever machines are considered, they will be assumed perfectly frictionless and just on the eve of motion as already stated. In the subsequent work of Part B, the various kinds of sliding, journal, tooth and rope friction will be taken up and the method of providing for them in the graphical construction will be shown.

SOME FUNDAMENTAL DEFINITIONS AND SUGGESTIONS

The few following definitions should be thoroughly understood as they are foundation principles of the subject and their application is comparatively simple and easy.

A force is that which tends to change the motion of a body. It is applied to a body at a definite point and in a definite direction. The effect of a force is completely determined when three things are given—its magnitude, its direction, and its point of application. Every force acting upon a body is exerted by some other body, but the problems in Graphic Statics usually concern only the body acted upon.

Resultant is the name given to a single force which is the equivalent in every respect of two or more forces.

Scalar Quantities are those which have a numerical value or magnitude as twenty yards, fifty dollars, etc.

Vector Quantities are those which have both value and direction, as the wind blowing forty miles an hour from the north; or a train going in a certain direction at a given rate of speed. Vector quantities may be fully represented by lines.

Force Polygon or Vector Polygon is the name given to the figure formed by drawing in succession lines representing the magnitude and direction of the forces acting. If a system of forces act upon a given body and that body is in equilibrium under these forces, then the vector polygon forms a closed figure. From this it follows that if a series of forces acting upon a body do not form a closed polygon, then equilibrium does not exist and to produce equilibrium, another force must be applied equal to the closing side of the vector polygon.

The three following simple conditions cover most of the cases that occur in practice. Other cases may be resolved into

one or the other of these by the method of combining forces and getting their resultant.

In each case the body is assumed to be in equilibrium.

Case 1—Only two forces act on the body.

Case 2—Three forces act on the body.

Case 3—Four forces act on the body.

Case 1 is very simple. If only two forces act then these two must be equal and opposite; hence if one vector quantity is known the other follows directly.

Case 2. One of the simplest and most common cases is where a body is in equilibrium under the action of three forces, in which case the two necessary conditions are; first, the three forces must always meet in a common point; and second, the magnitude and directions of each of these three forces is represented by the sides of the triangle formed by drawing lines parallel respectively to each of the three forces. This is called the **force triangle**.

Case 3. Four forces acting may be solved by means of vector polygon if sufficient data is given; or by application of principle of resultant of forces.

APPLICATION OF PRECEDING DEFINITIONS AND PRINCIPLES

Resultant: Two forces AB and AC Fig. 16 are to be replaced by a single force equivalent in every respect to the combined effect of the other two. From a common origin A, draw the two forces AB and AC to scale; then complete the parallelogram by drawing BD and DC. The diagonal AD shown dotted is then the resultant of the two given forces.

Force Triangle: (See Fig. 17a.) Forces F and W equal to AB and AC of Fig. 16 are known in value, location and direction as shown; to find the value of the third force E necessary to maintain equilibrium. **Solution:** The method involves the application of the force triangle and is shown dotted. Selecting any origin as a, construct the force triangle by laying off successively ab equal to F, and bc equal to W; then the closing line ca must equal the third force E in value and direction. To find its location, Fig. 17b, remember that the forces must meet in a common point. Prolong F and W

till they intersect at O, then draw the line OM equal and parallel to *ac* of the force triangle and the problem is complete. By observing closely, it will be seen that the principles of the force triangle and the resultant of forces are identical, the triangle *abc* of Fig. 17a being just like the upper half of ABD of the parallelogram in Fig. 16; of course *ac* being an equilibrant is opposite in direction to the resultant AD of Fig. 16.

Four Forces in Equilibrium: This case may be solved in different ways depending upon how much is known concerning the location, value and direction of the forces; but one of the common cases, and one of the most difficult, is where all forces are known in direction and location and only one, *F*, is known in value, Fig. 18a.

SOLUTION: Student should read this solution carefully. **First:** Forces *F* and *P*, no matter what their values, may be replaced by a resultant *R* which will produce exactly the same effect as *F* and *P* combined; likewise *W* and *X* may be replaced by a resultant *R'*, and we would then have a case of two forces acting namely: *R* and *R'* and these two forces must be equal and opposite in order to be in equilibrium. **Second:** The resultant *R*, of *F* and *P* must necessarily pass through their intersection at *f*; for the same reason *R'* passes through *g*; but since *R* and *R'* are equal and opposite, then their common line of action or direction must be through *f* and *g* and hence the location and direction of the resultant is established. **Third:** Now consider forces *F*, *P* and *R* by themselves. Both the value and direction of *F* is known, the direction of *P* is known; and also the direction of their resultant; *R* being a continuation of the line through *f* and *g*. Then by the principle of resultant of forces we lay off *F* to scale equal to *de* (Fig. 18b); from one end, draw a line parallel to *P*; and from the other, a line parallel to *R*. They intersect at some point *h*. Then *eh* and *dh* represent to scale the values of *P* and *R* respectively. But $R = R'$ therefore *dh* also represents the value of *R'*, which is opposite in direction to *R*. **Fourth:** Now consider *W*, *X*, and *R'* by themselves (Fig. 18c). From preceding Figure, value and direction of *R'* is known, *W* and *X* are known in direction only. By the same principle as in Fig. 18b, lay off the known force *R'* equal to

$h'd'$ and from one end draw line parallel to W ; and from the other end, a line parallel to X . Their intersection at e' gives $h'e'$ and $d'e'$ as the required values of W and X respectively.

Note that Fig. 18b and 18c could be very conveniently combined on the common base line dh and $d'h'$. By examining the force triangle in Fig. 17a and comparing it with Fig. 18b, it is seen that in the force triangle if we are getting the equilibrant force then the arrows point in the one direction continuously around the triangle (see the direction of ac in Fig. 17a); but if it is the value of the resultant that is wanted; then its direction is opposite or opposed to that of the other forces (see the direction of dh in Fig. 18b). This is also true of the force polygon. If the system of forces are in equilibrium, not only do they form a closed polygon, but their arrows all point continuously around the polygon.

GENERAL SUGGESTIONS AND HELPS FOR SOLVING A PROBLEM BY GRAPHICAL METHOD

Case A. Consider just the simplest case where there is only one body acted upon; or, one link to the machine.

FIRST: Determine the number and location, if possible, of all the forces acting on that body.

SECOND: Note the value of as many forces as are given.

THIRD: Then if sufficient data has been given to make the problem a possible one, apply the principle of force triangle and determine the unknown quantities. In general, if there are n conditions, then at least $n-2$ conditions must be given; thus in the force triangle there are six conditions (3 magnitudes and 3 directions); then at least four must be given before the triangle can be constructed, but this may be any four of the six.

Fig. 19a of Instruction Plate No. 6 represents a special case of the application of the force triangle which frequently occurs. The magnitude and direction of F are known, P is known in direction only, and all that is known concerning the third force W is that it must pass through a certain point x . At first sight this appears as if only three conditions were known, viz., two directions and one magnitude, but remembering that in this case the three forces must meet in a common

point, prolong F and P until they intersect, as shown dotted in Figure, and then W passes through x and the intersection of F and P ; hence, three directions and one magnitude now are known and this can readily be solved as follows, (see Fig. 19b).

Draw carefully to scale the force F , then from one end of F , it matters not which, draw a line parallel to P ; from the other end of F draw a line parallel to W . These two lines will intersect forming a triangle afh , the three sides of which represent in magnitude and direction the three forces to which they are parallel. The fact that it does not matter from which end of F you draw P and W is shown by the dotted triangle afh , whose sides are exactly equal to those of the triangle afh .

Case B: Consider a more difficult case where there are a number of links to the machine upon which there are external forces acting and the various links acting on each other (as an example see Fig. 22). Here there are two gear wheels and a fixed bearing making three links altogether. These links act on each other and in addition have external forces P and W acting on them. The method to be used in this case, and in all such cases, is as follows: (Read these carefully).

Rule 1. Notice how many links there are in the machine.

Rule 2. Begin with that link upon which a known force acts, or about which you know $n-2$ of its conditions.

Rule 3. Notice all the forces which act upon that link and what is known about their magnitude and direction.

Rule 4. Apply the principle of the force triangle thus determining the magnitude and direction of all forces acting on the link.

Rule 5. In the application of Rule 4, there is necessarily obtained the value and direction of at least one of the forces acting on the next adjacent link,—since actions and reactions are equal—and this enables the values of the forces on this link to be obtained by treating it the same as the first.

Rule 6. It is thus seen that each separate link becomes a separate problem and may be so treated; the solution of each link giving the needed additional information for the solution of the next, and so on until the problem is finished.

Note also the following cautions:

Caution 1. Never try to gather all the forces acting on a fixed link or support into a force triangle.

Caution 2. Any two parts that are rigidly attached and have exactly the same motion constitute really but one link and are to be treated as such. Thus, since the drum, shaft, and gear 2 of Fig. 22 are keyed to the same shaft and revolve together they form but one link and must be so treated.

Application of Above Rules to Solution of Fig. 22: From Rule 1 we note that there are three links, viz., gear 2, gear 3, and the fixed bearings, or link 1. (The fixed part of a machine is usually marked 1). Applying Rule 2, the known force is W which acts on link 2 (composed of drum, gear, and shaft all fastened together).

From Rule 3, the other forces acting on link 2 are the thrust of gear 3 on 2, and the action of the bearing on 2. These three forces must meet in a common point. Prolong W and tooth thrust of 3 on 2 until they meet, then action of bearing on 2 without friction must go through center of bearing and also through intersection just obtained. This gives us $(n-2)$ conditions.

Now apply Rule 4 and in so doing obtain the value of 3 on 2 which is of course equal and opposite to 2 on 3, and hence we now know one of the forces acting on link 3 and are ready to consider it next as suggested in Rules 5 and 6.

DATA FOR THE VARIOUS PLATES IN GRAPHICS

For the figures that accompany the problems, the student is referred to the Instruction Plates. In each case the student should redraw the figure and then construct the vector polygon alongside of it.

There will be three problems on each plate. Use regular sized sheet of drawing paper 18"x24". Do a little preliminary planning and laying out so that the different problems do not crowd each other. Make it clear on each problem what data was given you, as well as showing your method of solving the question.

IMPORTANT: The scaling off and measuring, especially in the vector diagram should be done very carefully and accurately with a hard lead pencil. After numerical values are

obtained, if desired, drawings may be finished in ink as they make a much neater appearance; but in any case the drawing must first be done neatly and accurately with a hard lead pencil in order that the results may be satisfactory.

Prob. I. Find the magnitude and direction of the resultant of the forces acting on the body as shown in Fig. 20 Instruction Plate No. 7. Scale 96 lbs. = 1". Method of solution is indicated below the Figure. Note that as already mentioned the direction of resultant opposes the motion established by the arrows of the other forces in this force polygon.

Prob. II. A body is in equilibrium under the system of forces as shown in Fig. 21. All of the forces are known in direction and all but two in magnitude. Find the magnitude of the two unknown forces by means of the polygon of forces. Use scale of 20 lbs. = 1".

Prob. III. Figure 2 represents a geared windlass on which a man is exerting a tangential force P at the end of an 18" crank arm, and is raising a weight W of 900 lbs.

The line 3 on 2 represents the direction of the tooth thrust of gear 3 on 2, and as in the case of the ordinary involute tooth, makes an angle as shown of 75° with the line of centers. Make out a little table of results on your plate, and tabulate values as suggested in Fig. 23. Scale of forces 200 lbs. = 1", scale of drawing 1" = 1'.

(b) Check up your graphical result for the force 3 on 2 by means of the principle of moments indicating the work on your plate.

Prob. IV. Two upright supports (Fig. 24) have a wire rope stretched across and a man weighing 150 lbs. is supported by a cage swung from the middle of the span, rope sags or deflects 5 ft. under the load. Determine the stress in the rope between the uprights, the vertical pressure on top of the uprights, and the force which must be applied horizontally at top of supports to prevent bending of the uprights.

Scale of forces 50 lbs. = 1", scale of drawing $\frac{1}{4}$ " = 1'.

Prob. V. The load on one of the driving wheels of a locomotive is 2166 lbs. If wheel is 5 ft. in diameter, determine the horizontal pull necessary to drive the wheel over a rectangular block of iron 4" high placed on the track. Scale of forces 1" = 500 lbs., scale of drawing 1" = 1'.

NOTE: Figures in Prob. V and VI are to be supplied by the student.

Prob. VI. A 40 ft. ladder weighing 80 lbs. is resting against a vertical wall; base of the ladder being 10 ft. from the wall. Find force exerted by ladder against the wall, also the direction and value of force exerted by ladder on the ground. Scales of forces, $1'' = 20$ lbs., scale of drawing, $\frac{1}{4}'' = 1'$.

The use of graphical methods is much facilitated by the adoption of a convenient system of notation. There are generally two figures to letter—the vector diagram, and the drawing or diagram showing the location and direction of forces, often called the space diagram. In the vector diagram, each line represents a force in magnitude and direction, and is designated by small letters at its extremities. In the space diagram, the action line is represented by capital letters, one on each side of the line designated, as shown in Fig. 25.

Prob. VII. An ordinary jib crane Fig. 26 supporting a load of 4,000 lbs. Find the stresses in the tie rope DB, in the mast BC and in the jib AB. Mast is held perfectly vertical by horizontal force H, shown in figure. Determine also value and direction of reaction on the earth.

Mark the parts in tension — and those in compression +.

Check the value obtained for force in rope DB by principle of moments. Assuming the breaking stress of rope to be 720 times the square of the circumference, and using a factor of safety of 16, find the proper size rope to use.

Scale of forces $1'' = 800$ lbs., scale of drawing $\frac{1}{8}'' = 1'$.

Method of Determining Whether Members Are in Compression or Tension: It is sometimes possible to tell at a glance whether a certain link or truss member is in tension or compression, but the safest way is to determine it from the direction of the arrows in the Vector Diagram. As an example, consider the Cantilever Truss of Prob. VIII. which is shown in Fig. 27. Proceed to construct the vector diagram. This is done separately for each place where a number of forces meet in common point always beginning at the point about which most is known. Upon examining Fig 27 closely it is seen that at the lower right hand corner of the Truss three forces CD, DJ and JC meet in a common point p pro-

ducing equilibrium, the stresses in members DJ and JC balancing the external force or load CD. The force triangle or vector polygon for this point is shown by Fig. 30a Instruction Plate No. 8. Of the three forces considered all are known in location and one (CD) is known in value. We lay off cd vertical with arrow pointing down in direction of the line of action of the load. From one end of cd , draw a line parallel to DJ and from the other end of cd , a line parallel to JC forming the force triangle cdj . Since the forces are in equilibrium, the arrows must point consecutively in the one direction around the triangle. The direction of action of cd being known, determines the direction of the other forces and the arrows are put on as indicated in Fig. 30b. This shows that considering the direction of the action of each of these forces on the point p , the member DJ is pushing horizontally to the right and the member JC is pulling up to the left along a line making an angle of 30° to the horizontal; and from this in turn, it is evident that DJ is in compression and JC is in tension. If student has difficulty in applying this test and reaching conclusions properly, he should get additional explanation from the instructor until it is perfectly clear.

Another very neat method of determining the same thing and incidentally also of checking up the numerical values of the forces as obtained graphically is by the "principle of moments." Thus imagine a cutting plane MN passing as shown in Fig. 27; then in order to keep the little piece cut off in equilibrium, external forces equivalent to the internal stresses existing before the truss was cut must be applied at r and t . Let Fig. 31, Plate No. 8, represent the little portion cut away. Then it is evident that in order to maintain equilibrium, viz., to prevent this triangular shaped piece from dropping or rotating, a force F will have to be applied as indicated at t and another force P applied as shown at r . This again shows that DJ is in compression and JC in tension since the direction of forces P and F correspond with the stresses existing at r and t before the plane was cut through. Moreover, from the principle of moments, the algebraic sum of the moments of all the forces with respect to any point must be zero. Take the center of moments at t . Then F has no moment arm and its moment is zero, the load CD of 40

lbs. has a lever arm of st with respect to t and tends to produce clock-wise rotation. The moment of P must oppose and balance this. Erect the perpendicular arm tv , then $P \times tv$ must $= CD \times ts$; every thing is known, or can be measured but P ; solve for P thus determining the value of JC and affording a good check on the results obtained from the vector diagram. Likewise by taking center of moments at r and dropping perpendicular ry , we can find the value of F or its equivalent DJ . This method of obtaining values is very useful and very practical and should be thoroughly understood.

Prob. VIII. A cantilever truss (Fig. 27), is rigidly supported on the left side by two horizontal forces as shown. Determine the stresses in the different members and tabulate your results according to methods shown in Fig. 28. Scale of forces $1'' = 40$ lbs. Scale of drawing, $\frac{1}{4}'' = 1'$.

Prob. IX. The combined weight of elevator and load (Fig. 29), is 1200 lbs. Determine the value of the bearing reactions, also the value of force P necessary to raise the elevator disregarding friction. Tabulate results neatly by the method indicated in Fig. 23. Note that this is a case of four forces acting on the elevator and will have to be solved by method indicated in Figs. 18a, 18b and 18c.

Scale of forces, $1'' = 200$ lbs., scale of drawing, $1'' = 1'$.

Prob. X. Obtain the stresses in the various members of a portion of the Warren Truss shown in Fig. 32.

Scale of forces, $1'' = 500$ lbs., scale of drawing, $1'' = 5'$.

Prob. XI. Engine 10"x12" using steam at 100 lbs. pressure throughout entire stroke connecting rod = four times length of crank. (See Fig. 33).

(a) By inspection or trial determine position of crank for which pressure along the connecting rod is a maximum; position for which pressure on crank pin is a maximum; position for which piston is in the middle of its stroke; also position for which horizontal pressure on main shaft bearing is a maximum. Tabulate these results on your drawing.

(b) Draw the mechanism with the crank in the 60° position and determine the following: pressure between cross-head and guides, force along connecting rod, tangential turning effort at crank-pin, and pressure on crank-shaft bearings caused by thrust along connecting rod.

(c) Check up your value of tangential turning force by analytical method.

(d) If allowable pressure between cross-head and guides is 60 lbs. per sq. in. how many square inches of bearing surface should cross-head have?

Scale of forces, $1'' = 1000$ lbs., scale of drawing, $1\frac{1}{2}'' = 1'$

Prob. XII. Determine stresses in truss shown in Fig. 34a. Make out a table of forces or stresses as indicated in Fig. 28. Scale of forces, $1'' = 50$ lbs., scale of drawing, $\frac{1}{8}'' = 1'$.

In Prob. XII, it will be noted that the values of the reaction of the supports of the truss are not given. Knowing the horizontal distances between the vertical forces, the values of these two reactions may be easily computed analytically by the principle of moments. Students should do this and compare results with the graphical method of determining these values by means of the Polar Diagram (Fig. 34b). Starting at some origin, lay off the external loads consecutively to scale as in a vector diagram on lines parallel to their lines of action in the truss. That is, lay off ab , bc , and cd , which in this case where all the forces are parallel, gives a straight load line. From **any** point O draw Oa , Ob , Oc , Od . Next, go back to the truss diagram and starting with any point p on the line of reaction AE , draw pq , qr , rs , st respectively, parallel to the lines Oa , Ob , Oc , Od of the polar diagram. Notice that these lines pq , qr , etc., are limited by prolongations of the lines of action of the corresponding forces. Join p and t . Then draw Oe parallel to pt , and the point e will divide the load line into ae and ed which are the reactions at the left and right support respectively.

As already indicated the foregoing was a case of parallel forces; but by means of the polar diagram the values can be obtained by the method just given when the forces are not parallel and do not meet in a common point.

It will be noted that with the exception of Prob. XII, all the applications of vector diagram or force polygon thus far have been to cases where forces under consideration all passed through a common point.

Prob. XIII. Apply the general method as described in Prob. XII. to Fig. 35, where the three forces shown F , P , and

W, have values respectively of 50 lbs., 80 lbs. and 120 lbs.; and their positions are as indicated. Find the direction, point of application, and value of their resultant.

SUGGESTIONS: Lay off the vector diagram or force polygon of the three forces in the usual manner, then the resultant force will close the figure as before. This gives its value and direction. Find its point of application in the system by means of a polar diagram and method similar to that used in getting the reactions in Prob. XII. Select the pole at any convenient point and draw the rays to the various corners of the vector diagram. Selecting a suitable origin on the line of action of any one of the three forces draw lines parallel to the corresponding rays till they are intercepted by the line of action of the proper force, thus proceed and the last two or closing lines will intersect each other at the point where resultant must be applied. If the student would take Prob. XII. as solved, and assume that everything was known but the value and location of the right reaction, and notice by working backwards how its value and location could have been determined, then, Prob. XIII will give no trouble.

Scale of forces, $1'' = 50$ lbs., scale of drawing, $6'' = 1'$.

NOTE: The two horizontal reference axes XY and MN are construction lines to enable the student to redraw the Figure and locate the forces in their proper position. Prob. XIII and XIV should go on the same Plate.

Prob. XIV. The truss shown in Fig. 36 is acted on by a wind load normal to the slope of truss and the right support is on rollers. This makes the direction of the right support vertical, while the direction of left support is unknown, but slopes somewhat in the manner indicated in the Figure.

(a) Find value and direction of each reaction graphically by assuming both reactions parallel to the directions of the wind load and then using the resolution of forces.

(b) Find value and direction of each reaction by the usual graphical method as outlined in Prob. XII and Prob. XIII.

(c) Check the values obtained in (a) and (b) by an analytical method.

(d) Find the values of stresses in all the members by usual graphical method.

(e) Compare the values of these stresses in (d) with

results obtained by analytical method of passing a cutting plane and then using "principle of moments" as already outlined in Fig. 31.

Line MN in Fig. 36 represents one of these cutting planes.

Scale of forces, 1" = 200 lbs., scale of drawing, $\frac{1}{2}$ " = 1'.

SUGGESTIONS: In using method (a), lay off load line as in Fig. 34b, select some point O for a pole and draw the rays forming the polar diagram. Then starting at the left support as an origin, construct the equilibrium polygon by drawing lines parallel to the corresponding rays in the polar diagram being intercepted by the various lines of actions of the corresponding forces, produced if necessary; the last line falling on the line of action of R_2 produced. Then draw the closing line of the figure from this intersection to the origin. Then an element drawn through O of polar diagram will intersect on load line the value of components of R_1 and R_2 in direction of wind load. From which, knowing the actual direction of R_2 , the true values and directions of both may be found.

(b) Proceed just as in (a) except the last line laid off in equilibrium polygon will fall on the true line of action of R_2 , produced; and likewise the element drawn through O of polar diagram, parallel to closing line of equilibrium polygon will intersect a vertical line erected from the bottom end of the load line. This vertical intercept is then R_2 and a line from the end of R_2 to the other end of load line gives value and direction of R_1 .

(c) Find the resultant of the wind loads and its point of application. The three external forces on the truss must then meet at a common point. Produce this resultant till it intersects R_2 produced and then R_1 must go through the left support and this intersection. Its numerical value is then easily found by principle of moments.

(d) and (e) should need no further explanation.

The following supplement problems afford a good practice in the application of the principles of graphics.

SUPPLEMENT PROBLEMS

Prob. XV. Given a crane (Fig. 82) loaded with _____ tons.

Determine the stress in AB and AC graphically.

Determine the bearing reaction R_1 , and R_2 , by principle of moments.

If all parts were made of wood, determine the dimensions of, and design the entire crane.

Prob. XVI. The pull required to keep a one ton wagon moving on a level road is 250 lbs.

Determine graphically the force necessary to pull the same wagon up a slope of 20%.

Prob. XVII. Centers of gravity and moments of inertia may be worked out very neatly by means of graphical methods; and are often so done in practice. The method for center of gravity is quite simple. (Fig. 83). Divide the area under consideration into several parts having regular shapes, such as rectangles, triangles, etc. Consider the area of each as a force acting at its center of figure both horizontally and vertically. Then locate the single reaction which would hold all these forces in equilibrium. Do this in the usual way by laying off a load line, selecting some pole O, constructing the polar diagram and then transferring the proper lines to the corresponding lines of action of the forces in the equilibrium polygon. Both the horizontal and vertical polygon must be used in order to locate the point on the intersection of the two axes.

Prob. XVIII. Use same figure as in Prob. XVII and determine its moment of inertia. To do this reconstruct the force polygon, choosing the pole distance equal to $\frac{1}{2}$ of the sum of the area of the figure. Divide the area into 10 parts by horizontal lines. Then, twice this pole distance multiplied by the area of the equilibrium polygon equals the moment of inertia of the area around the horizontal axis. It also equals the area of the body multiplied by the area of the equilibrium polygon. Use a planimeter to determine areas.

PART B. GRAPHICAL STATICS OF MECHANISMS

It is assumed that anyone undertaking this part of the work has already been through Part A (Elementary Graphics), as many of the principles therein considered are necessary in this. The chief new points to consider are the effects of friction—the various kinds—on the construction of the force diagram.

In all this work, it will be assumed, as already mentioned, that the machine is just about to move; in other words, just in equilibrium; and that just at this instant the coefficient of friction is the same as that of motion.

With this assumption, and disregarding the force needed for acceleration in certain kinds of machines, the graphical determination of the forces is entirely satisfactory; and frequently is much easier to make than the analytical one.

The object of the study of graphical statics of mechanism is to enable us to find the value and direction of the forces acting on the different links of a machine, and also to determine the machine's efficiency.

Friction: Friction is a force which acts between two bodies at their point of contact so as to resist motion upon each other. The amount of friction varies greatly depending upon the nature of surfaces in contact, state of lubrication, etc. This makes it difficult to decide the exact allowance to be made for friction in the graphical method, but the same difficulty and lack of exactness would also be true in case of the analytical method.

In any case, what is done is to use the average values of friction obtained by experiment for conditions and materials approximately the same as those in the problem under consideration.

Angle of Friction: Without friction the line of action between two surfaces in contact is normal to their surfaces. See Fig. 37, Instruction Plate No. 9. If the two blocks there shown are sliding on each other without friction, their common line of action is as shown dotted, normal to the surface in contact. If, however, friction exists and the blocks are moving in direction indicated by their arrows then their line of

action would be shown by the solid line AB; and the angle α which this force makes with the normal line is called the angle of friction. Of course the poorer the lubrication, the greater the friction and the larger the angle of friction becomes.

Coefficient of Friction is the tangent of the angle of friction. Thus, if the coefficient of friction in Fig. 38 was one-third, then to locate the line of action of the forces, start at the point of contact between the two surfaces p and measure out three equal spaces, pa , ab , bc , on the normal and then up one space on a line perpendicular to the normal as cd , then the line through d and the origin p gives the line of action of the two forces. At first there is always some difficulty in deciding whether the distance cd in Fig. 38 should be laid off above or below, the normal: thus laying it off below gives MN as the line of action, which is wrong. This difficulty may always be overcome by noting the direction of motion of the two links. Referring again to Fig. 37, it will be noted that without friction the action of 2 on 3 is normal to the surface and therefore has no effect whatever in either retarding or assisting the motion of 3 over 2, but noticing the line AB it is seen that 2 on 3 acts partly to resist that motion, and thus is in accordance with the definition of friction, while if MN were taken as the line of action, it would appear from the direction of 2 on 3, that friction was aiding 3 in its motion over 2 which is manifestly wrong.

Efficiency of a machine is the ratio of the work gotten out to the work put in. This is vastly different from saying that it is the ratio of the force gotten out to the force put in, since work involves the idea of distance. Now, since in graphical statics we do not deal with questions of distance through which the forces act, but merely their direction and values, we cannot use this work relation to determine the efficiency; but must determine it by some relation of the forces involved without considering the distances through which the forces act.

Method A. Suppose a machine to be perfectly frictionless, and by working it through graphically it is found that a force P , of 60 lbs. exerted at the driving end will lift the weight W of 2 tons for which the machine was designed.

Again, working this same machine and considering friction, it is found that a force F of 75 lbs. is now necessary to lift the same weight W of 2 tons.

Then, since the first imaginary case represented a perfect machine or one whose efficiency is 100 per cent., it follows that,

actual efficiency : 100 per cent. : : 60 : 75, or
 efficiency = $60 \div 75 = 80$ per cent.; or efficiency = $P \div F$,
 where P = force necessary at the driving end without friction,
 and F = force necessary with friction. Both of these values
 are obtained during the graphical solution of the problem and
 hence the efficiency is readily determined.

Method B: Suppose friction to exist, and let F be the driving force, and p the distance through which it acts; Q the resistance, and q the distance through which it is overcome; and let E represent efficiency. Then

$$E = Qq \div Fp \quad (4).$$

Now, if there were no friction, a smaller driving force P would suffice to overcome the same resistance Q and in that case since efficiency was perfect, work gotten out would exactly equal work put in, or $Pp = Qq$, which substituted in equation (4) above gives

$$E = Pp \div Fp = P \div F,$$

or exactly the same as given by method A.

There is really no difference in the two methods. The algebraic proof is so simple and so nearly self-evident that method A simply appropriates as being true what is worked out a little more mathematically in method B.

When two surfaces or links of a machine slide on each other, there are an infinite number of lines of action or forces between the two surfaces in contact; but it is necessary to combine these into a single resultant whose effect is the same as the combined effects of all the components.

This is done by assuming all the force to be applied at the middle of the surfaces in contact. See Fig. 39. Here links 4 and 5 act and react on each other over the entire surface from R to S ; but the resultant force is placed at the middle point p and the action of 4 on 5 is thereby reduced to a single line of force.

The problems for the work in Graphic Statics of Mechanisms consist of a number of full sized Plates containing drawings of different mechanisms and the various lines and forces are to be placed right on the drawing on the links upon which they act so that the whole thing represents to the eye a true picture of the forces as they exist. The first six Plates in Graphical Statics of Mechanisms are shown in the back of the book.

Useful Suggestions: Work the problem all the way through without friction first. This will make the more difficult case with friction much easier. Use a hard lead pencil with a sharp point. Make fine lines and be as accurate as possible in the drawing and measurement, and be sure to label all the forces. Label them not only when you draw them in their proper position in the figure, but also label them carefully in the force polygon.

Before beginning any Plate in Graphical Statics, always examine it carefully and see how the machine works. Also read carefully all printed instructions contained on the Plate itself.

At points of application of all forces in position, small shaded parallelograms are to be placed, the relative motions of the pieces indicated, and the forces fully and distinctly marked with arrows pointing away from the surface of contact as shown in Figs. 37 and 39.

In fastening the drawing on the board, select some particular reference line as being perfectly horizontal or perfectly vertical and fasten the drawing accordingly. It will be noticed that lines which should be exactly horizontal and angles that should be exact right angles have become slightly distorted in the making of the print.

All forces without friction are to be drawn **dash and dot**; all forces with friction, **solid**.

SUGGESTIONS AND QUESTIONS FOR VARIOUS PLATES

Plate 1: There are three separate sets of problems on this plate. Do the elevator problem in the upper left-hand corner first. Notice that the only kind of friction involved in this problem is sliding friction. Do not forget the little shaded

parallelograms to be placed at points of application of all forces in position. Work the problem through first without friction, both lifting and lowering; then with friction, lifting and lowering, and finally determine the efficiency for both lifting and lowering. Above everything else be sure to understand what you are doing in this first problem as time apparently lost here in thoroughly mastering the principles involved will be time well spent. Note that this is a case of four forces acting on the one piece.

Having finished the elevator problem, next do the wedge problem in the upper right-hand corner, following the same general methods as for the elevator.

In the wedge problem, be careful of the direction of the arrows in the last force triangle for lowering with friction, and also be careful in determining the efficiency of the machine for lowering.

In the third set of problems found on the lower half of the sheet, we have a case of journal friction while the first two sets of problems involved nothing but simple sliding friction. Notice that there are seven different little problems each consisting of three moving links and one fixed link, the hatching representing the wall or some fixed piece. The object is to locate the line of action of the force (both with and without friction) for the middle link **only**.

Journal Friction: For method of operation in the case of journal friction see Fig. 40. Without friction, it is simple enough. The common line of action of force 2 on 3 and 4 on 3 passes through the center of the journal pins as indicated by the dotted lines.

For the case with friction proceed as follows:

First: Determine the radius of the friction circle. To do this, draw the journal circle Fig. 41 and pass a horizontal line OA through the center intersecting the circumference at p; then lay off the angle of friction DOA in the usual way on this horizontal line. Note the point b where line OD cuts the journal circle, then the distance bp is the radius of the friction circle. With O as a center construct the friction circle.

Second: Note the point of contact between the links 2 and 3, and between 3 and 4. This will be at the top or bottom, according to which direction the motion is taking place and

according to which link the eye is on. Mark these contacts in the usual way with small shaded rectangles.

Third: Determine whether the angles between 2 and 3, and 3 and 4 are opening or closing and designate it on the figure; from this determine the direction of motion of the shaded rectangles and indicate same by arrows. Then without measuring to scale, lay off roughly the line of action with friction ft (it does not matter particularly how large the angle of friction is made; what is wanted is to slant it on that side of the normal line where it belongs; thus ft and rh are correct for the direction of arrows as shown).

Fourth: Note on which side of the center of the journal circle falls that portion of the friction lines ft and hr projecting into the journal. This indicates the side of the friction circle to which the line of action with friction must be drawn tangent, thus the lower part of ft is to the left of the center of its journal circle, and the upper part of rh is to the right of the center of its journal circle, therefore the line of action with friction is drawn tangent to friction circles as shown by line XY in the Figure.

Proceed in this manner for all these journal problems. For the proof of the theory of the friction circle, student is referred to Article 4 of *Graphical Statics of Mechanism*, by Gustav Herrman, translated by A. P. Smith.

The following questions about Plate 1, as well as the various questions following subsequent Plates, should be answered by the student in each case before going on with the next succeeding Plate.

Question 1. Would a pull of 100 lbs. raise the 100 lb. bag in the elevator problem (assuming no friction and neglecting weight of elevator); and give reason?

Question 2. Note carefully the value for efficiency of wedge when lowering and be prepared to explain it.

Question 3. How do you explain the fact in this wedge problem that so small a pull is sufficient to raise a weight of 2000 lbs? Are we getting more work out of the machine than is put in?

Question 4. What useful purpose does such a mechanical device, as the wedge problem proves itself to be in lowering.

serve in actual practice? Name some machine part where such a principle is made good use of.

Question 5. How can you tell whether the angle is opening or closing in the last linkage?

Question 6. In the wedge problem, how can you tell whether link 2 will slide down and bear against 1 on the right, or whether it will be forced over and bear on 1 on the left?

Plate II: This consists of two parts. First, determine the direction and value of the forces acting in the different links of the shaper. Then locate the line of tooth-thrust according to the instructions for the four pairs of gear wheels shown. Note that the small arcs of circles represent portions of the pitch circles of the mating gears.

The shaper problem involves nothing new, being the application of the principles of sliding friction and journal friction as learned from preceding plate. Assume the respective lines of action of Q and P to be the same both with and without friction. Note that P is really a tooth-thrust between a pair of gears; but not having had tooth friction as yet, the direction of P is given to the student.

Question 1. Note that this machine with a uniform motion of the driving pinion gives a quick return motion to the tool. Explain the advantage of this.

Question 2. Will the value of P be the same throughout the entire forward or cutting stroke if Q remains constant, and give your reason?

Problem 3. Suppose that the gear wheel, link 4, is revolving at a uniform speed of $7\frac{1}{2}$ revolutions per minute, how many seconds will it take the cutting tool to make its complete forward stroke and how many seconds for the return stroke?

NOTE: This problem (3) is to be worked out neatly in ink in the lower right-hand corner of the plate and handed in; student to draw in lead pencil on the figure itself whatever lines are necessary to show how problem was done.

Tooth Friction: In the last problem Plate II, all that is wanted is the location of the tooth-thrust both with and without friction. The one great law underlying all properly constructed gear teeth is that the normal to the surfaces of the teeth in contact must always pass through the pitch point. Therefore, without friction since the line of action must be

normal to the surfaces the tooth-thrust passes through the pitch point; and considering the case most frequently met with, viz.: involute teeth, this thrust makes an angle of 75° with the line joining the centers of the two gears. The only other point is to decide in which direction the thrust slants, whether to the right or to the left. This is determined by noticing which is the driver and which the driven wheel; and also their direction of motion. Then the thrust of the driver will be through the pitch point in such a direction as to transmit the rotation to the driven wheel and the direction of the slant will be such as to tend to push the driven wheel away from the driver. This determines fully the line of action of thrust without friction. The line of action with friction is parallel to it and at a distance from it an amount equal to $\frac{1}{2}\mu t$, where μ is coefficient of tooth friction, and t is the circular pitch. To determine on which side of the tooth-thrust without friction the thrust with friction comes, the student should always remember that the effect of the friction is to lengthen the arm of the driver and shorten that of the driven; hence, line of action with friction is parallel to the thrust without friction and is moved toward the center of the driven wheel an amount $= \frac{1}{2}\mu t$.

Theory of Tooth Friction: The proof that the effect of friction is to move the tooth-thrust into a new position parallel to itself and away from the driver an amount $= \frac{1}{2}\mu t$, is shown in Fig. 42. Let A represent the driver and B the driven wheel. The tooth-thrust, or action of A on B, without friction is shown dotted, passing through the pitch point p , and making the angle of 75° as already mentioned.

WITH FRICTION: "To prove that with friction this tooth-thrust XX moves out an amount pb , into the parallel position bN , the distance pb being $= \frac{1}{2}\mu t$." In this proof, the assumption is made that corresponds with average working conditions of the gears; namely, two pairs of teeth in contact and each pair carrying one half the tooth load. First, let A_1 and A_2 represent the two driver teeth transmitting the load through B_1 and B_2 . The direction of the relative sliding motion between the mating teeth is indicated by the arrows on the small shaded rectangles. Laying off the angle of friction sdc in the usual way, the thrust of A_2 on B_2 is along the line cs ; likewise

the thrust of A_1 on B_1 is along the line tf . The resultant of these two forces must go through their point of intersection at b , and since these two thrusts are equal and make equal angles with the line XX , the resultant tooth-thrust with friction, or line bN , must be parallel to XX , and at a distance of pb from it. Second: To find the value of distance pb . The distance $st =$ approximately the circular pitch. Let α in the figure represent the angle of friction, then μ , or the coefficient of friction, $=\tan \alpha$. In the right triangle bps , the side $pb = ps \tan \alpha$; substitute for ps its value approximately $\frac{1}{2}$ circular pitch or $\frac{1}{2} t$ and we obtain $pb = \frac{1}{2} \mu t$.

Plate III: This involves the application of the tooth-thrust principle to a geared windlass problem, the only new point in this plate being the question of rope friction due to the stiffness of the rope. In laying off the tooth-thrust with friction, obtain the value of t , the circular pitch, directly from the drawing by measurement. The line of action of Q without friction would be vertically up through the middle of the rope. The effect of the stiffness of the rope is to move the line of action of Q a certain distance toward the outer edge of the rope. This distance depends upon the coefficient of rope stiffness. For the ordinary size and kind of rope used for this purpose, the coefficient may be taken as .23 and the distance out parallel to itself that the line of action of Q is moved is equal to $.23 d^2$ where d is in inches.

(Note the effect that the scale of the drawing has on this distance when laid out graphically because of the d^2 ; and provide for that in all cases where drawing is not full size.)

Question 1. How is it that the application of so small a force on link 2 is able to raise so heavy a weight as 3000 lbs.?

Question 2. How far does the weight rise when the force P is applied through a distance of 2 ft.?

Question 3. How far does the weight rise with one revolution of gear 2?

Determine this by measurement from the drawing itself and check the result by means of the numerical values of P and Q as obtained graphically without friction.

Question 4. Determine the value of P without friction by means of the principle of moments and compare with results obtained by graphical method.

NOTE: This problem (4) with its explanation is to be worked out neatly in the upper right-hand corner and handed in with the finished sheet.

Plate IV: The new principle involved in this plate is the handling of the forces when the use of a belt is introduced into the problem. The way this is done is by replacing the two belt forces, i.e., tension in the tight side and tension in the slack side, by a resultant belt pull whose effect will be exactly the same as the combined effect of the two belt pulls.

BELT RESULTANT: A more thorough discussion of the question of belting and the theory underlying the formula upon which the graphical treatment rests, is given in a subsequent portion of the book. A brief outline will be given here. The tension in the driving side of a belt when the pulleys are in motion is always greater than the tension in the driven side by an amount depending upon the friction between the belt and pulleys. The amount of this friction in turn depends upon the material of belt and pulley, whether kept dry or oily, and also upon the arc of contact or wrap between belt and pulley. It will be noticed that the two tensions oppose each other in their effect upon the pulley; one tending to produce a clockwise and the other a counter-clockwise rotation, and the real effective driving or pulling force at the rim of the pulley is the difference between these two tensions.

To replace these two tensions by a resultant force is very simple, provided we know the ratio between these two tensions. Fig. 43 gives a diagram by means of which this ratio is readily obtained. All that is necessary in any case is to know the coefficient of belt friction, and to measure the angle of wrap or arc of contact; then lay off the arc of contact in the figure from the origin OA around in a clockwise direction. Draw a radial line through the end of this arc till it is intersected by the spiral curve corresponding to the coefficient of friction required. The ratio of this radial intercept to the radius OA of the base circle gives the ratio of the two belt tensions. The figure shows the ratio for a case where arc of contact is 150° and coefficient of friction is .28. The ratio = $OM \div OA$.

The belt formula from which the spiral of Fig. 43 is constructed and whose derivation is given later in the book, is

$$\log \frac{T_1}{T_2} = 2.729 \mu n \quad (5).$$

Where T_1 and T_2 are the tensions in the tight and slack side respectively, μ is the coefficient of friction, and n is the arc of contact expressed in fractions of a circumference or,

$$n = \text{arc of contact in degrees} \div 360^\circ.$$

The various spirals shown in the figure for the different coefficients of friction were obtained by substituting in formula (5) various values of n , finding the number corresponding to the logarithm, then laying off the corresponding radial lines from O so that the ratio of their length to the fixed radius OA agrees with this number; and then plotting a curve through the series of points thus obtained. Student should occasionally check up his reading from the figure in any particular case by substituting in formula (5) and working out the numerical value of the ratio for himself.

Having obtained the ratio of the tensions, the graphical application is illustrated in Figs. 44, 45, 46 for the three cases of parallel belts, crossed belt, and large and small pulley. In the case of Fig. 44, divide the distance ac into two parts ab and bc , so that

$$bc \div ab = T_1 \div T_2,$$

then the resultant belt pull which replaces the other two tensions is drawn parallel to them through b . In Fig. 45, from the point p , lay off pa and pb along the tight and slack side of belt respectively, in the ratio of T_1 to T_2 and obtain the resultant in the usual manner by completing the parallelogram. In Fig. 46, produce the lines of action of the belt till they intersect at p . Lay off pa and pb and proceed as before.

NOTE: In all three cases it will be seen that the resultant goes through the point of intersection of the two tensions, is always between the two tensions, and always lies nearer the line of action of T_1 .

A belt depends for its action upon friction, and hence the line of action of the belt resultant will be the same both with and without friction.

Question 1. By inspection of the figure in Plate IV, determine whether P should be greater than Q and give your reasons.

Question 2. Explain why the resultant belt pull is greater than either of the two tensions in the belt; although the tension in the slack side tends to produce the opposite rotation from that of the tension in the tight side, and the resultant belt pull is supposed to have exactly the same effect as the other two tensions combined.

Question 3. By the principle of moments and the work principle, determine analytically the value of 2 on 3 without friction.

NOTE: Problem 3 is to be worked out neatly in ink in the upper left-hand corner and handed in with the finished plate.

Plate V: In this stone-crusher, notice the effect of the toggle-joint arrangement, how a small force applied at the right place produces an enormous pressure at some other point. One of the most difficult questions to determine in this plate is whether the angle between 2 and 3 is opening or closing.

Question 1. Never begin one of these plates in Graphical Statics by attempting to gather together into a force polygon the various forces acting on the fixed link. Why?

Plate VI: There is no new principle in this Plate. The student will notice carefully that it is a pump, not an engine.

Question 1. What is the advantage of a crossed belt over an open one?

The remaining plates contain no new principles. The question of rolling friction is purposely omitted. The question of ball bearings and roller bearings form an important discussion by themselves, and in their practical application have reduced the friction in journals, shafts, etc., to a very small amount.

Graphical Constructions: Figs. 47 and 48 represent a convenient graphical construction for drawing a line that would, if prolonged, go through the point of intersection of two other lines, when this intersection comes outside the limits of the board. Fig. 47 shows the construction when the point is outside of the two known lines, and Fig. 48 shows it when the point lies within the two lines. In Fig. 47 let F and P be the lines of action of two forces, and it is desired to draw a line through x that shall pass also through the intersection of F and P.

METHOD: Draw a straight line AB cutting F and P and

passing through x . As near the edge of the board as convenient, draw CD parallel to AB . Draw the diagonal xC . From point M where AB cuts the line of P , draw ME parallel to F and intersecting the diagonal at E . Join E and H , and a line through x parallel to EH will pass through the point of intersection of P and F as can readily be proved by similar triangles.

METHOD IN FIG. 48: Lines F and P intersect beyond the board, and it is desired to pass a line through x and the intersection of F and P . Draw as before two parallel reference lines AB and CD . Draw the diagonal BC . From x draw a line parallel to F and intersecting BC at y . From y draw a line parallel to P , intersecting CD at t . The line joining x and t will pass through the intersection of F and P .

A close inspection will show method in Fig. 48 to be a case of working backward through method in Fig. 47.

The three following problems illustrate the possibilities of graphical constructions. Each of them admit of a very neat graphical solution.

SUPPLEMENT PROBLEMS

Prob. XIX: Two trains A and B are approaching each other on intersecting tracks. A is 16 miles west of the crossing and approaching at the rate of 40 miles an hour; B is 12 miles from the crossing and approaching at the rate of 20 miles an hour. The first track extends due east and west; the track that B runs on extends in a straight line 15° east of north and 15° west of south. Train B is going in the south-southwesterly direction.

(a) How many miles in a straight line separate the two trains at the time when they are nearest to each other?

(b) How far, and in what direction, from the crossing will they each be at this time?

Prob. XX: Two points, A and B , are 64 ft. apart. It is desired that a body M shall traverse this distance in 20 seconds. Character of M 's motion is as follows: Starting from rest at A , during the first four seconds it is to be uniformly accelerated, during the next twelve seconds moves uniformly

and during the last four seconds is uniformly retarded coming to rest at B.

Determine graphically, and lay off on the line representing the distance AB, the space traversed in each second.

Prob. XXI: Determine graphically the center of gravity of an L-shaped figure, if the total height of vertical arm is 8" and its thickness $1\frac{1}{2}$ ", while the width of horizontal arm measured from where it joins the upright is 5" and its thickness is $1\frac{3}{4}$ ".

PART III

MACHINE DESIGN

Introduction: In general the study of a machine may be taken up in three ways. First, we may consider from a geometrical point of view the relative motion of the various parts of the machine without any regard to the nature and amount of the forces producing this motion. Second, the amount and direction of the forces acting on the various parts of the machine may be dealt with and the resulting transformations of energy determined. Third, we may investigate the action of these forces in producing stresses in the different members of the machine and thus determine the proper size, shape and strength of each part in order that it may safely do the work for which it was designed.

Kinematics: The science dealing with the first-named class of problems is termed **Kinematics of Machines**, which may be defined as the science which treats of the relative motion of machine parts without considering the forces or stresses involved.

This subject includes constraint of motion, determination of velocity and acceleration of the links, or any points in the links of a machine; and in general, all questions pertaining to the character and amount of motion involved. While questions of force and stress are not directly treated, many useful facts about these stresses and forces may be determined indirectly.

Since work involves both force and distance, or force and velocity; then, if we know the amount of work a machine is doing, by kinematics we can determine the velocity factor, and from that the force is indirectly obtained. Moreover the acceleration and inertia effect on certain links is often the

cause of their worst stresses, and without kinematics the acceleration in many cases would be unknown. In such cases the determination of the stresses by the usual means of graphical statics would give results that were very far from the actual values.

Graphical Statics: The graphical method of determining the forces acting on the different members of structures and machines has already been explained. This prepares for the third and last step, the actual design of the machine.

Machine Design: This subject really includes both of the two foregoing. It appropriates all the results concerning the amount and nature of the forces that can be obtained by kinematics, graphics, or by analytical investigation; and by combining these results with the knowledge of strength of materials and factors of safety, determines the proper shape and size of the different parts.

In the following pages no attempt will be made to give, in any sense, a complete treatment of the subject. A few of the common methods of power transmission will be investigated and the application of the principles of machine design shown in the actual design of several machine parts; the aim being to establish the principles underlying true design, and to train the student in the habit of keeping systematic calculations and records and of using proper methods of design.

Theory vs. Practice in Design: In every branch or department of work there seems to be a great deal of controversy and lack of agreement between the theoretical and the practical; and a little discussion of this question may not be out of order. The chief trouble seems to be a failure on the part of both sides to recognize the valuable merits of the other; and hence a desire to claim more than the proportionate share of the credit of attainment. In reality, both are absolutely necessary. Practice has repeatedly shown that the theory was at fault. Results and designs apparently worked out on paper correctly, have been shown unsafe when put into practical use; and it is unwise and foolish to ignore or underestimate the importance of the vast amount of useful knowledge that has been accumulated as the result of practice and experience only. On the other hand, there is a **true theory** of design underlying all practical development, and it is safe

to say that the best results will never be accomplished in any case until this theory is completely understood and intelligently applied. Theory is the attempt on the part of imperfect man to get at the truth; practice is the infallible judgment passed upon it; hence, the true value of both should be recognized. The function of practice is to reveal certain mistakes that the theoretical investigator has made; and thus lead him on eventually to the discovery of the true theory, and to its successful practical application. Theory and practice are mutually dependent upon each other for complete success. It is true that without using any theory a practical man may build a machine that will safely do all that is required of it, while another man through some slight mistake or oversight in his theory finds his machine breaks down when put into operation; and this accounts in a large measure for the popularity of the practical side. But if, as is likely to be the case, the first machine is **uneconomical** in the use of material, having been made much stronger than is necessary in order to be sure of being on the safe side, then that man has failed also, although the failure is not so evident. Again when a machine is designed properly without unnecessary excess of strength, the resulting machine always appeals to the eye because of its beauty and graceful appearance; in other words, it looks right, and hence an experienced man of good judgment and with a mechanically trained eye can accomplish surprising results, by simply making things according to looks.

Also, in many manufacturing firms where they turn out large quantities of certain kinds of product, they gradually standardize their work and compile tables and charts from which accurate results can be obtained very quickly by one familiar with the tables. In this case the designer should become thoroughly used to the tables as quickly as possible, but even there, originally there must have been a careful study of theory as well as practice before these tables were compiled. Moreover, a careful study and examination of similar machines built for similar purposes will often reveal facts and conclusions which, unaided, the theorist could have only reached after long and tedious effort and experience.

But with all these facts, there does exist a necessity for the

engineer to know the theory, not only because it is the **true basis**, but also because frequently the problem presented to him will have new and original features connected with it, totally unlike anything that has been standardized or built before; in which case he must depend almost wholly upon his knowledge of the theoretical principles of design.

Hand-Books and Empirical Data: In special cases the theory underlying certain formulas and design is so complicated that the correct solution requires the labor of some investigator who makes this subject his specialty. Also, in some instances the theory leads to such complicated formulas that simple empirical formulas, so called, are substituted for the true formula, but these empirical formulas in most instances are really rational in their derivation and give results in every way satisfactory. In both of these cases the student is justified in accepting the results of other men's labor and applying them. Hence, good hand-books and empirical formula should be used freely though with discretion, but in all cases where possible the designer should feel a confidence in his work born of the fact that he understands the true principles and theory underlying his design.

Notes and Calculations: A beginner should form at once the habit of carefully and systematically making and recording calculations. All estimating, figuring and calculating, no matter of how rough or provisional a nature, should be done in a permanent note-book provided for that purpose. Do not use odds and ends of loose scraps of paper even for the first preliminary figuring, as much valuable time will surely be lost by the operation. It does not take much longer to record these calculations in a certain portion of the note-book, and then you will know where they are when you want to refer to them. Besides, you are cultivating a habit of neatness and order thereby.

In the following problems many suggestions will be made at first in order to accustom the student to the method of systematically recording results, as well as to aid him in the various steps of the design. Always reserve one page in the note-book for the mere tabulation of results, using the succeeding pages to make the calculations and do the figuring on. In that way when the problem is finally finished, no matter

how much figuring was involved, all of the valuable data is gathered together on one page, and if it is desired to note how any one special value or dimension was worked out, this can be obtained by turning over to the corresponding page.

Prob 1: Compute and draw a multiple collar steel shaft such as is used on propeller shafts on ships to take an end thrust of 60,000 lbs., allowable pressure per sq. in. of bearing surface = 60 lbs., diameter of shaft = 10", pitch of collars to be $4\frac{1}{4}$ ", collars to be of square cross section and thickness of collar = 2".

In working up this problem there will not be many calculations to make. Keep them neatly and systematically, however.

Question 1. Why is the bearing pressure made so low in Prob. 1?

Prob. 2: Two circular cast iron discs 12" in diameter are to be kept at a fixed distance of 4" apart by a number of bolts, nuts, etc., arranged in a circle near the disc's edge. A force of 200 lbs. per sq. in. tends alternately to separate and then force together these two plates (limit in number of bolts is between 6 and 10). Design the discs, bolts and attachments to meet the requirements of the problem. Draw full size two views of one of the bolts with all necessary attachments.

Work out all necessary values for this problem and tabulate results neatly using following symbols:

A = area of disc.

B = total pressure on face of disc.

C = allowable shearing stress in fibers of disc.

D = number of bolts selected.

E = allowable stress in bolts.

F = diameter of bolts.

G = thickness of disc based on shearing around one fastening.

H = thickness of disc based on shearing of the entire middle portion as one piece.

Whatever method of fastening is employed, whether collars, nuts, etc., test everything for shear and crushing stresses, using additional symbols to designate the various other dimensions that are part of each individual design.

NOTE: In this problem, consider nothing but the simple, direct stresses of tension, compression and shear, and use the larger value of G and H in your design.

Prob. 3: One method of staying the end of a boiler is shown in Fig. 49, Instruction Plate No. 11.

The diagonal stay is fastened to the side of the boiler by means of two rivets and to the end of the boiler by a pin in double shear. Area supported by each diagonal stay is 8" x 14", boiler pressure = 185 lbs. absolute. Stay is cylindrical in shape with one end flattened out properly for riveting and the other a forked end for receiving the pin.

(a) Determine the diameter of the stay, using a proper factor of safety.

(b) Determine the size of rivets and pin so that the stay will be equally strong in every part. (Assume that stay and rivets are made of same material, boiler steel, and that shearing strength is $\frac{4}{5}$ of tensile strength.)

Power Transmission: The transmission of power from one place to another constitutes an important and essential part of the work of machinery. Among some of the common methods of transmitting motion or power from one shaft to another may be mentioned the use of (a) belts and pulleys, (b) ropes and wire drives, (c) friction wheels, (d) gear wheels, (e) couplings—rigid and flexible.

Rope drives and wire drives are particularly useful in cases where power is to be transmitted to a considerable distance. They possess several decided advantages over belts and have displaced them in certain operations.

Friction wheels, belts and pulleys, wire and rope drives, all depend for their successful action upon friction. The advantage of this over the positive action of gear wheels, etc., lies in the protection to the connected machinery and the ease of stopping and starting.

BELTS AND PULLEYS

The most common material used for making belts is ox-hide leather, tanned with oak bark. The leather from the back of the animal makes the best belts. The leather is from $\frac{3}{16}$ to $\frac{1}{4}$ of an inch thick and can be obtained in strips up to

5 ft. long. Single belts are made of one thickness, and double belts of two thicknesses of leather. The outside of the leather, called the grain or hair side, is smoother than the flesh side; authorities differ as to which is the proper side to run next to the pulley, but the generally accepted practice is to run the smooth or hair side next to the pulley for the two following reasons: First, the friction between belt and pulley will be greater, and thus enable more power to be transmitted. Second, the outside fibers of the belt will be subject to tension as belt wraps around pulley and since the flesh side stands tension better than the grain side, the belt will last longer.

Other Kinds of Belting: Among these may be mentioned cotton belting, rubber belting and leather link-belting.

COTTON BELTING is superior to leather for use in damp situations. It is also cheaper, and can be made of great length and strength without the numerous joints found in leather belting. It is made in width up to 5 ft., and the necessary thickness is obtained by sewing together from four to ten plies of cotton duck.

INDIA-RUBBER BELTING is made by cementing several plies of cotton duck together with India rubber. This belt is considered the best for damp situations as it does not absorb moisture and stretch and decay.

LEATHER-LINK BELTING is made up of numbers of small links of leather fastened in such a way as to make a very flexible belt, suitable for high speeds and small pulleys.

Theory of Belting: A pulley is driven by means of the friction between the belt and the face of the pulley. When the pulley is at rest, the tensions in the two sides of the belt are about the same; but while in motion, and transmitting power, the tension in the tight or driving side of the belt is much greater than the tension in the loose or slack side; and the difference between these two tensions equals the friction between belt and pulley or gives the effective pull on the belt pulley. Let T_1 = tension in tight side, T_2 = tension in slack side, and P = effective pull. It will be seen that the belt must be designed not for the effective pull P , but for the much greater pull or tension T_1 . Hence, knowing the effective pull to be transmitted, the questions of designing the belt and pulley resolves itself into the problem of determining the

relative value of T_1 and T_2 . Ordinarily this ratio is about 2 to 1, and accordingly the belt must be strong enough to stand a tension equal to twice the effective force to be transmitted.

This ratio of 2 to 1 between T_1 and T_2 corresponds approximately to average conditions for friction between belt and pulley, viz.: coefficient of friction = .25 and an arc of contact of 160° .

The ratio of T_1 to T_2 depends upon the coefficient of friction between belt and pulley and upon the arc of contact—the greater the angle of wrap between belt and pulley, the tighter will they grip each other.

The belt formula which is deduced in the last portion of the book has already been explained somewhat in its application to problems in graphical statics of mechanisms. The common shape in which this belt formula is used is,

$$\log \frac{T_1}{T_2} = 2.729 \mu n \quad (5).$$

Prob. 4: A 24" pulley is transmitting 80 h.p. at 200 r. p. m.; arc of contact = 200° ; and coefficient of friction = .3; determine the values of P, T_1 and T_2 .

If the belt runs at a very high rate of speed the belt formula must be modified slightly to allow for centrifugal tension developed in the belt by centrifugal force which diminishes somewhat the effective driving force. For ordinary conditions, however, this effective force may be neglected and the formula as given used for the design. Below a belt speed of 3500 ft. per minute centrifugal force is negligible.

Values of f: According to experiment and observation the value of f , the coefficient of friction, varies from .15 to .56 for leather on cast iron. An average value, consistent with a reasonable amount of slip, belt being in good order, is 0.30. If the belt is oily or greasy or likely to become so, a lower value of f must be chosen. The arc of contact for open belts with pulleys spaced a reasonable distance should be at least 180° . This being the case, it is quite customary where extreme exactness is not desired to assume $T_1 = 2T_2$, which is reasonable, and design accordingly.

The following table gives the value of ratio of the tension

in tight side to the tension in slack side for different arcs of contact and various values of f :

Ratio of Tensions T_1 and T_2

Angle of contact in degrees	$\mu = .2$	$\mu = .3$	$\mu = .4$	$\mu = .5$
40	1.15	1.23	1.32	1.42
60	1.23	1.37	1.52	1.69
80	1.32	1.52	1.75	2.01
100	1.42	1.69	2.01	2.39
120	1.52	1.87	2.31	2.85
140	1.63	2.08	2.66	3.93
160	1.75	2.31	3.07	4.04
180	1.87	2.57	3.51	4.81
200	2.01	2.85	4.04	5.73
220	2.15	3.16	4.65	6.83
270	2.57	4.10	6.59	10.55
300	2.85	4.81	8.12	13.71

Prob. 5: Deduce the tabular values just given by substitution in formula (5) for 160° and $\mu = .3$; also for 200° and $\mu = .4$.

Strength of Leather Belting: The ultimate tensile strength of leather belts is generally taken as 3000 lbs. per sq. in., although some qualities run as high as 5000 lbs. per square inch. The strength at a laced joint is usually about one-third of the strength of the solid leather, and the working stress should be taken at from one-fourth to one-third the strength of the weakest part. This gives about 300 lbs. per square inch of belt section for a laced joint, or about 65 lbs. per inch of width for single thickness belt.

Speed and Horse-power of Belts: The power that can be transmitted by belts increases approximately directly with the speed up to a certain limit, at which the effect of centrifugal force begins to be quite noticeable. Above this speed, the horse-power that the belt can transmit increases, but more slowly, until a critical point is reached where the effect of centrifugal force is increasing so rapidly as to diminish the power of the belt quite materially for any higher speed. The most efficient speed for leather belting is about 4500 ft. per minute.

A very common rule of thumb much used to give the horse-power of belting is the rough approximation that "A single thickness belt 1" wide going 1000 ft. per minute may safely transmit one horse-power." The horse-power that belts are able to transmit varies directly with their width, while the transmitting power of a double belt is to a single belt approximately as 10 is to 7. By tightening up the belt, much more horse-power may be obtained than the rule just quoted gives, but greater friction is produced thereby in the bearings and the life of the belt will be materially shortened.

Prob. 6: A 40" belt pulley is transmitting 30 horse-power at 360 r. p. m. by means of a single thickness belt; how wide should it be by rule of thumb?

Prob. 7: Assuming $T_1 = 2T_2$ and that thickness of single leather belt = $3/16$ ", find the actual working stress per square inch of belt assumed in the rule of thumb.

The r. p. m. of two shafts connected by belts varies approximately inversely as the diameters of their respective pulleys; thus a 60" pulley at 100 r. p. m. driving a second shaft by means of a 15" pulley will give the second shaft

$$\frac{60}{15} \times 100 = 400 \text{ r. p. m.}$$

This is not strictly true because of two reasons which must be taken into consideration where extreme accuracy is required.

First: It is the middle line of the belt that has the same speed as the outside of the pulley rim; and hence twice the half thickness of belt must be added to the actual diameter of each pulley in order to get the effective diameter. Thus, in the illustration just given if belt were $1/4$ " thick, the result would be,

$$\frac{60\frac{1}{4}}{15\frac{1}{4}} \times 100 = 395.1 \text{ r. p. m.}$$

Second: The tension T_1 being much greater than T_2 causes the belt to stretch more on the tight, than it does on the slack side, thus producing what is commonly known as the "creep" of the belt; for paradoxical as it may seem, for every foot of belt that goes on the driving pulley, less than

a foot comes off, just the reverse being true of the driven pulley. The effect of this is to make the rim speed of the driver slightly greater than the rim speed of the driven. The amount of creep varies, but ordinarily the value is not more than one or two per cent., and for all ordinary calculations the effect of both creep and thickness of belt may be neglected in estimating r. p. m. of the pulleys.

Notes and Data for Prob. 8: (Design of a Belt Pulley)—Design and draw a belt pulley to be used with a _____ thickness leather belt, to transmit _____ h.p. at _____ r. p. m., speed of the belt to be _____ feet per minute. Assume arc of contact = _____; and $f =$ _____.

Follow the same method as in your preceding problems. Reserve one page in your note book exclusively for the tabulation of values, making **all** of your numerical calculations on the following pages so that reference can be made to them at any time for the purpose of checking up to discover mistakes.

In this Problem the following symbols will be used. Also tabulate your results in the order now given:

$H =$ h.p. transmitted.	$y =$ thickness of pulley at edge of rim.
$N =$ r. p. m. of belt pulley.	$c =$ thickness of pulley at middle of rim.
$V =$ speed of belt in ft. per min.	$e =$ thickness of arm if continued, to center of wheel.
$D =$ diameter of belt pulley.	$h' =$ breadth of arm at rim.
$R =$ radius of belt pulley.	$e' =$ thickness of arm at rim.
$P =$ effective tractive force in belt.	$z =$ no. of arms.
$b =$ width of belt.	$d =$ diameter of shaft (as calculated).
$B =$ width of pulley face.	$l =$ length of hub.
$t =$ thickness of belt.	$w =$ thickness of metal in hub.
$T_1 =$ tension in tight side of belt.	$k =$ breadth of key.
$T_2 =$ tension in slack side of belt.	$m =$ thickness of key.
$a =$ amount of swelling on crown of pulley.	$d =$ diameter of shaft (corrected).
$h =$ breadth of arm if continued to center of wheel.	

SUGGESTIONS: First, find D from the given data. Then compute P , T_1 and T_2 . Assume safe working tension of belts with laced joints to be 300 lbs. per square inch of belt section. Take thickness of single belts to be $\frac{7}{32}$ ", and that of double belts to be $\frac{3}{8}$ ", and calculate b . In the case of single belts compare this with the result obtained by the use of the rule of thumb.

Pulleys are usually from $\frac{1}{4}$ to $\frac{1}{2}$ inch wider than belt. Assume $\frac{1}{2}$ inch wider. (Note that belts come in standard widths up to 3" by $\frac{1}{4}$ "; from 3" to 6" by $\frac{1}{2}$ ".) Hence, select belt the next standard width greater than calculated value, unless calculated value comes very close to a standard width. Take B to the nearest eighth of an inch. The amount of crown to the pulley should be made greater, the greater the speed at which the pulley runs. The curve may be struck with a radius equal to from $3B$ to $5B$. A tapered face, being more easily produced in some shops, is often used, a taper of $\frac{1}{2}$ " per foot each way from the center being used for pulleys 4" wide and less, while a taper of $\frac{1}{4}$ " per foot is enough for pulley whose width is greater than 4".

The thickness of pulley at edge of rim may be determined by following formula taken from Low and Bevis:

$$y = D/200 + \frac{1}{8}" \text{ for single belts, and}$$

$$y = D/200 + \frac{1}{4}" \text{ for double belts.}$$

The consideration of allowing an easy flow of metal in casting may affect somewhat the thickness as calculated.

Take y to the nearest $\frac{3}{32}$ of an inch.

The inside of the rim of pulley should also be given a taper of $\frac{1}{2}$ " per foot to allow for "draft". Six arms are used in the majority of pulleys of ordinary size. Assume six in your problem if diameter of pulley is 18" or over; less than 18", use four arms. Use elliptical arms; assume $e = .4h$, also $e' = .4h'$. The rim of a pulley being rather light, it is customary to figure the stress on the basis that the entire load is carried by one half of the total number of arms. Treat the arm as a cantilever loaded at the end; and for convenience, figure the size of the arms at the centre of pulley using an allowable fibre stress of 2500 lbs. per sq. inch. Let the arm taper uniformly to rim, making $h' = \frac{2}{3} h$.

Use straight arms in your design. (What is the advantage of using curved arms?)

Calculate diameter of shaft for strength, taking into consideration the bending moment as well as the twisting moment. The simplest way to treat a problem in which there is a combined twisting moment and bending moment is to find the single equivalent twisting moment which would produce the same stress as the combined effect of the other two. The following formula gives this:

$$X_1 = Y + \sqrt{Y^2 + X^2} \quad (6)$$

Where Y = the bending moment, X = twisting moment; and X_1 = effective twisting moment which would produce same stress as the other two combined. To determine the bending moment on the pulley shaft, assume that center of pulley is 10" from middle of journal bearing, and that the bearings are 8 ft. apart, center to center; also figure that there is no danger of bending moment being dangerous on that part of shaft which is reinforced or stiffened by the tight fitting hub; the stiffening effect ceases however within about an half inch of outer edge of hub. This makes two points to figure bending moments for. (See Fig. 50 Instruction Plate No. II.) These two points are at (a) and (b) each of which is $\frac{1}{2}$ " from the end of the hub.

In applying formula (6) use an allowable fiber stress of 7000 lbs. per square inch. Length of hub must be sufficient to prevent rocking on the shaft, and in general must be more for loose pulleys than for tight ones. A good average value is $l = \frac{3}{4}B$.

The hub must be strong enough to carry the key and through it transmit the turning moment to the shaft. It must also be able to take the wedging action of a taper key without splitting. Hub should have a taper of $\frac{1}{2}$ inch per foot for draft similar to inside of rim. Locate key, if possible, underneath an arm. A familiar rule, that the hub should be twice the diameter of shaft gives too small a hub for small shafts and too large a one for large shafts. A good rule given by Low and Bevis in their Machine Design Book is as follows:

$$w = \frac{D}{96} + \frac{d}{8} + \frac{5''}{8}$$

Select keys from standard list of keys for different size shafts, then afterwards check by calculation for the shearing stress in the key used.

To find d_1 , a safe rule is to add $\frac{1}{4}$ " to the calculated diameter of shaft to allow for metal cut out in key way.

NOTES ON GEARING.

Gearing is a general term covering the various methods of communicating motion and power by means of toothed wheels. The relative motion of a pair of properly formed spur gears is equivalent to that of two circular discs revolving about parallel axes; these discs or short cylinders touch on a common point or element which lies in the plane of their axes; and they must have at any time the same linear or circumferential velocity. We have such revolving cylinders in machinery in the form of friction wheels. Such wheels fulfill the requirements of spur gears as long as they roll on each other without slip; and if it were practicable to produce enough friction between such wheels as always to prevent slip, the formation of teeth on the cylinder would be unnecessary.

The gear tooth problem may thus be stated: Having given a pair of cylinders in contact, revolving about parallel axes, to determine the profiles of teeth which being formed on the two wheels, will produce the required relative motion and enable power to be transmitted without slipping. These fundamental cylinders, or as drawn on a plane, circles, are called the Pitch Circles. Hence, the Pitch Circles may be defined as the profiles of the friction wheels to which the spur gear is kinematically equivalent. There are two common systems of tooth profiles; the **cycloidal** and the **involute**.

Curves suitable for gear teeth are called **Odontoids**. When two gears work together a very simple relation connects their diameters and number of revolutions per minute. Let D = diameter of larger wheel, N = its number of revolutions per minute; let d = diameter of small wheel and n = its number of revolutions per minute. Then the number of revolutions per minute of each wheel vary inversely as their diameters, or

$$N : n :: d : D ;$$

so we can easily determine any one of the four when the other three are given. Or putting the same rule in another way, the product of the diameter of the larger wheel by its number of revolutions must equal the product of the diameter of the smaller wheel by its number of revolutions. Thus,

$$N \times D = n \times d.$$

Before taking up the construction of gear teeth or the design of a gear wheel; a summary of definitions will be given:

Definitions: PITCH CIRCLES are the profiles of the original friction wheels to which the spur gears are kinematically equivalent (kinematically = as regards motion alone, without respect to force transmitted.)

CIRCULAR PITCH is the distance from one tooth to the corresponding point on next tooth measured along the pitch circle; or it equals the circumference of the pitch circle \div the number of teeth.

DIAMETRAL PITCH is a ratio and equals the number of teeth per inch of diameter.

SPUR GEARS are the ordinary gears used to connect parallel shafts in the same plane.

BEVEL GEARS are those connecting shafts whose axes are in the same plane, but where the shafts are not parallel. The teeth are on a conical surface; and the apexes of the cones of the two wheels in mesh are at the point where the axes of the two shafts intersect.

MITRE GEARS are a special form of bevel gears in which the two wheels are of equal size and at right angles with each other.

INTERNAL GEARS, or annular gears, are similar to spur gears, except the teeth are on the inside of the rim and point towards the center instead of away from it.

A RACK may be considered as a spur gear of infinite radius. It is simply a series of teeth in a continuous straight line.

ADDENDUM CIRCLE is the circle bounding the teeth at the top.

THE ADDENDUM is the perpendicular distance from the pitch circle to the addendum circle.

DEDENDUM is the depth below the pitch line equal to the addendum of the mating tooth.

ROOT CIRCLE is the circle bounding the teeth at the bottom. The distance from pitch circle to root circle always exceeds the dedendum by an amount called the Clearance.

FACE OF TOOTH is the portion of tooth surface included between pitch circle and addendum circle.

FLANK OF TOOTH is the portion of tooth surface between pitch circle and root circle.

WORKING DEPTH of tooth equal the sum of addendum and dedendum.

BACKLASH: The circular pitch is made up of two parts, the thickness of the tooth, and the space between it and the next tooth. The space is usually larger than the thickness of the tooth by a small amount called the backlash. In finely cut gears, the backlash may be almost nothing.

INVOLUTE: If an inextensible string be unwound from a plane curve and kept taut while unwinding, a pencil point fastened to the end of the string will describe an "involute" of that curve.

CYCLOID is the curve traced by a point in the circumference of a circle as it rolls along a plane curve. If the circle rolls on the top or outside of the plane curve it forms an "Epicycloid"; if on the under side, it forms a "Hypocycloid."

The one great principle or universal law underlying the transmission of power by gearing is "that at any instant the normal to the surfaces in contact must pass through the pitch point."

It is evident that in any ordinary gear the circular pitch should be an aliquot part of the circumference, since there must be a whole number of teeth. This makes the circular pitch a decimal dimension and it has been found more convenient to designate size of teeth by diametral pitch, and they are nearly always now so designated: thus, teeth with number two pitch, means teeth whose diametral pitch is two.

Prob. 9. Methods of Constructing Cycloidal and Involute Teeth: This problem will consist of four parts (a) Construction of cycloidal curve by exact method. (b) Construction of involute curve by exact method. (c) Construction of cycloidal curve by an approximate method. (d) Construction of involute curve by an approximate method.

DATA FOR PART (a): Place a 2" circle on the outside circumference of a 12" pitch circle and another 2" circle on the inside circumference of this pitch circle, so that all three circles touch at a common point p. Roll the outside circle to the right; and the inside circle to the left, each along the circumference of the pitch circle and plot the curve traced by the points in the circumference of the rolling circles that were together at the common point p.

This forms a continuous curve. Show only about 2" of the epicycloidal and 2" of the hypocycloidal curve. (Fig. 12 of Instruction Plate No. 4 will give some suggestions.)

DATA FOR PART (b): Unwind a taut string from a 10" circle and plot about 2" of the involute curve thus made. (For suggestions, see Fig. 13 of Instruction Plate No. 4.)

In both (a) and (b) place on the views sufficient explanations and markings to show exactly how you proceeded.

Both of these exact methods however involve a laborious process, and in actual gear teeth construction only such a small portion of the cycloidal or involute curve is used in forming the tooth profile that an approximation to the exact shape of these curves can easily be made by means of circular arcs. The curves thus formed are so nearly identical with the actual ones as to work satisfactorily and answer all practical purposes; besides of course being much more easily and quickly made.

Approximate Methods of Constructing Gear Curves:

There are a number of approximate methods of constructing either of these two gear curves. One method of constructing a cycloidal tooth is shown in Fig. 14, Instruction Plate No. 5. The radii of the pitch circle and the describing circles are assumed. The diameters fg and ht of the describing circles are then drawn making an angle of 30° with the line of centers. Line mn is drawn through the pitch point p and through the points f and h. As a check it ought to make a 75° angle with the center line. Radial lines are now drawn from center of pitch circle through the points t and g intersecting the mn line at b and c. With b as a center and bh as a radius, strike an arc through h, and this is the hypocycloid or flank of the tooth; then with c as a center and cf as a radius strike an arc through f forming the epicycloid or face of the

tooth. Now to bring these two curves together at a common point and form the entire tooth profile, use is made of the circles of centers. A little reflection will show that circles through b and c will contain the centers of all the arcs that may be used as portions of flank and face of tooth respectively. Thus to draw a complete tooth profile through any point, say the pitch point p , set the compasses at a radius bh and move back along the circle of centers to point b' , and describe the flank of the tooth through p . Then set the compasses to a radius cf and move back along the lower circle of centers to c' , and describe the face of the tooth through p , forming the shaded curve as shown. By a similar method teeth can be formed at any desired point on the circumference of the pitch circle.

The tooth is limited at the top by the addendum circle, whose distance from the pitch circle varies with different gear makers; but the average value of which may be taken as .3 circular pitch. At the bottom the tooth is limited by the root circle, the average value of whose distance from the pitch circle is about .4 circular pitch. Thus it is seen that in any case only a small portion of the cycloidal or involute curve is used as a gear tooth profile, the wheel being made up of a succession of these curves. Thickness of tooth at pitch point depends somewhat upon whether teeth are cast or whether they are cut. In the latter case very little clearance is given. Student may take thickness equal to .48 circular pitch.

An approximate method of constructing an involute tooth is shown in Fig. 15. The pitch circle is drawn with a known radius. Through the pitch point the base line MN is drawn making an angle of 75° with the center line as shown.

The base circle is then drawn tangent to this base line, point of tangency falling at T . Measure up along the center line a distance pb equal to one-tenth the circular pitch; and through b draw a tangent to base circle, point of tangency falling at d ; measure back along db a distance od equal one-fourth db ; and with o as a center and ob as a radius describe the approximate involute curve through b . Note that this curve should be limited at the top by the addendum circle and at the bottom by the base circle; from the base circle to root circle the profile of tooth is a portion of a radial line as indi-

cated. By drawing a circle of centers through o , and proceeding as indicated in Fig. 14, the involute tooth can be constructed at any desired point in the circumference of the pitch circle.

DATA FOR PART (c): Radius of pitch circle = 8", of rolling circle = $1\frac{1}{2}$ ", circular pitch = $1\frac{1}{4}$ ". Construct one complete tooth.

DATA FOR PART (d): Radius of pitch circle = 7", circular pitch = $1\frac{1}{2}$ ". Construct one complete tooth.

Prob. 10. Design of a Spur Gear: To design the larger wheel of a pair of spur gears with _____ teeth and _____ arms, to transmit _____ horse-power; distance between shaft centers = _____ velocity ratio is _____ to _____; pinion to make _____ r. p. m.; permissible working stress in tooth depends on the speed (see Kent P. 903); and breadth of tooth = $2\frac{1}{2}p'$.

Suggestions for Solution: Make all calculations in connection with this design neatly in the note book, first stating clearly all the given data and conditions therein. Make the calculations in regular systematic order. In this plate, the following symbols will be used:—

- | | |
|------------------------------|--------------------------------|
| D = diameter of large wheel. | p' = circular pitch. |
| d = diameter of small wheel | p = diametral pitch. |
| or pinion. | l_1 = addendum of tooth. |
| R = radius of large wheel. | l_2 = depth of tooth between |
| r = radius of pinion. | pitch circle and root |
| N = r. p. m. of large wheel. | circle. |
| n = r. p. m. of pinion. | l = total depth of tooth = |
| Z = No. of teeth in large | $l_1 + l_2$. |
| wheel. | t = thickness of tooth meas- |
| z = No. of teeth in pinion. | ured along pitch circle. |
| H = horse-power transmit- | a = diam. of shaft (as cal- |
| ted. | culated). |
| W = force in lbs. exerted on | b = diam. of shaft (as cor- |
| tooth at pitch line. | rected.) |
| s = permissible working | c = breadth of key. |
| stress per sq. in. of | o = thickness of key. |
| tooth material. | g = length of hub. |
| f = breadth of wheel or | w = thickness of metal |
| tooth. | around eye of wheel. |

j = thickness of feather on arm of wheel.	x = number of arms.
i = thickness of rim.	h = width of arm if continued to center of wheel.
k = thickness of arm (measured parallel to axis.)	v = velocity of pitch point in ft. per minute.

Compute the values of the following and tabulate them in the order given below.

The first eight of these values can readily be obtained from an inspection of the data given you.

(1) D =	(8) s =	(15) l_1 =	(22) e =
(2) R =	(9) W =	(16) l_2 =	(23) g =
(3) d =	(10) p' =	(17) l =	(24) w =
(4) r =	(11) p =	(18) t =	(25) i =
(5) H =	(12) f =	(19) a =	(26) j =
(6) N =	(13) Z =	(20) b =	(27) k =
(7) n =	(14) z =	(21) c =	(28) h =

Determine W from relation between horse-power transmitted, speed of pitch point and pressure exerted on tooth at pitch line.

To determine p' we must investigate the strength of gear teeth. (Read carefully Kent, middle of page 900 to bottom of 901); also the following: As mentioned in Kent, there were a number of different formulas used to determine strength of gear teeth till Mr. Lewis came forward with his formula which took the **shape** of the tooth into consideration, and it is safe to say that this gives the most satisfactory results and is the most widely used formula at the present time. It is desired, however, that the student shall develop and understand the following formula, which was quite universally accepted and employed in the design of gear teeth for a number of years. Old formula for strength of gear teeth:

$$fp' = 16.8 \frac{W}{s} \quad (7).$$

Lewis formula for strength of gear teeth:

$$W = sp'fy \quad (8).$$

In deriving formula (7), several assumptions are made:—

1. Assume that W , the entire pressure, as an extreme

case, might be concentrated at the outer edge of **one** tooth. Note that although this represents an unusual condition, the design must allow for just such contingencies. Ordinarily there will be two or even more teeth in simultaneous contact and the load will be distributed among them; but it is almost certain that at some time, through some cause or other, the proper distribution will not exist, and one tooth will receive all the load.

2. Assume that thickness of tooth at the root (which we will designate m) = $\frac{1}{2}p'$. Note that this is far from being true; in some teeth m greatly exceeds this value and in involute gears with small number of teeth m is **much** less than $\frac{1}{2}p'$.

3. Assume that l equals $.7p'$. (This corresponds quite closely to recognized standard practice.)

4. Then treat the tooth as a cantilever with load on the end. (See Fig. 51, Instruction Plate No. 11.)

From Mechanics of Materials resisting moment equals bending moment or

$$\frac{sI}{c} = Wl \quad (A)$$

from which, by direct substitution of values of I , c and W in terms of breadth of tooth and p' , formula (A), reduces to the shape

$$fp' = 16.8 \frac{W}{s} \quad (7).$$

Each student will be expected to be able to derive formula (7) at any time.

Having found the value of p' from (7), compare it with the value obtain by Lewis formula:

$$W = sp'fy \quad (8).$$

At first sight this equation seems to contain three unknown quantities p' , f and y ; but f may be expressed in terms of p' and this leaves only the two unknown, but even this necessitates the "cut and try" method. Kent, on page 901, gives a table of the values of y for different conditions; or the value of y may be obtained in the case of the 15° involute and cycloidal curve from the following equation:

$$y = 0.124 - \frac{0.684}{N}$$

where $N =$ number of teeth.

As a method of using formula (8) the following is suggested. Knowing the diameter of the wheel, **assume** some diametral pitch, obtaining thereby the corresponding circular pitch and number of teeth from which y is obtained. Then substitute in (8) and solve for W and compare it with the known value of W . If larger or smaller than it should be, make a new assumption as to diametral pitch and try again, until the obtained value of W agrees closely enough with known value. The value of f usually varies from two to four times the circular pitch, depending upon the speed and nature of the gears. The ratio between f and p' is larger for rapidly running gears than it is for the slowly moving ones.

Take f to the nearest eighth of an inch.

The following table for converting circular pitch into diametral pitch is appended for convenience. It is based on the well-known relationship $pp' = \pi$.

The values of l_1 and l_2 differ slightly with the various manufacturers of gear teeth, but the following represents good practice. Make $l_1 =$ reciprocal of the diametral pitch, and $l_2 = 1.157$ divided by diametral pitch.

Table

p	p'
1	3.142
1 1/2	2.094
2	1.57
2 1/4	1.396
2 1/2	1.257
2 3/4	1.142
3	1.047
3 1/2	.898
4	.785
5	.628
6	524

Assume side clearance or back-lash to be $.02 p'$ for cut teeth. In very accurately cut teeth they even assume $t = \frac{1}{2}p'$, while for cast teeth the clearance will sometimes equal $.06p'$.

Use a wrought iron shaft and calculate its diameter for strength by the regular method of determining diameter of a shaft to resist torsion.

The formula takes the shape of resisting moment = twisting moment; or

$$\frac{SJ}{c} = WR,$$

where S is the allowable stress in the shaft = 7000 lbs.; $J =$

polar moment of inertia; and c = distance from neutral axis to most remote fiber.

Select key from standard list of keys (Kent p. 977) using a square key and then check size of key by assuming $g = 5/4 f$ and figuring the actual shearing stress.

A rule for w given in Low and Bevis is,

$$w = .8p' + .02R.$$

For rim of wheel, according to Reuleaux,

$$i = 0.12'' + .4p'.$$

This makes the rim stiff enough so that each arm takes its proportionate share of the tooth load. Assume number of arms as either 4 or 6 according to size of wheel.

Figure the dimensions of the arms as a cantilever with load on the end, each arm taking its proportionate part of the tooth thrust as a load. Assume an allowable fibre stress of 2500 lbs. per sq. inch. If elliptical arms, assume small diameter as .4 of large diameter; for T-arms or cross-shaped arms, consider only the rectangular flange which lies in the plane of rotation as giving the arm its strength; the center leg or feather being used to give lateral stiffness to the arm and to provide in the casting for a free flow of metal between rim and hub. Then assume $h = 4$ or 5 times k , and proceed to find h and k in the same way as for elliptical arm; for convenience imagining the arms continued to center of wheel. For arms, Unwin recommends a taper of $1/32$ on each side.

For some general ideas as to appearance of wheel, method of joining arms to rim, section view of the various shaped arms, etc., reference is made to Figs. 52-56, Instruction Plate No. 11.

Student should make a front view of the entire wheel and a section view through the middle as partly shown in the illustration Fig. 53. Fig. 52 represents a portion of the front view of a gear with cross-shaped arms. Fig. 56 represents a section view through cross-shaped arms. In Fig. 52, note that h is the imaginary width of arm if continued to center of shaft.

Fig. 53 represents a section view of Fig. 52, note that this is a conventional section view and only the rim and hub are shown cut by the section plane. This convention is in very common use.

Fig. 54 shows the section view just as Fig. 53; only in this case the gear has T-shaped arms. Fig. 55 shows the section view for a gear with elliptical arms. In every case the inner edge of the rim has a taper or "draft" to permit of the easy withdrawing of the pattern from the mold.

Question 1. Give two reasons why teeth on pinion would be weaker and more likely to fail than the teeth on large wheel.

Question 2. Having properly designed the teeth on large wheel for strength, what two remedies could you suggest for providing sufficient strength in pinion teeth?

Question 3. If gear wheels were run at a high rate of speed, what alterations or remedies in the design of the gears would you suggest to prevent undue noise?

Prob. 11. Examine the lifting gear of an ordinary coal wagon. Note that usually two chains winding up on a bar transmit the force required to lift the wagon.

(a) Find the diameter of this wrought iron bar if the wagon is capable of carrying 2 tons. Consider the chains to wind on the bar towards the center until they are each one fourth of the distance from the edge of a wagon which is $4\frac{1}{2}$ ft. wide.

(b) Use Kent's hand-book and find proper sized chain to be used.

(c) Allowing for the diameter of chain, find the diameter of the gears and radius of the hand lever, required for one man to raise the wagon. Assume what you consider to be the right efficiency and allow for the weight of the wagon as well as the coal.

Prob. 12. Examine carefully the trains of gears and clutches on the 200,000 lb. Olsen Testing Machine in the Drexel Institute Laboratory. Fig. 57 gives a very elementary sketch of the mechanism (t stands for teeth, and 3 p. i. means 3 threads per inch.)

(a) Find speed of lifting-head in inches per minute with clutch C thrown in, if motor is making 700 r. p. m.

(b) Same thing when the back gears or clutch D is thrown in.

(c) If the beam reads 60,000 lbs. and the back gears are not in, what is the pressure at the pitch line of the 15 tooth

gear A, assuming diameter of A is 4" and considering that the efficiency is 100%? What would the pressure be if the efficiency of the machine between A and the beam were 25%?

(d) Assuming 15% efficiency, what horse-power motor would be required to give the maximum reading on high speed?

Prob. 13. Design of a Bevel gear. The principle of action of bevel gears and spur gears is the same. Indeed, spur gears may be considered a special case of bevel gears in which the axes of the connected shafts intersect at infinity. Let S and S_1 in Fig. 58 be two spur gears connecting the two shafts AA and CC. Prolong the common element of contact between the two spur gears at the pitch point into the line PP. Through the pitch point g, erect normals gf and gt till they intersect the axes AA and CC. These distances gf and gt are radii of the pitch circles upon which the profile of the teeth are constructed in the usual manner and then wrapped back on S and S_1 .

For any other point g_1 or g_2 in the pitch element PP, the same method is followed, but the respective radii would be the same at each position; hence, the teeth are of constant cross-section as we proceed along the axis.

Exactly the same method is followed in laying out bevel gears. Fig. 59 represents two bevel gears B and B_1 connecting axes AA and CC which intersect in the point P. The common element through the pitch point prolongs into PP. Through pitch point g, the lines gf and gt normal to PP and intersected by axes AA and CC, give the radii of the pitch circles upon which the profiles of the teeth are formed, just as in spur gears, and then wrapped back on the bevel gears B and B_1 as shown. For any other point as h in the pitch element, a similar method gives hv and hs as the radii of the new pitch circles. This gives a tooth of diminishing cross section. This last construction is unnecessary. Lines drawn from addendum and root of tooth at g converging to the point P will give the proper shape and size to the entire tooth.

This gives a trapezoidal shape to the root section of the tooth, and a constantly varying value to the circular pitch at different points along the face of the tooth. In figuring

for strength of tooth the average circular pitch is taken as the basis, the strength of the trapezoid being assumed equal to that of a rectangle of same length and whose width is equal to average width of trapezoid. Follow the same general principles of design as used in spur gear, remembering that bevel gears and especially their bearings must be rigid; as any defect in alignment interferes seriously with their proper working. Length of hub should be fully as much as in spur gears to prevent rocking on the shaft and to take care of the end thrust caused by the obliquity of the gear contact. The arms should be especially stiff to strengthen the rim. For that reason a good strong T-shaped arm or else a solid web section is generally employed. The laying out of bevel gears affords a good practice in projection and is a valuable exercise to a designer.

DATA: Design and draw a pair of right angled bevel gears to transmit 12 horse-power at 42 r. p. m. of larger wheel, velocity ratio is 3 to 5 and mean diameter of larger wheel = 15". Draw two views.

Prob. 14. Design of a Worm-gear. Worm gearing is used when a large speed reduction is desired and space is limited. They are always very low in efficiency even when run in oil baths and provided with ball bearings for the end thrust. With single-pitch worm gears, one revolution of the worm rotates the wheel a distance of one tooth, and the number of teeth is usually taken so that whether single or double pitch worm is used; about forty revolutions of worm are necessary for one revolution of wheel. To accomplish this with double pitch worm, 80 teeth would be put on the worm wheel. The pitch and size of teeth is determined by investigating the strength of teeth on the wheel only, the mating worm teeth being amply strong.

It is safe and satisfactory to figure the strength of the teeth just as in a spur gear. In the larger worms, the load is generally distributed between two and even three pairs of teeth.

The teeth on the worm are like the ordinary Acme thread, and a longitudinal section cuts out a rack tooth. This is usually the standard $14\frac{1}{2}^\circ$ (15°) involute form. A very pretty problem in intersection is to pass a plane at right

angles to the worm and then make an end view showing the curve of intersection of this plane with the thread.

DATA: A single pitch worm transmits 6 horse-power to a worm wheel with 42 teeth, value of tooth thrust is 1600 lbs. and allowable fiber stress in tooth = 4800 lbs.; pitch diameter of worm = 4". Find the r. p. m. of both worm and wheel, and design, draw and dimension two views of both. Tabulate values in the usual manner, using symbols for the various parts. Use either elliptical arms in the worm or else join rim and hub with solid web section.

Question 1. The circular pitch of worm teeth are made fractional rather than decimal. Why? (Note that this gives the pitch diameter of the wheel a decimal dimension.)

Question 2. The worm and gear are made of two different materials. Why?

Question 3. Which should be made of the stronger material and why?

Question 4. Which should be made the more accessible and why?

Prob. 15. Notes and Data for Design of Connecting Rod: To design a connecting rod for a ——— x ——— engine, making ——— r. p. m.; steam pressure = ——— lbs.; $l/r =$ ——— Rod is to be forged steel of rectangular cross-section tapering from $6/5$ mean depth at center of crank-pin to $4/5$ mean depth at center of wrist-pin. Draw two complete views and detail the same.

In this Plate, following symbols will be used. Students will compute all these values and tabulate them in the order given below:

l = length of connecting rod.	f = length of wrist-pin.
r = radius of crank circle.	g = diam. of bolts at wrist pin end.
P = total pressure on piston.	e = See Fig. of brasses under suggestion 9.
F = maximum load on rod.	h = width of stub end.
D = diam. of engine cylinder.	i = depth of stub end.
p = steam pressure (gage).	j = corrected length of wrist-pin (if necessary).
t = thickness of rod.	
d = mean depth of rod.	
a = diam. of crank pin.	
b = length of crank pin.	
c = diam. of wrist-pin.	k = width of strap.

m = thickness of strap.	w = distance between bolt centers at crank-pin end.
n = thickness of key.	
o = width of key at top.	x = average breadth of cap
q = length of key.	$= \frac{v + b}{2}$
s = diam. of bolts at crank pin end.	
v = minimum width of cap.	z = thickness of cap.

SUGGESTIONS: 1. Study first the type of connecting rod to be used, especially at the ends where connections are to be made with crank-pin and wrist-pin; and understand thoroughly the nature and use of the various parts of a strap-joint.

2. At the crank-pin end, use marine type of connecting rod in which the cap is held in position by means of two bolts in tension, and wear is taken up by tightening up the nuts.

3. At the wrist-pin end, use a strap joint in which the strap is bolted fast to the stub end of the rod, and wear is taken up by means of a tapered cotter. (See Fig. 61.)

4. Find P, and from this find F by triangle of forces when connecting rod is at the point of maximum angularity.

5. Calculate rod section by means of the following formula from Kent:

$$t = .01D \sqrt{p + 0.6''}$$

Depth of rod at $2/3$ the length from cross-head = $2t$

6. Find diameter of steel crank-pin from following empirical formula:

$$a = .0436 \sqrt{F}$$

Note that this formula will give very satisfactory results for these particular types of engines. (Assume $b = \frac{7}{8} a$.)

7. Assume $f/c = 1.4$ and calculate c, allowing a pressure of 1200 lbs. per square inch of projected area. Why is a formula of this shape suitable for wrist-pin?

8. Assume $2/3 F$ on one leg of strap and calculate diameter of bolt to give shearing stress of 8000 lbs.

9. Compute size of brasses (see Fig. 60 of Instruction Plate No. 12), thus determining stub end proportions and width of strap. See that the sectional area of rod at stub end,

allowing for bolt holes, is at least as much as area of body of rod close to stub end. If it is too small, increase length of wrist-pin slightly.

10. Find thickness of strap, tensile stress allowed = 7000 lbs. per square inch. Assume $\frac{2}{3}$ maximum load on one leg of strap.

11. Assume thickness of key = $\frac{1}{4}$ width of strap; taper = $\frac{1}{16}$. Width of key at small end is same as the thickness. Let small end of key project about $\frac{1}{4}$ " when first put in. Compute all key dimensions.

12. Find s ; tensile stress allowed = 12,000 lbs. per square inch. Assume $\frac{2}{3}$ F on one bolt.

13. Find v . This should be wide enough to accommodate the nut of the bolt. Make it about $\frac{1}{8}$ " greater than the long diameter of the nut.

14. Make w great enough so that bolts may have $\frac{1}{8}$ " to $\frac{3}{16}$ " clearance from lining of babbitt.

15. Compute z for both strength and stiffness using the larger results of the two. $S = 5000$ lbs., $E = 15000000$, allowable deflection = $\frac{1}{100}$ of an inch.

In figuring for strength, it will be noticed that the cap is between the condition of a beam with uniform load and a beam with concentrated load at center. In such cases it is customary to consider that the maximum bending moment = $\frac{1}{6} Wl$, where $W =$ total load and $l =$ length of span.

Some suggestions as to strap connections and design of various parts of rod may be obtained from Fig. 61, Instruction Plate No. 12, which is intended to be merely a suggestive drawing and is not exact.

Question 1. What three things must be considered in design of a crank-pin?

Question 2. What is the effect upon length of connecting rod of tightening up the brasses at the crank-pin end?

Question 3. What is the effect upon length of rod of tightening up the brasses at the wrist-pin end?

Question 4. Why should the end connections be so arranged as to neutralize each other's effect upon the length of the rod?

Question 5. Why is the connecting rod made with the large end at the crank-pin?

Question 6. Why are engine cylinders made with a slight counter-bored portion at each end?

Question 7. If an 18"x20" engine has a piston whose face is 4" wide, what should be the inside length of cylinder from cover to cover?

Supplement Problems: The following supplement problems are given to extend the range of the work and to give facility in applying the formulas through practice. Frequently, the application of formulas to actual problems clears away many obscure points and gives additional confidence to the designer.

Prob. 16: Make a neat sketch of some practical, mechanical arrangement whereby a man by the exertion of a 50 lb. force may be able to raise a weight of exactly 1000 lbs. at least 6 ft. from the ground. Assume what you consider to be a fair efficiency for the device you employ and then dimension your sketch and show by mathematical calculations that it will do the work.

Prob. 17: (a) Prove in gearing that product of $p \times p' = \pi$.

(b) A gear wheel on a certain shaft drives a 16" gear on another shaft at 96 r. p. m. If teeth are number two pitch and distance between shaft centers is 14", find diameter of wheel on first shaft, r. p. m. of first shaft, and number of teeth in each wheel.

Prob. 18: What horse-power engine is necessary to pump water out of a mine 300 ft. deep at the rate of 400 gals. per minute, considering efficiency perfect? What if combined efficiency is 60%? (A gal. of water weighs $8 \frac{1}{3}$ lbs.)

Prob. 19: A 10" gear with 30 teeth on shaft A drives shaft B at 60 r. p. m., a second gear on shaft B drives a 30" gear with 75 teeth on shaft C. If shaft A is making 120 r. p. m., and shaft C is making 36 r. p. m., find:

- (a) No. of teeth in first gear on B.
- (b) Diam. of second gear on B.
- (c) Circular pitch of gear on A.
- (d) Diametral pitch of first gear on B.
- (e) Circular pitch of gear on shaft C.
- (f) Diametral pitch of gear on shaft C.
- (g) Distance between centers of shafts A and B.
- (h) Distance between centers of shaft B and C.

Prob. 20: Prove that in a set of interchangeable gears with cycloidal teeth where the smallest wheel has only twelve teeth that the maximum radius of the describing circle $= 3/p$.

NOTE: The maximum value for the diameter of the describing circle in any case is one-half of the diameter of the smallest pitch circle. The hypocycloidal portion of the tooth then becomes a straight radial line. It is not practicable to have less than twelve or thirteen teeth in a pinion.

Prob. 21: A single pitch worm drives a worm wheel with 40 teeth. On same shaft with worm wheel a 12" spur gear drives a 30" gear, number $1\frac{1}{2}$ pitch, on shaft B. On shaft B is also a drum 24" diameter.

- (a) Find r. p. m. of the drum if the worm makes 40 r. p. m.
- (b) Circular pitch of teeth on 12" gear.
- (c) Diametral pitch of teeth on 30" gear.
- (d) Distance between centers of shaft B and worm wheel shaft.
- (e) No. of teeth in 12" gear.
- (f) Considering efficiency of machine perfect, if a man exerts a force of 50 lbs. on the end of an 18" arm fastened to the worm shaft, what weight could he wind up on the drum?
- (g) What would be the pressure between the teeth of the two spur-gears in (f)?

Prob. 22: Prove that $PR = 63,000 H/N$; where $P =$ effective pull at rim of pulley; $R =$ radius of pulley in inches; $N =$ No. of revolutions per minute, and $H =$ horse-power transmitted.

Prob. 23: An engine, 120 r. p. m., is developing 60 horse-power. An 8' fly wheel on the main shaft is connected by means of a double thickness belt with pulley A on the line shaft. A second pulley on the line shaft drives an 18" pulley on a counter shaft at 480 r. p. m. If line shaft is making 320 r. p. m. and distance between centers of line and counter shaft $= 16$ feet; find:

- (a) Diam. of pulley A on line shaft.
- (b) Diam. of second pulley on line shaft.
- (c) Length of belt needed to connect line and counter-shaft.
- (d) Effective pull on the belt at rim of fly wheel.

Prob. 24: A 24" pulley drives a 20" pulley at 240 r. p. m. If $T_1 = 2 T_2$ and the belt transmits 8 horse-power; find:

- (a) R. p. m. of first pulley.
- (b) Speed of belt in feet per second.
- (c) Effective pull at rim of pulley.
- (d) Width of single thickness belt needed according to rule of thumb.
- (e) Width of belt needed allowing a working stress of 60 lbs. per inch of belt width.

Prob. 25: A 21" pulley making 160 r. p. m. is transmitting 6 horse-power to a 12" pulley by means of a 6" belt.

- (a) Find r. p. m. of 12" pulley.
- (b) Speed of belt in feet per minute.
- (c) Effective pull at rim of pulley.
- (d) Working stress per inch of belt width, if $T_1 = 7/4 T_2$.

Prob. 26: A 20" gear wheel is to be used to transmit 18 h.p. at 60 r. p. m.

- (a) Find force exerted between teeth at pitch point.
- (b) Find diametral pitch of teeth (assuming $f = 3p'$, and using Lewis formula).
- (c) Find circular pitch of teeth by Lewis formula.

Prob. 27: Two parallel shafts 15" apart are to be connected by two gear wheels number 2 pitch and whose velocity ratio is 2 to 1.

- (a) Find diameter of each gear wheel.
- (b) Find number of teeth in each gear wheel.
- (c) Find circular pitch of teeth.

Prob. 28: A motor is to be connected up to the drum of an elevator or hoist. Only one intermediate reduction gearing device may be employed. Make a sketch of the arrangement you would use with all necessary dimensions to show how the desired speed is obtained. Motor is to make 800 r. p. m.; drum to make 12 r. p. m.

NOTE: Limit the size of pulleys and gear wheels so that they will not be abnormal and awkward and neglect slip of the belt.

Prob. 29: A 30" belt pulley, 140 r. p. m. is transmitting 8 horse-power to a 14" pulley on shaft B. From B, the power is transmitted by means of spur gears to shaft C. Shaft C is making 100 r. p. m., distance between shaft centers C and B = 24" and teeth are number $2\frac{1}{2}$ pitch. Find:

- (a) R. p. m. of shaft B.
- (b) Diam. of gear on shaft B.
- (c) Diam. of gear on shaft C.
- (d) No. of teeth in gear on B.
- (e) Circular pitch of gear teeth.
- (f) Value of T_1 and T_2 assuming arc of contact = 160° and coefficient of friction = .35.

Prob. 30: A 6 ft. belt pulley, making 140 r. p. m., transmits 24 h.p. by means of a belt 7 inches wide and .3 of an inch thick to shaft B which is making 288 r p. m. A spur-gear with 40 teeth on shaft B drives shaft C at 384 r. p. m. If distance between centers of shaft B and C = 14 inches, if $T_1 = 9/4 T_2$, and large pulley has 8 elliptical arms; find:

- (a) Speed of belt in feet per second.
- (b) Diam. of gear on B.
- (c) Diam. of pulley on B.
- (d) Diam. of gear on C.
- (e) Circular pitch of gear teeth.
- (f) Effective pull at rim of pulley.
- (g) Value of T_1 .
- (h) Working stress per sq. in. of belt section.
- (i) Dimensions of arms for large pulley if major diameter of ellipse is twice the minor diameter and assuming that one-half of the total number of arms takes the entire load, allowable $S = 2100$ lbs.

Prob. 31: A man exerts a uniform tangential effort of 50 lbs. on the end of an 18 inch crank arm; on this same shaft a 6 inch pinion engages with a 4 ft. spur gear; on same shaft with large spur wheel a double pitch worm drives a worm wheel with 80 teeth. Upon this worm wheel shaft is a 24" drum, on which a weight is being wound.

- (a) Neglecting all friction, what weight can the man raise?
- (b) Assuming efficiency of spur gearing is 90% and efficiency of worm gearing is 70% and neglecting all other friction, what weight could he raise?

Prob. 32: A 20 x 20 engine, 240 r. p. m., is driving shaft B at 320 r. p. m. On shaft B, a 15" spur gear, number 2 pitch, is driving a gear on shaft C at 400 r. p. m. If engine is

transmitting 80 h.p. by means of a double thickness belt $\frac{3}{8}$ " thick and $T_2 = \frac{2}{5} T_1$, find:

- (a) Speed of belt in ft. per second if pulley on B = 4 ft. diam.
- (b) Diam. of main pulley on engine shaft.
- (c) No. of teeth in gear on C.
- (d) Distance between centers of shafts B and C.
- (e) Value of T_1 .
- (f) Value of effective pull at rim of pulley.
- (g) Working stress per sq. in. of belt section if belt is 12" wide.
- (h) Dimensions of one of the 8 elliptical arms for small pulley, allowable fiber stress = 2400 lbs. and assuming small diameter = .4 large diameter.

SPECIAL PROBLEMS

The following special problems are to be worked out and the sketches kept in the note-book, no inked-in drawing to be handed in. The first problem includes two sketches. The first sketch is to be free-hand, merely outlining general shape and appearance of tank, giving the arrangement of openings in tanks, and showing the style of riveted joints, etc. Then, after all calculations have been finished, make a neat lead pencil drawing (two views), showing details where necessary. Dimension this fully and draw it approximately to scale.

Special Prob. A: Design a receiving tank for an air compressor whose length is to be twice its diameter (inside dimensions). Tank to have a capacity of 50.4 lbs. of air at temperature of 72° F., and gage pressure of 150 lbs. per sq. in. Cylindrical portion of tank to be made of one plate with the longitudinal seam a double riveted lap-joint with staggered riveting. Tank to be made complete with provisions for all necessary connections. Use 3" pipes for carrying the air.

Suggestions for Prob. A: Make and arrange all calculations systematically, using following symbols.

- a = cubic ft. of air space necessary.
- b = inside diam. of tank in ft.
- c = length of tank in ft.

d = efficiency of longitudinal joint.

e = thickness of metal used according to standard U. S. gage.

f = diam. of rivets used.

g = stress in metal outside of joint.

h = stress in metal at joint.

i = thickness of reinforcing plate.

j = estimated weight of tank when empty.

k = estimated cost of tank.

Special Prob. B: (See Fig. 62 of Instruction Plate 12.)

Use wrought iron for A, B and C. A is free to rotate on upright C; D is a collar turned on C; B = wrought iron rod. W = ——— and can travel entire length of A. State clearly the allowable working stresses you will employ in tension, compression, etc., and determine the diameter of B; depth and breadth of A; and diameter of C (assuming C is fixed at shoulder D); also thickness of collar D. Systematize calculations as in Prob. A and tabulate data as follows:

a = stress in B.

f = thickness of shoulder on
A about C.

b = diam. of B.

c = width of A.

g = height of shoulder on A
about C.

d = depth of A.

e = diam. of C.

h = thickness of collar D.

Special Prob. C: To design the members of a jib crane in which the height of the mast D = 24 ft.; length of jib B = 40 ft.; and jib is inclined 60° to the horizontal. Crane is carrying a weight of 8 tons suspended by a rope C. Top of jib is joined to top of mast by a tie A.

Find the value of the stresses in each member, state whether they are tensile, compressive, or bending. Select the kind of material you would use for each, and dimension it.

Question: What method could be employed to reduce the high stress in the crane-post or mast D? Tabulate as follows:

a = force in A in pounds.

e = outside diam. of D.

b = force in B in pounds.

f = inside diam. of D.

c = diam. of tie in inches.

g = diam. of rope C.

d = bending moment on D

h = size of B.

in lb. ft.

Special Prob. D: Design a trolley to run on the lower flange of an I-beam, to carry with it a chain hoist for handling a load of 8 net tons, length of span 20 ft.

- (a) Select the proper standard I-beam.
- (b) Select the proper size chain.
- (c) Design and dimension and show by sketches the details of the hoisting arrangement including the hooks of the chain.

Special Prob. E: A small 8" x 10" hoisting engine with a 42" drum geared 5 to 1 is pulling cars weighing 3500 lbs. up a 25 per cent. grade, 2000 ft. long by means of a $\frac{3}{4}$ " cast steel, pliable hoisting rope. Assume that the speed of the cars is 500 ft. per minute and mean effective pressure in engine is 75 lbs. per sq. in. Find:

- (a) Weight of rope used.
- (b) Factor of safety in rope.
- (c) Number of cars engine can haul at one time.

Note that certain general approximations must be made regarding friction, etc., but use correct mathematical principles in determining the result.

Special Prob. F: This consists of a number of separate headings or problems. These problems are of a very miscellaneous character, some pertaining to machine design and strength of materials; others relating to questions of general information. They are partially intended to show the possibilities in the use of a hand book, and to train the student in the art of systematically hunting for information, without loss of time. The answers to all these problems may be obtained directly or indirectly from the Tables in the hand book "Cambria Steel" issued by the Cambria Steel Co. In the solution of these problems, many of which are quite short and simple, it will be found that a number of useful and time saving methods will be acquired.

Prob. 50: (a) A certain rectangular tract of land is 90 yds. x 120 yds., how many square meters does it contain?

(b) The pressure in a certain boiler is 10 kilograms per sq. centimetre; how many lbs. per sq. in. would that be?

In each case determine the result by calculation and then compare with reading from table.

Prob. 51: Define a "nautical mile." How many feet is it equal to? Prove this from the definition.

Prob. 52: The Fahrenheit scale divides the space between the freezing point, 32° , and boiling point, 212° , into one hundred and eighty equal degrees, while the centigrade thermometer divides the space between freezing point, 0° , and boiling, 100° , into 100 equal degrees. The amount of heat that would raise one pound of water six degrees F., would raise it how many degrees C.?

Prob. 53: The amount of heat to raise a pound of water 1° F. is called a British Thermal Unit, while the amount of heat to raise a kilogram of water 1° C. is called a Calorie. The application of 40 calories to one pound of water at 60° F. would raise it to what temperature F.?

Prob. 54: Find the square of: 11.6; 1.89; 77.4; the square root of 64; 1014; 9.86; 10.13; 78.6; 64.5; the cube of 42; 6.28; 10.19; 10.17; the cube root of 7; 696; 10.09; .7854; .112; .16; .49; 1.014; 101.4; 68.57; .001009; .0063; .0814.

Prob. 55: What would be the weight of a cylindrical steel bar $\frac{7}{32}$ " diam. and 40 ft. long, of a bar $7\frac{1}{4}$ " diam. and 20 ft. long, of a bar $11\frac{3}{16}$ " diam. and 20 ft. long, of a bar $19\frac{3}{8}$ " diam. and 10 feet long?

Prob. 56: A sheet of steel, number 000 B. and S. gauge is $4 \times 6\frac{1}{2}$ '. (a) How thick is it? (b) How much does it weigh? (c) What would it weigh if made of copper? of brass?

Prob. 57: Prove that 3.4 times the sectional area of rolled steel sections equals the weight in pounds per lineal foot. In how many different sizes do Standard I-beams come; and show the method of increasing the sectional area of I-beam without increasing the depth?

Prob. 58: What is the safe allowable pressure per sq. in. for ordinary stone? For brick in cement mortar? Determine proper size of steel bearing plate to be used in a wall of good stone masonry to support the end of a 15" standard I-beam weighing 55 lbs. per foot, of 24 foot span, subject to its safe load uniformly distributed.

Prob. 59: Required the safe uniform load for an 18" standard I-beam, 60 lbs. per ft. for a span of 26 ft. without lateral support. (b) How far apart should tie-rods be spaced

for this beam? (c) Find the deflection of a standard 20" I-beam, 70 lbs. per ft. for a 28 ft. span and a maximum safe load uniformly distributed for an allowable fibre stress of 12,500 lbs.

Prob. 60: What is the proper size of I-beam with a clear span of 20 ft. to carry a superimposed load of 21,000 lbs.?

Prob. 61: What is the safe load for a standard 12" I-beam of 30 ft. span, weighing 35 lbs. per ft., the deflection to be such as not to crack a plastered ceiling?

Prob. 62: A standard 7" I-beam, 15 lbs. per ft., 24' span. (a) What is the safe uniform load if supported laterally? (b) How far apart should tie rods be spaced? (c) What is the safe vertical load if unsupported laterally? (d) How much will it deflect in (a)? (e) What is the maximum uniform load if supported laterally that will not crack a plastered ceiling?

Prob. 63: If the span is too long, and the lateral supports are not used, allowance must be made for the failure of beam by buckling of the compression flange. On the other hand, if ratio of length of span to depth of beam is very small the beam will fail by crippling of the web from shearing stresses, though it would still be safe as far as bending moment is concerned. A standard 8" I-beam weighing 18 lbs. per lineal foot with a span of 20 ft. (a) Find maximum total load if supported laterally; (b) Find load if unsupported laterally; (c) Find maximum safe load for any span based upon crippling of the web.

Prob. 64: A 10" standard I-beam, 40 lbs. per lineal foot, with a span of 30 ft. (a) Find safe load if supported laterally. (b) Find safe load if unsupported laterally. (c) What should be length of span under maximum safe load for plastered ceilings? (d) What would be the safe load for plastered ceilings for 30 ft. span? (e) What would be the deflection in (a) if fibre stress were 16,000 lbs? (f) What would be the deflection if fibre stress were 12,500 lbs. per sq. in? (g) What would be the maximum safe load and minimum span for above beam?

Prob. 65: Determine the moments of inertia of the following rectangles placed with their long side perpendicular

to neutral axis: $\frac{7}{16}'' \times 20''$; $\frac{3}{4}'' \times 18''$; $4\frac{1}{2}'' \times 8''$; $3\frac{7}{16}'' \times 28''$.

Prob. 66: A heavy 18" I-beam, 9 ft. long is to be used as a column with fixed ends. What total load will it safely support?

Prob. 67: A hollow round cast iron column with square ends is 12" outside, and $9\frac{1}{2}''$ inside diameter, and is 16 ft. long. What is its total safe load?

PART IV

KINEMATICS

This deals with the motion of the various parts of a machine and embraces some of the most interesting questions in connection with machinery. A few of the principles will be investigated and the application made clear by means of numerous problems.

FUNDAMENTAL DEFINITIONS AND CONCEPTIONS

Motion is a change of position and is measured by the space traversed. Time is involved in the conception.

Relative and Absolute Motion: All known motions are relative. Change of position can only be noted with reference to other objects and since we know of no object in the universe absolutely at rest we have no standard from which to get absolute motion. In ordinary problems in terrestrial mechanics, the earth is taken as the standard from which to reckon, and bodies which do not change their position relative to the earth are said to be at rest, of course recognizing that they really partake of the earth's motion.

Constrained Motion: In a machine, each link has a perfectly determinate motion relative to every link; i. e., its motion is constrained. **Structure:** A structure is an arrangement of material by means of which forces are transmitted, or loads carried without sensible, relative motion of its component parts.

Machine: A machine is a combination of parts so arranged that by their means the mechanical forces of nature can be made to do work accompanied by certain determinate motions.

Mechanism: The term mechanism is often used as synonymous with machine. It is preferable to draw this distinction, however. The machine is expected to do work and must be designed and proportioned accordingly, whereas in a mechanism the relative motion only is considered. A mechanism is a sort of skeleton or kinematic form of machine.

Link: A link is a rigid machine piece connecting two or more elements of different pairs.

Chain: A chain is a series of connected links returning upon itself.

Constrained Chain: A constrained chain is one in which every link has a determinate motion relative to every other link.

A Pair of Machine Elements are reciprocally envelopes of each other, and partly or wholly constrain each other's motion while in contact. There are two kinds of pairs; LOWER PAIRS, having surface contact as shaft and bearing, cross-head and guide, etc.: HIGHER PAIRS, having line contact as cams, gear teeth, etc. Mechanically, lower pairing is preferable as there is less wear.

Figs. 63 and 64 represent chains. The hatching employed in connection with link (a) is merely the conventional method of representing the fixed link. The little circles connecting the various links a, b, c, d, and e are used to indicate turning pairs. It is readily seen that Fig. 63 is not a constrained chain for the links do not have a perfectly determinate relative motion, but by the addition of another link (f) shown in Fig. 64, the chain is at once constrained and the motion of each of the links to every other is perfectly determined.

In a constrained chain the relative motion of the various links is not in the least affected by making each separate link in turn the fixed link; i.e., in Fig. 64 the same relative motion exists between link e and d or between any other two links with (a) fixed as would exist were b, c or any other one of them made the fixed link. From this it follows that a constrained chain can be made into as many separate mechanisms as it has links by making each link successively the fixed link. Such a process is called the Inversion of Mechanisms, and the first problem in Kinematics will be to take the ordinary slider crank mechanism shown in skeleton by Fig.

65, and by successively holding fast the different links a, b, c and d, transform it into four different types of practical steam engines capable of transmitting rotation to a shop shaft.

INVERSIONS OF MECHANISMS.

Suggestions and Helps for Plate I: (Inversion of Mechanisms) 1. Use a full sized sheet of paper 24" x 19" and divide it into four equal spaces reserving one space for each type of engine, drawing to be carefully done in lead pencil and inked if student desires it.

2. Do not go into too many details nor attempt to proportion any of the parts for strength. Represent slides, etc., in a very elementary way; but provide for the free working of the different parts so there shall be no interference, especially of piston with cylinder end; and be careful to preserve the ratio of length of link (b) to (a) equal to 3 : 1. Such detail as steam ports, valves, etc., may be omitted.

3. For the first type of engine, select the ordinary reciprocating engine with which you are familiar having link (d), the cylinder, stationary. It will be noticed that the steam engine, independent of the valve mechanism, is made up of only four parts; link (d), the cylinder and foundations; link (c), the piston; link (b), the connecting rod; and link (a), the crank. Remember that in your inversions the same links must always join each other and by the same kind of pairs: thus, link (b) must always join link (c) with a turning pair; link (c) must always have a sliding contact with (d), etc.

4. The contact surfaces in a lower pair may be multiplied in such way as not to alter the kinematic character of the pair. Thus a simple cylindrically-shaped turning pair may be replaced by any surface of revolution having the same axis. A sliding pair may have any number of contact surfaces provided that these carry parallel rectilinear elements; for instance, the slide (c) of our slider crank is kinematically equivalent to combined piston head, piston rod and cross-head of an engine.

5. In converting this mechanism into engines it will sometimes be desirable to transform a lower pair (without alteration of its kinematic character) by exchanging its solid

and hollow elements. For example, in turning pair shown in Fig. 66 and 67, Instruction Plate 13; kinematically they are identically the same machine. In each case they turn on each other on the same axis AA; the mere interchange of solid and hollow elements has not affected the character of the motion in the least; and if in the Plate on Inversions, it is found convenient, it is perfectly proper to make such an interchange. Likewise the sliding pairs shown in Fig. 68 and 69 are kinematically the same.

6. Balance heavy rotating masses as far as possible. Draw two views of the mechanism in each of the four cases. The most difficult case to realize is "c" fixed, in which case a belt may be added to slider crank; but in all the other cases no extra link is to be added and the machine must be capable of transmitting uniform rotation to a shaft. It may add to the interest to know that inventors and designers have made use of these principles and that all four of these types of engines have been built and used; but the reciprocating type with "d" fixed has proved the most efficient and has come into general use for all purposes. The type of engine with "a" (the crank) fixed has been used quite extensively in various mechanical toys.

INSTANTANEOUS CENTERS

The motion at any instant of a link in a machine, no matter how complicated, is really an infinitesimal rotation about some center or point in the plane of the fixed link. This center is called the instantaneous center. At the next instant, the motion of the link will be around some new center at an infinitesimal distance from the preceding one; and the entire motion of the link will be made up of a series of successive rotations about a number of adjacent centers. The locus of the adjacent centers is called a **Centrode**.

Thus in the slider crank mechanism, Fig. 65, the exact motion of the connecting rod (link b), one end of which moves in the crank pin circle, and the other end in a horizontal direction, can be reproduced by having the rod rotate around a series of centers. For example, in the position of the mechanism represented by the figure, produce the center

line of the crank indefinitely, and erect a perpendicular to the motion of the piston at the point where connecting rod joins it, then will the intersection of these two lines (call it x) be a point in the fixed plane of the engine cylinder, about which, at this instant, the connecting rod is turning.

Proof: To show that the connecting rod is actually rotating around the point x at this instant, viz., to prove that it is the instantaneous center:

The actual motion of the crank end of the connecting rod is along the tangent pt to the crank circle, and the actual motion of the piston end of the connecting rod is along the horizontal line fg . If it can be shown that a rotation of the connecting rod at this instant about the point x gives the rod exactly the same motion it has by virtue of its connection with crank and piston, the proof is complete. Now the motion at any instant of any point in a rigid body that is rotating around a center, must be normal to the radial line, joining the point and that center; hence if the rod were rotating about x , the motion of the crank end would be normal to the instantaneous radius xp ; and the motion of the piston end of the rod would be normal to the instantaneous radius xf ; but remembering that xp is a prolongation of the center line of the crank and that xf is perpendicular to the stroke line, it follows at once that normals to these two lines agree exactly with the actual motion of the two ends of the rod, and hence the point x , as located, is the **instantaneous center**. A general rule for locating the instantaneous center of a link therefore is as follows: "**Erect normals to the paths of motion of any two points in the given link and their intersection will be the center required.**" From the properties of the instantaneous center, it follows that if the velocity of motion of **one** point in the link is known, then the velocity and direction of motion of **any** part of the link can be determined. **Rule:** The direction of motion of any point in the link will be normal to the instantaneous radius at that point, and the velocities of different points will be directly proportional to their instantaneous radii.

PROBLEMS IN INSTANTANEOUS CENTERS AND DISPLACEMENTS.

The following problems are to be done neatly in ink on a small sized sheet of regular kinematic paper. Put down carefully the data, the necessary explanations, and the tabulation of results on each plate, so that to the examiner it will be evident from your plate what was given, how it was solved, and the result.

Prob. A: Draw the slider-crank mechanism of Fig. 65 with crank in the 30° position. Make the length of crank 1", use ratio of 3 to 1 for connecting rod and crank, and provide against interference of working parts.

Given: Crank pin has a uniform velocity of 8 ft. per second.

(a) Find velocity of piston in this crank position.

(b) Also find direction and velocity of motion of center of connecting rod.

(c) Find some position of crank where piston is moving faster than crank pin.

SUGGESTIONS: Place the drawing at the bottom of the sheet, to allow room for construction and explanation. The piston has the same motion as the point f of the connecting rod, and the crank pin has the same motion as the other end of the connecting rod; hence all the questions may be solved by means of the instantaneous center of the connecting rod.

Problem B: Consider the arrangement of levers shown in Fig. 70, which is a sort of variable motion mechanism. Link 2 is moved by handle H, which is secured to the same shaft, and thus H and 2 really form one piece. By proportioning and arranging the levers differently, various kinds of motions can be produced. Links 4 and 2 may be made to rotate in the same or in opposite directions; a complete rotation of 2 may produce a complete rotation of 4 or just an oscillation of 4 between limits, or an oscillation of 2 may produce a complete rotation of 4. All these various motions may be produced by varying the length and positions of the relative links.

DATA: Figure similar to Fig. 70; center I2 is 3" to the right of, and 1" above center I4. Handle H is twice as

long as lever 2 and is 90° in advance of it. Lever 2 is $\frac{3}{4}$ " long and is 15° above its extreme right-hand horizontal position; rod 3 is $3\frac{3}{4}$ " long; and link 4 is $1\frac{1}{8}$ " long and is just a little to the left of its upright vertical position. A constant tangential force of 50 pounds is applied at the end of the handle H producing counter-clockwise rotation. Neglect friction.

(a) In the given position, what force will link 3 be capable of exerting at the point where it joins 4?

(b) When lever 2 has moved up to its vertical position, what force could it exert on 4?

(c) In the position first given, what is the direction of motion of center of link 3?

(d) Suppose in first position, that end of handle H was moving at the rate of 10 inches per second, what would be the velocity of end of lever 4?

(e) Beginning with 2 in position given in (b) and using the circumference of the circle described by end of 2 as a base line plot vertical ordinates showing the speed of the point 34 at the various points in the rotation of 2, and then plot a curve through the ends of these ordinates, assuming that end of handle H was moving at a uniform speed of 10" per second. (Use separate sheet of paper for this.)

SUGGESTIONS: Without friction the same amount of work is being done at every point in the machine; hence if the speed is greater at one point than another then the force exerted will be proportionally less; by principle of moments determine the force exerted at 23, and then find the instantaneous center of link 3.

Problem C: Fig. 71 represents a toggle-joint mechanism, which is a modification of the mechanism of Problem B, and is used a great deal in presses, shearing and crushing machinery. It will be noticed that the more nearly the links 2 and 3 flatten out into a straight line, the more powerful the thrust R becomes.

DATA: Links 2 and 3 are each $1\frac{1}{2}$ inches long. Assume no friction.

(a) If the mechanism is in a position where 2 and 3 each make angles of 30° with the horizontal, and the end of link

2 has a constant velocity of 4" per second, what is the velocity of link 4?

(b) What if the mechanism is in position where the links each make an angle of 10° with the horizontal?

(c) If in this latter position, a tangential force F of 1200 lbs. is applied as shown, use a graphical method entirely and find value of R .

(d) Same as (c); find R by a combination of principle of moments and graphics.

(e) Same as (c); find R by means of instantaneous center relations.

(f) Beginning with 2 in the 90° position, plot a curve showing the varying value of R as 2 descends to the horizontal position. (Use separate sheet of paper for this.)

The next two problems do not bear directly upon instantaneous centers, but are concerned with questions of motion, as applied to indicator work. In an indicator it is absolutely necessary that the pencil point shall have exactly a true perpendicular motion. The most natural and easy way to test for this would be to put the paper on the drum, draw the horizontal atmosphere line, and then lift the pencil arm, tracing the path of the pencil; take the paper off the drum and examine it to see if line is exactly perpendicular. But in case we had merely a design of the indicator and wished to find out if such an arrangement of links and levers would give a perpendicular motion without actually constructing the apparatus, we would have to test it by means of a drawing.

Problem D: Fig. 72 represents a skeleton drawing of this Thompson Indicator with the critical dimensions as obtained from a blue-print kindly furnished by the manufacturers for that purpose. Re-draw this one and a half times full size. Then cause pencil arm to move, and locate at least four new positions of pencil point and test for perpendicularity of motion.

NOTE: An indicator is only designed to give perpendicular motion within certain limiting positions of pencil arm, so do not attempt to raise pencil arm too high; also pay no attention to the rotation of the paper drum, as that is a separate problem.

Problem E: Same data as in Problem D. But in this

case hold the pencil arm stationary and cause the remainder of mechanism to swing around it, noticing the various points in the plane of the indicator which pass beneath the pencil point. Test for perpendicularity of motion as in Problem D.

A MORE GENERAL DISCUSSION OF INSTANTANEOUS CENTERS.

Hitherto in our treatment of instantaneous centers, we have been considering only the one instantaneous center for a given link; for instance, in the slider-crank mechanism (see Fig. 65) we spoke of the instantaneous center of link 3 as being a point in the fixed plane of 1, around which, at this instant, link 3 was turning. This center is designated I_3 . Now if we imagine an indefinite plane attached to each of the four links of this mechanism, then link 3 will have the additional instantaneous centers 2_3 and 4_3 ; i.e., points in the moving planes of 2 and 4 respectively, about which, at this instant, link 3 is turning. Likewise, link 2 possesses the instantaneous centers 2_1 , 2_3 and 2_4 , being points in the plane of 1, 3 and 4, about which, at this instant, link 2 may be conceived as turning. Similarly every link of any mechanism will have as many instantaneous centers as there $(n-1)$ links in the mechanism.

Considering link 3 again; of its three centers, I_3 , 2_3 and 4_3 , the center I_3 is more useful in solving questions concerning the velocity of link 3 than either of the others, because it is a point in the fixed link, whereas the points 2_3 and 4_3 , though they are centers of rotation at this instant for link 3, are situated in planes themselves that are moving. But there is another conception or definition of instantaneous center which makes these other centers useful also in answering questions concerning the motion of the various links.

New Definition: The conception or definition that we have been using of any instantaneous center, say 2_3 , was the point in plane of 2, around which link 3 is turning, or vice versa, the point in plane of 3 around which link 2 is turning. The new conception or definition of an instantaneous center is, "That particular pair of coincident points in the plane of each which at this instant have exactly the same velocity

both in amount and direction." Thus the instantaneous center 23 is that particular point in plane of 2, which at this instant has the same motion exactly as the corresponding point in the plane of 3.

Method of Locating the Instantaneous Centers:

(a) Any mechanism will have as many instantaneous centers as there are permutations of its links taken two and two; thus, a four-link mechanism made up of links 1, 2, 3 and 4 will have the following instantaneous centers 12, 13, 14, 23, 24 and 34.

(b) The axes of all turning pairs are centers. Sliding pairs have their centers at infinity, in a direction normal to their relative paths of motion.

(c) A very convenient way to arrange all the possible centers is the "combination table." Take, for instance, a six-link mechanism, then the combination table would be as follows:

		12			
		13	23		
Combination Table		14	24	34	
		15	25	35	45
		16	26	36	46
					56

(d) In determining the instantaneous centers of any mechanism, first write the combination table and enclose all the known centers with a circle; then proceed to locate the remaining ones by means of the "Theorem of Three Centers."

Theorem of Three Centers: "The three instantaneous centers of any three separate pieces having determinate motion lie in the same straight line." Thus consider a machine, and take any three of its links, say 2, 3 and 5; then the three instantaneous centers 23, 25 and 35 must lie in the same straight line. This fact is very useful in locating the various instantaneous centers of a machine.

Proof of Theorem of Three Centers: Take any mechanism, say a 6-link mechanism, and let us consider the three links 1, 2 and 3. Then the three instantaneous centers of these three links are 12, 13 and 23; and we are to prove that they must lie in a straight line. Assume the three centers (see Fig. 73) and mark them 12, 13 and 23. Then by the new definition 23 is a point in plane of 2 which at this instant has exactly the

same motion as the coincident point of plane 3. But according to the old definition every point in plane of 2 is moving around center I_2 . Let the infinitesimally small arc aa represent this path of motion. Also every point in plane of 3 is moving around center I_3 , and let the arc bb represent this path of motion. But since 23 is a point in both 2 and 3 which is moving in the same direction, the infinitesimal paths of motion aa and bb must coincide; but coincidence of aa and bb requires coincidence of their normals; hence I_2 , I_3 and 23 must lie in a straight line.

Apply the principle of the Theorem of Three Centers to the solution of the following problems:

Problem F: Locate all the instantaneous centers of the six links mechanism (copies of which will be furnished you at the proper time).

Problem G: Draw the slider-crank mechanism and locate all six of its instantaneous centers. Crank = 1" long, placed in its 45° position, ratio of connecting rod to crank = 3 to 1, crank-pin has a uniform velocity of 10 ft. per second.

(a) Find the velocity of piston in the given crank position by two methods. The student will already be familiar from a preceding problem with one method of finding the piston's velocity. The other method is based upon this new definition of instantaneous center. The results of the two methods of course should agree.

Problem H: Draw a skeleton of the Thompson Indicator same scale as before. Number the links, 1, 2, 3, 4, etc., calling the fixed link 1 and then locate all the instantaneous centers. By means of these determine whether pencil point P has perpendicular motion at this instant; also determine the relative velocity between motion of point P and that of the indicator piston. Notice the importance of this last relation between proportionality of motion of indicator piston and pencil point in the usefulness of an indicator.

Relation Between Angular Velocities of any Three Pieces: Suppose it is desired to find the relation between the angular velocities of 2 to 1 and angular velocities of 3 to 1. Let av stand for angular velocity then av_{21} reads "angular velocity of 2 to 1."

SOLUTION: Reference to Fig. 73. Since by definition the

linear velocities of the coinciding points in the plane of 2 and 3 which are together at 23 are the same; and since 2 is revolving around 12, and 3 around 13, it follows directly that the angular velocities vary inversely as their distance from the centers around which they are turning, thus,

$$av_{21} : av_{31} :: \text{distance } 23-13 : \text{distance } 23-12.$$

Hence in comparing the angular velocities of any two links, say 4 and 5, what is needed is the third link 1, and the three instantaneous centers 14, 15 and 45; then just as from the preceding it follows that

$$av_{41} : av_{51} :: 45-15 : 45-14. \quad (10)$$

which is perfectly general in its application. Not only can the relative value of the angular velocities be determined, but also their relative directions.

Rule: "If the distances 45—15 and 45—14 in formula (10), are measured in the same direction, then the angular velocities of 4 to 1 and 5 to 1 are alike; if they are measured in opposite directions, they are unlike. Reference to Fig. 73 will make this clear. Distances 23-12 and 23-13 are measured in the same direction and it is evident from the figure that coincidence of arcs aa and bb both in position and direction as shown by the arrows, requires that both 2 and 3 should be rotating clockwise around their respective centers 12 and 13; but Fig. 74 shows a new position of 12 which also causes the arcs aa and bb to agree in position and direction; but the distance 23-12 and 23-13 are now measured in opposite directions which gives by our rule unlike rotation, and it is also just as evident from Fig. 74 that in order for aa and bb to agree in direction as well as position that 3 must have clockwise rotation around 13, while 2 must have counterclock rotation around 12.

Problem I: Use Fig. 75 which represents one of the linkages taken from Plate I in Graphical Statics of Mechanism. Link 4 is moving clockwise to 1 as shown by arrow, hence av_{14} is counterclock. Determine whether angle between 3 and 4 is opening or closing; also determine the relative angular velocity of 3 to 4 as compared with 1 to 4.

Problem J: Determine in the "Blake Stone Crusher," Plate V of Graphical Statics of Mechanism, whether angle between 2 and 3 is opening or closing.

Problem K: In the geared windlass of Plate III of Graphical Statics, locate the various instantaneous centers and determine by kinematic principles and measurements the pull P , necessary without friction for the given load.

Problem L: Use plate in Graphical Statics which contains the shaper, and draw skeleton of same on small sheet of white paper, as follows:

(1) Place center (12) 3" from right hand edge, and $4\frac{1}{2}$ " from bottom of sheet.

(2) Center 14 is $2\frac{3}{8}$ " above center 12.

(3) Distance from center 12 to stroke line of 6 = $5\frac{3}{16}$ "

(4) Crank 4 is inclined to the right at an angle of 30° with the horizontal.

(5) Length of link 2 = $5\frac{1}{4}$ " : of link 5 = $2\frac{5}{16}$ "

(6) Length of link 6 = 4".

(7) Length of crank 4 = $15/16$ ".

(a) Make out a combination table and locate all the instantaneous centers.

(b) Find velocity of tool at this point in stroke if 4 is rotating uniformly with a velocity of 8" per second.

(c) A tangential force of 100 lbs. on end of crank 4 would produce what force at the cutting tool?

(d) Determine by means of angular velocity relation whether angle between 2 and 5 is opening or closing.

PLATE II—CENTRODE CONSTRUCTION

For this problem, use a full sized sheet of regular manilla paper 24" x 18". Divide it vertically by pencil into three equal spaces, and the middle one of these three, horizontally into two equal spaces, making four altogether. In each space draw a skeleton outline of the slider-crank mechanism, making each link successively the fixed link just as in the plate of Inversions. Omit all the detail of the plate on inversions using the simple skeleton as shown in Fig. 65 for each case.

Assume connecting rod equals three times the length of the crank and make crank equal $1\frac{1}{4}$ ". In the first large space, make the cylinder the fixed link and proceed to find the fixed centrode of connecting rod, i.e., the locus of its instantaneous centers in the plane of the fixed link for the entire motion of

the rod. Then in each of the other spaces find the fixed centrode for that particular link which does not touch the fixed link. Reserve the case of link *b* (the connecting rod) fixed for the last large space. It will be well to get a few suggestions as to the proper position to locate each slider crank mechanism before beginning to draw. After drawing the fixed centrode, locate the **moving centrode**, which may be defined as, "The locus of the points in the plane of the moving link which successively coincide with, or roll on the fixed centrode while the mechanism is going through its regular motion."

CENTER OF ACCELERATION

Just as the instantaneous center is a center of velocity, by means of which the amount and direction of the velocities of the different links or points in the links of a machine may be determined, so also there may be located by graphical methods a center of acceleration by means of which the amount and direction of the acceleration of any point in a given link may be read off directly. Space will not permit of the treatment of this phase of the subject in this book, but the attention of the student is called to the existence of the center of acceleration and of the possibilities arising from it. A graphical construction for determining the acceleration of the reciprocating parts of an engine is taken up and thoroughly studied in connection with the course in Steam Engines. This forms one of the most common and important cases of acceleration which occurs in engineering practice.

CAM DESIGN

It is frequently necessary to give certain parts of a machine a very irregular and sometimes peculiar motion from a uniformly and regularly moving source of driving power. To do this, a cam is generally used; and hence it is essential that every engineer should have some knowledge of the design or laying out of cams. A thorough understanding of the principles employed in the following problems should enable the engineer to handle satisfactorily any ordinary cam problem that may arise. Cam design is really a special problem in displacements; i.e., the ability to locate the position

of the various links of mechanism after a certain amount of motion has taken place.

Definitions: A cam is a turning or sliding piece, which by the shape of its curved edge or a groove in its surface, imparts a variable or intermittent motion to a roller, lever, rod or other moving part. The part in immediate contact with the cam and driven by it is called the "**follower.**" Cams are distinguished as positive motion cams and non-positive motion cams. A **positive cam** is one which is so constructed as to compel the driven piece at all times to move in a certain definite manner. It so surrounds the driven piece that it cannot get away and must follow the motion of the cam. Nothing short of actual breakage of some of its parts can prevent it from imparting the desired motion to its driven link. It will drive in either direction. On the other hand, **non-positive** motion cams depend for their perfect operation upon the raising or lowering of a weight (i.e., gravity or the action of a spring). The first two cams given in following problems are examples of non-positive cams. Non-positive cams, though extensively used, are of a lower order of mechanical excellence than the positive; and other things being equal a positive cam should be chosen, as a non-positive one will refuse to work if the weights or part operated by a spring should get caught.

The following cam problems are to be done on regular Kinematic paper. The illustrations used in Problems M, N and O were taken from one of the text books of the International Correspondence School, of Scranton, by their kind permission.

Problem M: (See Fig. 76.) To design a cam of such an outline that as it revolves uniformly right handed, it will, during the first half of every revolution, cause the end of the rod R to drop uniformly downwards $\frac{3}{4}$ ", during the next quarter remain stationary, and during the last quarter of its revolution cause the end of the rod R to move uniformly up to its original position.

SUGGESTIONS: There are several ways it can be done. One of the simplest and best is based upon the following. (Use this method.) It makes no difference with the relative motion of the links as to which is made the fixed link of the

mechanism. Thus instead of having the cam to rotate clockwise, hold the cam stationary and cause the lever L and the frame work to rotate to the left around B as a center, being careful in this inversion not to change the fundamental conditions; i.e., the fixed end of lever L always remains a fixed distance from center B. Then the outline of the cam must be made such that it will cause the given rise and fall of the roller A during this rotation.

NOTE: Locate the path followed by the center of the roller A first, then by means of this plot the outline of the cam; also make the roller A as small as practicable and save material in the cam as far as possible.

Graphical Methods of Laying Off Harmonic Motion and Uniformly Accelerated Motion: To lay off a uniform motion along a line by dividing the total distance up into a number of equal parts to represent the distance traveled in each element of time is so self-evident as not to require explanation.

HARMONIC MOTION: To lay off harmonic motion (see Fig. 77). Suppose it is desired to represent distance traversed in the six equal elements of time while going from M to N by harmonic motion. Upon MN as a diameter construct a semi-circle and divide it into six equal parts. From each point of division erect perpendiculars 1a, 2b, etc., to the diameter. Then the resulting distances Ma, ab, bc, etc., represent harmonic motion from M to N. Definition: "Harmonic motion then may be defined as the motion upon the diameter executed by the foot of a perpendicular let fall from a body moving uniformly in a circle."

UNIFORM ACCELERATION: Suppose it is desired to represent distance traversed in three equal elements of time while going from G to H, starting from rest at G and uniformly accelerating to H (Fig. 78.) Lay off a base line ad and divide it into 3 equal parts. Draw any slant line ag and erect perpendiculars be, cf, dg. Then the areas included between the bounding lines in each interval of time represent the space traversed. These areas are seen to be in the proportion of 1, 3 and 5. Therefore add 1, 3 and 5 together, giving 9. Divide the line GH into nine equal parts; then the distances Gh, hi, and iH as laid off in Figure represent the distances traversed in each of the three equal intervals of time.

Problem N: To design a cam C of such a nature that while rotating uniformly right handed it will cause roller A and rod R to rise with a uniform motion to a distance of $1\frac{1}{4}$ " during $\frac{2}{3}$ of a revolution, then to drop at once to its original position and to remain there during the remainder of the revolution. (Fig. 79)

SUGGESTIONS: Prolong the center line of R and draw a circle with center at B tangent to this center line of R. Lay off from A a distance $1\frac{1}{4}$ " vertically up along center line of R. Then with B as a center describe a circle going through this point $1\frac{1}{4}$ " above A. Divide the circle into 12 equal parts and proceed as before to revolve the rod around the stationary cam C, and plot a curve fulfilling the conditions of the problem.

Problem O: (See Fig. 80.) This is a positive motion cam; the cylinder D has a groove cut around it, in which the roller A of rod R moves. R is pivoted at O and transmits a vibratory motion to F while the cylinder D revolves uniformly. Problem is to design the cam of such a nature that during one-half of the revolution of cylinder the rod F is to vibrate $\frac{3}{8}$ " to the left and back once, and that during the other half it is not to move. Vibration of rod F to be harmonic motion.

Problem P: Design the following cam for an alligator shear (See Fig. 81). Cam shaft is to have a uniform rotation, cutting edge of shear opens while cam turns $\frac{1}{4}$ revolution, remains full open during $\frac{1}{6}$ of revolution, and closes during the remainder. The character of the motion is as follows: If the time of one revolution be divided into 24 equal parts, then the jaw rises with a uniform acceleration during three periods is uniformly retarded during the next three, remains stationary as above mentioned; then in the descent is uniformly accelerated for first three, moves uniformly during next eight and uniformly retarded to the lowest point in the next three periods. Total rise of jaw from 3° below its horizontal to 15° above, or 18° total rise.

The proof that the cycloidal and involute curves are correct curves to use for gear teeth profiles, and the derivation of the common belt formulas are herewith appended, with the belief that all who have the slight knowledge of mathematics and calculus necessary to follow the reasoning will be greatly

helped by following through these demonstrations; and anyone who has occasion to work out problems in design of either belts or gearing will certainly have more confidence in himself and a greater satisfaction in his work when the fundamental principles and theory underlying the design are perfectly understood.

A—PROOF THAT CYCLOIDAL AND INVOLUTE CURVES ARE CORRECT CURVES FOR GEAR TOOTH PROFILES

I. **Cycloidal:** Fig. 84. Let ACE and BCF be the two friction discs upon which it is desired to form teeth that will roll on each other smoothly and transmit to each wheel exactly the same motion as is transmitted when these two friction discs roll on each other without slip. Let DCG be the auxiliary rolling or describing circle. These three circles all touch at the common point C. Now suppose these three circles to revolve about their respective axes, A, B and D, so as to roll on each other at C without slip; and imagine a pencil point fixed at any point p in the circumference of DCG, and pieces of paper fastened to the planes of ACE and BCF. Let the three points p , a and b be together at C. It is evident that as the circles revolve in the direction of the arrows, the describing point p will describe a curve on disc ACE, and at the same time another curve on the paper projecting beyond the disc BCF, these two curves being respectively pa and pb . (It must be noted here clearly that these curves pa and pb , formed by having all three discs rotate on their axes, are exactly the same two curves we would get when the three points p , a and b were together at c , if we held the two discs stationary and rolled the describing circle DCG on the inside of ACE tracing pa , then came back and rolled the describing circle on the outside of BCF tracing pb . This latter method is the one used in laying out teeth on the drawing board; but the curves pa and pb formed in either case are identical.) Returning to the curves pa and pb , they were formed by a common point p while the wheels were rotating properly; conversely if teeth or curves of the shape pa and

pb were formed on these wheels and allowed to roll on each other, they must necessarily impart to the wheels the proper motion, and therefore these cycloidal curves are correct curves for tooth profiles. The important fact is that every point in pa has a corresponding point in pb that was traced at the same time by a common point p, hence these curves have continuous contact.

To generate a complete tooth curve a second describing circle HCK opposite the first is necessary. It is not essential that DCG and HCK be equal, but it is obvious that the face of one tooth and the flank of its mating tooth must be formed with the same sized describing circle.

II. *Involute*: Fig. 85. Here again we have two pitch circles, ACG and BCF. Through the pitch point C, draw a line HK making with AB an angle $\text{ACH} = \text{BCK}$ usually 75° , then draw the secondary or base circles BE and AD tangent to HK. Consider HK as part of a cord that is wrapped around each base circle and connecting them. Let p, a and b all be together at C and then have the pitch and base circles rotate on their axes without slip in direction indicated by arrows, the point p tracing a curve pa on the plane of the upper pitch circle and at the same time another curve pb on the plane produced, of the lower pitch circle. (Here again the curves pa and pb are exactly the same as would be described by the end of a string if it were unwound from these base circles while they were held stationary, which is the method used in laying out involute teeth.) Just as in the preceding case, then, the curves pa and pb have continuous contact, being traced by a common point p while the wheels were rotating properly without slip; therefore if curves of this shape are placed on the circumference of these wheels, and the curves compelled to roll on each other, they must give the wheels exactly the same motion which the wheels had when the curves were generated; i.e., a correct motion. Hence, the involute curve is also a correct curve for a gear tooth profile. It will be seen from this construction that an involute curve only extends to the base circle; below the base circle the profile of an involute tooth is part of a radial line to the center of the wheel.

B—DERIVATION OF THE BELT FORMULA.

Consider first a very small portion of the belt as shown in Fig. 86. This is held in equilibrium by the three forces P, Q and R, where P and Q are the two belt tensions in this small portion of the belt and R is the normal reaction. Let α = small angle aoc expressed in radians. If we take it very small $R = P \alpha$ (see force triangle); but friction = coefficient of friction multiplied by normal pressure, therefore we have

$$\text{Friction} = \mu R = \mu P \alpha = P - Q \quad (\text{a})$$

where μ = coefficient of friction. If we let θ represent the entire angle of wrap in radians, then if $P - Q$ is made indefinitely small

$$\alpha = d\theta; \text{ and } P - Q = dP.$$

Substitute these values in (a) and we have

$$dP = \mu P d\theta, \text{ or } \frac{dP}{P} = \mu d\theta \quad (\text{b}).$$

By integration,

$$\begin{aligned} \log_e P &= \mu\theta, + c; \text{ or} \\ P &= e^{\mu\theta} \times e^c \quad (\text{d}) \end{aligned}$$

where e = base of Nap. logs. Find value of c by noting that when $\theta = \text{zero}$, then $P = Q$; hence since under those conditions $e^{\mu\theta} = 1$, we find $e^c = Q$.

Substitute this value in (d), we have

$$\begin{aligned} P &= e^{\mu\theta} \times Q \text{ or} \\ \frac{P}{Q} &= e^{\mu\theta} \quad (\text{f}). \end{aligned}$$

Now substituting the symbols generally used; viz.: T_1 = tension in tight side, and T_2 = tension in slack side, formula (f) reduces to

$$\frac{T_1}{T_2} = e^{\mu\theta} \quad (\text{g}).$$

To reduce formula (g) to the shape in which the belt formula is commonly applied, remember that modulus of common logarithms = .4343; and letting n represent the

angle of wrap in fractions of a turn or circumference, we have by direct substitution in (g)

$$\log \frac{T_1}{T_2} = 2.729 \mu n \quad (5)$$

which is the shape in which the belt formula is commonly given.

Prob 100: If a 4' pulley is transmitting 20 h.p. at 240 r p. m., and the coefficient of friction is .33, and it is desired to have $T_2 = 3/7$ of T_1 , find:

- (a) Value of P, T_1 and T_2 .
- (b) Necessary arc of contact or angle of wrap.
- (c) Width of double thickness belt needed allowing 400 lbs. per sq. in. of belt section.

KEY TO CRITICISMS.

The following system of indicating corrections of the Drawing Plates will be used. In each case the criticism or mark will be placed near the line or dimension to be corrected, and the student must, in every case, make the correction thus indicated and return the plate.

Note—Do not erase or disturb the mark or sign used by the instructor in making his criticism.

- | | |
|---|---|
| <i>a.</i> Not laid off accurately. | <i>k.</i> Similar lines should have the same thickness. |
| <i>b.</i> Wrong kind of line. | <i>l.</i> Section lines uneven and not spaced properly. |
| <i>c.</i> Line not uniform. | <i>m.</i> Dots uneven in length and spacing. Make them as near 1-16 inch as possible. |
| <i>d.</i> Detail is incomplete. | <i>n.</i> Arrow heads poorly formed. |
| <i>e.</i> Excess of dimensions on a standard article. | <i>o.</i> Section lines should not cut through dimension figures. |
| <i>f.</i> Not properly dimensioned. | <i>p.</i> View not placed properly. |
| <i>g.</i> Needs an overall dimension. | <i>q.</i> Use one style of lettering. |
| <i>h.</i> Centre line missing. | |
| <i>i.</i> Line apparently drawn free-hand. | |
| <i>j.</i> Shaded incorrectly. | |

SAMPLE STYLE OF LETTERING.

A line drawn through a letter or figure means that it is incorrectly formed. The example given below shows proper style of letters and figures to be used.

a b c d e f g h i j k l m n o p q r s t u v w x y z
A B C D E F G H I J K L M N O P Q R S T
U V W X Y Z. 1 2 3 4 5 6 7 8 9 10.

VARIOUS STANDARD LINES.

- A* ————— Visible lines ; a good, firm line.
B - - - - - Invisible lines ; dots of equal length and equally spaced.
C ————— Shade lines ; two or three times thickness of (*A*).
D - — — — — Center lines ; dot and dash lines.
E ———— Dimension lines ; broken where dimension is inserted.
F ————— Extension lines ; a fine solid line.



Cast Iron.



Wrot Iron.



Mall Iron



Cast Steel.

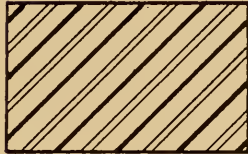

Wrot Steel.



Nickel Steel



Brass.



Copper.

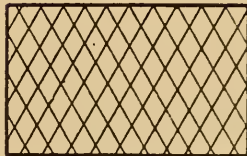

White Metal.



Stone.

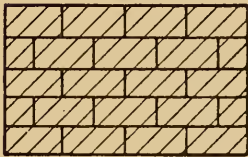

Brick.



Cement.

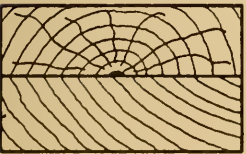

Wood

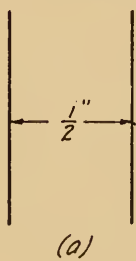

(a)

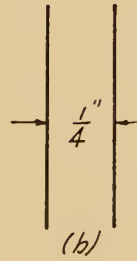

(b)

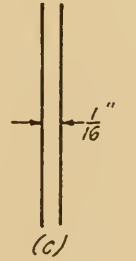

(c)

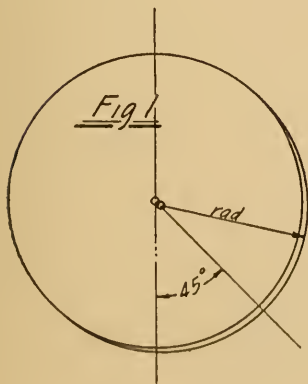

Fig 1

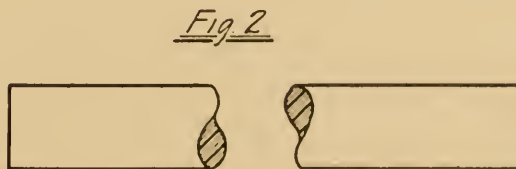

Fig 2

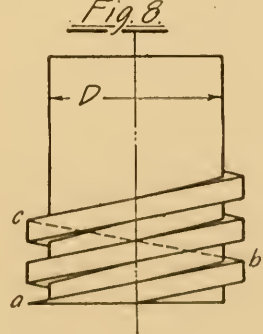
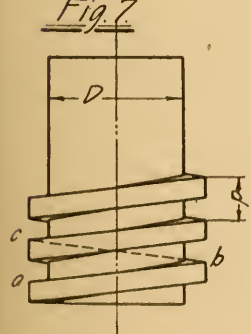
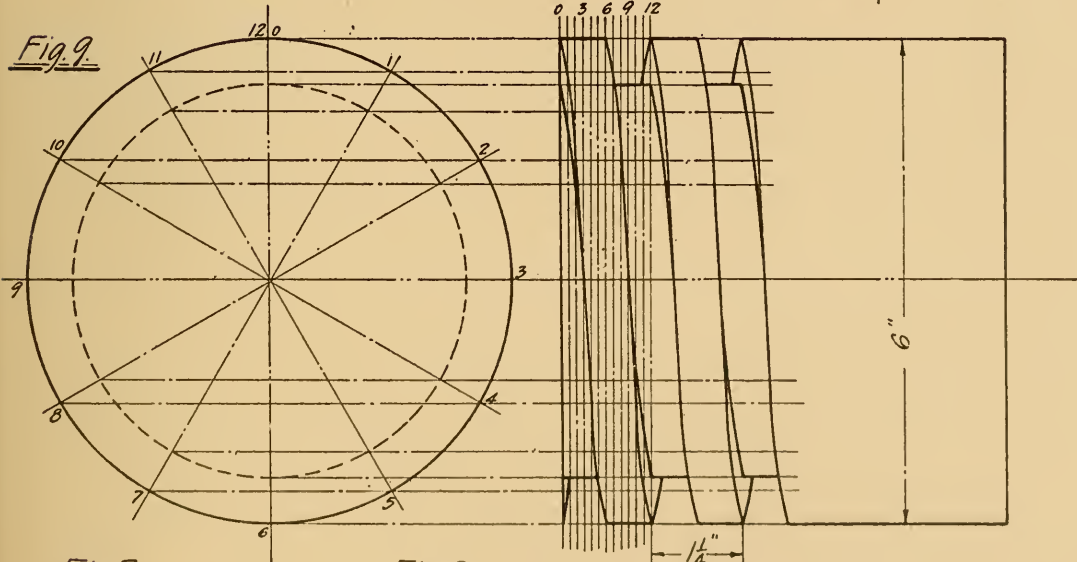
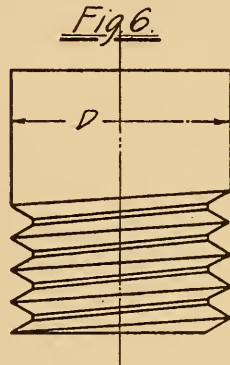
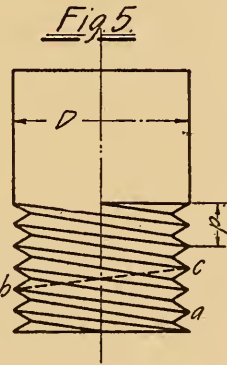
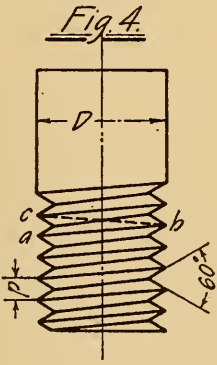
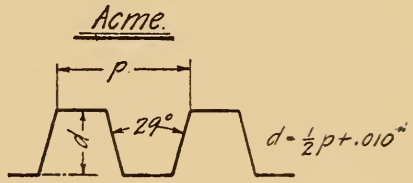
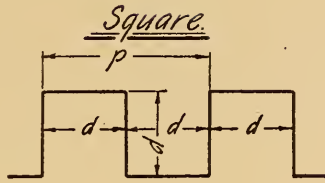
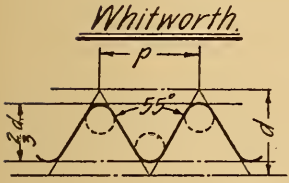
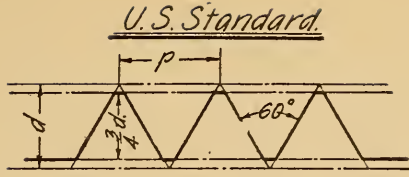
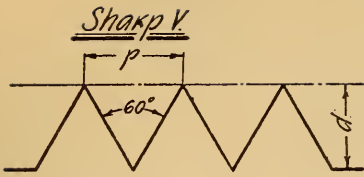

Fig. 10

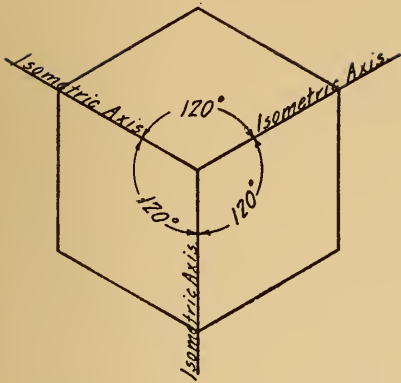
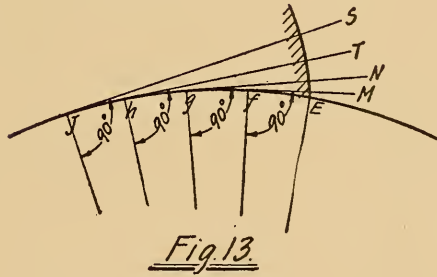
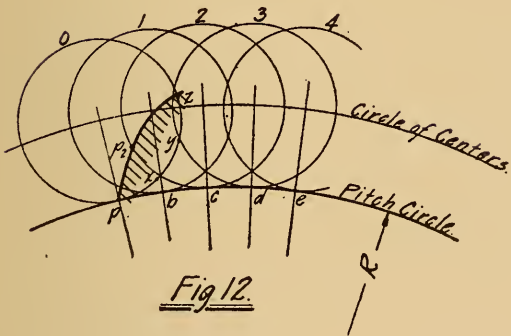
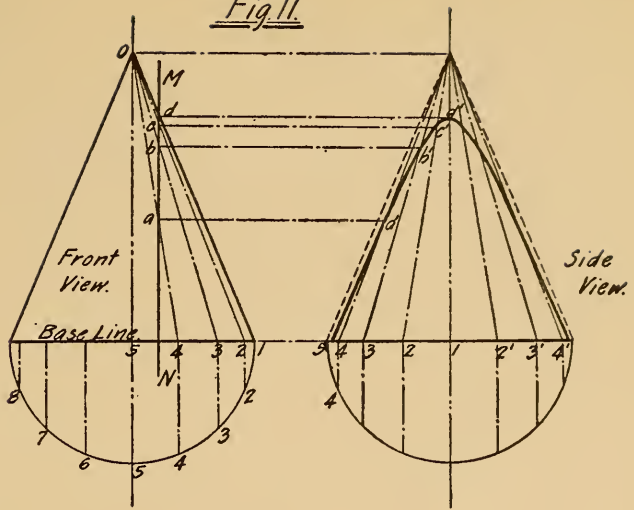
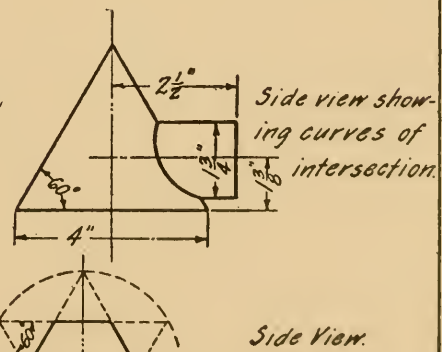
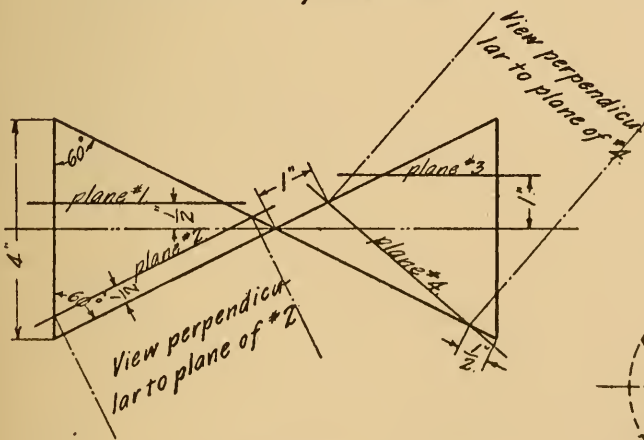

Fig. 11



Top view of cones showing intersections of planes #1 and #3.

Top view showing curves of intersection of cone and cylinder.



Bottom view showing intersections of planes #2 and #4.

4" sphere cut by 6 planes. Bottom View.

Title Plate-IX

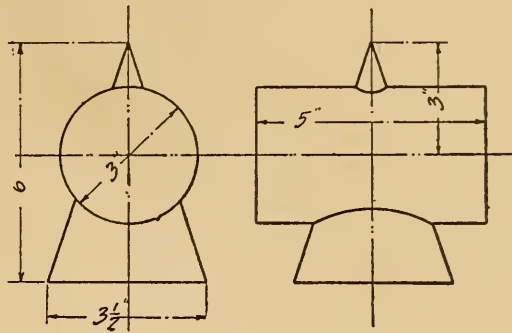
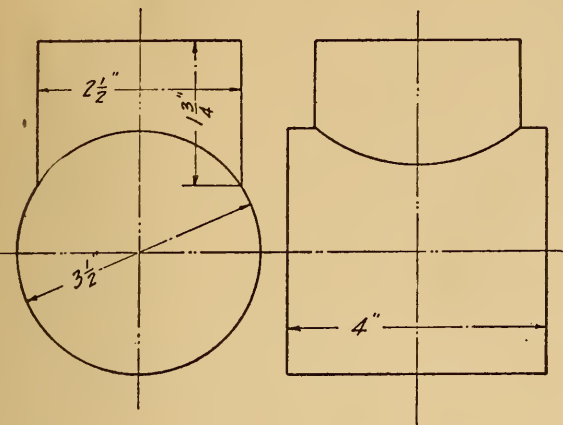

Place here
top view of above.

Place here a development of the
larger cylinder.

Place here a development of
Cone showing Intersection.

Place here a development of the
smaller cylinder.

Title
Plate X.

Fig. 14.

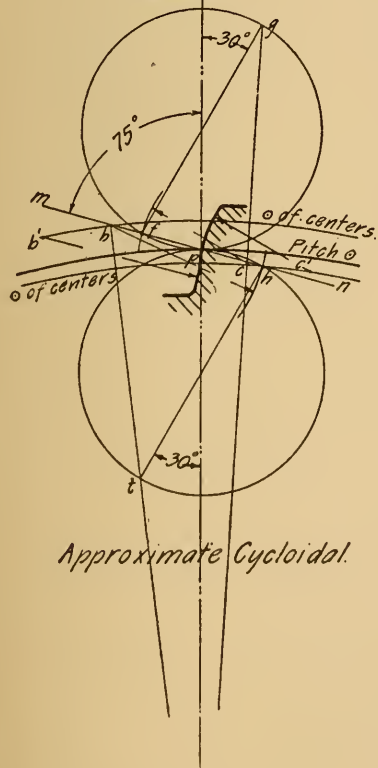

Approximate Cycloidal.

Fig. 15.

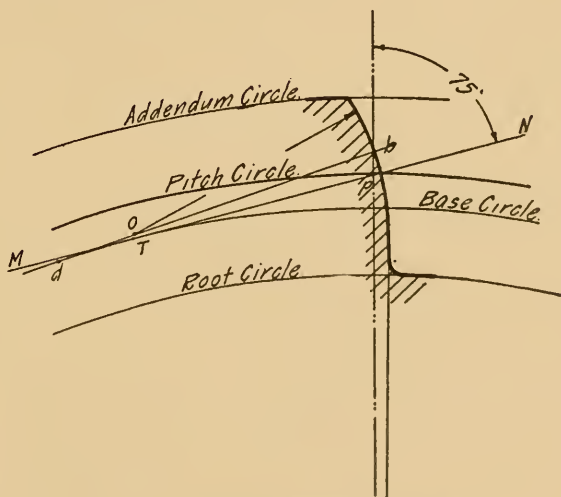

Approximate Involute.

Fig. 16

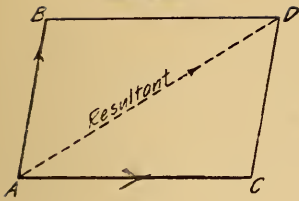

Fig. 17a

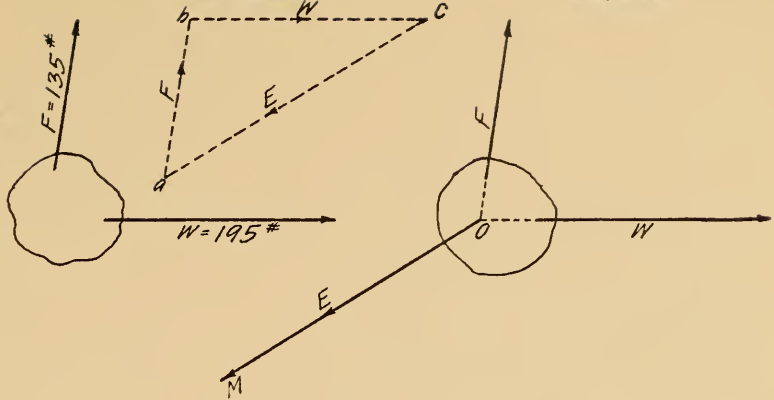

Fig. 17b

Fig. 18a

Fig. 18b

Fig. 18c

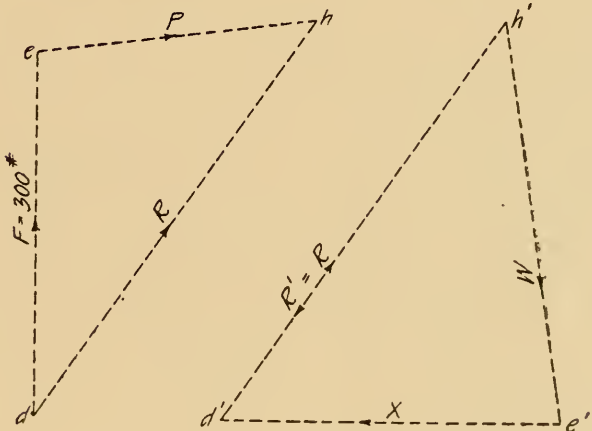
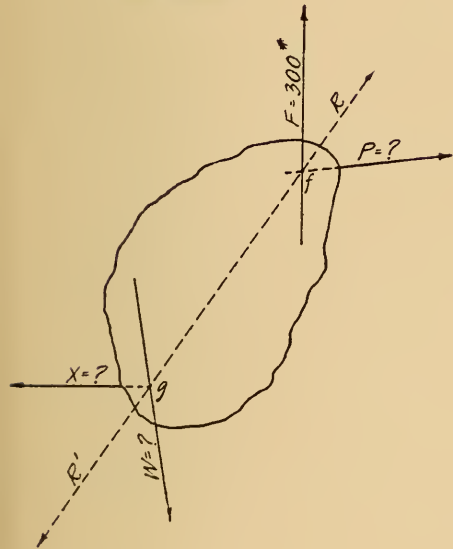

Fig. 19a

Fig. 19b

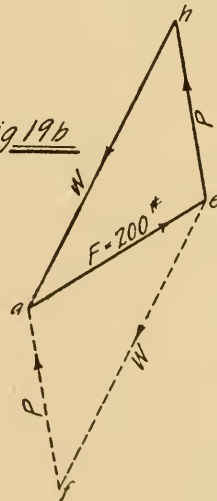
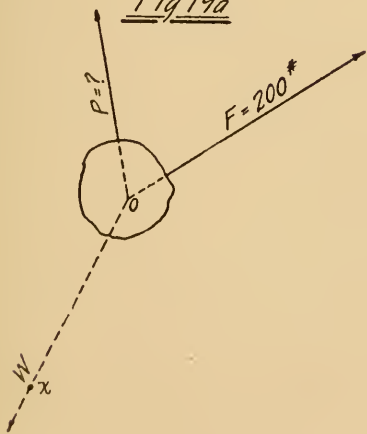

Fig. 20

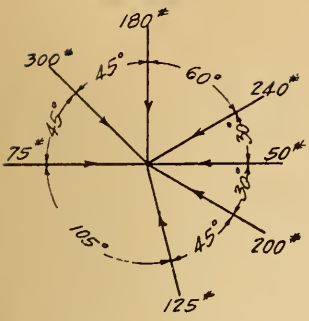

Fig. 21

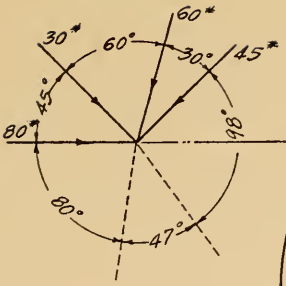

Fig. 22

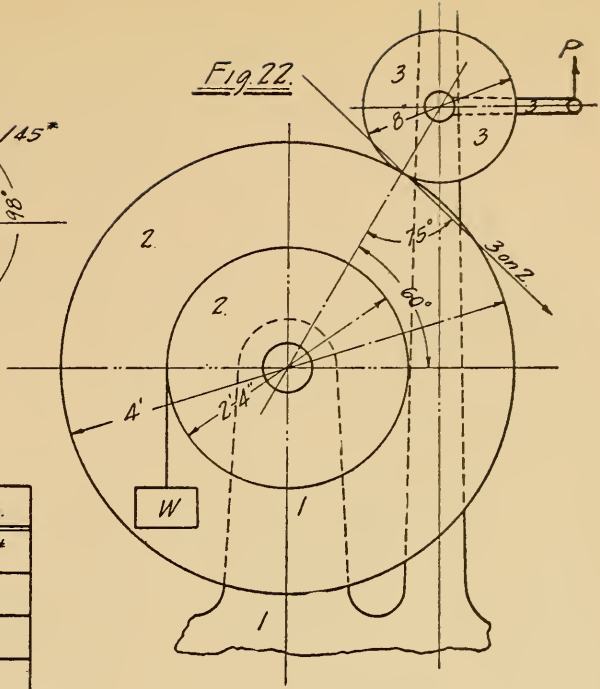

Fig. 23

Force.	Value.
W	900*
2 on 1	
3 on 2	
3 on 1.	
P	

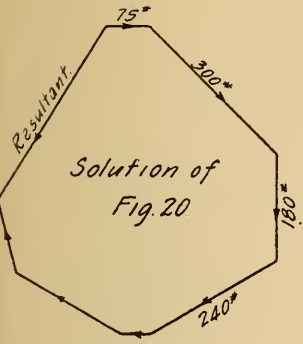

Fig. 24

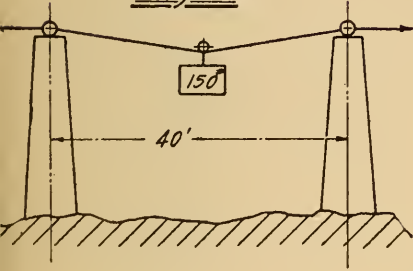

Fig. 25

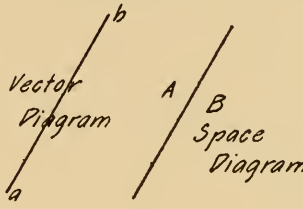

Fig. 26

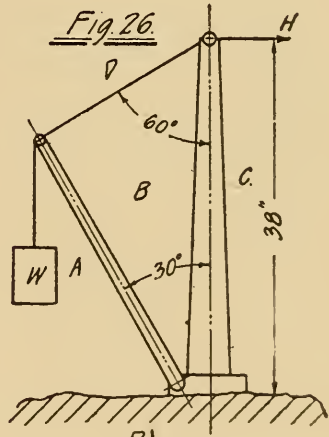

Fig. 27

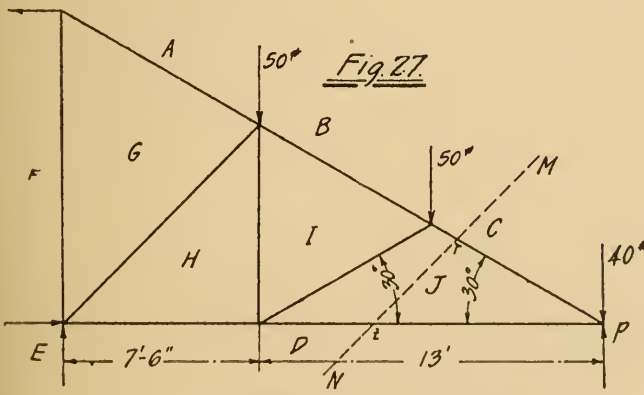

Fig. 29

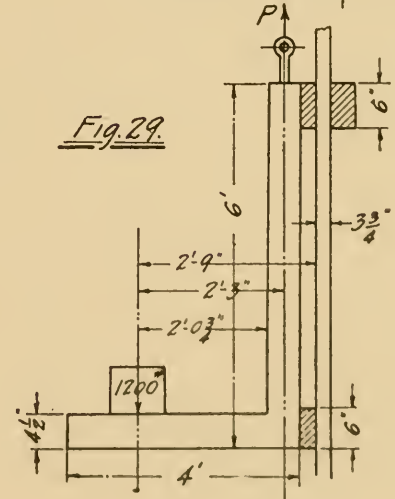

Fig. 28

Force.	Sign.	Value.
AB	+	50*

Fig 37

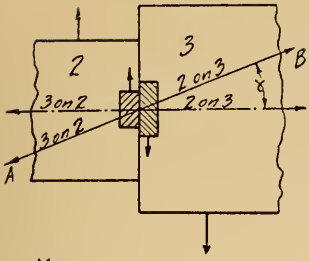

Fig 38

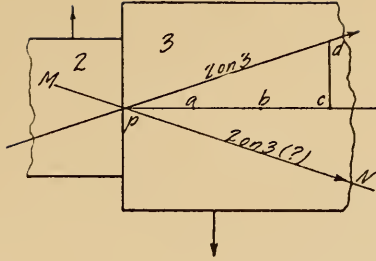

Fig 39

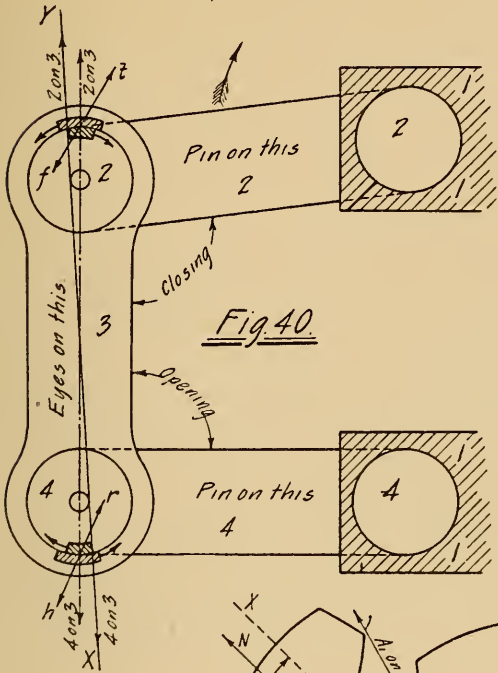
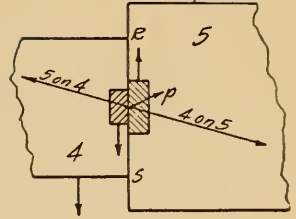

Fig 41

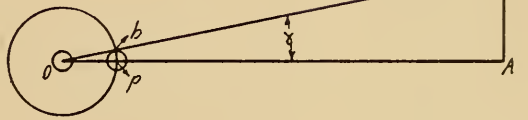
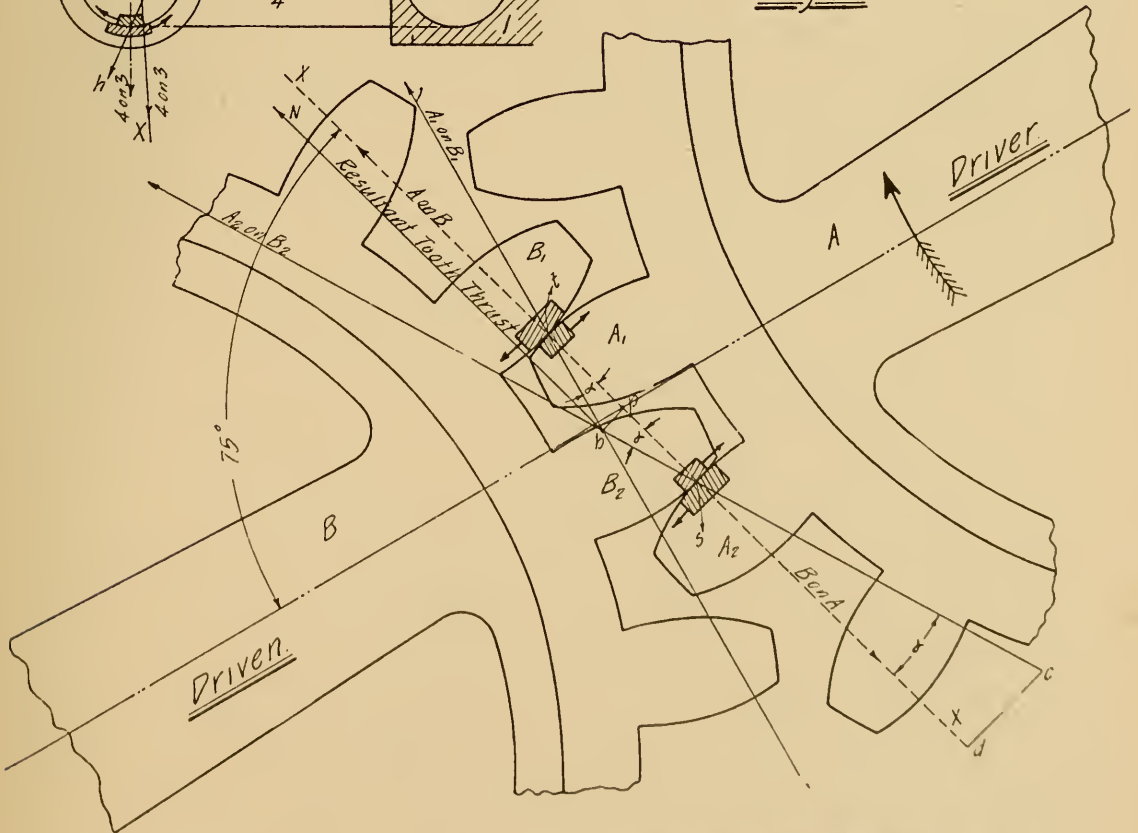

Fig 42



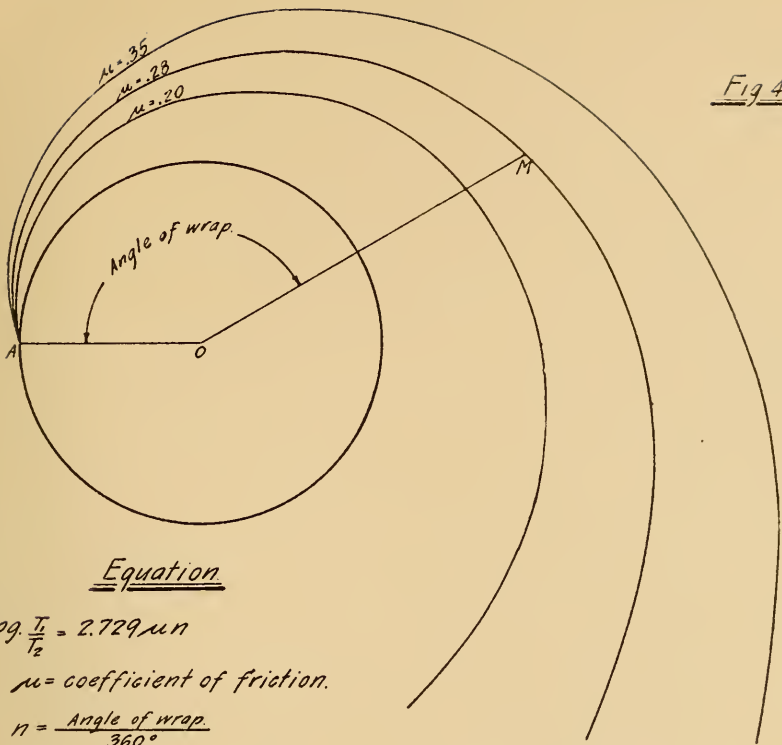

Fig 43

Equation

$$\log \frac{T_1}{T_2} = 2.729 \mu n$$

μ = coefficient of friction.

$n = \frac{\text{Angle of wrap}}{360^\circ}$

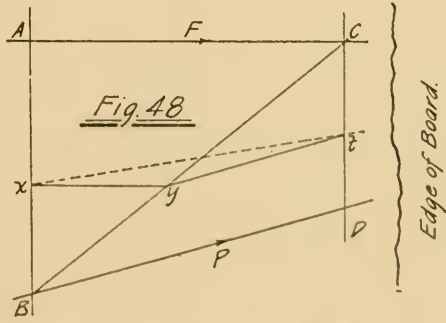
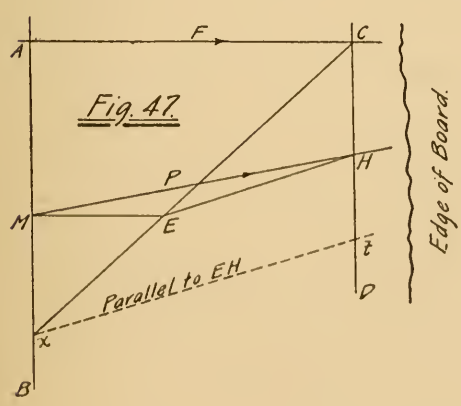
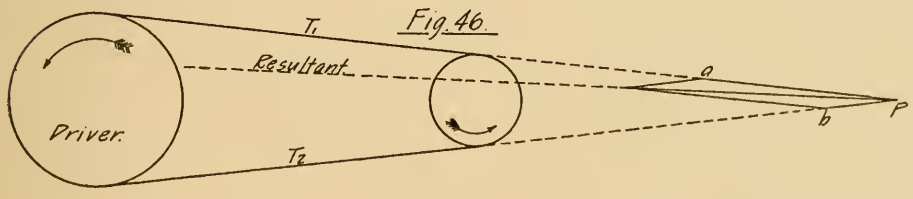
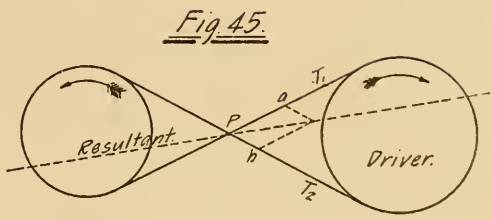
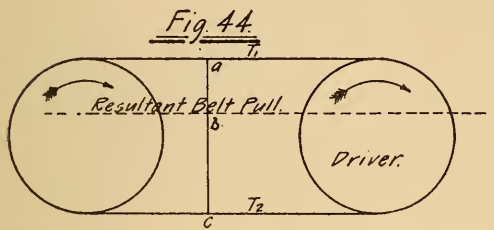

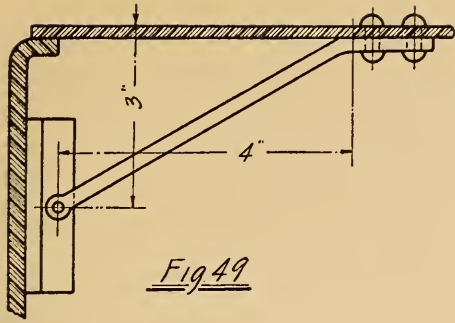

Fig. 49

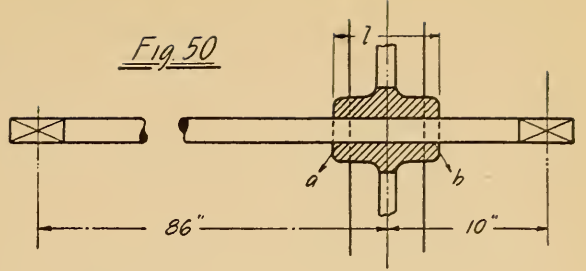

Fig. 50

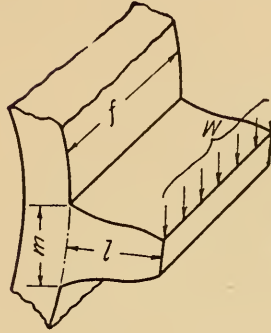

Fig. 51

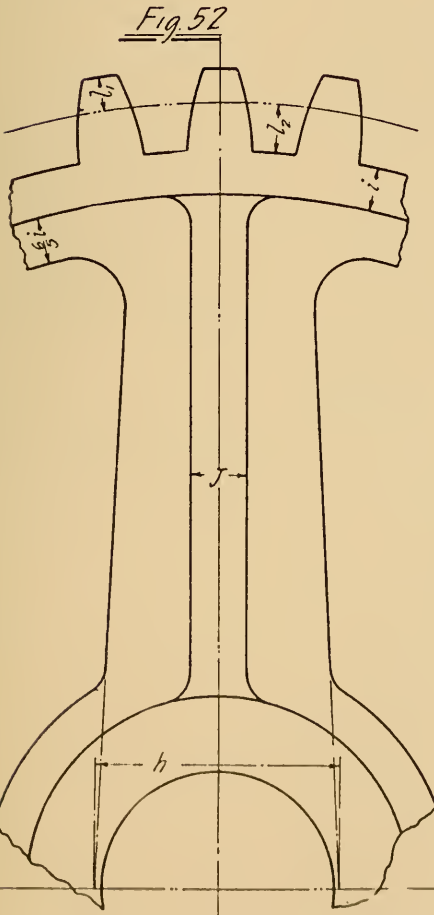

Fig. 52

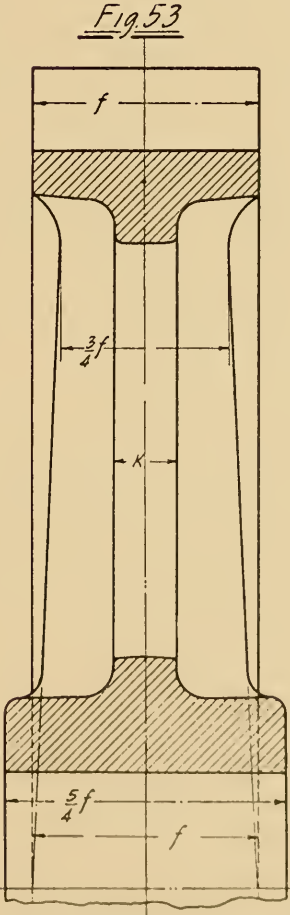

Fig. 53

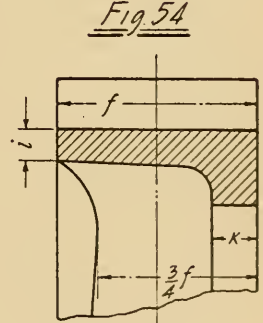

Fig. 54

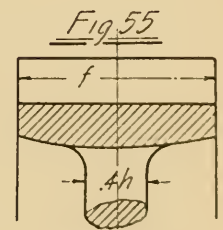

Fig. 55

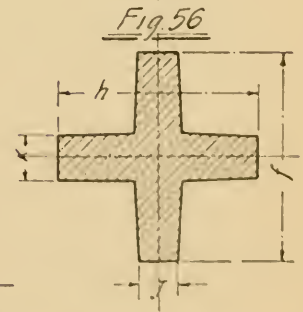

Fig. 56

Fig. 57

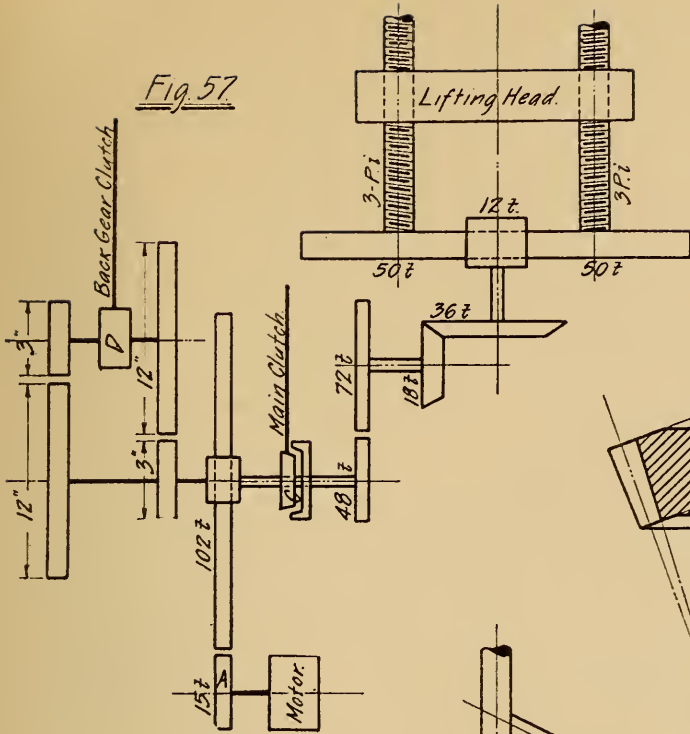

Fig. 58

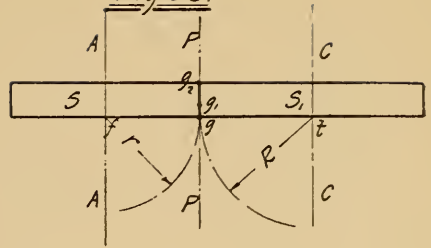

Fig. 59

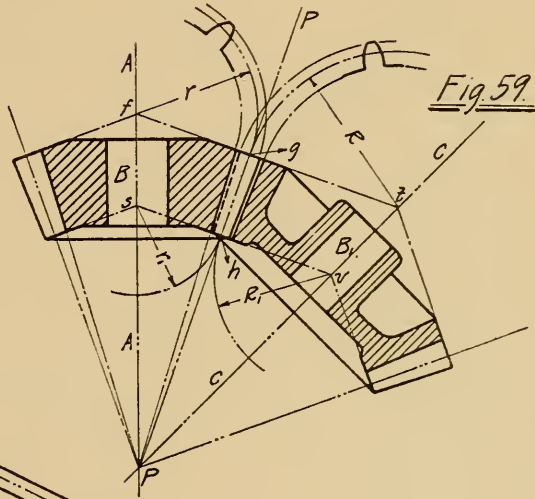

Fig. 60

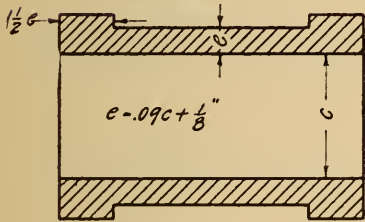

Fig. 62

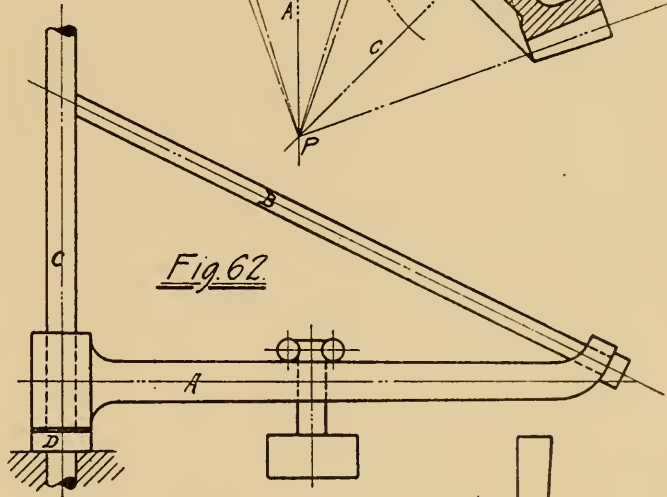

Fig. 61

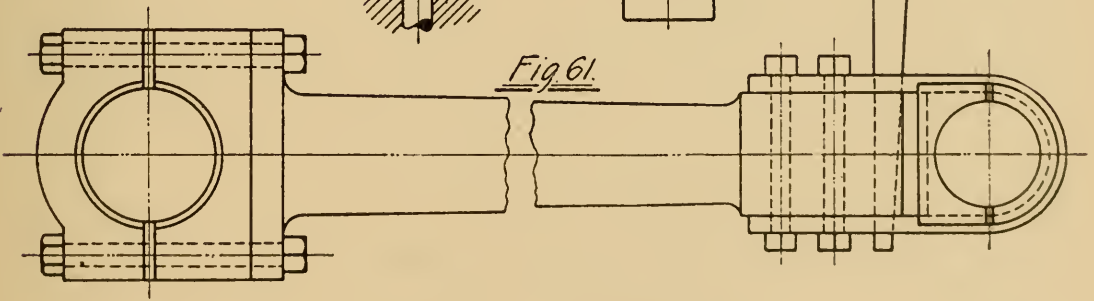

Fig. 63

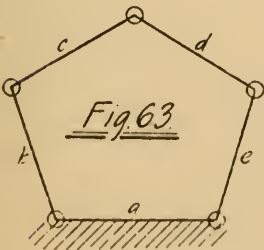
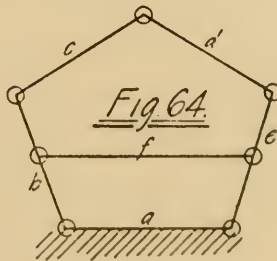

Fig. 64



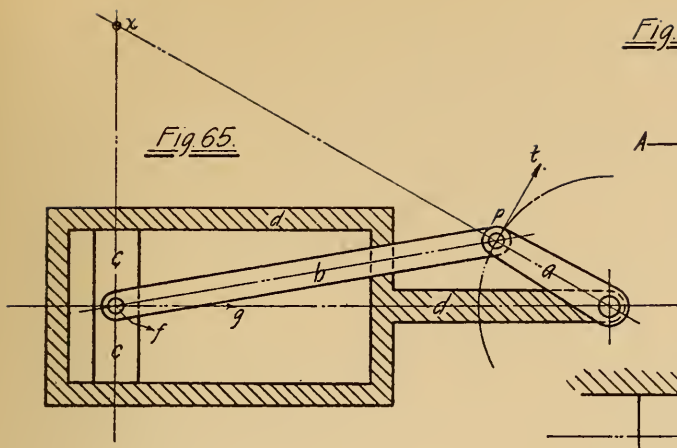

Fig. 65.

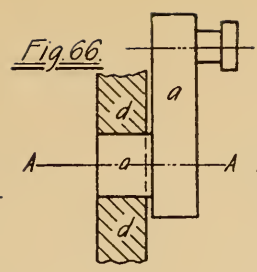

Fig. 66.

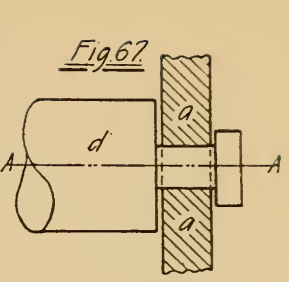

Fig. 67.

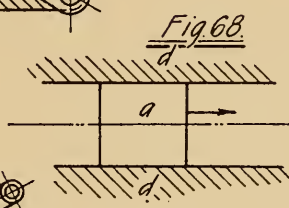

Fig. 68.

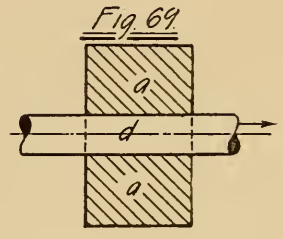

Fig. 69.

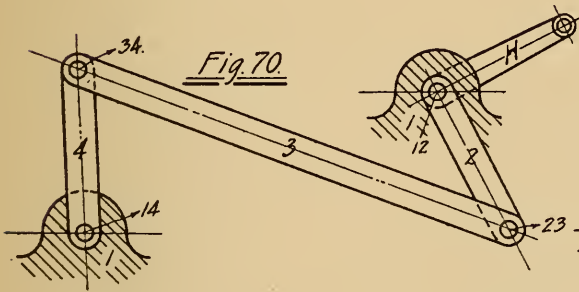

Fig. 70.

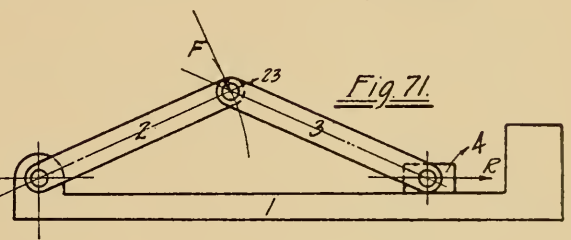

Fig. 71.

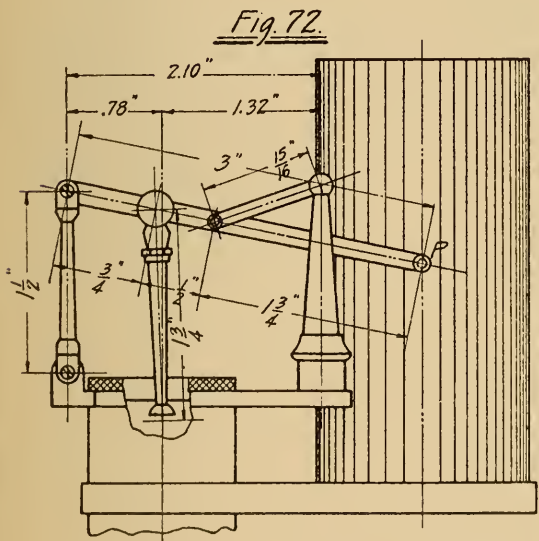

Fig. 72.

Diagram of Thompson Indicator.

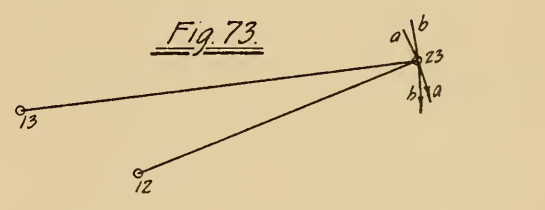

Fig. 73.

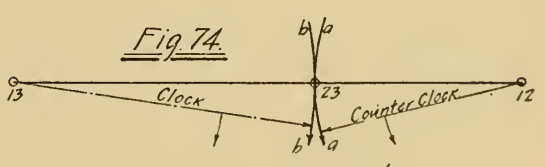

Fig. 74.

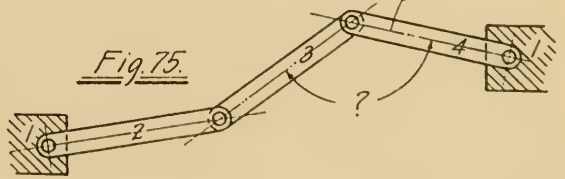

Fig. 75.

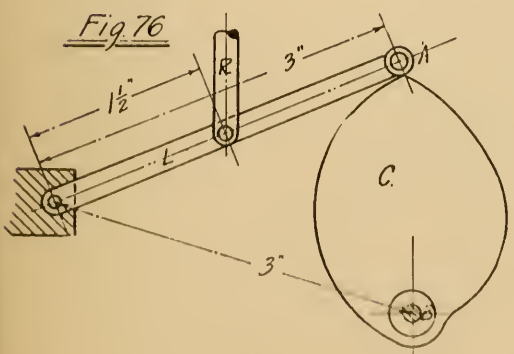

Fig. 76.

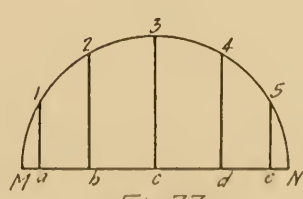

Fig. 77.

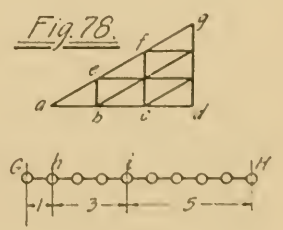

Fig. 78.

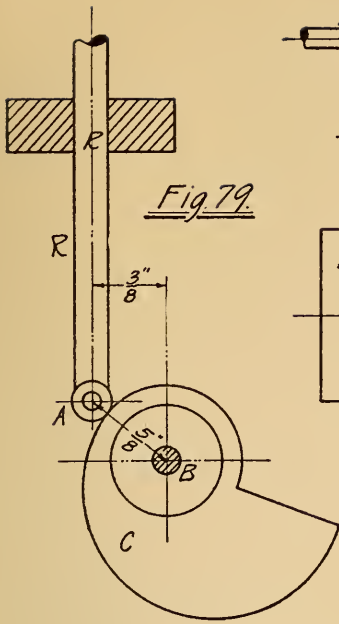

Fig. 79

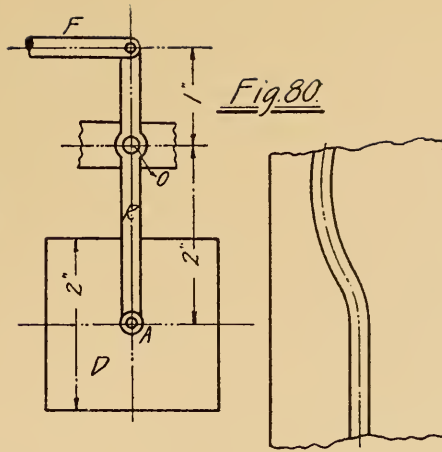

Fig. 80

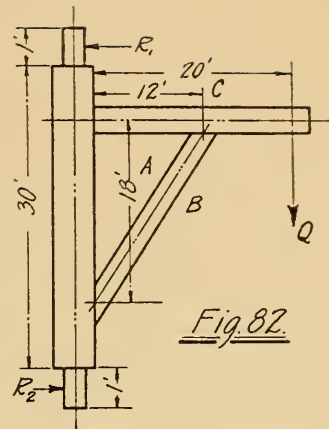

Fig. 82

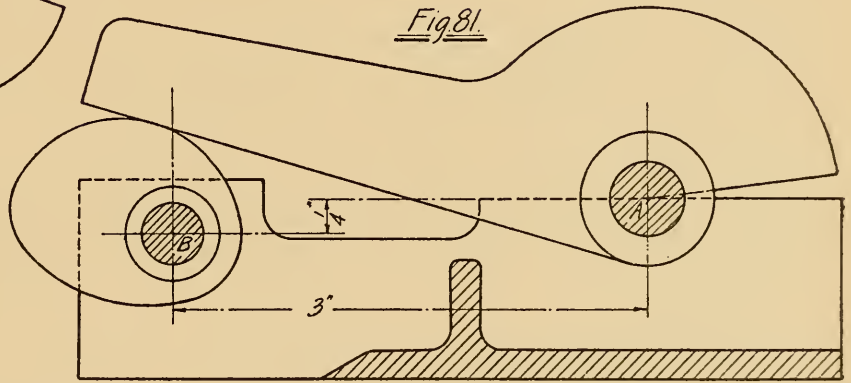

Fig. 81

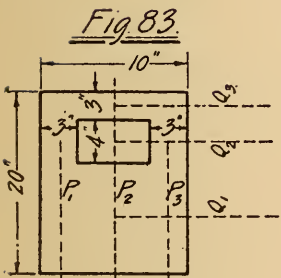
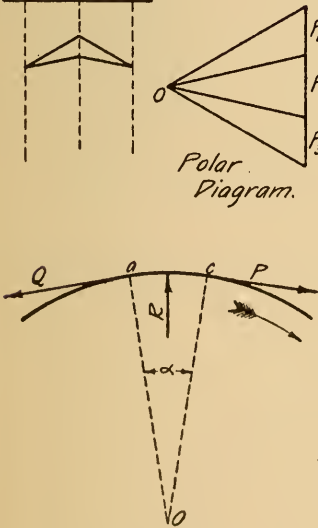
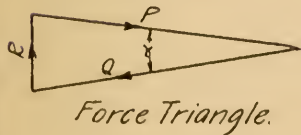

Fig. 83



Polar Diagram.

Fig. 86



Force Triangle.

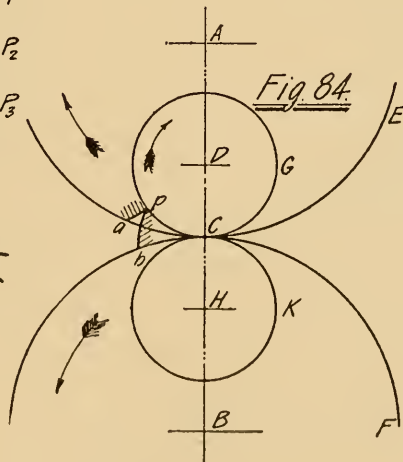

Fig. 84

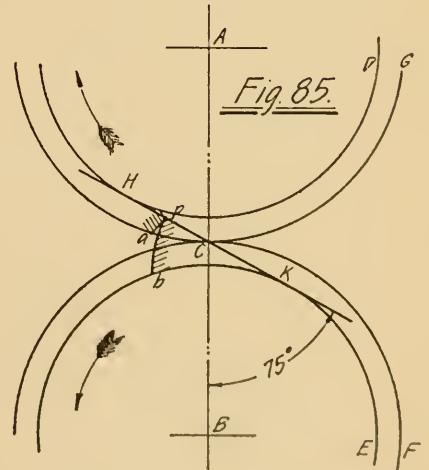
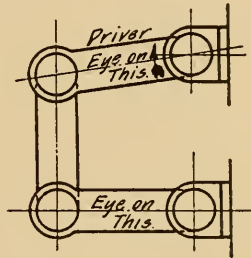
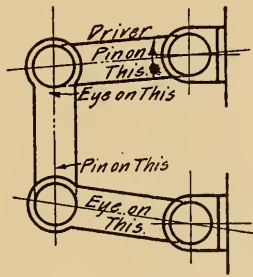
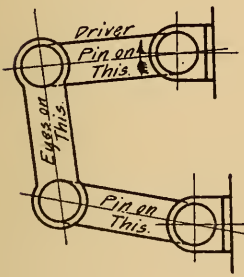
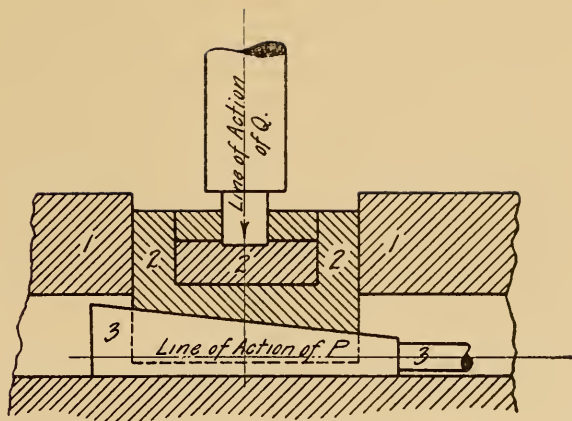
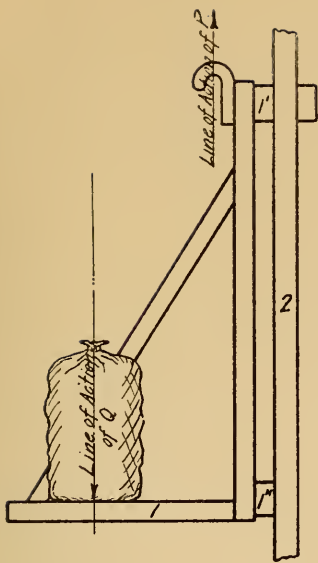

Fig. 85

To prove cycloidal curve is suitable for tooth profile.

To prove involute curve is suitable for tooth profile.



Coefficient Journal Friction = $\frac{1}{10}$

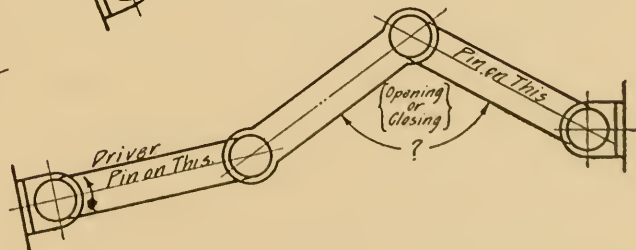
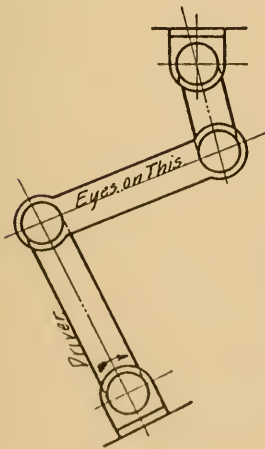
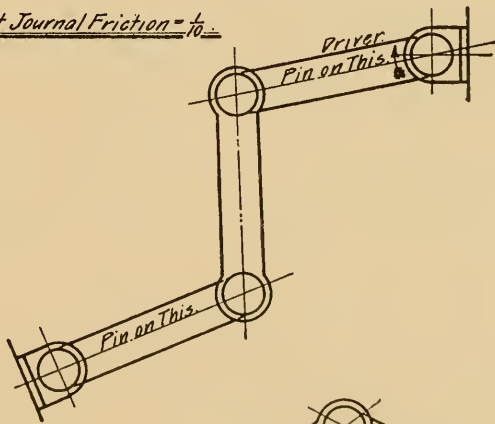
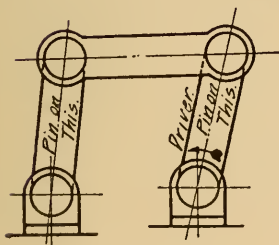

Section A-B

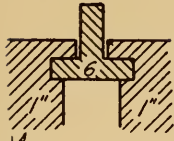

Shaper
 Coeff. of { Sliding Friction = $\frac{1}{8}$
 Journal Friction = $\frac{1}{16}$

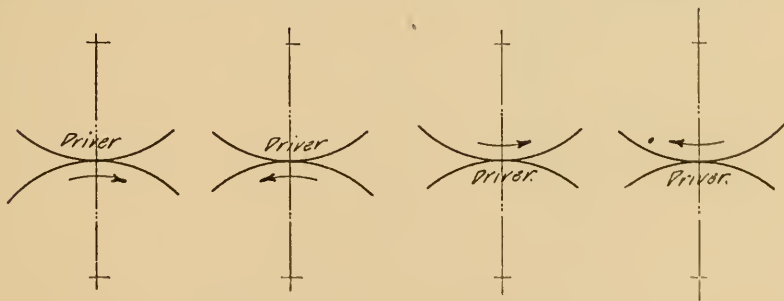
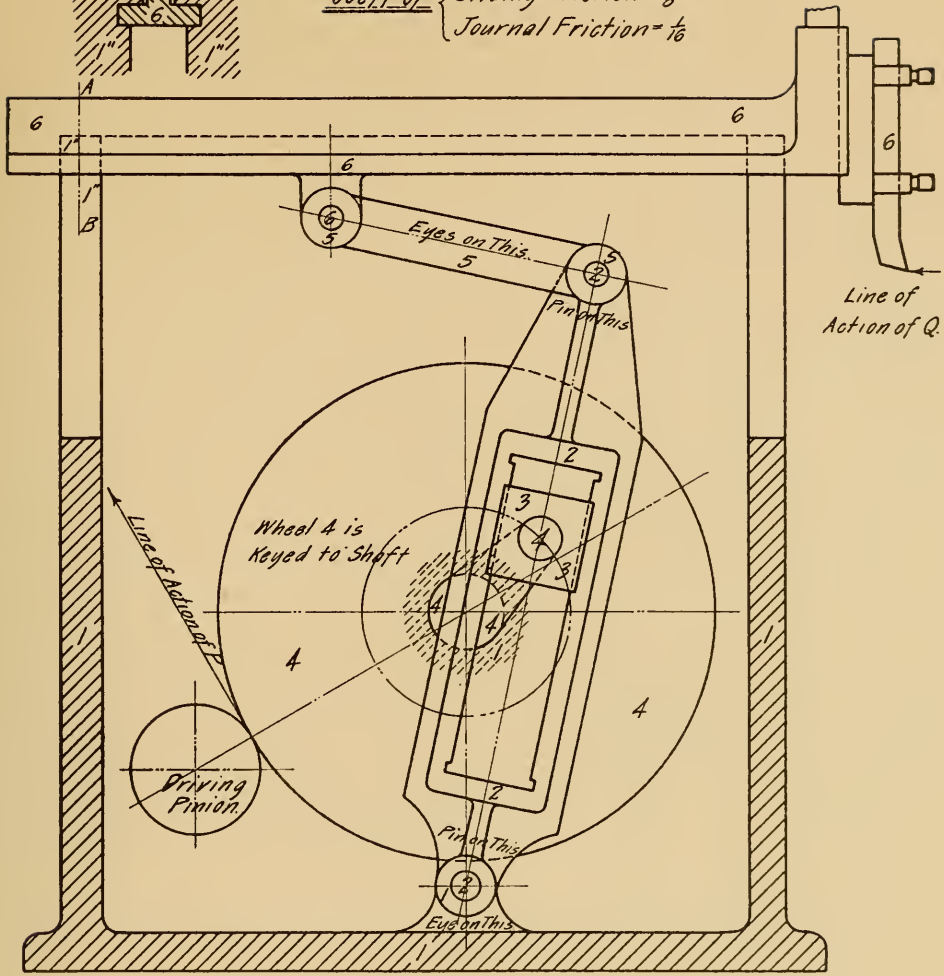

In the above locate line of tooth thrust without friction. Also
 with friction Assume $\frac{44 \pi}{2} = \frac{1}{8}$

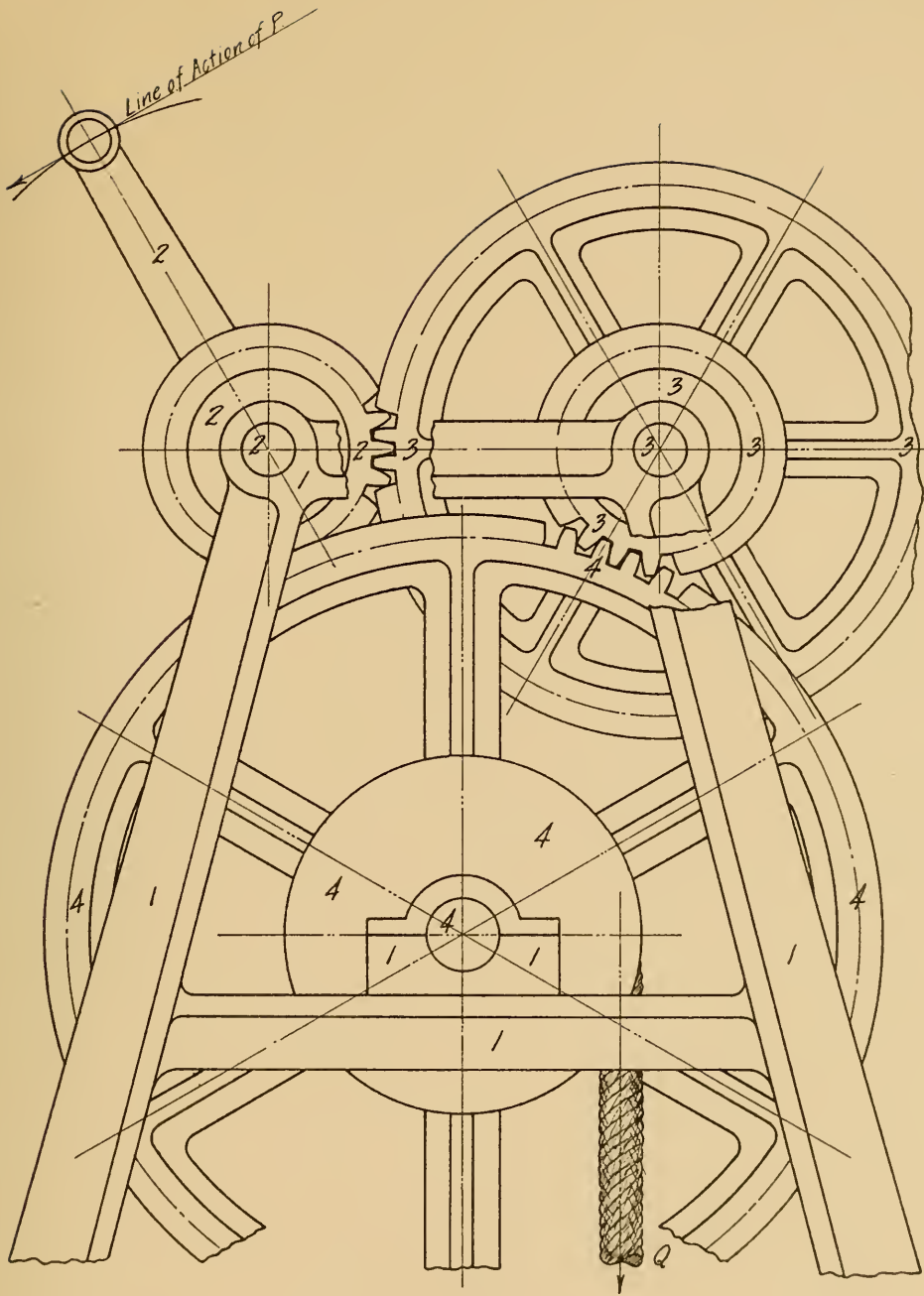

Coeff. of $\left\{ \begin{array}{l} \text{Journal friction} = \frac{1}{12}. \\ \text{Tooth friction} = 0.2. \\ \text{Rope stiffness} = 0.23 d^2 \text{ (inches)} \end{array} \right.$

Grapical Statics
Plate III

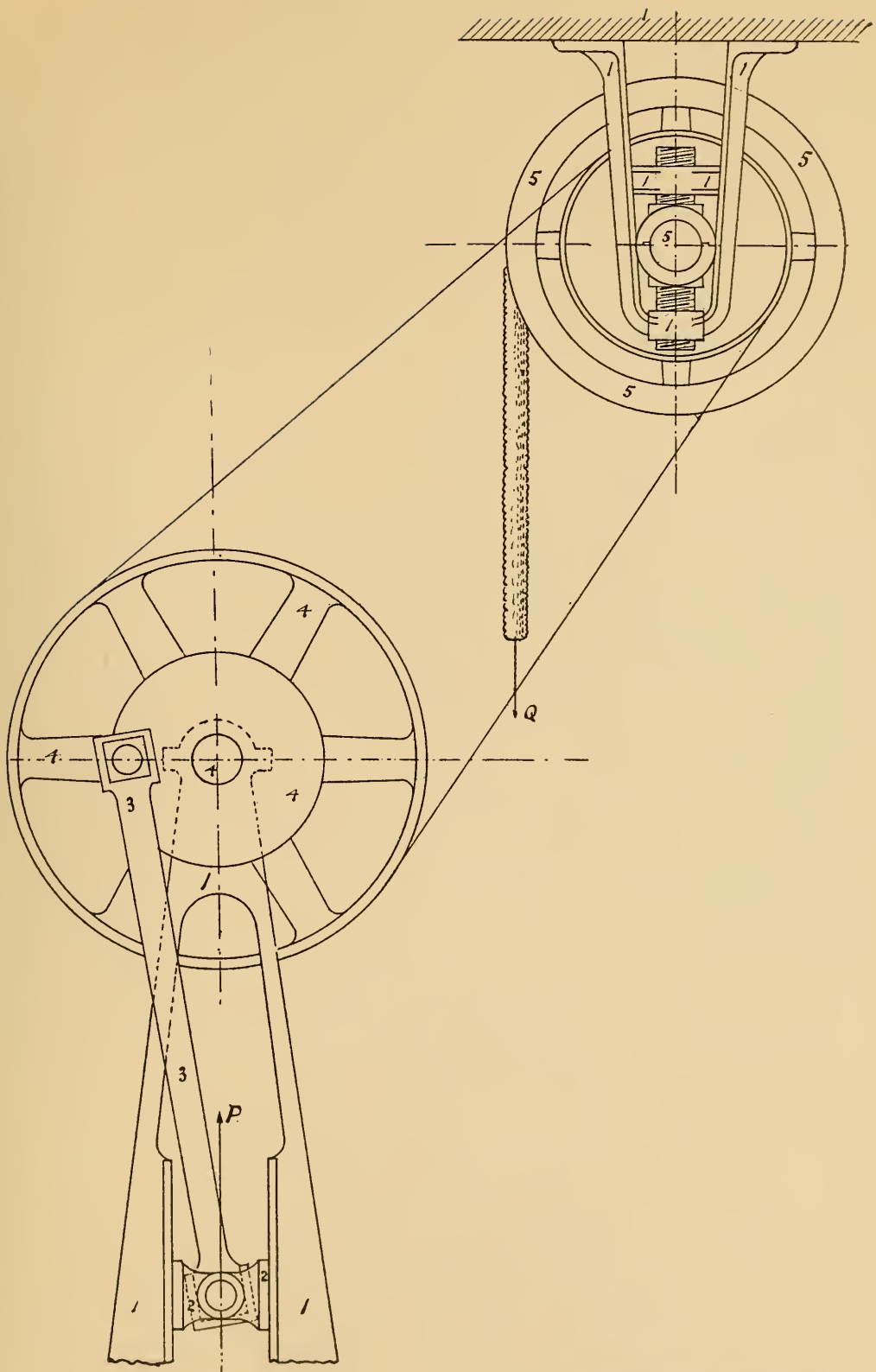

Grapical Statics
 Plate IV

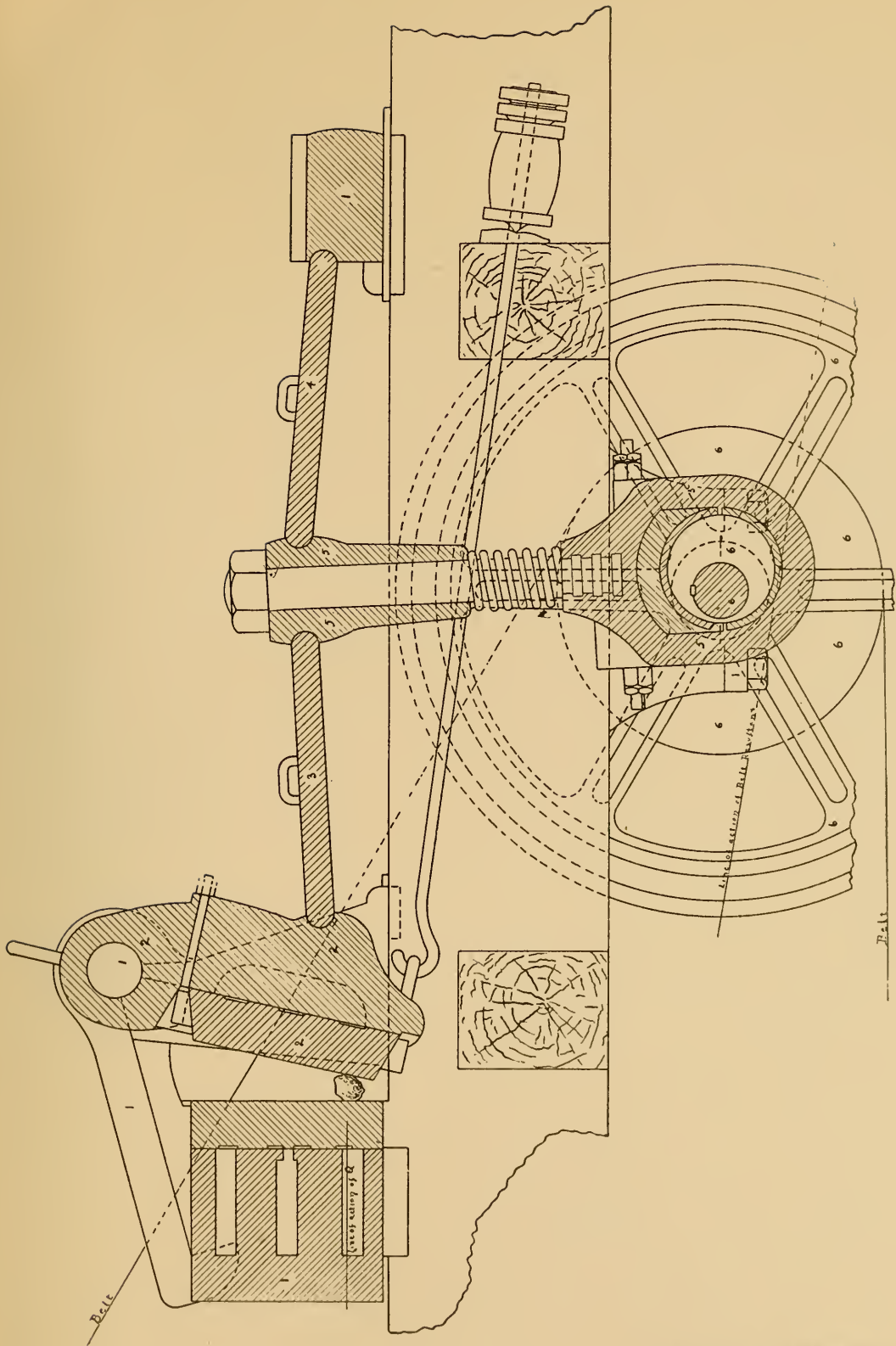

Grapical Statics
Plate V

JAN 11 1910

One copy del. to Cat. Div.

JAN 11 1910

LIBRARY OF CONGRESS



0 019 973 572 A