



00110664

THE
ASIATIC SOCIETY OF BOMBAY
Town Hall, Bombay.

THE ANNOTATED
BOOK OF COMMON PRAYER

BEING AN

HISTORICAL, RITUAL, AND THEOLOGICAL COMMENTARY

ON THE DEVOTIONAL SYSTEM

OF

The Church of England

110664

EDITED BY THE

REV. JOHN HENRY BLUNT, M.A., F.S.A.

AUTHOR OF "THE HISTORY OF THE REFORMATION," "DIRECTORIUM PASTORALE," ETC. ETC.

"Thus saith the Lord, Stand ye in the ways, and see, and ask for the old paths, where is the good way, and walk therein, and ye shall find rest for your souls."—JEREMIAH vi. 16.

RIVINGTONS

London, Oxford, and Cambridge

1869

[Fourth Edition]

110664



00110664

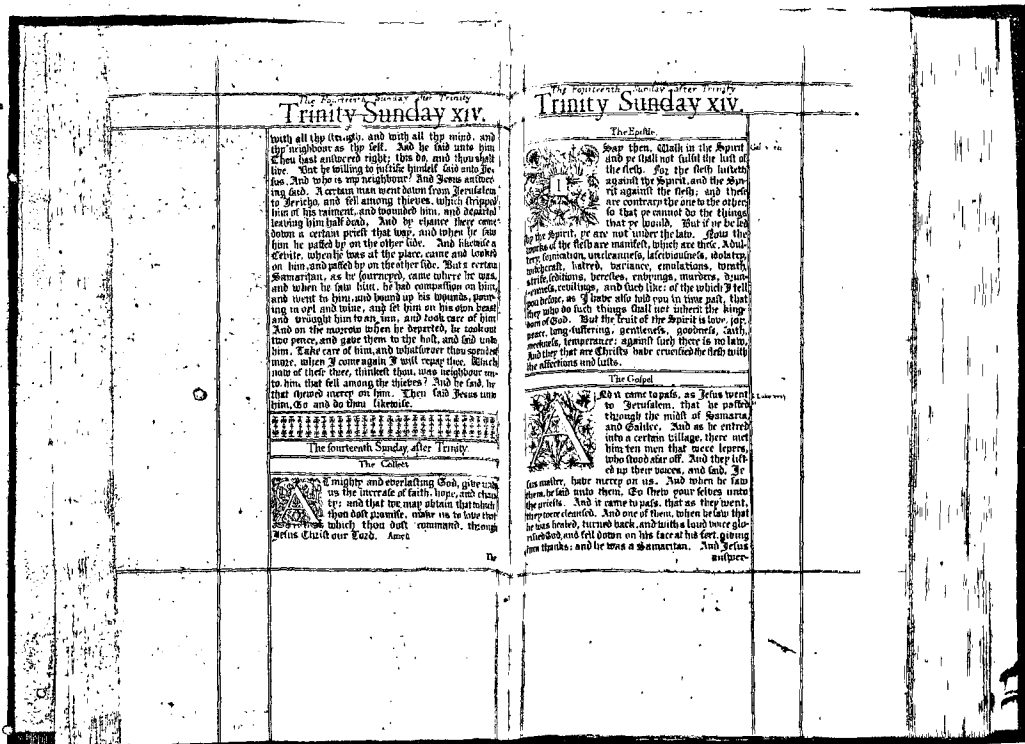

The Fourteenth Sunday after Trinity
Trinity Sunday xiv.

with all the strength, and with all the mind, and
the neighbour as thy self. And he said unto him
These last thou hast done right: but the first thou
hast not. That he willing to justify himself, said unto Je-
sus, And who is my neighbour? And Jesus answer-
ed, saying, A certain man went down from Jerusalem
to Jericho, and fell among thieves, which stripped
him of his raiment, and wounded him, and departed
leaving him half-dead. And by chance there came
down a certain priest that way, and when he saw
him, he passed by on the other side. And likewise
a Levite, when he saw him, he also passed by on
the other side. But a certain Samaritan, as he
journeyed, came where he was, and when he saw
him, he had compassion on him, and went to him,
and bound up his wounds, pouring in oil, and
wine, and set him on his own beast, and brought
him to an inn, and took care of him. And on the
morrow when he departed, he gave him two
pence, and gave them to the host, and said unto
him, Take care of him, and whatsoever thou shalt
more, when I come again, I will repay thee. Which
now of these three, thinkest thou, was neighbour
unto him that fell among the thieves? And he
said, he that showed mercy on him. Then said
Jesus unto him, Go and do thou likewise.

The Collect

The Collect

The Collect

The Fourteenth Sunday after Trinity
Trinity Sunday xiv.

The Epistle

I keep them, shall in the Spirit
and so shall not fulfil the law of
the flesh. For the flesh lusteth
against the Spirit, and the Spirit
against the flesh, and these
are contrary the one to the other,
so that ye cannot do the things
that ye would. But if ye be led
by the Spirit, ye are not under the law. Now the
works of the flesh are manifest, which are these, Adul-
tery, fornication, uncleanness, inordinance, idolatry,
hatred, variance, emulations, wrath,
strife, jealousies, murders, drunken-
ness, revellings, and such like: of the which I tell
you, as I have also told you in time past, that
they who do such things shall not inherit the king-
dom of God. But the fruit of the Spirit is love, joy,
peace, long-suffering, gentleness, goodness, faith,
meekness, temperance: against such there is no law.
And they that are Christ's have crucified the flesh with
the affections and lusts.

The Gospel

As he came to pass, as Jesus went
to Jerusalem, that he passed
through the midst of Samaria
and Galilee. And as he entered
into a certain village, there met
him ten men that were lepers,
who stood afar off. And they lift-
ed up their voices, and said, Je-
sus, have mercy on us. And when he saw
them, he said unto them, Go, show your-
selves unto the priests. And as they went,
they were cleansed. And one of them, when he saw
that he was healed, turned back, and with a loud
voice glorified God, and fell down on his face at his
feet, giving him thanks: and he was a Samaritan. And Jesus
answered, saying,

THE SEALED COPY
of the Book of Common Prayer.

P R E F A C E.

THIS work is an attempt to gather into one concise view all the most important information that is extant respecting the devotional system of the Church of England as founded on the Book of Common Prayer.

Much research and study have been expended upon this subject during the last quarter of a century ; and the Prayer Book has been largely illustrated by the works of Sir William Palmer, Mr. Maskell, and Archdeacon Freeman. Many smaller books than these have also been published with the object of bringing into a compact form the results of wide and learned investigations : the most trustworthy and complete of all such books being Mr. Procter's excellent " History of the Book of Common Prayer, with a Rationale of its Offices." But it has long seemed to the Editor of the present volume that a work of another kind was wanted, which (without superseding any previous one of established merit) should exhibit more concisely and perspicuously the connexion between the ancient and the modern devotional system of the Church of England by placing the two side by side, as far as the former is represented in the latter : and which should also give a general condensed illustration of our present Prayer Book from all those several points of view from which it must be regarded if it is to be properly understood and appreciated.

Perhaps there is no one book, except the Holy Bible, which has been so much written about as the Prayer Book since the Reformation, and perhaps so much was never written about any one book which left so much still unsaid. The earliest class of commentators is represented by John Boys, who died Dean of Canterbury in 1619, and who had in earlier life published a Volume of Postils which were preceded by a diffuse comment on the principal parts of the Prayer Book. In these there is much ponderous learning, but a total absence of any liturgical knowledge. Bishop Andrewes and Archbishop Laud began to open out the real meaning and the true bearing of our Offices, being well acquainted with the Greek Liturgies, and having some knowledge, at least, of the Breviaries and the Missals of the Church of England. L'Estrange, Sparrow, Cosin,

PREFACE.

and Elborow represent a still further advance towards a true comprehension of the Prayer Book; Bishop Cosin especially being thoroughly familiar with the Sarum Missal, and perhaps with the Breviary and other Office-books of the old Church of England. In the latter part of the sixteenth century, Liturgical studies seem, indeed, to have been taken up by many of the Clergy, especially by the Nonjurors, and interleaved Prayer Books are preserved in the Bodleian and other libraries which testify to the industry that was shown in illustrating its text, especially from the Greek Liturgies. None seem so thoroughly to have qualified themselves for the task of illustrating and interpreting the Book of Common Prayer as Fothergill, a nonjuror, whose interleaved Prayer Book in eleven large volumes, together with his unmatched collection of old English Service-books, is now in the Chapter Library at York¹. But his notes and quotations were not digested into order: and although a work founded upon them would have been invaluable in days when there was no better authority than the superficial Wheatley, they have since been superseded by the publications of Palmer and Maskell.

The works of Comber, Wheatley, and Shepherd, were doubtless of great value in their way; but it is melancholy to observe that they tended in reality to alienate the minds of their readers from all thought of Unity and Fellowship with the Church of our Fathers, and set up two idols of the imagination, a Church originated in the sixteenth century, and a Liturgy "compiled," and in the main invented, by the Reformers. There is not a single published work on the Prayer Book previous to the publication of Palmer's *Origines Liturgicæ* in 1832, which makes the least attempt to give a truthful view of it, so thoroughly was this shallow conceit of a newly-invented Liturgy ingrained in the minds of even our best writers.

Notwithstanding, therefore, the great abundance of works on the Book of Common Prayer, there seems to be still ample room for one like the present, in which the spirit of our Offices is illustrated from their origin and history as well as from their existing form; and in which a large body of material is placed before the reader by means whereof he may himself trace out that history, and interpret that spirit.

The object of the present work may be stated, then, to be that of illustrating and

¹ Marmaduke Fothergill was born at York in 1652, took his degree at Magdalene College, Cambridge, and became Rector of Skipwith. In 1688 he was offered the Rectory of Lancaster, but not being able to take the oaths to William and Mary, he could neither accept preferment, nor receive the degree of D.D., for which he had qualified. He lived at Pontefract, till driven thence by a whig J. P., but died in Westminster, on Sept. 7, 1731. Mr. Fothergill made a

noble collection of ancient Service-books, which, with the rest of his Library, he left to Skipwith parish, on condition of a room being built to receive them. This not being done, the widow applied to Chancery, and by a decree of that court the books were all handed over to York Minster. Mr. Fothergill also left an endowment of £50 a year for a catechist at Pontefract. His volumes show that he was a most industrious reader.

PREFACE.

explaining the Devotional system of the Church of England by (1) a careful comparison of the Prayer Book with the original sources from which it is derived, (2) an examination of all the details of its history, and (3) a full consideration of the aspects which it appears when viewed by the light of those Scriptural and primitive principles on which the Theology of the Church of England is founded.

For the plan of the work, the general substance of it, and for all those portions of its authorship of which is not otherwise indicated, the Editor must be held responsible. For the details of the text and notes in those parts which have been contributed by others (excepting the Marginal References), the authors must, of course, be considered individually responsible. Circumstances have arisen which threw into the Editor's hands a larger proportion of the work than he originally intended to undertake, especially in connexion with the Communion and the Occasional Offices; but he does not wish to claim any indulgence on this account, being fully assured that a commentary of the kind here offered ought to be judged solely by its merits as an authentic interpretative guide. The Introduction to the Communion Service, and the earlier portion of the Notes upon it are by the Editor.

In the Offices for the Visitation and Communion of the Sick, the Editor has to acknowledge valuable assistance from a friend who does not permit his name to be used. Those Offices have been treated in a rather more homiletic method than most of the others, in the hope that the Notes may assist in persuading both Lay and Clerical readers to desire a more pointed and systematic application of the Church's gifts in times of Sickness than that which is offered by the prayers ordinarily used.

The text is, of course, that of the Sealed Books; but some liberty has occasionally been taken with the punctuation, which, whether in the Sealed Books, or in the copies sent out by the Universities and the Queen's Printers, is in a most unsatisfactory condition. In the Psalms and Canticles, a diamond-shaped "point" has been used for the purpose of more plainly marking the musical division of verses, as distinguished from the grammatical punctuation. The spelling is also modernized throughout.

In conclusion, the Editor begs to tender his grateful thanks to many friends who have assisted him with their suggestions and advice. Those thanks are also especially due to the Rev. T. W. Perry, of Brighton, and the Rev. W. D. Macray, of the Bodleian Library, who have gone through all the proof-sheets, and have been largely instrumental in securing to the reader accuracy in respect to historical statements.

The Editor is indebted to the REV. JOHN BACCHUS DYKES, M.A., and Doctor of Music, Vicar of St. Oswald's, Durham, for the Second Section of the Ritual Introduction, on THE MANNER OF PERFORMING DIVINE SERVICE.

The Third Section of the Ritual Introduction, on THE ACCESSORIES OF DIVINE

PREFACE.

is by the REV. THOMAS WALTER PERRY, author of "Lawful Church Ornaments,"

THE REV. JOSEPH THOMAS FOWLER, M.A., Chaplain of St. John's College, Hurst-
t, is the writer of the Notes on the MINOR HOLYDAYS of the Calendar.

THE REV. WILLIAM BRIGHT, M.A., Fellow and Tutor of University College, Oxford,
author of "A History of the Church from A.D. 313 to A.D. 451," "Ancient
ts," &c., &c., is the writer of the INTRODUCTION TO, AND NOTES ON THE LITANY.
of the ESSAY ON THE SCOTTISH LITURGY in the Appendix.

THE REV. PETER GOLDSMITH MEDD, M.A., Dean and Tutor of University College,
rd, co-Editor with Mr. Bright of the Latin Prayer Book, and author of "House-
Prayer," &c., is the principal writer of the NOTES ON THE COMMUNION OFFICE from
Church Militant Prayer to the end; and the compiler of the APPENDIX to that
e. Mr. Medd has also contributed the references to the hymns of the seasons.

THE REV. MACKENZIE E. C. WALCOTT, B.D., F.R.S.L., F.S.A., of Exeter College,
rd, Precentor and Prebendary of Chichester Cathedral, and author of "THE
GLISH ORDINAL," &c., &c., has contributed the INTRODUCTION TO, AND NOTES ON THE
DINAL.

The Editor also desires to acknowledge his obligations to the valuable libraries of
e Cathedrals of Durham and York, to Bishop Cosin's Library, and the Routh Library,
Durham; and to the Hon. and Rev. Stephen Willoughby Lawley, M.A., Rector of
scrick, to whom the reader is indebted for some rare mediæval illustrations of the
asional Offices, and whose courtesy has otherwise facilitated that portion of the
k.

TABLE OF CONTENTS.

	PAGE
PREFACE	v
List of Authorities	xi
Chronological Table	xv
An Historical Introduction to the Prayer Book	xvii
A Ritual Introduction to the Prayer Book —	
Section I. The Principles of Ceremonial Worship	xlvi
Section II. The Manner of performing Divine Service. By Rev. J. B. Dykes, Mus. D.	li
Section III. The Accessories of Divine Service. By Rev. T. W. Perry	lxxv
Title, &c., of the Sealed Prayer Books	[1
Acts of Uniformity	[4
Preface, &c., to the Prayer Book	[11
Tables and Rules	[24
An Introduction to the Calendar	[36
The Calendar with Comparative View	[38
Notes on the Minor Holydays. By Rev. J. T. Fowler	[39
An Introduction to Morning and Evening Prayer	[62
Morning Prayer	1
Evening Prayer	29
Athanasian Creed	41
An Introduction to the Litany. By Rev. W. Bright	46
The Litany, with Notes. By Rev. W. Bright	49
Occasional Prayers and Thanksgivings	61
An Introduction to the Collects, Epistles, and Gospels	68
The Collects, Epistles, and Gospels	72
An Introduction to the Liturgy	145
The Order for the Holy Communion, with Notes. By Rev. P. G. Medd, and the Editor	163
An Appendix to the Communion Office. By Rev. P. G. Medd	200
An Introduction to the Offices for Holy Baptism	208
The Ministration of Public Baptism to Infants, with Notes	215
The Ministration of Private Baptism of Children in houses, with Notes	231
The Ministration of Baptism to such as are of Riper Years, with Notes	236
An Introduction to the Catechism	241
The Catechism, with Notes	244
An Introduction to the Confirmation Office	251
The Order of Confirmation, with Notes	254
The Form of Solemnization of Matrimony, with Notes	261
An Introduction to the Office for the Visitation of the Sick	275
The Order for the Visitation of the Sick, with Notes	277
The Communion of the Sick, with Notes	289
The Order for Burial of the Dead, with Notes	293
An Appendix to the Burial Office	301

CONTENTS.

	PAGE
The Churching of Women, with Notes	304
The Communion, with Notes	307
An Introduction to the Psalter	313
The Psalms, with Notes	318
Forms of Prayer to be used at Sea, with Notes	525
An Introduction to the Ordinal. By Rev. Mackenzie E. C. Walcott	530
The Form and Manner of Making Deacons, with Notes. Ditto	545
The Form and Manner of Ordering of Priests, with Notes. Ditto	554
The Form of Ordaining or Consecrating of an Archbishop or Bishop, with Notes. Ditto	566
GENERAL APPENDIX—	
I. The State Services. By Rev. W. D. Macray	578
II. The Scottish Prayer Book of 1637. By Rev. W. Bright	580
III. The Irish Prayer Book. By Rev. W. D. Macray	585
IV. Additional Note on the Latin Prayer Book	586
V. Additional Note on the Litany	<i>ib.</i>
VI. Ecclesiastical Vestments. By Rev. T. W. Perry	587
• Index and Glossary	589

ILLUSTRATIONS.

The Sealed Book belonging to the Dean and Chapter of Durham	<i>Frontispiece</i>
A Horn Book *	page xxiv
Ecclesiastical Vestments (two Plates). By G. E. Street, Esq.	To face page 588

A LIST OF THE PRINCIPAL

LITURGICAL AND HISTORICAL AUTHORITIES

QUOTED OR REFERRED TO IN THIS WORK.

- Amalarius Symphosius [circ. A.D. 820—A.D. 827], *De Divin. Off.* Cologne, 1568.
Andrewes, Bishop, *Notes on Prayer Book.* Ang. Cath. Lib. 1854.
Anglican Church Calendar. 1851.
Assemani Codex Liturgicus.
Baker, Sir Richard, on the Lord's Prayer. 1638.
Beleth [thirteenth century], *Rationale Divin. Off.* Lyons, 1612.
Bingham's Antiquities of the Christian Church.
Blunt's Directorium Pastorale.
Bona, Cardinal, *De Rebus Liturg.* Paris, 1676.
————— *De Divinâ Psalmodiâ.* Antwerp, 1677.
Brady's Clavis Calendaria. 1812.
Breviary, Mozarabic.
————— *Roman.*
————— *Salisbury.* 1495—1541.
————— *York.* 1493—1526.
Bright's Ancient Collects and other Prayers.
Brogden's Illustrations of the Liturgy. 1842.
Bulley's Variations of the Communion and Baptismal Offices.
Burn's Ecclesiastical Law. Phillimore's ed., 1842.
Burney's History of Music.
Burnet, Bishop, History of the Reformation.
————— *Vindication of English Ordinations.*
Butler's Lives of the Saints.
Calendars of State Papers. Domestic. 1547—1580.
————— 1660—1662.
Cardwell, Documentary Annals.
————— *History of Conferences.*
————— *Synodalia.*
————— *Three Primers of 1535, 1539, 1545.*
————— *Two Liturgies of Edward VI.*
Catalani, Pontif. Roman. Commentariis illustratum. 1738.
Churton's Life of Dean Nowell.
Collier's Ecclesiastical History.
Comber on the Common Prayer.

- Cosin, Book of Common Prayer, 1619 ed., with MS. emendations. D. III. 5, Cosin's Durham.
- Collection of Private Devotions. 1627.
- Notes and Collections on the Prayer Book. Works, Vol. V. Ang. Cath. Lib. 1855.
- ✓ Daniel, Codex Liturgicus.
- Thesaurus Hymnologicus.
- Documents relating to the Act of Uniformity. 1862.
- Durandus [A.D. 1216], Rationale Divin. Off. Lyons, 1612.
- Dyce, Book of Common Prayer with Plain Tune.
- Elborow on the Book of Common Prayer. 1663.
- English Church Union Kalendars. 1863-4.
- Farrow's Baptismal Offices illustrated. 1838.
- Fleury's Church History. Newman's transl.
- Forbes', Bishop, Explanation of the Nicene Creed.
- Commentary on the Litany.
- Freeman's Principles of Divine Service.
- Rites and Ritual.
- Gavanti Thesaurus Sacrorum Rituum. 1792.
- Gelasius' Sacramentary [A.D. 492]. Muratori's ed.
- Gerberti Liturgia Alemannica.
- Goar, Rituale Græcorum. 1647.
- Grancolas, Commentarius Historicus in Romanum Breviarium. Venice, 1734.
- Grand Debate between the Bishops and the Presbyterians. 1661.
- Gregory, St., Sacramentary [A.D. 590]. Menard's ed.
- Greswell on the Burial Service. 1836.
- Gueranger's Institutions Liturgiques. 1840—1851.
- Guericke's Manual of Church Antiquities. Morrison's translation. 1851.
- Hal's Precedents. 1847.
- Hallier, De Sacris Ordinationibus. 1636.
- Harvey on the Creeds. 1854.
- Hermann's Simplex ac Pia Deliberatio. 1545.
- Daye's translation [edd. 1547, 1548].
- Heurtley's Collection of Creeds. 1858.
- Heylin's History of the Reformation. Ecc. Hist. Soc.
- Hiekes' Letters [Lib. Ecc. Cath. Dunelm. *ex dono Auctoris*]. 1705.
- Hierurgia Anglicana. 1848.
- Hittorpius, De Divinis Officiis. Cologne, 1568.
- Jebb's Choral Service.
- Ritual Law and Custom of the Church Universal.
- Jenkyns' Cranmer's Remains.
- Jerome, St., Comes or Lectionary. Pamelius' ed. Cologne, 1571.
- Kalendar of the English Church. 1865-6.
- Keble's Eucharistical Adoration. 1857.
- Kennett's, Bishop, Register. 1728.
- Landon's Ecclesiastical Dictionary. 1849.
- Manual of Councils. 1846.
- Lathbury's History of the Convocation. 1853.
- Prayer Book. 1859.
- Leo, St., Sacramentary [A.D. 451]. Muratori's ed.
- L'Estrange's Alliance of Divine Offices [A.D. 1690]. Ang. Cath. Lib. 1846.
- Lingard's Antiquities of the Anglo-Saxon Church.
- Littledale, North-side of the Altar.
- On the Mixed Chalice.
- Liturgies, &c., of K. Edward VI. Parker Soc. 1844.

- Liturgies, &c., of Q. Elizabeth. Parker Soc. 1847.
- Mabilloz \ Museum Italicum. 1687-9.
- De Liturgiâ Gallicanâ. Paris, 1685.
- Manuale Sarisburiensis. 1498.
- Martene, De Antiquis Ecclesiæ Ritibus. Antwerp, 1763.
- Maskell, Ancient Liturgy of the Church of England. 1846.
- Dissertation on Holy Baptism. 1846.
- Monumenta Ritualia Ecc. Ang. 1848.
- On the Doctrine of Absolution. 1849.
- Mason, Vindiciæ Ecc. Anglic. sive de legitimo ejusdem Ministerio.
- Massingberd, Lectures on the Prayer Book.
- Masters' reprint of the Sealed Book of Common Prayer. 1848.
- Meibomius, Antiquæ Musicæ Auctores Septem. 1652.
- Merbecke's Common Prayer Noted. 1550.
- Micrologus [Johannis, Episcopi, thirteenth century. Maskell's date, 1080]. Pamelius' ed. Antwerp, 1565.
- Mirrore of our Ladye. 1530.
- Missale ad Usus ac Consuetudinem Sarum. Paris, 1514.
- , pars prima, temporale. Burntisland. 1861.
- Morinus, De Sacris Ordinationibus. 1655.
- Muratori, Liturgia Romana Vetus. 1748.
- Neale's Commentary on the Psalms, Vol. I. 1860.
- Essays on Liturgiology. 1863.
- Introduction to the History of the Holy Eastern Church. 1850.
- Primitive Liturgies.
- Tetralogia Liturgica. 1849.
- Palmer's Origines Liturgicæ. 1832.
- Pamelius [A.D. 1536—1587], Antiquitates Liturgicæ.
- Liturgicon Ecclesiæ Latinæ. Cologne, 1571.
- Parker, Correspondence of Archbishop. Parker Soc. 1853.
- Perry's Historical Considerations relating to the Declaration on Kneeling. 1863.
- Pickering's reprints of the Books of Common Prayer.
- Pinnock's Laws and Usages of the Church and Clergy.
- Pontificals of Salisbury, Bangor, and Exeter.
- Portiforii seu Breviarii Sarisb. fascic. i. and ii. 1843-5.
- Position of the Priest at the Altar. 1858.
- Poullain's L'Ordre des Prières, &c. London, 1552.
- Prideaux's Validity of English Orders.
- Private Prayers of the Reign of Edward VI. Parker Soc.
- Queen Elizabeth. Parker Soc.
- Procter's History and Rationale of the Prayer Book. 1857.
- Psalter, Anglo-Saxon and Early English. Surtees' Soc. 1843-7.
- Translation of Sarum, with Explanatory Notes and Comments. 1852.
- Purchas' Directorium Anglicanum. 1858.
- 2nd ed., edited by Rev. F. G. Lee. 1865.
- Pusey's Doctrine of the Real Presence.
- The Real Presence the Doctrine of the English Church.
- Scriptural Views of Holy Baptism.
- Quignonez, Cardinal, Reformed Roman Breviary. Lyons, 1543. [Edd. 1535-6 to 1568.]
- Renaudot, Liturg. Orient. Collectio.
- Scudamore, The Communion of the Laity. 1855.
- Sparrow, Bishop, Collection of Articles, Injunctions, &c. 1661.
- Rationale of the Prayer Book.
- Stephens' edition of Sealed Book of Common Prayer. Ecc. Hist. Soc. 1849-54.

- Stephens' Book of Common Prayer, from the Irish MS. in the Rolls' Office, Dublin. Ecc. Hist. Soc.
Strype's Memorials of Cranmer. Ecc. Hist. Soc.
Thomassii Opera. 1747-69.
Thomassin, Discipline de l'Eglise, &c. 1679-81.
Thomson, Vindication of the Hymn Te Deum Laudamus. 1858.
Thrupp on the Psalms.
Tyler, Meditations from the Fathers illustrating the Prayer Book. 1849.
Walafridus Strabo [A.D. 830], De Rebus Ecc. Cologne, 1568.
Warren's Answer to Maskell on Absolution. 1849.
——— The Lord's Table the Christian Altar. 1843.
Wheatley on the Common Prayer. Corrie's ed., 1858.
Wilberforce on the Holy Eucharist. 1853.
Wilkins' Concilia.
Williams, Isaac, on the Psalms.
Zaccaria, Bibliotheca Ritualis. 1776-81.

CHRONOLOGICAL TABLE.

	A.D.
Liturgy of Cassian and Leo [see p. 147]	circ. 420
Sacramentary of St. Leo	451
————— Gelasius	492
————— Gregory	590
St. Augustine's revised Liturgy of Britain [see pp. xvii. 147]	circ. 600
Salisbury Use of St. Osmund	1085
English Prymer. [Maskell's Mon. Rit. Ang. ii.]	circ. 1390
Liber Festivalis. [A book of mediæval English Homilies, printed by Caxton.]	1483
Salisbury Breviary reformed. [1st ed.]	1516
Mirror of our Lady. [A translation of and commentary on the daily Offices and the Mass.]	1530
Salisbury Breviary reformed. [2nd ed.]	1531
————— Missal —————	1533
English Psalters printed	1534—1540
Marshall's Prymer	1535
English Epistles and Gospels printed	1538—1548
Hilsey's Prymer	1539
The "Great Bible" set up in Churches as the "Authorized Version"	1540
Salisbury Use further reformed, and adopted (by order of the Convocation) throughout the Province of Canterbury	1541
Committee of Convocation commissioned to revise Service-books	1542—1549
English Litany ordered for use in Churches	June 11, 1544
King Henry the Eighth's Prymer	1545
Archbishop Hermann's Consultation [German, 1543; Latin, 1545], printed in English, 1547; reprinted	1548
Edward the Sixth's First Year	Jan. 28, 1546-7, to Jan. 27, 1547-8
English Order of Communion added to Latin Mass,—	
Brought before Convocation	Nov. 30, 1547
Taken into use	March 8, 1547-8
Book of Common Prayer. [First Book of Edward VI.]—	
Submitted to Convocation (by Committee of 1542-9)	Nov. 24, 1548
Laid before Parliament as part of Act of Uniformity [2 & 3 Edw. VI. c. 1] Dec. 9, 1548	
Passed by the House of Lords ditto	Jan. 15, 1548-9
————— Commons ditto	Jan. 21, 1548-9
Received Royal Assent. [Date not yet ascertained.]	
Published	March 7, 1548-9
Taken into general use	June 9, 1549
Edward the Sixth's Second Year	Jan. 28, 1547-8, to Jan. 27, 1548-9
English Ordinal	March, 1549-50

	A.D.
Book of Common Prayer. [Second Book of Edward VI.]—	
[Committee of Convocation commissioned, probably]	1551]
Passed through Parliament as part of Act of Uniformity [5 & 6 Edw. VI. c. 1]	Ap. 6, 1552
Ordered to be taken into use from	Nov. 1, 1552
Edward VI. died	July 6, 1553
Acts of Uniformity (including Prayer Books) repealed by 1 Mary, sess. ii., c. 2	Oct. 1553
Queen Elizabeth's Accession	Nov. 17, 1558
Edward VI.'s Second Book restored (with some alterations) by 1 Eliz., c. 2	June 24, 1559
Queen Elizabeth's Latin Book of Common Prayer	1560
Commission to revise Calendar and Lessons	Jan. 22, 1561
Hampton Court Conference	Jan. 14—18, 1603-4
Scottish Book of Common Prayer	1637
Prayer Book suppressed by "ordinance" of Parliament	Jan. 3, 1644-5
Use of Prayer Book revived	June, 1660
Savoy Conference	April 15—July 24, 1661
Book of Common Prayer [that now in use]—	
Commission to the Convocations to revise it	June 10, 1661
Revision completed by Convocations	Dec. 20, 1661
Approved by King in Council	Feb. 24, 1661-2
Passed House of Lords as part of Act of Uniformity [14 Car. II.]	April 10, 1662
Commons ditto	May 8, 1662
Received Royal Assent ditto	May 19, 1662
Taken into general use	Aug. 24, 1662
Adopted by Irish Convocation	Nov. 11, 1662
Standard copies certified under Great Seal	Jan. 5, 1662-3
Embodied in Irish Act of Uniformity [17 and 18 Car. II.]	June 18, 1666
William the Third's Commission to review Prayer Book	1689
Revised Calendar authorized by 24 Geo. II., c. 23	1752
American Book of Common Prayer	1785-9

AN

HISTORICAL INTRODUCTION

TO THE

PRAYER BOOK.

For more than two centuries the Book of Common Prayer has remained altogether unaltered, the last changes that were made in it being those which brought it into its present, and now venerable, form, in 1661. But the various stages of its development from the ancient formularies of the Church of England extended through a period of one hundred and fifty years; and the history of that development is of the highest importance to those who wish to understand and use the Prayer Book; as well as of considerable interest to all from the fact of its being an integral part of our national history.

The Church of England has had distinctive formularies of its own as far back as the details of its customs in respect to Divine Worship can be traced. The earliest history of these formularies is obscure, but there is good reason to believe that they were derived, through Lyons, from the great patriarchate of Ephesus, in which St. John spent the latter half of his life. There was an intimate connection between the Churches of France and England in the early ages of Christianity, of which we still have a memorial in the ancient French saints of our Calendar; and when St. Augustine came to England, he found the same rites used as he had observed in France, and remarks upon them as differing in many particulars from those of Rome. It is now well known that this ancient Gallican Liturgy came from Ephesus¹. But there can be no doubt that several waves of Christianity, perhaps of Apostolic Christianity, passed across our island; and the Ephesine or Johannine element in the ancient Prayer Books of the Church of England probably represents but the strongest of those waves, and the predominating influence which mingled with itself others of a less powerful character.

It was in the sixth century [A.D. 596] that the great and good St. Augustine^{St. Augustine and the old English Liturgy.} undertook his missionary work among the West Saxons. The mission seems to have been sent from Rome by Gregory the Great, under the impression that the inhabitants of England were altogether heathen; and if he or Augustine were not unacquainted with what St. Chrysostom, St. Jerome, and others had said respecting the early evangelization of Britain, they had evidently concluded that the Church founded in Apostolic times was extinct. When Augustine arrived in England, he found that, although the West Saxons were heathen, and had driven the Church into the highlands of Wales by their persecution, yet seven bishops remained alive, and a large number of clergy, who had very strong views about the independence of the Church of England, and were unprepared to receive the Roman missionary except on terms of equality. The chief difficulty felt by St. Augustine arose from the difference just referred to between the religious system of Rome (the only Church with which he was acquainted) and those of France and England. This difficulty, a great one to a man so conscientious and simple-minded, he submitted to Gregory in the form of questions, and among them was the following one on the subject of Divine Worship:—"Whereas the Faith is one, why are the customs of Churches various? and why is one manner of celebrating the Holy Communion used in the holy Roman Church, and another in that of the Gauls?" This diversity becomes even

¹ See Palmer's *Origines Liturg.*, i. 153. Neale and Forbes' *Gallican Liturgies*. Freeman's *Principles of Divine Service*, ii. 399.

more prominent in the words which Augustine addressed to the seven Bishops of the ancient Church of England, when they met in conference at the place afterwards called St. Augustine's Oak. "You act," said he, "in many particulars contrary to our customs, or rather, to the customs of the universal Church, and yet, if you will comply with me in these three points, viz. to keep Easter at the due time; to perform the administration of baptism, by which we are born again to God, according to the custom of the holy Roman and Apostolic Church; and jointly with us to preach the Word of God to the nation of the Angles, we will readily tolerate all your other customs, though contrary to our own." The answer of St. Gregory contained wise and Catholic advice; and to it we owe, under Providence, the continued use of an independent form of Divine Worship in the Church of England from that day to the present. "You, my brother," said Gregory, "are acquainted with the customs of the Roman Church in which you were brought up. But it is my pleasure that if you have found any thing either in the Roman or the Gallican or any other Church which may be more acceptable to Almighty God, you carefully make choice of the same; and sedulously teach the Church of the Angles, which is at present new in the Faith, whatsoever you can gather from the several Churches. For things are not to be loved for the sake of places, but places for the sake of good things. Select, therefore, from each Church those things that are pious, religious, and correct; and when you have made these up into one body, instil this into the minds of the English for their Use." [Greg. Opera, ii. 1151, Bened. ed.; Bede's Eccl. Hist. i. 27.] The Liturgy of the Roman Church spoken of in this reply is represented by the ancient Sacramentary of St. Gregory, to which such frequent references are given in the following pages: that of the Gallican Church is also extant¹, and has been shown (as was mentioned before) to be the Liturgy of the Church of Ephesus. The words "any other Church" might be supposed to refer to an independent English Liturgy, but there is no reference to any in the question to which Gregory is replying, and he evidently knew nothing of England except through Augustine. From other writers it seems that the Liturgy of England before this time, had been the same with that of France; but the native clergy always alleged that their distinctive customs were derived from St. John.

Being thus advised by St. Gregory, the holy missionary endeavoured to deal as gently as possible with those whose customs of Divine Worship differed from his own; but his prepossessions in favour of the Roman system were very strong, and he used all his influence to get it universally adopted throughout the country.

Uniformity in all details was not, however, attainable. The national feeling of the ancient Church steadily adhered to the ancient rite for many years; while the feeling of the Church founded by St. Augustine was in favour of a rite more closely in agreement with that of Rome. As collision was the first natural consequence of this state of things, so some degree of amalgamation as naturally followed in course of time; that which was local, or national, mingling with that which was foreign in the English devotional system, as it did in the English race itself. Some attempts were made, as in the Council of Cloveshoo [A.D. 747], to enforce the Roman Liturgy upon all the dioceses of the country, but it is certain that the previous devotional customs of the land had an exceedingly tenacious hold upon the clergy and the people, and that no efforts could ever wholly extirpate them².

At the time of the Conquest another vigorous attempt was made to secure uniformity of Divine Service throughout the country, and with the most pious intentions. Osmund, Bishop of Salisbury, and Chancellor of England, remodelled the Offices of the Church, and left behind him the famous Portiforium or Breviary of Sarum, containing the Daily Services; together with the Sarum Missal, containing the Communion Service; and, probably, the Sarum Manual, containing the Baptismal and other "occasional" Offices. These, and some other Service-books, constituted the "Sarum Use," that is, the Prayer Book of the Diocese of Salisbury. It was first adopted for that diocese in A.D. 1085, and was introduced into other parts of England so generally that it became the principal devotional Rule of the Church of England, and continued so for more than four centuries and a half: "the Church of Salisbury," says a writer of the year 1256, "being conspicuous above all other Churches like the sun in the heavens, diffusing its light every where, and supplying their defects." Other Uses continued to hold their place in the dioceses of Lincoln, Hereford, and Bangor, and through the greater part of the province of York; though in the diocese of Durham the Salisbury system was followed. At St. Paul's Cathedral, and perhaps throughout the

¹ See the names Menard, Muratori, and Mabillon, in the List of Authorities.

² See Maskell's Ancient Liturgy, Preface, p. liv.

diocese of London, there was an independent Use until A.D. 1414; and probably there were several others in Cathedral Churches, while the Roman system was adopted by most monasteries. The Salisbury Use, that of York, that of Bangor, and that of Hereford, are well known to modern ritualists. They appear to be traceable to a common origin; but they differ in so many respects from the Roman Breviary, and even from the Missal (with which a closer agreement might have been expected), that they clearly derive their common origin from a source independent of the Roman Church. And, whatever quarter they may have been derived from in the first instance, it is equally clear that the forms of Divine Service now known to us under these names represent a system which was naturalized so many ages ago that it has been entitled to the name of an independent English rite for at least a thousand years.

There are no means of deciding how far the original Use of Salisbury differed from that which is known to us. The copies remaining belong to a much later period than ^{Reformation of} the eleventh century, and there is reason to think that some accretions had gathered ^{the Sarum Use.} around the ancient devotions of the Church of England by that time. The tide of change by which these were to be removed began to set in a few years after the accession of Henry VIII., when a new edition of the Salisbury Portiforium was issued, perhaps under the influence of Cardinal Wolsey, whose efforts towards bringing about a Reformation have been too little recognized. This edition was printed in 1516; and is said by a modern learned Editor, the Rev. C. Seager, to have well deserved the name of a Reformed Breviary from the important changes which had been made in it¹. There was little variation indeed from the old forms; but there was a distinct initiation of the principles which were afterwards carried out more fully in the Book of Common Prayer of 1549. The rubrics were much simplified; Holy Scripture was directed to be read in order, without omission; and the Lessons were restored to their ancient length, which was about double of what they had been reduced to in some previous editions of the Breviary.

In 1531 this Reformed Edition of the Salisbury Portiforium or Breviary was reprinted; and two years later the Missal was published, reformed on the same principles; in the latter special care being taken to provide an apparatus for enabling the people to find out the places of the Epistles and Gospels. And though no authorized translation of the Bible had yet been allowed by Henry VIII., Cranmer and the other Bishops began to revise Tyndale's translation in 1534, and encouraged the issue of books containing the Epistles and Gospels in English, of which many editions were published between 1538 and the printing of the Prayer Book². A fresh impulse seems thus to have been given to the use of the old English Prymers, in which a large portion of the Services (including the Litany) was translated into the vulgar tongue, and also a third of the Psalms, and to which in later times the Epistles and Gospels were added. In 1530 also had been published an admirable commentary on some of the daily services (in which the greater part of them is translated into English), under the title of "The Mirroure of our Ladye," which furnishes a strong indication of the endeavours that were being made to render Divine Service intelligible to those who could not read Latin.

In 1540 the Psalter was printed by Grafton in Latin and English [Bodleian Lib., Douce BB. 71], and there seems to have been an earlier edition of a larger size about the year 1534. The Psalter had long been re-arranged, so that the Psalms were said in consecutive order, according to our modern practice, instead of in the ancient but complex order of the Breviary. [See *Introd. to Psalter.*]

In 1541 another amended, and still further reformed edition of the Salisbury Breviary was published, in the title-page of which it is said to be purged from many errors. By order of Convocation [March 3, 1541-2] this was adopted throughout the whole province of Canterbury, and an uniformity secured which had not existed since the days of Augustine. With this edition an order was also put forth that Lessons should be read in English after the Te Deum and Magnificat. Nor is it an insignificant circumstance that the book was now printed by Whitchurch (from whose press issued the Book of Common Prayer), instead of being printed in Paris as formerly.

The ancient formularies had, however, by change of circumstances, become unsuitable in several respects for the Church of England. They had grown into a form in which they were extremely well adapted (from a ritual point of view) for the use of religious communities, but were far too complex for that of parochial congregations. When monasteries were abolished, it was found that the devotional system of the Church must be condensed if it was to be used by mixed congregations, and by those

¹ Portiforium Sarisb., p. vii. Leslie, 1843.

² See List of Printed Service-books, according to the ancient

uses of the English Church. Compiled by Mr. F. H. Dickinson. Masters. Reprinted from *Ecclesiologist* of Feb. 1850.

who were not specially set apart for that life of rule and continual worship for which monastic communities were intended. The Breviary services had never been familiar to the people of England, any more than they are to the Continental laity of the present day. They were accretions around some shorter and more primitive form of responsive public service which had been found insufficient for those who formed themselves into special societies for the purpose of carrying on an unceasing round of prayer and praise. But now that the "religious" of the Church were to be so separated no longer, Divine Providence led her to feel the way gradually towards a return to the earlier practice of Christianity; the idea of a popular and mixed congregation superseded that of a special monastic one; and the daily worship being transferred from the Cloister to the Parish Church, its normal form of Common Prayer was revived in the place of the Prayers of a class or the solitary recitation of the Parish Priest. No blame was cast upon the former system for its complexity; but the times were changed, a new order of things was becoming established, and, although the *principles* of the Church are unchangeable, so entire a remoulding of society entailed of necessity a corresponding adaptation of her devotional *practice*, both for the honour of God and the good of souls, to the wants that had come to light.

That such was really the object of the steps which were taken towards a Reformed English Breviary or Portiforium is confirmed by the course of events. Something in the nature of a confirmation is also afforded by a comparison of these attempts with others of a similar kind which were made abroad towards obtaining a Reformed Roman Breviary. Some years after the Convocation of the Church of England had issued the 1516 edition of the Salisbury Use, Leo X. gave directions to Zaccharie Ferréri de Vicence, Bishop of Guarda, in Portugal, to prepare a new version of the Breviary Hymns. This was done, and the volume published under the authority of Clement VII. in 1525, with this prominent announcement of a Reformed Breviary on the title-page:—"*Breviarium Ecclesiasticum ab eodem Zach. Pont. longe brevius et facilius redditum et ab omni errore purgatum propediem eribit.*" The promised reform was effected by Cardinal Quignonez, a Spanish Bishop, and was published under the same authority as the Hymnal, in 1535-6. But this Reformed Roman Breviary was intended chiefly, if not entirely, for the use of the clergy and monks in their private recitations; and its introduction in some places for choir and public use eventually led to its suppression in 1568. No provision whatever was made (as there had been in connexion with the English reform) for adapting it to the use of the laity. During the whole forty years of its use there is no trace of any attempt to connect the Breviary of Quignonez with vernacular translations of prayers or scriptures. And, although it was undoubtedly an initiatory step in the same direction as that taken by our own Reformers (who indeed used the Breviary of Quignonez in their subsequent proceedings), yet it was never followed up, nor intended to be followed up; and the object of the Roman reform throws out in stronger light that of the English.

The measures already taken by the ecclesiastical authorities of England were plainly regarded as being of a temporary nature only. No more Service-books were allowed to be printed than were absolutely necessary for the performance of Divine Worship, as it was seen that a much more thorough revision of them must take place. Meanwhile, a Committee of Convocation was appointed, with the sanction of Henry VIII., to consider the nature of the revision that was to be made. This Committee was appointed in 1542, and consisted of the Bishops of Salisbury¹ and Ely (Shaxton and Goodrich), with six Clergy of the Lower House of Convocation; the object of their appointment being stated to be the examination, correction, and reformation of "all mass-books, antiphoners" [anthen-books], "and portuises," that is *portiforia*, or breviaries. This Committee continued in existence for a long period, and its last work was the Book of Common Prayer, published in 1549. But for a time its public action was restrained by the "Statute of Six Articles," which, in point of fact, made such labours highly penal². There is good reason to think that Henry VIII.

¹ The Bishops of Salisbury are *ex officio* Precentors of the Province of Canterbury.

² The Statute of Six Articles was an Act of Parliament passed under the personal influence of Henry VIII., and against the persevering efforts of the Bishops in the House of Lords, in the year 1539. It made highly penal any denial of either of six short statements which embodied the chief points of doctrine then brought into controversy. It formed the key of the position for the time; and, knowing this, Cranmer and other Bishops maintained the debate for eleven days in the hope of preventing

the bill from passing, he himself arguing against it for three days. The penalties annexed to this Act were, for preaching or writing against the first article, burning (without pardon on recantation); imprisonment for life, with forfeiture, for preaching or writing against any of the others, with death for the second offence. In his reply to the Devonshire rebels, Archbishop Cranmer writes respecting this statute (which they wished to have restored), "If the King's Majesty himself had not come into the parliament house, those laws had never passed."—Strype's Cranmer, ii. 515. Ecc. Hist. Soc.

was himself the author of this Statute, and it was certainly passed by his influence. The Bishops had vigorously opposed it in the House of Lords with an eleven days' debate, and their experience showed them that any reformation of the ancient services must be carried on with extreme caution while this law was in operation under so despotic a monarch¹. But as soon as Convocation met, after the death of Henry, a resolution was passed, "That the works of the Bishops and others, who by the command of the Convocation have laboured in examining, reforming, and publishing the Divine Service, may be produced, and laid before the examination of this house." This resolution was passed on November 22nd, 1547, and as some of the Clergy complained that it was not safe to do this while the Statute of Six Articles remained in force, Cranmer exerted himself, and successfully, to get it repealed, and so to set the Committee and the Convocation free.

The first efforts of the Committee had been to prune down the complexity and ^{Reform of the} superabundance of the existing Rubrics. This was so great that some pages of the ^{Rubrics.} Service-books contained many more words of direction in red letters than of prayers in black. The whole ceremonial of Divine Service was involved in this inquiry, including the ancient and venerable practices of the Church, as well as numberless recent and often superstitious ones. In 1543 they prepared a long Canon on "The Ceremonies to be used in the Church of England, together with an explanation of the meaning and significancy of them." How far this was published at the time is not clear; but it is highly probable that the investigation which resulted in this document was also the foundation on which the Rubrics of 1549 were constructed.

The reconstructors of our devotional offices acted wisely in reducing the number of Rubrics, and generally moderating the ceremonial system of the Church of England. They said that "the great excess and multitude of them hath so increased in these latter days, that the burthen of them was intolerable," and they spoke with the experience of practical men, who were familiarly acquainted all their lives with that about which they wrote. But one inconvenience has arisen out of the manner in which they did their work, from which later generations have suffered more than they could foresee. They went upon the principle of expressing only the most essential things in the Rubric, and left many others to tradition. As Bishop Cosin states it², "The book does not every where enjoin and prescribe every little order, what should be said or done, but takes it for granted that people are acquainted with such common, and things always used already." Many of these usages are referred to in the subsequent pages of this volume, and need not be mentioned now. It is sufficient to say, that some of them dropped out of memory altogether during the persecution of the Church and the suppression of the Establishment under the rule of the Commonwealth; that others, from want of written authority, have become the subject of controversy; and that the ritual tradition to which the Reformers trusted so much when they put forth their condensed form of Rubric, has only been partially recovered even in our own time.

Meanwhile they had also set forth, in 1544, the Litany in English, revised from the old English Litany, which had been in use for a hundred and fifty years or more, and with additions from the Litany of Luther, and that of Archbishop Hermann's Reformed Ritual of Cologne. Though, however, the King consented to this, he seems to have refused to sanction any further labours of the Committee, and they were obliged to proceed with extreme caution during the remainder of his life.

Freedom of action for the Bishops and Clergy of Convocation having been obtained ^{Enlargement of} by the repeal of the Statute of Six Articles (or the "Whip with Six Cords," as it was ^{the Committee.} grimly called), they immediately commenced advancing to the practical end of the Revision which had been in view for so many years. On November 30th, 1547, Archbishop Cranmer (now a member of this important Committee) brought before Convocation "a form of a certain ordinance for the receiving of the Body of our Lord under both kinds, viz., of bread and wine." This was adopted,

¹ Yet Cranmer made a vigorous effort to persuade the king into authorizing the publication of their revision. On January 24, 1546, he sent Henry a draught of a letter to be addressed to himself by the king, in which it is referred to, and by which it was intended to put it in force. But the king would not adopt the suggestion. The Archbishop wisely pressed on these proposed reforms in the hope that they would be firmly rooted, if established by so vigorous a hand as that of Henry VIII. "It was better," he said to his Secretary in 1547, "to attempt such

reformation in King Henry the Eight his days than at this time, the king being in his infancy. For if the king's father had set forth any thing for the reformation of abuses, who was he that durst gainsay it?" He probably foresaw that there would be Roman and Puritan schisms, and thought that they might have been prevented by the Church, when backed by the concentrated power of Henry, while there was little hope of stemming their force under his successors.

² Works, vol. v. p. 65.

and published in March under the title of "The Order of the Communion," being an English addition to the ancient Salisbury Use of the Missal, which was left otherwise untouched. [See Notes on Communion Service.]

The Committee of Revision had now been considerably enlarged, and since it occupies so important a position in respect to the subsequent history of England, it will be well to give their names as they stood in 1547-8, and in 1549.

From the Upper House of Convocation.

Thomas Cranmer	Archbishop of Canterbury.
Thomas Goodrich	Bishop of Ely [afterwards Lord Chancellor].
Henry Holbech (or Randes)	Bishop of Lincoln.
George Day	Bishop of Chichester.
John Skip	Bishop of Hereford.
Thomas Thirlby	Bishop of Westminster.
Nicholas Ridley	Bishop of Rochester [afterwards of London].

From the Lower House of Convocation.

William May	Dean of St. Paul's.
Richard Cox	Dean of Ch. Ch. [afterwards Bishop of Ely.]
John Taylor	Dean of Lincoln [afterwards Bishop of Lincoln].
Simon Heynes	Dean of Exeter.
Thomas Robertson	Archdeacon of Leicester [afterwards Dean of Durham].
John Redmayne	Master of Trin. Coll. Camb.

In what manner the Convocation of the Province of York was represented is not on record; but from the proceedings of 1661 (which would be founded on strict precedent) there can be no doubt that its co-operation was obtained in some way; and the names of the Archbishop of York and his Suffragans are indeed contained in a list of Bishops who were indirectly or directly mixed up with those above recorded.

It is evident there had been a conviction all along that it was necessary to adopt the "vulgar tongue" as the language in which the revised Services of the Church of England were to be used. The English Litany, which had been used by the people for many generations, was authorized for public use in Divine Service in 1544. The Processional (containing other Litanies) was translated in the same year, though never brought into use; and the "Order of Communion" was a step in the same uniform direction of progressive reformation. Much interesting light is thrown on the manner in which this cautious progress was made, by a letter of Archbishop Cranmer to Henry VIII., respecting the English Processional just referred to: its date being Oct. 7, 1544¹:—

"It may please your Majesty to be advertised, that, according to your Highness' commandment, sent unto me by your Grace's Secretary, Mr. Pagett, I have translated into the English tongue, so well as I could in so short a time, certain processions, to be used upon festival days, if after due correction and amendment of the same, your Highness shall think it so convenient. In which translation, forasmuch as many of the processions, in the Latin, were but barren, as me seemed, and little fruitful, I was constrained to use more than the liberty of a translator: for in some processions I have altered divers words; in some I have added part; in some taken part away; some I have left out whole, either for bycause the matter appeared to me to be little to purpose, or bycause the days be not with us festival days" [having been abrogated in 1537]; "and some processions I have added whole, because I thought I had better matter for the purpose than was the procession in Latin; the judgement whereof I leave wholly unto your Majesty: and after your Highness hath corrected it, if your Grace command some devout and solemn note to be made thereunto (as is to the procession which your Majesty hath already set forth in English), I trust it will much excitate and stir the hearts of all men unto devotion and godliness. But in mine opinion, the song that shall be made thereunto should not be full of notes, but as near as may be for every syllable a note; so that it may be sung distinctly and devoutly, as, be the

¹ Jenkyns' Cranmer, i. 315.

Matins and Evensong, *Venite*, the Hymns, *Te Deum*, *Benedictus*, *Magnificat*, *Nunc Dimittis*, and all the Psalms and Versicles; and in the Mass, *Gloria in Excelsis*, *Gloria Patri*, the Creed, the Preface, the *Pater Noster*, and some of the *Sanctus* and *Agnus*. As concerning the *Salve festa dies*, the Latin note, as I think, is sober and distinct enough; wherefore I have travailed to make the verses in English, and have put the Latin note unto the same. Nevertheless, they that be cunning in singing, can make a much more solem note thereto. I made them only for a proof, to see how English would do in song. But by cause mine English verses lack the grace and facility that I would wish they had, your Majesty may cause some other to make them again, that can do the same in more pleasant English and phrase. As for the sentence" [the English sense], "I suppose it will serve well enough. Thus Almighty God preserve your Majesty in long and prosperous health and felicity. From Bekisbourne, the 7th of October.

"Your Grace's most bounden

"Chaplain and Beadsman,

"T. CANTUARLEN.

"To the King's most excellent Majesty."

From other transactions between the Archbishop and the King, it may be inferred that the suggestion was first sent by the former, perhaps at the request of Convocation, to the latter, then returned in the form of an order from the Crown to the Archbishop as head of the Convocation; and that the above letter is the official reply to that order. It does not appear that the King permitted this English Processional to be published. The *previous* Procession alluded to by Cranmer in this Letter was the Litany nearly as it is now used, which was ordered to be sung in English (as it had long been known to the people through the Prymers) by a mandate of the Crown, dated June 11, 1544¹.

It had always, in fact, been the practice of the Church of England to encourage and promote the intelligent use of her services by the people at large: and in this, perhaps, she has always differed considerably from other European churches². From the earliest periods we find injunctions imposed upon the Clergy that they should be careful to teach the people the Creed, the Lord's Prayer, and the Ten Commandments in their own tongue. Thus, in A.D. 740 there was an excerpt of Egbert, Archbishop of York, to the effect, "that every priest do with great exactness instil the Lord's Prayer and Creed into the people committed to him, and shew them to endeavour after the knowledge of the whole of religion, and the practice of Christianity³." About the same time, in the southern Province, it is ordered "that they instil the Creed into them, that they may know what to believe, and what to hope for⁴." Two centuries later there is a canon of Ælfric, Archbishop of Canterbury, enjoining the clergy to "speak the sense of the Gospel to the people in English, and of the Pater noster, and the Creed, as oft as he can, for the inciting of the people to know their belief, and retaining their Christianity⁵." Similar injunctions are to be found in the laws of Canute in the eleventh century, the constitutions of Archbishop Peckham in the thirteenth, and in the canons of many diocesan synods, of various dates in the mediæval period. Many expositions of the Creed, Lord's Prayer, Ten Commandments, and other principal formulæ are also to be found in English, and these give testimony to the same anxious desire of the Church to make the most use possible of the language spoken by the poor of the day⁶. Inter-linear translations of some, at least, of the offices, were also provided, just as the English and Welsh Prayer Book is printed in parallel columns in modern times.

But in days when books were scarce, and when few could read, little could be done towards giving to the people at large this intelligent acquaintance with the services except by oral instruction of the kind indicated. Yet the writing-rooms of the Monasteries did what they could towards multiplying books for the purpose; and some provision was made, even for the poorest, by means of Horn-books, on which the Lord's Prayer, the Creed, and the Angelic Salutation were written. The following

¹ The Salisbury Processional was republished in Latin some time in 1544, probably because the king would not consent to have it used in English as proposed by Cranmer.

² One chief reason of this difference is doubtless to be found in the fact that the Latin language was spoken almost, if not quite, vernacularly in France, Spain, Portugal, and Italy, to a late period, as it is now in Hungary: and that the modern languages of these countries were formed out of it. In England Latin was never vernacular, and it furnished only a small part of our settled

English. Yet it was very commonly understood in mediæval times.

³ Johnson's Eng. Canons, i. 186.

⁴ Ibid. 248.

⁵ Ibid. 398.

⁶ It must be remembered that English was not spoken universally by the upper classes for some centuries after the Conquest. In 1362, an Act of Parliament was passed, enjoining all schoolmasters to teach their scholars to translate into English instead of French.

is an engraving made from one of two which were found by the present writer under the floor of Over Church, near Cambridge, in 1857. It is of a late date, and has had "In the Name of the Father, and of the Son, and of the Holy Ghost," in the place of the Angelic Salutation; but it is given as an illustration of the traditional practice, and because it is of special interest from being found in a church.



While these horn-books were thus provided for the poor, the Scriptorium of the Monastery also provided Prymers in English and Latin for those who could afford the expensive luxury of a book. The Latin Prymers are well known under the name of "Books of Hours." Vernacular Prymers exist which were written as early as the fourteenth century, and many relics of old English devotion of that date will be found in the following pages of this volume. These English Prymers contained about one-third of the Psalms, the Canticles, the Apostles' Creed, with a large number of the prayers, anthems, and perhaps hymns. They continued to be published up to the end of Henry VIII.'s reign; and, in a modified form, even at a later date: and they must have familiarized those who used them with a large portion of the Services, even when they did not understand the Latin in which those services were said by the Clergy and choirs.

Books were also provided in which were given tables of reference to the Lessons, Epistles, and Gospels. The following is the title of one, and a specimen of the references is annexed:—

"Here begynneth a rule that tellith in whiche chapitris of the bible ye may fynde the lessouns, pistlis and gospels, that ben red in the churche aftir the vse of salisbury: markid with lettris of the a. b. c. at the begynnyng of the chapitris toward the myddil or eende: aftir the ordre as the lettris stonden in the a. b. c. first ben sett sundaies and ferials togidere: and aftir that the sanctorum, the propre and comyn togider of al the yeer: and thanne last the commemoraciouns: that is clepid the temporal of al

the yere. First is written a clause of the begynnynge of the pistle and gospel, and a clause of the endynge therof."

"The first sonenday } Rom. xiii. c. | *d.* we knowen this tyme. | *ende.* in the lord Ihs Ct.
of aduent. } Mattheu. xxi. c. | *a.* whanne ihs cam nygh. | *ende.* osanna in high thingis."

Such provisions for the accompaniment of the Latin Service went a good way towards rendering it intelligible to those who could read. Nor must we omit to mention the sermons for Christian Seasons, and on the elements of Christian Faith and Practice, which went under the name of the "Festivale" or "Liber Festivalis." These were printed by Caxton in 1483, and often reprinted between then and the time when our present Homilies and other books of the kind were set forth¹.

Soon after the accession of Edward VI., which occurred in January 1546-7, a Visitation of all the Dioceses of England was commenced, and the well-known "Injunctions of Edward VI." were printed on July 31st, 1547. In May of the same year a King's letter² was sent to the Archbishops, giving notice of an intended Visitation, and in October some other Injunctions were issued by the Royal Visitors, which appear never to have been printed. They are here copied (with the exception of the last three, which have no bearing on our subject) from Fothergill's MS. Collections in York Minster Library³.

"Injunctions given by the King's Majestie's Visitors in his Highness' Visitation to Robt. Holdgate Ld. A. B. the Dn. Chapter, and all other the Ecclesiastical ministers of and in the Cathedral Church of York, 26 8bris. An. 1547.

[1] "Ye shall at all days and times when nine lessons ought or were accustomed to be sung, sing Mattins only of six Lessons and six Psalms with the song of Te Deum Laudamus or Miserere, as the time requireth, after the six Lessons: and that dayly from the Annunciation of our Lady to the first day of October ye shall begin Mattins at six of the clock in the morning, and residue of the year at seven of the clock.

[2] "*Item.* Ye shall sing and celebrate in note or song within the said Church but only one Mass, that is to say, High Mass only, and none other, and daily begin the same at nine of the clock before noon.

[3] "*Item.* Ye shall daily from the said feast of the Annunciation to the said first day of October, sing the Evensong and Complin without any responds: and begin the same at three of the clock in the afternoon. The residue of the year to begin at two of the clock, or half an hour after.

[4] "*Item.* Ye shall hereafter omit, and not use the singing of any hours, prime, dirige, or commendations; but every man to say the same as him sufficeth or he is disposed.

[5] "*Item.* Ye shall sing, say, use, or suffer none other Anthems in the Church but these hereafter following, and such as by the King's Majesty and his most Honourable Council hereafter shall be set forth.

Anthem.

"Like as Moses lift up the serpent in the wilderness, even so was our Saviour Jesus Christ lift upon the Cross, that whosoever believeth in Him should not perish, but have joy for ever. For God so loved

¹ The necessity for a vernacular Service is strongly asserted in the Preface to the edition of the Prymer [A.D. 1545] which goes by the name of "the King's," though probably the king had nothing to do with it further than signing an order for its publication. It is there declared, "The party that understandeth not the pith and effectualness of the talk that he frankly maketh with God, may be as an harp or pipe having a sound, but not understanding the noise that itself hath made;" and the king is then made to say that he has given to his subjects "a determinate form of praying in their own mother-tongue, to the intent that such as are ignorant of any strange speech, may have what to pray in their own acquainted and familiar language with fruit and understanding." But the credit thus given to the king was given in the adulatory spirit of the age. Such books had long

been provided for the laity by the Clergy, but they were now to be issued under royal authority: and it would have been more honest to have said how the case really stood. After his condemnation, Archbishop Cranmer wrote, in a letter to Queen Mary, that the Revision Committee, though composed of men who held different opinions, "agreed without controversy (not one saying contrary) that the Service of the Church ought to be in the mother tongue." Ridley also writes to his chaplain that he had conferred with many on the subject, and "never found man (so far as I do remember), neither old nor new, gospeller nor papist, of what judgment soever he was, in this thing to be of a contrary opinion."

² Cardwell's Doc. Ann., i. 24.

³ Probably they were issued for the southern Province also.

the world, that He gave His only-begotten Son, that such as believe in Him should not perish, but have life everlasting.

“ V. Increase, O Lord, our faith in Thee.

“ R. That we may work His pleasure only.

Collect.

Let us pray.

“ Most bountiful and benign Lord God, we, Thy humble servants, freely redeemed and justified by the passion, death, and resurrection of our Saviour Jesus Christ, in full trust of salvation therein, most humbly desire Thee so to strengthen our faith and illuminaate us with Thy grace, that we may walk and live in Thy favour, and after this life to be partakers of Thy glory in the everlasting kingdom of Heaven, through our Lord Jesus Christ. So be it.

Another Anthem.

“ Be it evident and known unto all Christians that through our Lord Jesus Christ forgiveness of sins is preached unto you, and that by Him all that believe are justified from all things from the which we could not be justified by the law of Moses. So be it.

“ V. O Lord, for Christ's sake our Saviour.

“ R. Accept and hear our humble prayer.

Let us pray.

“ We sinners do beseech Thee, O Lord, to keep Edward the sixth, Thy Servant, our King and Governor; that it may please Thee to rule his heart in Thy faith, fear, and love; that he may ever have affiance in Thee, and ever seek Thy honour and glory. That it may please Thee to be his defender and keeper, giving him the victory over all his enemies, through our Lord Jesus Christ. So be it.

“ The residue of the day ye shall bestow in virtuous and godly exercises, as in study and contemplation of God His most holy word.

“ All which and singular Injunctions before mentioned the Lord Archbishop of this Church, his Chancellor, Archdeacons, or Official, shall publish and send, or cause to be published and sent and observed in to every Church, College, Hospital, and other ecclesiastical places within his Diocese.

[6] “ *Item.* All Sermons, Collations, and Lectures of Divinity hereafter to be had or made in visitations, Synods, Chapters, or at any other time or place, shall not be used in the Latin Tongue, but in the English, to the intent that every man having recourse thereunto may well perceive the same.”

These remarkable Injunctions have quite the appearance of taking up the reform of the Liturgy exactly where it had been laid down through the refusal of Henry VIII. to sanction the English Processional: for what are here called “ Anthems ” are exactly similar in character to those parts of the Service which were printed for each Festival in the Latin Processional of Salisbury, the variable part of the Litany, by which it was adapted to the different seasons of the Christian year. They were also used in the “ Hours,” and seem to show the original form of the “ Anthem ”.

But all sound reasons for offering up the praises and prayers of the Church in Latin had really passed away many years before this. The reverent prejudices which had still held men to the old habit were also dying off; and the time had arrived when the English language could with wisdom be wholly adopted by the English Church in her work of Divine Service.

No records have yet been discovered which throw any light upon the details of the Committee's work in producing the Prayer Book of 1549. It appears to have occupied them for several months, notwithstanding their previous labours; and there is every mark of deliberation and reverence in the result. The foundation of their work, or rather the quarry out of which they extracted their chief materials, was the Reformed Salisbury Use of 1516 and 1541: but some other books were evidently used by them, and it may be safely concluded that they did not end their labours before they had gone through a large amount of liturgical research. The

¹ See also the Easter Processional Anthem at p. 105.

following list may be taken as fairly representing the principal books which the Committee of Convocation had before them as the materials for their work of revision :—

- The Salisbury Portiforium¹, Missal, Manual, and Pontifical.
- The York and other Uses².
- The Reformed Breviary of Cardinal Quignonez. 1535-6³.
- Simplex ac Pia Deliberatio* of Hermann, Archbishop of Cologne. 1545⁴.
- The same in English. 1548⁵. (A previous edition also in 1547.)
- The Prymer in English, of various dates⁶.
- The "Great" Bible⁷.

How far the Book of Common Prayer was influenced by these works will be shown in the margin and the foot-notes of the following pages. But even a superficial glance at the latter will make it apparent that the new book was, substantially, as it still remains, a condensed reproduction, in English, of those Service-books which had been used in Latin by the Church of England for many centuries before.

The Reformation in Germany was in active progress at this time (not having yet lost the impetus given to it by the strong-handed leadership of Luther), and Cranmer had been much in correspondence with Melancthon and some other German divines during the reign of Henry VIII. But these foreign reformers had scarcely any influence upon the Prayer Book of 1549; and were probably not even consulted during its progress towards completion. Melancthon and Bucer assisted the Archbishop of Cologne in preparing his "Consultation" (one of the books referred to), and they probably used Luther's version of the ancient Nuremberg offices. But this volume contributed little to our Prayer Book beyond a few clauses in the Litany, and some portions of the Baptismal Service; and it is somewhat doubtful whether in the case of the Litany our English form was not in reality the original of that in Hermann's book. Most likely the latter was translated and brought before Convocation with the hope that it would have much influence; but the Committee of Revision were too wise and too learned in Liturgical matters to attach much importance to it⁸.

It is, in some respects, unfortunate that we cannot trace the book of 1549 into any further detail during the time when it was in the hands of the Committee. We cannot even form any definite conjecture as to the parts respectively taken by its members in the work before them; nor can one of the original collects which they inserted be traced back to its author. And yet there is some satisfaction in this. The book is not identified with any one name, but is the work of the Church of England by its authorized agents and representatives; and as we reverence the architects of some great cathedral for their work's sake, without perhaps knowing the name of any one of them, or the portions which each one designed, so we look upon the work of those who gave us our first English Book of Common Prayer,

¹ "Breviarium sen Portiforium secundum Morem et Consuetudinem Ecclesie Sarisburiensis Anglicane." It is called "*Salisbury Use*" in the Preface of our Prayer Book; and that term, or *Sarum Use*, is adopted generally for the Breviary, Missal, and other Service-books of the same origin.

² Referred to in the Prayer Book Preface, as "*Hereford Use, the Use of Bangor, York Use, and Lincoln Use.*"

³ "Breviarium Romanum, ex sacra potissimum Scriptura, et probatis Sanctorum historiis nuper confectum, ac denuo per eundem Anthorem accuratius recognitum, eaque diligentia hoc in anno a mendis ita purgatum, ut Momi iudicium non pertimescat. Lugduni. 1543."

⁴ "Simplex ac pia deliberatio de Reformatione Ecclesiarum Electoratus Coloniensis."

⁵ "A simple and religious consultation of us Hermann by the grace of God Archbishop of Colone and Prince Elector, &c., by what meanes a Christian reformation, and founded in God's worde, Of doctrine, Administration of Divine Sacraments, Of Ceremonies, and the whole cure of soules, and other ecclesiastical ministries, may be begun among men until the lord graunte a better to be appoynted, either by a free and christian counsaile, generall or national, or else by the states of the Empire of the nation of Germany, gathered together in the Holy Ghost. Perused by the translator thereof and amended in many places.

1548. Imprinted at London by Jhon Daye and William Seres dwellynge in Sepulchre's paryshe at the signe of the Resurrection, alytle aboue Holbourne Conduit. Cum gratia et privilegio imprimendum solum."

⁶ See Maskell's "*Monumenta Ritualia Ecclesie Anglicane*," vol. ii.; and Burton's "*Three Primers of Henry VIII.*"

⁷ "The Byble in Englyshe, that is to saye, the content of all the holy scripture bothe of ye olde and newe testament, truly translated after the veryte of the Hebrue and Greke textes, by ye dylygent studye of diverse excellent learned men, expert in the forsayde tonges. Printed by Rychard Grafton and Edward Whitechurch. Cum privilegio ad imprimendum solum. 1539."

⁸ It may be added that Cranmer had married a niece of Osiander, who is said to have prepared the Nuremberg formularies for Luther, and who was also the original compiler of a Catechism for Nuremberg and Brandenburg, of which that of Justus Jonas is a Latin translation. John à Lasco is said to have had some influence with Cranmer, and he certainly lived with the Archbishop at Lambeth from September to February in the year 1548-9. But the Prayer Book was before Parliament on December 9th, 1548-9, and was before the King in Council previously. It passed the Lords on January 15th, and the Commons on the 21st. Foreigners were very forward in interfering, but their suggestions were civilly put aside at this time.

admiring its fair proportions, and the skill which put it together, and caring but little to inquire whose was the hand that traced this or that particular compartment of the whole.

Although we cannot thus trace out the work of each hand in this great undertaking, we can, however, by means of internal evidence, and a comparison with the older formularies, find out the nature of their labours, and something of the manner in which they went about them. It was made a first principle that every thing in the new Prayer Book was to be in English; a principle respecting which, as has been shown before, there seems to have been not the slightest doubt or hesitation. Their first labour was, then, that of condensing the old services into a form suitable for the object in view, and yet keeping up the spirit and general purpose of the original and ancient worship of the Church.

[1] A great step was made in this direction by substituting a Calendar of Lessons referring to the Holy Bible for the Lessons at length as they had been hitherto printed in the Breviary. This made it possible to combine the Breviary [daily services], the Missal [Holy Communion], Epistles and Gospels (&c.), and the Manual [Occasional Offices], in one volume. A precedent for this was offered by a practice which had been adopted in the fifteenth century of printing the Communion Service (though not the Epistles and Gospels) as part of the Breviary¹. The Marriage Service was also printed in the Missal, which was a precedent for introducing the other services of the Manual into the Prayer Book.

[2] The next step towards condensation was the adoption of a less variable system in the daily services, so that the Collect of the day, the Lessons, and the Psalms should be almost the only portions of Mattins and Evensong which needed to be changed from day to day, or week to week.

[3] Lastly, the several hours of Prayer were condensed into two, Mattins and Evensong, with a third added on Sundays, Wednesdays, and Fridays, in the form of the Litany. The ancient arrangement of the day for Divine Service was as follows:—

Nocturns or *Mattins*; a service before daybreak.

Lauds; a service at daybreak, quickly following, or even joined on to, Mattins.

Prime; a later morning service, about six o'clock.

Tierce; a service at nine o'clock.

Sexts; a service at noon.

Nones; a service at three o'clock in the afternoon.

Vespers; an evening service.

Compline; a late evening service, at bedtime.

These services were often, if not generally, "accumulated" in the Mediæval Church as they are at the present day on the Continent; several being said in succession, just as Mattins, Litany, and the Communion Service have been "accumulated," in modern times, in the Church of England. But the different offices had many parts in common, and this way of using them led to unmeaning repetitions of Versicles and Prayers. This evil was avoided by condensing and amalgamating them, so that repetitions took place only at the distant hours of Morning and Evening. The services of Mattins, Lauds, and Prime, were thus condensed into Mattins; those for Vespers and Compline into Evensong. The three other hours appear (from a table of Psalms given in the Introduction to the Psalter) to have fallen out of public use long before the reformation of our offices; and they were probably regarded as services for monastic and private use only². The general result of this process of condensation will be best seen by the following table, in which the course of the ancient Mattins, Lauds, and Prime, is indicated side by side with that of the Mattins of 1549; and in the same manner, Vespers and Compline are set parallel with Evensong. From this comparison it will be clearly seen that the Book of Common Prayer was framed out of the ancient Offices of the Church of England, by consolidation and translation of the latter, the same principles which have been above indicated being also extended to the Communion Service and the Occasional Offices. The details of the changes that were made will be found in the notes under each portion of the Prayer Book in the following pages.

¹ So in Sarum Breviaries of 1499, 1507, 1510, 1514, 1535, | ² See also No. 4 of the Injunctions which are printed on
1541. B. Mus. and Bodleian Libraries. | page xxv.

§ *Sarum Daily Services and those of 1549.*

Salisbury Use.			Prayer Book of 1549.
Mattins.	Lauds.	Prime.	Mattins.
Invocation. Our Father. O Lord, open Thou. O God, make speed. Glory be. Alleluia. Venite, exultemus. Hymn. Psalms. Lessons. Te Deum.	Y. and R. O God, make speed. Glory be. Alleluia. Psalms. Canticle. Short chapter. Hymn. Benedictus. Suffrages. 1st Collect. 2nd Collect.	Invocation. Our Father. O God, make speed. Glory be. Alleluia. Hymn. Psalms. Athanasian Creed. Short chapter. Short Litany. Our Father. [Creed,] Suffrages, Con- fession and Absolution. 3rd Collect. Intercessory Prayers.	Our Father. O Lord, open Thou. O God, make speed. Glory be. Alleluia. Venite, exultemus. Psalms. 1st Lesson. Te Deum or Benedicite. 2nd Lesson. Benedictus. Creed. Short Litany. Our Father. Suffrages. 1st Collect. 2nd Collect. 3rd Collect.
	Vespers.	Compline.	Evensong.
	Invocation. Our Father. O God, make speed. Psalms. Short chapter. Hymn. Magnificat. Short Litany. Our Father. Suffrages. 1st Collect. 2nd Collect.	Invocation. Our Father. O God, make speed. Psalms. Short chapter. Hymn. Nunc Dimittis. Short Litany. Our Father. Suffrages, [Creed,] Con- fession and Absolution. 3rd Collect. Intercessory Prayers.	Our Father. O God, make speed. Psalms. 1st Lesson. Magnificat. 2nd Lesson. Nunc Dimittis. Creed. Short Litany. Our Father. Suffrages. 1st Collect. 2nd Collect. 3rd Collect.

When these learned Divines had completed their work, the Prayer Book was submitted to Convocation (which met on November 24th, 1548), that it might go forth with the full authority of the Church. It was then communicated to the King in Council, and afterwards laid before Parliament on December 9th, 1548, that it might be incorporated into an Act of Parliament [2nd and 3rd Edw. VI. cap. 1]. This Act (including the Prayer Book) passed the House of Lords on January 15th, and the House of Commons on January 21st, 1548-9. It was the first Act of Uniformity, and it enacted that the Prayer Book should come into use in all churches on the Feast of Whitsunday following, which was June 9th, 1549. The Book itself was published on March 7th, 1548-9, thus allowing three months' interval, during which the Clergy and Laity might become acquainted with the new Order of Divine Service.

Yet, although it was in one sense new, they who had been engaged upon it felt so strong a conviction that it was substantially identical with the old, that in after days Cranmer offered to prove that "the order of the Church of England, set out by authority of Edward the Sixth, was the same that had been used in the Church for fifteen hundred years past¹."

In the Act of Parliament which enacted the Book of Common Prayer, it was said to have been composed under the influence of the Holy Ghost; and there is, doubtless, an indication of this belief in the choice of the day on which it was enjoined to be used. So solemn were the views which those who arranged and set forth the Prayer Book took of their work, so anxious their desire that it should be sealed with the blessing of God.

It was unfortunate for the peace of the Church of England, that those who were in authority at this period were disposed to yield too much to the influence of foreigners whose principles were totally alien from those on which the English Reformation was based. That Reformation had been strictly Catholic in its origin and in its official progress, and the repudiation of foreign interference with the Church of England had been one of its main features. But foreign interference now arose from a different quarter, Calvin and his associates endeavouring, with characteristic self-assurance, to bias the mind of England towards Geneva Presbyterianism, rather than Anglican Catholicity. Calvin himself thrust a correspondence upon the Protector Somerset, upon the young King, and upon Archbishop Cranmer². A letter of his still exists in the State Paper Office, which was written to the Duke of Somerset on October 22nd, 1548, and in which he urges the Protector to push the Reformation further than it had hitherto gone. Others to the same purpose may be found in Strype's Memorials of Cranmer [iii. 25]. Peter Martyr and Martin Bucer (neither of whom could understand the English language) were placed in the most important positions at Oxford and Cambridge by Somerset; John à Lasco, a Polish refugee, was quartered upon Cranmer for six months, and afterwards established in a schismatic position in London; and Poullain [Valerandus Pollanus] was, in a similar manner, established at Glastonbury³. These appointments show the manner in which the Church of England was sagaciously leavened with foreign Protestantism by those who wished to reduce it to the same abject level; and they are but a few of the many indications which exist that the Puritanism by which the Church was so imperilled during the succeeding hundred and twenty years arose out of foreign influences thus brought to bear upon the young clergy and the laity of that generation.

These influences soon began to affect the Book of Common Prayer, which had been, with so much forethought, learning, and pious deliberation, prepared by the Bishops and other Divines who composed the Committee to which reference has so often been made. It had been accepted with satisfaction by most of the Clergy and the Laity⁴; and had even been taken into use by many at Easter, although not enjoined to be used until Whitsunday, so desirous were they of adopting the vernacular service. It was, probably, the quiet acceptance of the Prayer Book by the Clergy which raised hopes in the foreign party of moulding it to their own standard of Protestantism.

It is certain that an agitation had been going on, among the latter, from the very time when the Book of 1549 had been first brought into use. A Lasco, Peter Martyr, and Martin Bucer appear to have been continually corresponding about the Prayer Book, and plotting for its alteration, although they knew it only through imperfect translations hastily provided by a Scotchman named Aless, living at Leipsic, and Sir John Cheke. In the Convocation of 1550 a debate on the subject of Revision was started among the Bishops, and the question was sent down also to the Lower House, but it was postponed by the latter until the following Session, and what was done further does not appear; though it is probable that the consideration of the Thirty-nine Articles absorbed the whole attention of

¹ Bp. Jeremy Taylor's Works, vii. 292.

² Heylin's Reformation, i. 227. Eccl. Hist. Soc.

³ The same hospitable but unwise charity towards religious refugees was shown by James I. in the case of Antonio de Dominis, Archbishop of Spalatro, and with most unfortunate results.

⁴ Even Bishop Gardiner's official reply to the Privy Council on the subject was favourable to the Prayer Book. "He had deliberately considered of all the Offices contained in the Common Prayer Book, and all the several branches of it: that though he could not have made it in that manner, had the matter been

referred unto him, yet that he found such things therein as did very well satisfy his conscience; and therefore, that he would not only execute it in his own person, but cause the same to be officiated by all those of his diocese." [Heylin's Reformation, i. 209. Eccl. Hist. Soc.] Somerset, writing to Cardinal Pole, June 4th, 1549, and sending him a Prayer Book, says that there was "a common agreement of all the chief learned men in the Realm" in favour of the new "form and rite of service." [State Papers, Dom. Edw. VI., vol. 7.] Edward VI.'s reply to the Devonshire rebels asserts the same thing.

Convocation for several sessions, and that the proposition for a revised Prayer Book was set aside, as far as the official assembly of the Church was concerned. The young King had now, however, been aroused by the meddlesome letters of Calvin, and perhaps by some of the Puritan courtiers, to entertain a strong personal desire for certain changes in Divine Service; and not being able to prevail on the Bishops to accede to his wishes, he declared to Sir John Cheke (with true Tudor feeling) that he should cause the Prayer Book to be altered on his own authority. It was this determination of Edward, probably, which finally turned the scale in favour of a more constitutional Revision.

No records remain to show us in what manner or by whom this Revision was ultimately made. It has been suggested by Dr. Cardwell [Two Liturgies of Edw. VI., xvii. n.] that the Convocation delegated its authority to a Commission appointed by the King, and that this Commission was the same with that which had set forth the Ordinal of 1550, consisting of "six Prelates, and six other men of this Realm, learned in God's law, by the King's Majesty to be appointed and assigned;" but of which only the name of Bishop Heath of Worcester is recorded. Archdeacon Freeman considers it to be "all but certain that it was the Ordinal Commission which conducted the Revision of 1552," especially because the Ordinal was affixed to the Act of Parliament by which the revised book was legalized¹. There is no certain proof that the Prayer Book of 1552, commonly called the Second Book of Edward VI., ever received the sanction of Convocation; yet it is highly improbable that Cranmer would have allowed it to get into Parliament without it. Edward's second Act of Uniformity, with the revised Prayer Book attached, was passed on April 6th, 1552, with a proviso that the book was to come into use on the Feast of All Saints following. Three editions of the book were printed, but in so unsatisfactory a manner, that on Sept. 27th any further issue of those already printed was forbidden by an Order in Council. At the same time a Royal mandate was sent to Archbishop Cranmer, the purport of which can only be gathered from his reply. This reply is of sufficient interest to be printed at length:—

"After my right humble commendations unto your good Lordships.

"Where I understand by your Lordships' letters that the King's majesty his pleasure is that the Book of Common Service should be diligently perused², and therein the printer's errors to be amended. I shall travaile therein to the uttermost of my power—albeit I had need first to have had the book written which was past by Act of Parliament, and sealed with the great seal, which remaineth in the hands of Mr. Spilman, clerk of the Parliament, who is not in London, nor I cannot learn where he is. Nevertheless, I have gotten the copy which Mr. Spilman delivered to the printers to print by, which I think shall serve well enough. And where I understand further by your Lordships' letters that some be offended with kneeling at the time of the receiving of the sacrament, and would that I (calling to me the Bishop of London, and some other learned men as Mr. Peter Martyr or such like), should with them expend, and weigh the said prescription of kneeling, whether it be fit to remain as a commandment, or to be left out of the book. I shall accomplish the King's Majesty his commandment herein:—albeit I trust that we *with just balance weighed this at the making of the book, and not only we, but a great many Bishops and others of the best learned within this realm appointed for that purpose.* And now the book being read and approved by the whole State of the Realm, in the High Court of Parliament, with the King's majesty his royal assent—that this should be now altered again without Parliament—of what importance this matter is, I refer to your Lordships' wisdom to consider. I know your Lordships' wisdom to be such, that I trust ye will not be moved with these *glorious and unquiet spirits which can like nothing but that is after their own fancy; and cease not to make trouble when things be most quiet and in good order. If such men should be heard—although the book were made every year anew, yet it should not lack faults in their opinion.* 'But,' say they, 'it is not commanded in the Scripture to kneel, and whatsoever is not commanded in the Scripture is against the Scripture, and utterly unlawful and ungodly.' But this saying is the chief foundation of the Anabaptists and of divers other sects. This saying is a subversion of all order as well in religion as in common policy. If this saying be true, take away the whole Book of Service; for what should men travell to set in order in the form of service, if no order can be got but that is already prescribed by Scripture? And because I will not trouble your Lordships with reciting of many Scriptures or proof in this matter; whosoever teacheth any such doctrine (if your Lordships will give me leave) *I will set my foot by his, to be tried by*

¹ See also Heylin's Reformation, i. 228, 229.

² The word "perused" has a technical sense, the force of which is shown by the Act which authorized the Book of 1552, in which it is said that the king had caused the former Book of 1549 to be "perused, explained, and made fully perfect." It thus meant more than the correction of clerical errors.

fire, that his doctrine is untrue; and not only untrue, but also seditious and perilous to be heard of any subjects, as a thing breaking their bridle of obedience and losing from the bond of all Princes' laws.

"My good Lordships, I pray you to consider that there be two prayers which go before the receiving of the Sacrament, and two immediately follow—all which time the people praying and giving thanks do kneel. And what inconvenience there is that it may not be thus ordered, I know not. If the kneeling of the people should be discontinued for the time of the receiving of the sacrament, so that at the receipt thereof they should rise up and stand or sit, and then immediately kneel down again—it should rather import a contemptuous than a reverent receiving of the Sacrament. 'But it is not expressly contained in the Scripture' (say they) 'that Christ ministered the sacrament to his apostles kneeling.' Nor they find it not expressly in Scripture that he ministered it standing or sitting. But if we will follow the plain words of the Scripture we should rather receive it lying down on the ground—as the custom of the world at that time almost everywhere, and as the Tartars and Turks use yet at this day, to eat their meat lying upon the ground. And the words of the Evangelist import the same, which be ἀνακείμεναι and ἀναπίπτω, which signify, properly, to lie down upon the floor or ground, and not to sit upon a form or stool. And the same speech use the Evangelists where they sh(ow) that Christ fed five thousand with five loaves, where it is plainly expressed that they sat down upon the ground and not upon stools.

"I beseech your Lordships take in good part this my long babbling, which I write as of myself only. The Bishop of London is not yet come, and your Lordships required answer with speed, and therefore am I constrained to make some answer to your Lordships afore his coming. And thus I pray God long to preserve your Lordships and to increase the same in all prosperity and godliness.

"At Lambeth, this 7th of October, 1552,

"Your Lordships' to command,

"T. CANTR.¹"

On July 6th, 1553, Edward VI. died, and it does not appear that any of the revised books had been printed after 1552; the "Declaration on kneeling" being inserted on a fly-leaf. It seems very unlikely, therefore, that this second Prayer Book of Edward VI. was ever taken into common use²; and its chief importance is derived from the circumstance that it was made the basis of those further Revisions which resulted in the Prayer Book which has now been used without alteration for two centuries³.

¹ State Papers, Domestic, Edw. VI. xv. 15.

² It was never used at all in Ireland.

³ The following is a condensed account of the two Acts of Uniformity passed in the reign of Edward VI.:—

§ 2 and 3 Edw. VI. c. 1. [A.D. 1549.]

I. For a long time there have been "divers forms of Common Prayer" used in England, that is to say, "the use of Sarum, of York, of Bangor, and of Lincoln; and besides the same, now of late much more divers and sundry forms and fashions have been used in the Cathedral and parish churches of England and Wales, as well concerning the Mattins or Morning Prayer and the Evensong, as also concerning the Holy Communion, commonly called the Mass, with divers and sundry rites and ceremonies concerning the same, and in the administration of other Sacraments of the Church." Some have been pleased with the use of "rites and ceremonies in other form than of late years they have been used," and others greatly offended. The King, Protector, and Council have tried to stay such innovations, but without success; wherefore to the intent that a uniform, quiet, and godly order should be adopted, his Highness has appointed the Archbishop of Canterbury, with other bishops and learned divines, to arrange such an order, "having as well eye and respect to the most sincere and pure Christian religion taught by the Scripture, as to the usages in the Primitive Church." This "rite and fashion of Common and open Prayer and administration of the Sacraments, has been, BY THE AID OF THE HOLY GHOST, WITH ONE UNIFORM AGREEMENT, concluded by them, and is set forth in the Book of Common Prayer." This form of "Mattins, Evensong, celebration of the Lord's Supper, commonly called the Mass, and administration of each of the Sacraments, and all their common and open prayer," is therefore to be said and used from and after the

Feast of Pentecost next ensuing, "and none other or otherwise."

II. Any clergyman refusing to use the Book of Common Prayer, or using any other forms than those set forth therein, shall, on conviction by verdict of a jury, forfeit one of his benefices, and suffer six months' imprisonment for the first offence; for the second offence be imprisoned for twelve months, and forfeit all "his spiritual promotions;" and for the third offence suffer imprisonment for life. Unbeneficed clergy to be imprisoned six months for the first offence, and perpetually for the second.

III. No "interludes, plays, songs, rhymes," or any other open words, are to be allowed to be spoken "in the derogation, depraving, or despising of the same Book, or of any thing therein contained, or any part thereof." No one shall forcibly compel a clergyman to use other forms than those of the Prayer Book, under penalties similar in character to those enacted in the second clause.

IV. Gives power to the Judges to inquire, hear, and determine all offences committed contrary to this Act.

V. Provides that any Archbishop or Bishop may associate himself with the Judge in the trial of such offences as have been committed within his own diocese.

VI. The Prayer Book may be used in Greek, Latin, or Hebrew, by such as understand those languages, with the exception of the Holy Communion.

VII. In "Churches, Chapels, Oratories, or other places," any Psalm or Prayer taken out of the Bible may be used, provided the proper Service has been previously said.

VIII. That the books shall be bought at the charges of the parishioners, and where they have been obtained before Pentecost shall be put in use within three weeks afterwards.

The five following clauses are of a technical kind, and need not be noticed.

The Acts of Uniformity passed in the reign of Edward were legally repealed by I Mary, sess. ii. c. 2, which was passed in October, 1553. By this Act the Services of the Church of England were restored to the condition in which they were in the last year of Henry VIII. A proclamation was also issued, enjoining that no person should use "any book or books concerning the common service and administration set forth in English to be used in the churches of this realm, in the time of King Edward the VIth, commonly called the Communion Book, or Book of Common Service and Ordering of Ministers, otherwise called the Book set forth by the authority of Parliament, for Common Prayer and Administration of the Sacraments; but shall, within fifteen days bring or deliver the said books to the Ordinary, where such books remain, at the said Ordinary's will and disposition to be burnt." This Act and Proclamation were preceded, apparently, by an Act of Convocation of the same tenour; for the Upper House had been requested by the Lower (both being doubtless "packed" assemblies at the time) to suppress the "schismatical book called the Communion Book, and the Book of Ordering Ecclesiastical Ministers." Thus the work which had been done with so much care and deliberation was, for a time, set aside; Divine Service was again said in Latin, and the customs of it reverted, to a great extent, to their mediæval form. As, however, the monasteries were not revived, the devotional system of Queen Mary's reign must, in reality, have been considerably influenced in the direction of reformation. We have already seen that "the last year of the reign of Henry VIII." (which was the standard professedly adopted) was a period when much progress had been made towards establishing the devotional system afterwards embodied in the Book of Common Prayer; and it seems likely that the services of the Church in the reign of Queen Mary were a modified form of, rather than an actual return to, the mediæval system which existed before the sixteenth century.

Queen Elizabeth succeeded to the throne on November 17th, 1558, and for a month permitted no change to be made in the customs of Divine Service.

On December 27th of that year, a Proclamation was issued condemning unfruitful disputes in matters of religion, and enjoining all men "not to give audience to any manner of doctrine or preaching other than to the Gospels and Epistles, commonly called the Gospel and Epistle of the day, and to the ten commandments, in the vulgar tongue, without exposition or addition of any manner, sense, or meaning to be applied or added; or to use any other manner of publick prayer, rite, or ceremony in the Church, but that which is already used and by law received; or the common Litany used at this present in her Majesty's own chapel¹; and the Lord's Prayer, and the Creed, in English, until consultation may be had by Parliament, by her Majesty and her three estates of this realm², for the better conciliation and accord of such causes as at this present are moved in matters and ceremonies of religion."

The first Act of Parliament in the reign of Queen Elizabeth restored to the Crown the supremacy over persons and causes ecclesiastical, which had been taken away from it in the previous reign. But this does not seem to have been considered sufficient authority for dealing with the subject of Divine Service; nor does it seem to have been possible, at first, to place it in the hands of Convocation. An irregular kind of Committee was therefore appointed at the suggestion of Sir Thomas Smith, the Queen's Secretary, who were to meet at his house in Cannon Row, Westminster, and who were "to draw in other men of learning and gravity, and apt men for that purpose and credit, to have their assents." This Committee consisted of the following³ persons:—

§ 5 and 6 Edw. VI. c. 1. [A.D. 1552.]

I. The Book of Common Prayer, "a very godly order, agreeable to the Word of God and the primitive Church, very comfortable to all Christian people desiring to live in Christian conversation, and most profitable to the state of this realm," having been set forth by authority of Parliament, yet a great number of persons "following their own sensuality, and living either without knowledge or due fear of God," neglect to come to church on Sundays and Holy-days.

II. For reformation thereof, it is enacted that every person shall duly attend church, unless they have some reasonable hindrance. The two following clauses give authority to punish those who disobey the Act.

V. Doubts about the manner of using the Prayer Book having arisen, "rather by the curiosity of the minister and mistakers,

than of any other worthy cause," the said book has, by command of the King, and with the authority of Parliament, been "faithfully and godly perused, explained, and made fully perfect," and a form for the consecration of bishops, and ordination of priests and deacons, has been annexed to it. The revised book is to be in force under the provisions of the former Act; and shall be put in use by all persons after the Feast of All Saints, under penalties such as those previously enacted: every Curate reading this Act on one Sunday in every quarter of a year; and enforcing the duty of Common Prayer in an exhortation to his people.

Both Acts were repealed by I Mary, sess. ii. c. 2, but by the Act of Eliz. this repeal became void, so far as concerned the Book of 1552. That of 1549 still remains under the repeal of Mary's Act.

¹ The English Litany of Henry VIII. See State Papers, Dom. Eliz. i. 68.

² That is, Lords, Commons, and Clergy. See note at p. 64.

Matthew Parker, subsequently Abp. of Canterbury.
 Edmund Grindal, „ Bp. of London, Abp. of York, and Abp. of Canterbury.
 James Pilkington, „ Bp. of Durham.
 Richard Cox, restored, Bp. of Ely.
 William May, appointed Abp. of York, but died before consecration.
 William Bill, subsequently Dean of Westminster.
 Sir Thomas Smith, „ Dean of Carlisle.
 David Whitehead, „ [Declined the Archbishopric of Canterbury.]
 Edwin Sandys, „ Bp. of Worcester, and Abp. of York.
 Edmund Guest, „ Bp. of Rochester, and of Salisbury.

The last two were summoned to attend upon the Committee after its first appointment. It has been supposed, from a vindication of the changes made which was sent by him to Cecil¹, that Guest was the person chiefly concerned in the revision, and that he acted for Parker, who was absent through illness. Cox and May were on the Committee of 1542-1549.

While this Committee was engaged on its labours, an attempt was made to reconcile the extreme Romanist party by a Conference of Divines held before the Privy Council and others in Westminster Abbey; but the attempt failed through the impracticable temper of the leading men on the Romanist side: and thus the way was made clear for a new Act of Uniformity on the basis of those passed in Edward's reign.

The Queen and Cecil both appear to have desired that the original Prayer Book, that of 1549, should be adopted as far as possible; but the second Book, that of 1552, was taken by the Committee of Divines, and with a few alterations of some importance, submitted to the Queen to be set before Parliament. The most important of these alterations were the following:—

[1] A Table of Proper Lessons for Sundays was prefixed.

[2] The "accustomed place" or Chancel, instead of "in such place as the people may best hear," was appointed for the celebration of Divine Service.

[3] The "Ornaments" of the Church and the Ministers which had been in use under the first Book of Edward, but had been reduced to a *minimum* by the second, were directed again to be taken into use.

[4] The Litany clause, "From the tyranny of the Bishop of Rome, and all his detestable enormities," was now omitted.

[5] The present form for administering the consecrated Elements to the communicants was substituted for that ordered by the Book of 1552, which was the latter half only of that now used. As the first half of the words is the form that was used in the Book of 1549, the new form was thus a combination of the two.

[6] The declaration respecting kneeling, which had been inserted on a fly-leaf at the end of the Communion Service in the Book of 1552, was now omitted altogether.

Thus altered, the Book was laid before Parliament, which (without any discussion) annexed it to the Act of Uniformity. [1 Eliz. cap. 2.] This Act was passed on April 28th, 1559, and it enacted that the revised Prayer Book should be taken into use on St. John the Baptist's day following. It was used, however, in the Queen's chapel on Sunday, May 12th, and at St. Paul's Cathedral on Wednesday, May 15th. After the appointed day had passed, a Commission was issued [July 19, 1559] to Parker, Grindal, and others for carrying into execution the Acts for Uniformity of Common Prayer, and for restoring to the Crown its jurisdiction in Ecclesiastical matters². A Royal Visitation was also held in the Province of York, under a Commission dated July 25th³. It then appeared that the Prayer Book was so generally accepted by the Clergy, that out of 9400 only 189 refused to adopt it; this number including those Bishops and others of the most extreme Romanist party, who had been appointed in Queen Mary's reign on account of what in modern times would be called their Ultramontane prejudices.

It is worth notice, however, that the Book of Common Prayer as thus revised in 1559 was quietly accepted by the great body of Romanist laity; and also that the Pope himself saw so little to object to in it that he offered to give the book his full sanction if his authority were recognized by the Queen and

¹ Cardw. Conf. 48. Strype's Ann. i. 120, ii. 459.

² State Papers, Dom. Eliz. v. 18.

³ Ibid. iv. 62.

kingdom. "As well those restrained," said Sir Edward Coke, "as generally all the papists in this kingdom, not any of them did refuse to come to our church, and yield their formal obedience to the laws established. And thus they all continued, not any one refusing to come to our churches, during the first ten years of her Majesty's government. And in the beginning of the eleventh year of her reign, Cornwallis, Bedingfield, and Silyarde, were the first recusants; they absolutely refusing to come to our churches. And until they in that sort began, the name of recusant was never heard of amongst us." In the same Charge, Coke also states as follows:—That the Pope [Pius IV.] "before the time of his excommunication against Queen *Elizabeth* denounced, sent his letter unto her Majesty, in which he did allow the *Bible*, and Book of *Divine Service*, as it is now used among us, to be authentick, and not repugnant to truth. But that therein was contained enough necessary to salvation, though there was not in it so much as might conveniently be, and that he would also allow it unto us, without changing any part: so as her Majesty would acknowledge to receive it from the *Pope*, and by his allowance; which her Majesty denying to do, she was then presently by the same Pope excommunicated. And this is the truth concerning Pope Pius Quartus as I have faith to God and men. I have oftentimes heard avowed by the late *Queen* her own words; and I have conferred with some *Lords* that were of greatest reckoning in the *State*, who had seen and read the Letter, which the Pope sent to that effect; as have been by me specified. And this upon my credit, as I am an honest man, is most true¹." It may have been with the object of making the Pope acquainted with the real character of the Prayer Book that it was translated into Latin in the same year; and it is, possibly, to the work of translation that a document in the State Paper Office refers [Eliz. vii. 46] which, on November 30th, 1559, mentions the progress made by the Convocation in the Book of Common Prayer². The Latin Version (differing in no small degree from the English) was set forth on April 6th, 1560, under the authority of the Queen's Letters Patent.

The only other change that was made in the Prayer Book during the reign of Elizabeth was in the Calendar. On January 22nd, 1561, the Queen issued a Commission to the Archbishop of Canterbury, the Bishop of London, Dr. Bill, and Walter Haddon, directing them "to peruse the order of the said Lessons throughout the whole year, and to cause some new calendars to be imprinted, whereby such chapters or parcels of less edification may be removed, and other more profitable may supply their rooms³." This commission was issued by the authority given in the 13th clause of Elizabeth's Act of Uniformity, which is cited in its opening paragraph; and in the end of it there is a significant direction, "that the alteration of any thing hereby ensuing be quietly done, without show of any innovation in the Church." In the Calendar revised by these Commissioners the names of most of those Saints were inserted which are to be found in that of our present Prayer Book.

But although no further changes were made in the authorized devotional system of the Church during the remainder of the century, continual assaults were being made upon it by the Puritan party, extreme laxity was tolerated, and even sanctioned, by some of the Bishops (as, for example, at Northampton, by Bishop Scambler of Peterborough), and the people were gradually being weaned from their love for a Catholic ritual: while, in the meantime, a great number of the new generation were being trained, by continual controversy and by enforced habit, into a belief that preaching, either in the pulpit or under the disguise of extemporaneous prayer, was the one end and aim of Divine Service⁴. In 1592 the Puritans had grown so rancorous that they presented a petition to the Privy Council in which the Church of England is plainly said to be derived from Antichrist; the press swarmed with scurrilous and untruthful pamphlets against the Church system; and the more sober strength of this opposition may be measured very fairly by the statements and arguments of Hooker in his noble work, the "Ecclesiastical Polity."

On the accession of James I., which occurred on May 7th, 1603, the hopes of those who wished

¹ The Lord Coke, his Speech and Charge, London, 1607. See also Camden, Ann. Eliz., p. 59, ed. 1615. Twysden's Historical Vindication of the Church of England, p. 175. Validity of the Orders of the Church of England, by Humphrey Prideaux, D.D., 1688. Bramhall's Works, ii. 85, ed. 1845. Bp. Babington's Notes on the Pentateuch; on Numbers vii. Courayer's Defence of the Dissertation on the Validity of English Ordinations, ii. 360. 378. Harrington's Pius IV. and the Book of Common Prayer, 1856.

² Sir John Mason, however, writes to Cecil, on Aug. 11th, 1559,

that the Book of Common Service in Latin is ready to print: and also the little book of Private Prayers for children and servants. State Papers, Dom. Eliz. vi. 11.

³ Parker Correspondence, p. 132. State Papers, xvi. 7.

⁴ These foreign fashions and principles were pertinaciously maintained by those who had fled the country in Queen Mary's days, and returned with what Parker called "Germanical natures" in Queen Elizabeth's. [Strype's Parker, i. 156.] See also Cardw. Conf. 117—120, for a strong illustration of this in Convocation.

to get rid of the Prayer Book were strengthened by the knowledge that the King had been brought up by Presbyterians. A petition was presented to him, called the "Millenary Petition," from the number of signatures attached to it, in which it was represented that "more than a thousand" of his Majesty's subjects were "groaning as under a common burden of human rites and ceremonies," from which they prayed to be relieved by a reduction of the Prayer Book system to their own standard. The result of this petition was the "Hampton Court Conference," an assembly of Clergy and Non-conformists, summoned by the King to meet in his presence at the Palace of Hampton Court, and discuss the grievances complained of. This Conference met on the 14th, 16th, and 18th of January, 1603-4, in the presence of the King and the Privy Council; but the former was so disgusted with the unreasonableness of the Puritan opponents of the Prayer Book, that he broke up the meeting abruptly on the third day, without committing the Church to any concessions in the direction they required. Under the same clause of the Act of Uniformity by which Queen Elizabeth had directed a revision of the Calendar, the King did, however, cause a few changes to be made in the Prayer Book¹.

[1] The words "or remission of sins" were added to the title of the Absolution.

[2] The "Prayer for the Royal Family" was placed at the end of the Litany; and also some Occasional Thanksgivings.

[3] Two slight verbal changes were made at the beginning of the Gospels for the Second Sunday after Easter and the Twentieth Sunday after Trinity.

[4] An alteration was made in one of the Rubrics for Private Baptism. [See the Office.]

[5] The title of the Confirmation Service was enlarged.

[6] The latter part of the Catechism, respecting the Sacraments, was added.

[7] Some slight changes were made in the Calendar.

In the following year a petition was presented to the King from ministers in the Diocese of Lincoln, in which fifty "gross corruptions" were enumerated in the Prayer Book: and they demanded its total abolition as the only means by which the land could be rid of the idolatry and superstition which it enjoined. Such was the spirit of the times upon which the Church of England was now entering, and which culminated, after a struggle of forty years more, in the suppression of the Prayer Book.

An "ordinance" was passed by the Parliament on January 3rd, 1645, which repealed the Acts of Uniformity, and enacted that the Book of Common Prayer should not thenceforth be used in any Church, Chapel, or place of worship in England or Wales.

On August 23rd, 1645, another ordinance forbade the use of it in private, required all copies of the Book be given up, and imposed heavy penalties upon those who dared to disobey these singularly tyrannical injunctions. For fifteen years the prayers of the Church of England could only be said in extreme privacy, and even then with danger of persecution to those who used them².

§ *The Revision of 1661.*

When the new form of government, established by Cromwell, had collapsed after his death, the restoration of the ancient constitution of the country involved the restoration of its ancient Church, and consequently of its ancient system of devotion as represented by the Book of Common Prayer. Notwithstanding the highly penal law which had been passed against its use, there had been many bold and faithful men who had not feared to "obey God rather than men." Bishops Bull and Sanderson had been notable instances of this steadfastness, and they did not by any means stand alone³. As the time drew

¹ See the official document in Cardw. Conf. pp. 217—225.

² In the State Papers, Kennett's Register, and Walker's Sufferings of the Clergy, there are many cases recorded of heavy fines levied on those who were discovered using the Prayer Book.

³ "The iniquity of the times would not bear the constant and regular use of the Liturgy; to supply therefore that misfortune, Mr. Bull formed all the devotions he offered up in public, while he continued minister of this place, out of the Book of Common Prayer, which did not fail to supply him with fit matter and proper words upon all those occasions that required him to apply to the throne of grace with the wants of his people. He had the example of one of the brightest lights of that age, the judicious Dr. Sanderson, to justify him in this practice; and his

manner of performing the public service was with so much fervour and ardency of affection, and with so powerful an emphasis in every part, that they who were most prejudiced against the Liturgy, did not scruple to commend Mr. Bull as a person that prayed by the Spirit, though at the same time they railed at the Common Prayer as a beggarly element, and as a carnal performance.

"A particular instance of this happened to him while he was minister of St. George's, which, because it showeth how valuable the Liturgy is in itself, and what unreasonable prejudices are sometimes taken up against it, the reader will not, I believe, think it unworthy to be related. He was sent for to baptize the child of a Dissenter in his parish, upon which occasion he made

near for the return of Charles II. to the throne of his fathers, Prayer Books were brought from their hiding-places, printers began to prepare a fresh supply¹, and its offices began to be openly used, as in the case of the good and great Dr. Hammond, who was interred with the proper Burial Service on April 26th, 1660. Before the end of 1660, the demand for Prayer Books had been so great, notwithstanding the number of old ones which had been preserved, that three several editions in folio, quarto, and a smaller size are known to have been printed.

Charles the Second landed in England on May 26th, 1660, the Holy Communion having been celebrated on board the "Naseby" at a very early hour in the morning; probably by Cosin, the King's Chaplain, whose influence was afterwards so great in the revision of the Prayer Book. As soon as the Court was settled at Whitehall, Divine Service was restored in the Chapel Royal. On July 8th, Evelyn records in his Diary [ii. 152], that "from henceforth was the Liturgy publicly used in our Churches." Patrick is known to have used it in his church on July 2nd; and Cosin, who reassumed his position as Dean of Peterborough at the end of that month, immediately began to use it in his Cathedral. From Oxford, Lamplugh (subsequently Archbishop of York) writes on August 23rd, 1660, that the Common Prayer was then used every where but in three colleges², showing how general had been its restoration in the University Chapels, and perhaps also in the City Churches. By October, 1661, Dean Barwick had restored the Choral Service first at Durham, and then at St. Paul's. The feeling of the people is indicated by several petitions which were sent to the King, praying that their ministers might be compelled to use the Prayer Book in Divine Service, the Mayor and Jurats of Faversham (for example) complaining that their Vicar, by refusing to give them the Common Prayer, is³ "thus denying them their mother's milk⁴." The non-conforming ministers at first allowed that they could use the greatest part of the Prayer Book; yet when requested by the King to do so, omitting such portions as they could not use, they declined⁴; but on the part of the laity in general the desire for its restoration seems to have been much greater than could be supposed, considering how many had never (as adults) even heard a word of it used in Church; and probably had never even seen a Prayer Book.

Before the King had left the Hague, a deputation of Presbyterian ministers, including Reynolds, Calamy, Case, and Manton, had gone over to him to use their influence in persuading him that the use of the Prayer Book having been so long discontinued, it would be most agreeable to the English people if it were not restored; and especially to dissuade him from using it and the surplice, in the Chapel Royal. No doubt this was a very daring misrepresentation of the state of the public mind on the subject; but the King appears to have been aware that it was so, for he declined, with much warmth, to agree to the impertinent and unconstitutional request, telling them in the end of his reply, that "though he was bound for the present to tolerate much disorder and indecency in the exercise of God's worship, he would never in the least degree, by his own practice, discountenance the good old order of the Church in which he had been bred⁵." As we have already seen, the Prayer Book was restored to use in the Chapel Royal immediately after the King's return.

On July 6th, five weeks afterwards, there was a debate in Parliament respecting the settlement of religion. Some suggested that the restoration of the "old religion" was the only settlement required; but in the end it was agreed to pray the King that he would call an assembly of divines for the purpose

use of the office of Baptism, as prescribed by the Church of England, which he had got entirely by heart; and he went through it with so much readiness and freedom, and yet with so much gravity and devotion, and gave that life and spirit to all that he delivered, that the whole audience was extremely affected with his performance; and notwithstanding that he used the sign of the cross, yet they were so ignorant of the offices of the Church that they did not thereby discover that it was the Common Prayer. But after that he had concluded that holy action, the father of the child returned him a great many thanks, intimating at the same time with how much greater edification they prayed, who entirely depended upon the Spirit of God for His assistance in their extempore effusions, than those did who tied themselves up to premeditated forms; and that if he had not made the sign of the cross, that badge of Popery, as he called it, nobody could have formed the least objection against his excellent prayers. Upon which Mr. Bull, hoping to recover him from his ill-grounded prejudices, showed him the office of Baptism in the Liturgy, wherein

was contained every prayer which he had offered up to God on that occasion; which, with farther arguments that he then urged, so effectually wrought upon the good man and his whole family, that they always after that time frequented the parish church, and never more absented themselves from Mr. Bull's communion." —Nelson's Life of Bull, p. 31.

¹ John Williams and Francis Eglesfield printed an edition against the King's return, and what copies remained in their warehouse were seized by agents of Bill the King's printer on Nov. 7th, 1660. There is extant also a royal mandate to Bill, dated July 25, 1661, commanding him to restore to R. Royston, of Oxford, a quantity of Prayer Books which he had seized by mistake, supposing them to be falsely printed. State Papers, Domestic, Charles II., vol. xxxix. 87; xlvii. 67.

² State Papers, *ibid.* xi. 27.

³ *Ibid.* xxxii. 97. 109; l. 22.

⁴ Kennett's Register, p. 629.

⁵ Clarendon, *History of the Great Rebellion*, iii. 990.

of considering the subject. The King, however, issued a "Declaration" on October 25th, in which he refers to his letter from Breda promising toleration to all opinions, and to the visit of the Presbyterian preachers; and complains of the intolerant spirit which is shown towards himself by the Presbyterians in wishing to deprive him of the services in the Chapel Royal, and in much misrepresenting his words, acts, and motives. He states, that it had been his intention to call a Synod at once to consider the affairs of the Church, but that personal feeling is so strong as to make such a step unwise for the present. Throughout this Declaration the King assumes that the Church is restored in its integrity; but promises that he will call an assembly of "learned Divines, of both persuasions," to review the "Liturgy of the Church of England, contained in the Book of Common Prayer, and by law established;" again exhorting those who cannot conscientiously use the whole of it, to use such portions as they do not object to¹.

It was in fulfilment of this promise that a Royal Commission was addressed on March 25th, 1661, to the following Divines, who constituted what is known as the "Savoy Conference," from its place of meeting:—

On the Church side.

Accepted Frewen, Archbishop of York.
 Gilbert Sheldon, Bishop of London, afterwards
 Archbishop of Canterbury.
 John Cosin, Bishop of Durham.
 John Warner, Bishop of Rochester.
 Henry King, Bishop of Chichester.
 Humphry Henchman, Bishop of Salisbury, after-
 wards of London.
 George Morley, Bishop of Worcester, afterwards of
 Winchester.
 Robert Sanderson, Bishop of Lincoln.
 Benjamin Laney, Bishop of Peterborough, after-
 wards of Lincoln and Ely.
 Brian Walton, Bishop of Chester.
 Richard Sterne, Bishop of Carlisle, afterwards
 Archbishop of York.
 John Gauden, Bishop of Exeter, afterwards of
 Worcester.

On the Presbyterian side.

Edward Reynolds, Bishop of Norwich.
 Anthony Tuckney, D.D., Master of St. John's
 Cambridge.
 John Conant, D.D., Reg. Prof. Div., Oxford.
 William Spurstow, D.D.
 John Wallis, D.D., Sav. Prof. Geom., Oxford.
 Thomas Manton, D.D. [offered Deanery of Ro-
 chester.]
 Edmund Calamy [offered Bishopric of Lichfield].
 Richard Baxter [offered Bishopric of Hereford].
 Arthur Jackson.
 Thomas Case.
 Samuel Clarke.
 Matthew Newcomen.

Coadjutors.

John Earle, Dean of Westminster, afterwards Bishop of Worcester and Salisbury.	Thomas Horton, D.D.
Peter Heylin, D.D., Subdean of Westminster.	Thomas Jacomb, D.D.
John Hacket, D.D., afterwards Bishop of Lichfield.	William Bate.
John Barwick, D.D., afterwards Dean of St. Paul's.	John Rawlinson.
Peter Gunning, D.D., afterwards Bishop of Chi- chester and Ely.	William Cooper.
John Pearson, D.D., afterwards Bishop of Chester.	John Lightfoot, D.D.
Thomas Pierce, D.D.	John Collings, D.D.
Anthony Sparrow, D.D., afterwards Bishop of Exeter and Norwich.	Benjamin Woodbridge, D.D.
Herbert Thorndike, D.D.	William Drake.

As this Conference was the last official attempt to reconcile what was afterwards called the "Low Church party" and Dissenters to the cordial use of the Catholic Offices of the Church, it will be desirable to give a short account of its proceedings. The Letters Patent authorized the Commissioners "to advise upon and review the said Book of Common Prayer, comparing the same with the most ancient liturgies, which have been used in the Church in the primitive and purest times; and to that end to

¹ Cardwell's Conferences, p. 286.

² "And was after by Synod commissioned to review the Com-
mon Prayer Book." Fothergill's MS., York Minster Lib.

assemble and meet together from time to time, and at such times within the space of four calendar months now next ensuing, in the Master's lodgings in the Savoy in the Strand, in the county of Middlesex, or in such other place or places as to you shall be thought fit and convenient; to take into your serious and grave considerations the several directions, rules, and forms of prayer, and things in the said Book of Common Prayer contained, and to advise and consult upon and about the same, and the several objections and exceptions which shall now be raised against the same. And if occasion be, to make such reasonable and necessary alterations, corrections, and amendments therein, as by and between you and the said Archbishop, Bishops, Doctors, and persons hereby required and authorized to meet and advise as aforesaid, shall be agreed upon to be needful or expedient for the giving satisfaction unto tender consciences, and the restoring and continuance of peace and unity in the Churches under our protection and government; but avoiding, as much as may be, all unnecessary alterations of the forms and liturgy wherewith the people are already acquainted, and have so long received in the Church of England¹."

This Commission met at the Savoy in the Strand on April 15th, and its sittings ended on July 24th, 1661: the Session of Parliament and Convocation commencing on May 8th of the same year. The "several objections and exceptions" raised against the Prayer Book were presented to the Bishops in writing. * These are all on record in two or three contemporary reports of the Conference, of which one is referred to in the foot-note, and they are printed at length in Cardwell's *Conferences on the Book of Common Prayer*. Many of these "exceptions" are of a frivolous kind, and the remarks which accompanied them were singularly bitter and uncharitable, as well as diffuse and unbusiness-like. It seems almost incredible that grave Divines should make a great point of "The Epistle is written in" being an untrue statement of the case when a portion of a prophecy was read and technically called an "Epistle;" or that they should still look upon it as a serious grievance when the alteration conceded went no further than "For the Epistle:" or, again, that they should spend their time in writing a long complaint about the possibility of their taking cold by saying the Burial Service at the grave. Yet sheets after sheets of their papers were filled with objections of this kind, and with long bitter criticisms of the principles of the Prayer Book. The Bishops replied to them in the tone in which Sanderson's Preface to the Prayer Book is written, but they seem to have keenly felt what Sanderson himself expressed—mild and gentle as he was—when he long afterwards said of his chief opponent at the Savoy, "that he had never met with a man of more pertinacious confidence, and less abilities, in all his conversation²." Perhaps too they were reminded of Lord Bacon's saying respecting his friends, the Nonconformists of an earlier day, that they lacked two principal things, the one learning, and the other love.

The Conference was limited by the Letters Patent to four months' duration, but when that time had drawn to an end little had been done towards a reconciliation of the objectors to the use of the Prayer Book. Baxter had composed a substitute for it, but even his friends would not accept it as such, and probably Baxter's Prayer Book never won its way into any congregation of Dissenters in his lifetime or afterwards. In Queen Elizabeth's time Lord Burleigh had challenged the Dissenters to bring him a Prayer Book made to fit in with their own principles; but when this had been done by one party of Dissenters, another party of them offered six hundred objections to it, which were more than they offered to the old Prayer Book. The same spirit appears to have been shown at the Savoy Conference; and the principle of unity was so entirely confined to unity in opposition, that it was impossible for any solid reconciliation of the Dissenters to the Church to have been made by any concessions that could have been offered. After all the "exceptions" had been considered and replied to by the Bishops' side (replies again replied to by the untiring controversial pens of the opposite party), the result of the Commission was exhibited in the following list of changes to which the Bishops were willing to assent;—

The Concessions offered by the Bishops at the Savoy Conference.

- § 1. We are willing that all the epistles and gospels be used according to the last translation.
 § 2. That when any thing is read for an epistle which is not in the epistles, the superscription shall be "For the epistle."
 § 3. That the Psalms be collated with the former translation, mentioned in rubr., and printed according to it.

¹ Cardw. Conf. 257—368. "Grand Debate between the most Reverend the Bishops and the Presbyterian Divines. . . . The most perfect copy." 1661.

² Kennett's Register, p. 551. This can hardly refer to Baxter, who was a man of some learning; but no doubt his excessive vanity and moroseness were a chief cause of the failure.

§ 4. That the words "this day," both in the collects and prefaces, be used only upon the day itself; and for the following days it be said, "as about this time."

§ 5. That a longer time be required for signification of the names of the communicants; and the words of the rubric be changed into these, "at least some time the day before."

§ 6. That the power of keeping scandalous sinners from the communion may be expressed in the rubr. according to the xxvith and xxviith canons; so the minister be obliged to give an account of the same immediately after to the ordinary.

§ 7. That the whole preface be prefixed to the commandments.

§ 8. That the second exhortation be read some Sunday or Holy Day before the celebration of the communion, at the discretion of the minister.

§ 9. That the general confession at the communion be pronounced by one of the ministers, the people saying after him, all kneeling humbly upon their knees.

§ 10. That the manner of consecrating the elements be made more explicit and express, and to that purpose these words be put into the rubr., "Then shall he put his hand upon the bread and break it," "then shall he put his hand unto the cup."

§ 11. That if the font be so placed as the congregation cannot hear, it may be referred to the ordinary to place it more conveniently.

§ 12. That these words, "yes, they do perform these," &c., may be altered thus: "Because they promise them both by their sureties," &c.

§ 13. That the words of the last rubr. before the Catechism may be thus altered, "that children being baptized have all things necessary for their salvation, and dying before they commit any actual sins, be undoubtedly saved, though they be not confirmed."

§ 14. That to the rubr. after confirmation these words may be added, "or be ready and desirous to be confirmed."

§ 15. That these words, "with my body I thee worship," may be altered thus, "with my body I thee honour."

§ 16. That these words, "till death us depart," be thus altered, "till death us do part."

§ 17. That the words "sure and certain" may be left out.

The Conference being ended, and with so little practical result, the work of Revision was committed to the Convocations of the two Provinces of Canterbury and York. On June 10th, 1660, a Licence had been issued to the Archbishop of Canterbury [Juxon], empowering the Convocation of his Province to "debate and agree upon such points as were committed to their charge¹." Another was issued to the Archbishop of York [Frewen], of a similar tenour, on July 10th [or 23rd]. But little was likely to be done while the Savoy Conference was sitting, beyond preparation for future action. A fresh Licence was issued on October 10th, by which the Convocation of Canterbury was definitely directed to review the Book of Common Prayer and the Ordinal², under the authority of the Commission sent to them on the 10th of June³: and on November 22nd a similar letter was sent to the Archbishop of York. This letter enjoined the Convocations to review the Prayer Book, and then to present it to "us for our further consideration, allowance, or confirmation⁴."

It is probable that much consideration had been given to the subject during the five months that elapsed between the issue of the first Licence and that of the second, as a Form for the 29th of May had been agreed upon, and also the Office for Adult Baptism. When, however, the Convocation of Canterbury met on November 21st, 1661, "the King's letters were read," and the revision of the Prayer Book was immediately entered upon with vigour and decision⁵. The Upper House appointed a Committee, consisting of the following:—

Matthew Wren,	Bishop of Ely.
Robert Skinner,	„ „ Oxford.
John Warner,	„ „ Rochester.
Humphry Henchman,	„ „ Salisbury.
George Morley,	„ „ Worcester.

¹ State Papers, Dom. Charles II. xliii. *October* 10.

² Kennett's Register, p. 503.

³ State Papers, Dom. Charles II. xliii.

⁴ Kennett's Register, p. 564.

⁵ The Bishops returned to their seats in the House of Lords on Nov. 20th, and from that time the junior Bishop said prayers daily as formerly. The Presbyterian minister had been "excused from attendance" on the House of Commons some time before.

Robert Sanderson, Bishop of Lincoln.
 William Nicholson, „ „ Gloucester.
 John Cosin, „ „ Durham.

The last-named had been invited (with the Archbishop of York, and the Bishops of Carlisle and Chester) to be present and assist at the previous session of the Southern Convocation; and was now appointed on the Committee as the most learned ritualist among the Bishops. Wren, Warner, and Skinner had been Bishops in the Convocation of 1640¹.

It was necessary that the co-operation of the York Lower House of Convocation should be secured: the Archbishop and three Bishops of that Province therefore wrote to them, saying that the time was very short for the work in hand, and that it would much facilitate its progress if some Clergy were appointed to act in the Southern Convocation as Proxies for the Northern. Eight such proxies were appointed, three of whom were members of the lower house of Canterbury Province, and five of the lower house of York².

The Committee of Bishops met at Ely House; and Sancroft, at this time Rector of Houghton-le-Spring, Prebendary of Durham, and Chaplain to Cosin, appears to have acted as their Secretary. Bishop Cosin had prepared a folio Prayer Book of 1619, in which he had written down in the margin such alterations as he considered desirable: and this volume, which is preserved in the Cosin Library, Durham [D. III. 5], has been thoroughly examined for the present work, all the alterations so made being either referred to or printed in the Notes³. This volume was evidently used as the basis of their work by the Bishops, although (as will be seen) they did not adopt all the changes proposed by Cosin, and introduced others which are not found in his Prayer Book. They were thus enabled to proceed rapidly with the work of revision, and on November 23rd sent a portion of their labours down to the Lower House, which returned it on the 27th. The whole Prayer Book was completed by December 20th, and a form of Subscription was then agreed upon, of which a copy in Bishop Cosin's handwriting is inserted in his Durham Book, and which is also to be found, with all the names attached, in Kennett's Register, pp. 584, 585. The Revised volume, thus prepared, was a MS. of five hundred and forty-four pages, and appears to have been the same that was ultimately attached to the Act of Uniformity. It is said to have been preserved in the Parliament Office as recently as 1825, and is referred to as existing there in the Record Commissioners' edition of the Statutes, vol. v. p. 365; but it has since disappeared.

There was a delay of some weeks before the Prayer Book thus revised received the approval of the King in Council. The Act of Uniformity was under the consideration of the House of Lords, and on February 12th, 1661-2, the Earl of Dorset expressed the disappointment of the House at not receiving the revised Prayer Book; on which the Bishop of London promised that it should shortly be brought in. A Privy Council was then summoned, at which four Bishops were ordered to be present. This met on February 24th, 1661-2, the Bishops of London, Durham, Salisbury, Worcester, and Chester being present: "at which time the Book of Common Prayer, with the Amendments and Additions, as it was prepared by the Lords Bishops, was read and approved, and ordered to be transmitted to the House of Peers, with this following recommendation, signed by His Majesty:"—the recommendation being that the Prayer Book as altered be that appointed to be used by the intended Act of Uniformity⁴. On the next day it was sent to the House of Lords, with the Great Seal attached⁵; and on March 17th was declared (without any review of its contents) to be the Book referred to in the Act of Uniformity then passing through the House. On March 18th the thanks of the House were conveyed to Convocation for their care in revising the Book, and on April 10th it was sent down to the House of Commons.

On the 16th of April the question was put in the House of Commons whether there should be any debate upon the amendments inserted in the Prayer Book by Convocation, and it was decided in the

¹ Archbishop Juxon, Bishops Duppa, Piers, and Roberts, had also been Bishops in 1640. Four other Bishops in the Upper House of 1661, Sheldon, Floyd, Griffith, and Ironside, had been in the Lower House in 1640, and so had about twenty members of the Lower House of 1661.

² Kennett's Register, pp. 563-565.

³ A fair copy of this volume, written by Sancroft in a Prayer Book of 1634, is preserved in the Bodleian Library [Arch. Bodl. D. 28], and has been collated with the original for the present work. Cosin had also written three sets of Notes on the Prayer

Book; and had prepared a fourth, suggesting amendments which he considered to be necessary several years before. These are collected in the fifth volume of his Works, published in the Library of Anglo-Catholic Theology. Some MS. Notes on the Prayer Book, Harl. MS. 7311, are also said to be his.

⁴ Kennett's Register, pp. 632, 633. State Papers, li. 5.

⁵ When the Bill for Uniformity had been sent up from the House of Commons, a Prayer Book (probably that of Elizabeth) had been attached to it, but this was set aside for that of the Convocation. Kennett's Register, p. 642.

negative. A resolution was, however, afterwards passed, that they "might have been debated by the order of the House." Thus, although the Act of Uniformity was much discussed in the House of Commons, the Book of Common Prayer was accepted by them, as well as by the Lords, exactly as it had passed out of the hands of the Bishops; and nothing was ever said about their right to consider the work of the Convocation until it had been decided that it was to pass unaltered through the secular part of the Legislature. This determination was also strongly illustrated by two circumstances that occurred while the Prayer Book was before the two Houses. (1) A strong desire was expressed in the House of Commons that a proviso should be introduced into the Act of Uniformity, enjoining reverent gestures during the time of Divine Service. This proviso was twice read, "but the matter being held proper for the Convocation," it was ordered that those members who managed the Conference with the Lords should intimate the desire of the House, "that it be recommended to the Convocation to take order for reverent and uniform gestures and demeanours to be enjoined at the time of Divine Service and preaching:" this course being ultimately adopted, and an addition made by Convocation to the XVIIIth Canon, in consequence, on May 12th, 1662¹. (2) The second circumstance is thus stated in the Journals of the House of Lords, on the 8th of May, 1662: "Whereas it was signified by the House of Commons at the Conference yesterday that they found one mistake in the rubrick of Baptism, which they conceive was a mistake of the writer, *Persons* being put instead of *Children*, the Lord Bishop of Durham acquainted the house, that himself and the Lord Bishop of Carlisle had authority from the Convocation to amend the said word, averring it was only a mistake of the scribe; and accordingly they came to the Clerk's table, and amended the same²."

The amendments proposed by the House of Commons in the Act of Uniformity all tended to raise the tone in which the Prayer Book was to be used, and to make the provisions of the Act more strict. They especially required that the Surplice, and the Sign of the Cross in Baptism, should continue to be used. [Kennett's Reg., pp. 676. 679.] These amendments were all agreed to by the Lords on May 10th; and thus the Prayer Book, as amended by Convocation, and the Act of Uniformity, as amended by Parliament, both received the Royal Assent on May 19th, 1662.

In answer to inquiries from the House of Lords, the Bishops had guaranteed (on April 21st) that the Book should be in print and ready for use on August 24th, the Feast of St. Bartholomew, which was the day fixed by Parliament for the Act to come into operation. The printing was undertaken by Convocation, which, as early as March 8th, had appointed Dr. Sancroft to be Supervisor, and Messrs. Scattergood and Dillingham, Correctors of the press³. The following MS. entry on the fly-leaf of Bishop Cosin's Durham Book, in the Bishop's own hand, will show how much anxious thought he had taken for this and all other matters connected with the Revision of the Prayer Book:—

"Directions to be given to the printer.

"Set a fair Frontispiece at the beginning of the Book, and another before the Psalter, to be designed as the Archbishop shall direct, and after to be cut in Brass.

"Page the whole Book.

"Add nothing. Leave out nothing. Alter nothing, in what Volume soever it be printed. Particularly; never cut off the Lord's Prayer, Creed, or any Collect with an &c.; but wheresoever they are to be used, print them out at large, and add [Amen] to the end of every prayer.

¹ Kennett's Register, pp. 671. 680. 684.

² Kennett's Register, p. 680. An order for correcting this error had passed Convocation on April 21st. Ibid. p. 666.

A more curious slip of the pen is said to have been corrected with a bold readiness by Lord Clarendon. "Archbishop Tenison told me by his bedside on Monday, Feb. 12, 1710, that the Convocation book intended to be the copy confirmed by the Act of Uniformity had a rash blunder in the rubrick after Baptism, which should have run [*It is certain by God's word, that children which are baptized dying before they commit actual sin are undoubtedly saved*]. But the words [*which are baptized*] were left out, till Sir Cyril Wyche coming to see the Lord Chancellor Hyde found the book brought home by his lordship, and lying in his parlour window, even after it had passed the two houses, and happening to cast his eye upon that place, told the Lord Chancellor of that gross omission, who supplied it with his own hand." Ibid. p. 643. This story was fifty years old when it reached

Bishop Kennett, but it has an air of probability: and such strange accidents in the most important matters have not unfrequently occurred. So the word "not" was once omitted from the seventh commandment in a whole edition of the Holy Bible; the printers being heavily fined for the mistake.

³ Among Archbishop Sancroft's MSS. in the Bodleian, there is a letter from one of Bishop Cosin's chaplains, written from Bishop Auckland on June 16th, 1662, in which he says, "My lord desires at all times to know particularly what progress you make in the Common Prayer." There is also a mandate from Charles II. to the Dean and Chapter of Durham among the State Papers, dated June 16th, 1662, likewise, and ordering them to dispense with Prebendary Sancroft's residence, as he "has been for some months, and still is attending the impression of the Liturgy;" and adding that "it is not the meaning of the statutes to require the residence of members of the Chapter when service of greater use to the Church requires them." State Papers, lvi. 61.

- “ Never print the Lord’s Prayer beyond—‘ deliver us from evil. Amen.’
 “ Print the Creeds always in three paragraphs, relating to the three Persons, &c.
 “ Print not Capital letters with profane pictures in them.
 “ In all the Epistles and Gospels follow the new translation.
 “ As much as may be, compose so that the leaf be not to be turned over in any Collect, Creed, Verse of a Psalm, Middle of a sentence, &c.
 “ Set not your own Names in the Title-page nor elsewhere in the Book, but only ‘ Printed at London by the printers to the King’s most excellent Majesty. Such a year.’
 “ Print [Glory be to the Father, &c.] at the end of every Psalm, and of every part of *civic*. Psalm.

“ In this Book :—

- “ Where a line is drawn through the words, that is all to be left out.
 “ Where a line is drawn under the words, it is to be printed in the Roman letter.
 “ Where a prickt line is drawn under the words, it is not part of the book, but only a direction to the printer or reader.
 “ Where this note [is set, a break is to be made, or a new line begun.
 “ Where a double line is drawn under any words, they are to be printed in Capitals ¹.”

While the Act of Uniformity was passing through Parliament, the House of Commons inserted a clause which provided that “ a true and perfect copy of this Act, and of the said Book annexed hereunto,” should be provided by the Deans and Chapters of every Cathedral or Collegiate Church before Christmas Day, obtained “ under the Great Seal of England,” and also that similar copies should be delivered into the respective Courts of Westminster, and into the Tower of London, to be kept and preserved as records. It was also provided that these books should “ be examined by such persons as the King’s Majesty shall appoint under the Great Seal of England for that purpose, and shall be compared with the original Book hereunto annexed.” These Commissioners were to have power “ to correct, and amend in writing, any error committed by the Printer in the printing of the same book, or of any thing therein contained, and shall certify under their hands and seals . . . that they have examined and compared the said Book, and find it to be a true and perfect Copy.” The Prayer Books so certified and sealed with the Great Seal were then enacted to be as good Records as the MS. itself.

Soon after the Book was printed, a Commission was therefore issued: a strong Royal mandate having been meanwhile sent to the University of Cambridge, commanding the Vice-Chancellor to inhibit the University printers from sending out any copies printed otherwise than was allowed them². The Commission was dated Nov. 1st, 1662, and was addressed to twenty-five persons, of whom seven or eight appear to have constituted the working part of the Commissioners, their names being found repeated in several of the Sealed Books. Certain alterations were made, chiefly in the headings and titles of Prayers, Psalms, &c., in all the Books which were to receive the Great Seal; and a Certificate was appended to each of them, signed by the Commissioners on December 13th. The Books so certified were afterwards ordered to be passed under the Great Seal, and as many copies sealed as the Lord Chancellor thought fit³, Letters Patent, dated January 5th, 1662-3, being appended to each. Thus the Book of Common Prayer was carefully guarded through every stage of its preparation, that it might go forth to the people of England with all the authority that law can give, and that a perfect Record might never be wanting of the true document by which the system of Divine Service is regulated in the Church of England. [See the frontispiece.]

An attempt was made in the reign of William III. to remodel the Prayer Book on principles much less Catholic than those which had been uniformly adopted in former revisions, but the attempt happily failed⁴. No further alteration of its pages has taken place, and the Prayer Book of 1662 is still the Prayer Book of the Church of England in 1866.

¹ It is very singular that Burton had alleged, some five-and-twenty years before, that there was “ in the great printing house at London a Common Prayer Book,” altered with Cosin’s hand, to show “ how he would have it altered.” Fryne makes a somewhat similar assertion in his criticism of Cosin’s Devotions, printed in 1626 and 1627. [Lathbury’s Convocation, p. 273.] These anticipations of Cosin’s influence show that he was marked out for a leader in the work of revision.

² State Papers, Domestic, Charles II., lviii. 42.

³ Ibid. lxi. 144; lxiii. 42.

⁴ The whole of the proposed Revision of 1689 was printed in a “ blue book ” by order of the House of Commons, dated June 2nd, 1854. A full account of it is also given in Procter’s History of the Common Prayer, pp. 144—160. As it has never had any authority or influence, it has been considered unnecessary to give any particulars respecting it here.

§ *National Versions of the Prayer Book.*

The English system of Divine Service was adopted by the Church of Scotland in the seventeenth century, and by that of the United States of America in the eighteenth: and although the Churches of both countries are but small bodies, when compared with the numbers of the population, the versions of the Book of Common Prayer adopted by them have an historical claim to be called national versions,—that of Scotland having been adopted under royal and ecclesiastical authority, while that of America was adopted under the most authoritative sanction of the ecclesiastical body to which the original English colonists of the continent belonged.

The Reformation was not carried forward in Scotland with the same calm, dispassionate, and humble reverence for the old foundations which was so conspicuous in that of the Church of England. For many years no uniform system of devotion took the place of the ancient offices, and it was not until the reign of James I. that any endeavour was made to put an end to that ecclesiastical anarchy which was thinly veiled by Knox's miserable Book of Common Order. The General Assembly of 1616 agreed to the proposal that a national Liturgy should be framed: but King James wished to introduce the English Prayer Book, and it was used in his presence at Holyrood on May 17th, 1617. Three years afterwards an Ordinal was published for the use of the Scottish Church; and the draft of a Liturgy was submitted to the King by Archbishop Spottiswoode. This was revived on the accession of Charles I., and in 1629 official measures were taken for obtaining its reconsideration and adoption by the Church of Scotland; although both the King and Laud were anxious to have the English Prayer Book introduced without alteration. Eventually the King gave way to the wish of the Scottish Bishops that a national form of Divine Service should be adopted: an episcopal committee was appointed (of whom Maxwell, Bishop of Ross, and Wedderburn, Bishop of Dumblane, appear to have been the most active), and they were engaged on the work for many months, some delay being caused, apparently, by the necessity of communicating with the King and the Archbishop of Canterbury, which had arisen from the altered relations of the two countries. The Scottish Prayer Book of 1637 was the result of these labours.⁶ It has been popularly connected with the name of Archbishop Laud, but it was the compilation of Scottish Bishops; and all the English Archbishop did was (as one of a commission of which Wren and Juxon were the other two members) to offer suggestions, prevent rash changes, communicate between the Crown and the Scottish Bishops respecting alterations, and facilitate the progress of the book through the press.

The Book of Common Prayer so prepared was not submitted to the General Assembly of the Church of Scotland. As the preceding pages have shown, the English book was, from first to last, the work of Convocation; and no doubt the Scottish book ought also to have had the sanction at least of the whole Scottish Church by representation, and not only of the Crown and the Bishops. In the year 1637 it was imposed upon the Church of Scotland by letters patent and the authority of the Bishops: but, as is well known, its introduction was vigorously opposed by a fanatical faction which in the end became supreme, and both the Church and the Prayer Book of Scotland were suppressed. That now in use in the Scottish Church was introduced in later times; but the book of 1637 is so much connected with the history of the period, and has, besides, so much liturgical interest, that a fuller notice of it has been inserted in the Appendix at the end of this work.

The American Prayer Book. Until the separation of the North American colonies from England, the English Book of Common Prayer was used without any alteration in the American Church. After they became independent, as the United States, it was thought expedient for the Church to make some changes, especially as alterations were being introduced without authority, and there seemed danger of much disorder in Divine worship if a form were not adopted which could have some claim to be called national. The first step towards this was taken at the General Convention of the American Church held at Philadelphia in 1785: during the next four years the various Offices were gradually remodelled until they took the form in which they are now used, and which was authorized by the General Convention of 1789. Committees had been appointed to prepare an entirely new book: but in the end the English Prayer Book was taken as the basis to be adopted. The language was in many parts modernized, the Communion Office was restored to a form similar to that of 1549, a selection of Psalms was appointed instead of our daily order, the use of the Athanasian Creed was discontinued, and some other less

important alterations were made. But the Preface declares that the American Church "is far from intending to depart from the Church of England in any essential point of doctrine, discipline, or worship, or farther than local circumstances require."

§ *Translations of the Prayer Book.*

The Book of Common Prayer arose, in no small degree, from a conviction, on the part of the Clergy and Laity of England, that Divine Service should be offered to God in the vernacular tongue of those on whose behalf and by whom it is being offered. The principle thus adopted in respect to themselves has been carried out as far as possible in all the missionary operations of the Church of England; and the establishment of her forms of Divine Service in countries where the English language is not freely spoken, has generally been accompanied by the translation of the Book of Common Prayer into the language of those who are being won over to the Church of Christ. A necessity has also arisen for translations into some European languages: while provision was made for rendering it into Welsh and Irish at the time of its first issue. An account of the Latin translation will be found under the rubric relating to the use of Divine Service in other languages than the English p. 18].

The following list contains the names of forty languages and dialects, into which the Book of Common Prayer has been translated, but the number is constantly increasing as the missionary work of the Church is developed:—

Latin	Italian	Bengali	Bulloa
Greek	Dutch	Hindi	Yoruban
Hebrew	Danish	Burmese	Malay
Welsh	Russian	Mahratta	Dyak
Irish	Polish	Tamil	Singhalese
Gaelic	Modern Greek	Susu	Indo-Portuguese
Manks	Persian	Amharic	Cree
French	Turkish	Telugoo	Malagasy
German	Armenian	Chinese	Maori
Spanish	Armeno-Turkish	Hawaiian	
Portuguese	Arabic	Kafir	

Most of these translations have been produced under the auspices of the Society for Promoting Christian Knowledge, and of the Prayer Book and Homily Society; and some guarantee is thus given for accuracy. It should also be mentioned as a fact of interest and importance that the Hawaiian version was made in 1863 by the native king, Kamehameha IV., who also annexed to it a Preface which shows a thorough knowledge of the principles of the Prayer Book.

A

RITUAL INTRODUCTION

TO THE

PRAYER BOOK.

SECTION I.

THE PRINCIPLES OF CEREMONIAL WORSHIP.

FORMS and ceremonies in Divine Service are bodily manifestations of spiritual worship, and the ordinary means by which that worship is expressed to God.

The whole scheme of Redemption is based on a principle which shows that God establishes communion between Himself and mankind chiefly through the body and bodily acts, and not through purely mental ones, as the exercise of thought or will. For when a perfect and unimpeded spiritual intercourse was to be renewed between the Creator and His fallen creatures, God, Who "is a Spirit," took upon Him a bodily nature, and by means of it became a Mediator, through Whom that intercourse could be originated and maintained. For the particular application, also, of the benefits of His mediation, Christ ordained Sacraments, which are outward and visible signs endowed with the capacity of conveying inward and spiritual grace to the soul through the organs of the body.

In analogy with this principle, Ceremonial worship, or Ritual, may be defined as the external body of words and actions by which worship is expressed and exhibited before God and man. As it is ordained that men shall tell their wants to God in prayer, although He knows better than they know themselves what each one's necessities are, so it is also ordained that spiritual worship shall be communicated to Him by words and actions, although His Omniscience would be perfectly cognizant of it without their intervention.

The Divine Will on this subject has been revealed very clearly and fully in the Holy Bible; from its earliest pages, which record the sacrifices of Cain, Abel, and Noah, to its latest, in which the worship of Heaven is set forth as it will be offered by the saints of God when the worship of Earth will have passed away.

Before the origination of the Jewish system of ceremonial, we find customs which indicate the use of certain definite forms in acts of Divine worship. The chief of these is Sacrifice, in which the fruits of the earth were offered to God, or the body of some slain animal consumed by fire on His altar. Such acts of sacrifice were purely ceremonial, even supposing them to have been unaccompanied by any words; and the account of Abraham's sacrifice, in Genesis xv. 9—17, illustrates very remarkably the minute character of the ritual injunctions given by God even before the time of the Mosaic system. The Divine institution of the outward ceremony of Circumcision is another instance of the same kind, and one of even greater force, from the general and lasting nature of the rite as at first ordained; a rite binding on the Jewish nation for nearly two thousand years. Another ceremonial custom to be observed in the Patriarchal times, is that of "bowing down the head" when worshipping the Lord [Gen. xxiv. 26. 48]; another, that of giving solemn benedictions, accompanied by laying on of hands [Gen. xxvii. 27—29; xxviii. 1—4; xlvii. 10; xlviii. 9—20]; another, that of setting up a pillar, and pouring oil upon it [Gen. xxviii. 18; xxxv. 14]; another, purification before sacrifice [Gen. xxxv. 2]; and, to name no more, one other, the reverent burial of the dead [Gen. xxiii. 19; xxxv. 19; 1. 10], which even then was an act of reverence towards God, as well as of respect and affection towards the departed.

The introduction of a higher form of corporate worship was accompanied by a great development of

ceremony or ritual. Of what was previously in use, we can only infer that it was divinely instituted; but the divine institution of the Jewish system of ritual is told us in the most unmistakeable terms in the Holy Bible, and the narration of it occupies more than seven long chapters of the Book of Exodus [xxiv.—xxxi.], together with the greater part of the twenty-seven chapters of Leviticus.

This system of ritual (sometimes called "Mosaic," but in reality Divine) was revealed with circumstances of the utmost solemnity. After a preparation of sacrifices, Moses, Aaron, Nadab and Abihu, and the seventy elders, went up into the lower part of Mount Sinai, and from thence "they saw the God of Israel: and there was under His feet as it were a paved work of a sapphire stone, and as it were the body of Heaven in clearness." Moses was then commanded to go up to the summit of the mountain, "and a cloud covered the mount. And the glory of the Lord abode upon Mount Sinai, and the cloud covered it six days: and the seventh day He called unto Moses out of the midst of the cloud. And the sight of the glory of the Lord was like devouring fire on the top of the mount in the eyes of the children of Israel. And Moses went into the midst of the cloud, and gat him into the mount: and Moses was in the mount forty days and forty nights" [Exod. xxiv. 9—18]. During this awful time of converse between God and His servant Moses, it appears that the one subject of revelation and command was that of ceremonial worship: the revelation of the moral law being recorded in the single verse, "And He gave unto Moses, when He had made an end of communing with him upon Mount Sinai, two tables of testimony, tables of stone, written with the finger of God" [Exod. xxxi. 18].

The revelation of God's will respecting forms and ceremonies, which was thus awfully given to Moses, went into very minute particulars, which were chiefly respecting the construction of the Tabernacle, the dress of those who were to minister in it, the *instrumenta* of Divine Service, and the ceremonies with which that service was to be carried on. The architecture of the structure itself, the design of its utensils, and of the priestly vestments, and that kind of laws for the regulation of Divine Service which we now know as rubrics, were thus communicated to Moses by God Himself, and in the most solemn manner in which any revelation was ever given from Heaven. And when the revelation was completed, "the Lord spake unto Moses, saying, See, I have called by name Bezaleel the son of Uri, the son of Hur, of the tribe of Judah: and I have filled him with the Spirit of God, in wisdom, and in understanding, and in knowledge, and in all manner of workmanship. . . . And I, behold, I have given with him Aholiab, the son of Ahisamach, of the tribe of Dan: and in the hearts of all that are wise-hearted I have put wisdom, that they may make all that I have commanded thee" [Exod. xxxi. 1—6]. Thus Divine Inspiration was given to the principal architects and superintendents of the external fabric by means of which Divine Service was to be carried on, as well as a Revelation of its structure, and of the ceremonial itself; and no words can heighten the importance and value which Almighty God thus indicated as belonging to ceremonial worship.

Nor did this importance and value belong to ceremonial worship only in the early period of the Jewish nation's life. It was not given to them as a means of spiritual education, by which they should be gradually trained to a kind of worship in which externals should hold a less conspicuous position. Nothing whatever appears, in the revelation itself, of such an idea as this; but the ceremonial is throughout regarded as having reference to Him in Whose service it was used, looking to the Object of worship, and not to the worshippers. And accordingly, when the Jewish nation attained its highest pitch of prosperity, and probably of intellectual as well as spiritual progress, in the latter years of David and in the reign of Solomon, this elaborate system of ceremonial worship was developed instead of being narrowed. The magnificent preparations which David made for building the Temple are recorded in 1 Chron. xxii., xxviii., and xxix.; and those which he made for establishing the service there, in 1 Chron. xvi., xxiii.—xxvi.: the descriptions of the structure and of the utensils being almost as minute and detailed as in the commandments of God on Sinai respecting the Tabernacle. In this more intellectual age of the Jewish nation, and for this development of ceremonial worship, God vouchsafed to give inspiration to His servants for their work, as He had done to Bezaleel and Aholiab. When the Holy Bible gives the account of David furnishing Solomon with the designs for the Temple and its furniture, these significant words are added, "And the pattern of all that he had by the Spirit." Even more striking are David's own words: "All this the Lord made me understand in writing by His hand upon me, even all the works of this pattern. . . . The Lord God, even my God, will be with thee; He will not fail thee, nor forsake thee, until thou hast finished all the work for the service of the house of the Lord" [1 Chron. xxviii. 12. 19]. The fulfilment of this prophetic promise is indicated in a subsequent

place by the words, "Now these are the things wherein Solomon was instructed for the building of the house of God" [2 Chron. iii. 3]: and the Divine approval of all that was done is strikingly shown in 1 Kings ix. 3. 2 Chron. v. 11—14; and vii. 1, 2. Nor should the fact be overlooked that the most costly and beautiful house of God which the world ever saw was built, the most elaborate and gorgeous form of Divine Service established, by one who was no imaginative enthusiast, but by one whose comprehensive knowledge and astute wisdom exceeded those of any man who had ever before existed, and were perhaps greater than any learning or wisdom, merely human, which have since been known. Solomon was a man of science, an ethical philosopher, and a statesman, yet a ritualist.

Thus the use of Ceremonial Worship in some form is shown to have existed even in the simple Patriarchal ages; and to have been ordained in its most extreme form by God Himself in the times of Moses, David, and Solomon. Let it be reverently added, that it was this extreme form of Ceremonial Worship which our Lord recognized and took part in when He went up to Jerusalem to celebrate the great Festivals, and the restoration of which in its purity He enforced both at the beginning and end of His ministry by His "cleansing the Temple" from the presence of those who bought and sold there. The vain and empty private ceremonies which the Pharisees had invented met with the severe condemnation of our Lord; but there is not one act or word of His recorded which tends in the least towards depreciation of the Temple service; or which can lead to the supposition that the worship of God "in spirit and in truth" is to be less associated with forms and ceremonies when carried on by Christians, than when it was offered by Moses, David, Solomon, and the Old Testament saints of many centuries.

The ritual practices of the Apostolic age are to some extent indicated in the New Testament, but as the Temple service was still carried on, and Jerusalem formed the religious centre of the Apostolic Church, it is clear that an elaborate ceremonial was not likely to be established during the first quarter of a century of the Church's existence. Yet this earliest age of the Church witnesses to the *principle* of ceremonial worship, as the Patriarchal age had done; and each foreshadowed a higher development of it. A learned German ritualist has written thus on this subject:—"On mature reflection, I am satisfied that the Apostles by no means performed the Divine Liturgy with such brevity, at least as a general rule, as some have confidently asserted. The faithful, whether converts among the Jews or Gentiles, were accustomed to ceremonies and prayers in their sacrifices; and can we suppose that the Apostles would neglect to employ the like, tending so greatly as these must do to the dignity of the service, and to promote the reverence and fervour of the worshipper? Who can believe that the Apostles were content to use the bare words of consecration and no more? Is it not reasonable to suppose that they would also pour forth some prayers to God, especially the most perfect of all prayers which they had learned from the mouth of their Divine Master, for grace to perform that mystery aright; others preparatory to communion, and again, others of thanksgiving for so inestimable a benefit?" [Krazer de Liturgiis, i. 1—3.]

But there are distinct traces of actual forms of service in the Acts of the Apostles, and in some of the Epistles. In the second chapter of the former, at the forty-second verse, it is said of the first Christians that they continued stedfastly in *the doctrine* [τῇ διδαχῇ] and in *the fellowship* [τῇ κοινωνίᾳ] of the Apostles; and in *the breaking of the Bread* [τῇ κλάσει τοῦ ἄρτου], and in *the prayers* [ταῖς προσευχαῖς]; the two latter expressions clearly indicating settled and definite ceremonial usages with which the writer knew his readers to be acquainted. St. Paul's reference to a Sunday offertory [1 Cor. xvi. 1]; to the observance of decency and order in the celebration of Divine Service [1 Cor. xiv. 40]; to the ordinances, or traditions, which he had delivered to the Corinthians, and which *he had received from the Lord Himself* [1 Cor. xi. 2]; and to the divisions of Divine Service in his words, "I exhort, therefore, that first of all, supplications [δεήσεις], prayers [προσευχὰς], intercessions [ἐντεύξεις], and Eucharists [εὐχαριστίας], be made for all men" [1 Tim. ii. 1],—these show that an orderly and formal system was already in existence; while his allusion to "the traditions" [τὰς παραδόσεις] seems to point to a system derived from some source the authority of which was binding upon the Church. Such an authority would attach to every word of our Blessed Lord; and when we know that He remained on earth for forty days after His Resurrection, and that during that period He was instructing His Apostles in "the things pertaining to the Kingdom of God" [Acts i. 3], it is most natural to suppose that the main points of Christian ritual were ordained by Him, as those of the Jewish ritual had been ordained during the forty days' sojourn of Moses on Sinai. It is to be remembered also that there are forms and ceremonies in use by the Church which were undoubtedly ordained by Christ, such as the

laying on of hands in Ordination, the use of water and certain words in Holy Baptism, and the manual ceremonies at the Holy Communion.

At a later period, when the Temple service had altogether ceased, when the temporary dispensation of a miraculous Apostolate was drawing to a close, and when the Church was settling into its permanent form and habits, St. John (the last and most comprehensive of the Apostolic guides of the Church) wrote the book of the Revelation; and several portions of it seem intended to set forth in mystical language the principles of such ceremonial worship as was to be used in the Divine Service of Christian churches. In the fourth chapter, the Apostle is taken up to be shown, as Moses had been shown, a "pattern in the Mount;" and as that revelation to Moses began to be made on the Sabbath of the old Dispensation, so it was "the Lord's Day" on which St. John was "in the Spirit," that he might have this new revelation made to him. As, moreover, the revelation made to Moses was one respecting the ritual of the Jewish system, so there is an unmistakeable ritual character about the vision first seen by St. John; the whole of the fourth and fifth chapters describing a scene which bears a close resemblance to the celebration of the Holy Eucharist, as it was celebrated in the early ages of the Church, and as it is still celebrated in the East.

The form and arrangement of churches in primitive times was derived, in its main features; from the Temple at Jerusalem. Beyond the porch was the narthex, answering to the court of the Gentiles, and appropriated to the unbaptized and to penitents. Beyond the narthex was the nave, answering to the court of the Jews, and appropriated to the body of worshippers. At the upper end of the nave was the choir, answering to the Holy Place, for all who were ministerially engaged in Divine Service. Beyond the choir was the Bema or Chancel, answering to the Holy of Holies, used only for the celebration of the Holy Eucharist, and separated from the choir by a closed screen, resembling the organ screen of our cathedrals, which was called the Iconostasis. As early as the time of Gregory Nazianzen, in the fourth century, this screen is compared to the division between the present and the eternal world [Carm. xi.], and the sanctuary behind it was ever regarded with the greatest reverence as the most sacred place to which mortal man could have access [Chrys. in Eph. Hom. iii.]; the veiled door which formed the only direct exit from it into the choir and nave being only opened at the time when the Blessed Sacrament was administered to the people there assembled. The opening of this door, then, brought into view the Altar and the Divine mysteries which were being celebrated there. And when St. John looked through the door that had been opened in Heaven, what he saw is thus described: "And behold a Throne was set in Heaven . . . and round about the Throne were four and twenty seats; and upon the seats I saw four and twenty elders sitting, clothed in white raiment; and they had on their heads crowns of gold: . . . and there were seven lamps of fire burning before the Throne . . . and before the Throne there was a sea of glass like unto crystal." Here is exactly represented an arrangement of the altar familiar to the whole Eastern Church and to the early Church of England, in which it occupies the centre of an apse in front of the seats of the Bishop and Clergy, which are placed in the curved part of the wall. And, although there is no reason to think that the font ever stood near the altar, yet nothing appears more likely than that the "sea of glass like unto crystal" mystically represents that laver of regeneration through which alone the altar can be spiritually approached. Another striking characteristic of the ancient Church was the extreme reverence which was shown to the book of the Gospels, which was always placed upon the altar and surmounted by a cross. So "in the midst of the Throne, and round about the Throne," St. John saw those four living creatures which have been universally interpreted to represent the four Evangelists or the four Gospels; their position seeming to signify that the Gospel is ever attendant upon the altar, penetrating, pervading, and embracing the highest mystery of Divine Worship, giving "glory and honour and thanks to Him that sat on the throne, who liveth for ever and ever." In the succeeding chapter St. John beholds Him for whom this altar is prepared. "I beheld, and lo, in the midst of the Throne, and of the four living creatures, and in the midst of the elders, stood a Lamb as if it had been slain, having seven horns and seven eyes, which are the seven spirits of God sent forth into all the earth." It cannot be doubted that this is our Blessed Lord in that Human Nature on which the *septiformis gratia* was poured without measure; and that His appearance in the form of "the Lamb that was slain to receive power, and riches, and wisdom, and strength, and honour, and glory, and blessing," represents the mystery of His prevailing Sacrifice and continual Intercession. But around this living Sacrifice there is gathered all the homage of an elaborate ritual. They who worship Him have "every one of them harps," to offer Him the praise of instrumental music; they have "golden vials full of incense, which are the prayers of

saints," even as the angel afterwards had "given unto him much incense that he should offer it with the prayers of the saints upon the golden altar which was before the Throne¹:" they sing a new song, mingling the praises of "the best member that they have" with that of their instrumental music; and they fall down before the Lamb with the lowliest gesture of their bodies in humble adoration. Let it also be remembered that one of the Anthems here sung by the choirs of Heaven is that sacred song, "Holy, Holy, Holy, Lord God Almighty, which was, and is, and is to come;" the Eucharistic use of which is traceable in every age of the Church,

These striking coincidences between the worship of Heaven revealed to St. John and that which was and is offered at the altars of the Church on earth, warrant us in considering this portion of the Revelation as a Divine treasury wherefrom we may draw the principles upon which the worship of earth ought to be organized and conducted. And the central point of the principles thus revealed is that there is a Person to be adored in every act of Divine Worship now, as there was a Person to be adored in the system which culminated in the Temple Service. This Person is moreover revealed to us as present before the worshippers. And He is further represented as our Redeeming Lord, the "Lamb that was slain," He who said respecting Himself to St. John at the opening of the Apocalyptic Vision, "I am He that liveth and was dead, and am alive for evermore."

This Presence was promised by our Blessed Lord in words which the daily prayer of the Church interprets to have been spoken with reference not only to Apostolic or Episcopal councils, but also to Divine Service: "Where two or three are gathered together in My Name, there am I in the midst of them." [Matt. xviii. 20.] It is quite impossible to view this promise in the light of Holy Scripture, and especially of that part of the Revelation which has been referred to above, without seeing that its *fullest* and *most essential* meaning connects it with the Eucharistic Presence of Christ, the "Lamb as it had been slain." This truth so pervaded the mind of the ancient Church that in its primitive ages Divine Service consisted of the Holy Eucharist only²; and the early Liturgies speak to Christ in such terms as indicate the most simple and untroubled Faith in the actual Presence of our "Master" and Lord³. Hence the Ceremonial Worship of the early Church was essentially connected with this Divine Service; and to those who were so imbued with a belief in the Eucharistic Presence of their Lord the object of such ceremonial was self-evident. The idea of reflex action upon the worshipper probably never occurred to Christians in those times. Their one idea was that of doing honour to Christ, after the pattern of the four living creatures, the four and twenty elders, the angels, and the ten thousand times ten thousand and thousands of thousands who said "Worthy is the Lamb:" after the pattern of those who, even in Heaven, accompanied their anthems with the music of harps, and their prayers with the sweet odour of incense.

The mystery of our Lord's Presence as the Object of Divine Worship lies at the root of all the ceremonial practices of the Church: and a conviction that this Presence is vouchsafed chiefly through the Holy Eucharist causes the latter to become the visible centre from which all ritual forms and ceremonies radiate. It is true that there are some ceremonies which may be said to belong to the organization of Divine Service; but even that organization is linked on to acts of worship, since it is in the service of God, who enjoins order, and exhibits it in all His works. But this latter class of ceremonies is not large, and scarcely affects the general principle which has been previously stated. There are, again, some ceremonies which may be called educational or emotional in their purpose, but they are so only in a secondary degree; and such a character may be considered as accidentally rather than essentially belonging to them.

The principles of Ceremonial Worship thus deduced from Holy Scripture may be shortly applied to some of the more prominent particulars of the ritual of the Church of England, leaving exact details for the two subsequent sections of this Introduction, and the Notes throughout the work.

1. The local habitation provided for the welcome of our Lord's mystical Presence is provided of a character becoming the great honour and blessing which is to be vouchsafed. It is the House of God, not man's house; a place wherein to meet Him with the closest approach which can be made in this

¹ It is observable that the incense is not a symbolical figure for prayer, but is said to be offered in combination with prayer. [Rev. viii. 3, 4.]

² The Holy Eucharist was the only distinctively Christian part of Christian worship. The "hours of prayer," now represented

by our Mattins and Evensong, were derived from the Jewish ritual; and the Christians of Jerusalem evidently "went up to" those of the Temple Service while it lasted.

³ See a prayer at p. 27, from the Liturgy of St. Mark, but addressed to the First Person of the Blessed Trinity.

life. Hence, if Jacob consecrated with the ceremony of unction the place where God made His covenant with him, and said of it, "This is none other but the house of God, and this is the gate of heaven;" so should our churches be set apart and consecrated with sacred ceremonies making them holy to the Lord. So also, because they are to be in reality, and not by a mere stretch of language, the Presence chambers of our Lord, we must regard them as the nearest to heaven in holiness of all places on earth by the virtue of that Presence. And, lavishing all costly material, and all earnest skill upon their first erection and decoration, we shall ever after frequent them with a consciousness that "the Lord is in His holy Temple," and that all which is done there should be done under a sense of the greatest reverence towards Him.

2. Hence too, the furniture of the House of God, the utensils or *instrumenta* necessary for Divine Service, should all be constructed with a reverent regard to the Person in whose service they are to be used. Costly wood or marble, precious metals and jewels, used for such an object, do not minister to luxury, and have no direct and primary reference at all to those who will use them or look upon them. But as ministering to the honour of Christ our Lord they cannot be too freely used: nor need we ever fear of expending wealth or skill too abundantly when we read of the manner in which God accepted all that Solomon had done for His holy Temple at Jerusalem, and all the beauty and splendour with which He is worshipped in Heaven. The same principle applies with equal force to the apparel in which the ministers of God carry on His Divine Worship; surplice and albe, cope and vestment, all being used in His honour and for no other primary object whatever. If they are not necessary for the honour of God, the greater part of them are not needed at all.

3. The use of instrumental music, of singing, and of musical intonation, instead of colloquial modes of speech, are all to be explained on the same ground. Universal instinct teaches that the praises of God ought to be sung, and that singing is the highest mode of using in His service the organs of speech which He has given us. An orderly musical intonation is used by priest and people in their prayers, that they may speak to their Maker otherwise than they would speak to their fellow-men, acknowledging even by their tone of voice that He is to be served with reverence, ceremony, and awe.

4. And, lastly, the gestures used in Divine Service are used on similar principles. Kneeling in prayer, standing to sing praise, turning towards the East or the Altar when saying the Creeds, humbly bowing the head at the Name of Jesus or of the Blessed Trinity,—these are all significant gestures of reverence towards One who is really and truly present to accept the worship which they offer; One who accepts such reverence from the holy Angels and the glorified Saints, and who will not be otherwise than willing to receive it from His ministers and members in the Church on earth.

These, then, are the principles of Ceremonial Worship which pervade the Book of Common Prayer; and for the practical expression of which provision is made in the rubrics and in the ritual tradition to which the rubrics directly or indirectly point. They are principles which were originally laid down with the most awful solemnity by God Himself; which were not abrogated by any act or word of our Lord when He was upon earth; which were illustrated afresh on the first formation of the Christian Church in as solemn a manner as that in which they were originally enunciated; which were practically adopted by those Christians who lived nearest to the time of our Lord's ministry and teaching; and which have been followed out in our own Church from the most ancient days. The particular manner in which these Divinely revealed principles of Ceremonial Worship are practically applied to Divine Service as regulated by the present rules of the Church of England will be shown in the following sections.

SECTION II.

THE MANNER OF PERFORMING DIVINE SERVICE.

THE performance of Divine Service may be regarded in a twofold relation; as it affects the eye, and as it affects the ear. In other words, it may be considered as coming within the province, and under the superintendence of, one or other of the two representative Church officers, the Sacrist and the Precentor. In the present section some remarks will be offered upon it under its latter aspect, as it bears upon the subject of Church Music.

In looking, then, from the Precentor's point of view, at the question of the manner of performing

Divine Service in the Church of England, the first thing which strikes us is this,—that the directions in our Prayer Book, although scanty, are yet full of significance, implying much more than they seem actually to express. They carry us back to former times for their elucidation, and obviously assume a certain amount of familiarity with pre-Reformation usage. Thus the very brevity of our musical rubrics is one of their most interesting features, as necessarily presupposing a former history, and as referring us to that history for the completion and explanation of their concise verbal injunctions.

There is a world of meaning in the simple little word “Evensong,” as applied to our daily Evening Office. So again, such brief notices as, “here followeth the anthem;” “then shall be said, or sung;” “here shall follow;” “then shall be read;” “here the Priest and Clerks shall say;” “these Anthems shall be sung or said;” with many others, all seem to demand some additional explanation over and above what their words actually express.

But before directing attention to the musical notices of our Prayer Book, and their immediate history, it will be necessary to carry our thoughts further back, and see what is the ultimate basis on which they rest. And this will compel us to touch, though very briefly, on the subject of the Divine authority for the employment of music in the worship of Almighty God.

No lengthened remarks will be needed on this head. For the fact of music forming a recognized and Divinely ordained element in the public worship of God, and of the Almighty having herein given His deliberate sanction and approval to that which the instinctive piety of all nations has taught them, is familiar to all careful readers of Holy Scripture. Still it is well that Christians should have this truth, of the Divine origin and authority of Church music, firmly impressed on their minds; that they should be perfectly settled on this point, that it is not only not *wrong* to employ music freely in Divine Service, but a direct contravention of God’s revealed Will *not* to employ it, where it can be had; that Church music, therefore, should not be regarded with indifference, as a mere “non-essential,” but as a matter demanding earnest and reverent consideration.

We pass over the Antediluvian and Patriarchal times, as the notices of a definite and settled Ritual, and consequently of sacred music, are but slight. We pass over, also, the sojourn of the Chosen People in Egypt; and their wanderings in the desert. So long as God’s Church was in poverty, and under persecution, struggling for existence, and unable, through sheer necessity, to “put on her garments of praise,” God (in Jewish, as afterwards in Christian times) waived her becoming tribute and “Service of Song.” We must not look for our example to a state of things confessedly abnormal and transitory. We must refer to a period when the Church was able, through her outward circumstances, to give that full ritualistic form and expression to her worship which God deemed consistent with the duty she owed to Him¹. Let us at once pass on, then, to the period of King David.

The first great religious celebrations in his reign took place in connexion with the removal of the Ark from its place of banishment (after it had been captured by the Philistines in the time of Eli) to its resting-place on Mount Sion. There were two grand Choral Processional Services in connexion with this removal. The former of these, in consequence of certain ritual irregularities which offended God, came to a sad and untimely close. [1 Chron. xiii. 8—12; xv. 11—16.] The latter is the one which, as meeting with God’s express approbation, especially demands our notice. It is in reference, then, to this second and successful ceremonial, that we read of David, by God’s appointment, “speaking to the chief of the Levites to appoint their brethren to be the singers with instruments of musick, psalteries and harps and cymbals, sounding, by lifting up the voice with joy.” “Thus all Israel”—the narrative proceeds—“brought up the Ark of the Covenant of the Lord with shouting, and with sound of the cornet, and with trumpets, and with cymbals, making a noise with psalteries and harps” [1 Chron. xv. 28].

Nor was the work of Praise at an end. So soon as the solemn business of the Translation of the Ark is over, there must still be a special festival of Thanksgiving in commemoration of the auspicious event, as well as provision made for a *continuous* service of Praise. Hence David “appointed certain of

¹ “In *Egypt*,” writes Hooker, “it may be God’s people were right glad to take some corner of a poor cottage, and there serve God upon their knees; peradventure, covered with dust and straw sometimes. . . . In the *Desert*, they are no sooner possessed of some little thing of their own, but a Tabernacle is required at their hands. Being planted in the land of *Canaan*, and having David to be their King, when the Lord had given

him rest, it grieved his righteous mind to consider the growth of his own estate and dignity, the affairs of Religion continuing still in the former manner. What he did propose it was the pleasure of God that Solomon his son should perform; and perform in a manner suitable to their *present*, not to their *ancient* state and condition,” &c. [Ecc. Pol. IV. ii. 4.]

the Levites to minister before the Ark of the Lord, and to record, and to thank and praise the Lord God of Israel;” some “with psalteries and harps;” some to make “a sound with cymbals;” besides “the priests with trumpets continually before the Ark of the Covenant of God.”

Then it was, that “David delivered first this Psalm to thank the Lord [Ps. cv.] into the hand of Asaph and his brethren: ‘Give thanks unto the Lord, call upon His Name . . . sing unto Him, *sing Psalms* unto Him . . . Sing unto the Lord, all the earth: show forth from day to day His salvation.’”

And that the words of this Song should be practically realized, and the offering of Praise not cease with the festive occasion which had drawn forth the Psalm, we read of “Asaph and his brethren” being “left before the Ark of the Covenant to minister continually;” of “Heman and Jeduthun,” and others, “who were expressed by name,” “being chosen to give thanks to the Lord, with trumpets and cymbals . . . and with *musical instruments of God*” [1 Chron. xvi. 37. 41, 42]; of a great company of Levites being set by David “over the *Service of Song* in the House of the Lord, after the Ark had rest;” who “ministered before the dwelling-place of the Tabernacle of the Congregation with singing” [ib. vi. 31, 32]; and of “the singers, chief of the fathers of the Levites . . . who were employed in that work *day and night*” [ib. ix. 33]. And so highly developed did the musical department of the Divine Service become, that we see David, later in life, enumerating no fewer than “four thousand, who praised the Lord with the instruments which I made to praise therewith” [ib. xxiii. 5]. And lest we should deem these and kindred ritual arrangements of “the Man after God’s own heart,” “the Sweet Psalmist of Israel,” mere private unauthorized exhibitions of strong musical and æsthetic taste on the part of an individual monarch, we are expressly told in one place, that “all these things were done according to . . . the commandment of the Lord by His Prophets.” [2 Chron. xxix. 25.] Solomon carefully perpetuated all the musical arrangements of his father, and after the completion of his glorious Temple, according to the pattern shown him by God Himself, he transferred thither all the “*instruments*” which David had made for God’s service.

On the magnificent ceremonial of the Temple Dedication, with its gorgeous musical and ritual accessories [2 Chron. v. ; vii. 1—6], we need not dwell, since it is familiar to all; but it may be as well to remark that it is not for *nothing* that the Holy Ghost has thought fit to give us such an example of a Consecration Service. Surely if the ordinary bald Consecration and other Festal Services of modern times, with which we ourselves are familiar, are according to the Divine Mind, are suitable to the Dignity of HIM to Whom they are offered, and are adequate expressions before Angels and Men of His awful and “excellent Majesty,” this soul-stirring description would seem somewhat unnecessary, and hardly to have been “given for our learning.”

In proportion as subsequent monarchs neglected God, in that proportion did they cease to care for the Ritual of His House, and suffered the music of His Sanctuary to decline. And conversely, as any monarch was mindful of the Lord of Hosts, and zealous for His Honour, so do we ever see one token of his zeal and devotion in his reverent attention to the Ritual and the Music of God’s Holy Temple. Of Joash, of Hezekiah, of Josiah, the Holy Ghost recounts with special approbation their efforts for the restoration and encouragement of Church Music. But times grew darker. God’s people fell away from Him. They forgot that “God was their strength, and the High God their Redeemer.” The sad era of the Captivity ensued. The harps of Sion were hung on Babel’s willows. On the return from the Captivity we read of laudable and energetic attempts on the part of Ezra and Nehemiah to restore the ancient choral worship, and with a certain amount of success. But Israel’s glory was departed.

Thus we learn, even from this brief and incomplete survey, that God’s Church is emphatically “a singing Church;” that music, vocal and instrumental, is designed, by His express appointment, to constitute one essential element, one necessary feature, one integral part, of His public Ritual; that the *absence* of music and suitable ceremonial in the history of His ancient Church, is, in every case, not the result of His Will, but of man’s sinful disregard of that Will; an infallible sign, not of the faithfulness, but of the unfaithfulness of His people.

But has not Christianity introduced a change? At no time and in no manner has God ever given a hint that He has altered His will on this subject. Our Blessed Lord did not utter one single word in disparagement of the general principle of ceremonial worship, or of the ancient ritual, or music, of God’s Church. It was one of His chief earthly delights to take part in that worship Himself: and an elaborately ceremonial worship was the only public worship which He attended while sojourning here below. He was first discovered in His youth in His Father’s Temple. His first recorded words are, “Wist ye not that I must be *ἐν τοῖς τοῦ Πατρὸς μου;*” words which “remind the earthly mother

that it was in the courts of His Heavenly Father's House that the Son must needs be found; that His true home was in the Temple of Him Whose glories still lingered round the heights of Moriah¹. Do we not see Him here and elsewhere expressing in *deed* that which of old He expressed in *word* by the mouth of His "Sweet Singer,"—"Lord, I have loved the Habitation of Thy House . . . My soul hath a desire and longing to enter into the Courts of My God?"

And even after the Ascension, while we read of our Lord's chosen ones meeting together for their *private* celebrations of the Blessed Eucharist in their own consecrated Oratory, "the large Upper Room" (that sacred spot, hallowed first by the visible Presence of Christ, and then by that of the Holy Ghost), we find them exhibiting the effect of their Master's reverent example and teaching, by "*continuing*," none the less, "*daily, with one accord, in the Temple*," for the *public* worship of God.

Our Lord came, not to abolish, but to transfigure the old Ritual; not to diminish, but to increase its glory; to breathe into its dead forms a Divine and Life-giving Energy. Christian worship, at its first introduction, was not designed to supplant, but to supplement, the ancient Ritual. It was probably simple in outward character, as being only *private*; God's *public* worship being still entrusted to, and conducted by, the Ministers of the Old Dispensation. For a time, doubtless, the two went on simultaneously; the public worship of the Old, the private worship of the New Dispensation. The two were ultimately to be fused together: the outward and expressive forms of the Old, adapted, under the guidance of the Holy Ghost, to clothe the august realities of the New.

It is plainly recorded *when* and *where* the first Christian Service took place; viz. on the eve of our adorable Lord's Passion, and in "the large Upper Room"—hereafter to become the first Oratory of the Christian Church. Though outwardly, it may be, without pomp and show, as bearing on it the shadow of the great Humiliation to be consummated on the morrow, yet has the world never beheld, before or since, a Service of such surpassing dignity, sacredness, and significance. Here we witness the meeting-point of two Dispensations; the virtual passing away of the Law, and its transfiguration into the Gospel; the solemn Paschal close of the Old Economy, the Holy Eucharistic Inauguration of the New. Here we see the whole Representative Church assembled together with its Divine Head. And here we find every essential element of Christian Worship introduced and blessed by Incarnate God Himself. The grand central feature of the Service is the Holy Eucharist itself. Clustering round, and subsidiary to it, we find supplication, intercession, exhortation, benediction, excommunication, and Holy Psalmody: "after they had *sung* (*ὑμνήσαντες*) they went out to the Mount of Olives." Here, in the solemn Eucharistic Anthem which accompanied the first Celebration;—the Celebrant, God Incarnate, "giving Himself with His Own Hands;" and the Leader of the Holy Choir, God Incarnate, fulfilling His own gracious prediction, "In the midst of the Church will I sing praise unto Thee" (*ὑμνήσω σε*)—do we behold the Divine Source of that bright and ever-flowing stream of "Psalm, Hymn, and Spiritual Song," which was to "make glad the City of God."

In this august and archetypal Service, then, we see all those venerable *essentials* of Christian Worship which it would afterwards devolve upon the Church, under the guidance of the indwelling Spirit, to embody and express in her solemn Liturgies; and for the clothing and reverent performance and administration of which, it would be needful for her, under the same Holy Teaching, to borrow and adapt from that Divine Storehouse of Ritual which God had provided in the ancient Ceremonial².

¹ Ellicott, "Historical Lectures on the Life of our Lord," p. 93. 1st ed.

² Our English version, "breaking bread from house to house" [Acts ii. 46], would lead us to imagine, if it suggested the Eucharist at all, that this solemn Breaking of the Bread of Life—that "Bread which is the Communion of the Body of Christ"—took place irregularly, now in one private house, now in another. This is not, however, the meaning. *Kar' oikon* is not at *any* house, but "at home," at one particular house, or home. And where was the then Home of the Infant Church but that Sacred Place where the Holy Ghost had descended, "filling the whole *House* where they were sitting?" there, even in that "Large Upper Room," where the first Eucharist had been celebrated, where our Lord had appeared on two consecutive Sundays—"the Upper Room" [*τὸ ὑπερφῶν*, Acts i. 13], to which our Lord's chosen ones resorted after the Ascension in obedience to His command that they should not depart from

Jerusalem, but wait there for His Promised Gift, and "where abode Peter, and James, and John, and Andrew, Philip," &c. &c., who "all continued with one accord in prayer and supplication, with the women, and Mary the Mother of Jesus, and with His brethren."

³ It is necessary to bear in mind, not only what the Upper Room Service *was* designed, but also what it was *not* designed, to teach us. Some would gather from it a lesson *against* the use of solemn circumstance and ceremonial in Christian worship; but most incorrectly.

Passing over the significant notice, that the "Large Upper Room," even before any of the Holy Company entered it, was by God's secret Providence (working by human or angelic ministrations) "furnished and prepared"—words which *may* imply much—it must never be forgotten that, in the possibly simple arrangements of the Feast, there was something mysteriously in keeping with the then estate of Him who was to be Lord of the Feast.

But the chief point for us, at present, is this; that in the "*Hymn*" of our Ever-Blessed Redeemer we meet with a *new*, and, if possible, more constraining sanction to the use of Music in Divine Worship. We learn that the "Service of Song," ordained of old by God for His Church, and commended by so many marks of His approval, so far from being discountenanced by our Lord, was deliberately sanctioned, appropriated, perpetuated, re-consecrated, "for His Body's sake," by His own most blessed practice and example. Music was henceforth, no less than of old, to form one necessary adjunct, one essential element in Divine Worship. Nor must we fail to notice that, as music was doubtless intended to find its appropriate place throughout the *entire* offices of the Christian Church, even as the threefold division of Church Music into "Psalm, Hymn, Spiritual Song¹," twice emphatically repeated by the Holy Ghost, would seem to indicate, so its *special* home is the Liturgy. Wherever absent, it should not be absent here: and the *immediate* juxta-position of the Words of Institution, in both Gospels, with the mention of the Hymns, may be reverently conceived to teach this. So also does the Church seem instinctively to have felt: regarding the Holy Eucharist as the great centre round which her songs of praise should cluster and revolve; the great source from which they should take their rise, and flow forth. Pliny's mention of the early morning meetings of the first Christians to offer Divine Worship and sing hymns to Christ, probably refers to their Eucharistic assemblies. And Justin Martyr's expression must have a similar allusion, when he speaks of their offering up "solemn rites and hymns," *Πομπὰς καὶ ὕμνους*,—where the word *Πομπὰς* is interpreted by Grabius to denote the solemn prayers "in *Mysteriorum Celebratione*." [Apol. i. 13.]

With regard to the *nature* of the music used in God's Church in early times, we are utterly in the dark. Over the grand old Temple Music, in fact over the whole of the ancient Jewish Ritual Song, there is an impenetrable veil hanging. There are doubtless natural reasons which may, in a measure, account for the fact; especially this, that the ancient Jews seem to have possessed no musical characters; so that the melodies used in their services have been traditional, and as an inevitable consequence, more or less at the mercy of the singers. And we must further bear in mind that, ever since the woful time of the Captivity, the Holy Nation, instead of maintaining its ancient grand Theocratic independence, has been in subjection successively to all the great powers of the world; to the Babylonian, Medo-Persian, Græco-Macedonian dynasties; then, in turn, to Egypt and Syria; then to the mighty power of Rome. When we consider this, and take into account also their intestine factions, their constant unfaithfulness to God, their gradual loss therefore of their inward strength and glory, and with it of the beauty and completeness of that perfect Ritual which at once clothed, expressed, enshrined, and preserved their Holy Faith; can we wonder that, even before their dispersion into all lands, the memory of much of their own ancient music had faded away, and their Church song had lost its character, under the ever-varying heathen influences to which it had so long been incidentally subjected?

He had "emptied Himself;" and His voluntary self-abasement was on the eve of its full consummation. At this very Repast He suffers an Apostle to "lean on His Breast" in the unrestrained familiarity of friendly intercourse. From the loving and simple freedom, then, of this first Eucharist (in which God Incarnate was Himself the *visible* Celebrant) no single argument can be adduced against outward tokens of awe and reverence before our Lord's *supernatural* and *spiritual* Presence, which would not equally apply to His *natural* and *visible* Presence.

Our Lord is now "very highly exalted." The very same Apostle who here reclined on His Bosom, as on that of a dear friend, is careful to narrate to us how that, when next he beheld Him, after His entrance into Glory, he "fell at His feet as *dead*."

So, again, the Holy Ghost is no less careful to record, "for our learning," the solemn warning which the Christian Church so speedily received, as to the paramount *necessity* of fencing round this Holy Mystery with suitable ceremonial; telling us of the solemn judgments of the Most High upon those early communicants, who, presuming on the simple exterior of this august Service, ere yet the Church had been able to perfect her expressive Ritual, and approaching the Sacred Table without reverence, "not discerning the Lord's Body," and counting the "Blood of the Covenant" a "common thing," drew down upon them the

heavy wrath of God, being smitten with "grievous diseases, and sundry kinds of death."

¹ Eph. v. 19. Col. iii. 16.

In this threefold division, it is scarcely possible to miss some special secret relation with the three several Persons of the Ever-Blessed Trinity. (1) The "*Psalms*," flowing to us from, and uniting us to, the Old Dispensation, primarily lead us up to, and reveal to us, "the *Father* of an infinite Majesty." (2) The "*Hymns*," originating, as we have seen, from the Eucharistic Hymn in the Upper Room, bring us into special connexion with our *Lord Jesus Christ*. (3) The "*Spiritual Songs*," as their very name indicates, rather represent the free, unrestrained out-breathings in Holy Song of that Divine *Spirit* which animates and inspires the Body of Christ.

So that we find the *first* in our Psalters; the *second* chiefly in our Liturgical Hymns, "Gloria in Excelsis," "Ter Sanctus," and the like; the *third* in our metrical songs, or odes,—those songs in which Christian feeling has ever delighted to find expression.

The first class is rather occupied with God Himself; the second, with God in His dealings with man, through the One Mediator; the third, with man in his dealings with God, through the Spirit of God quickening him. Reverence and devotion speak in the first; dogma finds utterance in the second; Christian emotion in the third.

From the modern Jewish music we can learn nothing. Music, we are told, has been authoritatively banished from the Synagogue ever since the destruction of Jerusalem; the nation deeming its duty to be, rather to mourn over its misfortunes in penitential silence, until the Coming of Messiah, than to exult in songs of praise. Hence the music which still practically exists in so many Jewish congregations throughout the world, is more or less arbitrary, and destitute of traditional authority¹.

We are in equal doubt as to the nature of the ancient Christian music. All we know is that antiphonal singing was at a very early period introduced: in fact, there can be no reasonable doubt that it was a heritage bequeathed to the Christian Church from her elder Jewish sister, and that the Author of it was none other than the "Chief Musician" Himself. It was at Antioch, however, where the practice seems first to have systematically established itself, and whence it was ultimately spread over Christendom. This was a city of great importance in the history of Church Music. The Church in Antioch was the one which, next in order after that of Jerusalem, rose to pre-eminence. It was in a special way the mother and metropolis of Gentile Christendom. The very name *Christian* originated here. Socrates' account of the beginning of antiphonal singing in this city is too interesting to be passed over. The passage is thus given in Dr. Hanmer's translation (London, 1636):—

"Now let us record whence the hymnes that are song interchangeably in the Church, commonly called *Antemes* [Anthems], had their originall. Ignatius, Bishop of Antioch in Syria, the third Bishop in succession from Peter the Apostle, who was conversant, and had great familiarity with the Apostles, saw a vision of Angels which extolled the Blessed Trinity with Hymnes that were sung interchangeably: and delivered unto the Church of Antioch the order and manner of singing expressed in the Vision. Thereof, it came to passe, that every Church received the same tradition. So much of *Antemes*." [Soc. lib. vi. c. 12.]

Antioch, as capital of Syria, capital also of Roman Asia in the East, seems to have become a great intellectual as well as theological centre. Here we find the principal theological School of Syria and the East; a school exercising a great influence throughout Christendom². Antioch appears to have been the city in which Church Song first worked itself into shape; where Jewish tradition and Gentile intelligence met and blended; where the ancient Hebrew antiphonal system of Psalm recitation, and the shattered fragments of the old Ritual Song, allied themselves with, and were subjected to the laws of, modern Grecian musical science. It seems almost certain that Church music is rather Greek than Hebrew in origin. Hellenism had long been doing a Providential, though subsidiary work in preparing the world for Christianity. And though Greece had fallen under the iron grasp of the power of Rome, she had, in turn, subdued her conquerors to her literature, her language, and her arts. In the department of Christian Song, then, in the Church's first essays at giving musical expression to her sacred services, no doubt she would be mainly indebted to the science and skill of that nation which had already furnished her with a language, and which yet ruled the intellect of the world. The very names of the (so-called) ecclesiastical modes, or scales,—Dorian, Phrygian, Lydian, Mixo-Lydian, &c.,—bear incidental testimony to this fact. Perhaps the Church's metrical hymn-music is that branch of her song which is most directly and immediately borrowed from ancient Greece. We find the old Greek and Roman metres freely employed in the ancient Christian hymns; and doubtless the music to which they were first allied, bore no very remote resemblance to that used in the heathen temples.

¹ Dr. Burney says that "the only Jews now on the globe who have a regular musical establishment in their Synagogue, are the Germans, who sing in parts: and these preserve some old melodies or chants which are thought to be very ancient."

Padre Martini collected a great number of the Hebrew chants, which are sung in the different synagogues throughout Europe. Dr. Burney has inserted several of these in his *History of Music*. But, with a single exception, they show not even the remotest

affinity to the Gregorian system of melody; nor, in the sequence of their notes, any possible observance of the ecclesiastical modes or scales.

There is, however, one exception. One single melody bears so strange a resemblance (probably purely accidental) to a Church Chant, that it is worth preserving. Transcribed into modern notation, and written in a chant form, with simple harmony, it is as follows:—

Melody to the Title of the LI Psalm, or Lannatzeach, as sung by the Spanish Jews.

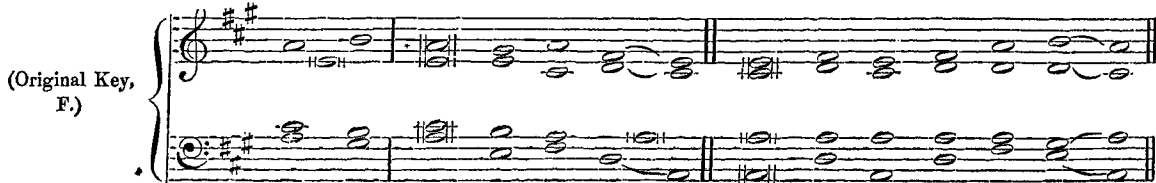

² An influence which was eventually exercised towards very pernicious ends.

Metrical hymns appear to have been first used to any extent by heretics, for the promulgation of their tenets; and then by the Church, with the view of counteracting heretical teaching, and popularizing the true faith. St. Chrysostom's attempts to overcome attractive Arian hymn-singing at Constantinople with more attractive orthodox hymn-singing, are well known. Socrates tells us of "the melodious concert and sweet harmony in the night season;" of the "silver candlesticks, after the manner of crosses, devised for the bearing of the tapers and wax candles," presented to the good Bishop by "*Eudoxia*, the Empress," and used by him to add beauty to his choral processions.

It was shortly before this period that St. Ambrose had introduced into the West the system of Hymn-singing and Antiphonal Psalm-chanting. He is said to have learnt it at Antioch, and to have brought his melodies thence. Responsive singing seems never to have been practised in the West till his time: and the circumstances attendant upon its introduction,—for the purpose of relieving his people in their nightly services during the Arian Persecution,—form an interesting episode in Church History. St. Augustine's touching account of the effect produced upon himself by the psalms and hymns in St. Ambrose's Church in Milan, has often been quoted, and is well known. And it is in reference to the period just referred to, that he informs us [Conf. ix. 7], that "it was then ordained that the Psalms and Hymns should be sung 'secundum morem Orientalium partium;'" and that from Milan this Eastern antiphonal system spread throughout all parts of Western Christendom.

It is very difficult to ascertain accurately (and this is not the place to discuss) the exact nature and extent of the influence exerted by St. Ambrose over the Music of the Church in the West. That his influence was very considerable is shown by the fact of the extended use of the term "Cantus Ambrosianus" for Church song generally. Possibly this wide use of the term may account for the title given to the old melody of the "*Te Deum*," which—certainly, at least, in the form in which it has come down to us—cannot be of the extremely early date which its name would appear to imply.

But the name of St. Ambrose, as a musical reformer, was eclipsed by that of his illustrious successor, St. Gregory, who flourished about 200 years after. As Church Song was all "Ambrosian" before his time, so has it, since, been all "Gregorian." The ecclesiastical modes, or scales, were finally settled by him; until the time when Church music broke through its trammels, rejected the confined use of modes and systems essentially imperfect, and, under the fostering influence of a truer science, developed its hidden and exhaustless resources.

Without entering into any detail respecting the ancient Church scales, it may not be out of place to state thus much:—

I. The four scales admitted by St. Ambrose, called the Dorian, Phrygian, Lydian, Mixo-Lydian (modifications of the ancient Greek scales so named), were simply, in modern language, our respective scales of D, E, F, G, *without any accidentals*; the melodies written in each ranging only from the key-note to its octave, and ending properly on the key-note, thence called the "*final*."¹

Now each particular scale had its own reciting note (or "dominant"), generally a *fifth* above the final. Thus (had there been no exception) we should have had:—

The respective "finals" of the 4 scales	{	D E F G	}	and their corresponding "dominants," or notes for recitation	{	A B C D
---	---	------------------	---	--	---	------------------

But there was *one* exception. For some reason or other, B was not approved of as a Recitation note; and hence, in the second scale, C was substituted for it.

II. To each of these four scales, St. Gregory added a subordinate, or attendant, scale—just as, in the ancient Greek system, each "principal" mode had two subsidiary, or "plagal," modes; the one below (*ὑπο*) it, and the other above (*ὑπερ*) it—beginning four notes *below* it, and therefore characterized by the prefix *ὑπο* (*hypo*, or *under*).

Thus, to St. Ambrose's 1st (or Dorian) mode, St. Gregory added a *Hypo-Dorian*.

To his 2nd (or Phrygian), St. Gregory added a *Hypo-Phrygian*.

¹ It is not meant that all the chants or melodies in each mode do really end on the "final;" but that this is the note, in the scale, on which a melody, which came to a full close, would naturally terminate.

To his 3rd (or Lydian), St. Gregory added a *Hypo-Lydian*.

„ 4th (or Mixo-Lydian) „ „ *Hypo-Mixo-Lydian*.

So that the number of the scales, instead of four, became eight.

Each added scale is essentially the same as its corresponding “principal” scale; the “final” (or key-note, so to speak) of each being the same. Thus, D (for instance) is the proper final note for melodies, whether in the Dorian or Hypo-Dorian mode.

The only points of difference between St. Gregory’s added, and St. Ambrose’s original, scales are these:—

1. That each added scale lies a *fourth below* its original.

Thus, while the melodies in the four primary scales lie respectively between D, E, F, G, and their octaves; the melodies in the “plagal,” or secondary, scales lie between A, B, C, D, and their octaves.

2. And next, that the recitation notes (or dominants) of the two sets of scales are different; those of the added scales being respectively F, A, A, C.

Thus the eight scales as finally settled by St. Gregory are as follows:—

<i>Name.</i>	Range of 8 notes beginning from	“Final” (or Key note)	“Dominant” (or Reciting note)
1st. Dorian	D	D	A
2nd. Hypo-Dorian	A	D	F
3rd. Phrygian	E	E	C
4th. Hypo-Phrygian	B	E	A
5th. Lydian	F	F	C
6th. Hypo-Lydian	C	F	A
7th. Mixolydian	G	G	D
8th. Hypo-Mixolydian	D	G	C

In strict Gregorian song the notes were all of uniform length; and the only accidental ever allowed was the B flat.

It was necessarily by slow degrees that Ritual song assumed its full proportions, and the Divine Service clothed itself, in all its parts, with suitable musical dress.

Monotonic Recitative forms the basis of “plain song.” In fact, in early times it would appear that, except in the Hymns, Church music was exceedingly simple in character. St. Augustine tells us that St. Athanasius strongly discouraged the use of much inflexion of voice and change of note in the saying of the Divine Office. He would even have the *Psalms* sung almost in monotone: a practice, however, with which St. Augustine’s keen musical susceptibilities could not bring him wholly to sympathize.

From the simple monotone, the other portions of the plain song little by little developed themselves. The bare musical stem becomes ever and anon foliate: its monotony is relieved with inflexions, recurring according to fixed rule. Then it buds and blossoms, and flowers into melodies of endless shape.

When the musical service of the Western Church became in a measure fixed, it consisted mainly of the four following divisions:—

1. There was, *first*, the song for the prayers, the “Cantus Collectarum,” which was plain monotone¹.

2. *Secondly*, there was the song for the Scripture Lectures, the “Cantus Prophetarum,” “Epistolarum,” “Evangelii,” which admitted certain inflexions. These inflexions were for the most part of a fixed character, and consisted (ordinarily) in dropping the voice,—*a.* at each comma or colon, a *minor third* (“*accentus medius*”); *β.* at each full-stop, a *perfect fifth* (“*accentus gravis*”)².

¹ In the Roman use, the monotone was unbroken; but in the Sarum use, there was generally the fall of a perfect fifth (entitled the “grave accent”) on the last syllable before the Amen.

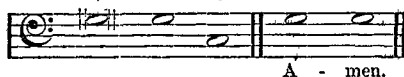

² But in case the clause ended with a monosyllable, the following variations took place:—

- a. The “*accentus medius*” gave way to

the “*accentus moderatus*,” or “*interrogativus*,”

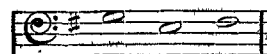

- β. And the “*accentus gravis*” to the

“*accentus acutus*,”

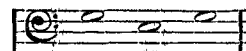

It is noticeable that while the Church of England (following the lead of Merbecke) has retained the use of the “mediate” and

The same rule was followed in intoning the versicles and responses, the versicle and response *together* being regarded as a complete sentence; the close of the former requiring the "mediate," the close of the latter the "grave" accent¹.

3. The *third* division embraces the Psalm-chants. These seem originally to have followed the rule of the "Cantus Prophetarum;" to have consisted of plain monotone, relieved only by one of the "accents" at the close of each verse. In course of time the middle, as well as the end of the verse, came to be inflected. The inflexions became more varied and elaborate; the result being a whole succession of distinct melodies, or chants, following the laws of the several ecclesiastical modes.

4. As the third division admitted of far greater licence than either of the two former (ultimately, of very considerable melodic latitude), so was the *fourth* division more free and unrestrained than all. This embraces the music for the Hymns, metrical or prose; for Prefaces, Antiphons, and the like. From these any continuous recitation note disappears altogether, and an unrestricted melody is the result.

Church Song has passed through many vicissitudes; becoming at times viciously ornate, debased, and emasculate. So long as the people took part in the service, the music was necessarily kept very simple. When they ceased to participate, and the service was performed for them, the once simple inflexions and melodies became expanded and developed,—ten, twenty, or more notes being constantly given to a syllable; and the plain song became the very reverse of *plain*, and for all purposes of edification practically useless.

Many protests were from time to time issued; but it was not until the period of the Council of Trent, in the sixteenth century, that really effectual and energetic measures were taken to arrest the growing evil. At that time the laborious task of examining and revising the Plain Song of the Western Church was entrusted to Palestrina (who took for his coadjutor the indefatigable Guidetti) by the musical commissioners (one of them the great St. Carlo Borromeo) appointed by the Council of Trent.

But twenty years before Palestrina had set about his toilsome work, a similar movement had been initiated in this country, in connexion with our revised Office-books.

When the great remodelling of our English Services took place, earlier in the same century; when the energetic and successful attempt was made to render them once more suitable, not only for private and claustral, but for public congregational use, and at the same time to disencumber them of any novelties in doctrine or practice which in the course of ages had fastened round them; when the old Mattins, Lauds, and Prime of the Sarum Breviary were translated into the vernacular, compressed, and recast into the now familiar form of our English "Mattins," or "Morning Prayer," and the Vespers and Compline of our "Evening Prayer," or "Evensong;" the question of the *music* for these rearranged offices forced itself upon the notice of our Church rulers. And it is most interesting to note, how the same wise conservative spirit, which had guided the changes in the *words*, manifested itself in the corresponding changes in the *music* with which those words were to be allied.

Radical alteration in either department there was none, simplification being the main object. And thus, in the province of Church Music, the great aim was not to discard, but to *utilize* the ancient plain song, to adapt it to the translated offices, to restore it to something more of its primitive "plainness," to rid it of its modern corruptions, its wearisome "*neumas*," and ornaments and flourishes; so that the Priest's part, on the one hand, might be intelligible and distinct, and not veiled in a dense cloud of unmeaning notes, and the people's part, on the other, so easy and straightforward, as to render their restored participation in the public worship of the Sanctuary at once practicable and pleasurable.

It has been hastily imagined by some in modern days that our great liturgical revisionists of the sixteenth century designed to abolish the immemorial custom of the Church of God, alike in Jewish and Christian times, of saying the Divine Service in some form of solemn musical recitative, and to introduce the unheard-of custom of adopting the ordinary colloquial tone of voice. But such a serious and uncatholic innovation never appears to have entered into their heads.

The most that can be said of our English Post-Reformation rule on this subject is, that in case of real incapacity on the part of the priest, or other sufficient cause, the ordinary tone of voice *may* be employed; but this only as an exceptional alternative. The *rule* itself remains unchanged, the same as of old.

"moderate" accents, she seems practically to have parted with the "grave" and the "acute."

¹ Or their substitutes, in case of a monosyllabic termination. See the preceding note.

The Rubrical directions, "read," "say," "sing," expressed in the old technical language, are substantially what they were before. The first of these words, "legere," was the most general and comprehensive; merely expressing recitation from a book, without defining the "*modus legendi*," or stating whether the recitation was to be plain or inflected. The usual *modes* of recitation are expressed in the words "say" and "sing;" the former ("dicere") pointing to the simpler, the latter ("*cantare*") to the more ornate mode. Thus the old "legere" might signify (and often did) ornate singing; and it might signify (and often did) plain monotone; and it is observable that the words "say" and "sing" are often employed interchangeably in the old rubrics, when their specific distinctions do not come into prominence¹.

Now the same holds good in our present Book. For instance, in one place we find a rubric ordering that the Athanasian Creed shall be "read here." Now, the point of this rubric being the particular *position* in which the Creed shall be recited, and not the particular *mode* of its recitation, the general term "legere" is employed. The "*modus legendi*" is determined by other rubrics, which prescribe that it may be "either said, or sung;" i. e., which allow of *both* modes of choral recitation, either the plain, or the ornate; either the simple monotone, or the regular chant.

The same thing occurs in another rubric, which (like the former), dealing with the *position*, not the mode, orders the "Venite" to be "read" in a certain place. Now the general term "read" in this instance is obviously equivalent with the word "sing;" the Church of England always contemplating that the Psalms shall be not said on the monotone, but sung to regular chants².

The two works which directly illustrate the mind of the English Church as to the musical rendering of her reformed Service are, 1st, the *Litany* published by Cranmer with its musical notation (the first instalment of our Book of Common Prayer); and, 2ndly, the more important work containing the musical notation of all the *remainder* of that Book, edited (plainly under the Archbishop's supervision) by John Merbecke, and published "cum privilegio" in the same year with the first Prayer Book of Edward VI.

A word or two may be said respecting both these publications.

1. The Litany was published in 1544 in a work entitled "An exhortation unto praier thought mete by the King's Majestie and his clergie, to be read &c. Also a Litany with suffrages to be said or sung." Now this Litany was set to the beautiful and simple old Litany chant still used in most of our Cathedrals and Parish Churches where the service is chorally rendered. It was republished by Grafton, with harmonies in five parts, a month after its first appearance. Some twenty years afterwards it was again harmonized by Tallis; and it has been harmonized and set in different forms by many of our English Church musicians.

2. The other publication was entitled "The Booke of Common Praier noted," wherein "is conteyned so much of the Order of Common Praier as is to be song in Churches." Like the Prayer Book itself, it contains nothing absolutely *new*: the old English Service Music being simplified and adapted to our revised and translated Offices. The adjustment of the musical notation is as follows:—

i. For the Prayers, the old "Cantus Collectarum," or simple monotone, is used³.

ii. For the Versicles and Responses, the old inflected "Cantus Prophetarum"⁴.

iii: In the Scripture Lections, however, it seems manifest that it was not in contemplation to retain the use of this last-mentioned inflected Song, which of old appertained to them. In the Pre-Reformation Service-books the "Capitula" and the Lections were generally very short; the latter being moreover broken and interrupted by Antiphons. Here, inflected musical Recitative might not be inappropriate. But to sing through a long lesson from the English Bible in the same artificial method, would be plainly wearisome, if not somewhat grotesque⁵. Hence our rubric ordered that "in such places where they do sing, then shall the lesson be sung in a *plain* tune, after the manner of distinct reading; and likewise the Epistle and Gospel."

¹ "How depe and inwarde comforte shoulde yt be to you to syng and rede and say thys holy seruyce." Oure Ladyes Myroure, f. v.

² "The Psalter, or Psalms of David, pointed as they are to be sung (or said) in Churches." The Psalter, we see, is specially pointed for singing: the pointing itself plainly expressing the mind and wish of the Church. The "say" only gives a permissible alternative where there is no choir.

³ In two instances (but only two) Merbecke has adopted a special peculiarity of the Sarum (as distinguished from the Roman) Rite, in the employment of the *grave accent* (see p. lviii) on the last syllable of the collect preceding the "Amen."

⁴ See also p. lviii.

⁵ See an instance of this method described at p. 96, note.

Now here the emphatic word appears to be "*plain*," as opposed to "inflected;" and the object of the rubric, to recommend the substitution of the "*Cantus Collectarum*," or monotone, for the Lessons, Epistle, and Gospel, in place of the ancient "*Cantus Prophetarum*." It is needless to point out, by the way, in the face of a rubric which defines the mode in which even the *lessons* are to be "sung," how little idea there was on the part of our Liturgical Revisers of interfering generally with the ancient musical performance of Divine Service.

It may not be out of place here to remark, that the above rubric which ordered the "*plain tune*" for the lessons, was, after the lapse of above a century, ultimately withdrawn. The Puritans strongly urged its withdrawal at the Savoy Conference, prior to the last Review in 1661. Our Divines at first refused to yield, alleging that the objections urged against the use of Monotone for Holy Scripture were groundless. However, they gave way at last: and it is, perhaps, happy that they did. For, while in the case of solemn public addresses to Almighty God, the grave, devout, unsecular, ecclesiastical recitative is alone appropriate; in the case of addresses to *man*, even though they are lessons of Holy Scripture, which are read for purposes of *instruction*, a freer and less formal mode of utterance seems alike suitable and desirable.

iv. The *Te Deum* is set to the ancient Ambrosian melody, simplified and adapted to the English words from the version given in the Sarum Breviary.

v. The other Canticles and the Psalms are assigned to the old Gregorian chants. The Book does not actually contain the Psalter with its chants (just as it does not contain the Litany with its music, which had been already published). A simple Gregorian melody (8th tone, 1st ending) is given for the "Venite;" after which is added, "and so forth with the rest of the Psalms as they are appointed." The primary object of this was, probably, to keep the Book in a reasonably small compass, and avoid the great additional expense of printing a musical notation for each verse of the entire Psalter. But partly, no doubt, it was the uncertainty then felt (and even to the present day, to some extent experienced) as to the best mode of selecting and adapting the old chants to English words, which caused the editors instinctively to shrink from the responsibility of so soon determining these delicate points, and to prefer leaving it to the different Choirs and Precentors to make experiments, and adapt and select according to their own judgment. There is no proof that it was intended to fasten this particular book upon the English Church. It was probably of a tentative and experimental character. It was put forth as a companion to our Revised Service-book, as a practical explanation of its musical rubrics, and as also furnishing examples and specimens of the *way* in which the framers of our vernacular offices originally contemplated that they should be allied with the old Latin Ritual Song.

vi. In the music for the Hallelujah ("The Lord's Name be praised"), for the Lord's Prayer in the Post-Communion, and for the Kyrie (the melody of the latter borrowed from the Sarum "*Missa pro Defunctis*"), we find merely the old Sarum plain-song reproduced in simplified form.

vii. The Nicene Creed, Gloria in Excelsis, and offertory sentences appear, from the structure of the music, to be all set to simplified forms of ancient Gregorian melodies. But their immediate source has not yet been clearly ascertained.

From what has been said it will incidentally appear, 1st, how fully determined were our sixteenth century Revisionists that the Offices in their new form should not lose their old choral and musical character; and thus that Divine Service should still continue what it had ever theoretically been, a "Service of Song." And, 2nd, how earnestly anxious they were that the music should be of a plain and simple character, so that it might be a real aid in the great object they had before them, that of restoring to the people their long-suspended right of due and intelligent participation in the public worship of the Sanctuary.

In illustration of these points, Cranmer's letter to Henry VIII., dated Oct. 7, 1544, is interesting; and although it is printed entire at p. xxii, it is necessary again to refer to it in connexion with our present subject. After speaking of the English Litany already published with musical notation; and of certain other Litanies, or "Processions," which he had been preparing, and which he requests the King to cause to be set to music, on the ground that "if some devout and solemn note be made thereunto," "it will much stir the hearts of all men to devotion;" he proceeds to offer his opinion as to the kind of music suitable for these Litanies, as also for other parts of the Service:

"In mine opinion the Song that shall be made thereunto would not be full of notes, but as near as may be for every syllable a note; as be, in the *Matins and Evensong*, 'Venite,' the Hymns 'Te Deum,' 'Benedictus,' 'Magnificat,' 'Nunc Dimittis,' and all the Psalms and Versicles; and, in the *Mass*, 'Gloria in excelsis,' 'Gloria Patri,' the Creed, the Preface, the 'Pater noster,' and some of

the 'Sanctus' and 'Agnus.' As concerning the 'Salve, festa dies,' the Latin note, as I think, is sober and distinct enough; wherefore I have travailed to make the verses in English, and have put the Latin note unto the same. Nevertheless, they that be cunning in singing can make a much more solemn note thereto. I made them only for a proof, to see how English would do in song."

The last portion of this letter introduces a subject on which it is necessary to add a few words, viz., the use of Metrical Hymns in public worship.

Cranmer himself was most anxious to have retained the use of them, and with that view set about translating the Breviary Hymns. But he was so dissatisfied with his attempts, that eventually he gave up the idea. This loss was a serious one, and soon made itself experienced. Fervent Christian feeling must find means of expression; and if not provided with a legitimate outlet, such as the Hymns of the Church were intended to furnish, will vent itself in ways irregular, and, perhaps, in unorthodox language.

It is difficult to ascertain the exact time when the practice of popular Hymn and metrical Psalm singing established itself in connexion with our revised ritual, though independently of its direct authority. Such singing was in use very early in Elizabeth's reign, having doubtless been borrowed from the Protestants abroad. For the purpose of giving a quasi-official sanction to a custom which it would have been very unwise to repress, (and thus, through a sort of bye-law, to supply a practical want in our authorized public Ritual,) it was ordained, by a Royal Injunction in the year 1559, that, while there was to be "a modest and distinct *song* so used in all parts of the Common Prayers in the Church that the same might be understood as if it were read without singing;" (in other words, while the old traditional plain-song, in its simplified form, is to be employed throughout the whole of the service; yet,) "for the comfort of such as delight in musick it may be permitted, that in the beginning or at the end of the Common Prayer, either at morning or evening, there may be sung an hymn or such like song to the praise of Almighty God, in the best sort of melody and musick that may be conveniently devised; having respect that the sentence [i. e. sense] of the hymn may be understood and perceived."

To this Injunction of Queen Elizabeth we owe our modern Anthem; on which it is necessary to add a few words.

The term itself is merely an Anglicized synonym of the word Antiphon. Its old spelling was *Antem*, *Anteme*, or *Antempne*¹. Its origin is the Greek word *ἀντίφωνον*, or rather *ἀντίφωνα* (*antiphona*: neut. plur.), which is the old ecclesiastical term. From *antiphona* comes the Italian and Spanish *antifona*, as well as the old English form *antephne*, and the Anglo-Saxon *antefn*. Now, just as the Anglo-Saxon word *stefn* (the end, or prow, of a ship) became *stem* in English, so did *Antefn* become *Antem*. The further change of the initial *ant* into *anth* is merely parallel with the corresponding change of the Old English *te* and *tat* into *thee* and *that*².

From the fact of Barrow in one of his sermons spelling the word "Anthem," Dr. Johnson and others have hastily inferred that its true origin is to be traced in *ἀντι ὕμνος* or *ἄνθυμνος* (*anti-hymnus*, or *anthymnus*), which would give it the meaning of a responsive hymn. And it is by no means improbable that the accidental similarity in *sound* between the final syllable of "Anthem" and the word "hymn," coupled with the fact of the intelligible, and in a measure correct, meaning which this plausible derivation would seem to afford, has not been without its influence in determining the popular sense of the word itself. But there is not a vestige of authority for this latter derivation, nor shadow of doubt that *φωνή* and not *ὑμνος* is the root out of which "Anthem" grows.

In its earliest form, the Anthem, or Antiphon, seems to have been a single verse out of any Psalm repeated after the recitation of the Psalm (and, in later times, *before* its recitation also) with a view of fixing the *key-note*, so to speak, of the Psalm; of bringing into prominence, and fastening attention upon, some special idea contained within it. In course of time the Antiphons came to be selected, not exclusively from the particular Psalms to which they were affixed. Appropriate passages of Scripture from any part, even short uninspired sentences in prose or verse, came to be similarly applied. From the fact of the Antiphon giving the key-note or leading idea of the Psalm to which it was attached, we find the word Anthem frequently used for the text of a sermon³.

¹ See p. lvi, and "the Myrroure of our Lady," fol. lxxxix.

² For a discussion on the derivation and use of the word Anthem, see Notes and Queries, 2nd Series, xi. 457. 491; xii. 90. 151.

³ It may be remarked, that as the idea of Responsive Music lies at the bottom of Antiphon, or Anthem (whence we find old writers speaking of the Psalms as sung *Anthem-wise*, i. e. respon-

sively), so, in the actual and varied use of the word, we find, sometimes the Responsive, and sometimes the Musical, element coming into prominence: occasionally, one or the other element entirely disappearing. In the text of a sermon, for instance, there is nothing *musical*. In a modern Anthem, there is nothing necessarily *responsive*.

When the use of a "Hymn, or such like song," was authoritatively permitted at the beginning or end of Common Prayer—not only with a view of adding dignity and interest to the worship of Almighty God, and rendering the Service of Praise more worthy of Him to whom it was offered; but with the twofold secondary end also (1) of "comforting" musical people by allowing the strains of the Sanctuary a greater freedom of development than the mere chant and plain-song intonations admitted, and thus (2) of encouraging amongst all classes the study and practice of music—our Church composers, in casting about for suitable words, seem first to have had recourse to the old Antiphons, many of which they set to music. Other similar brief and characteristic passages of Holy Scripture, Prayers, Hymns, and the like, were speedily selected for the same purpose; but the name "Anthems," whether they happened to have been used as Antiphons or not, equally attached itself to all.

Many have endeavoured to discover some definite ritual significance in the word itself, and in the position occupied by the Anthem in our Service, to account for its name. It has been regarded as the intentional "residuum" of the Antiphons of the old Service-books. But such theories, though interesting, are unsubstantial. It is all but certain, that it was through a loose, accidental, popular application of an old term, the strict meaning of which was not a matter of much concern, rather than through any deliberate conviction of the modern Anthem being, practically or theoretically, identical with, or a legitimate successor and representative of the old Antiphon, that the name Anthem finally allied itself with that class of musical compositions or Sacred Motets which now form a recognized adjunct to our English Service¹. It may be added that, in country parishes, where a trained choir could not be obtained, a metrical Psalm would be sung in the place of the Anthem, and fall under the same general designation.

The actual period of the introduction of the term in its familiar modern and popular sense, to denote a piece of sacred music for the use of the Church, may perhaps be approximately illustrated by a comparison of the titles of two successive editions of a very important musical work. Within the year after the publication of Queen Elizabeth's Injunction giving permission for the use of a "Hymn, or such like song," John Day printed his great choral work entitled, "Certain notes set forthe in 4 & 5 parts, to be sung at the Morning, Communion, & Evening Prayer, very necessary for the Church of Xt to be frequented & used. And unto them be added divers godly Prayers & Psalmes in the like form to the Honour and Praise of God." Five years later, this fine work, to which Tallis with other famous Church writers contributed, was reprinted, though with a somewhat different title: "Morning & Evening Prayer & Communion set forth in 4 parts, to be sung in Churches, both for men & children, with divers other godly Prayers & *Anthems* of sundry men's doyinges." In the second edition we thus have the word "*Anthems*" used, where in the first edition "*Psalmes*" had been employed.

An illustration of the early actual use of the Anthem, in its modern English sense, is afforded by Strype, in his description of the Lent Services which took place in the Chapel Royal, within a year of the time when the permissive Injunction for the use of "a Hymn, or such like song," was published, at the beginning of Elizabeth's reign.

"The same day" (he writes, i.e. Midlent Sunday, March 24, 1560), "in the afternoon, Bp. Barlow, one of King Edward's Bishops, now Bishop of Chichester, preached in his Habit before the Queen. His sermon ended at five of the clock: and, presently after, her Chapel went to Evening Song. The Cross as before standing on the Altar; and two Candlesticks, and two Tapers burning in them. And, Service concluded, a good *Anthem* was sung." [See also Machyn's Diary, 1560.]

Thus the place of the Anthem became practically settled after the third Collect, with which Morning and Evening Prayer at that time concluded; although it was not till above 100 years after this period that there was any *rubrical* recognition of the Anthem, or direction concerning the time of its performance. When, however, at the last Review, in 1661, the concluding prayers were added, the Anthem was not removed to the *end* of the Service, as before, but was still allowed to retain its old traditional place after the third Collect. And it was with a view of fixing this position that the Rubric was inserted, "In Choirs and places where they sing, here followeth the Anthem."

But although this is the only place where the introduction of a "Hymn, or such like song," or "Anthem," is definitely authorized, yet custom has sanctioned a much freer interpretation of the

¹ It will also be observed, that the two English words—really identical, and coming from the same root—Antiphon and Anthem, have finally parted company; the former retaining its ancient ritual, the latter acquiring a modern musical meaning.

Rubric than its words actually convey. Practical need has asserted and substantiated its claim. The Rubric, or rather the original Injunction on which the Rubric was based, has shown itself conveniently expansive and elastic, and the word "Anthem" proved a pregnant and germinant one, covering at once the Hymn, the Introit, and the Anthem proper. The truth is, however, that it is to custom and necessity, not to Rubrics or Injunctions, that we owe the general introduction of Music, as distinct from Plain song, into our Revised Offices. Custom drew forth the Injunction of Queen Elizabeth; the Injunction subsequently gave rise to the Rubric. But as Music originally found its way into our Reformed Service, independently of written authority, so, independently of written authority, does it continue. For the very necessity which received formal recognition in the Anthem-Rubric, refuses to be satisfied with or limited by the strict terms of that Rubric. The Anthem, in some shape or other, was a *fact* before ever any written authority called it into legal existence; and in like manner, Hymn-singing, over and above the Anthem, has been, and is, and will be, an actual *fact*, notwithstanding its apparent want of formal rubrical sanction.

The result of all is, that while "*the Anthem*" still retains its place, as a special offering to God of the firstfruits of sacred musical skill and science, "in choirs and places" where such an offering is possible, the additional introduction elsewhere of suitable Hymns, whether in the Eucharistic or other Offices, as aids and reliefs to the Services, is not only not thereby excluded, but practically and subordinately and implicitly sanctioned.

This Section may be concluded with some practical rules on the subject of which it has treated.

1. Although, as we have seen, there was no deliberate intention, on the part of our Liturgical Revisers, that the old Antiphon should be reproduced, or find an exact counterpart in the modern Anthem; still, on the other hand, it is most desirable that the Anthem should practically—by its appropriate character, by its responding accordantly to the Service of the day, bringing out and emphasizing its special theme—vindicate its right to the title it has obtained, and prove itself a legitimate successor and representative of the Antiphon¹. Anthems or Hymns may thus become invaluable auxiliaries; imparting a freedom and variety to our Service which it would not otherwise possess, and rendering it susceptible of easy adaptation to the ever-changing phases of the Church's year. If the "Hymn, or such like song," does *not* possess any of this "Antiphonal" character, if it is regarded merely in the light of so much music interpolated into the Office by way of relief, it becomes simply an element of disintegration, splitting up the Service into several isolated fragments, instead of imparting a unity and consistency and character to the whole. Hence the need of due and reverent care in the selection of the Anthems and Hymns. Judiciously chosen, they may not only give new beauty and meaning to our Services, but may also prove most useful and delightful means of propagating and popularizing Church doctrine, and promoting the growth of genuine and healthy Church feeling.

2. As regards the position of the Hymns. The Elizabethan Injunction specifies the "beginning or end of Common Prayer;" and the Rubric says, "after the third Collect." So that we have three available places for "Hymns, or such like songs." The Hymn at the *beginning* of Common Prayer, although desirable on great Festivals, as a kind of Antiphon fixing the key-note of the whole succeeding Service, is somewhat inconsistent with the general penitential character of the Introduction to our Mattins and Evensong, and should not, therefore, be ordinarily employed². During the Eucharistic Office, the singing of Hymns, independently of the Nicene Creed, and the great Eucharistic Hymn "*Gloria in Excelsis*," is most desirable. There may be (1) an introductory "*Introit*;" (2) a Hymn, or (as the alternative provided in Edward's First Prayer Book) the "*Agnus Dei*;" after the Prayer of Consecration; and (3) a Hymn, or (as a very suitable alternative) the "*Nunc Dimittis*," when the Service is over, and the remains of the Consecrated Elements are being reverently consumed. In the

¹ It should, perhaps, be remarked, that there still remain in the Prayer Book a few instances of the word Anthem retaining its old meaning. For example, the Invitatory Psalm, "*Venite exultemus*," is regarded in some sort as a fixed Antiphon before the Psalms for the day, and is in this sense called an Anthem; the Rubric enjoining its constant use, "except on Easter-day, upon which *another* Anthem is appointed." The word is also used in its old sense in the following passage from the Introduction, "Concerning the Service of the Church:"—"For this cause be cut off *Anthems*, Responds, Invitatories, and such like things

as did break the continual course of the reading of the Scripture."

The "O Saviour of the world," after the Psalm in the "Visitation of the Sick," is strictly an Antiphon.

² See, however, a note on the invitatory character of the sentences, at p. 1.

³ "In the Communion time the Clerks shall sing—
"O Lamb of God, that takest away the sins of the world:
have mercy upon us.
"O Lamb of God, &c., grant us Thy peace."

Office for Holy Matrimony, the Order for the Burial of the Dead, and other occasional Offices, Hymns may be often most appropriately and happily introduced.

3. With regard to the exact nature of the music to be employed in the Psalms, Hymns, Canticles, Anthems, &c., it would be most unwise, even if possible, to lay down any strict rules. While it would be a great error to discard many of the ancient Hymn-tunes and Psalm-chants of the Church, it would be a no less serious error to keep exclusively to them. The Church must bring forth from her treasure-house "things new and old;" not only the severe (and to some ears uncouth) unisonous strains of by-gone times, but also the rich, full harmonies of modern days. All must be freely, fearlessly employed, according as taste, or special circumstances, or choral capability may dictate. Experiments must be made, mistakes perhaps braved; for many questions as to the best practical methods of linking together the "sphere-born, harmonious sisters, Voice and Verse" in the Service of the Sanctuary remain as yet undecided. Hasty dogmatism, and intolerant exclusiveness, in reference to the accessories of Divine Worship, are much to be deprecated, for in all matters of external apparatus the Church of England has yet much to learn. In putting forth the full strength of our Prayer Book, and developing its inward powers and energies, there will be also gradually disclosed outward features and graces which seem new and strange from their having been so long latent. But it is certain that all the resources of the Church, external as well as internal, are needed for modern times; and that all appliances, musical, ritual, æsthetic, should be brought to bear on the services rendered to God by so cultivated an age, and set forth before men to win and help their souls. God having given all these outward aids—music, ritual, art—He *means* them to be employed for His glory, and in order to influence, and subdue, and attract mankind. As churches should be beautiful, and ritual beautiful, so music also should be beautiful; that it may be a more fitting offering to Him, and better calculated to impress, soften, humanize, and win. None of these Divinely-granted helps may be contemptuously laid aside. All should be reverently, humbly, piously used; used for God, not for self; used in full and fearless confidence that it is His own blessed *will* that they should be used; used with the single eye to the glory of God, and the spiritual welfare of His people.

SECTION III.

THE ACCESSORIES OF DIVINE SERVICE.

DIVINE SERVICE being, as the term implies, the act of Worship rendered to God, it follows from the consideration of His Majesty that the place where it is offered, and the persons engaged in conducting it, should be furnished with whatever is suitable to denote its reverent dignity.

The practice of the Jewish Church in this respect, based as it was on a Divine command which prescribed even its minutest details, proves that such accessories are not in their own nature unacceptable to God, or inconsistent with the claims of a Spiritual Being to the homage of His rational creatures.

Further, the sanction given by our Lord Jesus Christ and His Apostles to the services of the Temple and the Synagogue, and the application made of the Jewish Ritual by St. Paul in his Epistle to the Hebrews, furnish indisputable authority for incorporating similar symbolic uses with Christianity, in order that it may present itself to mankind in a not less attractive form than the Religious System which it was designed to complete, but did in the end supersede.

That such a Christian adaptation of other existing Religious Ritual Customs was considered to be right and desirable, is evidenced by the fact that the Christian Church, from its earliest days downwards, has every where exhibited, though in varying degrees, this combination of Symbolical Ritualism with the highest spiritual worship; and thus has practically enunciated a law—that Divine Service is to be accompanied with external accessories.

The RULE given by the Church of England in applying this principle is contained in the following general *Rubric*, which is placed in a prominent position at the beginning of the Prayer Book:—

"And here is to be noted, that such Ornaments of the Church, and of the Ministers thereof, at all Times of their Ministration, shall be retained, and be in use, as were in this Church of *England*, by the Authority of Parliament, in the Second Year of the Reign of King *Edward* the Sixth."

A Rubric substantially, though not quite verbally, identical with this, first appeared in the *Eliza-*

Elizabethan Prayer Book of 1559: the necessity for which arose out of the determination, on Queen Elizabeth's accession, to abandon the Latin Service-books, which had been restored in Queen Mary's reign, and to revert to the form of Divine Worship arranged in the Second Prayer Book of King Edward VI. [A.D. 1552], though with some revisions which made it more conformable to the First Reformed Prayer Book [A.D. 1549]. This change in the Services necessarily required some adaptation in the Accessories of Divine Worship; and as these had also undergone alterations during the period in which the Prayer Books of 1549 and 1552 were employed, it was requisite to adopt some standard by which to regulate them. The standard chosen was the use which prevailed "by the Authority of Parliament, in the Second Year of the Reign of King Edward the Sixth." The Rubric which declared this decision was also incorporated with the Elizabethan Act of Uniformity; it was retained in the very slightly revised Prayer Book of James I., and was re-enacted at the last revision in 1661. It will facilitate the comparison of these four directions, to place them in parallel columns, thus:—

<i>Prayer Book, 1559.</i>	<i>Statute 1 Eliz. c. 2, § 25, 1558-9.</i>	<i>Prayer Book, 1603-4.</i>	<i>Prayer Book, 1662.</i>
<p>"And here is to be noted, that the Minister at the time of the Communion, and at all other times in his Ministration, shall use such Ornaments in the Church as were in use by authority of Parliament in the second year of the reign of King Edward the Sixth, according to the Act of Parliament set in the beginning of this Book."</p>	<p>"Provided always, and be it enacted, that such Ornaments of the Church, and of the Ministers thereof, shall be retained and be in use, as was in this Church of England by authority of Parliament, in the second year of the reign of King Edward the Sixth, until other order shall be therein taken by the authority of the Queen's Majesty, with the advice of her Commissioners appointed and authorized under the Great Seal of England, for Causes Ecclesiastical, or of the Metropolitan of this Realm."</p>	<p>"And here is to be noted that the Minister at the time of the Communion, and at all other times in his Ministration, shall use such Ornaments in the Church, as were in use by authority of Parliament, in the second year of the reign of King Edward the Sixth, according to the Act of Parliament set in the beginning of this Book."</p>	<p>"And here is to be noted, that such Ornaments of the Church, and of the Ministers thereof at all times of their Ministration, shall be retained and be in use as were in this Church of England by the Authority of Parliament, in the second year of the reign of King Edward the Sixth¹."</p>

But it should be noticed that, though the first three of these directions furnished the primary and general Rule during the period from 1559 to 1662, there were issued contemporaneously other orders relating to the same subject: these occur (1) in the Elizabethan INJUNCTIONS of 1559; (2) in the Elizabethan ADVERTISEMENTS of 1564-5; (3) in the Jacobean CANONS of 1603-4; (4) in the Caroline CANONS of 1640. Of all these, however, it must be remembered that they were not designed to supersede the fuller direction given in the two Rubrics and in the Statute: but that the *First* were *explanatory* of the Rubric and Statute of 1559; the *Second*, *Third*, and *Fourth* were drawn out by the laxity of the times, which necessitated endeavours to secure something like a general and uniform decency in the conduct of Divine Worship, and in order to effect this, insisted only upon the fewest and simplest of the Acces-

¹ In Bishop Cosin's Durham Prayer Book the Rubric is altered from its previous to its present form in his handwriting. At the end of the alteration is a note (not intended for printing, but underscored with a dotted line), "These are the words of the Act itself. v. Supra." He also began to write a list, but gave over the task after writing the word "Surplice." Probably he thought that to specify them might peril the Rubric itself; though it is clear that his wish was to name them, for, in his "Particulars to

be considered, explained, and corrected, in the Book of Common Prayer," he appends this note to the Rubric:—"But what those ornaments of the Church and of the minister were, is not here specified, and they are so unknown to many, that by most they are neglected. Wherefore it were requisite that those ornaments, used in the second year of King Edward, should be here particularly named and set forth, that there might be no difference about them." [Works, Ang. Cath. Lib. vol. v. p. 507.]

series which were prescribed under the fuller Rule. But these *four* series of *special* ORDERS being sometimes cited as Directions advisedly contrariant to the *general* RULES, it is desirable to state somewhat more particularly their precise character and object.

1. The INJUNCTIONS of 1559. Such of these as related to the Accessories of the Services and Offices appointed in the Prayer Book of 1559 were demanded by the then existing condition of things. The Statute 1 Mary, Sess. 2, c. 2, A.D. 1553, had abolished the alterations made in the reign of Edward VI., and legally restored the Services (together with their Accessories) to the condition in which they were left "in the last year of Henry Eighth." The consequence of this was, that the Injunctions of 1547 (whether *then* or *previously* having the force of an Act of Parliament or not is here immaterial) ceased to be of any authority, at least so far as they at all affected the character of the Services: nor do they seem to have subsequently regained their authority; for the reviving Statute, 1 Eliz. c. 1, A.D. 1558, does not touch them, and the Elizabethan Act of Uniformity could, at most, only very indirectly refer to them when restoring the book of 1552, "with the order of service," subject, however, to "the alterations and additions" made by the statute of 1559. Probably indeed it was intended not to continue the Injunctions of 1547, whether they had lapsed or not, since the issuing of new Injunctions would furnish a more convenient method of altering the former ones, if requisite, than the mere publication of amendments. But however this may have been, the Marian period having legally reintroduced some of those practices which the Injunctions of 1547 had regarded as abuses, they could not be forbidden on the ground of being unlawful. The obvious plan therefore was to repeat the process of 1547, and thus define legally how much of the existing general custom was designed to be preserved, by distinctly specifying such particular items of it as were thought desirable to be abolished. This was done by the Elizabethan Injunctions, which were founded upon those of 1547, and were followed by certain "Interpretations and further Considerations;" and thus, (except such of them as did not deal at all with any old, or authorized some new, practice in regard to Ritual and Ceremonial matters,) they simply subtracted certain portions from the existing whole, and so enabled the Clergy and Laity of that day to know exactly which and how many of the Accessories of Divine Service then employed were to be regarded as coming within the terms of the Rubric and Statute—"in the Second Year of the Reign of King Edward the Sixth." Rather less was, however, abolished by the Injunctions of 1559 than by those of 1547—e. g. nothing was said about the *removal* of Images, though the second Injunction forbade to "set forth or extol the dignity of any images, robes, or miracles."

2. The ADVERTISEMENTS of 1564-5. The necessity for these sprang from the great and growing negligence of the anti-ritual party, and their opposition to the then existing law which regulated the Ritual and Ceremonial. To so great a height had this attained, that it provoked a letter of complaint from the Queen to Archbishop Parker, dated January 25, 1564-5, wherein Her Majesty said that—"We, to our no small grief and discomfort do hear, that . . . for lack of regard given thereto in due time, by such superior and principal officers as you are, being the Primate, and other the Bishops of your province, . . . there is crept and brought into the Church . . . an open and manifest disorder and offence to the godly wise and obedient persons, by diversity of opinions, and specially in the external, decent and lawful rites and ceremonies to be used in the Churches . . .:" and the Queen further declared that—"We . . . have certainly determined to have all such diversities, varieties, and novelties . . . as breed nothing but contention, offence, and breach of common charity, and are also against the laws, good usages, and ordinances of our realm, to be reformed and repressed and brought to one manner of uniformity through our whole realm and dominions. . . ." [Parker Correspondence, p. 224.]

In consequence of this Royal Letter the Archbishop directed the Bishop of London (Grindal), as Dean of the Province, to inform the other Bishops of the Queen's commands, and also to direct them "that they inviolably see the laws and ordinances already established to be without delay and colour executed in their particular jurisdictions." [Parker Correspondence, p. 229.] Moreover, the varieties complained of were to be stated in returns which were to be sent to the Archbishop by the end of February.

But it is not difficult to understand, what seems to have been the case, that it was no easy task to deal with the prevalent disorder, encouraged as it was by a not inconsiderable body of persons (including many Clergy and some Bishops) who had a violent dislike of the prescribed Ritual and Ceremonial. Nor is it surprising to find that the Bishops, in order to promote uniformity, contented themselves with insisting upon the observance of only such of the existing requirements as they thought necessary for the decent conduct of Divine Worship. This *minimum* requirement was embodied in the Advertisements which, about a month later, were submitted to the Queen for her approval, that so they might be issued

with the full force of Ecclesiastical Law; yet, anxious as Her Majesty was to stop irregularities, the requisite authorization was withheld; and when, after some delay, they were permitted to be published, their enforcement appears to have depended upon the general authority of the Ordinaries; nor is it at all clear that they afterwards obtained that Royal sanction which alone could have armed the Bishops with adequate powers to compel their observance. There does not appear to be any very precise information on the matter, but the little which is available seems to imply that the Queen (if not also some of her Council) was dissatisfied with so low a standard of conformity as the Bishops had set up; and also that there was an unwillingness to supersede the Rubric on Ornaments, and its corresponding clause in the Act of Uniformity, by *legalizing* what probably it was then hoped would be no more than a temporary step towards attaining a further compliance with the Ecclesiastical Law under more favourable circumstances.

3. The CANONS of 1603-4. The history of the thirty-eight years between the publication of the Elizabethan Advertisements and the accession of James I., is that of a continuous strife between the Ecclesiastical Authorities and the non-conforming party in the Church of England; the efforts of the latter being encouraged by the hope, or persuasion, that the new King's familiarity with Scottish practices might favourably incline him towards their Presbyterian prepossessions. The Hampton Court Conference, which was held within the first year of King James's reign, was an effort to convince them, and to remove, if possible, any reasonable ground of complaint; but its proceedings revealed the weakness of the objections, and terminated in a resolution that any changes ought to be in the direction, not of laxity, but of strictness; and so the few alterations which were made in the Book of Common Prayer were of the latter character, and served to bring out more distinctly some points of its Doctrine,—points, however, which were clearly implied in the Services.

But it was easier, no doubt, to make *Doctrine* more objective in the Formularies than to enforce discipline, especially in Ritual and Ceremonial matters which were peculiarly obnoxious to those of Presbyterian inclinations. The long acquiescence in a low standard of practice in these respects could hardly be other than fatal to any attempt to impose obedience to the larger legal requirements which still subsisted. So, being, as it was, necessary, in the loose and fragmentary condition of many of the then existing Ecclesiastical Ordinances, to provide some complete code of discipline, it was nevertheless impossible probably to do more than re-enforce those more limited Orders which could not be dispensed with, unless the Clergy and Churches in England were to assume a garb little, if at all, distinguishable from the Ministers and Temples of the foreign Reformed bodies or of the Presbyterian Community in Scotland.

Accordingly, in the Book of Canons "collected by Bishop Bancroft out of the Articles, Injunctions, and Synodical Acts passed and published in the reigns of King Edward the Sixth and Queen Elizabeth," and passed by "both Houses" of Convocation [Collier, E. H., ii. p. 687], all that was deemed *indispensable* was embodied, and in virtue of the King's Letters Patent, which ratified these Canons, became *Statutably* binding upon the Clergy, and *Ecclesiastically* obligatory upon the Laity.

4. The CANONS of 1640. During the last twenty years of King James's reign, and the first fourteen years of his successor, King Charles I., there was a gradual improvement in the externals of Divine Service, due in part, no doubt, to the Canons just remarked upon, but more probably to greater vigilance among the Ecclesiastical Authorities, and to an increasing desire for the restoration of what had fallen into desuetude, though it was still upheld by Ecclesiastical enactments. But the Puritan leaven was still working in the Church of England, and its fermenting power was increased by Civil proceedings with which it came in contact. The effect of this was that accusations, vaguer or more specific, became current, and presented serious obstacles to those loyal and well-affected Churchmen who were doing what they could to rescue the worship of the Church from the ill condition to which a long period of negligence had reduced it.

It was for the purpose of defending generally this reformation, and of sanctioning particularly some of its more prominent features, that the Convocation of 1640 agreed to a small code of seventeen new Canons: their design being thus distinctly proclaimed in the Letters Patent which were prefixed to them:—

"Forasmuch as We are given to understand, that many of Our subjects being misled against the Rites and Ceremonies now used in the Church of England, have lately taken offence at the same, upon an unjust supposal, that they are not only contrary to Our Laws, but also introductive unto Popish Superstitions, whereas it well appeareth unto Us, upon mature consideration, that the said Rites and

Ceremonies, which are now so much quarreled at, were not onely approved of, and used by those learned and godly Divines, to whom, at the time of Reformation under King Edward the Sixth, the compiling of the Book of Common Prayer was committed (divers of whom suffered Martyrdom in Queen Maries days), but also again taken up by this whole Church under Queen Elizabeth, and so duly and ordinarily practised for a great part of her Reign, (within the memory of divers yet living) as it could not then be imagined that there would need any Rule or Law for the observation of the same, or that they could be thought to savour of Popery.

“And albeit since those times, for want of an express rule therein, and by subtile practices, the said Rites and Ceremonies began to fall into disuse, and in place thereof other foreign and unfitting usages by little and little to creep in; Yet, forasmuch as in Our Royal Chapels, and in many other Churches, most of them have been ever constantly used and observed, We cannot now but be very sensible of this matter, and have cause to conceive that the authors and fomenters of these jealousies, though they colour the same with a pretence of zeal, and would seem to strike only at some supposed iniquity in the said Ceremonies: Yet, as we have cause to fear, aim at Our own Royal Person, and would fain have Our good subjects imagine that we Our Self are perverted, and doe worship God in a Superstitious way, and that we intend to bring in some alteration of the Religion here established”

“But forasmuch as we well perceive that the misleaders of Our well-minded people do make the more advantage for the nourishing of this distemper among them from hence, that the foresaid Rites and Ceremonies, or some of them, are now insisted upon, but only in some Diocesses, and are not generally revived in all places, nor constantly and uniformly practised thorowout all the Churches of Our Realm, and thereupon have been liable to be quarreled and opposed by them who use them not”

Therefore the King had “thought good to give them free leave to treat in Convocation: and agree upon certain other Canons necessary for the advancement of God’s glory, the edifying of His holy Church, and the due reverence of His blessed Mysteries and Sacraments:” and further “to ratifie by Our Letters Patent under Our Great Seal of England, and to confirm the same”

It has been thought that these Canons have ceased to possess authority, owing to the language of the 13 Charles II. c. 12, § 5, A.D. 1661, where it is stated that this Act is not “to abridge or diminish the King’s Majesty’s Supremacy in Ecclesiastical matters and affairs, nor to confirm the Canons made in the year One thousand six hundred and forty, nor any of them, nor any other Ecclesiastical laws or canons not formerly confirmed, allowed, or enacted by Parliament, or by the Established Laws of the land, as they stood in the year of our Lord One thousand six hundred and thirty-nine.”

But, on consideration, it will be seen that the words are *cautionary*, and were intended to prevent any misconception as to the force of this Act, which was passed “for explanation of a Clause contained in” 17 Charles I. c. 2. The Act merely excludes these Canons from any *Parliamentary* authority which it might be supposed to confer on them; but then it does precisely the same with “any other Ecclesiastical laws or canons not formerly confirmed, allowed, or enacted by Parliament:” this necessarily includes the Canons of 1603-4, yet their authority is admitted. The Act in no way affects the recognized authority derived by the Canons of 1640, or by any others, from Royal Letters Patent: on the contrary, it helps to confirm such authority by declaring that it was not meant “to abridge or diminish the King’s Majesty’s Supremacy in Ecclesiastical matters and affairs;” and of this the confirmation of Canons was made an important part by the Act of Submission 25 Henry VIII. c. 19.

From what has now been said with reference to these four Series of Ecclesiastical Ordinances, it will be seen that only the two latter have any thing more than Historical authority: it is only to the Canons of 1603-4 and 1640 that any legal obligation still attaches: but even these no longer retain the force which they once possessed in limiting or defining or dispensing with in practice the larger and more general Rule prescribed in the Prayer Book; for the revision of that Book in 1661, sanctioned as it was by the Convocations of the two Provinces and legalized by the Act of Uniformity 13 & 14 Charles II. c. 4, provided the latest and most authoritative law for regulating the Services of the Church of England; so that if in any instance a direction of these Canons and a direction of the Prayer Book are found to be conflicting, the Canon must yield to the Prayer Book, as being of supreme authority.

It is only right, however, to observe—that, as *custom* has so long sanctioned usages in accordance with the Canons of 1603-4, and as the Ordinaries and other administrators of the Ecclesiastical Laws have allowed the superior Rule to remain in abeyance, those who do not act upon the reimposed Rubric ought not to be regarded as culpably negligent of the law: nor is it likely that they would be

considered liable to Ecclesiastical censure or punishment for the omission; unless, indeed, such omission was in disregard of an Episcopal admonition to obey the law.

The Rubric relating to the Ornaments of the Church and of the Ministers, which stood in the Books of Elizabeth and James I., is retained, then, with certain verbal changes (not however affecting its former sense) in the Prayer Book of 1662, that at present in use. And, by travelling back to "the Second Year of the Reign of King Edward the Sixth," and fixing upon the Ornaments then in use "in this Church of England, by the authority of Parliament," this Rubric passes over all changes and varieties subsequent to that year, and sets up a standard by which it is easy to decide what are now the proper Accessories of Divine Worship. It has been called "The Interpretation Clause" of the Prayer Book, and with much appropriateness; for it not only furnishes an exact mode of solving doubts which may arise as to the precise meaning of the directions which *prescribe* things to be used in Divine Service, but also it is a reliable guide in ascertaining whether any thing not prescribed is needful or suitable in executing the Offices which the Prayer Book provides.

But, though the *present authority* of this Rubric could not be disputed, the meaning of those words of it, "by the Authority of Parliament, in the Second Year of the Reign of King Edward the Sixth," had in recent times often been a subject of controversy prior to the year 1857. Then, however, the celebrated Ecclesiastical suits arising out of the opposition to certain Ornaments introduced into the Churches of St. Paul, Knightsbridge, and St. Barnabas, Pimlico, led to a definitive Judgment on this point by the existing Final Court of Appeal in Ecclesiastical Causes, viz. the Judicial Committee of Her Majesty's Privy Council¹.

In judicially interpreting this Rubric, with the view of applying it to the Ornaments complained of, the Judges drew a clear distinction between ORNAMENTS, i. e. ARTICLES "*used in the Services*," and ARTICLES "*set up in Churches as Ornaments, in the sense of decorations*."

They expressed themselves "satisfied that the construction of this Rubric which they suggested at the hearing of the case is its true meaning, and that the word 'ornaments' applies, and in this Rubric is confined to those Articles the use of which in the Services and Ministrations of the Church is prescribed by the Prayer Book of Edward the Sixth."

In proof of this they added, that "the term 'ornaments' in Ecclesiastical law is not confined, as by modern usage, to articles of decoration or embellishment, but it is used in the larger sense of the word 'ornamentum,' which, according to the interpretation of Forcellini's Dictionary, is used '*pro quocumque apparatu, seu instrumento*.' All the several articles used in the performance of the Services and Rites of the Church are 'Ornaments.' Vestments, Books, Cloths, Chalice, and Patens, are amongst Church Ornaments; a long list of them will be found extracted from Lyndwood, in Dr. Phillimore's Edition of 'Burn's Ecclesiastical Law' (vol. i. pp. 375—377). In modern times, Organs and Bells are held to fall under this denomination."

Having thus defined the term "Ornaments," their Lordships then interpreted the expressions "Authority of Parliament" and "Second Year" as connected with the Reign of Edward VI.: their conclusion was arrived at thus:—

After noticing the alterations in King Edward's Second Prayer Book (which diminished the number of the Ornaments prescribed in his First Book), and referring to the abolition of the Reformed Services by Queen Mary, they state that "on the Accession of Queen Elizabeth, a great controversy arose between the more violent and the more moderate Reformers as to the Church Service which should be re-established, whether it should be according to the First, or according to the Second Prayer Book of Edward the Sixth. The Queen was in favour of the First, but she was obliged to give way, and a compromise was made, by which the Services were to be in conformity with the Second Prayer Book, with certain alterations; but the Ornaments of the Church, whether those worn or those otherwise used by the Minister, were to be according to the First Prayer Book."

¹ The causes were argued before the Lord Chancellor (Cranworth), Lord Wensleydale, T. Pemberton Leigh (afterwards Lord Kingsdown), Sir John Patteson, and Sir William H. Maule; the Archbishop of Canterbury (Sumner) and the Bishop of London (Tait) being summoned by command of the Queen to attend and advise at the hearing. After seven days' argument in February,

their Lordships, on March 21st, made their Report, which was subsequently confirmed by the Queen in Council. The Counsel for the Appellants were Sir Fitzroy Kelly and Dr. Phillimore (now Queen's Advocate); and Dr. Bayford and Mr. A. J. Stephens for the Respondents.

Then they compare the four Directions, as to the Ornaments, which occur in the Elizabethan Act of Uniformity and the Prayer Books of 1559, 1603-4, 1662 (given already at p. lxxi), declaring of them that "they all obviously mean the same thing, that the same dresses and the same utensils, or articles, which were used under the First Prayer Book of Edward the Sixth may still be used."

Further, they discuss an important question which was raised as to the date of the Royal Assent to the Act of Uniformity which legalized the Prayer Book of 1549, and they resolve that the "use" of the Book "and the Injunctions contained in it, were established by authority of Parliament in the Second Year of Edward the Sixth, and this is the plain meaning of the Rubric." It has indeed been questioned, and with some reason, whether what can be gathered from the known records of the time warrants this decision as to the date in question; but if it be an error, it is practically unimportant in connexion with their *entire* interpretation of the Rubric; for, whether 1547—the date of King Edward's Injunctions, or 1549—the date of the First Prayer Book, be the "Second Year" mentioned in the Rubric, the result is the same, because no change was made in the Ornaments between those years. Moreover, the Rubric has now been judicially interpreted by a Court from which there lies no appeal, and therefore that interpretation, and that only, is the sole ground upon which the members of the Church of England can legally stand in endeavouring to carry out the requirements of the Rubric on Ornaments.

One thing more the Judicial Committee of the Privy Council showed in reference to the meaning of this Rubric, viz. that though it is *prescriptive*, it is not *exhaustive*: this opinion was arrived at from their consideration of the fact, that the Second Prayer Book of Edward VI. (like the First Book, and indeed the previous Service-books) "does not expressly mention" every thing which, nevertheless, it is certain was used under it, e. g. the Paten (just as the First Book does not mention, e. g. the Linen Cloth); and also from the circumstance that they had to decide whether *the Credence-table* (which is not prescribed *nominatim*) could be regarded as a Legal Ornament. The opinion of the Court is thus stated,—“Here the Rubrics of the Prayer Book become important. Their Lordships entirely agree with the opinions expressed by the learned Judges [i. e. of the Consistory and Arches Courts] in these cases, and in 'Faulkner v. Lichfield,' that in the performance of the services, rites, and ceremonies ordered by the Prayer Book, the directions contained in it must be strictly observed; that no omission and no addition can be permitted; but they are not prepared to hold that the use of all articles not expressly mentioned in the Rubric, although quite consistent with, and even subsidiary to the Service, is forbidden. Organs are not mentioned; yet because they are auxiliary to the singing, they are allowed. Pews, cushions to kneel upon, pulpit-cloths, hassocks, seats by the Communion Table, are in constant use, yet they are not mentioned in the Rubric.” So, as their Lordships further argued, there being a Rubric which "directs that at a certain point in the course of the Communion Service (for this is, no doubt, the true meaning of the Rubric) the Minister shall place the bread and wine on the Communion Table," in their judgment, "nothing seems to be less objectionable than a small side-table, from which they may be conveniently reached by the officiating Minister, and at the proper time transferred to the Communion Table."

One remark, however, may be made before quitting the consideration of this judicial rendering of the Rubric; and it is this—that, although it so completely covered the whole debateable ground by deciding that "*the same*" things "which were used under the First Prayer Book of Edward the Sixth may still be used," it does not follow that *all* such things can be legally restored now quite irrespective of any differences in the Prayer Book of 1549 as compared with that of 1662,—the one at present in use. It may not be useless to say, that before any Edwardian Ornament is re-introduced, under the terms of this decision, it must first be inquired, whether the particular Ministration in which it is proposed to employ it is now so *essentially* the same as it was in 1549 that the Ornament has the like symbolical or practical use which it had then. It will probably be found that very few indeed of those Ornaments are inapplicable at this time; but to determine this it is important to proceed now to ascertain,

First, What were the customary Ornaments of that period.

There are four sources from which it may be ascertained with considerable accuracy what "Ornaments were in the Church of England, by the authority of Parliament, in the second year of the reign of King Edward the Sixth." These are,—

I. The ancient Canon Law, which is held to have been then (as now) statutorily binding upon the Church by the 25th Henry VIII. c. 19, in all points where it is not repugnant to or inconsistent with later Ecclesiastical Law.

II. The Salisbury Missal, which was the Liturgy chiefly¹ used, and of which a new edition was published by authority in 1541: the *Bangor*, *Hereford*, and *York* books (especially the latter) may also be appealed to as illustrative of or supplementary to the Salisbury book, for they had long been more or less in use. "The Order of the Communion" of 1548 (which provided for the administration of the Lord's Supper in both kinds) directed that "until other order shall be provided," there should be no "varying of any other rite or ceremony in the Mass;" so that these Service-books continued to be used intact until the first Prayer Book of King Edward VI. was published in 1549.

III. The directions, explicit or implicit, in the Prayer Book of 1549.

IV. The Inventories of Ornaments which were made in pursuance of Edward VI.'s Instructions to the Commissioners appointed in 1552 to survey the Church goods throughout the kingdom. These Inventories are very numerous, and for the most part are preserved in the Public Record Office, Fetter Lane, London: they do not indeed exhibit such full catalogues as would have been found in 1549, for many things had been sold (especially where they were duplicates) to meet Church expenses of various kinds; and some too had been embezzled. But they are thus the more reliable as being likely to show what Articles it was deemed needful to retain for the Services then authorized. Three of these Inventories (and they are by no means the richest which might have been chosen) are here selected for comparison, as affording a probably fair specimen of the rest, viz. a Cathedral, a London Parish Church, and a Country Parish Church.

Secondly, It must be determined what Ornaments, whether by *express prescription* or by *plain implication*, are now pointed out for use in the Ministrations of the Church of England.

V. These Ornaments are to be sought in the Canons of 1603-4 and of 1640; also in the directions, explicit or implicit, of the present Book of Common Prayer.

"ORNAMENTS OF THE CHURCH."

I. ENGLISH CANONS A.D. 740 to 1463.	II. THE OLD ENGLISH LITURGIES.	III. THE PRAYER BOOK A.D. 1549.	IV. INVENTORIES.	V. MORE RECENT AUTHORITIES.
	1. Sarum. 2. Bangor. 3. York. 4. Hereford.		1. Winchester Cathedral, Oct. 3, 1552. 2. St. Martin, Outwich, London, Sept. 16, 1552. 3. Stanford-in-the-Vale, Berks, May 11, 1553.	1. Canons, 1603-4. 2. Canons, 1640. 3. The Prayer Book, 1662.
Altars of stone. A Table.	1, 2, 3, 4. Altar.	The Altar, the Lord's Table, God's board.	1. The High Altar. 2. A Communion Table. 3. A Tabull with a frame. 1, 2. Cushions.	1. A Communion Table. 2. An Altar. 3. The Lord's Table. [Desk or Cushion—needed for the Altar Book.]
Frontal for the High Altar. A clean white large linen cloth for the Altar.	1. Linen Cloth.		1, 3. Frunts for the Altar. 2. Altar Cloth. 1. Altar Cloths, white, co- loured, plain, and diaper. 2. Table Cloths, plain and diaper. 3. Altar Cloths. 1, 3. Corporis Cloths.	1. A carpet of silk or other decent stuff. 1. A fair Linen Cloth. 3. Fair white Linen Cloth.
Corporas (and Case). "A very clean cloth" for "the Priest to wipe his fingers and lips after receiving the Sacrament."	1, 2, 3, 4. Corporal. 2. Sudarium.	"laying the bread upon the Corporas."		3. A fair Linen Cloth for covering what remaineth of the Consecrated Elements. [Mandatory—needed to wipe Chalice, &c.]
Paten.	1, 2, 3, 4. Paten.	"Paten or some other comely thing." Chalice or Cup. Cruetts—implied in "putting the Wine into the Chalice . . . putting thereto a little pure and clean water."	1, 2, 3. Paten. 1, 2, 3. Chalice. 1, 2, 3. Cruetts.	3. Paten. 3. Cup or Chalice. 1. Pot or Stoup in which to bring the Wine to the Communion Table. 3. Flagon.
Chalice. Wine and Water to be used,—implying ves- sels for them.	1, 2, 3, 4. Chalice. 1, 2, 3, 4. Wine and Water brought to the Priests,—imply- ing vessels in which to bring them.			

¹ The preference which seems to have been given to the Rites of Sarum is illustrated by the circumstance, that the Convocation of Canterbury decreed, March 3, 1541, that the "use and custom

of the Church of Salisbury should be observed by all and singular clerics throughout the Province of Canterbury, in saying their canonical hours." (*Wilkins' Concilia*, iii. 861-2.)

"ORNAMENTS OF THE CHURCH" (*continued*).

I.	II.	III.	IV.	V.
Bread to be offered by the faithful—implying some presentation of it at the time.	1, 2, 3, 4. Bread, Wine, and Water, brought to the Priest, — implying some place from which they were brought.	Credence—implied in "then shall the Minister take so much Bread and Wine as shall suffice . . . and setting both the Bread and Wine upon the Altar."	Credence — unlikely to be mentioned, being commonly structural.	3. Credence — implied in "when there is a Communion the Priest shall then place upon the Table so much Bread and Wine as he shall think sufficient."
Bells, with their ropes.		Poor men's Box.	3. Poor men's Box. 2, 3. Bells, in the steeple.	3. Bason for Alms. 1. Chest for Alms. 1, 3. Bell for the Services of the Church, and for any passing out of this life. Cross—lawful as a decorative Ornament. Two Lights—the old directions for them not repealed.
Cross, for processions and for the dead. "Two Candles, or one at the least, at the time of High Mass."	1. Cross, Crucifix. 1. Two Wax Candles in Candlesticks to be carried to the Altar steps.		1, 2, 3. Cross for the Altar. 1, 2, 3. Two Candlesticks for the Altar. 1, 3. Large Candlesticks—Standards.	Standard Candlesticks—consistent with the Services.
A Cense pot.	1, 2, 3. Thurible.		1, 3. Censers. 1. Ship—for Incense. 1, 2. Spoon—for Incense. Font—unlikely to be mentioned, not being moveable.	Censer—Use of Incense never legally abolished.
Font of stone, with a lock and key.	1. Font.	Font.		1, 3. Font. 3. Vessel for Water—implied in "then to be filled with pure water." 3. Shell — consistent with "pour water."
	1, 2. Pulpit (or Ambo) for the Epistle and Gospel. 1. Seats.	Pulpit. Chair for Archbishop or Bishop.	2. Cloth for the Pulpit. 2. Organs.	1, 3. Litany Desk—implied in "some convenient place" and "the place where they are accustomed to say the Litany." 1. Stall or Reading-pew, to read Service in. 1, 3. Pulpit. 3. Kneeling - desk — for Churchings. 3. Chair for the Archbishop or Bishop. Organ—desirable. 1. The Ten Commandments. "Other chosen sentences upon the walls." (Decorative Ornaments.) 3. Rogation Days recognized.
Images, especially of the Saint to which the Church is dedicated.	1. Images.			
Banners for Rogation Days.	1. Banners.		1, 3. Banners.	
A Bier for the dead.			2. Herse Cloth for burying. 1, 3. Cloths to cover and keep clean the Linen Altar Cloth.	Bier—requisite. Pall—requisite. Covering for Linen Cloth—desirable.

Besides the "Ornaments" contained in this List, there are many others mentioned in the Inventories, which are merely Ornaments "in the sense of Decorations." Such are the following:—Curtains for the sides of Altars; Hangings for the wall behind the Altar and of the Chancel; Carpets for the Altar steps; Cloths and Veils for Lent.

There were also "Ornaments," i. e., Articles "used in the Services," which, on various grounds, are barely, or not at all, consistent with the character of the present Prayer Book Services, or with some of its directions. Thus we find:—the Pyx, or Monstrance, with its covering and canopy for the Reserved Sacrament (the former of which could only be used in circumstances which really necessitated Reservation for the Sick); Bason and Towel for the Priest to wash his hands before Consecrating; Sanctus, Saeryng, and other Bells; Light and Covering for the Easter Sepulchre; Vessels for Holy Water; the Chrysmatory for the oil of Unction in Baptism and Visitation of the Sick; the Pax for the Kiss of Peace; the Reliquary.

"ORNAMENTS OF THE MINISTERS."

I.	II.	III.	IV.	V.
Cope.	1, 2. Cope.	Cope.	1, 2, 3. Cope.	1. Cope.
Principal Mass Vestment.	1, 2, 4. Vestment.	Vestment.	2, 3. Vestment.	3. <i>General Rubric.</i>
Chesible.	1, 2. Chasuble.		1, 3. Chasuble.	"And here is to be noted, that such Ornaments of the Church, and of the Ministers thereof at all times of their Ministration, shall be retained and be in use as were in this Church of England by the Authority of Parliament, in the second year of the Reign of King Edward the Sixth."
Dalmatic (for Deacon).	1. Dalmatic.		1, 3. Deacon (i.e. Dalmatic).	
Tunic (for Sub-deacon).	1. Tunic.	Tunics.	1, 3. Sub-deacon (i. e. Tunic).	
Albe.	1, 4. Albe.	Albes.	1, 2, 3. Albes.	
Girdle.			1, 3. Stole.	
Stole.				
Maniple.				
Amice.	1, 2, 4. Amice.		2. Amice.	
		Pastoral Staff (Bp.).	1, 3. Mitre.	
			1. Crosier Staff (Bp.).	
	1. Gremial (or Apron).		1. Gloves (Bp.).	
		Rochette (Bp.).	1. Ring (Bp.).	
Surplices.	1, 2. Surplices.	Surplice.	2, 3. Surplices.	3. "Rochet" and the rest of the "Episcopal Habit."
		Hood.		1. Surplice.
				1. Hood.
				1. Tippet.

It will be seen, by an examination of these comparative Tables of Ornaments, that very few indeed of those which are mentioned in the Inventories, the old English Canons, and the Sarum and other books, are not distinctly and by name shown to be legally usable now if the combined authority of the Prayer Books of 1549 and 1662, together with that of the Canons of 1603 and 1640, is, as it must be, taken into account. Moreover, of those excepted, there is not one of which it can be fairly alleged, that it is wholly incongruous with the letter and the spirit of those Services which, in the present Prayer Book, occupy the place of the older Services in connexion with which these Ornaments were employed.

If it were necessary here to resort to a further mode of proving what Ornaments are now *lawful* in the Church of England, it would be desirable to adopt the test indicated by the Judicial Committee of the Privy Council as noticed at p. lxx. The Judges referred to a List of Church Ornaments, extracted from *Lyndwood*, in Burn's Ecclesiastical Law: they all occur in one or other of three series of those old English Canons, already summarized in the foregoing tables, viz. [1] Archbishop Grey's Constitutions, A.D. 1250; [2] Archbishop Peckham's Constitutions at Lambeth, A.D. 1281; and [3] Archbishop Winchelsey's Constitutions at Merton, A.D. 1305. These laws define what Ornaments the *Parishioners* were required to provide at those periods, and are really the basis of those Rules which professedly guide the Ecclesiastical Courts now in deciding the similar liability of Parishioners in the present day. These Constitutions are contained in *Johnson's English Canons* (Ang. Cath. Library): a comparison of them would show what was considered to be *generally necessary* for Divine Service under the Old English Rituals, and so would materially aid in determining what is *legally* requisite now, so far as the present Services are in unison with the ancient ones.

In considering the legal requirements of the general Rubric on the Ornaments of the Church and of the Ministers, it is very important to recollect that its retention in the present Book of Common Prayer was not the mere tacit permission for an existing direction to remain; for not only (as has been already shown at p. lxvi) were certain verbal changes made in the Rubric, as it had been printed in the Books of 1559 and 1604, but the question of its retention or rejection was pointedly raised by the Presbyterian party at the Savoy Conference, and was then deliberately answered by the Bishops. The Presbyterians said, "Forasmuch as this Rubric seemeth to bring back the Cope, Albe, &c., and other Vestments forbidden by the Common Prayer Book, 5 & 6 Edw. VI., and so our reasons alleged against ceremonies under our eighteenth general exception, we desire that it may be wholly left out." (Cardw., Conf. p. 314.) The Bishops replied, "§ 2. rub. 2. For the reasons given in our answer to the eighteenth general, whither you refer us, we think it fit that the Rubric continue as it is." (Ibid. p. 351.) The "reasons" here referred to are as follows:—"Prop. 18, § 1. We are now come to the main and principal demand as is pretended, viz. the abolishing the laws which impose any ceremonies, especially three,

the surplice, the sign of the cross, and kneeling. These are the yoke which, if removed, there might be peace. It is to be suspected, and there is reason for it from their own words, that somewhat else pinches, and that if these ceremonies were laid aside, and these or any other prayers strictly enjoined without them, it would be deemed a burden intolerable: it seems so by No. 7, where they desire that when the Liturgy is altered, according to the rest of their proposals, the minister may have liberty to add and leave out what he pleases." (Ibid. p. 345.) In what light the excepting Ministers viewed this answer of the Bishops may be gathered from their "Rejoinder" (London, 1661), where, in noticing it, they reply, "We have given you reason enough against the imposition of the usual ceremonies; and would you draw forth those absolute ones to increase the burden?" [*Documents relating to the Act of Uniformity, 1862. Grand Debate, &c., p. 118.*]

It is plain, therefore, that, in the judgment of the Episcopal authorities at that time, it was considered desirable to *legalize* a provision for Ornaments which, if acted upon, would conform the appearance of the Churchés and Services to those general features which they presented in the second year of the reign of Edward VI., i. e., as the Judicial Committee has decided, to that condition in which the first Prayer Book of Edward VI. designed to leave them. Indeed it seems highly probable that had Bishop Cosin, the chief reviser in 1661, been allowed entirely to guide his Episcopal brethren on this matter, he would have made the Rubric so detailed and explicit as to place it beyond the reach of controversy; for, as already noticed at p. lxvi¹, in his "*Particulars to be considered, explained, and corrected in the Book of Common Prayer,*" he says, with almost a prophetic instinct of subsequent and present controversies, "But what these Ornaments of the Church and of the Minister were, is not here specified, and they are so unknown to many, that by most they are neglected. Wherefore it were requisite that those Ornaments, used in the second year of King Edward, should be here particularly named and set forth, that there might be no difference about them." (Works, v. p. 507.) Moreover, as is also mentioned in the same note (p. lxvi), he had begun to write a List of the Ornaments, but got no further than the word "Surplice."

There does not appear to be any explanation on record to show why this suggestion, apparently so valuable, was not acted upon. Probably the ground which had to be recovered after fifteen years' banishment of the Prayer Book from Churches which had also been more or less despoiled of their Ornaments, combined with the extensively adverse temper of the time and its special manifestation in the Savoy Conference, warned the Bishops that an authorized catalogue (whether in the Prayer Book or elsewhere) of all the Legal Ornaments of King Edward's Second Year, might raise a too formidable barrier against endeavours to restore the use of any of them at that time. And so it may have been regarded as the more prudent course only to re-establish the general rule as to the Ornaments, trusting to an improved Ecclesiastical tone to develop in time its actual details.

The thirty years which have elapsed since the termination of the first quarter of this Nineteenth Century have been gradually realizing this probable expectation of a future development, in a way and to an extent with which no previous period since 1662 can be at all compared: for, indeed, through a variety of causes, there had been a more or less continuous declension from even that standard of Ritual and Ceremonial which the Restoration *practically raised*, though in fact it was considerably lower than the one *legally prescribed*. The renewed understanding and appreciation of doctrine—especially of Sacramental Doctrine—as embodied in the Formularies and taught by old and great Divines of the Church of England; the improved taste for Ecclesiastical Art; the deeper sense of the reverential proprieties with which the acts of Public Worship should be surrounded: these and other favourable circumstances have combined, notwithstanding much indifference and opposition, to produce a re-action in favour of Ceremonial and its corresponding Accessories more extensive probably than that which arose in the time of King Charles I., and, as it may reasonably be believed, of a far more stable character.

The present time, then, would seem to be a not unfavourable one for endeavouring to act upon Bishop Cosin's suggestion by *specifying* in this Annotated Prayer Book (though of course in a wholly unauthoritative way, except so far as the Law itself is therein correctly represented), "what these Ornaments of the Church and of the Ministers were" at the period referred to in the Rubric which orders

¹ Where it will be seen also that in his Durham Prayer Book he has written the exact words of Elizabeth's Act of Uniformity, except in the slight variation "at all times of their Ministration," thus putting the Rubric into its present form.

A RITUAL INTRODUCTION

that they "shall be retained, and be in use." The account already given in this Section will, it is believed, have described them with sufficient clearness and exactness: the three following Tables are designed to show more explicitly the prescribed use or the inherent fitness of the several Ornaments in connexion with those "all times of their Ministration" at which the Rubric directs the Clergy to employ them. Those which may be said to be Rubrically *essential* are distinguished from those which may be accounted as Rubrically *supplemental* by the latter being printed in *Italics*.

ORNAMENTS OF THE CHURCH.

To be used at	Mattins, Evensong, Litany, Communion.	Holy Communion.	Baptism, Public and Private; Catechizing.	Matrimony.	Visitation and Communion of the Sick.	Churching of Women.	Burial of the Dead.
Altar or Lord's Table.		—		—		To present her Offerings.	If a Celebration.
Cross or Picture.	To be always there, being a permanent Ornament, i. e. Decoration.						
Frontal and Super-frontal.	To be always there, being the ordinary Furniture.						
The Two Lights.	Evensong	—		When a Celebration.			When a Celebration.
The Linen Cloth.		—		do.	Com. of Sick.		do.
Book Rest or Cushion.		—		—	—	—	—
Corporal and Case.		—		When a Celebration.	Com. of Sick.		When a Celebration.
Fair Linen Cloth & Veil.		—		do.	do.		do.
Bason for Alms, &c.	—	—		—	—	—	do. *
Standard Candlesticks.	—	—		—	—	—	—
Paten and Chalice.		—		When a Celebration.	Com. of Sick.		When a Celebration.
Paten for Bread to be offered.		—		do.	do.		do.
Flagon for Wine and Water.		—		do.	do.		do.
Veil (Silk) to cover Vessels.		—		do.	do.		do.
Linen Palls to cover Chalice.		—		do.	do.		do.
Mandatory.		—		do.	do.		do.
Censer, &c.		—		do.	do.		—
Font and Vessel for Water.	For Public Baptisms—some convenient vessel for Private Baptism.						
Bier and Pall.		—					—
Processional Cross.	Still retained in some Cathedrals, e. g. Chichester.						
Banners.	For Rogation Days and special occasions.						
Chair.	For the Archbishop or Bishop at Ordinations and Confirmations.						

ORNAMENTS OF THE MINISTERS.

Cope or Vestment.		—		When a Celebration.			When a Celebration.
Dalmatic (for Gospeller or Deacon).		—		do.			do.
Tunicle (for Epistoler or Sub-deacon).		—		do.			do.
Albe and Girdle.		—		do.			do.
Stole.	—	—	—	—	—	—	—
Maniple and Amice.		—		When a Celebration.			When a Celebration.
Surplice (with Sleeves), Hood or Tippet.	—	—	—	—	—	—	—

EPISCOPAL ORNAMENTS.

Rochette.	—	—	Public Baptism and Catechizing.	—	—	—	—
Surplice or Albe.	—	—	do.	—	—	—	—
Cope or Vestment.	—	—	do.	—	—	—	—
Pastoral Staff.	—	—	do.	—	—	—	—
Gremial or Apron.	—	—	do.	—	—	—	—
Mitre and Ring.	—	—	do.	—	—	—	—

** The Episcopal Ornaments are the same for Confirmation, Ordination, Consecration of Churches and Burial Grounds: perhaps the Rubric at the end of the First Prayer Book, in directing "a Surplice or Albe, and a Cope or Vestment," may have intended the use of the Albe and Vestment when the whole Communion Service was used.

In any consideration of the Ornaments to be used in Divine Service, it is not only unavoidable but important to consider such points as [a] their *material*, [b] their *colour*, [c] their *form*, particularly in

reference to such of them as, by reason of long disuse, are but little known to the greater part of English Church people. The fact—that those Ornaments which have been retained in use among us do exhibit mostly their *ancient* material, colour, and form, except as altered, for the better or the worse, by any subsequent fashions—may fairly be taken to indicate what would have been the case with those Ornaments which have fallen into disuse: and this view is strongly confirmed by the very general preservation of these ancient characteristics in the Royal, Noble, Civic, Legislative, Judicial, Military, and Naval Ornaments which (unlike so many of the Ecclesiastical) have never ceased to be employed among us. Furthermore it is noteworthy that, in the very extensive modern restorations which have been accomplished, the permanent Decorations of Churches, the Altar-plate, and Altar-coverings have decidedly followed, for the most part, the ancient patterns and models which were familiar at the period selected as the Standard in the Rubric on Ornaments.

The English Church, while presenting in her Ornaments the same ordinary features which were common to the rest of Christendom, always had her own special usages, and those, too, somewhat diversified in details by several local varieties; as, indeed, was and is also the case in Kingdoms or Dioceses connected with other Branches of the Catholic Church. Though most has perished, enough remains in England of actual ancient specimens (besides the more abundant illustrations in old Illuminations) of Windows, Carvings, Monuments, Brasses, Seals, and the like, to furnish authoritative guidance, especially in regard to the *Form* of ancient Ornaments.

Moreover, in the Inventories of Church Goods, the descriptions of *Material* and *Colour* are so numerous and detailed as to supply what is, to a great extent, unavoidably lacking in these respects in the illustrations just named, owing either to the nature of them, e. g., Carvings which rarely exhibit *Colours*, or to errors which may be due, for instance, to the glass-painter or the illuminator who, perhaps, was at times less careful to give the actual colour of a Vestment in an Ecclesiastical Function than to furnish a picture in accordance with his own taste. The following Tables contain a summarized analysis of such contents of five Inventories as relate to the Vestments of the Ministers and the Choir, and also to the various Hangings or Articles employed in furnishing and decorating the Altars and Chancels: they are all of the date of 1552 and 1553, and so they exhibit accurately Ornaments which were preserved in the Churches at the very period to which the Rubric on Ornaments directs attention, when prescribing the general Rule as to the things which “shall be retained, and be in use” now in the Church of England. Three of these Inventories, viz., Holy Trinity Cathedral, Winchester, 1552; St. Martin, Outwich, London, 1552-3; and Stanford-in-the-Vale, Berks, 1553, have been used already to illustrate other points: the two additional ones now cited are St. Paul’s Cathedral, 1552, and St. Nicolas, Cole Abbey, London, 1552.

MATERIAL OF VESTMENTS AND THE NUMBER IN EACH KIND.

Cloth of Gold	30	Sarsnett	16	Fustian	6
Cloth of Silver	6	Bawdkyn	226	Buckram	2
Velvet	137	Damask	146	Dornyx	8
Satin	30	Tissue	54	Serge	1
Silk	134	Chamlett	9	Various	48
	<hr/>		<hr/>		<hr/>
	337		451		65
	<hr/>		<hr/>		<hr/>
				Total	853

A cursory inspection of these Lists of Ornaments shows at once that, as respects [a] *Material*, the choice, while amply varied, ran very much upon the richer fabrics, whether of Home or Foreign Manufacture; Cloth of Gold, and Satin of Bruges, being the more costly, were, as might be expected, the most rare; but Velvet, Satin, Silk, Bawdkyn, and the like, were not uncommonly used; though such inferior stuffs as Taffeta, Chamlett, and Fustian often occur. The nature or quality of what was to be employed seems not to have been prescribed; indeed, had there been a desire to do so (which is very improbable) the varying pecuniary abilities of Parishes would have made it needful to avoid any rule on the subject, except requiring them to provide *according to their means* the *essential* (and if they could any *supplementary*) things appertaining to the Services of the Church.

The same principle is acted upon now in the Holy Eastern Church. A Priest of that Communion informs the writer that “there are no strict rules for the *Material*: when possible, silken and brocaded Vestments are to be preferred. Where the means are circumscribed, plain linen ones are worn, or of whatever *material*, so long as it is clean, and made in the proper shape.” With them doubtless it is, as the foregoing catalogue proves it to have been with us, that the instinct of natural piety,—viz. the

devotion of the best to God's service—is not relied upon in vain. Nor was the care and cost bestowed upon the Material limited to the foundation of the Vestments or Hangings; embroidery of all kinds was abundantly displayed in pattern or powdering, whether in Silk or Gold (not seldom in the much valued Gold of Venice), so that the Sacred Name, the Crucifix, the Cross, Crowns, Angels, Imagery, Eagles, Herons, Lions, Dolphins, Swans, the Sun and Moon, Stars, Wheat-sheaves, Grapes, Flowers, and the like, adorned the Fabrics of which the Vestures were made; or composed the rich Orphreys, which were rendered all the more beautiful and costly by Pearls and Precious Stones; as though the donors desired to attain in the adornments of the Sanctuary to somewhat of the fulness of meaning contained in the Psalmist's words, "The king's daughter is all glorious within: her clothing is of wrought gold. She shall be brought unto the king in raiment of needlework." [Ps. xlv. 13, 14.]

So, again, as to [b] *Colour*: the Inventories now under examination show it to have been chiefly of *six* kinds, viz., White, Red, Blue, Green, Yellow, and Black; besides various combinations of all these. The proportions in which they existed are shown in the following Table of Vestments which were in the five churches at the date of the Inventories:—

COLOURS AND NAMES OF THE VESTMENTS.

	White.	Red.	Blue.	Green.	Yellow.	Black.	Various.	Totals.
Copes	121	107	83	40	20	13	75	459
Chasubles	28	34	24	10	7	15	37	155
Dalmatics	22	33	23	6	6	13	13	116
Tunics	22	24	27	6	6	12	26	123
Totals	193	198	157	62	39	53	151	853

It may be as well to remark here that all the *Green* Vestments in this List belonged to the two Cathedral churches, except *one* Chasuble, Dalmatic, and Tunicle, which were in St. Martin, Outwich.

Green occurs much less frequently than other colours: it was an Exeter colour, and is also found in Lists of Vestments belonging to the Northern Province; but there seems very little to indicate with any certainty when it was used, though perhaps it served for ordinary week-days, especially in Trinity-tide.

So, again, with regard to *Blue*: while it appears to have been a much more usual colour, it is often very uncertain what kind of Blue is meant, whether Cerulean or some darker shade; frequently indeed the latter is indicated by the words "blodium" and "indicus," which mean a sort of hyacinthine and darker blue; but these must not be confounded with *purple*, which is also found in the same or other Lists. The occasions, however, on which Blue or Purple was employed are somewhat conjectural, though there is more to guide: light Blue seems sometimes to have been used in Commemorations of the Blessed Virgin Mary, and a somewhat darker shade is to be seen in Illuminations of about the fifteenth Century, in Copes used at Funerals.

A similar variety is found, both as to material and colour, in the Coverings and Hangings used for the Altars and Chancels: the annexed list exhibits their Colours:—

	Gold.	Blue.	Green.	White.	Red.	Black.	Various.
Altar Coverings	3	11	6	18	6	2	22
Altar Hangings	3	1	6	8	2	2	9
Altar Curtains	—	6	8	4	2	4	10
Chancel Hangings	—	2	—	2	5	—	—
	6	20	20	32	15	8	41

Besides the colours already enumerated, others are sometimes mentioned, such as Brown, Tawney, Murrey, Pink, and Cheyney; also combinations of colours, viz., Red and Green, Paly of White and Green, Red and White, Blue and White, Blue and Yellow, White and Red chequered. These different colours, or mixtures of colours, are to be found alike in Vestments of the Ministers, or of the Altars, no less than in the Hangings of the Churches.

It is worth noticing that the more usual Ecclesiastical colours are those which may be especially accounted the Colours of England—Red, White, and Blue—being combined in the National Flag, and designating the Admirals of this Country's Fleets: possibly the close, though curious and apparently untraceable, relations which have for several centuries subsisted between the Church and the Navy¹, in the Admiralty and Ecclesiastical Courts, may have tended to perpetuate this correspondence.

¹ Dyer (*Modern Europe*, p. 189) mentions that in Spain | Don Pedro, Archbishop of Toledo, was High Admiral of Castile Philip II. brought naval matters before the Inquisition, and that | "by a then not uncommon union of offices,"

Further, it may be mentioned, as probably indicating the effect which Ecclesiastical customs produced or helped to perpetuate, that Red, Violet, and Black are mentioned, as colours worn on the Judicial Bench, according to the Term, in some Regulations made by the Judges in 1635. [See Gentleman's Magazine, Oct. 1768.] *Green*, also, appears to have been at one time a favourite colour with them.

Moreover, the retention of Red, Purple, and Green—and especially the prevalence of Red—in the rich and decent, no less than (as was once too common) in the miserable and dirty coverings of handsome or unsightly Altar-tables in the churches, are in all likelihood the traditional use of these same colours which formerly were more commonly and more variously employed in the Services of the Church of England, and that, too, not without regard to some written or unwritten rule as to the Services and Seasons at which they should be used.

That a desire has long existed, and increases, again to adopt a greater variety of colour in the Ornaments of the Church, and especially in the coverings of the Altar, is plain from what has been accomplished and is still doing: one object of this wished-for variety is the very useful one of distinguishing, and so teaching, by outward tokens, the changes of the Church Seasons and the occurrence of Ecclesiastical Holydays. For lack of any existing Rule on this subject in the Church of England, the Rule of the rest of the Western Church has not unnaturally been followed in many cases, especially as the ancient English rule or practice was either not at all known, or not easily to be collected, even by those who were aware that some leading points of it were to be found without much difficulty. As the need of some guide in this matter is becoming more general, it may not be without a really practical use to compare the old English rules with those of the Roman and the Eastern Churches: by doing this a somewhat uniform principle will probably be found, sufficient also to furnish a general rule for those who, while rightly wishing to be not out of harmony with the rest of Christendom, would with equal propriety prefer to follow any older practice of the Church of England which would afford a satisfactory direction in the absence of any definite rule authorized by living Ecclesiastical Authority.

The Roman rule is laid down with precision: the old English rule can in part be definitely ascertained, and the rest may be, with some probability, analogically conjectured from the Rubrics of the Sarum Missal compared with St. Osmund's Register and the Inventories of Church goods already noticed. The Eastern Church, as a learned Priest of it states (in reference to the Vestments of the Clergy), does not give "in her Ritual books" any such "minute rules with regard to the colours of the Vestments, as are to be found in the Western Ritual. The Church enjoins her ministers to care more for the simple purity and propriety of the vestments than for their richness. In those cases where means are at hand, she bids the ministers to wear richer vestments of any colour for the joyful seasons of the year, and Black or Red ones for the times of fasting and sorrow. Thus, in Passion week, and Great Lent, at Burials, &c., Black or Purple Vestments are worn. It is customary to wear White Silk Vestments (if possible) at Epiphany and Easter." In this description of the general and unspecific character of the Eastern rule, there is a considerable correspondence with the features of the Sarum rule just noticed.

The following Table may be considered as furnishing a fairly reliable view of these three Rules; though, for the reasons above given, the Roman rule alone is the fullest and most explicit:—

COMPARATIVE TABLE OF COLOURS ACCORDING TO THE SARUM, ROMAN, AND EASTERN USE.

Seasons.	Sarum.	Roman.	Eastern.	Festivals, &c.	Sarum.	Roman.	Eastern.
Advent—Sundays in	Red.	Violet.	Violet	Circumcision and Transfiguration	White(?)	White.	No pre-
" Week-days in	Purple	Violet.	or dark	Festival of the Name of Jesus . .	White(?)	White.	practi-
Christmas—Octave of	(prob.)		colour.	Festivals of the Holy Cross . . .	Red.	Red.	cal rule
" rest of (except Feasts	White.	White.	White	Festivals of the B. V. Mary . . .	White	White.	can be
of Martyrs)	(prob.)	White.	or bright	(perhaps some	Blue).		given for
Epiphany—Octave of	White.	White.	colour.	St. Michael and All Angels . . .	White.	White.	these: the
" rest of	White.	Green.	White if	St. John Baptist—Nativity of . .	Red (?)	White.	general
Septuagesima to Easter—Sundays.	Red.	Violet.	possible.	do. Beheading of	Red	Red.	principle
" Week-days (Ferial).	Red or	Violet.	Violet	Apostles—out of Easter-tide . .	(prob.)	Red.	which
Ash-Wednesday	Purple.		or dark	St. John Evangelist—in Christ-	Red.	Red.	regulates
Maundy Thursday	Red.	Violet.	colour.	mas-tide	White.	White.	the colour
Good Friday	Red.	Violet.	do.	St. John Evangelist, ante port. lat.	Red.	Red.	for seasons
Easter Eve	Red.	Black.	Black all	Conversion of St. Paul	uncertain	White.	applies to
		Violet.	this week	Lammas Day.—St. Peter ad Vinc.	Red.	White.	Festivals
		White	(Red al-	Evangelists—out of Easter-tide .	Red.	Red.	which
		for Mass.	lowed).	All Martyrs	Red.	Red.	are ob-
Easter—throughout (ex. In. Cross).	White.	White.	White,	" in Paschal time	White.	White.	served
			bright,				

COMPARATIVE TABLE OF COLOURS, &c.—(continued.)

Seasons.	Sarum.	Roman.	Eastern.	Festivals, &c.	Sarum.	Roman.	Eastern.
Ascension—Octave of	White.	White.	and	Holy Innocents—if not Sunday	Red	Violet.	by the
„ rest of	White	White.	mixed	„ if Sunday	(prob.).	Red.	Eastern
Vigil of Pentecost	(prob.).	Violet,	colours.	Confessors	Yellow.	White.	Church.
	Red.	Red for	White	Bishops	uncertain	White.	
		Mass,	or Green,	Doctors	do.	White.	
		or White	and	Holy Men	do.	White.	
Pentecost	Red.	Red.	Green	Virgins—not Martyrs	White.	White.	
Vigil of Holy Trinity	Red.	Red.	and	Holy Women	White.	White.	
Trinity Sunday	Red (?)	White.	mixed.	All Saints	White.	White.	
Sundays in Trinity (ex. Gr. Fe.)	Red.	Green.		Ember Seasons	Red.	Violet.	Dark co-
Week-days (Ferial) in Trinity	Green	Green.		Rogation Days	Red.	Violet.	lour.
	(perhaps).			Masses for the Dead	Black.	Black.	Black or
				Offices for the Dead	Blue or	Black.	Purple
					Purple.		(ex. East.
							week).
							Dark co-
				Vigils	uncertain	Violet.	lour.
				Dedication of a Church—Octave of	White.	White.	
				Processions	Red.	Violet.	

* In further illustration of the principle which (in the absence of detailed rules) serves to direct the Eastern Church in the choice of Colours for use in Divine Service, it may be mentioned that *White* is regarded as symbolical of Truth, *Red* of ardent Love and Passion, *Green* of the Life of Grace, and *Violet* of Penitence.

Having thus given some description of the Material and Colour of the "Ornaments of the Ministers," their [c] *Form* may be best shown by reference to the Illustrations and accompanying descriptions which will be found in the General Appendix to this volume: and some further remarks are made as to their use in the Communion Service at p. 159.

This, then, is a general outline of the Legal and Historical grounds on which may be rested the claim to use in the Church of England such principal Accessories of Divine Service as can be fairly considered to form part of the Ritual and Ceremonial heritage of the Church. The fact—that the Anglican Communion is an integral portion of that Mystical Body—furnishes the most valid reason for not being indifferent to the aspect which she should present when viewed, as is essential to a right estimate of her position, in connexion with the rest of Christendom. And the further fact—that the external features of her Public Services have come to be a subject of common and public discussion—renders it necessary that reliable information should be given to those whose opportunities of research are unavoidably, more or less, limited.

These are the considerations which have chiefly influenced the line of argument taken in this portion of the Ritual Introduction to a Volume which professes to deal more or less completely with all the various subjects contained in the Book of Common Prayer. It is hoped that what has been advanced will assist the reader in forming a satisfactory judgment on points which, it seems clear, are acquiring year by year an increasingly practical character. Much more might have been stated in explanation, or proof of the several matters considered, but an essay of this kind must bear a reasonable proportion to the other contents of the Book, and moreover it cannot advantageously be very detailed or greatly antiquarian. Those who desire to investigate more fully and particularly the various points here discussed will find in the List of Authorities at the beginning of the Volume a reference to works which may be usefully consulted.

It should be mentioned in conclusion that, while from the nature of the case an account of Ritual Accessories belonging to the Book of Common Prayer now in use, could not merely be a notice of antiquated Ecclesiastical Usages, it is nevertheless not the object of this Section specially to advocate the restoration of what it has endeavoured to prove to be conformable to the law, and consistent with the character of the English Church. The reasons which must influence, and the conditions which must regulate, the revival of long disused, however lawful, Accessories of Divine Service, are so many and so varied, as of themselves to relegate the question of their re-introduction to a sphere beyond the legitimate bounds of these pages. The purpose of this Introduction is fulfilled in the attempt to show *what* Accessories the Church of England apparently designed "to be retained." *Where* and *when* they may profitably "be in use" can only be determined by those who, being satisfied with the truth and reasonableness of what is here or elsewhere stated, are in a legitimate position to decide upon the practical application of information thus obtained.

THE BOOK
OF
Common-Prayer,
And Administration
Of the
SACRAMENTS,
AND OTHER
RITES AND CEREMONIES
Of the CHURCH,
According to the Use
Of the
CHURCH of ENGLAND;
Together with the
PSALTER or PSALMS
OF
DAVID,
Pointed as they are to be Sung or Said in CHURCHES:
AND THE
FORM OR MANNER
OF
Making, Ordaining, and Consecrating
OF
BISHOPS, PRIESTS,
AND
DEACONS.

THE TITLE OF THE PRAYER BOOK.

Common Prayer] This familiar term seems first to have been used authoritatively in a rubric to the English Litany of 1544: "It is thought convenient in this Common Prayer of Procession to have it set forth and used in the Vulgar Tongue, for stirring the people to more devotion." It is again found in the Injunctions of Edward VI., issued in 1546-7. But it is a very ancient term, being found in use as far back as A.D. 252, in St. Cyprian's Treatise on the Lord's Prayer; of which he writes, "*Publica est nobis et Communis Oratio.*"

Common Prayer and *Public Prayer* are not theologically identical, although the terms are used in the same legal sense in the respective titles of the two Acts of Uniformity. In an exact sense, *Common Prayer* is defined by the authoritative words of our Lord, "Where two or three are gathered together in My Name, there am I in the midst of them." [Matt. xviii. 20.] The *Name* of God is an expression used with great frequency in Holy Scripture to denote the *authority* of God; in the same manner as we say, that the official agents of the Sovereign act in the Name of the Sovereign, when they engage in the duties of their office. To be met together in the Name of Christ is to be met together under His authority, not as an accidental or promiscuous assembly; and officially, that is, in the presence and with the aid of His authorized agents.

Thus, true *Common Prayer* is that which is offered in Divine Service in the Church, by a Bishop or Priest (or a Deacon as *locum tenens* in some cases), in the presence and with the aid of three, or at least two other Christian persons. Such prayer presupposes a reverent assent to our Lord's application of the words, "My House¹ shall be called the house of prayer," and to those already quoted. To it also may be applied the words of St. Cyprian²:—"They continued with one accord in prayer, manifesting at the same time the instancy of their praying, and the agreement. Because God, who 'maketh men to be of one mind in an house,' admits into the house divine and eternal those only among whom is unanimous prayer."

This kind of prayer is therefore the highest kind of all. Other prayer is exalted in kind, and probably in efficacy, in proportion as it connects itself with that which is Common; as it is offered in that sense in which we are taught to say *Our Father*; as it is offered under the conviction that Christian individuals stand not alone, each one for himself before God, but are parts of one Body whereof all the members are in communion one with another through the One Intercessor, of Whom the ministers of the Church are the earthly representatives.

and administration of the Sacraments] This does not exclude the Sacraments from *Common Prayer*. The corporate work of the Church is distinctly recognized in the administration of Baptism, and the Holy Communion is the root and apex of *Common Prayer*. But it puts forward prominently the idea of a never-ceasing round of Divine Service as distinguished from the occasional (however frequent) offering of the Holy Eucharist.

other rites and ceremonies of the Church] These words claim, as a matter of course, that the substance of the Prayer Book is in accordance with the theological and devotional system of the Catholic Church: and, in connexion with those which immediately follow, they plainly enunciate the principle set forth more at large in the Thirty-fourth Article of Religion, that while that system is binding on the whole Church, yet particular Churches have a right to carry it out in their own way, according to their own "use" as to detail and ceremonial³.

¹ τὸ Κυριακόν, Kyrie, Church, the house of the Lord.

² On the Lord's Prayer, iv.

³ The phrase "Rites and Ceremonies" is not at all equivalent to our modern words *Ritual* and *Ceremonial*: but refers to the minor services of the Church, such as the Communion, or the Churning of Women. Archbishop Cranmer's fourth article of 1536 is a good illustration of the meaning intended: "IV. Of Rites and Ceremonies. As vestments in God's service; sprinkling holy water; giving holy bread; bearing candles on Candlemas Day; giving of ashes on Ash-Wednesday; bearing of palms on Palm

according to the use of the Church of England] This right was acted upon so freely in ancient days that there was a considerable variation in the details and ceremonial of Divine Service as it was celebrated in different parts of England. Each Prayer Book took its name from the place of its origin, and was thus called the "York use," the "Bangor use," the "Hereford use," the "Salisbury use," and so forth: but when uniformity of *Common Prayer* was established upon the basis of these old service-books, one "use" only retained its authority, that of the Church of England.

In modern prayer books the words "the United Church of England and Ireland" are substituted for the words "the Church of England," under an Order of Council, dated January 1, 1801; but this exercise of the Royal authority goes beyond that permitted by the Act of Uniformity; and is very misleading⁴. The two Churches are, and always have been, in communion with each other, the interchange of friendly relations has always been very free, and they have been united in a common political bond since 1801. The formularies of the Church of England have also been adopted in the Church of Ireland, but a false gloss is put upon the real title of the Prayer Book when it is printed in the unjustifiable form referred to. The Church of England can alter its own "use," and so can the Church of Ireland, but neither can control the customs of the other: and, in fact, there are some important variations in the Prayer Books of the two countries which make the expression "the use of the United Church of England and Ireland" a misnomer. The Prayer Book as it now exists is an adaptation of ancient formularies made by the Church of England alone. Its adoption by other Churches cannot alter the fact, and therefore cannot justly influence the title. However much it may be adopted therefore in Ireland, Scotland, and other possessions of the English crown, America, the Book of *Common Prayer* is still "according to the use of the Church of England,"

together with the Psalter] In the earlier Prayer Books the Psalter was printed with a separate Title-page, as distinct from the Services. The first of Bishop Cosin's "Directions to be given to the Printer," is also, "Set a fair Frontispiece at the beginning of the Book, and another before the Psalter; to be designed as the Archbishop shall direct, and after to be cut in brass." Such an engraved Title-page is affixed to the Sealed Books, and a proof copy is bound up with Cosin's own volume: but that to the Psalter was not provided. The Ordinal was bound up with the Prayer Book for the first time in 1661.

The following Tables will illustrate some of the preceding remarks, and show at a glance what changes have been authorized.

The table of the Contents of the Prayer Book is not in itself of much interest, but it has been so freely handled by modern printers that a work like the present cannot go forth without an accurate copy of the authorized form. The successive changes made in it have a certain interest, and they are therefore arranged in parallel columns in the following Table. There is thus given also a sort of bird's-eye view of the History of the Prayer Book.

Sunday; creeping to the Cross, and kissing it, and offering unto Christ before the same on Good Friday; setting up the sepulchre of Christ; hallowing the font, and other like exorcisms, and benedictions, and laudable customs: that these are not to be condemned and cast away, but continued, to put us in remembrance of spiritual things. But that none of these ceremonies have power to remit sin."—Styrie's Memorials of Cranmer, i. 89. Eccl. Hist. Soc. Ed.

A rubric at the end of the Elizabethan Prayer Books enjoins also that "every parishioner shall communicate at the least three times in the year, of which Easter to be one, and shall also receive the Sacraments and other Rites according to the order in this book appointed."

⁴ The Act of Uniformity empowers the Sovereign to alter the names of the King, Queen, and Royal Family, as occasion shall require; but to alter the name of the Church itself is a very different thing. In Marriage Licences, and in Letters of Orders, the old form is used: but in many documents the alteration has been adopted. It is right to add that in the title-page of Edward VI.'s Injunctions he is called "in earth under Christ, of the Church of England and of Ireland the supreme head."

⁵ The distinctive title, "Church of England," is very ancient, being found in Magna Charta, where it appears to be used as a familiar phrase.

THE CONTENTS.

[3

§ *Successive Titles of the Prayer Book.*

1549.	1552.	1661.
<p>The Book of the Common Prayer and Administration of the Sacraments, and other Rites and Ceremonies of the Church: after the use of the Church of England.</p> <p>Londini in Officina Richardi Graftoni Regii impressoris. Cum privilegio ad imprimendum solum. Anno Domini MDXLIX. Mense Martii.</p> <p>[Colophon.] Imprinted at London in Fleet-street, at the sign of the Sun over against the Conduit, by Edward Whitchurch. The seventh day of March, the year of our Lord 1549.</p>	<p>The Book of Common Prayer, and Administration of the Sacraments and other Rites and Ceremonies in the Church of England.</p> <p>¶ Londini, in Officina Edwardi Whytchurche.</p> <p>¶ Cum Privilegio ad Imprimendum Solum. Anno 1552.</p>	<p>The Book of Common-Prayer and Administration of the Sacraments, and other Rites and Ceremonies of the Church, according to the use of the Church of England; together with the Psalter or Psalms of David, pointed as they are to be Sung or Said in Churches; and the Form or Manner of Making, Ordaining, and Consecrating of Bishops, Priests, and Deacons.</p>

§ *Successive Tables of Contents.*

1549.	1552.-	1661.
<p><i>The Contents of this Book.</i></p> <ol style="list-style-type: none"> 1. A Preface. 2. A Table and Kalendar for Psalms and Lessons, with necessary rules pertaining to the same. 3. The Order for Matins and Evensong, throughout the year. 4. The Introits, Collects, Epistles, and Gospels, to be used at the celebration of the Lord's Supper and holy Communion through the year, with proper Psalms and Lessons, for divers feasts and days. 5. The Supper of the Lord and holy Communion, commonly called the Mass. 6. The Litany and Suffrages. 7. Of Baptism, both public and private. 8. Of Confirmation, where also is a Catechism for children. 9. Of Matrimony. 10. Of Visitation of the Sick, and Communion of the same. 11. Of Burial. 12. The purification of women. 13. A declaration of Scripture, with certain prayers to be used the first day of Lent, commonly called Ashwednesday. 14. Of Ceremonies omitted or retained. 15. Certain notes for the more plain explication and decent ministration of things contained in this book. 	<p><i>The Contents of this Book.</i></p> <ol style="list-style-type: none"> 1. A Preface. 2. Of Ceremonies, why some be abolished and some retained. 3. The order how the Psalter is appointed to be read. 4. The Table for the order of the Psalms to be said at Morning and Evening Prayer. 5. The order how the rest of holy Scripture is appointed to be read. 6. Proper Psalms and Lessons at Morning and Evening Prayer, for certain feasts and days. 7. An Almanack. 8. The Table and Kalendar for Psalms and Lessons, with necessary rules appertaining to the same. 9. The order for Morning Prayer and Evening Prayer, throughout the year. 10. The Litany. 11. The Collects, Epistles, and Gospels, to be used at the ministration of the holy Communion, throughout the year. 12. The order of the ministration of the holy Communion. 13. Baptism, both public and private. 14. Confirmation, where also is a Catechism for children. 15. Matrimony. 16. Visitation of the Sick. 17. The Communion of the Sick. 18. Burial. 19. The Thanksgiving of Women after childbirth. 20. A Commination against sinners, with certain Prayers to be used divers times in the year. 21. The form and manner of making and consecrating of Bishops, Priests, and Deacons. 	<p><i>The Contents of this Book.</i></p> <ol style="list-style-type: none"> 1. An Act for the Uniformity of Common Prayer. 2. The Preface. 3. Concerning the Service of the Church. 4. Concerning Ceremonies. 5. The Order how the Psalter is appointed to be read. 6. The Order how the rest of the holy Scripture is appointed to be read. 7. A Table of proper Lessons and Psalms. 8. Tables and Rules for the Feasts and Fasts through the whole year. 9. The Kalendar, with the Table of Lessons. 10. The Order for Morning Prayer. 11. The Order for Evening Prayer. 12. The Creed of <i>S. Athanasius</i>. 13. The Litany. 14. Prayers and Thanksgivings upon several occasions. 15. The Collects, Epistles, and Gospels, to be used at the Ministration of the holy Communion throughout the year. 16. The Order of the Ministration of the holy Communion. 17. The Order of Baptism, both publick and private. 18. The Order of Baptism for those of riper years. 19. The Catechism, with the Order for Confirmation of children. 20. Matrimony. 21. Visitation of the Sick, and Communion of the Sick. 22. Burial. 23. Thanksgiving for Women after child-bearing. 24. A Commination or Denouncing of God's anger and judgments against sinners. 25. The Psalter. 26. The Order of Prayers to be used at Sea. 27. A Form and Manner of Ordaining Bishops, Priests, and Deacons.

AN ACT

FOR THE

UNIFORMITY OF COMMON PRAYER,

and Service in the Church, and Administration of the Sacraments,

Primo Elizabethæ.

WHERE at the death of our late Sovereign Lord King *Edward* the Sixth, there remained one uniform order of Common Service, and Prayer, and of the administration of Sacraments, Rites and Ceremonies in the Church of England, which was set forth in one Book, intituled, *The Book of Common Prayer, and Administration of Sacraments, and other Rites and Ceremonies in the Church of England*, Authorized by Act of Parliament holden in the fifth and sixth years of our said late Sovereign Lord King *Edward* the Sixth, intituled, *An Act for the Uniformity of Common Prayer, and Administration of the Sacraments*; The which was repealed, and taken away by Act of Parliament, in the first year of the Reign of our late Sovereign Lady Queen *Mary*, to the great decay of the due honour of GOD, and discomfort to the professors of the truth of Christs Religion:

Be it therefore enacted by the Authority of this present Parliament, That the said Statute of Repeal, and every thing therein contained, only concerning the said Book, and the Service, Administration of Sacraments, Rites, and Ceremonies contained or appointed in, or by the said Book, shall be void and of none effect, from and after the Feast of the Nativity of Saint *John Baptist* next coming; and That the said Book, with the order of Service, and of the Administration of Sacraments, Rites and Ceremonies, with the alteration and additions therein added and appointed by this Statute, shall stand, and be, from, and after the said Feast of the Nativity of Saint *John Baptist*, in full force and effect, according to the tenour and effect of this Statute: Any thing in the foresaid Statute of Repeal to the contrary notwithstanding.

[2] And further be it Enacted by the Queens Highness, with the assent of the Lords and Commons of this present Parliament assembled, and by the Authority of the same, That all, and singular Ministers in any Cathedral, or Parish-Church, or other place within this Realm of *England, Wales*, and the Marches of the same, or other the Queens Dominions, shall from and after the Feast of the Nativity of Saint *John Baptist* next coming, be bounden to say and use the Mattens, Evensong, celebration of the LORDS Supper, and administration of each of the Sacraments, and all other Common and open Prayer, in such order and form as is mentioned in the said Book, so Authorized by Parliament in the said fifth and sixth year of the Reign of King *Edward* the Sixth; with one alteration, or addition of certain Lessons to be used on every Sunday in the year, and the form of the Letany altered, and corrected, and two sentences only added in the delivery of the Sacrament to the Communicants, and none other, or otherwise: and, That if any manner of Parson, Vicar, or other whatsoever Minister, that ought or should sing, or say Common Prayer mentioned in the said Book, or minister the Sacraments, from, and after the Feast of the Nativity of Saint *John Baptist* next coming, refuse to use the said Common Prayers, or to

minister the Sacraments in such Cathedral, or Parish-Church, or other places, as he should use to minister the same, in such order and form, as they be mentioned, and set forth in the said Book, or shall wilfully, or obstinately standing in the same, use any other Rite, Ceremony, Order, Form, or manner of celebrating of the LORDS Supper openly, or privily, or Mattens, Even song, administration of the Sacraments, or other open Prayers, than is mentioned, and set forth in the said Book, [*Open Prayer in, and through this Act, is meant that Prayer, which is for other to come unto, or hear, either in Common Churches, or private Chappels, or Oratories, commonly called the Service of the Church*] or shall preach, declare, or speak any thing in the derogation, or depraving of the said Book, or any thing therein contained, or of any part thereof, and shall be thereof lawfully convicted, according to the Laws of this Realm, by verdict of twelve men, or by his own confession, or by the notorious evidence of the fact; shall lose, and forfeit to the Queens Highness, Her Heirs, and Successors, for his first offence, the profit of all his Spiritual Benefices, or Promotions, coming, or arising in one whole year next after his conviction: And also that the person so convicted shall for the same offence suffer imprisonment by the space of six moneths, without Bail, or Mainprise: And if any such person, once convict of any offence concerning the premises, shall after his first conviction, eftsoons offend, and be thereof in form aforesaid lawfully convict; That then the same person shall for his second offence suffer imprisonment by the space of one whole year, and also shall therefore be deprived *ipso facto* of all his Spiritual Promotions; and, That it shall be lawful to all Patrons, or Donors of all and singular the same Spiritual Promotions, or any of them, to present, or collate to the same, as though the person or persons so offending were dead: and That, if any such person, or persons, after he shall be twice convicted in form aforesaid, shall offend against any of the premises the third time, and shall be thereof, in form aforesaid, lawfully convicted; That then the person so offending, and convicted the third time shall be deprived *ipso facto* of all his Spiritual Promotions, and also shall suffer imprisonment during his life: And if the person, that shall offend, and be convict in form aforesaid, concerning any of the premises, shall not be Beneficed, nor have any Spiritual Promotion; That then the same Person, so offending, and convict, shall for the first offence suffer imprisonment during one whole year next after his said conviction, without Bail or Mainprise: And if any such person not having any Spiritual Promotion, after his first conviction, shall eftsoons offend in any thing concerning the premises, and shall in form aforesaid be thereof lawfully convicted; That then the same person shall for his second offence suffer imprisonment during his life.

[3] And it is Ordained, and Enacted by the Authority aforesaid, That if any person, or persons whatsoever, after the said Feast of

the Nativity of *St. John Baptist* next coming, shall in any Enterludes, Playes, Songs, Rimes, or by other open words declare, or speak any thing in the derogation, depraving, or despising of the same Book, or of any thing therein contained, or any part thereof, or shall by open fact, deed, or by open threatenings compel, or cause, or otherwise procure, or maintain any Parson, Vicar, or other Minister in any Cathedral, or Parish-Church, or in Chappel, or in any other Place, to sing, or say any Common, or open Prayer, or to minister any Sacrament otherwise, or in any other manner, and form, than is mentioned in the said Book; or that by any of the said means shall unlawfully interrupt, or let any Parson, Vicar, or other Minister in any Cathedral, or Parish-Church, Chappel, or any other place to sing or say Common and open Prayer, or to minister the Sacraments, or any of them, in such manner, and form, as is mentioned in the said Book; That then every such person, being thereof lawfully convicted in form abovesaid, shall forfeit to the Queen our Sovereign Lady, Her Heirs, and Successors for the first offence an hundred marks: And if any person, or persons, being once convicted of any such offence, afterwards offend against any of the last recited offences, and shall in form aforesaid be thereof lawfully convict; That then the same person, so offending and convict, shall for the second offence forfeit to the Queen our Sovereign Lady, Her Heirs, and Successors Four hundred marks: And if any person, after he in form aforesaid shall have been twice convicted of any offence concerning any of the last recited offences, shall offend the third time, and be thereof in form abovesaid lawfully convict; That then every person, so offending and convict, shall for his third offence forfeit to our Sovereign Lady the Queen all his Goods and Chattels, and shall suffer imprisonment during his life: And if any person or persons, that for his first offence concerning the premisses, shall be convict in form aforesaid, do not pay the sum to be paid by vertue of his conviction, in such manner and form, as the same ought to be paid, within six weeks next after his conviction; That then every person so convict, and so not paying the same, shall for the same first offence, in stead of the said sum, suffer imprisonment by the space of six moneths without Bail or Mainprise: And if any person, or persons, that for his second offence concerning the premisses shall be convict in form aforesaid, do not pay the said sum to be paid by vertue of his conviction, and this estatute, in such manner and form, as the same ought to be paid, within six weeks next after this said second conviction; That then every person so convicted, and not paying the same, shall for the same second offence, in the stead of the said sum, suffer imprisonment during twelve moneths without Bail or Mainprise: and, That from and after the said Feast of the Nativity of *Saint John Baptist* next coming, all, and every person and persons, inhabiting within this Realm, or any other the Queens Majesties Dominions, shall diligently and faithfully, having no lawful, or reasonable excuse to be absent, endeavour themselves to resort to their Parish-Church, or Chappel accustomed, or upon reasonable let thereof, to some usual place, where Common Prayer, and such service of GOD shall be used in such time of let, upon every Sunday, and other dayes ordained and used to be kept as holy days, and then, and there to abide orderly and soberly, during the time of Common Prayer, Preachings, or other Service of GOD there to be used and ministred, upon pain of punishment by the censures of the Church; and also upon pain, that every person so offending shall forfeit for every such offence twelve pence, to be levied by the Churchwardens of the Parish, where such offence shall be done, to the use of the poor of the same Parish, of the goods, lands, and tenements of such offender, by way of distress.

[4] And for due execution hereof, the Queens most excellent Majesty, the Lords Temporal, and all the Commons in this present Parliament assembled, doth in GODS Name earnestly require, and charge all the Archbishops, Bishops, and other Ordinaries, that they shall endeavour themselves to the uttermost of their knowledges, that the due and true execution hereof may be had throughout their Diocese and Charges, as they will answer before GOD for such evils and plagues, wherewith Almighty GOD may justly punish His people for neglecting His good and whol-

some law. And for their Authority in this behalf, Be it further Enacted by the Authority aforesaid, That all and singular the same Archbishops, Bishops, and all other their officers, exercising Ecclesiastical jurisdiction, aswel in place exempt, as not exempt, within their Diocese shall have full power and Authority by this Act to reform, correct and punish by censures of the Church, all, and singular persons, which shall offend within any of their jurisdictions, or Diocese, after the said Feast of the Nativity of *Saint John Baptist* next coming, against this Act and Statute: Any other Law, Statute, Priviledge, Liberty, or Provision heretofore made, had, or suffered to the contrary notwithstanding.

[5] And it is Ordained and Enacted by the Authority aforesaid, That all and every Justice of Oyer and Determiner, or Justices of Assize shall have full power and Authority in every of their open and general Sessions to enquire, hear and determine all and all manner of offences, that shall be committed, or done contrary to any Article contained in this present Act, within the limits of the Commission to them directed, and to make process for the execution of the same, as they may do against any person being indicted before them of trespass, or lawfully convicted thereof.

[6] Provided always, and be it Enacted by the Authority aforesaid, That all and every Archbishop and Bishop shall and may at all time and times at his liberty and pleasure, joyn and associate himself by vertue of this Act to the said Justices of Oyer and Determiner, or to the said Justices of Assize, at every of the said open and general Sessions, to be holden in any place within his Diocess for and to the inquiry, hearing, and determining of the offences aforesaid.

[7] Provided also, and be it Enacted by the Authority aforesaid, That the Books concerning the said Service shall at the costs and charges of the Parishioners of every Parish, and Cathedral Church be attained, and gotten before the said Feast of the Nativity of *Saint John Baptist* next following, and that all such Parishes and Cathedral Churches, or other places, where the said Books shall be attained and gotten before the said Feast of the Nativity of *Saint John Baptist*, shall within three weeks next after the said books so attained and gotten, use the said Service, and put the same in use according to this Act.

[8] And be it further Enacted by the Authority aforesaid, That no person or persons shall be at any time hereafter impeached, or otherwise molested of or for any of the offences above mentioned, hereafter to be committed, or done contrary to this Act, unless he or they so offending be thereof indicted at the next general sessions to be holden before any such Justices of Oyer and Determiner, or Justices of Assize, next after any offence committed or done, contrary to the tenour of this Act.

[9] Provided always, and be it Ordained, and Enacted by the Authority aforesaid, That all and singular Lords of the Parliament, for the third offence above mentioned, shall be tried by their Peers.

[10] Provided also, and be it Ordained, and Enacted by the Authority aforesaid, That the Mayor of *London*, and all other Mayors, Bayliffs, and other Head-officers of all, and singular Cities, Boroughs, and Towns-corporate within this Realm, *Wales* and the Marches of the same, to the which Justices of Assize do not commonly repair, shall have full power and Authority by vertue of this Act, to enquire, hear, and determine the offences abovesaid, and every of them yearly, within fifteen days after the Feasts of *Easter*, and *saint Michael the Archangel*, in like manner and form, as Justices of Assize, and Oyer, and Determiner may do.

[11] Provided always, and be it Ordained and Enacted by the Authority aforesaid, That all and singular Archbishops, and Bishops, and every of their Chancellors, Commissaries, Archdeacons, and other Ordinaries, having any peculiar Ecclesiastical jurisdiction shall have full power and Authority by vertue of this Act, aswel to enquire in their Visitation, Synods, or elsewhere within their jurisdiction, at any other time, and place, to take accusations, and informations of all, and every the things above mentioned, done, committed, or perpetrated within the limits of their jurisdiction and Authority, and to punish the same by admonition, excommunication, sequestration, or deprivation, or

other censures, and processes, in like form, as heretofore hath been used in like cases by the Queens Ecclesiastical Laws.

[12] Provided alwaies, and be it Enacted, That whatsoever person offending in the premisses shall for the first offence receive punishment of the Ordinary, having a testimonial thereof under the said Ordinaries seal, shall not for the same offence eftsoons be convicted before the Justices; and likewise receiving for the said first offence punishment by the Justices, he shall not for the same first offence eftsoons receive punishment of the Ordinary: Any thing contained in this Act to the contrary notwithstanding.

[13] Provided always, and be it Enacted, That such ornaments of the Church and of the ministers thereof shall be retained, and be in use, as was in this Church of *England* by the Authority of Parliament in the second year of the reign of King *Edward* the Sixth, until other order shall be therein taken by Authority of the Queens Majesty, with the advice of Her Commissioners, ap-

pointed and Authorized under the great seal of *England* for causes Ecclesiastical, or of the Metropolitan of this Realm: And also, That if there shall happen any contempt, or irreverence to be used in the Ceremonies, or Rites of the Church, by the misusing of the Orders appointed in this Book; the Queens Majesty may by the like advice of the said Commissioners, or Metropolitan, ordain and publish such further Ceremonies, or Rites, as may be most for the advancement of GODS glory, the edifying of His Church, and the due reverence of CHRISTs holy Mysteries and Sacraments.

[14] And be it further Enacted by the Authority aforesaid, That all Laws, Statutes, and Ordinances, wherein, or whereby any other Service, Administration of Sacraments, or Common Prayer is limited, established, or set forth to be used within this Realm, or any other the Queens Dominions, and Countries, shall from henceforth utterly be void, and of none effect.

AN ACT

FOR THE

UNIFORMITY OF PUBLICK PRAYERS,

And Administration of Sacraments, and other Rites and Ceremonies: And for establishing the Form of Making, Ordaining, and Consecrating Bishops, Priests, and Deacons in the Church of *England*.

XIV. *Carol.* II.

WHEREAS in the first year of the late Queen *Elizabeth* there was one Uniform Order of Common Service and Prayer, and of the Administration of Sacraments, Rites and Ceremonies in the Church of *England* (agreeable to the Word of GOD, and usage of the Primitive Church) compiled by the Reverend Bishops and Clergy, set forth in one Book, Entituled, *The Book of Common Prayer, and Administration of Sacraments, and other Rites and Ceremonies in the Church of England*, and enjoyed to be used by Act of Parliament, holden in the said First year of the said late Queen, Entituled, *An Act for the Uniformity of Common Prayer, and Service in the Church, and Administration of the Sacraments*, very comfortable to all good people desirous to live in Christian conversation, and most profitable to the Estate of this Realm, upon the which the Mercy, Favour and Blessing of Almighty GOD is in no wise so readily and plentifully poured, as by Common Prayers, due using of the Sacraments, and often Preaching of the Gospel, with devotion of the hearers: And yet this notwithstanding, a great number of people in divers parts of this Realm, following their own sensuality, and living without knowledge and due fear of GOD, do wilfully and Schismatically abstain, and refuse to come to their Parish Churches and other Publick places where Common Prayer, Administration of the Sacraments, and Preaching of the Word of GOD is used upon the Sundays and other days ordained and appointed to be kept and observed as Holy days: And whereas by the great and scandalous neglect of Ministers in using the said Order, or Liturgy so set forth and enjoyed as aforesaid, great mischiefs and inconveniences, during the times of the late unhappy troubles, have

arisen and grown; and many people have been led into Factions and Schisms, to the great decay and scandal of the Reformed Religion of the Church of *England*, and to the hazard of many souls: for prevention whereof in time to come, for settling the Peace of the Church, and for allaying the present distempers, which the indisposition of the time hath contracted, The Kings Majesty (according to His Declaration of the Five and twentieth of *October*, One thousand six hundred and sixty) granted His Commission under the great Seal of *England* to several Bishops and other Divines to review the Book of Common Prayer, and to prepare such Alterations and Additions, as they thought fit to offer; And afterwards the Convocations of both the Provinces of *Canterbury* and *York*, being by his Majesty called and assembled (and now sitting) His Majesty hath been pleased to Authorize and require the Presidents of the said Convocations, and other the Bishops and Clergy of the same, to review the said Book of Common Prayer, and the Book of the Form and manner of the Making and Consecrating of Bishops, Priests, and Deacons; And that after mature consideration, they should make such Additions and Alterations in the said Books respectively, as to them should seem meet and convenient; And should exhibit and present the same to His Majesty in writing, for his further allowance or confirmation; since which time, upon full and mature deliberation, they the said Presidents, Bishops, and Clergy of both Provinces have accordingly reviewed the said Books, and have made some Alterations which they think fit to be inserted to the same; and some Additional Prayers to the said Book of Common Prayer, to be used upon proper and emergent occasions; and have ex-

hibited and presented the same unto his Majesty in writing, in one Book, Entituled, *The Book of Common Prayer, and Administration of the Sacraments, and other Rites and Ceremonies of the Church, according to the use of the Church of England, together with the Psalter, or Psalms of David, Pointed as they are to be sung or said in Churches; and the Form and Manner of Making, Ordaining, and Consecrating of Bishops, Priests, and Deacons*: All which His Majesty having duely considered hath fully approved and allowed the same, and recommended to this present Parliament, that the said Books of Common Prayer, and of the Form of Ordination and Consecration of Bishops, Priests, and Deacons, with the Alterations and Additions, which have been so made and presented to His Majesty by the said Convocations, be the Book, which shall be appointed to be used by all that Officiate in all Cathedral and Collegiate Churches and Chappels, and in all Chappels of Colledges and Halls in both the Universities, and the Colledges of *Eaton* and *Winchester*, and in all Parish-Churches and Chappels within the Kingdom of *England*, Dominion of *Wales*, and Town of *Berwick upon Tweed*, and by all that Make, or Consecrate Bishops, Priests or Deacons in any of the said Places, under such Sanctions and Penalties as the Houses of Parliament shall think fit: Now in regard that nothing conduceth more to the settling of the Peace of this Nation (which is desired of all good men) nor to the honour of our Religion, and the propagation thereof, than an Universal agreement in the Public Worship of Almighty GOD; and to the intent that every person within this Realm, may certainly know the rule, to which he is to conform in Public Worship, and Administration of Sacraments, and other Rites and Ceremonies of the Church of *England*, and the manner how, and by whom Bishops, Priests, and Deacons are, and ought to be Made, Ordained and Consecrated;

[2] Be it Enacted by the Kings most Excellent Majesty, by the advice, and with the consent of the Lords Spiritual and Temporal, and of the Commons in this present Parliament assembled, and by the Authority of the same, That all and singular Ministers, in any Cathedral, Collegiate, or Parish-Church or Chappel, or other place of Publick Worship within this Realm of *England*, Dominion of *Wales*, and Town of *Berwick upon Tweed*, shall be bound to say and use the Morning Prayer, Evening Prayer, Celebration and Administration of both the Sacraments, and all other the Publick, and Common Prayer, in such order and form as is mentioned in the said Book, annexed and joyned to this present Act, and Entituled, *The Book of Common Prayer, and Administration of the Sacraments, and other Rites and Ceremonies of the Church, according to the use of the Church of England: together with the Psalter or Psalms of David, Pointed as they are to be sung or said in Churches; and the form or manner of Making, Ordaining, and Consecrating of Bishops, Priests, and Deacons*: and That the Morning and Evening Prayers, therein contained, shall upon every Lords day, and upon all other days and occasions, and at the times therein appointed, be openly and solemnly read by all and every Minister or Curate in every Church, Chappel, or other place of Publick Worship within this Realm of *England*, and places aforesaid.

[3] And to the end that Uniformity in the Publick Worship of GOD (which is so much desired) may be speedily effected, Be it further Enacted by the Authority aforesaid, That every Parson, Vicar, or other Minister whatsoever, who now hath, and enjoyeth any Ecclesiastical Benefice, or Promotion within this Realm of *England*, or places aforesaid, shall in the Church, Chappel, or place of Publick Worship belonging to his said Benefice or Promotion, upon some Lords day before the Feast of Saint *Bartholomew*, which shall be in the year of our Lord God, One thousand six hundred sixty and two, openly, publicly, and solemnly read the Morning and Evening Prayer appointed to be read by, and according to the said Book of Common Prayer at the times thereby appointed, and after such reading thereof shall openly and publicly, before the Congregation there assembled, declare his unfeigned assent, and consent to the use of all things in the said Book contained and prescribed, in these words, and no other;

[4] *I A. B. Do here declare my unfeigned assent, and consent to all, and every thing contained, and prescribed in, and by the Book intituled, The Book of Common Prayer and Administration of the Sacraments, and other Rites, and Ceremonies of the Church, according to the use of the Church of England; together with the Psalter, or Psalms of David, Pointed as they are to be sung, or said in Churches, and the form, or manner of Making, Ordaining, and Consecrating of Bishops, Priests, and Deacons;*

[5] And, That all and every such person, who shall (without some lawful Impediment, to be allowed and approved of by the Ordinary of the place) neglect or refuse to do the same within the time aforesaid, or (in case of such Impediment) within one Moneth after such Impediment removed, shall *ipso facto* be deprived of all his Spiritual Promotions; And that from thenceforth it shall be lawful to, and for all Patrons, and Donors of all and singular the said Spiritual Promotions, or of any of them, according to their respective Rights, and Titles, to present, or collate to the same; as though the person, or persons, so offending or neglecting were dead.

[6] And be it further Enacted by the Authority aforesaid, That every person, who shall hereafter be presented, or collated, or put into any Ecclesiastical Benefice, or Promotion within this Realm of *England* and places aforesaid, shall in the Church, Chappel, or place of Publick Worship, belonging to his said Benefice or Promotion, within two Moneths next after that he shall be in the actual possession of the said Ecclesiastical Benefice or Promotion, upon some Lords day openly, publicly and solemnly Read the Morning and Evening Prayers, appointed to be Read by, and according to the said Book of Common Prayer, at the times thereby appointed, and after such Reading thereof, shall openly, and publicly before the Congregation there assembled, declare his unfeigned assent, and consent to the use of all things therein contained and prescribed, according to the form before appointed: and That all and every such person, who shall (without some lawful Impediment, to be allowed and approved by the Ordinary, of the place) neglect or refuse to do the same within the time aforesaid, or (in case of such Impediment) within one month after such Impediment removed shall *ipso facto* be deprived of all his said Ecclesiastical Benefices and Promotions; and That from thenceforth, it shall and may be lawful to, and for all Patrons, and Donors of all and singular the said Ecclesiastical Benefices and Promotions, or any of them (according to their respective Rights and Titles) to present, or collate to the same, as though the person or persons so offending, or neglecting, were dead.

[7] And be it further Enacted by the Authority aforesaid, That in all places, where the proper Incumbent of any Parsonage, or Vicarage, or Benefice with Cure doth reside on his Living, and keep a Curate, the Incumbent himself in person (not having some lawful Impediment, to be allowed by the Ordinary of the place) shall once (at the least) in every month openly and publicly Read the Common Prayers and Service, in, and by the said Book prescribed, and (if there be occasion) Administer each of the Sacraments and other Rites of the Church, in the Parish Church or Chappel, of, or belonging to the same Parsonage, Vicarage, or Benefice, in such order, manner and form, as in, and by the said Book is appointed, upon pain to forfeit the sum of Five pounds to the use of the poor of the Parish for every offence, upon conviction by confession, or proof of two credible Witnesses upon Oath, before two Justices of the Peace of the County, City, or Town-Corporate where the offence shall be committed, (which Oath the said Justices are hereby Impowred to Administer) and in default of payment within ten days, to be levied by distress, and sale of the goods and chattels of the Offender, by the Warrant of the said Justices, by the Churchwardens, or Over-seers of the Poor of the said Parish, rendering the surplusage to the party.

[8] And be it further Enacted by the Authority aforesaid, That every Dean, Canon, and Prebendary of every Cathedral, or Collegiate Church, and all Masters, and other Heads, Fellows, Chap-

lains, and Tutors of, or in any Colledge, Hall, House of Learning, or Hospital, and every Publick Professor, and Reader in either of the Universities, and in every Colledge elsewhere, and every Parson, Vicar, Curate, Lecturer, and every other person in holy Orders, and every School-master keeping any publick, or private School, and every person Instructing, or Teaching any Youth in any House or private Family as a Tutor, or School-master, who upon the first day of *May*, which shall be in the year of our Lord God, One thousand six hundred sixty two, or at any time thereafter shall be Incumbent, or have possession of any Deanry, Canonry, Prebend, Mastership, Headship, Fellowship, Professors-place, or Readers place, Parsonage, Vicarage, or any other Ecclesiastical Dignity or Promotion, or of any Curates place, Lecture, or School; or shall instruct or teach any Youth as Tutor, or School-master, shall before the Feast-day of Saint *Bartholomew*, which shall be in the year of our Lord One thousand six hundred sixty two, or at or before his, or their respective admission to be Incumbent, or have possession aforesaid, subscribe the Declaration or Acknowledgement following, *Scilicet* :

[9] *I A. B. Do declare that it is not lawful upon any pretence whatsoever to take Arms against the King; and that I do abhor that Traiterous Position of taking Arms by His Authority against His Person, or against those that are Commissionated by him; and that I will conform to the Liturgy of the Church of England, as it is now by Law established. And I do declare that I do hold, there lies no Obligation upon me, or on any other person from the Oath, commonly called the Solemn League and Covenant, to endeavour any change, or alteration of Government, either in Church, or State; and that the same was in it self an unlawful Oath, and imposed upon the Subjects of this Realm against the known Laws and Liberties of this Kingdom.*

[10] Which said Declaration and Acknowledgement shall be subscribed by every of the said Masters and other Heads, Fellows, Chaplains, and Tutors of, or in any Colledge, Hall, or House of Learning, and by every publick Professor and Reader in either of the Universities, before the Vice-Chancellor of the respective Universities for the time being, or his Deputy; And the said Declaration or Acknowledgement shall be subscribed before the respective Arch-bishop, Bishop or Ordinary of the Diocess, by every other person hereby enjoyned to subscribe the same, upon pain, that all and every of the persons aforesaid, failing in such subscription, shall lose and forfeit such respective Deanry, Canonry, Prebend, Mastership, Headship, Fellowship, Professors place, Readers place, Parsonage, Vicarage, Ecclesiastical Dignity, or Promotion, Curates place, Lecture, and School, and shall be utterly disabled, and *ipso facto* deprived of the same; and that every such respective Deanry, Canonry, Prebend, Mastership, Headship, Fellowship, Professors place, Readers place, Parsonage, Vicarage, Ecclesiastical Dignity, or Promotion, Curates place, Lecture and School shall be void, as if such person so failing were naturally dead.

[11] And if any Schoolmaster or other person, Instructing or teaching Youth in any private House or Family, as a Tutor or Schoolmaster, shall Instruct or Teach any Youth as a Tutor or Schoolmaster, before License obtained from his respective Archbishop, Bishop, or Ordinary of the Diocess, according to the Laws and Statutes of this Realm, (for which he shall pay twelve-pence onely) and before such subscription and acknowledgement made as aforesaid; Then every such School-master and other, Instructing and Teaching as aforesaid, shall for the first offence suffer three months Imprisonment without bail or mainprize; and for every second and other such offence shall suffer three months Imprisonment without bail or mainprize, and also forfeit to His Majesty the sum of five pounds.

And after such subscription made, every such Parson, Vicar, Curate, and Lecturer shall procure a certificate under the Hand and Seal of the respective Archbishop, Bishop, or Ordinary of the Diocess, (who are hereby enjoyned and required upon demand to make and deliver the same) and shall publickly and openly read the same, together with the Declaration, or Acknowledgement

aforesaid, upon some Lords day within three months then next following, in his Parish Church where he is to officiate, in the presence of the Congregation there assembled, in the time of Divine Service; upon pain that every person failing therein shall lose such Parsonage, Vicarage, or Benefice, Curates place, or Lecturers place respectively, and shall be utterly disabled, and *ipso facto* deprived of the same; And that the said Parsonage, Vicarage, or Benefice, Curates place or Lecturers place shall be void, as if he was naturally dead.

[12] Provided always, that from and after the Twenty fifth day of *March*, which shall be in the year of our Lord God, One thousand six hundred eighty two, there shall be omitted in the said Declaration or Acknowledgement so to be subscribed and read, these words following, *scilicet*,

And I do declare that I do hold there lies no obligation on me, or on any other person from the Oath, commonly called The solemn League and Covenant, to endeavour any change, or alteration of Government either in Church or State; And that the same was in it self an unlawful Oath, and imposed upon the Subjects of this Realm against the known Laws and Liberties of this Kingdom;

So as none of the persons aforesaid shall from thenceforth be at all obliged to subscribe or read that part of the said Declaration or Acknowledgement.

[13] Provided always, and be it Enacted, That from and after the Feast of Saint *Bartholomew*, which shall be in the year of our Lord, One thousand six hundred sixty and two, no person, who now is Incumbent, and in possession of any Parsonage, Vicarage, or Benefice, and who is not already in holy Orders by Episcopal Ordination, or shall not before the Feast-day of Saint *Bartholomew* be ordained Priest or Deacon, according to the form of Episcopal Ordination, shall have, hold, or enjoy the said Parsonage, Vicarage, Benefice with Cure or other Ecclesiastical Promotion within this Kingdom of *England*, or the Dominion of *Wales*, or Town of *Berwick upon Tweed*; but shall be utterly disabled, and *ipso facto* deprived of the same; and all his Ecclesiastical Promotions shall be void, as if he was naturally dead.

[14] And be it further Enacted by the Authority aforesaid, That no person whatsoever shall thenceforth be capable to be admitted to any Parsonage, Vicarage, Benefice, or other Ecclesiastical Promotion or Dignity whatsoever, nor shall presume to Consecrate and Administer the holy Sacrament of the LORDS Supper, before such time as he shall be Ordained Priest, according to the form and manner in, and by the said Book prescribed, unless he have formerly been made Priest by Episcopal Ordination, upon pain to forfeit for every offence the sum of One hundred pounds; (one moiety thereof to the Kings Majesty, the other moiety thereof to be equally divided between the poor of the Parish where the offence shall be committed, and such person, or persons as shall sue for the same by Action of Debt, Bill, Plaint, or Information in any of his Majesties Courts of Record; wherein no Essoign, Protection, or Wager of Law shall be allowed) And to be disabled from taking, or being admitted into the Order of Priest, by the space of one whole year then next following.

[15] Provided that the Penalties in this Act shall not extend to the Foreiners or Aliens of the Forein Reformed Churches allowed, or to be allowed by the Kings Majesty, His Heirs and Successors, in *England*.

[16] Provided always, That no title to confer, or present by lapse shall accrue by any avoidance, or deprivation *ipso facto* by vertue of this Statute, but after six months after notice of such avoidance, or deprivation given by the Ordinary to the Patron, or such sentence of deprivation openly and publickly read in the Parish Church of the Benefice, Parsonage, or Vicarage becoming void, or whereof the Incumbent shall be deprived by vertue of this Act.

[17] And be it further Enacted by the Authority aforesaid, That no Form, or Order of Common Prayers, Administration of Sacraments, Rites or Ceremonies shall be openly used in any Church, Chappel, or other Publick place of or in any Colledge, or Hall in either of the Universities, the Colledges of *Westminster*, *Win-*

chester, or Eaton, or any of them, other than what is prescribed and appointed to be used in and by the said Book; and That the present Governour, or Head of every Colledge and Hall in the said Universities, and of the said Colledges of *Westminster*, *Winchester*, and *Eaton*, within one month after the Feast of Saint *Bartholomew*, which shall be in the year of our Lord, One thousand six hundred sixty and two: And every Governour or Head of any of the said Colledges, or Halls, hereafter to be elected, or appointed, within one month next after his Election, or Collation, and Admission into the same Government, or Headship, shall openly and publickly in the Church, Chappel, or other Publick place of the same Colledge, or Hall, and in the presence of the Fellows and Scholars of the same, or the greater part of them then resident, Subscribe unto the Nine and thirty Articles of Religion, mentioned in the Statute made in the thirteenth year of the Reign of the late Queen *Elizabeth*, and unto the said Book, and declare his unfeigned assent and consent unto, and approbation of the said Articles, and of the same Book, and to the use of all the Prayers, Rites, and Ceremonies, Forms, and Orders in the said Book prescribed, and contained according to the form aforesaid; and that all such Governours, or Heads of the said Colledges and Halls, or any of them as are, or shall be in holy Orders, shall once at least in every Quarter of the year (not having a lawful Impediment) openly and publickly Read the Morning Prayer, and Service in and by the said Book appointed to be Read in the Church, Chappel, or other Publick place of the same Colledge or Hall, upon pain to lose, and be suspended of, and from all the Benefits and Profits belonging to the same Government or Headship, by the space of Six months, by the Visitor or Visitors of the same Colledge or Hall; And if any Governour or Head of any Colledge or Hall, Suspended for not Subscribing unto the said Articles and Book, or for not Reading of the Morning Prayer and Service as aforesaid, shall not at, or before the end of Six months next after such suspension, Subscribe unto the said Articles and Book, and declare his consent thereunto as aforesaid, or read the Morning Prayer and Service as aforesaid, then such Government or Headship shall be *ipso facto* void.

[18] Provided always, That it shall and may be lawful to use the Morning and Evening Prayer, and all other Prayers and Service prescribed in and by the said Book, in the Chappels or other Publick places of the respective Colledges and Halls in both the Universities, in the Colledges of *Westminster*, *Winchester*, and *Eaton*, and in the Convocations of the Clergies of either Province in Latine; Any thing in this Act contained to the contrary notwithstanding.

[19] And be it further Enacted by the Authority aforesaid, That no person shall be, or be received as a Lecturer, or permitted, suffered, or allowed to Preach as a Lecturer, or to Preach, or Read any Sermon or Lecture in any Church, Chappel, or other place of Publick worship, within this Realm of *England*, or the Dominion of *Wales*, and Town of *Berwick upon Tweed*, unless he be first approved and thereunto Licensed by the Archbishop of the Province, or Bishop of the Diocess, or (in case the See be void) by the Guardian of the Spirituallties, under his Seal, and shall in the presence of the same Archbishop, or Bishop, or Guardian Read the Nine and thirty Articles of Religion, mentioned in the Statute of the Thirteenth year of the late Queen *Elizabeth*, with Declaration of his unfeigned assent to the same; and That every person, and persons who now is, or hereafter shall be Licensed, Assigned, Appointed, or Received as a Lecturer, to preach upon any day of the week in any Church, Chappel, or place of Publick worship within this Realm of *England*, or places aforesaid, the first time he Preacheth (before his Sermon) shall openly, publickly, and solemnly Read the Common Prayers and Service in and by the said Book appointed to be Read for that time of the day, and then and there publickly and openly declare his assent unto, and approbation of the said Book, and to the use of all the Prayers, Rites and Ceremonies, Forms and Orders therein contained and prescribed, according to the Form before appointed in this Act; And also shall upon the first Lecture-day of every month afterwards, so long as he continues Lecturer, or Preacher

there, at the place appointed for his said Lecture or Sermon, before his said Lecture or Sermon, openly, publickly, and solemnly Read the Common Prayers and Service in and by the said Book appointed to be read for that time of the day, at which the said Lecture or Sermon is to be Preached, and after such Reading thereof, shall openly and publickly, before the Congregation there assembled, declare his unfeigned assent and consent unto, and approbation of the said Book, and to the use of all the Prayers, Rites and Ceremonies, Forms and Orders therein contained and prescribed, according to the form aforesaid; and, That all and every such person and persons who shall neglect or refuse to do the same, shall from thenceforth be disabled to Preach the said, or any other Lecture or Sermon in the said, or any other Church, Chappel, or place of Publick worship, until such time as he and they shall openly, publickly, and solemnly Read the Common Prayers and Service appointed by the said Book, and Conform in all points to the things therein appointed and prescribed, according to the purport, true intent, and meaning of this Act.

[20] Provided alwaies, that if the said Sermon or Lecture be to be Preached or Read in any Cathedral, or Collegiate Church or Chappel, it shall be sufficient for the said Lecturer openly at the time aforesaid, to declare his assent and consent to all things contained in the said Book, according to the form aforesaid.

[21] And be it further Enacted by the Authority aforesaid, That if any person who is by this Act disabled to Preach any Lecture or Sermon, shall during the time that he shall continue and remain so disabled, Preach any Sermon, or Lecture; That then for every such offence the person and persons so offending shall suffer Three months Imprisonment in the Common Gaol without Bail or mainprise, and that any two Justices of the Peace of any County of this Kingdom and places aforesaid, and the Mayor or other chief Magistrate of any City, or Town-Corporate, within the same, upon Certificate from the Ordinary of the place made to him or them of the offence committed, shall, and are hereby required to commit the person or persons so offending to the Gaol of the same County, City, or Town Corporate accordingly.

[22] Provided alwaies, and be it further Enacted by the Authority aforesaid, That at all and every time and times, when any Sermon or Lecture is to be Preached, the Common Prayers and Service in and by the said Book appointed to be Read for that time of the day, shall be openly, publickly, and solemnly Read by some Priest, or Deacon, in the Church, Chappel, or place of Publick worship, where the said Sermon or Lecture is to be preached, before such Sermon or Lecture be Preached; And that the Lecturer then to Preach shall be present at the Reading thereof.

[23] Provided nevertheless, That this Act shall not extend to the University-Churches in the Universities of this Realm, or either of them, when or at such times as any Sermon or Lecture is Preached or Read in the same Churches, or any of them, for, or as the publick University-Sermon or Lecture; but that the same Sermons and Lectures may be Preached or Read in such sort and manner as the same have been heretofore Preached or Read; This Act, or any thing herein contained to the contrary thereof in any wise notwithstanding.

[24] And be it further Enacted by the Authority aforesaid, That the several good Laws, and Statutes of this Realm, which have been formerly made, and are now in force for the Uniformity of Prayer and Administration of the Sacraments, within this Realm of *England*, and places aforesaid, shall stand in full force and strength to all intents and purposes whatsoever, for the establishing and confirming of the said Book; Entituled, *The Book of Common Prayer, and Administration of the Sacraments, and other Rites and Ceremonies of the Church, according to the use of the Church of England; together with the Psalter or Psalms of David, Pointed as they are to be sung or said in Churches; and the form or manner of Making, Ordaining, and Consecrating of Bishops, Priests, and Deacons*; herein before mentioned to be joynd and annexed to this Act; and shall be applied, practised, and put in ure for the punishing of all offences contrary to the said Laws, with relation to the Book aforesaid, and no other.

[25] Provided alwaies, and be it further Enacted by the Authority aforesaid, That in all those Prayers, Litanies, and Collects,

which do any way relate to the King, Queen, or Royal Progeny, the Names be altered and changed from time to time, and fitted to the present occasion, according to the direction of lawful Authority.

[26] Provided also, and be it Enacted by the Authority aforesaid, That a true Printed Copy of the said Book, Entituled, *The Book of Common Prayer and Administration of the Sacraments, and other Rites and Ceremonies of the Church, according to the use of the Church of England; together with the Psalter, or Psalms of David, Pointed as they are to be sung or said in Churches; and the form and manner of Making, Ordaining, and Consecrating of Bishops, Priests, and Deacons*, shall at the costs and charges of the Parishioners of every Parish-Church, and Chappelry, Cathedral Church, Colledge, and Hall, be attained and gotten before the Feast-day of Saint *Bartholomew*, in the year of our Lord, One thousand six hundred sixty and two, upon pain of forfeiture of Three pounds by the month, for so long time as they shall then after be unprovided thereof, by every Parish, or Chappelry, Cathedral Church, Colledge, and Hall, making default therein.

[27] Provided always, and be it Enacted by the Authority aforesaid, That the Bishops of *Hereford, Saint Davids, Asaph, Bangor, and Landaff*, and their Successors shall take such order among themselves, for the souls health of the Flocks committed to their Charge within *Wales*, That the Book hereunto annexed be truly and exactly Translated into the *Brittish or Welsh* Tongue, and that the same so Translated and being by them, or any three of them at the least viewed, perused, and allowed, be Imprinted to such number at least, so that one of the said Books so Translated and Imprinted, may be had for every Cathedral, Collegiate, and Parish-Church, and Chappel of Ease in the said respective Diocesses, and places in *Wales*, where the *Welsh* is commonly spoken or used before the First day of *May*, One thousand six hundred sixty five; and, That from and after the Imprinting and publishing of the said Book so Translated, the whole Divine Service shall be used and said by the Ministers and Curates throughout all *Wales* within the said Diocesses, where the *Welsh* Tongue is commonly used, in the *Brittish or Welsh* Tongue, in such manner and form as is prescribed according to the Book hereunto annexed to be used in the *English* Tongue, differing nothing in any Order or Form from the said *English* Book; for which Book, so Translated and Imprinted, the Church-wardens of every of the said Parishes shall pay out of the Parish-money in their hands for the use of the respective Churches, and be allowed the same on their Account; and, That the said Bishops and their Successors, or any Three of them, at the least, shall set and appoint the price, for which the said Book shall be sold; And one other Book of Common Prayer in the *English* Tongue shall be bought and had in every Church throughout *Wales*, in which the Book of Common Prayer in *Welsh* is to be had, by force of this Act, before the First day of *May*, One thousand six hundred sixty and four, and the same Book to remain in such convenient places, within the said Churches, that such as understand them may resort at all convenient times to read and peruse the same, and also such as do not understand the said Language, may by conferring both Tongues together, the sooner attain to the knowledge of the *English* Tongue; Any thing in this Act to the contrary notwithstanding; And until Printed Copies of the said Book so to be Translated may be had and provided, the Form of Common Prayer, established by Parliament before the making of this Act, shall be used as formerly in such parts of *Wales*, where the *English* Tongue is not commonly understood.

[28] And to the end that the true and perfect Copies of this Act, and the said Book hereunto annexed may be safely kept, and perpetually preserved, and for the avoiding of all disputes for the time to come; Be it therefore Enacted by the Authority aforesaid, That the respective Deans and Chapters of every Cathedral, or Collegiate Church, within *England* and *Wales* shall at their proper costs and charges, before the twenty fifth day of *December*, One thousand six hundred sixty and two, obtain under the Great Seal of *England* a true and perfect printed Copy of this Act, and of the said Book annexed hereunto, to be by the said Deans and

Chapters, and their Successors kept and preserved in safety for ever, and to be also produced, and showed forth in any Court of Record, as often as they shall be thereunto lawfully required; And also there shall be delivered true and perfect Copies of this Act, and of the same Book into the respective Courts at *Westminster*, and into the Tower of *London*, to be kept and preserved for ever among the Records of the said Courts, and the Records of the Tower, to be also produced and showed forth in any Court as need shall require; which said Books so to be exemplified under the Great Seal of *England*, shall be examined by such persons as the Kings Majesty shall appoint under the Great Seal of *England* for that purpose, and shall be compared with the Original Book hereunto annexed, and shall have power to correct, and amend in writing any Error committed by the Printer in the printing of the same Book, or of any thing therein contained, and shall certifie in writing under their Hands and Seals, or the Hands and Seals of any Three of them at the end of the same Book, that they have examined and compared the same Book, and find it to be a true and perfect Copy; which said Books, and every one of them so exemplified under the Great Seal of *England*, as aforesaid, shall be deemed, taken, adjudged, and expounded to be good, and available in the Law to all intents and purposes whatsoever, and shall be accounted as good Records as this Book it self hereunto annexed; Any Law or Custom to the contrary in any wise notwithstanding.

[29] Provided also, That this Act or any thing therein contained shall not be prejudicial or hurtful unto the Kings Professor of the Law within the University of *Oxford*, for, or concerning the Prebend of *Shipton*, within the Cathedral Church of *Sarum*, united and annexed unto the place of the same Kings Professor for the time being, by the late King *James* of blessed memory.

[30] Provided always, That whereas the Six and thirtieth Article of the Nine and thirty Articles agreed upon by the Arch-bishops, and Bishops of both Provinces, and the whole Clergy in the Convocation holden at *London*, in the year of our Lord, One thousand five hundred sixty two, for the avoiding of diversities of Opinions, and for establishing of consent, touching true Religion, is in these words following, *viz.*

That the Book of Consecration of Archbishops, and Bishops, and Ordaining of Priests and Deacons, lately set forth in the time of King Edward the Sixth, and confirmed at the same time by Authority of Parliament, doth contain all things necessary to such Consecration and Ordaining, neither hath it any thing that of itself is superstitious, and ungodly; And therefore whosoever are Consecrated or Ordered according to the Rites of that Book, since the second year of the aforesaid King Edward unto this time, or hereafter shall be Consecrated or Ordered according to the same Rites; We decree all such to be rightly, orderly, and lawfully Consecrated and Ordered;

[31] It be Enacted, and be it therefore enacted by the Authority aforesaid, That all Subscriptions hereafter to be had or made unto the said Articles, by any Deacon, Priest, or Ecclesiastical person, or other person whatsoever, who by this Act or any other Law now in force is required to Subscribe unto the said Articles, shall be construed and taken to extend, and shall be applied (for and touching the said Six and thirtieth Article) unto the Book containing the form and manner of Making, Ordaining, and Consecrating of Bishops, Priests, and Deacons in this Act mentioned, in such sort and manner as the same did heretofore extend unto the Book set forth in the time of King *Edward* the Sixth, mentioned in the said Six and thirtieth Article; Any thing in the said Article, or in any Statute, Act, or Canon heretofore had or made, to the contrary thereof in any wise notwithstanding.

[32] Provided also, That the Book of Common Prayer, and Administration of the Sacraments and other Rites and Ceremonies of this Church of *England*, together with the form and manner of Ordaining, and Consecrating Bishops, Priests, and Deacons heretofore in use, and respectively established by Act of Parliament in the First and Eighth years of Queen *Elizabeth*, shall be still used and observed in the Church of *England*, until the Feast of Saint *Bartholomew*, which shall be in the year of our Lord God, One thousand six hundred sixty and two.

THE PREFACE.

[A.D. 1661.]

IT hath been the wisdom of the Church of *England*, ever since the first compiling of her Publick Liturgy, to keep the mean between the two extremes, of too much stiffness in refusing, and of too much easiness in admitting any variation from it. For, as on the one side common experience sheweth, that where a change hath been made of things advisedly established (no evident necessity so requiring) sundry inconveniences have thereupon ensued; and those many times more, and greater than the evils, that were intended to be remedied by such change: So on the other side, the particular Forms of Divine worship, and the Rites, and Ceremonies appointed to be used therein, being things in their own nature Indifferent, and alterable, and so acknowledged; it is but reasonable, that upon weighty and important considerations, according to the various exigency of times and occasions, such changes and alterations should be made therein, as to those that are in place of Authority should from

THE PREFACE.

This was placed before the Book of Common Prayer in 1661, and with a special regard to the circumstances of the times, the country having just emerged from the Great Rebellion, and the Church of England from a very great persecution. Under such circumstances it is impossible not to admire the temperate and just tone which characterizes it throughout.

The writer of this Preface was Sanderson, Bishop of Lincoln, who was probably chosen on account of qualifications such as would fit him for composing in this tone an explanation of the course which it had been necessary to take, and which had been taken, with reference to the Book of Common Prayer. He is, and was then, well known for his works on Conscience, and on the Obligation of an Oath: and he was looked up to with great respect by all parties in those days of religious division.

"For the satisfying all the dissenting brethren and other," says Kennett, in his Register (p. 633), "the Convocation's reasons for the alterations and additions to the Liturgy were by them desired to be drawn up by Dr. Sanderson, which being done by him, and approved by them, was appointed to be printed before the Liturgy, and may be now known by this Title, *The Preface*, and begins thus, *It hath been the wisdom of the Church, &c.*" In the Acts of the Upper House of Convocation it is recorded that "on Monday the 2nd of December, the Preface or Introduction to the Common Prayer Book was brought in and read." It was referred to a Committee composed of Wren, Bishop of Ely; Skinner, Bishop of Oxford; Henchman, Bishop of Salisbury; and Griffith, Bishop of St. Asaph, and some amendments were made in it as it passed through their hands.

first compiling] This is a phrase which could hardly have dropped from Sanderson's exact pen. No doubt the period referred to is that of the Reformation; but as every page of the following work will show, the change which then took place in the Divine Worship of the Church of England was founded on offices which were re-formed out of the old ones, not "compiled" in any true sense; and that the addition of "first" to the word adopted is calculated to misrepresent the true origin of our "publick Liturgy."

in their own nature Indifferent] This and other apologetic expressions of the Preface must be read by the light of contemporary history. But it is undoubtedly true that *in their own nature*, Rites and Ceremonies are "indifferent." Their importance arises from the relation in which they are placed with reference to God as the Object of worship, and man as the

worshipper of God. That relation being established, what was indifferent in its own nature becomes of high import through the new character which is thus given to it.

alterable] In the 34th Article of Religion this statement is more elaborately set forth: "Of the Traditions of the Church.—It is not necessary that Traditions and Ceremonies be in all places one, and utterly like; for at all times they have been divers, and may be changed according to the diversities of countries, times, and men's manners, so that nothing be ordained against God's Word. Whosoever through his private judgment, willingly and purposely, doth openly break the traditions and ceremonies of the Church, which be not repugnant to the Word of God, and be ordained and approved by common authority, ought to be rebuked openly, (that others may fear to do the like,) as he that offendeth against the common order of the Church, and hurteth the authority of the Magistrate, and woundeth the consciences of the weak brethren.

"Every particular or national Church hath authority to ordain, change, and abolish, ceremonies or rites of the Church ordained only by man's authority, so that all things be done to edifying."

those that are in place of Authority] Who are the properly authorized persons may also be known from the 20th Article of Religion: "Of the authority of the Church.—The Church hath power to decree Rites or Ceremonies, and authority in Controversies of Faith: And yet it is not lawful for the Church to ordain any thing that is contrary to God's Word written, neither may it so expound one place of Scripture, that it be repugnant to another. Wherefore, although the Church be a witness and a keeper of holy Writ, yet, as it ought not to decree any thing against the same, so besides the same ought it not to enforce any thing to be believed for necessity of Salvation."

As will be seen from the Historical Introduction to this volume, this principle was carried out by throwing the whole responsibility of revising the older Prayer Book on the Convocations of Canterbury and York, which officially represented the Church of England. Statutable authority was given to the work of the Church by the Crown in Parliament, in 14 Carol. II. The principle is further enunciated in the succeeding words of the Preface, where the "Princes" or reigning Sovereigns are named, but the whole work of revision during their respective reigns is attributed to the Church, which "upon just and weighty considerations her thereunto moving, hath yielded to make such alterations in some particulars, as in the respective times of those sovereigns were thought convenient."

time to time seem either necessary or expedient. Accordingly we find, that in the Reigns of several Princes of blessed memory since the Reformation, the Church, upon just and weighty considerations her thereunto moving, hath yielded to make such alterations in some particulars, as in their respective times were thought convenient: Yet so, as that the main Body and Essentials of it (as well in the chiefest materials, as in the frame and order thereof) have still continued the same unto this day, and do yet stand firm and unshaken, notwithstanding all the vain attempts and impetuous assaults made against it by such men as are given to change, and have always discovered a greater regard to their own private fancies and interests, than to that duty they owe to the publick.

By what undue means, and for what mischievous purposes the use of the Liturgy (though enjoined by the Laws of the Land, and those Laws never yet repealed) came, during the late unhappy confusions, to be discontinued, is too well known to the world, and we are not willing here to remember. But when, upon His Majesty's happy Restoration, it seemed probable, that, amongst other things, the use of the Liturgy also would return of course (the same having never been legally abolished) unless some timely means were used to prevent it; those men who under the late usurped powers had made it a great part of their business to render the people disaffected thereunto, saw themselves in point of reputation and interest concerned (unless they would freely acknowledge themselves to have erred, which such men are very hardly brought to do) with their utmost endeavours to hinder the restitution thereof. In order whereunto divers Pamphlets were published against the Book of *Common Prayer*, the old Objections mustered up, with the addition of some new ones more than formerly had been made, to make the number swell. In fine great importunities were used to His Sacred Majesty, that the said Book might be Revised, and such Alterations therein, and Additions thereunto made, as should be

vain attempts and impetuous assaults] The unreasonable conduct of those who opposed the restoration of the Church and her devotional system was scarcely more conspicuous than the fierce energy by which it was characterized. For four months these "impetuous assaults" were carried on in the Savoy Conference; and abundant evidence was given that "private fancies and interests" had much stronger influence than the public good. Baxter, the chief leader of the opposition, composed a substitute for the Prayer Book which dissenting congregations could not be got to use, any more than the Church of England could be prevailed on to adopt it; and yet on such a private fancy as this most of that bitter opposition centred. Nor must it be forgotten that "private interest" was deeply concerned, since the constitutional restoration of the Church and the Prayer Book necessarily involved the restoration of the surviving clergy to the benefices which men who were not priests of the Church of England had wrenched out of their hands. These facts are referred to simply to show that the expressions here used in the Preface are not those of bitterness or controversy, but plain statements of what actually occurred; and which it was necessary to mention for the sake of explanation, as ordered by Convocation.

*divers Pamphlets*¹] The most important reply to these

¹ It may be interesting and useful to append the titles of some of these Pamphlets that were published before December, 1660:—

The Old Nonconformist, touching the Book of Common Prayer and Ceremonies. 4to. 40 pp. 1660.

Presbyterial Ordination vindicated . . . , with a brief discourse concerning imposed Forms of Prayer and Ceremonies. 4to. 48 pp. 1660.

Erastus Junior, by Josiah Webb, Gent., a serious detester of the dregs of the Anti-christian Hierarchy yet remaining among us. 4to. 1660. [The author was supposed to be a Romanist.]

The Judgment of Foreign divines, as well from Geneva as other parts, touching the Discipline, Liturgy, and Ceremonies of the Church of England. With a letter from Calvin to Knox on the same subject. 4to. 1660

pamphlets, next to the Prayer Book itself, was "A Collection of Articles, Injunctions, Canons, Orders, Ordinances, and Constitutions Ecclesiastical, with other Public Records of the Church of England; chiefly in the times of K. Edward VIth, Q. Elizabeth, and K. James. Published to vindicate the Church of England, and to promote Uniformity and Peace in the same. And humbly presented to the Convocation." This collection was made by Dr. Sparrow, afterwards Bishop successively of Exeter and Norwich. It was published in 1661, and was a kind of legal or constitutional sequel to a well-known work which he had printed in December, 1660, "A Rationale upon the Book of Common Prayer, wherein that Service is vindicated from the grand accusation of Superstition, by showing that it is a Reasonable Service, and so not Superstitious."

great importunities] This refers to the deputations sent to the King before and after he came into England, by the Presbyterians; which led to the Savoy Conference. The word "persua-

Reasons showing the necessity of Reformation of the public doctrine. Offered to the consideration of Parliament by divers Ministers of sundry Counties of England. 4to. 1660.

The Common Prayer unmasked. 4to. 1660.

The Common Prayer Book no Divine Service; or, a small Curb to the Bishops' Career, &c. By Vavasour Powell. 4to. 1660.

Beams of former Light, discovering how evil it is to impose doubtful and disputable Forms and Practices upon Ministers. 4to. 1660.

Reasons showing the Necessity of the Reformation of the Public Doctrine, Worship, Rites and Ceremonies, Church government and discipline. Reputed to be (but indeed are not) established by Law. By Cornelius Burgess. 4to. 1660.

Smectymnus Redivivus. 4to. 1660.

A Treatise of Divine Worship. Tending to prove that the Ceremonies imposed upon the Ministers of the Gospel in England in present Controversy, are in their present use unlawful. Printed 1664. 4to. 1660.

["Exceptions against the Common Prayer" was not printed until 1661, after the King had yielded to the "importunities" referred to; and was not therefore one of these pamphlets.]

thought requisite for the ease of tender Consciences : whereunto His Majesty, out of his pious inclination to give satisfaction (so far as could be reasonably expected) to all his subjects of what persuasion soever, did graciously condescend.

In which review we have endeavoured to observe the like Moderation as we find to have been used in the like case in former times. And therefore of the sundry Alterations proposed unto us, we have rejected all such as were either of dangerous consequence (as secretly striking at some established Doctrine, or laudable Practice of the Church of *England*, or indeed of the whole Catholick Church of Christ) or else of no consequence at all, but utterly frivolous and vain. But such alterations as were tendered to us (by what persons, under what pretences, or to what purpose soever so tendered) as seemed to us in any degree requisite or expedient, we have willingly, and of our own accord assented unto: Not enforced so to do by any strength of Argument, convincing us of the necessity of making the said Alterations: For we are fully persuaded in our judgments (and we here profess it to the world) that the Book, as it stood before established by Law, doth not contain in it any thing contrary to the Word of God, or to sound Doctrine, or which a godly man may not with a good Conscience use and submit unto, or which is not fairly defensible against any that shall oppose the same; if it shall be allowed such just and favourable construction as in Common Equity ought to be allowed to all Human Writings, especially such as are set forth by Authority, and even to the very best Translations of the holy Scripture itself.

Our general aim therefore in this undertaking was, not to gratify this or that party in any their unreasonable demands; but to do that, which to our best understandings we conceived might most tend to the preservation of Peace and Unity in the Church; the procuring of Reverence, and exciting of Piety, and Devotion in the publick Worship of God; and the cutting off occasion from them that seek occasion of cavil or quarrel against the Liturgy of the Church. And as to the several variations from the former Book, whether by Alteration, Addition, or otherwise, it shall suffice to give this general account, That most of the Alterations were made, either first, for the better direction of

sion" was introduced at this time to indicate one or the other side of those who supported and those who opposed the Prayer Book.

In which review WE have endeavoured] This is the language of men who were sure of the ground, constitutional and ecclesiastical, upon which they were treading. They could speak as the Church of England, because the Convocations of Canterbury and York faithfully represented her.

Catholick Church of Christ] This is one of many places in which the position of the Church of England towards the Catholic Church is taken for granted as sound and firm. Another such has been pointed out already in the Title-page of the Prayer Book.

frivolous and vain] It is very remarkable to see how trifling these objections, *officially* made at the Savoy Conference, often were. One of them was to the reading of any part of the Burial Service at the grave, as the minister was sure to catch cold by doing so. The Bishops replied that a cap would remedy this inconvenience; and this was the reply given by the Dissenting Ministers: which, though long, is inserted as being very characteristic of the tone of the whole objections that were offered: "We marvel that you say nothing at all to our desire (that it be expressed in a Rubrick, that prayers and exhortations there used, be not for the benefit of the dead, but only for the instruction and comfort of the living). You intend to have a very indiscreet Ministry, if such a needless Circumstance may not be left to their discretion. The contrivance of a Cap instead of a Rubr. showeth that you are all unacquainted with the subject, of which you speak: and if you speak for want of experience of the case of souls, as you now do about the case of men's bodies, we could

wish you some of our experience of one sort (by more converse with all the members of the flock) though not of the other. But we would here put these three or four Questions to you.

"1. Whether such of ourselves as cannot stand still in the cold winter at the grave, half so long as the Office of Burial requireth, without the certain hazard of our lives (though while we are in motion we can stay out longer), are bound to believe your Lordships, that a Cap will cure this better than a Rubr., though we have proved the contrary to our cost? and know it as well as we know that cold is cold. Do you think no place but that which a cap or clothes do cover, is capable of letting in the excessively refrigerating air?"

"2. Whether a man that hath the most rational probability, if not a moral certainty, that it would be his death, or dangerous sickness (though he wore 20 caps) is bound to obey you in this case?"

"3. Whether usually the most studious, laborious ministers, be not the most invaletudinary and infirm? and

"4. Whether the health of such should be made a jest of, by the more healthful; and be made so light of, as to be cast away, rather than a ceremony sometime be left to their discretion? And whether it be a sign of the right and genuine spirit of Religion, to subject to such a ceremony, both the life of godliness, and the lives of ministers, and the people's souls? Much of this concerneth the people also, as well as the ministers."—*Grand Debate*, p. 145.

It is to be hoped the time can never return when such trifling and selfish arguments can be used on such a question.

them that are to officiate in any part of Divine Service ; which is chiefly done in the Kalendars and Rubricks : Or secondly, for the more proper expressing of some words or phrases of ancient usage in terms more suitable to the language of the present times, and the clearer explanation of some other words and phrases, that were either of doubtful signification, or otherwise liable to misconstruction : Or thirdly, for a more perfect rendering of such portions of holy Scripture, as are inserted into the Liturgy ; which, in the Epistles and Gospels especially, and in sundry other places, are now ordered to be read according to the last Translation : and that it was thought convenient, that some Prayers and Thanksgivings, fitted to special occasions, should be added in their due places ; particularly for those at Sea, together with an office for the Baptism of such as are of riper years : which, although not so necessary when the former Book was compiled, yet by the growth of Anabaptism, through the licentiousness of the late times crept in amongst us, is now become necessary, and may be always useful for the baptizing of Natives in our Plantations, and others converted to the Faith. If any man, who shall desire a more particular account of the several Alterations in any part of the Liturgy, shall take the pains to compare the present Book with the former ; we doubt not but the reason of the change may easily appear.

And having thus endeavoured to discharge our duties in this weighty affair, as in the sight of God, and to approve our sincerity therein (so far as lay in us) to the consciences of all men ; although we know it impossible (in such variety of apprehensions, humours, and interests, as are in the world) to please all ; nor can expect that men of factious, peevish, and perverse spirits should be satisfied with any thing that can be done in this kind by any other than themselves : Yet we have good hope, that what is here presented, and hath been by the Convocations of both Provinces with great diligence examined and approved, will be also well accepted and approved by all sober, peaceable, and truly conscientious sons of the Church of *England*.

the growth of Anabaptism] The effect of this upon the generation in which this Preface was written must have been very awful : and the necessity for the Service spoken of was strongly felt by the Convocation. In a work on the Bills of Mortality, written in 1665, there are some incidental remarks which strikingly corroborate those of this Preface : "The keeping of Parish Registers having been taken out of the hands of every Parish Minister, and committed to some inferior fellow elected by the people, and confirmed by the Justices of Peace, had been much neglected, and was again reduced into better order. And till this year the account of Christenings had been neglected more than that of Burials ; one and the chief cause whereof was a religious opinion against the baptizing of Infants, either as unlawful or unnecessary. If this were the only reason, we might, by our defects of this kind, conclude the growth of this opinion, and pronounce that not half the people of England between the years 1650 and 1660 were convinced of the need of baptizing. . . . Upon the whole matter it is most certain that the number of heterodox believers was very great between the said year 1650 and 1660, and so peevish were they as not to have the births of their children registered"¹ It may well

be believed that it was this privation of the grace of Baptism which led to such fearful profligacy and infidelity in the time of Charles II. and his immediate successors.

Convocations of both Provinces] For greater expedition in the work of revision certain Commissioners were appointed by the Convocation of York to sit in the Convocation of Canterbury as their representatives ; and thus was accomplished a selection of representatives from the whole body of the Church of England clergy.

The last words of this Preface contain an appeal to other times than those in and for which they were written. The safe path which was marked out so wisely by the Reformers has proved to be one which has approved itself to all subsequent generations, and it was the effort of the 1661 Revisers to walk in it faithfully, by returning, wherever they could, to the original English Prayer Book of 1549. Had they attempted to do this to a greater extent, there might have been danger of their whole work being set aside. Sobriety in wild and fanatical times, peace in a controversial age, and conscientiousness when so many were unscrupulous, were wise watchwords.

¹ Grant's Observations on the Bills of Mortality. 8vo. 1665.

CONCERNING THE SERVICE OF THE CHURCH.

A.D. 1549.]

THERE was never any thing by the wit of man so well devised, or so sure established, which, in continuance of time hath not been corrupted: As, among other things, it may plainly appear by the Common Prayers in the Church, commonly called *Divine Service*. The first original and ground whereof if a man would search out by the ancient Fathers, he shall find, that the same was not ordained but of a good purpose, and for a great advancement of godliness. For they so ordered the matter, that all the whole Bible (or the greatest part thereof), should be read over once every year; intending thereby, that the Clergy, and especially such as were Ministers in the congregation, should (by often reading, and meditation in God's word) be stirred up to godliness themselves, and be more able to exhort others by wholesome doctrine, and to confute them that were Adversaries to the Truth; and further, that the people (by daily hearing of holy Scripture read in the Church) might continually profit more and more in the knowledge of God, and be the more inflamed with the love of his true Religion.

But these many years passed, this godly and decent Order of the ancient Fathers hath been so altered, broken,

*Job viii. 8-10.
2f. p. 315, note 5,
'ex Pa-
rum'*

* * * * *

NIHIL enim humano elaboratum ingenio, tam exactum initio unquam fuit, quin postea, multorum accedente judicio, perfectius reddi possit, ut in ipsis etiam ecclesiasticis institutis circa primitivam præsertim ecclesiam contigisse videmus.

Preface of Cardinal Quignonez' Reformed Roman Breviary, 1535-7.

* * * * *

Et profecto si quis modum precandi olim a majoribus traditum diligenter consideret, plane intelligat horum omnium præcipuam ab ipsis habitam esse rationem.

* * * * *

Tertia, ut religionis quoque futuri magistri quotidiana sacræ scripturæ et ecclesiasticarum historiarum lectione erudiantur, complectanturque (ut Paulus ait) eum, qui secundum doctrinam est, fidelem sermonem, et potentes sint exhortari in doctrina sana, et eos, qui contradicunt, arguere.

* * * * *

Sed factum est nescio quo pacto precantium negligentia, ut paulatim a sanctissimis illis veterum patrum in-

This explanatory introduction is the original Preface of the Prayer Book, and is supposed to have been written by Cranmer. It was moved to this place when the present Preface was inserted in 1661. Two short sentences were also erased.

By whomsoever it was written, there can be no doubt that it was composed with the Reformed Roman Breviary of Quignonez lying open before the writer. The passages in the right-hand column are, with two exceptions, taken from an edition of 1537, belonging to Queen's College, Oxford, and the preface to this edition agrees with all the later copies. But the Paris edition of 1536 (probably following the Roman one of 1535) differs considerably¹. Our English Preface is most like the later edition of Quignonez; but the paragraph enclosed in brackets appears to show that the earlier one was also known to the Reformers of our Services. There are six copies of this Breviary in the Bodleian Library, one at the British Museum, one at the Routh

¹ The writer has not been able to meet with this, but copies from Guenger's *Institutions Liturgiques*, p. 398.

Library of Durham University, one in the Public Library at Cambridge, and one in Queen's College, Oxford; but none of these are earlier than 1537. Others are in private hands.

It has already been mentioned, in the Historical Introduction (p. xx), that this Reformed Roman Breviary exercised some influence upon the reformed English offices. It set us the example of compression in the services, and also of method. Quignonez removed the ancient Confession and Absolution to the beginning of the daily services, and in this too he was followed by our Reformers. His Breviary, again, established a system of two lessons on ordinary, or ferial days; the first of which was taken from the Old Testament, and the second from the New Testament. On festivals, a third lesson was added, which was generally a short passage from a homily of St. Gregory or some other patristic author. The two former were seldom entire chapters, but were taken in a regular succession, like our own daily lessons. In some respects the changes made by Cardinal Quignonez, and sanctioned by Paul III. in a Papal bull, were more sweeping in their character than those of our own reform. It is evident from

and neglected, by planting in uncertain Stories, and Legends, with multitude of Responds, Verses, vain Repetitions, Commemorations, and Synodals; that commonly when any Book of the Bible was begun, after three or four Chapters were read out, all the rest were unread. And in this sort the Book of *Isaiah* was begun in *Advent*, and the Book of *Genesis* in *Septuagesima*; but they were only begun, and never read through: After like sort were other Books of holy Scripture used. And

1 Cor. xiv. 2—19. moreover, whereas St. Paul would have such language spoken to the people in the Church, as they might understand, and have profit by hearing the same; The Service in this Church of *England* these many years, hath been read in Latin to the people, which they understand not; so that they have heard with their ears only, and their heart, spirit, and mind, have not been edified thereby. And furthermore, notwithstanding that the ancient Fathers have divided the *Psalms* into seven Portions, whereof every one was called a *Nocturn*: Now of late time a few of them have been daily said, and the rest utterly omitted. Moreover, the number and hardness of the Rules called the *Pie*, and the manifold chang-

Cf. p. xxiii.

See p. 314.

stitutis discederetur. Nam libri Scripturæ sacræ, qui statis annis temporibus legendi erant more majorum vix dum incepti omittuntur in alio breviario. Tum historiæ sanctorum quædam tam incultæ, et tam sine delectu scriptæ habentur in eodem, ut nec auctoritatem habere videantur nec gravitatem. [Ut exemplo esse possunt liber Genesis, qui incipitur in Septuagesima, liber Isaïæ, qui in Adventu, quorum vix singula capitula perlegimus: ac eodem modo cetera Veteris Testamenti volumina degustamus magis quam legimus. Nec secus accidit in Evangelia, et reliquam Scripturam Novi Testamenti, quorum in loco successerunt alia, nec utilitate cum his, nec gravitate comparanda, quæ quotidie agitatione linguæ magis quam intentione mentis inculcantur.]

* * * * *

. . . . et psalmorum plerisque omissis, pauci singulis fere diebus repeterentur.

* * * * *

Accedit tam perplexus ordo, tamque difficilis precandi ratio, ut interdum

his preface that others, beside himself, were engaged on the work of revision; and this, as well as the long time occupied over it, offers another point of comparison between the two reformed service-books, those of Rome and England.

more majorum] Later on occur also the following words: "Ac illud ante omnia visum nobis est in consuetudinem revocare, ut Scriptura Sacra maxime omnium toto anno, et omnes psalmi singulis septimanis perlegerentur."

Ut exemplo] This passage is in the earlier edition of 1536, but not in that from which the rest is quoted. The writer has been obliged to quote it from Guerauger, not being able to meet with this edition in England.

Responds] These were short anthems, similar to that which is ten times sung during the reading of the passage of Scripture which contains the Ten Commandments. Theoretically they gave the key-note of the Lesson; but this principle was often deviated from, and the sense was frequently broken up rather than illustrated. The practice, in moderation, is a very excellent one¹.

Verses] Versicles, a short form of respond.

vain Repetitions] See Historical Introduction, p. xxvii.

Commemorations] Anthems commemorative of festivals.

Synodals] The provincial constitutions or canons which were read in parish churches after the conclusion of synods. The reading of them after the lessons was probably the origin of the corresponding custom of giving out notices after the Second Lesson.

¹ See p. 11, where the 9th Respond for Festivals in Advent is given in a note.

the Pie] The following is exactly one-third of the *Pica* or *Pie* for a single Sunday, the first of Advent. Maskell observes that it was not possible for the same service to occur on the same Sunday of the year twice running; and it will be seen that Quignonez and our Reformers did not overstate the case in respect to the complexity of this ancient rule. In York Minster Library there is a volume containing the *Pie* only.

"*Pica* de Dominica Prima Adventus.

"LITERA DOMINICALIS A.—Tertia Decembris tota cantetur Historia *Aspiciens*. Secundæ Vesperæ erunt de Sancto Osmundo, cum pleno servitio in crastino; et solennis memoria de octava, et de Dominica, et de Sancta Maria cum antiphona *Ave Maria*.—Feria 2 de S. Osmundo: ix. lectiones: omnia de Comuni unius Confessoris et Pontificis. Sec. vesp. erunt de commemoratione, et mem. de Sancto, de octava, de Adventu, et de S. Maria, cum ant. *Ave Maria*.—Feria 3, 5, et sabbato, de commemorationibus, et Responsoria ferialia prætermittantur; et Missa de oct. S. Andreae dicitur in capitulo.

"LIT. DOM. B.—Quinto Cal. Dec. tota cantetur hist. *Aspiciens*, et mem. de S. Maria.—Fer. 2, 6, et sabb. de commem.—Fer. 3 de feria, et nihil de martyribus nisi mem. ad vesp. et ad matutinas de S. Maria. Missa de vigilia.—Fer. 4. de Apostolo, et solen. mem. de Adv. et de S. Maria.—Fer. 5 de fer. cum Resp. ferialibus, et mem. de oct. et Missa de 4 fer." And so on, through the seven Sunday Letters.

It was, perhaps, from the confused appearance which a page of *Pica* presents that printers came to call any portion of type

ings of the Service was the cause, that to turn the Book only was so hard and intricate a matter, that many times there was more business to find out what should be read, than to read it when it was found out.

These inconveniences therefore considered, here is set forth such an Order, whereby the same shall be redressed. And for a readiness in this matter, here is drawn out a Kalendar for that purpose, which is plain and easy to be understood; wherein (so much as may be) the reading of holy Scripture is so set forth, that all things shall be done in order, without breaking one piece from another. For this cause be cut off Anthems, Responds, Invitatories, and such like things as did break the continual course of the reading of the Scripture.

Yet, because there is no remedy, but that of necessity there must be some Rules; therefore certain Rules are here set forth; which, as they are few in number, so they are plain and easy to be understood. So that here you have an Order for Prayer, and for the reading of the holy Scripture, much agreeable to the mind and purpose of the old Fathers, and a great deal more profitable and commodious, than that which of late was used. It is more profitable, because here are left out many things, whereof some are untrue, some uncertain, some vain and superstitious; and nothing is ordained to be read, but the very pure Word of God, the holy Scriptures, or that which is agreeable to the same; and that in such a language and order as is most easy and plain for the understanding both of the readers and hearers. It is also more commodious, both for the shortness thereof, and for the plainness of the Order, and for that the Rules be few and easy.

See p. [15, margin.

paulo minor opera in requirendo ponatur, quam, cum inveneris, in legendo.

* * * * *

Versiculos, responsoria, et capitula omittere idcirco visum est . . . et legentes sæpe morentur cum molestia quæritandi, locum relinqui volumus continenti lectioni Scripturæ Sacræ . . .

* * * * *

Habet igitur hæc precandi ratio tres maximas commoditates. Primam, quod precantibus simul acquiritur utriusque Testamenti peritia. Secundum, quod res est expeditissima propter summam ordinis simplicitatem et nonnullam brevitem. Tertiam, quod historiæ sanctorum nihil habeant, ut prius quod graves, et doctas aures offendat.

* * * * *

quasdam omisimus illis nec probabilitate nec gravitate pares . . .

which is in utter disorder through accident or otherwise by the name of "pic." The ecclesiastical use of the word is thought to have been derived from *πίναξ*, an index, or table, from the wooden boards on which the directions for service were written out in primitive days. It is identical with "ordinale" and with "Directorium sacerdotum." The "Pica" type of later days took its name from the large letters in which the pica of the Anglican Portiforia was printed.

[few and easy] The following passage was omitted from the

Preface at the last revision:—"Furthermore, by this order the Curates shall need none other books for their public service, but this book and the Bible. By the means whereof, the people shall not be at so great charges for books as in times past they have been." It was crossed out by Bishop Cosin; not, probably, from any idea that the passage was an unworthy one, but because it was so entirely out of date when the press had made the advance it had in 1661. Although, moreover, the passage was applicable to the case of poor parish churches, it was not so in that of richer

And whereas heretofore there hath been great diversity in saying and singing in Churches within this Realm; some following *Salisbury* Use, some *Hereford* Use, and some the Use of *Bangor*, some of *York*, some of *Lincoln*; now from henceforth all the whole Realm shall have but one Use.

And forasmuch, as nothing can be so plainly set forth, but doubts may arise in the use and practice of the same; to appease all such diversity (if any arise) and for the resolution of all doubts, concerning the manner how to understand, do, and execute, the things contained in this Book; the parties that so doubt, or diversely take any thing, shall always resort to the Bishop of the Diocese, who by his discretion shall take order for the quieting and appeasing of the same; so that the same order be not contrary to any thing contained in this Book. And if the Bishop of the Diocese be in doubt, then he may send for the resolution thereof to the Archbishop.

THOUGH it be appointed, That all things shall be read and sung in the Church in the *English* Tongue, to the end, that the congregation may be thereby edified; yet it is not meant, but that when men say Morning and Evening Prayer privately, they may say the same in any language that they themselves do understand.

ones and cathedrals, where as many books as formerly are required for the use of the choirs. There are practically in use by most of the clergy and choirs in one or other class of Churches, separate Breviaries, Missals, Manuals, Antiphonaries, "Service"-books, Psalters, and Lectionaries; the whole volume of the Holy Bible being now used for the latter, instead of those parts only which are needed for the daily and proper Lessons.

but one Use] Another part of the Preface erased by Cosin was this; and it seems to have been suggested by a passage in that of Quignonez :

And if any will judge this way more painful, because that all things must be read upon the Book, whereas before, by the reason of so often repetition they could say many things by heart: if those men will weigh their labour, with the profit and knowledge which daily they shall obtain by reading upon the book, they will not refuse the pain, in consideration of the great profit that shall ensue thereof.

Si cui autem in hoc Breviario laboriosum videbitur pleraque omnia ex libro legi, cum multa in alio quæ propter frequentem repetitionem ediscuntur memoriter pronuntientur, compenset cum hoc labore cognitionem Scripturæ Sacræ, quæ sic indies augetur; et intentionem animæ, quam Deus ante omnia in precantibus requirit: hanc enim majorem legentibus, quam memoriter prosequentibus adesse necesse est: et hujusmodi laborem non modo fructuosum, sed etiam salutarem indicabit.

shall resort to the Bishop] There is no power here given to

the Bishop of the Diocese to deviate from the rules laid down in the Book of Common Prayer. He is the administrator, not the maker, of the ritual law of the Church.

THE LATIN PRAYER BOOK¹.

In the first Act of Uniformity (2 & 3 Edward VI. c. 1), the fifth clause was as follows: "Provided always that it shall be lawful to any man that understandeth the Greek, Latin, and Hebrew tongue, or other strange tongue, to say and have the said prayers heretofore specified of Matins and Evensong in Latin or any such other tongue, saying the same privately as they do understand. And for the further encouraging of learning in the tongues in the Universities of Cambridge and Oxford, to use and exercise in their common and open prayer in their Chapels, being no Churches or other places of Prayer, the Matins, Evensong, Litany, and all other prayers, the Holy Communion, commonly called the Mass, excepted, in the said book prescribed in Greek, Latin, or Hebrew; any thing in this present Act to the contrary notwithstanding."

In the Act of Uniformity at present in force (14 Car. II.), this clause is also enacted: "Provided always, That it shall and may be lawful to use the Morning and Evening Prayer, and all other Prayers and Service prescribed in and by the said book, in the Chapels or other Publick Places of the respective Colleges and

¹ A Greek version was printed in 1573.

And all Priests and Deacons are to say daily the Morning and Evening Prayer, either privately or openly, not being let^d by sickness, or some other urgent cause.

And the Curate that ministereth in every Parish-Church or Chapel, being at home, and not being otherwise reasonably hindered, shall say the same in the Parish-Church or Chapel where he ministereth, and shall cause a Bell to be tolled thereunto a convenient time before he begin, that the people may come to hear God's Word, and to pray with him.

Halls in both the Universities, in the Colledges of *Westminster*, *Winchester*, and *Eaton*, and in the Convocations of the Clergies of either Province in Latine; Any thing in this Act contained to the contrary notwithstanding."

Letters patent were issued by Queen Elizabeth to the same effect, and printed at the beginning of the Latin Prayer Book issued by her authority in 1560; there being no limitation (as there is not in the present Act of Uniformity) with respect to the Communion Service¹. Bishop Cosin added to the existing rule the words "especially in the Colleges and Halls of either University, and in the Schools of Westminster, Eaton, and Winchester," but the alteration was not printed, though not erased by the Committee of Revision.

The first Latin Version of the Book of Common Prayer was made in 1551 by a former Canon of St. Andrew's, Edinburgh, named Alexander Aless, and under the direction of Archbishop Cranmer². As some provision would certainly be made by authority for carrying out the proviso of the Act of Uniformity, it is probable that the translation of Aless was made for this purpose; although, because Cranmer used it for giving Martin Bucer a knowledge of the English formularies, it is commonly said that he had it done expressly for that object. Bucer in his *Censura* distinctly says "librum istum Sacrorum, per interpretem, quantum potui, cognovi diligenter;" and a comparison of dates makes it almost certain that he gained what little knowledge he there had of our English services through an *oral* interpretation, before he received the copy of Aless' version from Cranmer. But Aless was now a professor in a Lutheran, that is, a Presbyterian, University; and his Latin version is very far from being rendered with that *bona fides* so ostentatiously put forth on the title-page.

This version was, however, the foundation of that issued by Queen Elizabeth in 1560, having been revised by Walter Haddon³. But Queen Elizabeth's Latin Prayer Book differs considerably from her English one; and although, in many respects, it better represents the original Prayer Book of 1549, it can hardly be taken as having authority under our present Act of Uniformity. In addition to the ordinary services, there were also added to this Latin version an Office, "*In commendationibus Benefactorum*," and another, "*Celebratio cenae Domini, in funebribus, si amici et vicini defuncti communicare velint*." These two offices were specially mentioned as "*peculiaria quedam*" in the Letters Patent. The book was reprinted in 1574 and in 1596, and is to be found in a modern reprint among the Parker Society's publications; and no doubt it was adopted for the private recitation of the Daily Offices in days when Latin was more freely used

¹ An authorized French translation was printed by Archbishop Cranmer's order in 1552. In a letter to Secretary Cecil (Styrye's Memorials, iii. 698, Eccl. Hist. Soc.) the Archbishop says that this was first done by Sir Hugh Paulet's commandment (who was Governor of Calais), and overseen by the Lord Chancellor (Goodrich, Bishop of Ely), and others, being afterwards revised by a learned Frenchman who was a Doctor of Divinity. This revision was for the second book of Edward VI., and was printed in 1553.

² *Oratio Ecclesie, seu Ministerii Ecclesiastici, in florentissimo Regno Anglie, conscripta sermone patrio, et in Latinam linguam bona fide conversa, et ad consolationem Ecclesiarum Christi, ubicunque locorum agentium, his tristissimis temporibus, edita ab Alexandro Alessio, Scoto, Sacre Theologie Doctore. Lipsie. MDLI.*

³ *Liber Precum Publicarum, seu Ministerii Ecclesiastice administrationis Sacramentorum, aliorumque rituum & ceremoniarum in Ecclesia Anglicana. Cum privilegio Regie Majestatis.*

than it has been in later times. These words are to be found at the close of the Letters Patent: "*Eadem etiam formula Latina precandi privatim uti hortamur omnes reliquos Ecclesie nostre Anglicane ministros, cujuscunque gradus fuerint, us diebus, quibus aut non solent, aut non tenentur parochianis suis, eadem sacram pro more accedentibus, publice preces vernacula lingua, secundum formam dicti Statuti, recitare.*" Which exhortation may be taken as a contemporary interpretation of the clause to which this note refers.

The Daily Services, the Psalter, and some additional Collects and Prayers were translated into Latin for the use of Christ Church, Oxford, in 1660⁴. But this is not a complete version of the Book of Common Prayer.

A Latin Version, which is by far the most complete and exact that has ever been produced, was printed by Messrs. Rivington in 1865. In this, the ancient and original Latin phraseology is adopted wherever it can be traced, and the more recent portions are rendered into Latin of a similar character⁵.

PRIVATE RECITATION OF THE SERVICES BY THE CLERGY.

The second paragraph of the above Appendix to the Preface of 1549 enjoins the Clergy to say the Daily Offices constantly either privately or openly, unless hindered by some urgent cause. This direction has undergone the following changes:—

1549.	1552.	1661.
Neither that any man shall be bound to the saying of them, but such as from time to time, in Cathedral and Collegiate churches, parish churches, and chapels to the same annexed, shall serve the congregation.	And all priests and deacons shall be bound to say daily the Morning and Evening Prayer, either privately or openly, except they by sickness, or some other urgent cause.	And all priests and deacons are to say daily the Morning and Evening Prayer, either privately or openly, not being let by sickness, or some other urgent cause.

In the Scotch Prayer Book of 1637 the words were added, "of which cause, if it be frequently pretended, they are to make the bishop of the diocese, or the archbishop of the province, the judge and allower." Bishop Cosin also added to "urgent cause," "which the Bishop of the Diocese shall approve." But the present form appears to be that which he ultimately adopted, and that which was accepted by the Committee of Revision.

This rule was regarded by Bishop Cosin, as he tells us in his notes to the Prayer Book [Works, vol. v. p. 9] as a continuation of the ancient rule of the unreformed Church: and such has been the opinion of most sound writers since his time. The Letters Patent attached to the Latin Prayer Book of Queen Elizabeth confirm this view; and so also does the practice of many holy clergymen at every period since the Reformation. The principle of it is that the Clergy are bound to offer the

⁴ *Liber Precum Publicarum in Usam Ecclesie Cathedralis Christi Oxon. Oxoniae. 1660.*

⁵ *Libri Precum Publicarum Ecclesie Anglicane Versio Latina. A Gulielmo Bright, A.M., et Petro Goldsmith Medd, A.M. Presbyteris, Collegii Universitatis in Acad. Oxon. Sociis, Facta. Apud Rivington, Londini, Oxoni, Cantabrigiæ. 1865.*

OF CEREMONIES,

WHY SOME BE ABOLISHED, AND SOME RETAINED.

OF such Ceremonies as be used in the Church, and have had their beginning by the institution of man, some at the first were of godly intent and purpose devised, and yet at length turned to vanity and superstition:

prayers of the Church daily to the glory of God, and as intercessors for their flocks, whether any come to join them in the offering or not. Such private recitation of the daily offices is, however, only to be used when the better way of "open prayer" with a congregation cannot be adopted.

DAILY MORNING AND EVENING PRAYER.

The third paragraph of the above rule very clearly enjoins the use of Daily Service. Bishop Cosin wished to define the hours at which it was to be said within certain limits, by adding to "a convenient time before he begin,"—"which may be any hour between six and ten of the clock in the morning, or between two and six of the clock in the evening:" and although his alteration was not adopted, it serves to show us what were then considered the canonical limits of the times for Mattins and Evensong.

The Laity should never allow their Clergy to find the House of God empty when they go there to carry out this most excellent rule of the Church. In the fifteenth Canon, which directs "the Litany to be read on Wednesdays and Fridays," there is an injunction which shows in what manner the practice of Daily Service ought to be kept up by the Laity as well as the Clergy: "The minister, at the accustomed hours of service, shall resort to the Church and Chapel, and, warning being given to the people by tolling of a bell, shall say the Litany prescribed in the Book of Common Prayer; wherunto we wish every householder dwelling within half-a-mile of the Church to come, or send one at the least of his household, fit to join with the Minister in prayers." It was undoubtedly the intention of the first Reformers, and of all who, at any time, revised our Services, to have them used daily, Morning and Evening, openly in the Church, by the Clergy and as many of the Laity as may be able to attend. Many endowments have been left for assisting to carry out this intention of the Church; and the practice has been kept up in some parish Churches (as well as in the Cathedrals) without any break, except during the persecution of the 17th century. In 1724, when the population of London was only one-sixth of what it is at the present time, there were seventy-five churches open daily for Divine Service; and there are many proofs that the same diligence in prayer was used in the country as well as in large cities.

Such continual public acts of Divine Worship are expedient for various reasons. (1) It is due to the honour of Almighty God that the Church in every place consecrated to His service should begin and end the day by rendering Him a service of praise. (2) Each Church and parish being a corporate centre and corporate whole, prayer for God's grace and His mercy should be offered morning and evening, for the body, which the Church and such congregation as can assemble represents. Thus the Divine Presence is drawn down to the Tabernacle that It may thence sanctify the whole Camp. (3) The benefit to the Clergy is very great, of offering Divine Worship, prayer, and intercession, in the presence of, and in company with, some of their flock. (4) There are advantages to those who frequently join in Divine Service which can only be fully known by experience, but which will then be appreciated as blessings not otherwise to be obtained. (5) The service of the Sanctuary is the most real and true form of that daily Morning and Evening worship for which Family prayer has been originated as an imperfect substitute; for it is the true Common Prayer (see p. 2) of the Church

offered in the Name of Christ by two or three gathered together under His authority, and according to His ordinance.

It may be noticed that the Act of Uniformity enjoins that the Common Prayer shall be said on Sundays and Holy Days, and on all other Days; and that the title of our Morning and Evening Service is, "The Order for Morning or Evening Prayer DAILY throughout the year." In the beginning of the "Form of Prayer to be used at Sea," there is also this rubric, "¶ The Morning and Evening Service to be used daily at Sea, shall be the same which is appointed in the Book of Common Prayer." And the next rubric is, "These two following Prayers are to be also said in Her Majesty's Navy every day."

OF CEREMONIES.

This justification of the course taken at the Reformation with respect to the Ceremonial part of Divine Worship is probably written by Archbishop Cranmer, being included in some early lists of his works. It was originally inserted at the end of the Prayer Book, and was followed by some ritual directions reprinted below. In 1552, the part "Of Ceremonies" was placed after the Preface, and these ritual directions were omitted.

"Certain Notes for the more plain Explication and decent Ministration of Things contained in this Book."

"In the saying or singing of Matins and Evensong, baptizing and burying, the Minister, in parish churches and chapels annexed to the same, shall use a surplice. And in all cathedral churches and colleges, the Archdeacons, Deans, Provosts, Masters, Prebendaries, and Fellows, being Graduates, may use in the quire, beside their surplices, such hood as pertaineth to their several degrees, which they have taken in any university within this realm. But in all other places, every minister shall be at liberty to use any surplice or no. It is also seemly, that Graduates, when they do preach, should use such hoods as pertaineth to their several degrees.

"¶ And whensoever the Bishop shall celebrate the holy Communion in the church, or execute any other public ministration, he shall have upon him, beside his rochette, a surplice or albe, and a cope or vestment; and also his pastoral staff in his hand, or else borne or holden by his chaplain.

"¶ As touching kneeling, crossing, holding up of hands, knocking upon the breast, and other gestures, they may be used or left, as every man's devotion serveth, without blame.

"¶ Also upon Christmas Day, Easter Day, the Ascension Day, Whit-Sunday, and the feast of the Trinity, may be used any part of Holy Scripture hereafter to be certainly limited and appointed, in the stead of the Litany.

"¶ If there be a sermon, or for other great cause, the Curate, by his discretion, may leave out the Litany, Gloria in Excelsis¹,

¹ The omission of this is not quite so strange as it seems at first: "Ab Adventu Domini usque ad Nativitatem ejus [ab Septuagesima usque in Cenam Domini, cap. xlviil.], Te Deum Laudamus, Gloria in Excelsis Deo, Ite missa est, dimittimus, quia major gloria Novi Testamenti, quam Veteris, ejus typum infra Adventum Domini observamus." Micrologus de Ecc. Observat. cap. xxx. It was likewise omitted in Septuagesima and on Innocents' Day. There was also a limitation of its use on Palm Sunday, "in Ecclesiis in quibus chrisma conficitur, et non in aliis" [Durand. Ration. div. off. vi. 75. 2]: and one of the first rubrics in the Sacramentary of St. Gregory is, "Quando vero Litaniam agit, neque Gloria in Excelsis Deo, neque Alleluia canitur."

Some entered into the Church by indiscreet devotion, and such a zeal as was without knowledge; and for because they were winked at in the beginning, they grew daily to more and more abuses, which not only for their unprofitableness, but also because they have much blinded the people, and obscured the glory of God, are worthy to be cut away, and clean rejected: Other there be, which although they have been devised by man, yet it is thought good to reserve them still, as well for a decent order in the Church (for the which they were first devised), as because they pertain to edification, whereunto all things done in the Church (as the Apostle teacheth) ought to be referred.

And although the keeping or omitting of a Ceremony, in itself considered, is but a small thing; yet the wilful and contemptuous transgression and breaking of a common order and discipline is no small offence before God. *Let all things be done among you,* saith St. Paul, *in a seemly and due order:* The appointment of the which order pertaineth not to private men; therefore no man ought to take in hand, or presume to appoint or alter any publick or common Order in Christ's Church, except he be lawfully called and authorized thereunto.

And whereas in this our time, the minds of men are so diverse, that some think it a great matter of conscience to depart from a piece of the least of their Ceremonies, they be so addicted to their old customs; and again on the other side, some be so new-fangled, that they would innovate all things, and so despise the old, that nothing can like them, but that is new: It was thought expedient, not so much to have respect how to please and satisfy either of these parties, as how to please God, and profit them both. And yet lest any man should be offended, whom good reason might satisfy, here be certain causes rendered, why some of the accustomed Ceremonies be put away, and some retained and kept still.

Some are put away, because the great excess and multitude of them hath so increased in these latter days, that the burden of them was intolerable; whereof St. *Augustine* in his time complained, that they were grown to such a number, that the estate of Christian people was in worse case concerning that matter, than were the Jews. And he counselled, that such yoke and burden should be taken away, as time would serve quietly to do it. But what would St. *Augustine* have said, if he had seen the Ceremonies of

the Creed, the Homily, and the Exhortation to the Communion."

There was a rubric printed at the beginning of the Communion Service relating to the same subject: and as all three documents are of the same date (A.D. 1549), it also is here reprinted, so as to bring them under one view:

"¶ Upon the day, and at the time appointed for the ministration of the holy Communion, the Priest that shall execute the holy ministry, shall put upon him the vesture appointed for that ministration, that is to say, a white albe plain, with a vestment or cope. And where there be many Priests or Deacons, there so many shall be ready to help the priest in the ministration, as shall be requisite; and shall have upon them likewise the vestures appointed for their ministry, that is to say, albes with tunicles."

The subject of Ceremonies being dealt with at large in the Ritual Introduction, it is not necessary to go into much detail respecting this document; but a few notes are annexed pointing out the principles which actuated the Reformers of 1549 as they are indicated in their explanation or apology.

institution of man] The distinction implied in these words shows that Archbishop Cranmer and his associates did not consider themselves at liberty to alter any ceremonies of Divine Institution, such as the Laying on of Hands, or the breaking of the Bread in the Consecration of the Holy Eucharist.

turned to vanity and superstition] The primitive love-feasts

and the kiss of peace are illustrations of this assertion; so also is the excessive use of the sign of the Cross, which provoked a recoil equally superstitious, leading to the disuse of it altogether.

Some entered . . . by indiscreet devotion] Of such a kind were the ceremonies connected with images, and even with relics. These ceremonies were prompted, in the first instances, by the best of feelings; but, in the course of time, they became perverted into usages which can hardly be distinguished from idolatry, and thus "obscured the glory of God¹" instead of presenting it more clearly to the eyes of His worshippers.

Some are put away, because the great excess] The minute directions given in the rubrics of the old Service-books often occupy page after page, while the prayers to which they are annexed occupy only a few lines; and it must be a matter of grave doubt, whether any more than a small fraction of the ceremonies latterly used in the celebration of the Holy Eucharist were intelligible to any but experienced priests. Their excess had become insupportable both to the clergy and the people, and the meaning of many had quite passed away. Nor is there any reason to doubt the assertion that many ceremonies were so abused through ignorance on the one hand, and corruption on the other, "that the abuses could not well be taken away, the thing remaining still;" a state of things had in fact grown up

¹ Aug. Ep. 55 ad Januarium, c. xix. § 35 (al. Ep. 112)

late days used among us; whereunto the multitude used in his time was not to be compared? This our excessive multitude of Ceremonies was so great, and many of them so dark, that they did more confound and darken, than declare and set forth Christ's benefits unto us. And besides this, Christ's Gospel is not a Ceremonial Law (as much of *Moses' Law* was), but it is a Religion to serve God, not in bondage of the figure or shadow, but in the freedom of the spirit; being content only with those Ceremonies which do serve to a decent Order, and godly Discipline, and such as be apt to stir up the dull mind of man to the remembrance of his duty to God, by some notable and special signification, whereby he might be edified. Furthermore, the most weighty cause of the abolishment of certain Ceremonies was, That they were so far abused, partly by the superstitious blindness of the rude and unlearned, and partly by the unsatiable avarice of such as sought more their own lucre, than the glory of God, that the abuses could not well be taken away, the thing remaining still.

But now as concerning those persons, which peradventure will be offended, for that some of the old Ceremonies are retained still: If they consider that without some Ceremonies it is not possible to keep any Order, or quiet Discipline in the Church, they shall easily perceive just cause to reform their judgments. And if they think much, that any of the old do remain, and would rather have all devised

anew: Then such men granting some Ceremonies convenient to be had, surely where the old may be well used, there they cannot reasonably reprove the old only for their age, without bewraying of their own folly. For in such a case they ought rather to have reverence unto them for their antiquity, if they will declare themselves to be more studious of unity and concord, than of innovations and new-fangleness, which (as much as may be with true setting forth of Christ's Religion) is always to be eschewed. Furthermore, such shall have no just cause with the Ceremonies reserved to be offended. For as those be taken away which were most abused, and did burden mens consciences without any cause; so the other that remain, are retained for a Discipline and Order, which (upon just causes) may be altered and changed; and therefore are not to be esteemed equal with God's Law. And moreover, they be neither dark nor dumb Ceremonies, but are so set forth, that every man may understand what they do mean, and to what use they do serve. So that it is not like that they in time to come should be abused as other have been. And in these our doings we condemn no other Nations, nor prescribe any thing but to our own people only: For we think it convenient, that every Country should use such Ceremonies as they shall think best to the setting forth of God's honour and glory, and to the reducing of the people to a most perfect and godly living, without error or superstition; and that they should put away other

which required strong measures for its reformation: a state of things moreover, to which the present age can never offer a parallel; since, although it is possible to conceive of a great increase in the ceremonies used by the Church, that increase could never again be accompanied by the same ignorance.

But now as concerning those persons] Extreme and superstitious opinions against ceremonies were beginning to be as great a trouble to the Church as the extravagant and superstitious use of them had been. The principles here enunciated against the enthusiasts who held them are: (1) That some ceremonies are absolutely essential to the order and decency of divine Service. (2) That to invent new ones altogether would be as presumptuous as unnecessary. (3) That the old ones which were retained under the new system of the Church of England were of an edifying kind. (4) That the ceremonies retained

were never likely to be abused as those which were set aside had been.

we condemn no other Nations] This excellent sentence strongly illustrates the temperate spirit in which the official work of the Reformation of the Church of England was conducted. Recognizing the right which a national Church possessed to make such changes as may be expedient (subject to the retention of Catholic essentials), the Reformers acted upon it; but they also recognized it for other Churches as well as for that of England, and claimed to be the advocates of change and reconstruction only within the bounds of their legitimate jurisdiction. So sound a principle deserves the highest respect, and should be acted upon at all times. Had it been adhered to by the foreign party as well as by the official guides of the Reformation, a great schism would have been prevented.

things, which from time to time they perceive to be most abused, as in mens ordinances it often chanceth diversely in divers countries.

THE ORDER

HOW THE PSALTER IS APPOINTED TO BE READ.

THE Psalter shall be read through once every Month, as it is there appointed, both for Morning and Evening Prayer. But in *February* it shall be read only to the Twenty-eighth, or Twenty-ninth day of the Month.

And, whereas *January, March, May, July, August, October, and December*, have One-and-thirty days apiece; It is ordered, that the same Psalms shall be read the last day of the said months, which were read the day before: So that the Psalter may begin again the first day of the next month ensuing.

And, whereas the cixith Psalm is divided into xxii Portions, and is over long to be read at one time; It is so ordered, that at one time shall not be read above four or five of the said Portions.

And at the end of every Psalm, and of every such part of the cixith Psalm, shall be repeated this Hymn,

Glory be to the Father, and to the Son: and to the Holy Ghost;

As it was in the beginning, is now, and ever shall be: world without end. Amen.

Note, That the Psalter followeth the Division of the Hebrews, and the Translation of the Great English Bible, set forth and used in the time of King *Henry the Eighth*, and *Edward the Sixth*.

THE ORDER

HOW THE REST OF HOLY SCRIPTURE IS APPOINTED TO BE READ.

THE Old Testament is appointed for the first Lessons at Morning and Evening Prayer; so as the most part thereof will be read every year once, as in the Kalendar is appointed.

The New Testament is appointed for the second Lessons at Morning and Evening Prayer, and shall be read over orderly every year thrice, besides the Epistles and Gospels; except the Apo-

diversely in divers countries] No doubt there are many Ceremonies used in the Eastern Church, and in southern countries of Europe, which seem unprofitable, and even worse, to persons brought up under a different system, and under different circumstances: but to those who use them they may be a true vehicle of adoration as regards Him Whom they worship, and of wholesome religious emotion as respects themselves.

THE PSALTER.

Full notes on the Psalter will be found in the Introduction to the Psalter, pp. 313—317.

THE LESSONS.

The old system of the Church of England, in respect to the reading of Holy Scripture in Divine Service, was very similar

throughout all the offices in which it was read, to that now retained only in the Communion Service. Short selections were made from different books of the Holy Bible, and these were read successively (sometimes three, and at others nine), "responsively," or short anthems (intended to answer in character to the Lesson read), being sung after each. But the whole of the Lessons of the day were rarely taken from Holy Scripture, some being usually extracts from Patristic writings, or the Lives of Saints.

The responsory system of reading Holy Scripture is still retained in its old form in the case of the Ten Commandments when said at the Communion Service: but one of the principal changes made in 1549, was the substitution for it of longer and continuous lessons,—generally whole chapters,—with responsory Canticles, sung at the end only. No doubt this was a return to ancient practice, as it is said to be in the original preface to the

PROPER LESSONS

calypse, out of which there are only certain proper Lessons appointed upon divers Feasts.

And to know what Lessons shall be read every day, look for the day of the Month in the Kalendar following, and there ye shall find the Chapters that shall be read for the Lessons both at Morning and Evening Prayer; Except only the Moveable Feasts, which are not in the Kalendar, and the Immove-

able, where there is a blank left in the Column of Lessons; the proper Lessons, for all which days are to be found in the Table of proper Lessons.

And note, That whensoever proper Psalms or Lessons are appointed; then the Psalms and Lessons of ordinary course appointed in the Psalter and Kalendar (if they be different) shall be omitted for that time.

Note also, that the Collect, Epistle, and Gospel appointed for the Sunday shall serve all the week after, where it is not in this Book otherwise ordered.

¶ PROPER LESSONS					
TO BE READ AT MORNING AND EVENING PRAYER ON THE SUNDAYS, AND OTHER HOLIDAYS THROUGHOUT THE YEAR.					
¶ LESSONS PROPER FOR SUNDAYS.					
<i>Sundays of Advent.</i>	<i>Mattins.</i>	<i>Evensong.</i>	<i>Sundays after Easter.</i>	<i>Mattins.</i>	<i>Evensong.</i>
The first.	Isa. i.	Isa. ii.	v.	Deut. viii.	Deut. ix.
ii.	v.	xxiv.	<i>Sunday after Ascension-Day.</i>	xii.	xiii.
iii.	xxv.	xxvi.	<i>Whitsunday.</i>		
iv.	xxx.	xxxii.	1 Lesson.	xvi. to v. 18.	Isa. xi.
<i>Sundays after Christmas.</i>			2 Lesson.	Acts x. v. 34.	Acts xix. to v. 21.
The first.	xxxvii.	xxxviii.	<i>Trinity Sunday.</i>	Gen. i.	Gen. xviii.
ii.	xli.	xliii.	1 Lesson.	Matt. iii.	1 John v.
<i>Sundays after the Epiphany.</i>			2 Lesson.		
The first.	xliv.	xlvi.	<i>Sundays after Trinity.</i>		
ii.	li.	liii.	The first.	Josh. x.	Josh. xxiii.
iii.	lv.	lvi.	ii.	Judges iv.	Judges v.
iv.	lvii.	lviii.	iii.	1 Sam. ii.	1 Sam. iii.
v.	lix.	lxiv.	iv.	xii.	xiii.
vi.	lxv.	lxvi.	v.	xv.	xvii.
<i>Septuagesima.</i>	Gen. i.	Gen. ii.	vi.	2 Sam. xii.	2 Sam. xix.
<i>Sexagesima.</i>	iii.	vi.	vii.	xxi.	xxiv.
<i>Quinquagesima.</i>	ix. to v. 20.	xii.	viii.	1 Kings xiii.	1 Kings xvii.
<i>Lent.</i>			ix.	xviii.	xix.
First Sunday.	xix. to v. 30.	xxii.	x.	xxi.	xxii.
ii.	xxvii.	xxxiv.	xi.	2 Kings v.	2 Kings ix.
iii.	xxxix.	xlii.	xii.	x.	xviii.
iv.	xliii.	xlv.	xiii.	xix.	xxiii.
v.	Exod. iii.	Exod. v.	xiv.	Jere. v.	Jere. xxii.
vi.	ix.	x.	xv.	xxxv.	xxxvi.
1 Lesson.	Matt. xxvi.	Heb. v. to v. 11.	xvi.	Ezek. ii.	Ezek. xiii.
2 Lesson.			xvii.	xiv.	xviii.
<i>Easter Day.</i>	Exod. xii.	Exod. xiv.	xviii.	xx.	xxiv.
1 Lesson.	Rom. vi.	Acts ii. v. 22.	xix.	Dan. iii.	Dan. vi.
2 Lesson.			xx.	Joel ii.	Mic. vi.
<i>Sundays after Easter.</i>			xxi.	Hab. ii.	Prov. i.
The first.	Numb. xvi.	Numb. xxii.	xxii.	Prov. ii.	iii.
ii.	xxiii. xxiv.	xxv.	xxiii.	xi.	xii.
iii.	Deut. iv.	Deut. v.	xxiv.	xiii.	xiv.
iv.	vi.	vii.	xxv.	xv.	xvi.
			xxvi.	xvii.	xix.

Prayer Book¹. The system in use in the fifteenth century (and

we know scarcely any thing of what was in use before then) appears to have been the result of attempts to refine the use of Scripture in the Offices of the Church to a degree of pointedness which it never really attained, and which, perhaps, it was almost beyond human skill to give to it. And although such a pointedness is well adapted for educated and devotionally trained minds,

¹ It would appear from an old rubric that some discretion was left to the officiating clergyman with reference to the length of the Lesson, "Then let the same clerk who pronounces the Benediction, when enough at his discretion has been read," &c. Transl. of Sarum Psalter, p. 48.

LESSONS PROPER FOR HOLYDAYS.					
	<i>Mattins.</i>	<i>Evensong.</i>		<i>Mattins.</i>	<i>Evensong.</i>
<i>S. Andrew.</i>	Prov. xx.	Prov. xxi.	<i>Monday in Easter Week.</i>	Exod. xvi. Matt. xxviii.	Exod. xvii. Acts iii.
<i>S. Thomas the Apostle.</i>	xxiii.	xxiv.			
<i>Nativity of Christ.</i>	Isa. ix. to v. 8. Luke ii. to v. 15.	[to v. 17. Isa. vii. v. 10 Tit. iii. v. 4 to [v. 9.	<i>Tuesday in Easter Week.</i>	Exod. xx. Luke xxiv. to v.	Exod. xxxii. 1 Cor. xv.
<i>S. Stephen.</i>	Prov. xxviii. Acts vi. v. 8, and c. vii. to v. 30.	Eccles. iv. Acts vii. v. 30 to v. 55.	<i>S. Mark.</i>	Ecclus. iv. [13.	Ecclus. v.
<i>S. John.</i>	Eccles. v. Apoc. i. [v. 18. Jer. xxxi. to	Eccles. vi. Apoc. xxii. Wisd. i.	<i>S. Philip and S. Jacob.</i>	vii. John i. v. 43.	ix.
<i>Innocents' Day.</i>	Gen. xvii. Rom. ii.	Deut. x. v. 12. Colos. ii.	<i>Ascension Day.</i>	Deut. x. Luke xxiv. v. 44.	2 Kings ii. Eph. iv. to v. 17.
<i>Circumcision.</i>	Isa. lx. Luke iii. to v. 23.	Isa. xlix. John ii. to v. 12.	<i>Monday in Whitsun Week.</i>	Gen. xi. to v. 10. 1 Cor. xii.	[to v. 30. Num. xi. v. 16 1 Cor. xiv. to v. [26.
<i>Epiphany.</i>	Wisd. v. [22. Acts xxii. to v.	Wisd. vi. Acts xxvi.	<i>Tuesday in Whitsun Week.</i>	1 Sam. xix. v. 18. 1 Thess. v. v. [12 to v. 24.	Deut. xxx. * 1 John iv. to v. [14.
<i>Conversion of S. Paul.</i>	Wisd. ix. Ecclus. i.	Wisd. xii. Ecclus. i.	<i>S. Barnabas.</i>	Ecclus. x. Acts xiv.	Ecclus. xii. Acts xv. to v. 36.
<i>Purification of the Virgin Mary.</i>	Ecclus. ii.	iii.	<i>S. John Baptist.</i>	Malachi iii. Matt. iii.	Malachi iv. Matt. xiv. to v. [13.
<i>S. Matthias.</i>	Hosea xiii. John xi. v. 45.	Hosea xiv.	<i>S. Peter.</i>	Ecclus. xv. Acts iii. Ecclus. xxi.	Ecclus. xix. Acts iv. Ecclus. xxii.
<i>Annunciation of our Lady.</i>	Dan. ix. John xiii.	Jerem. xxxi.	<i>S. James.</i>	xxiv. xxxv.	xxix. xxxviii.
<i>Wednesday before Easter.</i>	Gen. xxii. to v. John xviii. [20.	Isa. liii. 1 Pet. ii.	<i>S. Bartholomew.</i>	Gen. xxxii. Acts xii. to v. 20. Ecclus. li.	Dan. x. v. 5. Jude v. 6 to v. 16. Job i.
<i>Thursday before Easter.</i>	Zech. ix. Luke xxiii. v. 50.	Exod. xiii. Heb. iv.	<i>S. Matthew.</i>	Job xxiv., xxv.	xlii.
<i>Good Friday.</i>			<i>S. Michael.</i>	Wisd. iii. to v. 10. Heb. xi. v. 33, & c. xii. to v. 7.	Wisd. v. to v. 17. Apoc. xix. to v. [17.
<i>Easter Even.</i>			<i>S. Luke.</i>		
			<i>S. Simon and S. Jude.</i>		
			<i>All Saints.</i>		

it would not produce the effect desired upon mixed congregations, and was better fitted for monastic than for popular use.

Some changes in the direction of our present Lectionary were made in the new and reformed editions of the Salisbury Portiforium, which were printed in 1516 and 1531: and more extensively by Cardinal Quignonez in his Reformed Roman Breviary of 1536. In this latter two lessons were appointed for ordinary days, one from the Old and another from the New Testament; and a third, generally from a Patristic Homily, for festivals. These were about the length of our Epistles and Gospels, or somewhat longer than most of them.

In the Prayer Book of 1549 our present system of daily and Proper Lessons was established, both being indicated in the Calendar, except in the case of the moveable festivals, when the chapter and verse for Mattins were referred to before the Introit (which preceded the Collect, Epistle, and Gospel of the day), and for Evensong after the Gospel. There were no Proper Lessons for ordinary Sundays, the books of Holy Scripture being read continuously on those as well as on week-days¹: nor were there so many proper lessons for festivals as there now are.

When Queen Elizabeth restored the use of the Prayer Book in

¹ It is observable that the Sunday Proper Lessons again break up that orderly system of reading the books of Holy Scripture through which is spoken of in the Preface. More than a hundred chapters of the Old Testament are thus displaced and omitted every year.

1559, the Tables of Proper Lessons were introduced, which were nearly identical with those now in the Prayer Book; and they were settled in their present form in 1661, all the changes being written in the margin of Bishop Cosin's Durham Prayer Book.

It is scarcely probable that any thing more was known of the primitive mode of reading Holy Scripture, by the Reformers of the sixteenth century, than is known by ourselves: yet in the Preface Archbishop Cranmer speaks of the manner in which the "ancient Fathers" ordered the whole Bible to be read over once every year. It has, however, been pointed out that there are some coincidences between our modern customs and those of primitive times, which seem as if they could hardly be accidental. "Thus, during Advent, the lessons for Sundays are selected from the book of Isaiah, and the same book was prescribed to be read during Advent by the Ordo Romanus. From Septuagesima to the Fifth Sunday in Lent, we read the book of Genesis on Sundays. St. John Chrysostom preached his homilies on this book at Antioch during Lent, and he remarks in several places that Genesis was appointed to be read at that season. After Pentecost the books of Samuel and Kings are read; and still later the books of Job, Proverbs, and Ecclesiastes, while Tobit and Judith are read nearer to Advent. The same order may be observed in the forms of the Church described by Rupertus Tuitensis (A. D. 1100), and in the Ordo Romanus. Coincidences may also be pointed out between the ancient lessons for par-

¶ PROPER PSALMS ON CERTAIN DAYS.					
	<i>Mattins.</i>	<i>Evensong.</i>		<i>Mattins.</i>	<i>Evensong.</i>
<i>Christmas Day.</i>	Psalm xix. xiv. lxxxv.	Psalm lxxxix. cx. cxxxii.	<i>Easter Day.</i>	Psalm ii. lvii. cxi.	Psalm cxiii. cxiv. cxviii.
<i>Ash-Wednesday.</i>	Psalm vi. xxxii. xxxviii.	Psalm cii. cxxx. cxliii.	<i>Ascension Day.</i>	Psalm viii. xv. xxi.	Psalm xxiv. xlvi. cviii.
<i>Good Friday.</i>	Psalm xxii. ¹ xl. liv.	Psalm lxix. lxxxviii.	<i>Whitsunday.</i>	Psalm xlvi. lxviii. ²	Psalm civ. cxlv.

¹ See Aug. in Joann. Hom. xiii.

² Salisb. Missal.

TABLES AND RULES FOR THE MOVEABLE AND IMMOVEABLE FEASTS, TOGETHER WITH THE DAYS OF FASTING AND ABSTINENCE THROUGH THE WHOLE YEAR.			
<p>⋄ RULES TO KNOW WHEN THE MOVEABLE FEASTS AND HOLYDAYS BEGIN.</p> <p><i>EASTER DAY</i>, on which the rest depend, is always the <i>First Sunday</i> after the Full Moon which happens upon, or next after the Twenty-first Day of <i>March</i>; and if the Full Moon happens upon a <i>Sunday</i>, <i>Easter Day</i> is the <i>Sunday</i> after.</p> <p><i>Advent Sunday</i> is always the nearest <i>Sunday</i> to the Feast of <i>S. Andrew</i>, whether before or after.</p>			
<p><i>Septuagesima</i> <i>Sextagesima</i> <i>Quinquagesima</i> <i>Quadragesima</i> <i>Rogation Sunday</i> <i>Ascension Day</i> <i>Whitsunday</i> <i>Trinity Sunday</i></p>	<p>Sunday is</p> <p style="font-size: 2em;">}</p> <p>is</p> <p style="font-size: 2em;">}</p>	<p>Nine Eight Seven Six Five Weeks Forty Days Seven Weeks Eight Weeks</p>	<p>Weeks before <i>Easter</i>.</p> <p>after <i>Easter</i>.</p>

ticular feasts mentioned in the latter formulary, and our own. Thus at the Nativity, Isaiah, chap. ix., is appointed in both; on the feast of St. Stephen, Acts, chap. vi.; on the feast of St. John, Apocalypse, chap. i.; at the Epiphany, Isaiah, chap. ix. (which was also the custom in the time of Maximus, Bishop of Turin, A.D. 450); on the feast of St. Peter, Acts, chap. iii.² [Palmer's Origines Liturgicæ, i. 254.]

The cycle of the Sunday Proper Lessons appears to have been formed in illustration of God's dealings with the Church of the Old Testament, though this idea is sometimes subordinated to the season, as in the Lessons for some of the Sundays in Lent. That for the other Holydays (with a few exceptions) is made up out of the didactic books of the Old Testament and the Apocrypha, and is not connected in any way with the Sunday cycle. The accidental combination of the fixed cycle of Proper Lessons with the variable one of the Second Lessons sometimes throws a wonderful flood of light upon both the Old and New Testament Scriptures: and it may be doubted whether any equal advantage would be gained by the substitution of Proper Lessons from the latter for the present system of reading it in order.

TABLE OF PROPER PSALMS.

The only days for which Proper Psalms were appointed previously to 1661, were Christmas Day, Easter Day, Ascension

Day, and Whitsun Day. Those for Ash-Wednesday and Good Friday were then added; and they appear, with the following other important additions to the Table, in the margin of the Durham Prayer Book of Bishop Cosin.

§ Additional Proper Psalms proposed by Bishop Cosin.

	MATTINS.	EVENSONG.
Epiphany	Psalm 2. 67.	Psalm 72. 97.
Rogation Monday ¹	— 12, 13, 107.	— 86, 90.
Rogation Tuesday	— 28, 42.	— 46, 70.
Rogation Wednesday	— 8, 19, 33.	— 103, 104, 144.
St. Michael and All Angels...	— 34, 80, 91.	— 163, 104, 143.
All Saints' Day	— 1, 15, 84, 91.	— 112, 113, 119, 1st part, 145, 149.

THE TABLES AND RULES.

These were nearly all of them new insertions at the last revisor of the Prayer Book in 1661, and a large portion of them were

¹ In Bp. Cosin's MS. note the Rogation Psalms are all included under Mattins. From a difference in the appearance of the figures which are here placed under Evensong, it is evident they were written in afterwards, and in the wrong column, by mistake. The others are all written as they are printed above.

A TABLE OF ALL THE FEASTS		
THAT ARE TO BE OBSERVED IN THE		
CHURCH OF ENGLAND THROUGHOUT THE YEAR.		
All Sundays in the Year.		
The Days of the Feasts of	The Circumcision of our Lord JESUS CHRIST.	
	The Epiphany.	
	The Conversion of <i>S. Paul.</i>	
	The Purification of the Blessed Virgin.	
	<i>S. Matthias</i> the Apostle.	
	The Annunciation of the Blessed Virgin.	
	<i>S. Mark</i> the Evangelist.	
	<i>S. Philip</i> and <i>S. James</i> the Apostles.	
	The Ascension of our Lord JESUS CHRIST.	
	<i>S. Barnabas.</i>	
	The Nativity of <i>S. John</i> Baptist.	
	<i>Monday and Tuesday in Easter Week.</i> <i>Monday and Tuesday in Whitsun Week.</i>	
	The Days of the Feasts of	<i>S. Peter</i> the Apostle.
<i>S. James</i> the Apostle.		
<i>S. Bartholomew</i> the Apostle.		
<i>S. Matthew</i> the Apostle.		
<i>S. Michael</i> and all Angels.		
<i>S. Luke</i> the Evangelist.		
<i>S. Simon</i> and <i>S. Jude</i> , Apos- tles.		
All Saints.		
<i>S. Andrew</i> the Apostle.		
<i>S. Thomas</i> the Apostle.		
The Nativity of our Lord.		
<i>S. Stephen</i> the Martyr.		
<i>S. John</i> the Evangelist.		
The Holy Innocents.		

taken out of Bishop Cosin's Collection of Private Devotions. Previous editions of the Prayer Book contained "an Almanack for thirty-nine years," which was the same as our "Table of Moveable Feasts;" a "Table to find Easter for ever;" the list of days beginning "Septuagesima," but without Ascension Day, and without any prefix whatever; and a short list of Holydays. The general title, "Tables and Rules, &c.," is in the Durham Book in Bishop Cosin's handwriting: and all the ecclesiastical alterations and insertions appear to have been made by him. The chronological apparatus of the Calendar was, however, revised by Dr. John Pell (a very learned man, and a friend of Vossius¹), in conjunction with Sancroft as secretary to the Committee of Revision. Of this chronological apparatus there is no trace whatever in Bishop Cosin's Prayer Book. In 1752 (24 Geo. II.) "an Act for regulating the commencement of the year, and for correcting the Calendar," was passed, and from this the present tables of the Prayer Book are printed, not from the Sealed Books.

§ *Rules to know when the Moveable Feasts and Holydays begin.*

These rules stand exactly as they do in Cosin's Devotions, as published in 1627: except that the day of the month is substituted for the words "Equinoctial of the Spring in March." The rule for finding Easter (founded on a decree of the Council of Nicæa) is not quite exactly stated. Instead of "Full Moon" it ought to say, "the 14th day of the Calendar Moon, whether that day be the actual Full Moon or not." In some years (as in 1818 and 1845) the Full Moon and Easter coincide, and this rule then contradicts the Tables.

¹ It was the strange fate of this learned man to be so poor that he could not get even pens, ink, and paper, and the necessaries of life: and he was buried by the charity of Dr. Busby in the Rector's vault at St. Giles's in the Fields.

There is a curious old rough and ready rule for finding Easter contained in a rhyme found in some old Sarum Missals:—

"In Marche after the first C [C or new moon]
The next prime tell to me.
The thridde sunday ful I wis
Paske dai sikir [surely] hit is."

This seems as correct as it is easy to use, e. g. :—

	New Moon in March.	1st Sunday.	2nd Sunday.	Easter Day.
1786	Monday, 27.	April 2.	April 9.	April 16.
1860	Thursday, 23.	March 25.	April 1.	April 8.
1861	Monday, 11.	March 17.	March 24.	March 31.
1862	Sunday, 30.	April 6.	April 13.	April 20.
1865	Monday, 27.	April 2.	April 9.	April 16.

Advent Sunday] To this rule should be added, "or on that feast itself," as Advent Sunday occurs on November 30th about once in every seven years on the average.

§ *The Table of Feasts.*

This Table is not in Cosin's Devotions, though the days are all marked in the Calendar of the volume; but it is in MS. in the margin of his Durham Prayer Book. The remarks made by him in the Notes on the Prayer Book published in the fifth volume of his works show that he had long wished to see a more complete list of the Holydays of the Church printed in the Calendar; and that he thought the abbreviated list of former Prayer Books was the fault of the printer.

All the Feasts in this table have their own Collects, Epistles and Gospels, and notices of the days will be found in the foot notes appended to these in their proper places.

A TABLE OF THE VIGILS, FASTS, AND DAYS OF ABSTINENCE, TO BE OBSERVED IN THE YEAR.			
The Evens or Vigils before	<p>The Nativity of our Lord. The Purification of the Blessed Virgin <i>Mary</i>. The Annunciation of the Blessed Virgin. Easter Day. Ascension Day. Pentecost. <i>S. Matthias</i>.</p>	The Evens or Vigils before	<p><i>S. John Baptist</i>. <i>S. Peter</i>. <i>S. James</i>. <i>S. Bartholomew</i>. <i>S. Matthew</i>. <i>S. Simon and S. Jude</i>. <i>S. Andrew</i>. <i>S. Thomas</i>. All Saints.</p>
<p>Note, that if any of these Feast Days fall upon a <i>Monday</i>, then the Vigil or Fast Day shall be kept upon the <i>Saturday</i>, and not upon the <i>Sunday</i> next before it.</p>			
DAYS OF FASTING, OR ABSTINENCE.			
<p>I. The Forty Days of Lent. II. The Ember Days at the Four Seasons, being the <i>Wednesday</i>, <i>Friday</i>, and <i>Saturday</i> after . . .</p>		<p>The First <i>Sunday</i> in Lent. The Feast of <i>Pentecost</i>. <i>September 14</i>. <i>December 13</i>.</p>	
<p>III. The Three <i>Rogation Days</i>, being the <i>Monday</i>, <i>Tuesday</i>, and <i>Wednesday</i> before <i>Holy Thursday</i>, or the <i>Ascension</i> of our LORD. IV. All the <i>Fridays</i> in the Year, except <i>Christmas Day</i>.</p>			
A SOLEMN DAY, FOR WHICH A PARTICULAR SERVICE IS APPOINTED.			
<p>The Twentieth Day of <i>June</i>, being the Day on which her Majesty began her happy Reign.</p>			

§ *The Table of Vigils, Fasts, and Days of Abstinence.*

This, together with the "certain Solemn Days" (now reduced to one), originally appeared in Cosin's Devotions, and is also written in the margin of the Durham Prayer Book. At the end of the MS. note is written an addition taken from the Devotions, but not eventually printed in the Prayer Book:

"By the ecclesiastical laws of this Realm, there be some times in the year wherein Marriages are not usually solemnized¹; viz.

from	<table style="border: none;"> <tr> <td style="border: none;">{ Advent</td> <td style="border: none;">{ Sunday</td> <td style="border: none;">{ eight days after the Epiphany.</td> </tr> <tr> <td style="border: none;">{ Septuagesima</td> <td style="border: none;">{ until</td> <td style="border: none;">{ eight days after Easter.</td> </tr> <tr> <td style="border: none;">{ Rogation</td> <td style="border: none;"></td> <td style="border: none;">{ Trinity Sunday."</td> </tr> </table>	{ Advent	{ Sunday	{ eight days after the Epiphany.	{ Septuagesima	{ until	{ eight days after Easter.	{ Rogation		{ Trinity Sunday."	
{ Advent	{ Sunday	{ eight days after the Epiphany.									
{ Septuagesima	{ until	{ eight days after Easter.									
{ Rogation		{ Trinity Sunday."									

Cosin also wrote, "All the Fridays in the year except the twelve days of Christmas."

Some notes on the subject of Fasting will be found under the head of Lent [p. 90]; the Ember Days are noticed in connexion with Ordination Services, and the Rogation Days in the Notes to the Fifth Sunday after Easter [p. 110].

All Festivals have Evens, including Sundays, but only some

¹ See notes on the Marriage Service, p. 263.

have Vigils. The festivals that fall during the seasons of Christmas, Easter, and Whitsuntide have no vigils, Fridays being the only days of Abstinence in those joyous periods. St. Luke's day is without a Vigil, either because the Evangelist is thought to have died in peace without martyrdom, or because the minor festival of St. Etheldreda occupies the 17th of October. Michaelmas Day is without a Vigil, because the Holy Angels had no day of trial like the Saints before entering into Heaven: and of this the Vigil is a symbolical observance. The use of the words Vigil and Even at the time when the Prayer Book was first translated is illustrated by the following passage from Cranmer's answer to the Devonshire rebels:—"For as *Vigils*, otherwise called Watchings, remained in the calendars upon certain *saints' evens* because in old times the people watched all those nights . . . but now these many years those vigils remained in vain in the books, for no man did watch." [Strype's Cranmer, ii. 533.]

The Vigil was originally that which its name indicates, a night spent in watching and prayer. The scandals which arose out of these nocturnal Services, however, made it necessary to abolish them [Durand. vi. 7]; and a fast on the day before was sub-

A TABLE TO FIND EASTER DAY, FROM THE PRESENT TIME TILL THE YEAR 1899 INCLUSIVE, ACCORDING TO THE FOREGOING CALENDAR.		
Golden Number.	Day of the Month.	Sunday Letter.
XIV	March 21	C
III	— 22	D
	— 23	E
XI	— 24	F
	— 25	G
XIX	— 26	A
VIII	— 27	B
	— 28	C
XVI	— 29	D
V	— 30	E
	— 31	F
XIII	April 1	G
II	— 2	A
	— 3	B
X	— 4	C
	— 5	D
XVIII	— 6	E
VII	— 7	F
	— 8	G
XV	— 9	A
IV	— 10	B
	— 11	C
XII	— 12	D
I	— 13	E
	— 14	F
IX	— 15	G
	— 16	A
XVII	— 17	B
VI	— 18	C
	— 19	D
	— 20	E
	— 21	F
	— 22	G
	— 23	A
	— 24	B
	— 25	C

THIS Table contains so much of the Calendar as is necessary for the determining of *Easter*; To find which, look for the Golden Number of the year in the first Column of the Table, against which stands the Day of the Paschal Full Moon; then look in the third column for the Sunday Letter, next after the day of the Full Moon, and the day of the Month standing against that Sunday Letter is *Easter Day*. If the Full Moon happens upon a Sunday, then (according to the first rule) the next Sunday after is *Easter Day*.

To find the Golden Number, or Prime, add one to the Year of our Lord, and then divide by 19; the remainder, if any, is the Golden Number; but if nothing remaineth, then 19 is the Golden Number.

To find the Dominical or Sunday Letter, according to the Calendar, until the year 1799 inclusive, add to the Year of our Lord its fourth part, omitting fractions; and also the number 1: Divide the sum by 7; and if there is no remainder, then A is the Sunday Letter: But if any number remaineth, then the Letter standing against that number in the small annexed Table is the Sunday Letter.

0	A
1	G
2	F
3	E
4	D
5	C
6	B

For the next Century, that is, from the year 1800 till the year 1899 inclusive, add to the current year only its fourth part, and then divide by 7, and proceed as in the last Rule.

NOTE, That in all Bissextile or Leap Years, the Letter found as above will be the Sunday Letter, from the intercalated day exclusive to the end of the year.

stituted which still retains the name of Vigil. The Vigil is not therefore connected with the Evening Service, but is the day before the Festival to which it belongs, and since (according to the accustomed habit of the Church) the Festival itself begins on the evening previous, the Vigil ends before that Evening service (if there is more than one) which is observed as the first Vespers of the feast. That, in mediæval times, the whole of the day before the Festival was observed as the Vigil may be seen by the following Rubric for the first Sunday in Advent: "Non dicatur etiam per totum annum Te Deum laudamus in Vigiliis, nec in quatuor temporibus, nisi in Vigilia Epiphaniæ quando in Dominica contigerit, et præterquam in quatuor temporibus hebdomadæ Pentecostes." The Te Deum was used at Mattins: the use of it here referred to must therefore be at the Mattins of the Vigil. Some remarks on the observance of Vigils may be found in Tracts for the Times, No. 66, pp. 11, 12.

The accession of the Sovereign was first observed as a "Solemn Day" in the reign of Queen Elizabeth; but no mention of such a day was made in the Prayer Book until late in the last century. The above notice of the day has not therefore the authority of the Sealed Books, nor of the Act of 1752, but is printed in

reference to Royal Proclamations dated June 21st, 1837, and Jan. 17th, 1859.

§ *The Table to find Easter till 1899.*

This Table is an extract from the first three columns of the Calendar during the Paschal limits, or the period during which Easter Day must always fall. It was substituted in 1752 (with the succeeding one) for "a Table to find Easter for ever" which had been printed in previous Prayer Books, but which had been framed on a mistaken supposition respecting the perpetual application of the cycle of Golden Numbers to fixed days of the months. A change in the application of the cycle will be necessary in the year 1900, (provided for by another Table further on,) when the above will be superseded for all future calculations.

The Golden Numbers and the Sunday Letters are explained in the notes to the General Tables for finding them.

These Tables are a solution of a difficulty about the determination of Easter Day, which caused considerable trouble to the Church when astronomy, and consequently Chronology, was imperfectly understood. The Nicene Council (A.D. 325) endeav-

A TABLE TO FIND EASTER.

ANOTHER TABLE TO FIND EASTER TILL THE YEAR 1899 INCLUSIVE.							
SUNDAY LETTERS.							
GOLDEN NUMBER.	A	B	C	D	E	F	G
I	April 16	— 17	— 18	— 19	— 20	— 14	— 15
II	April 9	— 3	— 4	— 5	— 6	— 7	— 8
III	March 26	— 27	— 28	— 29	— 23	— 24	— 25
IV	April 16	— 17	— 11	— 12	— 13	— 14	— 15
V	April 2	— 3	— 4	— 5	— 6	March 31	April 1
VI	April 23	— 24	— 25	— 19	— 20	— 21	— 22
VII	April 9	— 10	— 11	— 12	— 13	— 14	— 8
VIII	April 2	— 3	March 28	— 29	— 30	— 31	April 1
IX	April 16	— 17	— 18	— 19	— 20	— 21	— 22
X	April 9	— 10	— 11	— 5	— 6	— 7	— 8
XI	March 26	— 27	— 28	— 29	— 30	— 31	— 25
XII	April 16	— 17	— 18	— 19	— 13	— 14	— 15
XIII	April 2	— 3	— 4	— 5	— 6	— 7	— 8
XIV	March 26	— 27	— 28	— 22	— 23	— 24	— 25
XV	April 16	— 10	— 11	— 12	— 13	— 14	— 15
XVI	April 2	— 3	* — 4	— 5	March 30	— 31	April 1
XVII	April 23	— 24	— 18	— 19	— 20	— 21	— 22
XVIII	April 9	— 10	— 11	— 12	— 13	— 7	— 8
XIX	April 2	March 27	— 28	— 29	— 30	— 31	April 1

To make use of the preceding Table, find the Sunday Letter for the Year in the uppermost Line, and the Golden Number, or Prime, in the Column of Golden Numbers, and against the Prime, in the same Line under the Sunday Letter, you have the Day of the Month on which EASTER falleth that year. But Note, that the Name of the Month is set on the Left Hand, or just with the Figure, and followeth not, as in other Tables, by Descent, but Collateral.

voured to settle this difficulty and the Quartodeciman controversy [see notes on Easter Day] by the following epistolary decrees:—

1. That the twenty-first day of March is to be taken as the vernal equinox.
2. That the full moon happening upon or next after the twenty-first day of March is to be taken for the full moon of the month Nisan.
3. That the next Lord's Day after that full moon is to be observed as Easter Day.
4. Unless the full moon happens upon a Sunday, when Easter Day is to be the next Sunday.

But to observe these rules it was necessary to ascertain the age of the moon: and although this could be done correctly for a period by means of a cycle of the moon discovered by Meton, an Athenian philosopher, which set forth the change of the moon for nineteen years, and which was supposed to repeat itself *ad infinitum*, yet a more accurate knowledge of astronomy showed that

this rule was subject to error, and that Easter Day was sometimes too early and sometimes too late to commemorate our Lord's Resurrection with the accuracy which was intended by the Nicene Council. This erroneous system was not corrected, however, until the introduction of the "New Style" by Pope Gregory XIII. in 1582; and the New Style was not introduced into England until 1752, when the Act of Parliament was passed from which the present Calendar is printed.

These Tables for finding Easter, together with those which follow, are part of the Act of Parliament referred to [24 Geo. II. c. 23], and have not received the same authority as the Prayer Book itself. Nor does there seem to be any practical necessity for binding them up with every edition of the Prayer Book as is the present custom, since they are of far too recondite a character to be of any use except to highly scientific students; and for ordinary use the Table of Moveable Feasts is amply sufficient.

A TABLE OF THE MOVEABLE FEASTS
FOR THE REST OF THE NINETEENTH CENTURY,
ACCORDING TO THE FOREGOING CALENDAR.

Year of our Lord.	The Golden Number.	The Epact.	Sunday Letter.	Sundays after Epiphany.	Septuagesima Sunday.	The First Day of Lent.	Easter Day.	Rogation Sunday.	Ascension Day.	Whitsun Day.	Sundays after Trinity.	Advent Sunday.
1866	V	14	G	Three	Jan. 28	Feb. 14	Apr. 1	May 6	May 10	May 20	Twenty-six	Dec. 2
1867	VI	25	F	Five	Feb. 17	Mar. 6	— 21	— 26	— 30	June 9	Twenty-three	— 1
1868	VII	6	ED	Four	— 9	Feb. 26	— 12	— 17	— 21	May 31	Twenty-four	Nov. 29
1869	VIII	17	C	Two	Jan. 24	— 10	Mar. 28	— 2	— 6	— 16	Twenty-six	— 28
1870	IX	28	B	Five	Feb. 13	Mar. 2	Apr. 17	— 22	— 26	June 5	Twenty-three	— 27
1871	X	9	A	Four	— 5	Feb. 22	— 9	— 14	— 18	May 28	Twenty-five	Dec. 3
1872	XI	20	GF	Three	Jan. 28	— 14	Mar. 31	— 5	— 9	— 19	Twenty-six	— 1
1873	XII	1	E	Four	Feb. 9	— 26	Apr. 13	— 18	— 22	June 1	Twenty-four	Nov. 30
1874	XIII	12	D	Three	— 1	— 18	— 5	— 10	— 14	May 24	Twenty-five	— 29
1875	XIV	23	C	Two	Jan. 24	— 10	Mar. 28	— 2	— 6	— 16	Twenty-six	— 28
1876	XV	4	BA	Five	Feb. 13	Mar. 1	Apr. 16	— 21	— 25	June 4	Twenty-four	Dec. 3
1877	XVI	15	G	Three	Jan. 28	Feb. 14	— 1	— 6	— 10	May 20	Twenty-five	— 2
1878	XVII	26	F	Five	Feb. 17	Mar. 6	— 21	— 26	— 30	June 9	Twenty-three	— 1
1879	XVIII	7	E	Four	— 9	Feb. 26	— 13	— 18	— 22	— 1	Twenty-four	Nov. 30
1880	XIX	18	DC	Two	Jan. 25	— 11	Mar. 28	— 2	— 6	May 16	Twenty-six	— 28
1881	I	0	B	Five	Feb. 13	Mar. 2	Apr. 17	— 22	— 26	June 5	Twenty-three	— 27
1882	II	11	A	Four	— 5	Feb. 22	— 9	— 14	— 18	May 28	Twenty-five	Dec. 3
1883	III	22	G	Two	Jan. 21	— 7	Mar. 25	Apr. 29	— 3	— 13	Twenty-seven	— 2
1884	IV	3	FE	Four	Feb. 10	— 27	Apr. 13	May 18	— 22	June 1	Twenty-four	Nov. 30
1885	V	14	D	Three	— 1	— 18	— 5	— 10	— 14	May 24	Twenty-five	— 29
1886	VI	25	C	Six	— 21	Mar. 10	— 25	— 30	June 3	June 13	Twenty-two	— 28
1887	VII	6	B	Four	— 6	Feb. 23	— 10	— 15	May 19	May 29	Twenty-four	— 27
1888	VIII	17	AG	Three	Jan. 29	— 15	— 1	— 6	— 10	— 20	Twenty-six	Dec. 2
1889	IX	28	F	Five	Feb. 17	Mar. 6	— 21	— 26	— 30	June 9	Twenty-three	— 1
1890	X	9	E	Three	— 2	Feb. 19	— 6	— 11	— 15	May 25	Twenty-five	Nov. 30
1891	XI	20	D	Two	Jan. 25	— 11	Mar. 29	— 3	— 7	— 17	Twenty-six	— 29
1892	XII	1	CB	Five	Feb. 14	Mar. 2	Apr. 17	— 22	— 26	June 5	Twenty-three	— 27
1893	XIII	12	A	Three	Jan. 29	Feb. 15	— 2	— 7	— 11	May 21	Twenty-six	Dec. 3
1894	XIV	23	G	Two	— 21	— 7	Mar. 25	Apr. 29	— 3	— 13	Twenty-seven	— 2
1895	XV	4	F	Four	Feb. 10	— 27	Apr. 14	May 19	— 23	June 2	Twenty-four	— 1
1896	XVI	15	ED	Three	— 2	— 19	— 5	— 10	— 14	May 24	Twenty-five	Nov. 29
1897	XVII	26	C	Five	— 14	Mar. 3	— 18	— 23	— 27	June 6	Twenty-three	— 28
1898	XVIII	7	B	Four	— 6	Feb. 23	— 10	— 15	— 19	May 29	Twenty-four	— 27
1899	XIX	18	A	Three	Jan. 29	— 15	— 2	— 7	— 11	— 21	Twenty-six	Dec. 3
1900	I	0	G	Five	Feb. 11	— 28	— 15	— 20	— 24	June 3	Twenty-four	— 2

[N.B. This Table is only a representative and not a facsimile of the Table in the Act of Parliament. The latter extends from 1752 to 1804.]

THE EPACT.

The difference between the length of the solar year and that of the lunar year is eleven days; the solar year being made up of 365 days, and the lunar year of twelve months or moons, of twenty-nine and a half days each, or 354 days in all. The last day of the lunar year being the last day of the twelfth moon, and the last day of the solar year being the 31st of December, the difference between these constitutes the Epact¹. In the first year

of the present cycle the lunar year and the solar year both commenced on the 1st of January; the Epact for the second year was therefore 11, for the third 22, for the fourth 33, and so forth in a regular succession. The *whole* months are not reckoned, however, and instead of 33, the Epact is taken as 3, instead of 36 as 6, and so forth.

A cycle of nineteen Epacts is thus formed which always runs parallel to the nineteen Golden Numbers in the following order:

Golden Numbers	1	2	3	4	5	6	7	8	9	10	11	12	13	14	15	16	17	18	19
Epacts	0	11	22	3	14	25	6	17	28	9	20	1	12	23	4	15	26	7	18

The Epact is used for calculating the age of the Moon on any day in any year. To do this, (1) Add together the day of the month and the Epact: (2) If the month is one later on in the year than March, add also the number of months including March and the one for which the calculation is required. The result will give the moon's age within a fraction of a day. Thus:—

1865. October 10th.
 3 The Epact.
 —
 13
 8 months from March to October, inclusive.
 —
 days 21 = Approximate age of the Moon.

¹ Ἐπακταὶ ἡμέραι. Intercalary days.

The true age of the moon on Oct. 10, 1865, at noon, being 20 days and 14 hours.

The use of the Epacts (in connexion with the Sunday letters), for finding out Easter Day, may be thus illustrated for the year 1887. Find out the moon's age for some day on which Easter can fall, say April 1st.

1887. April 1
 6 Epact.
 2 March and April inclusive.
 —
 days 9 = age of the moon on April 1.

The Paschal Full Moon is the 14th day of the Moon's age, and this will be April 6th. (2) Easter Day being the Sunday after the Paschal Full Moon, and B being the Sunday letter for 1887, the first B after April 6th will show that April 10th is Easter Day in that year.

A TABLE OF THE MOVEABLE FEASTS.

A TABLE OF THE MOVEABLE FEASTS, ACCORDING TO THE SEVERAL DAYS THAT EASTER CAN POSSIBLY FALL UPON.								
Easter Day.	Sundays after Epiphany.	Septuagesima Sunday.	The First Day of Lent.	Rogation Sunday.	Ascension Day.	Whitsun Day.	Sundays after Trinity.	Advent Sunday.
Mar. 22	One	Jan. 18	Feb. 4	Apr. 26	Apr. 30	May 10	Twenty-seven	Nov. 29
— 23	One	— 19	— 5	— 27	May 1	— 11	Twenty-seven	— 30
— 24	One	— 20	— 6	— 28	May 2	— 12	Twenty-seven	Dec. 1
— 25	Two	— 21	— 7	— 29	— 3	— 13	Twenty-seven	— 2
— 26	Two	— 22	— 8	— 30	— 4	— 14	Twenty-seven	— 3
— 27	Two	— 23	— 9	May 1	— 5	— 15	Twenty-six	Nov. 27
— 28	Two	— 24	— 10	— 2	— 6	— 16	Twenty-six	— 28
— 29	Two	— 25	— 11	— 3	— 7	— 17	Twenty-six	— 29
— 30	Two	— 26	— 12	— 4	— 8	— 18	Twenty-six	— 30
— 31	Two	— 27	— 13	— 5	— 9	— 19	Twenty-six	Dec. 1
Apr. 1	Three	— 28	— 14	— 6	— 10	— 20	Twenty-six	— 2
— 2	Three	— 29	— 15	— 7	— 11	— 21	Twenty-six	— 3
— 3	Three	— 30	— 16	— 8	— 12	— 22	Twenty-five	Nov. 27
— 4	Three	— 31	— 17	— 9	— 13	— 23	Twenty-five	— 28
— 5	Three	Feb. 1	— 18	— 10	— 14	— 24	Twenty-five	— 29
— 6	Three	— 2	— 19	— 11	— 15	— 25	Twenty-five	— 30
— 7	Three	— 3	— 20	— 12	— 16	— 26	Twenty-five	Dec. 1
— 8	Four	— 4	— 21	— 13	— 17	— 27	Twenty-five	— 2
— 9	Four	— 5	— 22	— 14	— 18	— 28	Twenty-five	— 3
— 10	Four	— 6	— 23	— 15	— 19	— 29	Twenty-four	Nov. 27
— 11	Four	— 7	— 24	— 16	— 20	— 30	Twenty-four	— 28
— 12	Four	— 8	— 25	— 17	— 21	— 31	Twenty-four	— 29
— 13	Four	— 9	— 26	— 18	— 22	June 1	Twenty-four	— 30
— 14	Four	— 10	— 27	— 19	— 23	— 2	Twenty-four	Dec. 1
— 15	Five	— 11	— 28	— 20	— 24	— 3	Twenty-four	— 2
— 16	Five	— 12	Mar. 1	— 21	— 25	— 4	Twenty-four	— 3
— 17	Five	— 13	— 2	— 22	— 26	— 5	Twenty-three	Nov. 27
— 18	Five	— 14	— 3	— 23	— 27	— 6	Twenty-three	— 28
— 19	Five	— 15	— 4	— 24	— 28	— 7	Twenty-three	— 29
— 20	Five	— 16	— 5	— 25	— 29	— 8	Twenty-three	— 30
— 21	Five	— 17	— 6	— 26	— 30	— 9	Twenty-three	Dec. 1
— 22	Six	— 18	— 7	— 27	— 31	— 10	Twenty-three	— 2
— 23	Six	— 19	— 8	— 28	June 1	— 11	Twenty-three	— 3
— 24	Six	— 20	— 9	— 29	— 2	— 12	Twenty-two	Nov. 27
— 25	Six	— 21	— 10	— 30	— 3	— 13	Twenty-two	— 28

NOTE, that in a Bissextile or Leap Year, the Number of Sundays after Epiphany will be the same, as if Easter Day had fallen One Day later than it really does. And for the same reason, One Day must, in every Leap Year, be added to the Day of the Month given by the Table for Septuagesima Sunday: And the like must be done for the First Day of Lent (commonly called Ash-Wednesday), unless the Table gives some Day in the Month of March for it; for in that case the Day given by the Table is the right Day.

The order in which this Table follows the others makes its use sufficiently evident. The two first Tables being given for the purpose of finding the date of the Festival by which all the moveable Holydays are regulated, and a third added which sets forth all the moveable Holydays for many years to come, this

Table is given as a means of finding out for any year, past or future, the respective dates of these days, according to that of Easter. The Note respecting Leap Year must not be overlooked when this Table is used.

TABLE TO FIND EASTER DAY		
FROM		
THE YEAR 1900 TO THE YEAR 2199 INCLUSIVE.		
Golden Number.	Day of the Month.	Sunday Letters.
XIV	March 22	D
III	— 23	E
	— 24	F
XI	— 25	G
	— 26	A
XIX	— 27	B
VIII	— 28	C
	— 29	D
XVI	— 30	E
V	— 31	F
	April 1	G
XIII	— 2	A
II	— 3	B
	— 4	C
X	— 5	D
	— 6	E
XVIII	— 7	F
VII	— 8	G
	— 9	A
XV	— 10	B
IV	— 11	C
	— 12	D
XII	— 13	E
I	— 14	F
	— 15	G
IX	— 16	A
XVII	— 17	B
VI	— 18	C
	— 19	D
	— 20	E
	— 21	F
	— 22	G
	— 23	A
	— 24	B
	— 25	C

The Golden Numbers in the foregoing Calendar will point out the Days of the Paschal Full Moons, till the Year of our Lord 1900; at which Time, in order that the Ecclesiastical Full Moons may fall nearly on the same Days with the real Full Moons, the Golden Numbers must be removed to different Days of the Calendar, as is done in the annexed Table, which contains so much of the Calendar then to be used, as is necessary for finding the Paschal Full Moons, and the Feast of *Easter*, from the Year 1900, to the Year 2199 inclusive. This Table is to be made use of, in all respects, as the first Table before inserted, for finding *Easter* till the Year 1899.

This Table is simply for revising the first and third columns of that portion of the Calendar which extends over the Paschal limits, i. e. those days in March and April that Easter can possibly fall on. It will not come into use before the year 1900, and is then applicable for three hundred years.

GENERAL TABLES												
FOR FINDING THE DOMINICAL OR SUNDAY LETTER, AND THE PLACES OF THE GOLDEN NUMBERS IN THE CALENDAR.												
TABLE I.							TABLE II.					
6	5	4	3	2	1	0	I.	II.	III.	I.	II.	III.
B	C	D	E	F	G	A	Years of our Lord.			Years of our Lord.		
				1600	1700	1800	B	1600	0	B	5200	15
								1700	1		5300	16
								1800	1		5400	17
								1900	2		5500	17
1900			2300	2500	2600	2700	B	2000	2	B	5600	17
2000	2100	2200	2400		2800			2100	2		5700	18
					3500			2200	3		5800	18
2900	3000	3100	3300	3400	3600	3700		2300	4		5900	19
3800	3900			4800	4500	4600	B	2400	3	B	6000	19
	4000	4100	4200	4400				2500	4		6100	19
								2600	5		6200	20
4700			5100	5300	5400	5500		2700	5		6300	21
4800	4900	5000	5200				B	2800	5	B	6400	20
		5900		6300	6400	6500		2900	6		6500	21
5700	5800	6000	6100	6200				3000	6		6600	22
								3100	7		6700	23
6600	6700			7100	7300	7400	B	3200	7	B	6800	22
	6800	6900	7000	7200				3300	7		6900	23
								3400	8		7000	24
7500			7900	8100	8200	8300		3500	9		7100	24
7600	7700	7800	8000			8400	B	3600	8	B	7200	24
								3700	9		7300	25
8500	&c.							3800	10		7400	25
								3900	10		7500	26
							B	4000	10	B	7600	26
								4100	11		7700	26
								4200	12		7800	27
								4300	12		7900	28
							B	4400	12	B	8000	27
								4500	13		8100	28
								4600	13		8200	29
								4700	14		8300	29
							B	4800	14	B	8400	29
								4900	14		8500	0
								5000	15		&c.	
								5100	16			

To find the Dominical or Sunday Letter for any given Year of our Lord, add to the year its fourth part, omitting fractions, and also the number, which in Table I. standeth at the top of the column, wherein the number of hundreds contained in that given year is found: Divide the sum by 7, and if there is no remainder, then A is the Sunday Letter; but if any number remaineth, then the Letter, which standeth under that number at the top of the Table, is the Sunday Letter.

To find the Month and Days of the Month to which the Golden Numbers ought to be prefixed in the Calendar, in any given Year of our Lord consisting of entire hundred years, and in all the intermediate years betwixt that and the next hundredth year following, look in the second column of Table II. for the given year consisting of entire hundreds, and note the number or cypher which stands against it in the third column; then, in Table III. look for the same number in the column under any given Golden Number, which when you have found, guide your eye side-ways to the left hand, and in the first column you will find the Month and Day to which that Golden Number ought to be prefixed in the Calendar, during that period of one hundred years.

The letter B prefixed to certain hundredth years in Table II. denotes those years which are still to be accounted Bissextile or Leap Years in the New Calendar; whereas all the other hundredth years are to be accounted only common years.

§ The Dominical or Sunday Letters.

The second column of the Calendar is occupied by the first

seven letters of the alphabet, which are repeated throughout the year, beginning with A on the first of January. If the first of January is on a Sunday, A is the Sunday Letter for that year;

TABLE III.

Paschal Full Moon.	Sunday Letter.	THE GOLDEN NUMBERS.																		
		1	2	3	4	5	6	7	8	9	10	11	12	13	14	15	16	17	18	19
March 21	C	8	19	0	11	22	3	14	25	6	17	28	9	20	1	12	23	4	15	26
March 22	D	9	20	1	12	23	4	15	26	7	18	29	10	21	2	13	24	5	16	27
March 23	E	10	21	2	13	24	5	16	27	8	19	0	11	22	3	14	25	6	17	28
March 24	F	11	22	3	14	25	6	17	28	9	20	1	12	23	4	15	26	7	18	29
March 25	G	12	23	4	15	26	7	18	29	10	21	2	13	24	5	16	27	8	19	0
March 26	A	13	24	5	16	27	8	19	0	11	22	3	14	25	6	17	28	9	20	1
March 27	B	14	25	6	17	28	9	20	1	12	23	4	15	26	7	18	29	10	21	2
March 28	C	15	26	7	18	29	10	21	2	13	24	5	16	27	8	19	0	11	22	3
March 29	D	16	27	8	19	0	11	22	3	14	25	6	17	28	9	20	1	12	23	4
March 30	E	17	28	9	20	1	12	23	4	15	26	7	18	29	10	21	2	13	24	5
March 31	F	18	29	10	21	2	13	24	5	16	27	8	19	0	11	22	3	14	25	6
April 1	G	19	0	11	22	3	14	25	6	17	28	9	20	1	12	23	4	15	26	7
April 2	A	20	1	12	23	4	15	26	7	18	29	10	21	2	13	24	5	16	27	8
April 3	B	21	2	13	24	5	16	27	8	19	0	11	22	3	14	25	6	17	28	9
April 4	C	22	3	14	25	6	17	28	9	20	1	12	23	4	15	26	7	18	29	10
April 5	D	23	4	15	26	7	18	29	10	21	2	13	24	5	16	27	8	19	0	11
April 6	E	24	5	16	27	8	19	0	11	22	3	14	25	6	17	28	9	20	1	12
April 7	F	25	6	17	28	9	20	1	12	23	4	15	26	7	18	29	10	21	2	13
April 8	G	26	7	18	29	10	21	2	13	24	5	16	27	8	19	0	11	22	3	14
April 9	A	27	8	19	0	11	22	3	14	25	6	17	28	9	20	1	12	23	4	15
April 10	B	28	9	20	1	12	23	4	15	26	7	18	29	10	21	2	13	24	5	16
April 11	C	29	10	21	2	13	24	5	16	27	8	19	0	11	22	3	14	25	6	17
April 12	D	0	11	22	3	14	25	6	17	28	9	20	1	12	23	4	15	26	7	18
April 13	E	1	12	23	4	15	26	7	18	29	10	21	2	13	24	5	16	27	8	19
April 14	F	2	13	24	5	16	27	8	19	0	11	22	3	14	25	6	17	28	9	20
April 15	G	3	14	25	6	17	28	9	20	1	12	23	4	15	26	7	18	29	10	21
April 16	A	4	15	26	7	18	29	10	21	2	13	24	5	16	27	8	19	0	11	22
April 17	B	5	16	27	8	19	0	11	22	3	14	25	6	17	28	9	20	1	12	23
April 17	B	5	16	27	8	19	0	11	22	3	14	25	6	17	28	9	20	1	12	23
April 17	B	5	16	27	8	19	0	11	22	3	14	25	6	17	28	9	20	1	12	23
April 18	C	6	17	28	9	20	1	12	23	4	15	26	7	18	29	10	21	2	13	24
April 18	C	7	18	29	10	21	2	13	24	5	16	27	8	19	0	11	22	3	14	25

if on a Saturday, B is the Sunday Letter, and so on in a retrograde order; the letter which indicates the first Sunday in the year indicating it throughout, except in Leap Year. In Leap Year the letter which indicates the first Sunday of the year indicates it up to the end of February only; and from March onward to the end of the year the next letter backward is taken, so that if B is the Sunday Letter for January and February in Leap Year, A is that for the succeeding months; and G for the year following. The days of the year recur on the same days of the week throughout only after the lapse of twenty-eight years. The cycle of Sunday Letters extends therefore over this period, as may be seen in "the Table of Moveable Feasts for the remainder of the nineteenth century." It is sometimes, but erroneously, called the "Solar Cycle," the name having doubtless arisen from "Dies Solis," as the cycle has no relation to the course of the Sun.

§ *The Golden Numbers.*

This title was given to the Lunar Cycle invented by Meton the Athenian [B.C. 432], which was called after him the Metonic Cycle, and was anciently written in letters of gold, and

hence received its name. It extends over nineteen years, which are numbered respectively from 1 to 19. These were formerly marked throughout the year in the first column of the Calendar; but since 1752 they have been inserted only beside those days which are included within the Paschal full moon limits, i.e., between March 21st and April 25th. At the end of the cycle the phases of the moon begin to recur upon the same days of the month, in the same succession, with a difference of one hour and a half. This difference so far disturbs the application of the cycle of Golden Numbers that it will have to be re-adjusted in the year 1900, and one of the foregoing Tables is already provided for the purpose of making the necessary alteration.

The Golden Numbers in the Calendar indicate the day on which the Ecclesiastical Paschal Full Moon occurs; the Sunday Letter next after indicating (as has been already shown) the Festival of Easter itself.

The three "General Tables" are only of use to those who have to make historical calculations, and all might well be left to the Act of Parliament, and to works on Chronology, but they have been printed here in deference to the custom which has placed them in all our Prayer Books for some time past.

INTRODUCTION TO THE CALENDAR.

THE Ecclesiastical Calendar comprises two things: first, a table of the order of days in the year; and, secondly, a catalogue of the saints commemorated in the Church. To this, in the Book of Common Prayer, there is also annexed a table of the daily lessons throughout the year.

Calendars are known to have been in use at a very early date in the Church. One was printed by Bouchier in his Commentary on the Paschal Cycle [Antwerp, 1634], which was formed about the middle of the fourth century, or perhaps as early as A.D. 336; and another is given by Mabillon in his *Analecta*, which was drawn up for the Church of Carthage, A.D. 483. Many others are preserved of early times, and a number are printed by Martene in the sixth volume of his Collection of Ancient Writers.

The origin of Christian Calendars is clearly coeval with the commemoration of martyrs, which began at least as early as the martyrdom of Polycarp, A.D. 168. [Euseb. iv. 15.] The names of these, and their acts, were carefully recorded by the Church in Martyrologies; and Diptychs—tablets of wood or ivory—were inscribed with their names, to be read at the time when the memorial of the departed was made at the celebration of the Holy Eucharist. From one or both of these, lists of names would naturally be transcribed for use at other times, and as a memorial in the hands of private Christians, the names being placed against the day on which the martyrs suffered, or that (generally the same) on which they were annually commemorated. To these two columns of the days of the year and the names of the martyrs were afterwards added two others of Golden Numbers and Sunday Letters, the use of which has been explained in the notes to the Tables.

Several very ancient English Calendars exist in our public libraries; but the earliest known is one printed by Martene [Vet. Scrip. vi. 635], under the title "Calendarium Floriacense," and attributed by him (with apparently good reason) to the Venerable Bede, with whose works it was found in a very old MS. at Fleury. Bede died at Jarrow, A.D. 735, so that this Calendar must date from the earlier half of the eighth century. There is a general agreement between this Calendar and the Martyrology of Bede which seems to show that it is rightly attributed to him, and we may therefore venture to take it as the earliest extant Calendar of the Church of England, dating it from the latest year of Bede's life.

In the course of ages the number of names recorded in the Martyrologies of the Church increased to a great multitude, as may be seen in the vast folio "Acta Sanctorum," printed for every day of the year by the Bollandists, which was commenced two hundred and twenty years ago, and is not yet nearly complete, though it extends to fifty-eight volumes. The Calendars of the Church also began to be crowded, although there was always a local character about them which did not belong to the Martyrologies. In the twelfth century the original method of recording the names of saints (which was by the Bishop of each Diocese in some cases, and in others by a Diocesan Council) was superseded by a formal rite of Canonization, which was performed only by the Popes; and from this time the names inserted in the Calendar ceased to be those of Martyrs or Confessors only.

The Calendar of the Church of England was always local in its character, and one of the eleventh or twelfth century, which is preserved in the Durham Chapter Library, seems to differ but little from another of the fifteenth century, which is contained in an ancient Missal of that Church, or from that which has been reprinted from a Missal of 1514, belonging to Bishop Cosin's Library, in the following pages. Comparatively few names were added to the English Calendars during the mediæval period, though many were added to the Roman.

Some changes were made in the Calendar by the "Abrogation of certain Holydays" in the reign of Henry VIII., great inconvenience being found to arise from the number of days which were observed with a cessation from labour; and the two days dedicated to St. Thomas of Canterbury being especially obnoxious to the King were altogether expunged, though by very questionable authority.

When the English Prayer Book was set forth in 1549, it was thought expedient to insert only the chief of the names which had been contained in the Calendar of the Salisbury Use. Two of these were taken away (though the erasure of St. Barnabas was probably a printer's error), and four others added in 1552. In the following year, 1553, the old Salisbury Calendar was reprinted (with three or four omissions) in the Primer of Edward VI., and in the "Private Prayers" of Queen Elizabeth's reign, printed in 1584; but not in any Book of Common Prayer. In 1559 the Calendar of 1552 was reprinted with one omission.

It seems now to have been felt by persons in authority, that greater reverence ought to be shown for the names of those who had glorified God in a special manner by their deaths or their lives, and in the Latin Prayer Book of 1560 nearly every day of the year was marked by the name of a saint, the list being compiled from the old Salisbury Calendar and the Roman. This appears to have led to the appointment of a Commission, which met in 1561, and, with a few changes in the Tables and Rules, made also a revision of the list of Saints, bringing it into its present state, with two exceptions, the names of St. Alban and the Venerable Bede having been added since. These successive changes (as far as is necessary to illustrate the transition from the ancient to the modern Calendar) are represented in the following Table:—

§ Transition of the English Calendar, from 1549 to 1559.

Circumcision.	}	In Calendars of 1549, 1552, 1559.	
Epiphany.			
Conversion of St. Paul.			
Purification of the Blessed Virgin Mary.			
St. Matthias.			
Annunciation of the Blessed Virgin Mary.			
St. Mark.			
— Philip and St. James.			
— John Baptist.			
— Peter.			
— James.			
— Bartholomew.			
— Matthew.			
— Michael.			
— Luke.			
— Simon and St. Jude.			
All Saints.			
St. Andrew.			
— Thomas.			
Christmas.			
St. Stephen.			
— John Evangelist.			
Innocents.	}	In Calendar of 1549 only.	
St. Mary Magdalen.			
— Clement.			1552 only.
— Barnabas.			1549 and 1559.
— George.			
— Laurence.	}	1552 and 1559.	
Lammas.			

From the early part of Queen Elizabeth's reign [1561], until the present day, only three additions have been made to the Saints commemorated by the Church of England; those three being the national saints, St. Alban and the Venerable Bede, previously mentioned, and St. Enurchus. These three names, together with the particular designations by which most of the Saints in the Calendar are now distinguished, are to be found in the Calendar prefixed to Bishop Cosin's Devotions: and, as the first published edition of that work was printed in 1627, we may conclude that they were taken thence into the Book of Common Prayer at the Revision of 1661, as some of the Tables and Rules were.

No records remain to show what was the principle adopted in

the re-formation of the Calendar in Queen Elizabeth's reign: but the list of names in itself elucidates that principle to a certain extent, as the following Table will show. It seems a singular omission that the names of two of our greatest national saints, St. Aidan and St. Cuthbert, should have been overlooked, both in 1561 and in 1661. The omission of St. Patrick is almost as extraordinary; and it might have been expected that St. Thomas of Canterbury's name would have been restored when the bitterness of the Tudor times had passed away. The latter two names were always inserted in ordinary Almanacks, which were not bound up with the Prayer Book, and are also found in some Calendars of Queen Elizabeth's time.

§ Saints commemorated by the Church of England.

The Holy Apostles, &c.	Martyrs in the Age of Persecutions.		Martyrs and other Saints specially connected with England.		French and other Saints not included among the preceding.	
		A.D.		A.D.		A.D.
The Blessed Virgin Mary.	St. Nicomede	90	St. George, M. . . .	290	St. Silvester	335
St. Michael and all Angels.	St. Clement	100	St. Alban, M. . . .	303	St. Enurchus	340
All Saints.	St. Perpetua	203	St. Nicolas	326	St. Hilary of Poitiers, } Confessor	368
St. John the Baptist.	St. Cecilia	230	St. Benedict	543	St. Ambrose	
St. Peter.	St. Fabian	250	St. David	544	St. Martin	397
St. James the Great.	St. Agatha	251	St. Machutus	560	St. Jerome	420
St. John the Evangelist.	St. Lawrence	258	St. Gregory	604	St. Augustine	430
St. Andrew.	St. Cyprian	258	St. Augustine of } Canterbury	604	St. Britius	444
St. Philip.	St. Valentine	270	St. Etheldreda		670	St. Remigius
St. Thomas.	St. Denys	272	St. Chad	673	St. Leonard, Confessor	559
St. Bartholomew.	St. Prisca	275	St. Giles	725	St. Lambert	709
St. Matthew.	St. Margaret	278	Venerable Bede	735		
St. James the Less.	St. Lucian	290	St. Boniface	755		
St. Simon Zelotes.	St. Faith	290	St. Swithun	862		
St. Jude.	St. Agnes	304	St. Edmund, K. & M.	870		
St. Matthias.	St. Vincent	304	St. Edward, K. & M.	978		
St. Paul.	St. Lucy	305	St. Dunstan	988		
St. Barnabas.	St. Catharine	307	St. Alphege, M. . . .	1012		
St. Mark.	St. Crispin	308	St. Edward, K. & Conf.	1163		
St. Luke.	St. Blasius	316	St. Hugh	1200		
St. Stephen.			St. Richard	1253		
The Holy Innocents.						
St. Mary Magdalen.						
St. Anne.						

In Calendars of the Church of England not printed in the Prayer Book, but published by the Stationers' Company under the authority of the Archbishop of Canterbury¹, the following names are also to be found:—St. Patrick, St. Thomas of Canterbury, and All Souls. King Charles the First was likewise included among the Martyrs in all English Calendars until the special Form of Prayer for the 30th of January was given up in 1859.

It will be seen that the whole number of individual Saints commemorated is seventy-three. Of these, twenty-one are especially connected with our Blessed Lord; twenty-one are Martyrs in the age of persecutions; twenty-one are specially connected with our own Church; and eleven are either great and learned defenders of the Faith, like St. Hilary and St. Augustine, or Saints of France, whose names were probably retained as a memorial of the ancient close connexion between the Churches of France and England.

The Calendar itself was not in any way altered by the Act of Parliament of 1752, for the alteration of the style, the present tables of the months being a fairly exact reprint of those in the

¹ This authority continued to be given as late as 1832.

Sealed Books. They are here given from the Act, but are inserted after the Tables and Rules as in the Sealed Books. This order was evidently adopted with the object of making a definite Festival and Ferial division of this part of the Prayer Book, instead of confusing the two divisions together as in the Act; and while the improved text of the latter has been adopted, it has been thought better to take the more convenient and more ecclesiastical arrangement (in this respect) of the former.

In the "comparative view" of each of the months, all the names in that of Bede, the Salisbury Use of 1514, and the Modern Roman, are represented: but a selection only has been made from the Oriental Calendar, as the great majority of Eastern Saints are unknown to English readers, and their names would convey no information whatever. Those selected are chosen for the object of illustrating the points of similarity between the Calendars of East and West; and they are taken from the Byzantine Calendar printed in Neale's Introduction to the History of the Holy Eastern Church, vol. ii. p. 768. Some remarkable coincidences may be observed between it and the Calendar of Bede, which help to confirm the theory of a direct connexion between England and the Oriental Church.

* JANUARY hath 31 Days.

			Morning Prayer.		Evening Prayer.	
			1 Lesson.	2 Lesson.	1 Lesson.	2 Lesson.
1	A	Calendæ.				
2	b	4. Non.	Gen. 1	Matt. 1	Gen. 2	Rom. 1
3	c	3. Non.	3	2	4	2
4	d	Prid. Non.	5	3	6	3
5	e	Nonæ.	7	4	8	4
6	f	8. Id.				
7	g	7. Id.	9	5	12	5
8	A	6. Id.	13	6	14	6
9	b	5. Id.	15	7	16	7
10	c	4. Id.	17	8	18	8
11	d	3. Id.	19	9	20	9
12	e	Pr. Id.	21	10	22	10
13	f	Idus.	23	11	24	11
14	g	19. Cal. Feb.	25	12	26	12
15	A	18. Cal.	27	13	28	13
16	b	17. Cal.	29	14	30	14
17	c	16. Cal.	31	15	32	15
18	d	15. Cal.	33	16	34	16
19	e	14. Cal.	35	17	37	1 Cor. 1
20	f	13. Cal.	38	18	39	2
21	g	12. Cal.	40	19	41	3
22	A	11. Cal.	42	20	43	4
23	b	10. Cal.	44	21	45	5
24	c	9. Cal.	46	22	47	6
25	d	8. Cal.				
26	e	7. Cal.	48	23	49	7
27	f	6. Cal.	50	24	Exod. 1	8
28	g	5. Cal.	Exod. 2	25	3	9
29	A	4. Cal.	4	26	5	10
30	b	3. Cal.	† 6	27	7	11
31	c	Pr. Cal.	8	28	9	12

† Note, that Exod. 6 is to be read only to verse 14.

Comparative View of the Calendar for JANUARY.

	Bede, A.D. 735.	Salisbury Use, A.D. 1514.	Modern Roman.	Eastern.
1	Circumcision.	Circumcision.	Circumcision.	Circumcision. St. Basil.
2				St. Silvester.
3				Malachi, Prophet.
4				
5		St. Edward.	St. Telesphorus.	
6	Epiphany.	Epiphany.	Epiphany.	Theophany of our Lord.
7				St. John Baptist.
8		St. Lucian.		
9				
10	St. Paul the first Hermit.		St. Hyginus.	St. Gregory of Nyssa.
11				
12				
13	St. Hilary of Poitiers.			
14	St. Felix.	St. Felix.	SS. Hilary and Felix.	
15		St. Maurus.	St. Paul the first Hermit.	SS. Paul and John.
16	St. Marcellus.	St. Marcellus.	St. Marcellus.	St. Peter's Chains.
17	St. Anthony.	SS. Sulpicius and Anthony.	St. Anthony. [Prisca.	St. Anthony.
18	St. Prisca.	St. Prisca.	St. Peter's Chair at Rome and St.	SS. Athanasius and Cyril.
19		St. Wolstan.	SS. Wolstan, Marius, Martha, Audifax, and Abachum.	
20	St. Sebastian.	SS. Fabian and Sebastian.	SS. Fabian and Sebastian.	
21	St. Agnes.	St. Agnes.	St. Agnes.	
22	St. Vincent.	St. Vincent.	SS. Vincent and Anastasius.	St. Timothy, Apostle.
23			Espousals of B. V. Mary. St.	
24			St. Timothy. [Emerentiana.	
25		Conversion of St. Paul.	Conversion of St. Paul.	St. Greg. Nazianzen.
26			St. Polycarp.	
27		St. Julian.	St. John Chrysostom.	Translation of St. Chrysos-
28	St. Agnes.	St. Agnes.	SS. Raymond and Agnes.	[tom.
29			St. Francis of Sales.	Translation of St. Ignatius.
30		St. Bathilda.	St. Martina.	
31			St. Peter Nolasco.	

8] ST. LUCIAN is commemorated (like several other Saints of the Calendar) as a member of the early French or Gallican Church, between which and the early Church of England, with which the existing Calendar originated, there was a very close spiritual bond. He was originally a Roman nobleman, but being ordained priest, he became one of a devoted band of missionaries who were sent from Rome into France with St. Denys and St. Quintin, about A.D. 245. St. Denys went to the city of Paris, St. Quintin to Amiens, and St. Lucian to Beauvais, of which cities respectively they probably became the bishops, St. Lucian having the episcopal title assigned to him in a martyrology of the ninth century. After a bold missionary career of many years, St. Lucian was added to the noble army of martyrs, A.D. 290. He is often called St. Lucian of Beauvais, to distinguish him from another Lucian who was a learned predecessor of St. Jerome in Biblical criticism.

13] ST. HILARY was another French bishop. He was born at Poitiers, of heathen parents; and was converted and baptized in mature years: after which, in A.D. 350, he became Bishop of his native city. St. Hilary entered the lists against Arianism, endeavouring to persuade the Emperor Constantius to give up his patronage of it. Several French bishops became Arians, and held a Synod at Languedoc, where Hilary withstood them, and maintained the Nicene faith. His opposition was for the time ineffectual; and he was thrust out of his see, being also banished to Phrygia by the Emperor, in A.D. 356. The great majority of the Gallican bishops remained steadfast, and it is observable that the British bishops are also commended by St. Hilary for continuing so in his History of Synods. He returned to France about A.D. 360, contending as earnestly as before for that true doctrine of our Lord's Divinity and the Holy Trinity for which he had suffered, and about which he had written a learned treatise during his exile. After a journey to Italy, St. Hilary departed to his rest on Jan. 13, A.D. 368.

This saint is usually represented in Christian art as treading on serpents, in reference to his contest with the venomous heresy of Arius; and Numbers xxi. 7, the petition of the Israelites to Moses that he would pray for the serpents to be taken from them, is annexed as a significant legend.

"Hilary term" in the law courts used to begin on this festival, Advent and Christmas-tide being observed as a vacation of peace; but it now begins on Jan. 11th, extending to Jan. 31st.

18] ST. PRISCA was a young Roman lady of the third century, who "came out of great tribulation" by the sword at a very early age. Some true tale of Christian faith, fortitude, and suffering underlies the uncertain history which tells us that St. Prisca was thrown to the lions in the amphitheatre, that they knelt at her feet refusing to harm her, that she was then beheaded, and that an eagle watched over her lifeless form until it was laid in the grave. In accordance with this legend, St. Prisca is represented with a palm branch, or a sword in her hand, a lion couching at her feet, and an eagle hovering above her head. [Sar. Ep. and Gosp.: Ecclus. li. 9—12. St. Matt. xiii. 44—52.]

20] ST. FABIAN was one of that long series of martyred Bishops of Rome by which the church of St. Peter and St. Paul was distinguished above all others in the first three centuries. Eusebius [vi. 29] says that he was elected in consequence of a dove alighting on his head while the election was going on, and also of an irresistible unanimity pointing the thoughts of all to Fabian. This was in the year 236, when his predecessor had died a martyr after a single month's occupation of the see. A similar story to this of the dove is told respecting others; and it probably represents in a materializing allegory the idea that the promise of the presiding Comforter was fully realized in the assembly. St. Cyprian's ninth Epistle is written to the Roman Church respecting the martyrdom of St. Fabian, which occurred under the Emperor Decius, A.D. 250. It is also mentioned by St. Jerome; and the name is found in very ancient martyrologies. In the Eastern Church it is commemorated on Aug. 5th. Christian art represents him with the triple crown, holding the sword of martyrdom in his hand, and having a dove hovering above him. [Sar. Ep. and Gosp.: Heb. xi. 33—39. St. Luke vi. 17—23.]

21] ST. AGNES left a name behind her which was very much cherished by the early Church. She was a young Roman lady of patrician birth, who was sought—not, probably, in honourable marriage—by the son of the Prefect of the city, A.D. 304. Her refusal to accede to his desires brought upon her the full force of the brutal heathenism which characterized the age of martyrdoms. Before the Prefect she made an open confession that she was a Christian, making the sign of the Cross, instead of offering incense to Vesta, as she was required to do for the renunciation of Christianity. The holy maiden was then vilely disrobed and tortured on the rack; and after vain endeavours to bring about her apostasy, was at last beheaded. The circumstances of her death made a great impression upon the Christian world, for St. Jerome says that the tongues and pens of all nations were employed in praise of her constancy; and her memory has ever since his time been greatly venerated. It was recorded that while her parents were praying at her tomb (probably in the catacombs) she appeared to them in vision, and spoke words of comfort to them respecting her rest and peace with her Saviour. St. Augustine speaks touchingly of her name: "Blessed is the holy Agnes, whose passion we this day celebrate: for the maiden was indeed what she was called; for in Latin Agnes signifies a lamb; and in Greek it means pure. She was what she was called; and she was found worthy of her crown." This shows the antiquity of the Holyday.

The symbolical form of her name is used by Christian art in representations of St. Agnes, a lamb standing by her side, while she bears a palm-branch or a sword in her hand.

Several churches are dedicated in the name of St. Agnes in England. One built over her resting-place near Rome has attained a kind of historical importance, from the Pope going there annually to bless the lambs whose fleeces are ultimately to form the palls with which he claims to invest all Archbishops. Such a pall is seen in the arms of the Archbishop of Canterbury. [Sar. Ep. and Gosp.: Ecclus. li. 1—8. St. Matt. xiii. 44—52.]

22] ST. VINCENT was a martyr of Spain in that most terrible persecution under the Emperor Diocletian, which he commemorated by a coin with the inscription "*Nomine Christianorum deleto*," but which only caused the name of Christ to shine more brightly in Spain and elsewhere. St. Vincent was a deacon to Valerius, Bishop of Saragossa. Both were brought before Datian, the Prefect of Spain, and endured much suffering at his hands, being nearly starved to death, that they might afterwards be added to the number of those who "shall hunger no more, neither thirst any more . . . for the Lamb which is in the midst of the throne shall feed them, and shall lead them unto living waters." The Bishop was sent into exile, afterwards to die a martyr. Vincent was first tortured on the rack; and being still immovable in his faith, was then laid on a bed of sharp iron bars under which a fire had been lighted. Being removed from this before death had ended his sufferings, he departed in peace, surrounded by his Christian brethren, on Jan. 22, A.D. 304.

The account of St. Vincent's martyrdom, or his "Acts," has come down to us in an authentic form and with much detail. St. Augustine and St. Leo both refer to them; and this holyday was probably established very shortly after it occurred.

St. Vincent is represented with the bed or gridiron on which he was tortured; and also with a raven hovering near him, significant of the fact that his body was cast to the beasts of the field and the fowls of the air by heathen vengeance. [Sar. Ep. and Gosp.: Ecclus. xiv. 20, and xv. 4—6. St. John xii. 24—26.]

30] This holyday was originally established by a Royal Proclamation of Charles II. The Service for the day was, however, prepared and authorized by Convocation in the same manner as the Prayer Book itself. There were three separate editions of this Service or "Form of Prayer;" one issued in 1660, another in 1661, and a third in 1662, the latter being inserted in the Prayer Book in conformity with an order written at the end of the Sealed Books, in which it was not printed. The commemoration of King Charles the First's martyr-like death was abolished by a Royal Proclamation, dated Jan. 17, 1859, and since that date the Service has not been printed in the Prayer Book.

FEBRUARY hath 28 Days.
And in every Leap Year 29 Days.

				Morning Prayer.		Evening Prayer.	
				1 Lesson.	2 Lesson.	1 Lesson.	2 Lesson.
1	d	Calendæ.		Exod. 10	Mark 1	Exod. 11	1 Cor. 13
2	e	4. Non.	Purification of Mary.		2		14
3	f	3. Non.	Blasius, Bishop and Martyr.	12	3	13	15
4	g	Pr. Non.		14	4	15	16
5	A	Nonæ.	Agatha, Sicilian Virgin and Martyr.	16	5	17	2 Cor. 1
6	b	8. Id.		18	6	19	2
7	c	7. Id.		20	7	21	3
8	d	6. Id.		22	8	23	4
9	e	5. Id.		24	9	32	5
10	f	4. Id.		33	10	34	6
11	g	3. Id.		Levit. 18	11	Levit. 19	7
12	A	Pr. Id.		20	12	26	8
13	b	Idus.		Num. 11	13	Num. 12	9
14	c	16. Cal. Mar.	Valentine, Bishop and Martyr.	13	14	14	10
15	d	15. Cal.		16	15	17	11
16	e	14. Cal.		20	16	21	12
17	f	13. Cal.		22	Lu. 1 to 39	23	13
18	g	12. Cal.		24	1. 39	25	Galat. 1
19	A	11. Cal.		27	2	30	2
20	b	10. Cal.		31	3	32	3
21	c	9. Cal.		35	4	36	4
22	d	8. Cal.		Deut. 1	5	Deut. 2	5
23	e	7. Cal.		3	6	4	6
24	f	6. Cal.	S. Matthias, Apostle & Martyr.		7		Ephes. 1
25	g	5. Cal.		5	8	6	2
26	A	4. Cal.		7	9	8	3
27	b	3. Cal.		9	10	10	4
28	c	Pr. Cal.		11	11	12	5
29				13	Matt. 7	14	Rom. 12

Comparative View of the Calendar for FEBRUARY.

	Bede, A.D. 735.	Salisbury Use, A.D. 1514.	Modern Roman.	Eastern.
1		St. Bridget.	St. Ignatius.	
2	Purification of B. V. M.	Purification of B. V. M.	Purification of Blessed Virgin Mary.	Hypapante of our Lord.
3		St. Blasius.	St. Blase.	
4			St. Andrew Corsini.	
5	St. Agatha.	St. Agatha.	St. Agatha.	St. Agatha.
6		SS. Vedast and Amandus.	St. Dorothy.	
7			St. Romuald.	
8			St. John of Matha.	Zachariah the Prophet.
9			St. Apollonia.	
10		St. Scholastica.	St. Scholastica.	
11		Translation of St. Frides- [wide.		St. Blasius.
12				
13				
14	St. Valentine.	St. Valentine.	St. Valentine.	
15			SS. Faustinus and Jovita.	St. Onesimus, Apostle.
16	St. Juliana.	St. Juliana.		Pamphilus and his Com- [panions.
17				
18			St. Simeon.	St. Leo.
19				St. Archippus, Apostle.
20				
21				
22		St. Peter's Chair.	St. Peter's Chair at Antioch.	SS. Andronicus and Junia.
23			St. Peter Damian.	St. Polycarp.
24	St. Matthias.	} St. Matthias.	} St. Matthias.	
25				
26				
27				
28				
29				

THE MINOR HOLYDAYS OF FEBRUARY.

3] ST. BLASIVS was Bishop of Sebaste, now Szivas, of which city he is considered to be the tutelar Saint. He is said to have been a zealous supporter of the Christians in the Diocletian persecution, and himself to have suffered martyrdom [A.D. 316] under Licinius, by command of Agricolaus, the local governor. After having had his flesh cruelly torn by scourges and an iron wool-comb, he was beheaded. He has for ages been esteemed by the wool-combers as their patron saint, and they had guilds dedicated in his name at Norwich and in several places in Yorkshire and elsewhere. There are still some ancient traditional observances in the seats of the woollen manufacture, though the primitive occupation of hand-combing has almost died out. It is not uncommon there to see "Bishop Blaze" in full episcopal vestments as the sign of an inn. There are only three or four churches dedicated to him in England. His distinguishing emblem is an iron wool-comb; occasionally some or other of the legends connected with him are represented. [Sar. Ep. and Gosp.: Heb. v. 1—6. St. Matt. x. 26—32.]

5] ST. AGATHA was a native of Sicily, of noble birth, and was dedicated to God from her earliest years. She received the crown of martyrdom at Catania, triumphing over the most infamous assaults upon her fortitude and chastity, made at the instigation of Quintianus the consul, who availed himself of the edict of Decius against the Christians to seize upon both her person and

her estate. As she was being brought to trial, she wept, and prayed for courage and strength on the way, saying, "O Jesu Christ, Lord of all, Thou seest my heart, Thou knowest my desire, do Thou alone possess all that I am. I am Thy sheep, make me worthy to overcome the Evil One." After long endurance of the most horrible tortures, she fell asleep in Jesus about A.D. 251, commending her soul to the Divine keeping. Only three churches are dedicated in her name in England. Her distinguishing emblem is a breast held in a pair of pincers, or transfixed by a sword, and she is also represented with a clasped book and a palm-branch. Her name is one of those inserted in the canon of the old English Liturgies, and in that of Rome. It is also in the most ancient calendars both Eastern and Western. [Sar. Ep. and Gosp.: Ecclus. li. 1—8. St. Matt. xiii. 44—52.]

14] ST. VALENTINE was a priest who assisted the martyrs at Rome in the persecution under Claudius II. He was beaten with clubs, and beheaded after a year's imprisonment, on the 14th of February, about A.D. 270. His name occurs in the Sacramentary of St. Gregory and other ancient formularies. The custom of "choosing Valentines" seems to have had its origin in a heathen practice connected with the worship of Juno on or about this day; and the association of the popular absurdities with the day appears to be wholly accidental. [Sar. Ep. and Gosp.: Ecclus. xxxi. 8—11. St. Matt. xvi. 24—28.]

MARCH hath 31 Days.

				Morning Prayer.		Evening Prayer.	
				1 Lesson.	2 Lesson.	1 Lesson.	2 Lesson.
1	d	Calendæ.	David, Archbp. Menev.	Deut. 15	Luke 12	Deut. 16	Ephes. 6
2	e	6. Non.	Cedde or Chad, Bishop of Litchfield.	17	13	18	Phil. 1
3	f	5. Non.		19	14	20	2
4	g	4. Non.		21	15	22	3
5	A	3. Non.		24	16	25	4
6	b	Pr. Non.		26	17	27	Col. 1
7	c	Nonæ.	Perpetua, Maurit. Martyr.	28	18	29	2
8	d	8. Id.		30	19	31	3
9	e	7. Id.		32	20	33	4
10	f	6. Id.		34	21	Josh. 1	1 Thess. 1
11	g	5. Id.		Josh. 2	22	3	2
12	A	4. Id.	Gregor. M. B. of Ro. and C.	4	23	5	3
13	b	3. Id.		6	24	7	4
14	c	Pr. Id.		8	John 1	9	5
15	d	Idus.		10	2	23	2 Thess. 1
16	e	17. Cal. Apr.		24	3	Judg. 1	2
17	f	16. Cal.		Judg. 2	4	3	3
18	g	15. Cal.	Edward, King of West Saxons.	4	5	5	1 Tim. 1
19	A	14. Cal.		6	6	7	2, 3
20	b	13. Cal.		8	7	9	4
14	21	c	Benedict, Abbot.	10	8	11	5
3	22	d		12	9	13	6
23	e	11. Cal.		14	10	15	2 Tim. 1
11	24	f		16	11	17	2
25	g	10. Cal.	Annunciation of B. Virgin Mary. ^{Fast.}		12		3
19	26	A		18	13	19	4
8	27	b		20	14	21	Titus 1
28	c	9. Cal.		Ruth 1	15	Ruth 2	2, 3
16	29	d		3	16	4	Philem.
5	30	e		1 Sam. 1	17	1 Sam. 2	Heb. 1
31	f	8. Cal.		3	18	4	2

The Numbers here prefixed to the several Days, between the twenty-first day of March and the eighteenth day of April, both inclusive, denote the Days upon which those full Moons do fall, which happen upon or next after the twenty-first day of March, in those years of which they are respectively the Golden Numbers: And the Sunday Letter next following any such full Moon, points out Easter Day for that Year. All which holds until the Year of our Lord 1899 inclusive, after which Year the places of these Golden Numbers will be to be changed, as is hereafter expressed.

Comparative View of the Calendar for MARCH.

	Bede, A.D. 735.	Salisbury Use, A.D. 1514.	Modern Roman.	Eastern.
1		St. David.	St. David.	St. Eudocia.
2		St. Chad.	St. Chad.	
3				
4			St. Casimir.	
5				
6				
7			[Felicitas.	
8		SS. Perpetua and Felicitas.	SS. Thomas Aquinas, Perpetua, and	
9	The forty holy Martyrs.		St. Felix.	St. Theophylact. [baste.
10			St. Francis.	The forty Martyrs of Se-
11			The Forty Martyrs.	St. Quadratus and his Com-
12	St. Gregory.	St. Gregory.	St. John of God.	[panions.
13			St. Gregory the Great.	
14				St. Benedict.
15				
16				
17		St. Patrick.	St. Patrick.	
18		St. Edward the Martyr.	St. Gabriel, Archangel.	St. Cyril of Jerusalem.
19			St. Joseph.	
20	St. Cuthbert.	St. Cuthbert.	St. Cuthbert.	The Martyrs of Sabbas.
21	St. Benedict.	St. Benedict.	St. Benedict.	
22				
23				
24				
25	Annunciation of B. V. M.	Annunciation of B. V. M.	Annunciation of B. Virgin Mary.	Annunciation of B. V. M.
26				St. Gabriel, Archangel.
27				
28				
29				
30				
31				

1] ST. DAVID was the son of Xantus, prince of Ceretia, now Cardiganshire. He was religiously educated, and after his ordination to the priesthood embraced the ascetic life through the influence of Paulinus, a pupil of St. Germanus of Auxerre. After a long period of retirement in the isle of Vecta (? Wight) he set out, like St. Paul from Arabia, and preached the Gospel in Britain. He founded a monastery in the vale of Ross, which was celebrated for the austerity of its rule. In A.D. 519 he attended a synod of Welsh clergy, which met to condemn the then prevalent heresy of Pelagius. Here he so ably defended the truth that Dubritius, the aged archbishop of Caerleon, constrained him to become his successor: but he removed the see to Menevia, now called St. David's, after him. He is considered to be the patron saint of Wales, and he died about A.D. 544, in his eighty-third year. He is represented preaching on a hill, with a dove on his shoulder. [Sar. Ep. and Gosp.: Ecclus. xlv. 17, 20, 21—23; xlv. 6, 7, 15, 16. St. Matt. xxv. 14—23.]

2] ST. CHAD, together with his three brothers, Cedd, Bishop of London, and the priests, Alin and Cymbel, was trained under St. Aidan at Lindisfarne. He also studied in Ireland, whence he came to preside over a religious house, founded by his brother Cedd, in the Yorkshire wolds. He was consecrated to the see of York A.D. 666, by two British bishops, but soon resigned it in favour of Wilfrid, the two having, in consequence of a misunderstanding, been both consecrated to the same see. In A.D. 670, he was appointed Bishop of Lichfield, where he died of a plague in 673. Lichfield Cathedral, and thirty-one churches in the Midland counties, are dedicated in his honour. [Sar. Ep. and Gosp.: Ecclus. xlv. 1—5. St. Mark xiii. 33—37.]

7] ST. PERPETUA, ST. FELICITAS, and their three companions, suffered in the persecution by Severus about A.D. 203, in Africa. St. Perpetua was the wife of a man of rank, and was herself of good family. At the time of her martyrdom she had an infant at the breast. The "Acts of St. Perpetua" are supposed to have been partly written by herself before her death, and afterwards completed by Tertullian. They contain a very remarkable and detailed account of her sufferings. She was first tossed by a wild cow, which is often represented with her, and then slowly butchered by a timorous or unskilful executioner. The day occurs in a Roman calendar of the year 354, and the names are commemorated in the canon of the Roman Liturgy. [Sar. Ep. and Gosp.: 1 Cor. vii. 25—34. St. Matt. xxv. 1—13.]

12] ST. GREGORY, surnamed the Great, was born at Rome, of noble and wealthy parents, about A.D. 540. His education was of the highest class, and included civil and canon law. At the age of thirty-four he was made chief magistrate of Rome, and was obliged to live in great pomp and state. But all his sympathies were with the religious life, and after the death of his father he founded and endowed six monasteries in Sicily, out of the family estates in that island. He also founded a seventh, dedicated to St. Andrew, in his own house in Rome, in which he himself assumed the Benedictine habit at the age of thirty-five. Here he impaired his constitution by the rigour with which he fasted while he was studying. It is to this period of his life that the well-known story about the British slaves refers. He actually set off on a mission to England, but was recalled by Pope Benedict I, the whole city being in an uproar at his departure. Gregory was soon after this made a Cardinal-Deacon, and took a prominent part in public affairs. He was then chosen Abbot of the Monastery he had founded, and in A.D. 590 was elected Pope, and after having manifested the utmost reluctance was consecrated on the 13th of September. It was during the monastic period of his life that he wrote the celebrated "Morals on the Book of Job." In the fifth year of his Pontificate occurred the controversy regarding the title of Universal Bishop, which he regarded as Antichristian. In July, A.D. 596, he again took up his scheme for the conversion of England, and sent hither St. Augustine with forty companions, to whom, under God, we owe the revival of Christianity in the southern parts of our land. During the rest of his life St. Gregory gave himself much to study, and revised the Divine offices, paying much attention to their ancient music, which from this circumstance has acquired the

popular designation of *Gregorian*. He departed in peace, March 12, A.D. 604, and was buried in St. Peter's. St. Gregory is esteemed as one of the Four Doctors of the Western Church, and is represented with the triple crown as a Pope, and with a book in his hand, and a dove on his shoulder, as a Doctor aided by the Holy Spirit. His festival is kept in the Greek Church on the 11th of March, but its observance in England on the 12th was enjoined on the monasteries as early as A.D. 747, at the Synod of Cloveshoe, and on the kingdom generally at the Council of Oxford, A.D. 1222. [Sar. Ep. and Gosp.: Ecclus. xlvii. 8—11. St. Matt. xxiv. 42—47.]

18] ST. EDWARD THE KING succeeded his father King Edgar, at the age of thirteen, in A.D. 975. He was celebrated for his piety and the amiability of his disposition, which greatly endeared him to his subjects. After a reign of three years and a half, he was treacherously stabbed, while drinking the stirrup-cup, by order of his step-mother Elfrida, her object being to obtain the crown for her own son Ethelred. He had gone out of his way from hunting to pay her a visit, and to see his brother, whom he had always treated with affectionate kindness. He was buried deep in a marsh, after which his body was twice re-interred. [See June 20.] He is usually represented as a youthful king, with a cup in one hand and a dagger or sceptre in the other, and often with a falcon, in allusion to his last hunt. [Sar. Ep. and Gosp.: Ecclus. xxxi. 8—11. St. Luke xfv. 26—33.]

21] ST. BENEDICT, the founder of the great Benedictine order of Monks, was born of a good family resident at Nursia, in the Italian province of Umbria, about A.D. 480. He was educated in the great public schools at Rome, but was there so shocked at the licentiousness prevailing among the Roman youth, that he secretly quitted the city at the age of fifteen, and betook himself to a cavern at Subiaco, where he lived as a hermit for three years. He had before met with Romanus, a monk, who, during his retreat, supplied him with food. It was at this time that, when distracted by temptations, he used to roll himself in the briars, a circumstance familiar to many through its being mentioned in Bishop Taylor's "Holy Living." He gained such influence over the shepherds of the wild region round about, that some were persuaded by him to become monks. After much solicitation he consented to become Abbot of Vicobarro, near Subiaco, where he diligently endeavoured to reform the abuses that he found existing. This rendered him so unpopular with some of the inmates that they attempted to poison him; and, after praying God to forgive them, he returned to his cave. Here he had many disciples, and organized twelve religious houses, each containing a Superior and twelve monks. These were eventually united in the Monastery of St. Scholastica, the most ancient of the order, as is supposed. Having still many enemies, and being a man of peace, he again sought retirement, and repaired to Mount Cassino, where some of the ancient idolatrous rites still prevailed, and where stood an old temple of Apollo and a grove. Here he was the means of converting many to the faith of Christ. He overthrew the temple and cut down the grove, and upon the site founded two oratories. This was the origin of the celebrated Monastery of Mount Cassino, whence proceeded the "Benedictine Rule," and where the present monastic system of Western Europe was definitely organized. Towards the close of Benedict's life, his sister Scholastica came to reside near him, with a small community of religious women; where he used to visit her once a year. He died of a fever caught in visiting the poor. Feeling that his end was drawing near, he ordered his grave to be dug, and, supported by the brethren, contemplated it in silence for some time; and then being carried into the chapel, there expired on the eve of Passion Sunday, A.D. 543. He is represented in various monastic habits, according to circumstances, and often carries an open book with the first words of his Rule:—AVSCVLTA FILI VERBA MAGISTRI. Others of his distinguishing emblems are, the thorn-bush; a wine-cup, or loaf, with a serpent crawling out of it (in allusion to attempts made to poison him); and a broken sieve. [Sar. Ep. and Gosp.: Ecclus. xxxix. 5—9. St. Luke xi. 33—36.]

APRIL hath 30 Days.

				Morning Prayer.		Evening Prayer.	
				1 Lesson.	2 Lesson.	1 Lesson.	2 Lesson.
13	1	g	Calendæ.	1 Sam. 5	John 19	1 Sam. 6	Heb. 3
2	2	A	4. Non.	7	20	8	4
	3	b	3. Non.	9	21	10	5
10	4	c	Pr. Non.	11	Acts 1	12	6
	5	d	Nonæ.	13	2	14	7
18	6	e	8. Id.	15	3	16	8
7	7	f	7. Id.	17	4	18	9
	8	g	6. Id.	19	5	20	10
15	9	A	5. Id.	21	6	22	11
4	10	b	4. Id.	23	7	24	12
	11	c	3. Id.	25	8	26	13
12	12	d	Pr. Id.	27	9	28	James 1
1	13	e	Idus.	29	10	30	2
	14	f	18. Cal. Majj	31	11	2 Sam. 1	3
9	15	g	17. Cal.	2 Sam. 2	12	3	4
	16	A	16. Cal.	4	13	5	5
17	17	b	15. Cal.	6	14	7	1 Pet. 1
6	18	c	14. Cal.	8	15	9	2
	19	d	13. Cal.	10	16	11	3
	20	e	12. Cal.	12	17	13	4
	21	f	11. Cal.	14	18	15	5
	22	g	10. Cal.	16	19	17	2 Pet. 1
	23	A	9. Cal.	18	20	19	2
	24	b	8. Cal.	20	21	21	3
	25	c	7. Cal.	22	22	23	1 John 1
	26	d	6. Cal.	22	23	23	2
	27	e	5. Cal.	24	24	1 Kings 1	3
	28	f	4. Cal.	1 Kings 2	25	3	4
	29	g	3. Cal.	4	26	5	5
	30	A	Pr. Cal.	6	27	7	2, 3 John

Comparative View of the Calendar for APRIL.

	Bede, A.D. 735.	Salisbury Use, A.D. 1514.	Modern Roman.	Eastern.
1				St. Mary of Egypt.
2				
3		St. Richard.	St. Francis of Paula.	
4		St. Ambrose.	St. Richard.	
5			St. Isidore.	
6			St. Vincent Ferrer.	
7				St. Eutychius of Constan- [tinople.
8				
9	The seven Virgins.			SS. Herodion, Agabus, [Rufus, Asyncritus, [Phlegon, and Hermas. St. Antipas of Pergamus.
10			St. Leo the Great.	
11				
12			St. Hermenegild.	
13	SS. Tiburtius, Valerian, [and Maximus.	SS. Tiburtius, Valerian, [and Maximus.	SS. Tiburtius, Valerian, and Maxi- [mus.	St. Crescens.
14				
15			St. Anicetus.	
16				
17		St. Alphege.		
18				
19			St. Anselm.	St. Januarius and his Com- [panions.
20			SS. Soter and Caius.	
21			St. George.	St. George.
22	St. George.	St. George.	St. George.	
23		St. Mark.	St. Fidelis.	
24	St. Mark.	St. Mark.	St. Mark.	St. Mark.
25			SS. Cletus and Marcellinus.	[kinsman.
26				St. Symeon, the Lord's [Apostles.
27	St. Vitalis.	St. Vitalis.	St. Peter.	SS. Jason and Sosipater, St. James, the brother of [John, Apostle.
28				
29				
30		St. Erkenwald.		

3] ST. RICHARD was Bishop of Chichester about the middle of the thirteenth century. His parents, Richard and Alice de Wiche, resided on an estate near Worcester, to which he was heir. But from his earliest years he showed a strong inclination for study and devotion, and studied successively at Oxford, Paris, and Bologna. After having held the Professorship of Civil Law at Bologna for a short time, he returned to Oxford, and was made Chancellor of the University, and subsequently of the diocese of Canterbury; under St. Edmund, with whom he went into exile in France. Here he studied for a while in a Dominican convent, and it was not till this period of his life that he was ordained priest. Returning again to England, he served as a parish priest in the diocese of Canterbury, and resumed the office of Chancellor under Archbishop Boniface. The see of Chichester falling vacant, A.D. 1244, one of those disputes between King and Pope, which were then so common, arose about the appointment. The chapter elected one Robert Passelaw, Archdeacon of Chichester; but the Archbishop declined to confirm the election, as being that of an unfit person. He declared the nomination void, and appointed Richard de Wiche to the vacant see. The King then confiscated the revenues, and a strong party of courtiers and others set themselves against the new Bishop. He however appealed to Rome, and got a Papal decision in his favour, which naturally incensed the King all the more. The Bishop however applied himself diligently to the duties of his office, and in his case was fulfilled the text, "When a man's ways please the Lord, He maketh even his enemies to be at peace with him;" for, after two years, the King relented, and restored his lands. In A.D. 1253, he was preaching a crusade in the south of England, and when at Dover consecrated a church there, on Mid-Lent Sunday, in honour of his former patron, St. Edmund of Canterbury. While thus engaged he was seized with his last illness, and departed during the week following. Simon of Tarring, a Sussex gentleman, who had protected him during the displeasure of the King, and other friends, were present with him during his last hours. After lying in state for some days, his body was buried before the altar of St. Edmund, in Chichester Cathedral, and some years afterwards removed to a place of greater honour in the same church. He is represented as a Bishop, usually with a chalice at his feet; in allusion to a tradition that, in his old age, falling with the chalice, its contents were not spilled. [Sar. Ep. and Gosp.: Ecclus. xlv. 17. 20—23, and xlv. 6, 7. 15, 16. St. John xv. 1—7.]

4] ST. AMBROSE is commemorated on this, the day of his death, in accordance with English usage; but in the Latin and Greek Churches his feast is kept on the 7th of December, the day of his ordination. He was born about A.D. 340, in Gaul, where his father held the office of Prætorian Prefect. Paulinus affirms that while he was in his cradle a swarm of bees settled on his lips, and that this, as in the case of Plato, was thought to predict his future eloquence. After the death of his father he was educated at Rome, where he attained to great proficiency in Greek and Civil Law, which led to his appointment to the Governorship of Liguria. He also practised as an advocate, and displayed so much wisdom and judgment in this capacity during a severe contest between the orthodox and the Arians, relative to an appointment to the see of Milan, that he was, although as yet unbaptized, strongly pressed to accept the office himself—the whole multitude taking up the cry, "Ambrose is Bishop"—first uttered, it is said, by a child. He reluctantly consented, and, after baptism, was ordained and consecrated, Dec. 7, A.D. 374. Having made over to the church of Milan all his estates, he devoted himself to his duties. He had constant difficulties in consequence of the prevalence of the Arian and Apollinarian heresies, and wrote many theological works, both controversial and devotional. St. Ambrose is spoken of with the most affectionate reverence by St. Augustine in his Confessions, as having been greatly instrumental in the work of his conversion. The saying, "When I am at Rome, I do as they do at Rome," is attributed to St. Ambrose, who replied to St. Augustine, when he consulted him about the different modes of observing Saturday at Rome and Milan: "When I come to Rome I fast on the

Saturdays, as they do at Rome; when I am here I do not fast. So likewise you, to whatsoever Church you come, observe the custom of that place, if you mean not either to give or take offence."

But in matters which involved principle, St. Ambrose did not shrink from his duty. It is well known how he excommunicated the Emperor Theodosius, for a cruel abuse of power during an insurrection at Thessalonica; and how he shut the gates of the church of Milan against him, exhorting him with such effect that he became a true penitent. He is said to have introduced metrical hymns into the Offices of the Church, and, like St. Gregory, to have paid great attention both to the construction of these Offices, and to the music used in them, the "Ambrosian rite" having a very distinct character of its own, like the English. He is also reckoned as one of the four great doctors of the Western Church. He died, A.D. 397, on the 4th of April, and his body still lies under the high altar of the basilica dedicated to him at Milan. [Sar. Ep. and Gosp.: Ecclus. xlvii. 8—11. St. Matt. xxiv. 42—47.]

19] ST. ALPHEGE was an English saint. He was born of a noble family, about A.D. 954, and while very young retired to a monastery, and afterwards became abbot of a house at Bath. In 984 he was made Bishop of Winchester, and in 1006 translated to Canterbury. In 1011 the Danes broke in upon the city, and imprisoned the Archbishop, offering to set him free for the treasures of the church. He refused to give them up, and after having held out for several months, was stoned, and finally slain with a battle-axe, calling upon God, like St. Stephen, to receive his soul, and, like Christ, for the forgiveness of his murderers. This took place on the site of the present parish church of Greenwich, which is dedicated to him. His body was buried first in the Cathedral of St. Paul in London, but afterwards translated to Canterbury. He is represented as an Archbishop, with stones in his vestment, and sometimes with the battle-axe. [Sar. Ep. and Gosp.: Heb. xiii. 9—16. St. John xv. 1—7.]

23] The history of St. GEORGE of Cappadocia, the Patron of England, has been from time to time mixed up with that of George, the Arian bishop of Alexandria, and is so obscure that some have doubted his existence. But churches were dedicated to him under the first Christian Emperors, and his office is found in the Sacramentary of St. Gregory. The Greek Church calls him the Great Martyr, and keeps his festival as a holyday of obligation. He was born in Cappadocia in the latter half of the third century, of noble Christian parents, entered the army, and was rapidly advanced by the Emperor Diocletian. He was himself imprisoned, tortured, and beheaded: being, apparently, the same young man who tore down the edicts for persecution, as related by Lactantius and Eusebius. He was first acknowledged as the Patron of England at the Synod of Oxford, A.D. 1220, and has been regarded as the patron of military men, partly on account of his own profession, and partly because of his alleged appearance to Richard Cœur de Lion in his expedition against the Saracens. Hence, no doubt, the old battle-cry, "St. George for England!" Under his name King Edward the Third [A.D. 1330] instituted the Order of the Garter, the most ancient and most noble order of knighthood in Europe. The stalls and insignia of these knights are at St. George's Chapel, Windsor, where special prayers are offered for them in the Daily Service, as well as a special service on "Obit Sunday." St. George is usually represented in conflict with a dragon, in allusion to the legend of his having fought with a dragon to save the daughter of a king, though it may be better understood of the conflict of the Christian soldier with Satan on behalf of the Church. He is represented as a young warrior, fully armed, and bearing a red cross, on his shield or on a banner. This is the famous cross of St. George, and is incorporated with that of St. Andrew, the patron saint of Scotland, in the national flag called the "Union Jack." There are more than 162 churches of ancient foundation dedicated to St. George, and his name was retained in the Calendar in the time of Queen Elizabeth, when almost all the other "black-letter" saints had been struck out. [Sar. Ep. and Gosp.: St. James i. 2—12. St. John xv. 1—7.]

MAY hath 31 Days.

			Morning Prayer.		Evening Prayer.	
			1 Lesson.	2 Lesson.	1 Lesson.	2 Lesson.
1	b	Calendæ.	S. Philip and James, A. and M.		Jude	
2	c	6. Non.	1 Kings 8	Acts 28	1 Kings 9	Rom. 1
3	d	5. Non.	10	Matt. 1	11	2
4	e	4. Non.	12	2	13	3
5	f	3. Non.	14	3	15	4
6	g	Pr. Non.	16	4	17	5
7	A	Nonæ.	18	5	19	6
8	b	8. Id.	20	6	21	7
9	c	7. Id.	22	7	2 Kings 1	8
10	d	6. Id.	2 Kings 2	8	3	9
11	e	5. Id.	4	9	5	10
12	f	4. Id.	6	10	7	11
13	g	3. Id.	8	11	9	12
14	A	Pr. Id.	10	12	11	13
15	b	Idus.	12	13	13	14
16	c	17. Cal. Jun.	14	14	15	15
17	d	16. Cal.	16	15	17	16
18	e	15. Cal.	18	16	19	1 Cor. 1
19	f	14. Cal.	20	17	21	2
20	g	13. Cal.	22	18	23	3
21	A	12. Cal.	24	19	25	4
22	b	11. Cal.	Ezra 1	20	Ezra 3	5
23	c	10. Cal.	4	21	5	6
24	d	9. Cal.	6	22	7	7
25	e	8. Cal.	9	23	Neh. 1	8
26	f	7. Cal.	Augustine, first Archbp. of Canterbury. Neh. 2	24	4	9
27	g	6. Cal.	Ven. Bede, Pr. 5	25	6	10
28	A	5. Cal.	8	26	9	11
29	b	4. Cal.	King Charles II. Nat. and Ret. 10	27	13	12
30	c	3. Cal.	Esther 1	28	Esther 2	13
31	d	Pr. Cal.	3	Mark 1	4	14

Comparative View of the Calendar for MAY.

	Bede, A.D. 735.	Salisbury Use, A.D. 1514.	Modern Roman.	Eastern.
1	St. Philip.	SS. Philip and James.	SS. Philip and James.	Jeremiah the Prophet.
2			St. Athanasius.	St. Athanasius.
3		Invention of the Cross. SS. [Alexander and Eventius.	Finding of the Holy Cross. SS. [Alexander, Eventius, Theodulus, St. Monica. [Juvenal.	
4			St. Catharine of Sienna.	
5			St. John at the Latin Gate.	Job the Just (Patriarch).
6	Invention of the Cross. St. [Alexander and his com- St. Victor. [panions.	St. John, ante Port. Lat. St. John of Beverley.	St. Stanislaus.	The Sign of the Cross. [and Ev.
7			Apparition of St. Michael, Arch.	St. John the Divine, Apostle
8		Translation of St. Nicolaus.	St. Gregory Nazianzen.	Isaiah the Prophet.
9		SS. Gordian and Epimachus.	SS. Antoninus, Gordian, and Epima- St. Pius V. [chus.	St. Simon Zelotes, Apostle.
10	St. Gordian.		SS. Nereus, Achilleus, Domitilla, and [Pancratius.	The birthday of Constanti- [nople.
11	St. Pancras.	SS. Nereus, Achilleus, and [Pancras.	St. Boniface.	
12			St. John Nepomucen.	
13	St. Isidore.		St. Paschal Baylon.	SS. Andronicus and Junia.
14			St. Venantius.	
15			SS. Dunstan, Pudentiana.	
16		St. Dunstan.	St. Bernardine.	
17	St. Pudentiana.		St. Peter Celestine.	
18	St. Basil.		St. Ubaldus.	SS. Constantine and Helena.
19			[Christians.	
20		Feast of the Holy Saviour.	Our Blessed Lady, the Help of SS. Aldhelm, Bp. of Salisbury, and [Urban.	
21	St. Urban.	St. Aldhelm.	St. Augustine.	St. Carpus, Apostle.
22		St. Augustine, Apostle of [the English.	St. Philip Neri.	
23		St. Germanus.	St. Gregory VII.	
24				
25				
26				
27				
28				
29	St. Felix.			
30	St. Petronilla.	St. Petronilla.		
31				

3] **INVENTION OF THE CROSS.**—This festival commemorates the finding the Cross on which our Lord suffered, by the Empress Helena, about A.D. 326. At this time the Jews and Pagans together had effaced nearly every trace of the scenes of our Lord's Passion and Resurrection, the Holy Sepulchre had been paved over, and heathen temples built on the spot. It was supposed that the crosses of our Lord and of the two thieves were buried near the place where they suffered, and after a long and difficult search they were found. Macarius, Bishop of Jerusalem, in order to distinguish that of our Lord, suggested that the three crosses should be carried to a sick lady, and after much prayer applied them singly to her. By the touch of one of them the sick lady recovered, as those did to whom were brought handkerchiefs and aprons from St. Paul's body. The Empress, full of joy at the discovery, enclosed the precious relic in a silver shrine, and built on the spot a church in which it might be preserved. She also carried a large piece to Rome, and deposited it in a church which she had built there in honour of the Holy Cross. [See Sept. 14.] This account has not been disproved. [Sar. Ep. and Gosp.: Gal. v. 10—12, and vi. 12—14. St. John iii. 1—15.]

6] **ST. JOHN ANTE PORTAM LATINAM.**—This festival was instituted in memory of the miraculous deliverance of St. John from death, when he was cast into a cauldron of boiling oil before the Latin Gate of Rome, by order and perhaps in the presence of Domitian. Our Lord had promised that deadly things should not hurt those who believed in Him, and thus His word was fulfilled, as it had been before when St. Paul took up the serpent at Melita; and as it had been by anticipation when the form of the Son of God was seen walking with the three young men in the fiery furnace at Babylon. The Emperor attributed the Apostle's deliverance to the power of magic, and banished him to Patmos, where he received and recorded the Apocalypse. There has been a church at Rome on the spot where the event above mentioned occurred, ever since the time of the first Christian Emperors. The day is kept as a great festival at St. John's College, Cambridge, and at the more recent foundation of St. John's Hurstpierpoint. [Sar. Ep. and Gosp.: Eccl. xv. 1—6. St. John xxi. 19—24.]

19] **ST. DUNSTAN.**—This Saxon Saint was born about A.D. 924, at Glastonbury, of Christian parents holding a high position in society. He was educated in his native town, under a society of Irish monks there resident, and lived for some time with Athelmus, Archbishop of Canterbury, his uncle, who introduced him to the notice of King Athelstan. At court he for a time enjoyed the highest favours, but some who envied him maligned him to the King, and he was banished from the royal presence. He was then urged to take monastic vows by Alphege the Bald, Bishop of Winchester, and after a time became a monk, and was also ordained priest. He served the church at Glastonbury, dwelling in a small cell attached thereto. Here he fasted and prayed, and worked at copying and illumination, and at the fabrication of vestments, censers, and other church furniture. Athelstan was succeeded by his brother Edmund, who recalled Dunstan; but he soon again fell into disgrace at court, and retired to the Benedictine monastery of Fleury in France. After a few years he was recalled, and made Superior of the house at Glastonbury. Here he refounded the church and convent on a larger scale, established a rule based on that of St. Benedict, and became himself the first Abbot on the new foundation, and nineteenth from St. Brithwald. King Edmund after a reign of six years and a half was murdered, and his sons, Edwy and Edgar, being too young for the throne, his brother Edred succeeded him, and followed the advice of St. Dunstan in all things. He dying in 955, was succeeded by Edwy, a profligate youth, whose vices St. Dunstan was obliged to reprove even on the day of his coronation. In revenge he banished the Abbot, persecuted the Monks every where, and devastated all the abbeys that had been spared by the Danes except Glastonbury and Abingdon. After a year's exile in Flanders, Dunstan was recalled by Edgar, who had been placed on the throne instead of Edwy, deposed by the Mercians. This young King made Dunstan his principal counsellor, and in A.D. 957 he was made Bishop of Worcester, and shortly afterwards of London. Edwy still

reigned over the southern provinces for three years longer; but on his death Edgar became monarch of all England, and Dunstan was raised to the see of Canterbury, being also appointed Papal legate by Pope John XII. He exerted himself greatly in the restoration of discipline, and in conjunction with Ethelwold, Bishop of Winchester, and Oswald, Archbishop of York, re-established most of the chief monasteries. He exercised a rigid control over the secular clergy, ejecting many who were married, and enforcing celibacy on others. At one time King Edgar having fallen into a scandalous crime, he boldly reprov'd him, and brought him to repentance. He went about preaching and instructing the people in the churches of his diocese, and would sometimes repair to his old retreat at Glastonbury for solitude and contemplation. His last sickness came upon him at Canterbury, where, after preaching thrice on Ascension Day, A.D. 988, he died on the Saturday following, and was buried in his own cathedral. Some of his bones were said to have been translated to Glastonbury in 1012, but the greater part of them were found under his tomb in 1508. His distinguishing emblems are a pair of pincers and a harp. Six churches in Kent, six in Middlesex, and six elsewhere, are dedicated to him, including the well-known city churches of St. Dunstan near Temple Bar, and St. Dunstan in the East. [Sar. Ep. and Gosp.: Eccl. xlv. 47. 20, 21—23; xlv. 6, 7, 15, 16. St. Matt. xxv. 14—23. During Easter-tide, St. John xv. 1—7.]

26] **ST. AUGUSTINE,** the first Archbishop of Canterbury, has been called the Apostle of England, from the great work which he accomplished in restoring the Church in the south-east part of the country, after the old Clergy had been entirely rooted out by the Saxons. Nothing is known of his history until the time when he was sent on his mission by Gregory the Great. He was then Prior of St. Andrew's Monastery at Rome. [See March 12.] He landed in Kent A.D. 596, and went through the Isle of Thanet towards Canterbury, by invitation of King Ethelbert. The manner in which St. Augustine and his missionary brethren came towards the heathen King is thus recorded by the Venerable Bede: "He came chanting Litanies, and beseeching the Lord for the everlasting weal, as well of themselves, as of those for whose sake he had come. . . . And when they drew near that city, they chanted the Litany with one accord in these words;—'That it may please Thee to turn away the fury of Thy wrath from all Thy people, and chiefly from this city, we sinners beseech Thee to hear us, O Lord.' Then being admitted into the royal presence, they proclaimed their mission before the King: and he, having already some acquaintance with Christianity (through his wife Bertha, and her chaplain, Luidhard, Bishop of Senlis), received them kindly, and bade them welcome to his city." Kent had returned almost entirely to heathenism, and the coming of these missionaries was a great blessing to it. They restored to its proper use the old church of St. Martin, and thus made Christian worship familiar again to the eyes of the people. They converted large numbers of the Saxon conquerors, and eventually the King himself, who afterwards laboured earnestly for the perfect establishment of the Church among his people, during the twenty remaining years of his life.

But when the new missionaries extended their work into a wider circle, they came into contact with the ancient Church of England, of which in the conquered part of the island they had found only dormant remains. To men of polished education and exact ritual habits the ancient Church of the land presented features which were distasteful to them: and in their own fervent zeal and high prosperity, they seem to have appreciated at too low a value the energies of a depressed and persecuted Clergy. Augustine endeavoured to enforce a Roman ritual and jurisdiction upon the native Bishops; and this they resisted, claiming to possess independent Episcopal jurisdiction, and to have a ritual as Apostolic in its origin as that of Rome itself. These heart-burnings lasted until long after the death of St. Augustine, which happened A.D. 604; and tended in some degree to mar the good work which he had so well begun. Yet it cannot be doubted that England owes a debt of gratitude to him as a second founder of her Church, and the great see of Canterbury is an enduring monument of his missionary zeal. Dying on May 26th, 604,

JUNE hath 30 Days.

			Morning Prayer.				Evening Prayer.	
			1 Lesson.	2 Lesson.	1 Lesson.	2 Lesson.		
1	e	Calendæ.	Nicomede, Rom. Pr. and M.		Esther 5	Mark 2	Esther 6	1 Cor. 15
2	f	4. Non.			7	3	8	16
3	g	3. Non.			9	4	Job 1	2 Cor. 1
4	A	Pr. Non.			Job 2	5	3	2
5	b	Nonæ.	Boniface, Bishop of Mentz and M.		4	6	5	3
6	c	8. Id.			6	7	7	4
7	d	7. Id.			8	8	9	5
8	e	6. Id.			10	9	11	6
9	f	5. Id.			12	10	13	7
10	g	4. Id.			14	11	15	8
11	A	3. Id.	S. Barnabas, Apostle and Mart.					
12	b	Pr. Id.			16	12	17, 18	9
13	c	Idus.			19	13	20	10
14	d	18. Cal. Julii			21	14	22	11
15	e	17. Cal.			23	15	24, 25	12
16	f	16. Cal.			26, 27	16	28	13
17	g	15. Cal.	S. Alban, Martyr.		29	Luke 1	30	Galat. 1
18	A	14. Cal.			31	2	32	2
19	b	13. Cal.			33	3	34	3
20	c	12. Cal.	Transl. of Edward, King of West Sax.		35	4	36	4
21	d	11. Cal.			37	5	38	5
22	e	10. Cal.			39	6	40	6
23	f	9. Cal.	Fast.		41	7	42	Ephes. 1
24	g	8. Cal.	Nativity of S. John Baptist.					
25	A	7. Cal.			Prov. 1	8	Prov. 2	2
26	b	6. Cal.			3	9	4	3
27	c	5. Cal.			5	10	6	4
28	d	4. Cal.	Fast.		7	11	8	5
29	e	3. Cal.	S. Peter, Apostle and Mart.					
30	f	Pr. Cal.			9	12	10	6

Comparative View of the Calendar for JUNE.

	Bede, A.D. 735.	Salisbury Use, A.D. 1514.	Modern Roman.	Eastern.
1		St. Nicomede.		St. Justin Martyr and his
2		SS. Marcellinus and Peter		[companions.]
3		[the Martyr.]	St. Mary Magdalen of Pazzi.	
4			St. Francis Caracciolo.	
5		St. Boniface and his fellow-		
6		[Martyrs.]	St. Norbert.	
7				
8	St. Medard.	SS. Medardus & Gildardus.	St. William of York.	
9	SS. Primus and Felicianus.	Transl. of St. Ed. the Mart.	SS. Primus and Felicianus.	St. Cyril of Alexandria.
10	St. Barnabas.	[SS. Primus and Felician.	St. Margaret, Queen of Scots.	
11		St. Barnabas.	St. Barnabas.	SS. Bartholomew and Bar-
12		SS. Basilides, Cyrinus, and	SS. John a Facundo, Basilides, Cyri-	[nabas, Apostles.]
		[Nabor.]	[nus, Nabor, and Nazarius.]	
13			St. Anthony of Padua.	
14	St. Vitus.	St. Basil. [Crescentia.]	St. Basil.	Elisha the Prophet.
15		SS. Vitus, Modestus, and	SS. Vitus, Modestus, and Crescentia.	Amos the Prophet.
16		Translation of St. Richard.		
17	SS. Diogenes and Blastus.		SS. Mark and Marcellian.	
18	SS. Marcellian and Mark.	SS. Mark and Marcellian.	SS. Juliana, Falconeri, Gervase, and	
19	SS. Gervase and Prothase.	SS. Gervase and Prothase.	St. Silverius. [Protase.]	St. Jude, Apostle.
20		Transl. of St. Edw. K. & M.		
21			St. Aloysius Gonzaga.	
22	St. James the Apostle.	St. Alban.	SS. Alban and Paulinus.	
23		St. Etheldreda.		
24	St. John Baptist.	Nativity of St. John Bapt.	Nativity of St. John Baptist.	Nativity of St. John Bapt.
25			St. William.	
26	SS. John and Paul.	SS. John and Paul, Martyrs.	SS. John and Paul.	
27				
28	St. Leo.	St. Leo.	St. Leo.	SS. Cyrus and John.
29	SS. Peter and Paul.	SS. Peter and Paul.	SS. Peter and Paul.	SS. Peter and Paul.
30		Commemoration of St. Paul.	Commemoration of St. Paul.	

THE MINOR HOLYDAYS OF MAY (*continued*).

St. Augustine was at first buried abroad: but after the completion of the Cathedral at Canterbury his remains were translated thither, having first reposed for a while in the Church of St. Peter and St. Paul in that city. How much of the dust of our great churches is the dust of those of whom the Holy Ghost has said, "Right dear in the sight of the Lord is the death of His Saints"! [Sar. Ep. and Gosp.: Ecclus. xlvii. 8—11. St. Luke x. 1—7. During Easter-tide, St. John xv. 1—7.]

27] THE VENERABLE BEDE was born A.D. 673 at Jarrow, a village in Durham, not far from the mouth of the Tyne. About the same time the sister monasteries of St. Peter at Wearmouth, and St. Paul at Jarrow, had been founded by a great benefactor of Northern England, St. Benedict Biscop. At seven years of age, Bede was committed to the care of Ceolfrid, Abbot of Jarrow, who built a church there, of which the dedication stone at least, and possibly the whole of the chancel, still remain. Here the child made great progress in learning and piety, under various able masters; and at the unusually early age of nineteen, was ordained deacon by St. John of Beverley, then Bishop of Hexham. At thirty he was ordained priest by the same prelate. From this time he began to compose and compile books principally, but not exclusively, on theological subjects; and he had also a great school, similar to that in which he had been himself instructed. He paid great attention to the singing in the conventual church

of Jarrow. A very interesting letter from Cuthbert, one of his scholars, addressed to one Cuthwin, a monk who had been his fellow-student, gives an affecting account of the last days of their old master. He died on the Eve of the Ascension, May 26, A.D. 735, and was buried in St. Paul's Church at Jarrow. In 1020 his remains were conveyed to Durham Cathedral, and in 1155 were enclosed in a rich shrine. At the Reformation they were buried, and now rest, under a plain tomb in the Galilee, with this inscription:—

HAC SVNT IN FOSSA
BEDÆ VENERABILIS OSSA.

There is a story told about his shrine, which illustrates the wide-spread reputation possessed by Bede in the middle ages. It is that a French Bishop on his way to or from Scotland offered a very small coin at St. Cuthbert's shrine, saying, "Sancte Cuthberte, si sanctus sis, ora pro me." But on coming to Bede's shrine, he offered a French crown, saying, "Sancte Beda, quia Sanctus es, ora pro me." His writings are still day by day instructing the whole of the Western Church, and probably will ever continue to do so. The title of "Venerable" seems to have been first given him about the ninth century, and he has often been styled the English Doctor. [No Epistle or Gospel is appointed for this day in the later Salisbury Missals, if in any.]

THE MINOR HOLYDAYS OF JUNE.

1] ST. NICOMEDE is supposed to have been a disciple and fellow-labourer of St. Peter. During the persecution of Domitian he buried Felicula, a virgin martyr, with Christian rites. Thus incurring the displeasure of the heathen authorities, he himself was put to the test of being asked to sacrifice to idols. He refused to do so, and was accordingly beaten to death with whips loaded with lead, or, as some say, with a spiked club. His body was thrown into the Tiber, but was recovered by the Christians, and buried. The day of his martyrdom was Sept. 15th, and is then commemorated in the Sacramentary of St. Gregory. He is represented with the instruments of his martyrdom. [Sar. Ep. and Gosp.: Ecclus. xiv. 20, and xv. 3—6. St. Matt. xvi. 24—28. During Easter-tide, St. John xv. 1—7.]

5] ST. BONIFACE, originally named Winfrid, was of English extraction, but by his missionary labours on the Continent earned for himself the title of Apostle of Germany. He was born at Crediton, in Devonshire, about A.D. 680, and was educated in the monastery of Exeter, where also he made his profession as a monk: he afterwards studied at that of Nutcell, in the diocese of Winchester. Here he made such progress that he was appointed by the Abbot to teach others, and at thirty years of age was ordained priest. Having long had a desire to preach the Gospel to the heathen, in the year 716 he crossed over into Friesland for that purpose. Meeting with great opposition from the King, he was obliged to return, whereupon he was appointed Abbot of Nutcell, much against his will. In the course of two years he succeeded in obtaining a release, and in 719 went to Rome, and was sent by Pope Gregory II. to Germany, where he baptized great numbers of converts, and established the Church system. He also laboured with great success in Friesland, Hesse, and Saxony, after which the Pope consecrated him Bishop. Returning to his mission, he boldly cut down an oak consecrated to Jupiter, and built a chapel with the timber. He also founded many churches, and a monastery, and procured many missionaries from England. Having long laboured with great zeal and success, and obtained the titles of Archbishop and Primate of all Germany, he was martyred near Utrecht at the age of seventy-four. He is represented as an Archbishop, hewing down the oak, or with it prostrate at his feet, and sometimes with a scourge, or a book pierced through with a sword. [Sar. Ep. and Gosp.: 1 Cor. iv. 9—14. St. Matt. x. 23—26. During Easter-tide, St. John xv. 5—7.]

17] ST. ALBAN, MARTYR.—Our Calendar differs from the ancient English Calendar and the Modern Roman, which dedicate the 22nd to his memory, in placing St. Alban's day on the 17th of June. St. Alban is the first recorded British martyr, and was born at Verulam, near the present town of St. Alban's, an important Anglo-Roman city. It is thought from his name that he was born of Roman parents. It is recorded that they were of high rank, and sent him to Rome for his education. On his return he was one of the chief citizens of Verulam, and, though as yet a heathen, was known for his humane and charitable disposition. He sheltered a certain priest who was fleeing from persecution, and by his example and instructions was won over to the Christian faith. The Roman governor, hearing that he was harbouring the priest, sent soldiers to seek him, but his host had enabled him to escape and continue his work by exchanging clothes with him, and then confessed himself a Christian. Refusing to sacrifice to idols, he was first scourged, and then beheaded. On the way to martyrdom, the executioner was converted, it is said, by the miracles of the river drying up for them to pass, and a fountain springing forth. Both suffered together, and many of the spectators being converted also, were put to death, about A.D. 303. Upon the spot where they suffered, the great Benedictine Abbey, and the present town of St. Alban's, sprang up. The Abbot of St. Alban's held precedence over all the rest because of the patron being the first canonized Saint and Martyr of Britain. He is represented as a young layman, having a sword and long cross or crucifix: sometimes he bears the martyr's palm, or is in armour and coronet, with a sceptre. The priest whom he had sheltered, whose name was Amphibalus, fled into Wales, and after making many converts, at last received the crown of martyrdom himself. [Sar. Ep. and Gosp.: Wisd. iv. 7—11. 13—15. St. Matt. xvi. 24—28.]

20] It is mentioned above (March 18) that after the barbarous murder of Edward, King of the West Saxons, at Corfe Castle, his body was buried without any solemnity. Three years afterwards, however, it was translated by Elferius, Duke of Mercia, to Shaftesbury, and there solemnly interred, as being that of a king and martyr; and this event is commemorated on the 20th of June. [Sar. Ep. and Gosp.: Ecclus. xxxi. 8—11. St. Luke xiv. 26—33.]

JULY hath 31 Days.

			Morning Prayer.		Evening Prayer.		
			1 Lesson.	2 Lesson.	1 Lesson.	2 Lesson.	
1	g	Calendæ.	Prov. 11	Luke 13	Prov. 12	Phil. 1	
2	A	6. Non.	13	14	14	2	
3	b	5. Non.	15	15	16	3	
4	c	4. Non.	17	16	18	4	
5	d	3. Non.	19	17	20	Colos. 1	
6	e	Pr. Non.	21	18	22	2	
7	f	Nonæ.	23	19	24	3	
8	g	8. Id.	25	20	26	4	
9	A	7. Id.	27	21	28	1 Thess. 1	
10	b	6. Id.	29	22	31	2	
11	c	5. Id.	Eccles. 1	23	Eccles. 2	3	
12	d	4. Id.	3	24	4	4	
13	e	3. Id.	5	John 1	6	5	
14	f	Pr. Id.	7	2	8	2 Thess. 1	
15	g	Idus.	9	3	10	2	
16	A	17. Cal. Aug.	11	4	12	3	
17	b	16. Cal.	Jerem. 1	5	Jerem. 2	1 Tim. 1	
18	c	15. Cal.	3	6	4	2, 3	
19	d	14. Cal.	5	7	6	4	
20	e	13. Cal.	7	8	8	5	
21	f	12. Cal.	9	9	10	6	
22	g	11. Cal.	11	10	12	2 Tim. 1	
23	A	10. Cal.	13	11	14	2	
24	b	9. Cal.	15	12	16	3	
25	c	8. Cal.	8. James, Apostle and Martyr.	13	13	4	
26	d	7. Cal.	S. Anne, Mother to B. Virgin Mary.	17	14	18	Titus 1
27	e	6. Cal.		19	15	20	2, 3
28	f	5. Cal.		21	16	22	Philem.
29	g	4. Cal.		23	17	24	Heb. 1
30	A	3. Cal.		25	18	26	2
31	b	Pr. Cal.		27	19	28	3

Comparative View of the Calendar for JULY.

	Bede, A.D. 735.	Salisbury Use, A.D. 1514.	Modern Roman.	Eastern.
1				SS. Cosmas and Damian.
2	SS. Processus and Mar-	Visitation of B. V. Mary.	Visitation of B. V. Mary. SS. Pro-	Vestment of B. V. Mary.
3	[tinianus.]		[cessus and Martinianus.]	
4		Transl. and Ordination of		
5		[St. Martin.]		
6				
7		Transl. of St. Thomas the	Translation of St. Thomas.	
8		[Martyr.]	St. Elizabeth of Portugal.	
9				St. Pancratius.
10	The Seven Brethren.	The Seven holy Brethren.	Seven Brethren, and SS. Rufina and	
11		Transl. of St. Benedict.	St. Pius. [Secunda.]	
12			SS. John Gualbert, Nabor, and Felix.	
13			St. Anacletus.	St. Gabriel the Archangel.
14			St. Bonaventure.	St. Aquila, Apostle.
15	St. Cyricus.	Transl. of St. Swithun.	St. Swithun.	
16		Transl. of St. Osmund.	B. Virgin Mary of Mount Carmel.	
17		St. Kenelm.	St. Osmund.	St. Marina. [Margaret.]
18		St. Arnulph.	SS. Camillus de Lellis and Sympho-	
19			[rosa, and her seven sons.]	
20		St. Margaret.	St. Vincent of Paul.	St. Jude, Apostle.
21		St. Praxedes.	SS. Jerome Emilian and Margaret.	Elijah the Prophet.
22		St. Mary Magdalen.	SS. Henry, Emp., and Praxedes.	
23		St. Apollinaris.	St. Mary Magdalen.	St. Mary Magdalen the
24		St. Christina.	SS. Apollinaris and Liborius.	[Ointment-bearer.]
25	St. James, brother of John.	St. James.	SS. Alexius and Christina.	
26		St. Anne.	SS. James, Ap., and Christopher.	St. Anne.
27		The Seven Sleepers.	St. Anne, Mother of the B. V. Mary.	
28		St. Sampson.	St. Pantaleon. [Innocent.]	
29	SS. Felix, Simplex, Faus-	SS. Felix and Faustus.	SS. Nazarius, Celsus, Victor, and	SS. Prochorus, Nicanor, Ty-
30	[tinus, and Beatrice.]		SS. Martha, Felix, Simplicius, Faus-	[mon, and Parmenas, App-
31	SS. Abdon and Sennes.	SS. Abdon and Sennes.	[tinus, and Beatrice.]	SS. Silas, Silvanus, and
		St. Germanus.	St. Ignatius of Loyola.	[their companions, App-

THE MINOR HOLYDAYS OF JULY.

2] VISITATION OF THE BLESSED VIRGIN MARY.—This minor festival of the Blessed Virgin was instituted A.D. 1389, by Pope Urban VI, and confirmed at the Council of Basle, A.D. 1431, that “she being honoured with this solemnity, might reconcile her son, Who is now angry for the sins of men, by her intercession, and that she might grant peace and amity among the faithful.” The event which it commemorates is the visit of the Blessed Virgin to her cousin Elizabeth recorded in the Gospel for the day. [Sar. Ep. and Gosp.: Cant. ii. 1—4 and 10—14. St. Luke i. 39—47.]

4] TRANSLATION OF ST. MARTIN, BP. AND CONF.—This festival commemorates the translation of the relics of St. Martin from the place of his burial at Cande, in the diocese of Tours, to a basilica dedicated in his honour, immediately adjacent to the city of Tours, A.D. 473. The Sarum Calendar also commemorates his ordination. The keeping of his relics was committed to a fraternity which developed into the famous chapter of St. Martin, of which the King of France was *ex officio* head, under the title of Abbat. The Huguenots tore down the feretory, and burnt the relics, with the exception of some portions which were recovered and still exist. [Sar. Ep. and Gosp.: Ecclus. xlv. 17. 20, 21—23; xlv. 6, 7. 15, 16. St. Luke xii. 32—34.]

15] ST. SWITHUN, BP. OF WINCHESTER.—St. Swithun, or Swithin, was born in the kingdom of the West Saxons, was educated in the monastery attached to Winchester Cathedral, and was ordained priest early in the ninth century by Helmstan, Bishop of that see, whom he succeeded A.D. 838, having been consecrated by Cealnoth, Archbishop of Canterbury. He devoted himself with great zeal to the work of his diocese, and was celebrated for his humility, as well as his austerity, and works of charity. He died July 2, A.D. 862, and was buried at his own request outside the church, where men might walk over him, and the rain water his grave. In A.D. 971 the relics were translated to a rich shrine within the cathedral; but it is recorded that a most violent rain fell on the destined day, and continued for thirty-nine days, whence arose the popular notion that if it rain on St. Swithin's Day, it will for thirty-nine following. The festival is kept on the 15th in honour of this translation; and Winchester Cathedral, which before had been dedicated to St. Peter, was now dedicated also to St. Swithin. When the cathedral was rebuilt by Bishop Walkelyn, the relics were placed in a more costly shrine, A.D. 1093. More than fifty churches in England are dedicated to this saint. [Sar. Ep. and Gosp.: Heb. vii. 23—27. St. Luke xii. 35—40.]

20] ST. MARGARET, V. AND M. OF ANTIOCH.—Little is known respecting this saint except that she suffered martyrdom at Antioch in Pisidia about A.D. 278, probably in the tenth general persecution. The so-called “Acts of St. Margaret” are not at all to be depended on, though it is probable, from the great popularity of the saint, that they were generally accepted in mediæval times. In the Greek Church she is called St. Marina, and commemorated on the 17th; and it is curious that on an old bell at Pitlington, near Durham, are the words *Santa*

Marineta, as if the two forms of the name had been amalgamated. No less than 238 churches are dedicated to St. Margaret; but it is probable that some of these, especially in the North of England, may belong to St. Margaret, Queen of Scotland. She is represented with the martyr's crown and palm; sometimes she stands piercing a dragon with a long cross, or emerges from its rent body, while her robe is yet passing through its mouth. She was esteemed as the patron of women in childbirth. [Sar. Ep. and Gosp.: Ecclus. li. 9—12. St. Matt. xiii. 44—52.]

22] ST. MARY MAGDALEN.—The Western Church anciently recognized Mary Magdalen, the sister of Lazarus, and “the woman that was a sinner,” as one and the same person, while the Eastern Church has held them to be distinct. This opinion having been to a great extent received in England since the Reformation, the special office has been removed from the First Book of Edward VI., and the festival has ceased to be a “red-letter day.” In the Greek Church she is esteemed as the equal of the Apostles, as having been the first witness of the Resurrection. She is supposed to have retired to Ephesus with the Blessed Virgin and St. John, and to have been buried there. Her relics were translated to Constantinople by the Emperor Leo the Philosopher, and placed in a church dedicated to St. Lazarus, as if under the supposition that she was his sister. In Western art she is represented with long golden hair, and always having near her the alabaster box of ointment. She is often pictured as a penitent, in a cave, with a simple cross and a skull, and sometimes she is being carried by angels to heaven. The Collect in the First Book of Edward VI. was as follows:—“Merciful Father, give us grace that we never presume to sin through the example of any creature; but if it shall chance us at any time to offend Thy Divine Majesty, that then we may truly repent and lament the same, after the example of Mary Magdalen, and by a lively faith obtain remission of all our sins, through the only merits of Thy Son our Saviour Christ. Amen.” The Epistle and Gospel were from the Salisbury Missal, as here given. [Sar. Ep. and Gosp.: Prov. xxxi. 10—31. St. Luke vii. 36—50.]

26] ST. ANNE, MOTHER OF THE B. V. M.—We have no information whatever in Holy Scripture respecting the genealogy of the Blessed Virgin, except that she was of the “house and lineage of David.” But St. John Damascene extols the virtue of St. Joachim and St. Anna, speaking of them as her parents; and St. Anne is frequently represented in the catacombs at Rome, with her name in connexion with the figure. She was doubtless honoured in the Primitive Church as the parent of the Mother of God, and as such retains her place in our Calendar. The Emperor Justinian I. built a church at Constantinople in honour of St. Anne, cir. A.D. 550. In the Catacombs and in other early representations she has her hands stretched out as in prayer, and has near her a dove, with a ring or crown in its beak. In Mediæval times she is figured with a book in her hand, teaching the Blessed Virgin to read, and sometimes pointing to the words “*Radia Jesse floruit.*” [Sar. Ep. and Gosp.: Prov. xxxi. 10—31. St. Matt. i. 1—16.]

AUGUST hath 31 Days.

				Morning Prayer.		Evening Prayer.	
				1 Lesson.	2 Lesson.	1 Lesson.	2 Lesson.
1	c	Calendæ.	Lammas Day.	Jerem. 29	John 20	Jerem. 30	Heb. 4
2	d	4. Non.		31	21	32	5
3	e	3. Non.		33	Acts 1	34	6
4	f	Pr. Non.		35	2	36	7
5	g	Nonæ.		37	3	38	8
6	A	8. Id.	Transfiguration of our Lord.	39	4	40	9
7	b	7. Id.	Name of Jesus.	41	5	42	10
8	c	6. Id.		43	6	44	11
9	d	5. Id.		45, 46	7	47	12
10	e	4. Id.	S. Laurence, Archd. of Rome and M.	48	8	49	13
11	f	3. Id.		50	9	51	James 1
12	g	Pr. Id.		52	10	Lam. 1	2
13	A	Idus.		Lam. 2	11	3	3
14	b	19. Cal. Sept.		4	12	5	4
15	c	18. Cal.		Ezek. 2	13	Ezek. 3	5
16	d	17. Cal.		6	14	7	1 Pet. 1
17	e	16. Cal.		13	15	14	2
18	f	15. Cal.		18	16	33	3
19	g	14. Cal.		34	17	Dan. 1	4
20	A	13. Cal.		Dan. 2	18	3	5
21	b	12. Cal.		4	19	5	2 Pet. 1
22	c	11. Cal.		6	20	7	2
23	d	10. Cal.	Fast.	8	21	9	3
24	e	9. Cal.	S. Bartholomew, Apostle and Mart.	22	22	11	1 John 1
25	f	8. Cal.		10	23	11	2
26	g	7. Cal.		12	24	Hosea 1	3
27	A	6. Cal.		Hos. 2, 3	25	4	4
28	b	5. Cal.	S. Augustine, Bishop of Hippo, C. D.	5, 6	26	7	5
29	c	4. Cal.	Beheading of S. John Baptist.	8	27	9	2, 3 John
30	d	3. Cal.		10	28	11	Jude
31	e	Pr. Cal.		12	Matt. 1	13	Rom. 1

Comparative View of the Calendar for AUGUST.

	Bede, A.D. 735.	Salisbury Use, A.D. 1514.	Modern Roman.	Eastern.
1	The Maccabees.	St. Peter's Chains.	St. Peter's Chains, the Holy Macha- [bees.	
2	St. Stephen, Pontiff.	St. Stephen, Pope & Mart.	SS. Alphonsus Liguori and Stephen.	Translation of St. Stephen,
3		Invention of St. Stephen,	Finding of St. Stephen, Proto-mart.	[Proto-martyr.
4		[Proto-martyr.	St. Dominic. [V. M. ad Nives.	The Seven holy Children at
5		St. Oswald.	Dedication of the Church of the B.	[Ephesus.
6	SS. Xystus, Felicissimus, [and Agapetus.	Transfiguration.	Transfigr. of our Lord, SS. Xystus, [Felicissimus, and Agapitus.	Transfiguration.
7		Name of Jesus, St. Donatus.	St. Cajetan.	
8		St. Cyriacus and his fellow-	SS. Cyriacus, Largus, & Smaragdus.	
9		St. Romanus. [martyrs.	St. Romanus.	St. Matthias, Apostle.
10	St. Laurence.	St. Laurence.	St. Laurence.	St. Laurence.
11	St. Tiburtius.	St. Tiburtius.	SS. Tiburtius and Susanna.	
12		[low-martyrs.	St. Clare.	
13		St. Hippolytus and his fel-	SS. Hippolytus and Cassian.	
14		St. Eusebius.	St. Eusebius.	
15	Assumption of St. Mary.	Assumption of B. V. Mary.	Assumption of the B. V. Mary.	The "falling asleep" of [the B. V. Mary.
16			St. Hyacinth.	
17				
18	St. Agapetus.	St. Agapetus.		
19		St. Magnus.		
20			St. Bernard.	St. Thaddeus, Apostle.
21			St. Jane Francis.	Samuel the Prophet.
22	St. Timothy.		SS. Timothy, Hippolytus, and Sym-	
23		SS. Timothy & Apollinaris.	St. Philip Benitus. [phorian.	
24		St. Bartholomew.	St. Bartholomew.	St. Eutyches.
25	St. Bartholomew.		St. Louis, King.	Transl. of St. Bartholomew.
26			St. Zephyrinus.	
27		St. Rufus.	St. Joseph Calasactius.	
28	St. Augustine.	St. Augustine of Hippo.	SS. Augustin and Hermes. [bina.	
29	Passion of St. John Baptist.	Behead. of St. John Bapt.	Decollation of St. John Bapt., St. Sa-	Behead. of St. John Bapt.
30		SS. Felix and Adauctus.	SS. Rose of Lima, Felix, & Adauctus.	SS. Alexander, John, and
31		St. Cuthburga.	St. Aidan, Bishop of Lindisfarne.	[Paul the younger, Patri- [archs of Constantinople.

1] LAMMAS DAY.—The observation of this day as a feast of thanksgiving for the first-fruits of the corn dates from Saxon times, in which it was called *Hlaf-masse*, or Loaf-mass, from the offering, at the Mass, of bread made of the new corn. Other explanations, e. g. Lamb-mass, *Ad Vincula mass*, &c., have been given, but the above is certainly the true one, as appears from the Saxon Menology, &c. This is one of the four *Cross-quarter* days, at which rents were formerly due.

6] TRANSFIGURATION.—This festival was instituted in the Greek Church as early as A.D. 700, and appears to have been observed at Rome in the time of St. Leo (cir. 450). Pope Callixtus the Third issued a bull for its general observance, A.D. 1457, in remembrance of the deliverance of Belgrade from Mahomet the Second. The glorious mystery of the Transfiguration is related by the three former Evangelists; but the festival has never ranked with the other festivals of our Lord, probably because its theological significance, though great, has appeared to be less evident than that of the rest. [Sar. Ep. and Gosp.: 2 St. Pet. i. 16—19. St. Matt. xvii. 1—9.]

7] NAME OF JESUS.—This commemoration was removed at the Reformation from the Second Sunday after the Epiphany, but in Saxon times it was observed on the Feast of the Circumcision. The special point which it sets before us is the peculiar sanctity of that Name at which every knee should bow, and in the power of which countless miracles have been wrought; a sanctity in some respects analogous to that of the Sacred name Jehovah, but representing to us the Love of the Saviour as well as the Majesty of His Godhead. The acknowledged symbol of this name in our Church for many centuries has been *ih̄s* or *ih̄s*; Anglicized forms of I.H.C., the first three letters in the Greek form of the name IHCOYC. But I.H.S. is a modern alteration originating with the Jesuits, whose symbol it is, and representing "Jesus Hominum Salvator." [Sar. Ep. and Gosp.: Acts iv. 8—12. St. Matt. i. 20—23.]

10] ST. LAURENCE, the Deacon and Martyr, is said to have been of Spanish extraction, but nothing is certainly known respecting his early years. He was ordained Deacon by St. Sixtus II., and soon afterwards appointed chief of the Seven Deacons of Rome. The Christians were at this time suffering under the eighth general persecution, and the Bishop of Rome was led forth to martyrdom in A.D. 258. Laurence, the Deacon, made a most affecting appeal to be allowed to suffer with his "father," whom he had so often assisted in offering the Holy Sacrifice. This did not come to pass; but within a week he drew upon himself the fury of the persecutors by refusing to deliver up the property of the Church, and showing instead the poor Christians as the real treasures of Christ. He was instantly seized, and put to the torture, but could not be compelled to deny Christ. He was then laid on an iron frame with bars like a gridiron, and slowly burnt to death over live coals. He suffered with marvellous patience and tranquillity, praying for the conversion of Rome. Prudentius, in a beautiful hymn, ascribes the final conversion of the city to this martyr's intercession. He is named in the earliest Roman Calendar, A.D. 354, and his name has always been in the Canon of the Roman mass. No less than 250 churches are dedicated to him in England, and he was honoured by a vigil and octave in this country as well as at Rome. He is one of the three "Minor" Saints in the Calendar of Queen Elizabeth's reign. His distinguishing emblem is the gridiron, and he is represented as a young man in alb and dalmatic, carrying a clasped book, or a bag, the latter in allusion to the treasure he refused to deliver up. The Palace of the Escorial, about fifteen miles from Madrid, was built by Philip the Second, A.D. 1563, in place of a monastery dedicated to St. Laurence which he had been obliged to demolish in some military operations. It is built on the plan of a gridiron, which form is also carried into all the details. [Sar. Ep. and Gosp.: 2 Cor. ix. 6—10. St. John xii. 24—26.]

28] ST. AUGUSTINE, or Austin, was one of the most illustrious of the Fathers, and is honoured as one of the Four Doctors of the Western Church. He was born, of a good family, A.D. 354, at Togaste, in Numidia. His mother Monica was a Christian; his

father Patricius, a Pagan. Both paid great attention to the education of their son, the mother to his spiritual training, the father to that secular education which was the foundation of his subsequent fame as a scholar. After being taught at home for a while, he was sent to Madaura to be perfected in grammar and rhetoric. Returning home at the age of fifteen, he spent a year in idleness, and, to the great sorrow of his holy mother, acquired dissolute habits. After this he was sent to complete his education at Carthage, and here he plunged still deeper into vice and dissipation. He did, however, devote some portion of his time to study, and began to read the Holy Scriptures, which, of course, he could not at this period of his life appreciate. He then fell into the Manichean heresy, which appears to have accorded but too well with his pride of intellect and profligacy of life. St. Monica was deeply grieved at the errors of her son, and would not even eat with him; but being assured by a holy Bishop that the son of so many prayers and tears could not be lost, she became reconciled to him again. About this time he began to distrust Manichæism, and took to scepticism. Being rhetoric professor at Milan in A.D. 384, he was attracted by the Sermons of St. Ambrose, through whose influence he was gradually converted to the Catholic faith, and was baptized A.D. 387. The *Te Deum* is sometimes called the Hymn of St. Ambrose and St. Augustine, from a tradition that it was composed and sung by them on this occasion. [See p. 10.] After a diligent study of St. Paul's Epistles and of theology generally under the direction of St. Ambrose, he returned to Togaste, where he formed a small society of brethren who devoted themselves to a religious life. In A.D. 391 he was admitted to Holy Orders by Valerius, Bishop of Hippo, whose coadjutor in the episcopate he became in 395, having spent the previous four years in retirement. He began to write against the Donatists in 394. In 396 he succeeded Valerius, and was obliged to occupy the Bishop's residence, but here he also established a community of clergy living by rule, which afterwards developed into the Order of Augustinian Canons. After an episcopate of thirty-five years he lived to see Hippo besieged by the Vandals. Augustine and his clergy earnestly prayed for deliverance from the Church's foes; but in the third month of the siege he died of a fever, on August 28th, A.D. 430, in his seventy-seventh year, and was buried in the Church of St. Stephen. He had been summoned to the third general council, but the Emperor's messenger arrived just too late to find him alive. Nearly fifty years afterwards the African Bishops carried the body with them to Sardinia, whither they were banished by Huneric, and about A.D. 710 it was purchased from the Saracens by the Lombards, and solemnly translated to the Church of St. Peter at Pavia, where it now rests. His festival was observed at Carthage, a century after his death, and is a holyday of obligation in the Spanish dominions. The distinguishing emblem of St. Augustine is a child with a shell, in allusion to his vision of the Infant Jesus pouring water into a hole in the sand of the shore, to show him the impossibility of understanding the mystery of the Trinity. Sometimes a heart, or an eagle, are represented with him. [Sar. Ep. and Gosp.: Ecclus. xlvii. 8—11. St. Matt. v. 13—19.]

29] This minor festival of ST. JOHN the Baptist commemorates his being beheaded at the instigation of Herodias, as related in Matt. xiv. 1—12. It is probable that the event took place shortly before the Passover, A.D. 32; and that it is celebrated on the 29th of August as the day on which some translation of his relics took place. Portions of his head are said to be still kept at Amiens and at Rome. He was held in great honour in this country, upwards of 390 churches being dedicated to him, and his decollation, and the circumstances connected with it, were favourite subjects in mediæval representations. The nativity of St. John the Baptist (June 24th) is observed as his greater festival, probably because of his miraculous birth, and its connexion with that of our Blessed Lord. The *Agnus Dei* is his distinguishing emblem, and he is represented clad in skins, carrying a vexillum or pennon with the words *Ecce, agnus Dei*. [Prov. x. 28—32, and xi. 3. 6. 8—11. St. Mark vi. 17—29.]

SEPTEMBER hath 30 Days.

				Morning Prayer.		Evening Prayer.	
				1 Lesson.	2 Lesson.	1 Lesson.	2 Lesson.
1	f	Calendæ.	Giles, Abbot and Confessor.	Hos. 14	Matt. 2	Joel 1	Rom. 2
2	g	4. Non.		Joel 2		3	3
3	A	3. Non.		Amos 1		Amos 3	4
4	b	Pr. Non.		3		4	5
5	c	Nonæ.		5		6	6
6	d	8. Id.		7		8	7
7	e	7. Id.	Eunuchus, Bishop of Orleans.	9		Obadiah.	8
8	f	6. Id.	Nativity of the Blessed Virgin Mary.	Jonah 1	9	John 2, 3	9
9	g	5. Id.		4	10	Micah 1	10
10	A	4. Id.		Micah 2	11	3	11
11	b	3. Id.		4	12	5	12
12	c	Pr. Id.		6	13	7	13
13	d	Idus.		Nah. 1	14	Nah. 2	14
14	e	18. Cal. Oct.	Holy Cross Day.	3	15	Hab. 1	15
15	f	17. Cal.		Hab. 2	16	3	16
16	g	16. Cal.		Zeph. 1	17	Zeph. 2	1 Cor. 1
17	A	15. Cal.	Lambert, Bishop and Martyr.	3	18	Hag. 1	2
18	b	14. Cal.		Hag. 2	19	Zech. 1	3
19	c	13. Cal.		Zech. 2, 3	20	4, 5	4
20	d	12. Cal.		6	21	7	5
21	e	11. Cal.	Fast. S. Matthew, Ap., Eba., and Mart.		22		6
22	f	10. Cal.		8	23	9	7
23	g	9. Cal.		10	24	11	8
24	A	8. Cal.		12	25	13	9
25	b	7. Cal.		14	26	Mal. 1	10
26	c	6. Cal.	S. Cyprian, Archb. of Carthage and M.	Mal. 2	27	3	11
27	d	5. Cal.		4	28	Tobit 1	12
28	e	4. Cal.		Tobit 2	Mark 1	3	13
29	f	3. Cal.	S. Michael, and all Angels.		*2		*14
30	g	Pr. Cal.	S. Jerome, Pr. Conf. and Doct.	4	3	6	15

* There are proper Second Lessons for both Morning and Evening Prayer, and the ordinary ones were doubtless left in by mistake.

Comparative View of the Calendar for SEPTEMBER.

	Bede, A.D. 735.	Salisbury Use, A.D. 1514.	Modern Roman.	Eastern.
1		St. Giles.	SS. Raymond Nonnatus, Giles, and [the Twelve Brethren.	New Year's Day. Joshua.
2			St. Stephen, King.	
3				
4		Transl. of St. Cuthbert.		Moses the Prophet.
5		St. Bertinus.	St. Laurence Justinian.	Zacharias, Father of St. [John Baptist.
6				
7				
8	Nativity of St. Mary.	Nativity of B. V. Mary.	Nativity of B. V. Mary. St. Adrian.	Nativity of B. V. Mary.
9		St. Gorgonius.	St. Gorgonius.	SS. Joachim and Anna.
10			St. Nicolas of Tolentinum.	
11	SS. Prothus and Jacinthus.	SS. Prothus and Jacinthus.	SS. Protus and Hyacinth.	
12				
13				
14	SS. Cornelius and Cyprian.	Holy Cross Day. SS. Cor- [nelius and Cyprian.	Exaltation of the Holy Cross. St. Nicomedes.	Exaltation of the Holy [Cross.
15		St. Edith.	SS. Cornelius and Cyprian, Euphemia, [Lucy and Geminianus.	St. Euphemia.
16				
17		St. Lambert.	Impression of the S. wounds of St. St. Joseph of Cupertino. [Francis.	
18			St. Januarius and his Companions.	
19			St. Eustachius and his Companions.	
20			St. Matthew.	St. Quadratus, Apostle.
21	St. Matthew.	SS. Matthew and Laudus.	SS. Thomas of Villanova, Maurice [and his Companions.	
22	St. Maurice and his fellow- [Martyrs.	St. Maurice and his fellow- [Martyrs.		
23		St. Thecla.	SS. Linus and Thecla. Blessed Virgin Mary of Mercy.	Conception of St. John B. St. Thecla.
24	Conception of St. John B.			
25		St. Firmin.		
26		St. Cyprian.	SS. Cyprian and Justina.	
27	SS. Cosmas and Damian.	SS. Cosmas and Damian.	SS. Cosmas and Damian.	
28			St. Wenceslaus.	
29	St. Michael.	St. Michael.	St. Michael.	
30	St. Jerome.	St. Jerome.	St. Jerome.	

1] The accounts of the life of St. GILES, or Ægidius, are rather confused, on account of there having been an Abbot of Arles of the same name in the preceding century. The saint commemorated on this day was born at Athens, about the middle of the seventh century, and was of noble parentage. When a young man he sold all that he had, and retired into a forest in the diocese of Nismes, where he lived in seclusion with one companion named Veredemus. Here they lived on such food as the forest afforded, and were nourished also by the milk of a tame hind. The creature having been scented by the King's dogs, was driven to her masters for protection, and thus the King discovered St. Giles in his retreat. Here he gave him land for a monastery of Benedictine monks, where he ruled as abbot for upwards of fifty years, and the spot was called Vallis Flaviana, from the name of its founder, Flavius Wamba. In A.D. 720 he had to take refuge from the Saracens at Orleans. He was, however, enabled to return to his abbey, where he died, A.D. 725. From his being said to have refused to be cured of a lameness, he is esteemed as the patron of cripples, and the churches dedicated to him, which are numerous both in this country and on the Continent, have generally been in the suburbs of cities, in order to afford poor and lame travellers a ready opportunity of resorting to them, on their entering from the country. [Sar. Ep. and Gosp.: Ecclus. xxxix. 5—9. St. Luke xi. 33—36.]

7] St. EVERTIUS, or Evortius, Bishop of Orleans, was famous in the ancient Western Martyrologies, and hence probably has found a place in our Calendar. There are various stories relating to him, but no important information of a reliable nature, farther than that he flourished about the middle of the fourth century. He is said to have been pointed out as a fit person for the office of a bishop by a dove alighting on his head; but the story is told of others, and is plainly symbolical of his designation for that office by the Holy Ghost.

8] The institution of the Feast of the NATIVITY OF THE BLESSED VIRGIN has been ascribed to Pope Sergius, cir. A.D. 695, and was universally celebrated in Mediæval times, with octave and vigil. We have no other particulars respecting the parentage of the Blessed Virgin, than that she was "of the house and lineage" of David. Tradition names her father Joachim, and her mother St. Anne (see July 26). [Sar. Ep. and Gosp.: Ecclus. xxiv. 17—22, and Wisd. iv. 1—7. Alternate days during the Octave, St. Matt. i. 1—16. The Octave, St. Luke xi. 27, 28.]

14] HOLY CROSS DAY.—This is also called the Feast of the Exaltation of the Holy Cross; and though it is not in Bede's Calendar, it, as well as the 3rd of May, was called "Roodmas-day" by our Saxon ancestors. It is kept in honour of the public exposition of a portion of the Cross, in the basilica erected at Jerusalem by the Empress Helena (see May 3). This church was solemnly consecrated on Sept. 13, A.D. 335, and on the next day, being Sunday, the precious relic was exposed from a lofty place within the building. The custom was continued annually, and so the festival has been observed on this day ever since, both in the East and in the West. This festival also commemorates that famous appearance of the "sign of the Son of Man in the heavens" which is said to have decided the conversion of the Emperor Constantine; and another event connected with it is the recovery by Heraclius (A.D. 629) of that portion of the Cross which had been carried away from Jerusalem by Chosroes, King of the Persians, A.D. 614. There are no less than 106 churches in England under the designation either of Holy Rood or of St. Cross.

The Ember Days in September are the Wednesday, Friday, and Saturday after Holy Cross Day. [Sar. Ep. and Gosp.: Gal. v. 10—12, and vi. 12—14. St. John xii. 31—36.]

17] St. LAMBERT, or Landebert, was born of Christian parents of rank and wealth, at Maestricht, where, after a careful education, he was committed to the care of St. Theodard, the Bishop, at whose death he succeeded to the see. When Childeric, King of France, was dethroned and murdered, in A.D. 673, Lambert, who was known to be his friend, was driven into exile. Being afterwards restored, he laboured much for the conversion of the heathen. In the fortieth year of his episcopate he was murdered, on the 17th of September, A.D. 709, having incurred the

anger of the King's officer, Pepin, Lord of Herstal, by boldly rebuking vice; and thus he came to be considered a martyr. Through the translation of his relics thither, the village of Liège became a city; but the Cathedral of St. Lambert was destroyed at the Revolution. [Sar. Ep. and Gosp.: Heb. v. 1—6. St. Matt. ix. 35—38, and x. 7, 8, 16.]

26] St. CYPRIAN, ARCHBISHOP OF CARTHAGE, AND MARTYR.—This festival was originally kept, together with that of St. Cornelius, Bishop of Rome, on the 14th of September, but on account of Holy Cross Day, was transferred to the 16th, on which day the Eastern and Roman Churches still keep it, as did the Mediæval English Church. In the Sarum and Roman Calendars the 26th was devoted to another St. Cyprian, a converted magician of Antioch. The famous St. Cyprian, of Carthage, was born in that city to the rank of a senator, and for many years he was celebrated for his eloquence, and as a teacher of rhetoric. When past middle age he was converted, and having been prepared for baptism by a priest named Cæcilius, he took from him his Christian name. Being ordained priest, he soon after this succeeded Donatus in the see of Carthage, A.D. 248. He is described as having been a model of what a bishop ought to be. But the Decian persecution soon disturbed the Church, and the decree reached Carthage, A.D. 250. The heathen furiously raged together, crying, "*Cyprianus ad leones; Cyprianus ad bestias,*" and also calling him *Coprianus* in contempt, thus fulfilling literally the words of St. Paul (1 Cor. iv. 13). He used the liberty which our Lord had given (St. Matt. x. 23) to flee from persecution for the sake of his flock, and after the death of the tyrant was enabled to return. Great difficulty was now felt respecting the restoration of those who had lapsed, and St. Cyprian assembled a synod, at which a wise and moderate conclusion was arrived at. About A.D. 255 arose that famous controversy with St. Stephen, Bishop of Rome, on the subject of heretical baptism, which shows so conclusively that the African Church did not consider that the word of the Bishops of Rome at once settled any such matter. St. Cyprian held, contrary to the opinion which has generally prevailed since, that such baptism, even if administered with the right words and the right matter, was invalid. He was at last beheaded by the Emperor Galerius, Sept. 14, A.D. 258. His works have great value. [Sar. Ep. and Gosp.: Wisd. v. 15—19. St. Matt. x. 23—25.]

30] St. JEROME, PRIEST, CONFESSOR, AND DOCTOR.—This celebrated Father was born at Stridonium (now Sâgrini), in Italy, near Aquileia, about A.D. 342. He was educated in his native town for some years, and then was sent to Rome to study under Donatus and Victorinus, two famous grammarians. Here he made great progress, being stimulated by the feeling that the Christians were despised as too illiterate to worthily explain their tenets. He then travelled through Thrace and the provinces of Asia Minor, after which, in disgust at the half-pagan manners of the Christians, he retired, at the age of thirty-one, to a desert in Syria, where he led a very austere and studious life. Here he studied Hebrew with a converted Jew; and after visiting Jerusalem and Bethlehem was ordained priest at Antioch, A.D. 378. After this he led a very wandering life, studying at all the great seats of learning, and living in constant mortification. The latter part of his life was mainly occupied in writing against heretics. He peacefully departed, Sept. 30, A.D. 420, and was buried in a monastery he had founded at Bethlehem, whence his body was afterwards translated to the Church of St. Maria Maggiore at Rome. His greatest work was the translation of the Scriptures into Latin, and he was well fitted for it by his knowledge of Eastern languages, localities, manners, and customs. This formed the basis of the Latin Vulgate, from which were taken most of the portions of Scripture used in the Western Offices, and which has been universally received in the Latin Church.

St. Jerome is represented as an old man engaged in study, with a skull near him. He has generally a lion by his side, and wears or has near him a broad hat, having cords ending in plain tassels, similar to that of a cardinal, but the cords of the latter end in a sort of network terminating in tassels. [Sar. Ep. and Gosp.: Ecclus. xlvii. 8—11. St. Matt. v. 13—19.]

OCTOBER hath 31 Days.

				Morning Prayer.		Evening Prayer.	
				1 Lesson.	2 Lesson.	1 Lesson.	2 Lesson.
1	A	Calendæ.	Remigius, Bishop of Rhemes.	Tobit 7	Mark 4	Tobit 8	1 Cor. 16
2	b	6. Non.		9	5	10	2 Cor. 1
3	c	5. Non.		11	6	12	2
4	d	4. Non.		13	7	14	3
5	e	3. Non.		Judith 1	8	Judith 2	4
6	f	Pr. Non.	Faith, Virgin and Martyr.	3	9	4	5
7	g	Nonæ.		5	10	6	6
8	A	8. Id.		7	11	8	7
9	b	7. Id.	S. Denys, Areop. B. and M.	9	12	10	8
10	c	6. Id.		11	13	12	9
11	d	5. Id.		13	14	14	10
12	e	4. Id.		15	15	16	11
13	f	3. Id.	Translation of King Edward Confessor.	Wisd. 1	16	Wisd. 2	12
14	g	Pr. Id.		3	Lu. 1 to 39	4	13
15	A	Idus.		5	1 39	6	Galat. 1
16	b	17. Cal. Nov.		7	2	8	2
17	c	16. Cal.	Etheldreda, Virg.	9	3	10	3
18	d	15. Cal.	S. Luke, Evangelist.		4		4
19	e	14. Cal.		11	5	12	5
20	f	13. Cal.		13	6	14	6
21	g	12. Cal.		15	7	16	Ephes. 1
22	A	11. Cal.		17	8	18	2
23	b	10. Cal.		19	9	Ecclus. 1	3
24	c	9. Cal.		Ecclus. 2	10	3	4
25	d	8. Cal.	Crispin, Martyr.	4	11	5	5
26	e	7. Cal.		6	12	7	6
27	f	6. Cal.		8	13	9	Phil. 1
28	g	5. Cal.	S. Simon & S. Jude, Ap. & Mart.		14		2
29	A	4. Cal.		10	15	11	3
30	b	3. Cal.		12	16	13	4
31	c	Pr. Cal.		Fast. 14	17	15	Colos. 1

Comparative View of the Calendar for OCTOBER.

	Bede, A.D. 785.	Salisbury Use, A.D. 1514.	Modern Roman.	Eastern.
1	St. Remedius.	SS. Remigius and Melorus.	St. Remigius.	St. Ananias, Apostle.
2		SS. Thomas of Hereford	The Guardian Angels.	SS. Cyprian and Justina.
3	"Passio duorum Heued-	[and Leger.	St. Thomas, Bishop of Hereford.	St. Dionysius the Areopa-
4	[dorum."		St. Francis of Assisium.	[gite.
5			SS. Placidus and Companions.	
6		St. Faith.	St. Bruno.	St. Thomas, Apostle.
7		SS. Marcus and Marcellian.	SS. Mark, Sergius, Bacchus, Mar-	
		[Martyrs.	cellus, and Apuleius.	
8		St. Dionysius and his fellow-	St. Bridget.	
9	SS. Marcellinus and Genuus.	St. Geron & his fellow-Mart.	SS. Dionysius, Rusticus, and Elen-	St. James, son of Alphæus.
10	St. Paulinus.	St. Nichasius and his fellow-	St. Paulinus.	[therius.
11		[Martyrs.	St. Francis Borgia.	St. Philip the Deacon.
12		Transl. of St. Edward Conf.	St. Wilfrid.	
13		St. Calixtus.	St. Edward, King.	
14		St. Wulfstan.	St. Callistus.	
15		St. Michael of the Mount.	St. Teresa.	St. Lucian of Antioch.
16		St. Etheldreda.	St. Hedwiges.	St. Longinus the Centurion.
17	St. Luke.	St. Luke.	St. Luke, Evangelist.	Hosea the Prophet.
18		St. Frideswide.	St. Peter of Alcantara.	St. Luke, Apostle and Ev.
19				Joel the Prophet.
20				
21		The 11,000 Virgins.	SS. Ursula and Companions, and	
			[Hilarion.	
22			St. John Cantius.	
23		St. Romanus.	Feast of our Most Holy Redeemer.	St. James, Apostle and
24			St. Raphael, Archangel.	[brother of God.
25		SS. Crispin and Crispinian.	SS. John of Beverley, Chrysanthus,	
26			St. Evaristus.	[and Daria.
27				
28	SS. Simon and Jude.	SS. Simon and Jude.	SS. Simon and Jude.	The Patriarch Abraham.
29			Venerable Bede.	[banus, &c.
30				SS. Stachys, Amplias, Ur-
31		St. Quintin.		

1] **ST. REMIGIUS, BISHOP OF RHEIMS.**—This saint, often called St. Remi, the "Apostle of France," was born about A.D. 439, of noble parents, long after their other children, his birth having been foretold by a hermit named Montanus. He received an education suitable to his station, and was always remarkable for the holiness of his life. So celebrated was he for his spiritual and other qualifications, that he was made Bishop of Rheims in the twenty-second year of his age, and was afterwards made Primate of Gaul, since which time Rheims has been the Metropolitan See of France. He is most known as having been instrumental in the conversion of King Clovis, from whom the subsequent French kings appear to have derived the titles of "Eldest Son of the Church," and "Most Christian King." The *ampulla* with which St. Remi anointed Clovis at his baptism is still preserved at Rheims, and has generally been used at the coronations of the French kings. He died in the ninety-sixth year of his age; and seventy-third of his episcopate, and was buried in the Church of St. Christopher at Rheims. His body was translated to the Benedictine Abbey, Oct. 1st, 1049, since which, Oct. 1st has been his festival instead of Jan. 13th, the day of his death. His distinguishing emblem is a dove bearing the *ampulla*. [Sar. Ep. and Gosp.: Heb. vii. 23—27. St. Luke xii. 35—40.]

6] **ST. FAITH, V. AND M.**—This Virgin Martyr, also called Fides, suffered under Datian, the Roman Prefect of Gaul, in the latter part of the third century. She was born of Christian parents, and while still very young was brought to her trial. Refusing to sacrifice to Diana, she boldly confessed Christ, notwithstanding the most horrible tortures; endeavouring, as she said, to support in reality what her name signified. She was at last beheaded, having been previously beaten with rods, and bound with chains to a brazen bed, under which fire was placed; when several of the spectators, rebuking the tyrant, and following her example in refusing to sacrifice, suffered with her. St. Vincent (see Jan. 22) endured many tortures under this same Datian, who appears to have been one of the greatest monsters of cruelty that the ages of persecution ever produced. St. Faith is represented with the instruments of her martyrdom, and wears the crown of victory. Sixteen churches, including that under the choir of St. Paul's Cathedral, which is now used only for burials, are dedicated to her. [Sar. Ep. and Gosp.: Eccus. li. 9—12. St. Matt. xiii. 44—52.]

9] **ST. DENYS ABBOP., B. AND M.**—It would seem that in the Roman and Sarum Missals this saint has been confounded with the Patron of France, for the "companions" of this later St. Denys are mentioned together with him in the Calendar, Collect, &c., while the Epistle is from the Acts of the Apostles, and relates to the conversion of "Dionysius the Areopagite," the "woman named Damaris, and others with them;" an inconsistency which remains to this day in the Roman Offices. St. Denys, or Dionysius, was a member of the Upper Council of Athens, which held its sittings on "Mars' Hill," and was converted by the preaching of St. Paul when the Apostle was brought before that Court. Eusebius mentions him as having been first Bishop of Athens, where also he is related to have suffered martyrdom under Domitian, cir. A.D. 96. The celebrated treatise on the Heavenly Hierarchies, ascribed to him, is generally considered to be spurious. In the Greek Church he is commemorated on the third of the month. This saint has no distinguishing emblem, but his namesake of France bears a mitred head in his hands, symbolizing his death by decapitation. [Sar. Ep. and Gosp.: Acts xvii. 16—34. St. Luke vi. 17—23.]

13] **TRANSL. OF KING EDWARD CONF.**—St. Edward the Confessor is pre-eminently our national saint. He was born in Oxfordshire, and succeeded his father, King Ethelred, A.D. 1041. Having suffered much at the hands of the Danes, he had in his youth vowed to make a pilgrimage to Rome, and wished to fulfil his intention as soon as he became King. But such was the danger attending his absence from England, that Leo IX. dispensed with the performance of the vow on condition that he would give to the poor the money the pilgrimage would have cost him, and found or re-found a monastery in honour of St. Peter.

This led to the re-establishment of the then ancient Abbey of Westminster on a new and magnificent footing. The buildings were completed and solemnly dedicated to St. Peter on the Feast of the Holy Innocents, A.D. 1065, and considerable portions of them remain to this day. The King was unable, through sickness, to be present at the dedication, and only just lived to know that the work was accomplished, for he died January 5th, A.D. 1066, and was buried in the new Abbey Church before the high altar, a great concourse of nobles and ecclesiastics attending. His tomb was adorned with silver and gold by William the Conqueror, and enclosed in a shrine. The body was removed by St. Thomas of Canterbury to a richer shrine, Oct. 13th, A.D. 1163, and after the rebuilding of the church by Henry III., that monarch had a most sumptuous shrine erected, the wreck of which still remains, with a superstructure of wood in the debased style of the sixteenth century. The former translation, which was probably connected with the canonization of the saint, is the one commemorated. The touching for the King's Evil dates from St. Edward, and was last performed by Queen Anne, in whose reign a special Office was used. The same power was claimed by the Kings of France for many ages. A ring given by St. Edward in his last illness to the Abbot of Westminster was long preserved as a relic, and applied to the cure of nervous diseases. Succeeding kings used to bless rings on Good Friday for the same purpose, and these were called "cramp rings." St. Edward the Confessor is distinguished by holding the ring (often disproportionately large) in his hand. The arms attributed to him are, *Az.* a cross patonce between five martlets, *Or*; but these belong to a much later period. [Sar. Ep. and Gosp.: Eccus. xxxix. 5—9. St. Luke xi. 33—36.]

17] **ST. ETHELDREDA, VIRGIN QUEEN.**—St. Etheldreda was born in Suffolk, in the seventh century, and was the daughter of Anna, King of the East Angles, whose queen was a sister of St. Hilda, Abbess of Whitby. Having been religiously brought up, she was married to the Prince of the Girvii. Being left a widow, she retired to Ely, where she led a solitary and mortified life. In A.D. 660 she was married to Egfrid, a Northumbrian prince, with whom she lived as a sister rather than a wife for twelve years. On his succeeding to the throne she retired to a monastery, from which the King attempted to withdraw her, whereupon she fled to her old retreat at Ely. Here she founded a convent, over which she presided as abbess for some years, and at last died during a pestilence, June 23rd, A.D. 679. She was succeeded by her sister, St. Sexburga, who translated her remains, and placed them in a coffin of white marble, Oct. 17th, A.D. 695. Her history is represented in sculptures under the lantern of Ely Cathedral, which arose out of the monastery founded by her. She is represented as an abbess with pastoral staff, a celestial crown on her head, and the insignia of earthly royalty lying behind her. [Sar. Ep. and Gosp.: 2 Cor. x. 17—xi. 2. St. Matt. xxv. 1—13.]

25] **ST. CRISPIN, MARTYR.**—In the ancient Calendar, St. Crispin was commemorated together with his twin brother Crispinian. They were famous in France owing to their having been among the companions of St. Denys, together with St. Quintin and others who came as missionaries from Rome into Gaul in the third century. Fixing their abode at Soissons, they preached and instructed the people by day, and when not so engaged, exercised the trade of shoe-making for a maintenance, supplying the poor free of charge. Hence they have been considered the tutelary saints or patrons of that craft, and of two famous societies in France, called *Frères Cordonniers*. The two brothers were beheaded Oct. 25th, A.D. 288, after severe tortures, under Rictius Varus, the Roman Governor of Soissons, during the progress of the Emperor Maximian through Gaul. In the sixth century a church was built and dedicated to them at Soissons, their probable place of interment, though there is a curious tradition in Kent that they were buried at Stones End, in that county. Their emblems are the martyr's palm and the shoemaker's awl, or knife. There is an interesting reference to the "Feast of Crispian" in Shakespeare (Henry V., Act iv, Sc. iii.), in connexion with the great battle of Agincourt. [Sar. Ep. and Gosp.: 1 Cor. iv. 9—14. St. Matt. x. 16—22.]

NOVEMBER hath 30 Days.

			Morning Prayer.		Evening Prayer.	
			1 Lesson.	2 Lesson.	1 Lesson.	2 Lesson.
1	d	Calendæ.	All Saints' Day.			
2	e	4. Non.	Ecclus. 16	Luke 18	Ecclus. 17	Colos. 2
3	f	3. Non.	18	19	19	3
4	g	Pr. Non.	20	20	21	4
5	A	Nonæ.	22	21	23	1 Thess. 1
6	b	3. Id.	24	22	^a 25	2
7	c	7. Id.	27	23	23	3
8	d	6. Id.	29	24	^b 30	4
9	e	5. Id.	31	John 1	32	5
10	f	4. Id.	33	2	34	2 Thess. 1
11	g	3. Id.	35	3	36	2
12	A	Pr. Id.	37	4	38	3
13	b	Idus.	39	5	40	1 Tim. 1
14	c	18. Cal. Dec.	41	6	42	2, 3
15	d	17. Cal.	43	7	44	4
16	e	16. Cal.	45	8	^c 46	5
17	f	15. Cal.	47	9	48	6
18	g	14. Cal.	49	10	50	2 Tim. 1
19	A	13. Cal.	51	11	Baruch 1	2
20	b	12. Cal.	Baruch 2	12	3	3
21	c	11. Cal.	4	13	5	4
22	d	10. Cal.	6	14	Hist. of Susan.	Titus 1
23	e	9. Cal.	S. Clement, I. Bp. of Rome and Mart.	Bell & ye Drag. 15	Isa. 1	2, 3
24	f	8. Cal.	Katharine, Virgin and Martyr.	Isa. 2	3	Philem.
25	g	7. Cal.		4	5	Heb. 1
26	A	6. Cal.		6	7	2
27	b	5. Cal.		8	9	3
28	c	4. Cal.		10	20	4
29	d	3. Cal.	Fast.	12	21	5
30	e	Pr. Cal.	S. Andrew, Apost. and Mart.	Acts 1	13	6

Note, that ^a Ecclus. 25 is to be read only to Verse 13. And ^b Ecclus. 30, only to Verse 18. And ^c Ecclus. 46, only to Verse 20.

Comparative View of the Calendar for NOVEMBER.

	Bede, A.D. 785.	Salisbury Use, A.D. 1514.	Modern Roman.	Eastern.
1		All Saints.	All Saints.	SS. Cosmas and Damian.
2		Commemoration of the de-	Commemoration of the departed.	
3		St. Winifred. [parted.	St. Winifred.	
4			SS. Charles Borromeo, Vitalis, and	
5			[Agricola.	
6		St. Leonard.		
7	The four Crowned Saints.	The four Crowned Martyrs.	The four Crowned Martyrs.	SS. Michael and all Angels.
8		St. Theodore.	Dedication of our Saviour's Church.	St. Onesiphorus.
9			SS. Andrew Avellius, Tryphon, Re-	SS. Olympas, Rhodion, So-
10			[spicius, and Nympha.	[sipater, &c.
11	St. Martin.	SS. Martin and Menna.	SS. Martin and Mennas.	
12			St. Martin, Bishop and Martyr.	
13		St. Britius.	St. Didacus.	St. John Chrysostom.
14		Transl. of St. Erkenwald.	St. Erconwald, Bishop of London.	St. Philip, Apostle.
15		St. Machutus.	St. Gertrude.	
16		St. Edmund, Archbishop.	St. Edmund, Archbishop.	St. Matthew, Ap. & Evang.
17		St. Hugh.	St. Hugh.	St. Gregory Thaumaturgus.
18			Dedication of Churches of SS. Peter	
19			[and Paul.	
20		St. Edmund, K. and Mart.	SS. Elizabeth and Pontianus.	Obadiah the Prophet.
21			St. Edmund, King and Martyr.	
22	St. Cecilia.	St. Cecilia.	Presentation of Blessed Virgin Mary.	Presentation of B. V. Mary.
23	St. Clement.	St. Clement.	St. Cecilia.	SS. Philemon and Cécilia.
24	St. Crisogonus.	St. Crisogonus.	St. Clement.	
25		St. Katharine.	SS. John of the Cross, and Chryso-	SS. Clement of Rome and
26		St. Linus.	St. Catharine. [gonus.	[Peter of Alexandria.
27			St. Felix Valois.	
28			St. Gregory Thaumaturgus.	
29	St. Saturninus.	SS. Saturninus & Sisinnius.	St. Saturninus.	
30	St. Andrew.	St. Andrew.	St. Andrew.	St. Andrew.

6] **ST. LEONARD, DEACON AND CONFESSOR.**—This saint was in his youth a nobleman of high station in the court of Clovis I., King of France. Being converted by St. Remigius, he resolved to embrace the religious life, notwithstanding the earnest importunity of the King. After remaining some time in the monastery of Micy, near Orleans, he retreated to a hermitage in a forest near Limoges, converting many as he went along. He was not allowed to remain here in solitude; for many hearing of his fame flocked to him, and eventually a monastery arose on the spot, over which he presided, and which was endowed by the King with a great part of the surrounding forest. He always took a great interest in prisoners and captives; and it is said that King Clovis granted him the privilege of releasing all whom he deemed worthy. Hence he became the patron of prisoners. He died in peace A.D. 599, and became very famous both in France and in England. He is sometimes represented as a deacon, and sometimes as a Benedictine abbot, with pastoral staff and book. Often he has chains or fetters in his hands, or a prisoner chained near him. [Sar. Ep. and Gosp.: Ecclus. xxxix. 5—9. St. Luke xi. 33—36.]

11] **ST. MARTIN, BISHOP AND CONFESSOR.**—St. Martin was the son of a Roman military tribune in Constantine's army, and was born in Hungary about A.D. 316. He became a catechumen while yet a child, and was compelled to enter the army in his fifteenth year, but nobly gave away in alms the whole of his pay except what he required for his subsistence. The well-known story of his dividing his military cloak with his sword, and giving half to a poor naked beggar at the gate of Amiens, is recorded by St. Sulpicius. It is said that he afterwards saw in a dream our Lord in the half of the cloak he had given to the poor man, and thought he heard Him say, "Martin, who is but a catechumen, hath covered Me with this garment." This dream at once determined him to receive holy Baptism, being about eighteen years old. Two years after this he sought his discharge, but being reproached with cowardice, he offered to face the enemy unarmed at the head of his troop, protected only by the sign of the Cross. Peace ensuing, he was released from further service. He then retired into solitude, from which he was withdrawn by St. Hilary, Bishop of Poitiers, who wished to ordain him deacon, but he would only consent at that time to be an exorcist. While on his way to visit his parents he was attacked by robbers, one of whom was converted on the spot. His mother and many of his countrymen were also converted, but his father remained a Pagan. He now met with great persecution from the Arians, who being at the height of their power, had succeeded in expelling St. Hilary from his bishopric, A.D. 356. St. Martin retired into solitude near Genoa, but about A.D. 360 rejoined St. Hilary, who had been restored to his see, and founded a monastery, said to have been the first in Gaul. The see of Tours becoming vacant, he was obliged against his will to accept it, but he determined to live a hermit's life notwithstanding. This, as in the case of St. Leonard, ended in his gathering around him a large number of recluses, which led to the establishment of one of the largest abbeys in France. St. Martin died November 8th, A.D. 397, and was buried at Cande, a monastery at the extremity of his diocese. [See July 4th.] St. Martin's cope (*cappa*) used to be carried into battle, and kept in a tent where Mass was said; hence the origin of the term *capella*, as applied to places for religious services other than parish churches. In process of time, a blue banner, divided to represent St. Martin's cloak, was carried instead, until it in turn was eclipsed by the famous *Oriflamme*, or banner of St. Denys. The ancient Gauls held St. Martin in such veneration that they even reckoned their years from the day of his death. "Martinmas" is still one of the four Cross-quarter days, coinciding with the Roman *Vinalia*; hence, perhaps, the origin of Martinmas festivities. There are no less than 160 churches dedicated to St. Martin in England alone, and he was still more popular in France. He is generally represented dividing his cloak with the beggar. [Sar. Ep. and Gosp.: Ecclus. xlv. 17, 20, 21—23; xlv. 6, 7, 15, 16. St. Matt. xxv. 14—23.]

13] **ST. BRITUS, BISHOP.**—St. Britius, or Brice, was an inmate of the religious house presided over by St. Martin, but gave much offence by his irregularities of conduct. St. Martin, however,

seeing in him the germ of good, ordained him deacon and priest, and foretold that he would one day succeed him in the see of Tours. Before the death of St. Martin a crisis came about in the spiritual life of Britius. Having been severely rebuked by his master, he reviled him in return, but soon repented, and bitterly lamented his former evil ways. On the death of St. Martin he was elected to succeed him, but his former sins were visited on him in this world, for he was grossly slandered, and banished from his see for seven years. He then returned, and remained in quiet possession for seven years more, after which he died, A.D. 444. He was buried near to St. Martin, in a chapel which he had himself built over the tomb of his spiritual father. He is represented as a Bishop with a child in his arms, or with burning coals in his hands or chasuble, in allusion to the belief that he was the first to undergo the Fiery Ordeal which afterwards became so general among Northern nations. [Sar. Ep. and Gosp.: Wisd. x. 10—14. St. Luke xix. 12—28.]

15] **ST. MACHUTUS, BISHOP.**—This saint, known also as St. Malo, (a Welshman,) was baptized and educated by the Irish Abbot of a monastery in the valley of Llan Carvan, where he was born. During the civil commotions of the age he fled into Brittany, and there led an ascetic life in an island, whence he used to go and preach to the pagans on the mainland. About A.D. 541 he was appointed Bishop of Aleth, but was driven by persecution to take refuge in Aquitaine. In his old age he was enabled to visit his people again, and give them his blessing. He died A.D. 564, while on his way to visit St. Leontius, Archbishop of Saintes, who had befriended him in his exile. The town of St. Malo is named from his body having once rested there. He is represented as a Bishop, with a child at his feet. [Sar. Ep. and Gosp.: Ecclus. xlv. 17, 20—23; xlv. 6, 7, 15, 16. St. Luke xix. 12—28.]

17] **HUGH, BP. OF LINCOLN.**—St. Hugh, or Hugh de Grenoble, was born of a noble Burgundian family, A.D. 1140. Ordained at the age of nineteen, he joined the Carthusians, or Reformed Benedictines, and about A.D. 1181 came to preside over the first Carthusian monastery in Britain, at Witham, in Somersetshire, at the request of its royal founder, Henry II. Five years after, the see of Lincoln having been long vacant, the King directed the dean and chapter to elect a new bishop, and to his great satisfaction they decided on the Prior of Witham. He reluctantly accepted his new office; but, once consecrated, discharged his episcopal duties in a most exemplary manner, yearly retiring, however, to his old monastery, and living as a brother, with no other distinction than the episcopal ring. He was overtaken by his last illness on his way back, after one of these visits, and died Nov. 17, A.D. 1200, as the clergy were singing the Compline *Nunc Dimittis* in his presence. He was solemnly buried in Lincoln Minster, a great part of which had been built under his direction; and two years later his body was translated to the shrine behind the high altar. It is a curious fact that in some Lincolnshire churchwardens' accounts, of the time of Queen Elizabeth, are frequent entries relative to ringing the bells on the 17th of November, the anniversary of her accession, but that it is almost always called *St. Hugh's Day*. Such entries are also extant in the books of St. Mary Magdalen, Oxford, of which church two aisles were built by St. Hugh. The latter entries range from 1577 to 1603. In Clew Church is a venerable memorial of St. Hugh in the original dedication inscription: H · ECCL'IA · DEDICATA · EST · IN · HONORE · S'CE · T'NITATIS · ET · S'CE · MARIE · V · III · N · MARTII · A · DNO · HVGONE · LINCOLNIE · SI · EP · O · ANNO · AB · T · CARNACIONE · DNI · M · C · XC · II · 0 · 8 · TE · PORE · RICARDI · REGIS. [Sar. Ep. and Gosp.: Ecclus. xlv. 1—5. St. Mark xiii. 33—37.]

20] **ST. EDMUND, KING AND MARTYR.**—This Saxon saint was born A.D. 841, and was crowned King of East Anglia in the fourteenth year of his age. He lived a most saintly life, and restored the churches and monasteries that had been destroyed in the recent wars. About A.D. 870, the Danes made an incursion on our eastern shores, ravaging churches and monasteries wherever they came. Edmund gave them battle, but finding it a hopeless case, fled to a church, and earnestly prayed for constancy in the sufferings which he saw impending. The Danes dragged him

DECEMBER hath 31 Days.

			Morning Prayer.		Evening Prayer.		
			1 Lesson.	2 Lesson.	1 Lesson.	2 Lesson.	
1	f	Calendæ.	Isa. 14	Acts 2	Isa. 15	Heb. 7	
2	g	4. Non.	16	3	17	8	
3	A	3. Non.	18	4	19	9	
4	b	Pr. Non.	20, 21	5	22	10	
5	c	Nonæ.	23	6	24	11	
6	d	8. Id.	25	7 to v. 30	26	12	
7	e	7. Id.	27	7	28	13	
8	f	6. Id.	29	8	30	James 1	
9	g	5. Id.	31	9	32	2	
10	A	4. Id.	33	10	34	3	
11	b	3. Id.	35	11	36	4	
12	c	Pr. Id.	37	12	38	5	
13	d	Idus.	39	13	40	1 Pet. 1	
14	e	19. Cal. Jan.	41	14	42	2	
15	f	18. Cal.	43	15	44	3	
16	g	17. Cal.	45	16	46	4	
17	A	16. Cal.	47	17	48	5	
18	b	15. Cal.	49	18	50	2 Pet. 1	
19	c	14. Cal.	51	19	52	2	
20	d	13. Cal.	53	20	54	3	
21	e	12. Cal.	Fast.	21	55	1 John 1	
22	f	11. Cal.	S. Thomas, Apostle and Martyr.	22	56	2	
23	g	10. Cal.		23	58	3	
24	A	9. Cal.	Fast.	24	60	4	
25	b	8. Cal.	Christmas Day.				
26	c	7. Cal.	S. Stephen, the first Martyr.				
27	d	6. Cal.	S. John, Apostle and Evangelist.				
28	e	5. Cal.	Innocents' Day.	25		5	
29	f	4. Cal.		61	62	2 John	
30	g	3. Cal.		63	27	64	3 John
31	A	Pr. Cal.	Silvester, Bishop of Rome.	65	28	66	Jude

Comparative View of the Calendar for DECEMBER.

	Bede, A.D. 735.	Salisbury Use, A.D. 1514.	Modern Roman.	Eastern.
1				Nahum the Prophet.
2			St. Bibiana.	Habakkuk the Prophet.
3			St. Francis Xavier.	Zephaniah the Prophet.
4		St. Osmund.	SS. Peter Chrysologus and Barbara.	SS. Barbara and John Da-
5			SS. Birinus and Sabbas.	St. Sabbas. [mascene.
6		St. Nicolas.	St. Nicolas.	St. Nicolas.
7			St. Ambrose.	St. Ambrose.
8		Conception of B. V. Mary.	Conception of B. Virgin Mary.	
9				Conception of St. Anne.
10				
11	St. Damasus.		St. Damasus.	
12				St. Spiridion.
13		St. Lucy.	St. Lucy.	St. Lucy.
14				
15				
16		O Sapientia.	St. Eusebius.	Haggai the Prophet.
17	St. Ignatius.			Daniel the Prophet and the [three children.
18			Expectation of Blessed Virgin Mary.	St. Sebastian and his Com- [panions.
19				
20				St. Ignatius.
21	St. Thomas.	St. Thomas.	St. Thomas.	St. Juliana.
22				
23	St. Eugenia.			
24				St. Eugenia.
25	Nativity of our Lord.	Nativity of our Lord.	Nativity of our Lord.	Nativity of our Lord.
26	St. Stephen.	St. Stephen, Proto-martyr.	St. Stephen, Proto-martyr.	SS. Mary and Joseph.
27	St. John, Evangelist.	St. John, Evangelist.	St. John, Evangelist.	St. Stephen.
28	Innocents.	Holy Innocents.	Holy Innocents.	
29		St. Thomas, Abp. of Can-	St. Thomas of Canterbury.	Holy Innocents.
30		[terbury.		
31	St. Silvester.	St. Silvester.	St. Silvester.	

THE MINOR HOLYDAYS OF NOVEMBER (*continued*).

forth, and scourged him; then binding him to a tree, they pierced him to death with many arrows, and having cut off his head, cast it into a thicket. Here it was found about a year after, and placed with his body. In A.D. 903 his remains were translated to the place now called Bury St. Edmunds, where an abbey was founded. He is represented crowned, clothed, tied to a tree, full of arrows, and frequently with the arms of the abbey (*az.* 3 crowns *or*, each pierced with two arrows in saltier of the second). By this and the crown he is distinguished from St. Sebastian, who is moreover represented almost without clothing. [Sar. Ep. and Gosp.: Ecclus. xxxi. 8—11. St. Luke xiv. 26—33.]

22] ST. CECILIA, VIRGIN AND MARTYR.—The name of St. Cecilia has always been dear in connexion with music, of which she is considered the patron. Very little, however, is known about her personal history, which is much mixed up with legends. Dryden alludes to one of these legends in the well-known lines:—

"He raised a mortal to the skies,
She drew an angel down."

Her husband Valerian had been converted through her, and suffered martyrdom with her, A.D. 230, or, according to some, about fifty years earlier. A church was dedicated to her honour at Rome early in the sixth century, and still gives a title to a Cardinal. It appears pretty certain that her body was discovered there A.D. 1599. The "Acts of St. Cecilia" describe her as having been frequently employed in music, and accordingly she is represented singing, and playing on a small organ or other instrument. She is also figured as being scalded to death in a caldron, or holding a sword as well as a musical instrument. [Sar. Ep. and Gosp.: Ecclus. li. 9—12. St. Matt. xiii. 44—52.]

23] ST. CLEMENT, BISHOP OF ROME, AND MARTYR.—We know very little about the early history of St. Clement, but he has

always been believed to be the "fellow-labourer" mentioned by St. Paul (Phil. iv. 3) as having his name "written in the Book of Life." From his having been contemporary with the Apostles, he is reckoned among the "Apostolical Fathers," and is called "Clemens Romanus," to distinguish him from Clement of Alexandria. In A.D. 91 he was made third Bishop of Rome, where he remained through the persecution of Domitian. About A.D. 96, the year of this tyrant's death, St. Clement wrote his First Epistle to the Corinthians, which was publicly read in the Churches, and for a long time esteemed almost equally with the Canonical Epistles. He probably suffered under Trajan, about A.D. 100, being cast into the sea bound to an anchor, which is his distinguishing emblem, as may be seen in some frescoes of the 7th century, lately discovered in St. Clement's Church at Rome. [Sar. Ep. and Gosp.: Phil. iv. 1—3. St. Luke xix. 12—28.]

25] ST. KATHARINE, VIRGIN AND MARTYR.—There is very little reliable information respecting St. Katharine, but her name has been highly venerated in both East and West. She is said to have been royally descended, and of great learning and ability, so that she confuted even heathen philosophers, with whom she had to dispute before Maximin the Emperor, and was the means of their conversion. They, confessing Christ, were burnt to death, but the saintly woman was reserved for a further trial. Refusing to sacrifice her chastity to the lust of the tyrant, she was first torn on spiked wheels, and then slain with a sword. In the eighth century her body was translated to the monastery of Mount Sinai by holy monks, who in mediæval legends were transformed into angels. St. Katharine is accounted the patron of secular, as St. Jerome is of theological, learning. She is represented crowned, with the martyr's palm, or a book, or sword, in her hand, and the spiked wheel by her side. [Sar. Ep. and Gosp.: Ecclus. li. 1—8. St. Matt. xiii. 44—52.]

THE MINOR HOLYDAYS OF DECEMBER.

6] ST. NICOLAS, BISHOP AND CONFESSOR.—St. Nicolas was a native of Patara, in Asia Minor; and having grown up in the fear of God, was appointed abbot of the monastery of the Holy Zion. Some time after this he was made Bishop of Myra, in Lycia, and here acquired a great reputation for sanctity and deeds of charity. He died A.D. 342, and was buried in his church at Myra, whence his remains were carried off, in A.D. 1087, to Bari on the Adriatic, for fear they should be desecrated by the Mohammedans. This was done by some merchants, and St. Nicolas has hence been accounted the patron of merchants and seafaring men. Many of the churches dedicated to him are at seaport towns. He is also considered the patron of children and schoolboys, from his remarkable humility and simplicity, and because he took great interest in their instruction. He is represented as a Bishop, with three golden balls, the original significance of which is not known; also with children around him being raised to life from a tub, in which their murdered bodies had been concealed; also with an anchor or ship. The mediæval ceremonies connected with the "Boy-bishop" began on St. Nicolas' day, and lasted till Childermas or Holy Innocents' day. [Sar. Ep. and Gosp.: Ecclus. xlv. 17—23; xlv. 6, 7, 15, 16. St. Matt. xxv. 14—23.]

8] CONCEPTION OF THE B. V. M.—It appears probable that a belief in the "Immaculate Conception" led to the original institution of this festival, though it may be regarded as celebrating the joyful dawn of the Incarnation of our Lord without any particular reference to the novel doctrine. Its observance began in the East in early times, but did not become general in the West till the fifteenth century. Its introduction into Britain has been ascribed, on doubtful grounds, to St. Anselm, long after whose time the observance of it was optional. [Sar. Ep. and Gosp.: Ecclus. xxiv. 17—22. St. Matt. i. 1—16.]

13] ST. LUCY, VIRGIN AND MARTYR.—St. Lucy was the daughter of a Christian lady in Syracuse, named Eutychia, and was born in the latter part of the third century. Being asked in marriage by a young nobleman of Syracuse, who was a pagan, she declined his suit, having made a private vow of celibacy long before. Her

mother was not aware of this, and wished her to marry the youth; but being restored from dangerous sickness at the prayers of her daughter, no longer opposed her resolution, of which, indeed, she now became aware for the first time. St. Lucy then sold all her goods to feed the poor, and openly professed her dedication to Christ. The young nobleman now hated her, and accused her before the Governor Paschasius, during the Dioclesian persecution. She boldly confessed Christ before her judges, and was condemned to what was far worse than death, but was delivered by God. After this she was tortured by fire, and her flesh torn with hot pincers, soon after which she died in prison, without having failed in her most severe trial, about A.D. 304. St. Lucy bears the martyr's palm, a lamp, in allusion to her name and a book, or dish, on which are two eye-balls, while sometimes rays of light are emitted from a wound in her throat. She also has the pincers fastened on to her breast. The festival of St. Lucy regulates the Ember Days in December. [Sar. Ep. and Gosp.: Ecclus. li. 9—12. St. Matt. xiii. 44—52.]

16] O SAPIENTIA.—These words mark the first of the days on which the eight Greater Antiphons were sung. [See p. 76.]

31] ST. SILVESTER, BP. OF ROME, AND CONFESSOR.—St. Silvester was born at Rome in the latter part of the third century, and was ordained priest just before the Dioclesian persecution, during which he was well known among the faithful for his zeal and piety. He was made Bishop of Rome A.D. 314, and was summoned to attend the Councils of Arles and Nice, but was unable through weak health to be present in person. Having filled the see for nearly twenty-two years, he died, Dec. 31, A.D. 335, and was buried in the cemetery of Priscilla on the Salarian Way, whence his remains were removed to a church dedicated in his name about the end of the seventh century. There is a tradition respecting him, that he restored an ox to life which had been killed by magic; and the ox is accordingly his distinguishing emblem. He is represented as a Bishop, holding the cross and book, or the portraits of St. Peter and St. Paul. [Sar. Ep. and Gosp.: Ecclus. l. 1, 4, 5—12. 15. 21—23. St. Matt. xxv. 14—23.]

AN INTRODUCTION

TO

MORNING AND EVENING PRAYER.

THE ordinary daily Offices of the Christian Church were derived from the Jewish economy; the celebration of the Holy Eucharist being the distinctive devotional characteristic of Christianity. As David sang, "seven times a day do I praise Thee" [Ps. cxix. 164]; and as Daniel "kneeled upon his knees three times a day, and prayed, and gave thanks before his God" [Dan. vi. 10], so down to that period during which the old and the new economy overlapped each other, a constant habit of praise and prayer in connexion with the morning and evening sacrifice, and at other hours of the day, was maintained in the Temple at Jerusalem, and in the Synagogues elsewhere. The Apostles continued the practice of devout Jews, and are spoken of in the book of their Acts as being in the Temple at the hour of prayer, or as offering their prayers elsewhere at the same hour. It was while "they were all with one accord in one place" at "the *third hour* of the day" [Acts ii. 1. 15] that the Holy Ghost descended upon them: "Peter went up upon the house-top to pray about the *sixth hour*" [Ibid. x. 9]: "Peter and John went up together into the temple at the hour of prayer, being the *ninth hour*" [Ibid. iii. 1]: "at midnight Paul and Silas prayed and sang praises unto God" [Ibid. xvi. 25]: and in the early zeal of their first love all the believers "continued stedfastly . . . in the prayers" [τὰς προσευχαίς] "daily with one accord in the Temple" [Ibid. ii. 42. 46], as a regular part of the system of that fellowship into which they had been baptized.

When the habits of the Church began to be settled, it appears that the opening and the close of each day were appointed as the principal hours of prayer; and that the three intermediate times, the third, sixth, and ninth hour, were still recognized, and marked by public worship. Tertullian, after giving the Scriptural examples cited above, goes on to say that though these "stand simply without any precept for their observance, yet let it be thought good to establish any sort of presumption which may both render more strict the admonition to pray, and, as it were by a law, force us away sometimes from our business to this service, (even as was the custom of Daniel also, according no doubt to the rule of Israel,) that so we should pray at least not seldomer than three times a day, we who are debtors to the Three, the Father, and the Son, and the Holy Ghost, *exclusive, that is, of the regular prayers which are due, without any admonition, at the beginning of day and night.*" [Tert. de Orat. ix. 26.] In his treatise on fasting he also calls the third, sixth, and ninth hours, "Apostolic hours of prayer." St. Cyprian refers to the habits of Old Testament saints, and draws the rational conclusion that the events of the Gospel gave proof that there was a "sacrament," or mystery, in the ancient practice of

righteous men offering prayers at these seasons, as if the spiritual instincts of good men were already moving in the light of the Cross. "But to us, dearest brethren," he says, "besides the hours of ancient time observed, both seasons and sacraments of prayer are increased in number. In the morning we must pray," not waiting, that is, for the third hour, "that the Resurrection of the Lord may be commemorated with an early worship. This of old the Holy Spirit set forth in the Psalms, saying, 'My King and My God, unto Thee will I cry: My voice shalt Thou hear in the morning; in the morning will I stand before Thee, and will look up.' [Ps. v. 2.] And again, by the prophet the Lord saith, 'Early in the morning shall they seek Me, saying, Come and let us return unto the Lord our God.' [Hosea vi. 1.] At sunset likewise, and the close of day, needful is it that we should again pray. For as Christ is the true Sun and the true Day, when at the going down of this world's sun and light we make prayer and petition that the day may again return unto us, we are petitioning for that coming of Christ, which will give to us the grace of the Light eternal." [Cyprian. de Orat. Dom. xxi.] In the Apostolical Constitutions the same habit of the Church is referred to in very distinct terms: "Ye shall make prayers . . . In the *morning* giving thanks, because the Lord hath enlightened you, removing the night, and bringing the day: at the *third hour*, because the Lord at that time received sentence from Pilate; at the *sixth hour*, because in it He was crucified; at the *ninth hour*, because all things were shaken when the Lord was crucified, trembling at the audacity of the impious Jews, not enduring that their Lord should be insulted; at *evening* giving thanks, because He hath given the night for rest from our daily labours; at *cock-crowing*, because that hour gives the glad tidings that the day is dawning in which to work the works of light." [Apostol. Constit. viii. 34.]

No account has come down to us which tells exactly of what these Primitive daily Offices consisted; but St. Basil in the fourth century speaks of them as being made up of psalmody mingled with prayers, and specifies the nineteenth psalm as one which was invariably used at the sixth hour. The fifty-first psalm is also shown, from him and other writers, to have been constantly used in the night service; and the sixty-third was called the "Morning Psalm," being used at the beginning of the early service. The "Gloria in Excelsis" is also spoken of by St. Chrysostom as "the Morning Hymn" [see note in Communion Service], and the repetition of the Kyrie Eleison many times seems to have formed another part of these ancient services.

The daily Offices of the Eastern Church are of greater antiquity than those of the Western, and there is little doubt that

they represent, substantially, the form into which the Primitive Offices for the hours of Prayer eventually settled down¹. Sufficient points of resemblance have been traced between these and the daily prayers used under the Jewish economy, to make it almost certain that the former were originally derived from the latter². But there are also many particulars in which the Western daily Offices, and especially those of the English Church, are analogous to those of the East, and although they cannot be traced higher, in their familiar form, than the Rule of St. Benedict [A.D. 530], it can hardly be doubted that men like St. Benedict and Gregory would build upon the old foundations of Primitive Services, such as those now represented by the hours of the Eastern Church. In the Ancient Sacramentaries there are several series of Collects for daily use: one set of twenty-three in that of St. Gregory, being entitled "Orationes de Adventu Domini quotidianis diebus;" another, of twenty, apparently for Lent, being headed "Orationes pro peccatis;" a third of many more in number being called "Orationes quotidianæ." There are also other sets in the same Sacramentary, "ad Matutinos luculentiores," "Orationes Matutinales," "Vespertinales," and "ad Completorium." What place such Collects occupied in the daily Offices is not quite clear, but they plainly show that the Primitive habit of the Church was kept up, and that daily prayers were continually being offered in the Western as well as in the Eastern Church. Lessons from Holy Scripture were only read in the Synagogue on the Sabbath day; in the Temple none at all (except the Decalogue) were ever read. This custom was continued throughout the Church even until the time of St. Gregory: Epistles and Gospels being read at the Holy Communion, but no Lessons at the hours of Prayer. St. Gregory established a system which afterwards developed into that of the Breviary Lessons, but in the Eastern Church the Primitive practice of reading Holy Scripture at the celebration of the Eucharist, and on Sunday only at other offices, is still maintained.

In Mediæval times the daily Offices were developed into a very beautiful, but a very complex form; being moulded exclusively to the capacities of clergy and laity living in communities, separated from the world especially for a work of prayer and praise, which was seldom interrupted by the calls of other avocations. Those used in England differed in several important respects from the Roman Breviary³, and are supposed to have had the same origin as the Communion Office, the lineage of which is traced at p. 147 to the Church of Ephesus. Like those of the Eastern and Roman Churches, they consisted nominally of seven separate services or hours [see p. xxviii], but as in those churches

at the present day these seven hours are aggregated into three, or even two services, so it is probable was the case, to a great extent, in the Mediæval Church of England, and the whole seven were only kept by a small number of the most strict among the Clergy and religious. The Reformers *condensed* the seven hours, instead of *aggregating* them, and thus gave us Mattins and Evensong, as in the manner shown by the Table at p. xxix. At the same time, the publication of Edward VI.'s and Queen Elizabeth's Primers showed that they by no means intended to hinder, but rather to encourage those who still wished to observe the ancient hours of Prayer: and the Devotions of Bishop Cosin, with other Manuals framed on the same model, have given many devout souls the opportunity of supplementing the public Mattins and Evensong with prayers at other hours that equally breathed the spirit of the ancient Church.

In making this change the Reformers were doubtless endeavouring to secure by a modification of the Services what the theory of the Church had always required, the attendance of the Laity as well as the Clergy at the Daily Offices of Praise and Prayer. From very early days the Church of England had enjoined the Laity to be present at them, as may be seen in the collection of Decrees and Canons on the subject printed by Maskell [Mon. Rit. Ang. II. xxv.—xxxii.]; but these injunctions appear to have been little obeyed, and their constant absence led the clergy to deal with the Breviary as if it was intended for their own use alone, its structure becoming so complex that none but those who had been long used to handle it could possibly follow the course of the services day by day. In forming out of these complex services such simple and intelligible ones as our present Morning and Evening Prayer, a new opportunity was offered to the Laity of uniting their hearts and voices with those of the Clergy in a constant service of daily praise and prayer.

Churches without such an offering of Morning and Evening Prayer are clearly alien to the system and principles of the Book of Common Prayer; and to make the offering in the total absence of worshippers seems scarcely less so. But as every Church receives blessing from God in proportion as it renders to Him the honour due unto His Name, so it is much to be wished that increased knowledge of devotional principles may lead on to such increase of devotional practice as may make the omission of the daily Offices rare in the Churches of our land. Then indeed might the time come when the Church of England could say, "Thou, O God, sentest a gracious rain upon Thine inheritance; and refreshedst it when it was weary." It might look for the development of a perennial vigour springing from that "third hour of the day" when the Apostles first went forth in the might of their supernatural endowments; and hope to meet with answers from on high, as sure as that which was given to Elijah "about the time of the Evening Sacrifice."

¹ They are given at length in Neale's *Introd. Hist. of Eastern Church*, l. ii. ch. iv.

² *Ibid.* Freema's *Princ. Div. Serv.* i. 65. ³ *Ibid.* 106. ⁴ *Ibid.* 246.

PRAISED BE THE LORD DAILY: EVEN THE GOD WHO HELPETH US, AND POURETH HIS BENEFITS UPON US.

DAY BY DAY WE MAGNIFY THEE,

AND WE WORSHIP THY NAME: EVER WORLD WITHOUT END.

THE ORDER FOR
MORNING AND EVENING PRAYER

DAILY TO BE SAID AND USED THROUGHOUT THE YEAR.

THE Morning and Evening Prayer shall be used in the accustomed Place of the Church, Chapel, or Chancel; except it shall be otherwise determined by the Ordinary of the Place. And the Chancels shall remain as they have done in times past.

And here is to be noted, that such Ornaments of the Church, and of the Ministers thereof, at all times of their Ministration, shall be retained and be in use as were in this Church of *England*, by the Authority of Parliament, in the Second Year of the Reign of King *Edward* the Sixth.

The second part of this important Rubric—the Interpretation Clause to the Ritual Law of the Church of England—is fully explained and illustrated in the Third Section of the Ritual Introduction, p. lxxv.

The first part of it is still exactly in the form in which it was printed in the Prayer Book of Queen Elizabeth's reign [A.D. 1559]. In the Second Prayer Book of Edward VI., it stood in this form: "¶ The Morning and Evening Prayer shall be used in such place of the Church, Chapel, or Chancel, and the Minister shall so turn him, as the people may best hear. And if there be any controversy therein, the matter shall be referred to the Ordinary, and he or his deputy shall appoint the place, and the chancels shall remain as they have done in times past." In the Prayer Book of 1549 the rubric at the head of Morning Prayer was, "The Priest being in the quire, shall begin with a loud voice the Lord's Prayer, called the *Pater noster*."

The "reading-desk" was not invented until after the rubric had taken its present form, and the "accustomed place" was the "pue" (beginning then to be so called) in which the Clergy and singers sat, and which was ordinarily situated on either side of the chancel. In the Advertisements of 1565, it was directed "that the Common Prayer be said or sung decently and distinctly, in such place as the Ordinary shall think meet for the

largeness and straitness of the church and choir, so that the people may be most edified." [Cardw. Docum. Ann. i. 291.] Such lawless bishops as Scambler of Peterborough, who knew no rule but "*sic volo, sic jubeo*," forbade the service to be said in the chancel at all, under the singular plea used against it by the foreigner Bucer, that such a practice was "Antichristian." Thus the erection of reading-desks in the nave became common, the "clerks" were reduced to one, the authorized mode of Divine Worship died out in a vast number of churches during the seventeenth and eighteenth centuries, and instead of the chancels remaining as they had done in times past, they were too often looked on either as a kind of lumber-room, to be cleared out once a quarter for the administration of the Holy Communion; or as a part of the church where the most comfortable and honourable seats were provided for the richer laity. Such customs have tended to obscure the sense of the rubric, and are recalled to memory only for the purpose of explaining how it came to be so disregarded in modern times. In *Griffin v. Dighton*, Chief Justice Erle decided (on appeal in 1864) that the chancel is the place appointed for the Clergyman and for those who assist him in the performance of Divine Service; and that it is entirely under his control as to access and use, subject to the jurisdiction of the Ordinary.

THE
ORDER
FOR
MORNING PRAYER,
DAILY THROUGHOUT THE YEAR.

Pro prior officio. Rubric. ¶ At the beginning of Morning Prayer the Minister shall read with a loud voice some one, or more of these Sentences of the Scriptures, that follow. And then he shall say that which is written after the said Sentences.

Ps. cxviii. 27. **W**HEN the wicked man turneth away from his wickedness, that he hath committed, and doeth that which is lawful and right, he shall save his soul alive.

I acknowledge my transgressions, *Ps. li. 3.* and my sin is ever before me.

Hide thy face from my sins, and *Ps. li. 9.* blot out mine iniquities.

The Sacrifices of God are a broken *Ps. li. 17.* spirit: a broken and a contrite heart, O God, thou wilt not despise.

Rend your hearts, and not your garments, and turn unto the Lord your

The Order for Morning Prayer.] The word "Order" in the title here intended has almost passed out of use. It simply means regulation or ordinance, according to its derivation from the Latin word *ordo*. Morning Prayer was called by the ancient name of "Mattins" (abbreviated from *Matutinæ*), in the English Prayer Book of 1549; and that name is still retained in the three Tables of Proper Lessons and Proper Sentences, and also in the Elizabethan Act of Uniformity.

THE SENTENCES.

The ancient Mattins of the Church of England began with, "In the name of the Father, and of the Son, and of the Holy Ghost," (and the sign of the Cross,) followed by an inaudible recitation of the Lord's Prayer by the Priest who officiated. Then was said "O Lord, open Thou my lips: And my mouth shall shew Thy praise." This opening of the service was retained in the 1549 Prayer Book, but the Lord's Prayer was directed to be said "with a loud voice," instead of *secreto*. In the 1552 Prayer Book, these Sentences, with the Exhortation, Confession, and Absolution, were prefixed to Morning Prayer, but not to the Lord's Prayer. This addition was suggested, probably, by the reformed Breviary of Cardinal Quignonez, in which the Confession and Absolution, hereafter given, were placed at the beginning of Mattins. But other reasons are also apparent

for the change. In the first place, the full effect of the dissolution of Monasteries was making itself felt by ritualists, and a penitential prefix to the service was considered more appropriate for a mixed congregation than the previous mode of opening it, which was suitable for communities professedly spending nearly their whole time in the religious portion of a Christian's duty. And, in the second place, a relaxation of the rule about private Confession made it expedient to place a public Confession and Absolution within the reach of all, day by day.

The Sentences themselves (which had nearly all been previously in use as *Capitula*, during Lent) are a reproduction at the beginning of Divine Service of the Invitatories which were prefixed to the *Venite* in the ancient Mattins. In both cases the object is to give the key-note to the service which is to follow. In the Salisbury use two such Sentences, with a Versicle and Collect, were prefixed to Mattins on Easter Day. These were still ordered to be "solemnly sung or said" in the same place in the 1549 Prayer Book; but on the appointment of the Sentences now in use, the former were directed to be used instead of *Venite*, and are printed before the Easter Collect. It was in this light that the Sentences were viewed by Bp. Andrewes, who suggested some others in the following note: "Adde huc, quod ad invitandam penitentiam egregia sunt misericordiae et longanimitatis encomia. *Ps. lxxviii. 88. Jer. iii. 7. 12. Heb. iv.*"

B

. 110664

God: for he is gracious, and merciful, slow to anger, and of great kindness, and repenteth him of the evil.

Dan. ix. 9, 10. To the Lord our God belong mercies and forgivenesses, though we have rebelled against him: neither have we obeyed the voice of the Lord our God, to walk in his laws, which he set before us.

Jer. x. 24.
Ps. vi. 1. O Lord correct me, but with judgement; not in thine anger, lest thou bring me to nothing.

Matt. iii. 2. Repent ye; for the Kingdom of Heaven is at hand.

Luke xv. 18, 19. I will arise and go to my Father, and will say unto him; Father, I have sinned against Heaven, and before thee, and am no more worthy to be called thy son.

Ps. cxliii. 2. Enter not into judgement with thy servant, O Lord; for in thy sight shall no man living be justified.

1 John i. 8, 9. If we say that we have no sin, we deceive our selves, and the truth is not in us. But, if we confess our sins, he is faithful and just to forgive us our

sins, and to cleanse us from all unrighteousness.

DEARLY beloved brethren, the Scripture moveth us in sundry places to acknowledge and confess our manifold sins and wickedness, and that we should not dissemble nor cloak them before the face of Almighty God our heavenly Father, but confess them with an humble, lowly, penitent, and obedient heart, to the end that we may obtain forgiveness of the same, by his infinite goodness and mercy. And although we ought at all times humbly to acknowledge our sins before God, yet ought we most chiefly so to do, when we assemble, and meet together, to render thanks for the great benefits that we have received at his hands, to set forth his most worthy praise, to hear his most holy word, and to ask those things, which are requisite and necessary, as well for the body as the soul. Wherefore I pray and beseech you as many as are here present, to

Phil. iv. 1.

See the above sentences.

Lev. v. 5.

Josh. vii. 19.

Prov. xxviii. 13.

Ps. xxvi. 4.

John xv. 22.

Gen. xvii. 1.

Matt. vi. 14.

Jer. iii. 13.

Ps. li. 3. 17.

Matt. iii. 2.

Isa. iv. 7.

Joel ii. 13, 14.

Ps. lxxxvii. 5.

* Ps. xxxviii. 18.

Luke. xviii. 13.

14.

Joel i. 14.

Hos. xiv. 1, 2.

2 Chron. vi. 18-

21. vii. 16.

Ps. c. 4.

xxxv. 18.

1 Chron. xvi. 8, 9.

Ps. cxlix. 1.

* xcv. 2.

Deut. xxxi. 11, 12.

Acts xiii. 44.

2 Chron. vii. 13.

Isa. lvi. 7.

Matt. vii. 6. 11.

As Invitatories intended to give the key-note to the Service, they may be advantageously used in the following, or some similar, order, appropriate to the various days and seasons.

Advent: "Repent ye." "Enter not." "O Lord, correct me."

Lent: "The sacrifices." "Render your heart."

Fridays and Vigils: "I acknowledge."

Wednesdays: "Hide thy face."

Ordinary days: "When the wicked man." "I will arise."

"If we say."

Sundays, other holy days, and Eves: "To the Lord our God."

There is a well-known traditional practice of singing one of these Sentences as an anthem; "I will arise" being very frequently so used. Such a practice seems to be in strict keeping with their character as Invitatories, and in analogy with the use of the Easter Sentences referred to; as also with such a use of the Offertory Sentences in the Communion Service.

Read with a loud voice] This is an ecclesiastical or technical phrase, the explanation of which is to be found in a Rubric before the *Te Deum* in the previous editions of the Prayer Book: "Then shall be read two Lessons distinctly with a loud voice." "Then shall the Lessons be sung in a plain tune, after the manner of distinct reading; and likewise the Epistle and Gospel." It is the *clara vox* of older ritualists, and presupposes a musical intonation, with or without inflection, to be the customary way of reciting Divine Service. "To syng & rede & say." [Mirror, f. 5.]

In Bishop Cosin's revision he appended to the word "minister" the following note:—"That is, he who at that time ministereth or celebrateth Divine Service;" and although it was not deemed necessary at the time to print this note, it is valuable to us now as showing the technical meaning which was attached to the word Minister, when used in the Rubric. He also added Isaiah lv. 6, 7, and 1 John i. 9, the latter verse being adopted, but not the former; and "or more" after "some one" in the Rubric.

Some may consider that the terms of the Rubric, both here and before the Offertory Sentences, strictly limit the recitation of them

to the clergyman officiating. There is, however, no ritual principle by which they are so limited.

THE EXHORTATION.

There is an analogy between this Exhortation and some which were used, at the Holy Communion and in Lent, in the ancient services of the Church of England. There is also a trace of similarity between it and the opening of Pullain's *L'Ordre des Prières Ecclésiastiques*, printed for the use of the German refugees at Glastonbury, in 1552. The words of the latter are, "Mes Frères, qu'un chacun de vous se présente devant la face du Seigneur, avec confession de ses fautes et péchez, suyvant de tout son cueur mes [pa]rolles." But there is too little resemblance between our Exhortation and these to give any critical ground for supposing that it was founded upon any of them; and it must be concluded that those who revised the Prayer Book in 1552 were entirely responsible for its composition.

It has been called a short homily on Divine worship; and may also be taken as following up the general Invitatory, as it was followed formerly by the *Venite*. It was probably inserted here under the impression that the people at large were extremely ignorant of the true nature of Divine worship at the time. Five principal parts of worship are mentioned in it. (1) Confession of sin; (2) Absolution; (3) Thanksgiving and Praise; (4) The hearing of God's Word; (5) Prayer for spiritual and bodily benefits. In this structure also it bears some analogy to the *Venite*.

The Minister celebrating Divine Service is directed to "say" this Exhortation, "saying" being the ritual term for reciting on one musical note, or "monotoning," as distinguished from "singing," which is reciting with musical inflections, and from "reading," which is a general term, including both methods. If the Exhortation is said from memory, and with the face turned towards the congregation, it becomes much more expressive of the intention with which it was placed here, than when said as a *recre*

¹ This book was also printed in Latin, perhaps before it came out in French. The French edition seems to be very rare.

2 Cor. x. 1. accompany me with a pure heart and
Acts iv. 24. humble voice unto the throne of the
Eccles. v. 1, 2. heavenly grace, saying after me.
Ex. xxv. 21, 22.
Heb. iv. 16.

† A general Confession to be said of the whole
Congregation after the Minister, all kneeling.

Isa. lxiii. 16.
Luke vi. 36.
Isa. llii. 6.
Ps. cxix. 176.
Jer. xviii. 12.

Jer. xvii. 9.
Eph. ii. 2, 3.

Dan. ix. 9, 10.

Rom. vii. 12.
1 John iii. 4.
Lam. iii. 40, 42.

ALMIGHTY, and most merciful
Father; We have erred, and
strayed from thy ways like lost sheep.
We have followed too much the devices
and desires of our own hearts. We
have offended against thy holy laws.
We have left undone those things
which we ought to have done; And

we have done those things which we
ought not to have done; And there is
no health in us. But thou, O Lord;
have mercy upon us, miserable of-
fenders. Spare thou them, O God,
which confess their faults. Restore
thou them that are penitent; Ac-
cording to thy promises declared unto
mankind in Christ Jesu our Lord.
And grant, O most merciful Father,
for his sake; That we may hereafter
live a godly, righteous, and sober
life, To the glory of thy holy Name.
Amen.

Isa. lix. 12, 13.

Gal. v. 17.
Ps. xxxviii. 3.
H. 1-5.

Luke xviii. 13.
Prov. xxviii. 13.

Joel ii. 17.

Jer. iii. 22.
Hos. xiv. 1, 2.

Ps. xxiii. 3.
H. 12.

Matt. i. 21.
Acts x. 36, 43.
2 Cor. i. 20.

1 John i. 9.
John xvi. 23, 24.
Titus ii. 11, 12.
John xv. 8.

Eph. iii. 20, 21.

form for passing away a few seconds, while the congregation is settling into a devotional frame of mind.

The concluding words, "after me," were erased by Bishop Cosin, for what reason is not apparent, and were restored by the Committee of Revision. They define the manner in which the Confession is to be said; as also do the words "humble voice," which represent the *submissa vox* of old rubrics.

THE GENERAL CONFESSION.

After the Minister, all kneeling] Bishop Cosin erased the word "after" in this Rubric, and substituted "with;" but the original word was carefully restored, showing that a distinction was intended between the two words in their ritual use. "After the Minister" means, that each clause is to be said first by the Minister alone, and then repeated by "the whole congregation" alone—i. e. while the Minister remains silent, as in the case of a response after a versicle. "With" the Minister means simultaneous recitation by him and the congregation together, and is ordered in the Rubric before the Lord's Prayer. The word "all" was also one of Bishop Cosin's additions, and is illustrated by his note in another volume: "Kneeling is the most fit gesture for humble penitents; and being so, it is strange to see how in most places, men are suffered to sit rudely and carelessly on their seats all the while this Confession is read; and others that be in church are nothing affected with it. They think it a thing of indifference forsooth, if the heart be right." This sitting posture during public confessions was one of the abuses that scandalized the Puritans; and they sought to have a Canon passed, enjoining all to kneel. The eighteenth Canon does indeed direct that "all manner of persons then present shall reverently kneel upon their knees when the general Confession, Litany, and other prayers are read . . . testifying by these outward ceremonies and gestures, their inward humility."

The gesture of kneeling here and elsewhere is not only a mark of personal humility and reverence, but also one of those acts required of every one as an individual component part of the body which forms the congregation; and to neglect it is to neglect a duty which is owing to God and man in this respect, as well as the other. We have no right to conspicuous private gestures in a public devotional assembly; nor are the gestures which we there use (in conformity to the rules of the Church) to be necessarily interpreted as hypocritical because our personal habits or feelings may not be entirely consistent with them. As the clergy have an official duty in church, irrespective of their personal characters, so also have the laity. It may be added, that a respectful conformity to rules enjoining such official duties, may often lead onward to true personal reverence and holiness.

As far as present researches show, the general Confession appears to be an original composition of some of the revisers of 1552; but its principal features are, of course, represented in con-

fessional formularies of the Ancient Church, the ideas being a common heritage of every age and country. It has not undergone any alteration since its first introduction into morning prayer.

It has been observed¹, that this general Confession appears to be founded on Romans vii. 8—25.

We have followed too much the devices and desires of our own hearts. Sin . . . wrought in me all concupiscence.

We have offended against Thy holy laws. The law is holy . . . but I am carnal, sold under sin.

We have left undone those things which we ought to have done. The good that I would, I do not.

We have done those things which we ought not to have done. But the evil which I would not, that I do.

And there is no health in us. In me dwelleth no good thing. O . . . the body of this death.

But Thou, O Lord, have mercy upon us miserable offenders. O wretched man that I am, who shall deliver me?

According to Thy promises, declared unto mankind in Christ Jesu our Lord. I thank God, through Jesus Christ our Lord.

All the phrases of the Confession have, however, a Scriptural ring; and it was very likely compiled almost *verbatim* from some old English version of the Bible, or else freely rendered (according to the habit of the day in sermons) from the Vulgate Psalms, and other Scriptures indicated above in the margin.

The manner and spirit in which a general confession of sins may be made personally and particularly applicable, is pointedly set forth in a Rubric which precedes the Confession to be used on board ship when there is danger of shipwreck: "When there is imminent danger, as many as can be spared from necessary service in the ship, shall be called together, and make an humble Confession of their sin to God, in which every one ought seriously to reflect upon those particular sins of which his conscience shall accuse him, saying as followeth." That a confession so made can be otherwise than acceptable to the Good Shepherd and Physician of our souls it is impossible to doubt. That further and more detailed confession is also at times necessary, the provisions made by the Church for her penitents, and the private habits of all pious Christians, make equally certain.

The "Amen" is part of the Confession, and is to be said by both minister and people, as is indicated by the type in which it is printed.

¹ Archd. Freeman's "Principles of Divine Service," i. 320.

¶ *The Absolution or Remission of sins to be pronounced by the Priest alone, standing; the people still kneeling.*

2 Cor. i. 3.

Ezek. xviii. 31, 32.
2 Pet. iii. 9.

Ezek. xxxiii. 11.

John xx. 21, 23.
Luke xxiv. 47.

2 Cor. ii. 10.
v. 18—20.
Isa. xliii. 23.
Ps. lxxxvi. 3.

Acts ii. 38. xiii.
38, 39.

ALMIGHTY God, the Father of our Lord Jesus Christ, who desireth not the death of a sinner, but rather that he may turn from his wickedness and live; and hath given power and commandment to his Ministers to declare and pronounce to his people, being penitent, the absolution, and remission of their sins: He pardoneth and absolveth all them that

[**L**ORD God, which dost not suffer sinners to perish and die in their works, but rather wilt that they shall convert and live, we humbly pray Thee to forgive us now while we have time and space

Marshall's Primer, at end of Litany.

Cf. Greg. Sabb. in xii. lect. mens. i.

. . . Misereatur vestri omnipotens Deus, et dimittat vobis omnia peccata vestra :

Salisbury Use.

THE ABSOLUTION.

by the Priest alone, standing] This Rubric stood in the form "by the Minister alone," until 1661. Bishop Cosin altered it to "by the Minister alone standing, and all the people still kneeling," and his alteration subsequently developed into the existing words byfore the revision was completed. The reason for inserting the word "standing" was that some of the clergy had been accustomed to read it on their knees, although, as Bishop Andrewes wrote, "because he speaks it *authoritative*, in the name of Christ and His Church, the Minister must not kneel, but stand up," and this posture was observed by the majority. The other three words, "the Priest alone," have a history which fixes their meaning. At the Savoy Conference of 1661, the Presbyterians' 11th "exception" to the Prayer Book was to the effect that as the word "Minister" was used in the rubric before the Absolution, and not "Priest," or "Curate," therefore it should be used instead of those words throughout the book. To this it was replied by the Church of England Commissioners that it would be unreasonable to use the word Minister alone, for "since some parts of the Liturgy may be performed by a Deacon, others by none under the order of a Priest, viz., Absolution, Consecration, it is fit that some such word as Priest should be used for those officers, and not Minister, which signifies at large every one that ministers in that holy office, of what Order soever he be." The word "Minister" had formerly been used as identical with "Priest," as may be seen by the 32nd Canon, which forbids Bishops to "make any person, of what qualities or gifts soever, a Deacon and a Minister both together in one day." This distinctive meaning had now passed away, and "Ministers" was colloquially the name for Dissenting preachers, and for Clergymen of every Order. By the insertion of the new word, therefore, the whole Rubric was intended to enjoin, not only that the congregation are not to repeat the Absolution, as they have repeated the Confession, but also that it must not be said by a Deacon. If a Deacon says Morning or Evening Prayer, in the presence of a Priest, the latter should say the Absolution, and if no Priest is present, the Deacon should make a pause, to give opportunity for the offering up of a short secret prayer by himself and the congregation, and then pass on to the Lord's Prayer.

The Absolution was composed by the Revisers of 1552, evidently with the old form of Absolution, which was used in the Prime and Compline Services, before them. There is also some similarity between the opening words and those of a Prayer which was placed at the end of the Litany in the Primer of 1535; and which again, from the prayer, "forgive us now while we have time and space," seems to have been founded on the ancient Absolution, with its "*spatium veræ penitentia*," though the first part is identical with a Lenten Collect of St. Gregory's Sacramentary.

Some phrases, a good deal like those of our Absolution, are also found in the form of prayer got up by John à Lasco, or Laski, a Polish refugee, for the German congregation which he was allowed to gather together at Austin-friars in London; but the

likeness is not such as to make it probable that the English form was derived from his Latin one, though it does rather indicate that both were in part derived from some such originals as those printed in the text above.

Two questions have been raised with respect to this form of Absolution. First, whether those who composed it, and placed it where it is, intended it for an Absolution of penitent sinners, or merely for a declaration of God's mercy. Secondly, whether, irrespective of their intention, it is so constructed as to be effective for the remission of sins.

(1) The first question is all but decided by the title. Here, in the Communion Service, and in the Prayers to be used at Sea, the same word, "Absolution," is used for designating two different forms; and in the Visitation of the Sick, the third form in use by the Church of England is spoken of in the direction "the Priest shall absolve him." It seems beyond all probability that this designation could have been used of all three forms without any verbal distinction, and yet that a real difference of meaning lay hidden under the use of it, and that to such an extent as to make it in one place contradictory of itself in another place. What the word "Absolution" in the rubrical title so far proves, is confirmed by the addition made to it at the Hampton Court Conference of 1604, when it was altered to the "Absolution, or remission of sins," clearly showing what opinion the Divines there assembled held respecting the intention with which the form was inserted fifty-one years before. It is still further confirmed by a note of Bishop Andrewes (one already quoted), in which, after saying that the Absolution is pronounced *authoritative*, he adds, "For authority of Absolution, see Ezek. xxxiii. 12. Job xxxiii. 23. Num. vi. 24. 2 Sam. xii. 13. John xx. 23." An examination of these passages of Scripture will show that Bishop Andrewes (one of the most learned theologians and Scriptural scholars that the Church of England has ever had) must certainly have supposed that this was intended for an actual Absolution; and that, in his opinion, it was such.

(2) The Absolution itself is constructed on a similar principle to that on which Collects are formed; and as the precatory part of a Collect is sometimes very short and condensed¹, so here the actual words of Absolution are only "He pardoneth and absolveth all them that truly repent, and unfeignedly believe His holy Gospel." The preceding portion is a statement of the antecedent reasons—God's mercy, and the delegation of His authority—for pronouncing Absolution; and what follows is an authoritative exhortation to follow up the words of temporary confession and absolution with prayer for perseverance and final pardon. The words which thus form the essence of the Absolution are of a declaratory kind, while those in the old Morning and Evening Services of the Church were precatory, as may be seen from the original Latin form printed above, and its English translation in the note below; but the change has rather strengthened than weakened the force of the form adopted. Nor must we be led

¹ See "Introduction to the Collects, Epistles, and Gospels."

Mark i. 14, 15.
Acts xx. 21.
Acts v. 31.
2 Cor. vii. 10.
Ezek. xxxvi. 26, 27.
Luke xi. 18.
Eccles. v. 1, 2.
Ps. xix. 14.
2 Cor. vii. 21.
1 Pet. i. 15. iv. 2, 3.
* Ps. xxxviii. 38.
Matt. xxv. 34, 46.
Rev. xxii. 12, 14.

truly repent, and unfeignedly believe his holy Gospel. Wherefore let us beseech him to grant us true repentance, and his holy Spirit, that those things may please him, which we do at this present, and that the rest of our life hereafter may be pure and holy, so that at the last we may come to his eternal joy, through Jesus Christ our Lord.

* Ps. cvi. 46.
Deut. xxvii. 15.
Rev. xix. 4.

¶ *The people shall answer here, and at the end of all other prayers, Amen.*

Acts xx. 36.
2 Chron. vi. 13.
xxi. 5.
Luke xxii. 4.

¶ *Then the Minister shall kneel, and say the Lords Prayer with an audible voice; the People also kneeling, and repeating it with him, both here, and wheresoever else it is used in Divine Service.*

Matt. vi. 9, 13.

OUR Father, which art in Heaven, Hallowed be thy Name. Thy

liberet vos ab omni malo; conservet et confirmet in bono; et ad vitam perducat æternam. Amen.

Absolutionem et remissionem omnium peccatorum vestrorum, spatium veræ penitentia, emendationem vitæ, gratiam et consolationem Sancti Spiritus, tribuat vobis omnipotens et misericors Dominus. Amen.]

Ad Matutinas . . . dicat sacerdos Pater Noster Salisbury Use. et Ave Maria.

[ΠΑΤΕΡ ἡμῶν ὁ ἐν τοῖς οὐρανοῖς, Ματθ. vi. 9, 13. ἀγιασθήτω τὸ ὄνομά σου. Ἐλθέτω ἡ

away by the word "declaratory," so often used to distinguish this from the other two forms of Absolution used in the Prayer Book; for to "declare" God's pardon of sinners is to give effect to that pardon, as when the authorized subordinate of an earthly sovereign declares pardon in that sovereign's name. This form is, in fact, closely analogous to the formulary of Baptism used in the Eastern Church,—“The servant of God (N.) is baptized in the Name of the Father, Amen, and of the Son, Amen, and of the Holy Ghost, Amen.” And as these words are undoubtedly sufficient for fulfilling our Lord's words, “Baptizing them in the name of the Father, and of the Son, and of the Holy Ghost,” so are the absolving words of our Absolution sufficient to fulfil His other words, “Whose soever sins ye remit, they are remitted unto them.”

The special form in which the Absolution is moulded was probably adopted from a careful consideration of the use which was to be made of it. It is an Absolution uttered over a mixed congregation, and yet it can only be efficacious towards those who have honestly said the Confession as it is intended to be said. The conditions of pardon are therefore distinctly expressed, that the impenitent may not be misled, and take to themselves a forgiveness to which they have no claim. And as it is a public Absolution, “He pardoneth and absolveth” is adopted in analogy with the “*tribuat vobis omnipotens et misericors Dominus*,” rather than the positive form, “by His authority I absolve,” as used in absolving individual penitents¹.

The effect of this Absolution in the daily services of the Church is (1) to reconcile the Church, as a community, daily to her God, through the mercies of Christ; (2) to prepare each person present for the work of offering praise to Him; (3) to convey pardon of

¹ The ancient form of Confession, *Miscreatur*, and Absolution, was as follows, being used in the midst of the preces at Prime and Compline.

The Priest, looking towards the Altar,

I confess to God, the Blessed Mary, and all the Saints [turning to the choir], and to you, that I have sinned exceedingly in thought, word, and deed, of my own fault [looking back to the Altar]. I beseech Holy Mary, all the Saints of God, and [looking back to the Choir] ye to pray for me.

The Choir replies, turning to the Priest,

Almighty God have mercy upon you, and forgive you all your sins, deliver you from all evil, preserve and strengthen you in all goodness, and bring you to everlasting life. Amen.

Then the Choir, turning to the Altar,

I confess to God . . . to pray for me.

Then let the Priest say to the Choir, in the first person, if necessary,

Almighty God have mercy upon you . . . everlasting life. Amen.

The Almighty and merciful Lord grant you Absolution and Remission of all your sins, space for true repentance, amendment of life, and the grace and consolation of the Holy Spirit. Amen.

sin to an extent correlative with the extent of penitence in those over whom it is uttered. As was said in the case of the general Confession, that it does not supersede a particular confession; so it must be remembered that the general Absolution does not supersede a particular one. But the necessity for absolution is so great, that the Church has provided against any one being without it by this daily utterance of it, in which it is cast abroad as the Sower sowed his seed, or as God sends His rain upon the just and the unjust. It is a ministration in close analogy with the continual superabundance of the mercies of God in Christ, which flow down even to the skirts of our High Priest's clothing. According to the words, “freely ye have received, freely give,” the Church casts her bread upon the waters in faith, believing that God's word of absolution will not return unto Him void. And for its efficiency, in the words of a recent writer, “all that is needed is that there be fit, i. e. truly repentant recipients of it; that secured, wheresoever it touches, it blesses and heals¹.”

The people shall answer] The words “here and at the end of all other prayers” were added by Bishop Cosin. He also wished to make a marked separation between the portion of the service ending with the Absolution, and that beginning with the Lord's Prayer. After the “Amen” to the former he wrote, “Place here a fleuron,” and at the head of the Lord's Prayer, over leaf, he has made a note, “Set here a faire compartment (ornamental page-heading) before this title.” And although he has not erased the previous title before the Sentences, he has here repeated it,—“An Order for Morning Prayer.” He probably contemplated the occasional use of a short service, from which all before the Lord's Prayer was to be omitted. In the first series of his notes on the Prayer Book (Works, v. 47), Bishop Cosin has also written on the Lord's Prayer, “Here begins the service; for that which goes before is but a preparation to it, and is newly added in King Edward's Second Book, in imitation of the Liturgy and Mass of the Church of Rome. But as their hours begin with the Lord's Prayer, so begins our mattins, and the high service of the altar. And they begin as they should do, for this was the ancient custom of the Christians, when they were met together to pray; they said that prayer for a foundation and a beginning of all the rest, which Christ Himself had taught them.” [Cf. Works ii. 9.]

THE LORD'S PRAYER.

Then the Minister] From 1552 to 1661, the Rubric stood, “Then shall the Minister begin the Lord's Prayer with a loud voice.” Before 1552, it had been “The Priest being in the

¹ Principles of Divine Service, i. 317.

Kingdom come. Thy will be done in Earth, As it is in Heaven. Give us this day our daily bread. And forgive us our trespasses, As we forgive them, that trespass against us. And lead us not into temptation; But deliver us from evil: For thine is the Kingdom¹, the Power, and the Glory, For ever and ever. Amen.

The Irish MS. reads, "And the power," but *and* is erased in the sealed copies.

¶ *Then likewise he shall say,*

Ps. li. 15.

O Lord, open thou our lips.

Answer.

Ps. xxii. 19.

And our mouth shall shew forth thy praise.

Priest.

Ps. lxx. 1.

O God, make speed to save us.

Answer.

Ps. xxxviii. 22.

O Lord, make haste to help us.

Βασιλεία σου γενηθήτω τὸ θέλημά σου, ὡς ἐν οὐρανῷ καὶ ἐπὶ τῆς γῆς. Τὸν ἄρτον ἡμῶν τὸν ἐπιούσιον δὸς ἡμῖν σήμερον. Καὶ ἄφες ἡμῖν τὰ ὀφειλήματα ἡμῶν, ὡς καὶ ἡμεῖς ἀφίεμεν τοῖς ὀφειλέταις ἡμῶν. Καὶ μὴ εἰσενέγκῃς ἡμᾶς εἰς πειρασμόν· ἀλλὰ ῥύσαι ἡμᾶς ἀπὸ τοῦ πονηροῦ. Ὅτι σου ἐστὶν ἡ βασιλεία, καὶ ἡ δύναμις, καὶ ἡ δόξα εἰς τοὺς αἰῶνας. Ἀμήν.]

Postea sacerdos incipiat servitium hoc modo: Salisbury Use.

Domine, labia mea aperies.

Chorus respondeat. Et os meum annuntiabit laudem tuam.

Sacerdos statim. Deus in adiutorium meum intende.

R. Domine, ad adjuvandum me festina.

quire, shall begin with a loud voice the Lord's Prayer, called the *Paternoster*." It was altered to its present form by Bishop Cosin. The mattins began here in the Prayer Book of 1549; and before that time, the Lord's Prayer was said secretly by the Priest, the public part of the service beginning with the "*Domine, labia mea aperies*," as is shown in the Latin Rubric printed before that versicle.

with him] That is, simultaneously, clause by clause.

wheresoever it is used in Divine Service] Bishop Cosin overlooked the Rubric immediately before the Lord's Prayer in the Communion Service, which directs the priest to say it, without any direction as to the people. It is not likely that there was any intention of overriding that Rubric by this.

The Doxology was added here in 1661, but not by Bishop Cosin, who wrote among some "Directions to be given to the printer," "Never print the Lord's Prayer beyond—deliver us from evil. Amen." The Doxology is supposed not to have been in the original of St. Matthew, as it is not in St. Luke. In the ancient Liturgies of the East, after "deliver us from evil" (said, with the rest of the prayer, by the people), the priest offers a prayer against the evil and the Evil One, called the Embolismus; and the Doxology is then sung by the people. Probably this is a primitive usage; and the antiphon so sung has crept into the text of the Gospel.

The paraphrase of Bishop Andrewes, in his note on the Lord's Prayer here, is very concise and instructive.

Our Father. Et si læsus est, Pater est.

Which art in Heaven. Eminenter, non inclusive.

Hallowed be Thy Name. In me, per me, super me.

Thy Kingdom come. Ut destruaturs regnum peccati, per quod regnavit mors et diabolus.

In earth. In me, qui sum terra.

In heaven. A sanctis angelis.

Give us this day our daily. Pro necessitate.

Bread. Proprium, licite acquisitum, supercœlestem et corporum.

Forgive us our trespasses. Talenta dimitte.

Lead us not. Nec sinas intrare ductos pronosque.

From evil. Ab autore mali { extra { diabolo. mundo.

A malo { intra, nobismetipsis. culpæ per gratiam. pœnæ per misericordiam. omni per pacem.

Its fitness for use in the manner here directed by the Church is also beautifully brought out by Sir Richard Baker. "Though this prayer is the supplication of the whole body of the Church, and of every member thereof; yet each petition seems to have

some special relation to some peculiar member. For the first petition may not unfitly be thought the prayer of angels; the second, the prayer of the saints departed; the third, the prayer of the faithful living; the fourth, the prayer of all creatures; the fifth, the prayer of penitent sinners; the sixth, the prayer of infants."

The various modes in which saints have used this Divine prayer with a special intention, are almost infinite; and it would be well for every one to follow their example, by having such a special intention in view whenever it is said in the Services of the Sanctuary. In this place, at any rate, it should be offered up as the complement and crown of the Absolution and Confession, on the one hand; and laid hold of, on the other hand, as a mediatorial key, by which the door of heaven is to be opened for the ascent of the Church's praises to the Throne of God. It is a prayer, says the old "*Mirrore*," that said in the Unity of the Church, is never unsped.

Some ancient English versions of the Lord's Prayer will be found in the notes to Evening Prayer; where also will be found an exposition and a paraphrase; the one, an ancient one, illustrating the general meaning of the Lord's Prayer; the other, modern, drawing out its fulness as a prayer for the Unity of the Church, according to the method of special intention above suggested.

THE VERSICLES.

O Lord, open Thou] These versicles and responses have been used time immemorial as the opening of the daily service of praise which the Church continually offers to God. They are mentioned in the rule of St. Benedict (the great founder of the Benedictine order, which guarded and expressed the devotional system of the Church for so many ages, and who died in A.D. 543), as the prefatory part of the service; and he probably adopted them from the previous custom of the Church; the two Psalms from which they are taken having been used at the beginning of the daily Offices in the East from the earliest ages. Taken from such a source, with only the change from the singular to the plural number in the pronouns¹, they form a most fitting prefix

¹ This change of pronouns was made in 1552. A reason for retaining the singular is given in an old exposition of the services. "And take heed that all this verse, both that part that is said of one alone, and that that is answered of all together, are said in the singular number; as when ye say 'mine,' or 'me,' and not 'our,' or 'us,' in token that ye begin your praising and prayer in the person of holy Church, which is one, and not many. For though there be many members of holy Church, as there are many Christian men and women, yet they make one body, that is holy Church, whereof Christ is the Head." *Mirror* xli. The same commentary explains, that "O Lord, open thou my lips," and its response, were used only at Mattins, because all the day after the lips should remain ready for God's praises. ["The *Mirrore* of our Lady" is a commentary on the daily Services, written for the Nuns of Sion, and printed in 1530.]

¶ Here all standing up, the Priest shall say,

Matt. xxviii. 19. Glory be to the Father, and to the
Isa. vi. 3. Son : and to the Holy Ghost ;
Rev. iv. 8.

Answer.

Job xxxviii. 7. As it was in the beginning, is now,
Ps. cxlv. 4. and ever shall be : world without end.
civ. 31. Amen.

Priest.

Ps. cl. 6. Praise ye the Lord.
Rev. xix. 1. 6.

Answer.

Ps. cxliii. 3. The Lord's Name be praised.
Rev. v. 11. 13.

2 Chron. xx. 19. ¶ Then shall be said, or sung this Psalm follow-
1 Chron. xvi. 9. ing : Except on Easter-Day, upon which
Eph. v. 19. another Anthem is appointed ; and on the
Rev. xv. 3. Nineteenth day of every month it is not to
be read here, but in the ordinary course of
the Psalms.

Venite, exultemus Domino. Ps. 95. **O** COME, let us sing unto the
Lord : let us heartily rejoice in
the strength of our salvation.

Let us come before his presence with
thanksgiving : and shew our selves glad
in him with Psalms.

Gloria Patri, et Filio, et Spiritui Sancto. Salisbury Use.

Sicut erat in principio, et nunc, et
semper, et in sæcula sæculorum.
Amen.

Alleluia [vel Laus Tibi, Domine,
Rex æternæ gloriæ].

Sequatur invitatorium hoc modo. Psalmum

Venite

[Invitatory entire.]

VENITE, exultemus Domino, jubi- [The version is
lemus Deo salutari nostro : præoc- that of the Old
cupemus faciem ejus in confessione, et Italic.]
in psalmis jubilemus ei.

to the Psalmody which is so integral a portion of Divine Service. Except the Lord open our lips, we cannot show forth His praise with the heart. They are the "Sursum Corda" of the Daily Service, and yet have a tone of humility and even penitence, given to them by their derivation from the fifty-first and seventieth Psalms. It is probably to express this penitential tone that the musical note to which the first of them is said by the Priest is always a low one, being depressed as much as a fifth from the pitch in which the Lord's Prayer has been recited : and also that we continue kneeling till the Gloria Patri. The second versicle is a paraphrase of the "Hosanna,"—Save, Lord, we beseech Thee,—with which our Lord was led in triumph to the Temple.

GLORIA PATRI.

The beautiful dogmatic anthem which is here used for the first time in the service is of primitive origin, and, if not an independently inspired form, is naturally traceable to the angelic hymns in Isaiah vi. 3, and Luke ii. 13, the Trinitarian form of it being equally traceable to that of the baptismal formula ordained by our Lord in Matt. xxviii. 19. Clement of Alexandria, who wrote before the end of the second century, refers to the use of this hymn under the form, *ἀινοῦντες τῷ μόνῳ πατρὶ καὶ υἱῷ καὶ τῷ ἁγίῳ πνεύματι*, "giving glory to the one Father, and to the Son, and to the Holy Ghost," and a hymn of about the same date is printed by Dr. Routh, in which there is an evident trace of the same custom : *ἠνοῦμεν πατέρα καὶ υἱόν, καὶ ἅγιον πνεῦμα Θεοῦ*, "Praise we the Father and Son, and Holy Spirit of God." It is also referred to even earlier by Justin Martyr. The Arian heretics made a great point of using Church phraseology in their own novel and heretical sense ; and they adopted the custom of singing their hymn in the form, "Glory be to the Father, by the Son, and in the Holy Ghost," which evaded the recognition of each Person as God. It thus became necessary for the Church to adopt a form less capable of perversion ; and in ancient liturgies it is found as it is still used in the Eastern Church, "Glory be to the Father, and to the Son, and to the Holy Ghost, now and ever, world without end." In the Western Church, the second part, "As it was in the beginning, is now, and ever shall be, world without end," has been used for nearly as long a period, being found ordered in the fifth Canon of the Council of Vaison, presided over by Cæsarius of Arles, in A.D. 529. The use of the hymn in this place, after the *Domine ad adjuvandum*, is also recognized by the rule of St. Benedict a few years further on in the sixth century ; and it is

found so placed in the earliest English services, those which are usually called "Anglo-Saxon." It also occurs in the same position in the daily offices of the Eastern and the Roman Churches at the present day : so that the Church throughout the world opens its lips day by day with the same words of faith in the Blessed Trinity, and of devout praise to each Person ; worshipping one God in Trinity, and Trinity in Unity. The addition of the succeeding versicle and response gives to this unity of praise on earth a further likeness to the unity of praise which was revealed to St. John : "And a voice came out of the throne, saying, Praise our God, all ye His servants, and ye that fear Him, both small and great. And I heard as it were the voice of a great multitude, and as the voice of many waters, and as the voice of mighty thunders, saying, Alleluia ; for the Lord God omnipotent reigneth" (Rev. xix. 6).

In the Prayer Book of 1549 the old usage of saying the "Hallelujah" from Easter to Trinity Sunday in this place was continued. It was expunged altogether in 1552 ; restored in the English form, "Praise ye the Lord," and for constant use, in the Elizabethan revision. The response to it, "The Lord's Name be praised," is first found in the Scottish Prayer Book of 1637, and was inserted here in 1661. The latter represents in an unvarying form the variable invitatories which used to precede the *Venite* in the old Latin services.

There are two old customs still kept up with respect to the *Gloria Patri*. The one is that of turning to the East, as in the recitation of a Creed, whenever it is said or sung in Divine Service ; an usage enjoined in the ancient Psalter of the Church of England, and still observed, e. g. at Manchester Cathedral. The other custom is a more general one, that of reverently inclining the head during the first half of the hymn, as a humble gesture recognizing the Divine glory of each of the Three Persons, and in imitation of the gesture of the angels, who veil their faces with their wings when singing to the glory of the Trinity in the vision of Isaiah. An old Canon of the Church of England enjoins : "Quotiesque dicitur Gloria Patri et Filio et Spiritui Sancto, ad eadem verba Deo humiliter se inclinent." Wilkins' Conc. iii. 20. And in the "Mirroure," there is the direction, "Ye incline at Gloria Patri."

Bishop Cosin wished to revive the use of Invitatories on Sundays, having inserted this Rubric in the Prayer Book which was laid before the Revisers of 1661, immediately after "Praise ye the Lord : " "And upon any Sunday, or Lord's Day, this com-

Mal. i 14. For the Lord is a great God : and a great King above all gods.
 Al. hands. In his hand are all the corners of the earth : and the strength of the hills is his also.

The sea is his, and he made it : and his hands prepared the dry land.

See Exhort. and Gen. Conf.

O come, let us worship, and fall down : and kneel before the Lord our Maker.

For he is the Lord our God : and we are the people of his pasture, and the sheep of his hand.

To day if ye will hear his voice, harden not your hearts : as in the provocation, and as in the day of temptation² in the Wilderness ;

When your Fathers tempted me : proved me, and saw my works.

[Invitatory entire.]

Quoniam Deus magnus Dominus, et Rex magnus super omnes deos : quoniam non repellet Dominus plebem suam, quia in manu ejus sunt omnes fines terræ, et altitudines montium ipse conspicit.

quoniam—suam, not in Vulg.
 mont. ipsius sunt. Vulg.

[Invitatory, latter half.]

Quoniam ipsius est mare, et ipse fecit illud ; et aridam fundaverunt manus ejus : venite, adoremus et pro- cidamus ante Deum, ploremus coram Domino qui fecit nos ; Quia ipse est Dominus Deus noster, nos autem popu- lus ejus, et oves pascuæ ejus.

siccam manus ejus formaverunt. Vulg.
 Vulg. as Eng.

[Invitatory entire.]

Hodie, si vocem ejus audieritis, nolite obdurare corda vestra, sicut in exacer- batione, secundum diem tentationis in deserto : ubi tentaverunt me patres vestri, probaverunt, et viderunt opera mea.

irritatione. Vulg.

memoration of His rising from the dead shall be said or sung. Priest, Christ is risen againe, &c. And upon the feast of Easter, Christ, our Passover, is offered up for us. Therefore, let us keep the feast, &c., *ut in die Pasch.* Then shall be said or sung," the *Venite* as we now have it.

Then shall be said or sung] This Rubric, as altered by Bishop Cosin, has great historical value, for the illustration that it gives of the mode in which the Psalms were intended to be said or sung. It is as follows : "Then shall be said or sung this Psalm following (except on Easter Day, when another Anthem is appointed), one verse by the priest, and another by the people ; and the same order shall be observed in all psalmes and hymns throughout this Book. But in colledges, and where there is a Quire, the same shall be sung by sides, as hath bin accustomed." In the third series of his notes on the Prayer Book, there are also these remarks on the response, "And our mouth shall shew forth Thy praise :—" "This is the answer of all the people. In the second book of Edward VI. the word 'Choir' is every where put for our word 'Answer ;' and by making this answer, they promise for themselves that they will not sit still to hear the psalms and hymns read only to them, as matter of their instruction ; but that they will bear a part in them with the priest, and keep up the old custom still of singing, and answering verse by verse, as being specially appointed for the setting forth of God's praise ; whereunto they are presently invited again by the minister, in these words, 'Praise ye the Lord.' So that our manner of singing by sides, or all together, or in several parts, or in the people's answering the priest in repeating the psalms and hymns, is here grounded ; but if the minister say all alone, in vain was it for God's people to promise God, and to say, that their mouth also should shew forth His praise." [Works, v. 445.]

VENITE EXULTEMUS.

This Psalm has been used from time immemorial as an introduction to the praises of Divine Service ; and was probably adopted by the Church from the services of the Temple¹. It was perhaps such a familiar use of it in both the Jewish and the Christian system of Divine Service, which led to the exposition of it given in the third chapter of the Epistle to the Hebrews,

¹ In the Eastern Church an epitome of the first three verses is used, but in the Latin and English Churches it has always been used entire.

where the Apostle is showing the connexion between the two dispensations, and the way in which all belief and worship centres in our Divine High Priest and perpetual Sacrifice.

In one of St. Augustine's sermons he plainly refers thus to the ritual use of the *Venite* : "This we have gathered from the Apostolic lesson. Then we chanted the Psalm, exhorting one another, with one voice, with one heart, saying, 'O come, let us adore, and fall down before Him, and weep before the Lord who made us.' In the same Psalm too, 'Let us prevent His face with confession, and make a joyful noise unto Him with psalms.' After these the lesson of the Gospel showed us the ten lepers cleansed, and one of them, a stranger, giving thanks to his cleanser" (St. Aug. Serm. Ben. ed. 176, Oxf. trans. 126). Durandus, in his Rationale of Divine Offices, says that this psalm was sung at the beginning of the service to call the congregation out of the church-yard into the church ; and that it was hence called the Invitatory Psalm ; but probably this was a local or temporary use of it, and does not represent the true spirit of its introduction into the Morning Service. It is far more likely that its comprehensive character, as an adoration of Christ, was that which moved the Divine Instinct wherewith the Church is endowed to place this psalm in the forefront of her Service of Praise.

Until the translation of our Offices into English it was the custom to sing the *Venite* in a different manner from that now used ; with the addition, that is, of Invitatories. These were short sentences (varied according to the ecclesiastical season) which were sung before the first verse, after each of the five verses into which it was then divided, and also after the Gloria Patri at the end. Thus in Trinity Season, "*Laudemus Jesum Christum ; quia Ipse est Redemptor omnium sæculorum,*" would be sung before and after the first, and also after the third and fifth of the divisions indicated in the Latin version above. After the second, fourth, and Gloria Patri, would be sung "*Quia Ipse est Redemptor omnium sæculorum*" only ; and at the conclusion the whole of the Response, as at the beginning. These Invitatories were altogether set aside, as regards the *Venite*, in 1549 ; and, as has been already shown, the "Sentences" were substituted for them at the commencement of Divine Service in 1552. Thus reduced to its psalter simplicity, the *Venite Exultemus* is used before the Psalms every morning, except upon Easter Day, when a special Invitatory Anthem is substituted, which is printed

Forty years long was I grieved with this generation, and said : It is a people that do err in their hearts, for they have not known my ways.

Heb. iv. 3.

Unto whom I swear in my wrath : that they should not enter into my rest.

Glory be to the Father, and to the Son : and to the Holy Ghost ;

As it was in the beginning, is now, and ever shall be : world without end. Amen.

¶ *Then shall follow the Psalms in order as they be appointed. And at the end of every Psalm throughout the Year, and likewise in the end of Benedicite, Benedictus, Magnificat, and Nunc dimittis, shall be repeated,*

Glory be to the Father, and to the Son : and to the Holy Ghost ;

Answer.

As it was in the beginning, is now, and ever shall be : world without end. Amen.

¶ *Then shall be read distinctly with an audible voice the First Lesson, taken out of the Old Testament, as is appointed in the Kalendar, (except there be proper Lessons assigned for that day :) He that readeth so standing and turning himself, as he may best be heard of all such as are present. And after that, shall be said or sung, in English, the Hymn called Te Deum Laudamus, daily throughout the Year.*

¶ *Note, That before every Lesson the Minister shall say, Here beginneth such a Chapter, or Verse of such a Chapter, of such a Book : And after every Lesson, Here endeth the First, or the Second Lesson.*

before the Collect for the day. On the nineteenth day of every month, it is sung in its place as one of the Mattins psalms, so as not to be twice used at the same service, which is a continuation of the old English usage.

An old custom lingers (especially in the North of England) of making a gesture of reverence at the words, "O come, let us worship and fall down;" which is a relic of the custom of actual prostration as it was once made in many churches at these words.

The Rubrics between the Venite and the Te Deum were all rearranged in 1661 ; and the new arrangement, as we now have it, appears in MS., in Bishop Cosin's Prayer Book. The only changes of importance were these. (1) "He that readeth," and "He shall say," were substituted for "the minister that readeth," and "the minister shall say," in the direction about the Lessons. (2) This Rubric of the preceding books was erased, "And to the end the people may the better hear in such places where they do sing, there shall the lessons be sung in a plain tune, after the manner of distinct reading, and likewise the epistle and gospel."

THE PSALMS.

For notes relating to the ritual use of the Psalms, the reader is referred to the Introduction to the Psalter.

After the Psalms have been sung it is customary in many churches to play a short voluntary on the organ : this is mentioned by Archbishop Secker as having "long been customary"

[*Invitatory, latter half.*]

Quadragesima annis proximus fui *offensus*. Vulg. generationi huic, et dixi, Semper hi errant corde : ipsi vero non cognoverunt vias meas : quibus juravi in ira *Ut* juravi. Vulg. mea, Si introibunt in requiem meam.

[*Invitatory entire.*]

Gloria Patri, et Filio, et Spiritui Sancto.

Sicut erat in principio, et nunc, et semper, et in sæcula sæculorum. Amen.

[*Invitatory, (1) latter half, (2) entire.*]

[*And all the Clerks who have sung the Psalms standing up, turning to the Altar, shall each of them say the Gloria, in his station, which shall be observed throughout the whole year.*]

Transl. of Sarum Psalter, p. 34.

Clericus primam lectionem legat hoc modo. Salisbury Use. Lectio prima. Esaiæ i. Visio Esaiæ filii Amos, (Advent Sunday &c. &c.) e. g.)

[*The Chapter is said in the midst of the Choir by the Priest, without changing his place or vestment, but turned to the Altar, not chanting, but reading as in the tone of a reader . . .*]

Transl. of Sarum Psalter, p. 323.

in his day ; and in a letter from Oxford in No. 630 of the "Spectator." Perhaps it may be accounted for by a Salis-bury Rubric between the Psalms and Lessons, "*Deinde dicitur Paternoster et Credo in Deum a toto choro privatim.*" So at Durham a voluntary has also been substituted for the "Agnus Dei," which was once sung during the Communion of the Laity.

THE LESSONS.

For notes relating to the ritual use of Lessons in Divine Service, the reader is referred to a note on "The Order how the rest of Holy Scripture is appointed to be read," in the Calendar.

THE CANTICLES.

The ritual use of Holy Scripture in Divine Service has always been connected with praise and thanksgiving. The short responds which were intermingled with the Lessons in the pre-Reformation Services were very ancient in their origin, although, no doubt, they had increased in number during the development of the Services for monastic use. Of a like antiquity is the "Glory be to Thee, O Lord" before, and the "Thanks be to Thee, O Lord" after the reading of the Gospel in the Communion Service. As will be seen in the account given of the Te Deum, the use of responsory hymns after the Lessons is also very ancient ; and it probably arose out of the pious instinct which thus connected the idea of thanksgiving with the hearing of God's revelations to man. The Council of Laodicea (A.D. 367) ordered, in its seven-

Te Deum Laudamus.
Psalms passim.
Rev. xix. 5.
Baruch iii. 6.
Judith ix. 14.
Isa. lxvi. 23.
Rev. xiv. 6.
xv. 4.

John iv. 23.
Rev. v. 11, 13.
Prayer of Manasses.

Isa. vi. 2.
Ezek. i. 4. x. 15.
19.

Isa. vi. 3.

Col. i. 20.

Rev. iv. 10.

Rev. xviii. 20.
xix. 1.

WE praise thee, O God : we acknowledge thee to be the Lord.

All the earth doth worship thee : the Father everlasting.

To thee all Angels cry aloud : the Heavens, and all the Powers therein.

To thee Cherubin, and Seraphin : continually do cry.

Holy, Holy, Holy : Lord God of Sabaoth ;

Heaven and earth are full of the Majesty : of thy glory.

The glorious company of the Apostles : praise thee.

The goodly fellowship of the Prophets : praise thee.

TE Deum laudamus : te Dominum confitemur.

Salisbury Use.
Cf. Antiphon to Athan. Creed.
"Te Deum Patrem confitemur."

Te æternum Patrem : omnis terra veneratur.

Tibi omnes Angeli : tibi cœli et universæ potestates.

Tibi Cherubin et Seraphin : incessabili voce proclamant,

Cherubim et Seraphim. MSS.

Sanctus, Sanctus, Sanctus : Dominus Deus Sabaoth ;

Pleni sunt cœli et terra : majestatis gloriæ tuæ.

Te gloriosus Apostolorum chorus.

St. Cyprian, de Mortalitate.

Te Prophetarum laudabilis numerus,

teenth Canon, that Psalms and Lessons should be used alternately ; and this Canon doubtless refers to a custom similar to ours.

A leading principle of all the Canticles appears to be that of connecting the written with the personal Word of God ; and that as much in respect to the Old Testament Lessons as to those taken out of the Gospel or other parts of the New Testament. This is more especially true of those Canticles which are placed first of the two in each case, the Te Deum, the Benedictus, the Magnificat, and the Nunc Dimittis. The three latter of these were inspired hymns spoken at the time when the Eternal Word was in the act of taking our nature to redeem and glorify it ; and the first is, if not inspired, the most wonderful expression of praise for the abiding Incarnation of our Lord that uninspired lips have ever uttered. It may also be observed that the Canticles are set where they are, not that they may apply to any particular chapters of the Holy Bible, though they often do so in a striking manner, but with reference to Divine revelation as a whole, given to mankind by God in His mercy and love, and therefore a matter for deepest thankfulness, and most exalted praise.

The three New Testament Canticles are all taken from the Gospel of St. Luke ; the sacrificial and sacerdotal gospel, the symbol of which is the "living creature like unto a calf" or "an ox ;" and in which is chiefly set forth our Blessed Lord's relation to the Church as her High Priest offering Himself for sin, and originating from His own Person all subordinate ministrations of grace.

TE DEUM LAUDAMUS.

This most venerable hymn has been sung by the whole Western Church "day by day" on all her feasts from time immemorial. It is found in our own Morning Service as far back as the Conquest ; and its insertion in the Salisbury Portiforium by St. Osmund was doubtless a continuation of the old custom of the Church of England.

Very ancient ecclesiastical traditions represent the *Te Deum* as a hymn antiphonal extemporized by St. Ambrose and St. Augustine at the baptism of the latter, A.D. 386. The written authority for this tradition is traceable to an alleged work of St. Datius, a successor of St. Ambrose in the See of Milan, A.D. 552. But this work has been proved by Menard, Muratori, and Mabillon, to be of much later date. There is also a Psalter in the Vienna Library, which was given by the Emperor Charlemagne to Pope Adrian I., A.D. 772, in the Appendix of which the *Te Deum* is found with the title "Hymnus quem Sanctus Ambrosius et Sanctus Augustinus invicem condiderunt : " and a similar title is found in other ancient copies. The title anciently given to it in the Psalter of our own Church was, "Canticum

Ambrosii et Augustini," and in 1661 Bishop Cosin wished so far to restore this title as to call it "The Hymn of St. Ambrose ;" but the ancient rubrical title was as it is at present. In the earliest mention that we have of it (i.e., in the rule of St. Benedict, framed in the beginning of the sixth century), it has the same title as in our present Prayer Book, the words of St. Benedict being "Post quartum Responsorium incipit Abbas *Te Deum Laudamus*, quo prædicto legat Abbas lectionem de Evangelio . . ." It is also named in the rule of St. Cæsarius of Arles about the same date ; being ordered to be sung at Mattins every Sunday in both systems. There is no reason to think that it was then new to the Church ; but we may rather conclude that it was a well-known hymn which the great founder of the Benedictines adopted for the use of his order from the ordinary use of the Church at large.

But the authorship of this divine hymn has been assigned to several saints both by ancient and modern authors, the earliest being St. Hilary of Poitiers, A.D. 355, and the latest, Nicetius, Bishop of Treves, A.D. 535. Some ancient copies, in the Vatican and elsewhere, give it the titles of *Hymnus S. Avundii*, and *Hymnus Sisebuti monachi*. It has also been attributed to St. Hilary of Arles, and to a monk of Lerins, whose name is not known, the number of persons named showing how much uncertainty has always surrounded the matter. It is scarcely possible that so remarkable a hymn should have originated in so remarkable a manner as that first referred to, without some trace of it being found in the works of St. Ambrose or St. Augustine, especially the Confessions of the latter¹. It may be that their names were connected with it because the one introduced it into the Church of Milan, and the other (taught by St. Ambrose) into the Churches of Africa.

For there is reason to think that the *Te Deum Laudamus* is much older than the time of St. Ambrose. So early as A.D. 252 we find the following words in St. Cyprian's Treatise "On the Mortality" that was then afflicting Carthage : "Ah, perfect and perpetual bliss ! There is the glorious company of the Apostles ; there is the fellowship of the prophets exulting ; there is the innumerable multitude of martyrs, crowned after their victory of strife and passion ;" and the striking parallel between them and the seventh, eighth, and ninth verses of the *Te Deum* seems

¹ In the latter we do indeed read . . . "we were baptized, and anxiety for our past life vanished from us. Nor was I sated in those days with the wondrous sweetness of considering the depth of Thy counsels concerning the salvation of mankind. How did I weep, in Thy Hymns and Canticles, touched to the quick by the voices of Thy sweet-attuned Church !" (St. Aug., Conf. IX. vi., p. 166, Oxf. Trans.) But this passage seems rather to indicate the use of Canticles already well known than the invention of any new one.

Rev. vii. 15. The noble army of Martyrs : praise thee.

Eph. iii. 10. 21. The holy Church throughout all the world : doth acknowledge thee ;

Ps. cxlv. 5. The Father : of an infinite Majesty ;
Heb. i. 3.
Jude 25.

Ps. cxliii. 3. Thine honourable, true : and only Son ;
John iii. 16.

John xiv. 26. Also the Holy Ghost : the Comforter.

Ps. xxiv. 8. Thou art the King of Glory : O Christ.
Rev. xix. 16.

Heb. i. 8. Thou art the everlasting Son : of the Father.
John i. 1. 18.

Luke i. 31. When thou tookest upon thee to deliver man : thou didst not abhor the Virgin's womb.
Matt. i. 18.

Te Martyrum candidatus, laudat exercitus.

Te per orbem terrarum : sancta confitetur ecclesia.

Patrem immensæ majestatis ;

Venerandum tuum verum : et unicum Filium ;

Sanctum quoque Paracletum Spiritum.

Tu rex gloriæ : Christe.

Tu Patris sempiternus es Filius.

Tu, ad liberandum, suscepturus hominem : non horruisti Virginis uterum.

Cf. Athan. Creed.
"Immensus
Pater," &c.

certainly more than accidental. There are several coincidences also between words in the Baptismal and other offices of the Eastern Church and particular verses of the Te Deum, and the former are supposed to be of extremely ancient date. In the Alexandrine MS. of the Scriptures, a work of the fourth or fifth century, preserved in the British Museum, there is moreover a Morning Hymn which is written at the end of the Psalter, and which is still used in the daily services of the Greek Church. The following is a translation:—

Glory to Thee, the giver of light.
Glory to God on high, and on earth peace, good will towards men.

We praise Thee, we bless Thee, we worship Thee, we glorify Thee, we give thanks to Thee for Thy great glory.

O Lord, heavenly King, God, Father Almighty: O Lord, only-begotten Son Jesus Christ, and Holy Spirit.

O Lord God, Lamb of God, Son of the Father, that takest away the sin of the world; have mercy upon us, Thou that takest away the sin of the world.

Accept our prayer: Thou that sittest at the right hand of the Father, have mercy upon us.

For Thou only art holy; Thou only Lord Jesus Christ art in the glory of God the Father. Amen.

Day by day I bless Thee, and praise Thy name for ever, and for ever and ever.

Vouchsafe, O Lord, to keep me this day without sin.

Blessed art Thou, O Lord God of our fathers; and praised and glorified be Thy name for ever. Amen.

Lord, let Thy mercy be upon us, as our trust is in Thee. *Ps. xxxiii. 22.*

Blessed art Thou, O Lord: O teach me Thy statutes. *Ps. cxix. 12.*

Lord, Thou hast been our refuge, from one generation to another. *Ps. xc. 1.*

I said, Lord, be merciful to me, heal my soul, for I have sinned against Thee. *Ps. xli. 4.*

Lord, I fly to Thee; teach me to do Thy will, for Thou art my God. *Ps. cxliii. 9, 10.*

For with Thee is the well of life; in Thy light shall we see light. *Ps. xxxvi. 9.*

Show forth Thy mercy to them that know Thee. *Ibid. 10.*

O Holy God, O holy Might, O holy Immortal, have mercy upon us. Amen.

The first division of this hymn is identical with the Eucharistic Gloria in Excelsis, and the last verse is the Trisagion of the

ancient Eastern Liturgies; the remaining portion has clearly a common origin with the Te Deum. Verses 8 and 9 are the same as the 24th and 26th verses of the latter. The 11th is also identical with the last of the Te Deum, but it is taken from Psalm xxxiii. 22. Like the Te Deum, this ancient Morning Hymn of the Greek Church borrows largely from the Psalms in its concluding portion, and the verses chosen are of a supplicatory character in both, though otherwise they do not correspond.

The most probable conclusion to arrive at is, that this noble canticle, in its present form, is a composition of the fourth or fifth century; and that it represents a still more ancient hymn, of which traces are to be found in St. Cyprian and the Morning Hymn of the Alexandrine Manuscript.

The Te Deum is only known as connected with the ritual of the Church. It seems also from the first to have been connected with the reading of the Morning Lessons, the expression "Keep us this day without sin," being some evidence of this, though not convincing, as an analogous form is used in "Give us this day our daily bread." In the Salisbury Use, which probably represents the more ancient use of the Church of England, it was directed to be sung after the last lesson on Sundays and other Festivals, except during Advent and the Lenten season from Septuagesima to Easter. Quignonez, in his reformed Roman Breviary, directed it to be used every day even in Lent and Advent. The Prayer Book of 1549 ordered it to be used every day, with the exceptions customary according to the older ritual; and as festivals were previously almost of daily occurrence, this was practically a continuance of the old rule. In 1552 the exceptions were erased, and have not since been restored; but as the alternative Canticle, Benedicite, remains, some ritualists conclude that it is to be used in Lent, as originally directed by the First Book of Edward VI., and not the Te Deum¹. Of ritual customs anciently con-

¹ This is not the ancient practice of the Church, it must be remembered. During Advent the following was sung instead of Te Deum on all Festivals when the latter would otherwise have been used. It is the last of nine Responds (Responsoria) used after the nine Lessons respectively.

"R. 9. Lætentur cæli, et exultet terra: jubilate montes laudem: quia Dominus noster veniet. Et pauperum suorum miserebitur.

¶ Orietur in diebus ejus justitia et abundantia pacis. Et pauperum suorum miserebitur.

Gloria Patri, et Filio, et Spiritui Sancto:

¶ Et pauperum suorum miserebitur."

The ancient ritual use of the Benedicite was entirely festive; though it was not indeed set aside from its place in Lauds during Lent and Advent.

Admirable substitutes for the Te Deum in Lent and Advent might be found in two other of the discontinued Lauds Canticles, the Song of Hezekiah (Isaiah xxxviii.) being exactly adapted for Lent, and that of

1 Pet. iii. 19.
Rom. viii. 29.

When thou hadst overcome the sharpness of death : thou didst open the Kingdom of Heaven to all believers.

Acts vii. 55.
John xvii. 5.

Thou sittest at the right hand of God : in the Glory of the Father.

Matt. xvi. 27.

We believe that thou shalt come : to be our Judge.

Acts iv. 29.
1 Pet. i. 19.

We therefore pray thee, help thy servants : whom thou hast redeemed with thy precious blood.

Eph. ii. 19.
Rev. vii. 4.
Wisdom v. 5.

Make them to be numbered with thy Saints : in glory everlasting.

O Lord, save thy people : and bless thine heritage.

[margin Psalm
xxviii. 9.]

Govern them : and lift them up for ever.

2 Chron. xxx. 21.

Day by day : we magnify thee.

Rev. v. 13. vii.
12. Heb. xiii. 21.

And we worship thy Name : ever world without end.

The Lord's
Prayer.

Vouchsafe, O Lord : to keep us this day without sin.

Tu devicto mortis aculeo : aperuisti credentibus regna cœlorum.

Tu ad dexteram Dei sedes : in gloria Patris.

Judex crederis esse venturus.

Te ergo quæsumus, famulis tuis subveni : quos pretioso sanguine redemisti.

Æterna fac cum sanctis tuis : gloria munerari.

Salvum fac populum tuum, Domine : et benedic hereditati tuæ.

Et rege eos, et extolle illos usque in æternum.

Per singulos dies, benedicimus te.

Et laudamus nomen tuum : in sæculum et in sæculum sæculi.

Dignare, Domine, die isto : sine peccato nos custodire.

modern reading,
"in gloria nume-
rari."

Vulgate, rege;
LXX, ποιμαίνων.

nected with the singing of this hymn, one still retains a strong hold upon English people, viz., that of bowing at the words "Holy, Holy, Holy," with the same reverent gesture that is used in the Creed : a custom derived from the angelic reverence spoken of in Isaiah in connexion with the same words. "And for because Angels praise God with great reverence, therefore ye incline when ye sing their song," says the Mirror.

Besides the use of the *Te Deum* in the Morning Service, there is a well-known custom of singing this triumphal hymn, by itself, arranged to elaborate music, as a special service of thanksgiving. It is directed to be used in this manner, in "Forms of Prayer to be used at Sea, after Victory, or deliverance from an Enemy : " and at the conclusion of coronations it is always so used, as it has been, time immemorial, over the whole of Europe. The Sovereigns of England have been accustomed to go in state to the singing of the *Te Deum* after great victories, and Handel's "Dettingen *Te Deum*" was composed for one of these occasions. Custom has also established this separate use of the *Te Deum* on other important occasions of thanksgiving.

The most ancient Christian music known has come down to us in connexion with this Canticle; being that known as the "Ambrosian *Te Deum*," which is found in a work on Music written by Boëthius, a Roman Consul, in A.D. 487. This is, however, thought to be an adaptation of the Temple psalmody of the Jews, like the other ancient Church tones.

A very striking characteristic of this heavenly hymn is the strictly doctrinal form in which it is composed, which makes it a literal illustration of St. Paul's words, "I will sing with the spirit, and I will sing with the understanding also" (1 Cor. xiv. 15). It has been thought by some, from the singularity of the opening words, *Te Deum*, that it is throughout a hymn to Christ as God, representing, or analogous to, that spoken of by Pliny in his letter to Trajan. But the English version truly represents the Latin form, in which a double accusative is joined to the verb

laudamus that could not be otherwise rhythmically translated. That the English Church has always considered the earlier verses of it to be addressed to the First Person of the Blessed Trinity is evidenced by the ancient Salisbury Antiphon to the Athanasian Creed, which is "*Te Deum Patrem ingnitum, te Filium unigenitum, te Spiritum Sanctum Paracletum, sanctam et individuum Trinitatem toto corde et ore confitemur.*" It has also been conjectured that the 11th, 12th, and 13th verses have been interpolated, but there is not the slightest ground for this conjecture, all ancient MSS. in Latin, Teutonic of the ninth Century, and English from the ninth to the fourteenth, reading precisely the same : and the hymn being rendered imperfect by their omission.

The first ten verses are an offering of praise to the Father Almighty, with the Scriptural recognition of the Blessed Trinity implied in the *Ter Sanctus* which Isaiah heard the Seraphim sing when he beheld the glory of Christ, and spake of Him. In the three following verses this implied recognition of the Three in One is developed into an actual ascription of praise to each, the *Pater immensa Majestatis*, the *Unicus Filius*, and the *Sanctus Paracletus Spiritus*. In these thirteen verses the Unity and Trinity of the Divine Nature is celebrated in the name of the whole Church of God. The Militant Church, the various orders of holy Angels with which it has fellowship in the New Jerusalem, the Apostles, Prophets, and Martyrs of the Old and New Dispensation now gathered into the Church Triumphant, all thus adore God the Lord, the Lord God of Sabaoth, the Father Everlasting : and the holy Church gathers up its praises in a devout acknowledgment of each Person of the Blessed Trinity as the Object of Divine worship. Then begins that part of the Hymn which glorifies God for the blessing of the Incarnation : the latter sixteen verses addressing themselves to our Lord and Saviour ; commemorating His Divine Nature and Eternal Existence, His Incarnation, Sacrifice, Ascension, and Session at the right hand of the Father. In the last verses, with a mixture of plaintiveness and triumph, the hymn follows the line marked out by the angels at the Ascension, looking to our Lord's Second Advent as the true complement of His First. This concluding portion is as well fitted to express the tone of a Church Militant as the initial portion is to express that of a Church Triumphant : and the personal form of the last verse is a touching reminder of the individual interest that each of us

Habakkuk (Hab. iii.) being equally suitable for Advent. The Salisbury version of the latter (from the Vulgate) had two beautiful renderings of the 13th and 18th verses : "Thou wentest forth for the salvation of Thy people : even for salvation with Thy Christ ;" and "Yet I will rejoice in the Lord : I will joy in God my Jesus "

Pi. cxliii. 3.
xxxiii. 18. 22. O Lord, have mercy upon us : have mercy upon us.

Isa. xxvi. 3, 4.
Ps. xxxii. 11.
lxvii. 1. O Lord, let thy mercy lighten upon us : as our trust is in thee.

Ps. xxxi. 1.
Isa. xlv. 17.
1 Pet. ii. 6. O Lord, in thee have I trusted : let me never be confounded.

¶ Or this Canticle, *Benedicite, Omnia Opera.*

The Song of
the three holy
children 35—
66.
Ps. cxlviii. 1.
— 2. O ALL ye Works of the Lord,
bless ye the Lord : praise him,
and magnify him for ever.

O ye Angels of the Lord, bless ye the Lord : praise him, and magnify him for ever.

O ye Heavens, bless ye the Lord : praise him, and magnify him for ever.

— 4. O ye Waters, that be above the Firmament, bless ye the Lord : praise him, and magnify him for ever.

O all ye Powers of the Lord, bless ye the Lord : praise him, and magnify him for ever.

— 3. O ye Sun, and Moon, bless ye the Lord : praise him, and magnify him for ever.

— 3. O ye Stars of Heaven, bless ye the Lord : praise him, and magnify him for ever.

Miserere nostri, Domine : miserere nostri.

Fiat misericordia tua, Domine, super nos : quemadmodum speravimus in te.

In te, Domine, speravi : non confundar in æternum.

Canticum trium puerorum. Dan. iii.

BENEDICITE omnia opera Domini Domino : laudate et superexaltate eum in sæcula. *Salisbury Use.*

Benedicite Angeli Domini Domino : benedicite cœli Domino.

Benedicite aquæ omnes quæ super celos sunt Domino : benedicite omnes virtutes Domini Domino.

Benedicite sol et luna Domino : benedicite stellæ cœli Domino.

has in the corporate work of praise and prayer of which Divine Service is constituted. Few uninspired compositions give so clear an echo of the spirit and depth of Holy Scripture.

There are three verses of the Te Deum which require special notice, with reference to the modern Latin and English in which they are given to us at the present day.

(1) The ninth verse, "Te Martyrum *candidatus*, laudat exercitus," is very insufficiently rendered by "The noble army of Martyrs praise Thee." In pre-Reformation versions it stood,— "The, preiseth the white oost of martiris;" and considering the distinct connexion between this verse and Rev. vii. 9. 14, it is strange that the Scriptural idea of "white robes" which have been "made white in the blood of the Lamb," should have been superseded by the word "noble." It is possible that the idea of something lustrous and pure was more expressed by "noble" in the early part of the sixteenth century, than is conveyed by it to modern ears; but the change of the word from the old English "white," and Anglo-Saxon "shining," has gone far to obliterate the true sense of the original in our present version.

(2) In the sixteenth verse, the ancient and modern English versions alike fail to give the full sense of the Latin. The former uniformly give, "Thou wert not skoymes (squeamish) to take the maydenes wombe, to delyver mankynde," which is little different in sense from our present version. But it is clear that "Tu, ad liberandum, *suscepturus hominem*" includes a reference to the Incarnation, as much as "non horruisti Virginis uterum." The verse would be more literally rendered, "Thou, being about to take manhood upon Thee, to deliver it;" but there is an almost insurmountable difficulty in the way of matching the point and rhythm of the Latin by an equivalent sentence in English.

(3) The twenty-first verse has been altered both in Roman Breviaries and in the English Prayer Book. All Latin MSS.

previously to 1492, read "Æterna fac cum sanctis Tuis gloria *munerari*:" and the equivalent of *munerari* is found in every known version of the Te Deum up to that time; our own in the fourteenth century being, "Make hem to be rewarded with thi seyntes, in endles blisse." The "numerari" reading appears to be an error of the early printers, arising out of the very slight difference presented by *mun* and *num* in black letter.¹ The word "in" is a modern insertion of the same date, and probably arose from confusion between the twenty-first and the eighteenth verses, in the latter of which occurs "*in gloria Patris*." Since our Lord said "Great is your reward in Heaven," and "Himself shall reward you openly," the old English rendering of *munerari* is quite Scriptural; but it may be pointed out that the sense of the Latin is rather that of free gift than reward, *munerari*, not *re-munerari*. Perhaps the original may be rendered, "Make them to be awarded with Thy saints: Thy glory everlasting," without departing from the sense of the original, or the familiar rhythm of our Prayer Book version. The received version although not faithful to the original, is happily comprehensive; for, to be "numbered with the children of God," and to have a "lot among the saints," is to receive the "great recompense of reward," the heavenly heritage of those who are joint heirs with Christ of His triumphant kingdom.

THE BENEDICITE.

There is no doubt that this Canticle is of Jewish origin, although its claim to be part of the Canonical Book of Daniel is

¹ It should, however, be mentioned that the Venerable Bede, who was almost contemporary with Gregory the Great, records some words of his which contain something very like this reading. "Sed et in ipsa missarum celebratione tria verba maximæ perfectionis plena superadjecit, 'Diesque nostros in tua pace disponas, atque ab æterna damnatione nos eripi, et electorum tuorum jubeas grege numerari.'"—Bede, Hist. Eccl., lib. 2, c. i.

¹ So gold and silver were called "noble metals" by the early chymists.

Ps. cxlviii. 8.

O ye Showers, and Dew, bless ye the Lord : praise him, and magnify him for ever.

O ye Winds of God, bless ye the Lord : praise him, and magnify him for ever.

O ye Fire, and Heat, bless ye the Lord : praise him, and magnify him for ever.

O ye Winter, and Summer, bless ye the Lord : praise him, and magnify him for ever.

O ye Dews, and Frosts, bless ye the Lord : praise him, and magnify him for ever.

O ye Frost, and Cold, bless ye the Lord : praise him, and magnify him for ever.

O ye Ice, and Snow, bless ye the Lord : praise him, and magnify him for ever.

O ye Nights, and Days, bless ye the Lord : praise him, and magnify him for ever.

O ye Light, and Darkness, bless ye the Lord : praise him, and magnify him for ever.

O ye Lightnings, and Clouds, bless ye the Lord : praise him, and magnify him for ever.

O let the Earth bless the Lord : yea, let it praise him, and magnify him for ever.

O ye Mountains, and Hills, bless ye the Lord : praise him, and magnify him for ever.

O all ye Green Things upon the Earth, bless ye the Lord : praise him, and magnify him for ever.

O ye Wells, bless ye the Lord : praise him, and magnify him for ever.

O ye Seas, and Floods, bless ye the Lord : praise him, and magnify him for ever.

Benedicite imber et ros Domino : Salisbury Usa.
benedicite omnes spiritus Dei Domino.

Benedicite ignis et æstus Domino :
benedicite frigus et æstas Domino.

Benedicite rores et pruina Domino :
benedicite gelu et frigus Domino.

Benedicite glacies et nives Domino .
benedicite noctes et dies Domino.

Benedicite lux et tenebræ Domino :
benedicite fulgura et nubes Domino.

Benedicat terra Dominum : laudet
et superexaltet eum in sæcula.

Benedicite montes et colles Domino :
benedicite universa germinantia in
terra Domino.

Benedicite fontes Domino : benedi-
cite maria et flumina Domino.

not recognized by the Church of England, which has placed it among the books of the Apocrypha. It has a great resemblance to the 148th Psalm, and is generally considered to be a paraphrase of it.

Several of the Fathers speak of the Benedicite as being used in the Services of the Church. St. Chrysostom especially refers to it as "that admirable and marvellous song, which from that day to this hath been sung every where throughout the world, and shall yet be sung in future generations." Rufinus speaks of it in the same manner, (in defending its Canonical authority against Jerome¹), as having been sung by holy confessors and martyrs,

¹ It is inserted in the Comes of St. Jerome among the Lections on the

who would not have been permitted to sing that as Holy Scripture which is not so. It was used as one of the Psalms at Lauds as early as the time of St. Athanasius, and occupied the same position on Sundays in the ancient services of the Church of England. When the Psalter was restricted, in 1549, to the hundred and fifty psalms which go by the general name of the Psalms of David, the Song of the Three Children was placed after the Te Deum, to be used as a responsory canticle to the first lesson, under the title "Benedicite, Omnia Opera Domini Domino." This use of it was not by any means novel, as it was

Festival called *Statio ad S. Petrum* under the title "Hymnus Trium Puerorum."

O ye Whales, and all that move in the Waters, bless ye the Lord : praise him, and magnify him for ever.

Ps. cxlviii. 10.

O all ye Fowls of the Air, bless ye the Lord : praise him, and magnify him for ever.

O all ye Beasts, and Cattle, bless ye the Lord : praise him, and magnify him for ever.

O ye Children of Men, bless ye the Lord : praise him, and magnify him for ever.

O let Israel bless the Lord : praise him, and magnify him for ever.

Ps. cxxxiv. 1.

O ye Priests of the Lord, bless ye the Lord : praise him, and magnify him for ever.

O ye Servants of the Lord, bless ye the Lord : praise him, and magnify him for ever.

O ye Spirits, and Souls of the righteous, bless ye the Lord : praise him, and magnify him for ever.

O ye holy and humble Men of heart, bless ye the Lord : praise him, and magnify him for ever.

Ps. cxxxvi. 1.

O Ananias, Azarias, and Misael, bless ye the Lord : praise him, and magnify him for ever.

Glory be to the Father, and to the Son : and to the Holy Ghost ;

As it was in the beginning, is now, and ever shall be : world without end. Amen.

¶ *Then shall be read in like manner the Second Lesson, taken out of the New Testament. And after that, the Hymn following; except when that shall happen to be read in the Chapter for the Day, or for the Gospel on St. John Baptist's Day.*

Benedictus.
Luke i. 68.

BLESSED be the Lord God of Israel : for he hath visited, and redeemed his people ;

Benedicite cete et omnia quæ moventur in aquis Domino : benedicite omnes volucres cæli Domino. Salisbury Use.

Benedicite omnes bestię et pecora Domino : benedicite filii hominum Domino.

Benedicat Israël Dominum : laudet et superexaltet eum in sæcula.

Benedicite Sacerdotes Domini Domino : benedicite servi Domini Domino.

Benedicite spiritus et animæ iustorum Domino : benedicite sancti et humiles corde Domino.

Benedicite Anania, Azaria, Misael Domino : laudate et superexaltate eum in sæcula.

Benedicamus Patrem et Filium cum Sancto Spiritu : laudemus et superexaltemus eum in sæcula. Cf. Dan. iii. 52. 56. Vulg.

Benedictus es Domine in firmamento cæli : et laudabilis, et gloriosus, et superexaltatus in sæcula.

Canticum Zacharię prophete Luca i.

BENEDICTUS Dominus Deus Israël : quia visitavit, et fecit redemptionem plebis suę. Salisbury Use.

said between the lessons (according to Mabillon), in the old Gallican ritual which was once common to France and England.

When first inserted in its present place, this Canticle was ruled by the following rubric prefixed to the Te Deum :— "¶ After the first lesson shall follow throughout the year (except in Lent, all the which time, in the place of *Te Deum*, shall be used *Benedicite Omnia Opera Domini Domino*) in English, as followeth." This rubric was altered to its present form in 1552, the object of the alteration being probably to allow greater freedom in the substitution of *Benedicite* for *Te Deum*. It was an ancient rule to use the former when any portion of the Prophet Daniel was read. In more recent times it has been customary to sing it on Septuagesima Sunday, when Genesis i. is the first lesson; on the Nineteenth Sunday after Trinity when Daniel iii.

is read; and on week-days during Lent and Advent¹. The ordinary Doxology was substituted for the one proper to the psalm, in 1549. The latter is, "O let us bless the Father, and the Son, with the Holy Ghost : let us praise Him, and magnify Him for ever. Blessed art Thou, O Lord, in the firmament of Heaven; worthy to be praised, and glorious, and to be magnified for ever." Pope Damasus (A.D. 366) is said to have been its author; but it is founded on the verse which precedes the words *Benedicite Omnia Opera*.

THE BENEDICTUS.

This prophetic hymn of Zacharias has been used as a responsory canticle to the Gospel lessons from very ancient times, being

¹ See however, note on p. 11.

And hath raised up a mighty salvation for us : in the house of his servant David ;

As he spake by the mouth of his holy Prophets : which have been since the world began ;

That we should be saved from our enemies : and from the hands of all that hate us ;

To perform the mercy promised to our forefathers : and to remember his holy Covenant ; .

To perform the oath which he sware to our forefather Abraham : that he would give us ;

That we being delivered out of the hands of our enemies : might serve him without fear ;

In holiness and righteousness before him : all the days of our life.

And thou, Child, shalt be called the Prophet of the Highest : for thou shalt go before the face of the Lord to prepare his ways ;

To give knowledge of salvation unto his people : for the remission of their sins,

Through the tender mercy of our God : whereby the Day-spring from on high hath visited us ;

To give light to them that sit in darkness, and in the shadow of death : and to guide our feet into the way of peace.

Glory be to the Father, and to the Son : and to the Holy Ghost ;

As it was in the beginning, is now, and ever shall be : world without end. Amen.

Et erexit cornu salutis nobis : in Salisburie Use, domo David pueri sui.

Sicut locutus est per os sanctorum : qui a sæculo sunt, prophetarum ejus.

Salutem ex inimicis nostris : et de manu omnium qui oderunt nos.

Ad faciendam misericordiam cum patribus nostris : et memorari testamenti sui sancti.

Jusjurandum quod juravit ad Abraham patrem nostrum : daturum se nobis.

Ut sine timore, de manu inimicorum nostrorum liberati : serviamus illi.

In sanctitate et justitia coram ipso : omnibus diebus nostris.

Et tu, puer, Propheta Altissimi vocaberis : præbis enim ante faciem Domini parare vias ejus.

Ad dandam scientiam salutis plebi ejus : in remissionem peccatorum eorum.

Per viscera misericordiae Dei nostri : in quibus visitavit nos oriens ex alto.

Illuminare his qui in tenebris et in umbra mortis sedent : ad dirigendos pedes nostros in viam pacis.

Gloria Patri, et Filio : et Spiritui Sancto.

Sicut erat in principio, et nunc, et semper, et in sæcula sæculorum. Amen.

spoken of as so used by Ananarius (A.D. 820) ; and perhaps by St. Benedict, nearly three centuries earlier, since he speaks of a *Canticum de Evangelio* occurring here in Mattins. In the Salisbury Use it occupied a similar position, but was not so definitely connected with the lessons themselves as it now is, being used after the Capitulum, at Lauds, on Sundays. It was the only Canticum appointed for use after the second morning lesson in 1549, and the rubric by which it is preceded shows very clearly that it is intended to be the ordinary Canticum, the *Jubilate* being an exceptional one, inserted to avoid repetition on St. John Baptist's Day, or whenever the Benedictus occurs in the second lesson itself.

The position of this Canticum makes its ritual meaning self-evident. It is a thanksgiving to Almighty God for His mercy as exhibited towards mankind in the Incarnation of our Lord, whereof the Gospel speaks, and in the foundation of the Church in His blood, as recorded in the Acts of the Holy Apostles. It is

the last prophecy of the old Dispensation, and the first of the new : and furnishes a kind of key to the Evangelical interpretation of all prophecies under the one by which they are connected with the other. The Benedictus is a continual acknowledgment also of the Communion of Saints under the two Dispensations ; for it praises God for the salvation which has been raised up for all ages out of the house of His servant David, and according to the ancient covenant which He made with Abraham, "the father of them that believe, though they be not circumcised" (Rom. iv. 11) ; whose seed all are if they are Christ's, and heirs according to the promise. (Gal. iii. 29.) The use of the Benedictus by the Church indicates to us where we are to find true sympathy and communion with God's ancient people ; not in their outward relationship to Abraham, "for God can of these stones raise up children unto Abraham," but in their faithful acknowledgment of the Lord Jesus, as the Christ whom the Old Testament Scriptures predicted.

¶ Or this Psalm, *Jubilate Deo.*

* Ps. c.

O BE joyful in the Lord, all ye lands : serve the Lord with gladness, and come before his presence with a song.

Be ye sure, that the Lord he is God : it is he that hath made us, and not we ourselves ; we are his people, and the sheep of his pasture.

O go your way into his gates with thanksgiving, and into his courts with praise : be thankful unto him, and speak good of his Name.

For the Lord is gracious, his mercy is everlasting ; and his truth endureth from generation to generation.

Glory be to the Father, and to the Son : and to the Holy Ghost ;

As it was in the beginning, is now, and ever shall be : world without end. Amen.

¶ *Then shall be sung or said 'the Apostles' Creed by the Minister and the people, standing : except only such days as the Creed of Saint Athanasius is appointed to be read.*

² Tim. i. 13.
Deut. iv. 33, 39.
Matt. vi. 9.
Gen. i. 1. xvii. 1.
John i. 3.
Matt. i. 18—25.

I BELIEVE in God the Father Almighty, Maker of heaven and earth :

Psalmus xcix.

JUBILATE Deo omnis terra : *ser-* Salisbury Use.
vite Domino in lætitia.

Introite in conspectu ejus : in exultatione.

Scitote quoniam Dominus, ipse est Deus, ipse fecit nos, et non ipsi nos.

Populus ejus et oves pascuæ ejus, introite portas ejus in confessione : atria ejus in hymnis ; confitemini illi.

Laudate nomen ejus ; quoniam suavis est Dominus ; in æternum misericordia ejus : et usque in generationem et generationem veritas ejus.

Gloria Patri, et Filio : et Spiritui Sancto.

Sicut erat in principio, et nunc, et semper : et in sæcula sæculorum. Amen.

Symbolum Apostolicum.

CREDO in Deum Patrem omnipotentem, Creatorem cœli et terræ. Et in Jesum Christum Filium

THE JUBILATE.

This was the second of the fixed Psalms at Lauds on Sunday ; and was adopted as a responsory Canticle in 1552. The object of its insertion here was to provide a substitute for the Benedictus on days when the latter occurs in the Lesson or Gospel, on the same principle which rules the omission of the Venite when it occurs in the Psalms of the day. The days on which it should be used are therefore the following :—

February 18th.
June 17th.
June 24th [St. John Baptist's Day].
October 15th.

The general substitution of the Jubilate for the Benedictus is very much to be deprecated. There is, however, a prophetic reference to the Chief Shepherd of the Church, and to the service of praise offered to Him which makes it well fitted for occasional use ; and Dean Comber says that it seems to have been used after the reading of the Gospel as early as A.D. 450.

THE APOSTLES' CREED.

The use of a Creed in Divine Service is of very ancient origin, and the Apostles' Creed has been used in the daily offices of the Church of England as far back as they can be traced. Under the old system it followed the Lord's Prayer, (instead of preceding it,) at Prime and Compline, and was recited in the same manner, the people joining in only at a repetition of the last two clauses. In the Reformed Breviary of Cardinal Quignonez an open recitation of the Apostles' Creed was directed on all days except Sunday : and this direction probably suggested our present custom.

The earliest occurrence of the Apostles' Creed exactly in the form in which we now use it at Morning and Evening Prayer, is in a treatise published by Mabillon, from an ancient MS., entitled

"*Libellus Pirminii de singulis libris canonicis scarapsus,*" or "*scriptus.*" Pirminius died about A.D. 758, and appears to have lived some time in France, though he died in Germany. Hence it is extremely probable that the Creed contained in two several places of his treatise, and in both places in the same words, is the old Gallican form of the Apostles' Creed, identical with that afterwards adopted by St. Osmund into the Salisbury Use, from the more ancient services of the Church of England. How much older than the eighth century this exact form of the Apostles' Creed may be is not known ; but it has been so used, without variation, in the whole Latin Church, as well as in the Church of England, from that time until the present.

The substance of the Apostles' Creed is, however, very much older. It is extant, very nearly as we now use it, as it was used by the Churches of Aquileia and Rome at the end of the fourth century, when it was commented upon, and both forms indicated, by Rufinus, who was a priest of the former diocese. The two forms are here shown side by side, the authority for each being Professor Heurtley's *Harmonia Symbolica*, pp. 26, 30 :—

The Creed of the Church of Aquileia, circ. A.D. 390. *The Creed of the Church of Rome, circ. A.D. 390.*

Crede in Deum Patrem omnipotentem, invisibilem et impassibilem : Et in Jesum Christum, unicum Filium ejus, Dominum nostrum ; Qui natus est de Spiritu Sancto Ex Maria Virgine ; Crucifixus sub Pontio Pilato, et sepultus ; Tertia die resurrexit a mortuis ; Ascendit in cœlos ; Sedet ad dexteram Patris ; Inde venturus est judi-

Luke ii. 11, 21. And in Jesus Christ, his only Son
 ii. 1-7.
 Matt. xxvii. 1, 2. our Lord, Who was conceived by the
 26-31, 35. Holy Ghost, Born of the Virgin Mary,
 Mark xv. 42-46. Suffered under Pontius Pilate, Was,
 Ps. xvi. 8. crucified, dead, and buried; He de-
 Acts ii. 24-32. scended into Hell; The third day he
 Matt. xxviii. rose again from the dead, He ascended
 Ps. lxxviii. 18. into heaven, And sitteth on the right
 Acts i. 9. hand of God the Father Almighty;
 Mark xvi. 19. From thence he shall come to judge
 Matt. xxv. 31-46. the quick and the dead.
 John v. 21-23. I believe in the Holy Ghost; The
 Acts x. 42. holy Catholic Church; The Com-
 Eph. ii. 18-22. munion of Saints; The Forgiveness
 2 Cor. xiii. 14. of sins; The Resurrection of the body,
 John xv. 16, 17. And the life everlasting. Amen.
 26.
 Col. i. 12, 13, 18. I believe in the Holy Ghost; The
 Luke xxiv. 47. holy Catholic Church; The Com-
 John v. 28, 29. munion of Saints; The Forgiveness
 Rev. xx. 12, 13. of sins; The Resurrection of the body,
 John iii. 16. And the life everlasting. Amen.
 v. 24.
 2 Pet. i. 11.
 Rev. xxii. 20.

ejus unicum, Dominum nostrum: qui Salisburys Usa.
 conceptus est de Spiritu Sancto, natus
 ex Maria Virgine, passus sub Pontio
 Pilato, crucifixus, mortuus, et sepultus:
 descendit ad inferna: tertia die resur-
 rexit a mortuis: ascendit ad cœlos:
 sedet ad dexteram Dei Patris omni-
 potentis: inde venturus est judicare
 vivos et mortuos. Credo in Spiritum
 Sanctum: sanctam Ecclesiam Catho-
 licam: Sanctorum communionem, re-
 missionem peccatorum, carnis resur-
 rectionem, et vitam æternam. Amen.

Sedet ad dexteram Patris. Inde care vivos et mortuos; Et in
 venturus est judicare vivos et Spiritu Sancto; Sanctam Ecce-
 mortuos; Et in Spiritu Sancto; siam; Remissionem peccato-
 Sanctam Ecclesiam; Remis- rum; Carnis resurrectionem.
 sionem peccatorum; Hujus car-
 nis resurrectionem.

At a still earlier period, A.D. 180, Irenæus wrote his great work against heresies; for, even at that early date, these began to fulfil the prophecy of our Lord that the Enemy should sow tares among the wheat. In this book Irenæus gives the substance of Christian doctrine under the name of the "Rule of Truth," which every Christian acknowledged at his Baptism. This undoubtedly represents the Apostles' Creed, though probably not the exact words in which it was recited.

The Creed as stated by Irenæus, Bishop of Lyons, A.D. 180.

The Church throughout the world, spread out as she is to the ends of the earth, carefully preserves the faith that she received from the Apostles and from their disciples:—

Believing in one God the Father Almighty, Who made Heaven and Earth, the seas and all that in them is; and in one Christ Jesus, the Son of God, Who was incarnate for our salvation; and in the Holy Ghost, Who by the prophets proclaimed the dispensations and the advents of our dear Lord, Christ Jesus: and His birth of a Virgin, and His suffering, and His Resurrection from the dead, and His Ascension in the flesh into Heaven, and His coming from Heaven in the glory of the Father, to sum up all things, and to raise up all flesh of the whole human race.

That to Christ Jesus our Lord, and God, and Saviour, and King, according to the good pleasure of the invisible Father, every knee should bow, of things in heaven, and things in earth, and things under the earth; and that every tongue should confess Him, and that He should pass righteous judgment upon all.

In two other parts of the same work there are other summaries of the Creed which are plainly based on the same formula as that of which the above is a paraphrastic statement.

Traces of the Creed are also to be found in the writings of Justin Martyr, Polycarp, Clemens Romanus, and Ignatius: and these approach so near to Apostolic times as to give good reason to think that the name by which the Apostles' Creed has been known for many centuries, is one which belongs to it not merely because it accurately states the faith held by the Apostles, but also because it originated from them.

A very ancient tradition of the Church, as old as the time of Rufinus (A.D. 369-410), describes the Apostles as meeting together to consider about a common statement of doctrine, before they parted for their several labours. A later tradition

(attributed to St. Augustine, but probably of more recent date) adds to this statement that each Apostle in succession recited one Article of the Creed, implying that it was thus delivered by Inspiration. The first of these traditions, written down so near to the time of the Apostles, is worthy of great respect: and no objections have been made to it, which have not been rationally answered. The second is not of high authenticity, but the objections brought against it are chiefly founded on the improbability of such a statement being true: yet if the inspiration of the Apostles for the purpose of writing special official letters is granted, it is difficult to see what there is improbable in a statement that implies their collective inspiration for the purpose of originating so important a document as the Creed, at a time when the New Testament Scriptures had not yet come into existence.

But, apart from these traditions, there is much evidence in the early Christian writings that there was a common and well-known formula containing the chief articles of Christian faith. There are also frequent statements that the tradition of the Faith came direct from the Apostles. Combining these facts with the supposition that the Apostles would almost certainly provide some such formula for the guidance of converts, we may conclude that it is far more reasonable to believe the Creed going under their name to be substantially of their composition than to believe the contrary. In fact the Creed appears to be an absolute necessity, springing out of the circumstances in which the early Christians were placed: when, as regarded themselves, their brethren, and the Heathen, such an answer to the question, "What is Christianity?" resolving itself into a few short replies embodying the chief facts of our Lord's life and work, was imperatively required. That the Apostles would methodize an authoritative form of this reply can hardly be doubted: and that they did so is more than suggested by what St. Paul says of a Form of sound words in passages like Rom. vi. 17; xvi. 17. Heb. x. 23. Phil. iii. 16. 2 Tim. i. 13, the original Greek of which almost necessitates such an interpretation as that here indicated.

Although, however, the cumulative force of these arguments is so great as to leave scarcely any rational ground for contradicting the old belief of the Church, that the Creed came from the Apostles substantially as it was handed down to the eighth century, it is not sufficient to warrant us in declaring it to be inspired. All that we may dare to say on this point is, that the Apostles were under a very special guidance of the Holy Ghost, were "filled with the Spirit" for the official purposes of their work; and, consequently, that very little of the human element is likely to have mingled itself with any of the official words which they spoke to the Church. If it could be certainly proved that the Creed came from the Apostles as we now have it, sound reason would require us to believe that the Holy Ghost moved

them to compose it, and hence that it was inspired. In the absence of such evidence it is our duty to compare the doctrines handed down to us in the Creed as those of the Apostles, with the doctrines contained in the great storehouse of God's Truth.

This is done to some extent in the marginal references above; and in the following Table it will be seen how near an agreement there is between the statements contained in the Creed and those made by the Apostles in their early missionary work¹:—

Statements of Apostles, &c., expressing belief in	God the Father.	God the Son.	God the Holy Ghost.	Our Lord's Sufferings.	Our Lord's Resurrection.	Our Lord's Ascension.	Our Lord's Second Coming.	Repentance.	Forgiveness of Sins.	The Church.
St. Matthew xxviii.	19	19	19		10					19, 20
St. Luke xxiv.	49	49	49 Acts i. 4, 8.	46	46	51 Acts i. 9.	Acts i. 11.	47	47	49 Acts i. 6.
St. John xx.	17	17	22		9. 20. 28	17	xxi. 22		xx. 23	21, 23
St. Peter, Acts ii.	17	22, 23, 24	17. 33. 38	23	24. 31, 32	[Mark xvi. 19.] 33		38	38	32
Acts iii.	13	13. 15		15	15	21	19—21	19. 26	19	15
Acts iv.	24	12. 27. 30		10. 27	10					
Acts v.	30	31	32	30	30	31		31	31	32
Acts x.	34—36	38	38	39	40, 41		42		43	41, 42
St. Stephen, Acts vii.	2. 32. 37. 55	52. 55	51	52	55, 56	55, 56				
St. Paul, Acts xiii.	17. 23	23. 33. 35		28	30. 33. 34. 37				38	31
Heb. vi.	1	1. 6	4	6	2		2	1. 6		

Such a coincidence goes far towards showing that the Apostles' Creed is a "Form of sound words" handed down to us on the very highest authority. It may also convince us that it would be an irreverent and uncritical error to speak of it positively as a human composition.

The central position of the Creed in our Morning and Evening Service gives it a twofold ritual aspect. Praise has formed the distinctive feature of what has gone before, prayer forms that of what is to follow. The confession of our Christian faith in the Creed is therefore, (1) like a summing up of the Scriptures that have been used for the praise of God and the edification of His Church: and by its recitation we acknowledge that it is

"Him first, Him last, Him midst, and without end,"

whom we find in Moses, the Prophets, the Psalms, the Gospels, and the Epistles. Not only in respect to ourselves, as a fit reminder of this great truth, do we thus confess our faith, but also to the praise of God; and hence the rubric directs the Creed to be "sung" (the word was inserted by Bishop Cosin) if circumstances will permit, as the Nicene Creed and the Athanasian Creed always have been. And (2) the recitation of the Creed is a confession of that objective faith which alone can give full reality to prayer;

hence it is a foundation of, and introduction to, the Præces and the Collects with which the Service concludes. "For this reason it is, probably, that baptisms were ordered to take place after the second lesson; that so the admission of the newly baptized might be followed by *liturgical* avowal, so to speak, of that Creed, and saying of that Prayer, which, as a part of the rite, have already been avowed and used²."

There are two customs connected with the recitation of the Creed which require notice; the one, that of turning to the East, or towards the Altar, in saying it; the other, that of bowing at the holy Name of Jesus. Both of these customs are relics of habits which have only ceased to be universal (in the English Church, at least) in very modern times.

Clergy and people used formerly to look one way throughout the prayers and Creeds, that is, towards the Altar. "In some Churches," writes Thorndike³, "the desk for the Prayer Book looks towards the Chancel; and for reading of Lessons we are directed to look towards the people. As the Jews in their

¹ Harvey on the Creeds, i. 20.

² Principles of Divine Service, i. 361.

³ Religious Assemblies, p. 231.

prayers looked towards the Mercy-seat or principal part of the Temple (Ps. xxviii. 2), so Christians looked towards the Altar or chief part of the Church, whereof their Mercy-seat was but a type. Christ in His prayer directs us to Heaven, though God be every where; for Heaven is His throne, and we look toward that part of the church which most resembles it. Herein we correspond to the Jewish practice.¹ Before reading-desks were erected in the naves of Churches, the prayers were said in front of the Altar itself, as may be seen in old prints; while the Psalms were sung in the choir stalls: and this was a continuation of the ancient practice¹, the officiating Clergyman always standing or kneeling in the former place to say Creeds and Prayers. When pews as well as reading-desks sprang up in Churches, both congregation and clergy were often placed in any position that suited the convenience of the carpenter; but reverence still impelled all to turn towards the Altar during the solemn Confession of their Faith. Hence this habit became exceptional and prominent instead of habitual; and exceptional reasons were alleged in support of it, when in fact they applied, with more or less force, to the general posture of the worshipper in God's House, as expressed in the preceding extract. Apart, also, from symbolical explanations of this custom, it appeals to both the reason and the feelings, by forming the congregation into a body of which the clergyman is the leader, as when a regiment marches into battle, or parades before its Sovereign headed by its officers: and there is no part of Divine Service where this relation of priest and people is more appropriate than in the open Confession of Christian Faith before God and man.

Bowing at the holy Name of our Lord's Human Nature is also an usage of general application, and was never intended to be restricted to the Creed, although its omission there would certainly be a more special dishonour to Him than elsewhere. When Puritan superstition sprang up in the sixteenth century, the usage began to be dropped by many who were seduced by controversy into greater respect for doctrines of slighter importance than that of our Lord's Divinity. The Church then made a law on the subject of reverent gestures in Divine Service, in the 18th Canon of 1603; in which (after ordering that all shall stand at the Creed) is the following clause, founded on the 52nd of Queen Elizabeth's Injunctions, issued in 1559:—"And likewise, when in time of Divine Service the Lord Jesus shall be mentioned, due and lowly reverence shall be done by all persons present, as hath been accustomed: testifying by these outward ceremonies and gestures their . . . due acknowledgment that the Lord Jesus Christ, the true and eternal Son of God, is the only Saviour of the world, in Whom all the mercies, graces, and promises of God to mankind, for this life, and the life to come, are fully and wholly comprised." This general rule of the Church, and the explanation thus authoritatively given, has so special an application to the use of this gesture in the Creed that nothing further need be added on the subject.

§. *An Expository Paraphrase of the Apostles' Creed.*

I, for myself, as personally responsible for my faith to God and His Church, openly profess, to His glory, that I believe, from my heart, with the assent of my reason and the submission of my will,

in God the Father, by a mysterious, unintelligible manner of paternity, Father of the uncreated, co-equal, and co-eternal Son: Father also of all the regenerated, by their adoption through His thus only-begotten Son:

Almighty, so that nothing is beyond His power which is consistent with goodness; knowing all things past, present, and to come; exercising authority over all things and persons, and upholding all things by His universal and omnipresent Providence: I believe that He was and is the

Maker, that is, the original Creator of the original matter, and the Disposer of that material in fit order,

¹ The exact routine of the ancient practice may be seen in "¶ Of the turning of the Choir to the Altar," one among several extracts from the Consuetudinary of Sarum, printed at the end of Mr. Chambers' Translation of the Sarum Psalter, p. 434.

of Heaven, which comprehends all that has originally occupied space beyond this world,

and Earth, which comprehends all organic and inorganic beings and substances within the compass of this world.

And I equally believe

in Jesus, perfect Man, in all the qualities of human nature, Christ, anointed to be the Saviour of the world, the High Priest of a new order of priesthood, the King of Kings and Lord of Lords,

His only Son, eternally begotten, and therefore having such a Sonship as none others who call God Father can possess,

our Lord, being God, the Second Person in the Blessed Trinity, as well as Man; Lord of all by His Divine Nature, Lord of the Church by His work of Redemption. Thus I believe in the Eternal Son of the Eternal Father, in a Saviour Divine and Human,

Who was conceived by the Holy Ghost, through a mysterious and unintelligible operation, which miraculously superseded the ordinary law of nature, so that the Holy Child Jesus was

Born of the Virgin Mary, a holy maiden, who thus miraculously became His mother that He, being born of a Virgin and not of a wife, might be free from the sin of our common origin, which is conveyed from parent to child by natural conception. Being thus born in our nature, but without our sin, He bore it as His own through infancy, childhood, and mature manhood; and when the time was fully come, He offered it as a sacrifice for our sins when He

Suffered under Pontius Pilate, the Roman Governor of Judæa and Jerusalem, and

Was crucified, by being nailed alive to a cross of wood, set upright in the ground. Being thus crucified, His sufferings were the greatest that had ever befallen any man, being aggravated by the burden of sin which He, though innocent, was bearing for our sakes. Not through the intensity of His sufferings, but of His own will, He gave up His life when all was accomplished that could be by His pains, and then was

dead, through the separation of His soul from His body, in the same manner as human beings ordinarily become so. Being dead, His holy Body, still the Body of the Son of God, was taken down from the cross,

and buried, with reverence and honour, but as the dead bodies of other men are. And while the dead Body of the Son of God was in the tomb, with His living Soul

He descended into Hell, that He might there triumph over Satan; proclaim the glad tidings of salvation to all who had ever died; entirely release the souls of the righteous dead from the power of Satan, and prepare a paradise of rest in which they and all other righteous souls may dwell until the day of judgment.

The third day, after the evening of Friday, the whole of Saturday, and a part of Sunday had passed,

He rose again from the dead, reuniting His soul to His uncorrupted Body, so as to be again "perfect Man" in respect to all the qualities that belong to sinless and unsuffering human nature. Then

He ascended into Heaven, after forty days, as a new Person, God and Man,

And sitteth on the right hand of God the Father Almighty, receiving in His Human Nature, as well as in His Divine Nature, the adoration of angels and men; and by His presence there making a continual intercession for us, and being a Mediator between Divine and human nature for ever.

From thence He shall come, the same holy Jesus who suffered and died,

to judge, with a just, irreversible, and yet merciful judgment, the quick, who shall be alive at His coming, and the dead, who shall have died at any time from the foundation of the world.

I believe, also, with equal faith, and equal assent of my reason,

¶ *And after that, these Prayers following, all devoutly kneeling; the Minister first pronouncing with a loud voice,*

The Lord be with you.

Answer.

And with thy spirit.

Minister.

¶ Let us pray.

Lord, have mercy upon us.

Christ, have mercy upon us.

Lord, have mercy upon us.

Ruth ii. 4.
2 Thess. iii. 16.
Ps. cxlix. 8.
2 Tim. iv. 22.
Ps. cxviii. 26.

Phil. iv. 6.
Matt. xxvi. 44.
Ps. cxliii. 3.
Matt. xx. 30, 31.
2 Cor. iii. 17, 18,
marg.

Deinde dicantur Preces Feriales hoc modo. Salisbury Use.

[Dominus vobiscum.

Et cum spiritu tuo.

Oremus.]

Kyrie eleison. iii.

Christe eleison. iii.

Kyrie eleison. iii.

in the Holy Ghost, the third Person of the Blessed Trinity, the Comforter of the Church, Who ministers in it the grace which the Saviour has gained for it, the Holy Catholic Church, which is the whole number of the baptized, the mystical Body of Christ; which was founded by the twelve Apostles, and is continued in existence by the perpetuation of an Episcopal ministry; which, by the merciful Providence of the Lord, holds the true Faith; which is divided into many separate bodies, all having their own bishops, and is yet one by being united to Christ, our Spiritual and Ministerial Head. I likewise believe in the Communion of Saints, that is, the Union in Christ of all who are one with Him, whether they are among the living in the Church on earth, the departed in paradise, or the risen saints in heaven. I also believe in the Forgiveness of Sins, by the ministration of Christ's Church in Baptism and in Absolution, the Resurrection of the body, when it shall be, as now, my own very body, and reunited to my soul, and the Life Everlasting, wherein the bodies and souls of all who have ever lived will live for ever, they that have done good in never-ending happiness, and they that have done evil in never-ending misery. And, lastly, I reiterate my assent to all these truths, in the presence of God and man, by solemnly adding Amen.

[For notes relating to the use of the Creed at Baptism, and to the Forms of it so used, see the Baptismal Service.]

THE SUFRAGES OR PRECES.

The portion of the daily Service which comes between the Creed and the first Collect was translated, with some alterations, from the Preces Feriales inserted among the *Preces et Memoria Communes* of the Salisbury Portiforium. In 1552, the *Dominus vobiscum* and *Oremus* were prefixed: and the "Clerks and people" (meaning, of course, the choristers and people) were directed to say the Lord's Prayer as well as the Minister.

In the ancient form of the Service the *Kyrie Eleison* was left untranslated in the Greek, like the Alleluia, from a special reverence for the original words, and also as a sign of the universality of the Church's prayers. They are still said in Greek in the Litany used in Convocation. Each *Kyrie* and *Christe* was also repeated three times. The Lord's Prayer was said privately by the Priest as far as the last clause, which was long the custom of the Church, the *Et ne nos, &c.* being repeated aloud that the people might then join. This custom was abolished in 1552. In some cases it appears that the whole was said privately by Clergy and people; and then the last two clauses were said again aloud. [See Transl. Sar. Psalter, 14, n.]

The six versicles and their responses are modified from the ancient form; of which the following is a translation, as far as the Miserere¹ :—

I said, Lord, be merciful unto me.

Heal my soul, for I have sinned against Thee.

Turn us then, O God our Saviour,

And let Thine anger cease from us.

Let Thy merciful kindness, O Lord, be upon us,

Like as we do put our trust in Thee.

Let Thy priests be clothed with righteousness,

And let Thy saints sing with joyfulness.²

O Lord, save the King.

And hear us in the day when we call upon Thee.

Save Thy servants and Thy handmaidens,

Trusting, O my God, in Thee.

O Lord, save Thy people, and bless Thine inheritance,

Rule them, and set them up for ever.

O Lord, grant us peace in Thy strength,

And abundance in Thy towers.

Let us pray for the faithful departed.

Grant them, O Lord, eternal rest,

And let perpetual light shine upon them.

Hear my voice, O Lord, when I cry unto Thee.

Have mercy upon me, and hear me.

After which *preces*, the fifty-first Psalm was said from beginning to end, and three more versicles, which are given at p. 22.

It will be observed that the first of our versicles with its response is not found among the above ferial Suffrages. It was taken from another set which were used on festivals, and is also found at the beginning of a somewhat similar set used every Sunday at the Bidding of Prayers. The Latin form of these latter is as follows :—

Ostende nobis, Domine, misericordiam tuam.

Sacerdotes tui induantur justitiam.

Domine, salvum fac regem.

Salvos fac servos tuos, et ancillas tuas.

Salvum fac populum, Domine, et benedic hereditati tuæ.

Domine, fiat pax in virtute tua.

Domine, exaudi orationem meam.²

The fifth versicle and its response are also different in the existing form. In the ancient Prymer this appears in the following shape, before the Evening Collect for Peace :—

Ant. Lord, þyus pees in oure daies, for there is noon othir that shal fyȝte for us, but thou lord oure god³.

Vers. Lord, pees be maad in thi vertu.

Resp. And plenteousness in thi toures.

The Latin is :—

Da pacem, Domine, in diebus nostris.

Quia non est alius qui pugnet pro nobis nisi tu Deus noster.

² These are given from Maskell's *Monumenta Ritualia*, iii. 343, but the people's responses are omitted. In Chambers' Translation of the Sarum Psalter the complete form has been compiled.

³ Bishop Cosin altered this versicle to a form which was intended to conciliate Puritan objectors, writing "Because there is none other that saveth us from our enemies, but only Thou, O God." The alteration was not approved by the Revision Committee, and was erased.

¹ There is enough analogy between the suffrages of the Western Church and the Ectene or Great Collect of the Eastern, to lead to the conviction that both have a common origin.

¶ *Then the Minister, Clerks, and people, shall say the Lord's Prayer with a loud voice.*

Luke xi. 2—4.

OUR Father, Which art in heaven, Hallowed be Thy Name. Thy kingdom come. Thy will be done in earth, As it is in Heaven. Give us this day our daily bread. And forgive us our trespasses, As we forgive them that trespass against us. And lead us not into temptation: But deliver us from evil. Amen.

¶ *Then the Priest standing up shall say,*

Ps. lxxxv. 7.

O Lord, shew thy mercy upon us.

Answer.

And grant us thy salvation.

Priest.

Ps. xx. 9
[LXX].

° O Lord, save the Queen.

Salisbury Use.

PATER noster, qui es in caelis; sanctificetur nomen tuum: adveniat regnum tuum: fiat voluntas tua, sicut in caelo, et in terra. Panem nostrum quotidianum da nobis hodie: et dimitte nobis debita nostra, sicut et nos dimittimus debitoribus nostris: et ne nos inducas in tentationem: sed libera nos a malo. Amen.

[Ostende nobis, Domine, misericordiam tuam. [From Festival Preces.]

Et salutare tuum da nobis.]

Domine, salvum fac regem.

The sixth versicle and its response are taken from the fifty-first Psalm, which followed the Ferial Preces at Mattins and Vespers.

It will also be observed that the petition for the Sovereign and that for the Ministers of the Church, have exchanged places in the course of their adaptation to modern use. This change first appears at the end of the Litany in Hilsey's Primer of 1539. The reason why the Prayer for the Sovereign is put before that for the Clergy, is, not that the secular power may be honoured above the Church, but that the supreme sovereign authority of the realm may be recognized before the clerical part of the Church¹.

The mutual salutation with which this portion of the daily Office begins, is to be said while the people are yet standing, as they were during the recitation of the Creed; "the Minister first pronouncing" it "with a loud voice," (and turning to the people,) before "all devoutly kneeling," join in the lesser Litany. It is of very ancient ritual use [see Conc. Vas. c. v. A.D. 440], and is believed by the Eastern Church to have been handed down from the Apostles. Its office is to make a transition, in connexion with the lesser Litany, from the service of praise to that of supplication: and also to give devotional recognition to the common work in which Priest and laity are engaged, and the common fellowship in which it is being done. The same salutation is used in the Confirmation Service, after the act of Confirmation, and before the Lord's Prayer: but in this case the lesser Litany is not connected with it. The constant use of this mutual Benediction or Salutation should be a continual reminder to the laity of the position which they occupy in respect to Divine Service: and that, although a separate order of priesthood is essential for the ministration of God's worship, yet there is a priesthood of the laity by right of which they take part in that worship, assuming their full Christian privilege, and making it a full corporate offering of the whole Christian body. Nor should we forget, in connexion with it, the promise "Lo, I am with you always, even to the end of the world."

The lesser Litany is an ancient and Catholic prefix to the Lord's Prayer, which is only used without it in the celebration of the Holy Communion, the Administration of Baptism, and in Confirmation, and at the beginning of Morning and Evening Prayer. In the latter case its omission is supplied by the Confession: in the others the use of the Lord's Prayer is Eucharistic, as will be

shown in the notes appended to it in the Communion Service. In this part of his Prayer Book, Bishop Cosin added the second recitation of each versicle as an "Answer," so as to make the lesser Litany here identical with that in the Litany itself. This probably represents the proper way of using it in Divine Service, as it was thus repeated three times in the Salisbury Use. In its original form this lesser Litany consisted of Kyrie Eleison nine times repeated: but the Western Church has always used Christe Eleison as the second versicle. Its threefold form is analogous to that of the Litany, which opens with separate prayers to each Person of the Blessed Trinity². This form renders it a most fitting introduction to the Lord's Prayer: and the Church has so distinctly adopted the lesser Litany for that purpose, that we may well feel a reverent obligation to use it on all occasions when the Lord's Prayer is said. Such an usage appeals, too, to the instinct of Christian humility, which shrinks from speaking to God even in the words taught us by our Lord, without asking His mercy on our act of prayer, influenced, as it must needs be, by the infirmities of our nature; and imperfect as it must appear to the all-penetrating Eye.

The Lord's Prayer, as used in this place, has a different intention from that with which it was used at the opening of the Service, and is by no means to be looked upon as an accidental repetition arising from the condensation of several shorter services into one longer. In the former place it was used with reference to the Service of Praise and Prayer in which the Church is engaged. Here it is used with reference to the necessities of the Church for the coming day; preceding the detailed prayers of the versicles which follow, and of the Collects which make up the remainder of the Service.

Then the Priest standing up shall say] This Rubric continues the ancient practice, applying it to the whole of the versicles, instead of only to a portion³. The old Rubric after the Miserere, which followed the versicles above given, was "Finito Psalmo solus sacerdos erigat se, et ad gradum chori accedat ad Matutinas et ad Vesperas, tunc dicendo hos versus:—

Exurge, Domine, adjuva nos

Et libera nos propter nomen tuum.

Domine Deus virtutum, converte nos.

Et ostende faciem tuam, et salvi erimus.

¹ The same order is to be found in old formularies: e. g. in the Sacramentary of Grimoldus, printed by Pamelius in his Liturgicon, i. 511, where there is a Benedictio super Regem tempore Synodi, followed by one for the clergy and people.

² The "Mirror" also explains the triple repetition of each Kyrie as a prayer in each case against sins of thought, word, and deed.

³ But, as a general rule, "Preces" were said kneeling (except at Christmas, and from Easter to Trinity), and "Orationes" were said standing.

Answer.

And mercifully hear us when we call upon thee. *

Priest.

Ps. cxxxii. 9. 16. Endue thy ministers with righteousness.

Answer.

And make thy chosen people joyful.

Priest.

Pt. xxviii. 9. O Lord, save thy people.

Answer.

And bless thine inheritance.

Priest.

2 Kings xx. 19. Give peace in our time, O Lord.
Ps. cxxii. 7.

Answer.

Ps. xxix. 11. Because there is none other that
lx. 11. fighteth for us, but only thou, O God.
2 Chron. xxxii. 8.

Priest.

Pt. II. 10, 11. O God, make clean our hearts within us.

Answer.

Gen. vi. 3. And take not thy holy Spirit from
Rom. viii. 9. us.

¶ Then shall follow three Collects; the first of the Day, which shall be the same that is appointed at the Communion; the second for Peace; the third for Grace to live well. And the two last Collects shall never alter, but daily be said at Morning Prayer throughout all the year, as followeth; all kneeling.

¶ The Second Collect, for Peace.

* Ps. lxxviii. 6.
cxxxiii. 1.
1 Cor. xiv. 33.
Matt. v. 9.
John xvii. 3. viii.
32. 36.

O GOD, who art the author of peace and lover of concord, in knowledge of whom standeth our

Et exaudi nos in die qua invocaverimus te. Salisbury Use.

Sacerdotes tui induantur justitiam.

Et sancti tui exultent.

Salvum fac populum tuum, Domine.

Et benedic hereditati tuæ.

[Da pacem, Domine, in diebus nostris. [Antiph. to Collect for Peace.]

Quia non est alius qui pugnet pro nobis nisi tu, Deus noster.]

[Cor mundum crea in me, Domine. [Ps. Miserere mei Deus.]

Et Spiritum sanctum tuum ne auferas a me.]

DEUS auctor pacis et amator, Salisbury Use.
quem nosse vivere: cui servire, Gregor. and Gelas. Missa pro pace.
regnare est; protege ab omnibus im-

Domine, exaudi orationem meam.

Et clamor meus ad te veniat.

Dominus vobiscum.

Et cum spiritu tuo.

Oremus.

[Deinde dicitur Oratio propria .: .]

From this it appears as if the collect, as well as the versicles, were to be said standing; and Bishop Cosin thought this was the meaning of our present Rubric. The intention of the Reformers seems indeed to have been that, throughout the Prayer Book, the Priest should kneel with the people in confessions and penitential prayers, but stand, as in the Communion Office, while offering all other prayers. The standing posture has been almost universally set aside in Morning and Evening Prayer, except during the recitation of these versicles; and its revival would be repugnant to natural feelings of humility. But it was originally ordered as a sign of the authoritative position which the Priest occupied as the representative of the Church; and official gestures ought not to be ruled by personal feeling. At the same time the established usage makes a good ritual distinction between the prayers of the ordinary offices and those of the Eucharistic Service.

The same great truth as to the priesthood of the Laity, which

has already been referred to, is again brought out strongly in the versicle and response, "Endue Thy ministers with righteousness: And make Thy chosen people joyful." It is impossible not to identify the latter words, in their Christian sense, with the words of St. Peter, "But ye are a chosen generation, a royal priesthood, an holy nation, a peculiar people, that ye should show forth the praises of Him who hath called you out of darkness into His marvellous light;" and in a preceding verse of the same chapter, "Ye also, as lively stones, are built up a spiritual house, an holy priesthood, to offer up spiritual sacrifices acceptable to God by Jesus Christ." (1 Pet. ii. 5. 9.) This subject is treated of at greater length in the notes on the Confirmation Service; but the doctrine, or rather the practice of the doctrine, pervades the Prayer Book; the whole system of responsive worship being founded upon it. See also a note on the "Amen" of the Laity at the consecration of the Blessed Sacrament.

THE THREE COLLECTS.

[all kneeling] See the preceding remarks on this posture in the Preces. It is only necessary here to add that the words, "The Priest standing up, and saying, Let us pray. ¶ Then the Collect of the Day," followed those of the present Rubric until

1 John v. 20.
Matt. xi. 29, 30.
* Ps. xviii. 1.
lix. 1. * xxvii.
1, 3. cxviii. c-
9.
Eph. vi. 10-13.
Rom. viii. 31, 35.
37.
Jer. xi. 5 marg.

eternal life, whose service is perfect freedom; defend us thy humble servants in all assaults of our enemies; that we surely trusting in thy defence, may not fear the power of any adversaries, through the might of Jesus Christ our Lord. *Amen.*

† *The Third Collect, for Grace.*

Isa. lxiv. 8.
Matt. vi. 9.
Hab. i. 12.
Rev. xi. 17.
Lam. iii. 22, 23.
Ps. iii. 3.

O LORD, our heavenly Father, Almighty and everlasting God, who hast safely brought us to the be-

pugnationibus supplices tuos; ut qui in defensione tua confidemus, nullius hostilitatis arma timeamus. Per Jesum Christum Dominum nostrum. *Amen.*

Cf. Seneca de Vita beatâ, c. xv., "Deo parere, libertas est."

DOMINE sancte, Pater omnipotens, æterne Deus, qui nos ad principium hujus diei pervenire fecisti;

Salisbury Use. Greg. Orationes ad Matutinas.

1552, representing the old usage of the Church. As this direction was thrown further back, and no direction for the Priest to kneel inserted in its place here, the Rubric appears to order the same posture at the versicles and the collects, as has been already shown.

§ *The First Collect, of the Day.*

The central point of all Divine Worship, towards which all other services gravitate, and around which they revolve, like planets round a sun, is the great sacrificial act of the Church, the offering of the Holy Sacrament. The ordinary services of Mattins and Evensong are therefore connected with it ritually by the use of the collect "that is appointed at the Communion," to which precedence is given over all other prayers except the Lord's Prayer, and the versicles from Holy Scripture. This collect is the only variable prayer of the Communion Office, and it is almost always built up out of the ideas contained in the Epistle and Gospel appointed for the Sunday or other Holyday to which it specially belongs; these latter, again [see Introduction to Collects, &c.], being selections of most venerable antiquity, intended to set a definite and distinctive mark on the day with which they are associated. Thus the first collect of Morning and Evening Prayer fulfils a twofold office. First, it connects those services with the great act of sacrificial worship which the Church intends to be offered on every Sunday and Holyday (at least) to her Lord; and, secondly, it strikes the memorial key-note of the season, linking on the daily services to that particular phase of our Blessed Lord's Person or Work which has been offered to our devotion in the Gospel and Epistle. And as all Divine Worship looks first and principally towards Him to Whom it is offered, so it must be considered that these orderly variations of the collect are not ordained chiefly as a means of directing the tone of thought and meditation with which the worshippers approach Him; but as a devotional recognition and memorial before God of the change of times and seasons which He Himself has ordained both in the natural and the spiritual world. "He hath appointed the moon for certain seasons, and the sun knoweth his going down." So the division of our time from week to week has been marked out by the Divine Hand in the rest of the Creation Sabbath and the triumph of the Resurrection Sunday; and each week of the year is also distinguished by the Church with some special reference to acts or teachings of her Divine Master, which she commemorates day by day at Mattins and Evensong, as well as at her chief service of the week.

The following rules will be found practically useful as regards the use of the first collect, and for convenience those relating to Evensong are included, as well as those more properly belonging to this page:—

1. The Sunday Collect is to be said from the Saturday evening before to the Saturday morning after, inclusive.
2. Festival Collects are invariably to be used on the evening before the festival, whether it is kept as a vigil or not. When the vigil is kept on a Saturday, the festival being on the Monday following, the collect of the latter need not be said on Saturday evening; but on Sunday evening it should be said before the Sunday collect.

3. The Sunday collect is ordinarily superseded by the collect of any festival which occurs on the Sunday.

4. But if any festival occurs on any of the following Sundays, both collects should be used, that for the Sunday being said first.

Advent Sunday.	5th Sunday in Lent.
Septuagesima Sunday.	6th " "
Sexagesima Sunday.	Easter Day.
Quinquagesima Sunday.	Sunday after Easter.
4th Sunday in Advent.	Whit-Sunday.
1st Sunday in Lent.	Trinity Sunday.

The same rule is applicable to Ash-Wednesday, Maundy Thursday, Good Friday, Easter Even, and Ascension Day.

But on other week-days following the above Sundays, a Festival Collect should take precedence of the Sunday Collect, as the collects of the three days after Christmas take precedence of that of Christmas Day.

5. The following are special usages connected with several days and seasons:—

The Collect for	Advent Sunday is to be used until the morning of Dec. 24	inclusive.
	Christmas Day " " " Dec. 31	
	Circumcision " " " Jan. 5	
	Epiphany " " " Saturday	
	Quinquagesima " " evening of Tuesday	
	Ash-Wednesday [alone] " morning of Saturday	
	" " " is to be used after all others until the morning of the Saturday before Easter Day	
Ascension Day " " until the morning of Saturday		

§ *The Second Collect, for Peace.*

This beautiful prayer is translated from one which was used at Lauds in the ancient services, and was also the Post-Communion of a special Eucharistic office on the subject of peace. It appears in the Sacramentaries of Gelasius and Gregory the Great, and has probably been in use among us ever since the time of the latter, more than twelve centuries and a half.

It must be taken as a prayer for the peace of the Church Militant, even more than as one for that of the Christian warrior: a devout acknowledgment in the case of both that the events of every day are ruled by the Providence of Almighty God, Who doth according to His will in the army of Heaven, and among the inhabitants of the earth; and none can stay His hand, or say unto Him, "What doest Thou?" The beautiful and terse expression, "Whose service is perfect freedom" (though inferior to the "whom to serve is to reign" of the Latin), is a daily reminder to us of our position as soldiers of Christ, bound to Him as those who have vowed to "continue His faithful soldiers and servants unto their lives' end," but yet bound by the yoke of a loving Captain, whose object is to save us from the slavery of sin and carry us on to the eternal freedom of Heaven. There is a mixture of humility and confidence in this Collect, which fits it well for the lips of those who are faithfully endeavouring to do their duty day by day. They "seek peace and pursue it," yet know that spiritual enemies are ever on the watch to assault them: they know their danger, yet have no fear for the end

Ps. xciv. 22.
cvi. 8. xvii. 5.
8. cxix. 133.
cxxi. 8.
Matt. vi. 13.

gining of this day; defend us in the same with thy mighty power, and grant that this day we fall into no sin, neither run into any kind of danger; but that all our doings may be ordered by thy governance, to do always that is righteous in thy sight, through Jesus Christ our Lord. *Amen.*

Prov. iii. 5. 23.
25.
Ps. cxliii. 8. 10.
xxxvii. 23.
Heb. xiii. 20, 21.
Eph. ii. 18.

Ps. xxx. 4.
lxvi. 1.

¶ *In Quires and Places where they sing, here followeth the Anthem.*

¶ *Then these five Prayers following are to be read here, except when the Litany is read; and then only the two last are to be read, as they are there placed.*

¶ *A Prayer for the Queen's Majesty.*

1 Tim. ii. 1. vi.
15.
Ps. xlviii. 2.
Rev. xix. 16.

O LORD our heavenly Father, high and mighty, King of kings, Lord of lords, the only Ruler of princes,

tua nos hodie salva virtute; et concede Salisbury Use. ut in hac die ad nullum declinemus peccatum; nec ullum incurramus periculum, sed semper ad tuam justitiam faciendam omnis nostra actio tuo moderamine dirigatur. Per Jesum Christum Dominum nostrum. Amen.

O LORDE Jesu Christe, moste Book of Private Prayers, 1545-8, and Prymer, 1553. high, most mightie kyng of kynges, lorde of lordes, the onely ruler

while the might of Him Who "goes forth conquering and to conquer" is given for their defence: of Him Who can say to the troubled waves around the ark of His Church, "Peace, be still."

§ *The Third Collect, for Grace.*

This Collect occupied a similar position in the Prime office of the ancient use of the Church of England as it does in our present Morning Prayer. It is found in Menard's edition of Gregory the Great's Sacramentary, among the Oraciones ad Matutinas Incescente die; and is, therefore, of as venerable an antiquity as the preceding one. It will be interesting to notice the difference between the old English use given above, the Roman use, and the ancient form in which the Collect appears in the Sacramentary of St. Gregory.

Gregorian.

Deus, qui nos ad principium hujus diei pervenire fecisti, da nobis hunc diem sine peccato transire; ut in nullo a tuis semitis declinemus; sed ad tuam justitiam faciendam nostra semper procedant eloquia. Per.

Roman.

Domine Deus omnipotens, qui ad principium hujus diei nos pervenire fecisti; tua nos hodie salva virtute, ut in hac die ad nullum declinemus peccatum, sed semper ad tuam justitiam faciendam nostra procedant eloquia, dirigantur cogitationes et opera. Per Dominum.

The Roman was the same both before and after the reform of the Breviary: and the difference between it and our own shows the independent character of the English rite; furnishing evidence also that our own reformers used the Salisbury, and not the Roman Breviary, for their translations.

One of the prayers in the Morning Office of St. Basil also bears considerable resemblance to the Collect for Grace, sufficient to indicate a common origin. It is thus given by Archdeacon Freeman, in his "Principles of Divine Service," i. 222:—

Ὁ Θεὸς ὁ αἰώνιος, τὸ ἀναρχὸν καὶ ἀίδιον (Ps. xc. 1.)
χάριται ἡμῶν ἐν τῇ παρουσίᾳ ἡμέρᾳ εὐαρεστῆν σοι, διαφυλάττων ἡμᾶς ἀπὸ πάσης ἀμαρτίας καὶ πάσης πονηρᾶς πράξεως, βυόμενος ἡμᾶς ἀπὸ βέλους πετομένου ἡμέρας καὶ πάσης ἀντικειμένης δυνάμεως.

(From Second Prayer):—

τὰ τῶν χειρῶν ἡμῶν ἔργα, πράττειν ἡμᾶς τὰ σοι εὐάρεστα καὶ φίλα, εὐδόξως.

This Collect was placed here as the end of Mattins in 1549, a most appropriate prayer with which to go forth to the work which each one has to do. In the rubric it is called a prayer "for grace to live well," and Bishop Cosin wished to insert this

full title above the collect as a sign of the object for which it is offered. In a few terse words it recognizes the dependence of all for spiritual strength on the grace of God, our position in the midst of temptations to sin, and the power to do good works well pleasing to God when our doings are under His governance. As a prayer bearing on the daily life of the Christian, it may be taken as a devotional parallel to the well-known axiomatic definition of Christian practice, that it is "to do my duty in that state of life to which it shall please God to call me."

The rubrics which follow the three Collects are of more importance than they have usually been considered. The first directs that "¶ In Quires and places where they sing, here followeth the Anthem." The Anthem itself is spoken of at length in another place. All that is necessary to mention here in connexion with it is, that (1) although this rubric was not in the Prayer Book in the time of Queen Elizabeth, there is historical evidence of an Anthem being sung at the conclusion of the Service, of which our modern organ voluntary is probably a traditional relic: and (2) that Anthems were clearly not contemplated, except in "Quires and places where they sing," Cathedrals, Royal Chapels, Collegiate Churches, &c.

This gives considerable force to the word "Then" in the following Rubric, "¶ Then these five Prayers following are to be used," &c.; for it is clear that, the two Rubrics being placed where they are at the same time, the "Then" of the second derives its meaning entirely from the words which immediately precede it in the first Rubric.

From this the conclusion may be drawn that where an Anthem does not follow the third Collect, the five remaining prayers are not to be said, but the Morning Prayer terminated (as it was for a hundred years after the Reformation, by express rule) at the third Collect. This view of the second Rubric is confirmed by the "as they are there placed" which concludes it.

An explanation of such an usage may be found in the difference of position between ordinary parish churches and the churches defined by the expression, "Quires and places where they sing." The latter are of a more representative character than the former, and usually in a more public situation; and in these, the daily commemoration of the Sovereign, the Royal Family, and the Clergy becomes a public duty, in a higher degree than in village churches, or others where the service is usually of a more humble character.

Where the length of Morning and Evening Prayer is therefore an obstacle to the use of *Daily Service*, this Rubric provides (accidentally, perhaps, yet effectually) for the difficulty; and shows that there is an elasticity about the Prayer Book, here, as

Ps. xxxiii. 13-15.
Prov. xv. 3.
Col. iii. 23.
Prov. xxi. 1.
Ps. lxxxiv. 9.

Acts viii. 15.
Luke xi. 13.
1 Chron. xxii. 12.
2 Cor. ix. 8.
1 Kings iii. 9.
James i. 17.

Ps. lxxii. 1, 2.

1 Chron. xxix.
12. 28.

2 Chron. i. 11, 12.

Ps. xx. 1, 2.
xviii. 37, 39, 43.
xxi. 1, 5, 6.

2 Tim. iv. 8.

1 Pet. v. 10.

who dost from thy throne behold all the dwellers upon earth; most heartily we beseech thee with thy favour to behold our most gracious Sovereign Lady Queen *VICTORIA*, and so replenish her with the grace of thy Holy Spirit, that she may alway incline to thy will, and walk in thy way: Endue her plenteously with heavenly gifts, grant her in health and wealth long to live, strengthen her that she may vanquish and overcome all her enemies; and finally after this life, she may attain everlasting joy and felicity, through Jesus Christ our Lord. *Amen.*

of princes, the very sonne of god, on whose ryghte hande syttyng, docest from thy throne beholde all the dwellers upon earth: with mooste lowly hertes we beseeche the, vouchesafe with fauourable regard to behold our most gracious soueraigne lorde Kyng Edwarde the syxte, and so replenysshe hym with the grace of thy holy spirite, that he alway incline to thy wil, and walke in thy way. Kepe hym farre of from ignoraunce, but through thy gifte, leat prudence and knowlage alwaie abound in his royall hert. So instructe hym (o Lord iesv), reygnyng upon us in erth, that his humaine majestee, alway obey thy divine majestee in feare and drede. Indue him plentifully with heavenly geftes. Grant him in health and welth long to liue. Heape glorie and honoure upon hym. Glad hym with the joye of thy countenance. So strengthe hym, that he maie vanquish and overcome all his and our foes, and be dread and feared of al the enemies of his realme. [And finally, after this life, that he may attain everlasting joy and felicity. *Prymer Version.*] *Amen*¹.

elsewhere, which makes it capable of meeting the varied requirements of social life. Perhaps the idea of an universal Daily Mattins and Evensong was dying out when the additions were made to the beginning and the end of the Services, or a more distinct Rubrical provision would have been made, limiting their general use to particular churches on week-days, and ordering it for all on Sundays.

THE FIVE PRAYERS.

These prayers were inserted in this place in 1661, apparently at the suggestion of Bishop Cosin made in his Amended Prayer Book. Some of them had been previously in use in the Litany or in Occasional Offices. To a certain extent they represent some private prayers used by the Clergy, after the public Office was over in the ancient system of the Church [Freeman, i. 371]; but this parallel is accidental, as an interval of more than a century had elapsed between the cessation of the old custom, and its revival in the present form. There are, however, several pages of "*Memoria Communes*" in the Salisbury Missals, and among these may be found the original idea, though not the *ipsissima verba*, of the four intercessory prayers here used, and also of several of those called "Occasional." The *Memoria Communes* were, in fact, "Prayers and Thanksgivings upon Several Occasions;" and the four intercessory prayers now used daily seem to have been originally considered as belonging to this class. It is noticeable that the ancient structural form of the Collect [see Introduction to Collects, &c.] has been carefully adopted in these prayers, as it was in the case of the daily Absolution.

§ *The Prayer for the Queen.*

This occurs first in two books of Private Prayers, the one entitled "Psalmes or Prayers taken out of Holy Scripture" (1545-1548), the other, "Prayers or Meditations . . . collected out of holy works by the most virtuous and gracious Princess

Katherine, Queen of England, France, and Ireland. Anno dni 1547." It was also inserted in the Morning Prayer, printed in the Prymer of 1553, as the "Fourth Collect." In Queen Elizabeth's reign (1559) it was placed with other prayers and in its present shape, before the Prayer of St. Chrysostom at the end of the Litany. Our present usage was first adopted in the Form of Prayer for March 24, 1604, commemorating the entry of James I. into England. It was inserted in the Scottish Prayer Book of 1637, and finally settled as we now have it in 1661.

It is not known who was the author of this fine composition, the opening of which is equal in grandeur to any thing of the kind in the ancient Liturgies; breathing indeed the spirit of the *Tersanctus* and *Trisagion*.

A prayer for the Sovereign is a very ancient part of Divine Service, the Apostolic use of it being evidenced beyond doubt by the words of St. Paul, in the opening of the second chapter of his First Epistle to Timothy, "I exhort therefore that, first of all, supplications, prayers, intercessions, and giving of thanks, be made for all men: for kings, and for all that are in authority; that we may lead a quiet and peaceable life in all godliness and honesty." The "giving of thanks" being simply an expression for the offering of the Holy Eucharist, this injunction ought to

¹ The final clause of this prayer is taken from the Post-Communion of a *Missæ Quotidiana pro Rege* in the Sacramentary of St. Gregory, which is as follows:—

"*Hæc, Domine, oratio salutaris famulum tuum, Ill., ab omnibus tueatur adversis, quatenus et Ecclesiasticæ pacis obtineat tranquillitatem, et post istius temporis decursum ad æternam perveniat hereditatem. Per.*" [Greg. Miss. Quotid. pro Rege. Ad Complendum.]

The earlier part of it bears some resemblance to the beginning of the *Consecratio Regis*, printed at p. 279 in the Appendix to Menard's Sacramentary of St. Gregory. "Omnipotens sempiternus Deus, Creator et Governator cœli et terræ, Conditor et Dispositor Angelorum et hominum, Rex regum et Dominus dominorum, qui . . ." &c.

¶ *A Prayer for the Royal Family.*

Job xlii. 2.
Ps. xxxvi. 9.
lxxii. 1.
2 Sam. vii. 29.
1 Chron. xxviii. 9.
1 Sam. xvi. 13, 14.
Isa. xlv. 3.

Rev. iii. 18.
2 Sam. vii. 12—16.
23. 26.
2 Tim. iv. 18.
2 Pet. i. 11.

ALMIGHTY God, the fountain of all goodness, we humbly beseech thee to bless *Albert Edward* Prince of *Wales*, the Princess of *Wales*, and all the Royal Family: Endue them with thy holy Spirit; enrich them with thy heavenly grace; prosper them with all happiness; and bring them to thine everlasting kingdom; through Jesus Christ our Lord. *Amen.*

¶ *A Prayer for the Clergy and People.*

Ps. xc. 2. lxxii.
18. cxxxvi. 3, 4.
Acts ii. 1—7. 11.
Eph. iv. 11—13.
Acts ii. 17. 41—47.

ALMIGHTY and everlasting God, who alone workest great marvels; Send down upon our Bishops,

ALMIGHTY God, which hast promised to be a Father of thine Elect, and of their seed: We humbly beseech thee to bless our Noble Prince Charles, Fredericke the Prince Elector Palatine, and the lady Elisabeth his wife: endue them with thy holy Spirit, enrich them with thy heavenly grace, prosper them with all happinesse, and bring them to thine everlasting kingdome, through Jesus Christ our Lord. *Amen.*

Common Prayer
Book of 1604.

OMNIPOTENS sempiternus Deus, qui facis mirabilia magna solus: prætende super famulos tuos Pontifices

Salisbury Use.
Greg. Missa pro
Episcopo vel
congregatione.
Gelas.

be taken as containing a reference to the use of such an intercession at the ordinary prayers of the Church, as well as at the Holy Communion. A *Missa pro Rege* is contained in the Sacramentary of St. Gregory, as has been shown, as early as the sixth century. In the ecclesiastical laws of King Ethelred, A.D. 1012, the third chapter contains express directions that a certain prayer should be said daily for the king and his people; and the practice of the Church of England before the Reformation has already been mentioned.

It may be useful to place in connexion with our now familiar Prayer for the Sovereign, one from an Eastern Liturgy, and the Memorial of the Salisbury Breviary.

From the Liturgy of St. Mark.

“O Lord, Master and God, the Father of our Lord and Saviour Jesus Christ; we beseech Thee to preserve our king in peace, might, and righteousness. Subdue under him, O God, his foes and all that hate him. Lay hold upon the shield and buckler, and stand up to help him. Grant victories unto him, O God, and that he may be peaceably disposed both towards us and towards Thy holy Name; and that we also, in the peace of his days, may lead a quiet and peaceable life, in all godliness and honesty, through the grace, mercy, and loving-kindness of Thine only begotten Son; through Whom, and with Whom, be glory and power unto Thee, with Thine all-holy, good, and life-giving Spirit, now and for ever, and unto all eternity. Amen.”

MEMORIE PRO REGE ET REGINA.

(From the *Salisbury Missal*.)

Oratio.

“Deus in cujus manu sunt corda regum: qui es humilium Consolator, et fidelium Fortitudo, et Protector omnium in Te sperantium: da regi nostro ꝑ. et reginæ nostræ ꝑ. populoque Christiano triumphum virtutis tuæ scienter excolere: ut per Te semper reparentur ad veniam. Per Dominum.

Secreta.

“Suscipe, quæsumus, Domine, preces et hostias ecclesiæ tuæ, quas pro salute famuli Tui regis nostri et reginæ et protectione fidelium populorum Tuæ Majestati offerimus: supplicantes ut antiqua brachii tui Te operante miracula, superatis inimicis, secura tibi serviat Christianorum libertas. Per Dominum.

Post-Communio.

“Præsta, quæsumus, Omnipotens Deus: ut per hæc mysteria sancta quæ sumpsimus, rex noster et regina, populusque Christianus semper rationabilia meditates: quæ tibi placita sunt, et dietis exequantur et factis. Per Dominum.”

These are taken from a Missal of 1514; another set, mention-

ing the name of Henry VIII., are given by Mr. Maskell in his *Ancient Liturgy*, p. 184. The Post-Communion of the latter ends with the words “et post hujus vitæ decursum ad æternam beatitudinem, tua gratia cooperante, perveniat;” which are evidently the original of “And finally after this life, she may attain everlasting joy and felicity.” See also the preceding foot-note.

§ *The Prayer for the Royal Family.*

This was placed among the prayers at the end of the Litany in 1604, by James I. The expression “the fountain of all goodness” was substituted, in 1625 (in the first Form of Occasional Prayers issued under Charles I.), for the strong expression used in the opening of it under James. The following letter, copied from Bishop Cosin’s MSS., led to its final adoption in its present form, and serves to illustrate its introduction into the Daily Service:—

“Charles R.

“Our will and pleasure is that you forthwith cause this ensuing Collect for our Royall Consort to be used in all churches and chappels within your province, instead of that which is now used for the Royall Progeny. For which this shall be your warrant. Given at our Court at Whitehall this 8th day of November, 1661.

[Then follows the Collect.]

“To our right trusty and right well beloved, the Most Reverend Father in God Accepted, Lord Archbishop of York.

“By His Majestie’s Command,
“EDWARD NICHOLAS.”

In this and other prayers for the Sovereign and the Royal Family, the necessary changes are made by Royal Proclamation, under the following clause in the Act of Uniformity:—“Provided always, and be it further enacted by the authority aforesaid, that in all those Prayers, Litanies, and Collects which do any way relate to the King, Queen, or Royal Progeny, the Names be altered and changed from time to time, and fitted to the present occasion, according to the direction of lawful authority.” What the lawful authority is does not clearly appear; but against the clause in the Litany, and also against this Prayer, there is a marginal note in Cosin’s book, “Such only are to be named as the King shall appoint.”

§ *The Prayer for the Clergy and People.*

This Collect is very ancient, being found in the Sacramentary of Gelasius. It is also in all the English Prymers, and a version of it, as it stood in the fourteenth century, is given in *Evening Prayer*. It was placed at the end of the first authorized English

Tit. iii. 5, 6.
2 Cor. ix. 8.
Deut. xxxiii. 28.
Ps. cxxxiii. 3.
Eph. i. 3. iv. 8.
1 John ii. 1.
1 Tim. ii. 5.

and Curates, and all Congregations committed to their charge, the healthful Spirit of thy grace; and that they may truly please thee, pour upon them the continual dew of thy blessing. Grant this, O Lord, for the honour of our Advocate and Mediator, Jesus Christ. *Amen.*

¶ *A Prayer of Saint Chrysostom.*

Isa. ix. 6.
Ps. x. 17.
Acts i. 14. iv. 24.
Eph. vi. 18.
Matt. xviii. 19, 20.
Acts xii. 12.
Exod. xx. 24.
Isa. lvi. 7.
Ps. xx. 1. 4, 5.
cxiv. 18, 19.
1 John v. 14, 15.
Matt. vi. 33.
1 Tim. ii. 3, 4.
John x. 27, 28.
Jer. xi. 5, margin.

ALMIGHTY God, who hast given us grace at this time with one accord to make our common supplications unto thee, and dost promise, that when two or three are gathered together in thy Name, thou wilt grant their requests; Fulfil now, O Lord, the desires and petitions of thy servants, as may be most expedient for them; granting us in this world knowledge of thy truth, and in the world to come life everlasting. *Amen.*

2 Cor. xiii.

THE grace of our Lord Jesus Christ, and the love of God, and the fellowship of the Holy Ghost, be with us all evermore. *Amen.*

Here endeth the Order of Morning Prayer throughout the Year.

et super cunctas congregationes illis commissas Spiritum gratiæ salutaris; et ut in veritate tibi complacent, perpetuum eis rorem tuæ benedictionis infunde.

Ὁ τὰς κοινὰς ταύτας καὶ συμφώνους ἡμῖν χαρισάμενος προσευχὰς, ὁ καὶ δύο καὶ τρισὶ συμφωνοῦσιν ἐπὶ τῷ ὀνόματί σου τὰς αἰτήσεις παρέχειν ἐπαγγελιάμενος· αὐτὸς καὶ νῦν τῶν δούλων σου τὰ αἰτήματα πρὸς τὸ συμφέρον πλήρωσον, χωρηγῶν ἡμῖν ἐν τῷ παρόντι αἰῶνι τὴν ἐπίγνωσιν τῆς σῆς ἀληθείας, καὶ ἐν τῷ μέλλοντι ζωῆν αἰώνιον χαριζόμενος.

Liturgies of St. Chrysostom and St. Basil.

Capitulum: ii. Cor. ultimo.

GRATIA Domini nostri Jesu Christi, et charitas Dei, et communicatio Sancti Spiritus sit semper cum omnibus nobis.

Litany in 1544, and where it now is in 1661. Bishop Cosin wished to meet Puritan objectors by altering it as follows:—

¶ *A Prayer for the Clergy and their Charge.*

“Almighty and Everlasting God, who didst pour out upon Thy Apostles the great and marvellous gift of the Holy Ghost, send down upon our Bishops, the Pastors of Thy Church, and such others as have cure of souls under them, together with all congregations committed to their charge”

It was also suggested by him to use the phrase “from whom all spiritual graces do proceed,” which is nearly that adopted in the American Prayer Book; but both changes were rejected by the Revision Committee. “People” was also substituted for “their charge,” perhaps to make the title more comprehensive.

The word “Curates” was objected to at the Savoy Conference, when the Bishops and other Clergy replied, “The word *Curate* signifying properly all those who are trusted by the Bishops with Cure of souls, as anciently it signified, is a very fit word to be used, and can offend no sober persons.”

§ *A Prayer of St. Chrysostom.*

The introduction of this beautiful collect into the Prayer Book by the Reformers, shows that they were not unacquainted with the Greek Liturgies, if they had thought it expedient to draw upon them more freely than they did. It never had a place in any European Ritual until 1544, when it was placed at the end of the English Litany which had been revised and set forth by Archbishop Cranmer and his coadjutors as a first-fruits of their work.

The prayer is found in the Liturgies of St. Basil and St. Chrysostom, but its present position at the end of a Service is a happy novelty. It was ordered to be so used in the Scotch Prayer Book of 1637, and inserted in the English Revisal of 1661.

¹ Grand Debate between the Bishops and the Presbyterian Divines, 1661, p. 79. Cardwell's Conf. p. 342.

§ *The Benediction.*

This benediction of priest and people by the former is translated from the Capitulum which was used at Tierce (the nine o'clock Morning Service) in the ancient Church of England, and was first inserted after the Litany in 1559. It also begins the Anaphora of the three great Oriental Liturgies of St. Chrysostom, St. Basil, and St. James, being followed by the versicle, “And with thy Spirit,” and the *Sursum Corda*. In the two former, the benedictory form appears as it is in 2 Cor. xiii. 14, “be with you all,” but in that of St. James it is in the form “be with us all,” as in our own and in the ancient Tierce Service. As the Vulgate also has “sit cum omnibus vobis,” it is improbable that the ancient Capitulum was taken from it, especially since the word “semper” is no more represented there than it is in the Greek of the New Testament; the two being as follows:—

Ἡ χάρις τοῦ Κυρίου Ἰησοῦ Χριστοῦ, καὶ ἡ ἀγάπη τοῦ Θεοῦ, καὶ ἡ κοινωνία τοῦ ἁγίου πνεύματος μετὰ πάντων ὑμῶν. ἀμήν.
Gratia Domini nostri Jesu Christi, et charitas Dei, et communicatio Sancti Spiritus sit cum omnibus vobis. Amen.

There is some probability, from these peculiarities, that this benediction gives us a lingering trace of prayers more anciently used in England than the time of St. Osmund. In St. James's Liturgy, the benediction is, “The love of the Lord and Father, the grace of the Lord and Son, the communion and gift of the Holy Ghost, be with us all;” and although this is still more different from our form than the Bible version, the “us” instead of “you” is (under the circumstances) so very distinctive, as to lead to the impression that it represents a Liturgy not now extant, which was analogous to that of St. James. It has also been suggested that this was originally a Liturgical benediction, and was adopted, as many other Liturgical expressions were, by St. Paul. No doubt its use as a Blessing in Divine Service is of primitive antiquity.

THE
ORDER
FOR
EVENING PRAYER,
DAILY THROUGHOUT THE YEAR.

¶ *At the beginning of Evening Prayer the Minister shall read with a loud voice some one or more of these Sentences of the Scriptures, that follow. And then he shall say that which is written after the said Sentences.*

Ezek. xviii. 27. **W**HEN the wicked man turneth away from his wickedness, that he hath committed, and doeth that which is lawful and right, he shall save his soul alive.

Ps. li. 3. I acknowledge my transgressions, and my sin is ever before me.

Ps. li. 9. Hide thy face from my sins, and blot out mine iniquities.

Ps. li. 17. The Sacrifices of God are a broken spirit: a broken and a contrite heart, O God, thou wilt not despise.

Joel ii. 13. Rend your hearts, and not your garments, and turn unto the Lord your God: for he is gracious and merciful, slow to anger, and of great kindness, and repenteth him of the evil.

Dan. ix. 9, 10. To the Lord our God belong mercies and forgivenesses, though we have rebelled against him: neither have we obeyed the voice of the Lord our God, to walk in his laws, which he set before us.

Jer. x. 24.
Ps. vi. 1. O Lord, correct me, but with judgement; not in thine anger, lest thou bring me to nothing.

Matt. iii. 2. Repent ye; for the Kingdom of Heaven is at hand.

Luke xv. 18, 19. I will arise and go to my Father, and will say unto him; Father, I have

sinned against Heaven, and before thee, and am no more worthy to be called thy son.

Enter not into judgement with thy servant, O Lord; for in thy sight shall no man living be justified. *Ps. cxliii. 2.*

If we say that we have no sin, we deceive ourselves, and the truth is not in us. But, if we confess our sins, he is faithful and just to forgive us our sins, and to cleanse us from all unrighteousness. *1 John i. 8, 9*

DEARLY beloved brethren, the Scripture moveth us in sundry places to acknowledge and confess our manifold sins and wickedness, and that we should not dissemble nor cloak them before the face of Almighty God our heavenly Father, but confess them with an humble, lowly, penitent, and obedient heart, to the end that we may obtain forgiveness of the same, by his infinite goodness and mercy. And although we ought at all times humbly to acknowledge our sins before God, yet ought we most chiefly so to do, when we assemble and meet together, to render thanks for the great benefits that we have received at his hands, to set forth his most worthy praise, to hear his most holy word, and to ask those things which are requisite and necessary, as well for the body as the soul. Wherefore I pray and beseech

The Order for Evening Prayer.] The Evening Service of the Book of Common Prayer was formed out of the two Evening Services, Vespers and Compline, of the ancient Order; a fixed form being, however, substituted for variable ones, and the hymns being left to the discretion of the Clergy.

Nothing further need be said here respecting those parts of the daily Offices which have been already commented upon under Morning Prayer, but some additional illustrations are given in the shape of ancient English versions of various parts of the services. These are inserted within brackets when they are placed

you, as many as are here present, to accompany me with a pure heart and humble voice unto the throne of the heavenly grace, saying after me.

¶ *A general Confession to be said of the whole Congregation after the Minister, all kneeling.*

ALMIGHTY and most merciful Father; We have erred and strayed from thy ways like lost sheep. We have followed too much the devices and desires of our own hearts. We have offended against thy holy laws. We have left undone those things which we ought to have done; And we have done those things which we ought not to have done; And there is no health in us. But thou, O Lord, have mercy upon us, miserable offenders. Spare thou them, O God, which confess their faults. Restore thou them that are penitent; According to thy promises declared unto mankind in Christ Jesu our Lord. And grant, O most merciful Father, for his sake; That we may hereafter

live a godly, righteous, and sober life, To the glory of thy holy Name. Amen.

¶ *The Absolution or Remission of sins to be pronounced by the Priest alone, standing; the people still kneeling.*

ALMIGHTY God, the Father of our Lord Jesus Christ, who desireth not the death of a sinner, but rather that he may turn from his wickedness, and live; and hath given power and commandment to his Ministers, to declare and pronounce to his people, being penitent, the absolution and remission of their sins: He pardoneth and absolveth all them that truly repent, and unfeignedly believe his holy Gospel. Wherefore beseech we him to grant us true repentance, and his holy Spirit, that those things may please him, which we do at this present; and that the rest of our life hereafter may be pure and holy, so that at the last we may come to his eternal joy, through Jesus Christ our Lord. *Amen.*

¶ *Then the Minister shall kneel, and say the Lord's Prayer; the people also kneeling, and repeating it with him.*

OUR Father, which art in heaven, Hallowed be thy Name. Thy kingdom come. Thy will be done in earth, As it is in heaven. Give us this day our daily bread. And forgive us our trespasses, As we forgive them, that trespass against us. And lead us not into temptation; But deliver us from evil: For thine is the kingdom, the power, and the glory, For ever and ever. Amen.

"And," see Morning Prayer.

[Here begynneth the pater noster.

Prymer Version of XIVth century.

OURE fadir, that art in heuenes, halewid be thi name: thy rewme come to thee: be thi wille do as in heuene and in erthe: oure eche daies breed þyue us to day: and forþyue us oure dettis, as and we forþeuen to oure dettouris: and ne lede us into temptacioun: but delyuere us fro yuel. So be it.]

beside the text of the Prayer Book: and it must be understood that they are verbal illustrations only, not always coming from an office similar to that in which they are now printed. The opening versicles of the Service, for example, are taken from the Mattins of the Ancient Prymer: at the later services of the day the two first do not appear; and at Compline they are replaced by "Turn us O God of our salvation. And let Thine anger cease from us." These in the Prymer are "God our salvacion converte us to Thee. And turne fro us Thy wrathe."

Evening Prayer began with the Lord's Prayer and ended with the third Collect, from its first translation in 1549 until 1661. In the Rubric, before the sentences at Morning Prayer, the Minister was directed (from 1552 onwards) to say them and that which follows "at the beginning both of Morning and Evening Prayer:" but the Puritan criticisms of the Prayer Book and the Clergy

show that this was rarely, if ever, the practice until the last Revision, when the two Services were made alike in this respect.

THE LORD'S PRAYER.

The above is a version of the Lord's Prayer as it was used by the people in their daily services, when the prayers of the Church were still said in Latin, about the end of the fourteenth century. Some earlier versions are here given, which may be taken as representatives of those translations into the vulgar tongue which were so frequently directed in provincial and diocesan constitutions. There cannot be a doubt that the Lord's Prayer was as familiar to the people of England in ancient days as it is at present.

The first among the following ancient forms of it is taken from

¶ *Then likewise he shall say,*

O Lord, open thou our lips.

Answer.

And our mouth shall shew forth
thy praise.

Priest.

O God, make speed to save us.

Answer.

O Lord, make haste to help us.

¶ *Here all standing up, the Priest shall say,*

Glory be to the Father, and to the
Son : and to the Holy Ghost ;

[*Domine, Labia.*

Lord, thou schalt opyne myn lippis.

*Prymer Version
of XIVth cen-
tury.*

And my mouth schal schewe thi
prisung.

God, take heede to myn help :

Lord, hiȝe thee to helpe me.

i. e. "hie."

Glorie be to the fadir and to the
sone and to the holy goost :

a gloss on the Evangelists, written by Eadfrid, Bishop of Lindisfarne, about A.D. 700. [Cotton MS. Nero D. iv.]

Fader usser thu arth in Heofnas sie gehalgad noma thin to cymeth ric thin. siȝ willo thin swa is in Heofne and in Eorþo. Hlaf userne oferwistlic sel us to dæg, and forgef us scyltha usra swa use forgefon scylgum usum. And ne inlead usith in costnunge. Ah gefrig usich from yfle.

The next is from Saxon homilies of about the same date :

Fader ure thu the in heofnum earth, beo gehalgud thin noma. Cume to thin rice, weorthe thin willa swa swa on Heofune swile on eorthe. Hlaf userne doeghwamlican sel us to dæg, and forlete us ure scyldre, swa swa we ac forleten thaem the scyldigat with us, no geleade in costnunge. Ah gelefe us of yfle.

The next is from a MS. in the Library of Caius College, Cambridge, belonging to the thirteenth century, and printed by Mr. Maskell in the Appendix to his Fourteenth Century Prymer, Monumenta Ritualia, ii. 238 :

Fader oure that art in heve, i-halgeed bee thi nome, i-cume thi kinereiche, y-worthe thi wyll also is in hevene so be on erthe, oure iche-dayes bred ȝif us to day, and forfif us oure gultes, also we forȝifet oure gultare, and ne led ows nowth into fodingge, aith ales ows of harme. So be it.

The next is from a MS., No. 142, in St. John's College Library, Cambridge, of the fourteenth century, and is also from Mr. Maskell's Monumenta Ritualia, ii. 239 :

Fader oure that art in heuene, halwed be thi name : come thi kyngdom : fulfild be thi wil in heuene as in erthe : oure ech day bred ȝef vs to day, and forȝe vs oure dettes as we forȝeuth to oure detoures : and ne led vs nouȝ in temptacion, bote deliuere vs of euil. So be it.

This is from a MS. in the Bodleian Library (Donce, 246, f. 15), of the fifteenth century. It also is reprinted from Monumenta Ritualia, ii. 239 :

Fader oure that art in heuene, halwed be thy name : thy kyngdom come to thee : thy wille be do in erthe as in heuen : oure eche dayes brede ȝeue us to daye : and forȝeue us oure dettes as we forȝeue to oure dettours : and lede us nouȝte into temptacion : bot delyver us from yvel. Amen.

The last is from the Prymer of 1538. Monumenta Ritualia, ii. 239 :

Our father whiche art in heuen, halowed be thy name. Let thy kyngdome cum vnto vs. Thy wyll be fulfilled as well in erthe, as it is in heuen. Gyue vs this daye our daylye breade. And forgyue vs our trespasses, as we forgyue them that trespas agaynst vs. And lede vs nat in to temptacyon. But delyuer vs from euyll. So be it.

Many more such ancient English versions are extant, and the above are only given as specimens which show distinct transitions of language from one age to another. [For others see Reliquiæ Antiquæ, vol. i.; Livgard's Anglo-Saxon Church, vol. ii.;

Maskell's Monumenta Ritualia, vol. ii.; Chamberlayne's Oratio Dominica.]

§ *Exposition of the Lord's Prayer, by St. Cyril of Jerusalem,*
A.D. 347.

[It may give an additional interest to this to mention the historical fact, that it was part of a Lecture delivered in the Church which had been recently erected over the Holy Sepulchre; and to remind the reader that the interval of time between the original delivery of the Divine Prayer to the Apostles and this exposition of it by a Bishop of the Holy City was not greater than that which has elapsed since the setting forth of the Prayer Book in 1549.]

Then, after these things, we say that Prayer which the Saviour delivered to His own disciples, with a pure conscience styling God our Father, and saying, Our Father, which art in heaven. O most surpassing loving-kindness of God! On them who revolted from Him and were in the very extreme of misery, has He bestowed such complete forgiveness of their evil deeds, and so great participation of grace, as that they should even call Him Father. Our Father, which art in heaven; they also are a heaven who bear the image of the heavenly, in whom God is, dwelling and walking in them.

Hallowed be Thy Name. The Name of God is in its own nature holy, whether we say so or not; but since it is sometimes profaned among sinners, according to the words, Through you my Name is continually blasphemed among the Gentiles, we pray that in us God's Name may be hallowed; not that it becomes holy from not being holy, but because it becomes holy in us, when we become holy; and do things worthy of holiness.

Thy Kingdom come. The clean soul can say with boldness, Thy Kingdom come; for he who has heard Paul saying, Let not sin reign in your mortal body, but has cleansed himself in deed, thought, and word, will say to God, Thy Kingdom come.

Thy Will be done as in heaven, so in earth. The divine and blessed Angels do the will of God, as David in a Psalm has said, Bless the Lord, ye His Angels, that excel in strength, that do His Commandments. So then, thou meanest by thy prayer, "As Thy will is done by the Angels, so be it done on earth also by me, Lord."

Give us this day our super-substantial bread. This common bread is not super-substantial bread, but this Holy Bread is super-substantial, that is, appointed for the substance of the soul. For this Bread goeth not into the belly and is cast out into the draught, but is diffused through all thou art, for the benefit of body and soul. But by this day, he means "each day," as also Paul has said, While it is called to-day.

And forgive us our debts as we forgive our debtors. For we have many sins. For we offend both in word and in thought, and very many things do we worthy of condemnation; and if we say that we have no sin, we lie, as John says. And we enter into a covenant with God, entreating Him to pardon our sins, as we also

Answer.

As it was in the beginning, is now,
and ever shall be : world without end.
Amen.

Priest.

Praise ye the Lord.

Answer.

The Lord's Name be praised.

¶ *Then shall be said or sung the Psalms in order as they be appointed. Then a Lesson of the Old Testament, as is appointed: And after that, Magnificat (or the Song of the blessed Virgin Mary) in English, as followeth.*

*Magnificat.
Luke i.*

MY soul doth magnify the Lord :
and my spirit hath rejoiced in
God my Saviour.

As it was in the bygynnyng and
now and euer and in to the worldis of
worldis. So be it.

God make us saaf.]

*In Inter Prymers,
Alleluia.*

Psalmus. Lucae i.

MAGNIFICAT: anima mea Do-
minum. Salisbury Use.

Et exultavit spiritus meus: in Deo
salutari meo.

forgive our neighbours their debts. Considering then what we receive, and for what, let us not put off, nor delay to forgive one another. The offences committed against us are slight and trivial, and easily settled; but those which we have committed against God are great, and call for mercy such as His only is. Take heed, therefore, lest for these small and inconsiderable sins against thyself, thou bar against thyself forgiveness from God for thy most grievous sins.

And lead us not into temptation, O Lord. Does then the Lord teach to pray thus, viz., that we may not be tempted at all? And how is it said elsewhere, "the man who is not tempted is unproved;" and again, My brethren, count it all joy when ye fall into divers temptations; or rather, does not the entering into temptation mean the being whelmed under the temptation? For the temptation is like a winter-torrent, difficult to cross. Some, then, being most skilful swimmers, pass over, not being whelmed beneath temptations, nor swept down by them at all; while others who are not such, entering into them sink in them. As for example, Judas entering into the temptation of covetousness, swam not through it, but sinking beneath it was choked both in body and spirit. Peter entered into the temptation of the denial; but having entered it, he was not overwhelmed by it, but manfully swimming through it, he was delivered from the temptation. Listen again in another place, to the company of unseathed saints, giving thanks for deliverance from temptation, For Thou, O God, hast proved us; Thou hast tried us like as silver is tried. Thou broughtest us into the net; Thou laidest affliction upon our loins. Thou hast caused men to ride over our heads; we went through fire and water; but Thou broughtest us out into a wealthy place; now their coming into a wealthy place, is their being delivered from temptation.

But deliver us from the evil. If Lead us not into temptation had implied the not being tempted at all, He would not have said, But deliver us from the evil. Now the evil is the Wicked Spirit who is our adversary, from whom we pray to be delivered. Then after completing the prayer, Thou sayest, Amen; by this Amen, which means, "So be it," setting thy seal to the petitions of this divinely-taught prayer. [St. Cyril's Catech. Lect. xxiii. 11--18.]

§ *Paraphrase of the Lord's Prayer, by the Author of
"The Christian Year."*

[The following paraphrase is reprinted¹ to illustrate the devotional use of the Lord's Prayer in private, on Liturgical principles. The "special intention" here shown is also one

¹ From the Preface to "Sermons, Academical and Occasional, by the Rev. John Keble, M.A., 1848."

which bears closely upon two objects of this work, that of promoting the present unity of the Church of Christ, and that of showing the unity of the Church of England with the Catholic Church of old.]

Our Father which art in Heaven: One God, the Father Almighty, One Lord Jesus Christ, One Holy Ghost, proceeding from the Father and the Son; have mercy upon us, Thy children, and make us all One in Thee.

Hallowed be Thy name: Thou who art One Lord, and Thy name One; have mercy upon us all, who are called by Thy name, and make us more and more One in Thee.

Thy kingdom come: O, King of Righteousness and Peace, gather us more and more into Thy kingdom, and make us both visibly and invisibly One in Thee.

Thy will be done in earth, as it is in heaven: Thou, Who hast declared unto us the mystery of Thy will, to "gather together in One all things in Christ, both which are in heaven and which are on earth;" conform us, O Lord, to that holy will of Thine, and make us all One in Thee.

Give us this day our daily bread: Thou in Whom we being many are One Bread and One Body; grant that we, being all partakers of that One Bread, may day by day be more and more One in Thee.

And forgive us our trespasses as we forgive them that trespass against us: Thou, Who didst say, *Father, forgive them*, for those who were rending Thy blessed Body, forgive us the many things we have done to mar the unity of Thy mystical Body, and make us, forgiving and loving one another, to be more and more One in Thee.

And lead us not into temptation: As Thou didst enable Thine Apostles to continue with Thee in Thy temptations; so enable us, by Thy grace, to abide with Thee in Thy true Church, under all trials, visible and invisible, nor ever to cease from being One in Thee.

But deliver us from evil: from the enemy and false accuser; from envy and grudging; from an unquiet and discontented spirit; from heresy and schism; from strife and debate; from a scornful temper, and reliance on our own understanding; from offence given or taken; and from whatever might disturb Thy Church, and cause it to be less One in Thee.

GOOD LORD, DELIVER AND PRESERVE THY SERVANTS FOR EVER.

THE MAGNIFICAT.

The Hymn of the Blessed Virgin Mary can be traced in use in the Daily Service of the Church as far back as the beginning of the sixth century. At that time (A.D. 507) it appears in the

Compare the
Song of Han-
nah. 1 Kings
ii. 1-10.

For he hath regarded : the lowliness
of his hand-maiden.

For behold, from henceforth : all
generations shall call me blessed.

For he that is mighty hath magni-
fied me : and holy is his Name.

And his mercy is on them that fear
him : throughout all generations.

He hath shewed strength with his
arm : he hath scattered the proud in
the imagination of their hearts.

He hath put down the mighty from
their seat : and hath exalted the hum-
ble and meek.

He hath filled the hungry with good
things : and the rich he hath sent
empty away.

He remembering his mercy hath
holpen his servant Israel : as he prom-
ised to our forefathers, Abraham and
his seed, for ever.

Glorify be to the Father, and to the
Son : and to the Holy Ghost ;

As it was in the beginning, is now,
and ever shall be : world without end.
Amen.

¶ Or else this Psalm; except it be on the
Nineteenth day of the month, when it is

Quia respexit humilitatem ancillæ Salisburij U⁹,
suæ: ecce enim ex hoc beatam me
dicent omnes generationes.

Quia fecit mihi magna qui potens
est : et sanctum nomen ejus.

Et misericordia ejus a progenie in
progenies : timentibus eum.

Fecit potentiam in brachio suo :
dispersit superbos mente cordis sui.

Deposuit potentes de sede : et ex-
altavit humiles.

Esurientes implevit bonis : et divites
dimisit inanes.

Suscepit Israël puerum suum : re-
cordatus misericordiæ suæ ;

Sicut locutus est ad patres nostros ;
Abraham, et semini ejus in sæcula.

Gloria Patri, et Filio : et Spiritui
Sancto.

Sicut erat in principio, et nunc, et
semper, et in sæcula sæculorum.
Amen.

rule of St. Cæsarius of Arles, in the office of Lauds. In the Eastern Church it is also a Lauds Canticle. But Amalarius [A.D. 820] speaks of its use in his time as a Canticle at Vespers; and in the Armenian Church it is used at Compline as well as at Lauds. The English Church has used it at Vespers for at least eight hundred years; and its present position is analogous to that which it occupied in the ancient Service. There are English versions of it, of as early a date as 1390-1400. Several attempts were made by the Puritans to banish it from the Prayer Book, but happily without success. On the other hand, especial reverence was shown towards this Canticle and the Benedictus in the ceremonial of the ancient Church of England, by the use of incense while they were being sung. [See the ceremony in full in Transl. of Sar. Psalt. p. 327.]

Of all Hymns known to the Church this is the most closely connected with our Blessed Lord, having been spoken by His Virgin Mother, under the inspiration of the Holy Ghost, at the very season when the Divine overshadowing brought about the Incarnation of the Word. She began to be, in that moment, the "tabernacle for the Sun" of Righteousness, "Which cometh forth as a Bridegroom out of His chamber, and rejoiceth as a giant to run His course." The appearance and words of the Archangel revealed to her the exalted office to which God had chosen her, and she knew that from that hour she was to carry in her bosom for nine months the Saviour of the world. But though so "highly favoured," and "full of grace," and conscious of being, as Jeremy Taylor says, "superexalted by an honour greater than the world ever saw," all her words are uttered in a spirit of profound humility as regards herself, even when she declares that "all generations shall call me Blessed," and of the most heavenly adoration as regards Him Who had magnified her.

The Mother of our Lord, and the Church, "which is the Mother of us all," have always been closely linked together in the

mind of Christianity. The "Elect Lady," and the Woman "clothed with the sun, and the moon under her feet, and upon her head a crown of twelve stars," who, "being with child, cried, travailing in birth, and pained to be delivered," and who "brought forth a man child, who was to rule all nations with a rod of iron: and her child was caught up unto God, and to His throne," have seemed, from the different points of view taken by different ages, to represent now one and then the other, the Mother of our Lord, and the Mother of us all. This community of characteristics is in accordance with the general teaching of the New Testament respecting the mystery of the communion between our Lord Himself and those who are made members of His Body by new birth. And for this reason, "The Song of the Blessed Virgin Mary" has a peculiar fitness as the daily song of the Church of Christ, since God has honoured it with so great honour, in having made it the means by which the work of the Incarnation is made effectual to the salvation of souls. The Blessed Virgin Mother offered up her thanksgiving to God because He had remembered His mercy and His ancient covenant, by making His Son incarnate through her; and the Church offers up her thanksgiving to Him, because, through her, the mystical body of Christ is being continually brought forth to His greater glory.

It is also to be observed of this, as of the other Canticles, that it is sung to the praise of the Personal Word, as revealed in the Written Word; to the praise of God in Christ, revealed in the Old Testament Scriptures as well as in the New.

CANTATE DOMINO.

This Psalm was not used in any other way than in its place in the Psalter (Mattins, on Saturdays) until 1552, when it was inserted here as an alternative responsory to the first lesson, probably for the purpose of meeting the objections to the *Magnificat*

read in the ordinary course of the
Psalms.

*Cantate Do-
mino. Ps.
xcviii.*

O SING unto the Lord a new song : for he hath done marvellous things.

With his own right hand, and with his holy arm : hath he gotten himself the victory.

The Lord declared his salvation : his righteousness hath he openly shewed in the sight of the heathen.

He hath remembered his mercy and truth toward the house of Israel : and all the ends of the world have seen the salvation of our God.

Shew yourselves joyful unto the Lord, all ye lands : sing, rejoice and give thanks.

Praise the Lord upon the harp : sing to the harp with a psalm of thanksgiving.

With trumpets also and shawms : O shew yourselves joyful before the Lord the King.

Let the sea make a noise, and all that therein is : the round world, and they that dwell therein.

Let the floods clap their hands, and let the hills be joyful together before the Lord : for he cometh to judge the earth.

With righteousness shall he judge the world : and the people with equity.

Glory be to the Father, and to the Son : and to the Holy Ghost ;

As it was in the beginning, is now, and ever shall be : world without end. Amen.

Psalmus xcvi.

CANTATE Domino canticum novum : quia mirabilia fecit. Salisbury Use.

Salvavit sibi dextera ejus : et brachium sanctum ejus.

Notum fecit Dominus salutare suum : in conspectu gentium revelavit justitiam suam.

Recordatus est misericordiae suae : et veritatis suae Domui Israel.

Viderunt omnes termini terrae salutare Dei nostri : jubilate Deo omnis terra : cantate et exultate et psallite.

Psallite Domino in cithara, in cithara et voce psalmi : in tubis ductilibus, et voce tubae corneae.

Jubilate in conspectu Regis Domini : moveatur mare et plenitudo ejus : orbis terrarum et qui habitant in eo.

Flumina plaudent manu, simul montes exultabunt a conspectu Domini : quoniam venit judicare terram.

Judicabit orbem terrarum in justitia : et populos in aequitate.

which had been raised by the Puritans. It bears some resemblance, in its latter verses, to the *Benedicite Omnia Opera*, the works of God by land and sea being called upon to join in His praise.

It has also been suggested that there are parallel expressions in the *Cantate* and the *Magnificat*, which seem to indicate that the latter is in some degree founded on the former. These are the following :—

Magnificat.

He that is mighty hath magnified me [or "done to me great things"].

He hath shewed strength with His arm : He hath scattered the proud . . . He hath put down the mighty.

His mercy is on them that fear Him : throughout all generations.

Cantate Domino.

He hath done marvellous things.

With His own right hand and with His holy arm : hath He gotten Himself the victory.

The Lord declared His salvation : His righteousness hath He openly shewed in the sight of the heathen.

He remembering His mercy hath holpen His servant Israel. He hath remembered His mercy and truth toward the house of Israel.

Whether this parallel is accidental or not, it may serve to show the Evangelical character of the Psalm which is permitted to be used as a substitute for the Song of the Blessed Virgin Mary. Yet it does not seem as if there was ever any necessity for superseding the latter; and, where choice is given, the *Magnificat* may well be preferred as being offered up daily to God's praise by the whole Catholic Church. When Evensong is repeated, it may be considered advisable to use the alternative Canticle at one of the Services; but, in that case, the *Magnificat* should always be said at the later Evensong.

NUNC DIMITTIS

The "Song of Simeon" is another Canticle in praise of the manifestation of the Incarnate Word. It has been used at Compline or at Vespers throughout the Church from the earliest ages, being mentioned in the Apostolical Constitutions (written in the

¶ Then a Lesson of the New Testament, as it is appointed: And after that, *Nunc dimittis* (or the Song of Simeon) in English, as followeth.

Nunc Dimittis,
Luke ii. 29.

LORD, now lettest thou thy servant depart in peace : according to thy word.

For mine eyes have seen : thy salvation.

Which thou hast prepared : before the face of all people ;

To be a light to lighten the Gentiles : and to be the glory of thy people Israel.

Glorify be to the Father, and to the Son : and to the Holy Ghost ;

As it was in the beginning, is now, and ever shall be : world without end. Amen.

¶ Or else this Psalm ; except it be on the Twelfth day of the month.

Deus Misereatur,
Ps. lxxvii.

GOD be merciful unto us, and bless us : and shew us the light of his countenance, and be merciful unto us.

That thy way may be known upon earth : thy saving health among all nations.

Let the people praise thee, O God : yea, let all the people praise thee.

O let the nations rejoice and be glad : for thou shalt judge the folk righteously, and govern the nations upon earth.

Canticum Simeonis. Lucae ii.

NUNC dimittis servum tuum, Domine : secundum verbum tuum in pace.

Quia viderunt oculi mei : salutare tuum.

Quod parasti : ante faciem omnium populorum ;

Lumen ad revelationem gentium : et gloriam plebis tuæ Israël.

Gloria Patri, et Filio, et Spiritui Sancto.

Sicut erat in principio, et nunc, et semper, et in sæcula sæculorum. Amen.

Psalmus lxxvi.

DEUS misereatur nostri, et benedicat nobis : illuminet vultum suum super nos, et misereatur nostri.

Ut cognoscamus in terra viam tuam : in omnibus gentibus salutare tuum.

Confiteantur tibi populi Deus : confiteantur tibi populi omnes.

Lætentur et exultent gentes, quoniam judicas populos in æquitate, et gentes in terra dirigis.

early part of the fifth century, at the latest) as an Evening Canticle. There are English versions of it as early as the fourteenth century.

The *Nunc Dimittis* is so singularly fitted for Evensong, as to seem as if written for the purpose. Like the words of David, "I will lay me down in peace and take my rest, for it is Thou, Lord, only that makest me to dwell in safety;" it is the aspiration of that faith which can behold Christ lightening the darkness of all night, and fulfilling the words of the prophet, "It shall come to pass, that at evening time it shall be light." As the Gospels of the Morning Lessons reveal to us the "Day-spring" from on high "visiting us," so the Epistles of the Evening Lessons reveal the Light of Christ's glory enlightening the Gentile as well as the Jewish world.

In the old Evening Services of the Church of England, there were touching references to death, and the rest of the departed ; and immediately after *Nunc Dimittis*, in Passion and Holy Week, was sung the glorious anthem "*Media vita in morte sumus*," which is now used only in the Burial Service. This close connexion between the Song of Simeon and the idea of our Blessed Lord's Passion arises out of the occasion on which it was first uttered, the Presentation, which was in effect a Sacrifice ; and of the words of Simeon which immediately followed, "Behold, this child is set for the fall and rising again of many in Israel ; and for a sign which shall be spoken against ; yea, a sword shall pierce through thine own soul also, that the thoughts

of many hearts may be revealed." [Luke ii. 34, 35.] And such a connexion of ideas cannot fail to remind us also of our Lord's own departing words, "Father, into Thy hands I commend My Spirit," when "He saw of the travail of His soul," as the eyes of Simeon saw the salvation of the Lord, "and was satisfied." This calm repose of faith on God,—looking for a present rest on the bosom of Jesus, and a future rest in His Paradisal Presence,—has always been the tone of Evensong in the Church ; and is one that will always be in harmony with the feelings of those whose day has been a day of work ; who look solemnly, yet not gloomily, towards that coming night when no man can work ; and whose eyes are fixed with hope on that "rest which remaineth for the people of God," through the salvation which Christ has prepared.

DEUS MISEREATUR.

This Psalm was inserted, like the *Cantate Domino*, in 1552, but was familiar in the older services, being the fourth fixed Psalm at Lauds on Sundays. It was also part of the Office of Bidding Prayers which was used every Sunday. Although of a more jubilant character than the *Nunc Dimittis*, it has several features in common with it, besides this connexion with an office in which the departed were commemorated. Like that, it praises God for the extension of the Gospel : and as Simeon offers thanksgiving that his eyes have seen the salvation of God, so David in this

Let the people praise thee, O God :
yea, let all the people praise thee.

Then shall the earth bring forth her
increase : and God, even our own God,
shall give us his blessing.

God shall bless us : and all the ends
of the world shall fear him.

Glory be to the Father, and to the
Son : and to the Holy Ghost ;

As it was in the beginning, is now,
and ever shall be : world without end.
Amen.

¶ *Then shall be said or sung the Apostles'
Creed by the Minister and the people,
standing.*

[See other refer-
ences in Morn-
ing Prayer.]
Heb. x. 23.
2 Chron. xx. 20.
Deut. vi. 4, 5.
Mal. iv. 10.
Exod. vi. 8.
John i. 18, 41, 42.
vi. 69.

I BELIEVE in God the Father
Almighty, Maker of heaven and
earth :

And in Jesus Christ his only Son
our Lord, Who was conceived by the

Confiteantur tibi populi Deus, con- Salisbury Use.
fiteantur tibi populi omnes, terra dedit
fructum suum.

Benedicat nos Deus, Deus noster ;
benedicat nos Deus : et metuant eum
omnes fines terræ.

Gloria Patri, et Filio, et Spiritui
Sancto.

Sicut erat in principio, et nunc, et
semper, et in sæcula sæculorum.
Amen.

[Credo in.

Prymer Version
of XIVth cen-
tury.

I BILEUE in god, fadir almyȝti,
I makere of heuene and of *erthe :
and in iesu crist the sone of him, oure
lord, oon aloone : which is conceyued
of the hooli gost : born of marie

Psalm prays that the Light of His countenance may be shown to
us, and His saving health known among *all* nations.

Occasions may arise when this Canticle is peculiarly appropriate :
but for ordinary Evensong (and especially for the later of two ser-
vices) it is better always to keep to the ancient spirit and practice
of the Church, and use the *Nunc Dimittis*.

THE APOSTLES' CREED.

A large number of early English versions of the Creed are ex-
tant. The one in the right-hand column above is taken from the
ancient Prymer contained in Maskell's Monumenta Ritualia. The
others which follow this note are copied from Professor Heurtley's
"Harmonia Symbolica," where several others, of various dates,
from the ninth to the sixteenth century, are to be found¹.

IXth Century. From a MS. (No. 427) in the Lambeth Library.

Ic gelyfe on God Fæder ælmihtigne, Scyppend heofonan and
eorthan ; And on Hælend Crist, Sunu his anlican, Drihten urne ;
Se the wæs geacnod of tham Halgan Gaste, Acænned of Marian
tham mædene ; Gethrowad under tham Pontiscan Pilate, Gerod
fæstnad, Dead and bebyrged ; He nither astah to hel warum ;
Tham thriddan dæge he aras fram deadum ; He astah to heofon-
num ; He sit to swyðþran hand God Fæder wæs ælmihtigan ;
Thonan toward deman tha cucan and tha deadan. Ic gelyfe
Tha halgan gelathunge riht gelyfdan ; Halgana gemænysses ;
And forgyfnysse synna ; Flascas æriste ; And thæt ece lif. Si
hit swa.

[The next is of great interest from the illustration it affords of
the necessity thrust on the Church of England during a part of
the middle ages, of teaching her people in three different lan-
guages. It also represents the three principal elements of modern
English.]

*Circ. A.D. 1125. From a MS. (R. 17) in the Library of Trinity
College, Cambridge.*

Ic gelefe on Gode Fædera ælwealdend,
Jeo crei en Deu le Perre tut puant,
Credo in Deum Patrem omnipotentem,
Sceppend heofones and eorthan ;
Le criatur de ciel e de terre ;
Creatorem cœli et terræ ;

¹ The student should compare Professor Heurtley's book with Walchius'
Bibliotheca Symbolica for the earliest forms of the Creed.

And on Helende Crist, Suna his anlich,
E ep Jesu Crist, sun Fil uniel,
Et in Jesum Christum Filium ejus unicum.

Drihten ure ;
Nostre Seinur ;
Dominum nostrum ;

Syo the akynned is of tham Halig Gaste,
Ki concevz est del Seint Esprit,
Qui conceptus est de Spiritu Sancto,

Boran of M[arian tham mæden ;]
Nez de Marie la
Natus ex Maria Virgine :

[Gethrowode under tham Pontiscam] Pilate,
and on rode ahangen,
* * * * * ntiem Pilate crucifiz,
Passus sub Pontio Pilato, crucifixus.

Dead and beberiged ;
Morz, e seveliz ;
Mortuus, et sepultus ;

He adun astæh to hellæ ;
Descedied as enfers ;
Descendit ad inferna ;

Thriddan degge he aras fram deatha ;
Et tierz jurn relevad de morz ;
Tertia die resurrexit a mortuis ;

He astah to heofone ;
Muntad as ciels ;
Ascendit ad celos ;

Sit on switran healfe Godes Fæderes ealmihtig ;
Siet a la destre de Deu Perre tres tut puant ;
Sedet ad dexteram Dei Patris omnipotentis ;

Thanen he is to cumene, and to demenna quiche and deade
Dilue est avenir jugier les vis e les morz.
Inde venturus judicare vivos et mortuos.

Ic gelefe on Halig Gast ;
Jeo crei el Seint Esprit ;
Credo in Spiritum Sanctum ;

Isa. vii. 14.
 Luke i. 30, 31.
 Mark xv. 15—29.
 24, 46.
 Eph. iv. 9, 10.
 Luke xxiv. 50—
 53.
 Acts vii. 55, 56.
 Rom. xiv. 9, 10.
 2 Tim. iv. 1.
 1 John v. 7.
 John xv. 26.
 Matt. iii. 11, 16.
 Eph. v. 27—32.
 1 John i. 3, 7.
 John xi. 23—25.
 1 Cor. xv. 12—19.
 Mark ix. 43—49.
 1 Pet. i. 4.
 Rev. i. 7.

Holy Ghost, Born of the Virgin Mary,
 Suffered under Pontius Pilate, Was
 crucified, dead, and buried; He de-
 scended into hell; The third day he
 rose again from the dead, He ascended
 into Heaven, And sitteth on the right
 hand of God the Father Almighty;
 From thence he shall come to judge
 the quick and the dead.

I believe in the Holy Ghost; The
 holy Catholick Church; The Commu-
 nion of Saints; The Forgiveness of
 sins; The Resurrection of the body,
 And the life everlasting. Amen.

¶ *And after that, these Prayers following, all
 devoutly kneeling; the Minister first pro-
 nouncing with a loud voice,*

The Lord be with you.

Answer.

And with thy spirit.

Minister.

¶ Let us pray.

Lord, have mercy upon us.

Christ, have mercy upon us.

Lord, have mercy upon us.

¶ *Then the Minister, Clerks, and people, shall
 say the Lord's Prayer with a loud voice.*

Luke xi. 2.

OUR Father, which art in heaven,
 Hallowed be thy Name. Thy
 kingdom come. Thy will be done in
 earth, As it is in heaven. Give us
 this day our daily bread. And forgive
 us our trespasses, As we forgive them
 that trespass against us. And lead us
 not into temptation; But deliver us
 from evil. Amen.

maiden: suffride passioun undir pounce
 pilat: crucified, deed, and biried: he
 wente down to hellis: the thridde day
 he roos aȝen fro deede; he steiȝ to
 heuenes: he sittith on the riȝt syde
 of god the fadir almyȝti: thenus he
 is to come for to deme the quyke and
 deede. I beleue in the hooli goost:
 feith of hooli chirche: communynge
 of seyntis: forȝuennesse of synnes:
 aȝenrisyng of fleish, and euerlastynge
 lyf. So be it.]

[Preie we.

Lord, have merci on us.

Crist, have merci on us.

Lord, have merci on us.]

*Prymer Version
 of XIVth cen-
 tury.*

[ΠΑΤΕΡ ἡμῶν ὁ ἐν τοῖς οὐρανοῖς, Δουκ. xi. 2.
 ἀγιασθήτω τὸ ὄνομά σου ἐλθέτω ἡ
 βασιλεία σου γενηθήτω τὸ θέλημα
 σου, ὡς ἐν οὐρανῷ, καὶ ἐπὶ τῆς γῆς.
 Τὸν ἄρτον ἡμῶν τὸν ἐπιούσιον δίδου
 ἡμῖν τὸ καθ' ἡμέραν καὶ ἄφεσις ἡμῖν
 τὰς ἀμαρτίας ἡμῶν, καὶ γὰρ αὐτοὶ
 ἀφίεμεν παντὶ ὀφείλοντι ἡμῖν καὶ μὴ
 ῥύσαι ἡμᾶς ἀπὸ τοῦ πονηροῦ.]

And on halig gesomnunge fulfremede;
 Sainte Eglise Catholica;
 Sanctam Ecclesiam Catholicam;
 Halegan hiniennesse;
 La communion des saintes choses;
 Sanctorum communionem;
 Forgyfensyse synna;
 Remissum des pecchiez;
 Remissionem peccatorum;
 Fleases up arisnesse;
 Resurrectionem de charrn;
 Carnis resurrectionem;

Lif eche
 Vie pardurable
 Vitam eternam
 Beo hit swa.
 Seit feit.

*XIIIth Century. From a MS. in the British Museum, Cleo-
 patra, B. vi., fol. 201.*

Hi true in God, Fader Hal-nichttende, That makede heven
 and herdeth; And in Jhesu Krist, is ane lepi Sone, Hure Laverd;
 That was bigotin of the Hali Gast, And born of the mainden
 Marie; Pinid under Pance Pilate, festened to the rode, Ded, and
 dulvun; Licht in til helle; The thride dai up ras fra dede to
 live; Steg intil hevenne; Sitis on his Fadir richt hand, Fadir al-
 waldand; He then sal come to deme the quike an the dede. Hy
 troue hy theli Gast; And hely * * kirke; The samninge of
 halges; Forgyfnes of sinnes; Uprisigen of fleyes; And life
 withuten ende. Amen.

*From the Prymer of 1538. Maskell's Monumenta Ritualia,
 ii. 241.*

I beleue in god the father almyghty, maker of heuen and
 earthe; And in Jesu Chryst hys onely sonne, our Lorde; whiche
 was conceyued by the holy ghoste, And borne of the virgyn
 Mary; which suffred deathe under Pons Pylate, and was crucified,
 deade, and buryed; which descendyd to hell; The thyrde day

¶ *Then the Priest standing up shall say,*

O Lord, shew thy mercy upon us.

Answer.

And grant us thy salvation.

Priest.

O Lord, save the Queen.

Answer.

And mercifully hear us when we call upon thee.

Priest.

Endue thy Ministers with righteousness.

Answer.

And make thy chosen people joyful.

Priest.

O Lord, save thy people.

Answer.

And bless thine inheritance.

Priest.

Give peace in our time, O Lord.

Answer.

Because there is none other that fighteth for us, but only thou, O God.

Priest.

O God, make clean our hearts within us.

Answer.

And take not thy holy Spirit from us.

¶ *Then shall follow three Collects; the first of the Day; the second for Peace; the third for Aid against all Perils, as hereafter followeth: which two last Collects shall be daily said at Evening Prayer without alteration.*

¶ *The Second Collect at Evening Prayer.*

Prov. xvi. 1. viii.
14.
Phil. ii. 13.
Isa. xxvi. 12.
John xiv. 27.
Deut. v. 29.
Rev. xxii. 14.
Luke i. 70, 71, 74,
75.

O GOD, from whom all holy desires, all good counsels, and all just works do proceed; Give unto thy servants that peace which the world cannot give; that both our hearts may

[Lord, shew to us thi merci.

*Prymer Version
of XIVth cen-
tury.*

And þeue to us thi saluacion.]

[Lord, þyue pees in oure daies, for ther is noon othir that shal fyte for us, but thou lord oure god.] *Prymer Version
of XIVth cen-
tury.*

DEUS, a quo sancta desideria, recta consilia, et justa sunt opera: da servis tuis illam quam mundus dare non potest pacem: ut et corda nostra mandatis tuis dedita, et,

rose from death to lyfe; whiche ascendyd into heuen; and sytheth at the ryght hande of God the Father almyghtye; And from thens shall come for to judge both the quycke and the deade. I beleue in the holy Ghoste; The holy churche catholike; The communion of sayntes; The remysyon of synnes; The resurrectyon of the flesshe; And the lyfe euerlastyng. So be it.

THE SECOND COLLECT.

[*Prymer Version of XIVth Century.*

Preie we. For the pees. Deus a quo.

God, of whom ben hooli desiris, riht counsels and iust werkis: þyue to thi seruantis pees that the world may not þeue, that in

our hertis þoun to thi commandementis, and the drede of enemyes putt awei, owre tymes be pesible thur; thi defendyng. Bi oure lord iesu crist, thi sone, that with thee lyueth and regneth in the unities of the hooli goost god, bi all worldis of worldis. So be it.]

This prayer is the Collect of the same *Missa pro pace*, of which the Morning Collect for Peace is the "Post-Communion." It also was used at Lauds, at Vespers, and in the Litany in the ancient Services: and dates from the Sacramentary of Gelasius, A.D. 494.

Coming as it originally did, at the close of Evensong, it formed a sweet cadence of prayer, fitly concluding with the following short but touching collect. It follows up very exactly the tone of the Nunc Dimittis, and rings with a gentle echo of the peace

Isa. xxxii. 17, 18.
2 Thess. iii. 16.

be set to obey thy commandments, and also that by thee we being defended from the fear of our enemies may pass our time in rest and quietness; through the merits of Jesus Christ our Saviour.
Amen.

¶ *The Third Collect, for aid against all Perils.*

2 Sam. xxii. 29.
Ps. xci. 5, 6.
cxli. 4, 5.
John xv. 9. 13.
xvi. 23, 27.
Eph. v. 19.

LIGHTEN our darkness, we beseech thee, O Lord; and by thy great mercy defend us from all perils and dangers of this night; for the love of thy only Son, our Saviour, Jesus Christ. *Amen.*

¶ *In Quires and Places where they sing, here followeth the Anthem.*

¶ *A Prayer for the Queen's Majesty.*

OLORD our heavenly Father, high and mighty, King of kings, Lord of lords, the only Ruler of princes, who dost from thy throne behold all the dwellers upon earth; most heartily we beseech thee with thy favour to behold our most gracious Sovereign Lady, Queen *VICTORIA*; and so replenish her with the grace of thy holy Spirit, that she may alway incline to thy will, and walk in thy way: Endue her plenteously with heavenly gifts; grant her in health and wealth long to live; strengthen her that she may vanquish and overcome all her enemies; and finally, after this life, she may attain everlasting joy and felicity; through Jesus Christ our Lord. *Amen.*

¶ *A Prayer for the Royal Family.*

ALMIGHTY God, the fountain of all goodness, we humbly beseech thee to bless *Albert Edward* Prince of *Wales*, the Princess of *Wales*, and all

hostium sublata formidine, tempora
sint tua protectione tranquilla. Salisbury Use.

ILLUMINA, quæsumus, Domine Deus, tenebras nostras: et totius hujus noctis insidias tu a nobis repelle propitius. Per Dominum nostrum Jesum Christum Filium tuum, qui tecum vivit et regnat in unitate Spiritus Sancti Deus, per omnia sæcula sæculorum. *Amen.* Salisbury Use. Greg. and Gelas. Orat. ad Completorium.

¶ *A Prayer for the Kyng.* • Prymer of 1553.

MOST merciful father, al we thy seruantes by dutie, and children by grace, do beseeche thee mooste humbly, to preserue Edwarde the Syxt thy sonne and seruante, and oure Kyng and gouernour: Sowe in hym good Lorde suche seede of vertue now in hys yonge age, that many yeares this Realme maye enioye much fruite of this thy blessynge in hym, throughe Jesus Christe our Lorde. *Amen.*]

that lies beyond this world, as well as of the peace which the world cannot give, nor the soul entirely receive while it is in the world. In the morning collect the tone of the prayer was that of one who asks God of His mercy to bless and co-operate with his own in their strife against spiritual foes: but in the evening the words are more those of one who is no longer able to strive against his enemies, but looks to his Lord God alone to be his defence and his shield.

[Between the second and third Collect at Evening Prayer, Bishop Cosin wished to insert the second of the Collects appended to the Communion Service, "O Almighty Lord, and everlasting God," under the title of "The Collect for grace and protection," but the alteration was rejected. The idea seems to have been taken from the York Litany.]

THE THIRD COLLECT.

This prayer is of equal antiquity with the preceding: and is expressly appointed to be used at Evening Prayer in the Sacramentary of Gelasius. It was taken into our Evensong from the Compline of the Salisbury Use. Here again the *Nunc Dimittis* is followed up in its tone: but the words are taken almost literally from the Psalms, which have been the great storehouse of Prayer as well as Praise to the Church of all ages. "Consider and hear me, O Lord my God: lighten mine eyes that I sleep not in death. Thou also shalt light my candle: the Lord my God shall make my darkness to be light. Yea, the darkness is no darkness with Thee, but the night is as clear as the day: the darkness and light to Thee are both alike. He will not suffer thy foot to be

the Royal Family: Endue them with thy holy Spirit; enrich them with thy heavenly grace; prosper them with all happiness; and bring them to thine everlasting kingdom; through Jesus Christ our Lord. *Amen.*

¶ *A Prayer for the Clergy and People.*

ALMIGHTY and everlasting God, who alone workest great marvels; Send down upon our Bishops, and Curates, and all Congregations committed to their charge, the healthful Spirit of thy grace; and that they may truly please thee, pour upon them the continual dew of thy blessing. Grant this, O Lord, for the honour of our Advocate and Mediator, Jesus Christ. *Amen.*

¶ *A Prayer of St. Chrysostom.*

ALMIGHTY God, who hast given us grace at this time with one accord to make our common supplications unto thee; and dost promise, that when two or three are gathered together in thy Name, thou wilt grant their requests; Fulfil now, O Lord, the desires and petitions of thy servants, as may be most expedient for them; granting us in this world knowledge of thy truth, and in the world to come life everlasting. *Amen.*

2 Cor. xiii.

THE grace of our Lord Jesus Christ, and the love of God, and the fellowship of the Holy Ghost, be with us all evermore. *Amen.*

Here endeth the Order of Evening Prayer throughout the Year.

ALMYGHTEI god, euerlastynge, that aloone doost many wondres, schewe the spirit of heelful grace upon bisschopes thi seruantis, and vpon alle the congregacion betake to hem: and ꝑeete in the dewe of thi blessynge that thei plese euermore to the in trouthe. Bi crist oure lord. So be it.

Primer Version of XIVth century.

moved: and He that keepeth thee will not sleep. Behold, He that keepeth Israel: shall neither slumber nor sleep. The Lord Himself is thy keeper: the Lord is thy defence upon thy right hand. So that the sun shall not burn thee by day: neither the moon by night. He shall deliver thee from the snare of the hunter: and from the noisome pestilence. He shall defend thee under His wings, and thou shalt be safe under His feathers: His faithfulness and truth shall be thy shield and buckler. Thou shalt not be afraid for any terror by night: nor for the arrow that flieth by day: for the pestilence that walketh in darkness: nor for the sickness that destroyeth in the noon-day. For Thou art my strong rock, and my castle: be Thou also my guide, and lead me for Thy Name's sake. Into Thy hands I commend my spirit: for Thou hast redeemed me, O Lord, Thou God of truth. I will lay me down in peace, and take my rest: for it is Thou, Lord, only that makest me dwell in safety."

Such are words from the Psalms of David which may be taken as a Scriptural comment upon this short but condensed Collect. They show us how literally the latter must be taken if we are to enter into its true spirit: how much solemn reference to the

present and the future may be drawn into the compass of a few words of prayer: and what a fulness of devotion is contained in even the shortest of those forms which have come down to us as the day by day utterances of the Church of God for so many ages.

To meet objections which were made to the words of this prayer, Bishop Cosin has altered it in his Durham Book, to "Lighten the darkness of our hearts, we beseech Thee, O Lord, by Thy gracious visitation, and of Thy great mercy from all terrors and dangers of the night" Happily the ancient words were retained.

The peculiar fitness of these words to end a Service which is really offered in the Evening, is so great, that one cannot wonder at the reluctance shown by the Clergy and People to add on the Intercessory Prayers which now follow. And, although the Rubric directing these prayers to be used after the Anthem is not inserted in the Evening Service, its omission by no means weakens the force of what has been said in the Notes on Morning Prayer as to such a termination of the Daily Service.

AT MORNING PRAYER.

¶ Upon these Feasts; Christmas-day, the Epiphany, Saint Matthias, Easter-day, Ascension-day, Whitsun-day, Saint John Baptist, Saint James, Saint Bartholomew, Saint Matthew, Saint Simon and Saint Jude, Saint Andrew, and upon Trinity-Sunday, shall be sung or said at Morning Prayer, instead of the Apostles' Creed, this Confession of our Christian Faith, commonly called The Creed of Saint Athanasius, by the Minister and people standing.

Quicumque
vult.
[See also Apos-
tles' and
Nicene Creeds.]
Mark xvi. 15, 16.
Jude 3. 20.

WHOSOEVER will be saved ;
before all things it is necessary
that he hold the Catholick Faith.

Symbolum Athanasii.

QUICUNQUE vult salvus esse: Salisbury Use.
ante omnia opus est ut teneat
catholicam fidem.

THE ATHANASIAN CREED.

It was the ancient usage of the Church of England (from the 7th century to the 16th) to sing the "*Symbolum Athanasii*" every day, rather as a kind of Christian Psalm than a Creed, immediately after the Psalms of the Office, that of Prime. In the reformed Breviary of Quignonez it was confined to Sunday use. In the first edition of the English Prayer Book (1549) the Athanasian Creed was directed to be said on six Festivals, those of Christmas, Epiphany, Easter, Ascension, Pentecost, and Trinity: and seven Saints' days were added in 1552, so as to make thirteen days altogether; its recitation thus becoming a monthly instead of a weekly one, as in the Roman, or a daily one as in the ancient English Church.

In the Durham Prayer Book, Bishop Cosin has substituted for the latter words of the Rubric, "one verse by the priest, and another by the people, or in Colleges, and where there is a Quire, by sides."

The English of our present version is substantially identical with that of Bishop Hilsey, as printed in the Prymer of 1539: and entitled "The Symbole of the great Doctour Athanasius, dayly red in the Church." The Creed does not appear in the earlier English Prymers; but vernacular translations of it are extant of as ancient a date as the ninth century, and many in later English.

Although this "Confession of our Christian Faith" is "commonly called the Creed of St. Athanasius," it cannot be traced back to that great champion of "the right Faith," and is not likely to have been written in Greek: no Greek copy of it being known which is much more than four centuries old: nor any spoken of by any writer earlier than A.D. 1200. It is found in Latin as early as A.D. 570, when a commentary was written upon it by Venantius Fortunatus, previously to his consecration as Bishop of Poitiers¹. From such a commentary being written, it may be concluded that the subject of it was already in public use in Divine Service, as a Confession of Faith, in the Church of France; but it was not adopted by the Church of Rome until A.D. 980.

This Confession of Faith is attributed by Waterland to St. Hilary of Arles, who died A.D. 449, but by Harvey [History and Theology of the Three Creeds, p. 580] to Victricius, Bishop of Rouen, fifty years earlier, i. e. at the close of the fourth and the beginning of the fifth centuries. Some imputations had been cast on the orthodoxy of this Apostolic Bishop and Confessor:

and there are strong reasons for supposing that he composed it as an answer to these charges of false doctrine, and thus expounded his belief before Anastasius, who was Bishop of Rome until April, A.D. 402. From this circumstance Mr. Harvey considers the present name of the Creed to have arisen through the errors of scribes. In a Gallican MS. of the ninth century, it is attributed to "Anasthasius," the name of Victricius being expunged from the title; and a Commentator entitles it "*Fides Anastasii Papæ*." Mr. Harvey thinks that the title "*Fides S. Athanasii*," has been substituted by a writer who knew nothing of Anastasius, and thought that he was correcting an error rightly instead of wrongly: and whose own error was so plausible that it has been followed very generally in subsequent ages. The name of Athanasius is not connected with it in the earliest MSS., nor in the Commentary of Venantius Fortunatus, but it is simply entitled "*Fides Catholica*:" yet, as early as the Council of Autun, A.D. 670, it is called "*Fides Sancti Athanasii Præsulis*," and almost always afterwards either by that title or some other,—as "*Sermo Athanasii de Fide*,"—in which that saint's name is included.

The opinion of Mr. Harvey that it was written by Victricius, A.D. 401, is supported by him with evidence of which the following is his own summary, quoted from page 583 of the History and Theology of the Three Creeds:—"For four several reasons, therefore, it is quite as probable that the authorship of the Creed may be assigned to Victricius, as to Hilary. 1. Its careful, well-considered terms, are more consistent with the mature age of the former, who had attained the honour of Confessor forty years before the date now assigned to the Creed in 401, than with the youth of the latter, who was only eight and twenty years of age, when he is supposed by Waterland to have composed this Creed, on his advancement to the episcopate. 2. Its style, though not that of an apology in vindication of the writer's faith, agrees well with the supposition, that he was accused of the errors that he anathematizes. 3. Its matter is exactly parallel with the subjects, upon which Victricius, if we may judge from the expressions of Paulinus, was called to defend himself. With respect to both of these last particulars, the supposition that Hilary should have been the author, is singularly unsatisfactory to the judgment. His exposition of faith, on entering upon his episcopal office, would scarcely have been pointed with anathemas, that the history of his time persuades us were not required. Indeed the Creed can only be assigned to Hilary upon the supposition, that Apollinarianism infested the Gallican Church at the date of his appointment to the See of Arles; a supposition wholly contrary to fact. But since we know, that Pelagian tenets had then taken a firm root in the south of France, we know also the direction that any

¹ This commentary may be found at the end of Waterland's History of the Athanasian Creed: p. 194 of the Christian Knowledge Society's edition.

Deut. iv. 2.
Rev. xxii. 18, 19.
Acts xiii. 46.
2 John 9.

Which Faith, except every one do keep whole and undefiled : without doubt he shall perish everlastingly.

Mark xii. 32.
Matt. xxviii. 19.

And the Catholick Faith is this : That we worship one God in Trinity, and Trinity in Unity ;

1 Pet. i. 2.
2 Cor. xiii. 14.
1 John v. 7.

Neither confounding the Persons : nor dividing the Substance.

Matt. iii. 16, 17.

For there is one Person of the Father, another of the Son : and another of the Holy Ghost.

John i. 1, 14.
x. 30. xvi. 13—15.
Cf. Isa. vi. 1, 2, 3,
with John xii.
40, 41, and Acts
xxviii. 25, 26.

But the Godhead of the Father, of the Son, and of the Holy Ghost, is all one : the Glory equal, the Majesty co-eternal.

Acts xvii. 24, 28.
John i. 1st 3.
Job xxxiii. 4.

Such as the Father is, such is the Son : and such is the Holy Ghost.

The Father uncreate, the Son uncreate : and the Holy Ghost uncreate.

Job xi. 7—9.
1 Kings viii. 27.

The Father incomprehensible, the

Quam nisi quisque integram, inviolatamque servaverit : absque dubio in æternum peribit. Salisbury Use.

Fides autem catholica hæc est, ut unum Deum in Trinitate : et Trinitatem in Unitate veneremur.

Neque confundentes personas, neque substantiam separantes.

Alia est enim persona Patris, alia Filii : alia Spiritus Sancti.

Sed Patris, et Filii, et Spiritus Sancti, una est Divinitas : æqualis gloria, coæterna majestas.

Qualis Pater, talis Filius : talis Spiritus Sanctus.

Increatus Pater, increatus Filius, increatus Spiritus Sanctus.

Immensus Pater, immensus Filius :

inaugural exposition by Hilary must have taken. 4. Again, if Hilary had been the author of the Creed, his name must have commanded respect, and he would scarcely have met with such hard words from Pope Leo I., as may be found in the Epistle to the French Bishops, A.D. 445. On the other hand, the highly probable communication between Victricius and Anastasius, and the preparation of a confession of faith by the Gallican Confessor, indicates the process, whereby the name of Athanasius, by assimilation, may have been placed at length at the head of the Creed. For these reasons, therefore, it is considered, that the authorship of the Creed may be referred to the Confessor Victricius, Bishop of Rouen ; and that the date of the production may be assigned to the year 401."

The question is too large an one to be followed out further in these pages ; and the reader is referred for more detailed information to Waterland's History of the Athanasian Creed, and to the work just quoted. But it may be stated as a result of the critical researches which have been brought to bear on the subject, that this Creed must be regarded as of Gallican origin, and that it was written as we now have it, not later than the middle of the fifth century.

§ Expository Notes on the Athanasian Creed.

Whosoever will be saved, &c. St. Augustine, in his Treatise on Faith and Works, says, "Not only is a good life inseparable from Faith, but Faith itself is a good life." This illustrates the assertion of the Creed that "before all things it is necessary to hold the Catholic Faith." For faith necessarily precedes practice : "without faith it is impossible to please God : for he that cometh to God must believe that He is, and that He is a Rewarder of them that diligently seek Him." [Heb. xi. 6.] Now the belief that "God is," includes far more than a mere assent to the fact of His existence. To a mind capable of logical reflection, many corollaries must necessarily hang on to this fundamental axiom ; the statement of such corollaries forms a more or less developed Creed ; and thus belief in a Creed as the logical extension of the most primary truth, becomes necessary to salvation, or "coming to God," here and hereafter.

whole and undefiled] The sin of not keeping the Catholic Faith whole and undefiled, can only be committed by those who know what it is in its integrity, and wilfully reject some portion of it : "every one" must therefore mean every one who has come to such a knowledge of the Faith, without asserting any thing respecting those who are ignorant of it. This is simply, there-

fore, a declaration that heresy, or a wilful rejection of any part of the Catholic Faith, comes within the condemnation declared by our Lord, "He that believeth not shall be damned." [Mark xvi. 16.] Those are in danger of this condemnation who have learned that there is a Trinity in Unity, Three Persons in One God, and yet wilfully reject the doctrine : but many believe this faithfully who have not sufficient education to follow out the doctrine into its consequences and necessary corollaries, as afterwards stated. On the other hand, those who understand these corollaries and reject them run into practical heresy.

That we worship] The actual sense of this verse may be stated in other words as being, "The Catholic Faith is this, that the God whom we worship, is One God in Trinity, and Trinity in Unity." Yet it is also true that as the end of all right Belief is right Worship, so the worship which alone can be right is that which is founded on the Catholic Faith as here stated.

Persons—Substance] "Person" is a word which marks the individual Unity of the Father, of the Son, and of the Holy Ghost ; "Substance," a word which marks their collective Unity. The latter word, which is synonymous with "Essence," or "Nature," comprehends all the essential qualities of Deity, or that which God is : Eternity, Uncreatedness, Omnipotence, Omnipresence, are some of these essential qualities belonging to Deity, and not belonging to any other kind of being. To "divide the Substance" is to assert that these essential qualities, or any of them, belong to either Person of the Godhead separately from, or in a different degree from, the other Persons.

Sabellius (A.D. 250) originated, in its most definite form, the heresy of "confounding the Persons," by declaring that Father, Son, and Holy Ghost were but three names, aspects, or manifestations of one God. Arius (A.D. 320) "divided the Substance" by alleging that the First Person existed before the other two Persons of the Blessed Trinity ; thus attributing the essential quality of Eternity to One, and denying that it belonged to the others. These two errors lie at the root of all others ; and the following twenty verses of the Creed are an elaboration of the true doctrine, in a strict form of language, as a fence against them.

incomprehensible] This word is represented in modern English by the word Omnipresent. In Bishop Hilsey's translation of the Creed, he uses the word "immeasurable," which better answers to the Latin *immensus*. The word "incomprehensible" has now the disadvantage of a metaphysical as well as a physical sense ; but when the Prayer Book was translated, it

Ps. cxxxix. 7. Son incomprehensible : and the Holy Ghost incomprehensible.

"Immeasurable," Hilsey's Primer, 1539. The Father eternal, the Son eternal : and the Holy Ghost eternal.

Isa. lxiii. 16. Heb. i. 8. ix. 14. Ps. xc. 2. And yet they are not three eternal : but one eternal.

Jer. xxiii. 24. Isa. vi. 3. Exod. iii. 14. As also there are not three incomprehensibles, nor three uncreated : but one uncreated, and one incomprehensible.

Job xxxiii. 4. Rev. i. 8. xv. 3. xix. 6. Matt. xii. 31, 32. Gen. xvii. 1. So likewise the Father is Almighty, the Son Almighty : and the Holy Ghost Almighty.

And yet they are not three Almighty : but one Almighty.

Exod. xx. 2, 3. Eph. i. 3. 1 Tim. iii. 16. Acts v. 3, 4. So the Father is God, the Son is God : and the Holy Ghost is God.

And yet they are not three Gods : but one God.

Matt. xi. 25. Acts x. 36. 2 Cor. iii. 17. Zech. xiv. 9. So likewise the Father is Lord, the Son Lord : and the Holy Ghost Lord.

And yet not three Lords : but one Lord.

For like as we are compelled by the Christian verity : to acknowledge every Person by himself to be God and Lord ;

Deut. vi. 4. Eph. iv. 5, 6. So are we forbidden by the Catholick Religion : to say, There be three Gods, or three Lords.

John v. 26. The Father is made of none : neither created, nor begotten.

John v. 26. Heb. i. 5. The Son is of the Father alone : not made, nor created, but begotten.

John xiv. 26. xv. 26. The Holy Ghost is of the Father, and of the Son, : neither made, nor created, nor begotten, but proceeding.

So there is one Father, not three Fathers ; one Son, not three Sons :

immensus Spiritus Sanctus.

Salisbury Use.

Æternus Pater, æternus Filius, æternus Spiritus Sanctus.

Et tamen non tres æterni sed unus æternus.

Sicut non tres increati, nec tres immensi : sed unus increatus, et unus immensus.

Similiter omnipotens Pater, omnipotens Filius : omnipotens Spiritus Sanctus.

Et tamen non tres omnipotentes : sed unus omnipotens.

Ita Deus Pater, Deus Filius : Deus Spiritus Sanctus.

Et tamen non tres Dii : sed unus est Deus.

Ita Dominus Pater, Dominus Filius : Dominus Spiritus Sanctus.

Et tamen non tres Domini : sed unus est Dominus.

Quia sicut singillatim unamquamque Personam Deum et Dominum confiteri Christiana veritate compellimur :

Ita tres Deos aut Dominos dicere, catholica religione prohibemur.

Pater a nullo est factus : nec creatus, nec genitus.

Filius a Patre solo est : non factus, nec creatus, sed genitus.

Spiritus Sanctus a Patre et Filio : non factus, nec creatus, nec genitus, sed procedens.

Unus ergo Pater, non tres Patres ; unus Filius, non tres Filii ; unus Spi-

probably had only the latter meaning, expressing "that which cannot be grasped by, or contained within, any space." It is only a strict form of stating the primary notion that "God is every where." "If I climb up into Heaven, Thou art there : if I go down into hell, Thou art there also. If I take the wings of the morning : and remain in the uttermost parts of the sea ; Even there also shall Thy hand lead me : and Thy right hand shall hold me." (Ps. cxxxix. 7-9.) Yet it is true that a meaning not intended in the Creed has developed itself through this change of language, for the Nature of God is as far beyond the grasp of the mind, as it is beyond the possibility of being contained within local bounds.

For like as we are compelled, &c.] The Creed here declares the Divinity of each several Person, of the Blessed Trinity to be so clearly set forth in "the Christian Verity," that is in the Canon of Holy Scripture as received by the Church, that there is no escape for the reason from such a conclusion ;—we are compelled to believe, by the force of the evidence which God has vouchsafed us in the Holy Bible. It would be easy to show, at length, how literally true this is ; but the marginal references appended to the text are intended to direct the reader to such

evidence, and to supersede, by his private study, the necessity for occupying space here with the details of the Scriptural argument.

So are we forbidden by the Catholick Religion, &c.] (1) The evidence of doctrine is contained in the Holy Scriptures ; the consequences, deductions, and inferences, which may be made from the contents of Holy Scripture, must be under the control of the Church. The one teaching us clearly that each Person of the Blessed Trinity possesses in Himself the inherent essential qualities of the Divine Nature, the other forbids us to draw any false conclusions from the truth thus revealed. (2) The final interpretation of Holy Scripture rests not with the individual Christian, but with the collective Christian body ; and where that collective Christian body has set forth an interpretation, the individual Christian will be, to say the least, unsafe in adopting, or wishing to adopt, any other. (3) The "Catholic Religion" respecting the Unity of the Trinity, had been clearly decided and set forth at the General Councils held before this Creed was written.

The Holy Ghost is of the Father, and of the Son] The introduction of the words *et Filio* into this Creed, shows that the

one Holy Ghost, not three Holy Ghosts.

1 Cor. xii. 6. 11.
Col. iii. 11.

And in this Trinity none is afore, or after other : none is greater, or less than another ;

John viii. 58.

But the whole three Persons are co-eternal together : and co-equal.

Matt. iv. 10.
2 Thess. iii. 5.
Rev. iv. 8.

So that in all things, as is aforesaid : the Unity in Trinity, and the Trinity in Unity is to be worshipped.

Mark ix. 24.

He therefore, that will be saved : must thus think of the Trinity.

Heb. ii. 3.
Rom. i. 2, 3, 4.
1 John iv. 3.

Furthermore, it is necessary to everlasting salvation : that he also believe rightly the Incarnation of our Lord Jesus Christ.

1 John ii. 23.
v. 20.
1 Tim. iii. 16.

For the right Faith is, that we believe and confess : that our Lord Jesus Christ, the Son of God, is God and Man ;

Gal. iv. 4.
Col. i. 17. ii. 9.
Luke ii. 6, 7, 11.

God, of the substance of the Father, begotten before the worlds : and Man, of the substance of his Mother, born in the world ;

John i. 1. 14.
Heb. i. 8. ii. 14.
16.
Luke ii. 52. xxiv.
39.

Perfect God, and perfect Man : of a reasonable soul and human flesh subsisting.

ritus Sanctus, non tres Spiritus Salisbury Usa. Sancti.

Et in hac Trinitate nihil prius aut posterius : nihil majus aut minus.

Sed totæ tres personæ : coæternæ sibi sunt et coæquales.

Ita ut per omnia, sicut jam supra dictum est, et Unitas in Trinitate : et Trinitas in Unitate veneranda sit.

Qui vult ergo salvus esse : ita de Trinitate sentiat.

Sed necessarium est ad æternam salutem : ut incarnationem quoque Domini nostri Jesu Christi fideliter credat.

Est ergo fides recta, ut credamus et confiteamur : quia Dominus noster Jesus Christus, Dei Filius, Deus et homo est.

Deus est ex substantia Patris ante sæcula genitus : et homo est ex substantia matris in sæculo natus.

Perfectus Deus, perfectus homo : ex anima rationali et humana carne subsistens.

doctrine of the Double Procession of the Holy Ghost was received at a very early date, although "Filioque" was not inserted in the Nicene Creed until the sixth century. The statement of it in this place is of a more general character than in the Nicene Creed [q. v.], but it is rejected by the Eastern Church.

He therefore, that will be saved, must thus think of the Trinity] This practical or saving importance of a right Faith in the Holy Trinity, may be seen (1) from the manner in which the doctrine lies at the foundation of all other doctrine ; (2) by the fact that our Lord made it the very fountain of spiritual life, when He connected the invocation of the Holy Trinity essentially with Holy Baptism ; and (3) by the place which it occupies in moulding all the forms of Christian worship.

Nevertheless, this verse of the Creed must not be taken as meaning that no person can be saved except he has an intellectual apprehension of the doctrines here set forth about the Blessed Trinity. Intellectual apprehension of doctrine is confined to educated minds, which have the faculty of forming opinions about truth, as well as of believing it. In whatever degree, then, *opinions* accompany *Faith*, they must be consistent with the statements here made respecting God, in each several Person, and in one Indivisible Trinity. It is one of the responsibilities attached to the possession of intellect, and its development by education, that it be not suffered to go out of its province, professing to *discover* where it cannot even *observe*, or to reason where it has no premisses. The highest intellect cannot form any opinion about God that can possibly be true, if it is not consistent with what He Himself has told us ; and the highest operation of intellect is to train itself into consistency with the Supreme Mind.

Furthermore, it is necessary to everlasting salvation] The latter part of the Athanasian Creed may be said to be a logical exposition of the second member of the Apostles' Creed, and especially with reference to the two Natures of our Blessed Lord, the union of which is called the "Incarnation."

God, of the Substance of the Father] The many heresies respecting the Nature of our Blessed Lord entailed on the Church a necessity for the greatest strictness of expression ; and whether God the Son was *of the same Substance* with the Father, eternally begotten, or whether He was *of a similar Substance*, and a created being, was the great question which had to be decided by the Church, time after time, as one form and another of the latter opinion arose, throughout the first ages. The voice of the Church never faltered, but always declared that the belief here expressed was the Faith once for all delivered to the Saints, and handed down from the Apostles to later times. It was this contest of heresy with the orthodox faith that originated the minute definition into which the Athanasian Creed runs ; and however unnecessary it may seem to those who willingly receive the true doctrine, yet it must be remembered that heresy never dies ; and that hence this minute accuracy is a necessary bulwark of the truth. Also, that we may be very thankful "the right Faith" has not now to be built up, but only to be defended.

Perfect God, and perfect Man] Our Lord Jesus, in both of His two Natures, has all the essential qualities which belong to each : Eternity, Uncreatedness, Omnipresence, Almightyness, Divine Will, and all other attributes of the Divine Nature ; Body, Soul, Human Will, and all other attributes belonging to the Human Nature. These two Natures are as entirely united in the One Person Christ, as the body and the soul are united in the one person man. This Union was first effected when the Son of God began to be the Son of Man in the womb of the Blessed Virgin Mary, and it has never been broken since. When the Body of the Crucified Saviour was laid in the tomb, it was kept from corruption by the continuance of its Union with the Divine Nature ; and when His Soul descended into hell, the Divine Nature was still united to it also, enabling it to triumph over Satan and Death ; when the Soul and Body of Christ were united together again, and ascended into Heaven, it was in conjunction with the Divine Nature that they ascended, to sit as Per-

Equal to the Father, as touching his Godhead ; and inferior to the Father, as touching his Manhood.

Who although he be God and Man ; yet he is not two, but one Christ ;

One ; not by conversion of the Godhead into flesh ; but by taking of the Manhood into God ;

One altogether ; not by confusion of Substance ; but by unity of Person.

For as the reasonable soul and flesh is one man ; so God and Man is one Christ ;

Who suffered for our salvation ; descended into hell, rose again the third day from the dead.

He ascended into heaven, he sitteth on the right hand of the Father, God Almighty ; from whence he shall come to judge the quick and the dead.

At whose coming all men shall rise again with their bodies ; and shall give account for their own works.

And they that have done good shall go into life everlasting ; and they that have done evil into everlasting fire.

This is the Catholick Faith ; which, except a man believe faithfully, he cannot be saved.

Glory be to the Father, and to the Son ; and to the Holy Ghost ;

As it was in the beginning, is now, and ever shall be ; world without end. Amen.

Zech. xiii. 7.
John x. 30. xiv. 28.
Phil. ii. 5-7.
Matt. xvi. 16.
Phil. ii. 7.
Heb. ii. 17.
1 Tim. ii. 5.
John xi. 27.
Gal. iii. 16.
Isa. liii. 4. 8. 10.
Luke xxiii. 42, 43.
1 Cor. xv. 3, 4.
Luke xxiv. 51.
1 Pet. iii. 21, 22.
1 Thess. iv. 16.
2 Thess. i. 7-10.
Job xix. 25-27.
Isa. xxvi. 19.
2 Cor. v. 10.
Matt. xvi. 27.
xxv. 34-46.
Dan. xii. 2.
2 Thess. ii. 15.
Jude 3.
1 John v. 12. ii. 23.
Mark xvi. 16.

Æqualis Patri secundum Divinitatem: minor Patre secundum Humanitatem.

Qui licet Deus sit et Homo: non duo tamen, sed unus est Christus.

Unus autem, non conversione Divinitatis in carnem: sed assumptione humanitatis in Deum.

Unus omnino, non confusione substantiæ: sed unitate personæ.

Nam sicut anima rationalis et caro unus est homo: ita Deus et Homo unus est Christus,

Qui passus est pro salute nostra, descendit ad inferos: tertia die resurrexit a mortuis.

Ascendit ad cœlos, sedet ad dexteram Dei Patris omnipotentis: inde venturus est judicare vivos et mortuos.

Ad cujus adventum omnes homines resurgere habent cum corporibus suis: et reddaturi sunt de factis propriis rationem.

Et qui bona egerunt ibunt in vitam æternam: qui vero mala in ignem æternum.

Hæc est fides catholica: quam nisi quisque fideliter firmiterque crediderit, salvus esse non poterit.

Gloria Patri, et Filio: et Spiritui Sancto.

Sicut erat in principio, et nunc et semper: et in sæcula sæculorum.

Salisbury Use.
At. ad dext. Patris, inde

fect God and Perfect Man at the right hand of the Father. And in the same two, but united Natures, Christ our Lord will come to judge the quick and the dead.

life everlasting—everlasting fire] These words, awful as the latter part of them is, are the words of our Lord, “The King shall say unto them on His right hand, Come, ye blessed of My Father, inherit the kingdom prepared for you from the foundation of the world. also unto them on the left hand, Depart from Me, ye cursed, into everlasting fire, prepared for the devil and his angels And these shall go away into everlasting punishment; but the righteous into life eternal.” (Matt. xxv. 34, 41, 46.)

This is the Catholick Faith: which except a man believe faithfully, he cannot be saved] This verse also is founded on words of our Lord, “He that believeth and is baptized shall be saved; but he that believeth not shall be damned.” (Mark xvi. 16.) And these severe words of His are the more striking from the fact of their utterance immediately before His Ascension to Heaven, lifting up His hands, and blessing His disciples.

It will be observed that the word *firmiter* in this clause is not represented in our translation. Waterland says [Critic. Hist. V. x.] that our translators followed a Greek copy of the Creed, printed at Basle by Nicholas Bryling. As this was reprinted by

Stephens in 1565, it probably had some weight at the time. These words of the clause in this Greek copy are given as *πιστῶς πιστεύσῃ*. Other Greek copies follow the Latin.

It does not become the writer to say any thing that may in the least lessen the force of such awful words. In the Creed which has been under notice, they are applied in close consistency with our Lord’s first use of them, and they must be taken for all that they fairly mean. A word of caution may, however, be expedient; reminding the reader of what has been before said about opinion and belief. A willing assent may be given to the more obvious statements of this Creed, by many who are quite unable to enter upon the collateral and inferential statements deduced from them; and “a man” may thus “believe faithfully” in the substantial truths of the Catholic Faith. With an expanded knowledge, an expanded faith is necessary: and all the statements of the Creed are so bound together, that they whose expanded knowledge of it is not thus accompanied, are in fact rejecting the fundamental Articles of the Faith, as well as those that seem subordinate only. It will be better in the next life for the ignorant, if they have believed according to the measure of their knowledge, than for those who have known much, but have believed little.

AN INTRODUCTION TO THE LITANY.

THE Greek word *Litaneia*, meaning Prayer or Supplication, appears to have been used in the fourth century for devotions public or private; but it soon came to have a narrower and more technical sense as applied to solemn acts of processional prayer. Whether St. Basil uses it in this sense, when in his 107th epistle he reminds the clergy of Neocæsarea that "the Litanies which they now practise" were unknown in the time of their great apostle Gregory, and therefore might form a precedent for other salutary innovations, is a matter of opinion, on which Bingham and Mr. Palmer (the latter more expressly than the former) take the affirmative side, the Benedictine Editor and Mr. Keble [note to Hooker's E. P. v. 41. 2] taking the negative. But when we are told [Mansi, Concil. iv. 1428] that the aged abbat Dalmatius had for many years never left his monastery, though repeatedly requested by Theodosius II. when Constantinople was visited by earthquakes, "to go forth and perform a Litany," there can be no doubt as to the meaning of the statement.

The history, however, of Litanies, in the proper sense of the term, is rather Western than Eastern. We find indeed, in the Eastern Liturgy and Offices, some four or five specimens of a kindred form of prayer, called *Ectene*, *Synapte*, &c., in which the Deacon bids prayer for several objects, sometimes beginning with "In peace let us beseech the Lord," and the people respond with "Kyrie eleison," or with "Vouchsafe, O Lord." The reader of Bishop Andrewes' Devotions will be familiar with this type of prayers [see Oxford edition, pp. 5. 92]. And we have it represented, in the Western Church, by two sets of "Preces" in the Ambrosian Missal, one used on the first, third, and fifth Sundays in Lent, the other on the second and fourth. One of these begins, "Beseeching the gifts of Divine peace and pardon—we pray Thee," &c., proceeding to specify various topics of intercession, with the response, "Lord, have mercy." The other is shorter, but in its imploring earnestness, ("Deliver us, Thou who deliveredst the children of Israel—with a strong arm and a high hand—O Lord, arise, help us, and deliver us for Thy Name's sake,") is even more interesting as a link between the Ectene and the Litanies of the West, an essential characteristic of which is their deprecatory and more or less penitential tone. Somewhat similar are the Mozarabic "Preces" for Lenten Sundays, with their burdens of "Have mercy," "We have sinned," &c. We may also observe that "Preces," like the "Pacifica" of the Ambrosian rite, were anciently sung at Mass in Rome, (at first only on days when the Gloria in Excelsis and Alleluia were omitted,) until the ninth century. They formed an Eastern feature in the service, and may be compared with the Preces of the Abbey of Fulda, which like a Greek Ectene, intercede for various persons and classes, supplicate for a Christian and peaceful end, and have for their responses, "We pray Thee, O Lord, hear and have mercy," "Grant it, O Lord, grant it:" also with a series of invocations, followed by "Tu illum adjuva," occurring in an old form for an Emperor's coronation in Muratori, Lit. Rom. ii. 463.

But to confine ourselves to the Western Litany. It became common among the Gallic churches in the fifth century, as it was in the East, to invoke the Divine mercy in time of excessive rain or drought, by means of Rogations or processional supplications. But these, according to the testimony of Sidonius Apollinaris [v. 14], were often carelessly performed, with lukewarmness, irregularity, and infrequency—devotion, as he expresses it, being often dulled by the intervention of meals. The shock of a great calamity wrought a change and formed an epoch. The illustrious city of Vienne, already famous in Christian history for the persecution under M. Aurelius [Euseb. v. 1], was troubled for about a year—probably the year 467-8 [Fleury, xxix. c. 38]—with earthquakes. In the touching language of Gregory of Tours [Hist. Francor. ii. 34] the people had hoped that the Easter festival would bring a cessation of their distress. "But during the very vigil of the glorious night, while Mass was being celebrated," the

palace took fire, the people rushed wildly out of the church, and the bishop Mamertus was left alone before the altar, entreating the mercy of God. He formed then a resolution, which he carried out in the three days before the Ascension festival, of celebrating a Rogation with special solemnity and earnestness. A fast was observed, and with prayers, psalmody, and Scripture lessons, the people went forth in procession to the nearest church outside the city. Mamertus, says Fleury, had so appointed, "voulant éprouver la ferveur du peuple . . . mais le chemin parut trop court pour la dévotion des fidèles." Sidonius imitated this "most useful example" in Auvergne, at the approach of the Goths. He tells Mamertus [vi. ep. i.] that the Heart-searcher caused the entreaties made at Vienne to be a model for imitation and a means of deliverance. Gregory of Tours writes that these Rogations were "even now celebrated throughout all churches with compunction of heart and contrition of spirit;" and tells how St. Quintianus in Auvergne, celebrating one in a drought, caused the words "If the heaven be shut up," &c. [2 Chron. vi. 26], to be sung as an anthem, whereupon at once rain fell; how king Guntram ordered a Rogation, with fasting on barley-bread and water, during a pestilence [Hist. Fr. ix. 21]; how St. Gall instituted Rogations in the middle of Lent [ib. iv. 5]; how the bishop of Paris performed them before Ascension, "going the round of the holy places" [ix. 5]. St. Casarius of Arles [A.D. 501—542], in his Homily "de Letania" (it became usual so to spell the word) calls the Rogation days "holy and spiritual, full of healing virtue to our souls," and "regularly observed by the Church throughout the world;" and bids his hearers come to church and stay through the whole Rogation service, so as to gain the full benefit of this "three days' healing process."

In order to estimate the comfort which these services then gave, one must take into account not only such afflictions as drought or pestilence, but the painful sense of confusion and insecurity which in those days brooded over Western Europe, and which still speaks in some of our own Collects, imploring the boon of peace and safety. We cannot wonder that, while the Rogation Mass in the Old Gallican Missal speaks of "sowing in tears, to reap in joys," a Collect in the Gallican Sacramentary "in Letanias," dwells on "the crash of a falling world." So it was that, as Hooker expresses it, "Rogations or Litanies were then the very strength, stay, and comfort of God's Church." Council after Council,—as of Orleans in 511, Gerona in 517, Tours in 567,—decreed Rogation observances in connexion with a strict fast. But the Spanish Church, not liking to fast in the Paschal time, placed its Litanies in Whitsun-week and in the autumn, while the Milanese Rogations were in the week after Ascension. We learn from the Council of Cloveshoo in 747, that the English Church had observed the Rogations before Ascension ever since the coming of St. Augustine: and the anthem with which he and his companions approached Canterbury, "We beseech Thee (*deprecamur* te), O Lord, in Thy great mercy, to remove Thy wrath and anger from this city, and from Thy holy house, for we have sinned, Alleluia," was simply part of the Rogation Tuesday service in the church of Lyons [Martene, de Ant. Eccl. Rit. iii. 529]. This urgent deprecatory tone, this strong "crying out of the deep," which expresses so marked a characteristic of the Litanies, appears again in another Lyons anthem for Rogations, "I have seen, I have seen the affliction of My people;" in the York suffrage, which might seem to be as old as the days of the dreaded heathen king Penda, "From the persecution by the Pagans and all our enemies, deliver us;" and yet more strikingly in the Ambrosian, "Deliver us not into the hand of the Heathen: Thou art kind, O Lord, have pity upon us; encompass Thou this city, and let Angels guard its walls; mercifully accept our repentance, and save us, O Saviour of the world; In the midst of life we are in death:" although this latter anthem, so familiar to us, was composed on a different

occasion by Notker of St. Gall [see Notes to Burial Office]. The strict rule which forbade in Rogation time all costly garments, and all riding on horseback, may be illustrated by the decree of the Council of Mayence in 813, that all should "go barefoot and in sackcloth in the procession of the Great Litany of three days, as our holy fathers appointed."

This name, "Litania Major," was thus applied in Gaul to the Rogations, but in Rome it has always been used (as it now is throughout the Roman Church) for the Litany of St. Mark's day, which traces itself to St. Gregory the Great, and of which the *Ordo Romanus* says that it is not "in jejuniis." In order to avert a pestilence, Gregory appointed a "sevenfold Litany," using the term for the actual processional company, as the Litany of clergy, the Litany of laymen, that of monks, of virgins, of married women, of widows, of the poor and children; and, in fact, the Roman bishops did not adopt the Rogation Litany, properly so called, until the pontificate of Leo III., which began in 795. This was some fifty years after England, on the other hand, had adopted the Litany of St. Mark's day as that which at Rome was called the Greater.

But although in strictness, as Hugh Menard says, "*Litania ad luctum pertinet*," the Litany was not always confined to occasions of distress or of special humiliation. As early as the close of the fifth century, the Gelasian Sacramentary, in its directions for Holy Saturday, had the following [Muratori, i. 546. 568]:—"They enter the sacristy, and vest themselves as usual. And the clergy begin the Litany, and the Priest goes in procession, with those in holy orders, out of the sacristy. They come before the altar, and stand with bowed heads until they say, 'Lamb of God, who takest away the sins of the world.'" Then comes the blessing of the Paschal taper; and after the series of lessons and prayers which follows it, they go in procession with a Litany to the fonts, for the baptisms: after which they return to the Sacristy, "and in a little while begin the third Litany, and enter the church for the Vigil Mass, as soon as a star has appeared in the sky."

And so it became natural to adopt a form of prayer which took so firm a hold of men's affections, on various occasions when processions were not used. At ordinations, or at consecrations, at the conferring of monastic habits, at coronations of Emperors, at dedications of churches, &c., it became common for the "school," or choir, to begin, or as it was technically called, to "set on" (imponere) the Litany,—for the Subdeacon to "make the Litanies,"—for the first of the Deacons to "make the Litany," that is, to present its suffrages, [Murat. ii. 423. 426. 439. 450. 452. 455. 467.] beginning with "Kyrie eleison," or with "O Christ, hear us." A Litany never came amiss: it was particularly welcome as an element of offices for the sick and dying: its terseness, energy, pathos, seemed to gather up all that was meant by "being instant in prayer."

For some time the Litanies were devoid of all invocations of Angels and Saints. The Preces of Fulda simply asked God that the Apostles and Martyrs might "pray for us." But about the eighth century invocations came in. A few Saints are invoked in an old Litany which Mabillon calls Anglo-Saxon, [Vet. Anal. p. 163.] and Lingard Armoricant [Angl. Sax. Ch. ii. 386]. Names of Angels, with St. Peter or any other Saint, occur in another, which Mabillon ascribes to the reign of Charlemagne. The Litany in the *Ordo Romanus* [Bib. Vet. Patr. viii. 451] has a string of saintly names. As the custom grew, more or fewer Saints were sometimes invoked according to the length of the procession; "quantum sufficit iter," says the Sarum Processional; and the York, "secundum exigentiam itineris." The number was often very considerable: a Litany said after Prime at the venerable abbey of St. Germain des Près had, Martene says [iv. 49], ninety-four saints originally: an old Tours form for visitation of the sick has a list of saints occupying more than four columns [ib. i. 859]: and a Litany of the ninth century which Muratori prints, as "accommodated to the use of the church of Paris," has one hundred and two such invocations [Mur. i. 74]. The invocations generally came between the Kyrie, &c. at the beginning, and the Deprecations which, in some form or other, constituted the most essential element of the Litany. Mr. Palmer thinks

that the space thus occupied had once been filled by many repetitions of the Kyrie, such as the Eastern Church loved, and the Council of Vaison in 529 had recommended; and in consequence of which St. Benedict had applied the name of Litany to the Kyrie, just as, when invocations had become abundant, the same name was popularly applied to them, which explains the plural form, "*Litaniæ Sanctorum*," in Roman books. Sometimes we find frequent Kyries combined with still more frequent invocations, as in a Litania Septena for seven subdeacons on Holy Saturday, followed by a Litania Quina and Terna [Mart. i. 216]. A Litania Septena was used on this day at Paris, Lyons, and Soissons.

The general divisions of Mediæval Litanies were, 1. Kyrie, and "Christ, hear us," &c. 2. Entreaties to each of the Divine Persons, and to the whole Trinity. 3. Invocations of Saints. 4. Deprecations. 5. Obsecrations, "by the mystery," &c. 6. Petitions. 7. Agnus Dei, Kyrie, Lord's Prayer. 8. Collects.

The present Roman Litany should be studied as it occurs in the Missal, on Holy Saturday; in the Breviary, just before the *Ordo Commendationis Animæ*; and in the Ritual, just before the Penitential Psalms:—besides the special Litany which forms part of the Commendatio. The Litany of Holy Saturday is short, having three deprecations and no Lord's Prayer. The ordinary Roman Litany, as fixed in the 16th century, names only fifty-two individual Saints and Angels. It is said on St. Mark's day, and during Lent, in choir, and "extra chorum pro opportunitate temporis."

The Litanies of the mediæval English Church are a truly interesting subject. Mr. Procter, in his History of the Common Prayer, p. 251, has printed a Litany much akin to the Litany of York, and considered by him to be of Anglo-Saxon date. The Breviaries and Processionals exhibit their respective Litanies: and the ordinary Sarum Litany used on Easter Eve, St. Mark's day, the Rogations, and every week-day in Lent, (with certain variations as to the Saints invoked,) occurs in the Sarum Breviary just after the Penitential Psalms. It is easy, by help of the Processionals, to picture to oneself the grandeur of the Litany as solemnly performed in one of the great churches which followed the Sarum or York rites. Take for instance Holy Saturday. The old Gelasian rule of three Litanies on that day was still retained. In Sarum, a "Septiform Litany" was sung in the midst of the choir by seven boys in surplices; (compare the present Roman rubric, that the Litany on that day is to be sung by two chanters "in medio chori;") the York rubric says, seven boys, or three where more cannot be had, are to sing the Litany. It was called septiform, because in each order of saints, as apostles, martyrs, &c., seven were invoked by name. After "All ye Saints, pray for us," five deacons began the "Quinta-partita Letania" in the same place (the York says, "*Letaniam puerorum sequatur Letania diaconorum*"): but after "St. Mary, pray for us," the rest was said in solemn procession to the font, starting "ex australi parte ecclesiæ." First came an acolyte as cross-bearer, then two taper-bearers, the censer-bearer, two boys in surplices with book and taper, two deacons with oil and chrism, two subdeacons; a priest in red cope, and the five chanters of the Litany. In these two Litanies the four addresses to the Holy Trinity were omitted. After the blessing of the font, three clerks of higher degree in red copes began a third Litany, the metrical one which, Cassander says, was called *Litania Norica*, "*Rex sanctorum Angelorum, totum mundum adjuva*;" (with which may be compared, as being also metrical, what Gibbon, vol. vii. p. 76, calls the "fearful Litany" for deliverance from the arrows of Hungarians:) after the first verse was sung, the procession set forth on its return. In York, the third Litany was sung by three priests, and was not metrical. There were processions every Wednesday and Friday in Lent (on other Lenten week-days the Litany was non-processional), the first words of the Litany being sung "before the altar, before the procession started" [Process. Sar.], and the last invocation being sung at the steps of the choir as it returned. In York, on Rogation Tuesday, the choir repeated after the chanter, processionally, the Kyrie and *Christe eleison* with the Latin equivalents, "*Domine, miserere; Christe, miserere*;" then, "*Miserere nobis, pie Rex, Domine Jesu Christe.*" The

responses in this Litany were curiously varied. The chanter said, for instance, "St. Mary, pray for us;" and the choir responded, "Kyrie eleison." Again, "St. Michael, pray for us;" the response was, "Christ, hear us." The York Litany of Ascension Eve has, "Take away from us, O Lord, our iniquities," &c., the response being a repetition of the first words. Then, "Have mercy, have mercy, have mercy, Lord, on Thy people," &c., the response being "Have mercy;" then "Hear, hear, hear our prayers, O Lord:" response, "Hear." The rubric adds, "Et dicatur Letania per circuitum ad introitum chori." On the same Eve, in Sarum, a metrical invocation to St. Mary was chanted, "Sancta Maria, Quæsumus, alnum Poscere Regem Jure memento; Salvete omnes Nos jubilantes." On St. Mark's day, in Sarum, as in the Rogation Litany of York above quoted, the suffrage included "pray for us," and the response was Kyrie. The Sarum rule was, "Whatever part of the Litany is said by the priest must be fully and entirely repeated by the choir, as far as the utterance of 'We sinners beseech Thee to hear us.' For then after 'That Thou give us peace,' the choir is to respond 'We beseech Thee, hear us:' and after each verse, down to 'Son of God.'" So the Processional; and the same rule is given, in somewhat different form, by the Breviary.

Besides the Latin Litanies for church use, the Primer contained one (in English) which may be seen in Mr. Maskell's second volume of "Monumenta Ritualia," where he exhibits a Sarum Primer of about A.D. 1400; with two other English Litanies from MSS. in the Bodleian. A MS. English Litany of the 15th century, somewhat different from these, is in the Library of University College, Oxford.

Coming down to the 16th century, we find the first form of our present Litany in that of 1544, probably composed by Cranmer, who would have before him the Litany in the Goodly Primer of 1535, and perhaps the Cologne Litany published in German 1543, or Luther's of 1543: and it was imposed on the Church by Henry VIII., to be used "in the time of processions." It retains three invocations of created beings: one addressed to "St. Mary, Mother of God our Saviour;" a second to the "holy Angels, Archangels, and all holy orders* of blessed spirits;" a third to the "holy patriarchs, prophets, apostles, martyrs, confessors, virgins, and all the blessed company of heaven." In Henry's reign there was also a Litany published in the King's Primer of 1545. It is curious that "procession," in Cranmer's language (see a passage in "Private Prayers," Parker Soc., pref. p. 25), meant the actual supplication; and so in King Henry's. In 1547 the Injunctions of Edward VI. forbade processions (in the common sense of the word); and, borrowing part of the Sarum rule above mentioned as to the Easter Eve Litania Septiformis, ordered the priests, with other of the choir, to kneel in the midst of the church immediately before High Mass, and sing or say the Litany, &c., which Injunction was repeated by Queen Elizabeth in 1559, with the alteration of "before Communion," &c. In the Prayer Book of 1549 the Litany was ordered to be said or sung on Wednesdays and Fridays, and was printed after the Communion; but in the Book of 1552 it was printed in its present place, "to be used on Sundays, Wednesdays, Fridays, and at other times," &c. About Christmas, 1558, Elizabeth sanctioned the English Litany nearly as before, for her own Chapel (see Cardwell, Docum. Ann. i. 209, and Lit. Services, Parker Soc., p. xii); it soon came into more general use, and was inserted in the Prayer Book of 1559, the rubric of 1552 being repeated. The Injunctions of Elizabeth in 1559 ordered the Curate to "say the Litany and prayers" in church every Wednesday and Friday; but the Litany of the procession, in Rogation week, was to be continued also, and the custom of "Beating the Bounds" of parishes on Ascension Day still in some sort represents it. [See Note on Rogation Days.]

The fifteenth canon of 1604 provides for the saying of the Litany in church after tolling of a bell, on Wednesdays and Fridays. In the last review of the Prayer Book, the words "to be sung or said" were substituted for "used," (both phrases having occurred in the Scotch Prayer Book,) and are very carefully added,—an erasure being made to give precedence to the word

"sung,"—in Cosin's Durham Book. The Litany was sung by two bishops at the coronation of George I.

With regard to the *place* for saying or singing the Litany, the present Prayer Book in its rubric before the 51st Psalm in the Communion, appears implicitly to recognize a peculiar one, distinct from that in which the ordinary offices are performed. As we have seen, the Injunctions of Edward, followed herein by those of Elizabeth, specified the midst of the church: and Bishop Andrewes had, in his chapel a *faldistory* (folding-stool) for this purpose, between the western stalls and the lectern. So Cosin, as archdeacon of the East Riding in 1627, inquired whether the church had "a little faldstool or desk, with some decent carpet over it, in the middle alley of the church, whereat the Litany may be said after the manner prescribed by the Injunctions;" and in his first series of Notes on the Common Prayer he says, "The priest goeth from out his seat into the body of the church, and at a low desk before the chancel door, called the faldstool, kneels, and says or sings the Litany. *Vide Proph. Joel de medio loco inter porticum et altare,*" &c. Compare also the frontispiece to Bp. Sparrow's Rationale, and to the Litany in Prayer Books of 1662, &c. Cosin gave such a faldstool to Durham Cathedral, which is constantly used by two priests; and the rubric of the present Coronation office speaks of two bishops kneeling in the same manner at a faldstool to say the Litany. The custom doubtless signified the deeply supplicatory character of this service. Finally, in the Durham Book the Rubric before the Litany ends with these words: "the Priest (or Clerks) kneeling in the midst of the Quire, and all the people kneeling, and answering as followeth."

In the present day there is a disposition to make the Litany available as a separate service. Abp. Grindall's order in 1571, forbidding any interval between Morning Prayer, Litany, and the Communion Service, was far from generally observed¹. At Winchester and Worcester Cathedrals the custom of saying the Litany some hours after Mattins has prevailed: and we learn from Peck's *Desiderata Curiosa*, [lib. xii., no. 21,] that in 1730 the members of Ch. Ch. Oxford, on Wednesdays and Fridays, went to Mattins at 6, and to Litany at 9. The 15th canon, above referred to, recognizes the Litany as a separate office. Freedom of arrangement in this matter is highly desirable: and if it be said that the Litany ought to *precede* the Communion, according to ancient precedent, instead of being transferred, as it sometimes now is, to the afternoon, it may be replied that the Eucharistic Ectene of the East is not only much shorter than our Litany, but far less plaintive, so to speak, in tone, and therefore more evidently congruous with Eucharistic joy. The like may be said, on the whole, of the "Preces Pacificæ" once used at Rome (as we have seen) in the early part of the Mass, and at Milan on Lenten Sundays: although indeed a *Lenten* Sunday observance could be no real precedent for all the Sundays in the year². Of the Puritan cavils at the Litany, some will be dealt with in the Notes. One, which accuses it of perpetuating prayers which had but a temporary purpose, is rebuked by Hooker [v. 41. 4], and is not likely to be revived. He takes occasion to speak of the "absolute (i. e. finished) perfection" of our present Litany: Bp. Cosin, in his *Devotions*, uses the same phrase, and calls it "this principal, and excellent prayer" (*excellent* being, in the English of his day, equivalent to matchless); and Dr. Jebb describes it as "a most careful, luminous, and comprehensive collection of the scattered treasures of the Universal Church" [Choral Service, p. 423].

It has clearly two main divisions: I. From the beginning to the last Kyrie, before the Lord's Prayer. This part, says Bp. Sparrow, may be considered as less solemnly appropriated to the priest than the second part: and in some choirs a lay-clerk chants it along with the priest. II. From the Lord's Prayer to the end. The first part may be regarded as having five, the second part four, subdivisions.

¹ In fact there is a direction exactly opposite in an Occasional Service of Queen Elizabeth's reign, exhorting the people to spend a quarter of an hour or more in private devotion between Morning Prayer and the Communion.

² See also a note on the expanded Kyrie Eleison in the Communion Service.

THE LITANY.

¶ Here followeth the Litany, or General Supplication, to be sung or said after Morning Prayer upon Sundays, Wednesdays, and Fridays, and at other times when it shall be commanded by the Ordinary.

Matt. vi. 9. 14.
Luke xv. 18, 19.
Lam. iii. 19, 20.
Rev. iii. 17.

O GOD the Father, of heaven : have mercy upon us miserable sinners.

O God the Father, of heaven : have mercy upon us miserable sinners.

John v. 23.
Isa. xlvi. 17.
* Ps. xix. 15.
Luke xvii. 13.

O God the Son, Redeemer of the world : have mercy upon us miserable sinners.

O God the Son, Redeemer of the world : have mercy upon us miserable sinners.

Acts v. 3. 4.
John xv. 26.
Acts ii. 33. 39.
Rom. viii. 26.

O God the Holy Ghost, proceeding from the Father and the Son : have mercy upon us miserable sinners.

O God the Holy Ghost, proceeding from the Father and the Son : have mercy upon us miserable sinners.

Matt. iii. 16, 17.
xxviii. 19.
2 Cor. xiii. 14.
Micah vii. 18, 19.

O holy, blessed, and glorious Trinity, three Persons, and one God : have mercy upon us miserable sinners.

O holy, blessed, and glorious Trinity, three Persons, and one God : have mercy upon us miserable sinners.

Exod. xx. 5.
Ps. cvi. 6.
Isa. lxiv. 9.
Joel ii. 17.
1 Pet. i. 18, 19.
Ps. xxxix. 13.
Mal. iii. 17.

Remember not, Lord, our offences, nor the offences of our forefathers, neither take thou vengeance of our sins : spare us, good Lord, spare thy people, whom thou hast redeemed with thy most precious blood, and be not angry with us for ever.

Spare us, good Lord.

PATER de cœlis Deus : miserere nobis. Salisbury Use.

Fili Redemptor mundi Deus : miserere nobis.

Spiritus Sancte Deus : miserere nobis.

Sancta Trinitas, unus Deus : miserere nobis.

Here followed the Invocations of Saints, with the Response, "Ora pro nobis," after each.

Ne reminiscaris, Domine, delicta nostra, vel parentum nostrorum : neque vindictam sumas de peccatis nostris. Parce, Domine, parce populo tuo, quem redemisti pretioso sanguine tuo : ne in æternum irascaris nobis.

O God the Father] The old Sarum Litany prefixes to this, "Kyrie eleison, Christe eleison;" then, "Christe, audi nos." The Roman has a complete Kyrie, with "Christe, audi nos; Christe, exaudi nos." The Litany of Ordo Romanus, and the Utrecht Litany, have also "Salvator mundi, adjuva nos." An Ambrosian Baptismal Litany has Kyrie thrice, "Domine miserere" thrice, and "Christe, libera nos" thrice, with the response "Salvator libera nos."

Of heaven] i. e. from heaven, "de cœlis." The phrase comes from Luke xi. 13, ὁ Πατήρ ὁ ἐξ οὐρανοῦ, your Father who heareth from heaven. Cf. 2 Chron. vi. 21. "Exaudi . . . de cœlis," Vulg.

Miserable sinners] Added in 1544.

Proceeding from, &c.] Added in 1544. The Utrecht has, "Spiritus Sancte, benigne Deus."

O holy, blessed, &c.] The address was thus amplified in 1544,

partly from the old Sarum antiphon after the Athanasian Creed, for Trinity week : "O beata et benedicta et gloriosa Trinitas, Pater et Filius et Spiritus Sanctus."

Remember not] Before 1544, these words formed part of the antiphon which was added to the Penitential Psalms as prefixed to the Litany. In the original, after "ne in æternum," &c. came, "et ne des hæreditatem tuam in perditionem: ne in æternum obliviscaris nobis." But there was also, just before the special Deprecations, and after the invocations of Saints, "Propitius esto : Parce nobis, Domine." The word "good" was inserted in 1544. The sins of fathers may be visited on children in temporal judgments. It is much to be observed that the whole of what follows down to the Kyrie, is one continuous act of worship offered to our Blessed Lord; and it is this which gives the Litany such peculiar value in days when His Divinity is too often but faintly realized.

1 Chron. iv. 10. From all evil and mischief; from
Ps. xci. 9, 10, 13. sin; from the crafts and assaults of the
2 Cor. ii. 11. devil; from thy wrath, and from ever-
Rom. i. 18. lasting damnation,
2 Thess. i. 7-9.

Matt. vi. 13. *Good Lord, deliver us.*

2 Cor. iv. 4. From all blindness of heart; from
Gal. v. 26. pride, vain-glory, and hypocrisy; from
1 Pet. ii. 1, 2. envy, hatred, and malice, and all un-
1 John iv. 20. charitableness,

2 Cor. i. 10. *Good Lord, deliver us.*

1 Cor. vi. 8, 9, From fornication, and all other
10. deadly sin; and from all the deceits of
Mark iv. 18, 19. the world, the flesh, and the devil,
1 John ii. 16, 17. Rev. xii. 9.

Good Lord, deliver us.

Ps. xxxix. 8. From lightning and tempest; from
xvi. 1-3. plague, pestilence, and famine; from
1 Kings viii. 37. 39.

Ab omni malo : Libera nos, Domine. Salisbury Use.

Ab insidiis diaboli : Libera

Ab infestationibus dæmonum : Li-
bera

[A ventura ira : Libera] [York Use.]

A damnatione perpetua : Libera

A cæcitate cordis : Libera Salisbury Use.

[A peste superbiæ : Libera] [York Use.]

Ab appetitu inanis gloriæ : Libera Salisbury Use.

Ab ira, et odio, et omni mala volun-
tate : Libera

A spiritu fornicationis : Libera

A fulgure et tempestate : Libera

A subitanea et improvisa morte : Li-
bera

From] These Deprecations, which in the old Litanies, as in the present Roman, were broken up into separate forms, each relating to one topic, were in 1544 combined in groups, as at present; probably in order to give more intensity and energy to the "Deliver us." The like was done with the Obsecrations.

All evil] Sarum, York, Hereford, Carthusian, Dominican, and the old Ordo Romanus; Litania Latina in Luther's Enchiridion, 1543.

Mischief] Added to the old form in 1544.

Sin] Added in 1544, from the Litany in the Primer of 1535. The Roman has it, and it is in Hermann of Cologne's Simplex et Pia Deliberatio, translated from German into Latin in 1545; his Litany is nearly identical with that of Luther named above.

Crafts and assaults] Two distinct modes of diabolic attack, secret and open. "Snares of the devil" are in Ordo Romanus, &c. Compare 2 Cor. ii. 11.

Assaults] Not in York nor in Roman, but in Dominican [Brev. Ord. Prædic.].

Thy wrath] Roman has this; and so the Ordo Romanus. York has, "from the wrath to come." So it is in the Lyons Rogations, and in Carthusian. In Litanies for the Sick it was common to deprecate "Thy wrath" [Martene i. 858, &c.]. The Narbonne had, "From Thy wrath greatly to be feared."

Everlasting damnation] Sarum, Hereford, Utrecht, Cistercian, Dominican have "perpetual" [compare Roman, "a morte perpetua"]. If the force of this Deprecation can be evaded in the interests of Universalism, no words can retain any meaning. York combines "sudden and eternal death."

Blindness of heart] This, which is in Sarum and Utrecht, not in York nor Roman, was derived from the Vulgate of Eph. iv. 18, "propter cæcitatē cordis sui;" but the word *καρπωσι* should rather be rendered "hardness," or "callousness."

Pride] York and Utrecht more emphatically, "the plague of pride." Not in Roman. The Carthusian has, "the spirit of pride."

Vain-glory] Shortened from Sarum, "the desire of vain-glory." Not in Roman.

Hypocrisy] Added in 1544.

Envy] Added in 1544. We do not specify anger, as Sarum and York do.

Hatred] Here Sarum, York, Roman agree.

Malice, &c.] Sarum, York, Roman, Utrecht, Dominican, "all ill-will."

Fornication] Sarum, Roman, Carthusian have "the spirit of fornication;" and Sarum adds, "from all uncleanness of mind and body," which is in Hereford, Utrecht, Carthusian, Dominican;

so York, "from all uncleannesses . . ." Sarum further adds, "from unclean thoughts;" so Dominican.

Deadly sin] In 1544 "all deadly sin." "Other" added in 1549. This phrase has been more than once objected to. The Committee of the House of Lords, in 1641, suggested "grievous sin," doubtless from dislike of the Roman distinction of mortal and venial sins. The Puritan divines, at the Savoy Conference, made a similar suggestion, observing, that the wages of sin, as such, were death. The Bishops answered, "For that very reason, 'deadly' is the better word." They therefore must have understood the phrase to refer to all wilful and deliberate sin. At the same time it must be remembered, that among wilful sins there are degrees of heinousness. "It would be introducing Stoicism into the Gospel, to contend that all sins were equal." [Dr. Pusey's Letter to Bishop of Oxford, p. liii.]

Deceits of the world, the flesh] Added in 1544; but York has "from fleshly desires." So Utrecht, Carthusian, "from wicked concupiscence." "Deceits of the devil," in fact, is a repetition of "crafts of the devil," above. The deceits of the world, of course, mean "the vain pomp and glory" of it, the hollow splendour, the false attractiveness, the promises of satisfaction and of permanence, &c., which, as the Apostle reminds us, have no reality. [1 John ii. 17. Compare 1 Cor. vii. 31.]

Lightning and tempest] Sarum, Roman; not York nor Hereford. Hermann has it; and a Poitiers Litany [Mart. iii. 438] has, "That it may please Thee to turn away *malignitatem tempestatum*." Thunder-storms impelled St. Chad to repair to church, and employ himself in prayer and psalmody; being asked why he did so, he cited Ps. xviii. 13. [Bede iv. 3.] There are two Orations "contra fulgura," and one "ad repellendam tempestatem," in St. Gregory's Sacramentary, ed. Menard.

Plague, pestilence] Sarum, York, Hereford, have not this deprecation, which is in Roman. The Litany of 1535 had "From all pestilence." So also a Tours Litany, "to remove pestilence or mortality from us;" and St. Dunstan's Litany for Dedication of a Church has "From pestilence."

Famine] Not in Sarum, York, Hereford, but in Roman. In 1535, "from pestilence and famine." Dunstan's also, "et fame." The Fleury Litany, in Martene, has "from all want and famine."

Battle] York has, "from persecution by Pagans, and all our enemies," like the Anglo-Saxon Litany. The Roman and Dominican deprecate "war." So Primer of 1535, and Hermann Dunstan's and Fleury mention slaughter.

Eccl. ix. 12.
Ps. xxxix. 5.

battle and murder, and from sudden death,

Isa. xlv. 4.

Good Lord, deliver us.

Ps. lxxiv. 5.
1 Sam. xv. 23.
Gal. v. 19, 20.
2 Tim. iv. 3.
1 Cor. i. 10, iii. 3.
Rom. ii. 4, 5.
Isa. v. 24.

From all sedition, privy conspiracy, and rebellion; from all false doctrine, heresy, and schism; from hardness of heart, and contempt of thy Word and Commandment,

2 Tim. iv. 18.

Good Lord, deliver us.

Matt. i. 21-23.
1 Tim. iii. 16.

By the mystery of thy holy Incarnation; by thy holy Nativity and

Per mysterium sanctæ Incarnationis Salisburie Use.
tuæ: Libera . . .

Murder] Added 1544. Hermann has it. The Latin Book of 1560 has "latrocinio."

Sudden death] This is in the Sarum, "sudden and unforeseen death." York prefixes "sudden" to "eternal death." The Roman agrees with the Sarum. So Hermann, adding "evil." The same deprecation is in the Rogations of Lyons. The Puritans objected that "the godly should always be prepared to die." Hooker replies, in one of his most beautiful and thoughtful chapters [E. P. v. 46], that it is lawful to "prefer one way of death before another;" that it is religion which makes men wish for a "leisurable" departure; that our prayer "importeth a twofold desire," (1) For some "convenient respite;" (2) If that be denied, then, at least, "that although death unexpected be sudden in itself, nevertheless, in regard of our prepared minds, it may not be sudden." Archbishop Hutton, of York, before the Hampton Court Conference was held, explained this as implying a condition, "if it be Thy will," supposing "sudden" were taken simply; but "sudden" might be taken as equivalent to "giving no time for repentance." The aversion of Lord Brook to this deprecation, and his own terrific instantaneous death by a shot from the great spire of Lichfield Cathedral, are well known. In a Prayer Book in the Bodleian, "worn by the daily use" of Bishop Duppa, of Salisbury (while residing at Richmond, between the overthrow of Episcopacy and the Restoration), and containing marginal notes in his own hand, this comment occurs, "Vainly excepted against, because we should always be prepared for it: for by the same reason, we should not pray against any temptations." At the Savoy Conference, the Puritans again raised the old objection, and proposed to read, "from dying suddenly and unprepared." The Bishops replied, "From sudden death, is as good as from dying suddenly; which we therefore pray against, that we may not be unprepared." [Cardwell, Conferences, pp. 316. 352.] "A person," says Bishop Wilson, *Sacra Privata*, p. 358, "whose heart is devoted to God, will never be surprised by death."

Sedition] In 1544, from Primer of 1535. Hermann, "a seditione et similitate."

Privy conspiracy] In 1544. After this, in 1549 and 1552, came, "from the tyranny of the Bishop of Rome, and all his detestable enormities," which was omitted under Elizabeth; and Cosin, in his First Series of Notes, says that the Puritans (of James the First's time) wished to have it restored. It had been in the Primer of 1545, with "abominable" for "detestable."

Rebellion] Added, for obvious reasons, in 1661, by Cosin.

False doctrine, heresy] In 1544. Hermann, "ab omni errore."

Schism] In 1661. The Primer of 1535 had had "schismies."

Hardness of heart, and contempt, &c.] In 1544. Compare the Third Collect for Good Friday. See Prov. i. 25. The force of this deprecation is best seen by remembering that a final hardening of the heart is a penal infliction, provoked by habitual indifference to Divine love. We may well entreat our Lord to save us from repaying His love by coldness, lest the capacity of loving Him be justly taken away. We may well implore Him, also, to keep us from the terrible possibility of ignoring, and practically despising, His revelation and His commands. Com-

pare the beautiful Parisian Litany of the Holy Name of Jesus, "from neglect of Thy inspirations, Jesus, deliver us."

By the mystery] Here begin the Obscations, as they are called. They go on the principle that every several act of our Lord's Mediatorial life has its appropriate saving energy; that virtue goes out of each, because each is the act of a Divine Person, and has a Divine preciousness. When, therefore, we say, "Deliver us by Thy Nativity, by Thy Temptation," &c., we do not merely ask Him to remember those events of His human life, but we plead them before Him as mystically effective, as instinct with life-giving grace, as parts of a Mediatorial whole. Doubtless, the Death of our Lord is the meritorious cause of our salvation; we are redeemed by it, not by His Circumcision, or His Fasting; and to efface the distinction between it and all other parts of the "Economy," in regard to His office as the Lamb of God, would be an indication of theological unsoundness. At the same time it is also true that, in St. Leo's language, all our Lord's acts, as being related to His atoning Passion, are "sacramental," as well as "exemplary;" His Nativity is our spiritual birth, His Resurrection our revival, His Ascension our advancement. They are not only incentives and patterns, but efficient causes in the order of grace. So St. Bernard, in his second Pentecost Sermon, says that His Conception is to cleanse ours, His Resurrection to prepare ours, &c. More vividly, St. Anselm, in his fifteenth Prayer, "O most sweet Lord Jesus, by Thy holy Annunciation, Incarnation . . . Infancy, Youth, Baptism, Fasting . . . scourges, buffets, thorny crown," &c. But the deepest and tenderest expression of this principle (surpassing even Bishop Andrewes's obscations, "by Gethsemane, Gabbatha, Golgotha," &c.) is in the mediæval Golden Litany, printed by Maskell, *Mon. Rit.* ii. 244, "By Thy great meekness, that Thou wouldst be comforted by an angel, so comfort me in every time . . . For that piteous cry, in the which Thou commendedst Thy soul to Thy Father, our souls be commended to Thee," &c. The coarse and heartless fanaticism, which could cavil at these obscations as "a certain conjuring of God," was characteristic of John Knox and his friends. They so expressed themselves when criticizing the Litany ("certain suffrages devised of Pope Gregory"), in a letter to Calvin against the Prayer Book of 1552. Bishop Duppa writes, "No oath, nor no exorcism."

Of Thy holy Incarnation] So Sarum, York, Hereford, Roman, Cistercian, Dominican. "The mystery" is doubtless an allusion to 1 Tim. iii. 16. The thought which it suggests is that which of old made men bow down in adoration at the words in the Creed, "et Homo factus est." "By all the stupendous truths involved in Thine assumption of our humanity, wherein Thou, being true God, becamest true Man, combining two Natures in Thy single Divine Person, without confusion, and without severance; so that, in the Virgin's womb, Thou didst bring God and man together, undergoing all the conditions of infant life, Thyself unchangeably the Creator and Life-giver." The Roman adds, "By Thine Advent." Utrecht has "By Thine Annunciation, by Thine Advent and Nativity."

Thy holy Nativity] After Hereford. Sarum has only "Thy Nativity;" so Ordo Romanus. "Holy," however, is in the Sarum Primer [Maskell, ii. 102]. The Latin book of 1560

Luke ii. 7. 11. 21. Circumcision; by thy Baptism, Fast-
Matt. iii. 13—15. ing, and Temptation,
iv. 1, 2.
Ps. lxxix. 9. *Good Lord, deliver us.*

By thine Agony and bloody Sweat;
Luke xxii. 44. by thy Cross and Passion; by thy
Matt. xxvi. 28. precious Death and Burial; by thy
Phil. ii. 8. glorious Resurrection and Ascension;
1 Cor. xv. 3, 4. and by the coming of the Holy Ghost;
Eph. iv. 8. Acts ii. 1—4. 32.
33.
* Ps. xlv. 26. *Good Lord, deliver us.*

In all time of our tribulation; in all
John xvi. 33. time of our wealth; in the hour of
Prov. xxx. 8, 9. death, and in the day of judgment,
Ps. xxxi. 5. *Good Lord, deliver us.*
2 Tim. iv. 8. 1 Sam. xxvi. 24.

[Per sanctam Nativitatem tuam: [Hereford Use.]
Libera . . .]

Per sanctam Circumcisionem tuam: Salisbury Use.
Libera . . .

Per Baptismum tuum: Libera . . .

Per Jejunium tuum: Libera . . .

Per Crucem et Passionem tuam:
Libera . . .

Per pretiosam Mortem tuam: Li-
bera . . .

Per gloriosam Resurrectionem tuam:
Libera . . .

Per (admirabilem) Ascensionem
tuam: Libera . . .

Per adventum Sancti Spiritus (Para-
cliti): Libera . . .

In hora mortis: (Succurre nobis),
Domine.

In die judicii: Libera nos, Domine.

made "Nativity, Circumcision," &c., dependent on "mysterium." York has no mention of the Nativity.

Circumcision] Sarum has "holy Circumcision." It is not in the present Roman, but in two old Roman forms in Menard's notes to the Gregorian Sacramentary [741 and 923]. The Parisian of the Holy Name places after "Nativity," "Thine infancy, Thy most Divine life, Thy labours." Sarum Litany for the Dying adds "apparitionem tuam;" and Utrecht has, "circumcisionem et oblationem tuam."

Baptism, Fasting] Sarum, "by Thy Baptism, by Thy Fasting." Roman combines "Baptism and holy Fasting." Utrecht, "Baptism and Fasting." Sarum Primer, "Thy Baptism and much other penance doing."

Temptation] 1544. Primer of 1535, and Hermann, "temptations." Golden Litany, in Maskell, "The tempting of the fiend in the desert."

Agony and bloody Sweat] 1544. So Hermann. Golden Litany, "For that agony in which Thou offeredst Thee wilfully to death, obeying Thy Almighty Father; and Thy bloody sweat." Primer of 1535, "Thy painful agony, in sweating blood and water."

Cross and Passion] So Sarum, Roman, York for Easter Eve, and Anglo-Saxon (probably an old York form), in Procter, p. 231, and Hermann. Mabillon's Anglican, or Armorican, Hereford, Utrecht, Carthusian, Cistercian, Dominican, have "Passion and Cross;" so Sarum for the Dying. This is the more natural order. Sarum Primer, "Thy holy Passion." The Tours omits "Thy Cross," which forms the only obsecration in the Corbey MS. Litany [Menard, note 380], and in the Litany of the ninth century, in Muratori, i. 76. The Golden Litany dwells with intense tenderness on all the details of the Crucifixion, and on some points which are traditional or legendary. Parisian of the Holy Name, "Thine Agony and Passion, Thy Cross and forsaking.—*languores tuos.*"

Precious Death] Sarum. So in Sarum Litany for the Dying, "piissimam mortem tuam." Sarum Primer, "most piteous death." Ordo Romanus mentions the Cross, Passion, Death.

Burial] Not in Sarum; but in Sarum Primer, "Thy blessed burying." "Thy Death and Burial," in Roman, Utrecht, Strasburg, for Easter Eve, Primer of 1535, Hermann, Parisian.

Thy glorious Resurrection] So Sarum, Hereford, Narbonne, Moissac, Cistercian, Carthusian, Dominican, Sarum and Parisian Litanies for the Dying. Anglo-Saxon, York, Strasburg, Utrecht, Roman, and ordinary Parisian, "holy Resurrection."

Ascension] Anglo-Saxon, Sarum, York, Hereford, Roman,

Moissac, Narbonne, Cistercian, Carthusian, Dominican, Parisian, prefix "admirabilem" to "Ascensionem;" Strasburg and Utrecht have "glorious." Remiremont, "radiant." Golden Litany, "wonderful and glorious." Parisian of the Holy Name has, after "Ascension," "by Thy joys, by Thy glory."

The coming of the Holy Ghost] Sarum, for the Dying, "The coming of the Holy Ghost, the Paraclete;" so Ordo Romanus, present Roman, and Hermann. "The Paraclete" was omitted in 1544, as in Primer of 1535. Sarum, York, Hereford, Anglo-Saxon, Sarum Primer, Cistercian, Dominican, and Benedictine of M. Cassino, have "grace," instead of "coming." Armorican, "by the descent of the Holy Ghost." Tours and Utrecht simply, "by the Spirit, the Paraclete." Utrecht and others add an obsecration by the Second Advent, e. g. "by Thy future Advent," "by the majesty of Thine Advent."

In all time of our tribulation . . . wealth] 1544. After Primer of 1535, "in time of our tribulations, in the time of our felicity;" Hermann, "in all time," &c. The Scottish and American Books have "prosperity" for "wealth." The suffrage seems to refer not only to deliverance out of afflictions, but to deliverance from the special moral dangers which attend them. [Exod. vi. 9. Jer. v. 3. Hos. vii. 14. Amos iv. 6. See too the remarkable case of Ahaz, 2 Chron. xxviii. 22, and the awful picture in Rev. xvi. 11.] Suffering often hardens, instead of softening the heart; and therefore "not without reason has the Church taught all her faithful children to say, Suffer us not . . . for any pains of death to fall from Thee!" [Mill, Univ. Sermons, p. 332.] The trials of prosperity [Deut. viii. 14. Jer. v. 24; and Uzziah's case, 2 Chron. xxvi. 16, &c.] are more commonly recognized. Even the Greeks knew, as an ethical common-place, that it was hard to bear success without insolence and moral depravation. [Ar. Eth. iv. 8.] It is the Christian's wisdom and happiness to learn the secret of strength against both these forms of trial, as St. Paul learned it. [Phil. iv. 12.]

In the hour of death] So Sarum and Hereford, adding, as the response, "Succour us, O Lord." This suffrage, for which York substitutes "from the pains of hell," comes before the obsecrations in Benedictine of M. Cassino.

In the day of judgment] Sarum, York, Hereford, Roman, Ordo Romanus, Utrecht, Dominican, &c. The vernacular Litanies in Maskell have, "In the day of doom." Golden Litany, "Succour us, most sweet Jesu, in that fearful day of the strict judgment." Compare the *Dies Irae*. The following is a tabular view of the Deprecations and Obsecrations of the Sarum and Roman Litanies.

1 Kings viii. 30. We sinners do beseech thee to hear
Col. i. 18. us, O Lord God; and that it may
John x. 16. please thee to rule and govern thy holy
Ps. cvii. 7. Church universal in the right way;
We beseech thee to hear us, good Lord.

Jonah i. 14. That it may please thee to keep and
Prov. viii. 15. strengthen in the true worshipping of
Acts xiii. 22. thee, in righteousness and holiness of
2 Kings xviii. 5, 6. life, thy Servant *VICTORIA*, our
most gracious Queen and Governor;
We beseech thee to hear us, good Lord.

Ps. v. 1, 2. That it may please thee to rule her
Ps. xvii. 5. heart in thy faith, fear, and love, and that
lxxxvi. 11. she may evermore have affiance in thee,
Prov. xxi. 42. and ever seek thy honour and glory;
xxix. 25. *We beseech thee to hear us, good Lord.*

Ps. liv. 2. *We beseech thee to hear us, good Lord.*

Peccatores: Te rogamus, audi nos. Salisbury Use.
Ut [sanctam] Ecclesiam tuam [Ca- [York Use.]
tholicam] regere (et defensare) dig- [Salisbury Celebr.
neris: Te rogamus, audi nos. Ord.]

Ut Regi nostro et principibus nos- Salisbury Use.
tris pacem et veram concordiam atque
victoriam donare digneris: Te roga-
mus, audi nos.

<i>Sarum.</i>	<i>Roman.</i>
From all evil (also in York and Hereford).	From all evil.
From the snares of the devil (Y. H.).	From all sin.
From everlasting damnation (H.).	From Thy wrath.
From perils imminent for our sins.	From sudden and unforeseen death.
From assaults of demons.	From the snares of the devil.
From the spirit of fornication.	From the scourge of earthquake.
From the desire of vain-glory.	From anger and hatred, and all ill-will.
From all uncleanness of mind and body (Y. H.).	From the spirit of fornication.
From anger and hatred, and all ill-will (Y.).	From lightning and tempest.
From unclean thoughts.	From everlasting death.
From blindness of heart.	
From lightning and tempest.	
From sudden and unforeseen death (Y. sudden).	From pestilence, famine, and war.
By the mystery of Thy holy Incarnation (Y. H.).	By the mystery of Thy holy Incarnation.
By Thy Nativity (H. holy).	By Thine Advent.
By Thy holy Circumcision.	By Thy Nativity.
By Thy Baptism.	By Thy Baptism and holy Fast-ing.
By Thy Fasting.	
By Thy Cross and Passion (H. Passion and Cross).	By Thy Cross and Passion.
By Thy precious Death.	By Thy Death and Burial.
By Thy glorious Resurrection (H. Y. holy).	By Thy holy Resurrection.
By Thy wonderful Ascension (Y. H.).	By Thy wonderful Ascension.
By the grace of the Holy Ghost the Paraclete (Y. H.).	By the coming of the Holy Ghost the Paraclete.
In the hour of death, succour us, O Lord (H.).	
In the day of judgment, deliver us, O Lord (Y. H.).	In the day of judgment.

We sinners] Here begin the Petitions, or Supplications; introduced by a confession of our sinfulness. So in Sarum, York, Hereford, Roman, Cistercian, Carthusian, Dominican, &c., "We sinners beseech Thee to hear us." In some the suffrage is, "We sinners," and the response, "Beseech Thee, hear us." But the Dominican makes the reader say the whole, and the choir repeat the whole. As we have seen, the Sarum use was for the choir to repeat all after the reader, until after this petition. The

Litany of 1544, which joined this with the suffrage for the Church, added the word "God." And this may be set against the substitution of "Lord," for the original "our God," in "O Saviour of the world." Afterwards, in Sarum, Hereford, Dominican, come two suffrages, which remind us of the older "Pacifica," "That Thou wouldst give us peace . . . That Thy mercy and pity may preserve us." York places the first of these here, the second further on. The Roman has three suffrages, "That Thou spare us . . . That Thou forgive us . . . That it may please Thee to bring us to true repentance." Utrecht has two, for peace and pardon. Cistercian, for peace, only.

Thy holy Church universal] The Preces of Fulda pray for "deepest peace and tranquillity," and then for "the Holy Catholic Church, which is from one end of the earth to the other." Sarum simply, "Thy Church." So Hereford, Cistercian, Dominican. Procter's, York, and Roman, "Thy holy Church." Sarum at Ordination, "Thy Catholic Church." Sarum reads, "to govern and defend;" so Cistercian. Roman, "to govern and preserve." The Ordo Romanus, "to exalt Thy Church." The Primer of 1535, "to govern and lead Thy holy Catholic Church." The Book of 1559 has "universally." The Latin Book of 1560, "Catholicam." The Scottish Book, "Thy holy Catholic Church universally."

In the right way] This expresses generally, what in the Sarum had a special reference to the ecclesiastical state and religious orders,— "in holy religion . . . That it may please Thee to preserve the congregations of all holy persons in Thy service," or, as Hereford, in "Thy holy service."

That it may please Thee to keep . . .] To pray for the Sovereign before the Bishops was not absolutely a novelty at the time when our Litany was drawn up. The Sarum, indeed, before the separation from Rome, had prayed first for "Domnum Apostolicum" (the Pope), "and all degrees of the Church," then for "our Bishops and Abbats," then for "our King and Princes." York and Hereford had a like order (Hermann's Litany places "Sovereign" after "Clergy," and indeed after other classes). But the two vernacular Litanies printed by Maskell, place "our Kings," or "our King . . . and Princes," before "our Bishops." The York and Hereford read "our Kings." So the Dominican. The words "and strengthen . . . of life" were first added in the Queen's Chapel Litany of 1558. Prayers for the spiritual good of the Sovereign had not been usual in old Litanies; that of 1544 prayed that Queen Catherine might be kept in the Lord's fear and love, with increase of godliness, &c. The present Roman prays generally, that Christian kings and princes may have peace and true concord. The Ambrosian Preces for First Sunday in Lent have, "for Thy servants, the Emperor N., and the King N., our Duke, and all their army." Fulda, "for the most pious Emperor, and the whole Roman army."

May evermore have affiance] In 1549 and 1552 the reading

Ps. cxxi. 5.
cxxvii. 1. xxi.
7. 8. That it may please thee to be her
defender and keeper, giving her the
victory over all her enemies;

Ps. cii. 1. *We beseech thee to hear us, good Lord.*

Ezra vi. 10.
2 Sam. vii. 29.
1 Chron. xxix. 19. That it may please thee to bless and
preserve *Albert Edward* Prince of
Wales, the Princess of *Wales*, and all
the Royal Family;

Ps. lxi. 1. *We beseech thee to hear us, good Lord.*

Phil. i. 1.
Deut. xxxiii. 8.
(i. e. illumination
and perfection.)
John xvi. 13.
2 Tim. ii. 7. 15.
Matt. v. 14.
Tit. ii. 1. 7. 8. That it may please thee to illuminate
all Bishops, Priests, and Deacons, with
true knowledge and understanding of
thy Word; and that both by their
preaching and living they may set it
forth, and shew it accordingly;

Ps. lxxxiv. 8. *We beseech thee to hear us, good Lord.*

1 Tim. ii. 1, 2.
Prov. viii. 14—16.
xv. 22.
2 Chron. xix. 5, 6. That it may please thee to endure
the Lords of the Council, and all the
Nobility, with grace, wisdom, and
understanding;

We beseech thee to hear us, good Lord.

Deut. xvi. 18.
Ezra vii. 25, 26.
Rom. xiii. 3. That it may please thee to bless and
keep the Magistrates, giving them
grace to execute justice, and to main-
tain truth;

Ps. xvii. 6. *We beseech thee to hear us, good Lord.*

Ps. xxviii. 9.
John xvii. 11. That it may please thee to bless and
keep all thy people;

Ps. lxxxvi. 1. *We beseech thee to hear us, good Lord.*

Ps. xxix. 11.
Micah iv. 3, 4.
Ps. lxxii. 7—9. That it may please thee to give to
all nations unity, peace, and concord;

Ps. xvii. 1. *We beseech thee to hear us, good Lord.*

Ut Episcopos—nostros [et Prælatos [Hereford Use.]
nostros], in sancta religione [in tuo [Hereford Use.]
sancto servitio], conservare digneris:
Te rogamus, audi nos.

[. . . and for all the Lords of the [Liber Festivalis:
Council, and all other of the Nobilitie Bidding of
which dwell in the countrayes having Bedes.]
protection and government of the same,
that Almighty God may send grace so
to governe and ride the land . . .]

Ut cunctum populum Christianum
(pretioso sanguine tuo redemptum)
conservare digneris: Te rogamus . . .

[Ut pacem et concordiam nobis [York Use.]
dones.]

was "always." *Affiance*, in the sense of *trust*, is found in Shake-
speare. [2nd part of H. VI. iii. 1.]

Giving her the victory] So Sarum, York, Hereford, "peace,
and true concord, and victory." The thought probably came
from Psalm cxliv. 10. The Lyons has, "to preserve our King
. . . That Thou grant him life and victory." Hermann has a
suffrage, "to give to our Emperor perpetual victory against the
enemies of God" (i. e. the Turks): Luther's, "his enemies."

Royal Family] In our Mediæval Litanies, "our Princes" are
mentioned. In 1544, beside the suffrage for Queen Catherine,
there is one for "our noble Prince Edward, and all the King's
Majesty's children." The Primer of 1535 prayed for Queen
Anne, and the King's posterity. Under Edward and Elizabeth,
there was no suffrage of this kind. James I. inserted the present
suffrage, in this form, ". . . and preserve our gracious Queen Anne,
Prince Henry, and the rest of the King and Queen's royal issue."

Bishops, Priests, and Deacons] Sarum (after a suffrage for
the Pope, see above) prays for "our Bishops and Abbats." York,
"our Archbishop, and every congregation committed to him"
(as in the York form of our Collect for Clergy and People).
Hereford, "to preserve in Thy holy service our Bishop and our
Prelates" (which would include Abbats and Priors, Deans and
Archdeacons), "and us, the congregations committed to them."
Utrecht, "to preserve our Prelate in Thy holy service." Com-
pare the Lyons, "to preserve our Pontiff . . . That Thou wouldst
grant him life and health;" and it proceeds to pray for the
Clergy and People. So the Ambrosian Preces, "for all their
Clergy . . . and all Priests and Ministers;" and Fulda, "our
father the Bishop, all Bishops, Priests, and Deacons, and the

whole Clergy." The whole body of the Clergy were not defi-
nitely prayed for in our Church Litanies until 1544, when the
form ran, "Bishops, Pastors, and Ministers of Thy Church"
(after the pattern of the Primer of 1535), and so continued until
the last review, when the present form was adopted by way of
more expressly negating the ministerial claims of persons not in
Holy Orders. Hermann's has, "pastors and ministers," and
also, like the Primer of 1535, prays for the sending of "faithful
labourers into the harvest."

Lords of the Council . . . Nobility . . . Magistrates] 1544.
The Primer of 1535 has, "That our ministers and governors may
virtuously rule Thy people;" and Hermann's prays for "princi-
pem nostrum cum præsidibus suis," and for "magistratus."
Palmer compares an ancient Soissons formula, "Life and victory
to the Judges, and the whole army of the Franks." The Preces
of Fulda apparently refer to magistrates in the words, "For all
who are set in high place." Our present form certainly points to
the Tudor government by the Sovereign in his Privy Council.
"Truth" means the Faith held by the Church.

All Thy people] Sarum, York, Hereford, have "to preserve
the whole Christian people redeemed by Thy precious blood."
So a Litany of the ninth century in Murat. i. 77, Carthusian,
and Dominican. Tours is nearer to our form, "to preserve the
whole Christian people." The Corbey MS., "To remove Thy
wrath from the whole Christian people."

To give to all nations unity, peace, and concord] This comes
partly from the old suffrage, "peace and true concord to our
King and Princes," and partly from a shorter Sarum suffrage,
"That Thou wouldst give us peace;" or the York, "Give us

Deut. xxx. 6.
1 John v. 3.
Prov. viii. 13.
Deut. vi. 17.

That it may please thee to give us an heart to love and dread thee, and diligently to live after thy commandments;

Ps. cxliii. 1. *We beseech thee to hear us, good Lord.*

2 Cor. ix. 8.
Col. i. 9—11.
James i. 21.
Gal. v. 22, 23.
John xv. 2.

That it may please thee to give to all thy people increase of grace, to hear meekly thy Word, and to receive it with pure affection, and to bring forth the fruits of the Spirit;

Ps. cxix. 149. *We beseech thee to hear us, good Lord.*

Deut. xi. 16.
Matt. xxii. 29.
2 Tim. ii. 24—26.

That it may please thee to bring into the way of truth all such as have erred and are deceived;

Ps. xxx. 10. *We beseech thee to hear us, good Lord.*

Ps. cxxxviii. 3.
1 Cor. x. 12.
John xiv. 18.
Isa. xlii. 3.
Ps. cxlv. 14.
Rom. xvi. 20, viii. 37.

That it may please thee to strengthen such as do stand, and to comfort and help the weak-hearted, and to raise up them that fall, and finally to beat down Satan under our feet;

Ps. xlii. 1. *We beseech thee to hear us, good Lord.*

Heb. ii. 18.
Deut. iv. 39, 31.
Ps. lxxii. 12, lx. 11.
2 Cor. i. 3, 4, vii. 6.

That it may please thee to succour, help, and comfort, all that are in danger, necessity, and tribulation;

Ps. cxxx. 1, 2. *We beseech thee to hear us, good Lord.*

Ut miserias pauperum . . . relevare Salisbury Use.
digneris: Te rogamus, audi nos.

peace and concord." See above. Mabillon's Anglican or Armorican prays for peace and unity to be given to the whole Christian people; as the Roman does. In our present suffrage, "unity" may be understood in a religious or spiritual sense, while "peace" would mean freedom from external foes, and "concord," freedom from internal dissension.

To give us an heart to love, &c. 1544. Similar prayers exist in ancient Litanies; thus, the Corbey MS., "right faith, and a sure hope in Thy goodness, Lord Jesus." The Fleury, "to give us holy love . . . right faith . . . firm hope." So the Chigi MS., in three suffrages for faith, hope, and love. Parisian, for the same, in one suffrage. Compare also the Sarum, "That Thou wouldst make the obedience of our service reasonable . . . That Thou wouldst lift up our minds to heavenly desires." So the Dominican. The Sarum Primer, "ordain in Thy holy will our days and works." Roman has also, "to strengthen and keep us in Thy holy service." The Anglican or Armorican, "Grant us perseverance in good works . . . keep us in true faith and religion." "Dread," in the sense of holy and reverent fear; which can never be dispensed with by faithful worshippers of the God-Man, who will come to be their Judge. "If the Gospel be true, if this (Second) Psalm be true, we have great cause to fear Him" [Vaughan's "Lessons of Life and Godliness," p. 288]; but with "that one most holy and saving fear, the dread of His displeasure." [Arnold's "Christian Life," ii. 229.] Here again is a thought much needed in times when our Lord's Divine Majesty is often put out of sight.

To give to all Thy people increase of grace] A beautiful combination of the passage about the good ground in the Parable of the Sower, with James i. 21, and Gal. v. 22. Its date is 1544; but the Sarum Primer has something like it, "Vouchsafe to inform us with right-ruled understandings," from "Ut regularibus disciplinis nos instruere digneris," MS. Lit. of fifteenth century, Univ. Coll. The same form is in Cistercian and Dominican, and has a monastic import. And the Primer of 1535 has the first form of it, "To give the hearers of Thy word lively grace to understand it, and to work thereafter, by the virtue of the Holy Ghost." So Hermann, "To give the hearers increase of Thy

word, and the fruit of the Spirit." Litanies for the Sick have similar topics, "To pour into his heart the grace of the Holy Spirit . . . to bestow on him grace;" and the Ordo Romanus, Utrecht, Carthusian, and Eucharistic Litany in Chigi's MS., have, "to pour into our hearts." &c. An exquisite Litany in the Breviary of the Congregation of St. Maur prays, "That Thou wouldst write Thy law in our hearts . . . wouldst give Thy servants a teachable heart . . . that we may do Thy will with all our heart and mind . . . that we may gladly take on us Thy sweet yoke," &c.

To bring into the way of truth] In 1544. After 1535, "That all which do err and be deceived, may be reduced into the way of verity." Hermann, "errantes et seductos reducere in viam veritatis." The Church has always prayed for this. "Thou hearest God's Priest at the altar, exhorting God's people to pray for the unbelievers, that God would convert them to the faith." [St. Aug., Ep. 217.] Compare the old Gelasian intercession on Good Friday, for all heretics and all in error; the Mozarabic Preces for the same day, "May forgiveness set right those who err from the faith;" and, still more like our suffrage, the Lyons form, "That Thou wouldst bring back the erring into the way of salvation." Fuldan prays for preservation of the holiness and purity of the Catholic Faith.

To strengthen such as do stand] 1544. Hermann, "stantes confortare."

The weak-hearted] 1544. Primer of 1535 prays for those who are "weak in virtue, and soon overcome in temptation." Hermann, "pusillanimes et tentatos consolari et adjuvare."

That fall] 1544. Compare the old Gelasian prayer at Absolution of Penitents, "Succurre lapsis." Hermann, "lapsos erigere."

Beat down Satan] 1544. From Rom. xvi. 20; a text quoted in the Intercessory Prayer of St. Mark's Liturgy. Primer of 1535, "That we may the devil, with all his pomps, crush and tread under foot." Hermann, "Ut Satanam sub pedibus nostris conterere digneris." Strasburg, "That Thou wouldst grant us heavenly armour against the devil." Ratold's, Remiremont, Moiscac, for the Sick, "That Thou wouldst drive away from him all the princes of darkness."

Ps. cxxxi. 8.
cvii. 23, 26—28.
1 Tim. ii. 15.
James v. 14, 15.
Luke xviii. 15,
16.
Ps. lxxix. 11.

That it may please thee to preserve all that travel by land or by water, all women labouring of child, all sick persons and young children; and to shew thy pity upon all prisoners and captives;

Ps. xcl. 15.

Jer. xlix. 11.
1 Tim. v. 5.
Ps. xxv. 16, cxix.
134.

We beseech thee to hear us, good Lord.

Ps. cxlv. 19.

1 Tim. ii. 1, 3, 4.
Matt. v. 45.

That it may please thee to defend and provide for, the fatherless children, and widows, and all that are desolate and oppressed;

Ps. cxl. 6.

We beseech thee to hear us, good Lord.

Matt. v. 44.
Acts vii. 59, 60.
Prov. xvi. 7.

That it may please thee to have mercy upon all men;

We beseech thee to hear us, good Lord.

Ps. lv. 1.

That it may please thee to forgive our enemies, persecutors, and slanderers, and to turn their hearts;

Gen. i. 29.
Ps. lxxv. 9, civ.
13—15.
Matt. vi. 11.

We beseech thee to hear us, good Lord.

That it may please thee to give and preserve to our use the kindly fruits of

[. . for all parishions whereas they be on land or on water . . and for all women that are with child in this parish . . for all them that are sick . .]

[York Use:
Bidding of
Bedes, A.D.
1403.]

[Ut fratribus nostris et omnibus fidelibus infirmis sanitatem mentis et corporis donare digneris: Te rogamus, audi nos.]

[York Use.]

Ut miserias . . . captivorum in-
tueri et relevare digneris: Te rogamus,
audi nos.

Salisbury Use.

Ut fructus terræ dare et conservare
digneris: Te rogamus, audi nos.

To succour, help, and comfort] 1544. Primer of 1535 prays for "all extreme poverty," "Thy people in affliction or in peril, and danger by fire, water, or land." Hermann, "afflictos et periclitantes." Sarum and York have, "to look upon and relieve the miseries of the poor." So Dominican.

All that travel] 1544. Compare Hereford, "that Thou wouldest dispose the journey of Thy servants in salutis tue prosperitate" (as in the Collect, "Assist us mercifully," originally a prayer for one about to travel); and Dominican, "to bring to a harbour of safety all faithful persons, navigantes et itinerrantes." York has, "to give to our brethren and all faithful people who are sick, health of mind and body;" and Sarum and York add "captives" to "the poor," in the suffrage above cited. Compare the entreaty in Primer of 1535, "that teeming women may have joyful speed in their labour," and for "sick people." So Hermann, "for pregnant women, infants, and the sick, and captives." Compare also this and the preceding and following suffrages of our Litany, with intercessions in St. Chrysostom's Liturgy, "for the young, for those that travel by land or by water;" with St. Basil's, "Sail Thou with the voyagers, travel with the travellers, stand forth for the widows, shield the orphans, deliver the captives, heal the sick, remember all who are in affliction or necessity . . . be all things to all men;" with the Gelasian prayer on Good Friday, that God would "open prisons, loosen chains, grant a return to travellers, health to the sick, a safe harbour to those at sea;" and with the Ambrosian Preces for first Sunday in Lent, "for orphans, captives, . . . voyagers, travellers, those placed in prisons, in mines" (at forced labour there), "in exile." Probably, in these ancient intercessions, what was specially before the Church's mind was unjust and cruel imprisonment, so common in hard and lawless times, or under a Cæsarean despotism. To visit Christian prisoners was the delight of St. Leonard, the contemporary of Clovis I.; and St. Bathildis, Queen of Clovis II., "remembering her own bondage" (she had been a Saxon captive), "set apart vast sums for the redemption of captives." [Milman's Latin Christianity, ii. 221.]

The fatherless children, and widows] One of the tenderest petitions in the Prayer Book, and full of touching significance, as

offered to Him who entrusted His Mother to His Apostle. It was placed here in 1544 (the words being clearly suggested by such passages as Ps. cxlvi. 9; Jer. xlix. 11), but, like other passages of that date, is true to the old spirit of Church prayer. St. Mark's Liturgy prays for the widow and the orphan. Hermann, "ut pupillos et viduas protegere et providere digneris."

In "all that are desolate and oppressed," the Church seems to sweep the whole field of the sorrow which comes from "man's inhumanity to man," and which no civilization can abolish; and invokes for every such sufferer the help of Him whose sympathy is for all at once, and for each as if there were none beside. This indeed is one of the most stupendous results of the Incarnation, although perhaps but seldom faced in thought: that our Lord's sacred Heart is, so to speak, really accessible at once to all who need its inexhaustible compassion: He cares for each, not only as God, but as Man, with a special, personal, human tenderness, to which His Godhead gives a marvellous capacity of extension.

Mercy upon all men] This also is of 1544: the Primer of 1535 had expressed the same all-comprehending charity: "that unto all people Thou wilt show Thy inestimable mercy." The Church has ever prayed for all men. That her prayers do not avail for all, is not from any defect in her charity, or in the Divine benignity, but from the bar which a rebellious will can oppose to the powers of the kingdom of grace. Bp. Duppa's note is, "The objection against this is answered by what St. Paul saith, 1 Tim. ii. 4: the prayer being made in the same sense as God is said to will that all men should be saved."

Forgive our enemies] 1544: Primer of 1535, "forgive all warriors, persecutors, and oppressors of Thy people, and convert them to grace." Our present form (which is the same as Hermann's) is certainly preferable, and more like the Anglo-Saxon, "to bestow on our enemies peace and love." Compare St. Chrysostom's Liturgy: "for those who hate and persecute us for Thy Name's sake; for those who are without, and are wandering in error" (compare a previous suffrage), "that Thou wouldest convert them to what is good, and appease their wrath against us."

to give and preserve to our use the kindly fruits] "Kindly" of course means natural, produced after their kind. See Abp.

Ps. cxliii. 1. the earth, so as in due time we may enjoy them ;

We beseech thee to hear us, good Lord.

Acts v. 31.
2 Cor. vii. 10.
2 Chron. xxx. 18
—20.
Ps. xix. 12.
John vi. 63.
Jer. xxvi. 13.
James i. 23—25.

That it may please thee to give us true repentance ; to forgive us all our sins, negligences, and ignorances ; and to endue us with the grace of thy Holy Spirit to amend our lives according to thy holy Word ;

* Ps. xx. 7.

We beseech thee to hear us, good Lord.

John vi. 68, 69.
Heb. iv. 14—16.

Son of God : we beseech thee to hear us.

Son of God : we beseech thee to hear us.

John i. 29, 36.
Rev. vii. 14.

O Lamb of God : that takest away the sins of the world ;

John xvi. 33.

Grant us thy peace.

Acts xvii. 32.
Rev. v. 6.

O Lamb of God : that takest away the sins of the world ;

Luke xvii. 13.

Have mercy upon us.

[Sanguis tuus, Domine Jesu Christi, pro nobis effusa, sit mihi in remissionem omnium peccatorum, negligentiarum, et ignorantiarum mearum.]

["In elevatione corporis Christi." HORÆ B. V. M. A. D. 1530.]

Fili Dei : Te rogamus audi nos. Salisbury Use.

Agnus Dei, qui tollis peccata mundi : [Lyons.]
[dona nobis pacem.]

Agnus Dei, qui tollis peccata mundi : Salisbury Use.
miserere nobis.

Trench, English Past and Present, p. 167. So, "a kindly Scot" meant a native Scot ; and Ninian Wingate, an able opponent of Knox, calls Linlithgow his "kindly town," i. e. his native town. This suffrage may represent to us the oldest Western use of Litanies, to avert excessive droughts or rains, and to secure a good harvest. The substance of it is in Sarum, York, and Hereford, as in Anglo-Saxon, Lyons, Roman, Cistercian, Dominican. York adds, "Ut aeris temperiem bonam nobis dones." So Ordo Romanus and Utrecht. So Tours, "give us the fruit of the earth, . . . serenity of sky . . . good temperature of weather." So the Fleury: for "abundance of fruits, serenity of sky, seasonable rain." So in Ambrosian Preces: "Pro aeris temperie, ac fructu, et fecunditate terrarum, precamur te." The Sarum Primer asks for "wholesome and reasonable fir." Compare the anthems sung processionally in Sarum for fair or fair weather. "O Lord, King, God of Abraham, give us rain over the face of the earth, that this people may learn that Thou art the Lord our God, Alleluia. Is there any among the idols of the Gentiles that can give rain, but only Thou, O God? or can the heavens give rain except Thou wilt?" [Jer. xiv. 22.] "The waters are come in like a flood, O God, over our heads:" then Psalm lxix. 1.

So as in due time, &c.] Was added 1544. The whole suffrage was never more valuable than at a time like the present, when there is a tendency to substitute "laws of nature" for a Living God, and to ignore the fact that behind, above, beneath, around all "laws" is the absolute sovereign Personality of Him who "is ever present with His works, one by one, and confronts every thing which He has made by His particular and most loving Providence," at once the Lord of life and death, of health and sickness, of rain and drought, of plenty and famine. If men will not pray for seasonable weather, they cannot logically pray for recovery from sickness, for escape from shipwreck, or any temporal good whatever.

To give us true repentance, to forgive us] This suffrage, as it stands, was framed in 1544. Sarum, York, and Hereford have not this petition for repentance, but Roman has it, with prayers for pardon, before the suffrage for the Church: see above. York has, "That it may please Thee to give us remission of all our sins:" so the Ordo Romanus, which also asks for "spatium penitentiae;" and Sarum has, "to bring again upon us the eyes of Thy mercy." Carthusian, "spatium penitentiae et emendationem vite:" so the Chigi MS., "That Thou wouldst grant us a place of repentance;" and Utrecht asks for "compunction of heart and a fountain of tears;" so Tours; so Fleury, "To give us forgiveness of all our sins, Lord Jesus, we beseech Thee . . .

That Thou wouldst grant us *veram penitentiam agere.*" The ordinary Parisian has suffrages for true repentance, for remission of all sins, for compunction of heart and a fountain of tears. Litanies for the Sick have several suffrages of this kind. Ratold's MS. [in Menard, note 923], "That Thou wouldst grant him compunction of heart . . . a fountain of tears . . . space of repentance, if possible." Moiscac, "To bestow on him fruitful and saving repentance . . . a contrite and humbled heart . . . a fountain of tears." Salzburg, "compunction of heart . . . a fountain of tears." Narbonne, "That Thou wouldst give him remission of all sins." Remiremont, "pardon, remission, forgiveness of all his sins," &c. So in the Sarum Litany of Commendation of the Soul, and the Jumièges Litany: "Cuncta ejus peccata oblivioni perpetuæ tradere . . . remember not the sins and ignorances of his youth." This, from the Vulgate of our Psalm xxv. 7, has supplied our present "sins . . . and ignorances." "Negligentiam" occurs in the Vulgate of Num. v. 6. "Negligences" mean careless omissions (compare Hammond's prayer, "Lord, forgive my sins, especially my sins of omission"). "Ignorances," faults done in ignorance of our duty, such ignorance being itself a fault, because the result of carelessness.

Among the mediæval suffrages omitted in our present Litany are, "That Thou wouldst repay everlasting good to our benefactors—that Thou wouldst give eternal rest to all the faithful departed—that it may please Thee to visit and comfort this place:" and last of all the petitions came, "That it may please Thee to hear us;" as now in the Roman. This was omitted in 1544, as superfluous.

Son of God] The Sarum rule, in the procession after the Mass "for brethren and sisters," was that the choir should repeat in full "Son of God," &c., with the Agnus and the Kyrie. Tallis' Litany shows that this practice was continued by our Choirs.

O Lamb of God] The custom of saying Agnus Dei here is referred to in the Gelasian Rubric for Easter Eve. In Sarum, York, Hereford, as now in Roman and Parisian, Carthusian, Dominican, the Agnus is thrice said. The Sarum responses are, "Hear us, O Lord, Spare us, O Lord, Have mercy upon us:" the first and second of these are transposed in Roman and Parisian, as in York, Hereford, Dominican. The responses in Tours were, "Spare us, Give us pardon, Hear us." The Ordo Romanus has a twofold Agnus. Lyons a fourfold, with "Spare us, Deliver us, Grant us peace, Have mercy upon us:" so that our present form is just the second half of Lyons. The Agnus comes but once in the Cistercian. "Grant us peace" is the third response in Utrecht,

O Christ, hear us.
O Christ, hear us.

Ps. vi. 2, 4. Lord, have mercy upon us.
Lord, have mercy upon us.

Ps. cxxiii. 2, 3. Christ, have mercy upon us.
Christ, have mercy upon us.

Ps. lvii. 1.
 Luke xviii. 13. Lord, have mercy upon us.
Lord, have mercy upon us.

¶ Then shall the Priest, and the people with him, say the Lord's Prayer.

OUR Father, which art in heaven, Hallowed be thy Name. Thy kingdom come. Thy will be done in earth, As it is in heaven. Give us this day our daily bread. And forgive us our trespasses, As we forgive them that trespass against us. And lead us not into temptation; But deliver us from evil. Amen.

Priest.

Ps. ciii. 10. O Lord, deal not with us after our sins.

Answer.

Job xi. 6. Neither reward us after our iniquities.

1 John v. 14, 15.

Let us pray.

2 Chron. xxx. 9.
 2 Cor. i. 3.
 Ps. li. 17. xxxiv.
 18.
 Luke xi. 1.
 Rom. viii. 26.
 Ps. l. 15. * xxv.
 17.
 Luke xxii. 31, 32.
 Job i. 12, 13.
 Ps. xxxiii. 10.
 2 Kings xix. 20.
 32.
 Ps. cxviii. 6, 7.
 2 Cor. xii. 7-9.

O GOD, merciful Father, that despisest not the sighing of a contrite heart, nor the desire of such as be sorrowful; Mercifully assist our prayers that we make before thee in all our troubles and adversities, whenever they oppress us; and graciously hear us, that those evils which the

[Christe, audi nos.]

[Hereford Use.]

Kyrie eleison.

Salisbury Use.

Christe eleison.

Kyrie eleison.

PATER noster, qui es in cœlis; sanctificetur nomen tuum: adveniat regnum tuum: fiat voluntas tua, sicut in cœlo, et in terra. Panem nostrum quotidianum da nobis hodie: et dimitte nobis debita nostra, sicut et nos dimittimus debitoribus nostris: et ne nos inducas in temptationem: sed libera nos a malo. Amen.

Domine, non secundum peccata nostra facias nobis.

Neque secundum iniquitates nostras retribuas nobis.

DEUS, qui contritorum non despicias gemitum, et mœrentium non spernis affectum; adesto precibus nostris, quas pietati tuæ pro tribulatione nostra offerimus: implorantes ut nos clementer respicias, et solito pietatis tuæ intuitu tribuas, ut quicquid contra nos diabolicæ fraudes atque humanæ

Carthusian, Hermann. The Sarum Litany for the Dying had also, "Grant him peace" the ordinary Sarum Litany had a special suffrage for peace, and "grant us peace" was familiar as the response to the third Agnus said at Mass, immediately after the breaking of the Blessed Sacrament: the Primer of 1535 has, "Have mercy, Have mercy, Give us peace and rest." The great value of this supplication consists in its recognition of our Blessed Lord as the Victim that was once indeed slain, but is of perpetual efficacy. He took away our sins, in one sense, by His atoning Passion: and the Atonement can never be repeated. In another sense, He continually takes away our sins, by appearing for us as "the Lamb that was slain," presenting Himself as such to the Father, and pleading the virtue of His death. In this sense, as Bp. Phillpotts says [Pastoral of 1851, p. 54], "though once for all offered, that Sacrifice is ever living and continuous . . . To Him His Church . . . continually cries, Lamb of God . . . not, that *tookest* away, but still *takest*." With regard to the petition to the Prince of peace, who "is our Peace," for peace, compare the second Collect at Evensong. It is Christ's peace, not the world's: and this is brought out by the addition of "*thy*" in our form. Very touching are the entreaties in the Litany of the Abbey of St. Denis for St. Mark's day [Martene iv. 353], "O bestower of peace, vouchsafe us perpetual peace, Have mercy . . . O benignant Jesus, receive our souls in peace," &c.

O Christ, hear us] Hereford: so too in Sarum Primer, and Roman. The supplication also occurs in Mabillon's Caroline

Litany; after "Agnus . . . mundi, Christ hear us; three Kyries; Christ reigns, Christ commands, Christ conquers (thrice), Christ hear us." It also occurs in his Anglican, or Armoican. Lyons, Corbey, Tours, have it thrice, Strasburg once. The ordinary Ambrosian Litany has thrice, "O Christ, hear our voices:" then thrice, "Hear, O God, and have mercy upon us." Such "repetitions" are not "vain," unless those in Ps. cxxxvi. are so: and compare Matt. xxvi. 44.

Lord, have mercy] Sarum, York, &c. This is the only occasion on which, with us, the people repeat every one of the three sentences of the Kyrie after the Minister. Such was the old Sarum rule as to this Kyrie. [See also p. 22.]

Our Father] Here begins the Second Part of the Litany.

O Lord, deal not with us] In Sarum this verse and response, adapted from Psalm ciii. 10, were separated from the Lord's Prayer by "O Lord, show Thy mercy—And grant—Let Thy mercy come also upon us, O Lord, Even Thy salvation, according to Thy word: We have sinned with our fathers, We have done amiss and dealt wickedly." In York only this last verse and response intervene. In Roman, "O Lord, deal not," comes later. In the ordinary Parisian, it comes, as with us, immediately after the Lord's Prayer.

O God, merciful Father] This is very slightly altered from the Collect in the Sarum Mass "pro tribulatione cordis:" the Epistle being 2 Cor. i. 3-5, the Gospel, John xvi. 20-22. There is something pathetically significant in this adoption (1544) into

Ps. xxxv. 16.
lxxix. 14.
Heb. xiii. 15.

craft and subtilty of the devil or man worketh against us, be brought to nought; and by the providence of thy goodness they may be dispersed; that we thy servants, being hurt by no persecutions, may evermore give thanks unto thee in thy holy Church; through Jesus Christ our Lord.

Ps. xli. 5. cvi. 7.
8.

O Lord, arise, help us, and deliver us for thy Name's sake.

Ps. xlii. 1.
lxxviii. 2-4.
Joel i. 2, 3.

O GOD, we have heard with our ears, and our fathers have declared unto us, the noble works that thou didst in their days, and in the old time before them.

Nup. x. 35.
Rev. v. 13.

O Lord, arise, help us, and deliver us for thine honour.

1 John v. 7.

Glory be to the Father, and to the Son: and to the Holy Ghost;

Answer.

2 Pet. iii. 18.

As it was in the beginning, is now, and ever shall be: world without end. Amen.

Luke i. 68, 69.
74, 75.

From our enemies defend us, O Christ.

Isa. lxxiii. 9.

Graciously look upon our afflictions.

moliuntur adversitates ad nihilum redigas, et consilio misericordiæ tuæ allidas: quatenus nullis adversitatibus læsi, sed ab omni tribulatione et angustia liberati, gratias tibi in ecclesia tua referamus consolati. Per. Salisbury Use.

Exurge, Domine, adjuva nos, et libera nos propter nomen tuum.

DEUS, auribus nostris audivimus, patresque nostri annuntiaverunt nobis,

[Opus quod operatus es in diebus eorum, et in diebus antiquis.] [York Use.]

Exurge, Domine, adjuva nos, et libera nos propter nomen tuum. Salisbury Use.

Gloria Patri, et Filio, et Spiritui Sancto.

Sicut erat in principio, et nunc, et semper, et in sæcula sæculorum. Amen.

Ab inimicis nostris defende nos, Christe.

Afflictionem nostram benignus vide.

the ordinary Litany of a prayer composed for "cloudy and dark days." It may remind us of the selection of part of this same passage from 2 Cor. i., as the capitulum of the ordinary Sunday Vespers in Roman, and Saturday Vespers in Sarum. The lesson is obvious—that God is *always* needed as a Comforter. It may be added, that a somewhat different version of this Sarum prayer occurs in the Missal published in 1552 by Flaccus Illyricus, and supposed to represent the use of Salzburg in the tenth or eleventh century. By comparing our English with the Sarum form, it will be seen that we have added "merciful Father," "Thy servants," "evermore," and made a general reference to "all" troubles, "whosoever they oppress us:" omitting a reference to God's "accustomed" loving-kindness,—the clause, "but delivered from all tribulation and distress,"—and "being comforted" in the final clause. Hermann's and Luther's form is very like ours, but somewhat stronger, "in the afflictions which continually oppress us."

O Lord, arise] This, the last verse of our Psalm xlii., slightly altered, occurs, after several Preces, in the York Litany. It also occurs in the Sarum and York rites for Rogation Monday. In Sarum, the whole choir in their stalls repeated this "O Lord, arise," with Alleluia. Then was said, "O God, we have heard with our ears, our fathers have told us," that being the whole of the first verse of the Psalm according to the Vulgate: and then "immediately follows, Gloria." Then again, "O Lord, arise:" after which the procession set forth, the chanter commencing the Antiphon, "Arise, ye saints, from your abodes," &c. Another Antiphon began, "We and all the people will walk in the name of the Lord our God." In York the first "Exurge" was an anthem, "in eundo cantanda;" then came the first verse of the psalm, then a second "Exurge," after which the next words of the psalm were recited, "The work which Thou didst," &c., and so on through the whole psalm: "Exurge" being again said at the end. Among the processional Antiphons was, "Kyrie cleison, Thou who by Thy precious blood hast rescued the world from the jaws of the accursed serpent." It may be observed, that in

"Exurge" the "redime" of the Vulgate was altered into "libera:" and in the second repetition of "O Lord, arise," we have altered "name's sake" into "honour."

O God, we have heard] An appropriate representative of the Psalmody which followed the Litanies. [Jebb's Choral Service, p. 426.] In the ordinary Sarum Litany, as used out of Rogation-tide, there is no psalm: our Litany, as we have seen, here represents the old Rogation use. It also resembles the present Roman Litany, inasmuch as the latter has a psalm (our 70th) with a Gloria, after the Lord's Prayer: after the psalm come certain Preces, partly intercessory, then ten Collects, and a Conclusion. The ordinary Parisian has Preces before the psalm, and twelve collects after it. The order in Sarum, York, Hereford, is, Lord's Prayer, Preces, and Collects:—seven in Sarum, ten in York (the York Use has various minute resemblances to the Roman), and nine in Hereford. Among the York collects are ours for the first and fourth Sundays after Trinity,—the Collect for Clergy and People,—for Purity,—“O God, whose nature;” “Assist us;” “O God, from whom.” With respect to the forty-fourth Psalm, this fragment of it is specially apposite, as suggesting the true comfort amid despondency: compare Ps. lxxvii. 10. Isa. li. 9, &c. The history of God's past mercies is a fountain of hope for those who own Him as the Rock of ages, the "I Am" to all ages of His Church.

O Lord, arise] In this repetition we have a relic of the old use of Antiphons, to intensify the leading idea of the psalm as used at the time. See Neale's Commentary on the Psalms, p. 46.

Glory] This Gloria is an appendage to "O God, we have heard." Coming as it does amid supplications for help, it witnesses to the duty and the happiness of glorifying God at all times and under all circumstances. Compare the end of Psalm lxxxix. "Deo gratias" was in the fourth century a perpetual watchword; and the "Vere dignum" testifies to the duty of "giving thanks always." Compare Acts xvi. 25.

From our enemies] These preces, to the end of "Graciously

Ps. xxv. 16-18. Pitifully behold the sorrows of our hearts.

Heb. iv. 14. 1st. *Mercifully forgive the sins of thy people.*

Job xxxiii. 26. Favourably with mercy hear our prayers.
Ps. lxxix. 13.

Matt. ix. 27. *O Son of David, have mercy upon us.*

Heb. vii. 25. Both now and ever vouchsafe to hear us, O Christ.
xliii. 8.

John xiv. 13, 14. *Graciously hear us, O Christ; graciously hear us, O Lord Christ.*
1 John v. 14, 15.

Priest.

Ps. xxxiii. 10. O Lord, let thy mercy be shewed upon us;

Answer.

• Ps. xxxiii. 21. As we do put our trust in thee.

Let us pray.

Ps. cxix. 132. **W**E humbly beseech thee, O
Isa. liii. 45. Father, mercifully to look
Matt. viii. 17. upon our infirmities; and for the glory
Ps. lxxix. 9. of thy Name turn from us all those
Ezra ix. 13. evils that we most righteously have
Isa. xliii. 2, 3. of thy Name turn from us all those
Ps. xxxiii. 10. evils that we most righteously have
1 Cor. x. 13. deserved; and grant, that in all our
Matt. v. 8, 16. troubles we may put our whole trust
John xv. 8. and confidence in thy mercy, and ever-
1 Tim. ii. 5. more serve thee in holiness and pure-
1 John ii. 1, 2. ness of living, to thy honour and glory,
through our only Mediator and Advocate, Jesus Christ our Lord. *Amen.*

¶ *A Prayer of St. Chrysostom.*

ALmighty God, who hast given us grace at this time with one accord to make our common supplications unto thee; and dost promise, that when two or three are gathered together in thy Name thou wilt grant their requests; Fulfil now, O Lord, the desires and petitions of thy servants, as may be most expedient for them; granting us in this world knowledge of thy truth, and in the world to come life everlasting. *Amen.*

Dolorem cordis nostri respice ele- Salisbury Use.
mens.

Peccata populi tui pius indulge.

Orationes nostras pius exaudi.

Fili (Dei vivi), miserere nobis.

Hic et in perpetuum nos custodire digneris, Christe.

Exaudi nos, Christe; exaudi, exaudi nos, Christe.

Fiat misericordia tua, Domine, super nos.

Quemadmodum speravimus in te.

INFIRMITATEM nostram, quæsumus, Domine, propitius respice, et mala omnia quæ juste meremur (omnium Sanctorum tuorum intercessionibus) averte. Per.

hear us," were sung in procession, according to the use of Sarum, on St. Mark's day, "if it was necessary, in time of war." The choir repeated every verse. They were also in a Litany for the Dedication of a church, in the pontifical of St. Dunstan. But when they were adopted into the Litany of 1544, "Son of David" was made to represent "Fili Dei vivi." It has been conjectured, that this was owing to some misunderstanding of "Dei vivi," when written in a contracted form. In the St. Denis Litany [Martene iv. 353] we have a touching series of entreaties to Christ, "O good Jesu, protect us every where and always. Have mercy . . . O our Redeemer, let not Thy Redemption be lost in us. Have mercy . . . Lord God our King, pardon the guilt of us all. Have mercy," &c. [See Note in Appendix.] *

O Lord, let Thy mercy] This verse and response, Psalm xxxiii. 21, are part of the Sarum preces of Prime. In several editions of our Litany they were called *the Versicle and the Answer.*

We humbly beseech Thee] This is an enlarged and improved form of the Sarum Collect in the Memorial of All Saints (among the Memoræ Communes at the end of Lauds, feria 2). In 1544 it ran simply, "We humbly . . . and for the glory of Thy name sake, turn from us all those evils that we most righteously have deserved. Grant this, O Lord God, for our Mediator and Advocate, Jesu Christ's sake;" and was followed by four other collects and the Prayer of St. Chrysostom. In 1549 it took its present form, save that "name sake" was still read, and that "holiness" was not prefixed to "purity" until 1552.

2 Cor. xiii.

THE grace of our Lord Jesus Christ, and the love of God, and the fellowship of the Holy Ghost, be with us all evermore. *Amen.*

Here endeth the Litany.

PRAYERS AND THANKSGIVINGS

UPON SEVERAL OCCASIONS,

¶ *To be used before the two final Prayers of the Litany, or of Morning and Evening Prayer.*

PRAYERS.

¶ *For Rain.*

John xvi. 23.
Matt. vi. 31—33.
1 Kings viii. 35,
36.
Job v. 8—10.
Ps. lxxv. 9, 10.
civ. 13—15.
1 Cor. x. 31.

O GOD, heavenly Father, who by thy Son Jesus Christ hast promised to all them that seek thy Kingdom, and the righteousness thereof, all things necessary to their bodily sustenance; Send us, we beseech thee, in this our necessity, such moderate rain and showers, that we may receive the fruits of the earth to our comfort, and to thy honour; through Jesus Christ our Lord. *Amen.*

¶ *For fair Weather.*

Gen. vi. 5—7. 17.
vii. 17. 19. 23.
ix. 11. 15—17.
¶ Pet. iii. 20.
Isa. liv. 9.
Jer. v. 24, 25.
Hag. ii. 17—19.
Joël ii. 12—14.
Ps. cxlv. 15.
Isa. xxvi. 9.
xlix. 13.
Ps. cvii. 31.

O ALMIGHTY Lord God, who for the sin of man didst once drown all the world, except eight persons, and afterward of thy great mercy didst promise never to destroy it so again; We humbly beseech thee, that although we for our iniquities have worthily deserved a plague of rain and waters, yet upon our true repentance thou wilt send us such weather, as that we may receive the fruits of the

A Prayer of St. Chrysostom] This was added to the end of the Litany on its first introduction in its present form, in 1544.

The grace of our Lord] Was placed at the end of the Litany, after the Prayer of St. Chrysostom, in the Queen's Chapel Litany of 1558. [See note to it, p. 28.]

THE OCCASIONAL PRAYERS.

This collection of special prayers and thanksgivings was appended to Morning and Evening Prayer in 1661, but some of the prayers had been in use at an earlier date. Such a collection had occupied a place at the end of the ancient Service Books of the Church: and the use of prayers similar to these is very ancient.

In a printed Missal of 1514 (which formerly belonged to Bishop Cosin, and is now in his Library at Durham), there are *Missæ* and *Memoriæ Communes* (among others) with the following titles:—

<i>Missæ.</i>	<i>Memoriæ Communes.</i>
Missa pro serenitate aëris.	Contra aëreas tempestates.
— pluvia.	— invasores ecclesiæ.
— tempore belli.	— adversantes.
— contra mortalitatem hominum.	— paganos.
— pro peste animalium.	

But such occasional prayers were not uniformly the same in

the ancient Service Books; varying at different times according to the necessities of the period and of the locality.

In the first edition of the English Prayer Book, two occasional prayers, the one "for Rain," and the other "for Fair Weather," were inserted among the Collects at the end of the Communion Service. These were the same as those now placed here. Four more were added in 1552, the two "in time of Dearth," and those "in time of War," and of "Plague or Sickness;" and the whole six were then placed at the end of the Litany. Thanksgivings corresponding to these were added in 1604: and the remainder, both of the prayers and thanksgivings, were added in 1661, when all were placed where they now stand. These occasional Prayers and Thanksgivings are almost entirely original compositions, though they were evidently composed by divines who were familiar with expressions used for the same objects in the old Services. With several a special interest is connected, but others may be passed over without further notice. What few changes were made in this collection of occasional prayers are traceable to Bishop Cosin, except the important insertion of the Prayer for the Parliament, that for all Conditions of Men, and the General Thanksgiving. The rubric standing at the head of the prayers is Cosin's; but he would have explained "occasional" by adding "if the time require," at the end of it; which words were not printed. His revised Prayer Book also contains a rubrical heading in the margin, "*For the Parliament and Convocation during their sessions*," but no prayer is annexed. Probably the Commissioners concluded that as Convocation is part of Parlia-

earth in due season; and learn both by thy punishment to amend our lives, and for thy clemency to give thee praise and glory; through Jesus Christ our Lord. *Amen.*

¶ *In the time of Dearth and Famine.*

Matt. vii. 11.
Jer. v. 24.
Gen. i. 22.
Joel i. 16—20.
Ps. cvii. 17, 33,
34.
2 Chron. xx. 9.
Isa. xxx. 23, 24.
Rom. viii. 32.
Eph. iii. 20, 21.

O GOD, heavenly Father, whose gift it is, that the rain doth fall, the earth is fruitful, beasts increase, and fishes do multiply; Behold, we beseech thee, the afflictions of thy people; and grant that the scarcity and dearth (which we do now most justly suffer for our iniquity), may through thy goodness be mercifully turned into cheapness and plenty, for the love of Jesus Christ our Lord; to whom with thee and the Holy Ghost be all honour and glory, now and for ever. *Amen.*

¶ *Or this.*

2 Kings vi. 25.
2 Kings vii. 1, 16.
Ps. xxx. 10.
Jer. viii. 14.
Rom. xv. 4.
Ps. xlv. 1.
Zech. viii. 12.
Ps. cxlv. 15, 16,
19.
Prov. iii. 9.
James ii. 15, 16.
Deut. xvi. 14.

O GOD, merciful Father, who, in the time of Elisha the prophet, didst suddenly in Samaria turn great scarcity and dearth into plenty and cheapness; Have mercy upon us, that we, who are now for our sins punished with like adversity, may likewise find a seasonable relief: Increase the fruits of the earth by thy heavenly benediction; and grant that we, receiving thy bountiful liberality, may use the same to thy glory, the relief of those that are needy, and our own comfort, through Jesus Christ our Lord. *Amen.*

¶ *In the time of War and Tumults.*

2 Kings xix. 5.
Rev. xiv. 15.
Ps. xxii. 28.
2 Chron. xx. 4, 6.
Lam. iii. 39.
Ps. cxix. 137.
1 Sam. vii. 8,
xii. 10.
Ps. xviii. 27.
x. 17.
Job v. 12, 13.
Ps. xciv. 22.
xviii. 2, 35.

O ALMIGHTY God, King of all kings, and Governor of all things, whose power no creature is able to resist, to whom it belongeth justly to punish sinners, and to be merciful to them that truly repent; Save and deliver us, we humbly beseech thee, from

the hands of our enemies; abate their pride, assuage their malice, and confound their devices; that we, being armed with thy defence, may be preserved evermore from all perils, to glorify thee, who art the only giver of all victory; through the merits of thy only Son, Jesus Christ our Lord. *Amen.*

1 Chron. xxix. 11
Ps. xcvi. 1.

¶ *In the time of any common Plague or Sickness.*

O ALMIGHTY God, who in thy wrath didst send a plague upon thine own people in the wilderness for their obstinate rebellion against Moses and Aaron; and also, in the time of king David, didst slay with the plague of pestilence threescore and ten thousand, and yet remembering thy mercy didst save the rest; Have pity upon us miserable sinners, who now are visited with great sickness and mortality; that like as thou didst then accept of an atonement, and didst command the destroying Angel to cease from punishing, so it may now please thee to withdraw from us this plague and grievous sickness; through Jesus Christ our Lord. *Amen.*

Ps. cvi. 29.
Numb. xvi. 49.
xxv. 9.
2 Sam. xxiv. 15,
16.
1 Kings viii. 37—
39.
Hosea vi. 1.
Ps. lxxxix. 8.
xc. 7.
Numb. xvi. 47,
48.
2 Sam. xxiv. 17,
18, 25.
Ps. xxxix. 10, 12,
13.
Exod. xxxiii. 25.

¶ *In the Ember Weeks to be said every day, for those that are to be admitted into Holy Orders.*

A LMIGHTY God, our heavenly Father, who hast purchased to thyself an universal Church by the precious blood of thy dear Son; Mercifully look upon the same, and at this time so guide and govern the minds of thy servants the Bishops and Pastors of thy flock, that they may lay hands suddenly on no man, but faithfully and wisely make choice of fit persons to serve in the sacred Ministry of thy Church. And to those which

Eph. iv. 6.
2 Cor. v. 19.
Acts xx. 28.
Rev. vii. 9, 13, 14.
Ps. lxxxix. 14.
2 Tim. ii. 7.
Acts x. 2, 3,
1, 24, 25.
1 Tim. v. 22.
Acts vi. 5, 6.
Rom. x. 14, 15.
2 Cor. ii. 16, iii.
5, 6.
Eph. vi. 18—20.
1 Tim. iv. 12, 16.
2 Cor. v. 18—20.
1 Tim. ii. 3, 4.

ment by the constitution of the country, a separate prayer for the former was out of place.

§ *In the time of Dearth and Famine.*

The second of these prayers was—for what reason is not apparent—left out of the Prayer Book in several of the editions published during the reigns of Queen Elizabeth and James I. Bishop Cosin wrote it in the margin of his revised Prayer Book, and it was re-inserted in 1661, with some slight alterations of his making.

§ *In the time of any common Plague or Sickness.*

The collect form which is so strictly preserved in these prayers

was strengthened in this one by the addition of another Scriptural allusion in the invocation. This—from “didst send a plague” as far as “and also”—was inserted by Bishop Cosin, as were also the words relating to the atonement offered. The general tendency of such alterations by Bishop Cosin was to raise the objective tone of the prayers here and elsewhere; making our addresses to God of a more reverent and humble character.

§ *The Ember Collects.*

Every Day] The principle laid down in the rubric before the Collects, Epistles, and Gospels, applies to the use of these Collects. One of them ought, therefore, to be said at Evensong of the

shall be ordained to any holy function, give thy grace and heavenly benediction; that both by their life and doctrine they may set forth thy glory, and set forward the salvation of all men; through Jesus Christ our Lord.
Amen.

¶ *Or this.*

James i. 17.
Luke vi. 12, 13.
Eph. iv. 8, 11, 12.
1 Cor. xii. 8-10.
Heb. v. 4, 5.

ALMIGHTY God, the giver of all good gifts, who of thy divine providence hast appointed divers orders

in thy Church; Give thy grace, we humbly beseech thee, to all those who are to be called to any office and administration in the same; and so replenish them with the truth of thy doctrine, and endue them with innocency of life, that they may faithfully serve before thee, to the glory of thy great Name, and the benefit of thy holy Church, through Jesus Christ our Lord. *Amen.*

Deut. xxxiii. 8.
Mal. ii. 7.
John xiv. 16, 17.
26. xvii. 17.
1 Cor. iv. 1, 2.
Tit. ii. 7.
Eph. iv. 12-16.
v. 25-27.

¶ *A Prayer that may be said after any of the former.*

Exod. xxxiv. 6, 7.
2 Chron. xxxiv. 27.
Rom. vii. 23, 24.
2 Pet. ii. 19.
James v. 11.
1 Tim. ii. 3.
1 John ii. 1.

O GOD, whose nature and property is ever to have mercy and to forgive, receive our humble petitions; and though we be tied and bound with the chain of our sins, yet let the pitifulness of thy great mercy loose us, for, the honour of Jesus Christ, our Mediator and Advocate.
Amen.

DEUS, cui proprium est misereri semper et parcere, suscipe deprecationem nostram: ut quos delictorum catena constringit, miseratio tuæ pietatis absolvat. Per Christum Dominum nostrum.

Salisbury Use.
Greg. Sac.
Orationes pro peccatis.

Saturday before Ember Week, and at Mattins and Evensong every day afterwards until the Ordination Sunday. The Evensong previous to the latter should be included as being the eve of the Sunday itself.

The first of these Ember Collects is to be found in Bishop Cosin's Collection of Private Devotions, which was first published in 1627¹. It is also found*in the margin of the Durham Prayer Book, in his handwriting, with a slight alteration made by him at the end after it was written in. No trace of it has hitherto been discovered in any early collections of prayers or in the ancient Services, and therefore it may be concluded that it is an original composition of Bishop Cosin's, to whom we are thus indebted for one of the most beautiful and striking prayers in the Prayer Book, and one which is not surpassed by any thing in the ancient Sacramentaries or the Eastern Liturgies. The second Collect is taken from the Ordination Services, and is written into the margin of the Durham Prayer Book under the other in the handwriting of Sancroft, having been already inserted at the end of the Litany in the Prayer Book for the Church of Scotland, printed in 1637.

Under the old system of the Church there were special masses for the Wednesday, Friday, and Saturday, at all the four Ember Seasons; but the use of a special prayer every day during the Ember Weeks is peculiar to the modern Church of England. It may be added that the very pointed character of the words used is also modern, the older Ember-day Collects and Post-Com-munions making little direct reference to the ordainers or those to be ordained.

The Ember-day Collect is a continual witness before God and man of the interest which the whole body of the Church has in the ordination of the Clergy who are to minister in it. The entreaty of St. Paul, "Brethren, pray for us," is the entreaty that continually goes forth to the Church at large from its ministry; but never with greater necessity, or with greater force, than when the solemn act of Ordination is about to be performed by the Bishops, and a number of the future guides and leaders of

the Church are about to be empowered and authorized to undertake their office. This is, in fact, one of the most valuable of our Collects, wielding as it does the strong weapon of general prayer throughout the land on behalf of the Bishops, through whom all ministerial authority and power is conveyed from our Lord, and of the priests and deacons, to whom, from time to time, their ministry is delegated. A faithful reliance upon the promises of our Blessed Lord respecting prayer will give us an assurance that so general a supplication for a special object could not be without effect; and no age ever required that such a supplication should be offered more than the present, when the Clergy are growing more and more faithful, but when the necessities of some dioceses lead to a far too promiscuous admission of persons who are "fit," only by some stretch of language, "to serve in the sacred ministry of God's Church."

It is worth noticing that "the Bishops and Pastors of Thy flock" does not refer to the Bishops and the Priests who with them lay their hands on the heads of those who are ordained Priests. "Bishop and Pastor" is the expression used in all the documents connected with the election and confirmation of a Bishop; and no doubt it is here also used in the same sense, with reference to the Bishop as the earthly fountain of pastoral authority, ability [2 Cor. iii. 6], and responsibility.

The times for using one or other of these Collects are as follows:—

From Saturday Evensong before	{ 1st Sunday in Lent Whitsunday Sept. 18th Dec. 17th	to Saturday Evensong before	{ 2nd Sunday in Lent Trinity Sun- day Sept. 25th Dec. 24th	} inclusive.
-------------------------------------	---	-----------------------------------	--	--------------

§ *A Prayer that may be said, &c.*

This ancient prayer, which is one of the "Orationes pro Peccatis" in the Sacramentary of St. Gregory, comes into our Prayer Book through the Litany of the Salisbury Use, and is found in all the Primers of the English Church. It occupied its ancient place in the Litany of 1544, but was omitted from later Litanies until 1559. In 1661 it was transferred to this place. The most ancient English version of it known is that of the

¹ An earlier edition was privately printed, but this the writer has not seen.

¶ *A Prayer for the High Court of Parliament, to be read during their Session.*

1 Tim. ii. 1, 2.
Prov. xi. 14.
xxix. 2.
Deut. xvi. 18, 20.
1 Chron. xiii.
1-3.
1 Cor. x. 31.
Neh. ii. 20.
Prov. xx. 18.
xiv. 34.
Zech. viii. 16,
17, 19.
Ps. exxii. 6, 7.
Isa lxi. 8.
Ps. cxliv. 12-15.
Phil. iv. 6, 19.
Rom. ix. 5.

“Kingdoms” in
all Sealed
Books.

MOST gracious God, we humbly beseech thee, as for this Kingdom in general, so especially for the High Court of Parliament, under our most religious and gracious Queen at this time assembled: That thou wouldest be pleased to direct and prosper all their consultations to the advancement of thy glory, the good of thy Church, the safety, honour, and welfare of our Sovereign, and her Dominions; that all things may be so ordered and settled by their endeavours upon the best and surest foundations, that peace and happiness, truth and justice, religion and piety may be established among us for all generations. These and all other necessities for them, for us, and thy whole Church we humbly beg in the Name and mediation of Jesus Christ our most blessed Lord and Saviour.

Amen.

MOST gracious God, we humbly beseech thee, as for this Kingdom in general, so especially for the High Court of Parliament, under our most religious and gracious King at this time assembled: That thou wouldest be pleased to bless and direct all their consultations to the preservation of thy glory, the good of thy Church, the safety, honour, and welfare of our Sovereign, and his Kingdoms. Look, O Lord, upon the humility and devotion with which they are come into thy courts. And they are come into thy house in assured confidence upon the merits and mercies of Christ our blessed Saviour, that thou wilt not deny them the grace and favour which they beg of thee. Therefore, O Lord, bless them with all that wisdom, which thou knowest necessary to make the maturity of his Majesty's and their counsels, the happiness and blessing of this commonwealth. These and all other necessities for them, for us, and thy whole Church, we humbly beg in the Name and mediation of Christ Jesus our most blessed Lord and Saviour. *Amen.*

Form of Prayer
for the fast days
in 1625, 1643,
1644, and 1648.

fourteenth century, in Mr. Maskell's Prymer, which is as follows:—

“God, to whom it is propre to be merciful and to spare euermore, undirfonge” (undertake, “take,” in Hilsey's Prymer) “oure preieris; and the mercifulnesse of thi pitee asoile hem, that the chayne of trespas bindith. Bi crist oure Lord. So be it.”

The proper times for the use of this prayer are seasons of penitence. All days in Lent, Fridays, the Rogation Days, and the days of Ember Weeks, are obviously occasions when it comes in with a marked appropriateness; its use “after any of the former” clearly supposing that “the former” collects are accompanied by fasting and humiliation.

It may also be pointed out as a most suitable prayer for use by Clergy and Laity alike after any confession of sins in private prayer; or in praying with sick persons, in cases when an authoritative absolution is not to be used.

§ *The Prayer for the Parliament.*

There is every reason to think that this prayer, so consonant with the constitutional principles of modern times, was composed by Archbishop Laud, when Bishop of St. David's. The earliest form in which it is known is that above given, from a Fast-day Service printed in 1625¹. It also appears in at least two Forms of Prayer which were issued by Laud after he became Archbishop of Canterbury, and during the rule of that “Long” Parliament

by the influence of which he and the king suffered. It does not appear in a folio copy of “Prayers for the Parliament,” which is bound up at the beginning of Bishop Cosin's Durham Prayer Book, but it was inserted in a Fast-day Service for the 12th of June, 1661, and afterwards in its present place. The word “Dominions” was substituted for “Kingdoms” by an Order in Council of January 1st, 1801. As, however, the ancient style of our kings was “*Rex Angliæ, Dominus Hiberniæ,*” this seems to have been a constitutional mistake, as well as a questionable interference with the Prayer Book; but probably “dominions” was supposed to be the more comprehensive word, and one more suitable “kingdoms” to an empire so extended and of so mixed a character as that of the English Sovereigns.

The phrase “High Court of Parliament” in this prayer includes the House of Lords, the House of Commons, the Upper and Lower Houses of Convocation; which, together, are the three estates of the realm (by representation) assembled under the Sovereign. The petition referring to “the advancement of God's glory, and the good of His Church,” has a special reference to Convocation, which was no doubt evident enough at the time the prayer was composed, when Convocation was the primary assembly for the consideration of all religious questions having a national bearing.

This prayer may have been intended only for use before the several Houses of Parliament, when it was inserted here in 1661. Yet the remarks made on the Ember Collect apply to it in no small degree; and the general prayers of the Church may be expected to bring down a blessing upon the deliberations of the Parliament, in a higher degree than the local prayers daily used in each House.

¹ “A Forme of Common Prayer * * * to be read every Wednesday during the present visitation. Set forth by His Majestie's Authority. Reprinted at London by Bonham Norton and John Bill, Printers to the King's most excellent Majestie Anno 1625.”

¶ *A Collect or Prayer for all conditions of men, to be used at such times when the Litany is not appointed to be said.*

Act. xvii. 26.
Rev. iv. 11.
Job vii. 20.
1 Tim. ii. 1, 3, 4.
2 Cor. xxi. 4. lxxvii.
1, 2.
Luke ii. 30—32.
Gen. vi. 10.
Ps. cxxii. 6—8.
John xiv. 16, 17.
A. ts. xi. 26.
Col. i. 9—12.
Job. iv. 1—3.
1 Tim. ii. 11, 12.
Heb. xliii. 3.
1 Cor. xii. 5.
1 Cor. lxxix. 11.

O GOD, the Creator and Preserver of all mankind, we humbly beseech thee for all sorts and conditions of men; that thou wouldest be pleased to make thy ways known unto them, thy saving health unto all nations. More especially, we pray for the good estate of the Catholick Church; that it may be so guided and governed by thy good Spirit, that all who profess and call themselves Christians, may

be led into the way of truth, and hold the faith in unity of spirit, in the bond of peace, and in righteousness of life. Finally, we commend to thy fatherly goodness all those, who are any ways afflicted, or distressed, in mind, body, or estate; [** especially those for whom our prayers are desired,*] that it may please thee to comfort and relieve them, according to their several necessities, giving them patience under their sufferings, and a happy issue out of all their afflictions. And this we beg for Jesus Christ his sake. *Amen.*

** This to be said when any desire the Prayers of the Congregation.*

Ps. xciv. 19.
Isa. xliii. 3.
Phil. iv. 19.
Rom. v. 3.
xxxiv. 19.
John xvi. 24.

Corruption of the old genitive "Christes."

THANKSGIVINGS.

¶ *A General Thanksgiving.*

2 Cor. i. 3.
Gen. xxxii. 10.
Isa. lxxiii. 7.
Ps. cxlv. 7—9.
14. 21.

ALMIGHTY God, Father of all mercies, we thine unworthy servants do give thee most humble and

heartly thanks for all thy goodness and loving kindness to us, and to all men; [** particularly to those who desire now to offer up their praises and thanks-*

** This to be said when any that*

It may be mentioned that the expression "*most great, learned, and religious king,*" is contained in James the First's Act for a Thanksgiving on the Fifth of November.

§ *Prayer for all Conditions of Men.*

This prayer was composed by Dr. Peter Gunning, afterwards Bishop, successively, of Chichester and Ely, and one of the chief instruments, under God, in the restoration of the Prayer Book to national use in 1662. It has usually been supposed to be a condensed form of a longer prayer, in which he had endeavoured to satisfy the objections of the Puritans against the collect form of the Five Prayers, by amalgamating the substance of them into one. The first idea of it seems, however, to be taken from the nine ancient collects for Good Friday, of which we only retain three. Dr. Bisse states that when Gunning was Master of St. John's College, Cambridge, he would not allow this prayer to be used at Evensong, declaring that he had composed it only for Morning use, as a substitute for the Litany. And certainly, if it had been intended for constant use, it is strange that it was not placed before the Prayer of St. Chrysostom in Morning and Evening Prayer, but among the "Prayers for Several Occasions." The original intention must certainly have been to confine this general supplication to occasional use; and the meaning of "to be used" is probably identical with "that may be used." There are circumstances under which it may be desirable to shorten the service, and if the omission of this prayer can thus be considered as permissible, it will offer one means of doing so.

The prayer is cast in the mould of that for the Church in the Communion Service. Bishop Cosin altered the preface of that prayer to, "Let us pray for the good estate of Christ's Catholick Church," and the title of the prayer in the Rubric at the end of the Communion Service was altered by him in the same way. The title was often so printed in the last century, and had appeared in the same form in a book of Hours printed in 1531. See notes in Communion Service, pp. 175. 197.]

The tone and the language of the prayer very successfully imitate those of the ancient collects, and the condensation of its petitions shows how thoroughly and spiritually the author of it entered into the worth of that ancient mode of prayer, as distinguished from the verbose meditations which were substituted for it in the Occasional Services of James I. The petition, "That

all who profess and call themselves Christians, may be led into the way of truth," was evidently framed with reference to the Puritan Nonconformists, who had sprung up in such large numbers during the great Rebellion; but it is equally applicable as a prayer of charity for Dissenters at all times; and no words could be more gentle or loving than these, when connected with the petitions for unity, peace, and righteousness which follow. The concluding petitions have an analogy with the *Memoriae Communes* of the Salisbury Use, "*Pro quacunq[ue] tribulatione,*" and "*Pro infirmo.*" In another *Memoria*, that "*Pro amiso*" which comes between these two, the name of the person prayed for was mentioned, which may have suggested the parenthetical reference to individuals in this prayer.

There was, beside these Common Memorials, a Daily Prayer for the Sick in the Service at Prime, as follows:—

Omnipotens sempiterne Deus: Almighty and everlasting salus æterna credentium, exaudi God, the eternal salvation of nos pro famulis tuis pro quibus them that believe, hear us on misericordiæ tuæ, imploramus behalf of those thy servants of auxilium; ut reddita sibi sani- whom we beseech the help of tate, gratiarum tibi in ecclesia thy mercy; that health being tua referant actiones. Per restored unto them, they may Christum. Amen. [Gelas.] render thanks to thee in thy Church; through Jesus Christ our Lord. Amen.

It is a very excellent practice, when any are known to be dying, to commend them to the prayers of the Church (by name, or otherwise) before the Prayer for all Conditions of Men is said. It is equally applicable to cases of mental or bodily distress, as well as to its more familiar use in the case of sick persons; and the afflictions or distresses of "mind, body, or estate," which are so tersely but comprehensively named, show clearly that the special clause of intercession was not by any means intended to be limited to sickness.

THE OCCASIONAL THANKSGIVINGS.

These were all placed as they now stand in 1661; but they were, with two exceptions, printed at the end of the Litany (by

¹ Bishop Cosin provided a short service to be used in this place for any persons desiring the prayers of the Church. See the note at the end of the Visitation Office, p. 288.

have been
prayed for
desire to re-
turn praise.

Ps. cvii. 21, 22.
cxxxix. 14.
Rev. iv. 10, 11.
Ps. lxxi. 6. ciii.
2-5.
John iii. 16.
Rev. i. 5, 6.
Acts ii. 41, 42.
1 Pet. i. 3, 4.
Col. i. 3-5, 26, 27.
1 Sam. xii. 24.
Ps. xi. 5. ix. 1.
Matt. xii. 34, 35.
v. 16.
Rom. xii. 1.
Luke i. 74, 75.
Jude 26, 27.
Rom. xvi. 27.
al. *may* shew
forth, as in
Irish MS.

givings for thy late mercies vouchsafed unto them.] We bless thee for our creation, preservation, and all the blessings of this life; but above all, for thine inestimable love in the redemption of the world by our Lord Jesus Christ; for the means of grace, and for the hope of glory. And, we beseech thee, give us that due sense of all thy mercies, that our hearts may be unfeignedly thankful, and that we shew forth thy praise, not only with our lips, but in our lives; by giving up our selves to thy service, and by walking before thee in holiness and righteousness all our days; through Jesus Christ our Lord, to whom with thee and the Holy Ghost be all honour and glory, world without end. *Amen.*

¶ *For Rain.*

Ps. lxxv. 1. 9-13.
Hosea vi. 3.
Ps. cxlvii. 8, 9.
civ. 13-15.
Ps. lxxviii. 9.
Joel ii. 23, 24, 26.
Isa. xii. 1.
Gen. xxxii. 10.
Ps. cxlv. 9-11.
lxxii. 19.

O GOD our heavenly Father, who by thy gracious providence dost cause the former and the latter rain to descend upon the earth, that it may bring forth fruit for the use of man; We give thee humble thanks that it hath pleased thee, in our great necessity, to send us at the last a joyful rain upon thine inheritance, and to refresh it when it was dry, to the great comfort of us thy unworthy servants, and to the glory of thy holy Name; through thy mercies in Jesus Christ our Lord. *Amen.*

¶ *For fair weather.*

Isa. xxvi. 9.
Neh. ix. 33.
Acts xiv. 17.
Ps. cvii. 5, 6, 8.
cxxxviii. 2.
1 Chron. xvi. 28,
29. xxix. 13.
* Ps. lxxix. 14.

O LORD, God, who hast justly humbled us by thy late plague of immoderate rain and waters, and in thy mercy hast relieved and comforted our souls by this seasonable and blessed change of weather; We praise and

glorify thy holy Name for this thy mercy, and will always declare thy loving kindness from generation to generation; through Jesus Christ our Lord. *Amen.*

¶ *For Plenty.*

O MOST merciful Father, who of thy gracious goodness hast heard the devout prayers of thy Church, and turned our dearth and scarcity into cheapness and plenty; We give thee humble thanks for this thy special bounty; beseeching thee to continue thy loving kindness unto us, that our land may yield us her fruits of increase, to thy glory and our comfort; through Jesus Christ our Lord. *Amen.*

Jer. xxix. 11-14
Ps. cxvi. 5. cii.
17. lxxvi. 18-
20. cvii. 35-
38.
Deut. viii. 10.
Ps. xxxvi. 10.
lxxvii. 5, 6.
lxxxv. 12.
1 Thess. v. 18.

¶ *For peace and deliverance from our enemies.*

O ALMIGHTY God, who art a strong tower of defence unto thy servants against the face of their enemies; We yield thee praise and thanksgiving for our deliverance from those great and apparent dangers wherewith we were compassed: We acknowledge it thy goodness that we were not delivered over as a prey unto them; beseeching thee still to continue such thy mercies towards us, that all the world may know that thou art our Saviour and mighty Deliverer; through Jesus Christ our Lord. *Amen.*

Ps. lxi. 2, 3.
cxviii. 10-16.
xcviii. 1.
2 Chron. xx. 23-
30.
Ps. xviii. 6, 7, 48
-50. cxxiv. 1
-7. xxxvi. 10
Lam. iii. 22, 23.
1 Kings viii. 59,
60.
Ps. lxxiv. 9.

¶ *For restoring publick peace at home.*

O ETERNAL God, our heavenly Father, who alone makest men to be of one mind in a house, and stillest the outrage of a violent and unruly people; We bless thy holy Name, that it hath pleased thee to appease the seditious tumults which have been lately raised up amongst

* Ps. lxxviii. 6.
* lxxv. 7.
2 Sam. xxii. 44.
47, 49.
Ps. cxliv. 1, 2.
Prov. xxiv. 21, 22.
Ps. cxix. 27, 32.
35.
1 Tim. ii. 1, 2.
Rom. xiii. 1.
1 Pet. ii. 13-17.
Ps. cvii. 21, 22.
Heb. xiii. 15.

Royal authority only), after the Hampton Court Conference in 1606. The particular circumstances under which this liberty was taken with the Prayer Book by James I. are mentioned in the Historical Introduction. It is unnecessary to add any thing further here than that the Occasional Thanksgivings are now as entirely a part of the Prayer Book sanctioned by the Church as any other prayers.

§ *The General Thanksgiving.*

This was composed or compiled by Reynolds, Bishop of Norwich, for the revision of 1661. The first portion of it appears to be borrowed from the following opening of a Thanksgiving composed by Queen Elizabeth after one of her progresses, and which is printed (from a copy in the State Paper Office) in the

"Liturgies of Queen Elizabeth" of the Parker Society, p. 667, "I render unto Thee, O Merciful and Heavenly Father, most humble and hearty thanks for Thy manifold mercies so abundantly bestowed upon me, as well for my creation, preservation, regeneration, and all other Thy benefits and great mercies exhibited in Christ Jesus . . ." But it is possible that there is some older prayer, as yet unnoticed, which was the original of both Queen Elizabeth's and Bishop Reynolds'.

The remarks which have been made respecting the special clause in the "Prayer for all Conditions of Men," apply also to the special clause in the General Thanksgiving.

§ *For restoring publick peace at home.*

This is to be found in the margin of Cosin's Durham Prayer Book.

us; most humbly beseeching thee to grant to all of us grace, that we may henceforth obediently walk in thy holy commandments; and, leading a quiet and peaceable life in all godliness and honesty, may continually offer unto thee our sacrifice of praise and thanksgiving for these thy mercies towards us; through Jesus Christ our Lord. *Amen.*

¶ *For deliverance from the Plague, or other common sickness.*

1 Chron. xxi. 1-7.
Ps. lxxviii. 21.
xc. 7, 8.
Hab. iii. 2.
Ps. xxx. 3. cxvi.
7, 8. 12.
Rom. xii. 1.
Heb. xiii. 15.
Ps. lxxvi. 13, 14.
Heb. ii. 12.
Eph. iii. 21.

O LORD God, who hast wounded us for our sins, and consumed us for our transgressions, by thy late heavy and dreadful visitation; and now, in the midst of judgment remembering mercy, hast redeemed our souls from the jaws of death; We offer unto thy fatherly goodness our selves, our souls and bodies, which thou hast delivered, to be a living sacrifice unto thee, always praising and magnifying

thy mercies in the midst of thy Church; through Jesus Christ our Lord. *Amen.*

¶ *Or this.*

WE humbly acknowledge before thee, O most merciful Father, that all the punishments which are threatened in thy law might justly have fallen upon us, by reason of our manifold transgressions and hardness of heart; Yet seeing it hath pleased thee of thy tender mercy, upon our weak and unworthy humiliation, to assuage the contagious sickness wherewith we lately have been sore afflicted, and to restore the voice of joy and health into our dwellings; We offer unto thy Divine Majesty the sacrifice of praise and thanksgiving, lauding and magnifying thy glorious Name for such thy preservation and providence over us; through Jesus Christ our Lord. *Amen.*

Deut. xxviii. 15.
Ps. xc. 8.
Prov. xxviii. 14.
Lam. iii. 22.
Ps. cxlv. 9.
lxxix. 8.
1 Kings xxi. 29.
2 Chron. vii. 13, 14.
Ps. xxx. 2. 11, 12.
Ps. cxviii. 15.
Neh. ix. 5.
Isa. xxxviii. 18, 19.
Ps. lxxix. 30.
Luke i. 46, 47.
Heb. xiii. 15.
Gen. xvii. 1.
James iv. 6.
John iii. 19-21.
Rom. xiii. 12, 13.
2 Cor. vi. 2.
Matt. xxi. 5.
Phi. ii. 5-8.
Matt. xxv. 31, 32.
2 Tim. iv. 1.
1 Thess. iv. 16, 17.
Rev. i. 8. xix. 16.

in his handwriting; and is, no doubt, of his composition. There are two changes made in the course of writing it, with the evident object of moulding it in as charitable a form as possible. "Madness of a raging and unreasonable people" was one of the original phrases; and, "grant that we may henceforth live in peace and unity," was another; and both are altered in Cosin's own writing. This Thanksgiving offers another illustration of the restrained and temperate spirit in which the restoration of the Prayer Book and its revision were undertaken by men who

had suffered so much from the "outrage of a violent and unruly people," as Cosin and his coadjutors had suffered for many years.

Except the General Thanksgiving, none of these Occasional Thanksgivings are well adapted to the necessities of present times; and the introduction of several new "Memoriae Communes" would be a good work of revision, provided they were worded in language whose suitableness and dignity made them fit to be placed beside more ancient parts of the Prayer Book.

AN INTRODUCTION

TO THE

COLLECTS, EPISTLES, AND GOSPELS.

THE Liturgy consists of a fixed and unvarying portion, and of a portion which varies at least once a week; the fixed part is printed by itself in a later division of the Prayer Book, and the variable part is that included under the title of "The Collects, Epistles, and Gospels, to be used throughout the year," and now coming under notice.

In the early ages of the Church, the Office of the Holy Communion was contained in several separate volumes, one for the Epistles, called the Comes, Lectionarius, or Epistolarium; another for the Gospels, called the Evangelistarium; a third for the Anthems, called the Antiphonarius, or Gradual; and a fourth for the fixed part of the Service and the Collects, which went by the name of the Liber Sacramentorum, or Sacramentary. These four separate volumes were eventually united into one, under the name of the Missal; and the two portions of the Prayer Book in which the varying and unvarying parts of the Communion Service are contained, constitute, in fact, the Missal of the Church of England, which is almost universally bound in a separate form for use at the Altar.

The modern arrangement of these variable parts of the Liturgy is derived directly from the ancient Missals of the Church of England, of which the principal one was that of Salisbury. Like the rest of the Prayer Book, it has undergone some condensation. Offertory sentences were formerly placed in this part of the Liturgy, but are now collected into the unvarying portion. There was also a short Anthem, or Gradual (with its response), placed after every Epistle, and a Collect called "Post-communio," but both of these have been discontinued. The Introit, or Officium, was likewise appointed for every celebration of the Holy Communion, and a short Anthem to be sung during the Administration. In the first Prayer Book, the Introits were taken from the Psalms², and were all printed before the

Collect; but Hymns have been generally substituted since their omission. The "Communion" was also fixed in the first Prayer Book, being the Anthem, "O Lamb of God, which takest away the sins of the world, have mercy upon us;" and for this, a soft and solemn organ voluntary seems to have been afterwards substituted, such as is still to be heard at Durham Cathedral and elsewhere during the Administration.

This arrangement of the variable parts of the Communion Service is, however, much more ancient than the Salisbury Missal. The selection of the Epistles and Gospels for the Sundays and some of the other Holy Days is attributed to St. Jerome in the fourth century; and most of the Collects come to us originally from the Sacramentaries of St. Leo, Gelasius, and St. Gregory; the last of whom died A.D. 604.

§ Collects.

The Collects which are now used in the Communion Service appear to be the growth of the fifth and sixth centuries, as is stated above; though it is far from being improbable that the Sacramentaries of that date were, to a large extent, compilations of previously existing forms, rather than original compositions of those whose names they bear. These Sacramentaries have the appearance of methodizing and rearranging established customs and formularies; and there is an antecedent improbability in the statement that SS. Leo, Gregory, or any other single individual, invented so large a body of public devotions, and wrought so great a revolution in the habits of the Church, as to bring it suddenly into use. Cardinal Bona [Rer. Liturg., ii. 5; iv.] gives some evidence in support of the supposed Apostolic origin of the form of prayer known by the name of Collect, though he thinks the general tradition of the Christian world a sufficient proof that Gelasius and St. Gregory composed those now in use.

It may be considered an argument against this theory of Apostolic origin, that the Collect is a form of prayer unknown in the Eastern Church, which has always been so conservative with regard to its ancient customs and formularies. But Archdeacon Freeman has shown that there is a distinct likeness between certain kinds of hymns (called "Exapostellaria") of the Eastern Church, and the Collects of the Western, by which a common

¹ In the Prayer Book of 1549 a number of Sentences of Scripture were appointed for Post-Communions, and printed after the Agnus Dei.

² It may be useful to annex a list of the Introits, as arranged in the First English Prayer Book, as many Ritualists think them better adapted for their purpose than hymns:—

INTROITS.

<table border="0" style="width: 100%;"> <tr><td>1st Sunday in Advent</td><td>Ps. 1</td><td>Sunday next before Easter ...</td><td>Ps. 61</td></tr> <tr><td>2nd " "</td><td>120</td><td>Good Friday</td><td>22</td></tr> <tr><td>3rd " "</td><td>4</td><td>Easter Even</td><td>83</td></tr> <tr><td>4th " "</td><td>5</td><td>Easter Day, 1st Communion ..</td><td>16</td></tr> <tr><td>Christ. Day, 1st Communion ..</td><td>98</td><td> " 2nd "</td><td>3</td></tr> <tr><td> " 2nd "</td><td>8</td><td>Monday in Easter Week</td><td>62</td></tr> <tr><td>F. of St. Stephen</td><td>52</td><td>Tuesday "</td><td>113</td></tr> <tr><td> " St. John, Evangelist</td><td>11</td><td>1st Sunday after Easter</td><td>112</td></tr> <tr><td> " the Holy Innocents</td><td>79</td><td> " 2nd "</td><td>70</td></tr> <tr><td>Sunday after Christmas</td><td>121</td><td> " 3rd "</td><td>75</td></tr> <tr><td>Circumcision</td><td>122</td><td> " 4th "</td><td>82</td></tr> <tr><td>Epiphany</td><td>96</td><td> " 5th "</td><td>84</td></tr> <tr><td>1st Sunday after the Epiphany ..</td><td>13</td><td>Ascension Day</td><td>47</td></tr> <tr><td> " 2nd "</td><td>14</td><td>Sunday after Ascension Day ..</td><td>93</td></tr> <tr><td> " 3rd "</td><td>15</td><td>Whitsunday</td><td>88</td></tr> <tr><td> " 4th "</td><td>2</td><td>Monday in Whitsun Week</td><td>100</td></tr> <tr><td> " 5th "</td><td>20</td><td>Tuesday "</td><td>101</td></tr> <tr><td> " 6th "</td><td>20</td><td>Trinity Sunday</td><td>67</td></tr> <tr><td>Septuagesima</td><td>23</td><td>1st Sun. aft. } Ps. 119 { <i>Beati immacu-</i></td><td></td></tr> <tr><td>Sexagesima</td><td>24</td><td>Trinity ... } <i>culati.</i></td><td></td></tr> <tr><td>Quinquagesima</td><td>26</td><td> " 2nd "</td><td><i>In quo cor-</i></td></tr> <tr><td>Ash-Wednesday</td><td>6</td><td> " "</td><td><i>ripit?</i></td></tr> <tr><td>1st Sunday in Lent</td><td>32</td><td> " 3rd "</td><td><i>Retribue</i></td></tr> <tr><td> " 2nd "</td><td>130</td><td> " "</td><td><i>sero tuo.</i></td></tr> <tr><td> " 3rd "</td><td>43</td><td> " 4th "</td><td><i>Adhæsit pa-</i></td></tr> <tr><td> " 4th "</td><td>46</td><td> " "</td><td><i>vimento.</i></td></tr> <tr><td> " 5th "</td><td>54</td><td> " 5th "</td><td><i>Legem pone.</i></td></tr> </table>	1st Sunday in Advent	Ps. 1	Sunday next before Easter ...	Ps. 61	2nd " "	120	Good Friday	22	3rd " "	4	Easter Even	83	4th " "	5	Easter Day, 1st Communion ..	16	Christ. Day, 1st Communion ..	98	" 2nd "	3	" 2nd "	8	Monday in Easter Week	62	F. of St. Stephen	52	Tuesday "	113	" St. John, Evangelist	11	1st Sunday after Easter	112	" the Holy Innocents	79	" 2nd "	70	Sunday after Christmas	121	" 3rd "	75	Circumcision	122	" 4th "	82	Epiphany	96	" 5th "	84	1st Sunday after the Epiphany ..	13	Ascension Day	47	" 2nd "	14	Sunday after Ascension Day ..	93	" 3rd "	15	Whitsunday	88	" 4th "	2	Monday in Whitsun Week	100	" 5th "	20	Tuesday "	101	" 6th "	20	Trinity Sunday	67	Septuagesima	23	1st Sun. aft. } Ps. 119 { <i>Beati immacu-</i>		Sexagesima	24	Trinity ... } <i>culati.</i>		Quinquagesima	26	" 2nd "	<i>In quo cor-</i>	Ash-Wednesday	6	" "	<i>ripit?</i>	1st Sunday in Lent	32	" 3rd "	<i>Retribue</i>	" 2nd "	130	" "	<i>sero tuo.</i>	" 3rd "	43	" 4th "	<i>Adhæsit pa-</i>	" 4th "	46	" "	<i>vimento.</i>	" 5th "	54	" 5th "	<i>Legem pone.</i>	<table border="0" style="width: 100%;"> <tr> <td style="width: 15%;">6th Sun. aft. } Trinity ... }</td> <td style="width: 15%;">Ps. 119 ...</td> <td style="width: 15%;"><i>Et veniat.</i></td> <td style="width: 15%;"></td> <td style="width: 15%;"></td> <td style="width: 15%;"></td> </tr> <tr> <td>7th " "</td> <td>" "</td> <td><i>Memor esto.</i></td> <td>22nd " "</td> <td>" "</td> <td>{ <i>Principes</i></td> </tr> <tr> <td>8th " "</td> <td>" "</td> <td><i>Portio mea.</i></td> <td>" "</td> <td>" "</td> <td>{ <i>persecuti.</i></td> </tr> <tr> <td>9th " "</td> <td>" "</td> <td>{ <i>Bonitatem</i></td> <td>23rd " "</td> <td>" "</td> <td>{ <i>Appropin-</i></td> </tr> <tr> <td>10th " "</td> <td>" "</td> <td><i>fecisti.</i></td> <td>24th " "</td> <td>" "</td> <td><i>quet.</i></td> </tr> <tr> <td>11th " "</td> <td>" "</td> <td>{ <i>Manus tua.</i></td> <td>25th " "</td> <td>" "</td> <td>Ps. 124</td> </tr> <tr> <td>12th " "</td> <td>" "</td> <td><i>Defecit ani-</i></td> <td>St. Andrew, Apostle</td> <td>" "</td> <td>127</td> </tr> <tr> <td>13th " "</td> <td>" "</td> <td><i>ma.</i></td> <td>St. Thomas, Apostle</td> <td>" "</td> <td>129</td> </tr> <tr> <td>14th " "</td> <td>" "</td> <td>{ <i>In eter-</i></td> <td>Conversion of St. Paul</td> <td>" "</td> <td>128</td> </tr> <tr> <td>15th " "</td> <td>" "</td> <td><i>nun.</i></td> <td>Purification of St. Mary, Virg. ..</td> <td>" "</td> <td>138</td> </tr> <tr> <td>16th " "</td> <td>" "</td> <td>{ <i>Quomodo di-</i></td> <td>St. Matthias, Apostle</td> <td>" "</td> <td>134</td> </tr> <tr> <td>17th " "</td> <td>" "</td> <td><i>fest.</i></td> <td>Annunciation of the V. Mary ..</td> <td>" "</td> <td>140</td> </tr> <tr> <td>18th " "</td> <td>" "</td> <td>{ <i>Lucerna pe-</i></td> <td>St. Mark, Evang.</td> <td>" "</td> <td>131</td> </tr> <tr> <td>19th " "</td> <td>" "</td> <td><i>ditibus.</i></td> <td>St. Philip and St. James</td> <td>" "</td> <td>141</td> </tr> <tr> <td>20th " "</td> <td>" "</td> <td>{ <i>Iniquos</i></td> <td>St. Barnabas, Apostle</td> <td>" "</td> <td>133</td> </tr> <tr> <td></td> <td></td> <td><i>odio.</i></td> <td>St. John Baptist</td> <td>" "</td> <td>142</td> </tr> <tr> <td></td> <td></td> <td>{ <i>Feci judi-</i></td> <td>St. Peter, Apostle</td> <td>" "</td> <td>143</td> </tr> <tr> <td></td> <td></td> <td><i>cium.</i></td> <td>St. James, Apostle</td> <td>" "</td> <td>144</td> </tr> <tr> <td></td> <td></td> <td>{ <i>Mirabilia.</i></td> <td>St. Bartholomew, Apostle</td> <td>" "</td> <td>148</td> </tr> <tr> <td></td> <td></td> <td><i>Justus es.</i></td> <td>St. Matthew, Apostle</td> <td>" "</td> <td>115</td> </tr> <tr> <td></td> <td></td> <td>{ <i>Clamavi in</i></td> <td>St. Michael and all Angels</td> <td>" "</td> <td>117</td> </tr> <tr> <td></td> <td></td> <td><i>toto.</i></td> <td>St. Luke, Evangelist</td> <td>" "</td> <td>137</td> </tr> <tr> <td></td> <td></td> <td>{ <i>Vide humi-</i></td> <td>St. Simon and St. Jude, Apos. ..</td> <td>" "</td> <td>150</td> </tr> <tr> <td></td> <td></td> <td><i>lilitatem.</i></td> <td>All Saints</td> <td>" "</td> <td>149</td> </tr> </table>	6th Sun. aft. } Trinity ... }	Ps. 119 ...	<i>Et veniat.</i>				7th " "	" "	<i>Memor esto.</i>	22nd " "	" "	{ <i>Principes</i>	8th " "	" "	<i>Portio mea.</i>	" "	" "	{ <i>persecuti.</i>	9th " "	" "	{ <i>Bonitatem</i>	23rd " "	" "	{ <i>Appropin-</i>	10th " "	" "	<i>fecisti.</i>	24th " "	" "	<i>quet.</i>	11th " "	" "	{ <i>Manus tua.</i>	25th " "	" "	Ps. 124	12th " "	" "	<i>Defecit ani-</i>	St. Andrew, Apostle	" "	127	13th " "	" "	<i>ma.</i>	St. Thomas, Apostle	" "	129	14th " "	" "	{ <i>In eter-</i>	Conversion of St. Paul	" "	128	15th " "	" "	<i>nun.</i>	Purification of St. Mary, Virg. ..	" "	138	16th " "	" "	{ <i>Quomodo di-</i>	St. Matthias, Apostle	" "	134	17th " "	" "	<i>fest.</i>	Annunciation of the V. Mary ..	" "	140	18th " "	" "	{ <i>Lucerna pe-</i>	St. Mark, Evang.	" "	131	19th " "	" "	<i>ditibus.</i>	St. Philip and St. James	" "	141	20th " "	" "	{ <i>Iniquos</i>	St. Barnabas, Apostle	" "	133			<i>odio.</i>	St. John Baptist	" "	142			{ <i>Feci judi-</i>	St. Peter, Apostle	" "	143			<i>cium.</i>	St. James, Apostle	" "	144			{ <i>Mirabilia.</i>	St. Bartholomew, Apostle	" "	148			<i>Justus es.</i>	St. Matthew, Apostle	" "	115			{ <i>Clamavi in</i>	St. Michael and all Angels	" "	117			<i>toto.</i>	St. Luke, Evangelist	" "	137			{ <i>Vide humi-</i>	St. Simon and St. Jude, Apos. ..	" "	150			<i>lilitatem.</i>	All Saints	" "	149
1st Sunday in Advent	Ps. 1	Sunday next before Easter ...	Ps. 61																																																																																																																																																																																																																																																										
2nd " "	120	Good Friday	22																																																																																																																																																																																																																																																										
3rd " "	4	Easter Even	83																																																																																																																																																																																																																																																										
4th " "	5	Easter Day, 1st Communion ..	16																																																																																																																																																																																																																																																										
Christ. Day, 1st Communion ..	98	" 2nd "	3																																																																																																																																																																																																																																																										
" 2nd "	8	Monday in Easter Week	62																																																																																																																																																																																																																																																										
F. of St. Stephen	52	Tuesday "	113																																																																																																																																																																																																																																																										
" St. John, Evangelist	11	1st Sunday after Easter	112																																																																																																																																																																																																																																																										
" the Holy Innocents	79	" 2nd "	70																																																																																																																																																																																																																																																										
Sunday after Christmas	121	" 3rd "	75																																																																																																																																																																																																																																																										
Circumcision	122	" 4th "	82																																																																																																																																																																																																																																																										
Epiphany	96	" 5th "	84																																																																																																																																																																																																																																																										
1st Sunday after the Epiphany ..	13	Ascension Day	47																																																																																																																																																																																																																																																										
" 2nd "	14	Sunday after Ascension Day ..	93																																																																																																																																																																																																																																																										
" 3rd "	15	Whitsunday	88																																																																																																																																																																																																																																																										
" 4th "	2	Monday in Whitsun Week	100																																																																																																																																																																																																																																																										
" 5th "	20	Tuesday "	101																																																																																																																																																																																																																																																										
" 6th "	20	Trinity Sunday	67																																																																																																																																																																																																																																																										
Septuagesima	23	1st Sun. aft. } Ps. 119 { <i>Beati immacu-</i>																																																																																																																																																																																																																																																											
Sexagesima	24	Trinity ... } <i>culati.</i>																																																																																																																																																																																																																																																											
Quinquagesima	26	" 2nd "	<i>In quo cor-</i>																																																																																																																																																																																																																																																										
Ash-Wednesday	6	" "	<i>ripit?</i>																																																																																																																																																																																																																																																										
1st Sunday in Lent	32	" 3rd "	<i>Retribue</i>																																																																																																																																																																																																																																																										
" 2nd "	130	" "	<i>sero tuo.</i>																																																																																																																																																																																																																																																										
" 3rd "	43	" 4th "	<i>Adhæsit pa-</i>																																																																																																																																																																																																																																																										
" 4th "	46	" "	<i>vimento.</i>																																																																																																																																																																																																																																																										
" 5th "	54	" 5th "	<i>Legem pone.</i>																																																																																																																																																																																																																																																										
6th Sun. aft. } Trinity ... }	Ps. 119 ...	<i>Et veniat.</i>																																																																																																																																																																																																																																																											
7th " "	" "	<i>Memor esto.</i>	22nd " "	" "	{ <i>Principes</i>																																																																																																																																																																																																																																																								
8th " "	" "	<i>Portio mea.</i>	" "	" "	{ <i>persecuti.</i>																																																																																																																																																																																																																																																								
9th " "	" "	{ <i>Bonitatem</i>	23rd " "	" "	{ <i>Appropin-</i>																																																																																																																																																																																																																																																								
10th " "	" "	<i>fecisti.</i>	24th " "	" "	<i>quet.</i>																																																																																																																																																																																																																																																								
11th " "	" "	{ <i>Manus tua.</i>	25th " "	" "	Ps. 124																																																																																																																																																																																																																																																								
12th " "	" "	<i>Defecit ani-</i>	St. Andrew, Apostle	" "	127																																																																																																																																																																																																																																																								
13th " "	" "	<i>ma.</i>	St. Thomas, Apostle	" "	129																																																																																																																																																																																																																																																								
14th " "	" "	{ <i>In eter-</i>	Conversion of St. Paul	" "	128																																																																																																																																																																																																																																																								
15th " "	" "	<i>nun.</i>	Purification of St. Mary, Virg. ..	" "	138																																																																																																																																																																																																																																																								
16th " "	" "	{ <i>Quomodo di-</i>	St. Matthias, Apostle	" "	134																																																																																																																																																																																																																																																								
17th " "	" "	<i>fest.</i>	Annunciation of the V. Mary ..	" "	140																																																																																																																																																																																																																																																								
18th " "	" "	{ <i>Lucerna pe-</i>	St. Mark, Evang.	" "	131																																																																																																																																																																																																																																																								
19th " "	" "	<i>ditibus.</i>	St. Philip and St. James	" "	141																																																																																																																																																																																																																																																								
20th " "	" "	{ <i>Iniquos</i>	St. Barnabas, Apostle	" "	133																																																																																																																																																																																																																																																								
		<i>odio.</i>	St. John Baptist	" "	142																																																																																																																																																																																																																																																								
		{ <i>Feci judi-</i>	St. Peter, Apostle	" "	143																																																																																																																																																																																																																																																								
		<i>cium.</i>	St. James, Apostle	" "	144																																																																																																																																																																																																																																																								
		{ <i>Mirabilia.</i>	St. Bartholomew, Apostle	" "	148																																																																																																																																																																																																																																																								
		<i>Justus es.</i>	St. Matthew, Apostle	" "	115																																																																																																																																																																																																																																																								
		{ <i>Clamavi in</i>	St. Michael and all Angels	" "	117																																																																																																																																																																																																																																																								
		<i>toto.</i>	St. Luke, Evangelist	" "	137																																																																																																																																																																																																																																																								
		{ <i>Vide humi-</i>	St. Simon and St. Jude, Apos. ..	" "	150																																																																																																																																																																																																																																																								
		<i>lilitatem.</i>	All Saints	" "	149																																																																																																																																																																																																																																																								

origin seems to be indicated; and he gives the following hymns at Lauds on Easter Day as an example [Princip. of Div. Serv., i. 142]:—

“Thou, O Lord, that didst endure the cross, and didst abolish death, and didst rise again from the dead, give peace in our life, as only Almighty.”

“Thou, O Christ, Who didst raise man by Thy resurrection, vouchsafe that we may with pure hearts hymn and glorify Thee.”

Although the variable Exapostellaria in actual use are attributed to a ritualist of the tenth century, Archdeacon Freeman considers that they represent a much older system of precatory hymns, and quotes from Dr. Neale, that the aim of them “seems originally to have been a kind of invocation of the grace of God,” which is a special feature of Collects.

It is not quite correct, therefore, to say that such a form of prayer is wholly unknown in the Eastern Church; and this argument against the primitive antiquity of it cannot be considered to have much force.

There are two, and only two, prayers of the Church given in the New Testament. Both of these are in the Acts of the Apostles, and both of them have a striking similarity to the prayers we now know as Collects. The first is in Acts i. 24, 25, “Thou, Lord, which knowest the hearts of all men, show whether of these two Thou hast chosen, that he may take part of this ministry and apostleship, from which Judas by transgression fell, that he might go to his own place.” The second is in Acts iv. 24, “Lord, Thou art God, which hast made heaven, and earth, and the sea, and all that in them is: Who by the mouth of Thy servant David hast said, Why did the heathen rage, and the people imagine vain things? The kings of the earth stood up, and the rulers were gathered together against the Lord, and against His Christ. For of a truth against Thy holy Child Jesus, Whom Thou hast anointed, both Herod, and Pontius Pilate, with the Gentiles, and the people of Israel, were gathered together, for to do whatsoever Thy hand and counsel determined before to be done. And now, Lord, behold their threatenings: and grant unto Thy servants, that with all boldness they may speak Thy word, by stretching forth Thine hand to heal; and that signs and wonders may be done by the name of Thy holy Child Jesus.” In both of these prayers, the address, or invocation, is a prominent feature; and in the latter it occupies more than two-thirds of the whole prayer; while the actual supplication itself, though in both cases of the highest importance possible, is condensed into a few simple words. These Apostolic prayers, therefore, bear a great resemblance to Collects, and might not unreasonably be spoken of as the earliest on record.

But the real model of this form of prayer is to be found in a still higher quarter, the Lord's Prayer itself. If we compare some of the best of our ancient or modern collects (as, for instance, the Collect for Whitsunday, which has been familiarly known to the Church in her daily Service for at least twelve centuries and a half, or that for the Sunday after Ascension, which is partly of Reformation date) with the Prayer of Prayers, we shall find in both that the tone is chiefly that of adoration, and subordinately that of supplication; and, also, that the human prayer follows the Divine pattern in the adoption of a condensed form of expression, which is in strict accordance with the injunction, “God is in heaven, and thou upon earth, therefore let thy words be few.” Such a comparison will bring home a conviction to the mind, that when we use this terse form of mixed adoration and prayer, we are not far from carrying out, with literal exactness, the still more authoritative injunction of Him who gave us His own prayer as the type of all others, “After this manner, therefore, pray ye.”

The origin of the name “Collect” is uncertain; and various meanings have been given to it. Some ritualists have connected

¹ It is an ancient rule of the Church to have an *unseven* number of Collects. Micrologus [iv.] says that either one, three, five, or seven are used: one from tradition; three, because our Lord prayed thrice in His agony; five, because of His fivefold Passion; seven, because there are seven petitions in the Lord's Prayer.

it with the collected assembly² of the people; others have interpreted the name as indicating that the prayer so called collects together the topics of previous prayers, or else those of the Epistle and Gospel for the day. But the most reasonable interpretation seems to be that which distinguishes the Collect as the prayer offered by the priest alone on behalf of the people, while in Litanies and Versicles, the priest and the people pray alternately. This interpretation is found in Bona, Rer. Liturg., ii. 5. iii., Durand. iii. 13, and Micrologus, iii.; the words of the latter being, “Oratio quam Collectam dicunt, eo quod sacerdos, qui legatione fungitur pro populo ad Dominum omnium petitiones ea oratione colligit atque concludit.” As of Common Prayer, in general, so we may conclude especially of the Collect, in particular, that it is the supplication of many gathered into one by the voice of the priest, and offered up by him to the Father, through our Lord and only Mediator³.

There is a very exact and definite character in the structure of Collects; so exact, that certain rules have been deduced from these prayers of the Saints for the construction of others, as rules of grammar are deduced from classic writers.

First, may be mentioned the characteristics which distinguish this special form of prayer, and which have been loosely mentioned above:—

1. A Collect consists of a single period, seldom a long one.
2. A single petition only is offered in it.
3. Mention is made of our Lord's Mediation; or else
4. It ends with an ascription of praise to God.

These features of the Collect at once distinguish it from the long and often involved forms of Eastern prayers, and also from the precatory meditations which became so familiar to English people in the seventeenth century; and the chastened yet comprehensive character of Collects is owing, in no small degree, to the necessities imposed upon the writers of them by this structure.

This general outline of the Collect develops itself in detail on a plan of which the most perfect form may be represented by two of our finest specimens, the one as old as the Sacramentary of St. Gregory, in the sixth century, the other composed by Bishop Cosin, more than a thousand years later.

	Whitsunday.	6th Sunday after Epiphany.
1. Invocation.	GOD,	O GOD,
2. Reason on which the Petition is to be founded.	Who as at this time didst teach the hearts of Thy faithful people by sending to them the light of Thy Holy Spirit;	Whose blessed Son was manifested that He might destroy the works of the devil, and make us the sons of God, and heirs of eternal life;
3. PETITION.	grant us by the same Spirit to have a right judgment in all things,	grant us, we beseech Thee, that having this hope, we may purify ourselves, even as He is pure;
4. Benefit hoped for.	and evermore to rejoice in His holy comfort;	that when He shall appear again with power and great glory, we may be made like unto Him in His eternal and glorious Kingdom,
5. Mention of Christ's Mediation, or Ascription of praise: or both.	through the merits of Christ Jesus our Saviour, Who liveth and reigneth with Thee, in the unity of the same Spirit, one God, world without end.	where with Thee, O Father, and Thee, O Holy Ghost, He liveth and reigneth, ever one God, world without end.

Thus it will be observed that, “after the Invocation, a foundation is laid for the petition by the recital of some doctrine, or of

² The Holy Communion was once known by the name Collecta. Bona, I. 3. ii.

³ So in the old “Mirroure,” or commentary on the Divine Offices, the explanation of the word is given thus: “Yt is as moche as to saye a gatherynge together, for before thys prayer ye dresse you to god, and gather you in oned to pray in the person of holy chyrche, that ye shoulde be the soner harde.” And with respect to the ending the explanation is very properly given: “Ye ende all youre orysones by oure lorde Jesu cryste, and in hys byssed name, by cause he sayde in his gospel, that what euer ye aske the father in my name, he shall gyue yt you.” fol. lxxiii.

some fact of Gospel history, which is to be commemorated. Upon this foundation so laid down, rises the petition or body of the prayer. Then, in a perfect specimen . . . the petition has the wings of a holy aspiration given to it, whereupon it may soar to heaven. Then follows the conclusion, which, in the case of prayers not addressed to the Mediator, is always through the Mediator, and which sometimes involves a Doxology, or ascription of praise¹. This last member of the Collect has, indeed, always been constructed with great care, and according to rules which were put into the form of memorial verses, at a period when it was the custom to write the Collect in a short form, and only to indicate the ending by "per," "Qui vivis," "per eundem," or whatever else were its first word or words. One of these aids to memory is as follows:—

"Per Domipum, dicas si Patrem Presbyter oras.
Si Christum memores 'per Eundem,' dicere debes.
Si loqueris Christo 'Qui vivis,' scire memento;
'Qui Tecum,' si sit collectæ finis in Ipso;
Si memores Flamen; 'Ejusdem,' dic prope finem²."

Illustrations of these endings will be found in the Collects for the Epiphany, the Nativity, Easter Day, and Whitsunday.

The number of the variable Collects in the Book of Common Prayer is eighty-three. These are all traced to their original sources, so far as they have been discovered, in the following pages; and it will be observed, that fifty-nine out of the eighty-three have come to us through the Sarum Missal, from the ancient Sacramentaries; all but one of that number being contained in the Sacramentary of St. Gregory. Of the remaining twenty-four, the germ and spirit, and often the language, may be found in ancient Liturgical forms; and the sixteen of the twenty-four, of which no such origin is indicated in the following pages, will perhaps be discovered, by future research, to be either translations or adaptations. Only one new Collect, that for St. Andrew's Day, was inserted in 1552; and only four in 1661. The latter are written in the margin of Bishop Cosin's Durham Book, in his handwriting. That for St. Stephen's Day he adapted from one (in the Scottish Prayer Book) which is attributed to Archbishop Laud, while those for the Third Sunday in Advent, the Sixth Sunday after Epiphany, and Easter Even, are either composed by himself, or derived from some ancient originals which have not been identified.

The primary use of the Collect is to give a distinctive tone to the Eucharistic Service, striking the key-note of prayer for the particular occasion on which the Sacrifice is offered. But by the constant use of it in its appointed place in the Daily Matins and Evensong, it also extends this Eucharistic speciality into the other public Services of the Church, and carries it forward from one celebration to another, linking these offices on to the chief Service and Offering which the Church has to render to Almighty God. "Used after such celebration, the Collect is endued with a wonderful power for carrying on through the week the peculiar Eucharistic memories and work of the preceding Sunday, or of a Festival. Under whatsoever engaging or aweing aspect our Lord has more especially come to us then in virtue of the appointed Scriptures, the gracious and healthful visitation lives on in memory, nay, is prolonged in fact. Or in whatever special respect, again, suggested by these same Scriptures, and embodied for us in the Collect, we have desired to present ourselves 'a

¹ Goulburn on the Communion Office, p. 37.

² A much longer form may be found at p. 73 of Chambers' Sarum Psalter, with an elaborate note on the subject. The following rules may prove sufficient for practical purposes at the present day:—

1) Collects addressed to God the Father should end:—"Through Jesus Christ our Lord [or if our Lord has been previously mentioned:—"Through the same Jesus Christ our Lord"], Who liveth and reigneth with Thee and the [or if the Holy Ghost has been previously mentioned:—"The same"] Holy Ghost, one God, world without end. Amen."

2) Collects addressed to God the Son should end:—"Who liveth and reigneth with the Father and the [or 'the same'] Holy Ghost, one God, world without end. Amen."

3) Collects addressed to the Blessed Trinity should end:—"Who liveth and reigneth, one God, world without end. Amen."

Some other variations, as "Where with Thee," after the mention of Heaven, will suggest themselves.

holy and lively sacrifice' in that high ordinance, the same oblation of ourselves do we carry on and perpetuate by it. Through the Collect, in a word, we lay continually upon the altar our present sacrifice and service, and receive, in a manner, from the altar, a continuation of the heavenly gift³." Thus it is a constant memorial before God of the great Memorial which joins on the work of the Church on earth to the intercession of our Mediator in heaven; and it is also a memorial to the mind of every worshipper of the sanctification which is brought upon all our days and all our prayers by the Sacramental Presence of our Blessed Lord. [See also p. 24.]

§ The Epistles and Gospels.

The Holy Communion was celebrated and received by the faithful for nearly twenty years before St. Paul wrote his first Epistle, and for nearly thirty years before the first Gospel was written by St. Matthew; and none of the Gospels or Epistles are likely to have been generally known in the Church until even a much later time. The Scriptures of the New Testament did not, therefore, form any part of the original Liturgies⁴. It has been supposed by many ritualists, that portions of the Old Testament were read at the time of the celebration: and the gradual introduction of our present system is indicated by the usage shown in an Irish Communion Book of the sixth century, which has one unvarying Epistle and Gospel, 1 Cor. xi., and St. John vi. This system is attributed to St. Jerome by the almost unanimous voice of ancient writers on the Divine Service of the Church; and a very ancient Book of Epistles and Gospels exists, called the Comes, which has gone by the name of St. Jerome at least since the time of Amalarius and Micrologus, in the ninth and eleventh centuries.

The antiquity of the Comes Hieronymi has been disputed, chiefly because the system of Epistles and Gospels which it contains differs from that of the Roman rite; but there seem to be several good reasons for supposing that it really belongs to as early a time as that of St. Jerome; and as its system agrees with the old and modern English one, where it differs from the Roman, the question has a special interest in connexion with the Book of Common Prayer.

This ancient Lectionary, or Comes, was published by Pamelius in the second volume of his *Liturgicon Ecclesiæ Latinæ*, under the title, *Divi Hieronymi presbyteri Comes sive Lectionarius*: and is also to be found in the eleventh volume of St. Jerome's Works, p. 526. It contains Epistles and Gospels for all the Sundays of the year, the Festivals of our Lord, some other Festivals, and many Ferial days. It is some evidence in favour of its great antiquity that no saints are commemorated in it of a later date than the time of St. Jerome: and that the Epiphany is called by the name of the Theophania, a name which was discontinued not long after in the Western Church. The Comes is mentioned in the Charta Cornutiana, a foundation deed belonging to a Church in France, and printed by Mabillon [*Lit. Gall. Pref. vii.*], and this charter is as early as A.D. 471. It is mentioned by Amalarius [iii. 40], who wrote A.D. 820; and in Micrologus [xxv.], a liturgical treatise of about A.D. 1080, it is spoken of as "*Liber Comitatus sive Lectionarius, quem Sanctus Hieronymus compaginavit*:" while about the same time Belet writes that Pope Damasus requested St. Jerome to make a selection of Scriptures from the Old and New Testament to be read in the Church. The latter statement derives confirmation from the fact, that before the time of Damasus [A.D. 366—384] the Fathers cite Scripture without giving any indications of such a selection being in use: while after that time there are such indications in the writings of SS. Ambrose, Augustine, Leo, Salvian, and Casarius; the three latter of whom were accustomed to use St. Jerome's version of the Scriptures, and not the Septuagint. All this seems to show that there is much to be said for the ancient statement, that

³ Principles of Div. Serv. i. 369.

⁴ On the other hand, there are those who believe that many expressions in the New Testament Scriptures are derived from Liturgies known to and used by the Apostles. See an Essay on Liturgical quotations in Neale's *Liturgiology*, pp. 411—474.

St. Jerome first arranged the Epistles and Gospels, and that his arrangement is extant in this Lectionary.

In the Comes there are Scriptures for twenty-five Sundays after the Octave of Pentecost, as in our Prayer Book and in the ancient Salisbury Use (though in both the latter they are numbered as after Trinity), but the Roman rite has them only as far as the twenty-third Sunday after Pentecost. The Epistles and Gospels for these twenty-five Sundays and those for Advent exactly agree with the ancient and modern English, which (as will be seen in the tables annexed to every Sunday in the following pages) are quite different in arrangement from the Roman. The Comes also contains Epistles and Gospels for Wednesdays and Fridays in Epiphany, Easter, and Trinity seasons, which were in the Salisbury Missal, but are not in the Roman. It has also five Sundays before Christmas (that is, in Advent), instead of four, a peculiarity of notation which indicates very early origin, and which is reproduced in the "Sunday next before Advent" and four Sundays in Advent, of the English Use. These parallel peculiarities between the Comes and the English arrangement, differing as they do from the Roman, form a strong proof that our Eucharistic system of Scriptures had an origin quite independent of the Roman Liturgy; or, at least, that it belongs to a system which is much older than that now in use in the latter. It may be remarked, in conclusion, (and perhaps this is the most important fact in connexion with this diversity,) that the Collects, Epistles, and Gospels for Trinity Season are all in harmony in the English Missal, while that harmony is entirely dislocated in the Roman.

The principle on which portions of Holy Scripture are selected for the Epistles and Gospels is that of illustrating the two great divisions of the Christian year, from Advent to Trinity, and from Trinity to Advent. In the one, and more emphatic division, our Blessed Lord is set before us in a life-like diorama of Gospels, which tell us about Him and His work, not as in a past history, but with that present force, wherewith the events of His life and suffering are pleaded in the Litany. In nothing is the graphic action of the Church (sometimes very truly called 'historic') shown more strongly, than in the way by which the Gospels of the season are made the means of our living over again, year by year, the time of the Incarnation, from Bethlehem to Bethany; while in the long-drawn season of Trinity, we see the Church's continuance by the power of the Pentecostal outpouring in the true faith of the Blessed Trinity, and in the faithful following of her Master and Head through a long probationary career.

The special bearing of each Gospel and Epistle on the day for which it is appointed will be shown in the Notes that follow. It is sufficient here to say, in conclusion, that the existing arrangement of them appears to be founded on some more ancient system

of consecutive reading similar to that in use for our daily Lessons, a system still followed out in the East: that the Epistles have continued to be used in a consecutive order, but that the Gospels have been chosen with the special object of illustrating the season; or, where there is nothing particular to illustrate, of harmonizing with their respective Epistles. Whatever changes were made at the Reformation may be seen by the tabular arrangement under each Collect. In 1661 the only changes made were in the Gospels for the Holy Week, some of which were shortened by Bishop Cosin; in the insertion of those for a Sixth Sunday after Epiphany; and in printing all Gospels and Epistles from the Authorized Version of 1611, instead of from that of 1540.

[The Introits printed at the end of the Notes for each Sunday and other Festivals, are translated from the Salisbury Missal, the more familiar name of Introit having been substituted for that of "Officium," by which they are there designated. The Salisbury rubric directs them to be used in the following manner:—*"Officium missæ usque ad orationem prosequatur sacerdos: vel usque ad Gloria in excelsis: quando dicitur. Et post officium et psalmum repetatur officium: et postea dicitur Gloria patri et Sicut erat. Tertio repetatur officium: sequatur Kyrie."* Some of these Introits are selected with a striking appropriateness to the days for which they are appointed, and show a deep appreciation of the prophetic sense of Holy Scripture.

The Hymns are also those of the Salisbury Use, which, as is well known, it was the intention of Cranmer and his coadjutors to have translated into English with the Prayer Book. Most of the Hymns are to be found in the original Latin in "Hymni Ecclesiæ," published in 1865 by Macmillan. The references appended to each are to translations contained in the following well-known Hymn-books:—

- H. N. The Hymnal Noted. Where there is a double reference under these initials, it is (1) to the "Hymnal Noted" in two volumes, with the music; and (2) to the "Words of the Hymnal Noted."
- H. A. M. Hymns Ancient and Modern.
- C. H. The "Congregational Hymn and Tune Book," edited by the Rev. R. R. Chope.
- A. A. The "Appendix to the Hymnal Noted" used at St. Alban's Church, Holborn.
- D. H. The "Day Hours of the Church of England."

Want of space alone has prevented the Editor from giving the Hymns at length in the Notes; but the references thus inserted will indicate the ancient custom of the Church of England in using them; and may, perhaps, assist in establishing a more orderly use of the proper hymns of the Church for their appointed days and services.]

THE COLLECTS, EPISTLES, AND GOSPELS

TO BE USED THROUGHOUT THE YEAR.

See the rules given at p. 24. Minor Saints' days have no Vigils or Eves, nor Collects appointed.

¶ *Note, that the Collect appointed for every Sunday, or for any Holiday that hath a Vigil or Eve, shall be said at the Evening Service next before.*

THE FIRST SUNDAY IN ADVENT.

The Collect.

[A.D. 1549.]
Gen. xvii. 1.
James iv. 6.
John iii. 19—1.
Rom. xiii. 12, 13.
2 Cor. vi. 2.
Matt. xxi. 5.
Phil. ii. 5—8.
Matt. xxv. 31, 32.
2 Tim. iv. 1.
1 Thess. iv. 16, 17.
Rev. i. 8. xix. 16.

ALMIGHTY God, give us grace that we may cast away the works of darkness, and put upon us the armour of light, now in the time of this mortal life (in which thy Son Jesus Christ came to visit us in great humility); that in the last day, when he shall come again in his glorious Majesty to judge both the quick and dead, we may rise to the life immortal, through him who liveth and reigneth with thee and the Holy Ghost, now and ever.
Amen.

¶ *This Collect is to be repeated every day with the other Collects in Advent, until Christmas Eve.*

DOMINICA I. ADVENTUS DOMINI. Salisbury Use.

[Benedictio.]

OMNIPOTENS Deus vos placato vultu respiciat, et in vos donum suæ benedictionis infundat. Amen. Et qui hos dies incarnatione Unigeniti sui fecit solemnes a cunctis præsentis et futuræ vitæ adversitatibus reddat indemnes. Amen. Ut qui de adventu Redemptoris nostri secundum carnem devota mente lætamini, in secundo, cum in majestate venerit, præmiis æternæ vitæ ditemini. Amen.]

[Greg. Hebd. ii. ante Nat. Domini.]

	<i>Modern English.</i>	<i>Salisbury Use.</i>	<i>Modern Roman.</i>	<i>Eastern.</i> [29th Sy. from Whitsunday.]
EPISTLE.	Rom. xiii. 8—14.	Rom. xiii. 11—14.	Rom. xiii. 11—14.	Col. iii. 4—11.
GOSPEL.	Matt. xxi. 1—13.	Matt. xxi. 1—9.	Luke xxi. 25—33.	Luke xiv. 1—11.

ADVENT.

From the first institution of the great Festivals of the Church each of them occupied a central position in a series of days; partly for the greater honour of the Festival itself, and partly for the sake of Christian discipline. Thus Christmas is preceded by the Sundays and Season of Advent, and followed by twelve days of continued Christian joy which end with Epiphany.

Under its present name the season of Advent is not to be traced further back than the seventh century: but Collects, Epistles, and Gospels for five Sundays before the Nativity of our Lord, and for the Wednesdays and Fridays also, are to be found in the ancient Sacramentaries, and in the Comes of St. Jerome. These offer good evidence that the observance of the season was introduced into the Church at the same time with the observance of Christmas: yet there is not, properly speaking, any season of

Advent in the Eastern Church, which has always carefully preserved ancient customs intact; though it observes a Lent before Christmas as well as before Easter.

Durandus (a laborious and painstaking writer, always to be respected, though not to be implicitly relied upon) writes that St. Peter instituted three whole weeks to be observed as a special season before Christmas, and so much of the fourth as extended to the Vigil of Christmas, which is not part of Advent. [Durand. vi. 2.] This was probably a very ancient opinion, but the earliest extant historical evidence respecting Advent is that mentioned above, as contained in the Lectionary of St. Jerome. Next come two homilies of Maximus, Bishop of Turin, A.D. 450, which are headed *De Adventu Domini*. In the following century are two other Sermons of Cæsarius, Bishop of Arles [501—542], (formerly attributed to St. Augustine, and printed among his works,) and in these there are full details respecting the season and its

THE SECOND SUNDAY IN ADVENT.

DOMINICA II., ADVENTUS DOMINI.

Salisbury Use.

The Collect.

[A.D. 1549.]

Rom. xv. 4. 13.
John v. 39.
Luke viii. 18. 15.
Heb. ii. 1.

BLESSED Lord, who hast caused
all holy Scriptures to be written
for our learning; Grant that we may

observance. In the latter part of the same century St. Gregory of Tours writes, that Perpetuus, one of his predecessors, had ordered the observance of three days as fasts in every week, from the Feast of St. Martin to that of Christmas; and this direction was enforced on the Clergy of France by the Council of Maçon, held A.D. 581. In the Ambrosian and Mozarabic liturgies Advent Season commences at the same time: and it has also been sometimes known by the name *Quadragesima Sancti Martini*: from which it seems probable that the Western Churches of Europe originally kept six Advent Sundays, as the Eastern still keeps a forty days' Fast, beginning on the same day. But the English Church, since the Conquest, at least, has observed four only, although the title of the Sunday preceding the first seems to offer an indication of a fifth in more ancient days.

The rule by which Advent is determined defines the first Sunday as that which comes nearest, whether before or after, to St. Andrew's Day; which is equivalent to saying that it is the first Sunday after November 26th. December 3rd is consequently the latest day on which it can occur.

In the Latin and English Churches the Christian year commences with the First Sunday in Advent. Such, at least, has been the arrangement of the Collects, Epistles, and Gospels for many centuries, although the ancient Sacramentaries began the year with Christmas Day, and although the Prayer Book (until the change of style in 1752) contained an express "Note, that the Supputation of the year of our Lord in the Church of England beginneth the Five and Twentieth day of March." By either reckoning it is intended to number the times and seasons of the Church by the Incarnation: and while the computation from the Annunciation is more correct from a theological and a chronological point of view, that from Advent and Christmas fits in far better with the vivid system of the Church by which she represents to us the life of our Lord year by year. Beginning the year with the Annunciation, we should be reminded by the new birth of Nature of the regeneration of Human Nature: beginning it with Advent and Christmas, we have a more keen reminder of that humiliation of God the Son, by which the new birth of the world was accomplished. And as we number our years, not by the age of the world, nor by the time during which any earthly sovereignty has lasted, but by the age of the Christian Church and the time during which the Kingdom of Christ has been established upon earth, calling each "the Year of our Lord," or "the Year of Grace:" so we begin every year with the season when grace first came by our Lord and King, through His Advent in the humility of His Incarnation.

In very ancient times the season of Advent was observed as one of special prayer and discipline. As already stated, the Council of Maçon in its ninth Canon directs the general observance by the Clergy of the Monday, Wednesday, and Friday fast-days, of which traces are found at an earlier period: and the Capitulars of Charlemagne also speak of a forty days' fast before Christmas. The strict Lenten observance of the season was not, however, general. Amalarius, writing in the ninth century, speaks of it as being kept in that way only by the religious, that is, by those who had adopted an ascetic life in monasteries, or elsewhere: and the principle generally carried out appears to have been that of multiplying solemn services¹, and of adopting a greater reserve in the use of lawful indulgences. Such an observance of the season still commends itself to us as one that will form a fitting prefix to the joyous time of Christmas: and one that will also

¹ Our own Church had special Epistles and Gospels for the Wednesdays and Fridays in Advent, until the Reformation.

be consistent with that contemplation of our Lord's Second Advent which it is impossible to dissociate from thoughts of His First. In the system of the Church the Advent Season is to the Christmas Season what St. John the Baptist was to the First, and the Christian Ministry is to the Second, Coming of our Lord.

§ *The First Sunday in Advent.*

The four Sundays in Advent set forth, by the Holy Scriptures appointed for them, the Majesty of our Lord's Person and Kingdom. Christmas is to represent before us the lowliness to which the Eternal God condescended to stoop in becoming Man: and we begin on that day the detailed observance of each great Act in the mystery of the Incarnation. Before coming to Bethlehem and seeing the Holy Child in the manger, we are bidden to look on the glory which belongs to Him; and, ere we look upon the Babe of the humble Virgin, to prepare our hearts and minds for the sight by dwelling on the key-note which sounds in our ears through Advent, "Behold, thy King cometh:" a meek and lowly Babe, but yet Divine.

In this spirit the old Introit for the First Sunday was chosen, "Unto Thee lift I up mine eyes: O my God, I have put my trust in Thee . . ." though not without reference also to the humble dependence upon His Father with which the Son of God took human nature, and all its woes, upon Him. Lifting up our eyes to the Holy Child, we behold Him from afar, and "knowing the time, that now it is high time to awake out of sleep," we hear the cry, "Behold, the Bridegroom cometh" to His Church in a first Advent of Humiliation and Grace, and a second Advent of Glory and Judgment. For each Advent the Church has one song of welcome, "Hosanna to the Son of David: blessed is He that cometh in the Name of the Lord, Hosanna in the Highest; Even so come, Lord Jesus."

The Christian year opens, then, on this Sunday with a direct re-presentation of our Lord Jesus Christ to us in His Human Nature, as well as His Divine Nature, to be the Object of our Adoration. We cannot do otherwise than love the Babe of Bethlehem, the Child of the Temple, the Son of the Virgin, the Companion of the Apostles, the Healer of the Sick, the Friend of Bethany, the Man of Sorrows, the Dying Crucified One: but we must adore as well as love; and recognize in all these the triumphant King of Glory who reigns over the earthly Zion, and over the heavenly Jerusalem. No contemplation of the Humility of the Son of Man must divert our eyes from the contemplation of His Infinite Majesty of Whom the Father saith when He bringeth in the First-Begotten into the world, "Let all the angels of God worship Him."

INTROIT.—Unto Thee, O Lord, will I lift up my soul; my God, I have put my trust in Thee: O let me not be confounded, neither let mine enemies triumph over me. Ps. Show me Thy ways, O Lord, and teach me Thy paths. Glory be.

HYMNS.

EVENSONG. *Conditor alme siderum.* H. N. 10. 28, H. A. M. 81, C. H. 4.

MATTINS. { *Verbum supernum prodiens.* H. N. 11. 29, H. A. M. 32, C. H. 7.

{ *Vox clara ecce intonat.* H. A. M. 33, C. H. 3.

According to the Salisbury Use these Hymns are to be sung daily up to Christmas Eve.

§ *The Second Sunday in Advent.*

The note sounded by the Gospel of this Second Sunday is, "The

Deut. xxxii. 46. in such wise hear them, read, mark,
 47. learn, and inwardly digest* them, that
 Josh. i. 8. by patience, and comfort of thy holy
 Rev. i. 3. iii. 10. Word, we may embrace, and ever hold
 Heb. vi. *8—20. fast the blessed hope of everlasting
 life, which thou hast given us in our
 Saviour Jesus Christ. *Amen.*

	<i>Modern English.</i>	<i>Salisbury Use.</i>	<i>Modern Roman.</i>	<i>Eastern.</i>
EPISTLE.	Rom. xv. 4—13.	Rom. xv. 4—13.	Rom. xv. 4—13.	Col. iii. 12—18.
GOSPEL.	Luke xxi. 25—33.	Luke xxi. 25—33.	Matt. xi. 2—10.	Luke xiii. 10—17.

THE THIRD SUNDAY IN ADVENT.

The Collect.

[A.D. 1549.]
 Mark i. 2, 3.
 Luke i. 17. 76.
 Mat. iii. 1. iv.
 5, 6, with *Matt.*
 xi. 7, 8.
 1 Cor. iv. 1, 2, 5.
 Job xxviii. 28.
 2 Tim. iv. 1.
 Eph. i. 6.
 Heb. i. 8.

O LORD Jesu Christ, who at thy first coming didst send thy messenger to prepare thy way before thee; Grant that the ministers and stewards of thy mysteries may likewise so prepare and make ready thy way, by turning the hearts of the disobedient to the wisdom of the just, that at thy second coming to judge the world we may be found an acceptable people in thy sight, who livest and reignest with the Father and the Holy Spirit, ever one God, world without end. *Amen.*

DOMINICA III., ADVENTUS DOMINI. *Salisbury Use.*

	<i>Modern English.</i>	<i>Salisbury Use.</i>	<i>Modern Roman.</i>	<i>Eastern.</i>
EPISTLE.	1 Cor. iv. 1—5.	1 Cor. iv. 1—5.	Phil. iv. 4—7.	1 Tim. i. 15—17.
GOSPEL.	Matt. xi. 2—10.	Matt. xi. 2—10.	John i. 19—28.	Luke xiv. 16—24.

Kingdom of God is nigh at hand." As the Kingdom of Grace it is in the midst of us, so that the signs of its summer beauty and strength are visible to every eye that will look for them: as the Kingdom of the Second Coming, it is nigh at hand to all, for all must soon pass off of the one into the other. And what though the latter be terrible to contemplate, "men's hearts failing them for fear?" One has arisen to reign even over the Gentiles, and in Him shall the Gentiles trust. The patience and comfort of God's Holy Word, the Personal and the written Word, give the Church sure faith to look up and lift up its head, knowing that its redemption draweth nigh. "Because thou hast kept the word of My patience, I also will keep thee from the hour of temptation, which shall come upon all the world to try them that dwell upon the earth." [Rev. iii. 10.]

The continuity of the Church under the Old and New Dispensation is strongly shown in both the Epistle and the Gospel for this Sunday. In the first, the Monarchy of Christ over each Dispensation is set forth: in the second, the Parable of our Lord points to the Summer, which was to begin at His passing away. "Lo, the winter is past, the rain is over and gone; the flowers appear on the earth; the time of the singing of birds is come, and the voice of the turtle is heard in our land; the fig-tree putteth forth her green figs. Arise, my love, my fair one, and come away." [Cant. ii. 11—13.] It looks, also, beyond to that time when the Tree of Life will give its fulness of fruit, and the Kingdom of God be known in that phase of its continuous exist-

ence in which His servants shall serve Him, and they shall see His face, Who has been their Redemption.

INTROIT.—Behold, O people of Sion, the Lord will come to save the nations: and the Lord shall cause His glorious voice to be heard, and gladness shall be in your hearts. Ps. Hear, O Thou Shepherd of Israel, Thou that leadest Joseph like a sheep: Glory be.

§ *The Third Sunday in Advent.*

The Signs of Christ's Presence with His Church are shown by the Scriptures of to-day as a continuation of the truth enunciated on the Second Sunday, that the Kingdom of God is nigh at hand. Whether or not the faith of John the Baptist in the Lamb of God was imperfect, there were reasons why the faith of others should be made more perfect by means of the message which he sent to Jesus, "Art Thou He that should come, or do we look for another?" There was no outward show to signify the Infinite Glory that was dwelling in the lowly-born and lowly-living Man Who was in the midst of them. If indeed this was He that was to come, where was the fulfilment of all the well-known prophecies about the Majesty of the Messiah? For evidence, Christ did not transfigure His human Person before the multitude, and exhibit to them an unbearable glory, that would be as convincing as the burning bush, or the fire of Sinai: but "in the same hour He cured many of their infirmities and plagues, and of evil

THE FOURTH SUNDAY IN ADVENT.

The Collect.

Isa. li. 9. xl. 29.
Ps. lxxx. 2.
Rom. vii. 5. 23.
25.
Heb. xii. 1.
Ps. xl. 13. 17.
Rom. iii. 24-26.

O LORD, raise up (we pray thee) thy power, and come among us, and with great might succour us; that whereas, through our sins and wickedness, we are sore let and hindered in running the race that is set before us, thy bountiful grace and mercy may speedily help and deliver us, through the satisfaction of thy Son our Lord; to whom with thee and the Holy Ghost be honour and glory, world without end. *Amen.*

DOMINICA IV., ADVENTUS DOMINI,
* AD MISSAM.

Oratio.

EXCITA, quæsumus, Domine, potentiam tuam et veni, et magna nobis virtute succurre; ut per auxilium gratiæ tuæ quod nostra peccata præpediunt, indulgentia tuæ propitiationis acceleret. Qui vivis et regnas cum Deo Patre.

Salisbury Use.
Greg. Dom. I.
ante Nat.
Dom.
Gelas. 80 Orat.
de Adv. Dom.

	<i>Modern English.</i>	<i>Salisbury Use.</i>	<i>Modern Roman.</i>	<i>Eastern.</i>
EPISTLE.	Phil. iv. 4-7.	Phil. iv. 4-7.	1 Cor. iv. 1-5.	Heb. xi. 2. x. 32-40.
GOSPEL.	John i. 19-28.	John i. 19-28.	Luke iii. 1-6.	Matt. i. 1-25.

spirits; and unto many that were blind He gave sight" [Luke vii. 21]: and when He had done this His answer to the messengers was, "Go and show John again those things which ye do hear and see." It was thus the King's Presence was to be manifested among that generation. "Say to them that are of a fearful heart, Be strong, fear not: behold, your God will come with vengeance, even God with a recompence: He will come and save you. Then the eyes of the blind shall be opened, and the ears of the deaf shall be unstopped; then shall the lame man leap as an hart, and the tongue of the dumb sing; for in the wilderness shall waters break out, and streams in the desert." [Isa. xxxv. 4-6.] It is also in His work of healing that the same Saviour manifests His continued Presence with His Church. As He sent forth His agents then to carry on His work, in the person of Apostles, so does He send forth the ministers and stewards of His mysteries now. The one and the other both act by His authority, are endowed with His power, and do His work. As His ministers they have in past generations opened the eyes of the spiritually blind, healed spiritual infirmities by the ministration of their Master's grace, and made life-giving streams of Sacramental power to spring up in the wildernesses and deserts of the world. As, therefore, the Divine power gave evidence of the Divine Presence to those who were sent to ask, "Art Thou He that should come?" so the Divine power still gives evidence that the promise is fulfilled, "Lo, I am with you alway, even to the end of the world." The hearts of the disobedient are turned to the wisdom of the just, the children of men are made the children of God, souls are absolved by the Word of our God and Saviour pronounced at His bidding and by His agents, lively stones are being continually built up into the Temple of the Holy Ghost, which is the Mystical Body of Christ; and in all these ways the perpetual Presence of "Him that should come" is manifested, with as convincing an evidence as if our eyes beheld Him reigning on a visible Throne of Glory.

This view of these Scriptures shows their connexion with the Advent Ordination: and it was this view, doubtless, which led Bishop Cosin to compose the Collect that we now use in the place of a short one which stood here until 1661, in these words: "Lord, we beseech Thee give ear to our prayers, and by Thy gracious visitation lighten the darkness of our hearts, by our Lord Jesus Christ." This ancient Collect is erased in the Durham Book, and our present one written against it in the margin¹.

¹ The first Ember Collect was also composed by Bishop Cosin.

The Advent Ember Days are the Wednesday, Friday, and Saturday after St. Lucy's Day, which is December 13th. They always occur, therefore, in the third week of Advent, and their relative position in regard to Advent Sunday is shown by the following table:—

Advent Sunday.	Ember Wednesday.
November 27.	December 14.
" 28.	" 15.
" 29.	" 16.
" 30.	" 17.
December 1.	" 18.
" 2.	" 19.
" 3.	" 20.

As December 17th must thus always come in Ember Week, the Ember Collect should always be used from the Saturday Evensong preceding the 17th, according to the rule shown at page 63, on whatever day of the week the 17th may happen to fall.

INTROIT.—Rejoice in the Lord alway: and again I say, Rejoice. Let your moderation be known unto all men. The Lord is at hand. Be careful for nothing: but in every thing by prayer and supplication, let your requests be made known unto God. Ps. And the peace of God, which passeth all understanding, shall keep your hearts and minds. Glory be.

§ *The Fourth Sunday in Advent.*

On this Sunday, the close approach of the King of Glory to His kingdom of grace is heralded by Scriptures of which the pointed words are, "The Lord is at hand," "Make straight the way of the Lord." The Collect has lost its Gregorian pointedness by a return to its Gelasian form, which makes the whole a Prayer for the Presence of God the Father, instead of what it was originally, one for the Coming among us of God the Son. The alteration was probably made under a strong impression of the truth that all prayer should be addressed to the Father through the Son; and also with reference to the words spoken by our Lord immediately after He had given the command respecting prayer, and had promised a return of His own Presence, "If a man love Me, he will keep My words, and My Father will love

THE NATIVITY OF OUR LORD,
or the Birth-Day of Christ, commonly called
CHRISTMAS-DAY.

The Collect.

[A.D. 1549.]

John iii. 16. i. 14.
Heb. ii. 16.
Isa. vii. 14, with
Matt. i. 22, 23.
John iii. 3-5.
i. 12, 13.
Tit. iii. 5.
Rev. xi. 15.

ALMIGHTY God, who hast given us thy only-begotten Son to take our nature upon him, and as at this time to be born of a pure Virgin; Grant that we being regenerate, and made thy children by adoption and

DIES NATIVITATIS DOMINI.

Salisbury Use.
[Mozarabic
Breviary at
Lauds.]

DOMINE Jesu Christe, qui ex Patre Deus magnus, pro nobis dignatus es nasci ex homine parvus, ut per te factus, per te salvaretur sine dubio mundus; propitius esto et miserere nobis; nosque a mundanis con-

him, and We will come unto Him, and make Our abode with him." [John xiv. 23.] In Collect and Scriptures the Church sounds her last herald-notes of the season which precedes Christmas; and we seem to hear the cry of the procession, as it draws nearer and nearer, "The Bridegroom cometh; go ye forth to meet Him." It is a cry that should bring peace and joy to her children. "Rejoice in the Lord alway," for "One standeth among you," even now, who brings down from on high "the peace of God which passeth all understanding."

A very striking accidental coincidence with this joyous tone of the Fourth Sunday in Advent occurs in the First Lesson for Christmas Eve, "Arise, shine, for thy Light is come, and the glory of the Lord is risen upon thee. For, behold, darkness shall cover the earth, and gross darkness the people: but the Lord shall arise upon thee, and His glory shall be seen upon thee." The words sound like an answer from heaven to the prayers of Advent, that the Light would vouchsafe to come, and illuminate the Church with His Presence. Other words which follow are equally striking, and offer themselves as a benediction of the Christmas decorations which have just been completed: "The glory of Lebanon shall come unto thee, the fir-tree, the pine-tree, and the box together, to beautify the place of My sanctuary; and I will make the place of My feet glorious."

The following Antiphons to the Magnificat were formerly sung during the third and fourth weeks of Advent. In later times, two others were added, one for the Festival of St. Thomas, and another in which the name of the Blessed Virgin was used as we are not now accustomed to use it. But the original set of Antiphons appears to have consisted of these seven, the first being sung on December 16th, which is still marked "O Sapientia" in the Calendar, and none being used on the Festival of St. Thomas, or on Christmas Eve, the latter not being part of the Advent season. The dates on which they would thus fall are affixed to each Antiphon. References are also appended to the passages of Holy Scripture that contain or illustrate the respective titles of our Lord on which each Antiphon is founded, as these Antiphons are excellent examples of the manner in which Scriptural ideas and words may be used in direct acts of Adoration.

December 16th. [Eccclus. xxiv. 3. Wisd. viii. 1. Cf. 1 Cor. i. 24. Prov. i.—ix.]

O Wisdom, which didst come forth from the mouth of the Most High, reaching from the one end of all things to the other, and ordering them with sweetness and might: Come, that Thou mayest teach us the way of understanding.

December 17th. [Exod. iii. 14. John viii. 58.]

O Lord of lords, and Leader of the house of Israel, who didst appear unto Moses in a flame of fire in the bush, and gavest Thy law in Sinai: Come, that Thou mayest redeem us with Thy stretched-out arm.

O Sapientia quæ ex ore Altissimi prodisti, attingens a fine usque ad finem, fortiter suaviterque disponens omnia; veni ad docendum nos viam prudentiæ.

O Adonai, et dux domus Israël, qui Moysi in igne flammæ rubi apparuisti, et in Sina legem dedisti; veni ad redimendum nos in brachio extento.

December 18th. [Isa. xi. 10. Rev. xxii. 16.]

O Root of Jesse, which standest for an ensign of the people, before whom kings shall shut their mouths, and to whom the Gentiles shall seek: Come, that Thou mayest deliver us; tarry not, we beseech Thee.

O Radix Jesse, qui stas in signum populorum; super quem continebunt reges os suum, quem gentes deprecabuntur; veni ad liberandum nos: jam noli tardare.

December 19th. [Isa. xxii. 22. Rev. iii. 7. Isa. xlii. 7.]

O Key of David, and Sceptre of the house of Israel: Thou who openest and no man shutteth, who shuttest and no man openeth: Come, that Thou mayest bring forth from the prison-house him that is bound, sitting in darkness and in the shadow of death.

O Clavis David, et Sceptrum domus Israël: Thou who aperis et nemo claudit, claudis et nemo aperit; veni et edue vincitum de domo carceris, sedentem in tenebris et umbra mortis.

December 20th. [Wisd. vii. 26. Heb. i. 3. Mal. iv. 2.]

O dawning brightness of the everlasting Light, and Sun of Righteousness: Come, that Thou mayest enlighten those who sit in darkness and in the shadow of death.

O oriens Splendor lucis æternæ et Sol justitiæ; veni et illumina sedentes in tenebris et umbra mortis.

December 22nd. [Hag. ii. 7.]

O King and Desire of all nations, the Corner-Stone uniting all in one: Come, that Thou mayest save man, whom Thou hast formed out of the ground by Thy hand.

O Rex gentium et Desideratus earum, lapisque angularis qui facis utraque unum; veni, salva hominem quem de limo formasti.

December 23rd. [Isa. vii. 14. Matt. i. 23.]

O Emmanuel, our King and our Lawgiver, the Expectation and the Saviour of the Gentiles: Come, that Thou mayest save us, O Lord our God.

O Emmanuel, Rex et Legifer noster, expectatio gentium et salvator earum; veni ad salvandum nos, Domine Deus noster.

INTROIT.—Drop down ye heavens from above, and let the skies pour down righteousness: let the earth open, and let them bring forth salvation [germinet Salvatorem]. Ps. And let righteousness spring up together. I the Lord have created It. Glory be.

CHRISTMAS DAY.

The Festival of Christmas was observed at a very early period in the Church, as indeed it could hardly but be; for that which brought the joy of angels within reach of men's ears, could not but have been devoutly and joyously remembered by Christians, year by year, when they came fully to understand the greatness of the event. St. Chrysostom, in a Christmas homily, speaks of the festival as being even then, in the fourth century, one of great antiquity; and, in an Epistle, mentions that Julius I. [A.D. 337—352] had caused strict inquiry to be made, and had confirmed the observance of it on December 25th. There are sermons extant which were preached upon this day by Gregory

grace, may daily be renewed by thy Holy Spirit; through the same our Lord Jesus Christ, who liveth and reigneth with thee and the same Spirit, ever one God, world without end. Amen.

tagiis munda, et in hoc mundo mundos nos esse constitue, qui non iudicare, sed salvare venisti, ut nobis parvulus natus, nobisque filius datus, in te et regenerationis ortum et adoptionis mereamur consequi donum. Amen. Per misericordiam tuam Deus noster.]

	<i>Modern English.</i>	<i>Salisbury Use.</i>	<i>Modern Roman.</i>	<i>Eastern.</i>
EPISTLE.	Heb. i. 1—12.	{ I. Titus ii. 11—15. II. Titus iii. 4—7. III. Heb. i. 1—13.	Titus ii. 11—15. Titus iii. 4—7. Heb. i. 1—12.	.
GOSPEL.	John i. 1—14.	{ I. Luke ii. 1—14. II. Luke ii. 15—20. III. John i. 1—14.	Luke ii. 1—14. Luke ii. 15—20. John i. 1—14.	Matt. i. 18—25.

Nazianzen and St. Basil, in the same century. It is spoken of by Clemens Alexandrinus, who died in the beginning of the third century, a little more than a hundred years after the death of St. John; and it was on Christmas Day that a whole church full of martyrs was burnt by Maximin, in Nicomedia.

In the primitive age of the Church, this Festival was more closely associated with the Epiphany than it has been in later times. The actual Nativity of Christ was considered as His first Manifestation, and the name "Theophania" was sometimes given to the day on which it was commemorated, as well as to the twelfth day afterwards, when the end of the Christmas Festival is celebrated with other memorials of the appearance of God among men. Most of the Fathers have left sermons which were preached on Christmas Day, or during the continuance of the festival; and secular decrees of the Christian Emperors, as well as Canons of the Church, show that it was very strictly observed as a time of rest from labour, of Divine Worship, and of Christian hilarity.

The ancient Church of England welcomed Christmas Day with a special service on the Vigil, a celebration of the Holy Communion soon after midnight, another at early dawn, and a third at the usual hour of the mid-day mass. The first two of these services were omitted from the Prayer Book of 1549, and the third from that of 1552. But, an early Communion, as well as the usual mid-day one, has always been celebrated in some of the greater churches on Christmas Day, and custom has revived the midnight celebration also, in addition to the ordinary Evensong of Christmas Eve. The midnight celebration commemorates the actual Birth of our Lord; the early morning one its revelation to mankind in the persons of the shepherds; that at mid-day the Eternal Sonship of the Holy Child Jesus.

The Collect at the Early Communion in the first Prayer Book was that of Christmas Eve in the Salisbury Missal: the Epistle and Gospel being the first of the ancient three.

Early Communion. First Prayer Book of 1549. *Christmas Eve. Salisbury Use.*

God, which makest us glad with the yearly remembrance of the birth of Thy only Son Jesus Christ; grant that as we joyfully receive Him for our Redeemer, so we may with sure confidence behold Him, when He shall come to be our Judge, who liveth and reigneth.

Deus, qui nos redemptionis nostræ annua expectatione lætificas: præsta: ut Unigenitum tuum quem redemptorem læti suscipimus: venientem quoque iudicem securi videamus Dominum nostrum Jesum Christum Filium tuum. Qui tecum. [Greg. In Vig. Nat. Dom. ad Nonam. Gelas.]

The ancient association of Christmas and Epiphany was maintained in the Collect of the Salisbury Use, *Ad Missam in galli cantu*. "Deus, qui hanc sacratissimam noctem veri luminis fecisti illustratione clarescere: da, quæsumus, ut cujus lucis mysteria in terra cognovimus, ejus quoque gaudiis in cælo perfruamur. Qui tecum." [Greg. In Vig. Dom. in Nocte. Gelas.]

It is most fit that the season so marked out by Angels by songs of joy, such as had not been heard on earth since the Creation, should also be observed as a time of festive gladness by the Church, and in the social life of Christians. Christ Himself instituted this festival when He sanctified the day by then first revealing His Human Nature to the eyes of mankind. The holy Angels witnessed to its separation for ever as a day of days, when they proclaimed the Glory that was then offered to God in the Highest by the restoration of perfect Manhood in the Virgin-born Jesus; and the peace that was brought among men on earth through the reunion of their nature to God. The whole world has since recognized it as the single point of history in which every age, every country, every living man has an interest. It is to the Nativity of our Lord that all the pages of the Bible point as the centre on which every thing there recorded turns. Kings have lived and died; empires have arisen and crumbled away; great cities have been built and destroyed; countries peopled and again laid desert: and all this is to us almost as if it had never been. Great as past events of history were to the generations in which they occurred, to us they are of less practical importance than the every-day circumstances of our common life. But the event which gives us the festival of Christmas was one whose interest is universal and unfading: one with which we are as much concerned as were the shepherds of Bethlehem: and which will be of no less importance to the last generation of men than it is to us. For it was in the Birth of Christ that Earth was reunited to Heaven, and both made one Kingdom of God above and below, as they were at the first Creation. In it, separation of man from God was done away, for One appeared Who in His own single Person was God, belonging to Heaven, and Man, belonging to earth. It was not only the beginning of a new era, but it was the Centre of all human history, the point of time to which the ages that were gone had looked forward, and to which the ages that were to come after must all look back; the one day of days which gathered all other times into itself, and stretching its influence through every hour of human existence from the Fall to the Judgment, makes for itself a history by connexion with which only can other histories have an eternal interest. And so, even beyond the immediate influence of the Church, it is found that the Christmas gladness of the Church is reflected in the world around: and a common instinct of regenerated human nature teaches that world to recognize in Christmas a season of unity and fellowship and goodwill, of happiness and peace.

INTROIT.—Unto us a Child is born, unto us a Son is given, and the government shall be upon His shoulder; and His name shall be called Wonderful. Ps. Sing unto the Lord a new song, for He hath done marvellous things. Glory be.

HYMNS.

EVENSONG.— { *Veni Redemptor Gentium.* H. N. 12. 31.
 { *Salvator mundi, Domine.* H. A. M. 49, C. H. 24.

S. STEPHEN'S DAY.

The Collect.

[A. D. 1661.]
John xv. 20.
1 Pet. iv. 13,
14, 19.
Acts vii. 55, 56.
2 Cor. iv. 17, 18.
Acts vii. 57—60.
Matt. v. 44.

GRANT, O Lord, that, in all our sufferings here upon earth for the testimony of thy truth, we may stedfastly look up to heaven, and by faith behold the glory that shall be

IN DIE SANCTI STEPHANI.

Oratio.

DA nobis, quæsumus, Domine, imitari quod colimus, ut discamus et inimicos diligere, quia ejus natalitia celebramus, qui novit etiam pro persecutoribus exorare Dominum nostrum

Salisbury Use.
Greg. Nat.
S. Steph.

MATTINS. *Christe, Redemptor omnium.* H. N. 13. 33, H. A. M. 45, C. H. 21.
A solis ortus cardine. H. N. 14. 34.

These hymns are appointed for all days throughout the Octave which are not otherwise provided for.

THE THREE DAYS AFTER CHRISTMAS.

The position of the three days after Christmas Day is a very remarkable one. Easter and Pentecost each have two festive days following their principal day, the Sunday: and in this respect Christmas, with its three festive days, is placed on a similar though a more honoured footing. But at Easter and Pentecost the days are connected by name with the festival itself, whereas, at Christmas, they are associated with the names of Saints, in addition to that continued commemoration of the Nativity which belongs to them as to the other days of the Octave.

Some explanation of this may be found in the vivid convictions of the early Church respecting the close union between Christ and His people, especially His Martyrs, through the virtue of the Incarnation. Eusebius [viii. 10] speaks of the martyrs of Alexandria as *Χριστοφόροι*, a name otherwise familiar to us in the story of St. Christopher, and in the appellation of Theophorus which was given by himself or others to Ignatius: and St. Augustine, in one of his Sermons on St. Stephen's Day, seems to adopt a strain of thought in accordance with these names, when he says, "As Christ by being born was brought into union with Stephen, so Stephen by dying was brought into union with Christ." There was, moreover, in the early Church (itself so familiar with a life of suffering) a profound sense of the continuous martyrdom which was involved in the earthly life of our Lord, both from the intensity of the humiliation which He underwent in becoming Man [non horruisti virginis uterum. *Te Deum*], and also from the sorrows which were inherent in His human nature as the bearer of all human woes. Hence they could not lose sight, in those days, of the fact that the Holy Child of Bethlehem was also the Man of Sorrows: and it is very probable that this view of our Lord's Incarnation led to the commemoration of the first Martyr who suffered on the day succeeding that on which his Master had entered on a life of suffering, rather than on the anniversary of his martyrdom. In connexion with this view it is very observable, that at the first taste of martyrdom, even before the suffering of St. Stephen, the Church pleaded the Divine Sonship and human Infancy of our Lord: and although few of the Apostles are likely to have known their Lord in His childhood, (while His mature years and His final work were familiar to all, and His Ascent out of their sight as Man vividly fresh in their memory,) yet they speak of Him to the Father in their hour of trouble as "Thy holy Child Jesus," and seem thus to fall back, so to speak, on the first days of the Incarnation more than a third of a century before, rather than on their recent knowledge of Him through whom they prayed for strength to do and bear all that was set before them. It may well have been that St. Stephen was among them when the words of that prayer were used.

Another explanation is to be found in the Rationale of Durandus [vii. 42]. The substance of this is, that Christ being the Head to which all the members are joined, three kinds of members are joined to Him by martyrdom: as mystically signified in the Song of Songs [v. 10], by the words, "My Beloved is white and ruddy, and the chiefest among ten thousand." The first and chief order of martyrs he thus considers to be those who, being baptized in blood, suffered both in will and deed: the

second, those who gave their will up entirely to suffer, but yet escaped with life, and so accomplished a white martyrdom: the third, those who suffered but had no wills of their own to sacrifice to God, as was the case with the Holy Innocents.

One other view may be named; which is, that as the second half of the Christian year represents the Christian life founded on the life of Christ, so the three days after Christmas represent the three ways of suffering, love, and purity, by which the Incarnation bears fruit in the saints of God. St. Stephen was the nearest to the King of Saints in His life of suffering, St. John in His life of love, the Holy Innocents in His life of purity. The first trod immediately in his Master's footsteps of a Martyr death in its most perfect form; the second lying on Jesus' bosom in close communion with Him to the end of His earthly life, followed Him closely ever after in His heavenly example; the third were the first-fruits of that holy train whose innocence and purity admits them nearest to the Person of their glorified Redeemer, so that "they follow the Lamb whithersoever He goeth."

§ *St. Stephen.*

Nothing is known of St. Stephen before his martyrdom beyond the solitary fact that he was one of the seven deacons ordained by the Apostles when they began to divide off the lower portions of their ministerial functions, duties, and cares. His eloquence, ready knowledge, heroic courage, are strikingly exhibited in the account given of his last hours in the seventh chapter of the Acts. It may be that he is only a fair and average example of those wonderfully endowed men who carried on Christ's work in the Apostolic age; and that the peculiarity of his martyrdom as being the first, and as occurring while the Church was still confined almost within the walls of Jerusalem, has given it the prominence of a Scriptural narrative. There were, doubtless, many others in that holy band of Apostolic men, of whom it might have been recorded that, "full of faith and power, they did great wonders and miracles among the people;" and many who suffered as boldly and as meekly as St. Stephen. Yet it is around the head of the Proto-martyr alone that Holy Scripture places the nimbus of glory; and however truly it may be the due of others also, it is of St. Stephen only that the words are written, "And all that sat in the council, looking stedfastly on him, saw his face as it had been the face of an angel." Hence St. Chrysostom calls him the *Στέφανος* or crown of the Church, in respect to her martyrdoms.

The dying words of St. Stephen are also of a most saint-like character, whether that character was common to the saintly martyrs or not. The last words of his Master's passion, "Father, forgive them, for they know not what they do," have a parallel in the servant's, "Lord, lay not this sin to their charge;" and the commendatory prayer, "Lord Jesus, receive my spirit," is the saint's version of the Son's cry, "Father, into Thy hands I commend My spirit."

Such circumstances as these seem as if they were providentially ordered, in part, as a monition to the Church of the honour in which the martyrs of Christ were ever after to be held; to show her that Christ was to be glorified in His saints, through whom the lustre of His own Light was shed around as planets disperse the light of the sun when it is beyond our horizon. Nor must it be forgotten that the narrative of St. Stephen's martyrdom is given us in that book which is principally made up of the Acts of St. Paul, the account of the missionary life and sufferings—and how small a part!—of that "young man whose name was

Heb. ii. 18. vii. 25. revealed; and, being filled with the Holy Ghost, may learn to love and bless our persecutors by the example of thy first Martyr Saint Stephen, who prayed for his murderers to thee, O blessed Jesus, who standest at the right hand of God to succour all those that suffer for thee, our only Mediator and Advocate. *Amen.*

¶ *Then shall follow the Collect of the Nativity, which shall be said continually unto New-year's Eve.*

Jesum Christum Filium tuum qui tecum vivit et regnat.

¶ *Alia de Nativitate.*

	<i>Modern English.</i>	<i>Salisbury Use.</i>	<i>Modern Roman.</i>	<i>Eastern.</i>
EPISTLE.	Acts vii. 55—60.	Acts vi. 8—10. vii. 54—60.	Acts vi. 8—10. vii. 54—60.	Heb. ii. 11—18.
GOSPEL.	Matt. xxiii. 34—39.	Matt. xxiii. 34—39.	Matt. xxiii. 34—39.	Matt. xxi. 33—43.

S. JOHN THE EVANGELIST'S DAY.

The Collect.

1 John i. 5.
John viii. 12.
Rev. i. 1. xiv. 6.
1 John i. 3—6.
John xii. 35.

MERCIFUL Lord, we beseech thee to cast thy bright beams of light upon thy Church, that it being

IN DIE SANCTI JOHANNIS EVANGELISTÆ.

Oratio.

ECCLESIAM tuam quæsumus, Domine, benignus illustra; ut beati Joannis apostoli tui et evange-

Saul," at whose feet the official "witnesses" of the cruel and sudden death "laid down their clothes." Were all these official μαρτυρες won over to be martyrs in life and death as that young man was? Whether or not such fruit was borne by the first martyr's blood, it is certain that all the members of the then existing Church must have had his death keenly engraved on their memory; and that, as Christ ordained Christmas Day by the very fact of His Nativity, so His holy Martyr must have been privileged to originate the observance of Saints' Days by the very circumstances of that Martyrdom whereof the Church, and the Apostle of the Gentiles above all, must have said year by year, This was the day on which Stephen fell asleep.

The Collect for St. Stephen's Day, as it now stands, is first found, in Bishop Cosin's handwriting, in the margin of the Durham Prayer Book. Until 1661 it was used in this much shorter and less beautiful form,—“Grant us, O Lord, to learn to love our enemies, by the example of Thy martyr, Saint Stephen, who prayed for his persecutors to Thee; which livest.” It is observable that in both forms of this Collect it follows the example given by St. Stephen, of prayer to the second Person of the Blessed Trinity. The following passage from the *Contestatio Missæ* of the Gallican Mass for St. Stephen's Day, printed by Cardinal Bona [Rer. Liturg. i. 12], is very like the newer portion of our Collect,—“Illi pro nobis oculi sublimentur, qui adhuc in hoc mortis corpore constituti stantem ad dexteram Patris Filium Dei, in ipsa passionis hora viderunt. Ille pro nobis obtineat, qui pro persecutoribus suis, dum lapidaretur, orabat ad Te Sancte Deus, Pater omnipotens.” This was not printed by Bona until 1676, but it is an interesting illustration of the unity which pervades the tone of ancient and sound modern forms of prayer.

INTROIT.—Princes also did sit and speak against me. They persecute me falsely; be Thou my help, O Lord my God: because Thy servant is occupied in Thy statutes. Ps. Blessed are those that are undefiled in the way, and walk in the law of the Lord. Glory be.

HYMN.

MATTINS and EVENSONG. *Sancte Dei pretiose.* H. N. 15. 40.

§ *St. John the Evangelist.*

The beloved disciple of the Holy Child Jesus is known to the affection of the Church as the Apostle of Love, to her intellect as the Θεολόγος, or Divine. There is little recorded of him in Holy Scripture, but a large part of the New Testament was revealed by God to His servant John; and none of the Apostles, so far as we know, except St. Paul, exercised so extensive an influence over the subsequent ages of the Church. It is not known how soon a festival was instituted in honour of this Apostle, but it is placed in the ancient Sacramentaries and Lectionary, and is therefore of primitive origin.

St. John the Evangelist was one of the sons of Zebedee and Salome, a fisherman like his father, and early called by our Blessed Lord to be a fisher of men. With three other of the Apostles he stood in a near relationship to the Blessed Virgin, which may be best represented by the following table.

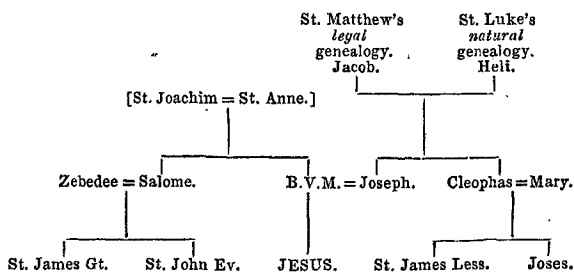

The intimate relationship between the Blessed Virgin Mary and her cousin Elizabeth seems to make it probable that the son of her sister Salome would become an early disciple of St. John the Baptist; and as his follower he was in company with St. Andrew when the Baptist bore official witness to the Mission of our Lord as "the Lamb of God which taketh away the sin of the world." The Evangelist, therefore, was one of the first pair of disciples who were called from following the Law to follow the Gospel: sharing indeed with St. Andrew in the honour of the title Πρωτόκλητος. It would appear to have been some little time afterward that St. John was required to give up his ordinary

Rev. xxi. 10, 23, enlightened by the doctrine of thy
24. blessed Apostle and Evangelist Saint
John may so walk in the light of thy
truth, that it may at length attain to
the light of everlasting life, through
Jesus Christ our Lord. *Amen.*

listæ illuminata doctrinis, ad dona per- Cf. Aug. in
veniat sempiterna. Per Dominum. Joan. ii. 7.

*Memoria de Nativitate. Alia de
Sancto Stephano.*

	<i>Modern English.</i>	<i>Salisbury Use.</i>	<i>Modern Roman.</i>	<i>Eastern.</i>
EPISTLE.	1 John i. 1—10.	Ecclus. xv. 1—6.	Ecclus. xv. 1—6.	1 John iv. 12—19.
GOSPEL.	John xxi. 19—25.	John xxi. 19—24.	John xxi. 19—24.	John xix. 25—29, and xxi. 24, 25.

occupation that he might be trained to the office of a fisher of men, and become a constant attendant on our Lord: still longer before that training had been so far carried on as to qualify him in outward knowledge for receiving the commission and power of an Apostle. In the appointment of the Apostles, St. John was one of the three whom our Lord distinguished by new names: he and his brother St. James being then called Boanerges, a title which ancient writers connect with the great eloquence of these two Apostles, as Demosthenes and Plato were called "tonantes" by old Roman writers. This does not seem quite to explain the title: yet in the case of St. John it is easy to see that it might have such a prophetic application to him as the last writer of the New Testament, who was to proclaim resounding theological truths to the world as from a Gospel Sinai after historical narratives had done their work in preparing the minds of men for their reception.

The next time St. John's name occurs in the Gospels is as one of the three "elect of the elect" who were chosen by our Lord to witness the manifestation of His Divine power in the chamber of Jairus's daughter, and of His Divine glory on the Mount of Transfiguration. The same three were also present at the Agony. They seem to have been chosen, not for any purpose of sympathy needed by Christ, but as a part of their own training. All three were afterwards distinguished by special services for their Master, and these visions of His Power, His Glory, and His suffering were preparing them for their work. Of the two sons of Zebedee, St. James was the first martyred Apostle, St. John the latest living Apostle. The first miracle of the Church was wrought by St. Peter and St. John; they, too, were the first sufferers after the Ascension; they were the first Apostles who went beyond Judæa; and they were the "pillars" of the Church in its early days. If we reckon up the extent of their work in the education of the Church, it will be found that far the greatest proportion of the New Testament has come from the pens of St. Peter, St. Paul, and St. John; the second great Apostle appearing to have filled up the vacancy caused by the martyrdom of St. James. And as St. Peter exercised a vast external influence over the Church of the Future, while St. Paul was its great moral teacher, so St. John the Theologian was the Apostle by whom the world was to learn more than by any other, those truths which lie at the very root of orthodox and true conceptions respecting the Blessed Trinity, our Redeemer, and the work of the Incarnation in making God and man at one. The Church of England traced up its usages in primitive days to the teaching of St. John, and there is good reason to think that the influence of this Apostle has moulded her Liturgy and her spirit very extensively; preparing her, perhaps, for the great struggle against unbelief in which she seems destined to bear a prominent part.

The Blessed Virgin having been committed to the care of St. John the Evangelist at the Cross, his office towards her appears to have terminated about the year 48, but between that time and the later part of the century his history is in obscurity. Possibly it was part of the fulfilment of the Lord's words, "If I will that he tarry till I come," that St. John should really see Jerusalem

encompassed with armies, and that he did not leave for Ephesus until so late as the year 66, when the siege began: which was only a year before the martyrdom of St. Peter and St. Paul. It was about this time, certainly, that the Evangelist and Theologian began to be the sole remaining Apostolic centre of the Church, as he continued to be for about a third of a century. This isolation of St. John sets him in a position of patriarchal prominence, greater even than that of St. Paul had been: and he was doubtless directed to Ephesus, the Metropolis of Asia, the great centre of nature-worship, and the commercial port of the one great sea of the then known world, as the place where his influence would extend farthest and widest during those eventful years in which the Church was breaking free from Judaism, and settling into definite forms of doctrine and worship.

The latter part of St. John's life was marked by two acts which fulfilled our Lord's words, that he should tarry until His Coming. A poisoned cup of wine was given to him at Ephesus, but the Apostle made over it the sign of the Cross, and partook of it without harm; according to the promise, that if the Apostles drank of any deadly thing it should not hurt them. He was also summoned to Rome, and there cast into a caldron of burning oil [see Calendar], but escaped unharmed. Banished to Patmos, the visions of the Apocalypse were revealed to him; and when his work was done there, his Master's Providence led him back to Ephesus, to contend against the rising heresies of the day, to speak loving words about the love of God, and to breathe out his spirit in peace at the age of 100 in the midst of his "little children,"—those whom he had begotten in Christ.

Lying on the bosom of his Master, not only in those few minutes in the upper chamber of the Institution of the Holy Eucharist, but ever after by contact of his spiritual senses with the Word of God, this holy Apostle learned things from the Divine lips and heart which had been kept secret from the foundation of the world; which the angels desired to look into, but could not until they were revealed to mankind. As St. John the Baptist, the last Prophet of the Old Dispensation, was the Forerunner of Christ, so it may be said that St. John the Evangelist, the Prophet of the New Dispensation, occupies a similar position as the Herald of the Second Advent; and for this reason, as well as others that have been stated, his Festival is connected so closely with Christmas. When He that enlighteneth every man came into the world, He cast some of the bright beams of His Light upon St. John, that by him the illumination of the world might be more perfect, and the Sun of Righteousness which had arisen with healing in His beams might shine more gloriously over the understandings and the love of His Church.

INTROIT.—In the midst of the Church did he open his mouth; and the Lord filled him with the spirit of wisdom and understanding. He endued him with a robe of glory. Ps. He poured out upon him His treasures of joy and gladness. Glory be.

HYMNS.

MATTINS.—*Annue Christe sæculorum Domine.* H. N. 86. 75.
EVENSONG.—*Exultet cælum laudibus.*

THE INNOCENTS' DAY.

IN DIE SANCTORUM INNOCENTIIUM Salisbury Use.
MARTYRUM,

Officium.

Ex ore infantium Deus et lactentium
perfecisti laudem: propter inimicos tuos.

Oratio.

DEUS cujus hodierna die præ- Greg., Gelas. Nat.
Innocent.
conium innocentes martyres,
non loquendo sed moriendo, confessi
sunt, omnia in nobis vitiorum mala
mortifica, ut fidem tuam, quam lingua
nostra loquitur, etiam moribus vita
fateatur. Qui cum Deo Patre.

*Memoria de Nativitate. Alia me-
moria de Sancto Stephano. Item alia
de Sancto Johanne.*

The Collect.

[A.D. 1661.]

Ps. viii. 2, with
Matt. xxi. 13,
16. ii. 16—18.
Rom. viii. 13.
Eph. iii. 13, 14.
Rev. xiv. 4, 5.
ii. 10.
Phil. i. 20.

O ALMIGHTY God, who out of
the mouths of babes and suck-
lings hast ordained strength, and
madest infants to glorify thee by their
deaths; Mortify and kill all vices in
us, and so strengthen us by thy grace,
that by the innocency of our lives,
and constancy of our faith even unto
death, we may glorify thy holy
Name; through Jesus Christ our
Lord. *Amen.*

	<i>Modern English.</i>	<i>Salisbury Use.</i>	<i>Modern Roman.</i>	<i>Eastern.</i>
EPISTLE.	Rev. xiv. 1—5.	Rev. xiv. 1—5.	Rev. xiv. 1—5.	Heb. ii. 11—18.
GOSPEL.	Matt. ii. 13—18.	Matt. ii. 13—18.	Matt. ii. 13—18.	Matt. ii. 13—23.

§ *The Holy Innocents.*

The festival of the Innocents is alluded to by St. Irenæus [Adv. Hæres. iii. 16], who was himself a martyr, A.D. 202; and by St. Cyprian, who went to his Saviour by the same path, A.D. 258. In an Epistle (lviii.) which the latter wrote to a community of Christians in anticipation of a fearful persecution which he foresaw, he says, "The Nativity of Christ commenced forthwith with the martyrdom of infants, so that they who were two years old and under, were put to death for His Name's sake. An age not yet capable of conflict, proved fit for a crown. That it might appear that they are innocent who are put to death for the sake of Christ, innocent infancy was slain for His Name's sake. It was shown that no one is free from the perils of persecution, when even such accomplished martyrdom."

These words of the third century plainly show how early the memorial day of the Holy Innocents was associated with Christmas: and allusions of the same kind are to be found in the Sermons of Origen, St. Augustine, and others.

The Gospel of this day gives the actual narrative of the slaughter of the children of Bethléhem by Herod, an event spoken of in Roman history as well as in the Holy Bible. The Epistle sets forth the heavenly sequel of that event as told in the mystical language of the Apocalypse. In the joining together of these two portions of Holy Scripture, we have an exact representation of the light in which the martyrdom of the Innocents has always been regarded by the Church: and the tender feeling with which these first witnesses for the Holy Child Jesus were kept in memory, is illustrated by the well-known hymn of Prudentius, written in the fourth century, and familiar in the English version, "All hail! ye Infant Martyr flowers."

"Not in speaking but in dying," says the ancient Collect, "have they confessed Christ." "Stephen," says St. Bernard, "was a martyr among men; John may be considered so in the sight of Angels, to whom by spiritual signs his devotion was known: but these are martyrs with God; for neither to men nor angels is their merit known, but commended to God alone in the prerogative of His singular grace." "Before the use of the tongue," writes St. Leo, "in silence He put forth the power of

¹ Used in that form until 1661.

the Word, as if He were saying already, 'Suffer little children to come unto Me, for of such is the Kingdom of Heaven.' With a new glory He crowned infants, and in His own beginnings consecrated the first-fruits of little children; that hence we might learn that no one among mankind is incapable of a Divine Sacrament, since even that age was fit for the glory of martyrdom. . . . Christ loves infancy, which He took on Himself both in mind and body: He loves infancy as the mistress of humility, the type of innocence, the form of meekness. To infancy He directs the manners of elders, and brings back the old. It is to this, the similitude of little children, that you, most beloved, are invited by the mystery of this day's festival."

In connexion with these holy Innocents, it is impossible not to remember the words at the end of the Service for the Baptism of Infants, "It is certain by God's Word, that children which are baptized, dying before they commit actual sin, are undoubtedly saved." The writer once met with a strong illustration of the comfort wrought by faith in this truth, when looking over a country churchyard. A mother had laid underneath two Christian babes, and she had written on the stone over them, "They are without fault before the throne of God." Doubtless, many such have been added to the mystical number since St. John wrote down his Vision, "first-fruits unto God and to the Lamb," taken away from the evil to come, and gaining the fullest benefit of the Holy Child's Nativity by the way of Innocence in which they have been privileged to follow Him on Earth, that they may "follow Him whithersoever He goeth" in Heaven. "So He giveth His beloved sleep."

The mournful character of this day was anciently kept up in England by the use of black vestments and muffled psalms.

INTROIT.—Out of the mouths of very babes and sucklings hast Thou ordained strength because of Thine enemies. Ps. O Lord our Governor, how excellent is Thy Name in all the world, Thou that hast set Thy glory above the heavens. Glory be.

HYMNS.

MATTINS. { *Sanctorum meritis.*
Rex gloriose martyrum. D. H. p. 26, A. A. 194.
EVENSONG. *Rex gloriose martyrum.* Ditto.

THE SUNDAY AFTER CHRISTMAS-DAY.

The Collect.

[A. D. 1549.]

ALMIGHTY God, who hast given us thy only-begotten Son to take our nature upon him, and as at this time to be born of a pure Virgin; Grant that we being regenerate, and made thy children by adoption and grace, may daily be renewed by thy Holy Spirit; through the same our Lord Jesus Christ, who liveth and reigneth with thee and the same Spirit, ever one God, world without end. *Amen.*

SEXTA DIES A NATIVITATE DOMINI Salisbury Use.
SIVE DOMENICA FUERIT SIVE NON.

[OMNIPOTENS sempiternæ Deus, [Greg. in die Nat. Dom.] qui hunc diem per incarnationem Verbi tui et partum beatæ Mariæ Virginis consecrasti, da populis tuis in hac celebritate consortium ut qui tua gratia sunt redempti, tua sint adoptione securi. Per eundem.]

Memoria de Nativitate: de Sancto Salisbury Use.
Stephano: de Sancto Johanne: de Innocentibus: et de Sancto Thoma.

	<i>Modern English.</i>	<i>Salisbury Use.</i>	<i>Modern Roman.</i>	<i>Eastern.</i>
EPISTLE.	Gal. iv. 1—7.	Gal. iv. 1—7.	Gal. iv. 1—7.	Gal. iii. 11—15.
GOSPEL ²	Matt. i. 18—25.	Luke ii. 33—40.	Luke ii. 33—40.	Matt. ii. 13—23.

THE CIRCUMCISION OF CHRIST.

The Collect.

[A. D. 1549.]

Luke ii. 21.
Gal. iv. 4.
Rom. ii. 29.
Col. ii. 10, 11.
iii. 5.
1 Pet. ii. 11, 21.
1 John ii. 15, 16.

ALMIGHTY God, who madest thy blessed Son to be circumcised, and obedient to the law for man; Grant us the true circumcision of the Spirit; that, our hearts, and all our members being mortified from all worldly and carnal lusts, we may in all things obey thy blessed will; through the same thy Son Jesus Christ our Lord. *Amen.*

DIES CIRCUMCISIONIS.

Salisbury Use.

[OMNIPOTENS Deus, cujus unigenitus hodierna die, ne legem solveret quam adimplere venerat, corporalem suscepit circumcisionem; spirituali circumcisione mentes vestras ab omnibus vitiorum incentivis expurget; et suam in vos infundet benedictionem. *Amen.*]

[Greg. Sacr. Benedict. in Oct. Dom.]

	<i>Modern English.</i>	<i>Salisbury Use.</i>	<i>Modern Roman.</i>	<i>Eastern.</i>
EPISTLE.	Rom. iv. 8—14.	Titus ii. 11—15.	Titus ii. 11—15.	Col. ii. 8—12.
GOSPEL.	Luke ii. 15—21.	Luke ii. 21.	Luke ii. 21.	Luke ii. 20, 21. 40—52.

THE SUNDAY AFTER CHRISTMAS.

The Lord's Day within the Octave of Christmas carries on, of necessity, the idea of the preceding festival, forming a kind of "Low Sunday" to Christmas Day itself. There is no change of Collect, but the Epistle and Gospel strike a new chord in the harmony of the Eucharistic Scriptures. On Christmas Day they memorialized the condescension of the Word of God in becoming Son of Man: on this day they set forth the exaltation of human Nature by that condescension. On the one day, the Son of God is shown to us becoming the Son of Man: on the other, the sons of men are shown to us becoming the sons of God, through the Adoption won for them by the Holy Child Jesus. We are "heirs of God through Christ," because of the fulfilment of the promise conveyed by His Name, "He shall save His people from their sins."

The genealogies were struck out of the Gospel of the Day by Bishop Cosin in 1661: and he proposed to insert a note at the end of the Gospel, "This Collect, Epistle, and Gospel, are to be used only till the Circumcision."

INTROIT.—For while all things were in quiet silence, and that night was in the midst of her swift course, Thine Almighty Word leaped down from Heaven out of Thy royal throne. Ps. The Lord is King, and hath put on glorious apparel: the Lord hath put on His apparel, and girded Himself with strength. Glory be.

THE CIRCUMCISION.

This day has been observed from the earliest ages of the Church as the Octave of the Nativity, and from about the sixth century as both the Octave of the Nativity and the Feast of the Circumcision. From its coincidence with the Kalends of January, on which the riotous and immoral festival of the Saturnalia was kept by the Romans, it offered a great difficulty to the Church for some centuries, and there were places and periods in which the Saturnalia were so mixed up with the Christian feast that the observance of the latter was altogether forbidden.

Of the Circumcision there is no notice whatever in the Comes of St. Jerome, the day being called Octava Domini, the Epistle being Gal. iii. 23, and the Gospel the same as ours. In St. Gregory's Sacramentary the name of the day is still the Octave

THE EPIPHANY, OR THE MANIFESTATION OF CHRIST TO THE GENTILES.

IN DIE EPIPHANLÆ,

The Collect.

Oratio.

Matt. ii. 1, 2, 7—11.
 Luke ii. 30—32.
 John xiv. 7, 9.
 11. xvii. 8.
 1 Cor. xiii. 12.
 Rev. xxii. 3, 4.

O GOD, who by the leading of a star didst manifest thy only-begotten Son to the Gentiles; Mercifully grant, that we, which know thee now by faith, may after this life have the fruition of thy glorious Godhead; through Jesus Christ our Lord. *Amen.*

DEUS, qui hodierna die unigeni-
 tum tuum gentibus, stella duce,
 revelasti; concede propitius, ut qui
 jam te ex fide cognovimus, usque ad
 contemplandum speciem tuæ celsitudinis perducamur. Per eundem.

Salisbury Use.
 Greg. in Epiph.

	<i>Modern English.</i>	<i>Salisbury Use.</i>	<i>Modern Roman.</i>	<i>Eastern.</i>
EPISTLE.	Eph. iii. 1—12.	Isa. lx. 1—6.	Isa. lx. 1—9.	Titus ii. 11—14. iii. 4—7.
GOSPEL.	Matt. ii. 1—12.	Matt. ii. 1—12.	Matt. ii. 1—12.	Matt. iii. 13—17.

of the Lord, and the Circumcision is not noticed in the Collect; but in the proper Preface are the words, "per Christum Dominum nostrum: cujus hodie Circumcisionis diem, et Nativitatis octavam celebrantes;" and the words of the Benediction, as printed above, are equally explicit. In the Salisbury Missal the day is named as it now is in the Prayer Book, but except in the Gospel there is not the slightest allusion to the festival as being connected with the Circumcision. In modern times, the tendency has been to observe the day as New Year's Day, overlooking, as far as possible, its connexion with the Nativity, as well as with the Circumcision.

The true idea of the day seems to be, that it belongs to Christmas as its Octave, but that as the three days after Christmas are specially honoured by the Commemoration of Saints, so the Octave is supplemented with the Commemoration of our Lord's Circumcision, to do still greater honour to the day of His Nativity. The two are pleaded conjointly in the Litany, "By Thy holy Nativity and Circumcision."

The Rubric at the end of the Gospel was inserted by Bishop Cosin. It varies in a very important particular from the previous Rubric of 1552.

1552.

If there be a Sunday between the Epiphany and the Circumcision: then shall be used the same Collect, Epistle, and Gospel, at the Communion, which was used upon the day of Circumcision.

1661.

The same Collect, Epistle, and Gospel, shall serve for every day after unto the Epiphany.

In the Scottish Prayer Book of 1637 the Rubric stood as in that of 1552, with the addition, "So likewise, upon every other day from the time of the Circumcision to the Epiphany." Either daily celebration of the Holy Communion was not contemplated in 1552, or the omission of any mention of it in this Rubric was an oversight. In 1637 and 1661 it was clearly provided for.

January 1st was never in any way connected with the opening of the Christian year; and the religious observance of this day has never received any sanction from the Church, except as the Octave of Christmas and the Feast of the Circumcision. The spiritual "point" of the season all gathers about Christmas: and as the modern New Year's Day is merely conventionally so (New Year's Day being on March 25th until a hundred and ten years ago), there is no reason why it should be allowed at all to dim the lustre of a day so important to all persons and all ages as Christmas Day. We ought also to guard against a Judaical tendency even in the observance of the Circumcision itself.

INTROIT.—Unto us a Child is born, unto us a Son is given, and the government shall be upon His shoulder; and His name

shall be called Wonderful. Ps. Sing unto the Lord a new song, for He hath done marvellous things. Glory Be.

HYMNS.

EVENSONG and MATTINS.—*A solis ortus cardine.* H. N. 14. 34.
 MATTINS.—*Christe Redemptor omnium.* H. N. 13. 33, H. A. M. 45, C. H. 21.

These hymns are appointed to be sung daily up to the Epiphany, except on the octaves of SS. Stephen and John and of the Holy Innocents, when the same hymns are appointed as on those festivals.

THE EPIPHANY.

In its earliest origin, the Epiphany was observed as a phase of Christmas in the same way as the Circumcision is now to be so regarded: and the intimate association of the two is still marked by the custom of the Armenian Christians, who always keep their Christmas on the 6th of January, instead of the 25th of December. The idea on which the whole cycle of the Festivals of our Lord is founded is that of memorializing before God the successive leading points of our Lord's life and acts: and the order in which the Holy Days have been observed is also that in which these leading points are pleaded in two clauses of the Litany:—"By the mystery of Thy holy Incarnation; by Thy holy Nativity and Circumcision; by Thy Baptism, Fasting, and Temptation. By Thine Agony and bloody Sweat; by Thy Cross and Passion; by Thy precious Death and Burial; by Thy glorious Resurrection and Ascension; and by the coming of the Holy Ghost, Good Lord, deliver us." Hence the Epiphany was originally regarded as that part of the Christmas Festival on which was commemorated the Baptism of the Lord Jesus by St. John the Baptist. It seems to have acquired a more independent position, and to have begun to be observed in memory of our Lord's Manifestation to the Gentile Magi, about the fourth century and in the Western Church: but probably this was never more than a development of the original idea; and although it may have become the most prominent feature of the festival at particular periods, it never superseded the original one altogether. The primitive name of the day was Theophany, and this is still retained in the Oriental Church. Both *Theophania* and *Epiphania* are used in the Comes of St. Jerome, and as late as the Sacramentary of St. Gregory: but the former name seems to have dropped out of use about the same time that the festival began to be connected with the Adoration of the Magi. Even St. Jerome himself calls it "Epiphaniarum dies" in his Commentary on Ezekiel, and speaks of it as "venerabilis." Durandus says, that "in codicibus antiquis hæc dies Epiphaniarum pluraliter intitulatur, et ideo tripliciter nominatur, scilicet Epiphania, Theophania, et Bethphania:" the third name being associated with our Lord's Manifestation in the house at the Marriage in

THE FIRST SUNDAY AFTER THE
EPIPHANY.*The Collect.*Ps. vi. 9.
1 John v. 14.
Ps. xxxii. 8.
Col. i. 9-11.
Heb. xii. 23. xiii.
20, 21.

O LORD, we beseech thee mercifully to receive the prayers of thy people which call upon thee; and

DOMINICA I., POST OCTAV. EPIPHANIÆ,
AD MISSAM.*Oratio.*

VOTA, quæsumus, Domine, supplicantis populi cœlesti pietate prosequere; ut et quæ agenda sunt,

Salisbury Usa.
Greg. i. post
Theophan.

Cana. The latter name appears to have been little used, but the idea it represents is illustrated by the Gospel for the Second Sunday after Epiphany, and by the Second Lesson at Evensong on the Festival itself. In the Eastern Church the Theophany is also called *The Lights*, "from the array," Dr. Neale says, "of torches and tapers with which the Benediction of the Waters is performed on this day, as they symbolize that spiritual illumination to which our Lord, by His Baptism in Jordan, consecrated water." If this name of the festival is ancient (and it seems to be as old as Gregory Nazianzen's time), one might expect to find that it originated in the illumination of the world by that "true Light, which, coming into the world, enlighteneth every man," and to which the Magi were led by the light of the Star.

There is a beautiful and very instructive unity about the Scriptures used on the Epiphany. The first morning Lesson is the 60th chapter of Isaiah, the same which accidentally occurs on Christmas Eve: "Arise, shine; for thy Light is come, and the glory of the Lord is risen upon thee . . . the Lord shall be unto thee an everlasting Light, and thy God thy glory . . . the Lord shall be thine everlasting Light, and the days of thy mourning shall be ended." The same chapter also contains the prophecy which began to be fulfilled by the adoration of the Magi as told in the Gospel of the Day, "And the Gentiles shall come to thy Light, and kings to the brightness of thy rising:" and the Epistle reads like an expansion of this verse, showing how the Light of Christ is manifested to the world at large, in and by the Church. The first Lesson is the ancient Epistle of the Church, as is shown by St. Jerome's Lectionary, but the Gospel was the same as our own.

In the second morning Lesson (a week-day Gospel of the season, in the Comes) we have the original idea of the Festival, the Theophany or manifestation of our Lord's Divine Sonship at His Baptism by the Voice from Heaven and the visible descent of the Holy Ghost. The First Lesson at Evensong sets forth the joy of the Church and the glory that was to come upon it through the coming of her Light: "Sing, O heavens; and be joyful, O Earth; and break forth into singing, O mountains; for the Lord hath comforted His people, and will have mercy upon His afflicted . . . I will lift up Mine hand to the Gentiles, and set up My standard to the people, and they shall bring thy sons in their arms, and thy daughters shall be carried upon their shoulders. And kings shall be thy nursing fathers, and their queens thy nursing mothers . . ." The Bethphany, or manifestation of our Lord's Divine power at the marriage by turning water into wine [see Gospel for Second Sunday], is illustrated by the Second Lesson at Evensong.

Thus each phase of this great festival is presented to us on the day itself; and as will afterwards be shown, the subsequent Sundays have a definite and systematic relation to the festival after which they are named.

Some authors have suggested, and it seems not improbable, that the "star" which appeared to the Wise Men in the East might be that glorious light which shone upon the shepherds of Bethlehem when the angel came to give them the glad tidings of our Saviour's birth. At a distance this might appear like a star; or, at least, after it had thus shone upon the shepherds, might be lifted up on high, and then formed into the likeness of a star. According to an ancient commentary on St. Matthew, this star, on its first appearance to the Magi, had the form of a radiant child bearing a sceptre or cross; and in some early Italian frescoes it is so depicted.

It has always been the tradition that the Magi were three in

number, and that the remainder of their lives after the events recorded in the Gospel was spent in the service of God. They are said to have been baptized by St. Thomas, to have themselves preached the Gospel, and to have been crowned with martyrdom in confirmation of its truth. Their relics are believed to be preserved at Cologne, and are exhibited in the Cathedral there, in a costly shrine of silver-gilt, enriched with gems of great value. Their names are there given as Gaspar, Melchior, and Balthazar, and these names are ascribed to the Magi in mediæval art and literature.

In England a striking memorial of their offering is kept up by our Sovereigns, who make an oblation of gold, frankincense, and myrrh at the altar of the Chapel Royal in the Palace of St. James on this festival. Until recently the ceremony was performed in person. The king coming from his closet, attended as usual, proceeded to the Altar at the time of the Offertory, and knelt down there, when the Dean or Sub-dean of the Chapels Royal received into a golden basin the offerings of gold, frankincense, and myrrh from the king's hands, and offered them upon the altar. The offering is now made by an officer of the royal household; but we may venture to hope that the striking significance and humility by which it is characterized will cause it to be revived in the original form at some future day.

The Epiphany is a festival which has always been celebrated with great ceremony throughout the whole Church: its threefold meaning, and its close association with the Nativity as the end of Christmas-tide, making it a kind of accumulative festival. And such a celebration of it is to be desired: for it will help to give us true reverence for the Babe of Bethlehem by eucharistic, ritual, homiletic, and mental recognition of His Divine Glory. When we are entering with our Lord on the course of His earthly humiliation, it is fitting that we should make such a recognition of His Divinity: and as the Transfiguration trained the three chosen Apostles for the sight of the Agony and the Crucifixion, so the Epiphany will set the Church forward in a true spirit towards the observance of Lent and Good Friday.

[Bishop Cosin proposed the insertion of a rubric;—"And the same Collect, Epistle, and Gospel shall serve till the Sunday next following." He also erased "to the Gentiles" in the title of the day.]

INTROIT.—Behold, the Lord our Ruler is come [Dominator dominus. Cf. Mal. iii. 1], and His Kingdom is in His hand, and power and dominion are His. Ps. Give the king thy judgments, O Lord, and Thy righteousness unto the king's son. Glory be.

HYMNS.

EVENSONG.—*Hostis Herodes impie.* H. N. 17. 42.MATTINS.—*A Patre Unigenitus.* A. A. 181, D. H. p. 33.

These hymns are appointed to be sung daily throughout the Octave.

THE FIRST SUNDAY AFTER THE EPIPHANY.

This Sunday commemorates the manifestation of our Lord's glory for the second time in the Temple. In His infancy that glory had been revealed to the faithful souls who waited for the loving-kindness of the Lord in the midst of His Temple, and they had seen the Epiphany of that Sun of Righteousness whose Light was to lighten the Gentiles, and to be the glory of God's people Israel. Twelve years afterwards the childhood of the Holy Child Jesus was to reveal the same glory to all who had faith to behold it, during that visit to the Temple when He sat among the doctors and fulfilled the words, "I have more understanding than

grant that they may both perceive and know what things they ought to do, and also may have grace and power faithfully to fulfil the same; through Jesus Christ our Lord. *Amen.*

videant; et ad implenda quæ viderint, convalescant. Per.

	<i>Modern English.</i>	<i>Salisbury Use.</i>	<i>Modern Roman.</i>	<i>Eastern.</i>
EPISTLE.	Rom. xii. 1—5.	Rom. xii. 1—5.	Rom. xii. 1—5.	Eph. iv. 7—13.
GOSPEL.	Luke ii. 41—52.	Luke ii. 41—52.	Luke ii. 42—52.	Matt. iv. 18—23.

THE SECOND SUNDAY AFTER THE EPIPHANY.

The Collect.

Ps. xxii. 28.
2 Chron. vi. 21.
John xiv. 27.
Phil. iv. 6, 7.

ALMIGHTY and everlasting God, who dost govern all things in heaven and earth; Mercifully hear the supplications of thy people, and grant us thy peace all the days of our life; through Jesus Christ our Lord. *Amen.*

DOMINICA II., POST OCTAV. EPIPHANIE.

Oratio.

OMNIPOTENS sempiternæ Deus, qui cœlestia simul et terrena moderaris, supplicationes populi tui clementer exaudi, et pacem tuam nostris concede temporibus. Per Dominum.

Salisbury Use.
Greg. Dom. ii.
post Theoph.

	<i>Modern English.</i>	<i>Salisbury Use.</i>	<i>Modern Roman.</i>	<i>Eastern.</i>
EPISTLE.	Rom. xii. 6—16.	Rom. xii. 6—16.	Rom. xii. 6—16.	
GOSPEL.	John ii. 1—11.	John ii. 1—11.	John ii. 1—11.	

My teachers." Among those teachers may have been Nicodemus and Gamaliel, and the rays which were shed from the Light of the Divine understanding at which they marvelled, may have fallen on their minds with a vivifying power which afterwards made the one fit to receive the first full revelation of the truth respecting new birth into Christ, and the other to be the teacher of St. Paul, by whom the Light of Christ was so marvellously spread abroad among the Gentiles.

INTROIT.—I beheld the Son of Man sitting upon a throne high and lifted up, and a multitude of the heavenly host worshipped Him, singing with one voice, Behold Him, the Majesty ['numen; the Roman Use has 'nomen'] of whose dominion is for ever and ever. Ps. O be joyful in the Lord, all ye lands: serve the Lord with gladness. Glory be.

HYMNS.

From the morrow of the Octave of the Epiphany to the first Sunday in Lent, the Ordinary Hymns were sung, as follows:—

Sunday.	MATTINS. <i>Primo dierum omnium.</i> H. N. 3. 5, H. A. M. 21.
	LAUDS. <i>Æternæ rerum Conditor.</i>
	EVENSONG. <i>Lucis Creator optime.</i> H. N. 8. 11, H. A. M. 24.
Monday.	COMPLINE. <i>Salvator mundi, Domine.</i> H. A. M. 49, C. H. 24.
	MATTINS. <i>Somno reffectis artubus.</i>
	LAUDS. <i>Splendor Paternæ gloriæ.</i> H. N. 54. 17, H. A. M. 3.
Tuesday.	EVENSONG. <i>Immense cœli Conditor.</i> H. N. 55. 18.
	MATTINS. <i>Consortium Paterni Luminis.</i>
	LAUDS. <i>Alis diei nuntius.</i> H. N. 56. 19.
	EVENSONG. <i>Telluris ingens Conditor.</i> H. N. 57. 20.

Wednesday.	MATTINS. <i>Rerum Creator optime.</i>
	LAUDS. <i>Nox et tenebræ et nubila.</i> H. N. 58. 21.
Thursday.	EVENSONG. <i>Cœli Deus Sanctissime.</i> H. N. 59. 22.
	MATTINS. <i>Nox atra rerum contegit.</i>
	LAUDS. <i>Lux ecce surgit aurea.</i> H. N. 60. 23.
Friday.	EVENSONG. <i>Magnæ Deus potentia.</i> H. N. 61. 24.
	MATTINS. <i>Tu Trinitatis Unitas.</i>
	LAUDS. <i>Æterna cœli gloria.</i> H. N. 62. 25.
Saturday.	EVENSONG. <i>Plasmator hominis Deus.</i> H. N. 63. 26.
	MATTINS. <i>Summæ Deus clementia.</i>
	LAUDS. <i>Aurora jam spargit polum.</i> H. N. 64. 27.
	EVENSONG. <i>Deus Creator omnium.</i> D. H. p. clxviii. A. A. 115.

THE SECOND SUNDAY AFTER THE EPIPHANY.

On this day is commemorated that beginning of Miracles by which "Jesus manifested forth His glory," so that "His disciples believed on Him." The transmutation of water into wine revealed our Lord as possessing the power of a Creator; and showed that it was He Who had once taken of the dust of the earth and elevated it in the order of existence, so that by His breathing it became a living man. This, therefore, is the Epiphany of Jesus as the Lord of a New Creation, by which His former work is to be exalted to a much higher place and function in the dispensation of His Providence: and in the act which is recorded He prefigured that work of re-creation which He now causes to be wrought in His Kingdom for the salvation of souls and bodies. Simple elements pass silently beneath the power of His blessing: His servants bear forth: water becomes generous wine. So Baptism exalts the souls and bodies of men from the Kingdom of Nature to the Kingdom of Grace, and the Holy Eucharist is the means

THE THIRD SUNDAY AFTER THE
EPIPHANY.*The Collect.*

Heb. iv. 15, 16.
Rom. viii. 26.
Ps. lx. 5, 11.
xxxviii. 39, 40.

ALMIGHTY and everlasting God, mercifully look upon our infirmities, and in all our dangers and necessities stretch forth thy right hand to help and defend us; through Jesus Christ our Lord. *Amen.*

DOMINICA III., POST OCTAV.
EPIPHANIE.*Oratio.*

OMNIPOTENS sempiterne Deus, infirmitatem nostram propitius respice, atque ad protegendum nos dexteram tuæ majestatis extende. Per Dominum.

Salisbury Use.
Greg. Dom. iii.
post Theoph.

	<i>Modern English.</i>	<i>Salisbury Use.</i>	<i>Modern Roman.</i>	<i>Eastern.</i>
EPISTLE.	Rom. xii. 16—21.	Rom. xii. 16—21.	Rom. xii. 16—21.	
GOSPEL.	Matt. viii. 1—13.	Matt. viii. 1—13.	Matt. viii. 1—15.	

THE FOURTH SUNDAY AFTER THE
EPIPHANY.*The Collect.*

1 John v. 19.
2 Pet. iii. 17.
Matt. xxvi. 41.
1 Cor. x. 13.
2 Cor. xii. 9.

O GOD, who knowest us to be set in the midst of so many and great dangers, that by reason of the frailty of our nature we cannot always stand upright; Grant to us such strength and protection as may support us in all dangers, and carry us through all temptations; through Jesus Christ our Lord. *Amen.*

DOMINICA IV., POST OCTAV.
EPIPHANIE.*Oratio.*

DEUS qui nos in tantis periculis constitutos, pro humana scis fragilitate non posse subsistere: da nobis salutem mentis et corporis, ut ea quæ pro peccatis nostris patimur, te adjuvante vincamus. Per Dominum nostrum.

Salisbury Use.
Greg. Dom. iv.
post Theoph.

	<i>Modern English.</i>	<i>Salisbury Use.</i>	<i>Modern Roman.</i>	<i>Eastern.</i>
EPISTLE.	Rom. xiii. 1—7.	Rom. xiii. 8—10.	Rom. xiii. 8—10.	
GOSPEL.	Matt. viii. 23—34.	Matt. viii. 23—27.	Matt. viii. 23—27	

by which our whole nature is built up into the nature of Christ, elevated from one step to another, "changed from glory to glory."

Thus at a marriage supper was revealed the great truth of that Union between the Lamb of God and the Bride by which the virtue of the Incarnation of the Word is extended to fallen human nature. And thus also are we taught, that in the Miracle which is being continually wrought by the elevation of lowly elements into sacramental substances, and by the regeneration and edification of souls through their operation, Christ is still "manifesting forth His glory" in every generation, and giving cause for His disciples to believe in Him.

INTROIT.—For all the world shall worship Thee, sing of Thee, and praise Thy Name, O Thou most highest. Ps. O be joyful in God, all ye lands; sing praises unto the honour of His Name, make His praise to be glorious. Glory be.

THE THIRD SUNDAY AFTER THE EPIPHANY.

The Epiphany of Christ as the Divine Healer of human infirmities is commemorated on this Sunday. His all-embracing sympathy could take in even the leper and the stranger; and would manifest itself to overflowing by touching the one, whom no one else would come near, and by healing the servant of the other, though he was the Gentile slave of a Gentile centurion. The glory of the Good Physician was thus manifested forth, immediately after He had made His Mission openly known to the people, in two remarkable instances. Leprosy was a disease for which no human physician could find a cure: yet Christ put

forth His hand and touched the leper, and at once a regeneration of the diseased nature took place, so that he became a new man. Palsy or paralysis, again, is a loss of all muscular energy and power, so that the afflicted person becomes, in a greater or less degree, incapable of moving; and his body, in severe cases, is, in one sense, dead. Very rarely indeed is paralysis cured; and never, in the case of one "grievously tormented" with it, as this slave was. Yet the will of the Good Physician effected the cure in a moment, either by the ministration of one to whom He could say, "Go, and he goeth" on his Master's errand of mercy, or else by the immediate operation of His Divine Omnipotence.

As Jesus manifested forth His glory by displaying His Power over the inanimate Creation when He transubstantiated the water into wine, so now He showed it by changing a Leper and a Paralytic into sound and whole men by His touch and His will.

The ancient Offertory sentence brought out this doctrine very beautifully. It was, "The right hand of the Lord hath the pre-eminence: the right hand of the Lord bringeth mighty things to pass. I shall not die but live, and declare the works of the Lord." The same idea forms the basis of the Collect.

INTROIT.—Worship the Lord, all ye His angels. Sion heard of it and rejoiced; the daughters of Judah were glad. Ps. The Lord is King, the earth may be glad thereof, yea, the multitude of the isles may be glad thereof. Glory be.

THE FOURTH SUNDAY AFTER THE EPIPHANY.

Our Lord Jesus is on this Sunday commemorated as the Saviour of all from every danger, as well as the Saviour of the

THE FIFTH SUNDAY AFTER THE EPIPHANY.

The Collect.

Isa. xxvii. 3.
Heb. xiii. 9.
Prov. iii. 5.
1 John iv. 4.
Isa. xxvi. 1. 4.

O LORD, we beseech thee to keep thy Church and household continually in thy true religion; that they who do lean only upon the hope of thy heavenly grace may evermore be defended by thy mighty power; through Jesus Christ our Lord. *Amen.*

DOMINICA V., POST OCTAV. EPIPHANIE.

Oratio.

FAMILIAM tuam, quæsumus, Domine, continua pietate custodi; ut quæ in sola spe gratiæ cœlestis ininititur, tua semper protectione muniat. Per Dominum.

Salisbury Use.
Greg. Dom. v.
post Theoph.

	<i>Modern English.</i>	<i>Salisbury Use.</i>	<i>Modern Roman.</i>	<i>Eastern.</i>
EPISTLE.	Col. iii. 12—17.	Col. iii. 12—17.	Col. iii. 12—17.	
GOSPEL.	Matt. xiii. 24—30.	Matt. xiii. 24—30.	Matt. xiii. 24—30.	

THE SIXTH SUNDAY AFTER THE EPIPHANY.

The Collect.

[A. D. 1661.]
1 John xiii. 8.
John i. 12, 13.
Rom. viii. 17.
1 John iii. 2, 3.
Matt. xxiv. 30.
Phil. iii. 21.
Heb. i. 8.

O GOD, whose blessed Son was manifested that he might destroy the works of the devil, and make us the sons of God, and heirs of eternal

[DOMINICA SEXTA POST THEOPHANIAM.] [Greg. Sacr.]

DEUS, qui ad æternam vitam in Christi Resurrectione nos reparas, imple pietatis tuæ ineffabile sacramentum, ut, cum in Majestate sua

[Greg. 'Alliæ
Orationes Pas-
chales,' ix.]

diseased and infirm from the bodily afflictions which happen to human nature. It is not now a Leper or a Paralytic, but strong and hale men who are in need of His help. And yet, though no horrible or painful disease afflicts them, they could not be in any more hopeless or helpless condition than when at sea in an open boat at the mercy of a tempest. He was, doubtless, revealing to them the true source of their safety.—His Presence, which makes an Ark of the Church. He was asleep, and they had little faith, and the storm was violent; and the ship being "covered with the waves," we may well suppose that the danger was, from a human point of view, extreme. Christ reveals to the Apostles that the human point of view takes in a very small part of the whole prospect by manifesting forth His authority over the winds and the waves, and showing them that His Presence could preserve them, because it is the Presence of God.

The miracle of casting out the devils from the two possessed Gergesenes, carries on the parabolical teaching of the storm and its subjugation, by showing that the power of Christ extends not only over natural elements and forces, but over supernatural beings. And hence the Lord of the Church is continually declaring to us, that though it may be tempest-tossed on the waves of the world, He can ensure its safety; and that though evil spirits oppose it with all the array of their power, yet "the gates of Hell shall not prevail against it."

The Epistle for this Sunday was altered in 1549, because it coincided with that for the first Sunday in Advent. In the Mozarabic rite it is taken from Rom. vii., which, as it is respecting the struggle of our two natures, seems once to have been co-existent with our Collect.

INTROIT.—Worship the Lord, all ye His angels. Sion heard of it and rejoiced; the daughters of Judah were glad. Ps. The Lord is King, the earth may be glad thereof, yea, the multitude of the isles may be glad thereof. Glory be.

THE FIFTH SUNDAY AFTER THE EPIPHANY.

The connexion of this Sunday with the Epiphany season is not made so clear in the Gospel of the Tares and the Wheat, as in that of those the Gospels of which record the Manifestation of the glory of Christ in His acts. Yet it reveals Him as the Lord of the Church for its government as well as for its preservation; and

shows that even when He seems to be suffering evil that might be prevented, His purpose is still full of love for His own, lest the wheat should be injured by the destruction of the tares. And as, moreover, our Lord Himself has explained that the seed is the Word of God, that is, His own Person, this Gospel and Sunday must be regarded as setting forth the glory of Christ in the increase of His Church, and the development of that Kingdom on earth which is to form so large a portion of the Eternal dominion of the King of kings. It shows also the ultimate triumph of the Word in the face of all opposition. Men may sleep who should have guarded the field, and the enemy may seem to have gained an advantage by which the glory of the Word is dimmed; but God waits His time, and when that is fulfilled sends forth His servants to undo the work of the Evil One; so that the glory of the Redeemer is manifested by the gathering in of a large harvest of the redeemed into His heavenly garner.

The Epistle for this Sunday takes up the course of St. Paul's Epistles from the 24th Sunday after Trinity, and both Gospel and Epistle have a relation to the season of Advent, because they used frequently to be required to complete that of Trinity.

INTROIT.—Worship the Lord, all ye His angels. Sion heard of it and rejoiced; the daughters of Judah were glad. Ps. The Lord is King, the earth may be glad thereof, yea, the multitude of the isles may be glad thereof. Glory be.

THE SIXTH SUNDAY AFTER THE EPIPHANY.

From 1549 until 1661 the Church of England reckoned only five Sundays after Epiphany, and if a sixth occurred before Septuagesima, the Collect, Epistle, and Gospel of the Fifth were repeated. The old rubric was, "The sixth Sunday (if there be so many) shall have the Collect, Epistle, and Gospel that was upon the Fifth Sunday." To this it was at first proposed to add, "And if there be fewer Sundays than six, yet this Collect, Epistle, and Gospel of the Fifth Sunday shall be last:" but this new rubric (inserted in the Durham book) was erased, and a sixth Sunday added without it¹.

¹ The ancient English use was to reckon one Sunday within the Octave of Epiphany, and five Sundays "after the Octave."

Rom. ix. 36.
Rev. xix. 6.

life; Grant us, we beseech thee, that, having this hope, we may purify ourselves, even as he is pure; that, when he shall appear again with power and great glory, we may be made like unto him in his eternal and glorious kingdom; where with thee, O Father, and thee, O Holy Ghost, he liveth and reigneth, ever one God, world without end. *Amen.*

Salvator noster advenerit, quos fecisti baptismo regenerari, facias beata immortalitate vestiri. Per eundem.]

	<i>Modern English.</i>	<i>Salisbury Use.</i>	<i>Modern Roman.</i>	<i>Eastern.</i>
EPISTLE.	1 John iii. 1—8.		1 Thess. i. 2—10.	2 Tim. iii. 10—15.
GOSPEL.	Matt. xxiv. 23—31.		Matt. xiii. 31—35.	Luke xviii. 10—14.

THE SUNDAY CALLED SEPTUAGESIMA,
OR THE THIRD SUNDAY BEFORE
LENT.

The Collect.

Ps. lxxix. 16.
Ezra ix. 13.
Ps. xxv. 7. cxv.
1.
Eph. iii. 21.

O LORD, we beseech thee favourably to hear the prayers of thy people; that we, who are justly punished for our offences, may be mercifully delivered by thy goodness, for the glory of thy Name; through Jesus Christ our Saviour, who liveth and reigneth with thee and the Holy Ghost, ever one God, world without end. *Amen.*

DOMINICA IN SEPTUAGESIMA.

Oratio.

PRECES populi tui, quæsumus, Domine, clementer exaudi, ut qui juste pro peccatis nostris affligimur, pro tui nominis gloria misericorditer liberemur. Per Dominum nostrum Jesum Christum Filium tuum. Qui tecum vivit et regnat.

Salisbury Use.
Greg. in LXX.
Super populum.

	<i>Modern English.</i>	<i>Salisbury Use.</i>	<i>Modern Roman.</i>	<i>Eastern.</i>
EPISTLE.	1 Cor. ix. 24—27.	1 Cor. ix. 24—27. x. 1—4.	1 Cor. ix. 24—27. x. 1—5.	1 Cor. vi. 12—20.
GOSPEL.	Matt. xx. 1—16.	Matt. xx. 1—16.	Matt. xx. 1—16.	Luke xv. 11—32.

The Collect is written in the margin of the Durham book, and appears to be an original composition of Bishop Cosin's; though there is some similarity of expression between it and the above Easter Collect of St. Gregory's Sacramentary, which seems to indicate that the one was in part suggested by the other¹.

The Epistle is most aptly chosen as a link between the Epiphany Sundays and those near Advent, the whole Service of this day being often required for the Twenty-fifth or Twenty-sixth Sunday after Trinity. The Collect is founded on the Epistle, and the Gospel displays the final Manifestation of the glory of Christ in the triumph of His Second Coming. Thus this day falls in with the old system of Epiphany Sundays, and forms an admirable climax to the whole series; while, at the same time, it is strikingly adapted for transfer to the end of the Trinity Season (if required), according to the anciently received practice of our own and other branches of the Western Church.

[There is of course no Introit for this day in the Salisbury Use. In the Roman it is the same as on the preceding Sunday; and the words are appropriate whether for Epiphany or before Advent.]

¹ The Collect of St. Gregory is copied from Bishop Cosin's own copy of the Sacramentary, Menard's edition of 1642.

SEPTUAGESIMA SUNDAY.

After the conclusion of the season of Epiphany the Sundays are reckoned with reference to Easter and its preceding fast. The origin of the names which distinguish the three Sundays before Lent cannot be historically accounted for, and has received various explanations in ancient and modern times. Pamelius considers that Septuagesima was so called in commemoration of the seventy years' captivity of Israel in Babylon, and that the other two Sundays following were named from it by analogy. As it was so much the habit of early Christian writers to compare the forty days' fast of Lent with the forty years' sojourn in the wilderness, this derivation seems a probable one. But the more generally received one in modern times is, that the fast of Lent being called Quadragesima, and that name being especially applied to the first Sunday in Lent, these three preceding Sundays were named from analogy, and as representing in round numbers the days which occur between each and Easter. Septuagesima is, indeed, only sixty-three days distant from Easter, but Quinquagesima is forty-nine; and the nearly correct character of the appellation in the latter case seems to support this theory. The second and more exact titles which were added to the old names of these Sundays in 1661 appear for the first

THE SUNDAY CALLED SEXAGESIMA, OR THE SECOND SUNDAY BEFORE LENT.

*The Collect.*Ps. xli. s. iii. 7.
8. lxxix. 17, 18.
Heb. vii. 25.

O LORD God, who seest that we put not our trust in any thing that we do; Mercifully grant that by thy power we may be defended against all adversity, through Jesus Christ our Lord. *Amen.*

DOMINICA IN SEXAGESIMA.

Oratio.

DEUS qui conspicias quia ex nulla nostra actione confidimus; concede propitius, ut contra omnia adversa Doctoris gentium protectione muniamur. Per.

Salisbury Use.
Greg. in LX.

1 Tim. ii. 7.

	<i>Modern English.</i>	<i>Salisbury Use.</i>	<i>Modern Roman.</i>	<i>Eastern.</i>
EPISTLE.	2 Cor. xi. 19—31.	2 Cor. xi. 19—33. xii. 9.	2 Cor. xi. 19. xii. 9.	1 Cor. viii. 8. ix. 2.
GOSPEL.	Luke viii. 4—15.	Luke viii. 4—15.	Luke viii. 4—15.	Matt. xxv. 31—46.

THE SUNDAY CALLED QUINQUAGESIMA, OR THE NEXT SUNDAY BEFORE LENT.

The Collect.

[A.D. 1549.]

1 Cor. xiii. 1—3.
Matt. xxii. 37—
40.
John xvii. 20, 21.

O LORD, who hast taught us that all our doings without charity are nothing worth; Send thy Holy

DOMINICA IN QUINQUAGESIMA.

[*Ad Completorium in die Pasche. Oratio.*]

SPIRITUM nobis, Domine, tuæ charitatis infunde, ut quos sacramentis paschalibus satiasti, tua facias

Salisbury Use.
Greg. Feria vi.,
intra L. quos
uno caelesti
pane satiasti.

time in Bishop Cosin's corrected Prayer Book. The ancient titles themselves are all three found in the Lectionary of St. Jerome, and in the Sacramentaries; but there are not any analogous ones in use in the Eastern Church.

The time and manner of observing Lent varied very much in the early Church, and these Sundays are a monument of this variation. Each of them marked the beginning of Lent in communities which extended it beyond forty days; and Durandus states that monastic persons were accustomed to begin the fast at Septuagesima, the Greeks at Sexagesima, and the secular clergy at Quinquagesima. It is very probable that the names themselves were adopted to mark another variation in the mode of keeping Lent. For in some parts of the Church fasting was not permitted on Sundays, Thursdays, or Saturdays, and yet the Lenten fast was to extend to forty days. The beginning of it was therefore thrown back to Septuagesima, the weeks from which day to Easter would include forty fasting-days. Other churches omitted only Thursdays and Sundays, and began the fast on Sexagesima. A third class made no omissions except of Sunday, and commenced their season of penitence two days before Ash-Wednesday, at Quinquagesima; while a fourth, perhaps the largest, limited Lent to thirty-six days, beginning it on Quadragesima Sunday¹.

When these various modes of keeping Lent had been all superseded under the reforming hand of St. Gregory the Great by our present custom, the Church still retained the penitential tone of the services for these three Sundays, and they thus form a link between the joyous seasons of Christmas and Epiphany, and the deeply sorrowful one which begins with Ash-Wednesday and reaches its climax in the Holy Week. Although some customs which were retained with this view in the ancient Church of England have been dropped in the modern,—such as the omission of the Alleluia at the beginning of Mattins,—the Scriptures of the season still mark it as one that leads up to Lent.

The Gospels and Epistles for the three Sundays are clearly appointed with a reference to Christian self-discipline; and they seem to have been chosen with the well-known ancient classification of virtues in view, as if to show the Christian application of the truths of heathen philosophy. Thus on Septuagesima the Epistle of the Christian strife for the mastery represents

Temperantia, the Gospel of the labourers and the penny a day, *Justitia*. On Sexagesima, *Fortitudo* is illustrated by St. Paul's account of his sufferings for Christ's sake, and *Honestas* by the Parable of the Sower, some of Whose good seed falls on honest and good hearts [*ἐν καρδίᾳ καλῇ καὶ ἀγαθῇ*]. Quinquagesima illustrates by the Epistle the Christian complement of all natural virtue in Charity; the climax of which was reached in the submission of the Son of Man to that contumely and persecution which He predicts in the Gospel of the day.

INTROIT.—The pains of hell came about me, and the snares of death overtook me. In my trouble, I called upon the Lord, and He heard me out of His holy temple. Ps. I will love Thee, O Lord my strength. The Lord is my strong rock, and my defence, and my Saviour. Glory be.

SEXAGESIMA SUNDAY.

On all three of the Sundays before Lent, the Apostle St. Paul is set forth as an illustrious example of self-denial, zeal, and suffering for Christ's sake; and on Quinquagesima his noble words as to the valuelessness of all such discipline and zeal without love, set the true Christian seal upon asceticism in every degree. It is with reference, no doubt, to this application of his example, that an allusion was made to the great Apostle of the Gentiles in the Collect; but the manner in which it was made led to its expulsion altogether in 1549; and to the insertion of the more reliable expression of being defended by the power of God. This day is marked "ad Sanctum Paulum" in the Comes.

INTROIT.—Up, Lord, why sleepest Thou: awake, and be not absent from us for ever. Wherefore hidest Thou Thy face: and forgettest our misery and trouble? For our soul is brought low, even unto the dust: our belly cleaveth unto the ground. Arise and help us: and deliver us for Thy Name's sake. Ps. We have heard with our ears, O God, our fathers have told us. Glory be.

QUINQUAGESIMA SUNDAY.

The ancient Collect for this day had a special reference to the practice of Confession on the Tuesday following, which was hence called Shrove Tuesday. It was as follows: "Preces nostras, quæsumus, Domine, clementer exaudi: atque peccatorum vinculis absolutos ab omni nos adversitate custodi. Per Dominum nostrum." Our present very beautiful Collect was substituted in 1549; it is formed on the basis of the Epistle, and is evidently

¹ So it still is in the Ambrosian rite: and so it was in the Mozarabic until the time of Cardinal Ximenes.

Eph. iv. 3.
Col. iii. 14.
1 John iii. 14.
Rev. iii. 1.

Ghost, and pour into our hearts that most excellent gift of charity, the very bond of peace and of all virtues, without which whosoever liveth is counted dead before thee: Grant this for thine only Son Jesus Christ's sake. *Amen.*

pietate concordet. Per Dominum. In unitate.]

	<i>Modern English.</i>	<i>Salisbury Use.</i>	<i>Modern Roman.</i>	<i>Eastern.</i>
EPISTLE.	1 Cor. xiii. 1—13.	1 Cor. xiii. 1—13.	1 Cor. xiii. 1—13.	Rom. xiii. 11. xiv. 4.
GOSPEL.	Luke xviii. 31—43.	Luke xviii. 31—43.	Luke xviii. 31—43.	Matt. vi. 14—21.

constructed also as a prayer for that Love without which the discipline of Lent would be unavailing.

At the end of the Gospel for Quinquagesima Sunday the following rubric is inserted in MS. in Cosin's Durham Prayer Book: "This Collect, Epistle, and Gospel shall serve only till the Wednesday following."

INTRORIT.—Be Thou my strong rock, and house of defence; that Thou mayest save me. For Thou art my strong rock and my castle: be Thou also my guide, and lead me for Thy Name's sake. Ps. In Thee, O Lord, have I put my trust: let me never be put to confusion; deliver me in Thy righteousness. Glory be.

LENT.

A Fast before Easter has been observed from the earliest Christian times; but the period of its duration varied in different countries and ages down to the seventh century. Of these variations Irenæus wrote in his Epistle to Victor, Bishop of Rome, about the close of the second century, when (speaking of the varying rules about Easter) he says, "For the difference of opinion is not about the day alone, but about the manner of fasting; for some think they are to fast one day, some two, some more: some measure their day as forty hours of the day and night." [Iren. in Euseb. v. 24.]

It is left uncertain, by the words of Irenæus, whether this universal primitive Lent of which he writes ever extended to forty days: and his words read differently in the several ancient texts of Eusebius. In some copies they are, as above, *οἱ δὲ τεσσαράκοντα ἡμέρας ἡμερῶν καὶ νυκτερινῶν συμμετροῦσι τὴν ἡμέραν αὐτῶν*: but in others, and in Rufinus, they read, "For some think they are to fast one day, some two, some more, some forty days; and they measure their day by the hours of the day and night." Tertullian, a few years later, speaks of the practice of the Church as believed with certainty to be founded on that passage of the Gospel in which those days were appointed for fasting, during which the Bridegroom was taken away. This has been thought by some to point to the period of forty days during which our Lord was going through His Temptation in the wilderness; but it is far more probable that it refers to the time during which His Soul was separated from His Body. Some few years later still, however, towards the middle of the third century, Origen speaks of forty days being consecrated to fasting before Easter. [Hom. x. in Levit.] And at the Council of Nicæa this period was taken for granted, as if long in use.

But, however early the extension of the Lenten fast to forty days may have been, it is certain that they were reckoned in several different ways, though always immediately preceding Easter. By various Churches the forty days were distributed over periods of nine, eight, and seven weeks (that is, from Septuagesima, Sexagesima, or Quinquagesima to Easter), by the omission of Sundays, Thursdays, and Saturdays, of Sundays and Saturdays, or of Sundays alone, from the number of fasting-days [see Notes on Septuagesima]; and it would appear that

Lent was sometimes called by the three names now confined to the three Sundays preceding it as well as by the name of Quinquagesima, or *Τεσσαρακοστή*. St. Gregory the Great introduced our present mode of observance, or sanctioned it with his authority, at the end of the sixth century; excluding Sundays from the number of fasting-days, and making the thirty-six days thus left of the forty-two immediately preceding Easter into an exact forty by beginning the Fast on the Wednesday before Quinquagesima Sunday instead of on the Monday following it. This rule seems to have been very readily accepted in the Western Church; but the Eastern Lent [*Μεγάλη Νηστεία*] begins on the Monday after the day which we call Quinquagesima; and the rule of fasting is so strict, that although some slight relaxation of its rigour is allowed on Sundays and Saturdays, not even the former are wholly excluded from the number of fasting-days.

The primary object of the institution of a fast before Easter was doubtless that of perpetuating in the hearts of every generation of Christians the sorrow and mourning which the Apostles and Disciples felt during the time that the Bridegroom was taken away from them. This sorrow had, indeed, been turned into joy by the Resurrection, yet no Easter joys could ever erase from the mind of the Church the memory of those awful forty hours of blank and desolation which followed the last sufferings of her Lord; and she lives over year by year the time from the morning of Good Friday to the morning of Easter Day by a re-presentation of Christ evidently set forth, crucified among us [Gal. iii. 1]. This probably was the earliest idea of a fast before Easter. But it almost necessarily followed that sorrow concerning the death of Christ should be accompanied by sorrow concerning the cause of that Death; and hence the Lenten fast became a period of self-discipline; and was so, probably, from its first institution in Apostolic times. And, according to the literal habit which the early Church had of looking up to the Pattern of her Divine Master, the forty days of His fasting in the wilderness while He was undergoing Temptation, became the gauge of the servants' Lent, deriving still more force as an Example, from the typical prophecy of it which was so evident in the case of Moses and Elijah.

St. Chrysostom speaks of great strictness in fasting on the part of many in his day, such as is still found in the Eastern Church. "There are those," he says, "who rival one another in fasting, and show a marvellous emulation in it; some indeed, who spend two whole days without food; and others who, rejecting from their tables not only the use of wine, and of oil, but of every dish, and taking only bread and water, persevere in this practice during the whole of Lent." [Hom. iv. on Stat.] He also speaks in another homily of men being purified, in the days of Lent, by prayer and almsdeeds, by fasting, watching, tears, and confession of sins, showing that the severe Lents of later ages were only such as had been observed in the time of that great Father of the Church. The general mode of fasting seems to have been to abstain from food until after six o'clock in the afternoon, and even then not to partake of animal food or wine. Yet it may be doubted whether such a mode of life could have been continued

THE FIRST DAY OF LENT, COMMONLY CALLED ASH-WEDNESDAY.

The Collect.

[A.D. 1549.]
 Wisd. xi. 23—26.
 Ez. xxxiii. 14.
 Acts iii. 19, 26.
 Ps. li. 10, 17.
 Luke xviii. 13.
 2 Cor. vii. 10, 14.
 Ps. cxxx. 4, 7.
 2 Cor. v. 10.

ALMIGHTY and everlasting God, who hatest nothing that thou hast made, and dost forgive the sins of all them that are penitent; Create and make in us new and contrite hearts, that we worthily lamenting our sins, and acknowledging our wretchedness, may obtain of thee, the God of all mercy, perfect remission and forgiveness; through Jesus Christ our Lord. *Amen.*

¶ *This Collect is to be read every day in Lent, after the Collect appointed for the Day.*

FERIA IV., IN CAPITE JEJUNII.

Salisbury Use.

Benedictio Cinerum.

OMNIPOTENS sempiternæ Deus qui misereris omnium et nihil odisti eorum quæ fecisti dissimulans peccata hominum propter penitentiam

	<i>Modern English.</i>	<i>Salisbury Use.</i>	<i>Modern Roman.</i>	<i>Eastern.</i>
EPISTLE.	Joel ii. 12—17.	Joel ii. 12—19.	Joel ii. 12—19.	
GOSPEL.	Matt. vi. 16—21.	Matt. vi. 16—21.	Matt. vi. 16—21.	

day after day for six weeks by those whose duties called upon them for much physical exertion; and it is possible that we ought not to interpret so literally as this such allusions to the fasting of ordinary Christians as we meet with in early writings.

Lent was the principal time, in the early Church, for preparing the Catechumens for Baptism, and a large portion of St. Cyril's Catechetical Lectures were delivered at this season. There were also constant daily sermons at the services, as we see from expressions used by St. Chrysostom and other fathers. Public shows were more or less strictly forbidden; and works of charity were engaged in by all who could undertake them. It was a time when sinners were called upon to do outward penance as a sign of inward penitence, that they might be received back to Communion at Easter. Lent was, in fact, a season of humiliation, abstinence from pleasure, fasting, prayer, penitence, and general depression of tone on account of sin; and was marked, on every side, with the sombre tokens of mourning.

From this short account of the Lenten fast of primitive days, we may go on to consider briefly what should be the mode of observing it in modern times, so that the ancient and unchanging principles of the Catholic Church may be applied to the ever-varying habits of the world which those principles are intended to leaven. The Church of England has not expressly defined any rule on the subject of fasting, but in the Homilies on the subject has urged the example of the Early Church as if intending it to be followed with a considerable amount of strictness. The work that is set before most persons, in the Providence of God, at the present day, makes it quite impossible, however, for those who have to do it to fast every day for six weeks until evening, or even to take one meal only in the day. And the ordinary mode of living is so restrained among religious persons, that such a custom would soon reduce them to an invalid condition, in which they could not do their duty properly in the station of life to which God has called them, whether in the world or in the sanctuary. And although it may seem, at first, that men ought to be able to fast in the nineteenth century as strictly as they did in the sixteenth, the twelfth, or the third, yet it should be remembered that the continuous labour of life was unknown to the great majority of persons in ancient days, as it is at the present time in the Eastern Church and in Southern Europe; and that the quantity and quality of the food which now forms a full meal is only equivalent to what would have been an ex-

tremely spare one until comparatively modern days. The problem which the modern Christian has to solve, then, in this matter, is that of so reconciling the duty of fasting in Lent and at other times ordered by the Church, with the duty of properly accomplishing the work which God has set him to do, that he may fulfil both duties as a faithful servant of God.

It is impossible to lay down any general law as to the amount of abstinence from food which is thus compatible with modern duties; nor can any one, except a person possessed of much physiological acumen, determine what is to be the rule for another. But the general rules may be laid down, (1) that it is possible for all to diminish in some degree the quantity of their food on fasting-days without harm resulting; (2) that many can safely abstain altogether from animal food for some days in the week; (3) that food should be taken on fasting-days as a necessity, and its quality so regulated that it shall not be a luxury; (4) that all can deny themselves delicacies on fast-days which may be very properly used at other times.

In the First Homily on Fasting the objects of this discipline of the body are well stated thus: (1) "To chastise the flesh that it be not too wanton, but tamed and brought in subjection to the spirit." (2) "That the spirit may be more fervent and earnest in prayer." (3) "That our fast be a testimony and witness with us before God, of our humble submission to His high Majesty."

Finally, it may be remarked, that as the changed habits of life have diminished our capacity for abstaining from food for long periods, so they have increased our opportunities of sacrificing our pleasures by abstinence from luxuries. "Theatres, balls, private parties, novel-reading, mere ornamental pursuits, unnecessary delicacies, sumptuous costume,—these are things which may well be selected as the subjects of our abstinence, if, in Lent, or in our general life, we desire to adopt a stricter Christian habit than is commonly necessary." [Directorium Pastorale, p. 136.] From time so saved, many an hour can be gained in which to attend the Divine Service of the Church day by day, to use extra private devotions, and to engage in works of charity.

§ *Ash-Wednesday.*

The ancient ecclesiastical name given to the first day of Lent is *Caput Jejunii*, and the popular name of Ash-Wednesday has been acquired by it from the custom of blessing ashes made from

THE FIRST SUNDAY IN LENT.

The Collect.

[A. D. 1549.]

Matt. iv. 1, 2.
1 Pet. iv. 1.
1 Cor. ix. 27.
Eph. iv. 24, 30.
1 Cor. vi. 19, 20.
Phil. i. 20.
1 Tim. i. 17.

O LORD, who for our sake didst fast forty days and forty nights; Give us grace to use such abstinence, that our flesh being subdued to the Spirit, we may ever obey thy godly motions in righteousness and true holiness, to thy honour and glory, who livest and reignest with the Father and the Holy Ghost, one God, world without end. *Amen.*

DOMINICA I., QUADRAGESIMÆ.

Salisbury Use.

[INVOCAVIT.]

	<i>Modern English.</i>	<i>Salisbury Use.</i>	<i>Modern Roman.</i>	<i>Eastern.</i>
EPISTLE.	2 Cor. vi. 1—10.	2 Cor. vi. 1—10.	2 Cor. vi. 1—10.	Heb. xi. 24—26. 32—40.
GOSPEL.	Matt. iv. 1—11.	Matt. iv. 1—11.	Matt. iv. 1—11.	John i. 44—52.

the palms distributed on the Palm Sunday of the preceding year, and signing the cross with them on the heads of those who knelt before the officiating minister for the purpose, while he said, "Remember, man, that thou art dust, and unto dust shalt thou return." The Communion Service is an adaptation of this rite, as is further shown in the notes to that Office.

The Penitential Psalms are all used in the services of Ash-Wednesday, as they have been time immemorial, the 6th, 32nd, and 38th at Mattins, the 51st at the Communion, the 102nd, 130th, and 143rd at Evensong. The Collect is partly a translation of one used at the Benediction of the Ashes, and partly a composition of 1549 on the basis of other Collects of the Day. The Epistle and Gospel are those of the ancient Lectionary of St. Jerome. In the Durham book a rubric is inserted ordering that the Collect, Epistle, and Gospel of this day "are to serve until the Sunday following."

INTROIT.—Thou, O Lord, hast mercy upon all men, and hast nothing that Thou hast made: hiding Thy face from their sins because of their penitence, and sparing them because Thou art the Lord our God. Ps. Be merciful unto me, O God, be merciful unto me, for my soul trusteth in Thee. Glory be.

THE FIRST SUNDAY IN LENT.

Although the Sundays in Lent are not to be observed as fast-days, the devotional tone given to them is carefully assimilated to that of the season; and a constant memorial of it is kept up by the use of the Ash-Wednesday Collect after that of the week on Sundays as well as week-days. The ancient Use contained Collects for Mondays, Wednesdays, and Fridays in Lent.

The Collect for this Sunday has not been traced to any ancient source, but as it contains the first allusion to fasting, it may possibly come down from that distant time when Lent began on this day or the day following, instead of on Ash-Wednesday. In the ancient Use the Collect for this Sunday was, "O God, who dost cleanse Thy Church by the yearly observance of Lent; grant unto Thy family that what it strives to obtain from Thee by abstinence, the same it may perform in good works, through our Lord Jesus Christ."

The Gospel of the day sets forth the Lord Jesus perfecting His sympathy with our nature by undergoing temptation: and the first words of the Epistle point to the efficacious power of that temptation for the rescue from the Tempter of all who are tempted. Our Blessed Lord, as the Originator of a new spiritual nature which was to take the place of that lost by Adam, went through a similar trial to that of Adam; and that He might have perfect sympathy also with us who are open to the assaults of the

Evil One, "He was tempted like as we are." This representative character of Christ's Temptation is observable in the three forms which it took. (1) "Command these stones that they be made bread," was a parallel to that temptation of the senses which was laid before our first parents when they were invited to eat of the tree whose fruit had been forbidden by God. And in this primary temptation of sense all others are represented. But He Who fed five thousand by a miracle after one day's fasting, will not work a miracle to feed Himself after a fast of forty days: nor will He rise above the proper level of His human nature in His struggle with the enemy, because His time is not yet come. (2) "If Thou be the Son of God, cast Thyself down," was a temptation to make a premature and unnecessary display of His Divine Power, similar to the intellectual temptation set before our first parents, "Ye shall be as gods." The substance of it was, Can God do this? The answer was, "Thou shalt not tempt the Lord thy God."¹ (3) The first Adam was tempted to covet the gift of a Divine Intelligence, "Ye shall be as gods, knowing good and evil," and though God had given him sovereignty over the world in His own way, by a delegated authority, to seek it in another way, by the possession of Omniscience. So the third and strongest temptation offered to Him Who came to draw all men unto Him by His lifting up, was contained in the offer—doubtless one that could have been, in its way, realized—"All these things will I give Thee."

These three forms of temptation are comprehensive types of all that the Tempter has to offer,—sensual temptations, the seductions of vanity and pride, and the desire to go beyond God's will. Thus the ancient formulary which includes all sin under the three heads, "the world, the flesh, and the Devil," is strictly in keeping with the view of sin which is given to us in the Fall of the first, and the Victory of the Second Adam: and as we acknowledge ourselves to be sinners through our origin from the one, so we may see the full force of the prayer to the other, "By Thy Temptation, good Lord, deliver us," and seek spiritual strength in all times of spiritual danger by becoming "fellow-workers with Him" through the grace of God.

The week which begins with the first Sunday in Lent is one of the Ember weeks, the following Sunday being the canonical day for Ordinations.

INTROIT.—He hath called upon Me, and I will hear him. I will deliver him and bring him to honour: with long life will I satisfy him. Ps. Whoso dwelleth under the defence of the most High shall abide under the shadow of the Almighty. Glory be.

¹ It is observable that Simon Magus, who pretended to be divine, met his death in an attempt to display his power in this very manner.

THE SECOND SUNDAY IN LENT.

The Collect.

Hos. xlii. 9.
2 Cor. iii. 5.
xii. 9.
1 Thess. v. 23,
24.
Ps. xci. 3. 7.
Mark vii. 21. 23.

ALMIGHTY God, who seest that we have no power of ourselves to help ourselves; Keep us both outwardly in our bodies, and inwardly in our souls, that we may be defended from all adversities which may happen to the body, and from all evil thoughts which may assault and hurt the soul, through Jesus Christ our Lord. *Amen.*

DOMINICA II., QUADRAGESIMÆ.

[REMINISCERE.]

Oratio.

DEUS, qui conspicis omni nos virtute destitui interius exteriusque custodi; ut ab omnibus adversitatibus muniamur in corpore, et a pravis cogitationibus mundemur in mente. Per Dominum nostrum.

Salisbury Use.
Greg. Dom. ii.
in XL., ut et
ab.

	<i>Modern English.</i>	<i>Salisbury Use.</i>	<i>Modern Roman.</i>	<i>Eastern.</i>
EPISTLE.	1 Thess. iv. 1—8.	1 Thess. iv. 1—7.	1 Thess. iv. 1—7.	Heb. i. 10. ii. 3.
GOSPEL.	Matt. xv. 21—28.	Matt. xv. 21—28.	Matt. xvii. 1—9.	Mark ii. 1—12.

THE THIRD SUNDAY IN LENT.

The Collect.

Ps. xxxvii. 4.
x. 17.
Isa. xli. 10.
Rom. viii. 37.
1 Cor. xv. 57.

WE beseech thee, Almighty God, look upon the hearty desires of thy humble servants, and stretch forth the right hand of thy Majesty to be our defence against all our enemies, through Jesus Christ our Lord. *Amen.*

DOMINICA III., QUADRAGESIMÆ.

[OCULI.]

Oratio.

QUÆSUMUS, omnipotens Deus, vota humilium respice, atque ad defensionem nostram dexteram tuæ majestatis extende. Per Dominum nostrum Jesum Christum Filium tuum. Qui tecum vivit.

Salisbury Use.
Greg. Dom. iii.
in XL.

	<i>Modern English.</i>	<i>Salisbury Use.</i>	<i>Modern Roman.</i>	<i>Eastern.</i>
EPISTLE.	Eph. v. 1—14.	Eph. v. 1—9.	Eph. v. 1—9.	Heb. iv. 14. v. 6.
GOSPEL.	Luke xi. 14—28.	Luke xi. 14—28.	Luke xi. 14—28.	Mark viii. 34. ix. 1.

HYMNS.

EVENSONG.—*Ex more docti mystico.* H. N. 75. 47, H. A. M. 74.

COMPLINE.—*Christe, qui lux es et dies.* H. A. M. 83, D. H. p. clxxiii, A. A. 116.

MATTEWS.—*Summi largitor præmi.* H. A. M. 77.

LAUDS.—*Audi, benigne Conditor.* H. N. 20. 48, H. A. M. 75, C. H. 63.

These hymns are appointed for daily use during the first and second weeks in Lent.

THE SECOND SUNDAY IN LENT.

Our Lord's triumph in His own Person over Satan is followed up on this Sunday by a narrative of one of those cases in which He exhibited the same power for the good of others. "Grievously vexed with a devil" is a phrase which seems to point to an utter subjugation of the poor victim so afflicted to the power of the Evil One; and in that subjugation physical and mental evil were doubtless combined. He Who, having been tempted, was now able to succour them that are tempted, manifested that ability on this occasion by the effect of His will alone, so that without the use of any apparent means or any visible act, He caused the Evil One to give up his power over the afflicted, and in answer to the urgent prayer of the mother, "her daughter was made whole from that very hour." There is, doubtless, a connexion between

the fact told in the Gospel and the exhortation of the Epistle, the epithet designating the evil spirits who possessed their victims, and that by which St. Paul designates impurity, being the same; and several pieces of evidence pointing to extreme impurity of life as one result of possession. The Collect is moulded in the same lines of thought, acknowledging the power of the Tempter to assault the soul by evil thoughts, and our own inability to prevail against such assaults without the aid of Him by whom the Tempter was, and is overcome. The note of the day and week, therefore, so far as Lent looks to discipline, is a call to the subjugation of the sensual part of our nature by earnest prayer for a participation in the power of Him who was tempted, and yet came out of His temptation without sin, that He might succour others in His strength.

INTROIT.—Call to remembrance, O Lord, Thy tender mercies; and Thy loving-kindnesses, which have been ever of old. Let not our enemies triumph over us. Deliver us, O God of Israel, out of all our troubles. Ps. Unto Thee, O Lord, will I lift up my soul; my God, I have put my trust in Thee, let me not be confounded. Glory be.

THE THIRD SUNDAY IN LENT.

The dangerous sympathy which exists between human nature and evil is set forth on this Sunday with fearful intensity of expression. Our Lord had cast out another of those evil spirits

THE FOURTH SUNDAY IN LENT.

The Collect.

Ezra ix. 13, 14.
Micah vii. 9.
Isa. xl. 1, 2.
Rom. viii. 32.

GRANT, we beseech thee, Almighty God, that we, who for our evil deeds do worthily deserve to be punished, by the comfort of thy grace may mercifully be relieved; through our Lord and Saviour Jesus Christ. *Amen.*

DOMINICA MEDIA QUADRAGESIMÆ.

[LÆTARE.]

Oratio.

CONCEDE, quæsumus, omnipotens Deus, ut qui ex merito nostræ actionis affligimur, tuæ gratiæ consolatione respiremus. Per Dominum.

Salisbury Use.
Greg. Dom. iv.
in XL.

	<i>Modern English.</i>	<i>Salisbury Use.</i>	<i>Modern Roman.</i>	<i>Eastern.</i>
EPISTLE.	Gal. iv. 21—31.	Gal. iv. 22. v. 1.	Gal. iv. 22—31.	Heb. vi. 13—20.
GOSPEL.	John vi. 1—14.	John vi. 1—14.	John vi. 1—15.	Mark ix. 17—31.

which were permitted in His time to exercise their utmost power over men, that His glory might be shown in overcoming them; and some of those who witnessed the occurrence, finding no other way of explaining it, attributed it to "Beelzebub, the prince of the devils." This foolish and wicked way of accounting for the marvel our Lord met by two arguments; (1) Satan would not act against himself; (2) If Satan cast out Satan, then "the children" of the Jews, i. e. the Apostles to whom "the very devils were subject" through Christ's name, could only have cast them out by the same evil power. In the parallel passage, Matt. xi. 31, He also goes on to show how this wicked accusation was in danger of becoming the unpardonable sin; the Jews, in reality, calling the saving work of the Holy Spirit a "soul-destroying" work, that of the Destroyer of souls. Then the Lord declared that it is He alone Who can cast out Satan; He being stronger than the strong Evil One. From His words we may deduce the truth that all driving out of the Evil One is the work of Christ, as all sin is ultimately the work of the Enemy. He is the Stronger than the strong who drives evil from our nature, by purifying that nature in His own holy and immaculate Person; from each individual by the work of the same Person through the grace given in sacraments: and His power extends over every form of Satan's power, physical or mental infirmity, or spiritual disease. This personal power of Christ is illustrated by the words of St. Paul, "O wretched man that I am," through this power of Satan over me, "Who shall deliver me?" . . . "I thank God, through Jesus Christ our Lord."

After this comes that awful truth respecting re-possession which illustrates so fearfully the abiding sympathy of our nature with evil, and the intensification of Satan's power through every unresisted submission to the influence of it. This was spoken first of the generation of Jews among whom our Lord had come, and has its application to later times in the falling away of churches into heresy and worldliness. Satan was driven out from every position which he had taken up as soon as Christ appeared for the purpose of opposing him. But the sympathies of the nation were towards evil, and after their rejection of Christ and His Apostles their spiritual condition became far worse than it was even in our Lord's time when He called them a "generation of vipers." The vanquished strong man returned, and the horrors of sin among the Jews between our Lord's Ascension and the final destruction of Jerusalem,—the hardness of heart, the blindness, the cruelty,—were never exceeded. It is probable that the sway of Mahometanism in the East and in India is a return of the "strong man armed," with "seven others more wicked than himself," to nations among whom the Church had been received as a cleansing and garnishing power for a time, but was afterwards rejected when the new unbelief aroused old sympathies with evil.

The application of the same truth to individuals is obvious. The sense of Satan's power was so strong in the early Church as to lead it to make exorcism an invariable preliminary of baptism. Every act of penitence is a kind of exorcism, and every Absolution is the conquest of Satan by Christ. But unless the swept and garnished soul is pre-occupied with good, evil will return to it. In all Lenten discipline, therefore, the occupation of the soul by the sevenfold gifts of the Spirit is the true bar to the entrance of the seven evil spirits, and works of mercy will guard against the dangers and deadly sins to which inactive devotion makes it liable.

INTROIT.—Mine eyes are ever looking unto the Lord; for He shall pluck my feet out of the net. Turn Thee unto me and have mercy upon me; for I am desolate and in misery. Ps. Unto Thee, O Lord, will I lift up my soul; my God, I have put my trust in Thee, O let me not be confounded. Glory be.

HYMNS.

EVENSING.—*Ecce tempus idoneum.* H. N. 19. 49, H. A. M. 76.

COMPLINE.—*Christe, qui lux es et dies.* H. A. M. 83, D. H. p. clxxiii, A. A. 116.

MATTINS.—*Clarum decus jejunii.*

LAUDS.—*Jesu quadragenaria.* H. N. 21. 50.

These hymns are appointed for daily use during the third and fourth weeks of Lent.

MID-LENT, OR REFRESHMENT SUNDAY.

This day has been called *Dominica Refectionis* from a very ancient period, no doubt from the Gospel in which our Lord is set forth as feeding the five thousand by a miracle in the wilderness¹. It has at some times been observed as a day of greater festivity than was permitted on any other Sunday in Lent; and the Mi-Carême of the French Church still gives an illustration of this usage. In Rome also, the "Golden Rose" is blessed on this day, and presented by the Pope to some distinguished person who is considered to have done good service to the Church in the past year: and the ceremony is accompanied by festive observances which make Mid-Lent Sunday conspicuously different from the others of the season. The "comfort" of the Collect, the "free Jerusalem" springing out of the bondage of Sinai of the Epistle, and the Feast in the midst of the wilderness, all point the same way; as also does the ancient Officium or Introit.

The miracle which gives point to this Sunday exhibits our Lord as refreshing men literally by the operation of His Providence, and mystically as their spiritual Refresher.

¹ The first Lesson at Mattins is Genesis xliiii, which ends with the refreshment of his brethren by Joseph, who was, in so many particulars, a type of our Blessed Lord.

THE FIFTH SUNDAY IN LENT.

The Collect.

1 Pet. ii. 9, 10.
Ps. lli. 1.
1 Thess. v. 23.
2 Tim. iv. 18.

WE beseech thee, Almighty God, mercifully to look upon thy people; that by thy great goodness they may be governed and preserved evermore, both in body and soul, through Jesus Christ our Lord. *Amen.*

DOMINICA IN PASSIONE DOMINI.

[JUDIÇA.]

Oratio.

QUÆSUMUS, omnipotens Deus, familiam tuam propitius respice; ut te largiente regatur in corpore, et te servante custodiatur in mente. *Per.*

Salisbury Use.
Greg. Dom. v.
in XL. De
Passione
Domini.

	<i>Modern English.</i>	<i>Salisbury Use.</i>	<i>Modern Roman.</i>	<i>Eastern.</i>
EPISTLE.	Heb. ix. 11—15.	Heb. ix. 11—15.	Heb. ix. 11—15.	Heb. ix. 11—14.
GOSPEL.	John viii. 46—59.	John viii. 46—59.	John viii. 46—59.	Mark x. 32—45.

(1) From the literal point of view the miracle was stupendous, and well calculated to show that the Providence of Him "by whom all things were made" is able to take care of those whom He loves. Cornelius à Lapide, calculating from the Roman price of a loaf weighing from 8 to 10 ounces, concludes that the 200 pence named would have purchased 2000 such loaves. The average price of bread in England is 1½d. a pound, at which rate the same money would purchase about 914 pounds, a quantity not very far from this estimate. This weight of bread distributed among 5000 persons only would give not quite three ounces to each, about as much as is ordinarily eaten as an accompaniment to other food at dinner. But St. Matthew [xiv. 21] says that there were "women and children," besides "about five thousand men," and if these are reckoned at only 5000 more, the quantity of bread provided for each by the 200 pence would have been only 1½ ounce, literally "a little" as stated by Philip, and quite insufficient for satisfying a hungry person. But the actual quantity of bread present was much less than two hundred pennyworth, being only such a quantity as a *lad* could carry, five barley loaves (perhaps ten or twelve pounds in weight altogether), and in that case enough to give a piece of bread of *eight or ten grains weight* to each person. When Elisha's servitor said of "twenty loaves of barley and full ears of corn in the husk thereof," "What, should I set this before an hundred men?" it is no wonder that the servitor of Christ should say of the five barley loaves, "But what are these among so many," as ten thousand men, women, and children? Yet in the course of subdivision this small quantity of bread increased so as to be sufficient for a full meal; the persons so satisfied being evidently in a fasting, and therefore hungry condition. For such a full meal sixteen ounces of bread is not much, but 10,000 pounds of bread amounts to four and a half tons weight, a vast quantity, apparently a thousandfold exceeding that from which it originated. Such a calculation magnifies the miracle in appearance, yet it would have been as much an act of Divine power to have increased the bread twofold as a thousandfold; and acts of Divine power equally stupendous are daily being wrought around us by the loving-kindness of our Creator.

(2) The mystical meaning of the miracle is shown by the course of the several acts recorded in the eleventh verse of the Gospel; and they are plainly of an Eucharistic character.

a) The loaves are placed in the hands of Jesus, as an oblation is offered to God of the Bread and Wine.

β) Jesus gave thanks [*εὐχαριστήσας*, cf. Luke xxii. 19] before distributing them to the disciples, this eucharistization of the loaves endowing them with capacities which they did not previously possess.

γ) He distributes to His ministers as to persons receiving gifts from Him for the benefit of others.

δ) And by the intervention of these ministers, not by direct

communication between Jesus and the multitude, the latter receive the eucharistized bread by which they are satisfied.

Thus the mighty work of Christ in the midst of the wilderness is set before His Church in the midst of Lent as a sure token that the earth is the Lord's and the fulness thereof; and that both fasting and abundance are at His command: and still more as an earnest of that Divine gift the "Bread from Heaven," which He distributes to His people in the wilderness of this world, by the hands of ministers, for their spiritual refreshment and strength.

INTROIT.—Rejoice ye with Jerusalem, and be glad with her, all ye that love her: rejoice for joy with her, all ye that mourn for her; that ye may suck and be satisfied with the breasts of her consolations. Ps. I was glad when they said unto me, We will go into the house of the Lord. Glory be.

PASSION SUNDAY.

The name of Passion Sunday has been given to the second Sunday before Good Friday from time immemorial, because on that day the Lord began to make open predictions of His coming sufferings. The Epistle refers to our Lord's passion; the Gospel narrates the beginning of it in that fearful rejection of Him by the Jews; and the first Lessons at Mattins and Evensong are clearly prophetic of the redemption wrought by the sufferings of Christ. When the last attempt was made to alter the Prayer Book in 1688, it was proposed to substitute a Collect more in character with the day, which is as follows:—"O Almighty God, who hast sent Thy Son Jesus Christ to be an High Priest of good things to come, and by His own Blood to enter in once into the holy place, having obtained eternal redemption for us; mercifully look upon Thy people, that by the same Blood of our Saviour, who through the eternal Spirit offered Himself without spot unto Thee, our consciences may be purged from dead works, to serve Thee, the living God, that we may receive the promise of eternal inheritance, through Jesus Christ our Lord."

As the Divine Power of Christ was illustrated on the preceding Sunday by the miracle of the loaves and fishes, so on this day His Divine Nature is set forth in a conspicuous manner by the juxtaposition of the Gospel in which He used the words, "Before Abraham was, I am," with the first Lesson in which God is heard saying to Moses, "I AM THAT I AM: . . . thus shalt thou say unto the children of Israel, I AM hath sent me unto you." The conduct of the Jews shows that they recognized in our Lord's words an assumption of the incommunicable Name, and in that assumption a proclamation that He is God. This open and unlimited proclamation of His Divine Nature comes in on Passion Sunday, as the several manifestations of the glory of Christ come in before Christmas, that through the humiliation of the Cross, as

THE SUNDAY NEXT BEFORE EASTER.

The Collect.

James v. 11.
1 John iv. 9, 10.
Heb. ii. 9, 14, 16.
Phil. ii. 4—8.
Matt. xi. 29.
1 Pet. ii. 23.
Heb. xii. 3.
Phil. iii. 9, 10.

ALMIGHTY and everlasting God, who, of thy tender love towards mankind, hast sent thy Son our Saviour Jesus Christ, to take upon him our flesh, and to suffer death upon the cross, that all mankind should follow the example of his great humility; Mercifully grant that we may both follow the example of his patience, and also be made partakers of his resurrection; through the same Jesus Christ our Lord. *Amen.*

DOMINICA IN RAMIS PALMARUM.

Oratio.

OMNIPOTENS sempiternus Deus, qui humano generi ad imitandum humilitatis exemplum, Salvatorem nostrum carnem sumere, et crucem subire fecisti: concede propitius, ut et patientiæ ipsius habere documenta, et resurrectionis consortia mereamur. Per eundem.

Salisbury Use.
Greg., Gelas.
Dom. in ramis
palmarum.

	<i>Modern English.</i>	<i>Salisbury Use.</i>	<i>Modern Roman.</i>	<i>Eastern.</i>
EPISTLE.	Phil. ii. 5—11.	Phil. ii. 5—11.	Phil. ii. 5—11.	Phil. iv. 4—9.
GOSPEL ^o	Matt. xxvii. 1—54.	Matt. xxvi. and xxvii.	Matt. xxvi. and xxvii.	John xii. 1—18.

through that of the manger, we may behold the eternal Son of God: and see rays of Divinity shed from His crucified Body.

INTROIT.—Give sentence with me, O God, and defend my cause against the ungodly people: O deliver me from the deceitful and wicked man, for Thou art the God of my strength. Ps. O send out Thy light and Thy truth that they may lead me, and bring me unto Thy holy hill, and to Thy dwelling. Glory be.

HYMNS.

EVENSING.—*Vexilla Regis prodeunt.* H. N. 22. 51, H. A. M. 84.

COMPLINE.—*Cultor Dei memento.* D. H. p. clxxiv.

MATTINS.—*Pange, lingua, gloriosi.* H. N. 23. 52.

LAUDS.—*Lustra sex qui jam peracta.* H. N. 24. 53.

These hymns are appointed for daily use up to Maundy Thursday; from which time to the Octave of Easter no hymns were sung according to Salisbury Use.

PALM SUNDAY.

The last week of Lent has ever been observed by Christians as a time of special solemnity; and from the awfully important events which occurred in the last week of our Lord's life, which it represents to us, it has been called, from primitive times, the Great Week and the Holy Week. During this period there was, as early as the days of St. Chrysostom, a general cessation of business among the Christian part of the people: fasting was observed with greater strictness than in the other weeks of Lent, and special acts of mercy and charity were engaged in by all, the Emperors (when they had become Christian) setting an official example by ceremonies of which our Royal Maundy is a relic.

The first day of the Holy Week is called Indulgence Sunday in the Lectionary of St. Jerome, and in many other later writers. This name has been explained by a custom of the Christian Emperors, who used to set prisoners free and close all courts of law during Holy Week. But it seems to have been in use before this practice originated, which was not earlier than the end of the fourth century. It has also been supposed to be connected with the reconciliation of penitents. In the Sacramentary of St. Gregory there is the phrase, "Per Quem nobis indulgentia largitur," in the proper preface for this day, and "ut indulgentiam percipere mereamur," in the Collect for Tuesday; from which it may be inferred that the name Indulgence Sunday (and Indulgence Week) originally pointed to our Lord's work of redemp-

tion, and His great love in going forward willingly on this day to meet His sufferings. The day is also called Hosanna Sunday in some parts of Europe and the East.

But a far more common name is that by which it is familiarly known to us, that of Palm Sunday. It is called *Dominica in ramis palmarum* in the Sacramentary of St. Gregory, and *Dominica in ramis olivarum* in that of St. Ambrose, and in the former there is a plain reference to the ceremony of branch-bearing as one then in use, as well as to the act of the Jews which originally gave the name to the Sunday. The words are in the Benediction of the people: "May Almighty God grant unto you, that as ye present yourselves before Him with branches of palms and of other trees, so after your departure from this life ye may attain to appear before Him with the fruit of good works and the palm of victory." In the Ambrosian rite it is not so clear that the ceremony was then in use; but St. Chrysostom mentions the shaking of the palm-branches [*σειειν τὰ βῆτα*] as one of the customs of the day in one of his sermons for the Great Week.

In the ancient English Church the Benediction of the Palms took place before the beginning of the Holy Communion. First an Acolyte read Exod. xv. 27—xvi. 10, the narrative of Israel's encamping by the twelve wells and threescore and ten palm-trees of Elim: Then a Deacon read John xii. 12—19, the account of our Lord's triumphal entry. After this the palm, yew, or willow branches being laid upon the Altar, the Priest (vested in a red silk cope) pronounced an exorcism and a blessing over them, which were followed by four Collects. A procession then passed round the Church, singing Anthems, and distributing the branches; after which began the celebration of the Holy Eucharist. The custom is still represented in some places by decking the church with willow-branches on Palm Sunday; and almost every where by the country people bearing them in their hands as they walk out in the afternoon.

On this day the Church has always begun to set before God and men the Gospel account of the Passion of our Lord. In the Lectionary of St. Jerome, and in the ancient missals of the Church of England, St. Matthew's narrative, or "The Passion according to St. Matthew," was fixed for the Gospel on Palm Sunday, that of St. Mark on Tuesday, that of St. Luke on Wednesday, and that of St. John on Good Friday¹. Until 1661 the

¹ The Passion was said in a very remarkable manner, and is printed accordingly in the Salisbury Missal. Instead of the whole being said by the Gospeller, it was apportioned among three persons, apparently choir men. Those words which were spoken by the Jews or the disciples had the letter

MONDAY BEFORE EASTER.

FERIA II., POST DOMINICAM IN RAMIS SALISBURY USE.
PALMARUM.

	<i>Modern English.</i>	<i>Salisbury Use.</i>	<i>Modern Roman.</i>	<i>Eastern.</i>
EPISTLE.	Isa. lxiii. 1—19.	Isa. l. 5—10.	Isa. l. 5—10.	
GOSPEL.	Mark xiv. 1—72.	John xii. 1—36.	John xii. 1—9.	Matt. xxiv. 3—37.

TUESDAY BEFORE EASTER.

FERIA III., POST DOMINICAM IN RAMIS SALISBURY USE.
PALMARUM.

	<i>Modern English.</i>	<i>Salisbury Use.</i>	<i>Modern Roman.</i>	<i>Eastern.</i>
EPISTLE.	Isa. l. 5—11.	Jer. xi. 18—20.	Jer. xi. 18—20.	
GOSPEL.	Mark xv. 1—39.	Mark xiv. and xv.	Mark xiv. and xv.	Matt. xxiv. 36. xxvi. 2.

26th and 27th chapters of St. Matthew were still read for the Gospel on Palm Sunday, and the 18th and 19th of St. John on Good Friday; but a marginal note in Sancroft's writing is appended to both these days in the Durham book, directing the first chapter to be left out in each case, because it is appointed to be read in the Second Lesson.

The distinguishing characteristic of this day in the last week of our Lord's life is not represented in any of the Scriptures for the day, which are altogether occupied with our Lord's Passion. This arises from the change made in 1549, when the service for the Benediction of the Palms was set aside (in which this characteristic of the day was fully commemorated), and only the Ancient Mass of the day (which was commemorative of the Passion) retained. This oversight is to be regretted, as there is clearly a connexion between the usage of palm-bearing and the Divine ritual, both of Sinai and the New Jerusalem. One of God's commands to the Jews was, "Ye shall take you on the first day the boughs of goodly trees, branches of palm-trees, and the boughs of thick trees, and willows of the brook; and ye shall rejoice before the Lord your God seven days" [Levit. xxiv. 40]. And in the Revelation St. John writes, "After this, I beheld, and lo, a great multitude, which no man could number, of all nations, and kindreds, and people, and tongues, stood before the throne, and before the Lamb, clothed with white robes, and palms were in their hands" [Rev. vii. 9].

INTROIT.—Be not Thou far from me, O Lord: Thou art my succour, haste Thee to help me. Save me from the lion's mouth: Thou hast heard me from among the horns of the unicorns. Ps. My God, my God, look upon me; why hast Thou forsaken me? [*Non dicitur, Gloria Patri.*"]

MONDAY IN HOLY WEEK.

The distinctive memorial of this day is the act of our Blessed Lord in destroying the barren fig-tree. Having left Jerusalem in the evening of Palm Sunday and retired to Bethany, He returned to the city in the morning, and on His way He was hungry; and seeing a fig-tree afar off, having leaves, He came, if haply He might find any thing thereon; and when He came to it, He found nothing but leaves; for the time of figs was not yet. And Jesus answered and said unto it, "No man eat fruit of thee hereafter for ever" [Mark xi. 14]. From thence He went to the Temple, and cleansed it from the presence of those who carried their merchandise into the very house of God. Both actions are compared by ritualist commentators to that separation of the firmament from the subjacent waters out of which the earth was

"a" prefixed, and were directed to be sung or said [cantari aut pronuntiari] by an *alto* voice; the words of our Lord were marked "b," and to be sung by a *bass* voice; those of the Evangelist "m," to be sung by a *tenor* [media]. This singular custom was observed in reading the Passion from each of the four Evangelists.

to spring, and which took place on the second day of the week of the Creation. As the Almighty Creator separated the waters above from the waters beneath, so the righteous Judge of all the earth separates the barren tree from the fruitful, the house of prayer from the house of covetousness and dishonesty. Thus He foreshadowed the result of His Passion, by which the latter days of the Lord would be severed from the former days of the world; and His final Judgment, in which the evil, and those who have been unfruitful in good works, will be altogether cast out of His Kingdom.

INTROIT.—Plead Thou my cause, O Lord, with them that strive with me; and fight Thou against them that fight against me. Lay hand upon the shield and buckler, and stand up to help me. Ps. Bring forth the spear, and stop the way against them that persecute me.

TUESDAY IN HOLY WEEK.

This was the last day of our Lord's public teaching and ministration. Having retired to Bethany for the night on the evening of Monday as on that of Sunday, He again returned to the city in the morning of this day, and "as they passed by, they saw the fig-tree dried up from the roots." In the Temple, the scribes and elders required from our Lord an explanation of the authority by which He did the things which He had done there, clearing the Temple of buyers and sellers, and claiming it as the house of His Father. The events of the day are then recorded with much fulness by the Evangelist. Our Lord spoke the parables of the Father and his two sons, the Vineyard let out to husbandmen, the Marriage feast and the Wedding garment. Each sect of the Jews, the Herodians, the Sadducees, and the Pharisees, endeavoured to entangle Him into some discourse which could be made the ground of an accusation against Him. Our Lord pronounced the eight woes, and then departed from the Temple to speak nearly His last words to the Jews in the parables of the Ten Virgins, the Talents, and the Sheep and the Goats. The latest public event of the day appears to be that recorded in St. John xii. 28—36, when in reply to the prayer, "Father, glorify Thy name," there came a voice from heaven saying, "I have both glorified it, and will glorify it again." After this voice our Lord spoke of His "lifting up" upon the Cross. He then gave His final words of public warning, "Yet a little while is the Light with you. Walk while ye have the Light, lest darkness come upon you; for he that walketh in darkness knoweth not whither he goeth. While ye have light, believe in the Light, that ye may be the children of light." [John xii. 35.] As soon as these words were spoken, the public teaching of the Light of the world came to an end, and He shone no more upon the multitude until He displayed Himself "lifted up" for their salvation: "These things spake Jesus, and departed, and did hide Himself from them." [John xii. 36.]

WEDNESDAY BEFORE EASTER.

FERIA IV., POST DOMINICAM IN RAMIS *Salisbury Use.*
PALMARUM.

	<i>Modern English.</i>	<i>Salisbury Use.</i>	<i>Modern Roman.</i>	<i>Eastern.</i>
EPÍSTLE.	Heb. ix. 16—28.	Isa. lxii. 11. lxiii. 7. liii. 1—12.	Isa. lxii. 11. lxiii. 7. liii.	
GOSPEL.	Luke xxii. 1—71.	Luke xxii. and xxiii.	Luke xxii. and xxiii.	Matt. xxvi. 6—16.

THURSDAY BEFORE EASTER.

FERIA V., IN CÆNA DOMINI [*vel, EB-* *Salisbury Use.*
DOMADÆ SANCTÆ].

	<i>Modern English.</i>	<i>Salisbury Use.</i>	<i>Modern Roman.</i>	<i>Eastern.</i>
EPÍSTLE.	1 Cor. xi. 17—34.	1 Cor. xi. 20—32.	1 Cor. xi. 20—32.	1 Cor. xi. 23—32.
GOSPEL.	Luke xxiii. 1—49.	John xiii. 1—15.	John xiii. 1—15.	Matt. xxvi. 2. xxvii. 2.

Henceforth He lived to instruct His Apostles concerning their office and His, and to suffer.

INTROIT.—We ought to glory in the cross of our Lord Jesus Christ, in Whom is our salvation, life, and resurrection; by Whom also we are ransomed and saved. Ps. God be merciful unto us, and bless us, and lift up the light of His countenance upon us, and be merciful unto us.

WEDNESDAY IN HOLY WEEK.

The fourth day of the Holy Week marks the actual beginning of the events which reached their climax on Good Friday, the conspiracy of the Sanhedrim, and the agreement between them and Judas; on account of which it is always reckoned the day of the Betrayal. It is the first of the week-days for which proper lessons are appointed; but singularly enough, no second lessons are appointed for Evensong either on Wednesday or Thursday. Among the ancient offices of the Church of England for Holy Week there was one called *Tenebræ*, which was used late in the evening of this and the two succeeding days; and was, doubtless, a relic of the ancient night-watchings which accompanied the fastings of this week, and especially the last four days of it, in primitive times. The ceremony from which the distinctive name of the office was derived consisted of the gradual extinction of lights one by one until the Church was left in darkness; when this significant memorial of the Crucifixion was heightened in its terrible solemnity by the singing of the fifty-first Psalm, the same that is said in the Communion Service¹.

It was on this and the following day that our Blessed Lord gave to His Apostles those instructions and encouragements which are recorded in the thirteenth and four following chapters of St. John's Gospel. They are given, it is probable, only in the form of a summary, yet even in that form they provide the Church with a solid foundation of doctrine respecting the continual Presence of her Lord, and her true unity through union with Him. The day seems to have been spent in the retirement of Bethany; and was apparently concluded by another festival, which ended our Lord's intercourse with the family of Lazarus, the next being spent with His Apostles alone.

INTROIT.—At the Name of Jesus every knee shall bow, of things in heaven, and things in earth, and things under the earth. Because the Lord having become obedient unto death, even the death of the Cross; therefore Jesus Christ is Lord, to the glory of God the Father. Ps. O Lord, hearken to my prayer, and let my cry come unto Thee.

¹ Gunning, in his Lent Fast, states that this day was called "Tenable Wednesday." Probably this was a popular corruption of *Tenebræ Wednesday*.

MAUNDY THURSDAY.

The fifth day of Holy Week was honoured by the Institution of the Holy Eucharist, and the names by which it has been known have almost always been derived from this distinguishing feature of the day. As early as the time of St. Augustine [Ep. liv. or cxviii. ad Januar.] it is called *Dies Cœnæ Domini*; and in later times *Natalis Eucharistiæ*, or *Natalis Calicis*. The English name of Maundy Thursday also points to the same holy event, being a vernacular corruption of *Dies Mandati*; the day when our Lord commanded His disciples to love one another as He had loved them, to wash one another's feet in token of that love, and above all to "Do This,"—that is, to celebrate the Holy Eucharist after the pattern which He had shown them,—as the sacramental bond of the Love which He had commanded. The day has also been called *Feria mysteriorum*, *Lavipedium*, and *μεγάλη πεντάς*. In the Durham book, Cosin added a second title to the present one, writing it "Thursday before Easter, commonly called Mandie Thursday."

Our Lord's act of humility in washing the feet of His disciples took a strong and lasting hold upon the mind and affection of the Church; and the terms in which He commanded them to follow His example not unnaturally led to a belief that the usage was in some manner and degree binding upon their successors. In later ages, however, the Church of England has considered the commandment to follow our Lord's example in that particular, as one which is not of a perpetual obligation; while "Do this in remembrance of Me," is one the unceasing obligation of which has never been doubted.

Our Lord did, in fact, take a local and temporary custom, and use it as a practical exponent of His extreme humility, according to His words, "I am among you as He that serveth," intensified as they are by St. Peter's remonstrance, "*Thou shalt never wash my feet.*" At His hands the act had doubtless a sacramental efficacy, such as followed every touch of His holy Person when It came in contact with those who had faith to receive His blessing. But the command with which He accompanied the act related to the humility and love symbolized by it, and did not entail a repetition of it by the Apostles or the Church of later ages, under circumstances in which the customs of a country or of a period had ceased to recognize the literal act as a necessity of social life. As a symbolical usage the Church has however always, in some parts of the world, retained the custom of washing the feet of the poor on Maundy Thursday, Sovereigns, Bishops, and Clergy thus marking their obligation to follow their Saviour in humility and love for His poor. It was continued by our English Sovereigns until the latter part of the 17th century, and by the Archbishops of York on their behalf until the middle of the last century. The ceremony formed

GOOD FRIDAY.

The Collects.

Eph. iii. 14, 15.
ii. 19.
Mark xiv. 44—
46.
John iii. 14, 15.

ALMIGHTY God, we beseech thee graciously to behold this thy family, for which our Lord Jesus Christ

FERIA VI, IN DIE PARASCEVES.

[Ad Completorium. Oratio.]

RESPICE quæsumus, Domine, Salisbury Use. super hanc familiam tuam, pro qua Dominus noster Jesus Christus non

part of a service, which is still represented (though in an altered form) by the "Royal Maundy" office, and was connected with special acts of almsgiving on the part of the Sovereign, which are likewise retained¹.

¹ The following is the Service as now used in the Chapel Royal at Whitehall, on this day:—

OFFICE FOR THE ROYAL MAUNDY.

Exhortation, Confession, Absolution, &c.

Proper Psalm. Ps. xlii.

*First Lesson, St. Matthew xxv. 14—30.**First Anthem.*

Blessed is he that considereth the poor and needy: the Lord shall deliver him in the time of trouble.—Ps. xlii. 1.

£1 15s. DISTRIBUTED TO EACH WOMAN.

TO EACH MAN SHOES AND STOCKINGS.

Second Anthem.

Hide not Thou Thy face from us, O Lord, and cast not off Thy servants in Thy displeasure: for we confess our sins unto Thee, and hide not our unrighteousness.

For Thy mercy's sake deliver us from all our sins.

WOOLLEN AND LINEN CLOTHS DISTRIBUTED.

Third Anthem.

O Lord, grant the Queen a long life, that her years may endure through out all generations.—Ps. lxi. 6.

She shall dwell before God for ever: O prepare Thy loving mercy and faithfulness, that they may preserve her.—Ps. lxi. 7.

As for her enemies, clothe them with shame: but upon herself let her crown flourish.—Ps. cxviii. 19.

PURSES DISTRIBUTED.

*Second Lesson, St. Matthew xxv. 31—46.**Fourth Anthem.*

Who is this that cometh from Edom, that is glorious in his apparel, travelling in the greatness of his strength? I that speak in righteousness, mighty to save.—Isa. lxiii. 1.

Doubtless Thou art our Father, our Redeemer; Thy name is from everlasting.—Isa. lxiii. 16.

Hosanna to the Son of David; Blessed is he that cometh in the name of the Lord: Hosanna in the highest! Amen.—Matt. xxi. 9.

O LORD, the Sovereign of the world, we acknowledge that Thine is the greatness, and the power, and the glory, and the victory, and the majesty; for all that is in the heaven and in the earth is Thine. Thine is the kingdom, O Lord, and Thou art exalted as head above all; both riches and honour come of Thee, and Thou reignest over all. In Thy hand is power and might, and in Thy hand it is to make great, and to give strength unto all. Now therefore, our God, we thank Thee and praise Thy glorious name, that Thou hast not only bestowed greatness and majesty upon our Sovereign Lady Queen Victoria, but hast given her a heart also to take compassion on them that are below her, and show mercy upon the poor and needy. Accept, most gracious God, of this tribute, which she pays unto Thee, the giver of all good things, and make her still more fruitful and abundant in these, and in all other good works, that by mercy and truth she may be preserved, and her throne upholden by mercy. And stir up the hearts of all those who have now been partakers of her bounty, to be truly thankful unto Thee for it, and both to bless and praise Thee continually for setting such a pious Princess over us, and also pray most earnestly that Thou wouldst reward her charity with a long and prosperous reign in this world, and with a heavenly kingdom in the world to come; through Jesus Christ our Lord and only Saviour. Amen.

Most blessed God, who art good and dost good and takest pleasure in those that fear Thee and imitate Thy goodness, look down from Heaven, the throne of Thy glory, upon us Thy servants here prostrate before Thee, who thankfully acknowledge that we have nothing but what we have received from Thee, and therefore can give Thee nothing but what is Thine own. Fill our hearts, we beseech Thee, with the lively sense of Thy fatherly goodness, which hath bestowed so many benefits upon us that we are not able to number them, and likewise given us to understand the happiness of doing good with them; and assist us with the power of Thy holy Spirit, that we may be faithful stewards of Thy manifold gifts and graces, following the steps of our Lord and Master Christ, whom Thou hast sent into the world, to be a pattern to us of humble goodness; unto which we pray Thee to quicken us by the consideration that we are but strangers and sojourners as all our fathers were, our days on the earth being as a shadow, and there is no abiding: That so nothing may tempt us to be high-minded, nor trust in uncertain riches, but in Thee, the living God, who givest us all things

In the ancient offices of the Church of England there were several special observances on this day. First (after the hour of Nones) came the reconciliation of penitents, a custom handed down from primitive days. The Holy Communion was celebrated at the same time with Vespers, and there was a special reservation, the rubric being, "Ponantur a subdiacono tres hostiæ ad consecrandum: quarum duæ reserventur in crastinum, una ad percipiendum a sacerdote: reliqua ut ponatur cum cruce in sepulchro." In the evening the altars were washed with wine and water, and the Maundy ceremonies performed, two clergy of the highest rank present washing the feet of all in the choir, and of each other. The rubric in the Salisbury Missal regulating these ceremonies begins, "Post prandium² convenienti clerici ad ecclesiam, ad altaria ablunda; et ad mandatum faciendum; et ad completorium dicendum." While the pavilium was going on, the Psalms *Deus misereatur, Ecce quam bonum, Miserere, Beati immaculati, and Audite hæc, omnes gentes*, were sung; the Antiphon to *Deus misereatur* being "Mandatum novum do vobis: ut diligatis invicem," from the first word of which the ceremony took its name. At its conclusion a sermon was preached, and then a "loving cup" (called "caritatis potum" in the rubric) was passed round to all who had taken part in its performance. The whole ended with this collect,—"Adesto quæsumus, Domine, officio servitutis nostræ; et quia Tu pedes lavare dignatus es Tuis discipulis; ne despicias opera manuum Tuarum, quæ nobis retinenda mandasti: sed sicut exteriora hic abluuntur inquinamenta corporum; sic a Te omnium nostrorum interiora mudentur peccata, quod Ipse præstare digneris Qui cum Deo Patre et Spiritu Sancto vivis et regnas Deus. Per." A vestige of this ceremony is still retained in the Chapel Royal, the Bishop who acts as Almoner, and his assistants, being girded with long linen towels during the distribution of the Alms.

Maundy Thursday is also the day on which the Chrism or anointing oil has been consecrated from time immemorial, and in all parts of the Church throughout the world. In the Eastern Church the Holy Sacrament to be reserved for the sick in the ensuing year is also consecrated on this day, the one element being saturated with the other, divided into small morsels, and carefully dried; after which it is preserved in a receptacle at the back of the Altar. [See Notes on Comm. of the Sick.]

INTROIT.—We ought to glory in the cross of our Lord Jesus Christ, in Whom is our salvation, life, and resurrection; by Whom also we are ransomed and saved. Ps. God be merciful unto us, and bless us, and lift up the light of His countenance upon us, and be merciful unto us.

GOOD FRIDAY.

This day is not one of man's institution, but was consecrated by our Lord Jesus Christ when He made it the day of His most holy Passion. It is impossible that the anniversary of our Lord's

richly to enjoy, that we may do good, and be rich in good works, ready to distribute, willing to communicate, laying up in store for ourselves a good foundation for the time to come, that we may lay hold on eternal life. And we most humbly beseech Thee, in a special manner to bless Her Majesty, whom Thou hast set over us; keep this ever in the thoughts of her heart, to endeavour to do much good with the power which Thou hast given her, and thereby magnify Thee exceedingly in the sight of all the people of these Realms, and bestow upon her such royal majesty as hath not been on any prince before her: All which we beg for the sake of Jesus Christ, our most blessed Lord and Saviour, to whom with Thee and the Holy Ghost be all honour and glory, world without end. Amen.

Then follows the Prayer for the Queen, and so on to the end.

² As early as St. Augustine's time there appear to have been two celebrations on this day, "bis in cena Domini Eucharistia datur, mane propter prædantes, ad vesperum propter jejunantes." [Aug. Ep. 118.]

Acts ii. 22, 23.
Rev. i. 18.

was contented to be betrayed, and given up into the hands of wicked men, and to suffer death upon the cross, who now liveth and reigneth with thee and the Holy Ghost, ever one God, world without end. *Amen.*

1 Cor. xii. 12,
13, 26.
Eph. ii. 19-22.
vi. 18.
Rom. xii. 5-8.
Col. iii. 23, 24.

ALMIGHTY and everlasting God, by whose Spirit the whole body of the Church is governed and sanctified; Receive our supplications and

dubitavit manibus tradi nocentium, et crucis subire tormentum. Qui tecum vivit et regnat in unitate. Greg. in fer. iv. & vi. post palmas.

Universis ordinibus. Oratio [iii.].

OMNIPOTENS sempiternae Deus, Salisbury Use. Greg. ut supra. Gelas. in passione Dom. cujus spiritu totum corpus ecclesiae sanctificatur et regitur; exaudi nos pro universis ordinibus supplicantes;

sufferings could ever have passed by as a common day in those times when the memory of them was yet so recent, and when a daily fellowship in them [Phil. iii. 10. Col. i. 24] was so continually before the eyes of Christians in the martyrdoms of His faithful servants. It is spoken of under the name of the Paschal Day¹ in very early Christian writings [Tert. de Orat. xviii.], but in later ages it was chiefly known by the names *Παρασκευή*, Dies Parasceves, the Day of Preparation, or Dies Dominicae Passionis, the Day of our Lord's Passion. In early English times it was known as Long Friday [Ælfric's Can. 37, A.D. 957. A. Sax. Chron. A.D. 1137], but its present beautiful appellation is the one by which it has now been popularly known for many centuries.

Very soon after midnight our Blessed Lord was betrayed and apprehended; and about day-dawn He was taken before the judicial High Priest Annas, the ceremonial High Priest Caiaphas, and the Sanhedrim or great Council of the Jews [Matt. xxvi. 64. Mark xiv. 62. Luke xxii. 70], where He was accused of blasphemy. After that He was sent bound to Pilate, before whom He was charged with treason; and by Pilate sent to Herod as belonging to his jurisdiction. Having been mocked and insulted by Herod, the holy Jesus was sent back by him to the Roman governor, declared innocent of all crime against the state, yet scourged, to please the Jews, and for the same reason sentenced to be crucified [Matt. xxvii. 3, 25. Mark xv. 1, 14. Luke xxiii. 1, 21. John xviii. 28; xix. 6]. Then He was insulted with the purple robe, and the reed sceptre, and a *corona radiata* made of thorns; was buffeted and spit upon; and afterwards led forth from the Prætorium by the Via Dolorosa to Calvary.

At the third hour [9 A.M. "Tierce"] our Lord, having borne His cross, or a portion of it, until His exhausted Body had fainted under the burden, was nailed to it upon Mount Calvary without Jerusalem, the two thieves being crucified on either side with the intention of adding shame to His sufferings. From the Cross He spoke His last words. As they fastened His limbs upon it He cried, "Father, forgive them; for they know not what they do" [Luke xxiii. 34]; when the penitent thief prayed for His remembrance in His Kingdom, He said, "Verily, I say unto thee, To-day shalt thou be with Me in Paradise" [Luke xxiii. 40]. When He beheld His mother and the beloved disciple standing at the foot of His Cross, He said to the one, "Woman, behold thy son," and to the other, "Behold thy mother" [John xix. 26].

At the sixth hour [Noon, "Sexts"] ensued the darkness, and the earthquake; and during the three hours which followed before the return of light, it is supposed that our Lord's greatest sufferings took place, the veiling of the Father's Presence, the agony of "being made sin for us," and of having "laid upon Him the iniquity of us all." The awful mystery of these three hours was summed up in an ancient Litany, in the words, "By Thine unknown sufferings, Good Lord, deliver us" [Matt. xxvii. 45. Mark xv. 33. Luke xxiii. 44].

At the ninth hour [3 P.M. "Nones"] the climax of this awful period was reached when our Lord spoke the words, "Eloi!

Eloi! Lama Sabacthani," which are the first words of the twenty-second Psalm [Matt. xxvii. 46. Mark xv. 34]. After this He said "I thirst" [John xix. 28], and when He had received the vinegar, "It is finished" [Matt. xxvii. 48. Mark xv. 36. Luke xxiii. 46. John xix. 30]; for now He knew that "all things were accomplished" of the Sacrifice for sin, and the sufferings of Him in whom, sinless, all sinners were then represented before God. Then, crying with a loud voice, as with a willing expiration of that life which no man could take from Him, He laid it down of Himself with the last of His seven words from the Cross, "Father, into Thy hands I commend My Spirit" [Luke xxiii. 46], which are also words uttered by David in the spirit of prophecy in the sixth verse of the thirty-second Psalm.

It must have been shortly after this that the body of our Blessed Lord was taken down from the cross, for the Sabbath began at six o'clock in the evening, and that Sabbath being "an high day," the Jews entreated Pilate that it might be removed from the Cross (to be cast into the pit where the bodies of malefactors were thrown) before the legal beginning of the festival. Thus on the eve of the Sabbath, after being subjected to eighteen hours of mental agony and bodily suffering, the holy Jesus fulfilled, in His Body and Soul, the words of the Complains Psalm, "I will lay Me down in peace, and take My rest: for it is Thou, Lord, only that makest Me to dwell in safety."

With this Passion of our dear Lord in view, it has ever been the object of the Church to make the devotions of Good Friday such as should help Christians to realize the magnitude of the Sacrifice that He offered, of the sins by which it was made necessary, and of the Mercy which moved Him to offer it. "On the Paschal Day," writes Tertullian [de Orat. xviii.], "the strict observance of the fast is general, and as it were public," not restricted to those who professed to lead a life of closer devotion than others; works of charity were permitted, even to the extent of the rich ploughing the land of the poor, but no other labour was engaged in on this holy day. In all Churches the Passion of our Lord, as narrated in the Gospels, has ever formed the central subject of the day's meditation and teaching, while psalm and prophecy have been gathered around it in saddened and penitent tones, the more perfectly to represent before God and man the events of this central Day of the world's history. In the ancient services of the Day one was conspicuous, in which the Clergy and people showed their veneration for the atoning work of Christ by ceremonies which acquired the popular name of "creeping to the Cross;" in which the image of the Cross was placed in the front of the altar, that they might more thoroughly realize the spirit of penitents "before whose eyes Jesus Christ hath been evidently set forth, crucified among them" [Gal. iii. 1], while they gave Him the lowliest adoration of their bodies¹. During this ceremony of prostration before the Cross, the "Reproaches," followed by the hymns, "Sing, my tongue, the glorious battle," and "The Royal Banners forward go," were sung to their well-

¹ The popular feeling of reverence towards the Cross never died out. It is illustrated even by the Pilgrim's Progress, in which Christian, standing before "the Image of a Cross," says, "He hath given me rest by His sorrows, and life by His death."

¹ Πάσχα σταυρωσιμον, the Paschal Day of the Crucifixion, as Easter Day was called Πάσχα ἀναστάσιμον, the Paschal Day of the Resurrection.

prayers, which we offer before thee for all estates of men in thy holy Church, that every member of the same, in his vocation and ministry, may truly and godly serve thee; through our Lord and Saviour Jesus Christ. *Amen.*

Wisd xi. 23—26.
Matt. v. 45.
Ezra xviii. 30.
Rom. x. 1.
2 Cor. iv. 3, 4.
Hos. iv. 6.
Isa. v. 24.
Luke xv. 4—6.
John x. 11. 14—16.
Matt. vi. 10—13.

O MERCIFUL God, who hast made all men, and hatest nothing that thou hast made, nor wouldest the death of a sinner, but rather that he should be converted and live; Have mercy upon all Jews, Turks, Infidels, and Heretics, and take from them all ignorance, hardness of heart, and contempt of thy Word; and so fetch them home, blessed Lord, to thy flock, that

ut gratiæ tuæ munere ab omnibus tibi gradibus fideliter serviatur. Per Dominum. In unitate ejusdem.

Pro Hereticis. Oratio [vii.]

Salisbury Use.
Greg. Gelas. ut supra. Prosper African. de vocat. Gent. l. 4.

O MNIPOTENS sempiternæ Deus, qui salvas omnes homines, et neminem vis perire; respice ad animas diabolica fraude deceptas, ut omni hæretica pravitate deposita, errantium corda respiscant, et ad veritatis tuæ redeant unitatem. Per Dominum.

Pro Perfidis Judæis. Oratio [viii.]

Salisbury Use.
Greg. Gelas. ut supra.

Omnipotens sempiternæ Deus, qui etiam Judaicam perfidiam a tua mise-

known strains. The "Reproaches" are a striking expansion of Micah iii. 3, 4, in which the loving-kindness of the Lord is contrasted with the ingratitude of those whom He came to save, carrying the idea through each step of the Passion. The following are the versicles used: the responses also being indicated. After the first three versicles was sung, "Holy God, Holy and Mighty, Holy and Immortal; have mercy upon us;" and after the others, "O My people . . . answer unto Me," much as the Invitatory to the Venite was sung.

O My people, what have I done unto thee, and wherein have I wearied thee? answer unto Me. For I brought thee up out of the land of Egypt, and thou hast prepared the cross for thy Saviour. [Trisagion.]

I led thee forty years in the wilderness, and fed thee with manna, and brought thee into a goodly land. [Trisagion.]

What more could I have done unto thee that I have not done? I planted thee indeed My choicest Vine, and thou art become bitter unto Me; for thou hast given Me vinegar to drink, and hast pierced the side of thy Saviour. [Trisagion.]

For thy sake did I scourge Egypt with its first-born, and thou didst deliver up Me to be scourged. [O My people . . .]

I led thee forth out of Egypt, and drowned Pharaoh in the Red Sea, and thou didst deliver up Me to the chief priests. [O My people . . .]

I opened the sea before thee, and thou hast opened My side with a spear. [O My people . . .]

I went before thee to lead thee in a cloudy pillar, and thou didst lead Me into the hall of Pilate. [O My people . . .]

I fed thee with manna in the wilderness, and thou didst fall upon Me with scourgings and buffetings. [O My people . . .]

I gave thee to drink living water out of the Rock, and thou didst give Me gall and vinegar. [O My people . . .]

For thy sake did I smite the kings of the Canaanites, and thou didst smite Me on the head with a reed. [O My people . . .]

I gave thee a royal sceptre, and thou gavest to My head a crown of thorns. [O My people . . .]

I lifted thee up in great strength, and thou didst lift Me up to hang upon the Cross. [O My people . . .]

During this ceremony the red copes, and chasuble which were worn in the other offices of the day were set aside, and black copes alone were used; the utmost aspect of sorrow and mourning for sin being, at the same time, thrown over the church and all the *instrumenta* of Divine Service, by means of black hangings, a custom which has never been discontinued.

It is a very ancient practice of the Church to abstain from celebrating the Holy Communion on Good Friday. On Maundy Thursday (as has been already shown) a portion of the Sacra-

ment then consecrated was reserved in one element only, and this being placed in a chalice of unconsecrated wine on Good Friday, was then received by those who communicated instead of elements consecrated on the day itself. This Mass of the Pre-sanctified is an institution of very ancient date, being found in the Sacramentaries from which our modern offices are so largely derived: and since it is traceable, on good evidence, as far back as the time of St. Augustine, it seems to represent the practice of the Primitive Church. The use of this office has been general in the Western Church for the greater part of the time of its existence. In the Eastern Church there is no recognition of the Eucharist at all on this day¹, there being in fact almost a total absence of prayer altogether, the services consisting chiefly of the reading of prophecies and gospels respecting the Passion: and such appears also to be the practice of the Ambrosian Rite.

But, although this custom appears to be of primitive origin, it has not been preserved in its primitive form. In the Church of England before the Reformation the practice had grown up of the priest alone receiving on Good Friday the holy Sacrament which had been consecrated on Maundy Thursday; and this is still the practice of the Latin Church. The Sacramentary of St. Gregory clearly indicates that in the early Church others communicated with him as on other days. The rubric directs, "Cum dixerint Amen, sumit de sancta, et ponit in calicem, nihil diversum. *Et communicant omnes cum silentio, et expleta sunt universa.*" [Menard's ed. p. 70.] In the tenth century a Canon of the Church of England which enjoins the reservation on Holy Thursday and certain ceremonies to be used on Good Friday, adds respecting the latter day, "Then let him," i. e. the priest, "go to housel, and whosoever else pleases." [Johnson's Canons, i. 404.] In fact, Martene proves that Communion of the Laity as well as of the priest on this day was the prevailing custom of the Church until the tenth century at least; and there are strong grounds for believing that the practice continued down to the time of the Reformation.

The exact intention of the English rite is not easy to ascertain. The appointment of an Epistle and Gospel is (under the circumstances in which the Prayer Book was set forth) a *prima facie* evidence that Consecration on Good Friday was intended to supersede the Mass of the Pre-sanctified which had been hitherto used; and Communion was, of course, intended to follow. On the other hand, this was a deviation from the ancient practice of the Church, which was not in accordance with the respect for it shown by those who set forth our first English Prayer Book. Such a deviation can only be accounted for by supposing that

¹ No consecration of the Holy Eucharist is allowed during Lent in the Eastern Church except on Saturday and Sunday. The feast of the Annunciation is the only exception to this rule. Communicants on all other days receive the pre-sanctified elements.

they may be saved among the remnant of the true Israelites, and be made one fold under one Shepherd, Jesus Christ our Lord, who liveth and reigneth with thee and the Holy Spirit, one God, world without end. *Amen.*

ricordia non repellis: exaudi preces nostras quas pro illius populi obsecratione deferimus; ut agnita veritatis tuæ luce quæ Christus est, a suis tenebris eruatur. Per eundem Dominum nostrum.

Pro Paganis. Oratio [ix.].

Salisbury Use.

Omnipotens sempiterne Deus, qui non vis mortem peccatorum, sed vitam semper inquiris, suscipe propitius orationem nostram; et libera eos ab idolorum cultura; et aggrega ecclesiæ tuæ sanctæ ad laudem et gloriam nominis tui. Per Dominum.

Greg. Gelas. ut supra.

	<i>Modern English.</i>	<i>Salisbury Use.</i>	<i>Modern Roman.</i>	<i>Eastern.</i>
EPISTLE	Heb. x. 1—25.	{ Hosea v. 15. vi. 6. Exod. xii. 11.	{ Hosea vi. 1—6. Exod. xii. 1—11.	
GOSPEL.	John xix. 1—37.	John xviii. and xix.	John xviii. and xix.	

EASTER EVEN.

The Collect.

[A.D. 1661.]
Rom. vi. 8—5. 10
—12.
Col. iii. 3. 5.
Tit. ii. 11—14.
1 Cor. xv. 21, 22.
Ps. ix. 13.
John vi. 39.
Rom. xiv. 9.

GRANT, O Lord, that as we are baptized into the death of thy blessed Son our Saviour Jesus Christ, so by continual mortifying our corrupt affections we may be buried with him; and that through the grave, and gate of death, we may pass to our joyful resurrection; for his merits, who died, and was buried, and rose again for us, thy Son Jesus Christ our Lord. *Amen.*

VIGILIA PASCHÆ.

Salisbury Use.

[. . . . Resuscitet vos de vitiorum sepulchris, qui Eum resuscitavit a mortuis. Amen. Ut eum Eo sine fine feliciter vivatis quem resurrexisse a mortuis veraciter creditis. Amen.]

[Greg. Benedictio in Dom. I. post Pasch. Oct.]

[O MOST gracious God, look upon us in mercy, and grant that as we are baptized into the death of thy Son our Saviour Jesus Christ; so by

[A.D. 1637.]

strong reasons against reservation were present to the Reformers, but that, at the same time, they did not contemplate depriving the Church of Christ's Sacramental Presence on this Holy Day, and therefore enjoined the ordinary service with consecration.

The practice of the Church of England since the Reformation certainly seems to have been to celebrate the Holy Communion on this day. On Good Friday in 1564 [March 31] Queen Elizabeth openly thanked one of her preachers in her Chapel for his sermon in defence of the Real Presence, which seems to show that the Holy Eucharist was then celebrated. [Heylin's Ref. ii. 317. Eccl. Hist. Soc. ed.] And in Bishop Andrewes' Sermons on the Passion there are allusions to it, which put the matter beyond a doubt.

The conclusions that may be drawn are, (1) that the Church of England never intended so far to depart from ancient habits as to be without the Sacramental Presence of Christ on the Day when His Sacrifice is more vividly brought to mind than on any other day in the year: (2) that from the introduction of the un-Catholic custom of Communion by the priest alone, or for some other reason, it was thought best to disuse the Mass of the Pre-sanctified and substitute Consecration: (3) that it is a less evil to depart from ancient usage by consecrating on this day than to be without the Sacramental Presence of our Lord.

EASTER EVE.

The day between Good Friday and Easter Day commemorates the Descent of our Blessed Lord's soul into Hell, and the rest of His body in the grave. In the Gospel we are told that this

Sabbath day was "an high day" in the Jewish ritual. It was the day when all were to be present before the Lord [Exod. xxiii. 17], and when the sheaf of the first-fruits was to be offered. [Lev. xxiii. 10, 11.] In the Christian Church it at once acquired the name of the "Great Sabbath," being so called in the Epistle of the Church of Smyrna respecting the martyrdom of St. Polycarp. The ancient Epistle and Gospel referred to Holy Baptism, and to our Lord's Resurrection: those now appointed were introduced into the Prayer Book of 1549. The ancient Collect was, "O God, who didst illuminate this most holy night by the glory of our Lord's resurrection; preserve in Thy new-born family the spirit of adoption which Thou hast given: that being renewed both in body and mind, they may render unto Thee a pure service, through the same our Lord." This was not adopted in the translated Offices of the Church (probably because it had some reference to the blessing of the new fire and the Paschal candle); nor was any Collect provided for the day until 1637, when that printed above was inserted in the Prayer Book prepared for Scotland. This is thought to have been the composition of Archbishop Laud, and was the foundation of the present Collect, which is first found in Cosin's writing in the margin of the Durham book. Even this modern Collect keeps up a memorial of the primitive custom of the Church in administering Baptism on Easter Eve. But the practice having fallen into disuse¹, the devotional tone of the day is brought into a more

¹ A Preface to the Baptismal Offices, which was erased from the Prayer

our true and hearty repentance all our sins may be buried with him, and we not fear the grave; that as Christ was raised up from the dead by the glory of thee, O Father, so we also may walk in newness of life, but our sins never be able to rise in judgment against us; and that for the merit of Jesus Christ, that died, was buried, and rose again for us. *Amen.*]

	<i>Modern English.</i>	<i>Salisbury Use.</i>	<i>Modern Roman.</i>	<i>Eastern.</i>
EPISTLE.	1 Pet. iii. 17—22.	Col. iii. 1—4.	Col. iii. 1—4.	Rom. vi. 3—11.
GOSPEL.	Matt. xxvii. 57—66.	Matt. xxviii. 1—7.	Matt. xxviii. 1—7.	Matt. xxviii.

EASTER DAY.

¶ *At Morning Prayer, instead of the Psalm, O come, let us sing, &c., these Anthems shall be sung or said.*

1 Cor. v. 7, 8. **C**HRI^ST our passover is sacrificed for us: therefore let us keep the feast. Not with the old leaven, nor with the leaven of malice and wickedness: but with the unleavened bread of sincerity and truth.

Rom. vi. 9—11. **C**HRI^ST being raised from the dead dieth no more: death hath no more dominion over him. For in that he died, he died unto sin once:

IN DIE PASCHÆ.

¶ *Statio et ordo processionis in die Paschæ Salisbury Use. ante matutinas cum cruce. Pulsatis omnibus campanis cantetur antiphona.*

[*Communio.*

PASCHA nostrum immolatus est Christus: Alleluia. Itaque epulemur, in azymis sinceritatis et veritatis. Alleluia, Alleluia, Alleluia.]

CHRI^STUS resurgens ex mortuis jam non moritur: mors illa ultra non dominabitur. Quod enim mortuus est, peccata mortuus est semel: quod

direct and close analogy with the Holy Week history of our Blessed Lord by the commemoration of His burial, in the Gospel, and His Descent into Hell, in the Epistle. [See notes to the Apostles' Creed.]

The Vigil of Easter has always been celebrated with much ceremony, even from primitive times. It is mentioned by Tertullian [Ad Uxorem ii. 4], and in the Apostolical Constitutions [v. 20], by Busebius [vi. 9], Lactantius [vii. 19], St. Chrysostom, and St. Jerome. St. Gregory Nazianzen [Orat. xlv. in Pasch.] speaks of the churches being so lighted up that it seemed like day, and this he speaks of as a symbolical usage, (in the spirit of the ancient Collect given above,) memorializing the glorious illumination brought on the world by the Resurrection of the Sun of Righteousness. The services continued until after midnight, to welcome the early dawn of the Resurrection; and also from a tradition (current among the Jews as well) that the second coming of Christ will be in the night of Easter Eve¹. At a later period, and in the ancient offices of the English Church, the new fire, the Paschal candle, and the incense, all received Benediction on this day for use in the succeeding year.

Book in 1661, began: "It appeareth by ancient writers, that the sacrament of Baptism in the old time was not commonly ministered but at two times in the year, at Easter and Whitsuntide; . . . which custom (now being grown out of use), although it cannot," &c. [See notes to Baptism.]

¹ "Hæc est nox, quæ nobis propter adventum regis, ac Dei nostri per-vigilio celebratur: cuius noctis duplex ratio est, quod in ea et vitam tum recepit, cum passus est; et postea orbis terræ regnum recepturus est. Hic est enim Liberato, et Judex, et Ulcor, et Rex, et Deus, quem nos Christum vocamus."—Lactant. vii. 19.

There has ever been something of festive gladness in the celebration of Easter Eve, which sets it apart from Lent, notwithstanding the fast still continues. To the disciples it was a day of mourning after an absent Lord; but the Church of the Resurrection sees already the triumph of that Lord over Satan and Death. In the promise of the prophetic words, "I will ransom them from the power of the grave; I will redeem them from death: O death, I will be thy plagues; O grave, I will be thy destruction" [Hos. xiii. 14], she sees afar off the dawn of the Resurrection, and already the words sound in her ears, "Your sorrow shall be turned into joy." A celebration of the Holy Communion took place on this day, as on Maundy Thursday, at the time of Vespers; and in the place of the Introit was sung *Gloria in Excelsis Deo*, with its response, *Et in terra pax hominibus*, while the bells of the church were ringing in the joys of Easter². At Milan, "Ad Missam in ecclesia majore," the announcement of our Lord's Resurrection was thrice made in the words, "Christus Dominus resurrexit," when the response thrice followed, "Deo gratias."

EASTER DAY.

They who went about "preaching Jesus and the Resurrection," and who observed the first day of the week as a continual memorial of that Resurrection, must have remembered with vivid and joyous devotion the anniversary of their Lord's restoration to them. It was kept as the principal festival of the year, therefore, in the very first age of the Church, and Easter had become

² This custom is observed on Christmas Eve at Magdalen College, Oxford.

but in that he liveth, he liveth unto God. Likewise reckon ye also yourselves to be dead indeed unto sin ; but alive unto God through Jesus Christ our Lord.

1 Cor. xv. 20
—22.

CHRISt is risen from the dead ; and become the first-fruits of them that slept. For since by man came death ; by man came also the resurrection of the dead. For as in Adam all die ; even so in Christ shall all be made alive.

Glory be to the Father, and to the Son ; and to the Holy Ghost ;

Answer.

As it was in the beginning, is now, and ever shall be ; world without end.
Amen.

The Collect.

Acts ii. 24.
John xi. 25.
1 Pet. i. 3.
Heb. ii. 14, 15.
1 Cor. xv. 57, 23.

ALMIGHTY God, who through thine only-begotten Son Jesus Christ hast overcome death, and opened

autem vivit, vivit Deo. Alleluia, Alleluia.

Oratio.

DEUS, qui hodierna die per unigenitum tuum æternitatis nobis aditum, devicta morte, reserasti ; vota

Salisbury Use.
Greg. Gelas. in
die Sancto
Paschæ. Cf.
Præf. in Dom.
i. post Asc.
Domini ' per

long familiar to all parts of the Christian world so early as the days of Polycarp and Anicetus, who had a consultation at Rome in A.D. 158, as to whether it should be observed according to the reckoning of Jewish or Gentile Christians. [Irenæus in Euseb. v. 24.] Eusebius also records the fact that Melitus, Bishop of Sardis about the same time, wrote two books on the Paschal festival [Euseb. iv. 26], and Tertullian speaks of it as annually celebrated, and the most solemn day for Baptism. [De Jejun. 14. De Bapt. 19.] Cyprian, in one of his Epistles, mentions the celebration of Easter solemnities [lvii.]; and in writers of later date, the festival is constantly referred to as the "most holy Feast," "the great Day" [Conc. Ancyra vi.], the Feast of Feasts, the Great Lord's Day, and the Queen of Festivals. [Greg. Naz. Orat. in Pasch.]

The original name of the Festival was one which also included Good Friday, Πάσχα, which was derived from the Aramaic form of the Hebrew name for Passover. This name was also retained in the Latin : and in the time of Leo the Great, when the distinction began to be made of the Pascha Dominicæ Passionis, and the Pascha Dominicæ Resurrectionis, Dies Paschæ began to be understood chiefly, and soon alone, of Easter. In England the same name was also once familiar, perhaps derived from the French language, and Easter eggs are still called "pasque" [or in a corrupt form "paste"] eggs all over the North of England. The more familiar name of Easter is, however, traceable as far back as the time of the Venerable Bede, who derives it from the name of a pagan goddess Eostre, or Ostera, whose festival happened about the time of the vernal equinox [De ratione Temporum, xiii.], and was observed as a time of general sacrifices, with a view to a good harvest. Later, and perhaps more trustworthy philologists have derived the word from the old Teutonic *urstan*, to rise, and *urstand*, the Resurrection : and it is significant that the idea of sunrise is self-evident in the English name of the Festival on which the Sun of Righteousness arose from the darkness of the grave. The popular name for the day among Oriental Christians, is *Acumrpd*, the Bright Day, in which the same idea is

to be observed. In old English Calendars Easter is called "the uprising of our Lord," and "the Aænrysing of our Lord."

The Judaizing habits which caused so much trouble in the earliest days of Christianity, long retained a hold upon many portions of the Church in respect to the observance of Easter. In the Western Church the festival was always kept on the first day of the week, as being the actual day which our Lord had consecrated by His Resurrection ; but the Churches of Asia kept it on the third day after the 14th of the Jewish month Nisan, whatever day of the week this might be. In the second and third centuries there was much controversy respecting this difference of computation ; but the first Canon of the Council of Arles [A.D. 314] ordered Easter to be celebrated on one day every where, and the Council of Nicæa [A.D. 325] authoritatively ruled that Easter was to be kept on the Lord's Day¹. There being also much difficulty in determining, without scientific help, which Sunday in March or April was the proper one, the same Council directed that the Church of Alexandria should send timely notice to other principal Churches of the day on which the true Easter would occur in the ensuing year, and that thus a uniform practice should be maintained throughout the Christian world². It was not, however, until the eighth century that the computation of Easter was settled on sufficiently accurate calculations to ensure uniformity³; and the Church of England retained, for some ages, a modified form of the Jewish method, which was

¹ There is no Canon of this Council on the subject, but that its decision was authoritative may be certainly inferred from the manner in which it is recorded in Theodoret i. 9, 10, Socrates i. 9, and Euseb., Life of Constantine, iii. 18.

² There is a relic of this practice in the Ambrosian Rite, where the following proclamation of Easter is directed to be made on the feast of the Epiphany :—

"Annunciatio diei Paschatis per Diaconum.

"Noverit charitas vestra, fratres charissimi, quod annuente Dei et Domini nostri Jesu Christi misericordia, die tali mensis talis Pascha Domini celebrabitur."

³ See note on the "Tables to find Easter."

Phil. i. 6. ii. 13.
Heb. xiii. 20, 21.

unto us the gate of everlasting life; We humbly beseech thee, that, as by thy special grace preventing us thou dost put into our minds good desires, so by thy continual help we may bring the same to good effect; through Jesus Christ our Lord, who liveth and reigneth with thee and the Holy Ghost, ever one God, world without end. *Amen.*

nostra, quæ præveniēdo aspiras, etiam adjuvando prosequere, Per eundem Dominum nostrum Jesum Christum Filium tuum. Qui tecum.

gloriam Resurrectionis vitæ æternæ aditum patefecit.

	<i>Modern English.</i>	<i>Salisbury Use.</i>	<i>Modern Roman.</i>	<i>Eastern.</i>
EPISTLE.	Col. iii. 1—7.	1 Cor. v. 7, 8.	1 Cor. v. 7, 8.	Acts i. 1—8.
GOSPEL.	John xx. 1—10.	Mark xvi. 1—7.	Mark xvi. 1—7.	John i. 1—17.

MONDAY IN EASTER WEEK.

The Collect.

[A.D. 1549.]

ALMIGHTY God, who through thy only-begotten Son Jesus Christ hast overcome death, and opened unto us the gate of everlasting life; We humbly beseech thee, that, as by

FERIA II., POST PASCHA.

Salisbury Use.

not wholly banished from the Northern parts of the island until A.D. 714. These two methods of computing Easter may be shortly explained by adding that the Jewish or "Quartodeciman" computation aimed at observing the very day of our Lord's Resurrection (as we observe the day of His Nativity); while the method which ultimately became universal aims at observing that Lord's Day as Easter which comes next after the actual anniversary. Each method claimed Apostolic authority from the first: Polycarp, who advocated the Jewish system, declared that it was derived from St. John, with whom he was contemporary; while the Bishops of Rome and others believed themselves to be following a custom handed down to them from St. Peter and St. Paul.

The Anthems instead of "Venite exultemus" represent the primitive custom of Easter morning, when the versicle "The Lord is risen," and the response "He is risen indeed," were the formal salutation between Christians. In the ancient rite of the English Church one of these anthems was said in procession before Mattins; and the service was retained in 1549. It may be useful to the reader to see the Latin and English forms side by side.

Salisbury Use.

Prayer Book of 1549.

¶ *Statio et ordo processionis in die Pasche ante matutinas cum cruce. Pulsatis omnibus campanis cantetur antiphona.*

Christus vivit Deo. Alleluia, Alleluia.

¶ Dicant nunc Judæi quomodo milites custodientes sepulchrum perdidit regem ad lapidis positionem quare non servabant petram justitiæ aut sepultum reddant aut resurgentem adoret nobiscum, dicentes, Alleluia, Alleluia.

¶ Surrexit Dominus de sepulchro.

R. Qui pro nobis pendit in ligno. Alleluia.

¶ *In the morning afore Matins, the people being assembled in the Church, these anthems shall be first solemnly sung or said.*

Christ living unto God in Christ Jesus our Lord. Hallelujah, Hallelujah. Christ is risen again all men shall be restored to life. Hallelujah.

The Priest.

Shew forth to all nations the glory of God.

The Answer.

And among all people His wonderful works.

Oratio.

Let us pray.

Deus, qui pro nobis Filium crucis patibulum subire voluisti, ut inimici a nobis pelleres postestatem: concede nobis famulis tuis ut in resurrectionis ejus gaudiis semper vivamus. Per.

O God, who for our redemption didst give Thine only-begotten Son to the death of the cross; and by His glorious resurrection hast delivered us from the power of our enemy; grant us so to die daily from sin, that we may evermore live with Him in the joy of His resurrection; through the same Christ our Lord. Amen.

The present Rubric substituting these Anthems for the Venite was introduced in 1552¹: they were not pointed in 1549.

In the Salisbury Use there was a celebration at a late hour on Easter Eve, probably after midnight; and in the Prayer Book of 1549 two celebrations are directed for Easter Day, the Collect, Epistle, and Gospel for the first of which are those which are still retained; the Epistle being that previously in use on Easter Eve. The second celebration had the Collect which is now used (as it then was also) for the Octave of Easter Day, and the Epistle and Gospel of the ancient Missal.

INTROIT.—When I wake up I am present with Thee. Alleluia. Thou hast laid Thine hand upon me. Alleluia. Such knowledge is too wonderful for me. Alleluia. Alleluia. Ps. O Lord, Thou hast searched me out and proved me. Thou knowest my down-sitting and mine uprising. Glory be.

EASTER MONDAY.

The extension of the Easter festival through seven days is mentioned by St. Chrysostom in one of his Easter homilies, by St. Augustine in one of his Epistles [iv. ad Januar.], and in the Code of Theodosius, which directed a cessation of labour during the whole of the week. The Sacramentary of St. Gregory contains a service for each day, as does also the Salisbury Missal. Yet there are many ancient precedents for the course taken in the later English rite, which limits the special services to three

¹ See note at p. 1.

thy special grace preventing us thou dost put into our minds good desires, so by thy continual help we may bring the same to good effect; through Jesus Christ our Lord, who liveth and reigneth with thee and the Holy Ghost, ever one God, world without end. *Amen.*

	<i>Modern English.</i>	<i>Salisbury Use.</i>	<i>Modern Roman.</i>	<i>Eastern.</i>
EPISTLE.	Acts x. 34—43.	Acts x. 34—43.	Acts x. 37—43.	Acts i. 12—17 and 21—26.
GOSPEL.	Luke xxiv. 13—35.	Luke xxiv. 13—35.	Luke xxiv. 13—35.	John i. 18—28.

TUESDAY IN EASTER WEEK.

The Collect.

ALmighty God, who through thy only-begotten Son Jesus Christ hast overcome death, and opened unto us the gate of everlasting life; We humbly beseech thee, that, as by thy special grace preventing us thou dost put into our minds good desires, so by thy continual help we may bring the same to good effect; through Jesus Christ our Lord, who liveth and reigneth with thee and the Holy Ghost, ever one God, world without end. *Amen.*

FERIA III., POST PASCHA.

Salisbury Use.

	<i>Modern English.</i>	<i>Salisbury Use.</i>	<i>Modern Roman.</i>	<i>Eastern.</i>
EPISTLE.	Acts xiii. 26—41.	Acts xiii. 26—33.	Acts xiii. 26—33.	Acts ii. 14—21.
GOSPEL.	Luke xxiv. 36—48.	Luke xxiv. 36—47.	Luke xxiv. 36—47.	Luke xxiv. 12—35.

THE FIRST SUNDAY AFTER EASTER.

The Collect.

[A.D. 1549.]

1 Cor. xv. 3, 4.
Rom. iv. 24, 25.
1 Cor. v. 7, 8.

ALmighty Father, who hast given thine only Son to die for our sins, and to rise again for our jus-

DOMINICA I., POST PASCHA.

Salisbury Use.

PER Christum Dominum nostrum. Qui innocens pro impiis voluit pati, et pro sceleratis indebite

Præf. antiq.
Dom. in
Palmis, Feria
iv. Pamelius
Liturg. ii. 564.

days. At the Council of Mayence [A.D. 813] a canon was passed which restricted the celebration of Easter to four days. The thirty-seventh Canon of Ælfric [A.D. 957] directs the clergy to charge their people, that they keep the first four days of Easter free from all servile work. A Council of Constance [A.D. 1094] enjoined that Pentecost and Easter should both be celebrated with three festival days; and these *πρῆμεις προθεσµια* are spoken of even by Gregory Thaumaturgus in the third century. There seems, therefore, to have been considerable diversity as to the number of days observed, but a general consent in setting apart several days after Sunday in special honour of the festival of our Lord's Resurrection.

In the margin of his Durham Prayer Book, Bishop Cosin wrote out for use on this day the Collect, "O God, who for our redemption" which had been formerly appointed for the procession before Mattins.

INTROIT.—The Lord hath brought you into a land flowing with milk and honey. Alleluia. Wherefore, let the law of the Lord be ever in your mouth. Alleluia. Ps. O give thanks unto the Lord, for He is gracious, and His mercy endureth for ever. Lord, have mercy upon us. Christ, have mercy upon us. Lord, have mercy upon us. V. Glory to God in the highest. R. On earth peace, good will towards men.

EASTER TUESDAY.

Until 1661, the Collect originally appointed for the second celebration on Easter Day was appointed for use on this day.

INTROIT.—He shall give him the water of wisdom to drink. Alleluia. She shall be established in them, and shall not be moved. Alleluia. And shall exalt them for ever. Alleluia. Alle-

1 John iii. 2, 3.
1 Pet. ii. 1, 2.

tification; Grant us so to put away the leaven of malice and wickedness, that we may alway serve thee in pureness of living and truth; through the merits of the same thy Son Jesus Christ our Lord. *Amen.*

condemnari. Cujus mors delicta nostra detorsit, et resurrectio nobis justificationem exhibuit]

	<i>Modern English.</i>	<i>Salisbury Use.</i>	<i>Modern Roman.</i>	<i>Eastern.</i>
EPISTLE.	1 John v. 4—12.	1 John v. 4—10.	1 John v. 4—10.	Acts v. 12—20.
GOSPEL.	John xx. 19—23.	John xx. 19—31.	John xx. 19—31.	John xx. 19—31.

THE SECOND SUNDAY AFTER EASTER.

DOMINICA II., POST PASCHA.

Salisbury Use.

The Collect.

[A.D. 1549.]

1 Cor. v. 7.
1 Pet. ii. 21, 22.
Eph. v. 1, 2.
Col. i. 12—14.
John xiii. 15.
Heb. xii. 1, 2.

ALMIGHTY God, who hast given thine only Son to be unto us both a sacrifice for sin, and also an ensample of godly life; Give us grace

Inia. Ps. O give thanks unto the Lord, for He is gracious, and His mercy endureth for ever. Glory be.

Thou hast searched me out and proved me. Thou knowest my downsitting and mine uprising. Glory be.

LOW SUNDAY.

HYMNS.

All the days between Easter and its Octave have "in Albis" added to them in the Sacramentary of St. Gregory, but the Sunday after Easter is called Dominica octavas Paschæ. From a very ancient period, however, it has been called "Dominica post albas," or (as in the Ambrosian Missal), "Dominica in albis depositis," and shortly, "Dominica in albis," because on this day the newly baptized first appeared without the chrisoms or white robes which they had worn every day since their baptism on Easter Eve. The popular English name of Low Sunday has probably arisen from the contrast between the joys of Easter and the first return to ordinary Sunday services. On this Sunday, or sometimes on the fourth Sunday after Easter, it was the custom, in primitive days, for those who had been baptized the year before to keep an anniversary of their baptism, which was called the Annotine Easter, although the actual anniversary of the previous Easter might fall on another day. [Micrologus lvi.] The Epistle evidently bears on this custom, and sets forth the new birth of Baptism as the beginning of an abiding power of overcoming the world through its connexion with the Risen Christ, the source of our regeneration. The ancient writer just referred to suggests the reflection, that if we celebrate the anniversary of that day when we were born to eternal death through original sin, how much rather ought we to keep in memory the day when we were new born into eternal life¹?

EVENSONG.—*Chorus nova Hierusalem.* H. N. 25. 56, H. A. M. 106.

COMPLINE.—*Jesu Salvator sæculi.* H. N. 30. 57, H. A. M. 118.

MATTINS.—*Aurora lucis rutilat.* H. N. 26. 58, H. A. M. 109.

LAUDS.—*Sermone blando angelus.* H. N. 27. 59, H. A. M. 109.

EVENSONG.—*Ad cœnam Agni providi.* H. N. 29. 64, H. A. M. 111.

The four last hymns are appointed to be sung daily until Ascension Day. But on all feasts of Apostles and Evangelists during the Paschal Season, the following:—

EVENSONG AND MATTINS.—*Tristes erant Apostoli.* H. N. 37. 77, H. A. M. 109.

LAUDS.—*Claro paschali gaudio.* H. N. 38. 78, H. A. M. 109.

The Collect appointed for this Sunday in 1549 was that now in use, the one originally belonging to the second communion of Easter Day. In 1552, when the special service for this second communion was discontinued, the Collect at present in use on Easter Day was substituted. In both cases Low Sunday was regarded as the Octave of Easter, according to the ancient rite; but in 1661 the original Collect of the day was restored at the suggestion of Cosin, the change that had removed it from use on Easter Day being overlooked, and thus the ritual symmetry of the two services was marred.

THE SECOND SUNDAY AFTER EASTER.

INTROIT.—When I wake up I am present with Thee. Alleluia. Thou hast laid Thine hand upon me. Alleluia. Such knowledge is too wonderful for me. Alleluia. Ps. O Lord,

The Eucharistic tone of the Scriptures used begins now to diverge from the fact of the Resurrection to the results of it, as giving to the Church a Saviour abiding with us for ever. In the Epistle and Gospel He is set forth as the Chief Pastor, the High Priest of the New Dispensation; and His own words, "I am the good Shepherd," are taken up by His chief Apostle when he calls Him "the Shepherd and Bishop of your souls." The Collect is, however, based on the idea of Christ's holy example as referred to in the first part of the Epistle, and neither in the modern nor in the ancient service is there any recognition of the beautiful parable which our Lord spoke of Himself in the Gospel, except that the first words of it were taken for the "Communio," or sentence sung during the communion of the laity. Durandus states that the Epistle and Gospel concerning the sheep and the Shepherd are connected with a Roman custom of holding councils on this day; but if so, the custom must be more ancient than the days of St. Jerome, in whose Lectionary they are found. It seems probable that Christ's example to His pastors is, however, the idea of the Sunday, not His example to all.

In both Epistle and Gospel (considering the season at which they are used) there must be taken to be a reference to victory gained by suffering. The good Shepherd would not win His flock by agreeing to the Tempter's suggestion, "All these things will I give Thee, and the glory of them, if Thou wilt fall down

¹ In the Lectionary of St. Jerome the Pascha Annotinum is set down for the third Saturday after Easter. The Epistle is Rev. v., and the Gospel, John iii.

that we may always most thankfully receive that his inestimable benefit, and also daily endeavour ourselves to follow the blessed steps of his most holy life; through the same Jesus Christ our Lord. *Amen.*

	<i>Modern English.</i>	<i>Salisbury Use.</i>	<i>Modern Roman.</i>	<i>Eastern.</i>
EPISTLE.	1 Pet. ii. 19—25.	1 Pet. ii. 21—25.	1 Pet. ii. 21—25.	Acts vi. 1—7.
GOSPEL.	John x. 11—16.	John x. 11—16.	John x. 11—16.	Mark xv. 43. xvi. 8.

THE THIRD SUNDAY AFTER EASTER.

The Collect.

Isa. xxix. 24.
xxx. 31.
2 Tim. ii. 19.
1 Pet. iii. 10, 11.
Eph. v. 8. 13—15.
1 John i. 3. 6.
Eph. iv. 1.
2 Pet. i. 5—8.

ALMMIGHTY God, who shewest to them that be in error the light of thy truth, to the intent that they may return into the way of righteousness; Grant unto all them that are admitted into the fellowship of Christ's religion, that they may eschew those things that are contrary to their profession, and follow all such things as are agreeable to the same; through our Lord Jesus Christ. *Amen.*

DOMINICA III, POST PASCHA.

Oratio.

DEUS, qui errantibus, ut in viam possint redire justitiæ, veritatis tuæ lumen ostendis; da cunctis qui Christiana professione censentur, et illa respuere, quæ huic inimica sunt nomini, et ea quæ sunt apta sectari. Per Dominum.

Salisbury Use.
Greg. Gelas. Dom.
ii. post Oct.
Paschæ. Leo
in Murat. i.
301.

	<i>Modern English.</i>	<i>Salisbury Use.</i>	<i>Modern Roman.</i>	<i>Eastern.</i>
EPISTLE.	1 Pet. ii. 11—17.	1 Pet. ii. 11—19.	1 Pet. ii. 11—19.	Acts ix. 32—42.
GOSPEL.	John xvi. 16—22.	John xvi. 16—22.	John xvi. 16—22.	John v. 1—15.

and worship me," for that would have been no victory at all: but He won them by giving up His life for them; and the seeming extinction of all hope on Good Friday was the step to that triumph by which the "kingdoms of this world have become the kingdoms of the Lord and of His Christ," the Shepherd and Bishop of our souls. The humble obedience of the Son of Man, "even unto death," has made Him an Example to all ages, the Leader of an innumerable army of saints, and the Fountain of the pastoral and sacerdotal office, by the ministrations of which men are gathered into the one fold of salvation.

INTROIT.—The earth is full of the goodness of the Lord. Alleluia. By the word of the Lord were the heavens made. Alleluia. Alleluia. Ps. Rejoice in the Lord, O ye righteous; for it becometh well the just to be thankful. Glory be.

THE THIRD SUNDAY AFTER EASTER.

On this Sunday the risen Saviour is presented to us as the strength of the regenerate, the Fountain of spiritual ability for all Christians, as well as of pastoral ability for His ministers. For the mystical Presence of Christ is the power by which those who are admitted into the Christian body are able to eschew evil and follow good, and it was this Mystical Presence of which Christ spoke in the words of the Gospel.

During the period which is now being commemorated, the Lord Jesus was seen again by His disciples; and yet they must have been possessed by a conviction that it was not for long, and

that their Master was to be taken away from their head as Elijah was from Elisha. At such a time, and as their faith grew with the Resurrection Life of their Lord, the words He had formerly spoken to them must have recurred to their minds as words which had already been in part fulfilled, and of which a still more glorious fulfilment was in prospect. Because He was going to the Father to present His natural Body as an ever-living Intercession, He could not be seen by the bodily eyes of His little flock; but because He was going to the Father to be a continual Mediator and Intercessor, the benefits of His Presence would be manifestly given to the many, even as if the eyes of all the faithful rested upon His visible Person.

Thus had the good Shepherd comforted His flock before His Death: and thus in the Divine Service of His Church He is ever at this season speaking to us, and bidding us look to Him as a Saviour present in His Church, and to be beheld by the eyes of those who will look for Him in faith. A Presence which Christ could speak of in such terms as those of this day's Gospel may well be called Real, and in such a Presence His people may well look for that strength of the regenerate which will enable them to fulfil the duties of the regenerate.

INTROIT.—O be joyful in God, all ye lands. Alleluia. Sing praises unto the honour of His Name. Alleluia. Make His praise to be glorious. Alleluia. Alleluia. Alleluia. Ps. Say unto God, O how wonderful art Thou in Thy works, through the greatness of Thy power. Glory be.

THE FOURTH SUNDAY AFTER EASTER.

The Collect.

Job xi. 12.
Ecc. ix. 3.
Phil. ii. 13.
i. 9—11.
1 Cor. vii. 31.
Matt. vi. 21.
Heb. vi. 18—20.

O ALMIGHTY God, who alone canst order the unruly wills and affections of sinful men; Grant unto thy people, that they may love the thing which thou commandest, and desire that which thou dost promise; that so, among the sundry and manifold changes of the world, our hearts may surely there be fixed where true joys are to be found; through Jesus Christ our Lord. *Amen.*

DOMINICA IV., POST PASCHA.

Oratio.

DEUS, qui fidelium mentes unius efficit voluntatis, da populis tuis id amare quod præcipis, id desiderare quod promittis, ut inter mundanas varietates ibi nostra fixa sint corda ubi vera sunt gaudia. Per.

Salisbury Use.
Greg. Gelas.
Dom. iii. post
Oct. Paschæ.

	<i>Modern English.</i>	<i>Salisbury Use.</i>	<i>Modern Roman.</i>	<i>Eastern.</i>
EPISTLE.	James i. 17—21.	James i. 17—21.	James i. 17—21.	Acts xi. 19—30.
GOSPEL.	John xvi. 5—14.	John xvi. 5—15.	John xvi. 5—15.	John iv. 5—42.

THE FIFTH SUNDAY AFTER EASTER.

The Collect.

James i. 17.
John xv. 5.
Luke xi. 13.
2 Cor. iii. 5.
Ps. xxv. 9, 10.
Phil. i. 6.

O LORD, from whom all good things do come; Grant to us thy humble servants, that by thy holy inspiration we may think those things that be good, and by thy merciful guiding may perform the same; through our Lord Jesus Christ. *Amen.*

DOMINICA V., POST PASCHA.

Oratio.

DEUS, a quo cuncta bona procedunt; largire supplicibus tuis ut cogitemus te inspirante quæ recta sunt, et te gubernante eadem faciamus. Per Dominum.

Salisbury Use.
Greg. Gelas.
Dom. iv. post
Oct. Paschæ.

	<i>Modern English.</i>	<i>Salisbury Use.</i>	<i>Modern Roman.</i>	<i>Eastern.</i>
EPISTLE.	James i. 22—27.	James i. 22—27.	James i. 22—27.	Acts xvi. 16—34.
GOSPEL.	John xvi. 23—33.	John xvi. 23—33.	John xvi. 23—30.	John ix. 1—38.

THE FOURTH SUNDAY AFTER EASTER.

The Collect for this day originally, i. e. in 1549, stood in English exactly as it stands in the Latin: "Almighty God, which dost make the minds of all faithful men to be of one will" Bishop Cosin altered the latter words to "make all men to be of one mind," but the present form was eventually adopted, and the idea of unity was thus taken out of the Collect. The omission is the more singular, since there is in the Gospel a reference to the Holy Spirit by whom this unity is effected.

The Epistle and Gospel point in the same direction as those of the preceding Sunday, viz. to the good and perfect Gift which would be bestowed upon the Church after, and through, the bodily departure of Christ to heaven. It seemed strange and hard to bear that it should be expedient for Him to go away who had been the Leader and Benefactor of His disciples and all who were willing to receive Him; but He spoke these words to them beforehand that they might be comforted with some foreshadowing of the glory and blessing of the New Dispensation which was to be perfected in His Resurrection and Ascension; and be prepared for perceiving, when the fruit of the Resurrection was ripe for gathering, that the departure of Christ to heaven was a greater gain to them through His mystical Presence than His remaining upon earth could have been. This good and perfect gift, the gift which the Spirit of truth bestows

upon the Church, and through the corporate Church on all its individual members, is therefore set before us as we draw near to Ascension Day as the true reason why all sorrow, because of her Lord's departure, should be banished from the Church. The Comforter will come to bestow the Gift of the Word of God engrafted upon human nature, and in that gift to bestow Light, Truth, and Salvation.

INTROIT.—O sing unto the Lord a new song. Alleluia. For He hath done marvellous things. Alleluia. His righteousness hath He openly showed in the sight of the heathen. Alleluia. Alleluia. Ps. With His own right hand, and with His holy arm, hath He gotten Himself the victory. Glory be.

ROGATION SUNDAY.

The fifth Sunday after Easter being the first day of the week in which the Rogation days occur, has taken its name from them, and is usually called Rogation Sunday. The striking appropriateness of the Gospel, which contains our Lord's words about asking in His Name, seems to indicate that it was either chosen for this day on account of its position with reference to the Rogation days, or that the latter were appointed to be observed on the three days following because the Gospel already distinguished this as the Sunday concerning Asking. Both the

THE ASCENSION-DAY.

The Collect.

Mark xvi. 19.
Acts i. 9.
Ps. xxiv. 7-10.
Matt. vi. 20, 21.
Col. iii. 1-4.
Eph. ii. 4-6. 19.

GRANT, we beseech thee, Almighty God, that like as we do believe thy only-begotten Son our

IN DIE ASCENSIONIS DOMINI.

Oratio.

CONCEDE quæsumus omnipotens Deus, ut qui hodierna die unigenitum tuum Redemptorem nostrum

Salisbury Use.
Greg. in Ascensa Domini.

Epistle and Gospel are found in the Lectionary of St. Jerome, and as the Rogation days are generally said to have been instituted in the fifth century, the latter seems the more probable theory. The Collect has an evident connexion with the purpose of the Rogation days; and so, perhaps, has the latter part of the Epistle. Bishop Cosin wished to insert a new rubric at the end of the Gospel, "This Collect, Epistle, and Gospel shall be used only upon this day."

INTROIT.—With the voice of singing declare ye, declare ye. Alleluia. Utter it even to the end of the earth, say ye that the Lord hath redeemed His people. Alleluia. Alleluia. Ps. O be joyful in the Lord, all ye lands. Sing praises unto the honour of His Name. Make His praise to be glorious. Glory be.

THE ROGATION DAYS.

On the authority of St. Gregory of Tours (who wrote in the latter part of the sixth century) the institution of the Rogation Days is attributed to Mamertus, Bishop of the French diocese of Vienne, A.D. 452. A terrible calamity is said to have occurred to the diocese or city of Vienne (by earthquake and fire, and by the incursion of wolves and other wild beasts), on account of which Mamertus set apart the three days before Ascension Day as a solemn fast, during which processions with Litanies were to be made throughout the diocese. [See Introduction to the Litany.] The custom is supposed to have been taken up by other dioceses, and to have extended itself from France to England, but not to have been recognized at Rome until the eighth or ninth century. A more probable account is that the Rogation days were instituted at some earlier period, for the purpose of asking God's Blessing on the rising produce of the earth; and that Mamertus chose them as the time for a solemn observance in deprecation of God's anger with reference to the special troubles of his day.

There was a Collect, Epistle, and Gospel for the Rogation Days in the Salisbury Missal, but these were not retained in the Prayer Book, although there is a Homily in three parts "for the days of Rogation week¹," and an "Exhortation to be spoken to such Parishes where they use their Perambulations in Rogation week, for the oversight of the bounds and limits of their town." Bishop Cosin proposed to supply this omission, and wrote the following in the margin of the Durham Prayer Book:—

"THE COLLECT."

"Almighty God, Lord of Heaven and Earth, in whom we live, and move, and have our being; who dost good unto all men, making Thy sun to rise on the evil and on the good, and sending rain on the just and on the unjust; favourably behold us. Thy people, who call upon Thy Name, and send us Thy Blessing from heaven in giving us fruitful seasons, and filling our hearts with food and gladness; that both our hearts and mouths may be continually filled with Thy praises, giving thanks to Thee in Thy holy Church through Jesus Christ our Lord. Amen²."

¹ The title of this Homily, "That all good things come from God," seems to be suggested by the Collect for the Sunday.

² This Collect first appears in Cosin's Devotions, originally printed in 1626. It is not quite so rhythmical as some others of his composition, and perhaps the following form of it is better adapted for intonation:—

"Almighty God, Lord of Heaven and Earth, in whom we live, and move, and have our being; who dost cause Thy sun to rise on the evil and on the good, and sendest rain both upon the just and the unjust: we beseech Thee, favourably to behold Thy people who call upon Thee, and send Thy Blessing

A Collect was also proposed by the Commission of 1689, which is worthy of being placed beside that of Bishop Cosin:

"Almighty God, who hast blessed the earth that it should be fruitful, and bring forth every thing that is necessary for the life of man, and hast commanded us to work with quietness and eat our own bread; bless us in all our labours, and grant us such seasonable weather that we may gather in the fruits of the earth, and ever rejoice in Thy goodness, to the praise of Thy holy Name, through Jesus Christ our Lord. Amen."

The following table shows the old Epistles and Gospels for the three days, those proposed by Cosin, and also those suggested by the Commission of 1689. [See also the Table of Proper Psalms.]

	<i>Salisbury Use.</i>	<i>Cosin.</i>	1689.
EPISTLE.	James v. 16-20. Isa. vii. 10-15. Acts iv. 31-35.	James v. 13-18.	Deut. xxviii. 1-9.
GOSPEL.	Luke xi. 5-13. Luke i. 26-38. John xvii. 1-11.	Luke xi. 1-10.	Matt. vi. 25 to the end.

The religious Services of the Rogation Days are not limited to the walls of the Church. From very ancient days "Perambulations" around the boundaries of the parish have been made in procession, and the Litany, or a portion of it, with the 103rd and 104th Psalm sung at various stations, marked by Crosses, or still remembered by the parishioners from generation to generation, even when the crosses have ceased to mark the spots. It is not necessary to occupy space with the details of well-known usages connected with these perambulations, but it may be as well to set before the reader an extract from the Injunctions of Queen Elizabeth, issued in 1559, in which both the secular and the religious purpose of the procession is referred to.

"... For the retaining of the perambulation of the Circuits of Parishes, they shall once in the year at the time accustomed with the Curate and the substantial men of the Parish walk about the Parishes as they were accustomed, and at their return to the Church make their common prayers.

"Provided, that the Curate in their said common Perambulations, used heretofore in the days of Rogations, at certain convenient places, shall admonish the people to give thanks to God, in the beholding of God's benefits, for the increase and abundance of His fruits upon the face of the earth, with the saying of the 103rd Psalm: *Benedic, anima mea, &c.* At which time also the same minister shall inculcate these or such sentences, 'Cursed be he which translateth the bounds and dolles of his neighbour.' Or such other order of prayers, as shall be hereafter appointed."

The "Exhortation" printed as a sequel to the Rogation-day Homily begins by saying that the principal object of the Procession or Perambulation is that of asking God's blessing upon the land and its fruits, and adds, "Yet have we occasion secondarily given us in our walks on these days to consider the old ancient bounds and limits belonging to our township," &c. &c. From Bishops' Articles of Visitation of later periods it appears that the ordinary practice was to use the Litany on each of these days, and a portion of the Homily. But it is clear that there

down from heaven to give us a fruitful season: that both our hearts and mouths being continually filled with Thy goodness, we may evermore give thanks unto Thee in Thy holy Church, through Jesus Christ our Lord. Amen."

In the same volume there is another admirable Collect for the Ember Week in September, which would be a most suitable one to use for a Harvest Thanksgiving Celebration.

Lord Jesus Christ to have ascended into the heavens; so we may also in heart and mind thither ascend, and with him continually dwell, who liveth and reigneth with thee and the Holy Ghost, one God, world without end.
Amen.

ad cœlos ascendisse credimus, ipsi quoque mente in cœlestibus habitemus. Per eundem Dominum nostrum.

	<i>Modern English.</i>	<i>Salisbury Use.</i>	<i>Modern Roman.</i>	<i>Eastern.</i>
EPISTLE.	Acts i. 1—11.	Acts i. 1—11.	Acts i. 1—11.	Acts i. 1—12.
GOSPEL.	Mark xvi. 14—20.	Mark xvi. 14—20.	Mark xvi. 14—20.	Luke xxiv. 36—53.

SUNDAY AFTER ASCENSION-DAY.

**The Collect.*

Ps. xxiv. 7.
Ps. xlvii. 5—8.
Phil. ii. 9—11.
John xiv. 16—18.
1 Pet. i. 3. iii. 22.

O GOD the King of glory, who hast exalted thine only Son Jesus Christ with great triumph unto

DOMINICA INFRA OCTAV. ASCENSIONIS.

Antiph. ad Vesp. in die Ascens.

O REX Gloriæ, Domine virtutum, qui triumphator hodie super omnes cœlos ascendisti, ne derelinquas

was never any settled rule, and that the practice varied according to the piety and liturgical feeling of the day or the parish.

The Rogation Days and the religious observance of them in some such manner as that above indicated are referred to in the most ancient records of the Church of England. In the Laws of King Alfred and of Athelstan they are called *gebeddagas* or Prayer Days, and also *gang dægas*; the latter name, "gang days," being still used in some parts of the north of England.

* HOLY THURSDAY.

There is not any very early historical notice of Ascension Day, but St. Chrysostom has a homily on the day; St. Augustine mentions it in one of his Epistles, and also in a Sermon [261], in which he says, "We celebrate this day the solemnity of the Ascension." St. Gregory of Nyssa has also left a homily on the day. St. Augustine calls this one of the festivals which are supposed to have been instituted by the Apostles themselves [Ep. liv. al. cxviii. ad Januar.], so that it must have been generally observed in his time: and Proclus, Archbishop of Constantinople, in the same age, speaks of it [Orat. iii.] as one of the days which the Lord has made, reverently considering that the great acts of our Lord so far consecrated the days on which they occurred that no further appointment was needed for their separation from common days. Its name has never varied, although popular appellations have, of course, been attached to it on account of some observances connected with the day. But even these have been very few, and are not worth notice, "Holy Thursday" being the only vernacular name that has been generally adopted.

During the Paschal Quinquagesima no festivals have vigils or fasting eves except Ascension Day and Whitsunday, the whole period being regarded as one of spiritual joy in the Resurrection.

The ritual provisions of the Prayer Book for this day show plainly that it is regarded in the system of our Church as one of the very highest class of solemn days set apart in honour of our Lord. The proper Lessons and Psalms at Mattins and Evensong, and the proper preface in the Communion Service place it on the same footing as Christmas Day, Easter, or Whitsunday; and there is no day in the year which is so well illustrated by these as that of the Ascension. It could hardly have been otherwise, for the act which is commemorated on this day was one which crowned and consummated the work of the Redeemer's Person, and opened the gate of everlasting life to those whom He had redeemed.

The facts of the Ascension are commemorated in the Epistle and Gospel; types of it form the subjects of the first lessons at

Mattins and Evensong,—Moses in the mount of God for forty days receiving the law, and Elijah ascending to heaven in a whirlwind. But the fulness of the day's meaning must be looked for in the Psalms, where, as so often, the interpretation of the Gospels was given by God beforehand to the Church. And in these the Church also celebrates the eternal Victory of the King of glory, who had been made a little lower than the angels in the humiliation of His earthly life, that He might be crowned with the glory and worship of all created things, when seated, still in His human nature, on the throne of Heaven. The festival concludes the yearly commemoration of our Blessed Lord's life and work: which thus leads upward from the cradle at Bethlehem, exhibiting before God and man the various stages of His redeeming work, and following Him step by step until we stand with the disciples gazing up after Him as He goes within the everlasting doors. And thus this half-yearly cycle of days presents the holy Jesus to our devotions as perfect Man and perfect God, the perfection of His manhood confirmed in the sorrows of Good Friday, the perfection of His Divine Nature in the triumph of Easter and the Ascension.

INTROIT.—Ye men of Galilee, why stand ye gazing up into heaven? Alleluia. So shall He come as ye have seen Him go into heaven. Alleluia. Alleluia. Alleluia. Ps. And while they looked stedfastly toward heaven as He went up, behold two men stood by them in white apparel, which said. Glory be.

HYMNS.

EVENSONG AND MATTINS.—*Æterne Rex altissime.* H. N. 31. 66, H. A. M. 122.

COMPLINE.—*Jesu, nostra Redemptio.* H. N. 32. 67, H. A. M. 125.

LAUDS.—*Tu, Christe, nostrum gaudium* [partly H. A. M. 129].

These hymns are appointed to be sung daily up to Whitsunday.

SUNDAY AFTER ASCENSION.

This day was anciently called by the significant name of "Dominica Expectationis." Being the only Lord's Day which intervened between the Ascension of our Lord and the Descent of the Holy Ghost, it represents that period during which the Apostles were obeying the command of their Master, when "He commanded them that they should not depart from Jerusalem, but wait for the promise of the Father." [Acts i. 4.]

The Collect for this day is an expansion of the ancient Anti-

Rom. xv. 13.
Heb. vi. 17—20.
John xiv. 18,
marg. "orphans."
phans."

thy kingdom in heaven; We beseech thee, leave us not comfortless; but send to us thine Holy Ghost to comfort us, and exalt us unto the same place whither our Saviour Christ is gone before, who liveth and reigneth with thee and the Holy Ghost, one God, world without end. *Amen.*

nos orphanos, sed mitte promissum Patris in nos Spiritum veritatis. Alleluia.

[Omnipotens Deus Pater gloriæ, qui Dominum nostrum Jesum Christum suscitasti a mortuis, conlocans illum ad dexteram tuam super omnem principatum et potestatem, &c.] *Mozarabic [Brev.].*

	<i>Modern English.</i>	<i>Salisbury Use.</i>	<i>Modern Roman.</i>	<i>Eastern.</i>
EPISTLE.	1 Pet. iv. 7—11.	1 Pet. iv. 7—11.	1 Pet. iv. 7—11.	Acts xx. 16—36.
GOSPEL.	John xv. 26. xvi. 4.	John xv. 26. xvi. 4.	John xv. 26. xvi. 4.	John xvii. 1—13.

WHITSUNDAY.

The Collect.

John xiv. 26.
Acts ii. 1—4, 6, 16, 17.
Phil. i. 9, 10.
Eph. i. 15, 19.
Acts ix. 31.
Phil. ii. 1, 2.

GOD, who as at this time didst teach the hearts of thy faithful people by the sending to them the light of thy Holy Spirit; Grant us by the same Spirit to have a right judgment in all things, and evermore to rejoice in his holy comfort; through the merits of Christ Jesus our Saviour, who liveth and reigneth with thee, in the unity of the same Spirit, one God, world without end. *Amen.*

IN DIE PENTECOSTES.

Oratio.

DEUS, qui hodierna die corda fidelium Sancti Spiritus illustratione docuisti; da nobis in eodem Spiritu, recta sapere, et de ejus semper consolatione gaudere. Per Dominum nostrum. In unitate ejusdem. *Salisbury Use. Greg. die Sancto Pentecostes.*

	<i>Modern English.</i>	<i>Salisbury Use.</i>	<i>Modern Roman.</i>	<i>Eastern.</i>
EPISTLE.	Acts ii. 1—11.	Acts x. 34—47.	Acts x. 34—47.	Acts ii. 1—11.
GOSPEL.	John xiv. 15—31.	John xiv. 15—31.	John xiv. 23—31.	John vii. 37—53. viii. 12.

phon to the Magnificat on Ascension Day; and has a special interest in the English Church from the fact recorded in the account of the Venerable Bede's death, that it was among the last of the words which he uttered. He died on the Wednesday evening about the time of the first Vespers of the Festival, and the spirit in which he sang the Antiphon is well expressed by the aspiration that concludes the modern Collect.

The day itself, within the octave of the Ascension, may be properly considered as a continuation of that festival, but commemorating especially the session of our Lord at the right hand of the Father.

INTROIT.—Hearken unto my voice, O Lord, when I cry unto Thee. Alleluia. My heart hath talked of Thee, Seek ye My face. Thy face will I seek. O hide not Thou Thy face from me. Alleluia. Alleluia. Ps. The Lord is my light and my salvation, whom then shall I fear? Glory be.

WHITSUNDAY

This great festival commemorates the descent of the Holy Ghost upon the Apostles to abide in the Church for ever, according to the promise of Christ. It has been annually observed from the very beginning, having at first been engrafted by the Jewish Christians on to the festival of Pentecost, but being mentioned as a separate feast of the Church by the earliest writers among the Gentile Christians, as Irenæus [Fragm. de Pasch.

in Justin Mart.] and Tertullian [de Coron. 3, de Idol. 14, de Bapt. 19, de Orat. 23], the latter of whom leaves it on record in several places that this was one of the principal times for Baptism in the early Church. Origen also names it in his work against Celsus. [viii.]

The original name of the festival was derived from that given by Greek writers in the Septuagint and in the New Testament to the Jewish feast, and has precisely the same meaning as Quinquagesima, Pentecost being the *fiftieth day* from the morrow of the Passover Sabbath. The English name is supposed by many to be properly Whitsun Day, not Whit Sunday, and to be identical with the name Pentecost through the German Pfingsten. Most old writers on the festivals of the English Church have, however, considered that the original name was White Sunday or Wit Sunday; in the one case deriving it from the chrismos of the newly baptized; and in the other, from the outpouring of wisdom (or, in old English, "wit") upon the Church by the Holy Ghost on this day. In the Table of Proper Psalms it is spelt Whit Sunday, but nowhere else in the Prayer Book.

The original feast of Pentecost was instituted by God (as it is supposed) as a memorial of the day on which He gave the law to Moses, and declared the Israelites "a peculiar treasure, a kingdom of priests, and an holy nation." [Exod. xix. 5, 6.] But the prominent character of the day was that of a solemn harvest festival. On the morrow of the Passover Sabbath, fifty days before, the first cut sheaf of corn was offered to God, waved

MONDAY IN WHITSUN WEEK.

The Collect.

GOD, who as at this time didst teach the hearts of thy faithful people, by the sending to them the light of thy Holy Spirit; Grant us by the same Spirit to have a right judgment in all things, and evermore to rejoice in his holy comfort; through the merits of Christ Jesus our Saviour, who liveth and reigneth with thee, in the unity of the same Spirit, one God, world without end. *Amen.*

FERIA II, POST PENTECOSTEN.

Salisbury Use.

[**G**OD, that tauȝtist the hertis of thi feithful seruantis bi the liȝtnynge of the hooli goost: graunte us to saoure riȝtful thingis in the same goost, and to be ioiful euermore of his counfort. Bi crist our lorde. So be it.] [XIVth century Prymer Version.]

	<i>Modern English.</i>	<i>Salisbury Use.</i>	<i>Modern Roman.</i>	<i>Eastern.</i>
EPISTLE.	Acts x. 34—48.	Acts x. 34—47.	Acts x. 42—48.	Eph. v. 8—19.
GOSPEL.	John iii. 16—21.	John iii. 16—21.	John iii. 16—21.	Matt. xviii. 10—20.

TUESDAY IN WHITSUN WEEK.

The Collect.

GOD, who as at this time didst teach the hearts of thy faithful people, by the sending to them the

FERIA III, POST PENTECOSTEN.

Salisbury Use.

before the altar, with supplication for a blessing on the harvest then commenced. On the day of Pentecost two loaves of the first bread made from the new corn were offered (with appointed burnt-offerings), in thanksgiving for the harvest now ended. Each of these objects of the festival has a significant typical application. It was on this day that the Holy Ghost descended to sanctify a new Israel, that they too might be "a chosen generation, a royal priesthood, a holy nation, a peculiar people" [1 Pet. ii. 9]; and this separation of a new Israel from the world began to be made when three thousand were added to the Church by Baptism on the day of Pentecost. On this day also the "Corn of Wheat" (which had fallen into the ground and died on the day of the Passover, and had sprung up a new and perpetual sacrifice to God on Easter Day) sent forth the Holy Spirit to make those five thousand the "One Bread" [1 Cor. x. 17] of the Lord's mystical Body, a first-fruits offering to God of the Church which had been purchased with His Blood.

The Collect for Whitsunday was formerly used every day at Lauds, and was translated into English at least a century and a half before the Prayer Book was set forth. It appears in all the English Prymers which preceded the Prayer Book, and the ancient version given on Whitsun Monday seems to have furnished some phrases to the translation now in use on this day.

Whitsun week is one of the canonical Ember seasons, the summer Ordinations taking place on Trinity Sunday.

On Whitsunday (June 9th), in the year of our Lord 1549, the Book of Common Prayer in English was first used instead of the Latin offices. That day was doubtless chosen (for copies were printed and ready some time before) as a devout acknowledgment that the Holy Ghost was with the Church of England in the important step then taken. May He ever preserve these devotional offices from the attacks of enmity or unwisdom, and continue them in that line of Catholic unity wherein He has guided the Church hitherto to keep them.

INTROIT.—The Spirit of the Lord filleth the world. Alleluia. And that which containeth all things hath knowledge of the voice. Alleluia. Alleluia. Alleluia. Ps. Let God arise, and let His enemies be scattered; let them also that hate Him flee before Him. Glory be.

HYMNS.

EVENSONG AND MATTINS.—*Jam Christus astra ascenderit.* H. N. 83. 69, H. A. M. 129.

LAUDS.—*Impleta gaudent viscera* [partly H. A. M. 129].

TYRCE.—*Veni, Creator Spiritus.* H. A. M. 211. 127.

EVENSONG.—*Beata vobis gaudia.* H. N. 83. 70.

COMPLINE.—*Alma chorus Domini.*

This last hymn is only to be sung on Whitsunday, and the two following days: the rest are sung daily through the week.

WHITSUN MONDAY.

In the Epistle and Gospel for this day we find a trace of the primitive custom of Baptism at Whitsuntide; the one narrating the baptism of Cornelius and his household, and the other referring to that enlightenment by Christ from which the sacrament of Baptism took one of its most primitive names, that of "Illumination." This still serves to point out a purpose in the extension of the Festival. For the Holy Ghost came into the Church not only to inspire the Apostles for their work, which was to be but for a generation, but also to abide with the Church in a perpetual Ministry derived from those Apostles, and a continual ministrations of the gift of grace by their means. Hence the days following Whitsunday are a memorial of that abiding of the Comforter which our Lord promised, that He might be "the Giver of Life" to the world, in the bestowal of union with Christ by Baptism, Confirmation, and the Holy Communion.

INTROIT.—He fed them also with the finest wheat flour. Alleluia. And with honey out of the stony rock should I have satisfied thee. Alleluia. Alleluia. Alleluia. Ps. Sing we merrily unto God our strength: make a cheerful noise unto the God of Jacob. Glory be.

WHITSUN TUESDAY.

On the Tuesday of Whitsun Week there is a reference to another work of the Holy Ghost, that of Confirmation, the Epistle narrating the confirmation of the first Samaritan Christians by the Apostles Peter and John, after they had been converted and baptized by the Deacon Philip. In primitive times Confirmation

light of thy Holy Spirit; Grant us by the same Spirit to have a right judgment in all things, and evermore to rejoice in his holy comfort; through the merits of Christ Jesus our Saviour, who liveth and reigneth with thee, in the unity of the same Spirit, one God, world without end. *Amen.*

	<i>Modern English.</i>	<i>Salisbury Use.</i>	<i>Modern Roman.</i>	<i>Eastern.</i>
EPISTLE.	Acts viii. 14—17.	Acts viii. 14—17.	Acts viii. 14—17.	Rom. i. 7. 13—17.
GOSPEL.	John x. 1—10.	John x. 1—10.	John x. 1—10.	Matt. iv. 23. v. 13.

TRINITY SUNDAY.

The Collect.

Rom. x. 9—11.
Matt. iii. 16, 17.
xxviii. 19.
2 Cor. xiii. 14.
1 John v. 7.
Isa. vi. 3.

ALMIGHTY and everlasting God, who hast given unto us thy servants grace by the confession of a true

IN DIE SANCTÆ TRINITATIS.

Oratio.

OMNIPOTENS sempiternæ Deus, qui dedisti famulis tuis, in confessione veræ fidei æternæ Trinitatis

Salisbury Use.
Greg. Dom. Oct.
Pentecost.

was administered immediately after Baptism, if a Bishop was present, as was mostly the case, and at Whitsuntide it would no doubt be invariably given to the newly baptized at once, from the appropriateness of the season, and the necessary presence of the Bishops in their chief Churches for the Ordinations of the following Saturday or Sunday.

It was doubtless with reference to the preparation of the Candidates for Ordination that the Gospel was selected; pointing out, as it does, that there is only one lawful way of entering into the Ministry of Christ; and that those are no true shepherds who do not enter in by the Door, the Chief Shepherd Himself, whose authority on earth is delegated to the Bishops of His Church. The second lesson at Evensong, 1 John iv. 1—13, points in the same direction.

The Whitsun Ember days are of very ancient institution, probably Primitive. They are alluded to by St. Athanasius as the fasts of the week following Pentecost [De fuga sua], and it is plain that no time of the year would be so naturally chosen for continuing the gift of the Spirit by Ordination, as that which follows immediately upon the day when the Holy Ghost first came to inhabit the mystical Body of Christ, for the purpose of "making able" the Ministers of His Gospel-truth and Sacraments.

INTROIT.—Receive ye your joy with glory. Alleluia. Giving thanks unto God. Alleluia. Who hath called you into His heavenly Kingdom. Alleluia. Alleluia. Alleluia. Ps. Hear My law, O My people. Incline your ear to the words of My mouth. Glory be.

TRINITY SUNDAY.

The Octave of Pentecost has been observed in honour of the Blessed Trinity from a very early age of the Church. In the Lectionary of St. Jerome the same Epistle and Gospel are appointed which have always been used in the Church of England; and the Collect is from the Sacramentary of St. Gregory. But the name "Trinity Sunday" was not general until a later period, though it has been used in the English Breviary and Missal since the time of St. Osmund, and may have been adopted by him from still earlier offices of the Church. In the Eastern Church this day is the Festival of all holy Martyrs; a festival which appears to have been observed at this time in the East, even in the days of St. Chrysostom and the Emperor Leo, who have left respectively a Homily and an Oration upon it. It appears to have been regarded as a separate Festival in the western world

only by the Church of England, and those Churches of Germany which owe their origin to the English St. Boniface, or Wilfred¹. Both in the ancient English and in the ancient German Office books, all the Sundays afterwards until Advent are named after Trinity; whereas, in all offices of the Roman type they are named after Pentecost. It seems probable that this distinctive ritual mark is a relic of the independent origin of the Church of England, similar to those peculiarities which were noticed by St. Augustine, and which were attributed by the ancient British bishops to some connexion with St. John. In this case it is, at least, significant that it was St. John through whom the doctrine of the Holy Trinity was most clearly revealed; and also that the early Church of England appears never to have been infested by the heresies on this subject which troubled other portions of the Christian world.

The general observance of the day as a separate Festival in honour of the Blessed Trinity was first enjoined by a Synod of Arles, in A.D. 1260. In Micrologus it is stated [cap. lx.], that the feast was then observed in some parts on the Octave of Pentecost, and in others on the Sunday next before Advent; but that the Roman Church had no such custom, for it honoured the Blessed Trinity in its daily worship by Doxologies and the Memoria, our present Collect². It seems to have become generally observed by the Roman as well as other Churches at the end of the fourteenth century; but the Sundays after it are still named from Pentecost in all the Catholic Churches of the West, except those of England and Germany.

The significance of the festival, as the end of the cycle of days by which our Blessed Lord and His work are commemorated, is very great. The beginning of His acts was associated with a revelation of the Three Persons of the Trinity, and His last command to His Apostles was a commission to make disciples of all nations by baptizing them in the Name of the Father, and of the Son, and of the Holy Ghost. The perfect revelation of the Holy Three in One may also be considered to have been made on the

¹ Gervase of Canterbury asserts that the Feast of Trinity was instituted by St. Thomas of Canterbury soon after his consecration to that see in A.D. 1162, but there can be little doubt it was in some English Office books before that date.

² The Sunday Missa Votiva of Salisbury Use was almost identical with the Mass for Trinity Sunday, but the Epistle was Rom. xi. 33—36, and 2 Cor. xiii. 14; the Gospel being John xv. 26—xvi. 6.

The Trinity Collect was said as a daily memorial (as well as that of Whitsunday), in the Church of England, until 1549. The alteration of the latter part was made by Bishop Cosin in 1661, for what reason is not apparent.

Rev. iv. 8.
Mark xii. 29-34.
2 Pet. iii. 17.
Jude 24, 25.

faith to acknowledge the glory of the eternal Trinity, and in the power of the Divine Majesty to worship the Unity; We beseech thee that thou wouldest keep us stedfast in this faith, and evermore defend us from all adversities, who livest and reignest, one God, world without end. *Amen.*

gloriam agnoscere, et in potentia Majestatis adorare Unitatem, quæsumus, ut ejusdem fidei firmitate ab omnibus semper munimur adversis. Qui vivis et regnas Deus. Per.

EUERLASTYNGE almyȝti god that ȝave us thi seruantis in knowlechyng of verrei feith to knowe the glorie of the endeles trinite, and in the myȝt of mageste to worchipe thee in oonhede: we hisechen that bi the sadness of the same feith we be kept and defendid euermore fro alle aduersities. Bi crist,]

XIVth century Prymer Version.
"sad," from *settan*, to set.

	<i>Modern English.</i>	<i>Salisbury Use.</i>	<i>Modern Roman.</i>	<i>Eastern.</i>
EPISTLE.	Rev. iv. 1-11.	Rev. iv. 1-10.	Rom. xi. 33-36.	Heb. xii. 33. xii. 1.
GOSPEL.	John iii. 1-15.	John iii. 1-15.	Matt. xxviii. 18-20.	Matt. x. 32, 33, 37, 38. xix. 27-30.

THE FIRST SUNDAY AFTER TRINITY.

The Collect.

Ps. ix. 10. xix. 14.
Matt. xxvi. 41.
John xv. 5.
Phil. iv. 13.

O GOD, the strength of all them that put their trust in thee, mercifully accept our prayers; and because

DOMINICA I, POST TRINITATEM.

Oratio.

DEUS in te sperantium fortitudo adesto propitius invocationibus nostris: et quia sine te nihil potest

Salisbury Use. Greg. Hebd. ii. post Pentecosten.

day of Pentecost, when to the work expressed by our Lord in the words, "My Father worketh hitherto, and I work," was added that further operation of the Holy Ghost which was previously unknown even to holy men, but has ever since been familiar to the whole world. On Whitsunday, therefore, we see the crowning point of the work of redemption; and the feast of Trinity, on the Octave of Pentecost, commemorates the consummation of God's saving work, and the perfect revelation to the Church of the Three Persons in One God, as the sole objects of adoration. The love of each Person had been commemorated in the separate Festivals which memorialize before God and man the Incarnation, Death, Resurrection, and Ascension of our Lord, and the sending forth by the Father and the Son of the Blessed Spirit on Whitsunday. In the festival of Trinity all these solemn subjects of belief are gathered into one act of worship, as the Church Militant looks upward through the door that is opened in Heaven, and bows down in adoration with the Church Triumphant, saying, "Holy, Holy, Holy, Lord God Almighty, Which was, and is, and is to come . . . Thou art worthy, O Lord, to receive glory, and honour, and power; for Thou hast created all things, and for Thy pleasure they are and were created."

INTROIT.—Blessed be the holy Trinity, and the indivisible Unity. We will give thanks unto Him, because He hath showed His mercy towards us. Ps. Let us bless the Father, and the Son, with the Holy Ghost.

HYMNS.

EVENSONG AND } *Adesto, Sancta Trinitas.* H. N. 35. 73.
MATTINS. }
COMPLINE. *Salvator mundi, Domine.* H. A. M. 49.
LAUDS. *O Pater Sancte.*

HYMNS FOR TRINITY SEASON.

From the morrow of Trinity Sunday until the Eve of Advent, the ordinary hymns for the week are as follows:—

SUNDAYS. MATTINS. *Primo dierum omnium.* H. N. 3. 5, H. A. M. 21.
LAUDS. *Eterne rerum Conditor.*
COMPLINE. *Salvator mundi, Domine.* H. A. M. 49, C. H. 24.
EVENSONG. *Lucis Creator Optime.* A. N. 8. 11, H. A. M. 24.
MONDAYS. MATTINS. *Somno reffectis artibus.* H. N. 2. 4.
LAUDS. *Splendor Paternæ gloriæ.* H. N. 54. 17, H. A. M. 3.
EVENSONG. *Immense cæli Conditor.* H. N. 55. 18.
COMPLINE. *Te lucis ante terminum.* H. N. 9. 16, H. A. M. 13.
This last hymn is said on all Ferial Days between Trinity and Advent.
TUESDAYS. MATTINS. *Consors Paterni luminis.*
LAUDS. *Alis diei nuntius.* H. N. 56. 19.
EVENSONG. *Telluris ingens Conditor.* H. N. 57. 20.
WEDNESDAYS. MATTINS. *Rerum Creator optime.*
LAUDS. *Nox et tenebræ et nubila.* H. N. 58. 21.
EVENSONG. *Cæli Deus Sanctissime.* H. N. 59. 22.
THURSDAYS. MATTINS. *Nox atra rerum contegit.*
LAUDS. *Lux ecce surgit aurea.* H. N. 60. 23.
EVENSONG. *Magnæ Deus potentia.* H. N. 61. 24.
FRIDAYS. MATTINS. *Tu Trinitatis Unitas.*
LAUDS. *Eterna Cæli gloria.* H. N. 62. 25.
EVENSONG. *Plasmator hominis Deus.*
SATURDAYS. MATTINS. *Summa Deus clementia.*
LAUDS. *Aurora jam spargit polum.* H. N. 64. 27.
EVENSONG. *O Lux beata Trinitas.* H. N. 1. 1.

THE FIRST SUNDAY AFTER TRINITY.

The Sundays and other Festivals from Advent to Trinity form one system of dogmatic illustrations of Christianity: Prayer and

Heb. iv. 16. xiii.
20, 21.

through the weakness of our mortal nature we can do no good thing without thee, grant us the help of thy grace, that in keeping of thy commandments we may please thee, both in will and deed; through Jesus Christ our Lord. *Amen.*

mortalis infirmitas, præsta auxilium gratiæ tuæ; ut in exequendis mandatis tuis, et voluntate tibi et actione placeamus. Per Dominum. Gelas. Dom. vi. post claus. Paschæ.

	<i>Modern English.</i>	<i>Salisbury Use.</i>	<i>Modern Roman.</i>	<i>Eastern.</i>
EPISTLE.	1 John iv. 7—21.	1 John iv. 7—21.	1 John iii. 13—18.	Rom. ii. 10—16.
GOSPEL.	Luke xvi. 19—31.	Luke xvi. 19—31.	Luke xiv. 16—24.	Matt. iv. 18—23.

THE SECOND SUNDAY AFTER TRINITY.

The Collect.

Ps. lxxiii. 1. 23—
26.
John xvii. 11.
Gen. xlviii. 15, 16.
Matt. x. 29, 30.
Deut. x. 12.
Ps. cxi. 9.

O LORD, who never failest to help and govern them whom thou dost bring up in thy stedfast fear and love; Keep us, we beseech thee, under the protection of thy good providence, and make us to have a perpetual fear and love of thy holy Name; through Jesus Christ our Lord. *Amen.*

DOMINICA II., POST TRINITATEM.

Oratio.

SANCTI nominis tui, Domine, timorem pariter et amorem fac nos habere perpetuum; quia nunquam tua gubernatione destituis, quos in soliditate tuæ dilectionis instituis. Per Dominum. Salisbury Use. Greg. Heb. iii. post Pent. Gelas. Dom. post Asc. Dom.

	<i>Modern English.</i>	<i>Salisbury Use.</i>	<i>Modern Roman.</i>	<i>Eastern.</i>
EPISTLE.	1 John iii. 13—24.	1 John iii. 13—18.	1 Pet. v. 6—11.	Rom. v. 1—10.
GOSPEL.	Luke xiv. 16—24.	Luke xiv. 16—24.	Luke xv. 1—10.	Matt. vi. 22—34.

the words of Holy Scripture all combining to present the memorial of primary truths before God in acts of worship, and before man as words of instruction. The Sundays after Trinity may be regarded as a system illustrating the practical life of Christianity, founded on the truths previously represented, and guided by the example of our Blessed Lord. There is a Rubric given on this Sunday in the Salisbury Missal: "Memoria de Trinitate fiat omnibus dominicis usque ad adventum Domini."

The love of God and the love of man are,—one may almost say, of course,—the first subject selected for the Eucharistic Scriptures in this system, as shown in St. John's wonderful definition of love, and in the historical parable of the rich man and Lazarus. In the Epistle St. John shows that God's own love for mankind is the source and spring of all love towards Him, and that all true love towards Him is shown by the evidence of charity. The Gospel, independently of the revelation made in it concerning the state of the departed, places in the most awful light the sin of being without Christian love; and the utter incompatibility of such a condition with a life that will gain the award of future happiness. In teaching this truth our Blessed Lord also revealed to us the intermediate state. Although the Last Judgment was very distant when He told the Jews this history of two men who had, perhaps, been known to them, yet He put it beyond doubt that the souls which had departed from their bodies were as living and conscious as they had ever been, and that their condition was already that of those upon whom a preliminary judgment had been passed; an award of happiness to the one, of torment to the other.

INTROIT.—My trust is in Thy mercy, and my heart is joyful in Thy salvation. I will sing of the Lord, because He hath dealt so lovingly with me. Ps. How long wilt Thou forget me, O Lord, for ever? How long wilt Thou hide Thy face from me? Glory be.

THE SECOND SUNDAY AFTER TRINITY.

The present beautiful version of the ancient Collect for this day was substituted for the literal translation which had previously been used, in 1661. Cosin added "O Heavenly Father" at the end of the old Collect, as if attempting to remedy its abruptness; but the subsequent remoulding of the whole into its present form was a happy improvement, giving us one of the finest of our English Collects. It will be observed that its tone is in close agreement with that of the INTROIT.

The subject of Active Love is again taken up on this Sunday, the Epistle coming from a preceding chapter of St. John to that used on the previous Sunday, and the Gospel from an earlier chapter of St. Luke.

INTROIT.—The Lord was my upholder. He brought me forth also into a place of liberty; He brought me forth even because He had a favour unto me. Ps. I will love Thee, O Lord my Strength; the Lord is my strong rock and my defence, and my Saviour. Glory be.

THE THIRD SUNDAY AFTER TRINITY.

The Collect.

Ps. xxx. 10.
Rom. viii. 26.
Ps. lxxii. 5, 6.
2 Cor. i. 3, 4.
1 Pet. v. 10, 11.

O LORD, we beseech thee mercifully to hear us; and grant that we, to whom thou hast given an hearty desire to pray, may by thy mighty aid be defended and comforted in all dangers and adversities; through Jesus Christ our Lord. *Amen.*

DOMINICA III., POST TRINITATEM.

Oratio.

DEPRECA^{Salisbury Use.}TIONEM nostram ^{Greg. Hebd. iv.} quæsumus, Domine, benignus ^{post Pent.} exaudi; et quibus supplicandi præstas affectum, tribue defensionis auxilium. Per.

	<i>Modern English.*</i>	<i>Salisbury Use.</i>	<i>Modern Roman.</i>	<i>Eastern.</i>
EPISTLE.	1 Pet. v. 5—11.	1 Pet. v. 5—11.	Rom. viii. 18—23.	Rom. vi. 18—23.
GOSPEL.	Luke xv. 1—10.	Luke xv. 1—10.	Luke v. 1—11.	Matt. viii. 5—13.

THE FOURTH SUNDAY AFTER TRINITY.

The Collect.

Ps. xxxvii. 39, 40.
Isa. xl. 29, 31.
John xv. 4, 5.
Jude 2.
Ps. xlviii. 14.
Heb. xi. 8—10.
24—26.
Ps. lxxiii. 24.

O GOD, the protector of all that trust in thee, without whom nothing is strong, nothing is holy; Increase and multiply upon us thy mercy; that, thou being our ruler and guide, we may so pass through things temporal, that we finally lose not the things eternal: Grant this, O heavenly Father, for Jesus Christ's sake our Lord. *Amen.*

DOMINICA IV., POST TRINITATEM.

Oratio.

PROTECTOR in te sperantem ^{Salisbury Use.} Deus, sine quo nihil est validum, ^{Greg. Hebd. v.} nihil sanctum; multiplica super nos misericordiam tuam, ut te Rectore, te Duce, sic transeamus per bona temporalia, ut non amittamus æterna. Per Dominum.

	<i>Modern English.</i>	<i>Salisbury Use.</i>	<i>Modern Roman.</i>	<i>Eastern.</i>
EPISTLE.	Rom. viii. 18—23.	Rom. viii. 18—23.	1 Pet. iii. 8—15.	Rom. x. 1—10.
GOSPEL.	Luke vi. 36—42.	Luke vi. 36—42.	Matt. v. 20—24.	Matt. viii. 28—34.

THE THIRD SUNDAY AFTER TRINITY.

The Christian virtue of Humility is set forth in the Epistle for this Sunday, in the words of St. Peter; and illustrated in the Gospel by the example of our Blessed Lord in receiving sinners and eating with them. The Collect, however, seems to take its tone from the latter portion of the Epistle, which speaks of the afflictions and sufferings to which the early Christians were subjected. The Epistle and the Collect are, in fact, much more frequently associated together in tone and language, than the Collect and the Gospel; indicating a probability that the Gospels were not read in the Communion Service until a later period than that in which the Epistles came to be used.

INTROIT.—Turn Thee unto me, and have mercy upon me: for I am desolate and in misery. Look upon my adversity and misery; and forgive me all my sin, O my God. Ps. Unto Thee, O Lord, will I lift up my soul; my God, I have put my trust in Thee; O let me not be confounded. Glory be.

THE FOURTH SUNDAY AFTER TRINITY.

In the Gospel for this day, Mercy, another of the Christian virtues, is set forth in the words of our Lord, beginning, "Be ye therefore merciful, as your Father also is merciful," enforced by the proverbs of the blind leading the blind, the disciple not being

above his Master, and of the mote and the beam. The Collect also refers to the mercy of our heavenly Father, and seems to have been suggested by the Gospel. But, as on the preceding Sunday, the Epistle seems to have been selected with reference to a time when the Church was passing through some great tribulation, and when Christians needed frequently to be reminded that they had here no continuing city, but must look beyond the sufferings of this present time to the glory hereafter to be revealed.

It is possible that the Gospel may have been selected under the influence of similar circumstances, an age of martyrdoms suggesting to those who had so clear a vision of Christ's example the duty of mercy and love towards their persecutors. For themselves they could only look to that future bliss which was to outweigh the present suffering: for the Church of succeeding days they could leave such a legacy as St. Stephen did, when he prayed with his dying lips, "Lord, lay not this sin to their charge." The INTROIT for the day seems equally to reflect an age of persecution.

INTROIT.—The Lord is my light and my salvation; whom then shall I fear: the Lord is the strength of my life; of whom then shall I be afraid? When the wicked, even mine enemies, and my foes, came upon me to eat up my flesh, they stumbled and fell. Ps. Though an host of men were laid against me, yet shall not my heart be afraid. Glory be.

THE FIFTH SUNDAY AFTER TRINITY.

The Collect.

Ps. lxxii. 7.
cxlii. 6.
Luke i. 18. 74. 75.
Isa. xxxii. 17, 18.

GRANT, O Lord, we beseech thee, that the course of this world may be so peaceably ordered by thy governance, that thy Church may joyfully serve thee in all godly quietness; through Jesus Christ our Lord. *Amen.*

DOMINICA V., POST TRINITATEM.

Oratio.

DA nobis quæsumus, Domine, ut et mundi cursus pacifice nobis tuo ordine dirigatur et Ecclesia tua tranquilla devotione lætetur. Per Dominum.

Salisbury Use.
Greg. Hebd. vi.
post Pent.
Leo, in Murat.
i. 379.

	<i>Modern English.</i>	<i>Salisbury Use.</i>	<i>Modern Roman.</i>	<i>Eastern.</i>
EPISTLE.	1 Pet. iii. 8—15.	1 Pet. iii. 8—15.	Rom. vi. 3—11.	Rom. xii. 6—14.
GOSPEL.	Luke v. 1—11.	Luke v. 1—11.	Mark viii. 1—9.	Matt. ix. 1—8.

THE SIXTH SUNDAY AFTER TRINITY.

The Collect.

Ps. xxxi. 19.
1 Cor. ii. 9.
2 Thess. iii. 3.
Matt. xxii. 37.
2 Pet. i. 3.
James i. 12.

O GOD, who hast prepared for them that love thee such good things as pass man's understanding; Pour into our hearts such love toward thee, that, we, loving thee above all things, may obtain thy promises, which exceed all that we can desire; through Jesus Christ our Lord. *Amen.*

DOMINICA VI., POST TRINITATEM.

Oratio.

DEUS qui diligentibus te bona invisibilia præparasti; infunde cordibus nostris tui amoris affectum; ut te in omnibus et super omnia diligentes, promissiones tuas, quæ omne desiderium superant, consequamur. Per Dominum.

Salisbury Use.
Greg. Hebd. vii.
post Pent.
Gelas. iii. 1.

	<i>Modern English.</i>	<i>Salisbury Use.</i>	<i>Modern Roman.</i>	<i>Eastern.</i>
EPISTLE.	Rom. vi. 3—11.	Rom. vi. 3—11.	Rom. vi. 19—23.	Rom. xv. 1—7.
GOSPEL.	Matt. v. 20—26.	Matt. v. 20—24.	Matt. vii. 15—21.	Matt. ix. 27—35.

THE FIFTH SUNDAY AFTER TRINITY.

The ancient Leonine Collect for this day seems to have been suggested, says Mr. Bright, like several of the same age, by the disasters of the dying Western Empire¹. It has, however, a plain connexion with the Gospel, which was probably selected at an earlier date. Like others of our Lord's Miracles, this one was a parable as well, in which He was teaching the Apostles principles respecting their future work. The sea is the world, the net is the Church, the Apostles are fishers of men, Christ is He Who in the spiritual as in the actual world bids them let down the net, and also gathers into it the great multitude of fishes. Very significant is it, then, that with this parabolic miracle in the Gospel, the Collect should pray Him Whose Presence was the wealth and the safety of the fishermen, that He will so order the waves of this troublesome world that the Ark of the Church may ever ride over them in peace, and serve Him by gathering in souls into her nets with all godly quietness through the blessing of the Saviour's Presence. The Epistle is in close agreement with this tone,—“The eyes of the Lord are over the righteous, and His ears are open unto their prayers. . . . Who is he that will harm you if ye be followers of that which is good?” Like those of the preceding Sundays, it reflects a time of persecution, such as was passing over the Church when St. Peter wrote; but it also breathes the strong faith of him who had said, “Lord, if it be Thou, bid me come unto Thee on the water,” and whose experience had taught him that if Jesus be in the ship, no waves or storms can prevail to overwhelm it.

¹ Ancient Collects, p. 208.

INTROIT.—Hearken unto my voice, O Lord, when I cry unto Thee: have mercy upon me, and hear me. Thou hast been my succour: leave me not, neither forsake me, O God of my salvation. Ps. The Lord is my Light and my Salvation, whom then shall I fear?

THE SIXTH SUNDAY AFTER TRINITY.

This day sets forth the principle that the obligation of the old law is heightened under the New Dispensation: as also that the stricter obligation of the new law is accompanied by a proportionate increase in the grace by which the duty of obedience to God may be fulfilled. Christ's law extends to the wilful conception of an act as well as to the act itself, and accounts the one a sin as well as the other. But Christ's death and resurrection extend themselves to the sacrament of Baptism, making it the means of a death unto sin and a new birth unto righteousness: and thus endowing Christians with a power to fulfil the requirements of His law which otherwise they could not possess. The power of Christ against sin becomes thus not only a power external to the soul, but an inward capacity, the practical use or disuse of which is at the will of those to whom it is given.

INTROIT.—The Lord is my strength, and He is the wholesome defence of His Anointed. O save Thy people, and give Thy blessing unto Thine inheritance; feed them, and set them up for ever. Ps. Unto Thee will I cry, O Lord, my strength; think no scorn of me, lest if Thou make as though Thou hearest not, I become like them that go down into the pit. Glory be.

THE SEVENTH SUNDAY AFTER TRINITY.

The Collect.

2 Chron. xx. 6.
Matt. vii. 11.
John xiii. 26.
Jer. xxxi. 14.
Eph. v. 29.
2 Thess. iii. 3.

LORD of all power and might, who art the author and giver of all good things; Graft in our hearts the love of thy Name, increase in us true religion, nourish us with all goodness, and of thy great mercy keep us in the same; through Jesus Christ our Lord. *Amen.*

DOMINICA VII., POST TRINITATEM.

Oratio.

DEUS virtutum, cujus est totum quod est optimum; insere peccatoribus nostris amorem tui nominis, et præsta in nobis religionis augmentum, ut quæ sunt bona nutrias, ac pietatis studio quæ sunt nutrita custodias. Per Dominum.

Salisbury Use.
Greg. Hebd. viii.
post Pent.
Gelas. iii. 2.

	<i>Modern English.</i>	<i>Salisbury Use.</i>	<i>Modern Roman.</i>	<i>Eastern.</i>
EPISTLE.	Rom. vi. 19—23.	Rom. vi. 19—23.	Rom. viii. 12—17.	1 Cor. i. 10—17.
GOSPEL.	Mark viii. 1—9.	Mark viii. 1—9.	Luke xvi. 1—9.	Matt. xiv. 14—22.

THE EIGHTH SUNDAY AFTER TRINITY.

The Collect.

Dan. iv. 35.
Prov. xvi. 33.
Matt. vi. 13.
Ps. lxxxiv. 11.
Phil. iv. 19.

O GOD, whose never-failing providence ordereth all things both in heaven and earth; We humbly beseech thee to put away from us all hurtful things, and to give us those things which be profitable for us; through Jesus Christ our Lord. *Amen.*

DOMINICA VIII., POST TRINITATEM.

Oratio.

DEUS, cujus providentia in sui dispositione non fallitur, te supplices exoramus, ut noxia cuncta submoveas, et omnia nobis profutura concedas. Per Dominum.

Salisbury Use.
Greg. Hebd. ix.
post Pent.
Gelas. iii. 3.

	<i>Modern English.</i>	<i>Salisbury Use.</i>	<i>Modern Roman.</i>	<i>Eastern.</i>
EPISTLE.	Rom. viii. 12—17.	Rom. viii. 12—17.	1 Cor. x. 6—13.	1 Cor. iii. 9—17.
GOSPEL.	Matt. vii. 15—21.	Matt. vii. 15—21.	Luke xix. 41—47.	Matt. xiv. 22—34.

THE NINTH SUNDAY AFTER TRINITY.

The Collect.

* Ps. xix. 14.
Phil. iv. 8.
John xv. 3.
Phil. ii. 11.
Col. iv. 12.
Heb. xiii. 20, 21.

GRANT to us, Lord, we beseech thee, the spirit to think and do always such things as be rightful;

DOMINICA IX., POST TRINITATEM.

Oratio.

LARGIRE nobis, quæsumus, Domine, semper spiritum cogitandi quæ recta sunt, propitius, et agendi;

Salisbury Use.
Greg. Hebd. x.
post Pent.
Leo, in Murat. i. 434.

THE SEVENTH SUNDAY AFTER TRINITY.

The Collect for this day has expressions in it which seem to connect its prayer with both the Epistle and the Gospel. The petition, "Graft in our hearts the love of Thy Name," appears to be suggested by the idea of good and evil fruit contained in the former; while "Giver of all good things" and "nourish us with all goodness" plainly point out a devotional application of the narrative which the Gospel gives of the good Shepherd feeding His flock of four thousand with seven loaves and a few small fishes. The bondage of sin and the service of Christ are contrasted in the Epistle, which seems to be the source of the beautiful expression, "Whose service is perfect freedom," in the second Collect at Mattins. The same idea may be also found in the Gospel, where Christ's *command* that the people should sit down (though it seemed a mere arbitrary command) was followed by the reward of obedience, His bounty.

INTROIT.—O clap your hands together, all ye people; O sing unto God with the voice of melody. Ps. He shall subdue the people under us, and the nations under our feet. Glory be.

THE EIGHTH SUNDAY AFTER TRINITY.

The Service of Christ is set forth in the Epistle of to-day as

no slavery, but a sonship. Those who do the works of a true obedience to Him do them by the help of the Spirit of God; those who are led by the Spirit of God are adopted children of Him whose Only-begotten received the same Spirit without measure; those who are adopted sons of God are heirs of His eternal gifts, joint-heirs with Christ Himself, reigning with Him as priests and kings for ever. Such is the course of the Apostle's reasoning and revelation; and it is further illustrated by the words of our Lord in the Gospel, which, as the saying of the Eternal Word, living and powerful and sharper than any two-edged sword, discriminates between those who only say unto Him, "Lord, Lord," by an outward profession, and those whose sonship is made evident by their fruits, the doing of the will of God.

INTROIT.—We wait for Thy loving-kindness, O God, in the midst of Thy temple. O God, according to Thy Name, so is Thy praise unto the world's end; Thy right hand is full of righteousness. Ps. Great is the Lord, and highly to be praised; in the city of our God, even upon His holy hill. Glory be.

THE NINTH SUNDAY AFTER TRINITY.

The key-note of the office for this day is struck by our Lord's words in the end of the Gospel, "Make to yourselves friends of

that we, who cannot do any thing that is good without thee, may by thee be enabled to live according to thy will; through Jesus Christ our Lord. *Amen.*

ut qui sine te esse non possumus, secundum te vivere valeamus. Per Dominum.

	<i>Modern English.</i>	<i>Salisbury Use.</i>	<i>Modern Roman.</i>	<i>Eastern.</i>
EPISTLE.	1 Cor. x. 1—13.	1 Cor. x. 1—13.	1 Cor. xii. 2—11. *	1 Cor. iv. 9—16.
GOSPEL.	Luke xvi. 1—9.	Luke xvi. 1—9.	Luke xviii. 9—14.	Matt. xvii. 14—23.

THE TENTH SUNDAY AFTER TRINITY.

The Collect.

Neh. i. 11.
1 Pet. iii. 12.
1 Chron. i. 11, 12.
2 Chron. iv. 10.
1 John v. 14.

LET thy merciful ears, O Lord, be open to the prayers of thy humble servants; and that they may obtain their petitions make them to ask such things as shall please thee; through Jesus Christ our Lord. *Amen.*

DOMINICA X., POST TRINITATEM.

Oratio.

PATEANT aures misericordiæ tuæ, Domine, precibus supplicantium; et ut petentibus desiderata concedas, fac eos quæ tibi placita sunt postulare. Per Dominum nostrum.

Salisbury Use
Gelas. iii. 5.
Leo, in Murat
i. 331.

	<i>Modern English.</i>	<i>Salisbury Use.</i>	<i>Modern Roman.</i>	<i>Eastern.</i>
EPISTLE.	1 Cor. xii. 1—11.	1 Cor. xii. 1—11.	1 Cor. xv. 1—10.	1 Cor. ix. 2—12.
GOSPEL.	Luke xix. 41—47.	Luke xix. 41—47*	Mark vii. 31—37.	Matt. xviii. 23—25.

the Mammon of unrighteousness, that when ye fail, they may receive you into everlasting habitations." For by the unjust steward in the parable, of which these words give the application, is represented the Christian in his way through this life; and the children of Israel are represented to us in the Epistle on their way through the wilderness. By the temptations to which the latter were subjected are set forth as in a living parable the lot of the "children of light," who also must pass through such temptations as are "common to man." The worldly wisdom of the steward our Lord uses as an example of the manner in which the children of light are to use the temptations of life as a means by which they may make friends in heaven among the angels and saints. Out of the Mammon of unrighteousness,—the idols of this life which men are tempted to fall down and worship,—this profit may arise to him who is tempted, that his trial by their means is like our Lord's temptation by Satan, a trial which will result in greater perfection and fitness for the further work set before him to do, if due use is made of that way of escape by which he may be able to bear it. Such temptations were offered to the first Israel, and the people gave way before them; they are also offered to God's new Israel, and the words of our Lord are an exhortation to them, that as "children of light" they should be as wise for spiritual objects as "the children of this world" (recklessly irreligious, yet provident and politic, men) are for the objects which they set themselves to attain as the desire of their life.

INTROIT.—Behold, God is my helper: the Lord is with them that uphold my soul. He shall reward evil unto mine enemies: destroy Thou them in Thy truth. Ps. Save me, O God, for Thy Name's sake; and avenge me in Thy strength. Glory be.

THE TENTH SUNDAY AFTER TRINITY.

There is a touching connexion between the Epistle and Gospel of this day which seems as if it could hardly be accidental; or, if it is, offers an illustration of the manner in which all Holy Scrip-

ture gives evidence that it is drawn from one Fountain of truth. The Gospel shows our Blessed Lord weeping over Jerusalem, because she had failed to recognize the things that belonged to her peace. The Prince of Peace had come to her, offering the good gifts which are ever the fruits of His Presence, but her eyes had been blinded by her wilfulness, those gifts of peace had been rejected, and now they were hid from her. Our Lord's last words of warning a few days afterwards were in the same strain, "Walk while ye have the light, lest darkness come upon you While ye have light, believe in the light, that ye may be the children of light." They were the last public words of the Light of the world before His Passion began; and when He had spoken them, He "departed, and did hide Himself from them" [John xii. 36]. With such an experience before the new Israel of God, the Apostle St. Paul exhorts them not to be ignorant of the spiritual gifts with which they have been blessed: those manifold operations of the Holy Ghost on the souls of men, by which they are fitted for the work of the ministry, or for that of ordinary Christian life. And the association of these two portions of Holy Scripture comes as a perennial warning to Churches in their corporate capacity, and to individual Christians, calling them to remember that as Jesus had cause to weep over the neglect of His gifts when offered to the Jews, so is such a neglect cause of sorrow even now in Heaven, and may be followed by the judgment which fell upon her of old who knew not the time of her visitation. The enemies of the Church are ever ready to dig their trenches and compass her around, and lay her even with the ground. Her true strength is, that she should ever remember and use her spiritual gifts, and know the value of Christ's Presence in the time when He visits her with His salvation.

INTROIT.—When I cried unto the Lord, He heard my voice in the battle that was against me: yea, even God that endureth for ever shall hear me and cast them down. O cast thy burden upon the Lord, and He shall nourish thee. Ps. Hear my prayer, O Lord, and hide not Thyself from my petition. Take heed unto me, and hear me. Glory be.

THE ELEVENTH SUNDAY AFTER TRINITY.

The Collect.

Wisd. xii. 16.
Isa. lxiii. 7, 9.
John xvii. 1, 2.
Eph. iv. 7.
1 Cor. ix. 24.
1 John ii. 25.
Matt. vi. 20.

O GOD, who declarest thy almighty power most chiefly in shewing mercy and pity; Mercifully grant unto us such a measure of thy grace, that we, running the way of thy commandments, may obtain thy gracious promises, and be made partakers of thy heavenly treasure; through Jesus Christ our Lord. *Amen.*

DOMINICA XI., POST TRINITATEM.

Oratio.

DEUS, qui omnipotentiam tuam parcendo maxime et miserando manifestas; multiplica super nos gratiam tuam, ut ad tua promissa currentes, celestium bonorum facias esse consortes. *Per.*

Salisbury Use.
Greg. Hebd. xii.
post Pent.
Gelas. iii. 6.

	<i>Modern English.</i>	<i>Salisbury Use.</i>	<i>Modern Roman.</i>	<i>Eastern.</i>
EPISTLE.	1 Cor. xv. 1—11.	1 Cor. xv. 1—11.	2 Cor. iii. 4—9.	1 Cor. xv. 1—11.
GOSPEL.	Luke xviii. 9—14.	Luke xviii. 9—14.	Luke x. 23—37.	Matt. xix. 16—26.

THE TWELFTH SUNDAY AFTER TRINITY.

The Collect.

Isa. lxxv. 24.
Ps. x. 17.
1 Kings iii. 11, 12.
Luke xv. 20—22.
Exod. xxiv. 6, 7.
Ps. cxxx. 3, 4.
lxxxiv. 11.
John xvi. 23.

ALmighty and everlasting God, who art always more ready to hear than we to pray, and art wont to give more than either we desire, or deserve; Pour down upon us the

DOMINICA XII., POST TRINITATEM.

Oratio.

OMNIPOTENS sempiternæ Deus, qui abundantia pietatis tuæ et merita supplicum excedis et vota; effunde super nos misericordiam tuam; ut dimittas quæ conscientia metuit, et

Salisbury Use.
Greg. Hebd. xiii.
post Pent.
Gelas. iii. 7.
Leo, in Murat.
i. 418.

THE ELEVENTH SUNDAY AFTER TRINITY.

The subject of this Sunday is the mercy and pity of Almighty God in bestowing the power of supernatural grace as a free and undeserved gift upon sinners. St. Paul's "I am the least of the Apostles, that am not meet to be called an Apostle, because I persecuted the Church of God," is a parallel to the Publican's "God be merciful to me a sinner;" and our Lord's declaration, that the Publican went down to his house justified because of his humility, is a parallel to the inspired words of the Apostle, "By the grace of God I am what I am . . . yet not I, but the grace of God which was with me." "Ancient writers, as St. Augustine and others," says Isaac Williams, "delight to dwell on these words of St. Paul, as so expressive of his sweet, trembling humility, fearing to contemplate himself, except in his sins and infirmities, and losing all sense of his greatness in God; fearful lest he should presume, and so lose by presumption all that crown of hope and joy which by humility he had gained." This tone of the holy Apostle, and that of the Publican, is strikingly taken up by the Collect, which offers also a fine specimen of the fulness of devotion which may be gathered into this form of prayer. Short as it is, this Collect contains five several subjects, each of which is like the condensation of a volume of devotion. Those subjects are (1) the mercy of God; and let it be noted, how suggestive is the idea, that this mercy is the chief manifestation of Almighty Power; (2) the grace of God, as His gift, according to the measure of our necessities; (3) obedience, as accomplished only by the power of grace; (4) the fulfilment of the Divine promises; (5) the "great recompence of reward," the "heavenly treasures," of which Isaiah and St. Paul wrote, "Eye hath not seen, nor ear heard, neither have entered into the heart of man the things which God hath prepared for them that love Him." Such fulness of meaning approaches very nearly to that of inspiration, and may well lead us to the belief, that a special blessing from God rested upon the intellect and devotional instinct of the original writer.

INTROIT.—It is God that maketh men to be of one mind in an house. He will give strength and power unto His people. Ps. Let God arise, and let His enemies be scattered: let them also that hate Him flee before Him. Glory be.

THE TWELFTH SUNDAY AFTER TRINITY.

The contrast between the Old and New Dispensations is vividly set forth in the Gospel and Epistle for this Sunday. Glorious as the former was in its origin and in its continuation, it was a ministration of condemnation, with sacrifices of atonement, but with no sacraments of life. The Incarnation of the Son of God was the origin, and the Mystical Presence of Christ the continuation of a spiritual life which the world had not before known since the Fall. The Church of God had grown deaf, and heard not the Voice from Heaven as that Voice had been heard of old; there was an impediment in her speech, so that the word of God did not go forth from her lips in prophecy. The Son of God came down on earth, and touched her by making Himself one with her through His human nature; the sigh of His Passion was followed by the "Ephphatha" of the Resurrection; and as soon as His work was perfected, by the looking up to Heaven of His Ascension and Session at the right hand of God, the ears of the deaf were unstopped to receive the Inspiration of Pentecost, and the tongue of the dumb loosed, so that "their sound is gone out into all lands, and their words into the ends of the world." The same Touch of Christ and communication of grace in the communication of that which forms part of His Person, is still the means by which the Church as a corporate body, and every individual member of it as a living member, is vivified and sustained; and He who gives spiritual ability to the ministers of the New Testament, that their acts and words may be the means by which His Presence is continued in the Church, is making the ministration of righteousness, even in the by-places of the earth, to exceed in glory the ministration of Moses at the foot of Sinai.

abundance of thy mercy; forgiving us those things whereof our conscience is afraid, and giving us those good things which we are not worthy to ask, but through the merits and mediation of Jesus Christ, thy Son, our Lord. *Amen.*

adjicias quæ oratio non præsumit.
Per Dominum.

	<i>Modern English.</i>	<i>Salisbury Use.</i>	<i>Modern Roman.</i>	<i>Eastern.</i>
EPISTLE.	2 Cor. iii. 4—9.	2 Cor. iii. 4—9.	Gal. iii. 16—22.	1 Cor. xvi. 13—24.
GOSPEL.	Mark vii. 31—37.	Mark vii. 31—37.	Luke xvii. 11—19.	Matt. xxi. 33—42.

THE THIRTEENTH SUNDAY AFTER TRINITY.

The Collect.

Prov. xvi. 1.
1 Cor. iv. 7.
Col. iii. 23, 24.
John xii. 25, 26.
Heb. vi. 11, 12.
xii. 23.
Rev. ii. 10. iii. 21.

ALmighty and merciful God, of whose only gift it cometh that thy faithful people do unto thee true and laudable service; Grant, we beseech thee, that we may so faithfully serve thee in this life, that we fail not finally to attain thy heavenly promises; through the merits of Jesus Christ our Lord. *Amen.*

DOMINICA XIII., POST TRINITATEM.

Oratio.

OMNIPOTENS et misericors Deus, de cujus munere venit, ut tibi a fidelibus tuis digne et laudabiliter serviatur, tribue nobis, quæsumus, ut ad promissiones tuas sine offensione curramus. Per Dominum nostrum.

Salisbury Use.
Greg. super
populum.
Hebd. xiv.
post Pent.
Leo, in Murat.
i. 371.

	<i>Modern English.</i>	<i>Salisbury Use.</i>	<i>Modern Roman.</i>	<i>Eastern.</i>
EPISTLE.	Gal. iii. 16—22.	Gal. iii. 16—22.	Gal. v. 16—24.	2 Cor. i. 21—ii. 4.
GOSPEL.	Luke x. 23—37.	Luke x. 23—37.	Matt. vi. 24—33.	Matt. xxii. 2—14.

THE FOURTEENTH SUNDAY AFTER TRINITY.

The Collect.

1 Cor. xiii. 13.
Luke xvii. 5.
Rom. xv. 13.
2 Pet. i. 5—7.

ALmighty and everlasting God, give unto us the increase of faith, hope, and charity; and, that we

DOMINICA XIV., POST TRINITATEM.

Oratio.

OMNIPOTENS sempiternæ Deus, da nobis fidei, spei, et charitatis augmentum; et ut mereamur assequi

Salisbury Use.
Greg. Hebd. xv.
post Pent.
Leo, in Murat.
i. 374.

INTROIT.—Haste Thee, O God, to deliver me: make haste to help me, O Lord. Let them be ashamed that seek after my soul. Ps. Let them be turned backward and put to confusion, that wish me evil. Glory be.

THE THIRTEENTH SUNDAY AFTER TRINITY.

The glory of the New Dispensation is again set forth in the Scriptures for this day, but the parable of the good Samaritan comes in with singular fitness, since the Thirteenth Sunday after Trinity almost always occurs during the harvest (at some time between August 17th and September 19th), when the Christian charities of social life are a subject that should mingle with our thanksgivings for God's goodness in giving us the fruits of the season. The parable sets forth, in its mystical phase, the exceeding goodness and charity of the Lord Himself, Who became the good Samaritan to human nature at large when it had fallen into the hands of spiritual foes, had been stripped of the clothing of original righteousness, and left half dead in trespasses and sins. But out of the love which Christ bore springs our love both to Him and to our neighbour. We love Him because He first loved us; and our love for others is the necessary fruit of our love for Him. It is the application of this principle which forms the literal teaching

of the parable; the extreme case given being given for that very reason to show how extensive is the bond of neighbourliness; and how extensive, in consequence, the character of the duties which spring out of it. If a Jew and a Samaritan are set forth for our example as neighbours in the Christian sense, what Christians are not neighbours to each other?

The temporal gifts of God's good Providence suggest, then, an awakening of the spirit of kindness, that those who are among the less "fortunate," may be looked upon by those who are more so as sent to test their practical Christianity: and those who read the parable rightly, can hardly fail to find some occasion for an active obedience to our Lord's precept, "Go and do thou likewise."

INTROIT.—Look upon Thy covenant. Forsake not for ever the souls of the poor. Arise, O Lord, and maintain Thine own cause, and forget not the voice of them that seek Thee. Ps. O God, wherefore art Thou absent from us so long: why is Thy wrath so hot against the sheep of Thy pasture? Glory be.

THE FOURTEENTH SUNDAY AFTER TRINITY.

The Gospel for this Sunday, like the last, is a memorial of harvest, setting forth the duty of Christian thanksgiving by the

John xiv. 15, 16. may obtain that which thou dost pro- quod promittis, fac nos amare quod
19, 21, 23. mise, make us to love that which thou præcipis. Per Dominum.
Rev. xxii. 14. dost command; through Jesus Christ
our Lord. *Amen.*

	<i>Modern English.</i>	<i>Salisbury Use.</i>	<i>Modern Roman.</i>	<i>Eastern.</i>
EPISTLE.	Gal. v. 16—24.	Gal. v. 16—24.	Gal. v. 25—vi. 10.	2 Cor. iv. 6—15.
GOSPEL.	Luke xvii. 11—19.	Luke xvii. 11—19.	Luke vii. 11—16.	Matt. xxii. 35—46.

THE FIFTEENTH SUNDAY AFTER TRINITY.

The Collect.

Matt. xvi. 18.
Isa. liv. 10.
1 Cor. x. 12.
Matt. vi. 13.
Isa. xlviii. 17.
2 Thess. iii. 3.
KEEP, we beseech thee, O Lord, thy Church with thy perpetual mercy: and, because the frailty of man without thee cannot but fall, keep us ever by thy help from all things hurtful, and lead us to all things profitable to our salvation; through Jesus Christ our Lord. *Amen.*

DOMINICA XV., POST TRINITATEM.

Oratio.

CUSTODI, quæsumus, Domine, ecclesiam tuam propitiatione perpetua; et quia sine te labitur humana mortalitas, tuis semper auxiliis et abstrahatur a noxiis, et ad salutaria dirigatur. Per.

Salisbury Use.
Greg. Hebd. xvi.
post Pent.
Gelas. iii. 10.

	<i>Modern English.</i>	<i>Salisbury Use.</i>	<i>Modern Roman.</i>	<i>Eastern.</i>
EPISTLE.	Gal. vi. 11—18.	Gal. v. 25—vi. 10.	Eph. iii. 13—21.	2 Cor. vi. 1—10.
GOSPEL.	Matt. vi. 24—34.	Matt. vi. 24—33.	Luke xiv. 1—11.	Matt. xxv. 14—30.

THE SIXTEENTH SUNDAY AFTER TRINITY.

The Collect.

Ps. ciii. 13.
Eph. v. 25—27.
Ps. cxxvii. 1.
li. 8.
1 Thess. v. 23.
O LORD, we beseech thee, let thy continual pity cleanse and defend thy Church; and because it can-

DOMINICA XVI., POST TRINITATEM.

Oratio.

ECCLESIAM tuam, quæsumus, Domine, miseratio continuata mundet et muniat; et quia sine te non

Salisbury Use.
Greg. Hebd. xvii.
post Pent.
Gelas. iii. 11.

example of the one leper out of the ten cleansed who returned to give glory to God in Christ. Leprosy being incurable, except by a miracle, the act of our Lord is typical of that continual wonder-working by which He sustains our life, and gives to us the bounties of His Providence; and the act of thanksgiving suggests the recognition, at this time of the year, of the hand of God prospering by its mysterious operation the work of man in producing the great necessary of life. Such a recognition involves falling down at the feet of God in thankful adoration: the absence of it leads men to depart on their way unheedful of the supernatural character which is involved in even the most ordinary provision for the necessities of life.

INTROIT.—Behold, O God, our Defender, and look upon the face of Thine Anointed. For one day in Thy courts is better than a thousand. Ps. O how amiable are Thy dwellings, Thou Lord of Hosts! Glory be.

THE FIFTEENTH SUNDAY AFTER TRINITY.

The Gospel for this Sunday is also a harvest Gospel, pointing out that true Christian forethought is that which is intimately associated with dependence on the Providence of God. When the stores of the principal provision for the year are gathered in, then comes the lesson taught by Christ's own words, that sowing, and reaping, and gathering into barns, is not the chief work of a Christian's life; and that God's bounty, which feeds the birds of

the air, and clothes the lilies of the field by *other* means than their own toil, is the same bounty which is feeding and clothing us by *means* of our toil. Forethought in respect to such things, should therefore be a forethought which is consistent with trust in God, and with seeking first the things of His Kingdom.

INTROIT.—Bow down Thine ear, O Lord, and hear me. My God, save Thy servant that putteth his trust in Thee. Be merciful unto me, for I will call daily upon Thee. Ps. Comfort the soul of Thy servant: for unto Thee do I lift up my soul. Glory be.

THE SIXTEENTH SUNDAY AFTER TRINITY.

The compassion of Christ is illustrated by the Gospel of this Sunday, which is that narrating the restoration to life of the widow's son; the pity of the Father is besought for the Church; and the earnest prayer of St. Paul in the Epistle exemplifies the spirit in which such a prayer should be offered, as well as the nature of the blessings to be prayed for.

Our Lord's meeting with the funeral procession at the gate of the city may be taken as a beautiful precedent for the custom ordered in the second rubric of the Burial Service: and when mourners hear Christ's ministers, on such an occasion, saying, "I am the Resurrection and the Life," they may remember with thankful hope that these are the words of Him Who, saying "Weep not . . . came and touched the bier," and said also, "Young man, I say unto thee, Arise."

not continue in safety without thy succour, preserve it evermore by thy help and goodness; through Jesus Christ our Lord. *Amen.*

potest salva consistere, tuo semper munere gubernetur. Per Dominum.

	<i>Modern English.</i>	<i>Salisbury Use.</i>	<i>Modern Roman.</i>	<i>Eastern.</i>
EPISTLE.	Eph. iii. 13—21.	Eph. iii. 13—21.	Eph. iv. 1—6.	2 Cor. vi. 16, vii. 1.
GOSPEL.	Luke vii. 11—17.	Luke vii. 11—16.	Matt. xxii. 35—46.	Matt. xv. 21—28.

THE SEVENTEENTH SUNDAY AFTER TRINITY.

The Collect.

Prov. xvi. 3.
Phil. ii. 8.
Tit. iii. 8.
Matt. v. 16.

LORD, we pray thee that thy grace may always prevent and follow us, and make us continually to be given to all good works; through Jesus Christ our Lord. *Amen.*

DOMINICA XVII., POST TRINITATEM.

Oratio.

TUA nos, Domine, quæsumus, gratia semper et præveniat et sequatur; ac bonis operibus jugiter præstet esse intentos. Per Dominum.

Salisbury Use.
Greg. Orationes
Quotidianæ.

	<i>Modern English.</i>	<i>Salisbury Use.</i>	<i>Modern Roman.</i>	<i>Eastern.</i>
EPISTLE.	Eph. iv. 1—6.	Eph. iv. 1—6.	1 Cor. i. 4—8.	2 Cor. ix. 6—11.
GOSPEL.	Luke xiv. 1—11.	Luke xiv. 1—11.	Matt. ix. 1—8.	

THE EIGHTEENTH SUNDAY AFTER TRINITY.

The Collect.

Gal. i. 3, 4.
1 Cor. x. 13.
Gal. v. 16, 17, 24.
Eph. vi. 11—13.
Matt. v. 8.
Eph. v. 1, 2, 10.

LORD, we beseech thee, grant thy people grace to withstand the temptations of the world, the flesh,

DOMINICA XVIII., POST TRINITATEM.

Oratio.

DA, quæsumus, Domine, populo tuo diabolica vitare contagia, et te solum Deum pura mente sectari. Per.

Salisbury Use.
Greg. Hebd. xxi.
post Pent.
Gelas. iii. 13. *et*
"puro corde."

INTROIT.—Be merciful unto me, O Lord, for I will call daily upon Thee. For Thou, Lord, art good and gracious, and of great mercy unto all them that call upon Thee. Ps. Bow down Thine ear, O Lord, and hear me, for I am poor and in misery. Glory be.

THE SEVENTEENTH SUNDAY AFTER TRINITY.

The idea of the Epistle and Gospel for this Sunday appears to be that of gaining liberty and victory through becoming the humble servants of Christ. St. Paul writes out of his prison, "I the prisoner of the Lord," as he writes in another place, "Remember my bonds:" and one who was in the bonds of an infirmity was brought to Christ, "and He took him, and healed him, and let him go," setting him free from his disease on the instant in a manner which cannot be explained by physiological science. Afterwards our Lord speaks of the humane work of setting free on the Sabbath an ox or an ass that had fallen into a pit; and of one being bidden to go up higher through his humility in taking the lowest room at a wedding feast. All these may be taken as illustrations of the way in which our Lord's service becomes perfect freedom to those who humbly take His yoke upon them. They offer also a further illustration of the principle stated in the end of the Epistle, "There is one body and one Spirit, even as ye are called in one hope of your calling; one Lord, one faith, one baptism, one God and Father of all, who is above all, and through all, and in you all." This principle is of a restrictive character: bringing the world out of a free worship of many gods to the worship of One; limiting it to one faith, and to one only means of initiation into the family of the one God. The idea conveyed is one of a bondage to rule and law which leaves

no room for invention or wild development and speculation. But, as Christ reigned from His Cross; as St. Paul governed the churches of Ephesus and other cities from his prison in Rome; as one who sits down in the lowest room will hear the Host say to him, "Friend, go up higher;" so limitations and restrictions of this kind are a means of real spiritual freedom, however much they may seem an irksome bondage to those who regard them superficially. The Christian who worships the One God is more free than the heathen who worshipped many; and the believer in a Faith once for all given is more free than he who is continually looking for new developments and open to the bondage of every novel speculation.

INTROIT.—Righteous art Thou, O Lord, and true is Thy judgment. O deal Thou with me according unto Thy mercy. Ps. Blessed are the undefiled in the way, who walk in the law of the Lord. Glory be.

THE EIGHTEENTH SUNDAY AFTER TRINITY.

Two comprehensive Christian formulæ are given in the Gospel and the Collect for this Sunday. That in the former sets forth the whole duty of the servant of Christ, "Thou shalt love the Lord thy God with all thy heart, and with all thy soul, and with all thy mind," and "thou shalt love thy neighbour as thyself." The formula of the English Collect is that familiar one of "the world, the flesh, and the devil," which represents all the temptations to which a Christian is liable. To these may also be added the words of the Epistle, "waiting for the coming of our Lord Jesus Christ," as an expression which comprehensively states the whole object of the Christian life. The duties, the difficulties,

and the devil, and with pure hearts
and minds to follow thee the only
God; through Jesus Christ our Lord.
Amen.

	<i>Modern English.</i>	<i>Salisbury Use.</i>	<i>Modern Roman.</i>	<i>Eastern.</i>
EPISTLE.	1 Cor. i. 4—8.	1 Cor. i. 4—8.	Eph. iv. 23—28.	2 Cor. xi. 31. xii. 9.
GOSPEL.	Matt. xxii. 34—46.	Matt. xxii. 34—46.	Matt. xxii. 1—14.	

THE NINETEENTH SUNDAY AFTER TRINITY.

The Collect.

John xv. 5.
Ps. cxliii. 10.
Heb. xlii. 20, 21.
1 Thess. v. 23.

O GOD, for as much as without thee we are not able to please thee; Mercifully grant, that thy Holy Spirit may in all things direct and rule our hearts; through Jesus Christ our Lord. *Amen.*

DOMINICA XIX., POST TRINITATEM.

Oratio.

DIRIGAT corda nostra, quæsumus, Domine, tuæ miserationis operatio; quia tibi sine te placere non possumus. Per Dominum nostrum.

Salisbury Use.
Greg. Hebd. xxii.
post Pent.
Gelas. iii. 14.

	<i>Modern English.</i>	<i>Salisbury Use.</i>	<i>Modern Roman.</i>	<i>Eastern.</i>
EPISTLE.	Eph. iv. 17—32.	Eph. iv. 23—28.	Eph. v. 15—21.	Gal. i. 11—19.
GOSPEL.	Matt. ix. 1—8.	Matt. ix. 1—8.	John iv. 46—53.	Luke v. 1—11.

THE TWENTIETH SUNDAY AFTER TRINITY.

The Collect.

Micah vii. 18.
Ps. xxxi. 19.
2 Thess. iii. 3.
Prov. xxx. 8, 9.
1 Cor. vi. 20.
Col. iii. 23.

O ALMIGHTY and most merciful God, of thy bountiful goodness keep us, we beseech thee, from all

DOMINICA XX., POST TRINITATEM.

Oratio.

OMNIPOTENS et misericors Deus, universa nobis adversantia propitiatus exclude; ut mente et corpore

Salisbury Use.
Greg. Hebd. xxiii.
post Pent.
Gelas. iii. 15.

and the purpose of the Christian life are thus made the subjects of commemoration and prayer; and the connexion of each with the grace of God and the Person of Christ is illustrated by the words of St. Paul in the Epistle, and of our Lord in His con-futation of the unbelievers as narrated in the Gospel.

INTROIT.—Give peace, O Lord, to them that wait for Thee, and let Thy prophets be found faithful. Hear the prayers of Thy servant, and of Thy people Israel. Ps. I was glad when they said unto me, We will go into the house of the Lord. Glory be.

THE NINETEENTH SUNDAY AFTER TRINITY.

The forsaking of sins, and the forgiveness of sins, are the sub-jects of the Epistle and Gospel for this Sunday. St. Paul writes to the Ephesians in much detail concerning the Christian moral law, and shows its relation to the newness of nature which belongs to those who are new born by Baptism into Christ. In the miracle by which our Blessed Lord restored to life the dead limbs of a paralytic this change from the old man to the new man is vividly illustrated. We also see in the circumstances attending this miracle two other illustrations of the relation between our Lord and His people. First, in His words, "Thy sins be forgiven thee," He shows that His forgiveness is the highest good that can be desired on earth; and that although He may also see fit to say, "Arise and walk," it is this blessing that is to be sought before all others. Secondly, His peculiar expression, "that the Son of man hath power on earth to forgive sins," shows that this power, which originates only in the God-head (as the Scribes truly thought), extended to the human nature

of our Lord, that sins might be forgiven *on earth* as well as at the last judgment before the throne of God. These words thus contain a statement of the whole principle of Absolution.

INTROIT.—I am the Saviour of My people, saith the Lord: out of whatsoever tribulation they call unto Me, I will hear them, and I will be their Lord for ever. Ps. Hear My law, O My people: incline your ears unto the words of My mouth. Glory be.

THE TWENTIETH SUNDAY AFTER TRINITY.

The prophetic parable of the Marriage Supper of the Only-begotten is the subject of the Gospel for this Sunday: and to it may be referred the words of the Collect, "that we, being ready both in body and soul, may cheerfully accomplish those things that Thou wouldest have done." The Epistle seems to be chosen as an illustration of the festivity of Christ's Kingdom, in which the sensual pleasures of heathen rites are superseded by the psalms and hymns and spiritual songs of Divine worship, which is chiefly made up of singing and making melody to the Lord, and is ever consecrated by the "giving of thanks," or offering of the Holy Eucharist, to God the Father, in the Name of our Lord Jesus Christ. Of this latter, as well as of the call of the Jews and the Gentiles, and the final marriage supper of the Lamb in Heaven, the Gospel ought to be interpreted; and it is so applied in the second Exhortation to the Holy Communion.

INTROIT.—In all the things that Thou hast brought upon us, O Lord, Thou hast executed true judgment; for we have sinned, and have not obeyed Thy commandments. Yet give glory to

things that may hurt us; that we, being ready both in body and soul, may cheerfully accomplish those things that thou wouldest have done; through Jesus Christ our Lord. *Amen.*

pariter expediti, quæ tua sunt liberis mentibus exequamur. Per Dominum.

	<i>Modern English.</i>	<i>Salisbury Use.</i>	<i>Modern Roman.</i>	<i>Eastern.</i>
EPISTLE.	Eph. v. 15—21.	Eph. v. 15—21.	Eph. vi. 10—17.	Gal. ii. 16—20.
GOSPEL.	Matt. xxii. 1—14.	Matt. xxii. 1—14.	Matt. xviii. 23—35.	Luke vi. 31—36.

THE ONE-AND-TWENTIETH SUNDAY AFTER TRINITY.

The Collect.

Ps. ciii. 8.
Heb. ix. 13, 14.
Isa. xxvi. 3.
Heb. x. 19—22.

GRANT, we beseech thee, merciful Lord, to thy faithful people pardon and peace, that they may be cleansed from all their sins, and serve thee with a quiet mind; through Jesus Christ our Lord. *Amen.*

DOMINICA XXI, POST TRINITATEM.

Oratio.

LARGIRE, quæsumus, Domine, fidelibus tuis indulgentiam placatus et pacem; ut pariter ab omnibus mundentur offensis, et secura tibi mente deserviant. Per.

Salisbury Use.
Greg. Hebd. xxiv.
post Pent.
Gelas. iii. 16.

	<i>Modern English.</i>	<i>Salisbury Use.</i>	<i>Modern Roman.</i>	<i>Eastern.</i>
EPISTLE.	Eph. vi. 10—20.	Eph. vi. 10—17.	Phil. i. 6—11.	Gal. vi. 11—18.
GOSPEL.	John iv. 46—54.	John iv. 46—53.	Matt. xxii. 15—21.	Luke viii. 5—8, 9—16.

THE TWO-AND-TWENTIETH SUNDAY AFTER TRINITY.

The Collect.

Eph. ii. 19.
2 Thess. iii. 3.
Ps. cxv. 2.
Heb. x. 24, xii. 28.
Phil. i. 9—11.

LORD, we beseech thee to keep thy household the Church in continual godliness; that through thy

DOMINICA XXII, POST TRINITATEM.

Oratio.

FAMILIAM tuam, quæsumus, Domine, continua pietate custodi; ut a cunctis adversitatibus te protegente

Salisbury Use
Greg. Superpopulum. Hebd. xxv.
post Pent.

Thy Name, and do to us according to the multitude of Thy mercies. Ps. Great is the Lord, and highly to be praised: in the city of our God, even upon His holy hill. Glory be.

THE TWENTY-FIRST SUNDAY AFTER TRINITY.

The connexion between the Epistle for this Sunday, which is that beautiful passage wherein St. Paul describes the whole armour of God, and the Gospel, in which is given the narrative of our Lord healing the nobleman's son, appears to lie chiefly in the words "above all taking the shield of faith." The hard, unimpressible generation of the Jews, among whom our Lord came, would not believe in "signs and wonders" on any evidence but that of their senses; and this placed a bar in the way of His blessing, so that He sometimes could not do mighty works among them, because there was no co-operation of faith on their part with power on His. The nobleman whose child was healed at a long distance by the will of Christ was a conspicuous illustration of the opposite type of character. He believed, in the face of all improbabilities, because he knew that the holy Jesus was not one to say that which was not true. To such minds Faith in Christ is a shield indeed against the fiery darts of the Wicked One; for their belief enables Him to do signs and wonders of a spiritual nature, and establishes a power of co-operation between the weak servant and the Almighty Lord. Thus not only is Faith a defence against the enemy of souls, but it draws down Christ Himself to be a "Defence and a Shield;" so that they can say, "The Lord is my Saviour, my God, and my might, in whom I

will trust, my buckler, the horn also of my salvation, and my refuge." As humble service of Christ is the most perfect freedom, because it frees from the bondage of the Evil One, so humble faith in Christ, the spirit which says not "seeing is believing," but, "Lord, I believe, help Thou mine unbelief," is the surest path to the revelation of the signs and wonders of His kingdom.

INTROIT.—O Lord, the whole world is in Thy power, and there is no man that can gainsay Thee. For Thou hast made heaven and earth, and all the wondrous things under the heaven. Thou art Lord of all. Ps. Blessed are the undefiled in the way, who walk in the law of the Lord. Glory be.

THE TWENTY-SECOND SUNDAY AFTER TRINITY.

Christian love is here, as on the first Sunday after Trinity, the subject of the Epistle and Gospel; but in the present instance it is illustrated by the tender words of St. Paul in his Epistle to the Philippians, and by our Lord's parable of the two debtors, which He spoke as a reply to St. Peter's question, "Lord, how oft shall my brother sin against me, and I forgive him?" This question was asked by one who was accustomed to the Jewish practice, which was ostentatious of its seven times' forgiveness, but yet unforgiving in reality. Our Lord's law of forgiveness had no limits, "Not until seven times, but until seventy times seven." The forgiveness of the debt of ten thousand talents represents the infinite mercy of God, and is given as the true Example and Standard towards which His absolved servants should reach upward.

protection it may be free from all adversities, and devoutly given to serve thee in good works, to the glory of thy Name; through Jesus Christ our Lord. *Amen.*

sit libera, et in bonis actibus tuo nomini sit devota. Per Dominum.

	<i>Modern English.</i>	<i>Salisbury Use.</i>	<i>Modern Roman.</i>	<i>Eastern.</i>
EPISTLE.	Phil. i. 3—11.	Phil. i. 6—11.	Phil. iii. 17—21.	Eph. ii. 4—10.
GOSPEL.	Matt. xviii. 21—35.	Matt. xviii. 23—35.	Matt. ix. 18—26.	Luke vii. 11—16.

THE THREE-AND-TWENTIETH SUNDAY AFTER TRINITY.

The Collect.

Ps. xlv. 1. 11.
2 Pet. i. 3.
Jer. xxix. 12—14.
Matt. xxi. 22.
vii. 11.
Phil. iv. 19.

O GOD, our refuge and strength, who art the author of all godliness; Be ready, we beseech thee, to hear the devout prayers of thy Church; and grant that those things which we ask faithfully we may obtain effectually; through Jesus Christ our Lord. *Amen.*

DOMINICA XXIII., POST TRINITATEM.

Oratio.

DEUS, refugium nostrum et virtus, adesto piis Ecclesie tue precibus, auctor ipse pietatis; et preesta, ut quod fideliter petimus, efficaciter consequamur. Per Dominum nostrum Jesum Christum.

Salisbury Use.
Greg. Hebd. xxvi.
post Pent.

	<i>Modern English.</i>	<i>Salisbury Use.</i>	<i>Modern Roman.</i>	<i>Eastern.</i>
EPISTLE.	Phil. iii. 17—21.	Phil. iii. 17—21.	[Next Sund. before Advent] Col. i. 9—14.	Eph. ii. 14—22.
GOSPEL.	Matt. xxii. 15—22.	Matt. xxii. 15—21.	Matt. xxiv. 15—35.	Luke viii. 27—39.

THE FOUR-AND-TWENTIETH SUNDAY AFTER TRINITY.

The Collect.

Num. xiv. 19.
Ps. cxix. 17. 68.
xl. 12, 13.
Lev. v. 17.

O LORD, we beseech thee, absolve thy people from their offences; that through thy bountiful goodness

DOMINICA XXIV., POST TRINITATEM.

Oratio.

ABSOLVE, quæsumus, Domine, tuorum delicta populorum; et a peccatorum nostrorum nexibus, quæ

Salisbury Use.
Greg. Hebd. xviii.
post Pent.

INTROIT.—If Thou, Lord, wilt be extreme to mark what is done amiss: O Lord, who may abide it? For there is mercy with Thee, O Lord God of Israel. Ps. Out of the deep have I called unto Thee; Lord, hear my voice. Glory be.

THE TWENTY-THIRD SUNDAY AFTER TRINITY.

Our Lord is set forth in the Gospel of this Sunday as teaching that duties towards the civil power are part of our heavenly citizenship; St. Paul also, in the Epistle, referring to the true Christian life on earth as having already many things in common with the life of heaven. None ever set a higher example of obedience to the laws than He Who is the Eternal Lawgiver and Ruler: and He inculcates an honest submission to them even in such a case as that on which an appeal was made to Him, where the law was that of a conqueror against whom rebellion seemed to be a duty. One deduction to be drawn from the words of Christ and of His Apostle is that the Church has little to do with politics or questions of secular government. The things of Cæsar and the things of God were confused together by the Jews, and they ended by rejecting the Lord, and saying, "We have no king but Cæsar." So it has happened at other times, that a want of zeal for God in carefully distinguishing what is His, has led the Church into bondage to civil rulers until its

spiritual character has been almost obliterated. The Church of England has been mercifully guided into a just discrimination of the things of Cæsar and the things of God; and while rendering strictest obedience to the Sovereign, has not suffered an excessive loyalty to yield up spiritual rights. Nor does it ever, in modern days, seek to interfere in matters of civil government. Such a just consideration of the respective duties which are owing towards Cæsar and towards God, and such a persevering determination to render to each their proper dues, is a sure way of promoting both the security and the happy progress of Christ's Church.

INTROIT.—I know the thoughts that I think towards you, saith the Lord; thoughts of peace, and not of evil. Ye shall call upon Me, and I will hearken unto you. I will turn away your captivity, and will gather you from among all nations. Ps. Lord, Thou hast become gracious unto Thy land; Thou hast turned away the captivity of Jacob. Glory be.

THE TWENTY-FOURTH SUNDAY AFTER TRINITY.

This Sunday offers another illustration of the faith of man co-operating with the will and power of Almighty God, in the two cases of the ruler whose young daughter was dead, and of the woman whose issue of blood was stayed through her faith in

Rom. vii. 18. 23
—25. vi. 15. 22,
23.

we may all be delivered from the bands of those sins, which by our frailty we have committed: Grant this, O heavenly Father, for Jesus Christ's sake, our blessed Lord and Saviour. *Amen.*

pro nostra fragilitate contraximus, tua benignitate liberemur. Per Dominum.

	<i>Modern English.</i>	<i>Salisbury Use.</i>	<i>Modern Roman.</i>	<i>Eastern.</i>
EPISTLE.	Col. i. 3—12.	Col. i. 9—11.	[As for one of the Sundays after Epiphany.]	Eph. iv. 1—7.
GOSPEL.	Matt. ix. 18—26.	Matt. ix. 18—22.		Luke xvi. 18—13.

THE TWENTY-FIFTH SUNDAY AFTER TRINITY.

The Collect.

Ps. cx. 3.
2 Pet. i. 13.
Phil. ii. 13.
John xv. 5. 8.
Gal. vi. 9.
2 Cor. ix. 6.

STIR up, we beseech thee, O Lord, the wills of thy faithful people; that they, plenteously bringing forth the fruit of good works, may of thee be plenteously rewarded; through Jesus Christ our Lord. *Amen.*

DOMINICA PROXIMA ANTE ADVENTUM.

Oratio.

EXCITA, quæsumus, Domine, tuorum fidelium voluntates; ut divini operis fructum propensius exequentes, pietatis tuæ remedia majora percipiant. Per Dominum nostrum.

Salisbury Use
Greg. Hebd.
xxvii. post
Pent.

	<i>Modern English.</i>	<i>Salisbury Use.</i>	<i>Modern Roman.</i>	<i>Eastern.</i>
EPISTLE.	Jer. xxiii. 5—8.	Jer. xxiii. 5—8.	[As for one of the Sundays after Epiphany.]	
GOSPEL.	John vi. 5—14.	John vi. 5—14.		

¶ If there be any more Sundays before Advent-Sunday, the service of some of those Sundays that were omitted after the Epiphany shall be taken in to supply so many as are here wanting. And if there be fewer, the overplus may be omitted: Provided that this last Collect, Epistle, and Gospel shall always be used upon the Sunday next before Advent.

touching the hem of our Lord's garment. "My daughter is even now dead," said the former, "but come and lay Thy hand upon her, and she shall live:" "If I may but touch His garment," said the latter, "I shall be whole." These instances of recovery from disease and death are devotionally applied in the Collect: where the expressive phrase, "the bands of those sins, which by our frailty we have committed," has a double reference: first, to the bondage of sin in its spiritual sense; and, secondly, to the physical evils which bind us around with chains that are forged by sin.

INTROIT.—I know the thoughts that I think towards you, saith the Lord; thoughts of peace, and not of evil. Ye shall call upon Me, and I will hearken unto you. I will turn away your captivity, and will gather you from among all nations. Ps. Lord, Thou hast been gracious unto Thy land; Thou hast turned away the captivity of Jacob. Glory be.

THE SUNDAY NEXT BEFORE ADVENT.

In St. Jerome's Lectionary twenty-five Sundays after Pentecost are provided with Epistles and Gospels. In the Sacramentary of St. Gregory there are Collects for twenty-seven Sundays. In the Salisbury Missal twenty-four Sundays were reckoned as after Trinity, and one as the next before Advent: and there was a rubric directing that if there were more than twenty-five Sundays between Trinity Sunday and Advent Sunday, the Office for the Twenty-fourth Sunday was to be repeated on each Sunday until the last, when that for the Sunday before Advent was to be said. In the Prayer Book of 1549 no rubric of this kind was provided, but the old usage would, doubtless, be adopted. In 1552, however, a rubric was inserted to this effect:—"¶ If there be any more Sundays before Advent Sunday, to supply the same

shall be taken the Service of some of those Sundays that were omitted between the Epiphany and Septuagesima." This rubric was altered into its present form in the Durham book of Bishop Cosin, having already appeared in a similar but more cumbersome form in 1637.

If there are two of these *Dominicæ Vagantes* (as they were anciently called), the Services for the fifth and sixth Sundays after Epiphany should be used; if only one, that for the sixth Sunday, which has evidently been appointed with a view to its fitness for use on the Sunday next but one to Advent. The rule expressed in this rubric is a very ancient one, being found in Micrologus, c. 62.

The Office of this day represents that for the fifth Sunday before the Nativity of our Lord in the Comes of St. Jerome, which appoints the same Epistle and Gospel, and in the Sacramentary of St. Gregory, though a different Collect is appointed for that day in the latter. Its tone is that of Advent rather than Trinity, commemorating as it does the first coming of the King whose Name is "The Lord our Righteousness," and looking forward to that second coming when the true restoration of Israel will be effected. The Gospel is the same as that for Mid-Lent Sunday, where some notes upon it will be found. The rationale of its appointment for to-day is to be found in the last words of it,—“This is of a truth that Prophet that should come into the world.”

INTROIT.—I know the thoughts that I think towards you, saith the Lord; thoughts of peace, and not of evil. Ye shall call upon Me, and I will hearken unto you. I will turn away your captivity, and will gather you from among all nations. Ps. Lord, Thou art become gracious unto Thy land; Thou hast turned away the captivity of Jacob. Glory be.

SAINT ANDREW'S DAY.

The Collect.

[A.D. 1652.]
John i. 35-37.
40.
Mark i. 16-18.
Rom. i. 5, 6.
1 John iii. 2, 3.
Matt. xvi. 2, 4.
xix. 17.
John xiv. 15.

ALMIGHTY God, who didst give such grace unto thy holy Apostle Saint Andrew, that he readily obeyed the calling of thy Son Jesus Christ, and followed him without delay; Grant unto us all, that we, being called by thy holy word, may forthwith give up our selves obediently to fulfil thy holy commandments; through the same Jesus Christ our Lord. *Amen.*

DIES SANCTI ANDREÆ.

Salisbury Use.

ALMIGHTY God, which hast given such grace to thy Apostle Saint Andrew, that he counted the sharp and painful death of the cross to be an high honour and a great glory: Grant us to take and esteem all troubles and adversities which shall come unto us for thy sake as things profitable for us toward the obtaining of everlasting life: through Jesus Christ our Lord.]

Common Prayer Book of 1549. [Also in Latin book of 1560.]
Cf. Præfat. in Greg. Nat. S. Andree.

	<i>Modern English.</i>	<i>Salisbury Use.</i>	<i>Modern Roman.</i>	<i>Eastern.</i>
EPISTLE.	Rom. x. 9-21.	Rom. x. 9-18.	Rom. x. 10-18.	1 Cor. iv. 9-16.
GOSPEL.	Matt. iv. 18-22.	Matt. iv. 18-22.	Matt. iv. 18-22.	John i. 35-51.

SAINT ANDREW.

[NOVEMBER 30.]

The feast of St. Andrew is one of those for which an Epistle and Gospel are provided in the Lectionary of St. Jerome, and which has also prayers appointed for it in the Sacramentary of St. Gregory. It is therefore of very ancient date in the Church, and one of the most ancient of the Apostles' festivals, only nine being named (on six days) in the Lectionary referred to. Its position may be at the beginning or at the end of the Christian year, according as Advent Sunday happens in November or December. It has usually been considered that it comes at the beginning, and that it is placed there because the Apostle thus commemorated was the first called disciple of our Lord; but tradition points out the day as that of his death.

It may be remarked here, as applicable to all the Apostles, that little has been told us of any except St. Peter and St. Paul in Holy Scripture; and that what has come down to us in uninspired history does not throw much more light upon their personal character or the details of their work. The latter fact may, perhaps, be accounted for from the circumstance that most of the Apostles, except St. Peter, St. Paul, and St. John, laboured among nations of whose records, previous to the quiet settlement of the Church, nothing, or next to nothing, remains; and that in the wild and lawless times which accompanied the breaking up of the Roman Empire, even lingering traditions about them would pass away. With respect to the paucity of details given about the Apostles in the New Testament, there seem to be two reasons which offer a sufficient explanation. For (1) the purpose of Holy Scripture is to set before us the Person of Christ, and the Law of Christ; and whatever else enters into the four Gospels is merely incidental; and (2) in the Acts of the Apostles the object is to show the work of the Church, and not to give us the history of individuals; so that the latter also is merely incidental.

Hence, probably, the reason why we gather hardly any particulars from Scripture about the life of St. Andrew. He was a brother of St. Peter, and therefore a son of Jonas or John; and probably younger than St. Peter. The ancients used to give him the surname of Protocletos, or First-called, from the circumstances told us in St. John i. 40-42; and, having been a disciple of John the Baptist, he was one of those who were prepared to receive Christ by the teaching and Baptism of His Forerunner. There are only two other circumstances of his life mentioned in the Gospels: the first in St. John xii. 21, where it is St. Andrew and St. Philip who tell Jesus of the inquiring Greeks; and the

second in St. Mark xiii. 3, where Andrew and his brother, with the two sons of Zebedee, are found in close companionship with the Lord, asking Him privately respecting the time when Jerusalem should be destroyed.

Ecclesiastical history records that this Apostle was engaged after the dispersion of the Apostles in evangelizing that part of the world which is now known as Turkey in Asia, and the portion of Russia which borders on the Black Sea: and indeed that he was the first founder of the Russian Church, as St. Paul was of the English Church. Sinope and Sebastopol are both especially connected with the name of St. Andrew. In his later days he returned to Europe, consecrated the "beloved Stachys," first Bishop of Constantinople—then named Byzantium—and after travelling about Turkey in Europe, eventually suffered martyrdom at Patras, a town in the north of the Morea, nearly opposite to Lepanto.

The account of this Apostle's martyrdom is very affecting. At a great age he was called before the Roman viceroy at Patras (now Patras), and required to leave off his Apostolic labours among the heathen Greeks. Instead of consenting, he proclaimed Christ even before the judgment-seat; and after imprisonment and submitting patiently to a seven times repeated scourging upon his bare back, he was at last fastened to a cross by cords, and so left exposed to die. The cross on which he suffered was of a different form from our Lord's, like this X^c, and is known by the name of the *cross decussate*. It is the distinctive symbol of the Scotch order of St. Andrew: the Apostle being always especially revered in connexion with the Scottish, as with the Russian Church; and consequently forms a part of the national banner of Great Britain. It has also been observed that it is an integral part of the monogram of Christ X^c, which was so familiar to the early Christians.

"Hail, precious cross!" said the aged Apostle, as he came to it, "that hast been consecrated by the Body of my Lord, and adorned with His limbs as with rich jewels. I come to thee exulting and glad; receive me with joy into thy arms. Oh, good cross, that hast received beauty from our Lord's limbs! I have ardently loved thee; long have I desired and sought thee; now thou art found by me, and art made ready for my longing soul; receive me into thy arms, taking me from among men, and present me to my Master, that He Who redeemed me on thee may receive me by thee." For two days the dying martyr exhorted the people from the cross after His example Who stretched out His arms all the day long to an ungodly and gainsaying people.

SAINT THOMAS THE APOSTLE.

The Collect.

[A. D. 1549.]
 Heb. xi. 6.
 John xx. 24—31
 1 Pet. ii. 6.
 John iii. 18, vi.
 69. xiv. 13, 14.
 Eph. ii. 18.

ALMIGHTY and everliving God,
 who for the more confirmation of
 the faith didst suffer thy holy Apostle
 Thomas to be doubtful in thy Son's
 resurrection; Grant us so perfectly,
 and without all doubt to believe in
 thy Son Jesus Christ, that our faith
 in thy sight may never be reprov'd.
 Hear us, O Lord, through the same
 Jesus Christ, to whom, with thee and
 the Holy Ghost, be all honour and
 glory, now and for evermore. *Amen.*

DIES SANCTI THOMÆ APOSTOLI.

Salisbury Use.

	<i>Modern English.</i>	<i>Salisbury Use.</i>	<i>Modern Roman.</i>	<i>Eastern.</i>
EPISTLE.	Eph. ii. 19—22.	Eph. ii. 19—22.	Eph. ii. 19—22.	Acts v. 12—20.
GOSPEL.	John xx. 24—31.	John xx. 24—29.	John xx. 19—31.	John xx. 9—31.

At the end of that time he prayed to the Crucified One that he might now depart in peace, when his prayer was heard, and his spirit went home on the day observed as his festival, A. D. 70.

INTROIT.—Thy friends are exceeding honourable unto me, O God: greatly is their beginning strengthened. Ps. O Lord, Thou hast searched me out and known me: Thou knowest my downsitting and mine uprising. Glory be.

HYMNS.

EVENSONG.—*Annue, Christe.* H. N. 86. 75.

COMPLINE.—*Salvator mundi, Domine.* H. A. M. 49., C. H. 24.

MATTINS.—*Annue, Christe.* H. N. 86. 75.

LAUDS.—*Exultet cœlum laudibus.* A. A. 188.

These hymns are appointed to be sung on all Feasts of Apostles and Evangelists throughout the year, except when superseded by the Paschal or other proper hymns.

SAINT THOMAS.

[DECEMBER 21.]

The Festival of St. Thomas the Apostle is not noticed by any writer until Theodoret, who names it with that of St. Peter and St. Paul. [De Græc. Affect. vii.] It seems to have been generally observed in the time of St. Gregory, who has provided for it in his Sacramentary. In the Eastern Church it is kept on October 6th. Although our Collect is not derived from that source, the leading idea of it is found in a Homily of St. Gregory [Hom. in Evang. 26], where he says, that "by this doubting of St. Thomas we are more confirmed in our belief than by the faith of the other Apostles."

There are but four sayings of St. Thomas recorded in the Gospels, two just before the death of our Lord, and two just after His Resurrection; but there is a remarkable consistency in these sayings, one in each case showing want of faith, and the other a warm, zealous, and faithful love. These sayings are as follows:—

"Lord, we know not whither Thou goest; and how can we know the way?" John xiv. 5.

"Let us also go, that we may die with Him." John xi. 16.

"Except I shall see in His hands the print of the nails, and put my finger into the print of the nails, and thrust my hand into His side, I will not believe." John xx. 25.

"My Lord, and my God." John xx. 28.

In these four sayings we have all that Holy Scripture tells us of the Apostle's companionship with our Lord; but they seem to

give more than the outline of a spiritual character in which there were the mingled elements of (1) obstinacy, in not believing, though prophets had foretold of the Resurrection, and the other Apostles were eye-witnesses of its certainty; (2) presumption, in requiring such a proof, even perhaps in the face of the "Touch Me not," which had been made known by Mary Magdalen; (3) of a warm and loving heart, open to the strongest faith as well as to despairing doubt; and which could lead the Apostle to that full confession of faith contained in the words, "My Lord, and my God." But it may have been the touch of Christ's wounds which healed the Apostle's doubt, and made his faith what it was.

It was not granted to St. Thomas to have his loving and courageous aspiration fulfilled, by dying with Christ, but the servant followed the Master afterwards. It is recorded by Eusebius, that he received a direction from our Lord, after His Ascension (as St. Peter in the case of Cornelius), to send Thaddeus, one of the seventy disciples, to Abgarus, tributary king of Edessa in Mesopotamia, who was thus miraculously cured of a disease, and converted, with his subjects, to Christianity. After this St. Thomas went to the Parthians, Medes, Persians, and Chaldeans, founding the Church of Christ among them until he came to India. The Christians of St. Thomas still bear witness to his work in that great and populous land in the south, and in the north there appear to be relics of the Christian faith mixed up with the strange religion of Thibet; but the diabolical systems of Brahma and Buddha, and the Antichristianism of Mahomet, have long ago erased all other traces of it; and India appears to be one of those unhappy countries which, having wilfully rejected the Apostolic ministry, have ceased to be capable of receiving Christ and His Gospel.

St. Thomas was martyred by the Brahmins at Taprobane, now called Sumatra. Having been assailed with stones, he was at last killed by the thrust of a spear: the manner of his death offering a striking comparison with his words, "Except I thrust my hand into His side," and those of our Lord, "Reach hither thy hand, and thrust it into My side, and be not faithless, but believing." As the Lord said to St. Peter, so were the words true of St. Thomas, "Thou canst not follow Me now, but thou shalt follow Me afterwards."

INTROIT.—Thy friends are exceeding honourable unto me, O God: greatly is their beginning strengthened. Ps. O Lord, Thou hast searched me out and known me: Thou knowest my downsitting and mine uprising. Glory be.

THE CONVERSION OF SAINT PAUL.

The Collect.

Col. i. 5, 6.
Acts xxvi. 9—20.
Rom. xv. 15—17.
Acts xx. 20, 21.
27.
Col. ii. 6.
1 Thess. iv. 1, 2.

O GOD, who, through the preaching of the blessed Apostle Saint Paul, hast caused the light of the Gospel to shine throughout the world; Grant, we beseech thee, that we, having his wonderful conversion in remembrance, may shew forth our thankfulness unto thee for the same, by following the holy doctrine which he taught; through Jesus Christ our Lord. *Amen.*

IN CONVERSIONE SANCTI PAULI,

Oratio.

DEUS, qui universum mundum beati Pauli Apostoli tui prædicatione docuisti: da nobis, quæsumus, ut qui ejus hodie conversionem colimus: per ejus ad te exempla gradiamur. Per Dominum.

Salisbury Use.
Greg. Conv.
S. Pauli. Cf.
Officium Sar.

	<i>Modern English.</i>	<i>Salisbury Use.</i>	<i>Modern Roman.</i>	<i>Eastern.</i>
EPISTLE.	Acts ix. 1—22.	Acts ix. 1—22.	Acts ix. 1—22.	
GOSPEL.	Matt. xix. 27—30.	Matt. xix. 27—30.	Matt. xix. 27—29.	

THE PRESENTATION OF CHRIST IN THE TEMPLE, COMMONLY CALLED, THE PURIFICATION OF SAINT MARY THE VIRGIN.

The Collect.

Ps. cii. 24—27.
Hag. ii. 7—9.
Luke ii. 22—30.
Gal. iv. 4.
Matt. v. 8.
Ps. xxiv. 3, 4.
Rev. i. 3, 6.

ALmighty and everliving God, we humbly beseech thy Majesty, that, as thy only-begotten Son was this day presented in the temple in

IN PURIFICATIONE BEATÆ MARÆ VIRGINIS,

Oratio.

OMNIPOTENS sempiternæ Deus, Majestatem tuam supplices exoramus, ut sicut unigenitus Filius tuus hodierna die cum nostræ carnis sub-

Salisbury Use.
Greg. Purif.
S. Mariæ V.

CONVERSION OF SAINT PAUL.

[JANUARY 25.]

This festival does not appear to have been generally observed until about the twelfth century, although the Collect for it is found in St. Gregory's Sacramentary. It is said [Laterculum of Silvius, A.D. 448] that there was anciently a festival of St. Peter and St. Paul on February 22nd (now "Cathedra Petri"), and there may have been some connexion between it and the present festival, but this is only conjecture. The principal, if not the only, day observed to the honour of St. Paul, was that on which St. Peter was associated with him, the 29th of June; although, on the following day, a "Commemoration of St. Paul" was made, which is marked in the Salisbury and Roman Calendars, and mentioned in the Rubrics of the Missal; and which, in Menard's edition of St. Gregory's Sacramentary, is called "Natale Sancti Pauli." It is a pious instinct which has led the Church to thank God in this festival for the wonderful conversion of the Apostle of the Gentiles; but there is something to regret in the loss of the ancient custom by which his noble martyrdom was also commemorated, and by which the unity of the two principal Apostles was so significantly set forth.

Both the conversion and the missionary work of St. Paul are narrated with much detail in the Acts of the Apostles; and the whole of his life and labours has been minutely investigated in the well-known work of Conybeare and Howson. To attempt even a sketch of so marvellous a career in these notes would be to occupy space that cannot be spared; and such a sketch is rendered unnecessary by the elaborate but yet very accessible work just mentioned.

INTROIT.—Let us all rejoice in the Lord, commemorating this day, the day in which the blessed St. Paul adorned the world by his conversion. Ps. For the conversion of the blessed St.

Paul, and for the bright beams of light shed by his preaching, Glory be.

THE PURIFICATION.

[FEBRUARY 2.]

This festival has the same Epistle and Gospel which are now in use appointed for it in the Lectionary of St. Jerome, and the germ of the present Collect is found in the Sacramentary of Gelasius¹. St. Cyril of Alexandria, and others of an equally early date refer to it; and there is little doubt that it was the first festival instituted in memory of the Blessed Virgin. The ancient and present name for it in the Eastern Church is the Hypapante of our Lord Jesus Christ; that is, the *ἵναρη* or *ἱναρανθή*, the meeting of our Lord with Simeon and Anna in the Temple. It is said to have been observed on the 14th day of February until the time of Justinian [A.D. 542], but in the Comes of St. Jerome it precedes the festival of St. Agatha, which is dated on the Nones, or 5th of February, the day on which that Saint is still commemorated; and probably it was so observed only by those who kept Christmas Day on the 6th of January, as a part of the Eastern Church has always done.

The popular name of this festival (Candlemas Day) perpetuates the memory of a very ancient custom, that of walking in procession with tapers, and singing hymns. In a Homily on the Purification Alcuin says [A.D. 790], "The whole multitude of the city collecting together devoutly celebrate the solemnity of the Mass, bearing a vast number of wax lights; and no one enters any public place in the city without a taper in his hand." St. Bernard also [A.D. 1153] gives the following description of the practice, as carried out in his day:—

¹ Until 1661 the Epistle was that for the Sunday. Bishop Cosin introduced the one now used. He also prefixed the first title to the day.

substance of our flesh, so we may be presented unto thee with pure and clean hearts, by the same thy Son Jesus Christ our Lord. *Amen.*

stantia in templo est præsentatus, ita nos facias purificatis tibi mentibus præsentari. Per eundem.

	<i>Modern English.</i>	<i>Salisbury Use.</i>	<i>Modern Roman.</i>	<i>Eastern.</i>
EPISTLE.	Mal. iii. 1—5.	Mal. iii. 1—4.	Mal. iii. 1—4.	Heb. vii. 7—17.
GOSPEL.	Luke ii. 22—40.	Luke ii. 22—32.	Luke ii. 22—32.	Luke ii. 22—40.

SAINT MATTHIAS' DAY.

The Collect. •

[A.D. 1549.]
Acts i. 20—26.
John xvii. 11, 12.
20.
2 Pet. ii. 1.
Eph. iv. 11, 12.
Heb. v. 4, 5.

O ALMIGHTY God, who into the place of the traitor Judas didst choose thy faithful servant Matthias to be of the number of the twelve Apostles; Grant that thy Church, being alway preserved from false Apostles, may be ordered and guided by faithful and true pastors; through Jesus Christ our Lord. *Amen.*

SANCTUS MATTHIAS APOSTOLUS. *Salisbury Use.*

	<i>Modern English.</i>	<i>Salisbury Use.</i>	<i>Modern Roman.</i>	<i>Eastern.</i>
EPISTLE.	Acts i. 15—26.	Acts i. 15—26.	Acts i. 15—26.	Acts i. 12—17. 21—26.
GOSPEL.	Matt. xi. 25—30.	Matt. xi. 25—30.	Matt. xi. 25—30.	Luke x. 16—21.

“We go in procession, two by two, carrying candles in our hands, which are lighted, not at a common fire, but at a fire first blessed in the church by a Bishop. They that go out first return last; and in the way we sing, ‘Great is the glory of the Lord.’ We go two by two in commendation of charity and a social life; for so our Saviour sent out His disciples. We carry lights in our hands; first, to signify that our light should shine before men; secondly, this we do this day especially in memory of the Wise Virgins (of whom this blessed Virgin is the chief) that went to meet their Lord with their lamps lit and burning. And from this usage and the many lights set up in the church this day, it is called Candelaria, or Candlemas. Because our works should be all done in the holy fire of charity, therefore the candles are lit with holy fire. They that go out first return last, to teach humility, ‘in honour preferring one another.’ Because God loveth a cheerful giver, therefore we sing in the way. The procession itself is to teach us that we should not stand idle in the way of life, but ‘go from strength to strength,’ not looking back to that which is behind, but reaching forward to that which is before.”

The festival is placed at forty days’ distance from Christmas, as that was the interval directed by the law between the day of birth and the day when the mother presented herself for readmission to the congregation, and her infant son for an offering to the Lord. [Lev. xii. 4. Exod. xxii. 29. Num. viii. 17.] It was on this occasion that Simeon gave to the Church the *Nunc Dimittis*, in which he proclaimed the glorious and universal Epiphany of the Holy Child, when he prophesied of Him as “a Light to lighten the Gentiles, and the glory of God’s people Israel.” It was then also that the Virgin, Mother first learned that sorrow as well as joy was in the wonderful lot assigned her: “Yea, a sword shall pierce through thy own soul also.”

The submission of the Blessed Virgin to the ceremony of purification, and of her Divine Son to that of presentation in the Temple, were each of them an illustration of the perfect humilia-

tion of our Lord to the likeness of sinful man. The miraculous conception of the Virgin had been unattended by that for which a ceremonial purification was ordained; and our Blessed Lord, having no original sin, needed not to be offered (or presented) and bought back again. But, as at His Baptism, so now, for Himself and for His holy Mother He says by their acts, “Suffer it to be so now, for thus it becometh us to fulfil all righteousness.” In the price of redemption (the representative sacrifice offered in the early dawn of the Holy Child’s life, to be followed by a more perfect Sacrifice in its eventide) it has been noticed that there was a typical meaning, now for the first and only time finding its true signification. The two turtle-doves, or young pigeons, were expressive of lowliness at all times, as offerings of the poor; but in the offering of one by fire, and the eating of the other by the priest, or those who offered it, are now to be seen a type of Christ offering Himself for sin, and also giving Himself to be the spiritual food and sustenance of His people.

It is worthy of remark, as a happy token of the unity which is possible in spite of disagreement, that although the *cultus* of the Blessed Virgin was and is one principal cause of difference between the Church of England and other Catholic Churches of Europe, yet we retain old Collects for both the Annunciation and the Purification, while nearly all the other Saints’-day Collects are modern.

INPROFIT.—We wait for Thy loving-kindness, O God: in the midst of Thy temple. O God, according to Thy Name, so is Thy praise unto the world’s end: Thy right hand is full of righteousness. Ps. Great is the Lord, and highly to be praised: in the city of our God, even upon His holy hill. Glory be.

SAINT MATTHIAS.

[FEBRUARY 24.]

This is not one of the most ancient of the festivals generally observed by the Church, as there is no provision for it in the

THE ANNUNCIATION OF THE BLESSED VIRGIN MARY.

The Collect.

Heb. xiii. 9.
Rom. i. 3, 4.
Matt. i. 18—21.
Heb. ii. 9, 10.
Phil. iii. 8, 10,
11, 20, 21.

WE beseech thee, O Lord, pour thy grace into our hearts; that, as we have known the incarnation of thy Son Jesus Christ by the message of an angel, so by his cross and passion we may be brought unto the glory of his resurrection; through the same Jesus Christ our Lord. *Amen.*

IN ANNUNCIATIONE BEATÆ MARIE,

Postcommunio.

GRATIAM tuam, quæsumus, Domine, mentibus nostris infunde: ut qui angelo nuntiante Christi Filii tui incarnationem cognovimus, per passionem ejus et crucem ad resurrectionis gloriam perducamur. Per eundem.

Salisbury Use.
Greg. super
Oblata. Ann.
Angeli ad B.
Mariam.

LORD, we bisechen helde yn thi grace to oure inwittis, that bi the message of the aungel we knowe the incarnacioun of thi sone iesu crist, and by his passioun and cross be ledde to the glorie of his resurreccioun. Bi the same iesu crist oure lord, that with thee lyueth and regneth in oonhede of the hooly goost, god, bi alle worldis of worldis. So be it.

XIVth century
Prymer ver-
sion.

	<i>Modern English.</i>	<i>Salisbury Use.</i>	<i>Modern Roman.</i>	<i>Eastern.</i>
EPISTLE.	Isa. vii. 10—15.	Isa. vii. 10—15.	Isa. vii. 10—15.	Heb. ii. 11—18.
GOSPEL.	Luke i. 26—38.	Luke i. 26—38.	Luke i. 26—38.	Luke i. 24—33.

lectionary of St. Jerome; but there is a Collect for it in the Sacramentary of St. Gregory, and in a German martyrology of about the same period. It comes first in order after the Festivals of the Incarnation, perhaps because St. Matthias represents the earliest independent action of the Church as that spiritual body which was to exercise the authority of Christ, and to become the substitute, in some measure, for His Visible Presence. But in the Eastern Church it is August 9th.

St. Matthias' Day was formerly changeable in Leap Year, when the intercalated day was added between February 23rd and 24th, and the 25th became the festival of St. Matthias. But at the revision of the Calendar in 1661, the intercalary day was placed at the end of the month, and the festival of St. Matthias fixed permanently to the 24th day. This is the day (VI. Kalend. Martii) appointed for the Festival in the Sacramentary of St. Gregory.

Nothing more is recorded of St. Matthias in the New Testament than that he was chosen to be an Apostle in the place of Judas Iscariot, the account of his Ordination to that high Office being given in Acts i. 15—26, the Epistle of the day throughout the world. The Eastern Gospel contains the same solemn prayer of our Lord as that does which is used in the Western Church, though taken from a different Evangelist; and the coincidence is a striking illustration of the unity of mind by which the whole Catholic Church is pervaded. It is plain also that this Gospel is intended to show that the Apostle, on whose day it is used, was as much "numbered with" the other Apostles, although ordained by men, as any of those were who were ordained by our Lord Himself; and thus illustrates the great truth, that the Great High Priest Himself declared, "As My Father hath sent Me, even so send I you."

The tradition of the Church respecting St. Matthias' Apostolic labours is, that after ministering for some years among his countrymen the Jews, he went to Cappadocia, and was eventually crucified there about the year of our Lord 64. The manner of his death was not very unlike that of the traitor Judas, but the

one found the tree on which he hung the way "to his own place;" the other, his Master's own road to the Paradise of God.

INTROIT.—Thy friends are exceeding honourable unto me, O God: greatly is their beginning strengthened. Ps. O Lord, Thou hast searched me out and known me: Thou knowest my downsitting and mine uprising. Glory be.

THE ANNUNCIATION.

[MARCH 25.]

There is no mention of the festival of the Annunciation in the Lectionary of St. Jerome, although there are days in honour of the Purification and the Nativity and the Death or Assumption of the Blessed Virgin. It is however of very early date, as Proclus, patriarch of Constantinople, who died A.D. 446, has left a Homily on the day, which was preached in the presence of Nestorius, and against his heresy. It is also mentioned by St. Athanasius, St. Chrysostom, St. Augustine, and other writers as early; and the Collect is found in the Sacramentary of Gelasius, at the end of the fifth century, as well as in that of St. Gregory. In the Council of Toledo, A.D. 656, the first of seven Canons orders that the feast of the Annunciation shall, in future, be kept on the 18th of December, so as not to interfere with the celebration of Good Friday or the observance of Lent. But this day was afterwards appropriated to the festival named "the Expectation of the Blessed Virgin," and the old day was restored.

In the Consuetudinary of Sarum this festival is called "Our Lord's Annunciation," and Bishop Cosin proposed to alter the title both here and in the Table of Lessons to "The Annunciation of our Lord to the Blessed Virgin Mary" in both cases his alteration was rejected, and the authorized title is "The Annunciation of our Lady," or "The Annunciation of the Blessed Virgin Mary."

SAINT MARK'S DAY.

The Collect.

2 Tim. iv. 11.
1 Pet. i. 12.
Eph. iv. 11, 12.
14, 15.
1 Pet. v. 10.
Heb. xlii. 9.

O ALMIGHTY God, who hast instructed thy holy Church with the heavenly doctrine of thy Evangelist Saint Mark; Give us grace, that, being not like children carried away with every blast of vain doctrine, we may be established in the truth of thy holy Gospel, through Jesus Christ our Lord. *Amen.*

SANCTUS MARCUS EVANGELISTA.

Oratio.

DEUS, qui beatum Marcum evangelistam tuum evangelicæ prædicationis gratia sublimasti: tribue, quæsumus, ejus nos semper et eruditione perficere et oratione defendi. Per Dominum.

Salisbury Use.
Greg. Nat.
S. Marc. Ev.

	<i>Modern English.</i>	<i>Salisbury Use.</i>	<i>Modern Roman.</i>	<i>Eastern.</i>
EPISTLE.	Eph. iv. 7—16.	Eph. iv. 7—16.	Ezek. i. 10—14.	1 Pet. v. 6—14.
GOSPEL.	John xv. 1—11.	John xv. 1—7.	Luke x. 1—9.	Luke x. 16—21.

The Church of England commemorates the Mother of our Lord on five days in the year, the Annunciation, the Purification, the Visitation, the Nativity of the Blessed Virgin, and her Conception. The three latter are Black Letter Days in July, September, and December: the two former, as days which commemorate events that associated her with the Person of our Lord and the work of our salvation by His human Nature, are provided with special services as days of obligation:

If our Blessed Lord's Nativity occurred on the 25th of December, as there are sound chronological reasons for supposing, this may be taken as the true time when the angel Gabriel first gave to the Church the words, "Hail, thou that art highly favoured, the Lord is with thee: blessed art thou among women;" words which have been associated with errors in doctrine and practice, but which are still words that come from God. It must have been about this time also, "in those days," that the Blessed Virgin was inspired to give to the Church the Canticle which has ever since been so dear to every generation. The words which she was thus inspired to speak respecting herself, and those which were spoken of her by the angel "sent from God," show to what an exalted place she was raised by the Providence of Almighty God: and her meek reception of the wonderful revelation shows a holiness in the subjection of her will to the will of the Lord, Whose handmaid she was, that no saint ever surpassed. Holy in her original character, her holiness was made more perfect by that most intimate union with Jesus which existed for nine months of her life. Little children were brought to Jesus that He might lay His hands on them, and thus sanctify them by the touch of a passing moment; but the same Jesus abode long in His Mother's bosom, His spotless Body was formed of her substance, and sanctified her both in what He received from her as Man, and what He gave to her as God. Not even when she was in Paradise could have been so holy as the Virgin Mary when she became a Paradise herself. Not even the glorified saints who have attained to the purity and bliss of Heaven are raised to higher blessedness and purity than that saintly maiden whom Elizabeth was inspired to speak of as "the Mother of my Lord."

This sanctity of the Blessed Virgin Mary through her association with her Divine Son has always been kept vividly in view by the Church: but, while excess of sentiment on the one hand has led to an irreverent dishonour of her name by associating it with attributes of Deity, so want of faith in the principle of the Incarnation has led, on the other hand, to an irreverent depreciation of her sanctity. Our two principal and three minor festivals in honour of the Virgin and her work in the Incarnation point out the true course; to esteem her very highly above all other saints; but yet so that her honour may be to the glory of God.

INTROIT.—Drop down, ye heavens, from above, and let the

skies pour down righteousness; let the earth open, and let it bring forth salvation. [Alleluia. Alleluia.—If in Easter season.] Ps. And let righteousness spring up together; I the Lord have created it. Glory be.

SAINT MARK.

[APRIL 25.]

The festival of St. Mark is provided for in the Sacramentary of St. Gregory, although not in the Comes of St. Jerome. Like others, it probably began in a local observance by the Church of a particular country, (in this case, Egypt,) and was gradually extended to all other Churches throughout the world.

Of the Saint commemorated on this day there can be no doubt; but it is not quite certain which of the Marks named in the Acts of the Apostles is Saint Mark the Evangelist. It seems most probable that he was not the John Mark of Acts xii. 12, and Acts xv. 37, (who was the nephew of St. Barnabas, and about whose conduct the sharp dissension arose between St. Paul and St. Barnabas,) but that the Evangelist was the "Marcus, my son," of whom St. Peter writes, in 1 Pet. i. 13, as being his companion at Babylon. It was his association with St. Peter which led St. Mark to be the writer of the Gospel which goes by his name, and which is always connected with the name of St. Peter as well as of St. Mark by ancient writers. The later years of his ministry were spent at Alexandria, where he founded the Church of Christ among the intellectual men of that learned city, and originated among them that class of Christian scholars which afterwards gave such a prominent place to Alexandria in the theological history of the Church. The Evangelist carried the knowledge of Christ and the ministry of the Church into less civilized parts of Africa, but Alexandria was the central point of his labours; and there he was martyred on a day when the heathen feast of Serapis was being observed, and which also appears to have been Easter Day, probably April 25th, and perhaps late in the first century, after most of the Apostles had gone to their rest. He was dragged from his place at the altar through the streets of the city, and over the rough cliffs adjoining, to prison; from whence the next morning he was again tortured in the same manner until his soul departed to spend a second and glorious Easter with his risen and ascended Lord.

One of the ancient Apostolic Liturgies goes by the name of St. Mark; and his Festival was formerly the day on which the Greater Litanies or Processions were said: but these latter originated with St. Gregory in the sixth century. [See Introduction to Litany, p. 47.]

It will be observed that the English Epistle and Gospel for this day were anciently, as they still are, different from those of the Latin and Oriental Churches.

SAINT PHILIP AND SAINT JAMES' DAY.

The Collect.

[A. D. 1549.]
Job xxii. 21.
Wisd. xv. 3.
John xvii. 3.
xiv. 6—9.
1 John v. 20.
Acts xv. 6. 13.
ii. 42.
Matt. vii. 14.

O ALMIGHTY God, whom truly to know is everlasting life; Grant us perfectly to know thy Son Jesus Christ to be the way, the truth, and the life; that, following the steps of thy holy Apostles, Saint Philip and Saint James, we may stedfastly walk in the way that leadeth to eternal life, through the same thy Son Jesus Christ our Lord. *Amen.*

DIES APOSTOLORUM PHILIPPI ET JACOBI.

Salisbury Use.

	<i>Modern English.</i>	<i>Salisbury Use.</i>	<i>Modern Roman.</i>	<i>Eastern.</i>
EPISTLE.	James i. 1—12.	Wisd. v. 1—5.	Wisd. v. 1—5.	Acts viii. 26—39.
GOSPEL.	John xiv. 1—14.	John xiv. 1—13.	John xiv. 1—13.	John i. 44—51.

SAINT BARNABAS THE APOSTLE.

The Collect.

[A. D. 1549.]
Rev. iv. 8.
Acts xi. 22—24.
Heb. ii. 4.
Eph. iv. 8, 9.

O LORD God Almighty, who didst endue thy holy Apostle Barnabas with singular gifts of the Holy Ghost;

SANCTUS BARNABAS APOSTOLUS.

Salisbury Use.

INTROIT.—Hide me, O God, from the gathering together of the froward, and from the insurrection of wicked doers. Alleluia. Alleluia. Ps. Hear my voice, O God, in my prayer; preserve my life from fear of the enemy. Glory be.

SAINT PHILIP AND SAINT JAMES.

[MAY 1.]

In the Lectionary of St. Jerome and the Sacramentary of St. Gregory the names of these two Apostles are associated together as they are in the Latin and English Churches of modern times: and the day of the Festival is in both cases the same as that now observed. But in the Eastern Church St. Philip's day is November 14th, and St. James' day October 23rd. It will also be observed that the Apostle St. Philip alone is named for May 1st in the ancient Calendar of the Venerable Bede, printed in a previous page; and in some early Calendars of the English Church, June 22nd is dedicated to "Jacobus Alfei."

The Epistle for the day in the Eastern Church is the same portion of Scripture that was read for the Second Morning Lesson in our own Church until 1661: but it seems clear that the Philip there mentioned is Philip the Deacon, since St. Peter and St. John were sent to Samaria to confirm those whom he had baptized, which would not have been necessary in the case of an Apostle. It is curious to observe that the same error should have occurred in both the Eastern and the English Church; but there seems to have been much confusion among the ancients between St. Philip the Apostle and Philip the Deacon and Evangelist, arising out of a generally received opinion that the former was married [Euseb. v. 24], while it is recorded of the latter in Acts xxi. 9 that he had "four daughters, virgins, which did prophesy."

St. Philip was one of the first of our Lord's disciples, and is thought to have accompanied Him for some time while St. Andrew and St. Peter had returned to their occupation of fishing after their first call. It may have been this faithful companionship which led to the loving rebuke of our Lord recorded in the Gospel of the day, "Have I been so long time with you, and yet hast thou not known Me, Philip?" For the Apostle's zeal in bringing Nathanael and the Greeks to his Master appears to indicate a trained faith in the Person of the holy Jesus, as does even his aspiration, "Show us the Father, and it sufficeth us!"

In the account of the miracle of the loaves and fishes St. Philip also seems to have been specially under the loving eye of his Master, who sought to "prove him" before He tried the faith of the others. After the dispersion of the Apostles, St. Philip carried Christ and the Church to Northern Asia, and his name has also been connected with the early Church of Russia. St. Chrysostom and Eusebius both record that he was crucified and stoned on the cross, at Hierapolis, a great stronghold of idolatry, in Phrygia; and the tradition of the Church is, that his martyrdom took place immediately after he had procured by his prayers the death of a great serpent which was worshipped by the people of the city.

St. James the Less was son of Alphæus, or Cleophas, and of Mary, and nephew to Joseph the husband of the Blessed Virgin. Hence he was, in the genealogical phraseology of the Jews, a "brother of our Lord," as is shown in the table at page 79. It was also thought by the ancients that his mother Mary was cousin, or as the Hebrews would say "sister," to the Blessed Virgin Mary, and this would establish a double legal affinity between James and Jesus, her sons, and the holy Jesus. St. James the Less is mentioned by Josephus and in the Talmud, being well known to the Jews from his position as Apostle of the Church of Jerusalem up to the beginning of its last troubles: and having won even from them the name of "the just," a name shadowing that of his Master, so often called "the Righteous" in the Psalms. It is he whose name is several times mentioned by St. Paul; and he was the writer of the Catholic Epistle of St. James. He went to his rest by martyrdom [A. D. 62], in Jerusalem, being thrown down from a pinnacle or wing of the Temple by some of the persecuting Scribes and Pharisees, and slain, as he lay bruised on the ground below, with a fuller's club.

The only reason that can be suggested for coupling together St. Philip and St. James is, that by thus doing the manner in which our Lord sent forth His Apostles two and two is illustrated. St. Simon and St. Jude, St. Peter and St. Paul, St. Barnabas and St. Bartholomew are parallel instances.

INTROIT.—They cried unto Thee in the time of their trouble, and Thou heardest them from Heaven. Alleluia. Alleluia. Ps. Rejoice in the Lord, O ye righteous, for it becometh well the just to be thankful. Glory be.

Rom. xii. 6—8.
1 Tim. i. 17.

Leave us not, we beseech thee, destitute of thy manifold gifts, nor yet of grace to use them alway to thy honour and glory; through Jesus Christ our Lord. *Amen.*

	<i>Modern English.</i>	<i>Salisbury Use.</i>	<i>Modern Roman.</i>	<i>Eastern.</i>
EPISTLE.	Acts xi. 22—30.	Eph. ii. 19—22.	Acts xi. 21—xiii. 3.	[with St. Bartholomew.] Acts xi. 19—30.
GOSPEL.	John xv. 12—16.	John xv. 12—16.	Matt. x. 16—22.	Luke x. 16—21.

SAINT JOHN BAPTIST.

The Collect.

[A.D. 1549.]

Mal. iv.
Luke i.
Matt. iii. 1—8.
xi. 11—14.
John i. 6, 7, 29.
x. 47, v. 33.
Matt. xiv. 3, 4.
6, 8, 10.
1 Pet. iv. 19.

ALMIGHTY God, by whose providence thy servant John Baptist was wonderfully born, and sent to prepare the way of thy Son our Saviour, by preaching of repentance; Make us so to follow his doctrine and holy life,

DIES SANCTI JOHANNIS BAPTISTÆ. *Salisbury Use.*

SAINT BARNABAS.

[JUNE 11.]

This festival is not of primitive antiquity, being unnoticed in the ancient Lectionaries and Sacramentaries. In the Calendar of the Venerable Bede it is the 10th instead of the 11th of June; and in the Eastern Church the name of St. Barnabas is associated with that of St. Bartholomew, the latter being also commemorated on August 25th. The day was omitted from the English Calendar of 1552, but the Service was retained. In Fothergill's MS. it is stated that the day was not observed because St. Barnabas was not one of the twelve¹.

The name of St. Barnabas derives its chief lustre from his association with St. Paul; yet, independently of this, he was one worthy to be ranked among the saints of the Church as an Evangelist, Apostle, and Martyr.

The Apostle St. Barnabas was born at Cyprus, but was a Jew of the tribe of Levi, and his original name was Joses or Joseph. Some of the Fathers record that he was one of the seventy disciples, and that he was brought up with St. Paul at the feet of Gamaliel. After our Lord's Ascension he received the name of Barnabas, or "Son of Consolation," from the Apostles; and showed his zeal for Christ by selling his property that the Apostles might distribute the proceeds among the poor; an act which possibly originated the name by which he has ever since been known. St. Chrysostom hands down a tradition that he was a man of very amiable disposition but commanding aspect. Having brought St. Paul to the Apostles he was associated with him for about fourteen years, and on several missionary journeys. After their separation nothing further is recorded of St. Barnabas in Holy Scripture; but the traditions of the Church represent that he spent the remainder of his life among his fellow-countrymen at Cyprus, and that he was stoned by the Jews at Salamis under circumstances somewhat similar to those which brought St. Stephen to his death. What was supposed to be the body of St. Barnabas was discovered four centuries after his martyrdom, a Hebrew copy of St. Matthew's Gospel lying next his heart, which was believed to have been

¹ Hence we find Bishop Wren in 1636 giving direction that "ministers forget not to read the collects, epistles, and gospels appointed for the Conversion of St. Paul . . . and for St. Barnaby's Day." *Card. Dec. Ann. II. 202.*

written by himself. An Epistle is extant, bearing the name of St. Barnabas, which is considered by many scholars to be authentic.

The Gospel for the day is evidently selected with reference to the act of St. Barnabas in consoling the poor disciples in their poverty. He acted upon the command of our Lord in the spirit with which the example of the Good Samaritan is commended to us, and showed his love by going and doing likewise.

INTROIT.—Thy friends are exceeding honourable unto me, O God: greatly is their beginning strengthened. Ps. O Lord, Thou hast searched me out and known me: Thou knowest my downsitting and mine uprising. Glory be.

SAINT JOHN THE BAPTIST.

[JUNE 24.]

This festival is in the Comes of St. Jerome, as also another commemorating the Beheading of St. John the Baptist, but the date is not indicated in either case. Mabillon says that the festival of this day was in the Carthaginian Calendar before A.D. 484; and it is mentioned [circ. A.D. 400] by Maximus, Bp. of Turin, as also by St. Augustine, in several Homilies. In the Eastern Church it is kept on January 7th, the day after the holy Theophany; and the festival of the Decollation is also fixed, as in the Latin Church and our own, for August 29th. The day on which our principal Festival of St. John the Baptist is kept has been supposed to be connected with his words, "He must increase, but I must decrease;" the days of the Bridegroom are growing longer, but those of the friend of the Bridegroom are beginning to wane. So St. Augustine says [Hom. 287], "John was born to-day, and from to-day the days decrease; Christ was born on the eighth of the kalends of January, and from that day the days increase." But the 24th of June is also the proximate day of the Baptist's birth, since he was six months older than our Lord.

Although the martyrdom of St. John Baptist is one of the four recorded in Holy Scripture (the other three being those of the Holy Innocents, St. Stephen, and St. James), yet the present festival, which commemorates his Nativity, appears to be the more ancient of the two dedicated to his name, and the one more generally observed. So we may judge from the Sermons both of Maximus and St. Augustine, each of whom accounts for the custom of observing the Birth and not the Martyrdom of the

that we may truly repent according to his preaching ; and after his example constantly speak the truth, boldly rebuke vice, and patiently suffer for the truth's sake ; through Jesus Christ our Lord. *Amen.*

	<i>Modern English.</i>	<i>Salisbury Use.</i>	<i>Modern Roman.</i>	<i>Eastern.</i>
EPISTLE.	Isa. xl. 1—11.	Isa. xlix. 1—3.	Isa. xlix. 1—7.	Rom. xiii. 11. xiv. 1—4.
GOSPEL.	Luke i. 57—80.	Luke i. 57—68.	Luke i. 57—68.	Luke i. 24, 25. 57—68.

SAINT PETER'S DAY.

The Collect.

[A.D. 1549.]
2 Pet. i. 1. 3.
Acts iii. 6.
Matt. xvi. 18, 19.
John xxi. 15—17.
Acts xx. 28.
Heb. xiii. 7, 17.
1 Pet. v. 2—4.

O ALMIGHTY God, who by thy Son Jesus Christ didst give to thy Apostle Saint Peter many excellent gifts, and commandedst him

DIES APOSTOLORUM PETRI ET PAULI. *Salisbury Use.*

Precursor of our Lord as if no other festival in his honour had yet been established. "The prophets who had gone before were first born, and at a later day prophesied, but St. John Baptist heralded the Incarnation of our Lord when His Virgin Mother came to visit Elizabeth, and both the Precursor and the Holy Child were yet unborn."

The miraculous birth of St. John the Baptist, and all that we know of his subsequent history, is told us in the opening chapters of the four Gospels, in the 11th of St. Matthew, and the 9th of St. Luke. By comparing our Lord's words in Matt. xi. 14, those of the angel in Luke i. 16, 17, of Zacharias in Luke ii. 76, and those of St. John himself in announcing his mission, with preceding prophecies, we see that the prophets had spoken of him more than seven hundred years before he was born, and that the very last words of the Old Testament, written about four hundred years previously, were concerning him. And, comparatively little as is said about St. John in Holy Scripture, what is said shows how important his office was, and illustrates the words of our Lord, that among all previously born of women, none was ever greater than John the Baptist.

He appears to have spent his childhood, at least, with our Blessed Lord and His mother, and it is natural to suppose that his parents lived but a few years after his birth. But when the time for his ministry came, he adopted the ancient prophetic mode of life ; such as is indicated in the case of Elijah the Tishbite, who is said [2 Kings i. 8] to have been "an hairy man, and girt with a girdle of leather about his loins." As a prophet, and the greatest of all,—the last prophet of the old dispensation, and the first of the new,—he assailed the vices of the generation in which our Lord came, as Elijah himself had assailed those of Ahab and the Israel of that day ; and so doing he brought many to repentance, and initiated a new moral life by that ordinance of Baptism with which the dispensation of Sinai ended, and that of Calvary began. And when by the power of his preaching he had prepared the hearts of the people to receive Christ as a blessing, and not as one "come to smite the earth with a curse" [Mal. iv. 6], the other part of his office was brought into exercise, that of baptizing our Lord, and witnessing to the descent of the Holy Spirit on His human nature.

Powerful as the effect of St. John the Baptist's ministrations evidently was, we have very little information given us about it. He proclaimed the coming of Christ, rebuked all classes of the people for their sins, showed them the way to turn from them, and baptized with a Baptism of water which foreshadowed the Baptism with the Holy Ghost as well as water. All people seem

to have come readily to him, for the "offence of the Cross" had not yet begun, and the prophet who attracted was no "carpenter's son," but "a prophet indeed," the son of a man well known among them, a priest of the regular succession of Aaron, prophesying as Elijah, Isaiah, or Ezekiel, with the outward appearance and habit of a "man sent from God," and telling of that which they longed for, the near approach of their Messiah. This is all we learn of the ministry of the Baptist from Holy Scripture, and tradition has added little or nothing more. His martyrdom appears to have taken place very early in our Lord's ministry, and when St. John himself was only about thirty years of age ; and since his work was done, we may see in it the manner in which the course of even the evil of this world is so regulated, that it ministered by a quick death to the rapid removal of a saint from the Church on earth to the Church in Heaven when the time of his reward was come.

INTROIT.—The Lord hath called me by name from the womb of my mother. He hath made my mouth like a sharp sword. In the shadow of His hand hath He hid me : He hath made me like a polished shaft, and in His quiver hath He concealed me. Ps. It is a good thing to give thanks unto the Lord, and to praise Thy Name, O Thou most highest. Glory be.

SAINT PETER.

[JUNE 29.]

This day is one of the oldest of Christian festivals, and one that was from the beginning of its institution celebrated with great solemnity. Ruinart [617] traces it back as far as the third century, and it is probably of even more primitive antiquity. In St. Jerome's Lectionary there are two Gospels and two Epistles, the one pair under the name of St. Peter, the other under that of St. Paul. As there is only one Vigil, and one Octave, which is called the Octave of the *Apostles*, the day was evidently then dedicated to both Apostles, as it was in the English Church until the Reformation [a "Commemoration" of St. Paul following on the 30th], and as it still is in the Latin and the Eastern Church. It was a very early custom for the Bishops of Rome to celebrate the Holy Communion in both St. Peter's and St. Paul's Churches on this day, a custom which is mentioned [A.D. 348] by Prudentius [Peristephano, carm. xii.],

Transtyberina prius solvit sacra pervigil sacerdos,
Mox huc recurrit, duplicatque vota.

earnestly to feed thy flock; Make, we beseech thee, all Bishops and Pastors diligently to preach thy holy Word, and the people obediently to follow the same, that they may receive the crown of everlasting glory; through Jesus Christ our Lord. *Amen.*

	<i>Modern English.</i>	<i>Salisbury Use.</i>	<i>Modern Roman.</i>	<i>Eastern.</i>
EPISTLE.	Acts xii. 1—11.	Acts xii. 1—11.	Acts xii. 1—11.	2 Cor. xi. 21—xii. 9.
GOSPEL.	Matt. xvi. 13—19.	Matt. xvi. 13—19.	Matt. xvi. 13—19.	Matt. xvi. 13—19.

SAINT JAMES THE APOSTLE.

The Collect.

1549.]
Matt. iv. 21 22.
xix. 27—29.
Acts xii. 1, 2.
John xiv. 21.
Rev. xxii. 14.

GRANT, O merciful God, that as thine holy Apostle Saint James, leaving his father and all that he had,

DIES SANCTI JACOBI APOSTOLI.

Salisbury Use.

He also speaks of the whole city frequenting each church, as if the festival was kept very generally and with great solemnity. St. Augustine, St. Leo, and several others of the Fathers have left sermons preached on the day of St. Peter and St. Paul; and no doubt the two, from their relative positions as the chief Apostles of the Jews and the Gentiles, from their joint ministrations at Rome, and from their martyrdom together there on the same day, have always had this day dedicated in their united names. Bishop Cosin restored the title "Saint Peter's and Saint Paul's Day" in his Durham Prayer Book, and added to the Collect, so that it should read ". . . commandedst him earnestly to feed Thy flock, and madest Thy Apostle St. Paul a choice vessel to bear Thy name before the Gentiles, make, we beseech Thee, all Bishops and all other ministers of Thy Church, diligently to preach Thy holy Word . . ." He also altered the Epistle to 2 Tim. iv. 1—9; but none of these changes were adopted.

St. Peter was one of the first-called of our Lord's disciples [John i. 35—42], and as soon as he had come to follow Christ, he was marked out by a new name, that of Cephas, the Syriac equivalent of the one by which he has since been so familiarly known to the Church. Our Lord did nothing without a meaning, and in giving this new name to His disciple, He appears to have prophetically indicated the strong, immovable faith in Him which that disciple was to exhibit; and the firmness of which is not contradicted even by that temporary want of courage which led him to try and save his life by denial of his Master in the bitter hour of His Passion. Such instances of faith as St. Peter's attempt to walk on the water, and his confession of Christ as the Son of the living God, seem to set him at the head of the Apostles, as one whom no shock could move from his belief in the Lord; and the striking words of our Lord which are recited in the Gospel for this day show that a special revelation had been vouchsafed to the Apostle to give him that knowledge of Christ on which his faith rested. It was, perhaps, because St. Peter's faith was stronger than that of the other Apostles that he had to undergo greater temptation. Satan desired to "sift him as wheat," as he had desired to tempt Job; but one look from Jesus brought him to himself and counteracted the temptation. A similar temptation is said to have assailed him just before his martyrdom, as our Lord's agony was a kind of second temptation. St. Peter too desired that the cup might pass from him, and endeavoured to escape from Rome. But as he was leaving the city he had such a vision of his Master as St. Paul had on his way to Damascus. "Lord, whither goest Thou?" were the

words of the Apostle, and the reply was a question whether that Master must go to Rome and again suffer, since His servants were afraid to die for His sake. As when Jesus had "looked on" the Apostle years before in the hall of Pilate, so now, the trial of faith ended in a victory, and the servant returned to follow the Master by being girded by another than himself, and led whither he would not at the first have gone, to the Cross. At his own request he was crucified with his head downwards to make the death more ignominious and painful; and as being unworthy to suffer the same death as his Lord. This was in the year 63; and while St. Peter was being crucified at the Vatican, St. Paul was being beheaded at *Aqua Salvæ*, three miles from Rome.

Our Lord's remarkable words, "I will give unto thee the keys of the kingdom of heaven," do not seem to be wholly explained by saying that St. Peter represented all the Apostles, and that these words represented the power given to all. But if they implied any distinction of authority between St. Peter and his brethren, they do not give any foundation whatever to the claims which the Bishops of Rome have made as successors of St. Peter: for (1) there is no evidence that they are in any special sense successors of St. Peter, and (2) if our Lord's words cannot clearly be applied to the other Apostles, much less can they be applied to Bishops of later days who were not Apostles. There is nothing in the Scriptural account of St. Peter's Apostolic work which adequately explains these words; nor does the tradition of the Church respecting that work show any thing that at all helps to do so. He presided over the Church at Antioch for some time,—a fact commemorated by the festival of St. Peter's Chair at Antioch,—assisted, as it appears, in evangelizing Chaldaea, and was probably some years at Rome before his death. During these years it seems most likely that he was all the while acting chiefly as the Apostle of the Circumcision, having charge of Jewish Christians: and, while great works were undoubtedly assigned to the other Apostles, there are evident traces of a providential disposition of duties by which Jewish Christianity became the field of St. Peter's labours; Gentile Christianity that of St. Paul's (the successor of St. James); and the general government of the Church, when Jewish and Gentile Christianity were merging into one, the work of St. John, when the others had passed away from their labours.

INTROIT.—Now I know of a surety that the Lord hath sent His angel, and hath delivered me out of the hand of Herod, and from all the expectation of the Jews. Ps. And when Peter was come to himself he said. Glory be.

without delay was obedient unto the calling of thy Son Jesus Christ, and followed him; so we, forsaking all worldly and carnal affections, may be evermore ready to follow thy holy commandments; through Jesus Christ our Lord. *Amen.*

	<i>Modern English.</i>	<i>Salisbury Use.</i>	<i>Modern Roman.</i>	<i>Eastern.</i>
EPISTLE:	Acts xi. 27. xii. 3.	Eph. ii. 19—22.	1 Cor. iv. 9—15.	Acts xii. 1—11.
GOSPEL.	Matt. xx. 20—23.	Matt. xx. 20—23.	Matt. xx. 20—23.	Luke ix. 1—6.

SAINT BARTHOLOMEW THE APOSTLE.

The Collect.

John i. 45—51.
xxi. 2.
Matt. x. 2—5.
1 Thess. ii. 13.
Eph. iii. 8—10.
20, 21.

O ALMIGHTY and everlasting God, who didst give to thine Apostle Bartholomew grace truly to believe and to preach thy Word; Grant,

IN DIE S. BARTHOLOMÆI APOSTOLI.

Oratio.

OMNIPOTENS sempiternæ Deûs, qui hujus diei venerandam sanctamque lætitiã in beati Bartholomæi Apostoli tui festivitãte tribuisti; Da

Salisbury Use.
Greg. Nat. S.
Barth. Ap.

SAINT JAMES THE GREAT.

[JULY 25.]

The festival of St. James, the brother of St. John the Divine, is not noticed in the Lectionary of St. Jerome, but has a Collect appointed in St. Gregory's Sacramentary, and is also in the ancient English Calendars of Bede and of King Athelstan's Psalter. In the Eastern Church it is kept on April 30th, but in the Western it has always been observed on July 25th.

St. James being a brother of the beloved disciple, his relationship to our Lord may be seen in the table printed under that Apostle's day [p. 79]. With St. John he received the appellation of Boanerges from our Lord, and has always been surnamed the Great, or the Greater, by the Church: but neither of these designations can be satisfactorily accounted for. Some special position was given to St. James and St. John, as well as to St. Peter, by their Divine Master; and the request of their mother, probably Salome, that they might sit on either hand of our Lord in His Kingdom, was doubtless founded on the choice thus made by Him, coupled with such a strong faith in His Person and Power as was displayed on another occasion, when the sons of Zebedee sought authority from Christ to destroy the Samaritan city that had rejected Him. [Luke ix. 52.] Their Master told His servants that they should eat and drink at His table in His Kingdom, and sit on thrones judging the twelve tribes of Israel; and since He had given to St. Peter the Keys of the Kingdom of Heaven, the other two favoured Apostles besought that to them might be given the two posts of honour and suffering next to His Person.

St. James was the first of the Apostles who suffered Martyrdom, and the only one whose death is recorded in the New Testament. The fact of his death is told us in the modern English Epistle of the day, but of its circumstances nothing more is known than that he suffered through the hatred of Herod Agrippa. Tradition says that his accuser repented as the Apostle was on his way to the place of execution, and that having received the blessing of the servant of Christ, he professed himself a Christian, and was baptized in the blood of martyrdom at the same time with St. James. The Apostolic mantle of St. James appears to have fallen upon St. Paul, and perhaps we may look upon the latter as fulfilling the expectations which must have been raised by the place which the elder son of Zebedee occupied near the Person of our Lord, and by the title of Boanerges which was given to him.

St. James the Great is the patron saint of Spain, and his remains are supposed to be preserved at Compostella. "St. Iago of Compostella" holds the same relation to the history of that kingdom which St. George does to that of England: and both names have been used as the battle-cry of Christian hosts when they went forth to stem the torrent of that Mahometan and Moorish invasion which once threatened to drive Christianity from its throne in Europe as it has driven it from Asia.

INTROIT.—Thy friends are exceeding honourable unto me, O God: greatly is their beginning strengthened. Ps. O Lord, Thou hast searched me out and known me: Thou knowest my down-sitting and mine uprising. Glory be.

SAINT BARTHOLOMEW.

[AUGUST 24.]

There is no festival of St. Bartholomew in the Lectionary of St. Jerome, but it appears in the Sacramentary of St. Gregory. In the Eastern Church this Apostle is commemorated on the same day with St. Barnabas, as St. Simon and St. Jude are connected in the Western Church; but on this day there is also a commemoration of the Translation of St. Bartholomew. There is absolutely nothing but his name recorded of St. Bartholomew in the New Testament (though it has usually been supposed that Nathanael and Bartholomew are two names for the same person); but the Gospel of the day perpetuates an old tradition that St. Bartholomew was of noble birth, and that hence arose the "strife" among the Apostles, "which of them should be accounted the greatest" in their Master's expected kingdom.

The reasons why Nathanael and Bartholomew are supposed to be the same person are as follows. (1) The call of St. Bartholomew is nowhere mentioned, while that of Nathanael appears to be the call of an Apostle. (2) The Evangelists who mention Bartholomew do not name Nathanael, while St. John, who tells us of the latter, does not name Bartholomew. (3) Bar-Tholmai may be only an appellation of Nathanael, as Bar-Jona is of St. Peter; since it signifies 'the son of Tholmai,' as the latter does 'the son of Jonas,' and as Barnabas means 'the son of consolation.' But strong as these reasons seem, there is the strong testimony of the Fathers against them. St. Augustine, St. Chrysostom, St. Gregory Nyssen, and St. Gregory the Great, all declare that Nathanael was not one of the twelve: and the

we beseech thee, unto thy Church, to love that word which he believed, and both to preach and receive the same; through Jesus Christ our Lord. *Amen.*

Ecclesiae tuae, quæsumus, et amare quod credidit, et prædicare quod docuit. Per Dominum nostrum.

	<i>Modern English.</i>	<i>Salisbury Use.</i>	<i>Modern Roman.</i>	<i>Eastern.</i>
EPISTLE.	Acts v. 12—16.	Eph. ii. 19—22.	1 Cor. xii. 27—31.	[See St. Barnabas' Day.]
GOSPEL.	Luke xxii. 24—30.	Luke xxii. 24—30.	Luke vi. 12—19.	

SAINT MATTHEW THE APOSTLE.

The Collect.

[A.D. 1549.]
Matt. ix. 9.
Luke xii. 15.
xviii. 22—24.
28—30.
Matt. xvi. 24—
26.
John xii. 26.

O ALMIGHTY God, who by thy blessed Son didst call Matthew from the receipt of custom to be an Apostle and Evangelist; Grant us grace to forsake all covetous desires and inordinate love of riches, and to follow the same thy Son Jesus Christ, who liveth and reigneth with thee and the Holy Ghost, one God, world without end. *Amen.*

DIES SANCTI MATTHEI APOSTOLI. *Salisbury Use.*

	<i>Modern English.</i>	<i>Salisbury Use.</i>	<i>Modern Roman.</i>	<i>Eastern.</i>
EPISTLE.	2 Cor. iv. 1—6.	Ezek. i. 10—14.	Ezek. i. 10—14.	1 Cor. iv. 9—16.
GOSPEL.	Matt. ix. 9—13.	Matt. ix. 9—13.	Matt. ix. 9—13.	Matt. ix. 9—13.

opinion that he was identical with Bartholomew is first found in a Benedictine author named Rupert, who wrote in the twelfth century. St. Augustine uses the fact that Nathanael was not an Apostle as a proof of his great holiness and ready perception of Christ:—"This was not said to Andrew, nor said to Peter, nor to Philip, which is said to Nathanael, 'Behold an Israelite indeed, in whom is no guile:'"—and assigns his learning and position in life as a reason why He Who chose the weak things of the world to confound the strong did not make him an Apostle.

The common tradition of the Church respecting St. Bartholomew is that he evangelized Northern India, leaving there a Hebrew copy of St. Matthew's Gospel, which afterwards came into the hands of Pantænus, head of the college of Alexandria, about A.D. 190. It is believed that, having once escaped crucifixion at Hierapolis in Phrygia, through the remorse of his persecutor, St. Bartholomew was afterwards martyred at Albanopolis on the Caspian Sea, where the king Astyages ordered him to be flayed alive (perhaps on the cross), a mode of punishment not uncommon among Oriental nations.

INTROIT.—Thy friends are exceeding honourable unto me, O God: greatly is their beginning strengthened. Ps. O Lord, Thou knowest my downsitteing and mine uprising. Glory be.

SAINT MATTHEW.

[SEPTEMBER 21.]

The festival of this Apostle has Gospel and Epistle appointed for it in the Comes of St. Jerome, but it does not seem to have been celebrated in September; and in the Oriental Church it is still observed on November 16th. In his double capacity of Apostle and Evangelist, the first who was inspired to write the Holy Gospel, and who tells us more than all of our Lord's human

life, his name has ever been much honoured in the Church. Of the four "living creatures" by whom the Apocalypse is believed to symbolize the Evangelists or their Gospels, the "likeness of a man" is the one assigned to St. Matthew, as significant of the prominence which his Gospel gives to our Lord's human nature.

This holy Apostle and Evangelist is first mentioned in his own Gospel and by the other Evangelists as a Roman toll-gatherer, though he himself was a Jew. His office was to collect tolls and customs from those who passed over the sea of Galilee, and it appears to have been near Capernaum that he was engaged in this duty when he heard the words of Jesus, "Follow Me" [Matt. ix. 9]. As the sons of Zebedee had left their ships, their nets, and their occupation, to obey those words, so did St. Matthew give up his profitable employment to do the bidding of Him who had "not where to lay His head:" and, as it seems to have been immediately afterwards that our Lord made him one of His Apostles, the forsaking of all that he had must have been as final as it was sudden, showing how entirely obedient he became to his Lord. After the dispersion of the Apostles St. Matthew took part in the evangelization of Chaldæa, and gave up his life to his Master's service by martyrdom at Nadabar. His Gospel is supposed to have been written by him originally in Hebrew for the Jewish Christians, but the Hebrew version appears to have been soon superseded by one in Greek, which was doubtless the work of the Evangelist himself, for it has always been received into the Canon of Holy Scripture. A copy of the Hebrew text is said to have been found in the grave of St. Barnabas A.D. 485, but it is not now extant.

INTROIT.—Thy friends are exceeding honourable unto me, O God: greatly is their beginning strengthened. Ps. O Lord, Thou hast searched me out and known me: Thou knowest my downsitteing and mine uprising.

SAINT MICHAEL AND ALL ANGELS.

The Collect.

Col. i. 16.
Ps. lxxviii. 17.
civ. 4.
Rev. vii. 11.
Isa. vi. 1-3.
Rev. iv. 8.
Ps. xxxiv. 7.
Heb. i. 14.

O EVERLASTING God, who hast ordained and constituted the services of Angels and men in a wonderful order; Mercifully grant, that as thy holy Angels alway do thee service in heaven, so by thy appointment they may succour and defend us on earth; through Jesus Christ our Lord. *Amen.*

IN FESTO SANCTI MICHAELIS ARCH-
ANGELI,

Oratio.

DEUS, qui miro ordine Angelorum ministeria hominumque dispensas; concede propitius, ut quibus tibi ministrantibus in cœlo semper assistitur, ab his in terra vita nostra muniantur. Per Dominum.

Salisbury Use.
Greg. Dedicatio
Basilicæ S.
Arch. Michaelis.

[**G**OD, that in a merueilous ordre ordeynedist seruysys of aungels and of men, graunte thou mercifulli that oure lijf be defendid in erthe bi hem that stonden nyȝ euermore seruyng to thee in heuvene. Bi crist.]

XIVth Century
Primer version.

	<i>Modern English.</i>	<i>Salisbury Use.</i>	<i>Modern Roman.</i>	<i>Eastern.</i>
EPISTLE.	Rev. xii. 7-12.	Rev. i. 1-5.	Rev. i. 1-5.	Heb. ii. 2-10.
GOSPEL.	Matt. xviii. 1-10.	Matt. xviii. 1-10.	Matt. xviii. 1-10.	Luke x. 16-21.

MICHAELMAS DAY.

[SEPTEMBER 29.]

There were anciently two days dedicated to St. Michael, May 8th and September 29th: and in mediæval times a third, to St. Michael *in monte tumba*¹, on October 16th. But the day most generally observed was that which we now keep, and which appears both in the Lectionary of St. Jerome and in the Sacramentary of St. Gregory, as the Dedication of the Church of St. Michael. This basilica may have been that of Constantine near Constantinople, or that of Boniface at Rome, the latter being dedicated A.D. 606. In the Eastern Church St. Michael's day is November 8th, July 13th and March 26th being also observed in honour of the Archangel Gabriel. These two are the only angels or archangels who are made known to us by name in the Canonical Scriptures, though Raphael and Uriel are named in the book of Tobit and in Esdras.

The holy angels in general are commemorated by the Church from a deeply rooted feeling of their communion with the saints, and of their ministrations among mankind on earth. Such a feeling is warranted by the words, "Ye are come unto Mount Sion, and unto the city of the living God, the heavenly Jerusalem, and to an innumerable company of angels; to the general assembly and Church of the Firstborn . . ." [Heb. xii. 22]: and, "are they not all ministering spirits, sent forth to minister for them who shall be heirs of salvation?" [Heb. i. 14.] The holy Son of God condescended to be ministered to by angels in His Temptation and Agony; they waited upon Him at His Birth and Resurrection; and at His Second Advent He will come with "all the holy angels." St. Peter was set free from prison by an angel, and one stood by St. Paul in the ship, thus illustrating their ministration to Christ's servants. Our Lord Himself spoke of their rejoicing over penitent sinners; and said of the little ones who had passed under His hand and benediction, that "their

angels do always behold the face of My Father which is in heaven," as if indicating many ministrations to those who are His,—some known, and some that are not made evident to sight or other sense. It has been a constant tradition of Christianity that angels attend at the ministration of Holy Baptism, and at the celebration of the Holy Communion; and that as Lazarus was the object of their tender care, so in sickness and death they are about the bed of the faithful, and carry their souls to the presence of Christ in Paradise.

Without taking into account, therefore, any of the many unveilings to our sight of holy angels and their ministrations recorded in the Old Testament, we have ample ground for believing that they are joined in a very close communion with those who have been redeemed by the blood of Christ. But whereas the saints were once sinners, and yet God is pleased that we should honour Him through them, the angels have never inherited unholiness or fallen from holiness, and still more shall we honour Him by venerating these pure and spotless servants of His who do His pleasure. And as our Lord has taught us to pray that we may do the will of our Father on earth as it is done in heaven, so may we take their example as the highest, next to His, of perfect submission to the will of God. While in respect to our worship on earth we may reckon it an exalted privilege to have such communion with them as to be able to say, "Therefore with angels and archangels, and all the company of Heaven, we laud and magnify Thy glorious Name, evermore praising Thee, and saying, Holy, Holy, Holy, Lord God of hosts, heaven and earth are full of Thy glory: Glory be to Thee, O Lord most High."

INTROIT.—O praise the Lord, ye angels of His, ye that excel in strength: ye that fulfil His commandment, and hearken unto the voice of His words. Ps. Praise the Lord, O my soul: and all that is within me praise His holy Name.

HYMN.

MATTENS AND EVENSONG.—*Tibi Christe, Splendor Patris.*
H. N. 42. 94.

¹ Churches dedicated to St. Michael are often on elevated spots, as at St. Michael's Mounts in Normandy and Cornwall.

SAINT LUKE THE EVANGELIST.

The Collect.

[A.D. 1549.]
 Luke i. 1—3.
 x. 1.
 Col. iv. 14.
 2 Cor. viii. 18.
 Prov. xxiii. 1, 2.
 1 Tim. vi. 3, 4.
 Ps. ciii. 2, 3.

ALMIGHTY God, who calledst Luke the Physician, whose praise is in the Gospel, to be an Evangelist, and Physician of the soul; May it please thee, that, by the wholesome medicines of the doctrine delivered by him, all the diseases of our souls may be healed; through the merits of thy Son Jesus Christ our Lord. *Amen.*

SANCTUS LUCAS EVANGELISTA.

Salisbury Use.

	<i>Modern English.</i>	<i>Salisbury Use.</i>	<i>Modern Roman.</i>	<i>Eastern.</i>
EPISTLE.	2 Tim. iv. 5—15.	Ezek. i. 10—14.	2 Cor. viii. 16—24.	Col. iv. 5—13.
GOSPEL.	Luke x. 1—7.	Luke x. 1—7.	Luke x. 1—9.	Luke x. 16—21.

SAINT SIMON AND SAINT JUDE APOSTLES.

The Collect.

[A.D. 1549.]
 Eph. ii. 19—22.
 Rev. xxi. 14.
 Matt. xxi. 42.
 xvi. 18.
 Eph. iv. 3—6. 13.
 1 Cor. i. 10. iii. 16, 17.
 1 Pet. ii. 5.

OALMIGHTY God, who hast built thy Church upon the foundation of the Apostles and Prophets, Jesus Christ himself being the head corner-stone; Grant us so to be joined together in unity of spirit by their doctrine, that we may be made an holy temple acceptable unto thee; through Jesus Christ our Lord. *Amen.*

DIES APOSTOLORUM SIMONIS ET JUDE.

Salisbury Use.

	<i>Modern English.</i>	<i>Salisbury Use.</i>	<i>Modern Roman.</i>	<i>Eastern.</i>
EPISTLE.	Jude 1—8.	Rom. viii. 28—39.	Eph. iv. 7—13.	Jude.
GOSPEL.	John xv. 17—27.	John xv. 17—25.	John xv. 17—25.	John xiv. 21—24.

SAINT LUKE.

[OCTOBER 18.]

A festival was dedicated in honour of St. Luke, as of the other Evangelists, at a very early period of Christian history, and is found in an ancient Calendar [earlier than A.D. 484] of the Church of Carthage. St. Jerome says [De Script. Ecc.] that the remains of St. Luke were translated to Constantinople in the twentieth year of Constantine the Great, and there laid in the magnificent church which he had built in honour of the Apostles; but whether the present festival commemorates this event or not there is no evidence to show.

Little is indicated to us by Holy Scripture of St. Luke's personal history. His native place appears to have been Antioch, and as St. Paul calls him "the beloved physician" [Col. iv. 14], it seems clear that these words represent his profession. Yet ancient traditions have connected him with the art of painting, and several portraits exist which are attributed to him, showing how general this tradition is. The Evangelist was probably one of St. Paul's converts; for though there is a tradition that he was one of the seventy, the dedication of his Gospel seems to exclude himself from the number of those who had been eye-witnesses of our Lord's life and works. After the separation of St. Paul from St. Barnabas, the Evangelist constantly accompanied the former in his journeyings and missions; and the latter half of the Acts of the Apostles records not only what he heard

from others, but the events which had occurred within his own experience while sharing St. Paul's work and dangers. Hence St. Paul speaks of him in affectionate terms as his "fellow-labourer," "the beloved physician," and "the brother whose praise is in the Gospel throughout all the churches." He continued his missionary labours long after the death of St. Paul, and is believed to have reached his rest through martyrdom, being crucified upon an olive-tree at eighty years of age.

INTRAIT.—The mouth of the righteous is exercised in wisdom: and his tongue will be talking of judgment. The law of his God is in his heart. Ps. Fret not thyself because of the ungodly, neither be thou envious against the evil doers. Glory be.

SAINT SIMON AND SAINT JUDE.

[OCTOBER 28.]

The festival of St. Simon and St. Jude appears in the Lectionary of St. Jerome, but it is only in the Western Calendars that the two Apostles are commemorated on the same day. In the Eastern St. Simon Zelotes' festival is May 10th, and St. Jude's June 19th. They appear to have been sons of Cleophas, or Alphæus, and nephews of Joseph, and hence they are called brethren of our Lord,—the word brethren being taken in a wider sense among the Jews than with us.

Of St. Simon we have no notice in Holy Scripture beyond the fact that he was surnamed in Hebrew the Cananite, or in Greek

ALL SAINTS' DAY.

DIES OMNIUM SANCTORUM.

Salisbury Use.

The Collect.

[A.D. 1549.]
1 John i. 3.
John xvii. 20, 21.
Eph. ii. 19. v. 30.
32.
Col. ii. 2. 19.
Heb. vi. 12.
Phil. iv. 8, 9.
1 Cor. ii. 9.
Heb. xii. 22-24.

O ALMIGHTY God, who hast knit together thine elect in one communion and fellowship, in the mystical body of thy Son Christ our Lord; Grant us grace so to follow thy blessed Saints in all virtuous and godly living, that we may come to those unspeakable joys, which thou hast prepared for them that unfeignedly love thee; through Jesus Christ our Lord.

Amen.

	<i>Modern English.</i>	<i>Salisbury Use.</i>	<i>Modern Roman.</i>	<i>Eastern.</i>
EPISTLE.	Rev. vii. 2-12.	Rev. vii. 2-12.	Rev. vii. 2-12.	Heb. xi. 33. xii. 1.
GOSPEL.	Matt. v. 1-12.	Matt. v. 1-12.	Matt. v. 1-12.	Matt. x. 32, 33, 37, 38. xix. 27-30.

Zelotes, both words signifying a zealot; but in what sense is not apparent, unless the appellation is given him because he was one of a strict sect of Pharisees.

St. Jude, Judas, Thaddæus, or Lebbaeus, calls himself "the brother of James," apparently to distinguish himself from Judas Iscariot; and it is probably for the same reason that these other names are put prominently forward, as on one occasion when his name Judas is used, a parenthesis is added, "not Iscariot." He was a married Apostle, and Eusebius mentions two of his grandsons who were brought before Domitian as confessors for Christ's sake [iii. 20]. St. Jude wrote the Epistle going under his name, which is read on this day.

St. Simon Zelotes is supposed to have ministered chiefly in Egypt and parts of Africa adjoining. Some early Greek writers state that he visited Britain, and suffered martyrdom there by crucifixion. But the more probable account is that he was sawn asunder (a mode of martyrdom named in Heb. xi. 37, and that by which Isaiah is believed to have suffered) in Persia, at the same time with St. Jude, who ministered chiefly in that country, and who was martyred by the Magi.

It may be in illustration of that unity of the faith for which the Epistle of St. Jude so strongly contends, that these two Apostles, ministering and suffering, are also honoured together.

INTROIT.—Thy friends are exceeding honourable unto me, O God: greatly is their beginning strengthened. Ps. O Lord, Thou hast searched me out and known me: Thou knowest my downsitting and mine uprising. Glory be.

ALL SAINTS.

[NOVEMBER I.]

This festival is not of the highest antiquity. It appears to have originated in the Western Church at Rome in the seventh century, when the Pantheon was dedicated as a Christian church under the name of the Church of the Blessed Virgin Mary and all Martyrs. This is said to have taken place on November 1st, A.D. 608, and the festival to have been kept on that day ever since. But in the Martyrology of the Venerable Bede (though not in his Calendar) there are two days dedicated to All Saints, one on the 13th of May, "Dedicatio Sanctæ Mariæ ad Martyres," and the other on the 1st of November. In the Eastern Church, the festival of All the Martyrs is observed on the octave of Pentecost, our Trinity Sunday; and this, as it appears, since the time of St. Chrysostom, who has left a homily preached upon the day. It may well be concluded that when the number of martyrs increased so rapidly as it did in the great persecutions, Christian common sense suggested such a feast as that of All

Saints, in addition to special days of commemoration for the more illustrious martyrs; and that the dedication of the Pantheon took place on a festival already familiar to the Church, rather than as the foundation of a new one. In the Sacramentary of St. Gregory both days have Collects, &c., provided for them, that in May being entitled "Natale Sanctæ Mariæ ad Martyres," and that in November, "Natale Omnium Sanctorum," the latter having also a service provided for its vigil.

Whatever may have been the origin of the festival, it has become one very dear to the hearts of Christians, and is made, both by the character of the Service for the day, and by the meaning of it, one of the most touching of all holy days; a day on which are gathered up the fragments of the "one bread" of Christ's mystical Body, that nothing be lost of the memory and example of His Saints. First among the "cloud of witnesses" are they of the white-robed army of martyrs who are not otherwise commemorated, whose names are not noted in the diptychs of the Church, but are for ever written in the Lamb's book of life. Next are a multitude of those who were called to wait with St. John, rather than to follow their Master with St. Peter, but who are not less surely numbered among the children of God, and have their lot among the saints. Among that holy company are some who are dear to the memory of a whole Church; good bishops and priests, whose flocks are around them in the book of remembrance; saintly men and women, whose lives have been devoted to works of love, although not ministering at the altar; hidden saints of God, whose holiness was known within the narrowest circle on earth, but who will shine like stars in the firmament before the throne.

When the Church thanks God on this day for All Saints, many an one among them should be remembered by those who are left on earth. At the Holy Communion, and in private devotions, their names should be used in memorial before God; and prayers should be offered by those to whom they are still dear, and with whom they are still in one fellowship, that all loved ones departed may have more and more of the Light, Peace, and Refreshment which the Presence of Christ gives in Paradise.

INTROIT.—Rejoice we all in the Lord while we celebrate this day the honour of all the saints: for in them the angels have joy and give glory to the Son of God. Ps. Rejoice in the Lord, O ye righteous: for it becometh well the just to be thankful. Glory be.

HYMN.

EVENSING.—*Jesu Salvator sæculi.* H. N. 30, 57., H. A. M. 118.

MATTINS.—*Christe Redemptor omnium.*

“ From the rising of the sun even unto the going down of the same My Name shall be great among the Gentiles ; and in every place incense shall be offered unto My Name, and a Pure Offering : for My Name shall be great among the heathen, saith the LORD of hosts.”—MALACHI i. 11.

“ This do in remembrance of Me.”—LUKE xxii. 19.

“ He that eateth Me, even he shall live by Me.”—JOHN vi. 57.

“ In the midst of the throne, and of the four living creatures, and in the midst of the elders, stood a Lamb, as it had been slain.”—REVELATION v. 6.

INTRODUCTION TO THE LITURGY.

In the ancient Church of England, as in all other branches of the Western Church, the Celebration of the Holy Communion, and the Office for its celebration were designated by the common name of "Missa¹," the true technical meaning of which word is probably the "Offering," and which assumed the form of "Mass" in the vernacular tongue. This name was retained in 1549, the title of the Office in the Prayer Book of that date being, "The Supper of the Lord, and the Holy Communion, commonly called the Mass;" but it was dropped in 1552, has not since appeared in the Prayer Book, and has been generally disused in the Church of England as a name either for the Office or the Rite: the latter being most frequently called the Holy Communion, or the Holy Eucharist, and the Office being conveniently distinguished by the Primitive name of "The Liturgy." This

latter word appears to have been derived from classical Greek through the Septuagint. *Λειτουργία* originally signified the public duties, or office, of any *Λειτουργός*, or public officer, and especially of those persons who had to undertake the principal care and expense of public entertainments. In the Septuagint, the use of the word was restricted to the public Service of the Sanctuary [Numb. iv. 12, 26. 1 Chron. xxvi. 30]; and in the New Testament it passes on to the Christian Divine Service, which, during that age, and until the destruction of the Jewish system, consisted almost entirely of the celebration of the Holy Communion. In the Primitive Church, "The Liturgy" meant both the Office and the Rite itself, just as "Mass" did in the Mediæval Church; but in more recent times it has been restricted to the Office alone³.

THE HISTORY OF THE LITURGY.

Like the rest of the Prayer Book, the English Liturgy is an inheritance from former ages. It was principally translated, in the first instance, from the *Ordinarium Missæ*, and *Canon Missæ* of the Salisbury Use, which had been the chief rule of Divine Service in the Church of England, from A.D. 1085 to A.D. 1549, a period of nearly five hundred years. The Mass of the Salisbury Rite (as well as of other English rites, such as those of York, Hereford, Bangor, and Lincoln) was a revised form of a more ancient Service, which had been in some very slight degree influenced by the Roman under St. Augustine and his successors, but which substantially represented the Liturgy used also in the Churches of France and Spain: and this Liturgy was derived from the great Patriarchate of Ephesus, which was founded by the Apostle St. Paul, and ruled by the Apostle St. John for many years before his death². To understand this independent primitive origin of the English Liturgy, it will be necessary to trace out shortly the course of liturgical history from the first.

When our Blessed Lord instituted the Sacrament of the Holy Communion, and commanded it to be perpetually celebrated, He used the words, "This do in remembrance of Me," and thus imposed a certain form upon the Apostles as the one which they were to use in its celebration, and which would ever after be considered as essential by them, and the rest of the Church, as was the form given by Christ for Holy Baptism. This essential nucleus of the Liturgy consisted of at least Benediction, the breaking of the Bread, the giving of thanks, and the taking of the Cup into the hands, as is seen from the Gospel narrative [Matt. xxvi. 22. Mark xiv. 22. Luke xxii. 19]; and also from the special revelation made to St. Paul [1 Cor. xi. 23, 24].

¹ "Missa" is a name of great antiquity, being found in an Epistle of St. Ambrose to his sister Marcellina [Opera ii. 853, Bened. ed.]. Many explanations of the word have been given, but that of Cardinal Bona seems the most reasonable, viz. that it is derived from the words "Ite missa est," with which the congregation is dismissed by the deacon at the conclusion of the service; and which are equivalent to the "Let us depart in peace" of the Eastern Liturgies. That the term comes from "mittendo" is equally clear, and as early as Micrologus we find the explanation "In festis diebus, Ite missa est, dicitur, quia tunc generalis conventus celebrari solet, qui per hujusmodi denuntiationem licentiam discendi accipere solet" [xlvii.]. St. Thomas Aquinas explains the word as meaning that the sacrifice of the Holy Eucharist has been sent up to God by the ministrations of angels [iii. qu. 83, art. iv.]: and as *ποιεῖν*, "do this," is well known to have a technical association with sacrifice, so doubtless has "missa."

² See pp. xvii, xviii, of the Historical Introduction.

But as the words with which our Lord "blessed" the elements, and with which He "gave thanks," are not recorded, it can only be concluded that He left them to the inspired memory of His Apostles; to whom, at the proper time, the Holy Spirit was to call all things to remembrance that our Lord had taught them for the work which they had to do. It may well have been, also, that further details respecting the celebration of this principal rite of the Church were among those "things pertaining to the kingdom of God" which our Lord communicated to the Apostles during the forty days between His Resurrection and Ascension.

There is, however, no strong evidence that the Apostles adopted, or handed down, one uniform system of celebrating the Holy Communion, except in respect to these central features of the rite. Proclus, Patriarch of Constantinople in the fifth century, asserts that the Apostles arranged a Liturgy before they parted for their several fields of labour [see Bona, Rer. Liturg. I. v. 3], and a passage from a Homily of St. Chrysostom [Ad Cor. xxvii. 7], in which he says, "Consider, when the Apostles partook of that holy supper, what they did? Did they not betake themselves to prayers and hymns?" has been supposed to signify the same settled character of the Liturgy which they used. On the other hand, St. Gregory appears to say [Ep. lxiii.]; that the Apostles used only the Lord's Prayer in consecrating the holy oblation; and although it is certain his words must not be taken strictly, they may be considered to show that the Apostolic form of Liturgy was not originally a long one. Bona considers that the diversity in the evidence may be reconciled by supposing that the Apostles used a short form (containing only the essential part of the rite), when danger or other urgent circumstances gave them time for no more; and that when time permitted they used a longer form; although even this longer form he believes must have been short, compared with the Liturgies afterwards used, on account of the difficulties which Christians experienced in celebrating Divine Service during the age of persecutions. Several early liturgical commentators allege that the development of the Liturgy was gradual; and the truth seems, to be expressed by one of them when he says, that the Lord Himself instituted the rite in the simple manner narrated in the Gospel, that the Apostles added some things to it (as, for example, the Lord's Prayer), and that

³ Inexact writers sometimes designate the whole of the Offices used in Divine Service by the name of "the Liturgy," but it is much more proper, as well as convenient, to limit the use of the word as above.

then some of their successors appointed Epistles and Gospels to be read; others, hymns to be sung; and others, again, made such additions to the Liturgy from time to time as they considered suitable for contributing to the glory of God in the holy Sacrament¹. The Gospels and Epistles were certainly not written until a Liturgy had been in use for many years, in some form.

The ancient Liturgies which remain, show, nevertheless, so much general agreement as to bring conviction to the mind that they were all of them originally derived from some common source; and the same kind of synthetic criticism which traces back all known languages to three original forms of speech, can also trace back the multitude of differing Liturgies which are used by the various Churches of East and West to a few,—that is to say, four or five,—normal types, all of which have certain strong features of agreement with each other, pointing to a derivation from the same liturgical fountain. That there is any difference at all in these may be attributed probably to three causes: (1) That the Apostles did not limit themselves or others solely to the use of the central and essential portion of the rite; and that while this was substantially kept uniform by them all, each added such prayers as he saw fit. (2) That Liturgies were, to a certain extent, adapted to the circumstances of the various nations among whom they were to be used, by such changes in the non-essential portions, and such additions, as appeared desirable to the Patriarch or Bishop. (3) That as Liturgies were not committed to writing until the end of the second century², diversities of expression, and even greater changes, would naturally arise, among the variety of which it would be impossible to recover the exact original, and therefore to establish an authoritative uniformity.

It may be added that the lawfulness of an authorized diversity in non-essential rites, when combined with an orthodox uniformity in those which are essential, has always been recognized by the Catholic Church³; and that this principle is stated in the 34th Article of Religion of the Church of England.

Of the many Liturgies which are very ancient there are several which undoubtedly belong to the primitive age of Christianity, and from these all others that are known (as has been already said) have evidently branched off. They are the Liturgies which go by the names of St. James, St. Mark, St. Peter, and St. John; the first was the Liturgy of Jerusalem, the second of Alexandria, the third of Rome, and the fourth of Ephesus⁴.

The *Liturgy of St. James*, or of *Jerusalem*, was that used in Palestine and Mesopotamia, the dioceses of both which countries were included within the Patriarchate of Antioch. A singular proof of its primitive antiquity is found in the fact that the Monophysite heretics, who now occupy all these dioceses, use a Syriac Liturgy which they attribute to St. James, and which is nearly identical with that attributed to him by the orthodox, between whom and the Monophysites there has been no intercommunion since the Council of Chalcedon, which was held A.D. 451. Such a coincidence goes far to prove that this Liturgy is at least fourteen centuries old, and also offers some evidence that it was the one in use by the Churches of the Patriarchate of Antioch before the great division which arose out of the Eutychian heresy. The Liturgy of St. James is also mentioned in the 32nd Canon of the Constantinopolitan Council held in Trullo, A.D. 691; and traces of it are to be found in the writings of Fathers who lived or had lived within the Patriarchate of Antioch, and may thus be supposed to have been familiar with its words. Among such are Theodoret, St. Jerome, St. Chrysostom (once a priest of Antioch), and St. Cyril, Bishop of Jerusalem, two of

whose Catechetical Lectures (preached in the latter half of the fourth century) are expressly on the subject of the Holy Eucharist, and describe the Service minutely. In the Apostolical Constitutions, written in the third century, there is a Liturgy, or synopsis of one, which has been called by the name of St. Clement, but appears to be that of St. James; and with the latter also agrees the description of the celebration of the Eucharist which is given by Justin Martyr, who was a native of Samaria (within the Patriarchate of Antioch), and died about sixty years only after St. John⁵. From this evidence it appears almost certain, that the Liturgy of St. James which is used by the Monophysites, and that which is used on the feast of St. James by the orthodox Church of Jerusalem, are versions of the primitive Liturgy which was used for the celebration of the Holy Communion in Judæa and the surrounding countries in the age which immediately followed that of the Apostles. From it St. Basil's Liturgy was derived, and from St. Basil's that of St. Chrysostom, which is the one used at the present day in the Eastern Church, and in Russia.

The *Liturgy of St. Mark*, or of *Alexandria*, is known to have been used by the orthodox Churches of North-eastern Africa down to the twelfth century, and is still used in several forms by the Monophysites, who supplanted them. The most authentic form of it is that entitled, "The Liturgy of Mark which Cyril perfected," and which is extant in the Coptic, or vernacular language of Egypt, as well as in Greek, in MSS. of very ancient date. This Liturgy is traceable, by a chain of evidence similar to that mentioned in the preceding paragraph, to the second century, to which date it is assigned by Bunsen⁶. Palmer says respecting it, "We can ascertain with considerable certainty the words and expressions of the Alexandrian Liturgy before the Council of Chalcedon, A.D. 451; and we can trace back its substance and order to a period of far greater antiquity. In fact, there is nothing unreasonable in supposing that the main order and substance of the Alexandrian Liturgy, as used in the fifth century, may have been as old as the Apostolic age, and derived originally from the instructions and appointment of the blessed Evangelist⁷."

The *Liturgy of St. Peter*, or of *Rome*, is found, substantially as it is used in the Latin Church at the present day, in the Sacramentaries of St. Gregory [A.D. 590], Gelasius [A.D. 491], and St. Leo [A.D. 483], although many additions have been made to it in later times. The Roman Liturgy is attributed to St. Peter by ancient liturgical commentators, who founded their opinion chiefly upon a passage in an Epistle of Innocent, Bishop of Rome in the fifth century, to Decentius, Bishop of Euzabium⁸. But no doubt St. Innocent refers to the "Canon of the Mass" (as it has been called in later ages), that part of the Office which begins with the actual consecration of the Sacrament. There seems no reason to believe that this confident opinion of so eminent a Bishop in the fifth century was otherwise than correct; and like the preceding Liturgies, that of Rome may reasonably be assigned to the age succeeding the Apostles. St. Gregory revised the variable parts of this Liturgy, the Collects, Epistles, and Gospels; but the only change which he made in the Ordinary and the Canon

⁵ Justin Martyr describes the celebration of the Holy Eucharist, about A.D. 140, in the following terms:—"Upon the day called Sunday we have an assembly of all who live in the towns or in the country, who meet in an appointed place; and the records of the Apostles, or the writings of the Apostles, are read, according as the time will permit. When the reader has ended, then the Bishop [*ὁ πρῶτος*] admonishes and exhorts us in a discourse that we should imitate such good examples. After that we all stand up and pray, and, as we said before, when that prayer is ended bread is offered, and wine and water. Then the Bishop also, according to the authority given him [*δοῦναι δὲ αὐτῷ*], sends up [*ἀναπέμνει*, cf. *missa est*] prayers and thanksgivings; and the people end the prayer with him, saying, Amen. After which, distribution is made of the consecrated elements, which are also sent by the hands of the deacons to those who are absent." [Justin. Mart., Apol.]

⁶ *Analecta Ante-Nicæna* iii. 106.

⁷ *Origin. Liturg.* i. 105.

¹ *Gemma Animæ*, i. 86. Walafrid. *Strabo de Rebus Ecclæs.* xxii.

² This rule was observed from feelings founded on our Lord's words, "Give not that which is holy unto the dogs, neither cast ye your pearls before swine." [Matt. vii. 6.] For the same reason great reserve was used in speaking and writing on the subject of the Holy Eucharist, and hence little can be learned from the Fathers of the first three centuries about the mode in which it was celebrated.

³ See, e.g., St. Gregory's Epistle to St. Augustine, p. xviii of the Historical Introduction.

⁴ To these Dr. Neale adds that of St. Thaddeus, used in Persia, and also called the Liturgy of the East.

⁸ "Si instituta ecclesiastica, ut sunt a beatis apostolis tradita, integra vellent servare Domini sacerdotes, nulla diversitas, nulla varietas in ipsis ordinibus et consecrationibus haberetur—quis enim nesciat, aut non advertat, id quod a principe apostolorum Petro Romanæ Ecclesiæ traditum est. . . ." [Labbe, *Council. ii.* 1245.] Cardinal Bona remarks on a similar passage from St. Isidore's writings, "Hoc de re et substantia, non de verborum tenore et ceremoniis intelligendum est." [Rer. Liturg. I. vii. 5.]

was by that addition of a few words which is noticed by the Venerable Bede [see p. 13, note]. From the Roman Liturgy in its primitive form were derived that used by the Churches of North-western Africa, and the famous Ambrosian Rite which is used in the Church of Milan. Since the time of St. Gregory this Liturgy has been used over a large part of the Western Church, and is now the only one allowed by the See of Rome.

The *Liturgy of St. John*, or of St. Paul, i. e. the *Ephesine Liturgy*, was the original of that which was used, probably in three various forms, in Spain, France, and England during the earlier ages of Christianity, and the only one besides the Roman which obtained a footing in the Western Church. This appears to have been disused in the dioceses of which Ephesus was the centre, at the time of the Council of Laodicea in Phrygia some time in the fourth century: the nineteenth Canon of that Council giving such directions respecting the celebration of the Holy Communion as show that it substituted the Liturgy of St. Basil and St. Chrysostom, which is still used in those dioceses. But, at a much earlier date, missionaries had gone forth from the Church of Ephesus, and had planted the standard of Christianity at Lyons, that city thus becoming the great centre from which the Church spread itself throughout France; and as late as A.D. 177, the Christians of Lyons wrote to the Churches of Asia respecting the martyrdoms which had occurred in that city as to those who represented their mother Church, and had therefore a special sympathy with them. The primitive Liturgy of Ephesus thus became that of France, and, probably by the missionary work of the same apostolic men, of Spain also. This Liturgy continued to be used in the French Church until the time of Charlemagne [A.D. 742—841]. It had received such additions from the hands of Musæus, Sidonius, and St. Hilary of Poitiers, as St. Gregory had made to the Roman rite, but these additions or alterations did not affect the body of the Liturgy, consisting, as they did, of Introits, Collects, and other portions of the Service belonging to that which precedes the Ordinary and Canon.

The Gallican Liturgy was partly supplanted by the Roman in the time of Pepin, who introduced the Roman chant and psalmody into the Churches of France; and it was altogether superseded by Charlemagne, who obtained the Sacramentary of St. Gregory from Rome, and issued an edict that all priests should celebrate the Holy Sacrament only in the Roman manner. In Spain the same Liturgy had been used in a form called the Mozarabic; but by the influence of Pope Gregory VII., Alphonso VI., King of Castille and Leon, was persuaded to do as Charlemagne had done in France, to abolish the use of the national rite and sub-

stitute that of the Roman Church. It was thus wholly discontinued until the beginning of the sixteenth century, when Cardinal Ximenes endowed a college and chapel for the use of it at Toledo, and there it still continues to be used.

The early connexion between the Church of France and the Church of England was so close, that there can be no reasonable doubt of the same Liturgy having been originally used in both countries. When St. Augustine came to England in A.D. 596, expecting to find it an altogether heathen land, he discovered that there was an ancient and regularly-organized Church, and that its usages were different in many particulars from those of any Church with which he had been previously acquainted [see p. xvii]. By the advice of St. Gregory he introduced some changes into the Liturgy which he found in use; the changes coming, not directly from the Roman Sacramentary of St. Gregory, but "from a sister rite, formed in the south of France by the joint action, probably, of St. Leo and Cassian, about two hundred years before [A.D. 420]; having a common basis, indeed, with the Roman Office, but strongly tinged with Gallican characteristics derived long ago from the East, and probably enriched, at the time, by fresh importations of Oriental usages¹." Thus the Liturgy of the Church of England after St. Augustine's time became a modified form of the more ancient Gallican, which itself was originally the Liturgy of the Church of Ephesus, owing its germ to St. Paul or St. John. The English Church of St. Augustine's day, and long after, distinctly averred that its customs were derived from the latter Apostle; but in many particulars the work of St. John and St. Paul appears to have traversed the same ground, as it certainly did in the Church of Ephesus, and probably did in the Church of England.

The Liturgy thus derived from the ancient Gallican, and the more recent version of it which had been introduced by Cassian, was again revised by St. Osmund, Bishop of Salisbury, in A.D. 1085; and it was the same Liturgy which also formed the basis of the other slightly varying Offices that were used in different Dioceses of England, and have come down to us by the names of these Dioceses. The Salisbury Liturgy eventually supplanted all the others which were used by the Church of England, and became the principal basis of the vernacular Liturgy which has now been used for more than 300 years in all the churches of the Anglican communion².

The historical particulars thus given respecting the connexion between ancient and modern Liturgies may be conveniently reduced into one general view by a tabular form:—

§ Table showing the origin of the principal Liturgies used throughout the Church.

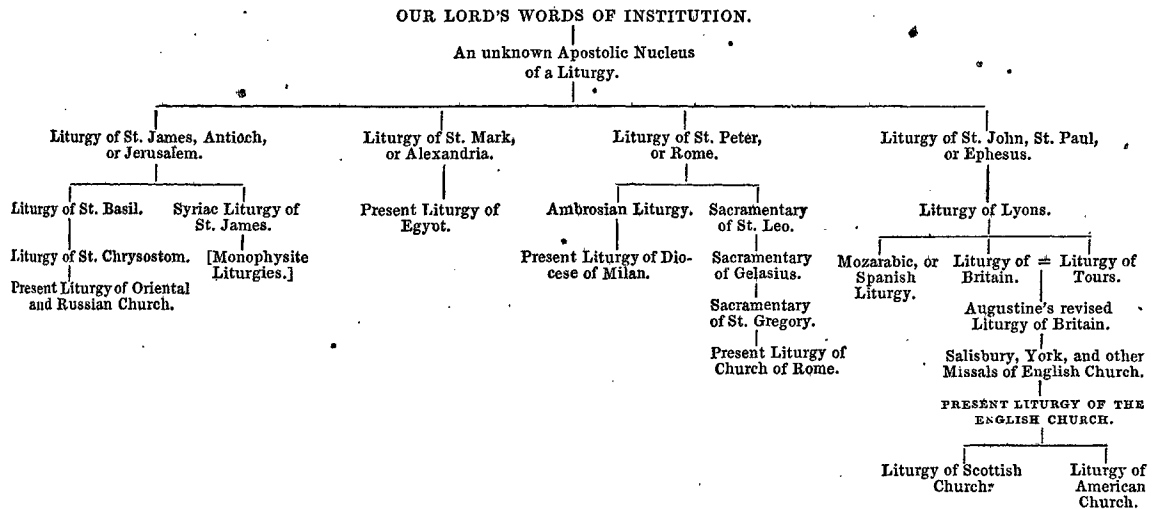

¹ Archd. Freeman's Principles of Div. Serv. II. ii. 405.

² The Roman Liturgy was never used by the Church of England; and it

was only adopted by the English sect of Romanists about a hundred and fifty years ago.

§ *Structure of Primitive Liturgies.*

In all the primitive Liturgies there is a consistency of structure which shows that they were based on one common model, or else on certain fixed principles. They consist of two principal portions, the Pro-Anaphora and Anaphora. The Anaphora, or Oblation, is represented in the Latin Liturgies by the Canon of the Mass, and in our English Office by the part which begins with the versicle, "Lift up your hearts." The Pro-Anaphora is represented by the Ordinary of the Mass, which is all that goes before the *Sursum Corda*. The general structure of each of these portions of the Liturgy is as follows, the respective portions of the several parts varying, however, in different Liturgies:—

The Pro-Anaphora.

The Prefatory Prayer.
 The Introit [known by various names].
 The Little Entrance, or bringing the book of the Gospels in procession to the Altar.
 The Trisagion.
 The Epistle and Gospel.
 The Prayers after the Gospel [after these prayers the Catechumens left the Church, and only "the faithful" or baptized and confirmed persons remained].
 The Great Entrance, or bringing the Elements in procession to the Altar.
 The Offertory.
 The Kiss of Peace.
 The Creed.

The Anaphora.

The Triumphal Hymn [*Tersanctus*] with its Preface. These come in between two portions of a long Prayer, called the Prayer of the Triumphal Hymn.

Commemoration of the Institution.
 The Words of Institution.
 Oblation of the Consecrated Elements.
 Prayer for the Descent of the Holy Ghost.
 Prayer for the Transmutation of the Elements,
 Prayer for the living and the departed.
 The Lord's Prayer, preceded by a prayer of preparation, and followed by the *Embolismus*.
 Adoration, with an appointed prayer.
 Elevation.
 Union of the two Consecrated Elements.
 Prayer of humble access.
 Communion.
 Thanksgiving.

Without going into very great detail it is impossible to show the elaborate character of the ceremonial, and of the responsive part of the primitive Liturgies. These details may all be found in the original languages, and also in Dr. Neale's translation of the Primitive Liturgies; and it is sufficient here to say, that the early Christians appear to have had no thought of what is called "simplicity" in Divine Worship, their Liturgies exhibiting a complicated structure, much ceremony, and an elaborate symbolism. All of them agree in the above general characteristics, but there are variations in the order of the different parts, the chief of which are represented in the following table:—

§ *Table showing the order in which the principal features of the Primitive Liturgies occur.*

<i>St. James.</i>	<i>St. Mark.</i>	<i>St. Peter.</i>	<i>St. John.</i>
1. Kiss of Peace.	1. Kiss of Peace.	2. Lift up your hearts.	7. Prayer for the living.
2. Lift up your hearts.	2. Lift up your hearts.	3. <i>Tersanctus</i> .	8. Prayer for the departed.
3. <i>Tersanctus</i> .	7. Prayer for the living.	7. Prayer for the living.	1. Kiss of Peace.
4. Commemoration of Institution.	8. Prayer for the departed.	6. Prayer for descent of the Holy Ghost.	2. Lift up your hearts.
5. The Oblation.	3. <i>Tersanctus</i> .	4. Commemoration of Institution.	3. <i>Tersanctus</i> .
6. Prayer for descent of the Holy Ghost.	4. Commemoration of Institution.	5. The Oblation.	4. Commemoration of Institution.
7. Prayer for the living.	5. The Oblation.	8. Prayer for the departed.	5. The Oblation.
8. Prayer for the departed.	6. Prayer for descent of the Holy Ghost.	10. Union of the Consecrated Elements.	6. Prayer for descent of the Holy Ghost.
9. The Lord's Prayer.	10. Union of the Consecrated Elements.	9. The Lord's Prayer.	10. Union of the Consecrated Elements.
10. Union of the Consecrated Elements.	9. The Lord's Prayer.	1. Kiss of Peace.	9. The Lord's Prayer.
11. Communion.	11. Communion.	11. Communion.	11. Communion.
12. Thanksgiving.	12. Thanksgiving.	12. Thanksgiving.	12. Thanksgiving.

It will be seen at once that the order of St. John, or the Ephesine Liturgy, is that which is most closely represented by our own Communion Office. The same correspondence between the two may also be traced in several particulars, in which the Liturgy of St. John differs from the other two Eastern Liturgies; especially in the provision of varying collects, and proper prefaces, and in the use of the versicle, "Glory be to Thee, O Lord," before the Gospel.

The Liturgy of St. John was handed down (as has been already stated) through the French Church, to which it was conveyed from Ephesus by missionaries, at a period very near to that of the Apostles themselves. The Gallican Liturgy itself is thus described by Palmer [Orig. Liturg. i. 158], "Germanus informs us, that the Liturgy began with an Anthem, followed by *Gloria*

Patri, after which the Deacon proclaimed silence; and a mutual salutation having passed between the priest and people, the hymn *Trisagios*, in imitation of the Greek rite, was sung, and was followed by *Kyrie eleison*, and the song of Zacharias the prophet beginning *Benedictus*, after which the priest read a collect, entitled *Post prophetiam*, in the Gallican missals. The office so far; though ancient, cannot be traced to the most primitive ages of the Gallican Church, as doubtless the Liturgy originally began with the lessons from Holy Scripture, which I now proceed to consider.

"A lesson from the prophets or Old Testament was first read, then one from the Epistles, which was succeeded by the hymn of the three children, *Benedicite*, and the Holy Gospel. In later times the book of the Gospels was carried in procession to the pulpit by the Deacon, who was accompanied by seven men bearing lighted tapers, and the choir sung Anthems before and after the Gospel. After the Gospel was ended, the Priest or Bishop preached, and the Deacon made prayers for the people (probably in imitation of the Greek Liturgies, where a litany of the kind

¹ It is almost needless to say that Dr. Neale's works on the Eastern Church and the Primitive Liturgies should be referred to by those who wish for further details.

occurs after the Gospel), and the Priest recited a collect *Post preces*.

"Then the Deacon proclaimed to the catechumens to depart, but whether any previous prayers were made for *them* seems doubtful. Germanus speaks of its being an ancient custom of the Church to pray for catechumens in this place, but his words do not absolutely prove that there were particular prayers for them in the Gallican Church, and no other author refers to the custom, as far as I am aware. The catechumens, and those under penitential discipline, having been dismissed, silence was again enjoined, and an address to the people on the subject of the day, and entitled *Prefatio*, was recited by the Priest, who then repeated another prayer. The oblations of the people were next received, while the choir sang an offertory anthem, termed *sonum* by Germanus. The elements were placed on the holy table, and covered with a large and close veil or pall, and in later times the Priest here invoked the blessing of God on the gifts.

"Then the tablets called *diptychs*, containing the names of the living and departed saints, were recited, and the Priest made a collect, 'post nomina.' Then followed the salutation and kiss of peace; after which the Priest read the collect, 'ad pacem.' The mystical liturgy now commenced, corresponding to the Eastern 'prophora,' or 'anaphora,' and the Roman *preface* and *canon*. It began with the form 'sursum corda,' &c., and then followed the preface, or thanksgiving, called 'contestatio,' or 'immolatio,' in which God's benefits to the human race were variously commemorated; and at the proper place the people all joined in singing the hymn *Tersanctus*.

"The thanksgiving then continued in the form called 'post sanctus,' which terminated with the commemoration of our Saviour's deed and words at the institution of this sacrament. Afterwards the Priest recited a collect entitled 'post mysterium,' or 'post secreta,' probably because the above commemoration was not committed to writing, on account of its being esteemed to have great efficacy in the consecration. The collect, 'post mysterium,' often contained a verbal oblation of the bread and wine, and an invocation of God to send His Holy Spirit to sanctify them into the sacraments of Christ's body and blood. After this the bread was broken, and the Lord's Prayer repeated by the Priest and people, being introduced and concluded with appropriate prayers, made by the Priest alone.

"The Priest or Bishop then blessed the people, to which they answered, Amen. Communion afterwards took place, during which a psalm or anthem was sung. The Priest repeated a collect of thanksgiving, and the service terminated."

It was on this rite that the Eucharistic customs of the Church of England were founded, although they were plainly revised and altered at several periods, and in several dioceses; as, for example, by St. Augustine in the seventh century, and St. Osmund in the eleventh.

§ *The Mediæval Liturgy of the Church of England.*

As, in the early Church throughout the world, there were various forms of the Liturgy, all having a substantial unity, so while England was divided into several distinct districts, by dialect and civil government, the form of Liturgy which was used in various parts of the country was affected by local circumstances; especially as each diocese had the right of adopting (within certain limits) its own particular customs, or "use" in Divine Service, until the sixteenth century.

Soon after the Conquest, however, about the year 1085, a great liturgical successor of St. Gregory arose in the person of Osmund, Bishop of Salisbury, of whom we know little beyond the fact that he revised the Breviary and Missal, and brought both into a form which commended itself to a large portion of the Church of England, and even to some foreign dioceses. There were, indeed, independent Breviaries and Missals of York, Hereford, Bangor; Lincoln, and perhaps other churches; but those of Salisbury were the most generally used throughout the southern counties, and before the sixteenth century the Missal of that diocese came to be called, in some editions, "Missale secundum usum Ecclesiæ Anglicanæ." In 1541-2, the Missal as well as

other books of the use of Sarum were formally adopted for the whole province of Canterbury by an act of Convocation. Notwithstanding the variations that had so long existed in the ritual customs of different districts and dioceses, it must not be supposed that these variations extended to any *essential* matters. On the contrary, there was a distinct generic identity, which showed that all were, in reality, local forms of one great national rite, that rite itself being a branch of one great Catholic system; and this was especially the case with the Communion Office or Liturgy.

The substance of the Salisbury Liturgy is given in the Appendix to the Communion Office, but it is necessary to give some account of it here to show the manner in which the Church of England celebrated the Holy Communion from A.D. 1080 to A.D. 1549. Many further illustrations of it, and of the other English uses, as well as of the connexion between them and our present Communion Office, will be found in the subsequent notes.

The Mediæval Liturgy of the Church of England was made up, like all others, of the two great divisions which are called in the Eastern Church the Pro-Anaphora and the Anaphora, and in the Western Church, the Ordinarium and the Canon; the former part ending with the Sanctus, the latter part beginning with the Prayer of Consecration and Oblation.

The first portion of the Ordinary consisted of the hymn "Veni Creator," the Collect, "Almighty God, to whom all hearts be open," the forty-third Psalm, "Give sentence with me, O God," the lesser Litany and the Lord's Prayer, all of which were said in the vestry while the Celebrant was putting on his albe, chasuble, &c. The public part of the service began with the "Officium," or Introit, of which many examples are given in the notes to the Epistles and Gospels, and which was sung (in the manner described at p. 71) while the Celebrant and his ministers were going from the vestry to the altar. After this followed the Confession and Absolution, said as at Prime and Compline, and as described in a note at p. 5, the Gospeller and Epistoler taking part with the choir in the alternate form used. This mutual confession of unworthiness was sealed with a kiss of peace given by the Celebrant to the Deacon and Sub-deacon¹, and burning incense having been waved before the altar by the former, the "Gloria in Excelsis" was sung (except at certain seasons) as the solemn commencement of the rite. The Mutual Salutation [see p. 22] was then said, and after that the Collect of the Day, the Epistle and Gospel, and the Nicene Creed. The Gospel was preceded by a procession with singing [the Gradale], somewhat similar to the "little entrance" of the Eastern Church [p. 148], and was generally read (in large churches) from the "Jube" or "pulpit," a desk placed between the cross and the chancel wall on the rood-loft. The Nicene Creed was followed by the Offertory, the solemn Oblation of the Elements, short supplications that the sacrifice might be acceptable to God for the living and the departed, and certain private prayers of the Celebrant, with which the first part of the Service, or Ordinarium, may be said to have ended.

The Canon of the Mass was introduced by the Apostolic verses, the Proper Preface, and the Tersanctus, which we still use in the same place; and then followed a long prayer, interspersed with many ceremonies, but substantially equivalent to the "Prayer for the Church Militant," the "Consecration Prayer," and the first "Thanksgiving Prayer" of our modern English Liturgy. This will be found given at length in the Appendix to the Communion Office.

The prayer of Consecration was not immediately followed by the Participation as in our modern Liturgy. First came the Lord's Prayer, preceded by a short preface, and followed by a prayer for deliverance from all evil, analogous to the Embolismus of the Eastern Church [p. 6]. Then came the Agnus Dei, sung thrice, in the same manner as it is sung twice in the modern Litany. After the Agnus Dei followed the ceremony of the commixture of the consecrated elements, by placing a portion of the wafer into the chalice, in symbolical signification of the union of

¹ This is peculiar to the Sarum and Bangor rites, not being found in any other Liturgy in this part of the service.

natures in our Lord. The Kiss of Peace was then passed round from the Celebrant by means of his ministers (the Deacon and Sub-deacon, or Epistoler and Gospeller), some private prayers were said by the Celebrant, and afterwards the prayer of Humble Access.

Here came in the Communion, first of the Celebrant, and then of the other Clergy and of the people¹; and, with the exception of a Thanksgiving Prayer and a Post-Communion Collect, this substantially completed the Service.

There were, however, some subsequent ceremonies, such as the ablution of the sacred vessels, and of the Celebrants' hands, which are left to traditional practice and individual devotion in our modern English rite, but which were provided for with minute exactness in the ancient one. During these ceremonies the congregation still remained, and after their conclusion were dismissed by the Deacon saying, *Benedicamus Domino*, or, *Ite, missa est*, according to the season.

There is no reason to think that this mode of celebrating the Holy Communion underwent any great changes from the time of St. Osmund until 1549; and indeed it was probably very much the same as had been used in the Church of England even before the time of St. Osmund. Many ceremonies were doubtless introduced during the Middle Ages, and some had probably been added by St. Osmund himself; but these ceremonies affected the rubrics rather than the substance of the Liturgy, and the Ordinary and Canon were otherwise in the same condition in the sixteenth century that they had been in the eleventh. It must, however, be remembered that numerous additions were made to the variable parts of the Missal [p. 68], special Collects, Epistles, and Gospels, &c., being appointed for particular days and occasions; and it was in these additions that the Reformers found so much which they regarded as inexpedient or superstitious. What the great French liturgical scholar, Gueranger, says respecting the MSS. of the Roman Liturgy was doubtless true, to some extent, of the English, that they had come to be "loaded with gross and even superstitious additions, consisting chiefly of apocryphal histories, unknown and even rejected in the early ages, but which had been afterwards introduced into the Lessons and Anthems, and in votive Masses (which had become superstitiously numerous), barbarous forms, and furtively introduced Benedictions." But these abuses were far more common in the southern countries of Europe than in England; and the most conspicuous innovations connected with the celebration of the Holy Eucharist in our own Church were (1) the withdrawal of the Cup from the Laity, and (2) the rare communion of the Laity under any circumstances except at the approach of death.

In respect to the first, it is sufficient to say, that although the Eucharist appears to have been always sent to the sick under the form of one element only, until 1549, the Laity were certainly accustomed to partake of it in both kinds at church until the twelfth century. Even so late as A.D. 1175, the Convocation of Canterbury forbade the introduction of the novel custom, and it is probable that it did not become common in England until its adoption was ordered by the Council of Constance in 1415. There is no recognition whatever of the administration in one kind in the Liturgy itself, though in an Exhortation used before the Communion of the Laity it is distinctly referred to.

The second custom arose out of that inattention to the *ἀναλογία* of doctrine which so often leads men to error in practice. The Holy Eucharist being both a Sacrifice and a Sacrament, theologians of the Middle Ages were so intent upon the duty and necessity of the first that they overlooked the duty and necessity of the second; and while the Mass was offered daily in most, if not in all, churches, and in some many times in the day, few except the Clergy ever partook of it more than once or twice in the year, considering that it was sufficient for them to be present while it was being offered.

But this too was an innovation that had found its way into practice without finding any recognition in the Liturgy. Nor

¹ The Communion of the people was preceded by an Exhortation.

can it be said that there was any thing in the authorized forms for the celebration of the Holy Eucharist which could have originally given rise, or encouragement, to either practice.

§ *The Reformed Liturgy of the Church of England.*

The general steps which were taken towards a reconstruction of all the Offices used in Divine Service, and their translation into English, have been traced out in the Historical Introduction, pages xix—xxvi, and need not be repeated in treating particularly of the Liturgy. Suffice it to say, that the abstinence of the Laity from Communion appeared so great and pressing an evil to the Reformers, that they added on an English Office for the Communion of the Laity in both kinds, to the ancient Salisbury Liturgy, even before they had finished the preparation of the Prayer Book².

The general consideration of the Theology of the Sacraments had been committed by Henry VIII. to a Commission of Divines in 1540, and the revision of the Services had also been undertaken about the same time. In 1546, shortly before his death, "the King commanded" Archbishop Cranmer "to pen a form for the alteration of the Mass into a Communion³." On November 30th, 1547, the Prolocutor of the Lower House of Convocation "exhibited, and caused to be read publicly, a form of a certain ordinance, delivered by the Most Reverend the Archbishop of Canterbury, for the receiving of the body of our Lord under both kinds, viz. of bread and wine. To which he himself subscribed, and some others, &c."⁴ The form thus approved of by Convocation was ratified by both Houses of Parliament on December 20th, 1547; and issued under a proclamation by the Crown⁵, on March 8th, 1547-8. This proclamation ordered that "the most blessed Sacrament of the Body and Blood of our Saviour Christ should from thenceforth be commonly delivered and ministered unto all persons within our realm of England and Ireland, and other of our dominions, under both kinds, that is to say, of bread and wine (except necessity otherwise require), lest every man phantasying and devising a sundry way by himself, in the use of this most blessed Sacrament of unity, there might arise any unseemly and ungodly diversity."

The "Order of Communion," thus authorized⁶, begins with an Exhortation, to be used on the Sunday or Holyday next before the Administration. This Exhortation was reproduced in the Liturgy of 1549, and is identical (except that the last paragraph is omitted) with that now standing first in our present Liturgy. After this came the following rubric, which explains the use of the Office:—"The time of the Communion shall be immediately after that the Priest himself hath received the Sacrament, without the varying of any other rite or ceremony in the Mass (until other order shall be provided), but as heretofore usually the Priest hath done with the Sacrament of the Body, to prepare, bless, and consecrate so much as will serve the people; so it shall continue still after the same manner and form, save that he shall bless and consecrate the biggest chalice, or some fair and convenient cup or cups full of wine with some water put unto it; and that day, not drink it up all himself, but taking one only sup or draught, leave the rest upon the altar covered, and turn to them that are disposed to be partakers of the Communion, and shall thus exhort them as followeth." Then follows the Exhortation beginning, "Dearly beloved in the Lord, ye that mind," &c., which replaced an older form, previously used in the same place, when the holy Sacrament was administered in one kind only. After this Exhortation the Priest was directed to "pause awhile, to see if any man will withdraw himself," and then to say

² Translations of the Epistles and Gospels of the Sarum Use had been common for some time, and a great number of them exist at the end of Primers of the period, as well as in separate volumes.

³ Strype's Memorials of Cranmer, i. 311. Ecc. Hist. Soc.

⁴ Ibid. ii. 37.

⁵ It will be remembered that Charlemagne substituted the Roman for the Gallican Liturgy by his own authority alone.

⁶ Original copies of this "Order of Communion" are extremely rare, there being only four or five known. One of these is in the Public Library, Cambridge, one in Cosin's Library, and one in Routh's Library: both the latter at Durham.

the invitation, "Ye that do truly," the Confession, the Absolution¹, the Comfortable words, and the Prayer of Humble Access. The Communion followed the latter Prayer, the Office being in these words from thence to the end:—

"Then shall the Priest rise, the people still reverently kneeling, and the Priest shall deliver the Communion, first to the Ministers, if any be there present, that they may be ready to help the Priest, and after to the other. And when he doth deliver the Sacrament of the Body of Christ he shall say to every one these words following,

"The body of our Lord Jesus Christ, which was given for thee, preserve thy body unto everlasting life.

"And the Priest delivering the Sacrament of the Blood, and giving every one to drink once and no more, shall say,

"The blood of our Lord Jesus Christ, which was shed for thee, preserve thy soul to everlasting life.

"If there be a Deacon or other Priest, then shall he follow with the chalice, and as the Priest ministereth the bread, so shall he for more expedition minister the wine, in form before written.

"Then shall the Priest, turning him to the people, let the people depart with this blessing,

"The peace of God, which passeth all understanding, keep your hearts and minds in the knowledge and love of God, and in His Son Jesus Christ our Lord.

"To the which the people shall answer,
Amen.

"Note, that the Bread that shall be consecrated shall be such as heretofore hath been accustomed. And every of the said consecrated Breads shall be broken in two pieces, at the least, or more by the discretion of the Minister, and so distributed. And men must not think less to be received in part, than in the

whole, but in each of them the whole body of our Saviour Jesus Christ.

"Note, that if it doth so chance, that the wine hallowed and consecrate doth not suffice or be enough for them that do take the Communion, the Priest, after the first cup or chalice be emptied, may go again to the altar, and reverently, and devoutly prepare, and consecrate another, and so the third, or more, likewise beginning at these words, Simili modo postquam cœnatum est, and ending at these words, qui pro vobis et pro multis effundetur in remissionem peccatorum, and without any levation or lifting up."

From March 8th, 1547-8, until June 9th, 1549, the authorized Liturgy of the Church of England consisted, therefore, of the ancient Salisbury Mass, with this "Order of Communion" in English superadded when any of the laity wished to communicate. At the end of the year and a quarter the first complete Book of Common Prayer in English was taken into use, that is, on Whit-Sunday (June 9th), 1549; and it contained a Liturgy formed from the ancient Latin and this recent English Office. The substance of the Liturgy, so reconstructed and translated, is given in the Appendix to the Communion Office; and as the history of the Liturgy is henceforth part of that of the Prayer Book itself, which has been already given in the Historical Introduction, it is unnecessary to go further into it here. The various changes which ensued in 1552, 1559, and 1661, will be shown in the foot-notes.

It need only be added, to complete the account of the English Liturgy, that it has been the source from which the modern Scottish Church has drawn its Communion Office. In this the modern Church has followed the ancient, for the Salisbury Missal, in a complete or a modified form, was used in Scotland in Mediaeval times. The American Liturgy is also an adaptation of the English; and will, as well as the Scottish, be found in the Appendix to the Communion Office.

THE DOCTRINE OF THE HOLY COMMUNION.

Before the great Sacrament of the Christian Church was actually instituted by our Blessed Lord, it was foretold and pre-figured by words and acts of His own, and by prophecies and material types of more ancient date. A due consideration of these antecedents of the Holy Communion is a great help towards a clear understanding of its true meaning and use in the Christian economy.

1. First of all is the Tree of Life in the garden of Eden. From the manner in which this is spoken of, it appears to have been a tree bearing a kind of natural Sacrament, by partaking of which as food the natural decay and fear of the physical body was so counteracted that its decay and death became impossible; a tree to which man might "put forth his hand and eat and live for ever." [Gen. iii. 22.] Of this means of life we hear again in the regenerated city of God, "the New Jerusalem coming down from God, out of Heaven, prepared as a bride adorned for her husband;" for "in the midst of the street of it, and on either side of the river, was there the tree of life, which bare twelve manner of fruits, and yielded her fruit every month; and the leaves of the tree were for the healing of the nations." [Rev. xxii. 2.]² But we also hear of it from our Lord Himself, who, about the time of the institution of the Holy Eucharist, proclaimed Himself as the "True Vine," and spoke of the Sacrament which He originated as the "Fruit of the Vine." [John xv. 1. Matt. xxvi. 29.]

2. The chosen people of God were fed for forty years, during their penal and probationary wandering in the wilderness, with manna, a mysterious "bread from heaven," to which they gave the name it bore because of its mystery, "for they wist not what it was."³ And Moses said unto them, "This is the bread which the Lord hath given you to eat." [Exod. xvi. 15.]

Of this also we hear in the Book of the Revelation, where, in His message to the Angel of the Church of Pergamos, the Lord says, "To him that overcometh will I give to eat of the hidden manna." [Rev. ii. 17.]⁴ But it had been heard of in a still more remarkable way from the lips of the same Lord, in His discourse to the people after the miracle of the loaves and fishes. When our Lord had thus "filled them with bread in the wilderness," the people, still unconvinced, asked Him for a sign, not from earth, but from Heaven, and greater than this. Moses had given them not only common bread, but even manna, "bread from Heaven," not man's, but "angel's food;" what could He do more than Moses, to convince them that He was greater than Moses? Then our Lord directed their attention to His own Person, as "the Bread of God which cometh down from Heaven and giveth life unto the world; . . . the Bread of life . . . the Bread which cometh down from Heaven, that a man may eat thereof and not die . . . the living Bread which came down from Heaven: if any man eat of this Bread, he shall live for ever: and the Bread which I will give is My flesh, which I will give for the life of the world." [John vi. 31. 51.]

3. It is impossible not to associate the manna of the wilderness with the "true Bread from Heaven," the "hidden manna," and that bread of which our Lord said, "This is My Body;"

⁴ The manna was "a small round thing . . . like coriander seed, white; and the taste of it was like wafers, made with honey . . . and the colour thereof as the colour of bdellium." [Exod. xvi. 14. 31. Numb. xi. 7.] Pious writers have seen in the sweetness of the manna a type of that Word which is "sweeter than honey" to the mouth; in its suitableness to every man's taste, of the Eucharist which is so to every man's faith; and in the sufficiency of the quantity, however much more or less had been gathered than the assigned measure, a type of the fulness of the Gift of Christ in every particle of the consecrated element. There seems to be a curious traditional memorial of the manna, and of the Passover, in Good Friday buns, which are flavoured with coriander seed. They probably represented the ancient Jewish form of Passover cakes, Christianized by the mark of the Cross; but they also represent almost exactly the loaf out of which the portions of bread to be consecrated are taken in the Liturgies of the Eastern Church.

¹ As Confession had already been made and Absolution given, in Latin, this repetition of both seems very seriously open to objection, and cannot be satisfactorily explained.

² Cf. Notes on Psalm i.

³ See margin of the passage.

with all of which is connected the idea of nourishment and life. Our Lord's words respecting this Bread from Heaven drove away many of His followers, who were impatient of a mystery which they could not understand; but when He said to the Apostles, "Will ye also go away?" the reply was, "Lord, to whom shall we go? Thou hast the words of eternal life." They continued with Him, notwithstanding this trial of their faith, and their perseverance was rewarded by the interpretative acts and words of our Lord when He instituted the Holy Communion, and showed them the inner meaning of the miracle of the loaves and of His mysterious words respecting Himself, "For My flesh is meat indeed, and My blood is drink indeed. He that eateth My flesh, and drinketh My blood, dwelleth in Me, and I in him." [John vi. 55, 56.] "Take, eat; this is My body . . . Drink ye all of it; for this is My blood." [Matt. xxvi. 27, 28.]

These antecedent types and words are the most prominent of a class which need not be referred to in further detail, since the two referred to are sufficient to show that a preparation was being made for the right understanding of that great Sacrament which our Lord instituted to be the means of spiritual life to the world. The "bread and wine" of Melchizedek's offering, the "Mincha" of the Temple Service, the "bread" and "mingled wine" of Wisdom's "table" in the book of Proverbs, the "pure offering" of the prophet Malachi, are all anticipative shadows of that which was to be revealed in the Kingdom of Christ: and many other such shadows cast their forms across the page of Holy Scripture, leading up to Him and His work, in whom and in which was to be the fulfilment of all types and figurative representations.

§ *The Holy Communion as a Sacrament.*

Thus, then, we are led up to the consideration of the rite instituted by our Lord as a new tree of life, a manna for the new chosen people, a Heavenly food, the Sacrament or Mystery of the Body and Blood of Christ.

Strange as it appeared to those who heard the truth for the first time, there must have been some absolute necessity for making the Body and Blood of Christ a healing food. What this necessity was the Holy Spirit has not yet revealed to us; but we seem to be tracing out the general outline of it, when we acknowledge that only our Lord's perfect Human Nature could remedy the imperfections of that human nature which is still subject to the influences of evil, first brought to bear upon it by the Fall. "Wherefore," says the Exhortation which follows the Prayer for the Church Militant, "it is our duty to render most humble and hearty thanks to Almighty God, our heavenly Father, for that He hath given His Son, our Saviour Jesus Christ, not only to die for us, but also to be our spiritual food and sustenance in that holy Sacrament." It is impossible to explain why our Lord's death was not sufficient for the full prospective accomplishment of His work; why it was still necessary for Him to be the spiritual food and sustenance of His people through all the ages that were afterwards coming upon the world; why He should not build up each soul into the living Temple without the intervention of any sacramental medium between the soul and His Almighty power. And since it is impossible to give a reason for this, there is the more cause to acknowledge humbly that God does nothing without necessity, and to bow our intellect with reverence before the inscrutable fact which lies open before it in Christ's words, "My flesh is meat indeed, and My blood is drink indeed." "This is My body, this is My blood."

Such a reverent awe for this great fact will not be at all diminished by inquiry as to the particular circumstances under which the Holy Eucharist was instituted, if we are careful not to give ourselves a false impression of those circumstances by yielding to the seductive bias of mere "local colouring." For however true it may be that the rite which our Lord instituted was associated with some previous custom of the temple, the synagogue, or the household, yet this truth is only part of the whole truth; and it would be a perversion of a truth to say that this association amounted to the actual foundation of the Christian

rite upon the Jewish. It is a more rational, as well as a more reverent, answer to the question, Whence was the Holy Eucharist derived? to reply that it was *absolutely originated* by our Blessed Lord, and not founded on any previous ordinance or custom. As He took our human nature into His Divine Nature by an originative act of Creation, although He was pleased to follow up the Creative act by the natural process of its development from the substance of His Mother; so an originative act preceded, and stood above, all associations between the Eucharist and earthly rites or earthly substances. His Body and His Blood first existed, and then were associated with bread and wine; the former taking the latter up into themselves by His Divine power. It is true that our Lord did use the words of David, at the most solemn epoch of His sufferings; that He associated His Prayer with ancient formularies of the older dispensation; and that He did, in like manner, associate the Holy Eucharist with the Temple rite of the Mincha offering of bread and wine, with the Sabbath Eve Synagogue Memorial of the Exodus, and with the domestic usages of the Passover. But the association in each case was that of the antitype with the type. He did not use the words of the Psalms as those of David, but David used them prophetically as the words of Christ. Those Jewish prayers which bore some resemblance to the Lord's Prayer, were typical foreshadowings of that Divine formulary in which all prayer was to be gathered into one ever-prevailing intercession; and, finally, the Eucharist was not evolved out of former rites, but fulfilled them, and absorbed them. The Mincha became the "pure offering," the Sabbath Eve service of the Synagogue merged in the Lord's Day Eucharist, and the domestic rites of the Passover passed into the Sacrament of His love, of Whom the whole family in heaven and earth is named.

Thus then we are led to look primarily not at the outward signs of the Holy Eucharist, but at that which they signified. Bread and wine, the common food and common drink, not the exceptional luxuries of a Jewish meal, were indeed used by our Lord as the media of His great gift; but it is to the gift itself that He draws our attention, saying, not "This Bread," but "This is My Body," . . . not "This Wine," but "This is My Blood." He takes them up into a higher nature; and when so consecrated, although their original nature is not annihilated, it passes out of spiritual cognizance, and the eye of faith sees, or desires to see, it no more.

Much trouble would have been spared to the Church if there had been less endeavour to define on the one hand what our Lord's words mean, and, on the other hand, what they do not mean. Up to a certain point we can define; beyond a certain point we must be content to leave definition and accept mystery. We can say that the elements before consecration are bread and wine, and we can also say that they are bread and wine after consecration; we can say that the bread and wine are *not* the Body and Blood of Christ before consecration, and we can also say that they *are* the Body and Blood of Christ after consecration. But how these apparently contradictory facts are to be reconciled, what is the nature of the change that occurs in the bread and wine, in what manner that change is effected, how far that change extends beyond the use of the Sacrament—these are questions that no one can answer but God. When Nicodemus said, "How can these things be?" and the people at Capernaum, "How can this Man give us His flesh to eat?" our Lord did not explain, but reiterated, the truths which had excited the wonder and doubt of the questioners. In doing so He doubtless taught the lesson, that when God speaks in words of mystery He does so with a purpose; and that it is our duty to believe exactly what He tells us, even though we cannot understand all that His words mean. There can never be any real antagonism between one truth and another, nor can there be any real conflict between His gift of Faith and His gift of Intellect.

§ *The Holy Communion as a Sacrifice.*

In the prophecy of Malachi to which previous reference has been made, the Holy Ghost gave the following prediction respect-

ing Gospel times:—"From the rising of the sun, even unto the going down of the same, My Name shall be great among the Gentiles; and in every place incense shall be offered unto My Name, and A PURE OFFERING: for My Name shall be great among the heathen, saith the Lord of hosts." [Mal. i. 11.] The words rendered "pure offering" are "Mincha t'hora" in Hebrew, *θυσια καθαρά* in the Septuagint, and "oblatio munda" in the Vulgate. The whole text "was once, and that in the oldest and purest time of the Church, a text of eminent note, and familiarly known to every Christian, being alleged by their pastors and teachers as an express and undoubted prophecy of the *Christian sacrifice*, or solemn worship in the Eucharist, taught by our blessed Saviour unto His disciples, to be observed of all that shall believe in His Name; and this so generally and grantedly, as could never have been, at least so early, unless they had learned thus to apply it by tradition from the Apostles." [Mede, Christian Sacrif. 355.] The deep and habitual conviction of the

truth here expressed is illustrated by the names which were given to the Holy Communion in the early Church: they were "Oblation, Sacrifice, Eucharist, Sacrifice of Thanksgiving, Sacrifice of Praise, reasonable and unbloody Sacrifice, Sacrifice of our Mediator, Sacrifice of the Altar, Sacrifice of our Ransom, Sacrifice of the Body and Blood of Christ. It would be *infinite* to note all the places and authors where and by whom it is thus called." [Ibid.] In all these terms it will be seen that the most prominent idea of the Eucharist was not that of Communion, but of Oblation or bloodless Sacrifice. And they were terms advisedly taken into use by holy men and the Church at large, at a time when sacrifices were still offered beyond the pale of the Church.

This habitual dwelling upon the Sacrificial aspect of the Eucharist was founded upon the acts and words of our Lord at His Institution of the Sacrament. These are narrated by the three former Evangelists and by St. Paul in the following passages:—

<p>Matt. xxvi. 26—28.</p> <p>And as they were eating, Jesus took bread, and blessed it, and brake it, and gave it to the disciples, and said, Take, eat; This is My Body.</p> <p>And He took the cup and gave thanks and gave it to them, saying, Drink ye all of it; for this is My Blood of the New Testament, which is shed for many, for the remission of sins.</p>	<p>Mark xiv. 22—24.</p> <p>And as they did eat, Jesus took bread, and blessed, and brake it, and gave to them, and said, Take, eat; This is My Body.</p> <p>And He took the cup and when He had given thanks He gave it to them; and He said unto them, This is My Blood of the New Testament, which is shed for many.</p>	<p>Luke xxii. 19, 20.</p> <p>And He took bread and gave thanks, and brake it, and gave unto them, saying, This is My Body which is given for you: this do in remembrance of Me. Likewise also the cup after supper saying, This cup is the New Testament in My Blood, which is shed for you.</p>	<p>1 Cor. xi. 23—25.</p> <p>The Lord Jesus took bread: and when He had given thanks, He brake it, and said, Take, eat; This is My Body which is broken for you: this do in remembrance of Me. After the same manner also He took the cup when He had supped, saying, This cup is the New Testament in My Blood: This do ye, as oft as ye drink it, in remembrance of Me.</p>
---	--	--	--

In these narratives certain definite acts and words of our Lord are clearly recorded. (1) He took bread: (2) He blessed it, or "gave thanks" over it: (3) He brake it: (4) He gave it to those present: (5) He said that what He so gave them to eat was His Body: (6) He took the cup: (7) He gave thanks over it also: (8) He gave it to those present: (9) He called that which He so gave them to drink His Blood: (10) He directed them to do as He had done for a memorial of Him.

In the words recorded there are several terms of a special character. (1) When our Lord blessed [*εὐλογῆσας*] and gave thanks [*εὐχαριστήσας*], He did so in no ordinary sense, as in the benediction of food before a meal, or the thanksgiving for it afterwards. He blessed the elements of bread and wine with the fulness of a Divine benediction, so that His eucharistization of them caused them to possess properties which they did not previously possess; especially, to become spiritual entities, His Body and His Blood¹. (2) In commanding His Apostles to "do" [*ποιεῖτε*] "this," our Lord was using a well-known expression significant of the act of Sacrifice; and one which St. Paul (who uses it twice of the Institution) uses also of the Passover, when he says of Moses, that "through faith he kept [*ἐποιήσε*] the Passover and sprinkling of blood." The use of the word for both is found afterwards

in St. Chrysostom, when he writes, "See how He weans and draws them from Jewish rites; 'For,' says He, 'as ye offered that'" (i. e. the Passover, *ἐκεῖνο ἐποιεῖτε*) "in remembrance of the miraculous deliverance from Egypt, so offer" (*ποιεῖτε*) "'this in remembrance of Me: that blood was shed for preservation of the first-born, this for the remission of the sins of the whole world.'" [Chrys. Matt. xxvi. lxxxii.] The word is constantly translated "offer" and "sacrifice," and by equivalent terms in the English version of the Old Testament, and it clearly has that meaning in Luke ii. 27. It would therefore be watering down the sense of it in this place if any less meaning were to be assigned to it as all the meaning that it contained². (3) The expression "in remembrance of Me" [*εἰς τὴν ἐμὴν ἀνάμνησιν*] is also of a sacrificial character, meaning, in conjunction with the preceding, "Offer this as a Memorial of Me before the Father." So the word *μνημόσυνον* is used in Leviticus ii. 2. 9, "the priest shall burn the memorial of it upon the altar," and *ἀνάμνησιν* itself in Numbers x. 10 and Leviticus xxiv. 7, "and when so applied," says Mr. Keble, it "means always 'a portion of something offered to Almighty God, to remind Him' of the worshipper himself, or of some other person or object in whom the worshipper takes an interest; or of His own loving-kindness, shown by mercies past or gracious promises for the future." . . . "This is the proper drift of the word *remembrance* in our Lord's institution of the Sacrament. 'Do this;' He seems to say,

¹ The same word is used in John vi. 11, where our Lord "eucharistized" the five loaves before putting them into the hands of His disciples with the new capacity of feeding five thousand men. The whole action of this miracle has an Eucharistic character. [See note at p. 95, on the Gospel for Mid-Lent Sunday.]

² See Carter on the Priesthood, p. 84, note. Cf. Lev. ix. 7, in LXX. Isa xix. 21. 1 Kings xi. 33. And see Bp. Salisbury's Charge, 1867, p. 165—168. X

Bless, break, distribute, receive this Bread; bless, distribute, drink of this Cup; say over the two respectively, This is My Body, This is My Blood, in order to that Memorial Sacrifice which properly belongs to Me; the Memorial which My servants are continually to make of Me, among one another, and before My Father¹. This term also is used twice in St. Paul's account of the institution. (4) Lastly, St. Paul uses an expression which must be interpreted in a similar manner, when he says, "ye do shew" [καταγγέλλετε] "the Lord's death." That the whole early Church thus understood our Lord's words, applying them to the offering of the Holy Eucharist by His Ministers, and not only to His one oblation of Himself, is shown by the words of the Fathers, by decrees of Councils, and more than all by the constant witness of the ancient Liturgies. Thus, St. Cyprian says, "For if Jesus Christ, our Lord and God, is Himself the great High Priest of God the Father, and first offered Himself a Sacrifice to the Father, and commanded this to be done in remembrance of Himself, surely that priest truly acts in Christ's stead, who imitates that which Christ did; and he then offers a true and full Sacrifice in the Church to God the Father, when he begins to offer it according as he sees Christ Himself offered it." [Cyp. Ep. lxi. 11.] In the fifth Canon of the Nicene Council an injunction is given respecting the appeasing of disputes in Lent that "the Gift may be offered pure to God." In the eleventh Canon one kind of penitents are directed to join in the prayers "without offering;" and in the eighteenth those are spoken of "who offer the Body of Christ²." How distinctly the ancient Church spoke on the subject, in its solemn public language before God, may be seen by the following Prayers of Oblation taken from some of its Liturgies:—

Liturgy of St. James.—We therefore also, sinners, remembering His life-giving Passion, His salutary Cross, His Death and Resurrection from the dead on the third day, His Ascension into Heaven, and Session on the right hand of Thee His God and Father, and His glorious and terrible coming again, when He shall come with glory to judge the quick and the dead, and to render to every man according to his works, offer to Thee, O Lord, this tremendous and unbloody Sacrifice, beseeching Thee that Thou wouldst not deal with us after our sins, nor reward us according to our iniquities; but according to Thy gentleness and ineffable love, passing by and blotting out the handwriting that is against us, Thy suppliants, wouldst grant us Thy heavenly and eternal gifts, which eye hath not seen, nor ear heard, neither hath it entered into the heart of man to conceive the things which Thou, O God, hast prepared for them that love Thee.

Liturgy of St. Clement.—Wherefore having in remembrance . . . we offer to Thee our King and our God, according to this institution, this bread and this cup; giving thanks to Thee through Him, that Thou hast thought us worthy to stand before Thee, and to sacrifice unto Thee.

Liturgy of St. Mark.—[Before Consecration] . . . Our Lord and God and Saviour Jesus Christ, by Whom, rendering thanks to Thee with Himself and the Holy Ghost, we offer to Thee this reasonable and unbloody Sacrifice, which all nations offer to Thee, O Lord, from the rising of the sun unto the going down of the same; from the north and from the south; for Thy name is great among the Gentiles, and in every place incense is offered to Thy name, and a pure offering. [After words of Institution³] O Almighty Lord and Master, King of Heaven, we announcing the death of Thine only-begotten Son our Lord and God and Saviour Jesus Christ . . . O Lord our God, we have set before Thee Thine own of Thine own gifts.

Liturgy of St. Chrysostom.—We therefore, remembering this salutary precept, and all that happened on our behalf, the Cross, the Tomb, the Resurrection on the third day, the Ascension into heaven, the Session on the right hand, the second and glorious coming again, in behalf of all, and for all, we offer Thee

Thine own of Thine own. . . . Moreover we offer unto Thee this reasonable and unbloody Sacrifice: and beseech Thee and pray and supplicate; send down Thy Holy Ghost upon us, and upon these proposed gifts.

Sacramentary of St. Gregory.—Wherefore, O Lord, we Thy servants, and also Thy holy people, having in remembrance Thy Son Jesus Christ our Lord, as well His blessed Passion, as also His Resurrection from the lower parts of the earth [ab Inferis], and His glorious Ascension into Heaven: offer unto Thine excellent Majesty of Thine own donations and gifts which Thou hast given a pure offering [hostiam], an holy offering, an immaculate offering; the holy Bread of eternal life, and the Cup of everlasting salvation.

The last of these is the Prayer of Oblation which was used by the Church of England (in common with the rest of the Western Church) before the translation of her offices into English. In the Prayer Book of 1549, the Prayer was substantially retained, the following words succeeding the words of Institution:—

English Communion Office of 1549.—Wherefore, O Lord and heavenly Father, according to the Institution of Thy dearly beloved Son, our Saviour Jesu Christ, we Thy humble servants do celebrate and make here before Thy Divine Majesty, with these Thy holy gifts, the memorial which Thy Son hath willed us to make: having in remembrance His blessed Passion, mighty Resurrection, and glorious Ascension, rendering unto Thee most hearty thanks for the innumerable benefits procured unto us by the same; entirely desiring Thy fatherly goodness mercifully to accept this our Sacrifice of praise and thanksgiving; most humbly beseeching Thee to grant, that by the merits and death of Thy Son Jesus Christ . . . [as in the present Office].

When the Canon was separated into three parts in 1552, these words of oblation were placed after the Communion and the Lord's Prayer. In the Scottish Office of 1637, a return was made to the Liturgy of 1549; and in the revision of 1661, Bishop Cosin proposed to restore this form rather than that of 1552, as Queen Elizabeth and Lord Burleigh had also wished. But Bishop Cosin's wishes were overruled, probably because it was considered that the times were too dangerous to admit of any conspicuous change in the Communion Service.

Although, however, the change in the position of the words of Oblation has tended to obscure the meaning of the Service, it cannot for a moment be supposed that the revisers of our Liturgy in 1552 were so exceedingly and profanely presumptuous as to wish to suppress the doctrine of the Eucharistic Sacrifice. There were probably some unfortunate temporary reasons (such as the unscrupulous tyranny of ignorant and biassed rulers), which influenced them to make such a change as would save the doctrine, while it left the statement of it more open than before: and they probably thought it better to consult expediency to a certain extent, than to run the risk of such an interference as would have taken the Prayer Book out of the hands of the Church, and moulded it to the meagre faith of Calvinistic Puritans. After the alteration was made, some of our best and holiest Divines, such as Andrewes and Overall, were accustomed to say the "first Thanksgiving," or Prayer of Oblation, before administering the elements, and the second, "Almighty and everliving God," after the Lord's Prayer, but this practice has been discontinued since the last Revision, though its revival is much to be desired.

From the very nature of the Holy Eucharist it is, however, impossible for any such change as that which was thus made to vitiate its sacrificial character. The Act of Consecration is in itself an act of Sacrifice, whether or not it is accompanied by express words of oblation. So long therefore as properly ordained Priests use the proper formula of consecration, there must necessarily be an offering of the Holy Eucharist to God; although such a *minimum* of form is, it is true, quite discordant with the spirit and letter of Apostolic Liturgies. The whole service is also a virtual memorial before God, even if there were not in any part of it specific words on the subject.

But the Prayer of Oblation yet remains in our Liturgy, though displaced from its ancient position, and said after Communion;

¹ Euch. Ador. p. 68.

² Routh's Script. Eccl. i. 373. 377. 381.

³ It must be remembered that the Oriental Church believes the consecration to be incomplete without an Invocation of the Holy Ghost, as well as the words of Institution.

and while any portion of the consecrated elements remain upon the altar (even after a portion has been consumed), the ancient Sacrificial Act of the Church is literally and verbally continued in respect to that portion: supposing that it is not sufficiently continued towards the portion previously consumed by the more general form of the Prayer of Consecration. There need, therefore, be no room for saying that the Eucharistic Sacrifice is not effectively offered by the modern Liturgy of the Church of England; and all that can be truly said is, that a deviation from ancient practice has been made in consuming a part of the consecrated elements before a formal, verbal oblation of them has been made.

The constant language and practice of the Church having thus been shown, it remains to state in a few words what the Eucharistic Sacrifice is, and what its relation to the one "full, perfect, and sufficient sacrifice, oblation, and satisfaction for the sins of the whole world," which was made by our Lord and Saviour upon the cross.

1. The very nature of the rite makes it sufficiently evident that whenever the words of Oblation are used, they apply to that which the elements of Bread and Wine become by the Act of Consecration. An oblation of the Bread and Wine, as such, is made in the Prayer for the Church Militant, and before the Act of Consecration they are spoken of as "these Thy creatures of Bread and Wine," with special reference to this oblation of them as unconsecrated elements, offered to God that He may sanctify them. But after the Act of Consecration they are no longer called Bread and Wine, but the Body and the Blood of our Lord Jesus Christ. What is offered to our heavenly Father in the Holy Communion is the whole substance of the Sacrament, that which (even although the natural bread and wine are not annihilated by Consecration) is reverently called by the name of the Body and Blood of Christ, and by that name alone.

2. This Sacrifice or Oblation is a solemn memorial offered to God the Father "according to His Son our Saviour Jesus Christ's holy institution," of the Sacrifice which was offered upon the cross. There is no new immolation of the Body of Christ, but a re-presentation of that which was once for all accomplished at Calvary, a showing,—*καταγγελία*, or *ἀνάμνησις*, a proclamation or memorial,—of the Lord's death until He come. When we can understand *how* the elements become the Body and Blood of Christ by Consecration, then we may understand in what manner the offering of those consecrated elements to God the Father is a

re-presentation of the Sacrifice of the Cross. But as the fact is a mystery in the one case, so there is a mystery connected with the act in the other; and the very nature of the Sacrament is such as to lead to the belief that these mysteries will not be unveiled to the Church in its Militant condition; but that Faith must still be exercised towards it when Understanding can go no further.

3. The Eucharistic Sacrifice is not the offering of the Celebrant alone, but of the whole Church, and especially of those who are then before the altar where it is being offered. This was made especially clear in the language of the ancient Church of England, which carefully used a plural pronoun even in several places where the singular is used in the Roman Liturgy. But in both the Roman and the English rite the Prayer of Oblation is worded, "We Thy servants, and also Thy holy people offer to Thy Divine Majesty . . ." And in one part of it the Priest is directed to turn to the people and say, "Pray, brethren and sisters, for me that this my sacrifice, which is also equally yours, may be accepted by our Lord God!" In our modern Liturgy this important recognition of the priesthood of the laity is still made by a similar use of plural pronouns, by the "Amen" of the people at the end of the Prayer of Consecration, and by the rubric which directs that when the Priest says the Lord's Prayer after Communion the people are to repeat it as well.

4. It must be remembered that as the anticipatory Sacrifices of the Jewish Church were acceptable to the Father only through Christ, so the memorial Sacrifice of the Christian is also acceptable through Him alone. The Priest on earth does his sacerdotal work as the agent, deputy, and representative of the eternal High Priest from Whom he receives his commission; and the work done by him is efficacious, because it is taken up into the continual intercession of Christ in heaven. So the Sacrifice of the Holy Eucharist is acceptable to the Father because it is associated with the perpetual presentation of Himself which our Intercessor is making for our sakes: because, that is, the Body and Blood of Christ which are offered upon the earthly altar are, in a mystery, the Body and Blood of that "Lamb as it had been slain," which stands in the midst of the throne, and in the midst of the four living creatures, and in the midst of the elders; and Whom all the host of heaven adore as the Lamb Who has redeemed men by His blood out of every kindred, and tongue, and people, and nation.

THE USE OF THE HOLY COMMUNION.

The preceding sections have shown with how great reverence the Church has always regarded the Holy Eucharist, and what grounds there are in the nature of the rite, as a Sacrament and a Sacrifice, why it should be so regarded. The question which naturally follows is, what is the place held by this holy rite in the economy of grace and salvation: that is, independently of What it is,—or rather, following on What it is,—What is its use?

§ *The Divine Presence conferred on the Church by the Holy Eucharist.*

The nature of the Sacrament being what it is, the Divine Presence is associated with it in a special manner on every occasion of its celebration. For where the Body and Blood of Christ are, there is the Human Nature of Christ; and where the Human Nature of Christ is, there is the Divine Nature of Christ. For as that Divine Nature was united to the dead Body of our Lord when it lay in the tomb, preserving it from corruption, and with His soul when it descended into Hell, triumphing by Divine might over Satan and breaking the bonds of those He had ransomed, so much more is that Divine Nature inseparable from His reunited Body and Soul now that they are in a glorified condition. Although, therefore, it would be rash over-definition to allege any thing as to the manner in which our Lord vouchsafes His Divine Presence in and by the holy Sacrament, yet the fact is so clear that it may be almost called self-evident; and no one who believes that the "inward part or thing signified" is

present, can logically withhold his assent from the further conclusion that He Who is "One Christ" is present as God as well as present as Man. And as we believe that the elements of Bread and Wine are by consecration taken up into a higher nature and become the Body and Blood of Christ, so we must believe also that the effectuation of that marvellous mystery effectuates likewise a fulfilment of the gracious promise, "Where two or three are gathered together in My Name, there am I in the midst of them."

Hence a simple faith finds no difficulty in respect to the adoration of our Divine and Human Lord at the time of, and in special association with, His Presence in the Holy Eucharist. Such a faith draws its possessor into close agreement with the spirit of the Liturgy, in which the elements of Bread and Wine pass out of its language after consecration, and only the Body and Blood of Christ are then spoken of. Such a faith looks beyond the means to the end. To it the outward part of the Sacrament is as if it were invisible, for its gaze is absorbed on the inward part. From the material substance it passes onward to the Divine Presence, and without asking Where? or How? it bows down in humble adoration, saying, not so much My God is here, as, I am before my God, even the God Whom Heaven and earth must worship.

¹ The Roman words are "meum ac vestrum sacrificium;" those of all the English uses, "meum pariterque vestrum . . . sacrificium."

§ *The Eucharist a Sacrifice offered for the benefit of the Church.*

As the Holy Communion is the great Oblation or Sacrifice of the Christian Church to memorialize the Father of our Blessed Lord's work, so it is offered with a purpose, which is, to memorialize Him on behalf of the souls whom our Lord's work is saving. Thus it is the great means by which the Church *out of Heaven* participates in that propitiatory Sacrifice of Intercession which is being for ever offered *in Heaven* by our Lord and Saviour.

The habit of thought on this subject in the Primitive Church is very clearly illustrated by the words of St. Cyril of Jerusalem in the fourth century. In describing the rites of the Holy Eucharist to the newly-confirmed he speaks as follows:—"Then, after the spiritual Sacrifice is perfected, the bloodless Service upon that Sacrifice of propitiation, we entreat God for the common peace of the Church; for the tranquillity of the world; for kings; for soldiers and allies; for the sick; for the afflicted; and, in a word, for all who stand in need of succour we all supplicate and offer this Sacrifice. Then we commemorate also those who have fallen asleep before us, first, Patriarchs, Prophets, Apostles, Martyrs, that at their prayers and intervention God would receive our petition. Afterward also on behalf of the holy Fathers and Bishops who have fallen asleep before us; and in a word, of all who in past years have fallen asleep among us, believing that it will be a very great advantage to the souls for whom the supplication is put up, while that holy and most awful Sacrifice is presented" [Catech. Lect. xxiii. 9, 10]. These words exactly represent the tone and custom of the Primitive Liturgies. The following most beautiful prayer is from that of St. James, and was offered up day by day in the Church of Jerusalem, where St. Cyril was one of that holy Apostle's successors. It was said immediately after the Consecration.

Eucharistic Prayer for the Living and the Departed, from the Liturgy of St. James.

That they may be to those that partake of them, for remission of sins, and for eternal life, for sanctification of souls and bodies, for bringing forth good works, for the confirmation of Thy holy Catholic Church, which Thou hast founded upon the rock of faith, that the gates of hell may not prevail against it; freeing it from all heresy and scandals, and from them that work wickedness, and preserving it till the consummation of all things. We offer them also to Thee, O Lord, for Thy holy places which Thou hast glorified by the Divine appearing of Thy Christ, and by the Advent of Thine All-Holy Spirit, especially for the glorious Sion, the mother of all Churches. And for Thy Holy Catholic Apostolic Church throughout the world. Supply it, O Lord, even now, with the plentiful gifts of Thy Holy Ghost. Remember also, O Lord, our holy fathers and brothers in it, and the Bishops that in all the world rightly divide the word of Thy truth. Remember also, O Lord, every city and region, and the Orthodox that dwell in it, that they may inhabit it with peace and safety. Remember, O Lord, Christians that are voyaging, that are journeying, that are in foreign lands, in bonds and in prison, captives, exiles, in mines, and in tortures, and bitter slavery, our fathers and brethren. Remember, Lord, them that are in sickness or travail, them that are vexed of unclean spirits, that they may speedily be healed and rescued by Thee, O God. Remember, Lord, every Christian soul in tribulation and distress, desiring the pity and succour of Thee, O God, and the conversion of the erring. Remember, Lord, our fathers and brethren that labour and minister to us through Thy holy Name. Remember, Lord, all for good; have pity, Lord, on all; be reconciled to all of us; give peace to the multitude of Thy people; dissipate scandals; put an end to wars; stay the rising up of heresies. Give us Thy peace and Thy love, O God our Saviour, the succour of all the ends of the earth. Remember, Lord, the healthfulness of the air, gentle showers, healthy dews, plenteousness of fruits, the crown of the year of Thy goodness, for the eyes of all wait upon Thee, and Thou givest them their meat in due season;

Thou openest Thine hand, and fillest all things living with plenteousness. Remember, Lord, them that bear fruit and do good deeds in Thy holy Churches, and that remember the poor, the widows, the orphans, the stranger, the needy; and all those who have desired us to remember them in our prayers. Furthermore, O Lord, vouchsafe to remember those who have this day brought these oblations to Thy holy Altar; and the things for which each brought them, or which he had in his mind: and those whom we have now commemorated before Thee. Remember also, O Lord, according to the multitude of Thy mercy and pities, me Thy humble and unworthy servant; and the Deacons that surround Thy holy Altar. Grant them blamelessness of life, preserve their ministry spotless, keep in safety their goings for good, that they may find mercy and grace with all Thy Saints that have been pleasing to Thee from one generation to another, since the beginning of the world, our ancestors, and fathers, Patriarchs, Prophets, Apostles, Martyrs, Confessors, Teachers, Holy Persons, and every just spirit made perfect in the faith of Thy Christ. . . Remember, Lord, the God of the spirits and of all flesh, the Orthodox whom we have commemorated, from righteous Abel unto this day. Give them rest there, in the land of the living, in Thy kingdom, in the delight of paradise, in the bosom of Abraham, Isaac, and Jacob, our holy fathers, whence pain, sorrow, and groaning is exiled, where the light of Thy countenance looks down, and always shines. And direct, Lord, O Lord, in peace the ends of our lives, so as to be Christian, and well-pleasing to Thee, and blameless; collecting us under the feet of Thine elect, when Thou wilt, and as Thou wilt, only without shame and offence; through Thine only-begotten Son, our Lord and God and Saviour Jesus Christ; for He alone hath appeared on the earth without sin.

Such commemorations of the living and of the departed are found in all the Liturgies of the Primitive Church; and it is to be observed that they were not only general commemorations, but that the names of persons who were to be prayed for were read out from the Diptychs, folded tables of wood or other material on which they were inscribed. At a later period the names were not so numerous as they had been when the dangers of the living and the martyrdoms of the departed were a part of every-day experience, and they then came to be inserted in the prayer itself, at least in the Western Church.

In our present English Liturgy the commemorations are of a much more general character than they were in these ancient ages of the Church. In the Collect for the Church and Sovereign, and in the Prayer for the Church Militant, the living and the servants of God departed this life in His faith and fear, are still, however, commemorated, as they are also in the prayer for "all Thy whole Church," which is now a Prayer both of Oblation and Thanksgiving; and if the language used is more concise than formerly, it cannot be said to be less comprehensive.

Such intercessory prayer particularizes those for whom the benefit of the Eucharistic Sacrifice is sought, but it is through the Sacrifice itself that the benefit is to be obtained. By it is conveyed to the Church without the gates of Heaven, the blessing of that Sacrifice which is being offered up before the Throne of God within. And as the collected Church prays by the mouth of the celebrating priest at its head, that God will be mercifully pleased to accept its sacrifice of praise and thanksgiving, it also adds "most humbly beseeching Thee to grant that, by the merits and death of Thy Son Jesus Christ, and through faith in His blood," first "we" and secondly "all Thy whole Church" (made up of those that are in Christ here and in the invisible world) "may obtain," first, "remission of our sins," and, secondly, "all other" known and unknown "benefits of His Passion." To such general words each individual may reverently add the mention of his own particular needs, and of those of others for whom he offers up intercession to God. And although in the case of the departed we know not what is the nature of the advantage gained for them by the intercession of the living Church, yet we may well say with St. Chrysostom, "Not unmeaningly have these

things been devised, nor do we in vain make mention of the departed in the course of the divine mysteries, and approach God in their behalf, beseeching the Lamb, Who is before us, Who taketh away the sin of the world; not in vain, but that some refreshment may thereby ensue to them. Not in vain doth 'he that standeth' by the altar cry out, when the tremendous mysteries are being celebrated, 'For all that have fallen asleep in Christ, and for those who perform commemorations in their behalf' For if there were no commemorations for them, these things would not have been spoken, since our service is not mere scenery, God forbid; yea, it is by ordinance of the Spirit that these things are done" [Hom. xii. on 1. Corinth. xv. 46]. We cannot trace all the details of the benefits which are to be gained for the Church at large, and for its individual members, by the Oblation of the most holy Sacrament of Christ's Body and Blood; but we can accept with our reason the general doctrine of the ancient Church on this subject, and with our faith we can make a reverent application of that doctrine to the details of our own necessities and those of others.

Such being the principle of the Eucharistic Sacrifice as regards the benefit to be gained by means of it, there is one further consideration to be named. These benefits are connected with the Sacrament as an Act of Oblation, not as an Act of Communion: and although Communion adds still greater blessing to those who receive it, yet the Communion of one person cannot be of advantage to another, and the benefits referred to must thus be considered as independent of the Act of Communion, so far as the latter is not necessary to complete the Act of Oblation. It would therefore be extremely rash to assert that a person can gain no benefit from being present at the Holy Communion without receiving it. Moreover we may well shrink from saying so, since the Church has never authoritatively asserted that God limits the blessings of the Holy Eucharist to its reception; the practice of the Church teaches her belief that He does not do so; and many saints have been convinced that they themselves had been spiritually gainers even by being devoutly present only at the celebration of the Holy Communion without partaking of it. Although, therefore, certain abuses of this holy Sacrament may associate themselves with a frequent habit of being present without communicating, there is no theological reason for believing it a useless or injurious practice; and whatever legitimate objections there may be to it must rest on their proper ground, that of reverent and pious expediency.

§ *The Eucharist as a means of union with God.*

Among our Lord's words, in His anticipatory exposition of the Holy Eucharist, there is a clear declaration that it is a means of union between the receiver and Himself. "He that eateth My Flesh, and drinketh My Blood, dwelleth, in Me, and I in him." [John vi. 56.] Of these words an interpretation is given in an exhortation of our Communion Office: "The benefit is great, if with a true penitent heart and lively faith we receive that holy Sacrament (for then we spiritually eat the flesh of Christ, and drink His blood; then we dwell in Christ, and Christ in us; we are one with Christ, and Christ with us)."

The union thus spoken of in such solemn tones is not a mental conformity of opinion, sympathy, and will, although these necessarily result from it, but it is a real and actual incorporation of the spiritual portion of man's nature with the Sacramental Body and Blood of Christ, and hence with Christ Himself. Such an incorporation is initiated in Holy Baptism¹, by which the foundation of spiritual life is laid; and it is ever being renewed, strengthened, and perfected in the Holy Communion by which the superstructure of spiritual life is built up in the soul.

Union between God and man is represented in Holy Scripture as the height, length, breadth, and depth of spiritual work in the soul. No reasoning can explain what it means, but neither can any reasoning explain away the statements made by God respecting it, as if they had no meaning. But as in tracing up physical life we pass from one step to another until we are

stopped at the threshold of the Eternal Self-Existence, so as we follow up the phenomena of the spiritual life of our nature, we find them lead us from the outward operation of the Holy Ghost upon it to the indwelling of Christ's Human Nature, and thence to Union with the Divine Nature itself through the Man Christ Jesus. Thus the words of our Lord at the Institution tell us that participation in the elements which have been consecrated by Him, (through the ministration of His word by the priest of the earthly altar,) enables the partaker to receive spiritual food, the Body and Blood of Christ. His previous discourse, in John vi., had declared that by means of that spiritual food, the partaker would dwell in Christ and Christ in him. The Apostle St. Paul speaks of this indwelling as so close an incorporation that we "are members of His body, of His flesh, and of His bones," and his words exactly reflect the sense of our Lord's own when He spoke of Himself as a Vine and of His disciples as branches, and added, "He that abideth in Me, and I in him, the same bringeth forth much fruit: for without Me ye can do nothing." [John vi. 5.] Still going to our Lord's discourses, we find Him declaring, "At that day ye shall know that I am in My Father, and ye in Me, and I in you" [John xiv. 20], words which are again reflected in those of His Apostle St. Peter that we are "partakers of the Divine Nature." [2 Pet. i. 3.]

Thus a continuous chain of Unity is formed between the altar of the Church on earth and the Throne of the Divine glory in Heaven; and by an inscrutable operation of grace the Christian soul is linked into that chain, so that Union with God becomes no metaphor, but an actual fact: and the Holy Communion is not merely a federal bond of love between God and man, but a means of spiritual incorporation through the Human Nature of our Lord Jesus Christ.

§ *The Eucharist as a symbol, and a means, of union among Christians.*

The name "Sacrament" shows that an analogy was soon observed between the Holy Communion and the "Sacramentum," or military oath, by which the secular armies of the Roman Empire were bound together in one body. It was probably given to the Holy Eucharist because the latter was an outward sign of the bond of love in which the soldiers of the Christian army are bound together.

The circumstances under which the Institution took place gave it this character. It was in some now unintelligible connexion with the first administration of the Holy Communion that our Blessed Lord gave the Apostles His great example of humility and love by washing their feet. It was at that time also that He said, "A new commandment I give unto you, that ye love one another; as I have loved you, that ye also love one another. By this shall all men know that ye are My disciples, if ye have love one to another." [John. xiii. 34.] No doubt, then, that the significant rite of a common participation in a sacrifice was a self-evident symbol to the disciples, and would be so to others also, of that love which was so solemnly enjoined upon them at the time; and of that spiritual relation to each other in which they were bound by their Christian profession.

But though the Christian *sacramentum* was a symbol, it was also far more than a symbol. It was a sign, but it was an efficacious sign. And in the particular aspect under which we are now viewing it, we must consider the Holy Communion as not only a symbol and sign of spiritual union between Christians, but also as a means by which that union is effected.

For the true cause of Christian unity is the Presence of Christ: and that Presence is bestowed upon the Christian community by sacramental means and agency. The wills of many may combine together, and combine in a holy manner and for a holy purpose, but it is by the will of Christ pervading the individual members of which the Church is made up that such a combination becomes truly spiritual. Hence unity proceeds, not from the members of the Body mystical binding themselves to each other, but from their being united to their Head. The branches of the Vine have an unity with each other by the Unity which they have with the Stem and Root. Thus it is our Lord's action in

¹ See end of Introduction to Baptismal Offices

the holy Sacrament, cementing and consolidating the collateral union by cementing and consolidating the direct union, which gives real unity to the various members of the Body, and to the various branches of the Vine.

This is a very important consideration in respect to the divisions of Christendom. No two Churches can be really separate from each other if they are really united to their Head. In proportion also as the life of Churches is maintained in vigour by means of the blessed Sacrament, in such proportion must they be drawing near to each other; nearer and nearer as they draw into closer union with Christ. Such a consideration may tend to mitigate the sorrow which is felt at the separation between the orthodox, living churches of Christendom: and to establish a conviction that notwithstanding the want of external signs of unity, there is yet a vital unity underlying apparent separation which is most precious, and the development of which is doubtless the true pathway to a restoration of the outward tokens of charity and intercommunion. Neither individual Christians nor corporate Churches can be really in a condition of spiritual separation when the One Christ is dwelling in each, and each is thus a living branch of the True Vine.

§ *The Eucharist strengthening and refreshing the soul.*

The Gift bestowed in the Holy Communion is the spiritual wine that maketh glad the heart of man, and the Bread of Heaven which strengtheneth man's heart; that food of the spirit respecting which our Lord said, "He that eateth Me, even he shall live by Me." [John vi. 57.] Its effect upon the Christian nature, to those who faithfully receive it, may be said, generally, to be a renewal of spiritual life: a re-invigoration of that nature from spiritual weakness: a continual elevation of it from a lower to a higher sphere of good.

This is effected by the power of Christ's indwelling, i. e. by the greater or less communication of His power according to the measure of the Gift of Himself. Hence the Scriptural language respecting Christ being "formed" in us; the "measure of the stature of Christ" being attained by us; the building up, or "edification," of our Christian nature in Him. For the Body and Blood of Christ are the true recuperative Substance which is represented in the New Testament by the word "Grace;" the

antidote of the Fall; and the germinating nucleus of the restored Life. A careful distinction must, however, be drawn between the action of natural food on the body, and the operation of the holy Sacrament. In the former case the living body assimilates the food, and draws it into its own system and substance and life: but in the latter the higher life is that which is received by the lower, and the process of assimilation is reversed. For he who, eating Christ, lives by Him, is by such sacramental feeding taken up into and transformed by that which he receives: and his whole spiritual nature elevated to a nearer degree of conformity with that of his Lord.

And thus it may be seen that as the Holy Communion is a means for elevating the Life of the spirit by communicating to it Him who said "I am the Life," so also it is the means by which the perceptions or faculties of the spiritual nature are to be elevated and intensified. Christ is the true Wisdom, in Whom dwells all the fulness of knowledge. He is "the Light," and "the Truth:" and as the disciples who walked with Him in faith, when He was on earth were illuminated by Him, so those who faithfully receive Him in the Sacrament of His Body and Blood may look for spiritual illumination, and quick perception of Truth. With Him is the well of Life, and in His Light shall we see light. The power of faith in perceiving the "things that are unseen" will be increased, the capacity of knowledge for grasping them will be developed, and continual approximation will be made to that condition in which we shall no more "see as through a glass darkly," but "face to face."

And as the life of the soul, its faith, and its knowledge are thus to be refreshed and strengthened by the inward part of the holy Sacrament, so the love of God and man is to be developed by the same participation at the Fountain of Divine Love. For, as we love God because He first loved us, so it is by the Presence of Him who showed His love for men by giving up His life for them, that the gift of charity will grow and increase. Thus the cold heart will become warm: thus the relationship of the Christian brotherhood will be carried out in practical life: thus devotion will fix itself upon its Divine object, and the earnestness of worship in the Church Militant will train the heart for the fervour of heavenly adoration.

RITUAL USAGES OF THE ENGLISH LITURGY.

The Holy Communion being an institution of so exalted a character, and bringing both the Celebrant and all other communicants into such solemn proximity to the Person of our Lord, Saviour, and God, the ritual provisions for its celebration have ever been carefully regulated and guarded either by the rules of the written Liturgies, or by the known traditional practice of Churches. The rubrics of our own Office will be considered in detail in their respective places, but it will be convenient to say a few words separately, in this Introduction, by way of sketching out the system on which the Holy Communion is celebrated, as to the place of its celebration, the persons engaged in celebrating it, and one or two other subjects connected with its reverent and profitable administration.

§ *The Altar.*

Although it is possible that in the "breaking of bread from house to house" no special altar was provided, yet it is beyond all doubt that as soon as ever places were altogether set apart for the Divine Worship of the Christian Church, the "Lord's Table" became their most essential feature¹. St. Ignatius, who lived in the Apostolic age itself, says, "In every church there is one altar." [Ad Philipp.] Other, early fathers frequently allude to the Christian altar as an object familiar to Christian sight; and in a detailed description of the Cathedral of Tyre, given by Eusebius in his dedication sermon, he distinctly names the holy

altar [*ἅγιον θυσιαστήριον*] placed in the midst of the apse at the east end of the church. There were, however, distinct names given by early Christian writers to the heathen altar [*βωμὸς*] and the altar of the Church [*θυσιαστήριον*], and while they constantly declare that they had not the former, they as frequently speak of the latter as that on which was offered the Christian Sacrifice [*θυσία*] of the Holy Eucharist.

Altars were made of both stone and wood in the ancient Church. One of wood is preserved in St. Peter's Church at Rome, which has been asserted for many centuries to have been used by the Apostle St. Peter². In the time of St. Augustine wooden altars were in use in African churches, while stone altars existed in some of the churches of Asia. The Council of Epaone [A.D. 517] forbade any altars, except those of stone, by its twenty-sixth Canon; but such a Canon does not show that stone was considered to be absolutely essential, although no doubt there were some strong reasons of reverence for the Canon being passed. William of Malmesbury says that wooden altars were originally in common use in England; and that Wulstan, Bishop of Worcester in the eleventh century, caused all such in his diocese to be changed for altars of stone. They are generally of wood in the Eastern Church.

Of whatever material the altar may have been made, or by whatever name called, it has ever been regarded as the LORD'S Table, because it is the place where the Christian Sacrifice

¹ "Altar" and "Table" are used interchangeably in Holy Scripture; both words being used in reference to Jewish, Christian, and Heathen Altars. See 1 Cor. ix. 13; x. 18—21.

² Perhaps the oldest altar of authentic date is a small portable one of wood covered with silver, which was used by St. Cuthbert, who died A.D. 686. It is preserved in Durham Cathedral Library.

is offered to Him, and whence He bestows the Body and Blood of Christ. And because of the honourable office thus belonging to it, the altar has ever been placed in the most honourable position of the Church, raised high above its floor, and decorated with such splendour as art and skill could give it. The Emperor Constantine gave some rich tapestry for an altar, but whether this was for a covering or for curtains cannot be determined. It is certain, however, that fine linen cloths were used to cover the altar during the time of celebration by the Primitive Church. They are mentioned in the Liturgy of St. Chrysostom¹, by St. Isidore, by Optatus [vi. 95], and by St. Gregory, in whose Sacramentary there is a prayer for the benediction of the Palla Altaris and the Corporis Falla.

The symbolical use of lighted tapers in Divine Service is of Primitive Antiquity². They were especially connected with the two great Sacraments and the reading of the Gospel, symbolizing in both the illumination which the Church derives from the "Light of the world." It is thought by some writers [Kuinel on Acts xx. 8] that the "many lights" in the upper chamber where St. Paul preached at Troas were there in honour of the "breaking of bread." They are mentioned frequently by St. Athanasius [Ad Orthodox. i. p. 946], and in the third of the Apostolical Canons; as also by St. Jerome, who speaks of their being lighted by day, at the reading of the Gospel. [Contra Vigil. iii.] By the Injunctions of Edward VI. [A.D. 1547] it was expressly provided that there should be "two lights upon the high altar before the Sacrament, . . . for the signification that Christ is the very true Light of the world;" and the use of them, lighted or unlighted, has always been retained in our Cathedrals, College and Episcopal Chapels, and some Parish Churches³.

The Altar Cross is also handed down to us from the Primitive Church, in which the book of the Gospels was laid upon the Holy Table, resting against, or surmounted by, a Cross, as the sign of the Son of Man, the Word of God, the Saviour whose sufferings upon the Cross had won the salvation of mankind.

It is only necessary further to notice the Credence Table, which is a reverent adjunct of the Altar for holding the vessels and elements until the time when they are offered up at the first Oblation, in the Prayer for the Church Militant.

§ The Celebrant.

In all acts of Divine Service the officiating priest appears in a twofold capacity. (1) Firstly, he is the representative of the great High Priest, who is the Chief Shepherd and Bishop of our souls, and (2) secondly, he is the leader of the people in their adorations and devotions. A little careful reflection will show to which of these two divisions of the MINISTER'S office particular parts of his duties in Divine Service principally belong; and as regards the celebration of the Holy Communion, it will be observed that except when teaching in the Sermon, reading Holy Scripture in the Epistle and Gospel, speaking the words of pardon in the Absolution, or of blessing in the Benediction, the Ministerial work of the Celebrant is that of offering to God the prayers, the alms and oblations, and the "Sacrifice of praise and thanksgiving" (or Eucharist), on behalf of, and at the head of his people. The Church comes together in its corporate capacity (by whatever number it may be represented), as "a spiritual house, an holy priesthood, to offer up spiritual sacrifices acceptable to God by Jesus Christ." [1 Pet. ii. 5.] The Minister who stands at the altar, stands there on behalf of the people, and as their leader, to represent them before God, and to offer up in their name the spiritual sacrifices which they have come together to offer.

These principles lie at the root of all the regulations which are

made by the Church as to the *dress* and the *position* of the Celebrant, and of those who attend upon him. It is of infinitely small importance, *in itself*, what costume the officiating minister wears, or in what particular place he stands; but when the inner meaning and reality of his work, and of his relation to God and the people, are taken into account, we at once see that only shallow thinkers, superficial observers, or persons indifferent to the truth or falsehood of outward appearances, can imagine that these things which are of small importance in themselves continue to be so when they are connected with a mystery so full of meaning, and a Sacrament so full of life and reality as that of the Holy Communion.

α] The dress of the Celebrant.

The general principles by which the ritual costume of the Clergy in the Church of England is regulated will be found set forth in detail in the third section of the Ritual Introduction to this volume, p. lxxv and sqq. Applying these general principles to the particular case of the Holy Communion, we find a particular rubric of 1549, which defines the usage of the Church of England as follows:—"¶ Upon the day, and at the time appointed for the ministration of the Holy Communion, the Priest that shall execute the holy ministry⁴, shall put upon him the vesture appointed for that ministration, that is to say, a white albe plain, with a vestment or cope."

It is clear, therefore, that the ancient tradition of the Church of England was retained and confirmed; and that the existing authoritative law, interpreted by the "Interpretation clause" inserted before Morning Prayer, enjoins the Celebrant to wear the following dress:—

Over his cassock, or long ecclesiastical coat, he is to put on (1) a *linen albe*, i. e., a white robe of a more compact and close-fitting character than a surplice, suitable for wearing under another vestment, and not as the one chiefly in view such as the surplice is. (2) Over the albe, as over the surplice, is to be worn the *stole*, a narrow strip of silk passed across the neck like a yoke, or scarf, and long, enough for the ends to reach a little below the knee. (3) Over the stole is to be worn the *chasuble*, called especially the "*Vestment*," because it is the characteristic Eucharistic robe of all Christendom, and has been so from the earliest age of the Church. The form of the chasuble is that of a short cloak, reaching nearly to the knees, and gathered up by the arms at each side, so as to hang in an oval form before and behind. This vestment is usually made of silk, and its colour (as also that of the stole) varies at different seasons according to rules shown at p. lxxix. But it has often been made of materials more humble or more costly than silk, according as much or little could be expended upon the Service of the Lord's House and Table⁵. [For further detail see the General Appendix.]

β] The position of the Celebrant.

It would appear, at first sight, that nothing could be easier than to determine what should be the position of the Celebrant during his ministration at the Lord's Table, yet it has been the subject of protracted controversy; and volumes full of ponderous

⁴ Cf. *Executor officii*, p. 1, margin.

⁵ During the last and the preceding century the Cope seems to have been substituted for the Chasuble in celebrating the Holy Communion. It was so used in Durham Cathedral until towards the close of the eighteenth century, being first discontinued by Bishop Warburton, when Prebendary of Durham, through irritable impatience of some collision between his wig and the collar of the cope. This use of the cope is expressly enjoined by the 24th Canon, and many proofs exist that the Canon has only been disregarded in comparatively recent times. Vast numbers of copes were destroyed during the persecution and spoliation of the Church in the great Rebellion, but many were preserved, as were those of Peterborough [Kennett's Register, 188] and other Cathedral Churches. Either the cope was thus substituted for the Chasuble because many of the former being used, more of them escaped destruction than of the latter; or else the name of cope was given to the chasuble itself, which seems not improbable, as the form of the two in England was very similar. The Bishops of Queen Elizabeth's reign, in their interpretation of her injunctions, ordered "that there be used only one apparel; as the cope in the ministration of the Lord's Supper, and the surplice in all other ministrations." Cardw. Eocum. Ann. i. 205.

¹ Under the name ελλητόν.

² See Introduction to Baptismal Offices, § *Baptism in the sixth century*.

³ The Altar Lights and all other *ornamenta* not actually used in the celebration of the Holy Communion, should be placed on a retable behind the Holy Table, and rising about eight inches above its surface.

learning were published on the subject by Archbishop Williams and Dr. Peter Heylyn, in the seventeenth century. The cause of all doubt on the subject was the introduction of a ritual phrase, "the north-side of the Table," in 1552, which had not been previously used by the Church of England¹.

The principles stated in a preceding paragraph make it clear that the most natural and common-sense position for the leader of the congregation, when the "Sacrifice of praise and thanksgiving" is being offered at the Altar, is in the front of the Holy Table where his special work is to be done, and where he manifestly stands at their head as an officer stands at the head of his soldiers, when he is leading them forward. Probably no one who held orthodox doctrine respecting the Holy Communion would ever have thought of any other position but for the introduction of the words "north-side," and the practice of the Puritans; which latter was regulated by the unorthodox theory that the Minister was one at the head of a table entertaining guests seated around it.

This shockingly irreverent theory of the Puritans led to the constant removal of the Holy Table into the body of the Chancel or Church by them, without any regard to the supposed necessity on account of which such a removal was permitted in extreme cases by the rubric² [see note at p. 165].

Until this removal became so common a habit, the universal position for the Celebrant was in front of the Altar [fig. 1]; and when the removal took place, the relative position of the Table and the Celebrant remained the same, although the former was placed "table-wise," or with its long sides parallel to the north and south walls of the Church [fig. 2]. When, again, the Holy Table was returned to its ancient place at the east end, and set altar-wise, many of the Clergy retained the position with reference to the congregation, though not with reference to the Table, which they had held when the latter stood table-wise in the Church [fig. 3].

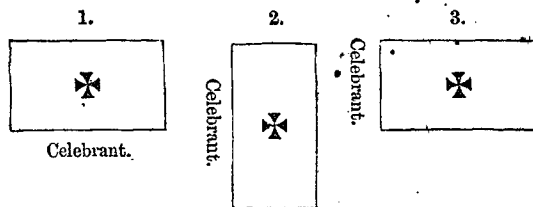

Hence it came to be supposed that "at the north-side of the Table" meant at the part occupied by the Celebrant in the third figure, whereas it was nothing but a ritual synonym for the ancient rubrical expression "*in dextro cornu altaris*" of the ancient Latin Communion Office of the Church of England: the *dexter* corner being that which would be so called in heraldic language, i. e., with reference to that of which it was a part, and not to the right and left hand of the spectator. Thus in the ancient ritual of the Church of England the Altar was ritually divided into three parts:—

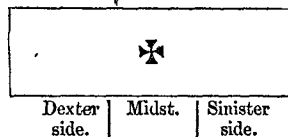

Each of these is mentioned in the following rubric of the Sarum Missal:—" *Sciendum est autem quod quicquid a sacerdote dicitur ante epistolam in dextro cornu altaris expletur: præter in-ceptionem Gloria in excelsis. Similiter fiat post perceptionem Sacramenti. Cætera omnia in medio altaris expleantur, nisi*

¹ The expression is found in the Syriac *Ordo Communis* of the Liturgy; and also [see Neale's East. Ch. ii. 589] in the Mozarabic Liturgy.

² So general had this practice become, that in 1628 Bishop Cosin (then Prebendary of Durham) was accused of being "the first man that caused the Communion Table in the church of Durham to be removed and set altar-wise." Cosin's Works, i. xxix

*forte diaconus defuerit. Tunc enim in sinistro cornu Altaris legatur evangelium*³.

In the ministration of the Holy Communion, then, the Celebrant is clearly to go at once to the front of the Altar, and to say the Lord's Prayer and the Collect for Purity at the "north-side," "dexter-side," or "Gospel-side" of it. In reading the Commandments he stands in the same place "turning to the people," having previously been turning to the altar. The Commandments ended, he returns to his former position, and says the Collect for the Queen and that for the day, "standing as before." After the Gospel he goes to the midst of the Altar, remaining there during all the rest of the Service except at the time of the Sermon and the Communion: turning towards the people when he is acting in his capacity as the minister of God to them: turning towards the Altar when he is acting in his capacity as their Minister, by offering up prayers, praises, alms, oblations, and the Holy Sacrament itself on their behalf to God⁴.

Thus the rubrical position of the chief Minister (the *Ἀρχιερεὺς*, as he is called in the Clementine Liturgy) is in itself highly significant of the work which he is appointed to do in the Holy Communion, and scarcely less significant of that participation of the Laity in the sacred office which he exercises as a leader at the head of those whose privilege it is to be "a royal priesthood." A reverent mind will also see in this relation between the Celebrant and the lay offerers a type of the relation between them and that High Priest Who is the First-born among many brethren, Who has gone up into the Holy of Holies, and Who has entered within the veil to offer up the continual Sacrifice of His once suffering but now glorified Body before the Throne of Grace.

γ] *The Ministers, or Deacon and Sub-deacon.*

The original name for those who assist the Celebrant at the celebration of the Holy Communion was doubtless the general one of Deacon or Minister. When Sub-deacons were appointed they were permitted to read the Epistle, and to wait upon the Deacon, as the Deacon did upon the Celebrant. In the Church of England the rites are comparatively few, and these attending Clergy came often to be called by names characteristic of the most conspicuous part of their duties, the Gospeller and Epistler. So the 24th Canon speaks of them:—

"In all Cathedral and Collegiate Churches the holy Communion shall be administered upon principal feast-days, sometimes by the Bishop, if he be present, and sometimes by the Dean, and at sometimes by a Canon or Prebendary, the Principal Minister using a decent Cope, and being assisted with the Gospeller and Epistler agreeably according to the Advertisements published Anno 7. Eliz. . . ."

So also they are spoken of by Bishop Cosin in the rubric proposed by him instead of that now standing before the Nicene Creed, and which is printed at p. 168 in the foot-notes.

The rubric of 1549, which defines the dress of the Celebrant, defines also that of his assisting clergy: " *And where there be many Priests or Deacons, there so many shall be ready to help the priest in the ministration as shall be requisite; and shall have upon them likewise the vestures appointed for their ministry, that is to say, albes with tunicles.*" The tunicle or tunic is a loose coat with hanging sleeves, to be made of the same material and colour as the chasuble of the Celebrant [see p. lxxix and General Appendix]. That of the Deacon or Gospeller is called in the old rubrics a Dalmatic.

The ordinary places for the assistants of the Celebrant are on the steps of the Altar, behind him, and on either side, the Sub-deacon or Epistler reading the Epistle from his place, two steps below the footpace of the Altar on the south side, and the Deacon or Gospeller from his, which is one step below the footpace on the

³ It may be mentioned that "*Iatus Altaris*" is the equivalent in the Roman Missal for the "*cornu Altaris*" of that of Salisbury.

⁴ Objections are sometimes raised against the Celebrant's "turning his back to the people," as if it were a gesture that is disrespectful to them. The objection is too vulgar and puerile to need more than a notice that it has not been overlooked.

north side. Into further details of their ministrations at the Holy Communion it is unnecessary to enter¹.

§ *The hour for the Celebration of the Holy Communion.*

In the early and unsettled age of the Church, there was no restriction as to the hours during which it was proper to have public celebrations of the Holy Communion. As Christian worship (which consisted almost entirely of this rite) was offered up in the upper chambers of dwelling-houses, or in the "caves and dens of the earth," which were to be found in such places as the catacombs, because it was impossible to do so otherwise than in secret, even so it was offered up at such times as the necessities of Christians demanded, by day or night; and generally, no doubt, during the hours of darkness. So, in the Apostolic period, Pliny wrote to Trajan that the Christians held their assemblies before daybreak; and Tertullian, a century later, gives the true force to the heathen writer's testimony when he says, "The Sacrament of the Eucharist commanded by our Lord at the time of Supper, and to all, we receive even at our meetings before daybreak." [De Coron. iii.] St. Cyprian, in his sixty-third epistle, written A.D. 253, gives a reason why the Holy Communion was celebrated by the Church in the morning, although instituted by our Lord at night. "It behoved Christ," he says, "to offer at the evening of the day, that the very hour of the Sacrifice might intimate the setting and evening of the world, as it is written in Exodus, 'And the whole assembly of the congregation of Israel shall kill it in the evening.' And again in the Psalms, 'Let the lifting up of my hands be an Evening Sacrifice.' But we celebrate the resurrection of the Lord in the morning." [Ep. lxiii. 13.] St. Augustine was consulted as to an evening celebration on the fifth day in Holy Week, that is, Maundy Thursday, and he very distinctly speaks of the general practice of the Church at all times as that of morning celebrations, giving a similar reason to that given by St. Cyprian; but he permits an evening celebration on that day for the Communion of those who could continue their fast so long, as well as the morning one for those who could not. [Ep. cxviii. ad Januar.] Precisely the same rule is laid down by the third Council of Carthage [A.D. 397], which ordained in its twenty-ninth Canon, "that the Sacrament of the Altar is not to be celebrated but by fasting men, the one anniversary day being excepted, on which was instituted the Supper of the Lord; for if commendation is to be made of any departed, whether of bishops, or of clergy, or of others, after noon, let it be done with prayers only, if they who make it shall already be found to have dined."

Many later testimonies might be added, showing that the

¹ The following rubric of the Sarum Communion Office contains so much that is of illustrative value, that it is printed without abbreviation:—

"His finitis, et Officio missæ inchoato, cum post Officium Gloria Patri incipitur, tunc accedant ministri ad Altare ordinatim, primo ceroferrarii duo pariter incidentes, deinde thuribularii, post subdiaconus, exinde diaconus, post eum sacerdos; diacono et subdiacono casulis indutis, scilicet quotidie per Adventum et a Septuagesima usque ad Cœnam Domini, quando de temporali dicitur missa, nisi in vigiliis et Quatuor temporibus, manus tamen ad modum sacerdotis non habentibus; cæteris vero ministris, scilicet ceroferrariis, thuribulariis et acolyto, in albis cum amictibus existentibus. In aliis vero temporibus anni, quando de temporali dicitur missa, et in festis sanctorum totius anni, utantur diaconus et subdiaconus dalmaticis et tunicis, nisi in vigiliis et Quatuor temporibus, et nisi in vigilia Paschæ et Pentecostes, et Nativitatis Domini, si in Dominica contigerit, et excepto jejuniis Quatuor temporum quod celebratur in hebdomada Pentecostes; tunc dalmaticis et tunicis indui debent. In die Parasceves et in Rogationibus ad missam jejunii et processions et in missis dominicalibus et sanctorum quæ in capitulo dicuntur; tunc enim albis cum amictibus utantur; ita tamen quod in tempore Paschali de quocunque dicitur missa, nisi in Inventionem sanctæ crucis, utantur ministri altaris vestimentis albis ad missam. Similiter fiat in festo Annunciationis Beatæ Mariæ, et in Conceptione ejusdem, et in utroque festo sancti Michaelis et in festo sancti Johannis apostoli in hebdomada Nativitatis Domini et per octavas et in octavis Assumptionis et Nativitatis beatæ Mariæ et in commemorationibus ejusdem per totum annum et per octavas et in octavis Dedicationis ecclesiæ. Rubris vero utantur vestimentis omnibus Dominicis per annum extra tempus Paschæ, quando de Dominica agitur, et in quarta feria in Capite jejunii et in Cena Domini et in utroque festo sanctæ Crucis, in quolibet festo martyrum apostolorum et evangelistarum extra tempus Paschæ. In omnibus autem festis unius confessoris vel plurimorum confessorum, utantur vestimentis crocei coloris."

practice of the Church was always to celebrate the Holy Communion early, in the day, and at the least before the principal meal was eaten. Some early writers appear even to enjoin the rule observed in later times, that it should be celebrated and received before any food whatever had been taken on that day².

Another established rule of the later Church is, that the Holy Communion should not be celebrated until after some other Office has been said. "Potest colligi," says Lyndwood [iii. 23], "quod in festo Natalis Domini celebratur primam Missam, quæ solet cantari ante Laudes, debet prius perficere Matutinas et Primam."

The same rule is to be found in the decrees of several diocesan synods of the Church of England, as, e.g., in that of Norwich [A.D. 1257], which ordered "quod nullus sacerdos celebret, quousque Prima canonicè sit completa."

The ancient hour appears to be indicated by St. Gregory of Tours, when he writes, in the life of St. Nicetius, "Hora tertia cum populus ad Missarum solemniam conveniret." The same hour is named by St. Gregory the Great, in his thirty-seventh homily on the Gospels, where he speaks of a bishop who "oblaturus sacrificium ad horam tertiam venerat." This hour is found appointed in the rules of some religious communities [Maskell, Anc. Lit. 154], and was observed in the Cathedral of Durham, of which Davies writes, "At nine of the clock ther rung a bell to masse, called the Chapter masse," [Davies' Rites of Durham, 82.] That nine o'clock in the morning in mediæval times represented a later hour of the day than it does in the present age is evident; yet it is clear, beyond all doubt, that it has been the constant rule of the Church of England to celebrate the Holy Communion before the middle of the day, and after Mattins.

§ *The frequency with which the Holy Communion should be celebrated.*

In the first fervour and joy of their Pentecostal life the disciples of our Lord "continued daily with one accord in the Temple" observing the hours of prayer, and daily also celebrated the Holy Communion in one or other of their private assembling-places, "breaking bread from house to house." [Acts ii. 46.] Holy Scripture gives us no further indication whether a daily Communion became the established habit of the Church; but it seems to have been so invariable a feature of primitive Christian worship that there is hardly any room to doubt its having become so. It must have been such a habit which led the early Fathers to write as they did of the "daily bread" in the Lord's Prayer, meaning the Gift bestowed in the Holy Eucharist; calling it the "super-substantial Bread" with St. Cyril of Jerusalem [Catech. Lect. xxiii. 15], or, with Tertullian, the "Bread which is the Word of the living God which cometh down from Heaven." [De Orat. vi.] St. Cyprian speaks of it in direct terms as a familiar habit of the Church of his day, "... It will be the especial honour and glory of our Episcopate to have given peace to Martyrs; so that we who, as priests, daily celebrate the Sacrifices of God, shall prepare victims for God as well as oblations." [Ep. lvii. 2, "hostias Deo et victimas præparemus."] The same writer also says, "This Bread we pray that it be given us day by day, lest we who are in Christ, and who daily receive the Eucharist for food of salvation, should by the admission of any

² So St. Augustine in the Epistle to Januarius, previously quoted, writes as follows:—"It plainly appears that when the disciples first received the Lord's Body and Blood, they did not receive it fasting. Ought it then to be a matter of reproach to the Catholic Church that this Sacrament has ever been received fasting? For it seemed good to the Holy Ghost that for the honour of so great a Sacrament, the Lord's Body and Blood should enter the Christian's mouth before other food. Since it is for this reason that such a custom is kept throughout the world. And though the Lord gave It after meat, yet the brethren ought not to assemble to receive that Sacrament after dinner or supper, nor mix It up with their meals, as they did whom St. Paul reproves and corrects. For the Saviour, in order more earnestly to recommend the depth of that Mystery, wished, as He was going away from His disciples to His Passion, to fix It in their hearts as His last act. And He left no directions as to the future order, that He might reserve It for the Apostles to do, to whom He was about to commit the Churches. For had He commanded that It should be always received after other food, no one, I believe, would have altered that custom."

grievous crime . . .” [De Orat. Dom. xiii.] The words of St. Augustine show, however, that there was not one rigid and uniform rule on this subject, for he says, “The Sacrament of this thing, that is, of the unity of the Body and Blood of Christ, in some places every day, in some places at certain intervals of days, is on the Lord’s Table prepared, and from the Lord’s Table is taken.” [In Joan. vi. 54.] He also writes elsewhere, “I neither praise nor blame those who receive the Holy Communion daily, but I exhort all to receive it on the Lord’s Days.”

In the ancient Lectionary of St. Jerome, and in the Sacramentaries, provision is made for celebrations on every day at the more sacred seasons of the year; and, in general, on Wednesdays and Fridays at other times; and this also is the case with the Salisbury Missal, which during a large part of the year has Epistles, Gospels, &c., for several or all of the week-days. But no canon of the Church of England exists imposing daily celebration as a rule on the English clergy, although the rule as to Sunday was strict and definite. Nevertheless, it is certain, that daily celebration was the practice of the Clergy; and probably few if any exceptions can be proved in mediæval times.

In the Prayer Book of 1549 provision was made for daily public celebrations, in a rubric before the first Exhortation, as follows:—“¶ *In cathedral churches, or other places where there is daily Communion, it shall be sufficient to read this Exhortation above written once in a month. And in parish churches, upon the week-days, it may be left unsaid.*” The Post-communion sentences were also directed “*to be said or sung, every day one, after the Holy Communion,*” and in the end of the Service is a rubric permitting the omission of the Gloria in Excelsis, the Creed, the Homily, and the Exhortation, “*when the Holy Communion is celebrate on the work-day.*” One of the final rubrics also directs that after the Litany has been said on Wednesdays and Fridays, preparation shall be made to celebrate the Holy Communion, “*the Priest shall put upon him a plain albe or surplice, with a cope, and say all things at the altar*

(appointed to be said at the celebration of the Lord’s Supper), until after the Offertory,” when, if there were no Communicants, he was to dismiss the people with a Collect and “*the accustomed blessing.*” “*And the same order shall be used,*” it is added, “*all other days whensoever the people be customably assembled to pray in the church, and none disposed to communicate with the Priest.*” These rules were, in 1552, condensed into the rubric, which (with the word “*Colleges*” added) now stands at the end of the Service: “*And in cathedral and collegiate churches, where be many Priests and Deacons, they shall all receive the Communion with the Minister every Sunday at the least, except they have a reasonable cause to the contrary.*” The rubrics respecting Collects, Epistles, and Gospels, and Proper Prefaces, will show that provision is made for the celebration of the Holy Communion on any day of the week, and that, at least at certain solemn seasons, such frequent celebrations are plainly contemplated. After the great Rebellion frequent Communion were urged by all our pious Divines, Sparrow, Jeremy Taylor, and Beveridge advocating its daily celebration. Dean Grenville of Durham used most energetic endeavours, under the sanction of Archbishop Sancroft, to get the weekly celebration properly restored in all cathedrals, and, happily, there have been few in which the habit has since been dropped.

The conclusion to be drawn from these evidences of the rule and practice of the Church of England is, that while regular Sunday celebrations of the Holy Communion are the undoubted rule for every Church, provision is also made for more frequent, and even daily celebrations in cathedral churches, and wherever reasons of pious expediency make them desirable. The object of every celebration being twofold, first, an offering of the Holy Eucharist; and, secondly, a Communion, the frequency of them between Sunday and Sunday can never, in the abstract, be without justification; and may, in particular circumstances, become a great spiritual necessity and privilege, to the Church at large, to a particular parish, and to individual Communicants.

THE ORDER FOR THE
ADMINISTRATION OF THE LORD'S SUPPER,
OR
HOLY COMMUNION

[Salisbury Use.
ORDINARIUM of
CANON 2188.E.]

¶ *So many as intend to be partakers of the holy Communion shall signify their names to the Curate, at least some time the day before.*

¶ *And if any of those be an open and notorious*

evil liver, or have done any wrong to his neighbours by word or deed, so that the Congregation be thereby offended; the Curate, having knowledge thereof, shall call him and advertise him, that in any wise he pre-

THE TITLE.

The Order for the Administration] The Title of this Office in the Prayer Book of 1549 was, "The Supper of the Lord, and the Holy Communion, commonly called the Mass." It is evident that the Reformers did not see any reason why this Sacrament should not still be commonly called "The Mass," but the name soon dropped out of use after the introduction of the vernacular into Divine Service, and it was not printed as a third title in 1552, or in any subsequent Prayer Books.

the Lord's Supper] As the name "Mass" was used after the introduction of the reformed Office, so that of "Lord's Supper" was used before, it being found in the "Mirror of our Lady" which was printed in 1530, and in Daye's translation of Hermann's Consultation, which was first printed in 1547. The term is borrowed from 1 Cor. xi. 21, where St. Paul applies it to the Agapæ or love-feasts which then accompanied the celebration of the Holy Eucharist¹. How the singular and inexact use of it which is handed down in our Prayer Book arose, it is difficult to say; and it is a transference of a Scriptural term from one thing to another which cannot be wholly justified. The name thus given to the holy Sacrament has led many to confuse the Lord's Last Supper² with the institution of the Sacrament itself, which it is expressly said took place "after supper" [Luke xxii. 20], and "when He had supped" [1 Cor. xi. 25].

or Holy Communion] Among other names given to the Eucharist, Cardinal Bona mentions this as an ancient one; and says of the term that it is applied not only to the use of the Sacrament, but also to the sacrifice of it, because without the communion of the Celebrant there is no sacrifice. His words are, ". . . sed quia in ea sit consecratio, et participatio corporis et sanguinis Christi, et ideo sine communione esse non potest." The name is Scriptural in the strictest sense, St. Paul saying, "The Cup of blessing which we bless, is it not the Communion of the Blood of Christ? The bread which we break, is it not the Communion of the Body of Christ?" [1 Cor. x. 16.] St. Paul uses the term not primarily of the fellowship which Christians thus maintain with each other by means of the Sacrament, but

of the fellowship which is thus originated through the communion established between the Head and His members by communication to them of His Body and His Blood in that Sacrament. As our Church has happily consecrated the term Bible by calling the book of the Scriptures the "Holy Bible," so by the prefix "Holy" to the word "Communion" a sacred distinctive title is given to the Sacrament which it designates, expressive of its relation both to God and man.

THE INTRODUCTORY RUBRICS.

at least some time the day before] In the Liturgy of 1549 and 1552 the direction was "overnight, or else in the morning, afore the beginning of Matins, or immediately after." This implies, as Cosin remarks, "a certain distance of time between Morning Prayer and High Service. A rule which is at this time duly observed in York and Chichester, but by negligence of ministers, and carelessness of people, wholly omitted in other places" [Works v. 83]. It also shows the intention of the Church, that Matins should be said before the Celebration of Holy Communion, which is to be inferred likewise from the fact that on Palm Sunday the Proper Second Lesson at Matins is Matt. xxvi., and the Gospel is Matt. xxvii., and on Good Friday the Proper Second Lesson is John xviii., and the Gospel is John xix. This is a very ancient rule of the Church of England; as, e. g., in some constitutions of the Province of Canterbury, A.D. 1322, it is ordered, "Let no parish priest celebrate mass till he hath finished matins, prime, and vespers [terce]." Grindal, in his injunctions as Archbishop of York, in 1571, ordered the Morning Prayer, Litany, and Communion to be said together "without any intermission;" there being, doubtless, some local or temporary reason for his so doing.

And if any] These disciplinary Rubrics formed part of the First Reformed Liturgy of 1549. The English, like the Scottish and Continental Reformers, laid great stress on discipline. The definition of the Church in the Homily for Whitsunday includes among its marks, "The right use of Ecclesiastical Discipline;" and that in the Catechism of 1553, "Brotherly correction and excommunication, or banishing those out of the Church that will not amend their lives." Compare also Art. 33, and Canon 26. The disuse of it amongst ourselves, is due partly to the sturdy individualism and indisposition to submit to authority which is part of our national character, and partly to the fact that no sufficient method was devised of supporting the Curate in the exercise of this part of his duty. It is perhaps, to some extent,

¹ See St. Chrysostom, Hom. xxvii., on this passage.

² Pictures are still the books of the unlearned, and many persons derive their impressions of the Institution of the Eucharist from Leonardo da Vinci's picture of the Last Supper. This picture was painted for the refectory of the Dominican convent of S. Maria delle Grazie at Milan, and was intended to represent, as an appropriate subject for such a place, our Lord's parting meal with His disciples. It is sometimes copied in sculpture (as at Durham Cathedral), or in paintings or painted glass (as at St. Nicholas, Newcastle), and placed over the altar, and thus the error is propagated.

³ Johnson's Canons, ii. 338.

sume not to come to the Lord's Table, until he hath openly declared himself to have truly repented and amended his former naughty life, that the Congregation may thereby be satisfied, which before were offended; and that he hath recompensed the parties, to whom he hath done wrong; or at least declare himself to be in full purpose so to do, as soon as he conveniently may.

Matt. v. 23. vi.
14. xviii. 35.

¶ The same order shall the Curate use with those betwixt whom he perceiveth malice and hatred to reign; not suffering them to be partakers of the Lord's Table, until he know them to be reconciled. And if one of the parties so at variance be content to forgive from the bottom of his heart all that the other hath trespassed against him, and

to make amends for that he himself hath offended; and the other party will not be persuaded to a godly unity, but remain still in his frowardness and malice: the Minister in that case ought to admit the penitent person to the holy Communion, and not him that is obstinate. Provided that every Minister so repelling any, as is specified in this, or the next precedent Paragraph of this Rubrick, shall be obliged to give an account of the same to the Ordinary within fourteen days after at the farthest. And the Ordinary shall proceed against the offending person according to the Canon.

Inserted by
Cosin, in 1661.

¶ The Table, at the Communion-time having a fair white linen cloth upon it, shall stand

practically compensated for by the voluntary abstinence from the Lord's Table of all "open and notorious evil livers."

[the Lord's Table] The word Altar, retained in the Liturgy of 1549, was entirely dropped in the Revision of 1552. The motive was the necessity (1) of disabusing the minds of the people of the gross and superstitious notions with reference to the Eucharistic Sacrifice (amounting to a belief in an actual reiteration of the sacrifice of the Cross), which had gradually grown up during the latter centuries of the mediæval period; and (2) of bringing back into its due prominence the truth (which the denial of the cup, and the usually exclusive communion of the Celebrant, had most grievously obscured), that this holy ordinance is intended to be a means of heavenly communion with Christ by the spiritual feeding on His most precious Body and Blood. The consequence of this, and of some other changes made at the same time in the same direction (such, for instance, as the removal of the Prayer of Oblation from its place immediately after the Consecration, the placing of the Altar—during the century which immediately followed the Reformation—in most instances "table-wise," in the middle of the Chancel or of the Nave, so that the Celebrant standing, as usual, at the middle of the long side, faced south instead of East), has been the partial obscuration of the sacrificial aspect of the Holy Eucharist, and the almost exclusive concentration of popular belief on its communion aspect. Only those ignorant of theology can maintain that there is any contradiction between the two. They are in truth correlative and mutually complementary. The Holy Communion is, (1) A solemn presentation and pleading before Almighty God of the one, only, unique, and absolutely sufficient Sacrifice once and for ever finished upon the Cross, and the earthly counterpart of that perpetual presentation of it, and of Himself, which is made in Heaven by the one and only true Priest, Who "ever liveth to make intercession for us" in His "unchangeable Priesthood," as our "High Priest for ever" [Heb. vii.—x.]. And in this aspect that whereon it is celebrated is rightly called, and in ordinary speaking we do call it, an "Altar" [Heb. xiii. 10]. It is (2) A Feast, after an heavenly and spiritual manner, upon that one Sacrifice so pleaded and presented, i. e., upon the Body and Blood of Christ, and in this aspect the Altar is rightly called a "Table" [1 Cor. x. 16—21], though the word "Altar" is twice used by St. Paul, 1 Cor. ix. 13, and Heb. xiii. 10, in connexion with the "partaking" of it. In Scriptural usage the words are synonymous, i. e., different names for the same thing in different aspects, or as respects different uses of it. See Isa. lxxv. 11. Ezek. xxxiii. 41—xxxix. 17—20; xli. 22; xlv. 15, 16. Mal. i. 7. 12. 1 Cor. x. 16—21. The word "Altar" is still retained throughout in the Form for the Coronation of the Kings and Queens of England in Westminster Abbey [see "Burder's Religious Customs"], and is used throughout the "Office of Institution of Ministers into Parishes or Churches," set forth in the General Convention of the American Branch of the English Church in 1804 and 1808. In the Apos-

tolitic Fathers the word "Table" is never used for "Altar," and in the Ecclesiastical writers of the first three centuries after Christ only once. [See also the Introduction to this office, p. 158.]

It may be added that the term "Communion Table" is not to be found in the Prayer Book, the table being invariably viewed as the Table of the Lord, and not of the Communicants.

[a fair white linen cloth] To understand the force of a law, we must understand the meaning which was given to its words at the time when it was imposed. The application of this rule to these words of the rubric will show us that they mean a beautiful linen cloth, not one that is simply clean. So "fayre" is translated "pulcher, venustus, decorus, bellus," in the Promptorium Parvulorum; and of the seventeen meanings given to this adjective by Johnson, that of *pulcher* only is to be found in the English Bible. Thus the Bible speaks of "fair colours" [Isa. liv. 11], and "fair jewels" [Ezek. xvi. 17, and sqq.], and of One Who is "fairer than the children of men" [Ps. xlv. 3]. Linen which is simply *clean* and white, is called in the Bible "pure and white" [Rev. xv. 6], or "clean and white" [Rev. xix. 14], or "fine linen," the two former adjectives being both renderings of the same word, which is *καθαρόν*, in the original. Hence a "fair white linen cloth" does not mean merely a "plain, clean linen cloth," but a white linen cloth which has been made beautiful for its special purpose by the addition of fitting ornamentation.

Since the invention of "damask" linen, the ornament thus wrought in the course of manufacturing the fabric has been very generally adopted; but plain, undamasked linen may be made much more "fair" by means of embroidery; and common sense will show that the word "white" limits the colour of the "linen cloth," not of its ornamentation.

In recent times a custom has been introduced of spreading a large white cloth over the Lord's Table, in the same manner as an ordinary table is prepared for a meal. This is, however, an innovation introduced into the Church at a time when all such arrangements were left to pew-openers and sextons. The "fair white linen cloth" here ordered, and that with which the Celebrant is directed to cover "what remaineth of the consecrated elements," are the *corporalia* of the ancient rubrics, otherwise called *palla lineæ*; a third being used by custom to cover the middle part of the Altar during the celebration. The object of using such a cloth is not to give the idea of a meal; but to carry out the symbolism of the "linen clothes," in which our Lord's body was wound before it was placed in the sepulchre, and which were found there, laid in exact order, after the Resurrection [John xx. 7]. It is a memorial also of that shining raiment, "exceeding white as snow" [Mark ix. 3], in which His transfigured Body appeared to the three disciples; and it is further observable that fine or white linen is ever represented as the clothing of those who dwell in Heaven.

The custom of the Church is to have the linen cloth two or

in the Body of the Church, or in the Chancel, where Morning and Evening Prayer are appointed to be said. And the Priest

standing at the North-side of the Table shall say the Lord's Prayer, with the Collect following, the people kneeling.

OUR Father, which art in heaven, Hallowed be thy Name. Thy kingdom come. Thy will be done in earth, As it is in heaven. Give us this day our daily bread. And forgive us our trespasses, As we forgive them that trespass against us. And lead us not into temptation; But deliver us from evil. Amen.

The Collect.

Joh xlii. 2.*
1 Kings viii. 39.
Ps. xlii. 21.
H. 2. 10-12.
Matt. xxii. 37.

ALMMIGHTY God, unto whom all hearts be open, all desires known, and from whom no secrets are hid;

PATER noster, qui es in cœlis; ^{Salisbury Use.} sanctificetur nomen tuum: adveniat regnum tuum: fiat voluntas tua, sicut in cœlo, et in terra. Panem nostrum quotidianum da nobis hodie: et dimitte nobis debita nostra, sicut et nos dimittimus debitoribus nostris: et ne nos inducas in tentationem: sed libera nos a malo. Amen.

DEUS cui omne cor patet, et omnis voluntas loquitur, et quem nullum latet secretum; purifica per in-

three inches wider than the ritual *mensa*, i. e., the slab of the table, and sufficiently long to hang down nearly to its base at the north and south ends.

in the Body of the Church, or in the Chancel] The explanation of these words is that it was the custom for the communicants to kneel all at once in the chancel, the clergy carrying the consecrated elements to them as they knelt¹. But the number of communicants was sometimes too large for the chancel to hold all at once, and when moveable altars were substituted for fixed ones, it was permitted under such circumstances to transfer them to the nave, and celebrate there instead of in the chancel. Thus the Archbishops and Bishops, in their "Interpretations" of Queen Elizabeth's Injunctions, direct, "Item. That the table be removed out of the choir into the body of the church, before the chancel door, where either the choir seemeth to be too little, or at great feasts of receivings. And at the end of the Communion to be set up again" [on the high footpace, that is] "according to the Injunctions"² [Cardw. Doc. Ann. i. 205; see also Canon 82]. This practice of removing the Lord's Table from its place led to great irreverence, and to a perverted notion of the holy Sacrament; but it continued in many, perhaps in most churches, until the time of Charles I. Neale writes, "When the sacrament was administered in parish churches, the communion table was usually placed in the middle of the chancel, and the people received round it in their several places thereabout." This was, of course, a very different thing from what the rubric allowed, and the reforming Bishops of Charles I.'s days ordered the Table to be placed at the east end of the chancel only. Neale continues, "It is almost incredible what a ferment the making this alteration at once raised among the common people all over England" [Neale's Hist. of Puritans, ii. 221, ed. 1822].

In Cosin's Durham Book, the whole of this rubric of 1552 is altered into the following form, which is similar to that in the Scottish Prayer Book of 1637:—

The TABLE always standing in the midst at the upper end of the Chancell (or of the Church where a Chancell is wanting), and being at all times covered with a carpet of silk, shall also have at the Communion-time a faire white linnen cloth upon it,

¹ Chancel rails were first ordered by Archbishop Laud, chiefly for the purpose of keeping dogs away from the holy Table. They were forbidden by Parliament in 1641. Where there are Chancel screens, Altar rails are not necessary.

² "They that shall be admitted to the Holy Communion, as soon as they have made their oblation, must go together to that place that shall be appointed unto them, nigh to the altar . . . They then which shall be admitted to the Communion of the Lord's board shall stand in that place, the men in their proper place, and the women in their place, and there they shall give thanks, and pray religiously with the pastor."—Daye's transl. of Hermann's Consult., f. 220, ed. 1547

with patin, chalice, and other decent furniture, meet for the high mysteries there to be celebrated.

the Priest standing at the North-side] This means at the north-side of the Table's front, no other boundary-line of the rectangular *mensa* than that in front being taken account of in directing the ministrations of the Celebrant. This seems always to have been the rule of the English Church, except in such unsettled days as those referred to in the last note. Curtains (sometimes called altar-veils) at the north and south ends, appear to have been always used in England, instead of the baldachin or canopy which surrounds the altars of foreign churches; but solid pillars were substituted for these in the elaborate classical "altar screens" of the seventeenth and eighteenth century. The disuse of the latter seems to require a more general return to the curtains than has yet been made, for the purpose of adding dignity to the Lord's Table. In Durham Cathedral those which were anciently in daily use were of white silk.

THE LORD'S PRAYER.

In the ancient Use of Salisbury the Lord's Prayer formed part of the Introductory Service which was said by the Celebrant before he went up to the Altar, and probably in the Vestry. This seems to have been the practice of the Primitive Church, the third Council of Carthage [A.D. 397] decreeing, "Ut . . . cum altari adstititur semper ad Patrem dirigatur oratio: fuit hoc exemplo Christi, Qui discipulos docens orare, exordium preactionis ad Patrem direxit." The first Prayer Book [A.D. 1549] ordered that "*the Priest, standing humbly afore the midst of the Altar, shall say the Lord's Prayer, with this Collect,*" before the Introit was sung; and probably the custom soon arose of saying it aloud. It is, however, still to be said by the Priest alone, as the history of the Service shows; and as is also indicated by the manner of printing the "Amen," which is not to be repeated by the people, but said, like the rest of the Prayer, by the Priest. The Lord's Prayer is not indicated at all in this place in Merbecke's book, and was not printed at length until the Revision of 1661.

As in all other parts of Divine Service, the Prayer of our Lord is here used with a special object. It is a royal Antiphon of Prayer which supplies the key-note of that which is to follow; and the Celebrant uses it as a prevailing intercession with the Father that he may be found not unworthy in the execution of his special office. With the same intention it should be heard by the people, since the offering to be made in the Holy Eucharist is theirs as much as it is that of their leader who stands at their head in front of God's altar.

THE COLLECT.

This Prayer, which is commonly called the "Collect for

1 John iv. 16, 17.
20.
Luke i. 46, 47.

Cleanse the thoughts of our hearts by the inspiration of thy Holy Spirit, that we may perfectly love thee, and worthily magnify thy holy Name; through Christ our Lord. *Amen.*

fusionem Sancti Spiritus cogitationes cordis nostri; ut Te perfecte diligere, et digne laudare mereamur. Per Christum Dominum nostrum. Amen.

¶ *Then shall the Priest, turning to the people, rehearse distinctly all the TEN COMMANDMENTS; and the people still kneeling shall, after every Commandment, ask God mercy for their transgression thereof for the time past, and grace to keep the same for the time to come, as followeth.*

Minister.

Exod. xx. 1-17.

GOD spake these words, and said; I am the Lord thy God: Thou shalt have none other gods but me.

People.

Lord, have mercy upon us, and incline our hearts to keep this law.

Ps. xxxlii. 22.
1 Kings viii. 57,
58.
Ps. cxix. 111. 36.
34.

Minister.

Thou shalt not make to thyself any graven image, nor the likeness of any thing that is in heaven above, or in the earth beneath, or in the water under the earth. Thou shalt not bow down to them, nor worship them: for I the Lord thy God am a jealous God, and visit the sins of the fathers upon the children, unto the third and fourth generation of them that hate me, and shew mercy unto thousands in them that love me, and keep my commandments.

People.

Lord, have mercy upon us, and incline our hearts to keep this law.

Jer. xxxi. 33.
Heb. viii. 10.

Minister.

Thou shalt not take the Name of the Lord thy God in vain: for the Lord will not hold him guiltless, that taketh his Name in vain.

People.

Lord, have mercy upon us, and incline our hearts to keep this law.

Minister.

Remember that thou keep holy the Sabbath-day. Six days shalt thou labour, and do all that thou hast to do; but the seventh day is the Sabbath of the Lord thy God. In it thou shalt do no manner of work, thou, and thy son, and thy daughter, thy manservant, and thy maid-servant, thy cattle, and the stranger that is within thy gates. For in six days the Lord made heaven and earth, the sea, and all that in them is, and rested the seventh day: wherefore the Lord blessed the seventh day, and hallowed it.

People.

Lord, have mercy upon us, and incline our hearts to keep this law.

Minister.

Honour thy father and thy mother; that thy days may be long in the land, which the Lord thy God giveth thee.

Purity," also formed part of the Introductory Prayers of the Celebrant in the Sarum rite, and is not found in any other of the English Liturgies or in the Roman. It appears again in a "Missa ad invocandum gratiam Spiritus Sancti" at the end of the Sarum Missal, and this Mass is attributed by Muratori [ii. 383] to St. Gregory. It is also found in the Sacramentary of Alcuin, and at the end of the York Litany: so that it is probably a Prayer of the early Church, but preserved almost solely by the Church of England.

The Prayer for Purity now forms, naturally, a part of the public Service, and in making it so, it was doubtless the intention of those who reconstructed our Liturgy to make it a Prayer of the people with the Celebrant, for themselves, as well as his own prayer with reference to his special work of celebration. Standing at the head of his flock, the Priest offers up this preliminary Prayer to God for himself and them, that all may be prepared by His mercy for the solemn rite in which they are about to take their respective parts as Priest and Christian laity.

THE TEN COMMANDMENTS.

turning to the people] Turning from the position in which he stands to pray when he faces the altar, to that in which he exhorts, when he faces the people. In the Scottish Liturgy of 1637, this rubric ended as follows: "The people all the while kneeling, and asking God's mercy for the transgression of every duty therein; either according to the letter, or to the mystical importance of the said Commandment."

The use of the Ten Commandments in the Communion Service is quite peculiar to the English Church. It is probably derived from the custom of reciting and expounding them at certain intervals, which is so frequently enjoined by the ancient Synods and the Bishops of the Church of England. Poullain introduced them (probably in metre) into his jejune Liturgy; but it is most probable that he did so in imitation of the old English custom.

The translation of the Decalogue used here, and in the Catechism, is not that of our present version, but that of the "Great Bible" of 1539-40.

People.

Lord, have mercy upon us, and incline our hearts to keep this law.

Minister.

Thou shalt do no murder.

People.

Lord, have mercy upon us, and incline our hearts to keep this law.

Minister.

Thou shalt not commit adultery.

People.

Lord, have mercy upon us, and incline our hearts to keep this law.

Minister.

Thou shalt not steal.

People.

Lord, have mercy upon us, and incline our hearts to keep this law.

Minister.

Thou shalt not bear false witness against thy neighbour.

People.

Lord, have mercy upon us, and incline our hearts to keep this law.

Minister.

Thou shalt not covet thy neighbour's house, thou shalt not covet thy neighbour's wife, nor his servant, nor his maid, nor his ox, nor his ass, nor any thing that is his.

People.

Lord; have mercy upon us, and write all these thy laws in our hearts, we beseech thee. Luke xviii. 13. Ezek. xxxvi. 27.

¶ Then shall follow one of these two Collects for the Queen, the Priest standing as before, and saying,

Let us pray.

ALMIGHTY God, whose kingdom is everlasting, and power infinite; Have mercy upon the whole Church; and so rule the heart of thy chosen servant *VICTORIA*, our Queen and

Ps. cxlv. 13.
Dan. iv. 34. 35.
Ps. cxxii. 6. cii.
13.
Prov. xxi. 1.
2 Chron. xxxi. 20.

In the American Prayer Book the Commandments are followed by our Lord's Summary of the Decalogue from Matt. xxii. 37-40: the use of which is also allowed instead of that of the Decalogue by the Scottish Liturgy.

The respond after each Commandment is somewhat similar in phraseology to the Prayer which follows them in Poullain's Liturgy. The version used at Glastonbury, and printed at London, in 1552, is as follows: "Seigneur Dieu, pere de misericorde, qui nous as par ton serviteur Moyse donné le decalogue, pour nous instruire en la plaine justice de ta loy: vueilles la tellement imprimer en noz cueurs par ton saint Esprit, qu'en toute nostre vie nous n'ayons autre desir ou plaisir, sinon de te servir et obeir en toute sainteté et justice, par Jesus Christ ton filz. Ainsi soit il!" But this respond is, in reality, a Christian application of the Law in the words of Jeremiah xxxi. 33, and Psalm cxix. 36, and as already made by St. Paul in Hebrews viii. 10. It may be clearly traced in the Vulgate: "Inclinaui cor meum ad faciendas justificationes Tuas . . ." [Ps. cxix. 111]. "Inclina cor meum in testimonia Tua, . . ." [Ibid. 36] ". . . et custodiam illam in toto corde meo" [Ibid. 34].

Before the Commandments were formally introduced into the Communion Office, in 1552, the Collect for Purity was followed by the Introit, as in the ancient Service; and, as in it also, the Introit was followed by the Kyrie Eleison said nine times.

The Kyrie thus said appears to represent the ancient Litany element [the Greek *ectene*] of the Eucharistic Office, and especially when it was sung in an expanded form, as it was on all "double" festivals. At the end of some Missals there are several pages, "De cantu Kyrie Eleison," and these contain nine such expanded forms, *Kyrie* generally beginning the first three lines, *Christe* the second three, and *Kyrie* the third three; all the nine lines ending with "Eleison." Mr. Maskell has referred to these expanded forms of the Kyrie at p. 23 of his Ancient Liturgy of the Church of England, and has printed two of them. Translations of two are also here given from a Missal of 1514 as specimens:—

"Lord, Almighty, Father unbegotten, on us wretched ones have mercy.

¹ L'Ordre des prieres et ministere ecclesiastique . . . et la Confession de Roy de l'Eglise de Glastonbury en Somerset . . . A Londres, 1552.

Lord, Who hast redeemed Thine handiwork, by Thine own Son have mercy.

Lord, Adonai, blot out our sins, and on Thy people have mercy. Christ, the splendour of the Father's glory and the image of His substance, have mercy.

Christ, Who didst save the world at the Father's bidding, have mercy.

Christ, Salvation of men and eternal life of angels, have mercy.

Lord the Spirit, the Paraclete, Bestower of pardon, have mercy.

Lord, Fountain of mercy, sevenfold in grace, have mercy.

Lord, most gracious Pardoner, proceeding from Both, most bounteous Bestower of Spiritual gifts, have mercy.

Lord, the Maker of all creatures, have mercy upon us.

Thou who blottest out our sins, have mercy upon us without ceasing.

Let not Thy handiwork perish; but graciously have mercy upon it.

Christ, the only Son of the Father, born of the Virgin, have mercy upon us.

Thou that by Thy Blood savedst a ruined world from death, have mercy.

Hear the Prayer of those who now cry unto Thee, and in tenderness have mercy.

Gracious Spirit, fill us with Thy grace, have mercy.

Thou who flowest from the Father and the Son continually have mercy upon us.

Holy Trinity, trinal Unity, together to be worshipped,

Loosen the bonds of our sins, redeeming us from death.

Let us all now cry aloud with sweetly-flowing voice, O God, have mercy."

An interesting feature of these expanded forms of the Kyrie is the retention of Greek words, which indicates their Eastern origin, and that the associations connected with them were precious to the Church of England.

COLLECT FOR THE SOVEREIGN.

[the Priest standing as before] That is, at the northern part of the front of the Altar, looking towards the East.

Both these Collects appear to have been composed in 1549, but the second is very similar in its phraseology to the first Collect of

Matt. xxii. 21.
Rom. xiii. 1—6.
1 Pet. ii. 13, 14.
19.
Prov. xxiv. 21.
1 Tim. vi. 14—16.
Rev. iv. 8. v. 13.

Governour, that she (knowing whose minister she is) may above all things seek thy honour and glory: and that we, and all her subjects (duly considering whose authority she hath) may faithfully serve, honour, and humbly obey her, in thee, and for thee, according to thy blessed Word and ordinance, through Jesus Christ our Lord, who with thee and the Holy Ghost liveth and reigneth, ever one God, world without end. *Amen.*

¶ Or,

Ps. xciii. 2.
Prov. xxi. 1.
Rev. xvii. 17.
Ps. lxxviii. 70—72.
Prov. viii. 15, 1.
Ps. cxliv. 12—15.
Deut. xxxiii. 29.
John xvi. 23.

ALMIGHTY and everlasting God, we are taught by thy holy Word, that the hearts of kings are in thy rule and governance, and that thou dost dispose and turn them as it seemeth best to thy godly wisdom: We humbly beseech thee so to dispose and govern the heart of *VICTORIA*

thy Servant, our Queen and Governour, that, in all her thoughts, words, and works, she may ever seek thy honour and glory, and study to preserve thy people committed to her charge, in wealth, peace, and godliness. Grant this, O merciful Father, for thy dear Son's sake, Jesus Christ our Lord. *Amen.*

¶ Then shall be said the Collect of the day. And immediately after the Collect the Priest shall read the Epistle, saying, The Epistle [or, The portion of Scripture appointed for the Epistle] is written in the — Chapter of — beginning at the — Verse. And the Epistle ended, he shall say, Here endeth the Epistle. Then shall be read the Gospel (the people all standing up), saying, The holy Gospel is written in the — Chapter of — beginning at the — Verse. And the Gospel ended, shall be sung or said the Creed following, the people still standing, as before.

the Missa pro Rege given at p. 27, of which the first words are "Deus in cuius manu sunt corda regum." There seems to have been considerable variety in the Missa pro Rege et Regina: and it is possible that these Collects are both of them taken from some ancient sources not yet recognized.

The insertion of this Prayer for the Sovereign may be thus accounted for. The Sovereign was mentioned in the ancient Canon, in that of the first Prayer Book, and in the Prayer for the Church Militant, when that Canon was afterwards broken up into three portions as we now have it. But in the first Prayer Book one of the final rubrics directed that on Wednesdays and Fridays, if there was no celebration, the Communion Service should yet be said as far as the end of the Offertory. When so used, the memorial of the Sovereign in the Canon would not be said, and this Collect was probably inserted to supply the deficiency. It would also be said constantly that those who did not remain to receive (and therefore did not hear the Canon), might still hear, and take part in, a Prayer for the Sovereign and the Church. When the Canon was broken up, and that part of it which now forms the Prayer for the Church Militant was removed to an earlier part of the Office, it was directed to form part of the Offertory even when there is no Celebration: and thus the second memorial forms not only part of the Canon, as in ancient days, but of the Service used when there are no communicants. Temporary reasons connected with the disloyalty of the times had probably some influence in fixing this Collect upon the Church.

Viewing the Ten Kyries preceding as a representative, in some degree, of the primitive Ectene, or Great Collect, the Collect for the Sovereign is not without a certain propriety as to its Liturgical position. One of the petitions in that Eucharistic Litany is, "For our most religious and God-protected Sovereigns, for all the Palace and their Army, let us beseech the Lord. Ky: Lord, have mercy upon us."

It should also be added that "Memoriae" were said with the Collect for the day under the old system of the Church of England, and that the use of the present memorial Collect for the Sovereign may represent an ancient custom. The Rubric was as follows:—"Deinde dicitur oratio, sic determinando, Per omnia secula seculorum. Amen. Et si aliqua Memoria habenda est iterum dicat Sacerdos Oremus ut supra. Et quando sunt plures collectae dicendae, tunc omnes Orationes quae sequuntur sub uno, Per

Dominum, et uno Oremus dicuntur. Ita tamen quod septenarium numerum excedere non debent secundum usum Ecclesiae Sarum."

[the Collect of the day] Some notes on the history of the Collects *de Tempore* will be found at p. 69; some special rules connected with their use at p. 24.

If Memorial Collects, on account of national or diocesan afflictions or necessities, should ever be issued by the authorities of our Church, the proper place to use them is after the Collect or Collects of the day, both here, and at Mattins and Evensong.

[shall read the Epistle] For notes on the history of the Epistle and Gospel as used in the Communion Office, see p. 70. The Epistle was anciently read from a lectern near the Altar, from which sometimes both it and the Gospel also were read. At Durham Cathedral, before its iniquitous spoliation, "at the North End of the High Altar there was a very fine Letter of Brass, where they sang the Epistle and Gospel, with a great Pelican on the height of it finely gilt, billing the blood out of her breast to feed her young ones, and her wings spread abroad, whereon lay the Book, in which they sung the Epistle and Gospel: it was thought to be the finest Letter of Brass in this country!" But this lectern doubtless stood on the north of the Altar because it was used for the Gospel. The proper side from which to say the Epistle is the south.

The following is Cosin's alteration of this rubric in the Durham Prayer Book:—

Immediately after the Collects, the Priest, or the Epistler appointed, shall turn to the people and read the Epistle in the place assigned for it, beginning thus: The Epistle is written in the Chapter of and ending thus: Here endeth the Epistle. And the Epistle ended, the Priest or the Gospeller appointed shall read the Gospel, saying first: The Holy Gospel is written in the Chapter of And the people all standing up shall say: Glory be to Thee, O Lord. And at the end of the Gospel he that readeth it shall say: Here endeth the holy Gospel. And the people shall answer: Thanks be to Thee, O Lord.

Then shall he read the Gospel] The highest reverence has

¹ "Davies' Rites of Durham," written by an eye-witness of the spoliation. There was another brass Lectern in the midst of the Quire for the music-book, and a wooden one for the Lessons lower down, near the Quire door.

(See also Ap. Creed in Mattins and Evensong.)
 Titus i. 9.
 Mark xii. 32.
 Exod. vi. 3.
 1 Cor. viii. 4-6.
 Gen. i. 2.
 Heb. xi. 3.
 John xiii. 13.
 i. 14. 18.
 Ps. ii. 7.
 Col. i. 15. 17.
 Heb. i. 3.
 John ix. 5. xii. 35, 36. xiv. 11.
 x. 30. ii. 3. 9.
 Col. i. 16.
 John iii. 13. vi. 38. i. 14.
 Gal. iv. 4.
 1 Tim. ii. 5.
 1 John iv. 2, 3.
 John xix. 16-18.
 Matt. xx. 28.
 John xix. 38-42.
 1 Cor. xv. 3, 4.
 Ps. cx. 1.
 Col. iii. 1.
 Matt. xvi. 27.
 1 Pet. iv. 5.
 Luke i. 33.
 Rev. xi. 15.
 2 Cor. xiii. 14.
 John vi. 63.
 2 Cor. iii. 6. 17, 18.
 John xv. 26.
 Rev. iv. 8.
 Matt. iv. 10.
 Isa. vi. 3.
 Acts xxviii. 25.
 2 Pet. i. 21.
 Heb. xii. 23.
 Acts ii. 42. 47.
 Eph. iv. 1. 3-6.
 Acts ii. 38. xxii. 16.
 Rev. xx. 12, 13.
 1 Cor. xv. 52, 53.
 2 Pet. iii. 13.
 Heb. ii. 5. vi. 5.
 Rev. i. 7. xxii. 20.

Elihoque.

I BELIEVE in one God the Father Almighty, Maker of heaven and earth, And of all things visible and invisible :

And in one Lord Jesus Christ, the only-begotten Son of God, Begotten of his Father, before all worlds, God of God, Light of Light, Very God of very God, Begotten, not made, Being of one substance with the Father ; By whom all things were made, Who for us men, and for our salvation came down from heaven, And was incarnate by the Holy Ghost of the Virgin Mary, And was made man, And was crucified also for us under Pontius Pilate. He suffered and was buried, And the third day he rose again according to the Scriptures, And ascended into heaven, And sitteth on the right hand of the Father. And he shall come again with glory to judge both the quick and the dead : Whose kingdom shall have no end.

And I believe in the Holy Ghost, The Lord, and Giver of life, Who proceedeth from the Father and the Son, Who with the Father and the Son together is worshipped and glorified, Who spake by the Prophets. And I believe one Catholick and Apostolick Church. I acknowledge one Baptism for the remission of sins, And I look for the Resurrection of the dead, And the life of the world to come. Amen.

ΠΙΣΤΕΥΟΜΕΝ εἰς ἕνα Θεόν, Πατέρα παντοκράτορα, ποιητὴν οὐρανοῦ καὶ γῆς, ὁράτων τε πάντων καὶ ἀοράτων.

Καὶ εἰς ἕνα Κύριον Ἰησοῦν Χριστὸν, τὸν Υἱὸν τοῦ Θεοῦ τὸν μονογενῆ, τὸν ἐκ τοῦ Πατρὸς γεννηθέντα πρὸ πάντων τῶν αἰώνων. [Θεὸν ἐκ Θεοῦ] Φῶς ἐκ Φωτὸς, Θεὸν ἀληθινὸν ἐκ Θεοῦ ἀληθινοῦ· γεννηθέντα, οὐ ποιηθέντα, ὁμοούσιον τῷ Πατρὶ· δι' οὗ τὰ πάντα ἐγένετο· τὸν δι' ἡμᾶς τοὺς ἀνθρώπους, καὶ διὰ τὴν ἡμετέραν σωτηρίαν, κατελθόντα ἐκ τῶν οὐρανῶν, καὶ σαρκωθέντα ἐκ Πνεύματος Ἁγίου, καὶ Μαρίας τῆς παρθένου, καὶ ἐνανθρωπήσαντα· σταυρωθέντα τε ὑπὲρ ἡμῶν ἐπὶ Ποντίου Πιλάτου, καὶ παθόντα, καὶ ταφέντα, καὶ ἀναστάντα τῇ τρίτῃ ἡμέρᾳ κατὰ τὰς γραφάς· καὶ ἀνελθόντα εἰς τοὺς οὐρανοὺς, καὶ καθεζόμενον ἐκ δεξιῶν τοῦ Πατρὸς· καὶ πάλιν ἐρχόμενον μετὰ δόξης κρῖναι ζῶντας καὶ νεκρούς· οὗ τῆς βασιλείας οὐκ ἔσται τέλος.

Καὶ εἰς τὸ Πνεῦμα τὸ Ἅγιον, τὸ Κύριον, καὶ τὸ ζωοποιόν, τὸ ἐκ τοῦ Πατρὸς ἐκπορευόμενον, τὸ σὺν Πατρὶ καὶ Υἱῷ συμπροσκυνούμενον καὶ συνδοξαζόμενον, τὸ λαλῆσαν διὰ τῶν προφητῶν· εἰς μίαν ἁγίαν καθολικὴν καὶ ἀποστολικὴν ἐκκλησίαν ὁμολογοῦμεν ἐν βάπτισμα εἰς ἄφεσιν ἁμαρτιῶν, προσδοκῶμεν ἀνάστασιν νεκρῶν, καὶ ζωὴν τοῦ μέλλοντος αἰῶνος. Ἀμήν.

πιστεύω in the Greek Liturgies.

ἁγίαν not in the Liturgy of St. Mark.

The Salisbury Latin version of the Nicene Creed was as follows :—

“Credo in unum Deum, Patrem omnipotentem, factorem cœli et terræ, visibilium omnium et invisibilium. Et in unum Dominum Jesum Christum, Filium Dei unigenitum, Et ex Patre natum ante omnia sæcula : Deum de Deo, Lumen de Lumine, Deum verum de Deo vero, Genitum non factum, consubstantialem Patri, per quem omnia facta sunt. Qui propter nos homines et propter nostram salutem descendit de cœlis, Et incarnatus est de Spiritu Sancto ex Maria virgine, Et homo factus est.

Salisbury Use.

always been given by the Church to the Eucharistic dispensation of the Gospel : doubtless from a recognition of the solemn association between such an use of it and the Personal WORD of God, Whose message it is. In the Eastern Church the Book of the Gospels is carried in procession to the Altar, this rite being called the Little Entrance, as the procession of the Elements to the Altar is called the Great Entrance. In the Church of England lighted tapers used to be held on either side of the Gospeller while he was reading, and Incense burned, to signify that the Gospel is from Him Who is the Light of the World, and that the reading of it is a memorial offered before God. The versicle, “Glory be to Thee, O Lord,” is also handed down to us from the ancient Church, was printed in the earlier Prayer Books, and has been retained with a firmer hold than most ritual traditions by subsequent generations.

Standing at the Gospel is a custom significant of this reverent instinct of the Church. The historian Sozomen, who wrote in

the fifth century, knew of only one exception to this custom, which was that of the Bishop of Alexandria. St. Chrysostom bids the people “stand with soul and ear erect” when the Gospel is read, and in the Apostolical Constitutions of the fifth century is the direction, “When the Gospels are in reading, let all the Priests and Deacons, and all the people, stand up in great quietness ; for it is written, ‘Be still, and hearken, O Israel.’ and, again, ‘But do thou stand here and listen !’” Upon this custom Hooker writes, “If sheweth a reverend regard to the Son of God above all other messengers, although speaking as from God also. And against Infidels, Jews, Arians, who derogate from the honour of Jesus Christ, such ceremonies are most profitable.”

At the end of the Gospel, the Celebrant moves to the centre of the Altar, to say the Creed. In Merbecke, and in all other Services, the first words of the Creed, “I believe in God the Father,” are assigned to the Priest alone, the Choir and people joining in at the next words.

Crucifixus etiam pro nobis sub Pontio Pilato, passus et sepultus est. Et resurrexit tertia die secundum scripturas, et ascendit in cœlum, sedet ad dexteram Patris, Et iterum venturus est cum gloria iudicare vivos et mortuos, Cujus regni non erit finis. Et in Spiritum Sanctum Dominum et vivificantem, Qui ex Patre Filioque procedit, Qui cum Patre et Filio simul adoratur et conglorificatur, Qui locutus est per prophetas. Et unam sanctam Catholicam et Apostolicam Ecclesiam. Confiteor unum baptisma in remissionem peccatorum, et expecto resurrectionem mortuorum, Et vitam venturi sæculi. Amen."

The following is an interesting English version of the Nicene Creed, taken from our Lady's Mirror. Printed in 1530, it is yet almost exactly identical with that adopted in 1549. There are much older English versions:—

"I byleue in one god y^e father almyghty, maker of heuen and of erthe, and of al thinges vvsyble and inuisyble, and in one lorde iesu cryste, the only begotten sone of god: borne of the father before al worldes. god of god. lyghte of lyghte. very god of very god. bygotten and not made, and of one substance wyth the father. By whome all thynges are made, whiche for us men and women, and for oure helthe cam downe from heuens. And he was incarnate of the holy gooste of the vyrgyn maye, and he is made man. He was crucyfied also for us under ponce pylate, suffered passyon, and was buryed. And he arose the thyrde daye after scripytures, And he ascēded in heuen and sytteth on the fathers ryghte hande. And he shall come agayne with glory to deme the quycke and the deade. Of whose kyngdome shall be none ende. And I byleue in the holy goste, lord and quykn^r. which proceedeth of the father and of the sonne. which is worshiped, and glorified togyther wyth the father and wyth the sonne, whych hathe spoke by the prophetes. And I byleue on holy comon and apostly chirche. I knowlege one bapty^m in remyssyō of synnes. And I abyde the resurreccyon of the deade. And I abyde the lyfe of the worlde to cōme. Amen."

Mirror of our
Lady version,
A. D. 1530.

THE NICENE CREED.

The recitation of the Creed in the public ministratiō of the Holy Eucharist was first introduced by Peter the Fuller, Bishop of Antioch in 471, and adopted by Timotheus Bishop of Constantinople in 511. In the West it was adopted first in Spain, by the Third Council of Toledo in 589, as an antidote to the Arian heresy, with which the Spanish Church had been infected; then in France in the time of Charles the Great, and lastly in the Roman Church under Pope Benedict VIII. in 1014. Originally the Creed seems to have been used only in the instruction of catechumens, and as their profession of faith when baptized; and also as that of Bishops at their ordination¹.

One of the most interesting of the early creeds is that of Cæsarea, because it was adopted by the Council which assembled at Nicæa in 325, to condemn the errors of Arius, as the basis of that profession of the Faith which,—with the addition made at the Second General Council of Constantinople in 381, (from "the Lord and Giver of life" to the end,) to meet the heresy of Macedonius,—was confirmed and finally adopted by the Third General Council of Ephesus in 431, and by the Fourth, that of Chalcedon, in 451. [See Hammond's "Definitions of Faith and Canons of the Universal Church."]

The Nicene, or, more correctly, the Niceno-Constantinopolitan Creed, from the solemn sanction thus given to it by the great Œcumenical Councils, stands in a position of greater authority than any other; and amid their long-standing divisions is a blessed bond of union between the three great branches of the One Catholic Church—the Eastern, the Roman, and the Anglican, of all whose Communion Offices it forms a part. It is very seriously to be regretted that the American portion of the Anglican Communion has made its use in the Communion Office optional, giving the Apostles' Creed as an alternative.

The shorter draught of the Creed as it came from the Nicene Council contained the words *Θεὸν ἐκ Θεοῦ*, which the Council of Constantinople omitted as unnecessary, and the words *Deum de Deo* do not occur in the Creed as given in the Gelasian Sacramentary. [Muratori, Lit. Rom. i. 540.] But they have since been universally restored throughout the Western Church.

The words "et Filio" or "Filioque" of the Procession of the Holy Ghost, have, as is well known, never been admitted into the Creed by the Eastern Church. They were first introduced,

probably, as an additional protest against the Arian denial of the full Godhead of the Son, by the Spanish Church, at the great Council of Toledo in 589; or, according to Bingham, at the still earlier Council of Bracara in 411. Some however think that they cannot be traced with certainty higher than the Toledan Council of 633. [Guetté, Papauté Schismatique, p. 335.] The addition first became of importance towards the end of the eighth century, when the doctrine of the procession of the Holy Ghost from the Son was wielded as a theological weapon against the adoptionist heresy of the Spanish Bishops, Felix and Elipandus.

It was then generally adopted through Gaul and Germany, chiefly through the influence of Charlemagne, who is said to have written the hymn *Veni, Creator*; and although Pope Leo III., on the subject being referred to him by a Council held at Aix-la-Chapelle in 809, declined to sanction it, and caused a copy of the Creed without the "Filioque" to be engraved on silver plates and set up in St. Peter's: Pope Nicholas I., the great rival of the patriarch Photius, half a century later, insisted, in spite of the protests of the Greeks, on its insertion throughout the churches of the West. The dispute was embittered by the growing assumptions of the Roman See, which have always been steadfastly resisted by the Eastern Church; and the rupture was unhappily completed on July 16, 1054, when the legates of Pope Leo IX. laid on the altar of St. Sophia at Constantinople a writ of Excommunication against Michael Cerularius the Patriarch, which was answered by an anathema on the part of the Patriarch and his clergy.

The resistance of the Easterns to the insertion of the "Filioque" seems to have been influenced principally by these considerations. 1. An objection to the doctrine, if it was intended to assert that the Holy Spirit proceeds from the Son in the same sense, that, namely, of eternal derivation, in which He proceeds from the Father. This they thought was to trench on the great fundamental verity of one sole *Ἀρχή*, or Originating Principle, in the Godhead. The being the sole fount of Deity was, they argued, not one of the Substantial attributes of Godhead as such, since then it would belong equally to each of the Three Blessed Persons; but the distinctive Personal attribute of the Father only, as it is the distinctive Personal attribute of the Son that His Godhead is eternally derived from the Father by way of Generation, and of the Holy Spirit that His Godhead is eternally derived from the Father by way of Procession. And they maintained that the passages of Holy Scripture urged in defence of the eternal Procession of the Holy Ghost from the Son, referred only to His temporal mission by the Son; and that on so mysterious a subject it was safer to keep strictly, as the Œcumenical Councils had done, to the plain letter of Holy Scripture, which affirms expressly that

¹ Some of the earlier creeds may be seen in Harvey's History and Theology of the three Creeds, Heurtley's Harmonia Symbolica, Walchius' Bibliotheca Symbolica, and Bingham's Antiquities, X. iii. 4. See also pp. 17—21 and 36—38 of this work.

¶ *Then the Curate shall declare unto the people what holy-days, or fasting-days, are in the week following to be observed. And then also (if occasion be) shall notice be given*

of the Communion; and the Banns of Matrimony published; and Briefs, Citations, and Excommunications read. And nothing shall be proclaimed or published in

the Holy Ghost proceedeth from the Father, but does not affirm expressly that He proceedeth from the Son.

2. An objection to any unauthorized interpolation in the universally accepted Creed of Christendom, resting on the universally admitted authority of the Second and Fourth General Councils, especially when it originated in a local Church of the then unsettled and unlettered extreme West, and afterwards enforced by the Papal See very much by way of asserting and establishing its insolent claims of supremacy, and of dominion over the Faith of the Church.

At the English Reformation the question was not raised, and the Creed in this respect continued as before¹.

Then the Curate shall declare unto the people] We happen to have two very ancient notices that were given out to the people during Divine Service in the early Church. The one is the notification of Easter, which was given on the feast of the Epiphany, according to the Ambrosian rite, and which will be found in a note at p. 104. This is placed after the Collect "Super Populum" in the Missal of St. Ambrose, and was probably, therefore, read at an analogous part of the Service to that directed above. The other is a notice by St. Augustine in the following words:—"I suggest to you, Beloved, what ye know already. To-morrow dawns the anniversary day of the Ordination of the venerable Lord Aurelius. He asks and admonishes you by my humble ministry that you will, of your charity, grant him a meeting with all devotion at the basilica of Faustus. Thanks be to God." [Serm. cxi. Ben. ed., lxi. Oxford transl.] In mediæval times it was the custom (according to Cardinal Bona) to give out notices of feasts and fasts after the Benediction, which occurred in the part of the Service that comes between the Consecration and the Communion, and he gives some examples of these and other notices (including one of Baptism) from a Roman Sacramentary written before the ninth century. [Rer. Liturg. ii. 16.] The practice of interpolating such notices in the Communion Office is therefore one of great and apparently Primitive antiquity. In the Church of England it appears to have been the mediæval custom to associate the bidding of Holydays with the bidding of Prayers, a list of Festivals having been found written on the same parchment, from which the former was evidently read, in a fourteenth century MS. printed by L'Estrange².

The Sixty-fourth Canon directs as follows:—

"CANON 64.

Ministers solemnly to bid Holydays.

Every Parson, Vicar, or Curate shall, in his several charge, declare to the people, every Sunday, at the time appointed in the Communion-book, whether there be any Holydays or Fasting-days the week following. And if any do, hereafter, wittingly offend herein, and being once admonished thereof by his Ordinary, shall again omit that duty, let him be censured according to law, until he submit himself to the due performance of it."

And then . . . of the Communion] The notice here directed does not refer to either of the Exhortations subsequently printed, as they are ordered by the rubric preceding them to be used after the Sermon, this notice being before it. There is some confusion in the rubrics, both of which belong to an unhappy time of rare celebrations and communions; and neither of them come into operation where the Holy Communion is regularly celebrated, as it undoubtedly should be, every Sunday. In the one rubric the parenthesis "(if occasion be)" indicates that such notice is left to the discretion of the minister; and in the other the meaning plainly is, that the exhortations are to be used on the Sunday or

Holyday preceding the Communion, if the celebration of it is not a regular part of the Sunday Service, and "warning" is therefore necessary.

the Banns of Matrimony published] This portion of the rubric has been altered by the Delegates of the Press at Oxford, and the Synodics at Cambridge, without any authority whatever, in all Prayer Books printed during the last sixty years. The authoritative rubric is as above, and could only be altered by the same constitutional authority which imposed it³. By Lord Hardwicke's Act, 26 Geo. II., c. 33 (1753), it was enacted that "all Banns of Matrimony shall be published in an audible manner in the Parish Church according to the form of words prescribed by the rubric affixed to the Office of Matrimony in the Book of Common Prayer, upon three Sundays preceding the Solemnization of Marriage, during the time of Morning Service, or of Evening Service (if there be no Morning Service in such church upon any of those Sundays) immediately after the Second Lesson, and all other the rules prescribed by the said rubric concerning the publication of Banns, and the solemnization of Matrimony, and not hereby altered, shall be duly observed."

It will be seen that this clause does not define any thing with respect to the time of publication at the "Morning Service," leaving it still to take place after the Nicene Creed, or (which is the same thing when there is no Sermon) "immediately before the sentences for the Offertory." A judicial decision on this subject, and some farther particulars, will be found in the notes to the Marriage Office.

Briefs] These were letters patent issued by the Sovereign, directing the collection of alms for special objects named in them. They were granted for building and repairing churches, and for many benevolent purposes (such as the compensation of losses by fire), which are now provided for by societies or public subscriptions. Great abuses arose out of Briefs, and a statute was passed to regulate them in Queen Anne's reign. [4 Anne, c. 14.] The abuses still continued, however, as will be seen by the following particulars of ninety-seven briefs for repairing or rebuilding churches or chapels, and forty-seven briefs for accidents by fire, inundations, &c., issued between Michaelmas, 1805, and Michaelmas, 1818:—

	Michaelmas, 1805.	Estimates of money required.	Sums collected.	Net proceeds.
	to Michaelmas, 1818.	£ s. d.	£ s. d.	£ s. d.
97 briefs for churches, &c.	125,240 19 4½	35,857 6 7½	14,297 14 4½	
47 ——— accidents, &c.	34,884 15 3½	31,656 12 8½	14,606 18 7	
144	£160,125 14 8½	67,513 19 4½	28,904 12 11½	

An attempt was again made to reform the system in 1821, but with so little success that Briefs were at last abolished, in 1828, by 9 Geo. IV., c. 28. "King's Letters," which were only discontinued five or six years ago, were documents of a similar character, and one granted by Charles II., for Chelsea Hospital, (but never used,) is among Archbishop Sancroft's papers in the Bodleian. These were granted, in recent times, to the Incorporated Societies for Church Building, Missions, and Education.

Citations] "A citation is a judicial act, whereby the defendant, by authority of the judge (the plaintiff requesting it), is commanded to appear, in order to enter into suit, at a certain day, in a place where justice is administered." [Burn's Ecc. Law.] They were read after the Offertory in the Mediæval Church. The only kind of Citation ever heard in church at the present day is the "Si quis" of candidates for Holy Orders, calling upon any persons who know reasons why they should not be ordained to declare those reasons to the Bishop.

Excommunications] These are sentences of ecclesiastical censure passed by competent authority, that is, by some eccle-

¹ The standard works on the Nicene Creed are those of Bishop Bull and Bishop Forbes of Brechin. There is an admirable old English exposition of it, with the above translation, in "the Mirror of our Lady."

² Alliance Div. Off. p. 262. Ang. Cath. Lib. Ed.

³ See pp. xli—xliii.

⁴ See also 4 Geo. IV. c. 76, 1823.

the Church, during the time of Divine Service, but by the Minister: nor by him any thing, but what is prescribed in the Rules of this Book, or enjoined by the Queen, or by the Ordinary of the place.

¶ *Then shall follow the Sermon, or one of the Homilies already set forth, or hereafter to be set forth, by Authority.*

¶ *Then shall the Priest return to the Lord's Table, and begin the Offertory, saying one or more of these Sentences following, as he thinketh most convenient in his discretion.*

Matt. v. 16.
[1]

LET your light so shine before men, that they may see your good works, and glorify your Father which is in heaven.

Matt. vi. 19, 20.
[2]

Lay not up for yourselves treasure upon the earth; where the rust and moth doth corrupt, and where thieves break through and steal: but lay up for yourselves treasures in heaven; where neither rust nor moth doth corrupt, and where thieves do not break through and steal.

Whatsoever ye would that men should do unto you, even so do unto them; for this is the Law and the Prophets.

Not every one that saith unto me, Lord, Lord, shall enter into the Kingdom of heaven; but he that doeth the will of my Father which is in heaven.

Zacchæus stood forth, and said unto the Lord, Behold, Lord, the half of my goods I give to the poor; and if I have done any wrong to any man, I restore four-fold.

Who goeth a warfare at any time of his own cost? Who planteth a vineyard, and eateth not of the fruit thereof? Or who feedeth a flock, and eateth not of the milk of the flock?

If we have sown unto you spiritual things, is it a great matter if we shall reap your worldly things?

siastical judge or ordinary. Canon 65 fully explains this part of the rubric. [See also Palmer's Orig. Liturg. ii. 384.]

And nothing shall be proclaimed. Many Acts of Parliament required that parochial notices respecting purely secular matters should be publicly read in church; and the example had been followed in respect to numberless matters of the same kind without the same authority. All such enactments were repealed by 7 Will. IV., and 1 Vict. c. 45, which thus practically enforced the authority of the rubric.

Then shall follow the Sermon. No authority is here given for that use of the academical gown in preaching which was once so common. Nor is it clear whether the Celebrant, if he is also the preacher, is to lay aside his Vestment. The ancient custom was to preach from the altar steps, and pulpits were far from being universal in churches when this rubric was first inserted. For a sermon preached from the pulpit the Eucharistic Vestment seems scarcely fitting, though it would be strictly so if the sermon was preached from the altar.

The only form of prayer before sermon which has any authority whatever is that enjoined in the Fifty-fifth Canon.

"CANON 55.

The form of a Prayer to be used by all Preachers before their Sermons.

Before all Sermons, Lectures, and Homilies, the Preachers and Ministers shall move the people to join with them in Prayer in this form, or to this effect, as briefly as conveniently they may: Ye shall pray for Christ's holy Catholic Church, that is, for the whole congregation of Christian people dispersed throughout the whole world, and especially for the Churches of England, Scotland, and Ireland: and herein I require you most especially to pray for the King's most excellent Majesty, our Sovereign Lord James, King of England, Scotland, France, and Ireland, Defender of the Faith, and Supreme Governor in these his realms, and all other his dominions and countries, over all persons in all causes, as well Ecclesiastical as Temporal: ye shall also pray for our gracious Queen Anne, the noble Prince Henry, and the rest of the King and Queen's royal issue: ye shall also pray for the Ministers of God's holy Word and Sacraments, as well Archbishops and Bishops, as other Pastors and Curates: ye shall also

pray for the King's most honourable Council, and for all the Nobility and Magistrates of this realm; that all and every of these, in their several callings, may serve truly and painfully to the glory of God, and the edifying and well-governing of His people, remembering the account that they must make: also ye shall pray for the whole Commons of this realm, that they may live in the true faith and fear of God, in humble obedience to the King, and brotherly charity one to another. Finally, let us praise God for all those which are departed out of this life in the faith of Christ, and pray unto God that we may have grace to direct our lives after their good example; that this life ended, we may be made partakers with them of the glorious resurrection in the life everlasting; always concluding with the Lord's Prayer."

This is a modernized form of the ancient "Bidding of the Bedes," but is seldom used except in Cathedrals and Colleges¹. It was enjoined on preachers in the sixteenth and seventeenth centuries, on account of the iniquitous use which was made of their so-called prayers before the sermon by the Puritans; some of whom made it a weekly vehicle for teaching sedition and schism². It may be doubted whether the Bidding Prayer was ever intended to be used for Sermons preached during the Communion Service. When it was inserted in the Canons, Sermons were often preached apart from prayers, as at Paul's Cross, and as the University Sermons are still preached at Oxford and Cambridge. In similar cases it would still be very appropriate.³

THE OFFERTORY.

The solemn oblation of the elements to be consecrated for the Holy Communion, has always formed a prominent feature of the Liturgy⁴. In the Eastern Church the elements are prepared in

¹ For ancient forms of this see Liber Festivalis, L'Estrange's Alliance of Div. Offices, Maskell's Mon. Rit. iii. 342. Coxe's Forms of Bidding Prayer with Introduction and Notes. 1840.

² See a single instance, extending from p. 97 to p. 109 of Mr. Coxe's volume.

³ The writer, commonly called Dionysius the Areopagite, tells us that after the exclusion of the Catechumens and persons under penance, the ministers and priests "then place upon the altar of God the holy bread and the cup of blessing." [De Eccles. Hierarchia, cap. 3. Op. Tom. i. p. 187 D.]

- 1 Cor. ix. 13, 14. Do ye not know, that they who minister about holy things live of the sacrifice; and they who wait at the altar are partakers with the altar? Even so hath the Lord also ordained, that they who preach the Gospel should live of the Gospel. [8]
- 2 Cor. ix. 6, 7. He that soweth little shall reap little; and he that soweth plenteously shall reap plenteously. Let every man do according as he is disposed in his heart, not grudgingly, or of necessity; for God loveth a cheerful giver. [9]
- Gal. vi. 6, 7. Let him that is taught in the Word minister unto him that teacheth, in all good things. Be not deceived, God is not mocked: for whatsoever a man soweth that shall he reap. [10]
- Gal. vi. 10. While we have time, let us do good unto all men; and specially unto them that are of the household of faith. [11]
- 1 Tim. vi. 6, 7. Godliness is great riches, if a man be content with that he hath: for we brought nothing into the world, neither may we carry any thing out. [12]
- 1 Tim. vi. 17—19. Charge them who are rich in this world, that they be ready to give, and glad to distribute; laying up in store for themselves a good foundation against the time to come, that they may attain eternal life. [13]
- Heb. vi. 10. God is not unrighteous, that he will forget your works, and labour that proceedeth of love; which love ye have shewed for his Name's sake, who have ministered unto the saints, and yet do minister. [14]
- To do good, and to distribute, for- get not; for with such sacrifices God is well pleased. Heb. xiii. 16. [15]
- Whoso hath this world's good, and seeth his brother have need, and shutteth up his compassion from him, how dwelleth the love of God in him? 1 John iii. 17. [16]
- Give alms of thy goods, and never turn thy face from any poor man; and then the face of the Lord shall not be turned away from thee. Tob. iv. 7. [17]
- Be merciful after thy power. If thou hast much, give plenteously: if thou hast little, do thy diligence gladly to give of that little: for so gatherest thou thyself a good reward in the day of necessity. Tob. iv. 8, 9. [18]
- He that hath pity upon the poor lendeth unto the Lord: and look, what he layeth out, it shall be paid him again. Prov. xix. 17. [19]
- Blessed be the man that provideth for the sick and needy: the Lord shall deliver him in the time of trouble. Ps. xli. 1. [20]
- ¶ Whilst these Sentences are in reading, the Deacons, Churchwardens, or other fit person appointed for that purpose, shall receive the alms for the poor, and other devotions of the people, in a decent basin, to be provided by the Parish for that purpose, and reverently bring it to the Priest; who shall humbly present and place it upon the holy Table. 1 Cor. xvi. 1, 2. Rom. xvi. 26. Gal. ii. 10. Acts vi. 3. Matt. v. 23, 24. Eccles. vii. 10. 31, 32.

the Prothesis, the northern of the chapels on either side of the altar, with a special service, called "The Office of the Prothesis," and are taken to the altar with much ceremony in a procession called "The Great Entrance." Then they are offered to God, with a Prayer of Oblation, the following being that appointed in the Liturgy of St. Chrysostom, which is now generally used in the East and in Russia:—

"Lord, God Almighty, Only Holy, Who receivest the sacrifice of praise from them that call upon Thee with their whole heart, receive also the supplication of us sinners, and cause it to approach to Thy holy Altar, and enable us to present gifts to Thee, and spiritual sacrifices for our sins, and for the errors of the people; and cause us to find grace in Thy sight, that this our sacrifice may be acceptable unto Thee, and that the good Spirit of Thy grace may tabernacle upon us, and upon these gifts presented unto Thee, and upon all Thy people. Through the mercies of Thine only-begotten Son, with whom Thou art to be blessed, and with the all-lowly, and good, and quickening Spirit, now and ever, and to ages of ages."

In the unreformed Liturgy of the Church of England, a short Anthem, called "Offertorium," was sung at this part of the service, and then the Celebrant said the following prayer:—"Accept, O holy Trinity, this Oblation which I offer to Thine honour,

[in honour of the Blessed Mary and of all Thy Saints,] for my sins and offences, for the wealth of the living, and for the rest of all the faithful departed. May this new sacrifice be acceptable to Almighty God, in the Name of the Father, and of the Son, and of the Holy Ghost."

In the Communion Office of 1549 there was no special prayer connected with the Oblation of the elements; but there was the following rubric:—"Then shall the Minister take so much bread and wine as shall suffice for the persons appointed to receive the Holy Communion, laying the bread upon the corporas, or else in the paten, or in some other comely thing² prepared for that purpose: and putting the wine into the chalice, or else in some fair or convenient cup prepared for that use (if the chalice will not serve); putting thereto a little pure and clean water³, and setting both the bread and wine upon the altar."

¹ No doubt this is a late insertion.

² Probably a "ciborium" was meant.

³ This ancient custom of mingling a small quantity of water with the wine is one which many good men have recommended and practised. Wheatley remarks respecting the usage: "It must be confessed that the mixture has, in all ages, been the general practice, and for that reason was enjoined to be continued in our own Church by the first Reformers. And though in the next Review the order for it was omitted, yet the practice of

¶ *And when there is a Communion, the Priest shall then place upon the Table so much Bread and Wine, as he shall think sufficient. After which done, the Priest shall say,*

Let us pray for the whole state of Christ's Church militant here in earth.

Deut. xxxii. 40.
1 Tim. ii. 1, 2.
Phil. iv. 6.
2 Sam. xvi. 4.
Acts xxiv. 17.
Heb. xiii. 16.
Gal. vi. 6.
Ps. xx. 1, 3, vi. 9.
John x. 15, 16.
xvii. 17, 20.

ALMIGHTY and everliving God, who by thy holy Apostle hast taught us to make prayers, and supplications, and to give thanks, for all men; We humbly beseech thee most

mercifully [*to accept our alms and If there be no oblations, and*] to receive these our prayers, which we offer unto thy Divine Majesty; beseeching thee to inspire continually the universal Church with the spirit of truth, unity, and concord: And grant, that all they that do confess thy holy Name may agree in the truth of thy holy word, and live in unity, and godly love. We beseech thee also to save and defend all Christian Kings, Princes, and Governours; If there be no alms or oblations, then shall the words [of accepting our alms and oblations] be left out unsaid.

Eph. iv. 1-4.
Rom. x. 9, 10.
1 Cor. i. 10.
2 Cor. xiii. 11.
John xiii. 35.
1 Sam. x. 24.
Ps. cxlv. 10.
1 Tim. ii. 1, 2.
Exod. xviii. 21, 22.
Prov. xi. 14.
Deut. i. 17.

After which followed, "The Lord be with you," "Lift up your hearts," and the Sanctus with its Preface.

The substance of this rubric is retained in that which immediately precedes the Prayer for the Church Militant, and its significance was heightened in the revision of 1661 by the introduction of the word "oblations" into that prayer. The rubric and the words of the prayer together now give to our Liturgy as complete an "Oblation of the Elements" as is found in the ancient Offices. This should be distinctly shown by the reverent method of "placing" the bread and wine upon the Lord's Table; so that it may be seen they are placed there as a devout offering to God of His creatures of bread and wine that He may accept them at our hands (as the Lord accepted the five loaves from His disciples), to be by Him eucharistized to the higher sphere and purpose of the new creation. A separate Prayer of Oblation is still used in the Office for the Holy Communion when celebrated at Coronations. It is as follows:—"Bless, O Lord, we beseech Thee, these Thy gifts, and sanctify them unto this holy use, that by them we may be made partakers of the Body and Blood of Thine only-begotten Son Jesus Christ, and fed unto everlasting life of soul and body."

A secondary part of the Offertory is the collection and offering of "alms for the poor, and other devotions of the people." The words "accept our alms" were inserted where they now stand in 1552, but the rubric directing the churchwardens to put them "into the poor men's box," it is doubtful whether they were offered upon the altar. Perhaps it was this doubtful character of the rubric which led to such a distinct direction as that which we now have, and which was inserted in 1661. This direction should also regulate the collection of alms in Church at other services.

The idea of an offering of alms at the Holy Communion arises out of the idea of the oblation of the elements. The elements are the materials of the sacrifice about to be offered to God and partaken of by the communicants; and (as under the Jewish system) such materials are provided by those who are to benefit by the sacrifice. But since so small a quantity of material is not recognizable as an offering from many individuals, each supplements it according to his ability with an offering of money to be

it was continued in the King's Chapel, all the time that Bishop Andrewes was dean of it." "We ought by no means to censure others, who put water into the Cup, for they have the consent of the Church Catholic of all ages with them in this particular. This practice remained universal for the first 1500 years after Christ in all Churches, excepting that of Armenia. Pfaffius shows that the cup of blessing among the Jews did for the most part consist of wine mixed with water, and from thence concludes that the Primitive Church took this practice from them, as it is certain they did several others." [Johnson, Unbl. Sacrif., Part ii. ch. i. § iv. vol. ii. p. 84.] "It seems to me to have been an Apostolical use, and very probably practised by Jesus Christ Himself; therefore I cannot but wish that it might be restored." [Ibid. p. 203. See also Palmer, Origines Liturg., chap. iv. § 9; and Dr. Littledale's pamphlet, "The Mixed Chalice."]

Symbolically the mixture of water with the wine represents the union of the human with the Divine nature in the Incarnation. It is also a lively memorial of Him Who for our redemption did shed out of His most precious side both Water and Blood.

applied as alms for the poor, whom "always ye have with you," or for some sacred object connected with the work of Christ and of the Church. Such an offering at such a time is very significant; for, first, "we thereby acknowledge God's sovereignty over all, and His great bounty to us in particular," that "all things come of Him," and of His own do we give Him; fulfilling His command of not "appearing before Him empty;" and, secondly, the people acknowledge and fulfil their duty of providing for the maintenance of God's Priests, of God's Poor, of God's Church, His consecrated fabrics and His holy services.

In his Durham Book, Cosin made a re-arrangement of, and some additions to, the Offertory sentences, which are worth notice. He annexed the following direction to the printer:—"Print the first thirteen of these sentences at a distance from the six following: and those six at a distance from the four next after: and the last (being the 26) at a distance by itself." This classification may be understood by comparing the following numbers and additions with the numbers affixed to the sentences in the margins above. The two from Tobit were included by Cosin in the third class, but appear to have been erased by the Revision Committee, though still printed in the Prayer Book.

I.

1, 2, 3, 4, 12, 13, 14, 15. Gen. iv. 3. Exod. xxv. 2. Deut. xvi. 16. Ps. xcvi. 7, 8. Mark xii. 41; and Luke xxi. 3, 4.

II.

6, 7, 8, 9, 10, 11.

III.

5, 16, 20, 19 [17, 18, these two, from Tobit, erased by Saucroft].

IV.

Blessed be Thou, O God, for ever. Thine, O Lord, is the greatness and the glory. For all that is in the heaven and in the earth is Thine. Both riches and honour come of Thee; and of Thine own do we give unto Thee. As for me, in the uprightness of my heart I have willingly offered all these things. And now have I seen with joy Thy people who are here present to offer willingly unto Thee. 1 Chron. xxix. 11-13. 17.

Another classification may be suggested, as follows:—
For general use, 1, 2, 3, 4, 9, 12, 13, 15, 18.

"the poor, 5, 17, 19, 20.

"support of Churches, Clergy, and Missions, 6, 7, 8, 10.

"special Church charities, 11, 14, 16.

"Hospitals, 20.

§ Prayer for the Church.

The "Oremus" of this prayer is formed from the title of an ancient prayer for the living and the departed, which was in use before the Reformation, and which is printed (from a volume of Hours dated 1531, and belonging to J. D. Chambers, Esq.) in

Rom. xiii. 3, 4.
 1 Pet. ii. 13, 14.
 Phil. i. 1, 2.
 2 Thess. iii. 1.
 Eph. vi. 18, 19.
 1 Tim. iv. 12.
 Matt. xxviii. 19,
 20.
 Acts xx. 7.
 1 Cor. xiv. 26, 40.
 Neh. viii. 2-5.
 Rev. ii. 11.
 James i. 19, 21.
 2 Tim. iii. 15-19.
 Luke i. 74, 75.

and specially thy servant *VICTORIA* our Queen, that under her we may be godly and quietly governed: And grant unto her whole Council, and to all that are put in authority under her, that they may truly and indifferently minister justice, to the punishment of wickedness and vice, and to the maintenance of thy true religion, and virtue. Give grace, O heavenly Father, to all Bishops and Curates, that they may both by their life and doctrine set forth thy true and lively Word, and rightly and duly administer thy holy Sacraments: And to all thy people give thy heavenly grace; and especially to this congregation here present; that, with

meek heart and due reverence, they may hear, and receive thy holy Word; truly serving thee in holiness and righteousness all the days of their life. And we most humbly beseech thee of thy goodness, O Lord, to comfort and succour all them, who in this transitory life are in trouble, sorrow, need, sickness, or any other adversity. And we also bless thy holy Name for all thy servants departed this life in thy faith and fear; beseeching thee to give us grace so to follow their good examples, that with them we may be partakers of thy heavenly kingdom: Grant this, O Father, for Jesus Christ's sake, our only Mediator and Advocate. *Amen.*

Heb. xiii. 5.
 Ps. cxiv. 9.
 ciii. 13-17.
 2 Cor. i. 3, 4.
 Ps. xxxi. 7.
 Rev. xiv. 13.
 vii. 13-17.
 Heb. xi. 13, 39,
 40. xii. 1, 2.
 vi. 12.
 Col. i. 12.
 2 Tim. iv. 18.
 1 Tim. ii. 5.

the "Directorium Anglicanum" [p. 53, 2nd ed.]. This prayer is entitled, "¶ A generall and devout prayre for the good state of oure moder the Church militant here in erth." The general character of the prayer is similar to that of the present Church Militant Prayer, but it ends with the following words,—"et omnibus fidelibus vivis et defunctis, in terra viventium vitam æternam pariter et regimen concedas."

Prefaces of a similar kind to that here ordered were affixed to each of the nine collects for Good Friday in the Salisbury Missal; and the first of them began, "Oremus, dilectissimi, nobis in primis pro ecclesia sancta Dei . . .," the preceding rubric ending, "*Et primo pro universali statu ecclesia.*" It was adopted before the Consecration Prayer of the Liturgy of 1549, in the form, "Let us pray for the whole state of Christ's Church," and the ancient phrase "militant here on earth" was added in 1552. Bishop Cosin altered it in his Durham Book to "Let us offer up our prayers and praises for the good estate of Christ's Catholick Church," making the same change in the title of the prayer in the first rubric at the end of the Communion Office. In the latter place it was so printed in all the Sealed Books, and it is so written in the duplicate MS. of the Prayer Book sent to Ireland. In some of the Sealed Books it was, however, altered to the present form by the correcting Commissioners.² But it is still to be found printed in Cosin's form in many Prayer Books of a date near to the time of the revision, from which it may be concluded that it was not altered in all the Sealed Books.

The Prayer for the Church Militant is the first portion of the Canon as it was re-formed in 1549 [see the Appendix to this Office]. It was separated from that part of the Canon more immediately associated with the act of Consecration, in 1552, and thrown back into this early part of the service. At the same time, the commendation of the congregation present was put in its present short form, instead of in one which specified that they were met to commemorate the death of Christ. Bishop Cosin wished to restore the passage in a bracket, with a marginal rubric, as follows:—

"[And we commend especially unto Thy merciful goodness this Congregation which is here assembled in Thy Name, to celebrate the Commemoration of the most precious death and Sacrifice of Thy Son and our Saviour Jesus Christ.]"

He also desired to insert after the words "their life," a full

When there is no Communion these words thus enclosed [] are to be left out.

and definite commemoration of the departed, after the pattern of the older Liturgy, and as it had been adopted in the Scottish Office of 1637. His MS. insertion in the margin of the Durham Book is as follows:—

"And we also bless Thy holy Name for all these Thy servants, who having finished their course in faith do now rest from their labours. And we yield unto Thee most high praise and hearty thanks for the wonderful grace and virtue declared in all Thy Saints, who have been the choice vessels of Thy grace, and the Lights of the world in their several generations: most humbly beseeching Thee that we may have grace to follow the example of their stedfastness in Thy faith, and obedience to Thy holy commandments: that at the day of the general Resurrection, we and all they which are of the mystical Body of Thy Son may be set on His right hand, and to hear that his most joyful voice, 'Come, ye blessed of My Father, inherit the kingdom prepared for you from the foundation of the world.' Grant, &c."

A prayer similar in character to the Prayer for the Church Militant is found in all Liturgies, although placed in closer connexion with the Consecration Prayer.³ The object of the prayer, whatever its position, is to present a supplication for all members of the Church at the time when the offering up the Eucharist makes intercession a special duty of love, and gives to it a special hope of prevailing power. Condensed as our present form of this prayer is, yet its comprehensiveness is very observable; and, though it is brief, it is as all-inclusive as the Litany. Having made the verbal offering of the Alms and of the Oblations, it proceeds to pray for the living under five principal divisions, which it would be well to mark in the typographical arrangement of the prayer by beginning a fresh paragraph for each. 1. For the Catholic Church. 2. For Christian Princes. 3. For the Bishops and Clergy. 4. For the People. 5. For the Afflicted. This prayer is, indeed, so exhaustive as to render it unnecessary to use the Litany immediately before the Communion Office, as part of the same continuous service. In Churches where Mattins, Litany, and Holy Communion, are thought to make too long a

³ In the Scotch Communion Office this Prayer (which in its commemoration of the departed is fuller than ours, and keeps more closely to the Liturgy of 1549) follows immediately after the Prayers of Consecration and Oblation. This is its position in the Liturgies of St. James, St. Basil, St. Chrysostom, and the Clementine; but in the Alexandrine Liturgy of St. Mark, and in the Mozarabic and ancient Gallican Liturgies, the great Intercessory Prayer for Living and Dead preceded the Consecration. In the Latin forms, Roman, Ambrosian, and Anglican, the Commemoration of the Living preceded Consecration: that of the Departed followed it.

For the general similarity between this prayer and similar ones in the Primitive Church, compare Tertull. Apol. 39, and St. Cyril's fifth Catechetical Lecture on the mysteries.

¹ A foot-note at p. 65 must be supplemented by what is here stated.

² See p. xliii.

¶ When the Minister giveth warning for the celebration of the holy Communion, (which he shall always do upon the Sunday, or some holy-day, immediately preceding), after the Sermon or Homily ended, he shall read this Exhortation following.

Lev xxiii. 1-4.
2 Chron. xxxv. 6.
Rev. iii. 20.
Heb. xiii. 10.
xii. 28.
Acts ii. 41, 42.
1 Cor. xi. 23-25.
Gal. vi. 14.
Heb. ix. 22, 11,
12, x. 12, 14.
Col. i. 12.
Luke xxii. 19.
1 Cor. ii. 24.
Heb. x. 26.
Ps. cxvi. 12, 13.
Eph. v. 20.
Heb. xiii. 15.
Rom. v. 8.
John vi. 53-56.
Gal. ii. 20.
1 Cor. x. 16.
xi. 26, 27.
Ezek. iii. 18, 10.
1 Cor. xi. 29, 28.
2 Cor. xiii. 5.
1 Cor. xi. 31.
Jer. xlii. 20.
John xiii. 10, 11.
Rev. xix. 8.
Isa. lxi. 10.
Matt. xxii. 11-13.
1 Cor. x. 21.
John vi. 35, &c.
1 Cor. x. 16.
ii. 27, 28.

DEARLY beloved, on — day next I purpose, through God's assistance, to administer to all such as shall be religiously and devoutly disposed the most comfortable Sacrament of the Body and Blood of Christ, to be by them received in remembrance of his meritorious Cross and Passion, whereby alone we obtain remission of our sins, and are made partakers of the Kingdom of heaven. Wherefore it is our duty to render most humble and hearty thanks to Almighty God our heavenly Father, for that he hath given his Son our Saviour Jesus Christ, not only to die for us, but also to be our spiritual food and sustenance in that holy Sacrament. Which being so divine and comfortable a thing to them who receive it worthily, and so

dangerous to them that will presume to receive it unworthily; my duty is to exhort you in the mean season to consider the dignity of that holy mystery, and the great peril of the unworthy receiving thereof; and so to search and examine your own consciences, (and that not lightly, and after the manner of dissemblers with God; but so) that ye may come holy and clean to such a heavenly feast, in the marriage-garment required by God in holy Scripture, and be received as worthy partakers of that holy Table.

The way and means thereto is; First, to examine your lives and conversations by the rule of God's commandments; and whereinsoever ye shall perceive yourselves to have offended, either by will, word, or deed, there to bewail your own sinfulness, and to confess yourselves to Almighty God, with full purpose of amendment of life. And if ye shall perceive your offences to be such as are not only against God, but

Matt. xxii. 11.

Hag. i. 5.
Isa. viii. 20.
John xii. 47, 48.
2 Tim. iii. 16.
Ps. cxix. 136.
John iii. 19, 20.
Eccl. vii. 20.
2 Cor. vii. 10, 11.
Job xxxiv. 31, 32.
Matt. v. 23-26.
Luke xix. 8.
Exod. xxii. 6, 7.
Lev. xxvi. 40.
Numb. v. 7.
Josh. vii. 19.
Ps. xxxii. 5.
2 Sam. xii. 13.
Ps. li. 2.
Prov. xxviii. 13.
Dan. ix. 20.
Matt. iii. 6.

service at once, as indeed they do, it would be better to let the Communion follow immediately after Mattins, using the Litany as a separate service in the afternoon. This would obviate the sameness of repeated prayers for the same persons and objects, which, more than the actual time taken, is the cause of the common complaints of the length of the Morning Service. Particular intercession should be privately made after the word "adversity," and it is well for the Priest to make a short pause, to allow those present thus silently to commend to God any for whom they are specially bound to pray.

If it be thought by any to be an omission that in this prayer we do not pray for "all sorts and conditions of men," Heathen as well as Christian, but only for Christ's Church, it should be remembered that our Lord Himself in His Eucharistic Intercession expressly says, "I pray not for the world, but for them which Thou hast given Me" [John xvii. 9]. Very observable also is it that the earnest prayer for unity, which is found in the great intercessory Prayer that forms part of every known Christian Liturgy, is a close following of our Blessed Lord's own example at the first Institution of the Eucharist [John xvii. 20-23].

In commemorating the departed at the time of celebrating the Holy Eucharist, the Church of England simply does as every known Church has done from the earliest age in which its Liturgical customs can be traced. The following are some Primitive examples:—

Liturgy of St. James. See Introduction to this Office, p. 156. The first words of commemoration, "... that they may find mercy and grace with all Thy Saints . . ." will be found exactly similar in character to those of the Church Militant Prayer.

Liturgy of St. Mark. "Give rest to the souls of our fathers and brethren that have heretofore slept in the faith of Christ, O Lord our God, remembering our ancestors, fathers, patriarchs, prophets, apostles, martyrs, confessors, bishops, holy and just persons, every spirit that has departed in the faith of Christ, and those whom to-day we keep in memory."

Liturgy of St. Clement. "Let us commemorate the holy martyrs, that we may be deemed worthy to be partakers of their trial. Let us pray for all those who have fallen asleep in the Faith."

Liturgy of St. Chrysostom. "Further, we pray for the blessed and ever-memorable founders of this holy abode, and for all our fathers and brethren that have fallen asleep before us, and lie here; and the orthodox that lie every where." [From the Ectene.] "And, farther, we offer to Thee this reasonable Service on behalf of those who have departed in the Faith, our ancestors, fathers, . . . and every just spirit made perfect in the Faith." [From the Prayer of Oblation.] "And remember all those that are departed in the hope of the resurrection to eternal life, and give them rest where the light of Thy countenance shines upon them." [From the commemoration of the diptychs of the departed.]

It will thus be seen how great a deviation it would be from Primitive Christianity to omit all mention of the deceased members of Christ, at the time when celebrating the great Sacrament of Love by which all the whole Church is bonded together. And it must be considered as great matter for thankfulness, that in all the assaults made upon the Liturgy of the Church of England by persons holding a more meagre belief in things unseen, the Providence of God has preserved the prayer for the whole Church, departed as well as living, in the Prayer for the Church Militant.

THE EXHORTATIONS.

These short homilies were introduced into the Communion Office at a time when the Church of England laity were in danger of two extremes. The first was that almost total neglect of Communion which had sprung up during the Middle Ages: the second was that fearful irreverence towards the Holy Communion which arose from the dreadful principles held respecting it by the Puritans: an irreverence so great as to call out even an Act of Parliament for its suppression. [1 Edw. VI. c. 1, 1547.]

In the face of these dangers, and when Sermons were but rarely preached in comparison with later times, these Exhortations were placed where they are, for instruction of the people, as well as for a hortatory purpose. Although extremely valuable as statements of doctrine, they are not so necessary in times when sermons respecting the Holy Communion are so common as they

1 John i. 9.
Matt. v. 23.
Numb. v. 7.
Luke xix. 8.
Matt. vi. 14.
Eph. iv. 32.
1 Col. iii. 13.
1 Cor. xi. 29.
John xiii. 27.
1 John iii. 20.
2 Sam. xii. 13.
Luke xi. 4.
xvii. 3, 4.
Mark xi. 25.
Matt. xviii. 34, 35.
Col. iii. 13.
1 Cor. xi. 29.
2 Tim. iii. 1, 2.
Luke xi. 52.
Rom. iii. 8.
1 Cor. vi. 9, 10.
Col. iii. 8.
1 Cor. x. 21.
xi. 31.
Luke xxii. 3-6.
21, 22.
Matt. xxvii. 3-5.

Heb. x. 19-22.
xii. 22, 24.
1 John iii. 20, 21.
Rom. xiv. 5.
Ps. liii. 8.
James v. 16.
Jea. i. 4.

also against your neighbours; then ye shall reconcile yourselves unto them; being ready to make restitution and satisfaction, according to the uttermost of your powers, for all injuries and wrongs done by you to any other; and being likewise ready to forgive others that have offended you, as ye would have forgiveness of your offences at God's hand: for otherwise the receiving of the holy Communion doth nothing else but increase your damnation. Therefore if any of you be a blasphemer of God, an hinderer or slanderer of his Word, an adulterer, or be in malice, or envy, or in any other grievous crime, repent you of your sins, or else come not to that holy Table; lest, after the taking of that holy Sacrament, the devil enter into you, as he entered into Judas, and fill you full of all iniquities, and bring you to destruction both of body and soul.

And because it is requisite, that no man should come to the holy Communion, but with a full trust in God's mercy, and with a quiet conscience;

therefore if there be any of you, who by this means cannot quiet his own conscience herein, but requireth further comfort or counsel, let him come to me, or to some other discreet and learned Minister of God's Word, and open his grief; that by the ministry of God's holy Word he may receive the benefit of absolution, together with ghostly counsel and advice, to the quieting of his conscience, and avoiding of all scruple and doubtfulness.

¶ Or, in case he shall see the people negligent to come to the holy Communion, instead of the former, he shall use this Exhortation.

DEARLY beloved brethren, on — I intend, by God's grace, to celebrate the Lord's Supper: unto which, in God's behalf, I bid you all that are here present, and beseech you, for the Lord Jesus Christ's sake, that ye will not refuse to come thereto, being so lovingly called and bidden by God himself. Ye know how grievous and unkind a thing it is, when a man hath prepared a rich feast, decked his table with all kind of provision, so that

2 Tim. ii. 24, 25.
Luke xxii. 32.
John xx. 22, 23.
2 Cor. ii. 10, 11.
Isa. xlii. 2.
John xxi. 23.
Luke x. 16.
Matt. xvi. 19.
xviii. 18.

2 Cor. v. 20.
Cant. v. 1.
Isa. lv. 1, 2.
Rev. xxii. 19.
Luke xiv. 16-23.
Matt. xxii. 2-6.
8, 9.

now are; and they are out of character with the habits of a Church in which there is a regular celebration of the Holy Communion on all Sundays and Holydays. The rubric does not seem to enjoin their constant use; but to require this form of Exhortation to be used at those times when the Minister thinks it necessary to "give warning," that is, to exhort his people, respecting "the celebration of the Holy Communion;" and when so used they are to be used upon "the Sunday, or some Holyday immediately preceding" that on which the celebration is to take place. The tone of the rubric and of the exhortations is plainly fitted to a time of infrequent communions.

§ *The first Exhortation.*

The original of this formed part of the "Order of Communion" set forth in 1548, when a great endeavour was being made to revive the practice of actual Communion among the laity. Who was its author is unknown. It underwent some alterations in 1552, the most important of which was the omission of the following admirable passage respecting Confession and Charity, with which it ended in 1549, "requiring such as shall be satisfied with a general Confession, not to be offended with them that doth use, to their further satisfying, the auricular and secret Confession to the Priest; nor those also which think needful or convenient for the quietness of their own consciences particularly to open their sins to the Priest, to be offended with them which are satisfied with their humble confession to God, and the general confession to the Church; but in all these things to follow and keep the rule of charity; and every man to be satisfied with his own conscience, not judging other men's minds or acts, whereas he hath no warrant of God's Word for the same."

In 1661 some changes were made by Bishop Cosin, the principal being the prefix of the first paragraph, which is in his handwriting in the margin of the Durham Book.

The concluding paragraph of this Exhortation is very important as indicating that, while the Church of England advises auricular confession in some cases [see notes on Visitation of the

Sick], it is yet not considered to be of absolute necessity before the receiving of the Holy Communion, as in the Roman and Eastern Churches, whose laity, as a rule, communicate much less frequently than do those of the Church of England. It is permitted and recommended, and perhaps even enjoined to such as find it necessary for their own comfort; for in the English of 1548 the phrase "let him come" was more probably imperative than merely permissive. It can hardly be questioned that the Church of England regards private Confession as occasional and remedial, not as habitually desirable; as medicine, not regular food. In estimating the teaching of the Prayer Book on this subject, it must always be remembered that an authoritative priestly absolution is provided, both in the Communion Office and in the daily Mattins and Evensong, which only differs from a private absolution in being addressed to individuals as included in a congregation and not separately. [See note on the Absolution in the Communion Office.] The prominence given, in the Revision of 1552, to the Confession and Absolution in the Daily Office, and the intention of the Church, made clearer still in that of 1661, that they should be taken for an effectual Absolution of all them that truly repent and unfeignedly believe, seem to indicate a wish to discourage frequent private Confession, by rendering it less necessary. [See p. 4.]

Ministry of God's Word] This does not mean that the priest is to read some part of the Holy Bible to the penitent, but to give him the "benefit of Absolution." In the language of the period, "God's Word" was a term applied to words pronounced in the Name and by the authority of God, as well as to the Holy Bible. It was just coming into use for the latter, but the former was its more established and popular sense.

§ *The second Exhortation.*

This Exhortation was inserted in 1552, as Cosin thinks at the instance of Bucer, and was then placed between the Church Militant Prayer and the Ordinary Exhortation on giving warning of Communion. Bucer, in the following passage [Censura, c. 27],

Matt. vi. 12.
 Heb. iii. 7, 12.
 x. 25, 38, 39.
 Numb. ix. 10.
 Isa. lxxv. 13.
 Acts xvii. 30, 31.
 Matt. xxi. 28, 29.
 Rom. ii. 4.
 Heb. xii. 25.
 Gal. vi. 7, 8.
 Prov. i. 24—27.

there lacketh nothing but the guests to sit down; and yet they who are called (without any cause) most unthankfully refuse to come. Which of you in such a case would not be moved? Who would not think a great injury and wrong done unto him? Wherefore, most dearly beloved in Christ, take ye good heed, lest ye, withdrawing yourselves from this holy Supper, provoke God's indignation against you. It is an easy matter for a man to say, I will not communicate, because I am otherwise hindered with worldly business. But such excuses are not so easily accepted and allowed before God. If any man say, I am a grievous sinner, and therefore am afraid to come: wherefore then do ye not repent and amend? When God calleth you, are ye not ashamed to say ye will not come? When ye should return to God, will ye excuse yourselves, and say ye are not ready? Consider earnestly with yourselves how little such feigned excuses will avail before God. They that refused the feast in the Gospel, because they had bought a farm, or would try their yokes of oxen, or be-

cause they were married, were not so excused, but counted unworthy of the heavenly feast. I, for my part, shall be ready; and, according to mine Office, I bid you in the Name of God, I call you in Christ's behalf, I exhort you, as you love your own salvation, that ye will be partakers of this holy Communion. And as the Son of God did vouchsafe to yield up his soul by death upon the Cross for your salvation; so it is your duty to receive the Communion in remembrance of the sacrifice of his death, as he himself hath commanded: which if ye shall neglect to do, consider with yourselves how great injury ye do unto God, and how sore punishment hangeth over your heads for the same; when ye wilfully abstain from the Lord's Table, and separate from your brethren, who come to feed on the banquet of that most heavenly food. These things if ye earnestly consider, ye will by God's grace return to a better mind: for the obtaining whereof we shall not cease to make our humble petitions unto Almighty God our heavenly Father.

Luke xiv. 16—24.
 Matt. xxiv. 45, 46.
 1 Pet. v. 2.
 2 Cor. v. 20.
 Jer. l. 5.
 Heb. ii. 3.
 x. 25.
 Luke xxii. 70.
 Matt. xxvii. 40.
 50.
 Acts iv. 12.
 1 Cor. xi. 23—25.
 Luke x. 16.
 Numb. ix. 13.
 Heb. x. 38, 31.
 Prov. xx. 2.
 2 Cor. viii. 12.
 Heb. x. 38, 39.
 Deut. xxxii. 29.
 2 Tim. ii. 7.
 Ps. ii. 12.
 1 Sam. xii. 23.
 1 Kings xviii. 37.
 Rom. x. 1.

¶ *At the time of the Celebration of the Communion, the Communicants being conveniently placed for the receiving of the holy Sacrament, the Priest shall say this Exhortation.*

1 Pet. ii. 11.
 1 Cor. x. 16.
 xi. 28.

DEARLY beloved in the Lord, ye that mind to come to the holy Communion of the Body and Blood of our Saviour Christ, must consider how Saint Paul exhorteth all persons diligently to try and examine themselves, before they presume to eat of that Bread, and drink of that Cup. For as

[GOOD men and women, y charge yow by the Auctoryte of holy churche, that no man nother woman that this day proposyth here to be comenyd [*communicated*] that he go note to Godds bord, lase than he byleue stedfastlych, that the sacrament that he ys avysyd here to reseue, that yt ys

[Harleian MS., 2383.]

pleads earnestly for frequent Communion:—"Modis omnibus instandum, ut qui præsentes sunt communicent. Sed sunt qui in eo nobiscum sentiunt, quo autem id obtineant non veris utuntur rationibus. Alii enim eo rarius S. Cœnam celebrant, ut in anno vix plures quam ter-aut quater. Alii populum qui ad prædicationem Evangelii et preces confluit omnem dimittant, ut Cœnam celebrent cum iis tantum qui volunt eâ communicare. Nam ex eo quod Dominus usum hujus Sacramenti commendavit discipulis suis, ut ceremoniam pertinentem ad solennem sui inter nos celebrandam memoriam, quæ sane a nobis celebrari debet omni die Dominico. Item, ex eo quod Apostolus, 1 Cor. xi. eandem cœnam omni frequentiori cœtui deputat, et quod Ecclesia Apostolica legitur ita fractione panis perseverasse, ut in doctrina Apostolorum, Act. II.; apparet ergo Ecclesias priscas illud ex certa Apostolorum traditione accepisse, ut Sacram Cœnam sin-

gulis diebus Dominicis et Festis, imûo quoties tota conveniebat Ecclesia, exhiberent."

As this Exhortation originally stood, it contained a strong passage about the ill effects of habitually remaining to "gaze" without receiving the Communion, which shows that the habit was an extremely common one at that time. This paragraph, which followed the words "hangeth over your heads for the same," was crossed out in Cosin's book, apparently by Sancroft, as Secretary to the Committee, the ink being of the colour used by him, and not of that used by Cosin.

§ *The third Exhortation.*

conveniently placed] After the Offertory sentences the Liturgy of 1549 has this rubric: "Then so many as shall be partakers of

Acts. i. 38-47.
 John vi. 68, 69.
 57-58. xv. 4.
 xvii. 20-23.
 1 Cor. xi. 27-32.
 Acts xx. 21.
 1 John iv. 7-12.
 Ps. xxvi. 6.
 1. 14.
 cxvii. 12, 13, 17.
 2 Cor. ix. 15.
 Rev. v. 19.
 John iii. 13.
 Phil. ii. 6-8.
 Luke xix. 10.
 i. 78, 79.
 Matt. iv. 14-16.
 Col. i. 12, 13, 21,
 22.
 Gal. iii. 26.
 Exod. xii. 24-27.

the benefit is great, if with a true penitent heart and lively faith we receive that holy Sacrament; (for then we spiritually eat the flesh of Christ, and drink his blood; then we dwell in Christ, and Christ in us; we are one with Christ, and Christ with us;) so is the danger great, if we receive the same unworthily. For then we are guilty of the Body and Blood of Christ our Saviour; we eat and drink our own damnation, not considering the Lord's Body; we kindle God's wrath against us; we provoke him to plague us with divers diseases, and sundry kinds of death. Judge therefore yourselves, brethren, that ye be not judged of the Lord; repent you truly for your sins past; have a lively and stedfast faith in Christ our Saviour; amend your lives, and be in perfect charity with all men; so shall ye be meet partakers of those holy mysteries. And above all things ye must give most humble and hearty thanks to God, the Father, the Son, and the Holy Ghost, for the redemption of the world by the death and passion of our Saviour Christ, both God and man, who did humble himself, even to the death upon the Cross, for us, miserable sinners; who lay in darkness and the shadow of death, that he might make us the children of God, and exalt us to everlasting life. And to the end that we should alway remember the exceeding

Gods body flesche and blode, yn the forme of bred; & that (*which*) he receyvythe afterward, ys no thyng ells but wyne & water, for to clense yowr mowthys of the holy sacrament. Furthermor, y charge yow that no man nother woman go to Godds borde lase than he be of ys synnys clen confessyd, & for hem contryte; that ys to sey hauyng sorow yn yowr herts, for yowre synnys. Furthermore, I charge yow yf ther be eny man or woman, that beryth yn his herte eny wrothe or rancor to eny of his evencristen [*fellow-Christian*] that he be not ther howselyd, ther to the tyme that he be with hym yn perfyte love & cheryte, for ho so [*whoso*] beryth wrethe or evyll wyll yn herte, to eny of hys evencristen, he ys note worthy hys God to receyue; and yf he do, he resevythe his dampnacyon, where he schuld receyue his saluacion. Furthermore, y charge yow that none of yow go to Godds borde to day, lasse than he be yn full wyll & purpose for to sese and to withstond the deds of syn. For who proposyth now to contynue yn syn azene after hys holy tyme he is note worthy to receyue his God; & yf he do hyt ys to hym grete perell. Furthermore I charge all strangers bothe men and women, that none of yow go to godds borde, yn to tyme that ze haue spoke with me, other [*or*] with myn asynys. Furthermore, y charge yow bothe men

See Hamlet v. 1.

the Holy Communion shall tarry still in the quire, or in some convenient place nigh the quire, the men on the one side and the women on the other side. All other (that mind not to receive the said Holy Communion) shall depart out of the quire, except the Ministers and Clerks." This implies that "the Ministers," i. e. the Deacon and Subdeacon, and the "Clerks," i. e. the Choristers, might remain in the quire, and others in the body of the church, during the celebration, even if not intending then to communicate.

This Exhortation, to be used at the time of the Communion, appears to be handed down in principle, and partly in words, from the habit of the unreformed Church of England. The old English form placed parallel to it¹ was evidently known, perhaps familiar, to those who wrote it; and the position of the Confession and Absolution at the end of it appears to indicate that the Reformers adopted no new system when they introduced these into our office in their present form, but simply remoulded what they found already in use.

Whether this was the general habit of the Church of England before the Reformation or not, certainly now one of the most

remarkable of the peculiar features of the Anglican Communion Offices is the anxious carefulness shown by the Church to ensure that communicants shall approach the Lord's Table after due preparation and with right dispositions. Not only in the previous notice, but in the course of the Service itself, they are warned of the danger of unworthy Communion, and the necessity of self-examination is insisted upon. The words of the Invitation are also very emphatic: "Ye that do *truly and earnestly* repent you of your sins." The lowly self-abasement of the general confession; the reminder that turning to Him "with *heartly* repentance and *true* faith" is the condition of God's forgiveness, and that our Saviour's "comfortable words" are addressed only to those who "*truly* turn to Him," are all of the same character. The admixture of grave warning and tender encouragement in this Service is indeed truly wonderful. There is nothing like it in the Offices of any other Communion, as (however others may be, in some features, grander and more striking) there is no Service more touchingly beautiful than the Communion Service of the Church of England, when performed as it ought to be. This peculiarity has probably conduced largely to the growth amongst us of a feeling, with respect to Holy Communion, which goes far to compensate for the almost universal neglect of the Church's

¹ Maskell's Mon. Rit. iii. 348.

Luke xxii. 19.
John xiii. 13.
xv. 13.
Eph. ii. 13, 18, 19.
1 John iii. 2.
1 Cor. xi. 23—25.
Luke xxii. 15, 17.
19, 20.
Ps. xliii. 4, 5.
cxvi. 13, 14.
cxliii. 10.
Heb. xiii. 15, 20,
21.
2 Cor. i. 3.
Rev. iv. 8.
Luke i. 74, 75.

great love of our Master, and only Saviour, Jesus Christ, thus dying for us, and the innumerable benefits which by his precious blood-shedding he hath obtained to us; he hath instituted and ordained holy mysteries, as pledges of his love, and for a continual remembrance of his death, to our great and endless comfort. To him therefore, with the Father and the Holy Ghost, let us give (as we are most bounden) continual thanks; submitting ourselves wholly to his holy will and pleasure, and studying to serve him in true holiness and righteousness all the days of our life. *Amen.*

¶ *Then shall the Priest say to them that come to receive the holy Communion,*

1 Cor. v. 7.
2 Cor. vii. 10, 11.
1 Cor. xiii. 4—7.
1 John iv. 7—11.
Rom. vi. 4, 6.
2 Cor. v. 14, 15.
17.
Mark x. 49.
Heb. x. 22.
1 Cor. x. 16.

YE that do truly and earnestly repent you of your sins, and are in love and charity with your neighbours, and intend to lead a new life, following the commandments of God, and walking from henceforth in his holy ways; Draw near with faith, and take this holy Sacrament to your comfort; and make your humble confession to Almighty God, meekly kneeling upon your knees.

¶ *Then shall this general confession be made, in the name of all those that are minded to receive the holy Communion, by one of the Ministers; both he and all the people kneeling humbly upon their knees, and saying,*

Rev. xv. 3, 4.
Acts xvii. 24, 28.
31.
Isa. lix. 12.
Amos v. 12.

ALMIGHTY God, Father of our Lord Jesus Christ, Maker of all things, Judge of all men; We acknow-

and women that have the servants, that ye take the heed that they be well y governed yn taking of mets & drynks, for the perell that may be fall, thorow forfeytyng of mets & drynks Also ye shall knell adown upon your kneys, seying after me, y cry God mercy, and our lady seynt mary, & all the holy company of hevyn, & my gostelyche fadyr, of all the trespasse of syn that y have don, in thowte, word, other [*or*] yn dede, fro the tyme that y was bore, yn to this tyme; that ys to say in Pryde, Envy, Wrethe, Slowthe, Covetyse, Gloteny, & Lechery. The v. Com-mawndements, dyuerse tymys y broke. The werks of mercy note y fulfyllid. My v. wyfts mysse spend, *etc.*

Misereatur vestri omnipotens Deus, etc.

Absolutionis forma.

Deus noster Jesus Christus, pro sua magna misericordia, *etc.*]

Μετὰ φόβου Θεοῦ, καὶ πίστεως, καὶ ἀγαπῆς προσέλθετε.

Liturgies of SS. James and Chrysostom.

¶ *His finitis, . . . accedat sacerdos cum suis ministris ad gradum altaris, et dicat ipse confessionem, diacono assistente a dextris et subdiacono a sinistris. Hoc modo incipiendo.*

Salisbury Use.

ALMIGHTY everlasting God, the Father of our Lord Jesus Christ, the Maker of all things, the Judge of

Daye's transl. of Hermann's Consult., A.D. 1547.

direction, that intending communicants should signify their names to the Curate beforehand, and to obviate the necessity of the Minister "repelling" any. For there is more risk of persons refraining who ought to communicate, than of persons communicating who ought to refrain.

It should be observed that the last paragraph forms a doxology, and ought to be said as such.

§ *The Invitation.*

The germ of this Invitation is to be observed in the above Exhortation of the Mediæval Church. It is first found, as it now stands, in the "Order of Communion" of 1548. It was no

doubt originally intended as an actual invitation, to those who were about to communicate, to leave the body of the congregation and pass into the chancel. The "Order of Communion" was an English appendix to the Latin Office, and the latter having been already completed, as far as the Communion of the Priest, the Invitation of course (with the Confession, Absolution, and Comfortable Words) followed the Consecration, instead of preceding it as now. It may be taken as a verbal substitute for the kiss of peace. Cosin suggested the words, "Draw near in full assurance of faith," probably with the view of indicating that the Invitation is now for an approach of the heart, not of the body. It should be read by the Celebrant.

Dan. ix. 5, 6.
Prov. xxiv. 9.
Matt. xii. 36, 37.
Luke xv. 18.
Deut. ix. 7.
Rom. ii. 8, 9.
Job vii. 20, 21.
xlii. 5, 6.
2 Cor. vii. 10, 11.
Ezek. xvi. 62, 63.
xxxvi. 31, 32.
Ps. xxxviii. 4.
li. 1.
Rom. iii. 24, 25.
1 John ii. 1, 2, 12.
Rom. vi. 4, 6, 13.
1 Thess. iv. 1.
2 Cor. v. 14, 15.
1 Tim. i. 17.

ledge and bewail our manifold sins and wickedness, Which we from time to time most grievously have committed, By thought, word, and deed, Against thy Divine Majesty, Provoking most justly thy wrath and indignation against us. We do earnestly repent, And are heartily sorry for these our misdoings; The remembrance of them is grievous unto us; The burden of them is intolerable. Have mercy upon us, Have mercy upon us, most merciful Father; For thy Son our Lord Jesus Christ's sake, Forgive us all that is past, And grant that we may ever hereafter Serve and please thee, In newness of life, To the honour and glory of thy Name; Through Jesus Christ our Lord. Amen.

¶ *Then shall the Priest (or the Bishop being present) stand up, and turning himself to the people, pronounce this absolution.*

Matt. vi. 14.
Isa. lv. 7.
John iii. 16.
2 Sam. xii. 13.
Acts x. 43.
Isa. xxx. 18.
Gal. i. 4.
1 Cor. i. 7, 8.
Eph. iii. 14.
1 Pet. v. 10, 11.

ALMIGHTY God, our heavenly Father, who of his great mercy hath promised forgiveness of sins to all them that with hearty repentance and true faith turn unto him; Have mercy upon you, pardon and deliver you from all your sins, confirm and strengthen you in all goodness, and bring you to everlasting life; through Jesus Christ our Lord. Amen.

all men, we acknowledge, and we lament that we were conceived and born in sins, and that therefore we be prone to all evils

Confiteor Deo, beatæ, quia peccavi nimis cogitatione, locutione, et opere: mea culpa

And we are sorry for it with all our hearts

Have mercy upon us, most gentle Father, through thy Son our Lord Jesus Christ

¶ *Et sciendum est, quod quicumque sacerdos Officium exsequatur, semper episcopus si presens fuerit, ad gradum altaris dicat Confiteor, Misereatur, et Absolutionem.*

BECAUSE our blessed Lord hath left this power to his congregation, that it may absolve them from sins, and restore them in to the favour of the heavenly Father, which being repentant for their sins, do truly believe in Christ the Lord

Misereatur vestri Omnipotens Deus et dimittat vobis omnia peccata vestra, liberet vos ab omni malo, conservet et confirmet in bono, et ad vitam perducat æternam. Amen.

THE CONFESSION AND ABSOLUTION.

From the ancient form of Exhortation given above, it will be seen that public confession and absolution before Communion were not a novelty when introduced into the Order of Communion of 1548, and subsequently into the full Communion Office of 1549. There was indeed a form of confession in the ancient office, (which will be found in the Appendix to the Liturgy, and at p. 5), yet this cannot be considered as the Confession of the people, but rather as that of the Celebrant and his Ministers. One was therefore used by the people before their too rare reception of the one element in ante-Reformation times, and this was methodized into its present form in 1548. It originally stood after the Consecration, and referred therefore to Communion only; but in 1552 it was placed in its present position, probably with the very reasonable and pious view that as "we are unworthy to offer any sacrifice" to God, so before we offer that sacrifice, the offering of which is our bounden duty, it is fit that we should make open confession of our unworthiness, and receive the benefit of Absolution. There is, indeed, an analogy between this and the washing of the disciples' feet by our Lord before the Institution. "Ye are clean," said He, when He had done this to them: or, as St. John records, "Now ye are clean through the word which I have spoken unto you." [John xvi. 3.]

So by the absolving word of God, even of "Our Lord Jesus Christ," Who hath power on earth to forgive sins, and "who hath left power to His Church to absolve all sinners who truly repent and believe in Him," all such may approach the solemn moment of Consecration, cleansed and prepared by the act of the Church, crowning their own penitence and confession.

The present position of the Confession and Absolution may thus be regarded as another recognition of the Priesthood of the Laity, and of the share which they have in the subsequent offering of the Eucharistic Sacrifice by their leader and representative who stands at the altar.

Both the Confession and Absolution owe some expressions to Hermann's Consultation, but there is no ground for supposing that the idea of them was taken from thence. Hermann's Confession is a long and homiletic kind of form, of which the only words at all similar to that of our Office are those given above. What slight association is traceable between the two, may be further seen by a reference to the note on the Absolution, in the "Order for the Visitation of the Sick."

Until 1661 the rubric directed the Confession to be said "in the name of those that are minded to receive the Holy Communion, either by one of them, or else one of the Ministers, or by the Priest himself." The Puritans objected to this, saying, "We desire it may be made by the Minister only," and that "it is a

¶ *Then shall the Priest say,*

Isa. xl. 1.
Matt. xiii. 9.
Rev. ii. 7.

Hear what comfortable words our Saviour Christ saith unto all that truly turn to him.

S. *Matt.* xi. 28. **C**OME unto me all that travail and are heavy laden, and I will refresh you.

S. *John* iii. 16. So God loved the world, that he gave his only-begotten Son, to the end that all that believe in him should not perish, but have everlasting life.

Hear also what S. Paul saith.

1 *Tim.* i. 15. This is a true saying, and worthy of all men to be received, That Jesus Christ came into the world to save sinners.

Hear also what S. John saith.

1 S. *John* ii. 1. If any man sin, we have an Advocate with the Father, Jesus Christ the righteous; and he is the propitiation for our sins.

¶ *After which the Priest shall proceed, saying,*

Lam. iii. 41.

Lift up your hearts.

Answer.

Ps. xxv. 1.
cxviii. 1.
cxlvii. 1.

We lift them up unto the Lord.

Priest.

1 Cor. xiv. 16.

Let us give thanks unto our Lord God.

Answer.

2 *Thess.* i. 3.

It is meet and right so to do.

Hear ye the Gospel. John iii.

GOD so loved the world that he gave his only-begotten Son, that all which believe in him, should have life everlasting.

Daye's transl. of
Hermann's Consult.,
A.D. 1547.

¶ *Or 1 Tim. i.*

This is a sure saying, and worthy of all embracing, that Jesus Christ came into this world to save sinners.

¶ *Or John iii.*

The Father loveth the Son, and hath given all things into his hands; he that believeth in the Son hath life everlasting.

¶ *Or Acts x.*

All the prophets bear witness unto Christ, that all that believe in him receive remission of their sins through him.

¶ *Or 1 John ii.*

My little children, if any have sinned, we have a just Advocate with the Father, Jesus Christ, and he is an atonement for our sins.

Sursum corda.

Salisbury Use.
All ancient Liturgies.

Habemus ad Dominum.

[Mozarab. *Liturgicus.*]

Gratias agamus Domino Deo nostro.

Dignum et justum est.

private opinion, and not generally received in the Catholic Church, that one of the people may make the Public Confession at the Sacrament, in the name of all those that are minded to receive the Holy Communion." Cosin altered the rubric to, "by one of the Ministers, or the Priest himself, both he and all the people kneeling humbly upon their knees, and saying." The Puritans apparently wished to prevent the people from saying it at all.

THE COMFORTABLE WORDS.

The use of these texts of Scripture is peculiar to the English Liturgy, and seems to have been derived from the Consultation of Archbishop Hermann. Before Communion and after Consecration the Liturgy of St. Mark directs the 42nd Psalm to be said, and that of St. James has the 23rd, 34th, 145th, and 116th in the same place. There is some analogy between this custom and our own, but it can scarcely be considered the precedent which led to the present usage.

Perhaps the object of their introduction was the obvious one suggested in the title of "comfortable words," that of confirm-

ing the words of Absolution with those of Christ and His Apostles; and of holding forth our Lord and Saviour before the communicants in the words of Holy Scripture to prepare them for "discerning" His Body in the Sacrament.

THE PREFACE.

This portion of the Communion Office is found almost word for word in every known Liturgy, in every part of the Catholic Church, from the earliest times; and there can be no doubt that it is a correct tradition which assigns it to the Apostolic age.

The originals are here given from the Ancient Greek Liturgies. *"Ανω σχῶμεν τὰς καρδίας. Ἐρχομεν πρὸς τὸν Κύριον. Εὐχαριστήσωμεν τῷ Κυρίῳ. Ἄξιον καὶ δίκαιον. Ἀληθῶς ἄξιόν ἐστι καὶ δίκαιον, πρέπον τε καὶ ὀφειλόμενον, σὲ αἰνεῖν, σὲ ὑμνεῖν, σὲ εὐλογεῖν, σὲ προσκυνεῖν, σὲ δοξολογεῖν, σοὶ εὐχαριστεῖν.* [St. James.] *Δέσποτα Κύριε Θεέ, Πάτερ παντοκράτωρ.* [St. Mark.] *Ὡς ἡμεῖς οἱ οὐρανοὶ τῶν οὐρανῶν, καὶ πάντα ἡ δύναμις αὐτῶν . . . ἄγγελοι, ἀρχάγγελοι* [St. James], &c. at much greater length than in the Western Prefaces . . . *"Αγιος, ἅγιος, ἅγιος Κύριε Σαβαώθ, πλήρης*

¶ Then shall the Priest turn to the Lord's Table, and say,

Ps. xxix. 2.
Heb. xiii. 15.
Ps. xxxiv. 1.
Eph. v. 20.
Rev. xix. 5, 6.

These words [Holy Father] must be omitted on Trinity Sunday.

IT is very meet, right, and our bounden duty, that we should at all times, and in all places give thanks unto thee, O Lord, Holy Father, Almighty, Everlasting God.

¶ Here shall follow the proper Preface, according to the time, if there be any specially appointed: or else immediately shall follow,

Isa. vi. 2.
Rev. iv. 8.
Rev. vii. 9—12.
Luke ii. 13, 14.
Heb. xii. 22, 23.
Isa. vi. 3.
Ps. xcvi. 6.
I Chron. xxix. 10—18.
Ps. lxxii. 18, 19.

THEREFORE with Angels and Archangels, and with all the company of heaven, we laud and magnify thy glorious Name; evermore praising thee, and saying, Holy, holy, holy, Lord God of hosts, heaven and earth are full of thy glory. Glory be to thee, O Lord most High. *Amen.*

VERE dignum et justum est, æquum et salutare, nos tibi semper et ubique gratias agere, Domine Sancte, Pater Omnipotens, æterne Deus.

¶ Sequuntur Præfationes.

ET ideo cum Angelis et Archangelis, cum thronis et dominationibus, cumque omni militia cœlestis exercitus, hymnum gloriæ tuæ canimus, sine fine dicentes:

Sanctus, Sanctus, Sanctus, Dominus Deus Sabaoth. Pleni sunt cœli et terra gloria tua: Osanna in excelsis. Benedictus qui venit in nomine Domini: Osanna in excelsis.

ὁ οὐρανὸς, καὶ ἡ γῆ τῆς δόξης σου. Ὁσαννὰ ἐν τοῖς ὑψίστοις. εὐλογημένοι ὁ ἐρχόμενος ἐν ὀνόματι Κυρίου Ὁσαννὰ ἐν τοῖς ὑψίστοις. [St. James.]

It seems more than probable that this long thanksgiving prayer (the *εὐχαριστία ἐπὶ πολλῷ* of Justin Martyr, Apol. i. ch. 86), which, beginning with the *Sursum Corda*, included also the Invocation of the Holy Spirit, the recitation of the Words of Institution, and the Prayer of Oblation, and closed with the Lord's Prayer, is alluded to by St. Paul, in "Else when thou shalt bless with the Spirit, how shall he that occupieth the room of the unlearned say Amen at thy giving of thanks [*ἐπὶ τῆ σῆ εὐχαριστίᾳ*], seeing he understandeth not what thou sayest?" [1 Cor. xiv. 16.]

The "*Sursum Corda*" is referred to by St. Cyprian, in his treatise on the Lord's Prayer [A.D. 252], where he says, "It is for this cause that the Priest before worship uses words of introduction, and puts the minds of the brethren in preparation, by saying, 'Lift up your hearts;' that while the people answer, 'We lift them up unto the Lord,' they may be reminded that there is nothing for them to think of except the Lord." [Cyp. de Orat. 20.] St. Cyril of Jerusalem, a century later, also comments upon them in these terms: "After this the Priest cries aloud, 'Lift up your hearts.' For truly ought we in that most awful hour to have our heart on high with God, and not below, thinking of earth and earthly things. The Priest then, in effect, bids all in that hour abandon all worldly thoughts, or household cares, and to have their heart in heaven with the merciful God. Then ye answer, 'We lift them up unto the Lord;,' assenting to him by your avowal. . . . Then the Priest says, 'Let us give thanks to the Lord.' For in good sooth are we bound to give thanks, that He has called us, unworthy as we are, to so great grace; that He has reconciled us who were His foes; that He has vouchsafed to us the spirit of adoption. Then ye say, 'It is meet and right;' for in giving thanks we do a meet thing and a right; but He did, not a right thing, but what was more than right, when He did us good, and counted us meet for such great benefits." [Cyril. Catech. Lect. xxiii. 3, 4.] These versicles are also referred to by St. Chrysostom [de Euch., de Penitentia], by St. Augustine [de Dono Perseverant. xiii.], and by Cæsarius of Arles [Hom. xii. xvi.].

The use of the Sanctus is of equally ancient date. St. Cyril speaks of its long Preface in a passage following that just quoted, and then goes on to say: "We make mention also of the Seraphim, whom Isaiah, by the Holy Ghost, beheld encircling the

throne of God, and with two of their wings veiling their countenances, and with two their feet, and with two flying, who cried, 'Holy, Holy, Holy, Lord God of Sabaoth.' [Isa. vi. 1. Rev. iv. 8.] For this cause, therefore, we rehearse this confession of God, delivered down to us from the Seraphim, that we may join in hymns with the hosts of the world above."

It is very remarkable that in all the Ancient Liturgies, both of East and West, the saying of the Sanctus is given to the choir and people. The Celebrant having recited the Preface, or Introductory part of this great act of Eucharistic Thanksgiving, the "Triumphal Hymn" itself, as the Liturgies of St. Basil and St. Chrysostom call it, is taken up by the whole body of the worshippers who, as kings and priests unto God, join in that solemn act of adoration of the ever-blessed Trinity. To mark this Catholic custom the Sanctus itself ought to be printed as a separate paragraph, and so it was printed in 1549 and 1552. In choirs, and places where they sing, both it and the *Gloria in Excelsis* ought always to be sung in the same manner as the Creed. In this our highest, most glorious, and most joyous service our highest efforts ought to be used to make it as worthy as we can of Him to whom it is offered, and to bring out as fully as we can its character of adoring thanksgiving.

In the Primitive and Mediæval Liturgies the Sanctus concluded with the words, "Hosanna in the Highest, blessed is He that cometh in the Name of the Lord, Hosanna in the highest." In translating it for the Office of our Prayer Book, the four latter words were changed to "Glory to Thee, O Lord, in the highest;" and the present termination was substituted in 1552, thus displacing the Hosanna altogether.

No reason can be assigned for this deviation from ancient custom¹. But there was, perhaps, some popular superstition, now lost sight of, which made it seem desirable to drop the words in question. The Mirror of our Lady [A.D. 1530] comments upon the Sanctus as then used in the following words: "This song Sanctus is the song of Angels, and it is said to the Blessed Trinity, as is said before in the hymn *Te Deum* at Mattins. The second part thereof, that is, *Benedictus*, is taken from the Gospel, where the people on Palm Sunday came against our Lord Jesus Christ, and said to Him the same words in

¹ In the Clementine Liturgy, however, the Sanctus and the Hosanna are placed separate, and at a considerable distance from each other.

¶ PROPER PREFACES.

¶ Upon Christmas day, and seven days after.

Luke ii. 14, 11.
John i. 14.
Matt. i. 20, 21.
Luke i. 35.
1 Pet. ii. 22.
Heb. vii. 26.
2 Cor. v. 21.
1 Tim. i. 17.

BECAUSE thou didst give Jesus Christ thine only Son to be born as at this time for us; who by the operation of the Holy Ghost was made very man of the substance of the Virgin Mary his mother, and that without spot of sin, to make us clean from all sin. Therefore with Angels, &c.

¶ Upon Easter day, and seven days after.

1 Pet. i. 3.
1 Cor. xv. 19, 20.
Exod. xii. 3—14.
1 Cor. v. 7.
John i. 29.
Heb. ii. 14, 15.
1 Cor. xv. 55, 57.
John vi. 47.
Rev. v. 12.

BUT chiefly are we bound to praise thee for the glorious Resurrection of thy Son Jesus Christ our Lord: for he is the very Paschal Lamb, which was offered for us, and hath taken away the sin of the world; who by his death hath destroyed death, and by his rising to life again hath restored to us everlasting life. Therefore with Angels, &c.

¶ Upon Ascension day, and seven days after.

Eph. v. 20.
Matt. iii. 17.
Luke xxiv. 50, 51.
Acts i. 2—4, 9.
John xiv. 2, 3.
John xvii. 24.
Col. iii. 1—4.
Rev. i. 5, 6.

THROUGH thy most dearly beloved Son Jesus Christ our Lord; who after his most glorious Resurrection manifestly appeared to all his Apostles, and in their sight ascended up into heaven to prepare a place for us; that where he is, thither we might also ascend, and reign with him in glory. Therefore with Angels, &c.

¶ Upon Whitsunday, and six days after.

John xiv. 16, 26.
John xvi. 26.
Acts ii. 1—4.

THROUGH Jesus Christ our Lord; according to whose most true promise, the Holy Ghost came down as at this time from heaven with a sudden great sound, as it had been a mighty wind, in the likeness of fiery

PREFATIONES.

Hæc præfatio dicitur in die Nativitatis Domini Salisbury Use.
... *et quotidie per hebdomadam, et in die Circumcisionis.*

Sequens Præfatio dicitur in die Paschæ et per totam hebdomadam . . .

ET te quidem omni tempore, sed in hac potissimum die gloriosius prædicare, cum Pascha nostrum immolatus est Christus. Ipse enim verus est agnus qui abstulit peccata mundi, qui mortem nostram moriendo destruxit, et vitam resurgendo reparavit. Et ideo cum angelis, &c.

Sequens Præfatio dicitur in die Ascensionis Domini, et per octavas, et in octavis, et in Dominica infra octavas . . .

PER Christum Dominum nostrum, Qui post resurrectionem suam omnibus discipulis suis manifestus apparuit, et ipsis cernentibus est elevatus in cælum, ut nos divinitatis suæ tribueret esse participes. Et ideo cum angelis, &c.

Sequens Præfatio dicitur in die Pentecostes et per hebdomadam . . .

praising and joying of His coming. And so they are sung here in the mass, in worship of our Lord's coming in the Sacrament of the Altar. And therefore at the beginning of *Benedictus* ye turn to the altar and make the token of the Cross upon you in mind of our Lord's Passion, which is specially represented in the Mass." [Mirror, f. cxxxviii.] It is not unlikely that the last period of this comment gives an indication of the reason why the change was made. A more satisfactory explanation that may be given, however, is that the *Benedictus* is not part of the song of the angels, and is therefore inconsistent, strictly speaking, with the words of the Preface.

The presence of angels at the celebration of the Holy Communion has been a pious belief of the Church from Primitive times, and in all parts of the Christian world. [See 1 Cor. xi. 10.]

§ Proper Prefaces.

Besides these five proper Prefaces, the Sarum Missal had one for Epiphany and seven days after, one for Ash-Wednesday and Ferial days in Lent, one for Festivals of Apostles or Evangelists, and one for the Festivals of the Blessed Virgin. The Trinity Preface was used on all the Sundays after Trinity, and at every

John xvi. 13.
Acts ii. 7.
iv. 5, 6, 13.
Rom. xv. 16, 19.
x. 18.
2 Cor. iv. 6.
1 Pet. i. 10, 12.
Luké i. 67, 78, 79.
John xvii. 3.

tongues, lighting upon the Apostles, to teach them, and to lead them to all truth; giving them both the gift of divers languages, and also boldness with fervent zeal, constantly to preach the Gospel unto all nations; whereby we have been brought out of darkness and error into the clear light and true knowledge of thee, and of thy Son Jesus Christ. Therefore with Angels, &c.

¶ Upon the Feast of Trinity only.

Deut. vi. 4.
Mark xii. 32.
Matt. xxviii. 19.
Acts x. 48.
2 Cor. xiii. 14.
Numb. vi. 24—26.
Isa. vi. 3.
1 Tim. i. 17.

WHO art one God, one Lord; not one only Person, but three Persons in one Substance. For that which we believe of the glory of the Father, the same we believe of the Son, and of the Holy Ghost, without any difference or inequality. Therefore with Angels, &c.

¶ After each of which Prefaces shall immediately be sung or said,

THEREFORE with Angels and Archangels, and with all the company of heaven, we laud and magnify thy glorious Name; evermore praising thee, and saying, Holy, holy, holy, Lord God of hosts, heaven and earth are full of thy glory: Glory be to thee, O Lord most High. Amen.

¶ Then shall the Priest, kneeling down at the Lord's Table, say in the name of all them that shall receive the Communion this Prayer following.

Gen. xviii. 27.
Dan. ix. 18.
Luke xviii. 13.
Ps. v. 7.
Heb. iv. 14—16.
Gen. xxxii. 10.
Luke vii. 6, 7.

WE do not presume to come to this thy Table, O merciful Lord, trusting in our own righteousness, but in thy manifold and great

Sequens Præfatio dicitur in die Sanctæ Trinitatis [et in omnibus Dominicis usque ad Adventum Domini . . .] Salisbury Use.

QUI cum unigenito Filio Tuo et Spiritu Sancto unus es Deus, unus es Dominus, non in unius singularitate Personæ, sed in unius Trinitatæ Substantiæ. Quod enim de tua gloria revelante te credimus, hoc de Filio tuo, hoc de Spiritu Sancto, sine differentia discretionis sentimus . . . una voce dicentes.

Salisbury Use.
Greg. Gelas.

¶ Item in aliis Præfationibus conclusio.

ET ideo cum Angelis et Archangelis, cum thronis et dominationibus cumque omni militia cœlestis exercitus, hymnum gloriæ tuæ canimus, sine fine dicentes:

Sanctus, Sanctus, Sanctus, Dominus Deus Sabaoth, pleni sunt cœli et terra gloria tua; Osanna in excelsis; benedictus qui venit in nomine Domini; Osanna in excelsis.

Oremus.

DOMINE, sancte Pater, omnipotens, æterne Deus, da nobis hoc corpus et sanguinem Filii tui Domini Dei nostri Jesu Christi ita sumere, ut

York Use.
Salisbury Use.
Greg. ap. Meuard.
p. 265.

wedding celebration. The Liturgies of the Eastern Church have but one invariable Preface, much longer and fuller than those of the West, throughout the year. In the Latin Church the variety of Prefaces was anciently much greater than it is now. The Sacramentaries of SS. Leo, Gelasius, and Gregory, which have been the great sources of liturgical forms for all the Churches of the West, contain a Preface for nearly every Sunday and Festival throughout the year. The same is true of the Mozarabic Missal, in which the Preface is called "Illatio," and of the ancient Gallican Liturgies, whose name for it is "Contestatio." The number was reduced to ten about the end of the twelfth century, in the English, and in all other Western Missals but the Ambrosian and the Mozarabic. The ancient Missals always contained the musical

notation of the various Prefaces as well as of the Creed, and the Lord's Prayer; and the Intonation of the Gloria in Excelsis.

§ *The Prayer of Humble Access.*

This Prayer, together with the Invitation, "Ye that do truly," the Confession, Absolution, and Comfortable Words, which it then immediately followed, was placed in the Liturgies of 1548 and 1549 between the Consecration and the Communion. It is similarly placed in the Scottish Liturgy of 1637; and in the present Scottish Office. Archbishop Laud says: "If a comparison must be made, I do think the order of the Prayers as they now stand in the Scottish Liturgy to be the better and more

Rom. x. 12.
Ps. c. 5.
Heb. xii. 28.
John vi. 53—58.
1 Cor. vi. 11.
Heb. ix. 13, 14.
Rev. vii. 14.
John vi. 34.

mercies. We are not worthy so much as to gather up the crumbs under thy Table. But thou art the same Lord, whose property is always to have mercy: Grant us therefore, gracious Lord, so to eat the flesh of thy dear Son Jesus Christ, and to drink his blood, that our sinful bodies may be made clean by his body, and our souls washed through his most precious blood, and that we may evermore dwell in him, and he in us. *Amen.*

¶ *When the Priest, standing before the Table, hath so ordered the Bread and Wine, that he may with the more readiness and decency break the Bread before the people, and take the Cup into his hands, he shall say the Prayer of Consecration, as followeth.*

mereamur per hoc remissionem peccatorum nostrorum accipere et tuo sancto Spiritu repleti: quia tu es Deus, et præter te non est alius nisi tu solus. Qui vivis et regnas Deus.

agreeable to use in the Primitive Church; and I believe they which are learned will acknowledge it." The change was made in 1552, and like some others made at the same time is difficult to account for, except on the ground of some temporary influence and danger. In the Liturgies of 1548 and 1549, after "drink His blood" was added "in these holy mysteries," which words were omitted in 1552, and proposed for restoration by Cosin. In the Eastern Liturgies the Prayer which answers to this is called the Prayer of Inclination, and is said immediately before the Communion of the People.

In the Salisbury Missal this Prayer was said in the singular number; but the York Missal had it in the plural as given above.

The emphatic sense of "so to eat" must not be overlooked in the use of this Prayer. The sense of it may be best seen by a paraphrase:—"We are not worthy to gather up the crumbs under Thy Table, but of Thy mercy Thou dost grant us the flesh, and blood of Thy dear Son: Grant us so to eat and drink that precious Gift that His promise may be altogether fulfilled, that we may eat and drink of these after the manner of those to whom He is Life unto Life; and not after the manner of those to whom the WORD of Life Itself is Death unto Death."

Bishop Cosin proposed to place this Prayer immediately before the Communion: the reasons already given for the place of the Confession and Absolution seem, however, to justify its retention here.

THE PRAYER OF CONSECRATION¹.

This is the central portion of the "Canon of the Mass" as it was rendered in the English Liturgy of 1549. The original form

¹ The manner in which Bishop Cosin desired to restore the ancient mode of Consecration and Oblation may be best seen by printing his marginal alterations in their proper order. A comparison of these with the Offices of 1549 and 1637, as printed in the Appendix, will give a complete view of this Prayer.

"Here followeth the Prayer of Consecration—

"When the Priest, standing before the Table, hath so ordered the Bread and Wine that he may with the more readiness and decency break the Bread before the people, and take the Cup into his hands, he shall say as followeth,

"Almighty God, our heavenly Father, who . . . His precious death and sacrifice . . . we most humbly beseech Thee, and by the power of Thy holy word and Spirit, vouchsafe so to bless and sanctify these Thy gifts and creatures of Bread and Wine, that we receiving them according to Thy Son . . . in remembrance of Him, and to show forth His death and passion, may be partakers of His most blessed Body and Blood.

"Who in the same night that He was betrayed * took Bread, and when He had blessed, and given thanks He brake it and gave it to His disciples, saying, Take,

* At these words [took Bread] the priest is to take the Paten into his hands: at [brake it] he is to break the Bread: and at [this is My Body] to lay his hand upon it. At the words [took the Cup] the priest

of the whole will be found in the Appendix to the Communion Office.

When the Priest, standing before the Table] In the Prayer Book of 1552, the rubric merely directs the Priest, after saying the Prayer of humble access "kneeling down at God's Board," to say the Prayer of Consecration standing up. In the Scottish Book of 1637, the rubric is:—"Then the Presbyter, standing up, shall say the Prayer of consecration as followeth; but then during the time of consecration he shall stand at such a part of the holy table, where he may with the more ease and decency use both his hands." The natural meaning of the present rubric is that the Celebrant, who, during the Prayer of humble access, has been "kneeling down at the Lord's Table," shall now stand "before" it, i. e., at the middle of its front, facing east, and having "so ordered the Bread and Wine," &c., shall, *without changing his position* (for which there is no direction), "say the Prayer of Consecration." The phrase "before the people" means, not turning towards them, but (1) In front of, at the head of them, as their representative and spokesman. (2) In full view of them, in the one place where he can best be seen by all present. The action of turning round, or half round, to the people, holding the Paten in the left hand, and breaking the Bread with the thumb and forefinger of the right hand, is quite unjustified by the rubric, and a kind of action very unsuitable to the solemn dignity with which this part of the Office should be invested.

eat, this is My Body which is given for you, doe this in remembrance of Me.

"Likewise, after supper, he took the Cup, and when He had blessed and given thanks He gave it to them, saying, Drink ye all of this: for this is My Blood of the New Testament, which is shed for you, and for many for the remission of sins, do this as oft as ye shall drink it in remembrance of Me. *Amen.*

is to take the Chalice into his hands: and at [this is My Blood] to lay his hand upon every vessel [be it Chalice or Flagon] in which there is wine to be consecrated.

"Immediately after shall follow this Memorial, or Prayer of Oblation.

"Wherefore, O Lord and heavenly Father, according to the Institution of Thy dearly beloved Son, our Saviour Jesus Christ, we Thy humble servants do celebrate, and make here before Thy divine Majesty, with these Thy holy gifts, the memorial which Thy Son hath willed and commanded us to make: having in remembrance His most blessed passion and sacrifice, His mighty resurrection, and His glorious ascension into heaven, rendering unto Thee most hearty thanks, for the innumerable benefits procured unto us by the same, and we entirely desire Thy fatherly goodness, mercifully to accept this our Sacrifice of praise and thanksgiving: most humbly beseeching Thee to grant, that by the merits and death of Thy Son Jesus Christ, now represented unto Thee, and through faith in His Blood who maketh intercession for us at Thy right hand, we and all Thy whole Church may obtain remission of our sins, and be made partakers of all other benefits of His Passion. And here we offer and present unto Thee, O Lord, ourselves our souls and bodies." [As in 1549. See Appendix.]

Ps. cxix. 156.
Rom. v. 8.
Acts iii. 18.
Eph. i. 7.
Gal. iii. 13.
Isa. liii. 10.
Heb. vii. 27.
ix. 28.

x. 10—14. 26.
Acts iv. 12.
1 John ii. 1, 2.
Luke xxii. 19, 20.
1 Cor. xi. 23—26.
28.

1 Cor. x. 16, 17.
Luke xxii. 19, 20.

(a) *Here the Priest is to take the Paten into his hands:*
(b) *And here to break the bread:*

AL MIGHTY God, our heavenly Father, who of thy tender mercy didst give thine only Son Jesus Christ to suffer death upon the Cross for our redemption; who made there (by his one oblation of himself once offered) a full, perfect, and sufficient sacrifice, oblation, and satisfaction, for the sins of the whole world; and did institute, and in his holy Gospel command us to continue, a perpetual memory of that his precious death, until his coming again; Hear us, O merciful Father, we most humbly beseech thee; and grant that we receiving these thy creatures of bread and wine, according to thy Son our Saviour Jesus Christ's holy institution, in remembrance of his death and passion, may be partakers of his most blessed Body and Blood:

who, in the same night that he was betrayed, (a) took Bread; and, when he had given thanks, (b) he brake it, and gave it to his disciples, saying, Take,

O GOD heavenly Father, which of thy tender mercy didst give thine only Son Jesu Christ, to suffer death upon the cross for our redemption; who made there (by his one oblation once offered) a full, perfect, and sufficient sacrifice, oblation, and satisfaction, for the sins of the whole world; and did institute, and in his holy Gospel command us to celebrate a perpetual memory of that his precious death, until his coming again: hear us, (O merciful Father,) we beseech thee; and with thy Holy Spirit and word vouchsafe to bless and sanctify these thy gifts and creatures of bread and wine.

... ut nobis corpus et sanguis fiat dilectissimi Filii tui Domini nostri Jesu Christi.

Qui pridie quam pateretur, accepit panem in sanctas ac venerabiles manus suas, et elevatis oculis in cœlum ad Te Deum Patrem suum Omnipotentem,

Here the Priest] The marginal rubrics for the manual rites were omitted in the Revision of 1552. The two directing the Priest to take the Bread, and then the Wine, into his hands, were restored in 1661, and the other three directing the Breaking of the Bread, and the laying of the hand on the Bread, and on the Wine, were then first inserted. In the case of the first marginal rubric there is a needless and awkward change from that of 1549. It is the Bread, not the Paten, the Priest should take into his hands. If he takes the Paten, he must certainly put it down again before he can conveniently comply with the next direction.

And here to break the Bread] The breaking the Bread before consecration, though apparently "most agreeable with the institution of Christ," is peculiar to the English Rite. In all other Liturgies it occurs after the Consecration, usually after the Lord's Prayer, with which the long Consecration Prayer invariably closes, and shortly before the dipping of a portion into the cup before actual communion, a rite which is found in all the great Liturgies of East and West. The laying of the right hand on each element during the utterance of the words of consecration is also peculiar to the English Rite. It seems to come most nearly in the place of the act of making the sign of the cross, which in the unreformed Use the Celebrant did as he said the word *benedixit* over each element.

that we receiving these thy creatures of bread and wine] In this place the Invocation of the Holy Ghost was inserted in 1549. This occurs in every ancient Catholic Liturgy of both East and West, excepting only the Roman, and those derived from it (if indeed the Roman or Petrine family of Liturgies did not itself also originally contain it), and the Holy orthodox Church of the East has always thought it essential to the act of consecration. It was omitted in 1552, probably in deference to the scruples of Bucer. It was inserted in the Scottish Book of 1637, and forms part of the existing Scottish and American Communion Offices, where it follows the Words of Institution and the Prayer of Oblation, as in the Eastern Liturgies. The clause in our present Office contains an implied or oblique invocation of the Holy Ghost, since it is only through His divine operation that we, by receiving God's "creatures of Bread and Wine," can "be

made partakers of Christ's most blessed Body and Blood." But we may be allowed to wish, with Bishops Horsley and Wilson, and the best informed English Divines, that the direct Invocation had been left untouched.

§. The Words of Institution.

The whole Western Church has always held that the Consecration of the Holy Eucharist is effected and completed by the recitation of our Lord's words of Institution¹. They are of such solemn importance, as bringing our Lord Himself in to be the Consecrator of the Holy Sacrament, that they should be uttered with deliberation and distinctness, the Celebrant taking ample time for the manual gestures. Bishop Cosin marked off as separate paragraphs the words beginning, "Who in the same night," and "Likewise after Supper:" and it is much to be wished that this mode of printing the prayer was adopted. The Sarum rubric for the pronunciation of the words "Hoc est enim corpus meum" is as follows:—"Et debent ista verba proferri cum uno spiritu et sub una prolatione, nulla pausatione interposita."

Previously to the words "blessed and brake," the Liturgies of St. Mark, St. James, St. Clement, and that of Malabar, and all the great Western Liturgies, except the Mozarabic, insert that "our Lord looked up to Heaven," and the Sarum and Roman Liturgies direct the Celebrant to lift up his eyes to Heaven. This is not mentioned in the Gospel accounts of the Institution, though our Lord may well have done so, as it is mentioned He did in blessing the bread at the Feeding of the Five Thousand, and tradition may have preserved it. The Liturgies of St. Basil and St. Chrysostom do not notice it. After "given thanks" all the ancient English Liturgies, the Roman, Ambrosian, and Mozarabic, the Liturgies of St. Mark, and St. Basil, and of Malabar, insert "He blessed," both for the Bread and the Cup; the Liturgy of St. James and the Clementine for the Cup only; and the Liturgy of St. Chrysostom for the Bread only.

he brake it] There cannot be too great exactness and reverent formality on the part of the Celebrant in consecrating the

¹ On this subject see Neale's *Introd. to Hist. of the Holy Eastern Church* II. v. 9; and Freeman's *Princ. Div. Serv.* II. ii. pp. 190—199.

(c) *And here* eat, (c) this is my Body which is given to lay his hand upon all the bread.

(d) *Here he is* to take the cup into his hand:

(e) *And here* to lay his hand upon every vessel (be it Chalice or Flagon) in which there is any wine to be consecrated. ye shall drink it, in remembrance of me. Amen.

Matt. xxvi. 27, 28.

Tibi gratias agens benedixit, fregit, [*Hic tangat hostiam dicens*] deditque discipulis suis, dicens, Accipite et manducate ex hoc omnes.

Hoc est enim corpus meum.

Simili modo posteaquam cœnatum est, accipiens et hunc præclarum calicem in sanctas ac venerabiles manus suas, item Tibi gratias agens, benedixit, deditque discipulis suis, dicens Accipite et bibite ex eo omnes. [*Hic elevet parumper calicem, ita dicens,*]

Hic est enim calix sanguinis mei novi et æterni testamenti, mysterium fidei, qui pro vobis et pro multis effundetur in remissionem peccatorum.

elements by means of which, when consecrated, an acceptable sacrifice is to be carried up to the Father, and the Body and Blood of the Lord Jesus Christ received by the communicants. The Priest having, therefore, taken the Bread into his hands at the words "took bread," should raise his hands in front of his breast, break the Bread by separating it into two portions, and then hold the separated portions one in each hand in such a manner that they may be visible to the communicants. He should then replace the fragments on the Paten, take the Paten in his left hand, and hold his right hand over it whilst saying the words, "This is My Body which is given for you." He should then raise the Paten slightly in both hands, and, bowing his head, hold it in front of him whilst saying the words, "Do this in remembrance of Me," and then replace it on the Altar and cover it. Similarly after the Consecration of the Wine he should raise the Chalice slightly in both hands, and hold it in front of him whilst saying the words of Consecration, and then replace and cover it¹.

This is the most solemn part of the whole ministration of the Liturgy. Standing before the flock of Christ in the Presence of Almighty God, the Priest stands there as the vicarious earthly representative of the invisible but one true and only Priest of the Heavenly Sanctuary: acting "in His Name," and "by His commission and authority" [Article xxvi.], he brings into remembrance before the Eternal Father the one only and everlasting Sacrifice which was once for all made and "finished upon the Cross" [Article xxxi.], but is perpetually pleaded, offered, and presented, by the One Everlasting Priest and Intercessor in Heaven. For Christ as our Great High Priest, Who "ever liveth to make intercession for us," and Who is the ever-acceptable Victim and Propitiation for our sins, doeth indeed no more that which He pronounced to be "finished" on Calvary, but evermore pleadeth for our sake that which then He did. And this He does in two ways. (1) In Heaven, openly, as one may say, and by His own immediate action. (2) On Earth, mystically, but as really, acting mediately by the earthly Priest as His visible instrument. The Action is the same in both cases, and the real Agent is the same; for Christ, since Pentecost, is as really (though supernaturally and spiritually) present on earth, in and by the ordinances of His own Institution, as He is since the Ascension in Heaven naturally and corporally. "Where two or three are gathered together in His name," (and where so truly are we so gathered as when we meet to celebrate the great Memorial Sacrifice specially appointed by Himself?) "there is He in the midst of us;" not so much as the acceptor (for such is

sometimes mistaken to be the only meaning of this text) as the leader and offerer of our worship, invisibly acting through His visible instrument, and representative. The great and only Sacrifice once made can never be repeated. But it is continually offered, i. e., brought into remembrance and pleaded, before God. They who are called "Priests" because, and only because, they visibly represent to the successive generations of mankind the one immortal but invisible Priest, are through God's unspeakable mercy privileged to bring it into remembrance before Him, by His order, Who said, "Do this for a Memorial, a Commemoration of Me." Thus the Priest's action in offering our Christian Sacrifice may be described (1) as the earthly counterpart of that which Christ continually does in Heaven: (2) as the commemoration of that which, once for all, He did on Calvary. The Priest makes the Oblation actually and verbally when he says the words, "Do this," &c., and afterwards verbally, and with greater fulness, in the "Prayer of Oblation" which follows the actual communion².

[Amen] But although the celebrating Priest stands thus before God offering up to Him this holy Oblation, he does it in company with all the faithful, at whose head he stands. And to signify their co-operation with him in his great act, they say "Amen" to his Eucharistic words and acts, adopting them as their own. On this point a venerated writer of our own day has written as follows:—

"It is the unquestionable doctrine both of the Old and New Testament, that, without prejudice to the special official Priesthood of the sons of Aaron in the one dispensation, and the successors of the Apostles in the other, all the people of God, with the true Melchizedec at their head, are 'a kingdom of Priests, a royal priesthood,' and every one is a 'king and priest unto the Father, to offer up spiritual sacrifices acceptable to God by Jesus Christ.' None may doubt that the chief of those spiritual sacrifices is that which causes all the rest to be acceptable,—Christ Himself offered up to the Father by the offering of His Body and Blood in the Holy Communion. Accordingly, the Christian people have been instructed from the beginning to take their part in that offering, by the solemn Amen especially, wherewith they have always responded to the Prayer of Consecration. There is hardly any point of our ritual which can be traced more certainly than this to the very Apostolic times. Every one will remember St. Paul's saying, 'When thou shalt bless with the Spirit, how shall he that occupieth the room of the unlearned say Amen at thy giving

¹ Covers were provided for Chalices during the seventeenth and eighteenth centuries, but Chalice veils of linen are now generally used.

² On the Eucharistic Sacrifice, see Hicke's "Christian Priesthood," Johnson's "Unbloody Sacrifice," the Bishop of Brechin's "Theological Defence," pp. 10—80, 104; Keble's "Eucharistical Adoration," II. 36, &c. Many more works might be named, but these are comparatively accessible to the theological student. See also the Introduction to the Communion Office, p. 152 of this work.

¶ *Then shall the Minister first receive the Communion in both kinds himself, and then pro-*

[*Ad corpus dicat cum humilitatione antequam [Salisbury Use.] percipiat.*]

of thanks, seeing he understandeth not what thou sayest? [1 Cor. xij. 16]—words which, in a singular way, bear witness both to the share (*τόρος*) which all Christians have in the priesthood of Melchizedec, and to the distinction which nevertheless exists between those who might bless, and laymen (*ιδιώται*) who were not permitted to do so. . . . Justin Martyr mentions the 'Amen' uttered by the people at the end of the Consecration as a special circumstance of the Christian Eucharist." Tertullian, St. Chrysostom, and St. Ambrose also all expressly allude to the emphatic response of "Amen" at the close of the Consecration Prayer.

THE COMMUNION¹.

Then shall the Minister first receive] There is no express direction as to the posture of the Celebrant himself in receiving, unless (which seems hardly likely) the words "all meekly kneel-

¹ The alterations proposed by Bishop Cosin after the Prayer of Consecration are here given as they stand in his Durham Book:

Then shall the Priest, that celebrateth, receive the Holy Communion in both kinds upon his knees, and when he taketh the Sacrament of the Body of Christ, he shall say,

The Body of our Lord Jesus Christ, which was given for me, preserve my body and soul unto everlasting life. Amen. I take and eat this for the remembrance of Christ who died for me, and I feed on Him in my heart by faith with thanksgiving.

And when he taketh the Sacrament of Christ's Blood, he shall say,

The Blood of our Lord, which was shed for me, preserve my body and soul into everlasting life. Amen. I drink this for the remembrance of Christ who shed His blood for me, and am thankful.

Then shall he stand up and proceed to deliver the Holy Communion, first to the Bishops, Priests, and Deacons, (if any be present,) in both kinds: and after to the people in due order, into the hands of all humbly kneeling and so continuing, as is most meet, at their devotions and prayers unto the end of the whole Communion.

And when he delivereth the Sacrament of the Body of Christ to any one he shall say,

The Body of our Lord Jesus Christ, which was given for thee, preserve thy body and soul into everlasting life. [And here each person receiving shall say, Amen. Then shall the priest add,] Take and eat this for the remembrance of Christ who died for thee, and feed on Him in thine heart by faith, with thanksgiving.

And when he delivereth the Cup to any one he shall say,

The Blood of our Lord Jesus Christ, which was shed for thee, preserve thy body and soul into everlasting life. [And here each person receiving shall say, Amen. Then the priest shall add,] Drink this for the remembrance of Christ who shed His blood for thee, and be thankful.

If there be another Priest or a Deacon to assist the chief minister, then shall he follow with the Cup; and as the chief minister giveth the Sacrament of the Body, so shall he give the Sacrament of the Blood, in form before prescribed.

If any Bread or Wine be wanting, the Priest is to consecrate more, as is before appointed, beginning with [Our Saviour Christ in the same night] for the blessing of the Bread, and at [Likewise after Supper, &c.] for the blessing of the Cup.

In the Communion time shall be sung (where there is a Quire),

O Lamb of God that takest away the sins of the world, have mercy upon us: and, O Lamb of God that takest away the sins of the world, grant us Thy peace; together with some or all of these sentences of holy Scripture following:—Rom. xi. 33; Ps. ciii. 1—5; Luke i. 68. 74, 75; 1 Cor. i. 30, 31; John v. 13; John viii. 31, 32; Matt. xxiv. 13; Luke xii. 37, 40; John xii 35, 36; Rom. xiii. 12—14; 1 Cor. iii. 16, 17; 1 Cor. vi. 20; John xv. 8. 12; Eph. v. 1, 2; Rom. viii. 23; Apoc. v. 12, 13.

And where there is no Quire, let the Communicants make use of the same at their own private and devout meditations.

When all have communicated, he that celebrateth shall return to the Lord's Table, and reverently place upon it what remaineth of the consecrated elements, covering the same with a fair Linnen cloth, and then say,

The Lord be with you.

Answer.

And with thy spirit.

Priest.

Let us pray.

Almighty and everliving God . . . world without end. Amen.

Then shall be said or sung,

Glory be to God on high . . . the Father Amen.

[Divided by Cosin into four paragraphs.]

Then the Priest . . . blessing.

[Benediction as now.]

ing" are intended to apply to him as well as to those to whom he delivers the Communion. The usage of the Catholic Church generally, both East and West, is for the Celebrant after kneeling in adoration to receive standing, because his receiving is part of his official action as Priest. The Eastern Church, following, no doubt, herein the earliest custom (for we know from Tertullian, that even to kneel in prayer on a Sunday was thought unbecoming the Christian joyfulness and triumph of the day), does not even require her communicants generally to kneel, but to reverently bow the head. As will be seen by the note below, Bishop Cosin proposed to introduce a rubric on the subject, enjoining the Celebrant to kneel while receiving, and to use the words he uses to others.

The most ancient form in the delivery of the elements was "The Body of Christ," and "The Blood of Christ," to each of which the people answered "Amen." [Ambros. De Myst. iv. 5, Aug. Serm. 272.] In the time of Gregory the Great it was "The Body of our Lord Jesus Christ preserve thy soul," to which by the time of Aleuin and Micrologus²[xxiii.] was added "unto everlasting life." The usual form in England appears to have been "The Body of our Lord Jesus Christ preserve thy body and thy soul unto everlasting life. Amen." After the restoration of the Cup the forms provided in 1548 were, "The Body of our Lord Jesus Christ, which was given for thee, preserve thy body, &c.," and "The Blood of our Lord Jesus Christ, which was shed for thee, preserve thy soul, &c.," with which compare, "that our sinful bodies may be made clean by His body, and our souls washed through His most precious blood," in the Prayer of Humble Access. In 1549, "Preserve thy body and soul" was said in each case, as now, probably after the above ancient form.

The ancient words with which the Celebrant received, as directed in the Salisbury Missal, are given in the text. They were the same in that of Bangor. The other two great Uses of the Church of England had as follows:—

York.—"Corpus D. N. J. C. sit mihi remedium sempiternum in vitam æternam. Amen:" and, "Sanguis D. N. J. C. conservet me in vitam æternam. Amen. Corpus et Sanguis D. N. J. C. custodiat corpus meum et animam meam in vitam æternam. Amen." *Hereford.*—"Corpus D. N. J. C. sit animæ meæ remedium in vitam æternam. Amen:" and, "Sanguis D. N. J. C. conservet animam meam in vitam æternam. Amen." In the modern Roman use it is only "custodiat animam meam in vitam æternam. Amen," at the Celebrant's reception both of the Bread and of the Cup, and at the delivery of the Bread to the communicants.

The clauses now subjoined in each case, "Take and eat," &c., and "Drink this," &c., were in 1552 substituted in place of the first, which were then dropped altogether, but were restored at the restoration of the Prayer Book under Elizabeth in 1559, and prefixed, as now, to the new forms.

L'Estrange [Alliance of Divine Offices] says:—"Excellently well done was it of Q. Elizabeth's Reformers to link them both together: for between the Body and Blood of Christ in the Eucharist, and the Sacramental Commemoration of His Passion, there is so inseparable a league, as *subsist* they cannot unless they *consist*. A Sacramental verity of Christ's Body and Blood there cannot be, without the commemoration of his Death and

Underneath these alterations of Cosin's, on the page which contains the Prayer of Consecration, there is written the following note in Sancroft's hand:—

"My LL. y^e BB. at Elie house orderd all in y^e old method, thus: First y^e prayer of Address, We do not presume, &c. Aft y^e Rubrick *When y^e priest stands, &c.*, y^e prayer of Consecrōn unalterd (only one for own, and Amen at last), wth the marginal Rubrics. Then (y^e memorial or prayer of Oblation omitted, and y^e L^d prayer) follow y^e Rubrics and Forms of Participation and Distribution to y^e end of y^e Rubrick, *when all have edicated, &c.* Altogether as in this book; only y^e Rubrick, *In y^e Cōmō time shall be sung, &c.*, wth y^e sentences following, wholly omitted. And y^e y^e Lords Prayer and Collect, O L^d and Heav. F., &c. &c. to y^e end."

ceed to deliver the same to the Bishops, Priests, and Deacons, in like manner, (if any be present,) and after that to the people also in order, into their hands, all meekly kneeling. And, when he delivereth the bread to any one, he shall say,

John vi. 33. 51.
54.
1 Cor. xi. 24.

THE Body of our Lord Jesus Christ, which was given for thee, preserve thy body and soul unto everlasting life. Take and eat this in remembrance that Christ died for thee, and feed on him in thy heart by faith with thanksgiving.

¶ And the Minister that delivereth the Cup to any one shall say,

John vi. 54—56.
1 Cor. xi. 26.
Ps. cxvi. 12, 13.
1 Thess. v. 23.

THE Blood of our Lord Jesus Christ, which was shed for thee, preserve thy body and soul unto everlasting life. Drink this in remembrance that Christ's Blood was shed for thee, and be thankful.

¶ If the consecrated bread or wine be all spent before all have Communicated, the Priest is to consecrate more according to the form before prescribed: Beginning at [Our Saviour Christ in the same night, &c.] for the blessing of the bread; and at [Likewise after Supper, &c.] for the blessing of the cup.

AVE in æternum sanctissima caro Christi: mihi ante omnia et super omnia summa dulcedo. Corpus Domini nostri Jesu Christi sit mihi peccatori via et vita. In No[m]ine Patris et Filii et Spiritus Sancti. Amen. *Hic sumat corpus*

¶ Deinde ad sanguinem cum magna devotione, dicens,

AVE in æternum cœlestis potus mihi ante omnia et super omnia summa dulcedo. Corpus et Sanguis Domini nostri Jesu Christi prosint mihi peccatori ad remedium sempiternum in vitam æternam. Amen. In No[m]ine Patris, et Filii et Spiritus Sancti. Amen. *Hic sumat sanguinem*

Corpus Domini nostri Jesu Christi custodiat corpus tuum et animam tuam in vitam æternam. Amen.]

[Ritus Baptistandi. De extrema Unctione.]

Passion, because Christ never promised His mysterious (yet real) presence, but in reference to such commemoration: nor can there be a true commemoration without the Body and Blood exhibited and participated; because Christ gave not those visible elements, but His Body and Blood to make that Spiritual Representation." This view gives to the latter clause the character of an oblation in the case of each communicant.

to the Bishops, Priests, and Deacons] i. e., actually taking part in the Service, not when merely present unofficially among the congregation. Compare the Rubric of 1552, "And next deliver it to other Ministers, if any be there present, that they may help the chief Minister." So also the Scotch Liturgy of 1687, "that they may help him that celebrateth."

in order] i. e., first the men and then the women, according to the practice usual in some of the best-ordered churches.

into their hands] Communicants ought instead of taking it with their fingers to receive the consecrated Bread in the palm of the right hand, according to St. Cyril's direction in his fifth Catechetical Lecture, "Making thy left hand a throne for the right which is about to receive a king, hollow thy palm, and so receive the Body of Christ, saying thereafter the Amen."

And, when he delivereth] 1548 and 1549 have, "And when he delivereth the Sacrament of the Body of Christ he shall say to every one these words." The practice of saying the words only once for each group of communicants as they kneel before the altar is contrary to the plain direction of the Prayer Book and of Canon 21, and inconsistent with the individualizing love of Christ and of His Church for souls. The large number of communicants is no excuse for it. The remedy for that difficulty is to divide the number by more frequent celebrations. The question was raised at the last Revision, and the Bishops answered those who desired that it might "suffice to speak the

words to divers jointly," in these words: "It is most requisite that the minister deliver the Bread and Wine into every particular communicant's hand, and repeat the words in the singular number; for so much as it is the propriety of Sacraments to make particular oblation to each believer, and it is our visible profession that by the grace of God Christ tasted death for every man." [Cardwell, Conf. p. 354.]

It is a very ancient and primitive custom for the communicant to say "Amen" on receiving the consecrated elements. The Apostolical Constitutions and St. Cyril [Catech. Myst. 5. 18] attest its use in the East; Tertullian, Saints Ambrose, Augustine, Jerome, and Leo in the West. Bishops Andrewes, Cosin, Sparrow, and Wilson recommend it. The Scotch Liturgy of 1687 directs it.

During the actual delivery of the elements the Antiochene Liturgy of St. James, and the Mozarabic Liturgy, direct the 34th Psalm to be sung, a custom alluded to both by St. Jerome and by St. Cyril of Jerusalem.

The English Liturgy of 1549 directed the clerks "in the Communion time" to sing the *Agnus Dei*, "O Lamb of God," &c.

The American Liturgy orders "a Hymn, or part of a Hymn, from the Selection for the Feasts and Fasts," &c.

The form of Communion Service in the "Simplex ac pia deliberatio" of Archbishop Hermann of Cologne, directs that where there are Clerks the *Agnus Dei* should be sung both in German and in Latin, and if there be time the German hymn, "*Gott sey gelobet*," and "*Jesus Christus onser heylandt*." Among his suggestions submitted to Convocation, Bishop Cosin made one to a similar effect, as shown in a preceding note; and a relic of the custom still remains at Durham Cathedral, where a soft voluntary is played during the Communion. [See also p. lxiv.]

If the consecrated bread or wine be all spent] The Com-

¶ *When all have communicated, the Minister shall return to the Lord's Table, and reverently place upon it what remaineth of the consecrated Elements, covering the same with a fair linen cloth.*

¶ *Then shall the Priest say the Lord's Prayer, the people repeating after him every Petition.*

OUR Father, which art in heaven, Hallowed be thy Name. Thy kingdom come. Thy will be done in earth, As it is in heaven. Give us this day our daily bread. And forgive us our trespasses, As we forgive them that trespass against us. And lead us not into temptation; But deliver us from evil: For thine is the kingdom, The power, and the glory, For ever and ever. Amen.

Then the Deacon, taking the sacred paten, and holding it over the sacred chalice, . . . with care and reverence covers it with the veil. In like manner he covers the paten with the asterisk, and that with its veil.

Liturgy of St. Chrysostom.

PATER noster, qui es in cœlis; sanctificetur nomen tuum: adveniat regnum tuum: fiat voluntas tua, sicut in cœlo, et in terra. Panem nostrum quotidianum da nobis hodie: et dimitte nobis debita nostra, sicut et nos dimittimus debitoribus nostris: et ne nos inducas in tentationem: sed libera nos a malo. Amen.

munion Office of 1548 makes provision for the consecration of a second or third Chalice, "or more likewise," in case of need arising from the small size of the Chalices in use before the Reformation, when only the Celebrant partook of the Cup; but makes no such provision in case of the failure of the consecrated Bread. The Liturgies of 1549 and 1552 make no provision for either case. The present rubric was added at the last Revision.

covering the same with a fair linen cloth] The name for this fair linen cloth in the Western Church has always been the Corporal: in the Eastern Church it is called the Veil. It is mentioned in the Liturgy of St. Chrysostom, and in the Sacramentary of St. Gregory there is a prayer for its benediction. It has been already mentioned that the idea of the corporal is associated with the linen clothes in which the Body of our Lord was wrapped when laid in the Sepulchre. Its use is a witness to the doctrine of the Church respecting the effect of Consecration upon the Elements. Were the Elements sacred only so far as they were partaken of, there could be no reason for specially directing the Priest to place what remaineth *reverently* upon the Lord's Table, for no more reverence towards them would be needed than that respect which is shown for every thing used at the Holy Communion. Still less would there be reason for so strikingly symbolical a custom as that of covering the Elements that remain with a white linen cloth: a custom which had always been ritually associated with the reverence paid to our Lord's natural Body; and with nothing else. In retaining such a custom as this, and defining it by a rubric at a time [A.D. 1661] when all rubrics were cut down to such an absolute *minimum* as must be insisted on, we have a clear proof that they who did so, believed a special sanctity to belong to the elements by virtue of their consecration, and also believed that this sanctity belonged to those elements whether or not they were received by the communicants. Evidence to the same effect is afforded by the sixth rubric at the end of the office.

The tone of thought on this subject in the Primitive Church is also indicated by a rubric in the Liturgy of St. Chrysostom: "*Then the Deacon . . . gathers together the Holy Things with fear and all safety; so that not the very smallest particle should fall out, or be left.*" St. Cyril also writes, "Give heed lest thou lose any of it." . . . If any one gave thee gold-dust, wouldst thou, not with all precaution keep it fast, being on thy guard against losing any of it, and suffering loss? How much more cautiously then wilt thou observe that not a crumb falls from thee, of what is more precious than gold and precious stones." [Catech. Lect. xxiii. 21.]

THE PRAYERS OF OBLATION AND THANKSGIVING.

§ *The Lord's Prayer.*

The repetition of the Lord's Prayer as the key-note of oblation and thanksgiving is a custom handed down to us from the Primitive Liturgies. After the Consecration, and before the Communion, says St. Cyril, "we say that Prayer which the Saviour delivered to His own disciples, with a pure conscience styling God our Father!" [Catech. Lect. xxiii. 11.] It is accordingly found here in every ancient Liturgy, except that of St. Clement. In the Gallican Liturgy (as now in the Mozarabic form of it) the Lord's Prayer was here preceded by a Proper Preface, in the same manner as the Tersanctus; and in all it was followed by the Embolismus, a prayer which was an expansion of the petition, "Deliver us from evil."

The words of St. Cyril plainly show that the Lord's Prayer was repeated, in this place, by the people as well as by the Celebrant. St. Gregory of Tours also refers to the same practice, in describing the miracle of a dumb woman who received speech at this moment to say the Lord's Prayer with the rest. St. Gregory the Great [Ep. lxiv.] says, "Among the Greeks it is the custom for the Lord's Prayer to be said by all the people, but among us by the Priest only;" and his words are found in the "Mirror of our Lady" [fol. clxxxix], showing that the custom of his day was also that of the Mediæval Church of England. It is, however, certain that the Gallican Liturgy required it to be said by all the people as well as by the Priest; and as the customs of the ancient English Church were analogous to those of that Liturgy, we may conclude that our present habit is a return to the usage of the Primitive Church in England as well as in the East.

In the Sarum Missal the Lord's Prayer was included in the Office to be said by the Clergy in the vestry after the Service at the Altar was ended. It is probable, therefore, that this custom influenced its present position—after Communion as well as after Consecration,—the public and the private recitation of it being thus combined.

§ *The Prayer of Oblation.*

It has been already remarked, in the Introduction to this Office, that if there is any room for doubt as to the completeness of the Oblation as made by the acts and words of Consecration, that doubt may be entirely dispelled by the consideration that this definite Prayer of Oblation is used while "*what remaineth of the*

1 St. Cyril goes on to give the Exposition of the Lord's Prayer, which will be found at p. 31.

¶ *After shall be said as followeth.*

Ps. l. 14. 23.
cxvi. 17.
1 Pet. ii. 5.
Heb. xlii. 15.
Eph. vi. 18.
Heb. ix. 22.
Eph. i. 7.
v. 25—27.
1 Cor. i. 30.
Rom. viii. 32.
Prov. xxiii. 26.
Rom. xii. 1.
1 Cor. vi. 20.
Ps. lxxv. 4.
1 Cor. x. 16.
Eph. i. 3.
Luke xv. 18, 19.
Isa. vi. 5.
2 Cor. viii. 12.
Ps. xix. 14.
cvii. 22.
Luke xvii. 10.
2 Chron. xxx. 18, 19.
Rom. v. 8, 9.
Eph. ii. 18.
Rom. xvi. 17.

O LORD and heavenly Father, we thy humble servants entirely desire thy fatherly goodness mercifully to accept this our sacrifice of praise and thanksgiving; most humbly beseeching thee to grant, that by the merits and death of thy Son Jesus Christ, and through faith in his blood, we and all thy whole Church may obtain remission of our sins, and all other benefits of his passion. And here we offer and present unto thee, O Lord, ourselves, our souls and bodies, to be a reasonable, holy, and lively sacrifice unto thee; humbly beseeching thee, that all we, who are partakers of this holy Communion, may be fulfilled with thy grace and heavenly benediction. And although we be unworthy, through our manifold sins, to offer unto thee any sacrifice, yet we beseech thee to accept this our bounden duty and service; not weighing our merits, but pardoning our offences, through Jesus Christ our Lord; by whom, and with whom, in the unity of the Holy Ghost, all honour and glory be unto thee, O Father Almighty, world without end. *Amen.*

Supplices te rogamus . . . ut quot-
quot ex hac Altaris participatione sacro-
sanctum Filii tui corpus et sanguinem
sumpserimus, omni benedictione cœlesti
et gratia repleamur. . . .

Salisbury Use.
Canon.

. . . non æstimator meriti, sed veniæ,
quæsumus, largitor admitte. Per Chris-
tum Dominum nostrum. . . . Per
ipsum et cum ipso et in ipso est tibi
Deo Patri Omnipotenti in unitate
Spiritus Sancti omnis honor et gloria.
Per omnia sæcula sæculorum. *Amen.*

consecrated Elements” is standing upon the Lord’s Table. While that which has just been called many times the Body and Blood of our Lord Jesus Christ, and as such “reverently” placed on the Lord’s Table, and covered “with a fair linen cloth,” still remains there, the Celebrant solemnly beseeches our Lord and Heavenly Father to accept “this our sacrifice of praise and thanksgiving,” that is, our Eucharistic Sacrifice; and he further says, that though we are unworthy to offer any sacrifice whatever, yet this one it is our bounden duty to offer to God, Whom we pray to pardon our unworthiness, and accept us and our work through Christ.

Yet there is reason to regret that this Oblation is not made—as it was in the Liturgy of 1549, and as it is now in the Scottish and the American Liturgies [see Appendix]—before instead of after the administration. Bishop Cosin has this remarkable note on the subject: “Certainly it” (the above arrangement) “was the better and more natural order of the two; neither do I know whether it were the printer’s negligence or no thus to displace it. . . . I have always observed my lord and master, Dr. Overall, to use this Oblation in its right place, when he had consecrated the Sacrament, to make an offering of it (as being the true public Sacrifice of the Church) unto God; that ‘by the merits of Christ’s death,’ which was now commemorated, ‘all the Church’ of God might receive mercy, &c., as in this prayer; and that when that was done he did communicate the people, and so end with the thanksgiving following hereafter. If men would consider the nature of this Sacrament, how it is the Christian’s Sacrifice also, they could not choose but use it so too.” For as it stands here, it is out of its place. We ought first to send up Christ unto God, and then He will send Him down to us.” [Works, v. 114.]

Dr. Overall, it should be remembered, was Bishop of Norwich, and was the author of the latter portion of the Catechism relating to the Sacraments. Thorndike also [*Just Weights*, ch. 22] says, “That Memorial or Prayer of Oblation is certainly more proper there (immediately after the Prayer of Consecration) than after the Communion.” The suggestions submitted to the Revisers of 1661 included the proposal of a “Memorial or Prayer of Oblation,” much resembling that of 1549, to follow immediately the words of Consecration. Its displacement was, we cannot doubt (if not, as Cosin suggests, accidental), one of those alterations which Bishop Horsley, in his well-known letter to the Rev. J. Skinner, on the subject of the Scotch Liturgy, condemns as made “to humour the Calvinists,” and, “in his opinion, much for the worse.”

That . . . we and all thy whole Church] The double supplication is here to be noticed. The prayer is that (1) “we,” and (2) “all Thy whole Church,” and it is also that “we may obtain remission of our sins,” and that “all Thy whole Church” may receive “all other benefits of His passion.” The latter phrase looks towards the ancient theory of the Church that the blessed Sacrament was of use to the departed as well as to the living. It is a general term used by men who were fearful of losing all such commemoration, if inserted broadly and openly, but yet feared lest no gate should be left open by which the intention of such commemoration could enter. One is reminded of the ancient Litany supplication, “By Thine unknown sufferings.”

This view is confirmed by the words of Andrewes and Cosin: “Where,” says the latter, “by all the whole Church is to be understood, as well those that have been heretofore, and those that shall be hereafter, as those that are now the present members of it. . . . The virtue of this Sacrifice (which is here in this prayer

¶ *Or this.*

Eph. v. 20.
2 Cor. ix. 15.
Matt. v. 6.
Ps. xxiii. 1-6.
John vi. 51. 53-57.
1 Pet. ii. 7.
John x. 11.
xv. 13, 14.
Rom. viii. 32.
1 Cor. x. 16, 17.
Rom. xii. 4, 5.
Eph. v. 30, 32.
iv. 15, 16.
1 Pet. i. 3, 4.
Col. i. 12-14.
John xv. 9, 11.
Eph. vi. 24.
2 Cor. xii. 9.
Acts ii. 42.
1 John i. 3, 7.
ii. 24.
iii. 6.
Eph. ii. 10.
iii. 20, 21.

ALMIGHTY and everliving God, we most heartily thank thee, for that thou dost vouchsafe to feed us, who have duly received these holy mysteries, with the spiritual food of the most precious Body and Blood of thy Son our Saviour Jesus Christ; and dost assure us thereby of thy favour and goodness towards us; and that we are very members incorporate in the mystical body of thy Son, which is the blessed company of all faithful people; and are also heirs through hope of thy everlasting kingdom, by the merits of the most precious death and passion of thy dear Son. And we most humbly beseech thee, O heavenly Father, so to assist us with thy grace, that we may continue in that holy fellowship, and do all such good works as thou hast prepared for us to walk in, through Jesus Christ our Lord, to whom, with thee and the Holy Ghost, be all honour and glory world without end. *Amen.*

¶ *Then shall be said or sung,*

Luke ii. 14.
Matt. xxi. 9.
1 Chron. xxix. 13.
Neh. ix. 5.
Ps. lxxxvi. 9.
civ. 31.
Rev. xi. 17

GLORY be to God on high, and in earth peace, good will towards men. We praise thee, we bless thee, we worship thee, we glorify thee, we give thanks to thee for thy great glory,

ALMIGHTY and everlasting God, we give thanks to thy exceeding goodness, because thou hast fed us with the body of thy only-begotten Son, and given to us this Blood to drink. We humbly beseech thee, work in us with thy spirit, that as we have received this divine Sacrament with our mouths, so we may also receive and ever hold fast with true faith thy grace, remission of sins, and communion with Christ thy Son. All which things, thou hast exhibited unto us in these sacraments, through our Lord Jesus Christ thy Son, which liveth and reigneth with thee, in unity of the Holy Ghost, very God, and very man for ever. *Amen.*]

[Daye's transl. of Hermann's Consult., A.D. 1547.]

ΔΟΞΑ ἐν ὑψίστοις Θεῷ, καὶ ἐπὶ γῆς εἰρήνη, ἐν ἀνθρώποις εὐδοκία. Αἰνοῦμέν σε, εὐλογοῦμέν σε, προσκυνοῦμέν σε, δοξολογοῦμέν σε, εὐχαριστοῦμέν σοι, διὰ τὴν μεγάλην σου δόξαν, Κύριε

“γῆρας ἐσθινός”
Codex Alexandrin. Mus. Brit.
εὐδοκία in MS.

of Oblation commemorated and represented) doth not only extend itself to the living, and those that are present, but likewise to them that are absent, and them that be already departed, or shall in time to come live and die in the faith of Christ.” [Works, v. 351. 517.]

So too Bishop Andrewes, to whom Cosin [ibid.] refers, in his answer to Cardinal Perron:—

“The Eucharist ever was, and by us is considered, both as a Sacrament and as a Sacrifice. A sacrifice is proper and applicable only to divine worship. The sacrifice of CHRIST’S death did succeed to the sacrifices of the Old Testament. The sacrifice of CHRIST’S death is available for present, absent, living, dead (yea, for them that are yet unborn). When we say the dead, we mean it is available for the apostles, martyrs, and confessors, and all (because we are all members of one body): these no man will deny.

“In a word, we hold with St. Augustine, in the very same chapter which the Cardinal citeth: ‘Quod hujus sacrificii caro et sanguis, ante adventum CHRISTI, per victimas similitudinum promittebatur; in passione CHRISTI, per ipsam veritatem reddebatur; post adventum [? ascensum] CHRISTI, per Sacramentum memoriae celebratur.’” [Minor Works, Ang. Cath. Lib. p. 19.]

§ *The Thanksgiving.*

A prayer of thanksgiving formed a conspicuous feature in all the Primitive Liturgies, but it had dropped out of the mediæval service, except in the form of a private prayer of the Cele-

brant. That which was introduced into our Liturgy was partly taken from Hermann’s Consultation: but there is much resemblance between it and the corresponding part of the Liturgy of St. James, which is as follows:—“We give Thee thanks, Christ our God, that Thou hast vouchsafed to make us partakers of Thy Body and Blood, for the remission of sins, and eternal life. Keep us, we beseech Thee, without condemnation, because Thou art good, and the lover of men. We thank Thee, God and Saviour of all, for all the good things which Thou hast bestowed on us; and for the participation of Thy holy and spotless mysteries. . . . Glory to Thee, Glory to Thee, Glory to Thee, Christ the King, Only-begotten Word of the Father, for that Thou hast vouchsafed us sinners and Thy unworthy servants to enjoy Thy spotless mysteries, for the forgiveness of sins, and for eternal life: Glory to Thee.”

It should be remembered that the words “who have duly” apply to all who have received, “duly” being the English word for “rite,” i. e., according to proper form and ordinance.

§ *The Gloria in Excelsis.*

The use of a Hymn of Thanksgiving after the Communion may be reasonably associated with what is recorded of our Lord and

“... quod incipiatur semper in medio altaris quandocunque dicitur.” [Sar.] “In medio altaris erectis manibus incipiat Gloria in Excelsis Deo.” [Ebor.] “Quo dicto eat sacerdos ad medium altaris: et elevando manus suas dicit, Gloria in Excelsis Deo.” [Herford.]

John xiii. 13.
xx. 28.
John i. 14.
Rev. v. 12—14.
John i. 29.
Heb. i. 3.
John xiv. 14.
1 John v. 14.
Mark xvi. 19.
Acts vii. 55, 59.
1 Tim. vi. 15.
Rev. xv. 3, 4.
Rom. ix. 5.
John xvii. 5.
Eph. ii. 18.

O Lord God, heavenly King, God the Father Almighty.

O Lord, the only-begotten Son Jesu Christ; O Lord God, Lamb of God, Son of the Father, that takest away the sins of the world, have mercy upon us. Thou that takest away the sins of the world, have mercy upon us. Thou that takest away the sins of the world, receive our prayer. Thou that sittest at the right hand of God the Father, have mercy upon us.

Rev. xv. 4. For thou only art holy, thou only art the Lord, thou only, O Christ, with the Holy Ghost, art most high in the glory of God the Father.
Amen.

βασιλεῦ, ἐπουράνιε, Θεὲ Πατὴρ παντοκράτωρ.

Κύριε Υἱὲ μονογενῆ, Ἰησοῦ Χριστέ, καὶ Ἅγιον Πνεῦμα, Κύριε ὁ Θεὸς, ὁ Ἄμωός τοῦ Θεοῦ, ὁ Υἱὸς τοῦ Πατρὸς, ὁ αἴρων τὰς ἁμαρτίας τοῦ κόσμου, ἐλέησον ἡμᾶς, ὁ αἴρων τὰς ἁμαρτίας τοῦ κόσμου [ἐλέησον ἡμᾶς,] προσδέξαι τὴν δέησιν ἡμῶν, ὁ καθήμενος ἐν δεξιᾷ τοῦ Πατρὸς, ἐλέησον ἡμᾶς. [An addition from later hand.]

Ὅτι σὺ εἶ μόνος ἅγιος, σὺ εἶ μόνος Κύριος, Ἰησοῦς Χριστὸς, εἰς δόξαν Θεοῦ Πατρὸς. Ἀμήν.

His Apostles at the first Institution of the Holy Eucharist; that, "when they had sung an hymn," they left the upper chamber as having thus concluded the sacred service. [Matt. xxvi. 30.] The hymn or psalm then sung was probably part of the great Hallel, i. e., of Psalms 113—118, of which an account will be found in the Notes on those psalms. Or it might be, as Archdeacon Freeman considers [Princip. Div. Serv. II. ii. 377], the "Praise-song" still in use among the Jews, and in which he traces some remarkable coincidences of expression with our Lord's great Eucharistic Prayer. In the Armenian Liturgy the 34th Psalm, and in the Constantinopolitan the 23rd Psalm, are sung after the Communion.

The ordinary position of the Gloria in Excelsis in ancient Liturgies was, however, at the beginning, not at the end of the Office. It occupied such a position in our own Liturgy until 1552, when among the other changes made was that of turning the Gloria in Excelsis into a Post-Communion Thanksgiving. At the same time was added a third "Thou that takest away the sins of the world," having in view probably the threefold Agnus Dei which was until then used as a Post-Communion. The only other Liturgy in which it has such a position is, according to Palmer [Origin. Liturg. iv. § 23], that in use among the Irish monks of Luxovium in Gaul in the seventh century. Bold as was the change thus made by the Revisers of 1552, there is so striking an appropriateness in the present position of the Gloria in Excelsis that there is reason to rejoice at the alteration rather than to regret it: and it may be truly said that there is no Liturgy in the world which has so solemn and yet so magnificent a conclusion as our own.

The Gloria in Excelsis,—or, as it is called in the Oriental Church, "The Angelical Hymn," or "Great Doxology,"—is of great antiquity, having been used from very early times as a daily morning hymn [προσευχὴ ἑωθινή] in combination with what is evidently the germ of the Te Deum. [See p. 11.] This use of it is mentioned in the Apostolical Constitutions [vii. 47], where a text somewhat differing from the above is given [Daniel's Thesaur. Hymnolog. ii. 269]: and it is also quoted and directed to be used by St. Athanasius in his treatise on Virginité. [De Virgin. tom. ii. p. 122, Bened.] St. Chrysostom frequently mentions it, especially as used by ascetics for a morning hymn: and the title of it in Athelstan's Psalter is "Hymnus in die Dominica ad Matutinas."

Its introduction into the Liturgy appears to have been gradual. It does not appear to have been thus used in the East, except among the Nestorians, at any time; but the first words of it are found in the Liturgy of St. James, and another portion of it in that of St. Chrysostom: "Thee we hymn, Thee we praise; to

Thee we give thanks, Lord, and pray to Thee, our God." The germ of it was evidently used in Apostolic times, and perhaps the holy martyr Polycarp was quoting it, when among his last words he said, Διὰ τοῦτο καὶ περὶ παντῶν σὲ αἰνῶ, σὲ ἐβλόγα, σὲ δοξάζω. [Euseb. Ecc. Hist. iv. 15.]

Ancient liturgical writers state that the Gloria in Excelsis as now used was composed by Telesphorus, Bishop of Rome, A.D. 128—138, but it does not appear that he did any thing more than order the first words, the actual Angelical Hymn, to be sung in the Mass. Alcuin attributes the latter part of it to St. Hilary of Poitiers [A.D. 350—367], whose name has also been associated with the Te Deum: but it is clear that it was in use in its complete form when Athanasius wrote his treatise on virginity, and that it was then too familiar to the Church for a recent composition. The truth may possibly be that St. Hilary separated the ancient Morning Hymn of the Church into two portions, the first of which we know as the Gloria in Excelsis, and the second as the Te Deum. Symmachus, Bishop of Rome, A.D. 500, definitely appropriated the Angelical Hymn to its present use as an Eucharistic thanksgiving, placing it in the position before spoken of, at the beginning of the Communion Office.

It appears to have been an ancient custom to expand the Gloria in Excelsis somewhat in the same manner as the Kyrie Eleison [see p. 167]. The following is such an expanded form, arranged for the Festival of our Lord's Nativity:—

"Gloria in excelsis Deo, et in terra pax hominibus bonæ voluntatis. Laudamus Te, *Laus Tua, Deus, resonet coram Te rex.* Benedicimus Te, *Qui venisti propter nos Rex angelorum Deus.* Adoramus Te, *Gloriosum regem Israel in throno Patris Tui.* Glorificamus Te, *veneranda Trinitas.* Gratias agimus Tibi, *propter magnam gloriam Tuam, Domine Deus Rex celestis, Deus Pater Omnipotens. Domine Fili unigenite Jesu Christe, Domine Deus, Agnus Dei, Filius Patris, qui tollis peccata mundi, miserere nobis. Qui tollis peccata mundi suscipe deprecationem nostram. Qui sedes ad dexteram Patris miserere nobis, In sede majestatis Tue.* Quoniam Tu solus sanctus, *Deus fortis et immortalis: Tu solus Dominus, Cælestium, terrestrium, et infernorum Rex: Tu solus altissimus, Rex regum regnum Tuum solidum permanebit in æternum, Jesu Christe. Cum sancto Spiritu in gloria Dei Patris. Amen.*"

This is given by Pamelius [Liturgicon ii. 611], and he also prints another which was used at the Dedication of a Church. Although there is much beauty in such an arrangement, the reverent remark of Cardinal Bona is very applicable. He says, after quoting these two forms, "Non desunt alia exempla, sed ista superflua sunt, ut quisque agnoscat temerario quorundam ausu, seu potius simplicitate, ac zelo qui non erat secundum

¶ *Then the Priest (or Bishop if he be present) shall let them depart with this blessing.*

[*Deinde si episcopus celebraverit, diaconus ad populum conversus baculum episcopi in dextera tenens, curvatura baculi ad se conversa dicat hoc modo. Humiliate vos ad benedictionem.* Salisbury Use.

Deut. xxi. 5.
Heb. vii. 7.
Phil. iv. 6, 7.
2 Thess. iii. 5.
Numb. vi. 23—26.
Ps. cxxxiv. 3.
Eph. i. 3.
2 Cor. xiii. 14.

THE peace of God, which passeth all understanding, keep your hearts and minds in the knowledge and love of God, and of his Son Jesus Christ our Lord: And the blessing of God Almighty, the Father, the Son, and the Holy Ghost, be amongst you, and remain with you always. *Amen.*

PAX Domini ✠ sit semper vobiscum.]

Benedictio Dei Patris et Filii et Spiritus Sancti, et pax Domini, sit semper vobiscum. Leofric's Exeter Pontifical. at maneat.

¶ *Collects to be said after the Offertory, when there is no Communion, every such day one or more; and the same may be said also, as often as occasion shall serve, after the Collects either of Morning or Evening Prayer, Communion, or Litany, by the discretion of the Minister.*

Zech. xii. 10.
Rom. viii. 26.
Ps. xxxii. 8.
1 Thess. v. 9.
1 Pet. i. 9.
1 John ii. 17.
James iv. 14.
Ps. cxlvi. 5, 6.
Heb. xlii. 6.

ASSIST us mercifully, O Lord, in these our supplications and prayers, and dispose the way of thy servants towards the attainment of everlasting salvation; that, among all the changes and chances of this mortal life, they may ever be defended by thy most gracious and ready help; through Jesus Christ our Lord. *Amen.*

ADESTO, Domine, supplicationibus nostris: et viam famulorum tuorum in salutis tuæ prosperitate dispone: ut inter omnes viæ et vitæ hujus varietates, tuo semper protegantur auxilio. Per Dominum.

Salisbury Use.
Missæ pro iter agentibus.
Greg. *ibid.*
Gelas., *ad Prim.*

scientiam, inserta hæc Angelico hymno fuisse, quæ Ecclesiasticam gravitatem minime redolent, cultumque divinum non augent, sed diminuunt.¹ [Rer. Liturg. II. iv. 6.]

THE BLESSING.

This beautiful Benediction is peculiar to the English Liturgy, both as to form and place. It is plainly intended to be a substitute for the Benediction anciently given after the Lord's Prayer and the Fraction of the Bread, and before the Agnus Dei. The latter half of it is analogous to a Benediction used in Anglo-Saxon times and given in the Appendix to Hickeys' Letters, as well as in the Exeter Pontifical [see also Confirmation Office]: the former half is a reversion from the old Liturgical form to one containing more of the actual words of Holy Scripture: "And the peace of God, which passeth all understanding, shall keep

your hearts and minds through Christ Jesus." [Phil. iv. 7.] This former part alone was used in "The Order of Communion" of 1548.

A comparison of the modern and ancient rubrics (for the latter of which see the Burntisland edition of the Sarum Missal, 622 f.) will show that this Blessing is to be considered a special sacerdotal act, belonging of right to the episcopal office, and devolving from it to the Priest, in the absence of the Bishop. As Absolution conveys actual pardon of sins to the true penitent, so does Benediction convey a real benefit to the soul when received in faith at the mouth of God's minister.

This Benediction is commonly used on other occasions in the full form in which it is here given; but it seems better to use it thus only in connexion with the Holy Communion, and at other times to begin with "The Blessing of God Almighty," as at the end of the Confirmation Service, and as was the ancient custom. Bishop Cosin inserted it thus at the end of the Burial Office, but the Commissioners substituted 2 Cor. xiii. 14.

THE OCCASIONAL COLLECTS.

The rubric which precedes these Collects originally extended only as far as "Every such day one;" all that follows was added in 1552. Bishop Cosin amended it thus:—"Collects to be said one or more at the discretion of the Minister, before the final Collect of Morning and Evening Prayer, Litany, or Communion, as occasion shall serve: as also after the Offertory, or Prayer for the estate of Christ's Church, when there is no Communion celebrated." But although this emendation was not erased, the rubric was printed in the old form. By "before the final Collect," Cosin meant before what is headed the "third" Collect in Morning and Evening Prayer. He erased the words

¹ The following interpolated version is taken from "The Mirror of our Lady," and shows to what length such free handling of ancient forms has been carried by indiscreet persons:—"Glory be to god, on hy. And peace in erthe to men of good wylle. we prayse the. we blysse the. we worship the. we glorify the. we thanke the. for thy grete glory Lorde god heuenly kynge. god father almyghty. Lorde onely sone of mary Jesu cryste. Lorde god. lambe of god. sone of the father that doest away the synnes of the worlde haue mercy on vs. by the moste pytful prayer of thy mother mary vyrgyn. Thou that doest away the synnes of the worlde. receyue oure prayer. that we mote cotynually please the and thy holy mother mary vyrgyn. Thou that syttest on the righte syde of the father. haue mercy on vs. by ye suffrages of mary. that is mother and daughter of her sone. For thou only art holy. mary only is mother and vyrgyn. Thou only arte lorde. Mary onely ys a lady. Thou only arte hyest. father and sone of mary. Jesu criste to the holy goste in glory of god the father. Amen." Such forms are said by Daniel [Thesaur, Hymnol. ii. 273] to be in almost all German Missals of the middle ages; and there was one of a similar kind ordered by the later Sarum Missals to be sung daily at the Mass in Lady Chapels.

Hab. i. 12.
Jer. x. 23.
Ps. xxviii. 9.
cxix. 35-37.
1 Thess. v. 23.
2 Thess. iii. 5.
Ps. lxxxix. 13.
18. xvii. 8.
lxxxvi. 2.
John x. 28, 29.
Rom. viii. 35, 36,
39.

O ALMIGHTY Lord, and everlasting God, vouchsafe, we beseech thee, to direct, sanctify, and govern, both our hearts and bodies in the ways of thy laws, and in the works of thy commandments; that through thy most mighty protection, both here and ever, we may be preserved in body and soul, through our Lord and Saviour Jesus Christ. *Amen.*

Ps. xc. 7, 8.
Luke viii. 15, 16.
2 Tim. iii. 16.
James i. 21, 22.
John xv. 2.
Col. i. 5, 6, 9, 10.
Phil. i. 11.
1 Cor. iii. 6.

GRANT, we beseech thee, Almighty God, that the words which we have heard this day with our outward ears, may through thy grace be so grafted inwardly in our hearts, that they may bring forth in us the fruit of good living, to the honour and praise of thy Name; through Jesus Christ our Lord. *Amen.*

Ps. lxxxix. 8.
Jer. x. 23.
Ps. xxxvii. 5, 23.
1 Cor. x. 31.
Phil. i. 6.
Heb. iii. 14.
1 Pet. iv. 11.
Rom. vi. 22, 23.
xi. 36.

PREVENT us, O Lord, in all our doings with thy most gracious favour, and further us with thy continual help; that in all our works begun, continued, and ended in thee, we may glorify thy holy Name, and finally by thy mercy obtain everlasting life, through Jesus Christ our Lord. *Amen.*

Ps. xxxvi. 9.
Prov. ii. 6.
James i. 5.
Matt. vi. 8, 31, 32.
Rom. viii. 26.
Ps. cxli. 13, 14.
Luke vii. 6, 7.
xviii. 13, 14.
Rev. iii. 17, 18.
Heb. iv. 14, 16.

ALMIGHTY God, the fountain of all wisdom, who knowest our necessities before we ask, and our ignorance in asking; We beseech thee to have compassion upon our infirmities; and those things, which for our unworthiness we dare not, and for our blindness we cannot ask, vouchsafe to give us for the worthiness of thy Son Jesus Christ our Lord. *Amen.*

John xvi. 23, 24,
26, 27.
Heb. x. 19.
1 Kings viii. 59.
Ps. xxxiv. 15, 17.
cxvi. 1, 2.

ALMIGHTY God, who hast promised to hear the petitions of them that ask in thy Son's Name; We beseech thee mercifully to incline

DIRIGERE et sanctificare et regere dignare, Domine Deus, quæsumus, corda et corpora nostra in lege tua, et in operibus mandatorum tuorum: ut hic et in æternum, te auxiliante, sani et salvi esse mereamur. Per.

Salisbury Use.
ad Prim.
Greg. *ibid.*

FINALLEMENT, nous te prions que la parole laquelle nous avons ouye presentement, prenne racine en noz cœurs, tellement qu'elle rende ses fruictz en temps convenable. Et nous donne les choses expedientes et necessaires, tant a la vie spirituelle que corporelle. Ainsi que nous le demandons en l'oraison, que ton Filz Jesus Christ nous à apprise, Nostre Pere . . .]

[Poullain's
L'Ordre, &c.,
1552 ed.]

ACTIONES nostras, quæsumus, Domine, et aspirando præveni et adjuvando proseguere: ut cuncta nostra operatio et a te semper incipiat, et per te cœpta finiatur. Per.

Salisbury Use.
Canon Missæ ad
An. Greg.
Sabb. in xii. lect.
mensis primi.

"second" and "third" before "Collect" in both headings, and introduced between them, at Evening Prayer, the ancient Prime Collect, "O Almighty Lord and everlasting God," under the title of "The Collect for grace and protection." From this correction, and from its being set aside, it is evident that these Occasional Collects, which Cosin wished to use *before* the third Collect, are intended to be used after it, and not after the Prayer of St. Chrysostom, which is nowhere called a "Collect" in the Book of Common Prayer. It seems as if the conclusion of the Service with the third Collect [see p. 25] was considered by

some to be too abrupt; and that, therefore, discretion was given to use one of these Collects in addition.

The first, second, and fourth of these Occasional Collects are translated from ancient forms, used for many ages in the Church of England. The third is found in the Book of Prayers printed by Pollanus; but whether he took it from the English Prayer Book, or whether both came from some common ancient original, cannot be determined. The fifth and sixth appear to be compositions of the Reformers, the latter reading like a paraphrase of the Prayer of St. Chrysostom.

Matt. xxi. 22.
 J. John iii. 21, 22.
 v. 14, 15.
 Phil. iv. 19.
 Ps. l. 15,
 cxv. 17, 18.
 Eph. i. 3.

thine ears to us that have made now our prayers and supplications unto thee; and grant, that those things which we have faithfully asked according to thy will, may effectually be obtained, to the relief of our necessity, and to the setting forth of thy glory; through Jesus Christ our Lord. *Amen.*

¶ *Upon the Sundays and other Holy-days (if there be no Communion) shall be said all that is appointed at the Communion, until the end of the general Prayer [For the whole state of Christ's Church militant here in earth] together with one or more of these Collects last before rehearsed, concluding with the Blessing.*

¶ *And there shall be no celebration of the Lord's Supper, except there be a convenient number to communicate with the Priest, according to his discretion.*

¶ *And if there be not above twenty persons in the Parish of discretion to receive the Communion; yet there shall be no Communion, except four (or three at the least) communicate with the Priest.*

THE FINAL RUBRICS.

These "Cautelæ Missæ" were inserted in 1552, superseding some longer rubrics which had been placed here in the Prayer Book of 1549: but some important alterations were made by Cosin, some of which were adopted by the Commissioners in 1661.

Upon the Sundays and other Holy-days] The Liturgy of 1549 here ordered that when there were "none to communicate with the Priest" he should still "say all things at the altar, appointed to be said at the celebration of the Lord's Supper, until after the Offertory," concluding with "one or two of the Collects aforewritten," and the "accustomed blessing." The present paragraph was substituted in 1552, but without the words "Sundays and other" before "holy-days," and without the direction to conclude with the Blessing. These were added in 1661. The Scottish Liturgy of 1637 does not order the Blessing to be given.

It is observable that our Communion Office contains absolutely no hint as to whether or when, on occasion of a celebration, persons present in the Church and not intending then to communicate are to withdraw. Still less is there any warrant for the practice of dismissing the non-communicants with one or two of the preceding Collects and "The grace of our Lord." The Church clearly intends, however, that the Alms should always be collected from the whole of the congregation, and that all should stay to the end of the Prayer for the Church Militant. Then, "if there be no Communion," the Priest is to dismiss the whole congregation with one or more of the Collects and the Blessing. The Service would then be what Durandus [Div. Off. iv. l. 23] calls a "Missa Sicca," i. e., when "the Priest, being unable to celebrate, because he has already done so, or for some other reason, puts on his stole, reads the Epistle and Gospel, and says the Lord's Prayer, and gives the Benediction." The same sort of service is said by Socrates [Hist. Eccl. bk. v. ch. 22] to have been in use in the Church of Alexandria.

If, on the other hand, there is a celebration, non-communicants are permitted, not commanded, to withdraw; whilst communicants, drawing nearer towards the chancel and the altar (tarrying "still in the quire, or in some convenient place nigh the quire, the men on the one side, and the women on the other side," 1549), so as to be "conveniently placed for the receiving of the Holy Sacrament," are more specially addressed in the Exhortation, "Dearly beloved in the Lord, ye that mind to come," &c. With regard to the question of non-communicating attendance, it is best left open, as the wisdom of the Church has left it. The presence of persons, who, being regular communicants at certain intervals, may not feel prepared to receive at every celebration, but yet may scruple to leave the Church, and may wish devoutly

to use the opportunity for prayer and intercession, cannot fairly be called non-communicant attendance, and could not be forbidden without needless cruelty. The probably rare occurrence of the presence of persons who have never communicated, and are not preparing to do so, ought to be discouraged. But it would in most cases be wise to encourage young persons preparing for their first Communion to remain throughout the whole Service. The fact of never having witnessed the actual Celebration and Communion, joined to the natural shyness of the English character, has probably in numerous cases delayed the first Communion for years.

the whole state of Christ's Church militant here in earth] This phrase was altered by Cosin into "the good estate of Christ's Catholick Church," which is found in the Occasional Prayer for all Conditions of Men [see p. 65], and was printed here in many Prayer Books after that of 1662 was enacted, as if there was some authority for the expression. [See also p. 175.]

a convenient number] This is defined, by the next rubric, to be "four (or three at the least)" besides the Priest himself. The rule is in agreement with the directions given by several ancient Councils. The forty-third Canon of the Council of Mentz [A.D. 813] forbade priests to say Mass when there was no one else present. That of Paris [A.D. 829] says in its forty-eighth Canon, that "a blameworthy custom has in very many places crept in, partly from negligence, partly from avarice, viz. that some of the priests celebrate the solemn rites of masses without ministers." A Council at York [A.D. 1195] decrees that no priest shall celebrate, "sine ministro literato;" and many others of a similar kind might be quoted.

Yet there is no essential reason why this rule should be enforced. Should a celebration and communion take place in the chamber of a sick person, "in time of plague . . . when none of the parish or neighbours can be gotten to communicate with the sick in their houses for fear of the infection," and only the priest and the one sick person are there, it is quite as valid as if "four, or three at the least" were present. The reason, moreover, assigned by Councils and by Liturgical writers against Solitary Masses is that there is an indecorum and absurdity in saying "The Lord be with you," and similar versicles, when there is no one present: a difficulty which has been supposed to be met by the suggestion that the priest addresses himself to the absent Church "as present by faith and communicating in the Sacraments by charity."

On the whole it must be considered that the rule is one of expediency, and not of principle. It arose out of two conflicting causes, (1) The anxiety of the Clergy to offer up the Holy Eucharist day by day for the benefit of the Church, and (2) the indifference of the laity to frequent Communion. Bishop Cosin wrote, "Better were it to endure the absence of people, than for

- ¶ *And in Cathedral and Collegiate Churches, and Colleges, where there are many Priests and Deacons, they shall all receive the Communion with the Priest every Sunday at the least, except they have a reasonable cause to the contrary.*
- ¶ *And to take away all occasion of dissension, and superstition, which any person hath or might have concerning the Bread and Wine, it shall suffice that the Bread be such as is usual to be eaten; but the best and purest Wheat Bread that conveniently may be gotten.*
- ¶ *And if any of the Bread and Wine remain unconsecrated, the Curate shall have it to his own use: but if any remain of that which was consecrated, it shall not be carried out of the Church, but the Priest and such other of the Communicants as he shall then call unto him, shall, immediately after the Blessing, reverently eat and drink the same.*
- ¶ *The Bread and Wine for the Communion shall be provided by the Curate and the Church-wardens at the charges of the Parish.*

the minister to neglect the usual and daily sacrifice of the Church, by which all people, whether they be there or no, reap so much benefit. And this was the opinion of my lord and master, Dr. Overall." [Works, v. 127.] Yet the "four, or three at the least" was written in a slightly varied form of the rubric which he inserted in the Durham volume. Perhaps it is one of those rules to which exceptions may sometimes be made under the wise law, "Charity is above rubrics."

in Cathedral and Collegiate Churches, and Colleges] The word "Colleges" was inserted by Cosin, who also erased the words "except they shall have a reasonable cause to the contrary," and inserted after "Sunday" "or once in the month." It is to be hoped that the next generation will be entirely without experience of "Cathedrals, Collegiate Churches, or Colleges" where this rule of a weekly celebration is transgressed.

it shall suffice that the Bread] This rubric stood thus in the Prayer Book of 1549:—"For avoiding of all matters and occasion of dissension, it is meet that the bread prepared for the Communion be made, through all this realm, after one sort and fashion: that is to say, unleavened, and round, as it was afore, but without all manner of print, and something more larger and thicker than it was, so that it may be aptly divided in divers pieces: and every one shall be divided in two pieces, at the least, or more, by the discretion of the minister, and so distributed. And men must not think less to be received in part than in the whole, but in each of them the whole body of our Saviour Jesu Christ." It was altered to its present form in 1552.

Bishop Cosin proposed to substitute the following:—"Concerning the Bread and Wine, the Bread shall be such as is usual: yet the best and purest that conveniently may be gotten: though wafer Bread (pure and without any figure set upon it) shall not be forbidden, especially in such churches where it hath been accustomed. The Wine also shall be of the best and purest that may be had."

This was scarcely in accordance with the interpretation put upon the existing rubric by the Elizabethan Injunctions [A.D. 1559], and by Archbishop Parker. The former directs as follows:—"Item, Where also it was in the time of K. Edward the Sixth used to have the Sacramental bread of common fine bread, it is ordered for the more reverence to be given to these holy mysteries, being the Sacraments of the body and blood of our Saviour Jesus Christ, that the same Sacramental bread be made and formed plain, without any figure thereupon, of the same fineness and fashion round, though somewhat bigger in compass and thickness, as the usual bread and wafer¹, heretofore named singing cakes, which served for the use of the private Masse." Archbishop Parker, when appealed to as to the meaning of the rubric, wrote, "It shall suffice, I expound, where either there wanteth such fine usual bread, or superstition be feared in the wafer-bread, they may have the Communion in fine usual bread; which is rather a toleration in these two necessities, than is in

plain ordering, as it is in the injunction." [Correspondence, p. 376.] He also wrote to Sir Wm. Cecil, "As you desired, I send you here the form of the bread used, and was so appointed by order of my late Lord of London" [Grindal] "and myself, as we took it not disagreeable to the injunction. And how so many churches have of late varied I cannot tell; except it be the practice of the common adversary the devil, to make variance and dissension in the Sacrament of unity." [Ibid. 378.] Parker was also consulted by Parkhurst, Bishop of Norwich, on the subject. He first referred him to the rubric and Injunction, and in a subsequent letter wrote, "I trust that you mean not universally in your diocese to command or wink at the loaf-bread, but, for peace and quietness, here and there to be contented therewith." [Ibid. 460.] In his Visitation Articles, Parker also inquired, "And whether they do use to minister the Holy Communion in wafer-bread, according to the Queen's Majesty's Injunctions?"

Thus the contemporary interpretation of the rubric was plainly that the Sacramental Bread was usually to be in the form of wafers, but that for peace and quietness' sake, where wafers were objected to, "the best and purest Wheat Bread that may conveniently be gotten" might be permitted. Such an interpretation was also given to the rubric by the practice of learned men like Andrewes, by the custom of Westminster Abbey, the Royal Chapels, and the practice of learned Clergymen, such as Burton, author of the Anatomy of Melancholy, who was Vicar of St. Thomas', Oxford.

In the Oriental Church fermented or leavened bread is used: but the general practice of the Western Church has been to use bread prepared without fermentation, as being purer.

And if any of the Bread and Wine remain unconsecrated] This is a recognition of the right which the Christian Ministry has to "live by the altar." See 1 Cor. ix. 4-14. Gal. vi. 6.

but if any remain of that which was consecrated] These words were inserted by Bishop Cosin. They bear important testimony as to the opinion held by the Revisers of 1661 in respect to the effect of consecration. Some remarks on the Reservation of the Holy Eucharist for the use of the Sick will be found at p. 289.

shall be provided . . . at the charges of the Parish] In the Primitive Church the Elements were offered by the people, probably in successive order, the bread being taken from that which was offered for the love-feasts. In some churches of France this very ancient custom is still kept up, under the name of "*l'offrandre*." Large circular cakes of bread, surrounded by lighted tapers, are, during the offertory, carried on a sort of bier by two deacons or sub-deacons from the west end of the Church up to the Altar, and after being blessed (hence called *pain béni*) and cut up into small pieces are carried round in a basket and distributed among the congregation. A similar relic of the Primitive Church is maintained at Milan, where ten bedesmen and two aged women form a community for the purpose; two of whom, vested in black and white mantles, carry the Oblations up to the choir, where they are received by the Deacon.

In all the ancient Bidding Prayers of the Church of England there is a clause, "ye shall pray for him or her that this day gave the holy bread," or "the bread to be made holy bread of," "and

¹ Cardwell prints "water," after Sparrow; but this seems to have been a printer's error.

¶ *And note, that every Parishioner shall communicate at the least three times in the year, of which Easter to be one. And yearly at Easter every Parishioner shall reckon with the Parson, Vicar, or Curate, or his or their Deputy or Deputies; and pay to them or him all Ecclesiastical Duties, accustomedly due, then and at that time to be paid.*

¶ *After the Divine Service ended, the money given at the Offertory shall be disposed of to such pious and charitable uses, as the Minister and Church-wardens shall think fit. Wherein if they disagree, it shall be disposed of as the Ordinary shall appoint.*

WHEREAS it is ordained in this Office for the Administration of the Lord's Supper, that the Communicants should receive the same kneeling; (which Order is well meant, for a signification of our humble and grateful acknowledgement of the benefits of Christ therein given to all worthy Receivers, and for the avoiding of such profanation and disorder in the holy Communion, as might otherwise ensue) Yet, lest the same Kneeling should by any persons, either out of ignorance and infirmity, or out of malice and obstinacy, be misconstrued and depraved; It is here declared, That thereby no adoration is intended, or ought to be done, either unto the Sacramental Bread or Wine there bodily received, or unto any Corporal Presence of Christ's natural Flesh and Blood. For the Sacramental Bread and Wine remain still in their very Natural Substances, and therefore may not be adored, (for that were Idolatry, to be abhorred of all faithful Christians) and the Natural Body and Blood of our Saviour Christ are in Heaven, and not here; it being against the truth of Christ's Natural Body to be at one time in more places than one.

for him that first began and longest holdeth on, that God reward it him at the day of doom;" from which it may be seen (as from much other evidence) that this custom of the blessed bread maintained its hold in England as late, at least, as the sixteenth century. It was discontinued because the bread so blessed was superstitiously regarded by many ignorant persons as equivalent to the Holy Sacrament itself.

The present rubric *may* be considered as an adaptation of this custom, but it is quite certain that the wafers for consecration must always have been provided under the special direction of the clergy, though certainly at the cost of the Parish.

The 20th Canon provides that the wine shall be brought to the Altar in a metal flagon or cruet, of pewter or silver, thus forbidding any domestic vessel such as a glass bottle.

the money . . . shall be disposed of] This rubric was added in 1661. It is a modification of the following, which was the one proposed by Bishop Cosin:—

“¶ *After the Divine Service ended, the money which was offered shall be divided, one half to the Priest*” [erasure, “to provide him books of Divinity”], “*the other half to be employed to some pious or charitable use for the decent furnishing of the Church, or the relief of the poor, among whom it shall be distributed if need require, or put into the poor man's box at the discretion of the Priest and Church-wardens, or other officers of the place that are for that purpose appointed.*”

This was substantially taken from the Scottish book of 1637: and offers some guide as to the purposes to which it was intended that the Offertory money should be applied.

THE DECLARATION ON KNEELING.

This Declaration was first added to the Communion Office at

the last Revision in 1661. It was framed, though with a most important difference in the wording, from the Declaration which, as a sort of afterthought, was inserted in the majority but not in all of the copies of the Prayer Book issued in 1552 [see p. xxxii]. This affirmed that “no adoration was done or ought to be done, either unto the Sacramental Bread or Wine there bodily received, or unto any *real and essential* presence there being of Christ's natural Flesh and Blood.” It was probably framed by Cranmer, and intended merely [see the Rev. T. W. Perry's exhaustive volume entitled “The Declaration on Kneeling”] as a protest against the doctrine of Transubstantiation, and the low notion of a carnal presence which had come to be the interpretation too commonly put on the phrase “real and essential presence.” The Declaration of 1552 was “signed by the King,” [Strype's Cranmer, bk. ii. ch. 33.] but it was never ratified by the Church, and is wanting in all editions of the Prayer Book from Elizabeth's Accession to the Restoration. At the Savoy Conference the Presbyterians desired its restoration. The Bishops replied, “This rubric is not in the Liturgy of Queen Elizabeth, nor confirmed by law; nor is there any great need of restoring it, the world being now in more danger of profanation than of idolatry. Besides the sense of it is declared sufficiently in the 28th Article of the Church of England.” [Cardw. Conferences, p. 354.] Whilst partly adopting it, the Revisers of 1661 (under the influence, as it seems, of Bp. Gauden, probably at the suggestion of the venerable Gunning) made the important change of substituting the word “corporal” for the words “real and essential.” Thus they retained the protest against Transubstantiation, whilst they removed all risk of the Declaration, or “Black rubric” as it was sometimes called, being misunderstood as even an apparent denial of the truth of the Real Presence.

APPENDIX TO THE COMMUNION OFFICE.

[L.]

THE ANCIENT LITURGY OF THE CHURCH OF ENGLAND, ACCORDING TO THE USE OF SARUM.

THE Priest, having first confessed and received Absolution, said the Hymn, "Veni, Creator," whilst putting on the holy vestments, and then the Collect, "Deus, cui omne cor patet," Ps. xliii. *Judica me*, with the Antiphon, "Introibo ad altare Dei, ad Deum qui lætificat juventutem meam;" followed by "Kyrie," "Pater noster," and "Ave Maria." All this, apparently, was done in the Sacristy.

The "Officium," or Introit, having been begun, the Priest proceeded "ad gradum Altaris," and there, (with the Deacon on the right and the Sub-deacon on the left side of the Altar,) said "Confiteor," &c.; to which they responded with "Misereatur," &c. Then they said the "Confiteor," and the Priest responded with "Misereatur," and "Absolutionem."

He then kissed the Deacon and Sub-deacon, saying "Habete osculum pacis et dilectionis, ut apti sitis sacrosancto altari, ad perficiendum officia Divina;" and then going up to the altar, and standing before the midst of it, said secretly, "Take from us, we beseech Thee, O Lord, all our iniquities, that we may with pure minds enter in unto the Holy of Holies. Through Christ our Lord." He then signed himself with the cross in his forehead, saying, "In the Name of the Father, and of the Son, and of the Holy Ghost. Amen."

Then, taking the censer from the Deacon, he censed the Altar in the middle and at each horn, and gave it back to the Deacon, who censed him.

All this was done during the singing of the Introit by the Choir. Then, after "Kyrie Eleison," &c., the Priest, standing before the midst of the Altar, presented the "Gloria in excelsis Deo;" after which he returned to the "dexter horn" of the altar, for according to Sarum Use, the Priest, having gone to the "dexter horn" after the "Aufer a nobis," remained there until the Epistle, or, if assisted by Epistoler and Gospeller, until the Creed, *excepting only* when he had to present the "Gloria in Excelsis".

Then the Priest, having crossed himself on the forehead, turned to the People with Ψ . The Lord be with you. *Ry.* And with thy spirit. Then, turning to the altar, he said the Collect.

The Sub-deacon then going from the Altar through the Choir, read the Epistle, sometimes from a pulpit, sometimes from the step of the Choir; after which the Gradale, and Alleluia, and sometimes a Sequence or Tractus were sung.

Then the Deacon, having first censed the middle of the Altar, went down through the Choir, preceded by the two taper-bearers and the censer-bearer, and read the Gospel from the same place from which the Epistle had been read, the Sub-deacon holding

the Book, the taper-bearers one on each side, and the censer-bearer behind him. After the announcement of the Gospel the Choir turned to the Altar and sang "Glory be to Thee, O Lord;" but during the reading of the Gospel they turned towards the reader. The Gospel finished, the Deacon kissed the Book, and taking it from the Sub-deacon, carried it back in front of his breast, and the Priest, moving to the midst of the Altar, presented the first words of the Creed, "I believe in one God." The Sarum Use directs the Choir to turn to the Altar at the Creed, and to bow, 1. at "And was incarnate;" 2. at "And was made man;" 3. at "And was crucified."

After the Creed, the Priest, saying first "The Lord be with you," said the "Offertory," which consisted of a few verses of Holy Scripture, most frequently from the Psalms.

After the "Offertory" the Deacon handed to the Priest the Chalice containing wine and water, and upon it the Paten containing some bread. The Priest then raised the Chalice slightly in both hands, "offerens sacrificium Domino," and saying the prayer, "Suscipe, Sancta Trinitas, hanc oblationem quam ego indignus peccator offero in honore tuo, beatæ Mariæ et omnium Sanctorum tuorum, pro peccatis et offensivibus meis: et pro salute vivorum et requie omnium fidelium defunctorum. In Nomine Patris et Filii et Spiritus Sancti acceptum sit omnipotenti Deo hoc sacrificium novum." He then replaced the Chalice and Paten and Bread upon the Altar, and covered them with the Corporale; and taking the censer from the Deacon, censed the oblations, saying, "Let my prayer, O Lord, be set forth in Thy sight as the incense." Then the Deacon censed the Priest, and an acolyte censed the Choir.

Then the Priest going to the "right horn" of the Altar washed his hands, saying, "Cleanse me, O Lord, from all defilement of mind and body, that I may be able with purity to fulfil the holy work of the Lord." Then, returning to the midst of the Altar, he bowed, and said, "In the spirit of humility and with contrite hearts may we be accepted of Thee, O Lord; and may our offering be so made in Thy sight, that it may be accepted of Thee this day, and may please Thee, O Lord my God."

Then, crossing himself "In the Name," &c. and turning to the people, he said, "Pray, brethren and sisters, for me, that this my sacrifice, which is also equally yours, may be accepted by our Lord God:" and the Clerks answered, "The grace of the Holy Spirit enlighten thy heart and thy lips, and the Lord graciously accept this sacrifice of praise at thy hands for our sins and offences."

Turning back to the Altar, the Priest then said the "Secretæ," corresponding in number to the Collects said before the Epistle; and again saluting the People with "The Lord be with you," began the Anaphora, or more solemn part of the Communion Service, which was as follows:

Priest. Lift up your hearts.

Answer. We lift them up unto the Lord.

Priest. Let us give thanks unto our Lord God.

Answer. It is meet and right so to do.

¹ The "Gloria in Excelsis" was not said during Advent, nor from Septuagesima to Easter Eve.

Priest. It is very meet, right, and our bounden duty, that we should at all times, and in all places, give thanks unto Thee, O Lord, holy Father, Almighty everlasting God: through Christ our Lord. Through whom the Angels praise Thy Majesty, Dominions adore Thee, and Powers tremble before Thee. The Heavens, and all the Hosts of them, and the blessed Seraphim, together in united exultation praise Thee. With whom we pray that Thou wouldst command our voices also to be admitted, evermore humbly praising Thee and saying:

Holy, Holy, Holy, Lord God of Hosts: heaven and earth are full of Thy glory: Hosanna in the highest. Blessed is He that cometh in the Name of the Lord: Hosanna in the highest.

[Then immediately, joining his hands and raising his eyes, he began the Canon of the Mass, as follows,]

Most merciful Father, we humbly beseech Thee, through Jesus Christ Thy Son our Lord, that Thou wouldst accept and bless these gifts, these offerings, these holy undefiled sacrifices,

Which, before all things, we offer unto Thee for Thy holy Catholic Church, which do Thou vouchsafe to keep in peace and unity, and to rule and govern it throughout the world, as also Thy servant N. our Pope, and N. our Bishop, and N. our King, and all orthodox believers of the Catholic and Apostolic Faith.

Remember, O Lord, Thy servants and Thy handmaidens, N. and N., and all here present, whose faith and devotion are known unto Thee: for whom we offer unto Thee, and who themselves also do offer unto Thee, this sacrifice of praise, for themselves and all their friends, for the redemption of their own souls and the hope of their own salvation and deliverance, and who pay their vows to Thee, the eternal, living, and true God:

In communion with, and having in devout remembrance, first, the glorious and Ever-Virgin Mary, Mother of Jesus Christ our Lord and God, as well as also Thy blessed Apostles and Martyrs, Peter, Paul, Andrew, James, John, Thomas, James, Philip, Bartholomew, Matthew, Simon, and Thaddeus: Linus, Cletus, Clemens, Sixtus, Cornelius, Cyprian, Laurence, Chrysgonus, John and Paul, Cosmas and Damian; and all Thy Saints: by whose merits and prayers do Thou grant, that we may evermore be defended by the help of Thy protection. Through the same Christ our Lord. Amen.

This oblation therefore of us Thy humble servants, as well as of Thy whole family, we pray that Thou, O Lord, wouldst favourably receive; and wouldst dispose our days in Thy peace, and deliver us from eternal damnation, and make us to be numbered with the flock of Thine elect. Through Christ our Lord. Amen.

Which oblation do Thou, O God Almighty, vouchsafe to make altogether blessed, meet, and right, reasonable, and acceptable, that to us it may become the body and blood of Thy most dearly beloved Son, our Lord Jesus Christ. *[Here the Priest raised the Host saying,]*

Who the day before He suffered, took bread into His holy and venerable hands, and lifting up His eyes to heaven, *[here he raised his eyes,]* to Thee, O God, His Father Almighty, and giving thanks to Thee, He blessed, and brake it, and *[here he touched the Host]* gave it to His disciples, saying, Take and eat ye all of this, For this is My Body. *[After these words the Priest bowed himself towards the Host, and then raised it above his forehead that it might be seen by the people, and then reverently replaced it in front of the Chalice. He then uncovered the Chalice, and taking it in his hands, said,]*

In like manner after they had supped, taking also this noble cup into His holy and venerable hands, and giving thanks to Thee, He blessed it, and gave it to His disciples, saying, Take and drink ye all of this. *[Here he raised the Chalice slightly, saying,]*

For this is the cup of My Blood of the new and everlasting covenant, the mystery of faith, which shall be shed for you and for many for the remission of sins. *[Here he raised the Chalice to his breast, or above his head, saying,]*

As oft as ye shall do this, ye shall do it in remembrance of Me. *[Here he replaced the Chalice on the Altar, and covered it.]*

Wherefore, O Lord, in memory of the same Thy Son Christ

our Lord and God, of His blessed Passion as well as of His Resurrection from the grave and glorious Ascension into Heaven, we Thy servants, and also Thy holy people, offer to Thine illustrious Majesty of Thine own gifts which Thou hast given, a pure offering, an holy offering, an undefiled offering, even the holy bread of eternal life, and the cup of everlasting salvation.

Upon which vouchsafe to look with favourable and propitious countenance, and to accept, as Thou vouchsafedst to accept the gifts of Thy righteous servant Abel, and the Sacrifice of our Patriarch Abraham, and that which Thy High Priest Melchisedech offered unto Thee, a holy sacrifice, an offering undefiled.

We humbly beseech Thee, Almighty God, command these to be carried by the hands of Thy holy angel to Thine altar on high, in the sight of Thy Divine Majesty, that as many of us as by partaking of this altar have received the holy body and blood of Thy Son, may be fulfilled with Thy grace and heavenly benediction. Through the same Christ our Lord. Amen.

Remember also, O Lord, the souls of Thy servants and handmaids N. and N. who have gone before us with the sign of faith, and now do sleep in the sleep of peace: to them, O Lord, and to all that are at rest in Christ, grant, we beseech Thee, a place of refreshment, of light and peace. Through the same Christ our Lord. Amen.

To us sinners also Thy servants, who trust in the multitude of Thy mercies, vouchsafe to give some portion and fellowship with Thy holy Apostles and Martyrs, with John, Stephen, Matthias, Barnabas, Ignatius, Alexander, Marcellinus, Peter, Felicitas, Perpetua, Agatha, Lucy, Agnes, Cecilia, Anastasia, and with all Thy Saints, into whose company do Thou, we beseech Thee, admit us, not weighing our merits, but pardoning our offences. Through Christ our Lord.

Through Whom, O Lord, Thou evermore createst all these good things, sanctifiest, quickenest, blessdest them, and givest them to us.

Through Him, and with Him, and in Him, in the unity of the Holy Ghost, all honour and glory be unto Thee, O God, the Father Almighty, world without end. Amen.

Let us pray.

Taught by His wholesome precepts, and guided by His divine instruction, we are bold to say:

[Here the Deacon took the Paten, and, standing on the right of the Priest, raised it up on high uncovered, and held it so, to the words, Grant, of Thy mercy, peace in our days.]

The Priest meantime raising his hands, said:]

Our Father, &c.

Choir. But deliver us from evil.

Priest, secretly. Amen.

Deliver us, we beseech Thee, O Lord, from all evils, past, present, and future: and, the blessed and glorious and Ever-Virgin Mary, the Mother of God, and Thy blessed Apostles, Peter and Paul and Andrew, and all Thy saints, interceding for us,

[Here the Deacon gave the Paten to the Priest, who, first making the sign of the cross with it in front of himself, placed it on the Altar, saying,]

Grant of Thy mercy peace in our days, that we being aided by the help of Thy mercy, may evermore be both free from sin, and also secure from all disturbance.

[Here the Priest uncovered the Chalice, and, bowing reverently, took the Host, and, holding it with his thumbs and forefingers over the Chalice, broke it into three parts; saying, at the first breaking,]

Through the same Thy Son, Jesus Christ our Lord.

At the second,

Who liveth and reigneth with Thee, in the unity of the Holy Ghost, ever one God.

And then, holding two portions in his left hand, and the third in his right hand over the top of the Chalice, aloud,

World without end.

Choir. Amen.

Priest. The peace of the Lord be with you evermore.

Choir. And with thy spirit.

[Then the Priest, with the Deacon and Sub-deacon, said,]

O Lamb of God, That takest away the sins of the world : Have mercy upon us.

O Lamb of God, That takest away the sins of the world : Have mercy upon us.

O Lamb of God, That takest away the sins of the world : Grant us Thy peace.

Or, in Masses for the departed,

O Lamb of God, That takest away the sins of the world : Grant them rest.

Adding eternal at the third repetition.

[Then the Priest dipped the third portion of the Host into the sacrament of the blood, making the sign of the cross, and saying,]

May this hoxly commingling of the body and blood of our Lord Jesus Christ be to me and to all who receive it health of mind and body, and a healthful preparation towards the attainment of everlasting life. Through the same Christ our Lord. Amen.

[Before giving the Peace, the Priest said,]

O Lord, holy Father, Almighty everlasting God, Grant me so worthily to receive this holy body and blood of Thy Son Jesus Christ our Lord, that I may thereby receive the remission of all my sins, and be filled with Thy Holy Ghost, and have Thy peace; for Thou art God alone, and beside Thee there is none else, Whose glorious kingdom and dominion endureth evermore, world without end. Amen.

Priest, to the Deacon. Peace be to thee, and to the Church of God.

Answer. And with thy spirit.

[Before communicating, the Priest, holding the Host with both hands, said these private prayers :]

O God the Father, the source and origin of all goodness, Who moved by pity didst will that Thine Only-begotten should descend to the lower parts of the earth and take flesh, which I unworthy hold here in my hands, [bowing to the Host,] I adore Thee, I glorify Thee, I praise Thee with the whole intention of my mind and heart, and pray that Thou wouldst not forsake us Thy servants, but wouldst forgive our sins, that we may be able to serve Thee, the only living and true God, with pure heart and chaste body. Through the same Christ our Lord. Amen.

O Lord Jesu Christ, Son of the living God, Who by the will of the Father and the co-operation of the Holy Ghost, hast by Thy death given life unto the world : Deliver me, I beseech Thee, by this Thy holy body and blood from all my iniquities and from all evils; and make me to be always obedient unto Thy commandments, and suffer me not to be separated from Thee for ever, O Saviour of the world, Who with the Father and the same Holy Ghost livest and reignest ever one God, world without end. Amen.

May the sacrament of Thy body and blood, O Lord Jesu Christ, which, although unworthy, I receive, be not unto me for judgment and condemnation; but of Thy pity be profitable unto me for salvation both of body and soul. Amen.

[Then, with an act of humble reverence he said, before receiving,]

Hail evermore, most holy flesh of Christ, to me before and above all things the sum of delight. May the body of our Lord Jesus Christ be unto me a sinner the way and the life.

In the Name of the Father, and of the Son, and of the Holy Ghost. Amen.

[Here he took the body, first making a cross with it before his mouth. Then with humble reverence and devotion towards the blood, he said :]

Hail evermore, heavenly drink of Jesus' blood, to me before and above all things the sum of delight. May the body and blood of our Lord Jesus Christ be profitable to me a sinner for an everlasting remedy unto eternal life. Amen.

In the Name of the Father, and of the Son, and of the Holy Ghost. Amen.

[Here he took the blood; and then bending himself, said with devotion the following prayer :]

I yield Thee thanks, O Lord, holy Father, Almighty everlast-

ing God, Who hast refreshed me with the most holy body and blood of Thy Son our Lord Jesus Christ; and I pray that this sacrament of our salvation, which I, an unworthy sinner, have received, may not come into judgment or condemnation against me according to my deserts, but may be for the advancement of my soul and body unto life eternal. Amen.

[Then followed immediately the cleansing of the vessels, the Priest carrying the Chalice to the "dexter horn" of the Altar, and the Sub-deacon pouring in the wine and water. After this the following prayers were said,]

That which outwardly with our mouth we have taken, grant, Lord, we may with pure mind inwardly receive; and may the gift vouchsafed in this life be to us a healing remedy unto that which is to come.

Lord, may this communion cleanse us from sin, and make us partakers of Thy heavenly blessings.

[The Priest then washed his hands, the Deacon in the mean time folding the Corporals. After which the Priest with his assistants said the "Communion," (usually a verse from a Psalm,) and after that the Post-communion collect or collects, followed by the "Ite, missa est" to mark the conclusion of the service. He then, standing before the midst of the altar, with his body inclined and his hands joined, said secretly,]

O Holy Trinity, may this my humble duty and service be pleasing unto Thee: and grant that this sacrifice which I unworthily have offered before the eyes of Thy Majesty, may of Thy mercy be favourably accepted by Thee, for myself and for all those for whom I have offered it: Who livest and reignest, ever one God, world without end. Amen.

[This done, he raised himself, signed the Cross upon his forehead, with the words, In the Name, &c., and left the Altar, saying, as he went, the first fourteen verses of the Gospel according to St. John.]

[II.]

THE FIRST VERNACULAR LITURGY OF THE CHURCH OF ENGLAND.

A.D. 1549.

The Supper of the Lord, and the Holy Communion, commonly called the Mass.

* * * * *

The Priest standing humbly afore the midst of the Altar, shall say the Lord's Prayer, with this Collect.

Almighty God, unto whom all hearts be open, and all desires known, and from whom no secrets are hid: Cleanse the thoughts of our hearts, by the inspiration of Thy Holy Spirit: that we may perfectly love Thee, and worthily magnify Thy holy Name: through Christ our Lord. Amen.

Then shall he say a Psalm appointed for the Introit; which Psalm ended, the Priest shall say, or else the Clerks shall sing,

iii. Lord, have mercy upon us.

iii. Christ, have mercy upon us.

iii. Lord, have mercy upon us.

Then the Priest standing at God's board shall begin, Glory be to God on high.

The Clerks. And in earth peace, good will towards men, &c.

Then the Priest shall turn him to the people, and say,

The Lord be with you.

The Answer. And with thy spirit.

The Priest. Let us pray.

Then shall follow the Collect of the day, with one of these two Collects following for the King. [Collects the same as at present.]

The Collects ended, the Priest, or he that is appointed, shall read the Epistle, in a place assigned for the purpose, saying, The Epistle of St. Paul, written in the Chapter of to the

The Minister then shall read the Epistle. Immediately after

the Epistle ended, the Priest, or one appointed to read the Gospel, shall say,

The holy Gospel, written in the Chapter of

*The Clerks and people shall answer,
Glory be to Thee, O Lord.*

*The Priest or Deacon then shall read the Gospel: After the Gospel ended, the Priest shall begin,
I believe in one God.*

The Clerks shall sing the rest.

After the Creed ended, shall follow the Sermon or Homily, or some portion of one of the Homilies, as they shall be hereafter divided: wherein if the people be not exhorted to the worthy receiving of the holy Sacrament of the body and blood of our Saviour Christ, then shall the Curate give this exhortation, to those that be minded to receive the same.

Dearly beloved in the Lord, ye that mind to come, &c.

In Cathedral churches or other places, where there is daily Communion, it shall be sufficient to read this exhortation above written, once in a month. And in parish churches, upon the week-days it may be left unsaid.

And if upon the Sunday or holyday the people be negligent to come to the Communion: Then shall the Priest earnestly exhort his parishioners, to dispose themselves to the receiving of the Holy Communion more diligently, saying these or like words unto them.

Dear friends, and you especially upon whose souls I have cure and charge, on next, I do intend, by God's grace, to offer to all such as shall be godly disposed, the most comfortable Sacrament of the body and blood of Christ, &c.

Then shall follow for the Offertory one or more of these Sentences of Holy Scripture, to be sung whiles the people do offer, or else one of them to be said by the Minister, immediately afore the offering.

Let your light so shine before men, that they may see your good works, and glorify your Father which is in heaven. *Matt. v.*

Lay not up for yourselves, &c.

Where there be Clerks, they shall sing one, or many of the sentences above written, according to the length and shortness of the time, that the people be offering.

In the mean time, whiles the Clerks do sing the Offertory, so many as are disposed shall offer to the poor men's box every one according to his ability and charitable mind. And at the offering days appointed, every man and woman shall pay to the Curate the due and accustomed offerings.

Then so many as shall be partakers of the Holy Communion shall tarry still in the quire, or in some convenient place nigh the quire, the men on the one side, and the women on the other side. All other (that mind not to receive the said Holy Communion) shall depart out of the quire, except the Ministers and Clerks.

Then shall the Minister take so much Bread and Wine, as shall suffice for the persons appointed to receive the Holy Communion, laying the Bread upon the Corporas, or else in the Paten, or in some other comely thing prepared for that purpose: And putting the Wine into the Chalice, or else in some fair or convenient cup, prepared for that use (if the Chalice will not serve), putting thereto a little pure and clean water: And setting both the Bread and Wine upon the Altar: Then the Priest shall say,

The Lord be with you.

Answer. And with thy spirit.

Priest. Lift up your hearts.

Answer. We lift them up unto the Lord.

Priest. Let us give thanks to our Lord God.

Answer. It is meet and right so to do.

The Priest. It is very meet, right, and our bounden duty

that we should at all times, and in all places, give thanks to Thee, O Lord, holy Father, Almighty everlasting God.

Here shall follow the Proper Preface, according to the time (if there be any specially appointed), or else immediately shall follow,

Therefore with Angels, &c.

PROPER PREFACES

[as at present].

After which Preface shall follow immediately,

Therefore with Angels and Archangels, and with all the holy company of heaven, we laud and magnify Thy glorious Name, evermore praising Thee, and saying,

Holy, Holy, Holy, Lord God of Hosts: heaven and earth are full of Thy glory: Hosanna in the highest. Blessed is He that cometh in the Name of the Lord: Glory to Thee, O Lord, in the highest.

This the Clerks shall also sing.

When the Clerks have done singing, then shall the Priest, or Deacon, turn him to the people, and say,

Let us pray for the whole state of Christ's Church.

Then the Priest, turning him to the Altar, shall say or sing, plainly and distinctly, this prayer following:

Almighty and everliving God, which by Thy holy Apostle hast taught us to make prayers and supplications, and to give thanks for all men: We humbly beseech Thee most mercifully to receive these our prayers, which we offer unto Thy Divine Majesty, beseeching Thee to inspire continually the universal Church with the spirit of truth, unity, and concord: And grant that all they that do confess Thy holy Name, may agree in the truth of Thy holy Word, and live in unity and godly love. Specially we beseech Thee to save and defend Thy servant Edward our King, that under him we may be godly and quietly governed. And grant unto his whole Council, and to all that be put in authority under him, that they may truly and indifferently minister justice, to the punishment of wickedness and vice, and to the maintenance of God's true religion and virtue. Give grace (O heavenly Father) to all Bishops, Pastors, and Curates, that they may both by their life and doctrine set forth Thy true and lively Word, and rightly and duly administer Thy holy Sacraments: and to all Thy people give Thy heavenly grace, that with meek heart and due reverence they may hear and receive Thy holy Word, truly serving Thee in holiness and righteousness all the days of their life. And we most humbly beseech Thee of Thy goodness (O Lord) to comfort and succour all them, which in this transitory life be in trouble, sorrow, need, sickness, or any other adversity. And especially we commend unto Thy merciful goodness this congregation which is here assembled in Thy name, to celebrate the commemoration of the most glorious death of Thy Son: And here we do give unto Thee most high praise, and hearty thanks, for the wonderful grace and virtue, declared in all Thy Saints, from the beginning of the world: And chiefly in the glorious and most blessed Virgin Mary, mother of Thy Son Jesu Christ our Lord and God, and in the holy Patriarchs, Prophets, Apostles, and Martyrs, whose examples (O Lord) and stedfastness in Thy faith, and keeping Thy holy commandments, grant us to follow. We commend unto Thy mercy (O Lord) all other Thy servants, which are departed hence from us, with the sign of faith, and now do rest in the sleep of peace: Grant unto them, we beseech Thee, Thy mercy, and everlasting peace, and that, at the day of the general resurrection, we and all they which be of the mystical body of Thy Son, may altogether be set on His right hand, and hear that His most joyful voice: Come unto Me, O ye that be blessed of My Father, and possess the kingdom, which is prepared for you from the beginning of the world: Grant this, O Father, for Jesu Christ's sake, our only Mediator and Advocate.

O God, heavenly Father, which of Thy tender mercy didst give Thine only Son Jesu Christ, to suffer death upon the cross for our redemption, who made there (by His one oblation, once offered) a full, perfect, and sufficient sacrifice, oblation, and satisfaction,

for the sins of the whole world, and did institute, and in His holy Gospel command us to celebrate, a perpetual memory of that His precious death, until His coming again: Hear us (O merciful Father) we beseech Thee; and with Thy Holy Spirit and Word vouchsafe to bless and sanctify these Thy gifts, and creatures of bread and wine, that they may be unto us the body and blood of Thy most dearly beloved Son Jesus Christ: Who, in the same night that He was betrayed, took bread, and when He had blessed, and given thanks, He brake it, and gave it to His disciples, saying: Take, eat; this is My body which is given for you: do this in remembrance of Me.

Here the Priest must take the bread into his hands.

Likewise after supper He took the cup, and when He had given thanks, He gave it to them, saying: Drink ye all of this, for this is My blood of the New Testament, which is shed for you and for many, for remission of sins: do this, as oft as you shall drink it, in remembrance of Me.

Here the Priest shall take the cup into his hands.

These words before rehearsed are to be said, turning still to the Altar, without any elevation, or showing the Sacrament to the people.

Wherefore, O Lord and heavenly Father, according to the institution of Thy dearly beloved Son, our Saviour Jesu Christ, we Thy humble servants do celebrate, and make here before Thy Divine Majesty, with these Thy holy gifts, the memorial which Thy Son hath willed us to make: having in remembrance His blessed Passion, mighty Resurrection, and glorious Ascension, rendering unto Thee most hearty thanks, for the innumerable benefits procured unto us by the same, entirely desiring Thy fatherly goodness mercifully to accept this our Sacrifice of praise and thanksgiving: most humbly beseeching Thee to grant, that by the merits and death of Thy Son Jesus Christ, and through faith in His blood, we and all Thy whole Church may obtain remission of our sins, and all other benefits of His Passion. And here we offer and present unto Thee (O Lord) ourself, our souls, and bodies, to be a reasonable, holy, and lively sacrifice unto Thee: humbly beseeching Thee, that whosoever shall be partakers of this Holy Communion, may worthily receive the most precious body and blood of Thy Son Jesus Christ, and be fulfilled with Thy grace and heavenly benediction, and made one body with Thy Son Jesus Christ, that He may dwell in them, and they in Him. And although we be unworthy (through our manifold sins) to offer unto Thee any sacrifice: yet we beseech Thee to accept this our bounden duty and service, and command these our prayers and supplications, by the ministry of Thy holy Angels, to be brought up into Thy holy Tabernacle before the sight of Thy Divine Majesty; not weighing our merits, but pardoning our offences, through Christ our Lord; by Whom, and with Whom, in the unity of the Holy Ghost, all honour and glory be unto Thee, O Father Almighty, world without end. *Amen.*

Let us pray.

As our Saviour Christ hath commanded and taught us, we are bold to say, Our Father, which art in heaven, hallowed be Thy Name. Thy kingdom come. Thy will be done in earth, as it is in heaven. Give us this day our daily bread. And forgive us our trespasses, as we forgive them that trespass against us. And lead us not into temptation.

The Answer. But deliver us from evil. *Amen.*

Then shall the Priest say,

The peace of the Lord be always with you.

The Clerks. And with thy spirit.

The Priest. Christ our Paschal Lamb is offered up for us, once for all, when He bare our sins on His body upon the cross; for He is the very Lamb of God, that taketh away the sins of the world: wherefore let us keep a joyful and holy feast with the Lord.

Here the Priest shall turn him toward those that come to the Holy Communion, and shall say,

You that do truly and earnestly repent you of your sins to Almighty God, and be in love and charity with your neighbours,

and intend to lead a new life, following the commandments of God, and walking from henceforth in His holy ways: draw near and take this Holy Sacrament to your comfort, make your humble confession to Almighty God, and to His holy Church here gathered together in His name, meekly kneeling upon your knees.

Then shall this general Confession be made, in the name of all those that are minded to receive the Holy Communion, either by one of them, or else by one of the ministers, or by the Priest himself, all kneeling humbly upon their knees.

[Here follow the Confession, the Absolution, the Comfortable Words, and the Prayer of Humble Access.]

Then shall the Priest first receive the Communion in both kinds himself, and next deliver it to other Ministers, if any be there present, (that they may be ready to help the chief Minister,) and after to the people.

And when he delivereth the Sacrament of the Body of Christ he shall say to every one these words:

The Body of our Lord Jesus Christ, which was given for thee, preserve thy body and soul unto everlasting life.

And the Minister delivering the Sacrament of the Blood, and giving every one to drink, once and no more, shall say,

The Blood of our Lord Jesus Christ, which was shed for thee, preserve thy body and soul unto everlasting life.

If there be a Deacon or other Priest, then shall he follow with the Chalice: and as the Priest ministereth the Sacrament of the body, so shall he (for more expedition) minister the Sacrament of the blood, in form before written.

In the Communion time the Clerks shall sing,

ii. O Lamb of God, that takest away the sins of the world: have mercy upon us.

O Lamb of God, that takest away the sins of the world: grant us Thy peace.

Beginning so soon as the Priest doth receive the Holy Communion, and when the Communion is ended, then shall the Clerks sing the Post-Communion.

Sentences of Holy Scripture, to be said or sung every day one, after the Holy Communion, called the Post-Communion.

If any man will follow Me, let him forsake himself, and take up his cross, and follow Me. *Matt. xvi.*

Whosoever shall endure unto the end, he shall be saved. *Mark xiii.*

Praised be the Lord God of Israel, for He hath visited and redeemed His people: therefore let us serve Him all the days of our life, in holiness and righteousness accepted before Him. *Luke i.*

Happy are those servants, whom the Lord (when He cometh) shall find waking. *Luke xii.*

Be ye ready, for the Son of Man will come at an hour when ye think not. *Luke xii.*

The servant that knoweth his master's will, and hath not prepared himself, neither hath done according to his will, shall be beaten with many stripes. *Luke xii.*

The hour cometh, and now it is, when true worshippers shall worship the Father in spirit and truth, *John iv.*

Behold, thou art made whole sin no more, lest any worse thing happen unto thee. *John v.*

If ye shall continue in My word, then are ye My very disciples, and ye shall know the truth, and the truth shall make you free. *John viii.*

While ye have light believe on the light, that ye may be the children of light. *John xii.*

He that hath My commandments, and keepeth them, the same is he that loveth Me. *John xiv.*

If any man love Me, he will keep My word, and My Father will love him, and we will come unto him, and dwell with him. *John xiv.*

If ye shall hide in Me, and My word shall abide in you, ye shall ask what ye will, and it shall be done to you. *John xv.*

Herein is My Father glorified, that ye bear much fruit, and become My disciples. *John xv.*

This is My commandment, that you love together, as I have loved you. *John xv.*

If God be on our side, who can be against us? which did not spare His own Son, but gave Him for us all. *Rom. viii.*

Who shall lay any thing to the charge of God's chosen? it is God that justifieth; who is he that can condemn? *Rom. viii.*

The night is past, and the day is at hand; let us therefore cast away the deeds of darkness, and put on the armour of light. *Rom. xiii.*

Christ Jesus is made of God, unto us, wisdom, and righteousness, and sanctifying, and redemption, that (according as it is written) He which rejoiceth, should rejoice in the Lord. *1 Cor. i.*

Know ye not that ye are the temple of God, and that the Spirit of God dwelleth in you? If any man defile the temple of God, him shall God destroy. *1 Cor. iii.*

Ye are dearly bought; therefore glorify God in your bodies, and in your spirits, for they belong to God. *1 Cor. vi.*

Be you followers of God as dear children, and walk in love, even as Christ loved us, and gave Himself for us an offering and a Sacrifice of a sweet savour to God. *Eph. v.*

Then the Priest shall give thanks to God, in the name of all them that have communicated, turning him first to the people and saying,

The Lord be with you.

The Answer. And with thy spirit.

The Priest. Let us pray.

Almighty and everliving God, we most heartily thank Thee, &c.

Then the Priest turning him to the people, shall let them depart with this blessing:

The peace of God (which passeth all understanding) keep your hearts and minds in the knowledge and love of God, and of His Son Jesus Christ our Lord: And the blessing of God Almighty, the Father, the Son, and the Holy Ghost, be amongst you and remain with you always.

Then the people shall answer,
Amen.

Where there are no clerks, there the Priest shall say all things appointed here for them to sing.

When the Holy Communion is celebrate on the work-day, or in private houses: Then may be omitted, the Gloria in Excelsis, the Creed, the Homily, and the Exhortation, beginning, Dearly beloved, &c.

[III.]

THE SCOTTISH LITURGY.

[A.D. 1764.]

In the Communion Office of the Church of Scotland, the Offertory is followed immediately by the Sursum Corda, Preface, and Sanctus. It then proceeds as follows:—

Then the Presbyter, standing at such a part of the Holy Table, as he may, with the most ease and decency, use both his hands, shall say the Prayer of Consecration, as followeth:

All glory be to Thee, Almighty God, our heavenly Father, for that Thou, of Thy tender mercy, didst give Thy only Son, Jesus Christ, to suffer death upon the cross for our redemption; Who (by His own oblation of Himself once offered) made a full, perfect, and sufficient sacrifice, oblation, and satisfaction, for the sins of the whole world, and did institute, and in His holy Gospel command us to continue, a perpetual memorial of that, His precious death and sacrifice, until His coming again.

For, in the night that He was betrayed (*here the Presbyter is to take the paten into his hands*) He took bread, and when He had given thanks (*and here to break the bread*), He brake it,

and gave it to His disciples, saying, Take, eat (*and here to lay his hands upon all the bread*), This is My Body, which is given for you: do this in remembrance of Me.

Likewise, after supper (*here he is to take the cup into his hand*), He took the cup; and when He had given thanks, He gave it to them, saying, Drink ye all of this (*and here to lay his hands upon every vessel [be it chalice or flagon] in which there is any wine to be consecrated*), for this is My Blood, of the New Testament, which is shed for you, and for many, for the remission of sins: do this, as oft as ye shall drink it, in remembrance of Me.

Wherefore, O Lord, and heavenly Father, according to the institution of Thy dearly beloved Son, our Saviour, Jesus Christ, we, Thy humble servants, do celebrate and make here, before Thy Divine Majesty, with these Thy holy gifts, which we now offer unto Thee, the memorial Thy Son hath commanded us to make; having in remembrance His blessed Passion and precious Death, His mighty Resurrection and glorious Ascension; rendering unto Thee most hearty thanks for the innumerable benefits procured unto us by the same.

And we most humbly beseech Thee, O merciful Father, to hear us, and, of Thy almighty goodness, vouchsafe to bless and sanctify, with Thy Word and Holy Spirit, these Thy gifts and creatures of Bread and Wine, that they may become the Body and Blood of Thy most dearly beloved Son.

And we earnestly desire Thy fatherly goodness, mercifully to accept this our Sacrifice of praise and thanksgiving, most humbly beseeching Thee to grant, that by the merits and death of Thy Son, Jesus Christ, and through faith in His blood, we and all Thy whole Church may obtain remission of our sins, and all other benefits of His Passion.

And here we humbly offer and present unto Thee, O Lord, ourselves, our souls and bodies, to be a reasonable, holy, and lively sacrifice unto Thee, beseeching Thee, that whosoever shall be partakers of this Holy Communion, may worthily receive the most precious Body and Blood of Thy Son, Jesus Christ, and be filled with Thy grace and heavenly benediction, and made one body with Him, that He may dwell in them, and they in Him.

And although we are unworthy, through our manifold sins, to offer unto Thee any sacrifice; yet we beseech Thee to accept this our bounden duty and service, not weighing our merits, but pardoning our offences, through Jesus Christ our Lord;

By Whom, and with Whom, in the unity of the Holy Ghost, all honour and glory be unto Thee, O Father Almighty, world without end. *Amen.*

Let us pray for the whole state of Christ's Church.

Almighty and everliving God, Who by Thy holy Apostle hast taught us to make prayers and supplications, and to give thanks for all men; We humbly beseech Thee, most mercifully to accept our alms and oblations, and to receive these our prayers, which we offer unto Thy Divine Majesty; beseeching Thee to inspire continually the universal Church with the spirit of truth, unity, and concord: and grant that all they that do confess Thy holy Name, may agree in the truth of Thy holy Word, and live in unity and godly love.

We beseech Thee to save and defend all Christian Kings, Princes, and Governors, and especially Thy servant Victoria our Queen, that under her we may be godly and quietly governed; and grant unto her whole Council, and to all who are put in authority under her, that they may truly and indifferently minister justice, to the punishment of wickedness and vice, and to the maintenance of Thy true religion and virtue.

Give grace, O heavenly Father, to all Bishops, Priests, and Deacons, that they may, both by their life and doctrine, set forth Thy true and lively Word, and rightly and duly administer Thy holy Sacraments.

And to all Thy people give Thy heavenly grace, that with meek heart and due reverence they may hear and receive Thy holy

Commemoration of the Living.

Word, truly serving Thee in holiness and righteousness, all the days of their life.

And we commend especially to Thy merciful goodness the congregation which is here assembled in Thy name, to celebrate the commemoration of the most precious death and sacrifice of Thy Son, and our Saviour, Jesus Christ.

And we most humbly beseech Thee, of Thy goodness, O Lord, to comfort and succour all those, who in this transitory life are in trouble, sorrow, need, sickness, or any other adversity.

And we also bless Thy holy Name, for all Thy servants, who having finished their course in faith, do now rest from their labours.

And we yield unto Thee most high praise, and hearty thanks, for the wonderful grace and virtue declared in all Thy Saints, who have been the choice vessels of Thy grace, and the lights of the world in their several generations: most humbly beseeching Thee, to give us grace to follow the example of their steadfastness in Thy faith, and obedience to Thy holy commandments; that at the day of the general resurrection, we, and all they who are of the mystical body of Thy Son, may be set on His right hand, and hear His most joyful voice, Come, ye blessed of My Father, inherit the kingdom prepared for you from the foundation of the world.

Grant this, O Father, for Jesus Christ's sake, our only Mediator and Advocate. Amen.

Then shall the Presbyter say,

As our Saviour Christ hath commanded and taught us, we are bold to say, Our Father, &c.

Then the Presbyter shall say to them that come to receive the Holy Communion, this invitation:

Ye that do truly and earnestly, &c.

[Then follow the Confession, the Absolution, the Comfortable Words, and the Collect of Humble Access, as in the English Office.]

Then shall the Bishop, if he be present, or else the Presbyter that celebrateth, first receive the Communion in both kinds himself, and next deliver it to other Bishops, Presbyters, and Deacons, (if there be any present,) and after to the people in due order, all humbly kneeling. And when he receiveth himself, or delivereth the Sacrament of the Body of Christ to others, he shall say,

The Body of our Lord Jesus Christ, which was given for thee, preserve thy body and soul unto everlasting life.

Here the person receiving shall say, Amen.

And the Presbyter or Minister that receiveth the Cup himself, or delivereth it to others, shall say this Benediction,

The Blood of our Lord Jesus Christ, which was shed for thee, preserve thy body and soul unto everlasting life.

Here the person receiving shall say, Amen.

If the consecrated bread or wine be all spent before all have communicated, the Presbyter is to consecrate more, according to the form before prescribed, beginning at the words, All glory be to Thee, &c., and ending with the words, that they may become the Body and Blood of Thy most dearly beloved Son.

When all have communicated, he that celebrates shall go to the Lord's Table, and cover with a fair linen cloth that which remaineth of the consecrated elements, and then say,

Having now received the precious Body and Blood of Christ, let us give thanks to our Lord God, who hath graciously vouchsafed to admit us to the participation of His holy Mysteries; and let us beg of Him grace to perform our vows, and to persevere in our good resolutions; and that, being made holy, we may obtain everlasting life, through the merits of the all-sufficient Sacrifice of our Lord and Saviour Jesus Christ.

Then the Presbyter shall say this Collect of Thanksgiving, as followeth.

Almighty and everliving God, we most heartily thank Thee

&c. [And the Office closes with the "Gloria in Excelsis," the Peace, and the Blessing, as in the English Use.]

[IV.]

THE AMERICAN LITURGY.

The order and arrangement of the Communion Office of the American Church is the same as our own, with this one important difference, viz. that the Prayer of Oblation and the Invocation have been restored to their place in immediate connexion with the Prayer of Consecration, which now closely resembles that of the Scottish Liturgy, and is as follows:—

All glory be to Thee, Almighty God, our heavenly Father, for that Thou of Thy tender mercy didst give Thine only Son Jesus Christ to suffer death upon the cross for our redemption; who made there (by His one oblation of Himself once offered) a full, perfect, and sufficient sacrifice, oblation, and satisfaction for the sins of the whole world; and did institute, and in His holy Gospel command us to continue, a perpetual memory of that His precious death and sacrifice until His coming again: For in the night in which He was betrayed, (a) He took bread; and when He had given thanks, (b) He brake it, and gave it to His disciples, saying, Take, eat; (c) this is My Body, which is given for you; do this in remembrance of Me. Likewise, after supper, (d) He took the cup; and when He had given thanks, He gave it to them, saying, Drink ye all of this; for (e) this is My Blood, of the New Testament, which is shed for you, and for many, for the remission of sin: do this, as oft as ye shall drink it, in remembrance of Me.

^a Here the Priest is to take the Paten into his hands.

^b And here to break the bread.

^c And here to lay his hand upon all the Bread.

^d Here he is to take the Cup into his hand.

^e And here he is to lay his hand upon every Vessel in which there is any Wine to be consecrated.

Wherefore, O Lord and heavenly Father, according to the institution of Thy dearly beloved Son our Saviour

The Oblation.

Jesus Christ, we, Thy humble servants, do celebrate and make here before Thy Divine Majesty, with these Thy holy gifts, which we now offer unto Thee, the memorial Thy Son hath commanded us to make; having in remembrance His blessed Passion and precious Death, His mighty Resurrection and glorious Ascension; rendering unto Thee most hearty thanks, for the innumerable benefits procured unto us by the same. And we most humbly beseech Thee, O merciful Father, to hear us;

and, of Thy almighty goodness, vouchsafe to bless and sanctify, with Thy Word and Holy Spirit, these Thy gifts and creatures of bread and wine; that we, receiving them according to Thy Son our Saviour Jesus Christ's holy institution, in remembrance of His Death and Passion, may be partakers of His most blessed Body and Blood. And we earnestly desire Thy fatherly goodness, mercifully to accept this our Sacrifice of praise and thanksgiving; most humbly beseeching Thee to grant, that by the merits and death of Thy Son Jesus Christ, and through faith in His blood, we, and all Thy whole Church, may obtain remission of our sins, and all other benefits of His Passion. And here we offer and present unto Thee, O Lord, ourselves, our souls, and bodies, to be a reasonable, holy, and living sacrifice unto Thee; humbly beseeching Thee, that we, and all others who shall be partakers of this Holy Communion, may worthily receive the most precious Body and Blood of Thy Son Jesus Christ, be filled with Thy grace and heavenly benediction, and made one body with Him, that He may dwell in them, and they in Him. And although we are unworthy, through our manifold sins, to offer unto Thee any sacrifice; yet we beseech Thee to accept this our bounden duty and service, not weighing our merits, but pardoning our offences; through Jesus Christ our Lord; by Whom, and with Whom, in the unity of the Holy Ghost, all honour and glory be unto Thee, O Father Almighty, world without end. Amen.

Here shall be sung a Hymn, or Part of a Hymn, from the Selection for the Feasts and Fasts, &c.

[V.]

THE PRESBYTERIAN FORM.

[This presumptuous and irreverent parody of the Liturgy is reluctantly reprinted, for the sake of historical completeness, from

the "Directory" of 1644¹. When the children asked for bread, this was the stone which was provided for them during the persecution of the Church by the Puritans, from 1645 to 1661. Ed.]

Of the Celebration of the Communion, or Sacrament of the Lord's Supper.

The Communion, or Supper of the Lord, is frequently to be celebrated; but how often, may be considered and determined by the ministers, and other church-governors of each congregation, as they shall find most convenient for the comfort and edification of the people committed to their charge. And, when it shall be administered, we judge it convenient to be done after the morning sermon.

The ignorant and the scandalous are not fit to receive the sacrament of the Lord's Supper.

Where this sacrament cannot with convenience be frequently administered, it is requisite that public warning be given the Sabbath-day before the administration thereof: and that either then, or on some day of that week, something concerning that ordinance, and the due preparation thereunto, and participation thereof, be taught; that, by the diligent use of all means sanctified of God to that end, both in public and private, all may come better prepared to that heavenly feast.

When the day is come for administration, the minister, having ended his sermon and prayer, shall make a short exhortation:

"Expressing the inestimable benefit we have by this sacrament, together with the ends and use thereof: setting forth the great necessity of having our comforts and strength renewed thereby in this our pilgrimage and warfare: how necessary it is that we come unto it with knowledge, faith, repentance, love, and with hungering and thirsting souls after Christ and His benefits: how great the danger to eat and drink unworthily.

"Next, he is, in the name of Christ, on the one part, to warn all such as are ignorant, scandalous, profane, or that live in any sin or offence against their knowledge or conscience, that they presume not to come to that holy table; showing them, that he that eateth and drinketh unworthily, eateth and drinketh judgment unto himself: and, on the other part, he is in an especial manner to invite and encourage all that labour under the sense of the burden of their sins, and fear of wrath, and desire to reach unto a greater progress in grace than yet they can attain unto, to come to the Lord's table; assuring them, in the same name, of ease, refreshing, and strength to their weak and wearied souls."

After this exhortation, warning, and invitation, the table being before decently covered, and so conveniently placed, that the communicants may orderly sit about it, or at it, the minister is to begin the action with sanctifying and blessing the elements of bread and wine set before him (the bread in comely and convenient vessels, so prepared that, being broken by him, and given, it may be distributed amongst the communicants; the wine also in large cups), having first, in a few words, showed that those elements, otherwise common, are now set apart and sanctified to this holy use, by the word of institution and prayer.

Let the words of institution be read out of the Evangelists, or out of the first Epistle of the Apostle Paul to the Corinthians, chap. xi. 23, *I have received of the Lord, &c.* to the 27th verse, which the minister may, when he seeth requisite, explain and apply.

¹ "The Directory for the Public Worship of God, agreed upon by the Assembly of Divines at Westminster, with the assistance of Commissioners from the Church of Scotland, as a part of the covenanted uniformity in religion betwixt the Churches of Christ in the Kingdoms of England, Scotland, and Ireland."

Let the prayer, thanksgiving, or blessing of the bread and wine, be to this effect:

"With humble and hearty acknowledgment of the greatness of our misery, from which neither man nor angel was able to deliver us, and of our great unworthiness of the least of all God's mercies; to give thanks to God for all His benefits, and especially for that great benefit of our redemption, the love of God the Father, the sufferings and merits of the Lord Jesus Christ the Son of God, by which we are delivered; and for all means of grace, the word and sacraments; and for this sacrament in particular, by which Christ, and all His benefits, are applied and sealed up unto us, which, notwithstanding the denial of them unto others, are in great mercy continued unto us, after so much and long abuse of them all.

"To profess, that there is no other name under heaven by which we can be saved, but the name of Jesus Christ, by whom alone we receive liberty and life, have access to the throne of grace, are admitted to eat and drink at His own table, and are sealed up by His Spirit to an assurance of happiness and everlasting life.

"Earnestly to pray to God, the Father of all mercies, and God of all consolation, to vouchsafe His gracious presence, and the effectual working of His Spirit in us; and so to sanctify these elements both of bread and wine, and to bless His own ordinance, that we may receive by faith the body and blood of Jesus Christ, crucified for us, and so to feed upon Him, that He may be one with us, and we one with Him; that He may live in us, and we in Him, and to Him who hath loved us, and given Himself for us."

All which he is to endeavour to perform with suitable affections, answerable to such an holy action, and to stir up the like in the people.

The elements being now sanctified by the word and prayer, the minister, being at the table, is to take the bread in his hand, and say, in these expressions, (or other the like, used by Christ or His Apostle upon this occasion):

"According to the holy institution, command, and example of our blessed Saviour Jesus Christ, I take this bread, and, having given thanks, break it, and give it unto you; (there the minister, who is also himself to communicate, is to break the bread, and give it to the communicants;) *Take ye, eat ye; this is the body of Christ which is broken for you: do this in remembrance of Him.*"

In like manner the minister is to take the cup, and say, in these expressions, (or other the like, used by Christ or the Apostle upon the same occasion):

"According to the institution, command, and example of our Lord Jesus Christ, I take this cup, and give it unto you; (here he giveth it to the communicants;) *This cup is the new testament in the blood of Christ, which is shed for the remission of the sins of many: drink ye all of it.*"

After all have communicated, the minister may, in a few words, put them in mind

"Of the grace of God in Jesus Christ, held forth in this sacrament; and exhort them to walk worthy of it."

The minister is to give solemn thanks to God,

"For His rich mercy, and invaluable goodness, vouchsafed to them in that sacrament; and to entreat for pardon for the defects of the whole service, and for the gracious assistance of His good Spirit, whereby they may be enabled to walk in the strength of that grace, as becometh those who have received so great pledges of salvation."

The collection for the poor is so to be ordered, that no part of the public worship be thereby hindered.

AN INTRODUCTION

TO THE

OFFICES FOR HOLY BAPTISM.

THE ecclesiastical word βάπτισμα, from which our familiar English word is derived, always associates itself with the idea of purification, although such an association of ideas was not necessarily connected with the classical βαπτίζω, βάπτω, from which it is formed. On the other hand, although the original classical word has the primary sense of dipping, (that is, of more or less immersion in some fluid,) this sense is not necessarily connected with the ecclesiastical word. It is used in the New Testament with several applications: as, for example, to the baptism of the Jews by St. John the Baptist [John i. 26]; to ceremonial washings of the person and of vessels used for eating and drinking [Mark vii. 4. Heb. ix. 10]; to the ministry of our Lord [Matt. iii. 11]; to the Passion of our Lord [Luke xii. 50. Mark x. 38]; to the operation of the Holy Ghost upon the Apostles [Acts i. 5]; and, lastly, in its most customary sense, to the rite of Holy Baptism, instituted by Christ [Matt. xxviii. 19. Acts viii. 36. Eph. iv. 5. 1 Pet. iii. 21]. In all these applications of the word, the idea of purification is plainly latent, even when it is so metaphorically used as in the case of our Lord's words, "I have a baptism to be baptized with;" for although He had no sin from which He could be purified, yet was He "made sin for us," and also "made perfect through sufferings" [Heb. ii. 10]. It is moreover observable, that after the institution of the rite of Christian Baptism by our Lord, the word is not any longer used in other senses in Holy Scripture, (except historically,) but is restricted to the one which it has commonly held in all subsequent ages.

§ History of Holy Baptism.

It appears from the Holy Gospels that the ordinance of Christian Baptism was a sacramental climax which had been arrived at, and developed out of, other and inferior ordinances. St. John the Baptist prepared the way for our Lord's ministrations among the Jews by leading them to confess their sins; and this confession of their sins was followed up by a Baptism of which no further particulars are given to us than that those who received it went down into the water [Matt. iii. 16]; and we are not told whether any words were used at the time of the immersion¹. Of this rite our Lord Himself was pleased to partake, and by doing so consecrated the element of water to its future and higher use. A Baptismal rite was also used in the ministrations of our Lord, but not by Himself [John iii. 26; iv. 2]; and from the manner in which this was spoken of by the disciples of St. John the Baptist, it would appear that there was no outward distinction between this rite and that which he had used. In both cases an ancient custom of the Jews² appears to have been

¹ "John," says the Venerable Bede, "baptized with the baptism of repentance to confession of sins and amendment of life; and he preached the coming baptism of repentance in Christ for the remission of sins; in which latter baptism alone is remission of sins given to us, as the Apostles testify." [Homil. xviii.]

² See Lightfoot on Matt. iii.

adopted, signifying by a ceremony of ablution the cleansing away of an old life for the purpose of beginning a new one, as a proselyte to a new and a stricter faith. In the case of Jewish baptisms the change signified was from heathenism to Judaism; in that by St. John and our Lord from a sinful life as Jews to a good life as the disciples of the Baptist or of Christ. This significant use of water as the outward sign of admission to a new spiritual condition ought doubtless to be regarded as a preparation, by the Providence of Almighty God, for the sacrament which was to be instituted by our Lord.

There were also certain verbal and typical preparations made for that institution by our Blessed Lord Himself. At the outset of His ministry occurred His interview with Nicodemus [John iii. 1—15], in which He spoke of a result of Baptism which had evidently never been supposed to accompany it hitherto. Men were to be *born* of water and the Spirit that they might enter into the kingdom of Heaven: and although Nicodemus must have been familiar with the Baptism of proselytes, the idea of new birth by the use of Baptism was evidently novel to him³. At the close of His ministry, our Lord washed the feet of His disciples, teaching them that the act, as performed by Him, was not only a sign of humility, but also a means of spiritual purification; a truth the full meaning of which was not then revealed to them, but would be at a later period, when its revelation was to be a part of the instructions given for their appointed work [John xiii. 4—10]. And in the midst of His ministry Jesus had taken little children in His arms and blessed them, that by His touch and word they might be admitted (even without other sacrament) to the kingdom of God, and that the Church might learn for ever to suffer little children to come to Him, and forbid them not. Lastly, when blood and water flowed from the side of the Lord, the connexion between His Death and the two Sacraments was unmistakably symbolized.

Thus, by the course of His Providence, our Lord had prepared the Jews, and the Apostles especially, for the institution of Christian Baptism. (1) They had become familiar with the use of water as an external sign of a spiritual change; (2) they had been instructed (by words the meaning of which was to be developed to them by the Holy Ghost) that the use of water was to be not a *sign only*, but also the *means* of spiritual cleansing and new birth into the kingdom of God; and (3) it had been shown them that even little children were capable of entering that kingdom. And, thus prepared by our Lord's words and acts, the Apostles received His last command and commission, "Go ye therefore, and teach [*μαθητεύσατε*, see margin of English Bible] all nations, baptizing them in the name of the Father, and of the Son, and of the Holy Ghost." Their work was, as it had been hitherto, to "make disciples;" as they had long been doing, they were to admit to discipleship by baptizing, i. e. by immersing

³ This seems beyond doubt, notwithstanding the alleged Jewish use of the expression "new birth" in connexion with the baptism of proselytes.

their converts in water : but the rite was now to be distinguished from all previous baptisms by being administered with the most solemn words that man can use, an invocation of the One God in three Persons¹. [Matt. xxvii. 19.]

The subsequent parts of the New Testament show that the Apostles carried out this command of our Lord in its most literal sense. When a multitude had been converted on the Day of Pentecost, and asked, "Men and brethren, What shall we do?" St. Peter's immediate answer was, "Repent, and be baptized every one of you" [Acts ii. 38]; and the same day there were added to the little flock which then made up Christ's mystical Body about three thousand souls. When the people at Samaria "believed Philip preaching the things concerning the kingdom of God, and the name of Jesus Christ, they were baptized, both men and women" [Acts viii. 12]. So it is recorded of the eunuch, Saul, the household of Cornelius, the household of Lydia, the Philippian gaoler "and all his," the household of Stephanas, and many others, that they were baptized according to our Lord's commands as soon as they had been converted to belief in Him: and the cases recorded furnish evidence sufficient to give us a moral certainty that the Apostles universally baptized, or caused to be baptized all, in every place, who desired to be added to the Church.

§ Administration of Baptism in the Primitive Church.

Of the manner in which the Sacrament of Baptism was administered in the Apostolic age we have no detailed record beyond the fact that it was ordinarily by immersion, and that the invocation of the Blessed Trinity accompanied the immersion. St. Paul twice speaks of being "buried in baptism" [Rom. vi. 4. Col. ii. 12], and St. Chrysostom uses the expression "a certain burial in water" [Hom. in Johan. xxv.] with an evident reference of the Apostle's words to the act of immersion in baptism. Shortly after the time of the Apostles, Tertullian describes the rites of Baptism in general terms as follows:—"To begin with Baptism, . . . we do in the Church testify, under the hand of a chief minister, that we renounce the Devil, his pomps, and his angels. Then are we thrice dipped," or, as in another place, "we dip not once but thrice, at the naming of each Person of the Blessed Trinity . . . pledging ourselves to something more than the Lord hath prescribed in the Gospel. . . . After this, having come out from the bath, we are anointed thoroughly with a blessed unction . . . next to this the hand is laid upon us, calling upon and inviting the Holy Spirit through the blessing . . . some undertaking the charge of us, we first taste a mixture of honey and milk, and from that day we abstain a whole week from our daily washing" [Tertull. de Coron. v. 3, adv. Prax. xxvi., de Bapt. vii. and viii.]. From St. Cyprian, in the following century, we learn that the water was "first cleansed and sanctified by the priest" (or Bishop), "that it may be able, by Baptism therein, to wash away the sins of the baptized:" and that interrogatories were used, "Dost thou believe in eternal life, and remission of sins through the holy Church?" [Cyp. Ep. xlix. 6; lxx. 1, 2.] In the latter half of the fourth century St. Cyril of Jerusalem gave his lectures on the Mysteries to the recently baptized; and the first three being on the rites before and after Baptism, we may gather in some detail what was the custom of the Church in that day. "First ye entered into the outer hall of the Baptistery, and there facing towards the West ye heard the command to stretch forth your hand; and as in the presence of Satan ye renounced him . . . with arm outstretched to say to him as though actually present,

¹ The Institution of the Sacrament of Baptism is not to be looked for in an exemplary action of our Lord, as in the case of the other Sacrament; for we are expressly told that our Lord did not baptize. [John iv. 2.] The view taken above is substantially that of the ancient handbook of the Clergy, the Pupilla Oculi, in which is the following passage:—"Baptismus Christi fuit institutus materialiter et inchoative; quando Christus tactu suæ mundissimæ carnis vim regenerativam aquis contulit. Præceptive; quando dixit Nichodemus, nisi quis renatus &c. Effective; quando Christus passus est in cruce. Usus fuit inchoatus; quando misit discipulos suos ad prædicandum et baptizandum. Promulgatus ad omnes; post passionem, Matthæi ult." [Pupil. Oculi iii. 24.]

'I renounce thee, Satan, and all thy works, and all thy pomp, and all thy service.' Then thou wert told to say, 'I believe in the Father, and in the Son, and in the Holy Ghost, and in one Baptism of repentance.' And these things were done in the outer chamber. As soon as ye entered into the inner chamber, ye put off your garment, and this was an image of putting off the old man with his deeds. Then when ye were unclothed, ye were anointed with exorcised oil from the very hairs of your head to your feet, and were made partakers of the good olive-tree, Jesus Christ. After these things, ye were led to the holy pool of Divine Baptism, as Christ was carried from the Cross to the Sepulchre, which is before our eyes². And each of you was asked whether ye believed in the name of the Father, and of the Son, and of the Holy Ghost, and ye made that saving confession, and descended three times into the water, and ascended again; here also covertly pointing by a figure to the three days' burial of Christ . . . And at the selfsame moment ye died and were born; and that water of salvation was at once your grave and your mother. After you had come up from the pool of the sacred streams the unction was given, the emblem of that wherewith Christ was anointed. This holy ointment . . . is symbolically applied to thy forehead and thy other senses; and while thy body is anointed with visible ointment, thy soul is sanctified by the Holy and Life-giving Spirit. And ye were first anointed on your forehead . . . then on your ears . . . then on your nostrils . . . then on your breast. When ye are counted worthy of this holy Chrism ye are called Christians, verifying also the name by your new birth" [Cyril, Catech. Lect. xix. xx. xxi.]. To these early customs of the Church it may be added that white garments were worn by the newly baptized for eight days or more after their Baptism³ [Ibid. iii. 16; xxii. 8], and that a new name was given, as Peter and Paul received new names on their conversion, whose names, with that of St. John, were "used by many among the faithful" [Euseb. vii. 25].

The earliest Baptismal Office that has been handed down to modern times is that contained in the Sacramentaries of Gelasius and St. Gregory; of which the following summary (taken from the Easter-Eve Service of the latter) will give a sufficient view⁴.

§ Administration of Baptism in the Sixth Century.

[1] The clergy and people being assembled in the church at the eighth hour [2 P.M.], the clergy went within the sacarium, having on the customary vestments; and two tapers being lighted, and held at each corner of the altar by two notaries or readers, another reader went up to the ambon, and read eight Lessons concerning the creation of man, the temptation of Abraham, and other appropriate subjects from Exodus, Isaiah, and Jonah,—after each of which was said a Collect founded on the preceding lesson; and before the last Collect was sung, "Like as the hart desireth the waterbrooks," &c.

[2] A procession was formed from the altar "ad fontes," the "school" or quire singing the "Litania septena⁵," the taper-bearers, and a minister carrying the ampulla of consecrated oil, going before the Bishop, who was supported by a Deacon on either side.

[3] The prayers for the Benediction of the font were said by the bishop, who, at a particular part of them, divided the water with his hand in the form of a cross; at a second, held the taper in the water; and, at a third, breathed on the water thrice, afterwards pouring in the chrism in the form of a cross, and spreading it with his hands⁶.

² This was said in Jerusalem.

³ See Notes to the 1st Sunday after Easter, p. 107.

⁴ The admission as *Catechumens* of those who were afterwards to be baptized took place as a separate ceremony some time previously. It has not been thought necessary to give any account of this service above, as, although incorporated with that for Baptism in later times and in our own office, it was really a separate rite.

⁵ See some notice of the Litania Septena, and the analogous Litania Septiformis, at p. 47. Menard [Notes 91] seems to consider that these were identical, but the Litania Septena was probably sung by those only who were in Holy or in Minor Orders.

⁶ St. Augustine notices the custom of signing the water with the cross in his 118th Homily on St. John, and in his 191st Sermon *de Tempore*.

[4] When the benediction of the water was ended, the "infants" were baptized, first the boys and then the girls; the Interrogatories being first made of those who brought them in the following form:—"Quis vocaris? *Resp. Ill. Item interrogat Sacerdos: Credis in Deum Patrem Omnipotentem, Creatorem cœli et terræ? Resp. Credo. Interrogat: Et in Jesum Christum Filium ejus unicum Dominum nostrum, natum et passum? Resp. Credo. Interrogat: Credis et in Spiritum Sanctum, Sanctam Ecclesiam Catholicam, Sanctorum Communionem, remissionem peccatorum, carnis resurrectionem, vitam æternam? Resp. Credo. Interrogat: Vis baptizari? Resp. Volo: Et dicit. Et ego baptizo te in nomine Patris, et Filii, et Spiritus Sancti."* Then when the newly baptized was taken from the font he was given to one of the priests, who made the sign of the cross upon the crown of his head with the chrism, saying, "Almighty God, the Father of our Lord Jesus Christ, Who hath regenerated thee by water and the Holy Ghost, and hath also given to thee remission of all thy sins, anoint thee with the chrism of salvation unto eternal life. Amen!" After this the baptized infants and adults were confirmed by the Bishop, the names being given by him during the act of Confirmation; and the service was ended with the Holy Communion.

The mediæval Offices for Baptism were founded on this ancient and perhaps primitive one; but several ceremonies were added, and the offices were much increased in length. They were divided into three distinct parts, the first of which was entitled, "Ordo ad faciendum Catechumenum;" the second, "Benedictio Fontis;" and the third, "Ritus Baptizandi." Those of the Salisbury Use are partly represented in the right-hand column and in the foot-notes of the following pages, but it may be useful to give a summary, showing the exact order of their several parts, and the ceremonies with which the sacrament was administered.

§ *The Administration of Baptism in the Mediæval Church of England.*

α] Admission of a Catechumen.

[1] The child being held without the doors of the church, the priest made the sign of the Cross upon its forehead and breast, saying, "I place the sign of our Lord and Saviour Jesus Christ on thy forehead . . . and on thy breast." Then he placed his hand upon the head of the child, while he offered a prayer, beseeching God to open to it the door of His mercy, and grant it the grace of Baptism.

[2] Salt, over which an exorcism had been said, was placed in the mouth of the child with the words, "N. Receive the salt of wisdom, that God may be gracious to thee unto life everlasting. Amen." This was followed by a prayer that God would send His holy angel to take care of His servant N., and bring him to the grace of Baptism.

[3] An exorcism and adjuration of Satan to forsake the child was then said; followed by another signing with the cross, and a prayer that the child might be turned from darkness to light, and made fit to receive Baptism.

[4] The Gospel was then read.

[5] The ears and nostrils of the child were touched with saliva.

[6] The Lord's Prayer, Hail Mary, and Creed, were said by the priest, sponsors, and congregation.

[7] The child was again signed with the cross, the words "Trado tibi signaculum," &c. being said; and afterwards the priest, taking him by the right hand, led him within the church, saying, "Enter thou into the house of God: that thou mayest have eternal life, and live for ever and ever. Amen."

β] Benediction of the Font.

[1] A Litany was said, similar to that in ordinary use, as far as the end of the Invocations.

¹ This prayer is found at an earlier date, in the fourth century. See St. Ambrose de Myst., iii. 7.

[2] The Benediction followed, with similar prayers and ceremonies to those of the Gregorian Sacramentary.

γ] The Baptism.

[1] The child being brought to the font, the priest placed his right hand upon him, asked his name, and made the interrogatories of abrenunciation.

[2] The priest anointed the child with chrism, in the form of a cross, on the breast and between the shoulders.

[3] Then followed the profession of faith, and the "Quid petis?" and "Vis baptizari?"

[4] The act of Baptism followed, with trine immersion, as shown further on in the service itself.

[5] This was followed by the signing with the cross, as in the Gregorian Office.

[6] The chrisom, or white vestment, was put upon the child with the words, "N. Receive a white, holy, and spotless vesture, which thou shalt bear before the judgment-seat of our Lord Jesus Christ, that thou mayest have eternal life, and live for ever and ever. Amen."

• [7] A lighted taper was placed in the hand of the child, with the words, "N. Receive a burning light that cannot be taken out of thy hand: guard thy baptism, keep the commandments, that when the Lord shall come to the wedding, thou mayest be able to meet Him in company with His saints in the heavenly bride-chamber; that thou mayest have eternal life, and live for ever and ever. Amen."

The changes made in the above Office in 1549 were not very great, but considerable alterations were made in 1552, and all the ancient ceremonies have now disappeared from the English Service except the signing with the cross. It is scarcely necessary to add that these ceremonies are no part of the essentials of Holy Baptism, and that so much popular superstition had grown up around them as to make their abolition appear desirable to those who reconstructed the Offices of the Church of England². The successive alterations which were made will be found in the notes to the various parts of the services for the Public and Private Baptism of Infants. The Office for the Baptism of Adults was an addition of 1661.

§ *The Essentials of Holy Baptism.*

The words of our Lord to the Apostles seem so clear as to place beyond a doubt what is essential to a true Christian Baptism: "Go ye therefore, and teach all nations, baptizing them in the name of the Father, and of the Son, and of the Holy Ghost" [Matt. xxviii. 19]. Yet questions have arisen, from very early ages, as to the *matter* and *form* with which the Sacrament is to be administered, and also as to the *person* by whom it is to be administered. Tertullian, in the opening of his treatise on Baptism, speaks of a sect which denied the necessity of water in Baptism [Tertull. de Bapt. i.]; and St. Augustine refers to the rejection of water because created by the evil one, and therefore in itself evil, as one of the heresies of the Manichæans. [Aug. de Hæres. xlvi.] In the twelfth century, the Cathari, or Puritans,

² At the end of the Office a Gospel was inserted [Mark ix. 17-29], which was to be used, if desired, for the prevention of the falling sickness,—"quia secundum doctores maxime valet pro morbo caduco."

There is, however, a touching anecdote on record which seems to indicate that, like some other changes, these were *forced* upon the Convocation by considerations of expediency rather than principle. During the reign of Queen Mary, a Mrs. Hickman, whose husband had fled out of the country, was sent down to a gentleman's house in Oxfordshire for her approaching confinement, as she was not able to bear the voyage to Germany. But when her child was born she was in a dilemma about the baptism, not liking to have it baptized by a 'Romish priest' according to the ritual then of late restored. So she contrived to send a message to the Bishops then in prison at Oxford to know what she should do, and their answer was, that she might safely employ the priest, for that 'the Service for Holy Baptism was of all the Services, that in which the Church of Rome had least departed from the truth of the Gospel and the primitive practice.' This anecdote is given in Massingberd's Lectures on the Prayer Book, p. 123, from the leaves of a copy of Beza's New Testament, belonging to a descendant of the family. The testimony is valuable, as two of the imprisoned Bishops, Cranmer and Ridley, were connected with every step taken in the Reformation of the ancient Offices.

denied the necessity of the Sacrament altogether, but adopted a ceremony which they called baptism with fire, as a substitute for that with water. The Waldenses also regarded water as unnecessary to a spiritual baptism; and the Flagellants of Germany, Poland, Hungary, and France, held that the only true baptism was one in blood, effected by scourging the body. With respect to the form of words in which the person is to be baptized, it is sufficiently evident that all who have rejected the doctrine of the Blessed Trinity must necessarily have modified and adapted to their own principles the words used by the Church, if they continued to administer a rite in imitation of Christian Baptism. The Arian form is given by St. Jerome [cont. Lucif.], and the Eunomian by Epiphanius [Hæres. lxxvi.]; but both are too irreverent towards the second and third Persons of the Holy Trinity to be set down here.

Such practices gave rise to strict definitions on the part of the Church, which are represented by the questions in our Office for Private Baptism of Children: "Because some things essential to this Sacrament may happen to be omitted through fear or haste, in such times of extremity; therefore I demand further of you,

"With what matter was this child baptized?"

"With what words was this child baptized?"

In the first rubric of the Office for Public Baptism, also, the font is directed to be filled with "pure water;" and in the Catechism "the outward visible sign or form of Baptism" is clearly stated to be "Water; wherein the person is baptized *In the Name of the Father, and of the Son, and of the Holy Ghost.*" Such distinct language being used by the Church of England, it may also be well to add that which was used by the Council of Trent: "If any one shall say, that true and natural water is not of necessity for Baptism, and, on that account, shall wrest to some sort of metaphor those words of our Lord Jesus Christ, 'Except a man be born of water and of the Holy Ghost,' let him be anathema." [Sess. vii. Can. ii. de Bapt.] It may also be added that cases of necessity have occasionally arisen, in which pure water was not at hand for the purpose of baptism, when wine, or even sand, has been used as the element or material of Baptism: but sound theologians have always ruled that this ceremony could not be a true and valid administration of the Sacrament. Such cases of emergency may arise, even in the present day, among missionaries; and it is therefore well to point out this general consent of the Church to take our Lord's words in their literal sense, "baptizing them with water," and to follow literally the practice of His Apostles as recorded several times in the New Testament. [Acts viii. 36; x. 46. 1 Pet. iii. 20. Cf. also Ezek. xxxvi. 25.]

The form of words used by the Church of England is that which is used by the whole Western Church, and that which has been so used from time immemorial. In the Eastern Church a similar form is used, but in the third person, and with a passive verb: "The servant of God, *N.*, is baptized in the Name of the Father, and of the Son, and of the Holy Ghost." The essential part of the form is the distinct mention of each Person of the Blessed Trinity with reference to the act of Baptism; and both East and West therefore agree in naming (1) the person, (2) the act of Baptism, and (3) the three several Persons of the Holy Trinity. The most ancient records of the Church point to the Western form, as shown in the citation made above from the Sacramentary of St. Gregory, and this form differs from the Eastern in also naming the person baptizing, "*I baptize thee:*" but it may be considered that this is included in the Eastern form, since the statement that the person "is baptized" comprehends elliptically the words "by me, who am now performing the act, and speaking the words." Such an explanation of the Eastern form cannot, however, justify any, the slightest, departure from the other in the Church of England¹.

The original mode of administering Holy Baptism was un-

¹ It is supposed that the Eastern form was adopted as a standing refutation of the error that the virtue of Baptism was derived from the person ministering it: an error apparently referred to in the words of the Apostle, "Every one of you saith, I am of Paul; and I of Apollos; and I of Cephas; and I of Christ." [1 Cor. i. 12.]

doubtedly by the descent of the person to be baptized into a stream or pool of water. It is probable that the person baptizing also stood in the water [Acts viii. 38], and poured some of it with his hand upon the head of the other, as the latter bowed himself three times (at the naming of each Person of the Trinity by the baptizer) into the stream. St. Paul gave a beautiful symbolical meaning to this practice of immersion, when he said, "We are buried with Him by baptism into death: that like as Christ was raised up from the dead by the glory of the Father, even so we also should walk in newness of life" [Rom. vi. 4]. When fonts were made in churches, they were made with a descent of seven steps, symbolizing the sevenfold gift bestowed by the Holy Ghost [Isidore de Ecc. Off. ii. 24]; and this implies a considerable depth of water, reaching to about the waist of an ordinary-sized man. The practice of *trine* immersion also appears to be of primitive origin. It is mentioned by Tertullian, and other early Fathers, in passages already quoted; and also by St. Ambrose, in his Treatise on the Sacraments; St. Basil, in his work on the Holy Spirit; and St. Leo, in his fourth Epistle: and all give substantially the same account of the practice with that given by St. Ambrose: "Thou wast asked, Dost thou believe in God the Father Almighty? Thou didst answer, I believe, and didst dip into the water, that is, thou wast buried. Again wast thou asked: Dost thou believe in Jesus Christ our Lord, and in His Cross? Thou didst answer, I believe, and didst dip into the water: therefore also thou wast buried with Christ: for whosoever is buried with Christ, shall rise again with Christ. A third time wast thou asked: Dost thou believe in the Holy Ghost? Thou didst reply, I believe; and a third time didst thou dip into the water." The Apostolical Constitutions of the fifth century even forbade the practice of single immersion, decreeing in their fiftieth Canon: "If any bishop or priest does not perform the one initiation, with three immersions, but with giving one immersion only into the death of our Lord, let him be deposed. For the Lord said not, Baptize into My death; but, Go—baptizing them in the Name of the Father, and of the Son, and of the Holy Ghost." Yet there seems to have been an early necessity for guarding against error in the use of this trine immersion, and St. Gregory of Nyssa writes: "We immerse to the Father, that we may be sanctified: we immerse to the Son also to this same end: we immerse also to the Holy Ghost, that we may be that which He is and is called. There is no difference in the sanctification." The practice of immersion, whether trine or single, was not, however, regarded as an essential feature of Baptism. The Philippian gaoler "was baptized, he and all his, straightway," in prison, and in the middle of the night; and immersion in such a case seems extremely improbable. It seems almost equally unlikely in the case of Cornelius and his household. In days of persecution, when Christian rites could only be administered in secret, immersion could not have been universal: and there is abundant evidence that "clinic baptism,"—that is, the baptism of those who were on their death-beds,—was very common in those primitive days. Respecting the usage in the latter case, St. Cyprian wrote to Magnus [A.D. 255] in the following words: "You have inquired also, dearest son, what I think of those who in sickness and debility obtain the grace of God, whether they are to be accounted legitimate Christians, in that they are sprinkled, not washed, with the saving water. . . . I, as far as my poor ability conceiveth, account that the Divine blessings can in no respect be mutilated and weakened, nor any less gift be imparted, where what is drawn from the Divine bounty is accepted with the full and entire faith both of the giver and the receiver. . . . Nor should it disturb any one that the sick seem only to be sprinkled or afused with water, when they attain the grace of the Lord, since Holy Scripture speaks by the Prophet Ezekiel, and says, 'Then will I sprinkle clean water upon you, and ye shall be cleansed from all your filthiness, and from all your idols will I cleanse you; a new heart will I give you, and a new spirit will I put within you.' He then goes on to refer also to Numbers xix. 7, 19, 20; viii. 5—7; xix. 9; and adds, "Whence it is apparent that the sprinkling also of water has like force with the saving washing, and that when this is

done in the Church," not, i. e., by heretics, "where the faith both of the giver and receiver is entire, all holds good, and is consummated and perfected by the power of the Lord and the truth of faith." [Cyp., Ep. lxi. 11, 12.] The principle thus so plainly set forth by St. Cyprian has ever since been generally accepted by the Church, and ablution, or the *actual touch of water during the invocation of the Blessed Trinity*, has always been accounted the essential feature in the administration of Holy Baptism. Whether that ablution is effected by the more complete method of immersion, or by the less perfect one of affusion, the result is the same: care being always taken that the *actual contact* of the water with the person is really effected. And thus the rubric of the English Office leaves it discretionary whether the infants or adults to be baptized shall be dipped in the water, or have water *poured upon them*; security being provided for the actual contact of the water by the exclusion of mere *sprinkling*, which is not recognized at all in the Church of England, and can never be considered a safe method of applying the water, or a reverent way of obeying the command of our Blessed Lord, however much it may, as a *minimum* of obedience, fulfil the required conditions.

§ The Minister of Baptism.

Having said so much about the matter and form of Holy Baptism, it remains to be considered who is the proper minister of the sacrament.

There can be no doubt that in the first instance our Blessed Lord gave to His Apostles a commission to "baptize all nations," and that such a commission was to be handed on to those who were to take up their work after their deaths, those whom they ordained for that purpose according to the words of their Master, "As My Father hath sent Me, so send I you." Very early in the history of the Apostolic Church also, we find a deacon, Philip, baptizing at Samaria, and the Apostles, St. Peter and St. John, ratifying his act by confirming those whom he had baptized. From this it may be concluded that as the Bishops are the one principal channel through which ministerial authority is conveyed from our Lord, the Fountain of all such authority, to others, so they undoubtedly commissioned inferior ministers to baptize in the very beginning of the Christian Church.

But the question soon arose whether the nature of Holy Baptism was not such as to make a Bishop, Priest, or Deacon, absolutely essential to its right administration; and upon this subject three theories have been held. (1) The first and strictest of these was that maintained by St. Cyprian, who esteemed that Baptism only to be true and effective which is administered by those who have been ordained by orthodox Bishops, and are in communion with the Church. (2) The second theory was much more generally held in the early Church, viz., that even schismatics and heretics could give true Baptism, provided they were in holy orders. (3) A third, and this was that held by St. Augustine, made the essence of the Sacrament to consist in the application of the water with the proper words of Invocation, by whomsoever this was done. The Council of Arles [A.D. 314] decided by their eighth Canon against the first theory, and in favour of the second; a decision practically confirmed by the nineteenth Canon of the Council of Nicæa, which directed the re-baptism of those only who had been baptized by the followers of Paul of Samosata, and so not in the Name of the Blessed Trinity. No further decision on the subject was ever given by a General Council, and thus the question still remained open whether those who were not in Holy Orders could, by the proper use of water and the proper Invocation, administer a true Baptism. In ancient times this question was not one of very extensive bearing, as none but the Clergy ever baptized, except in cases where there was danger of death, and no clergyman could be found. But in modern times it has become a matter of primary importance, as a considerable portion of the people of England, and the majority of those born in Protestant countries, are baptized by persons who have never been ordained by Bishops, and who are not therefore either Priests or Deacons

in the sense of the Church of England, of Churches of the Roman communion, or of the Eastern Church.

The validity of such Lay Baptism was maintained by Tertullian [de Bapt. xvii.], who however adds that a woman is as much forbidden to baptize as to teach in the Church. It was allowed by the Patriarch of Alexandria in the case of some boys baptized by Athanasius when he himself was a boy. [Rufin. i. 14.] St. Augustine maintained it to be valid, not only in cases of necessity, but under other circumstances also. [Aug. de Bapt. vii. 102, cont. Parmen. ii. 13.] St. Jerome also allowed it in case of necessity; and the Council of Illiberis or Elvira [A.D. 300] decided in its thirty-eighth Canon that no re-baptism was necessary for those who had been baptized in an emergency by laymen, but only that the persons so baptized should be brought to the Bishop for Confirmation, if they should survive. Without citing any further authorities, it may be sufficient to give the emphatic words of Hooker, "Yea, 'Baptism by any man in case of necessity,' was the voice of the whole world heretofore." [Ecc. Polit. V. lxi. 3.] He also affirms in his subsequent argument, that even Baptism by women in case of extreme necessity was valid, and not to be reiterated.

The principle thus laid down has been definitely stated from time to time by English synods from a very early age; and the "Pupilla Oculi," which was a standard book of instructions for the Clergy in the mediæval period, has some exhaustive statements on the subject [ii. 2], which plainly show that it was the practice to recognize Baptism as valid, by whomsoever administered, if given with the proper matter and form of words; which practice undoubtedly continued up to the time of the Reformation. This is, at the same time, shown most clearly and authoritatively by the rubric placed at the end of the Ritus Baptizandi in the Salisbury Manual, which is as follows:—"*¶ Notandum est quod quilibet sacerdos parochialis debet parochianis suis formam baptizandi in aqua pura, naturali, et recenti, et non in alio liquore, frequenter in diebus dominicis exponere, ut si necessitas emergat sciant parvulos in forma ecclesie baptizare, proferendo formam verborum baptismi in lingua materna, distincte et aperte et solum unica voce, nullo modo iterando verba illa rite semel prolata, vel similia super eundem: sed sine aliqua additione, subtractione, interruptione, verbi pro verbo positione, mutatione, corruptione, seu transpositione sic dicendo: I christene the N. in the name of the Fadir, and of the Sone, and of the Holy Gost. Amen. Vel in lingua latina, sic: Ego baptizo te, N. in nomine Patris, et Filii, et Spiritus Sancti. Amen. Aquam super parvulum spargendo, vel in aquam mergendo ter vel saltem semel¹."*

The substantial part of the above rubric was retained in the Book of Common Prayer in the following words:—

"*¶ The Pastors and Curates shall oft admonish the people that they defer not . . . And also they shall warn them that without great cause and necessity they baptize not children at home in their houses. And when great need shall compel them so to do, that then they minister it on this fashion. ¶ First, let them that be present call upon God for his grace, and say the Lord's Prayer, if the time will suffer. And then one of them shall name the child, and dip him in the water, or pour water upon him, saying these words: ¶ N. I baptize thee in the name*

¹ Another rubric added this caution: "*¶ Non licet laico vel mulieri aliquem baptizare, nisi in articulo necessitatis. Si vero vir et mulier adessent ubi immineret necessitatis articulus baptizandi puerum, et non esset alius minister ad hoc magis idoneus præsens, vir baptizet et non mulier, nisi forte mulier bene sciret verba sacramentalia et non vir, vel aliud impedimentum subesset.*" But midwives were constantly licensed by the Bishops to baptize in case of necessity [Burn's Ecc. Law, Art. Midwives] down to quite recent times. It may also be added that surgeons frequently baptize children in danger of death at the present day. [Blunt's Directorium Pastorale, p. 156.] In 1584 the Puritans presented a memorial to Archbishop Whitgift, praying, amongst other things, "that all baptizing by midwives and women may from henceforth be inhibited and declared void." The Archbishop replied that the Baptism of even women is lawful and good, "so that the institution of Christ touching the word and element is duly used;" and he adds that no learned man ever doubted that such was the case, though some of late by their singularity in some points of religion had given the adversary greater advantage than any thing else could do.

of the Father, and of the Son, and of the Holy Ghost. Amen. *And let them not doubt, but that the child so baptized is lawfully and sufficiently baptized . . .*" After the Hampton Court Conference, in 1603, the above rubric was altered to meet the prejudices of the Puritans, the words "*lawful minister*" taking the place of "*one of them*." In 1661, this was further altered to "*the Minister of the Parish*," and at Bishop Cosin's suggestion was added "*(or in his absence, any other lawful Minister that can be procured)*:" and these successive alterations have been supposed to narrow the theory of the Church of England respecting Baptism, and to restrict its valid administration to Bishops, Priests, and Deacons. But, although these additions and alterations were probably made with the object of checking Lay Baptisms, it cannot be said that they contain any decision against their validity; nor, indeed, can it be supposed, for a moment, that the prudent men who superintended the various revisions of the Prayer Book would have reversed, merely by a rubric, the long-established tenet of the Church of England that Lay Baptisms are in some cases necessary, and are not to be repeated. Moreover, in the questions to be asked by the Clergyman of those who bring a privately-baptized child to the Church to be received, it is expressly stated that the "things essential to this Sacrament" are the "matter" and the "words," no notice being given that the person who performed the ceremony was one of these "things essential" more than those who were present. Lastly, although there were supposed to be about 300,000 persons in England who had been baptized by laymen, at the time when the Clergy were restored to their duties in 1661, no public provision was made by the Church for rebaptizing them, nor does it appear that any doubt whatever was thrown upon the validity of their baptism by those who revised our offices.¹

Lay Baptism being thus allowed to be valid in case of necessity, it is yet clear that its validity depends upon the manner of its administration, not upon the reality of the necessity; and hence even if there is no such necessity, it must still be accounted valid, provided the proper matter and form are used. And Baptism by those who have not received Holy Orders (however they may lay claim to ministerial authority) being of this latter class, it must be granted that the question of its validity resolves itself into a question of the actual administration by water and the proper words of the sacrament. No doubt there is much uncertainty respecting this; for many Dissenters attaching little importance to Baptism, it is reasonably to be supposed that they would be sometimes indifferent about exactness in administering it. For cases of doubt the hypothetical form, "If thou art not already baptized," &c., is provided; and by its use an unconscious iteration of Baptism is avoided, while at the same time the certainty of its administration is secured.

It is hardly necessary to add that Lay Baptism should be resorted to only in great extremity; and that when the Sacrament is administered by one who is not ordained without such necessity, the person baptizing is guilty of a great sin, even though his act may bring a blessing to the person baptized. His act cannot be undone, but it ought not to have been done.

§ The Effect of Holy Baptism.

It remains now to speak of the spiritual benefits which result from Holy Baptism to those who duly receive it according to the ordinance of our Lord and Saviour Jesus Christ. They are spoken of in the Offices as "a washing and sanctifying with the

¹ It must not be forgotten that "*minister*" in the Book of Common Prayer means "*executor officii*," and that if it was used here in that sense, the addition of "*lawful*" does not by any means of necessity restrict it to a clergyman. The "*alius minister ad hoc magis idoneus*" of the rubric given in the preceding note, shows that the word "*minister*" was used even of a lay person in the case of the ministration of Baptism, long before the Reformation.

² The judgment of Lord Brougham in *Escott v. Mastin* goes very fully into the question of Lay Baptism, and decides in favour of the Catholic principle.

Holy Ghost, a deliverance from the wrath of God, a receiving into the ark of Christ's Church, a remission of sins by spiritual regeneration, an embracing with the arms of God's mercy, a gift of the blessing of eternal life, a participation of God's everlasting kingdom, a bestowal of the Holy Spirit, a being born again and made heir of everlasting salvation, a release from sins, a gift of the Kingdom of Heaven and everlasting life, a burial of the old Adam, and raising up of the new man, an enduing with heavenly virtues, a mystical washing away of sin, a regeneration and grafting into the body of Christ's Church, a death unto sin and a living unto righteousness, a putting on of Christ." In the Catechism the effect of Baptism is first stated in the familiar words in which every child replies, that "therein I was made a member of Christ, the child of God, and an inheritor of the kingdom of heaven;" and, secondly, in the definition of the inward and spiritual grace of the Sacrament, where it is described as "a death unto sin, and a new birth unto righteousness: for being by nature born in sin, and the children of wrath, we are hereby made the children of grace."

These blessings and benefits of Holy Baptism, thus set forth with such an overflowing fullness of language, are all comprehensively included in the Scriptural term "Regeneration;" the first use of which recorded in the New Testament is by our Blessed Lord when He said to Nicodemus, "Except a man be born again, Except a man be born of water and of the Spirit, he cannot see, he cannot enter into, the Kingdom of God." [John iii. 3. 5.] This language of our Lord is also that of His Apostles, as of St. Paul: "According to His mercy He saved us by the washing of regeneration, and renewing of the Holy Ghost, which He shed on us abundantly through Jesus Christ our Saviour; that being justified by His grace, we should be made heirs according to the hope of eternal life" [Titus iii. 5-7]: and of St. Peter, "Being born again, not of corruptible seed, but of incorruptible, by the word of God, which liveth and abideth for ever" [1 Pet. i. 23]. The mode by which God effects this regeneration is a mystery. "We know it," says Dr. Pusey, "in its author, God; in its instrument, Baptism; in its end, salvation, union with Christ, sonship to God, resurrection from the dead, and the life of the world to come." We only know it not, where it does not concern us to know it, in the mode of its operation.³ But though we do not know the manner in which God effects regeneration by the rite of Baptism, we are able to follow up the language in which the Church has ever been accustomed to speak of Holy Baptism, and to trace out its efficacious operation under the two heads indicated by St. Cyril's words, "at the self-same moment, ye died and were born" [Catech. Lect. xx. 4]; and by our English Catechism in the expression, "a death unto sin, and a new birth unto righteousness."

I. That which is comprehended under the first of these heads, "a death unto sin," is the breaking off from that chain of spiritual relationship between the baptized and Adam, by which they are, first, inheritors of a nature prone to evil rather than good; and, secondly, inheritors of the penalty due to sin.

(1) The inheritance of a fallen nature is not merely a historical circumstance, but a practical power exercising its influence upon those whose nature it is. The moral habitat of this fallen nature is among the lowest regions of moral intuition, or conscience, and of moral power. Good is naturally alien to it; evil is naturally its choice. It is, normally, incapable of spiritual perception, for "the natural man receiveth not the things of the Spirit of God, for they are foolishness unto him; neither can he know them, because they are spiritually discerned" [1 Cor. ii. 14]; and hence belief in miracles or sacraments is scarcely possible for those who are wilfully rejecting Baptism, and must always be difficult to the unbaptized, even when their condition arises from no fault of their own. But these characteristics of a fallen nature are removed by Holy Baptism. The nature is new-born; and with new birth come new faculties, such as a higher kind of conscience, faith, and moral strength. It has broken

³ Scriptural Views of Holy Baptism, p. 23.

off its bondage to the Fall, has become dead to the strongest and primary influences of it; and receives a tendency to rise towards good and the Author of good rather than to sink towards evil and the Evil One.

(2) There is also conveyed in Baptism a "death unto sin" in respect to the penalty which is its due,—the wrath of God, and the punishment which is an inevitable consequence of that wrath. This is the "remission of sins" which is connected with the "One Baptism" in the Nicene Creed. It is solemnly named to God in the ancient prayer before Confirmation which was said immediately after Baptism in the Primitive Church, and which is still retained in our English Confirmation Service:—"Almighty and ever-living God, who hast vouchsafed to regenerate these Thy servants by water and the Holy Ghost, and hast given unto them forgiveness of all their sins . . ." This remission extends to all actual sin in adults who come with penitence to Holy Baptism, as well as to original sin in all; and is so complete that, although an "infection of original sin" remains even in the regenerate, yet an entirely new life is begun in the favour of God, Who no longer regards the sin of the unregenerate condition in which the baptized person previously was, nor visits him with the punishment which must otherwise have fallen upon him. Hooker speaks of this as "that act of grace which is dispensed to persons at their baptism, or at their entrance into the Church, when they openly professing their faith, and undertaking their Christian duty, God most solemnly and formally doth absolve them from all guilt, and accepteth them to a state of favour with Him." [Serm. on Justification.] In the same manner Bishop Jewell declares in his Defence of the Apology of the Church of England: "We confess, and have evermore taught, that in the Sacrament of Baptism, by the death and blood of Christ, is given remission of all manner of sin, and that not in half, in part, or by way of imagination, or by fancy, but whole, full, and perfect, of all together; so that now, as St. Paul saith, 'there is no condemnation to them that be in Christ Jesus.'" [Def. of Apol. II. xi. 3.] As when Naaman washed in Jordan "his flesh came again like unto the flesh of a little child," so the waters of Baptism effect that cleansing of our fallen nature from the leprosy of sin of which our Lord spoke when He said, "Except ye be converted and become as little children, ye shall not enter into the kingdom of Heaven" [Matt. xviii. 3].

II. A new birth unto righteousness includes, first, Adoption by God, and, secondly, Union with our Lord Jesus Christ.

(1) In adopting as His children those who were previously alienated from Him, our merciful Father establishes a new relation between Himself and those whom He adopts, giving them a claim to paternal love and the privileges of sonship. This adoption is often called Justification in the New Testament, as

where St. Paul says, "According to His mercy He saved us by the washing of regeneration, and renewing of the Holy Ghost, which He shed on us abundantly through Jesus Christ our Saviour; that being justified by His grace, we should be made heirs according to the hope of eternal life." [Tit. iii. 5—7.] God is the *efficient* cause of this justification; our Lord Jesus Christ is the *meritorious* cause of it; and Holy Baptism is the *instrumental* cause of it. And when God, for the sake of Christ's merits, and by the instrument of Baptism, has thus made them "heirs of eternal life," His children are entitled (through His free gift, and not by their deservings) to assisting grace by which they may be enabled to do His will while they are in a state of probation; and to that everlasting life which He has promised to those who are faithful and steadfast, when their state of probation is ended.

(2) A mystical union is effected in Baptism, by some unintelligible and supernatural operation, between the baptized and our Lord Jesus Christ. They are united to the Body and Soul of His human nature, and since that is inseparable from the Godhead, they are also through it united to His Divine Nature. By means of the union thus effected with the Person of their Mediator, they receive through Him the Divine gift of grace to which the Father's mercy entitles them. That grace is an active principle working in them to mould them to the pattern of Him of Whom they have become members. By it they are enabled both to know and to do the will of God; and a moral perfection of which the *natural life* is not capable becomes easy in the *Christian life* through this co-operating power of Christ. Through the same grace is derived an illumination of the mind by which it is enabled to grasp the knowledge of Divine truth, and in faith to receive those mysteries which are at present beyond the power of even an illuminated Christian understanding; they who wash at the Divine command, "come again seeing." And, lastly, this union with Christ through Baptism plants the germ of eternal life in the nature of the baptized person, restoring an immortality that was lost by the Fall; and reopening the Vision of God to the eyes of man.

Thus, then, the effect of Holy Baptism may be once more summed up in the words of the Apostle, "Know ye not that so many of us as were baptized into Jesus Christ were baptized into His death? Therefore we are buried with Him by baptism into death; that like as Christ was raised up from the dead by the glory of the Father, even so we also should walk in newness of life. For if we have been planted together in the likeness of His death, we shall be also in the likeness of His resurrection . . . Likewise reckon ye also yourselves to be dead indeed unto sin, but alive unto God through Jesus Christ our Lord." [Rom. vi. 4—11.]

THE MINISTRATION OF
PUBLIC BAPTISM OF
INFANTS,

TO BE USED IN THE CHURCH.

¶ *The people are to be admonished, that it is most convenient that Baptism should not be administered but upon Sundays, and other Holy-days, when the most number of people come together; as well for that the Congregation there present may testify the receiving of them that be newly baptized into the number of Christ's Church; as also because in the Baptism of Infants every Man present may be put in remembrance of his own profession made to God in his Baptism. For*

BAPTISMUS PUERORUM.

[ORDO AD FACIENDUM CATECHUMENUM.

BENEDICTIO FONTIS.

RITUS BAPTIZANDI.]

Salisbury Use.

. the Pastors shall warn the people that they bring their children to be baptized at those hours, when, after the custom, the people resort together, to hear the Lord's word.

Daye's transl. of
Herman's Con-
sult. A. D. 1547.

THE TITLE AND INTRODUCTORY RUBRICS.

Publick Baptism to be used in the Church] The administration of Holy Baptism has always been, from the very beginning, a public ceremony, except in cases of urgency: not because publicity is in any way essential to the efficacy of the Sacrament, but that it might be given in the face of the Church. One of the Rubrics at the end of the ancient office for Baptism in the Church of England is as follows:—“¶ *Non licet aliquem baptizare in aula, camera, vel aliquo loco privato, sed duntaxat in ecclesiis in quibus sunt fontes ad hoc specialiter ordinati, nisi fuerit filius regis vel principis, aut talis necessitas emergerit propter quam ad ecclesiam accessus absque periculo haberi non potest.*” In 1552 the word “Public” was expunged from the title of this Office, but it was restored in 1661.

Infants] Baptism has been given to Infants from the time of its first institution. No direct record of the custom of the Apostles is contained in Holy Scripture, but the fact that they baptized whole households is indirect evidence that the Sacrament was not denied to children. Our Lord's act and words in blessing little children, and requiring the disciples to suffer them to come to Him and not to forbid them, is the strongest testimony that could be given short of the connexion of this command with the actual rite of Baptism, of His will on the subject. About A. D. 148, Justin Martyr writes, that there were in his time “many of both sexes, some sixty and some seventy years old, who had been made disciples to Christ from their infancy;” and Irenæus, not long after, speaks distinctly of “infants and little children, and boys and young men and old men,” all being alike new born to God by Holy Baptism [adv. Hæres. ii. 22, al. 38]. St. Cyprian, writing to Fidus [Ep. lxiiv.], says, “We all judge that the mercy and grace of God is to be denied to none born of man,” and the Epistle is written to contradict the opinion of Fidus, that infants ought not to be baptized until they are eight days old. St. Cyprian declaring that no infant can be too young to be baptized. St. Augustine speaks of “infants baptized in Christ,” and says, “In babes born and not yet baptized, let Adam be acknowledged; in babes born and baptized, and thereby born again, let Christ be

acknowledged.” “Infants too,” he writes in another place, “are carried to the Church; for if they cannot run thither on their feet, they run with the feet of others, that they may be healed If when infants are carried, they are said to have no birth-sin at all, and they come to Christ; why is it not said in the Church to those who bring them?—Away with these innocents hence; they that are whole need not a physician, but they that are sick; Christ came not to call the righteous, but sinners.” It was never so said; nay, nor ever will it be so said.” [Aug. Serm. 174 and 176, Ben., 124 and 126, Oxf. transl.] In the primitive Office for Baptism, which is noticed in the previous Introduction, “infants” are distinctly mentioned; and the twenty-seventh Article of Religion testifies to the ancient practice of our own Church, when it says, “The Baptism of young children is in any wise to be retained in the Church, as most agreeable with the institution of Christ.”

The necessity of Holy Baptism to salvation is so urgent, and the blessings conferred by it so great, that Infants should be brought to the font as early as possible. Baptism is often delayed until the mother is able to be present with her child; but however pleasing this may be to her feelings, such a delay is very undesirable, for the spirit in which children are brought to Baptism should be that in which our Lord vouchsafed to come to Circumcision,—“I made haste, and delayed not, to keep Thy commandments.” The Rubric at the commencement of the Office for Private Baptism, plainly shows the mind of the Church on this subject: “The Curates of every Parish shall often admonish the people, that they defer not the Baptism of their children longer than the first or second Sunday next after their birth, or other holy-day falling between, unless upon a great and reasonable cause, to be approved by the Curate.”

THE INTRODUCTORY RUBRICS.

Sundays, and other Holy-days] In the Primitive Church the seasons of Epiphany, Easter, and Pentecost were those at which Baptism was administered, except urgent necessity required its administration at other times; and the two latter were the times

which cause also it is expedient that Baptism be ministered in the vulgar tongue. Nevertheless (if necessity so require), Children may be baptized upon any other day.

¶ And note, that there shall be for every Male-child to be baptized two Godfathers and one Godmother; and for every Female, one Godfather and two Godmothers.

¶ When there are Children to be baptized, the Parents shall give knowledge thereof over night, or in the morning before the beginning of Morning Prayer, to the Curate. And then the Godfathers and Godmothers, and

In primo deferatur infans ad valvas ecclesie, Salisbury Use. et inquirat Sacerdos ab obstetrice, utrum sit Ad faciend. Catechum. infans masculus an femina. Deinde, si infans fuerit baptizatus domi: et quo nomine vocari debeat Masculus autem

principally used in the Western Church. The third Canon of the Council of Maçon [A.D. 585] forbids Baptism at any other time than Easter, meaning probably the whole season between Easter Eve and Whitsuntide, and many mediæval councils repeat the injunction. One of the Rubrics of the Salisbury Manual is as follows:—“¶ *Solemnis baptismus celebrari solet in Sabbato sancto Paschæ et in vigilia Pentecostes, et ideo pueri nati infra octo dies ante Paschæ, vel infra octo dies ante Pentecosten, debent reservari ad baptizandum in Sabbato sancto Paschæ vel in vigilia Pentecostes, si commode et sine periculo valeant reservari.*” From 1549 to 1661 the following rubrical Introduction, taken from Hermann’s Consultation, stood before the Offices for Baptism, but the present Rubric was substituted in the latter year:—“It appeareth by ancient writers, that the Sacrament of Baptism in the old time was not commonly ministered but at two times in the year, at Easter and Whitsuntide; at which times it was openly ministered in the presence of all the congregation: which custom (now being grown out of use), although it cannot for many considerations be well restored again, yet it is thought good to follow the same as near as conveniently may be¹. Wherefore the people are to be admonished, that it is most convenient that Baptism should not be ministered, but upon Sundays and other holy-days, when the most number of people may come together: as well for that the congregation there present may testify the receiving of them that be newly baptized into the number of Christ’s Church; as also because in the baptism of infants every man present may be put in remembrance of his own profession made to God in his baptism. For which cause also it is expedient that baptism be ministered in the English tongue. Nevertheless (if necessity so require), children ought at all times to be baptized either at the Church or else at home.” But the tendency of the Rubrics, in later times, has been that indicated in the last note: and additional facilities were offered to the people for the Public Baptism of their children in Church, with the intention, probably, of discouraging lay-baptisms at their own houses.

It should be clearly understood also that the facilities offered for Public Baptism are extended to every Sunday and Holy-day by an express Canon of the Church, and do not depend only on the construction to be put upon the Rubric. It is as follows:—

“Canon 68.

“Ministers not to refuse to Christen or Bury.

“No Minister shall refuse or delay to christen any child according to the form of the Book of Common Prayer that is brought to the Church to him upon Sundays or Holy-days, to be christened, or to bury any corpse that is brought to the Church or Churchyard, convenient warning being given him thereof

¹ In Cranmer’s answer to the Devonshire rebels, he speaks of the consecration of the font at Easter and Whitsuntide as having become an unmeaning ceremony, for “except it were by chance, none were baptized, but all were baptized before.” Strype’s Memorials of Cranmer, ii. 533. Ecc. Hist. Soc. The custom of blessing the fonts on Easter Eve sprung out of the primitive usage, which also restricted this benediction to the Bishop.

before, in such manner and form as is prescribed in the said Book of Common Prayer. And if he shall refuse to christen the one, or bury the other (except the party deceased were denounced excommunicated *majori excommunicatione*, for some grievous and notorious crime, and no man able to testify of his repentance), he shall be suspended by the Bishop of the diocese from his ministry by the space of three months.”

In interpreting this Canon, due regard must be paid to the expression, “according to the form of the Book of Common Prayer,” since this “form” limits the time of Baptism to “after the last lesson” at Morning or Evening Prayer, and the clergyman would not be bound to baptize a child brought to the Church at a later time of the service, or when there is neither Mattins nor Evensong. “Convenient warning” has also been defined as being “warning of the intention to bring,” and reasonably means at least the evening before, as in the rubric.

And note . . . two Godfathers and one Godmother] The Rubric on this subject, at the end of our ancient baptismal office, is as follows:—“Non plures quam unus vir et una mulier debent accedere ad suscipiendum parvulum de sacro fonte: unde plures ad hoc simul accedentes peccant faciendo contra prohibitionem canonis, nisi alia fuerit consuetudo approbata: tamen ultra tres amplius ad hoc nullatenus recipiantur.” Yet in a Legatine Council, held at York by Hubert, Archbishop of Canterbury, in 1195, and in a Constitution of Edmund, Archbishop of Canterbury in 1236, there is a provision exactly similar to that in our present Rubric: “Ad levandum vero puerum de fonte, tres ad plus recipiantur; videlicet in baptismo maris duo mares et una femina; in baptismo femine, due femine, et unus masculus; quod enim amplius est a malo est.” [Gibson’s Codex, 439.] The primitive practice of the Church appears to have been identical with that of the Eastern and the Latin Church at present, in which only one Sponsor is required, although two are permitted. [Duty of Parish Priests, iii. 10; Conc. Trident. xxiv. 2.] In the ancient English exhortation, printed at the end of this Office, it will be seen, that one Godfather and one Godmother are named: and it may be doubted whether three Sponsors were ever actually required until 1661, when the present Rubric was inserted by Bishop Cosin. The twenty-ninth Canon forbids parents to be sponsors for their own children, and in this follows the old Rubric: “¶ *Similiter pater vel mater non debet proprium filium de sacro fonte levare*,” but this Canon was altered by the Convocation of Canterbury in 1865, and the prohibition scarcely holds now. This change practically reduces the number of sponsors to one again, as the father and mother are already responsible, *in the highest degree*, as Christian parents: but it would be well for the spirit of the ancient rule to be carried out by some one who is *not* the parent taking the baptized child from the hands of the priest who has baptized it².

² The above rubric ends: “*nec baptizare, nisi in extrema necessitate articulo, tunc enim bene possunt sine præjudicio copula conjugatis ipsium*”

the people with the Children, must be ready at the Font, either immediately after the last Lesson at Morning Prayer, or else immediately after the last Lesson at Evening Prayer, as the Curate by his discretion shall appoint. And the Priest coming to the Font (which is then to be filled with pure Water), and standing there shall say,

Eph. iv. 5.

HATH this Child been already baptized, or no?

¶ *If they answer, No: Then shall the Priest proceed as followeth.*

Job xiv. 4. xxv.
Ps. li. 5.
John iii. 6. xiv.
6.

DEARLY beloved, forasmuch as all men are conceived and born in sin; and that our Saviour Christ

statuetur a dextris Sacerdotis: mulier vero a sinistris.

BELOVED in Christ Jesu, we hear Daye's transl. of Herman's Consult., A.D. 1547. daily out of the word of God and learn by our own experience; that

immediately after the last Lesson] In the Primitive Church it was the custom to confirm Infants as soon as they were baptized, and then to administer to them a small particle of the consecrated bread moistened with the consecrated wine. Hence Baptism was administered (as may be seen by the ancient Sacramentary of St. Gregory) immediately before the celebration of the Holy Eucharist. This was probably the custom also in the mediæval Church: and in Daye's translation of Archbishop Hermann's book [A.D. 1547] are the words, "Our mind is that the handling of the Sacrament of Christ's body and blood, called Eucharistia, may be joined with Baptism, and that they which bring the Infants to Baptism may use the body and blood of our Lord Jesus Christ after the manner and institution of the Primitive Church!" In the Prayer Book of 1549, the times appointed for Baptism were "either immediately afore the last Canticle at Mattins, or else immediately afore the last Canticle at Evensong," as by the present Rubric.

And the Priest coming to the Font] In the Prayer Book of 1549 the sponsors were directed to be ready at the church door, where the priest came to them, and said the first part of the service as far as the Exhortation before the Interrogatories. This Rubric and benediction followed: "¶ *Then let the Priest take one of the children by the right hand, the other being brought after him. And coming into the Church toward the font, say, The Lord vouchsafe to receive you into His holy household, and to keep and govern you always in the same, that you may have everlasting life. Amen.*" This usage was dropped in 1552. In 1661 the Presbyterians wished the font to "be so placed as all the congregation may best see and hear the whole administration;" but the Bishops replied, "The font usually stands, as it did in primitive times, at or near the Church door, to signify that Baptism was the entrance into the Church mystical: 'we are all baptized into one body' [1 Cor. xii. 12], and the people may hear well enough." A large stone font, actually filled with pure water, and having a drain by which the blessed water may be let off after the Baptism, is plainly contemplated by the Rubric, and is directly enjoined by the eighty-first Canon. Some decorous vessel should be provided for bringing the water to the font, so as to avoid the use of an ordinary domestic pail or can. The ancient Salisbury Rubric is instructive: "¶ *Presbyter autem si poterit semper habeat fontem lapideum, integrum, et honestum, ad baptizan-*

baptizare, nisi fuerit aliquis alius præsens qui hoc facere sciret et vellet. As parents are the means of transmitting original sin to their offspring [2 Pet. i. 4], the reason of this rule is sufficiently evident. Innocent and holy as the married state is [and *ἐπιθυμία* does not imply sin: cf. Gal. v. 17], yet this should not be overlooked as a reverent reason against any baptism of a child by its father without extreme necessity, and *à fortiori* against the unseemliness of such a Baptism in the face of the Church.

¹ This partly accounts for the strictness of the 29th Canon in requiring that Sponsors shall be communicants.

dum: si autem nequiverit, habeat vas conveniens ad baptismum quod aliis usibus nullatenus deputetur, nec extra ecclesiam deportetur."

THE INTRODUCTORY SERVICE.

The ancient division of the Baptismal Office into three parts is still to be clearly traced, as will be seen from the subsequent notes, and marginal references in the right-hand column. The Introductory portion answers to the Admission of a Catechumen; and extends as far as the end of the Collect which precedes the exhortation to the Godfathers and Godmothers.

Hath this Child been already baptized, or no?] The actual words of this question were substituted for the rubrical direction, "*The Priest shall ask whether the children be baptized or no,*" in 1661. In Bishop Cosin's Durham Book, the MS. rubric as amended by him stands, "*And the Priest, coming to the Font, which is then to be replenished with pure water, and standing there shall say, Hath this child been already baptized or no? Or if there be more, Hath any one of these children? varying the Form only in those words which are requisite to express a difference of the sex or number of the children.*" The question is one of importance, as, in the words of Hooker, "iteration of Baptism once given hath been always thought a manifest contempt of that ancient apostolic aphorism, 'One Lord, one Faith, one Baptism,' baptism not only one inasmuch as it hath every where the same substance, and offereth unto all men the same grace, but one also for that it ought not to be received by any one man above once" [Ecc. Polit. V. lxii. 4]. This is the unvarying doctrine of the Church, the only diversity of opinion on the subject being in respect to what constitutes true baptism. Care should therefore be used on both sides to secure a distinct answer to this question with respect to every child brought to the font; so as to avoid mistakes and accident through deafness or want of understanding.

If they answer, No:] For the course to be followed in case the contrary answer "Yes" is given, see the notes at the beginning of the Office for Private Baptism.

Dearly beloved, forasmuch as all men] The address which follows, although partly suggested by that in Archbishop Hermann's "Consultation," seems to have been adopted with a knowledge of that in the ancient Baptismal Office of the French Church, which is not unlikely to have been handed down from the time of Polycarp and St. John. The following is a translation:—"Very dear Brethren, let us, in the venerable office of the present mystery, humbly pray our Almighty Creator and Restorer, who deigned to repair, through grace, the glories of our nature, lost through sin, that He will transfuse efficacy into these waters and by the presence of the Majesty of the Trinity, give power to effect the most holy regeneration; that He will break in pieces

saith, None can enter into the kingdom of God, except he be regenerate and born anew of Water and of the holy Ghost; I beseech you to call upon God the Father, through our Lord Jesus Christ, that of his bounteous mercy he will grant to *this Child* that thing which by nature he cannot have; that *he* may be baptized with Water and the holy Ghost, and received into Christ's holy Church, and be made a *lively member* of the same.

Matt. xviii. 19,
20.
Eph. ii. 3.
Acts i. 5.
Tit. iii. 5, 6.
Acts ii. 41, 47.
1 Cor. xii. 12-14.
Rom. vi. 3, 4, 11.

¶ *Then shall the Priest say,*

Let us pray.

Gen. vi. 13, 17,
18, vii. 21-23.
1 Pet. iii. 20, 21.
Exod. xiv. 26-31.
1 Cor. x. 1, 2.
Matt. iii. 13-17.
Acts xxii. 16.
Mark xvi. 16, x.
13-16.
1 Cor. vi. 11, vii.
14.
Acts ii. 47.
1 Thess. i. 10.
1 Cor. xiii. 13.
1 Pet. v. 9.
Rom. xv. 13.
Col. iii. 14.
John xvi. 33.

ALMIGHTY and everlasting God, who of thy great mercy didst save Noah and his family in the ark from perishing by water; and also didst safely lead the children of Israel thy people through the Red Sea, figuring thereby thy holy Baptism; and by the Baptism of thy well-beloved Son Jesus Christ, in the river Jordan, didst sanctify Water to the

all we, from the fall of Adam, are conceived and born in sins

Let us pray.

Daye's transl. of
Herman's Con-
sult., A.D. 1547.

FURTHER, Almighty God, which in old time didst destroy the wicked world with the flood, according to thy terrible judgment, and didst preserve only the family of godly Noah, eight souls, of thy unspeakable mercy: and which also didst drown in the Red Sea obstinate Pharaoh the king of the Egyptians, with all his army and warlike power, and causedst thy people of

the head of the dragon upon these waters; and that the debtors being buried with Christ by Baptism, the likeness of death may so take place here, that the perishing may be saved, and death may only be felt in the destruction here on earth through Jesus Christ."

Then shall the Priest say, Let us pray] There is no rubric here directing the position of the Priest or the People: the Durham book, however, shows the practice of the Church. A rubric is there inserted after "Let us pray," "*And here all the congregation shall kneel down,*" which rubric is printed in the Service for "Baptism of such as are of riper years," and therefore defines the position of the people. That of the clergyman has already been defined by the rubric, "*The Priest coming to the Font . . . and standing there.*" Both are confirmed by the rubric following these two prayers, "*Then shall the people stand up, and the Priest shall say.*" The clergyman should not kneel at all during the administration of the Sacrament of Baptism, unless at the Lord's Prayer, when the rubric, "*Then shall be said, all kneeling,*" may possibly include him as well as the people. His standing during the former parts of the Office is in token that he is the minister of God, commissioned authoritatively to give the outward sign by which inward grace is conveyed. The "all kneeling" rubric was added by Bishop Cosin in 1661; and if it includes the Priest, must be taken as intended to show that the authoritative act is over, and that the Minister of God is now the mouth-piece of the people in offering up a humble thanksgiving. It may be added that this thanksgiving does not, as in the case of the Holy Communion, form an essential part of the rite. In that case the Priest stands as still continuing the act of Sacrifice, but here the sacramental act is completed before the child leaves his arms.

Almighty and everlasting God, who] This prayer is not derived from the old Office of the English Church, but is probably of great antiquity. Luther translated it into German from the ancient Latin in 1523, and it appears again in his revised "Baptismal Book" of 1524. From thence it was transferred to the Nuremberg Office, and appears in the "Consultation" of Archbishop Hermann in 1545. The latter was translated into

English in 1547, and the prayer as it stands in the Prayer Book of 1549 is almost identical with this translation, as given above.

didst save Noah . . . by water] The type of the deluge was used in two senses in the original, as will be seen above; first, indicating water as a means of destroying evil; and, secondly, as a means of salvation. The first sense was eliminated from the prayer in 1552, as also was the similar passage which spoke of the destruction of Pharaoh: and in its present form the idea of "saving by water" is more strongly expressed than it was previously by "whom . . . thou didst save in the ark." Yet the original twofold sense is to be found in the Gelasian office for Baptism,—"*Who, washing away the sins of the world by water, didst in the very outpourings of the deluge, stamp a figure of regeneration; so that through the mystery of one and the same element, there was both an end put to sins, and a source of excellence.*" The Baptism of the world by the deluge to the cleansing away of its iniquity, and the regenerating it for a new life, is a favourite idea with the ancient fathers¹.

didst sanctify Water] Every ancient Baptismal Office contains this reference to the effect of our Lord's Baptism in sanctifying the element of water, and yet it is remarkable that no such doctrine is to be found in Holy Scripture. It is one of those venerable religious impressions which pervade the whole Church of Christ, and which, at the same time, cannot be traced up to their origin². The words were objected to by the Presbyterians at the Savoy Conference, but happily the Bishops retained them; with the explanation that the Baptism of Christ was "dedicatio baptismi." Compare this Prayer with that in the Baptism of Adults.

The signing with the Cross which now follows the act of Baptism, took place here in the Prayer Book of 1549, the words used being "*N.*" (the child having been named by the sponsors), "Receive the sign of the holy cross, both in thy forehead and in thy breast, in token that thou shalt not be ashamed . . ." &c.

¹ Scriptural Views of Baptism, 302, n.

² The Benediction of the Waters of the Neva in the Russian Church is connected with this tradition.

Rev. vi. 14, 15.
xxii. 5, 14.

mystical washing away of sin; We beseech thee, for thine infinite mercies, that thou wilt mercifully look upon *this Child*; wash *him* and sanctify *him* with the holy Ghost; that *he*, being delivered from thy wrath, may be received into the ark of Christ's Church; and being stedfast in faith, joyful through hope, and rooted in charity, may so pass the waves of this troublesome world, that finally *he* may come to the land of everlasting life, there to reign with thee world without end; through Jesus Christ our Lord. *Amen.*

1 Tim. vi. 15, 16.
Isa. xxv. 4.
2 Cor. vi. 2.
John xi. 25, 26.
Matt. xviii. 11.
Acts ii. 38, 39.
Tit. iii. 3.
1 Sam. i. 27, 28.
Matt. vii. 7, 8.
Luke xi. 13.
James v. 16.
1 John v. 6-8.
1 Cor. vi. 11.
Rev. i. 5, 6.

ALmighty and immortal God, the aid of all that need, the helper of all that flee to thee for succour, the life of them that believe, and the resurrection of the dead; We call upon thee for *this Infant*, that *he*, coming to thy holy Baptism, may receive remission of *his* sins by spiritual regeneration. Receive *him*, O Lord, as thou hast promised by thy well-beloved Son, saying, Ask, and ye shall have; seek, and ye shall find; knock, and it shall be opened unto you: So give now unto us that ask; let us that seek find; open the gate unto us that knock; that *this Infant* may enjoy the everlasting benediction of thy heavenly washing, and may come to the eternal kingdom which thou hast promised by Christ our Lord. *Amen.*

Israel to pass over with dry feet, and wouldest shadow in them holy Baptism the laver of regeneration. Furthermore, which didst consecrate Jordan with the Baptism of thy Son Christ Jesu, and other waters to holy dipping, and washing of sins; we pray thee for thy exceeding mercy look favorably upon this infant, give him true faith and thy holy Spirit, that whatsoever filth he hath taken of Adam, it may be drowned, and be put away by this holy flood, that being separated from the number of the ungodly, he may be kept safe in the holy ark of the church, and may confess and sanctify thy name with a lusty and fervent spirit, and serve thy Kingdom with constant trust, and sure hope, that at length he may attain to the promises of eternal life with all the godly. *Amen.*

DEUS, immortale præsidium omnium postulantium, liberatio supplicum, pax rogantium, vita credentium, resurrectio mortuorum: te invoco super hunc famulum tuum N. qui Baptismi tui donum petens, æternam consequi gratiam spirituali regeneratione desiderat. Accipe eum, Domine: et quia dignatus es dicere, petite ac accipietis, quærite et invenietis, pulsate et aperietur vobis, petenti præmium porrige et januam pande pulsanti: ut æternam celestis lavacri benedictionem consecutus, promissa tui muneris regna percipiat. Qui vivis et regnas cum Deo Patre in unitate Spiritus Sancti Deus, per omnia sæcula sæculorum. *Amen.*

Salisbury Use.
Ad faciend.
Catechum.

Almighty and immortal God, the aid] This is from the Salisbury Office, where, and in the Prayer Book of 1549, it was associated with the Exorcism. The latter followed the prayer in the first Prayer Book, in this form:

¶ *Then let the Priest, looking upon the children, say,*

"I command thee, unclean spirit, in the name of the Father, of the Son, and of the Holy Ghost, that thou come out and depart from these infants, whom our Lord Jesus Christ hath vouchsafed to call to His holy Baptism, to be made members of His body, and of His holy congregation. Therefore, thou cursed spirit, remember thy sentence, remember thy judgment, remember the day to be at hand wherein thou shalt burn in fire everlasting, prepared for thee and thy angels. And presume not hereafter to exercise

any tyranny towards these infants, whom Christ hath bought with His precious blood, and by this His holy baptism calleth to be of His flock."

This was founded on the ancient exorcism, but was not quite identical with it in the latter part. Both it, and the *Dominus vobiscum* which followed it, were left out in the revision of 1552. The exorcism seems to have been expunged in deference to the criticism of Bucer, who thought that it pointed to an actual possession of all unbaptized persons, similar to the cases of possession recorded in the Gospel. It was an usage derived from the Primitive Church, and showed a more sensitive appreciation of the actual power and presence of the Evil One than the half-sceptical Germanism of Bucer could understand; but it can hardly be regretted that it is not in our present office.

THE PUBLIC BAPTISM OF INFANTS.

¶ *Then shall the people stand up, and the Priest shall say,*

Hear the words of the Gospel, written by Saint *Mark*, in the tenth Chapter, at the thirteenth Verse.

His dictis, dicat sacerdos,

Dominus vobiscum. *Resp.* Et cum spiritu tuo. *Sequentia sancti Evangelii secundum Matthæum. Resp.* Gloria tibi, Domine.

Salisbury Use.
*Ad faciend.
Catechum.*

	<i>Modern English.</i>	<i>Salisbury Use.</i>	<i>Modern Roman.</i>	<i>Eastern.</i>
EPISTLE.				Rom. vi. 3—12.
GOSPEL.	Mark x. 13—16.	Matt. xix. 13—15.	Matt. xix. 13—15.	Matt. xxviii. 16—20.

¶ *After the Gospel is read, the Minister shall make this brief Exhortation upon the words of the Gospel.*

BELOVED, ye hear in this Gospel the words of our Saviour Christ, that he commanded the children to be brought unto him; how he blamed those that would have kept them from him; how he exhorteth all men to follow their innocency. Ye perceive how by his outward gesture and deed he declared his good will toward them; for he embraced them, in his arms, he laid his hands upon them, and blessed them. Doubt ye not therefore, but earnestly believe, that he will likewise favourably receive *this present Infant*; that he will embrace *him* with the arms of his mercy; that he will give unto *him* the blessing of eternal life, and make *him* partaker of his everlasting kingdom. Wherefore we being thus persuaded of the good will of our heavenly Father towards *this Infant*, declared by his Son Jesus Christ; and nothing doubting but that he favourably alloweth this charitable work of

Matt. xxi. 21, 22.
Mark ix. 23, 24.
Luke xi. 15, 16.
John x. 27, 28.
Eph. v. 20.

Believe these words and this deed of our Lord Jesus Christ upon them, and doubt not but that he will so receive your children also, and embrace them with the arms of his mercy, and give them the blessing of eternal life, and the everlasting communion of the kingdom of God. The same Lord and our Saviour Jesus Christ confirm and increase this your faith. Amen.

Daye's transl of
Hermann's Con-
sult., A. D. 1547.

Hear the words of the Gospel] The practice of former days at the reading of the Gospel in the Baptismal Office appears to have been identical with that used at the same rite in the Communion Service, for Bishop Cosin inserted the following in his Prayer Book prepared for the Revision of 1661. Before the Gospel, "*Here the people shall stand up and say, Glory be to Thee, O Lord!*" and after the Gospel, "*So endeth the Holy Gospel. Answer. Thanks be to Thee, O Lord!*" In the ancient Offices these versicles were sometimes inserted, and in some cases (as in our modern one) left out. Reverence and analogy both suggest their use.

The parallel passage from St. Matthew's Gospel was used in some Baptismal Offices (as in those of Beauvais and Remiremont) [Martene de Antiq. Ecc. i. 43] as long as eight hundred years ago, and is probably of as ancient a date in our own Office, although not traceable in the Sacramentaries of the Primitive Church. It was changed for the present Gospel from St. Mark in 1549, perhaps for the sake of the emphatic words of our Lord with which the passage concludes in that Evangelist, and which were a Divine witness against the Anabaptist heresy that infested the Churches

of Europe at the time of the Reformation. It was also appointed in Hermann's "Consultation."

Beloved, ye hear in this Gospel] This address, or short homily, was first inserted in 1549, and was evidently founded on that in the Cologne book. In its original form [1549] it ended "and say the prayer which the Lord himself taught. And in declaration of our faith, let us also recite the articles contained in our Creed." The Lord's Prayer and the Creed were then said (according to the ancient custom) by "the Minister, godfathers, godmothers, and people present," before the prayer which now immediately follows the Exhortation. This recitation of the Lord's Prayer and Creed was made by all, on their own behalf, and was quite independent of the interrogatory Creed which is recited by the Priest, and replied to by the sponsors on behalf of the child to be baptized. It is singular that, although the Lord's Prayer has been removed from this Office, it is retained in the parallel one for publicly receiving a privately baptized child.

alloweth] An old word for "approves and accepts," i. e. "indorses." Cf. Luke xi. 48, where the original word *συμυνοκεῖρε* fixes the sense.

ours in bringing *this Infant* to his holy Baptism; let us faithfully and devoutly give thanks unto him, and say,

1 Pet. i. 3.
2 Pet. i. 3.
2 Tim. i. 9.
Rom. xvi. 25—27.
1 Cor. i. 7, 8.
Luke xi. 13.
John iii. 3—7, 16.
Heb. v. 9.
Eph. iii. 14—21.

ALMIGHTY and everlasting God, heavenly Father, we give thee humble thanks, for that thou hast vouchsafed to call us to the knowledge of thy grace, and faith in thee: Increase this knowledge, and confirm this faith in us evermore. Give thy holy Spirit to *this Infant*, that he may be born again, and be made an heir of everlasting salvation; through our Lord Jesus Christ, who liveth and reigneth with thee and the Holy Spirit, now and for ever. *Amen.*

¶ *Then shall the Priest speak unto the God-fathers and Godmothers on this wise.*

DEARLY beloved, ye have brought *this Child* here to be baptized, ye have prayed that our Lord Jesus Christ would vouchsafe to receive *him*, to release *him* of his sins, to sanctify *him* with the holy Ghost, to give *him* the kingdom of heaven, and everlasting life. Ye have heard also that our Lord Jesus Christ hath promised in his Gospel to grant all these things that ye have prayed for: which promise he, for his part, will most surely

Deut. vii. 9.
Eph. i. 3—7.
2 Cor. i. 20.

ALMIGHTY and everlasting God, heavenly Father, we give thee eternal thanks, that thou hast vouchsafed to call us to this knowledge of thy grace, and faith towards thee. Increase and confirm this faith in us evermore. Give thy holy Spirit to this infant, that he may be born again, and be made heir of everlasting salvation, which of thy grace and mercy thou hast promised to thy holy Church, to old men and to children, through our Lord Jesus Christ, which liveth and reigneth with thee now and for ever. *Amen.*

Daye's transl. of
Herman's Con-
sult., A.D. 1547.

BELOVED in Christ, yesterday by the grace of God we heard how exceeding and unspeakable mercy is exhibited in Baptism. Ye have renounced Satan and the world, ye have confessed the faith of Christ, and ye have promised obedience to Christ, and the congregation, and ye have required of God the Father that for His Son's sake our Lord Jesus Christ, He will deliver these infants from the kingdom of darkness, and settle them in the

Daye's transl. of
Herman's Con-
sult., A.D. 1547.

Almighty and everlasting God] The Collect which follows the Exhortation is not from the ancient Offices of the English Church, but is taken from the Cologne Book of Archbishop Hermann. It may have been taken into that book, like the first prayer in the Office, from ancient German rituals. The first half of it is on behalf of the congregation, and is plainly inserted with reference to the Creed which originally preceded it: the latter is a prayer on behalf of the child to be baptized, in which the Church beseeches God that it may be made partaker by baptismal regeneration of the inheritance of "everlasting salvation." The words of the Latin in Hermann's original are, "Da huic infanti Spiritum Sanctum tuum quo regeneretur, et hæres fiat æternæ salutis." They must not be taken as referring to any expected indwelling of the non-incarnate God, the Holy Ghost, in the individual, but to the operation upon the individual of that Third Person in the Blessed Trinity, Who ever indwells in the Church as a corporate body, according to the promise of our Lord. The prayer has some analogy with the Invocation of the Holy Ghost which is found in ancient Eucharistic Liturgies, the person being, of course, substituted for the elements.

It is a common practice for the congregation to repeat this Collect after the Minister. Perhaps the custom has some connexion with the recitation of the Creed, by which it was (as has been shown) preceded until 1552. But a rubric stood before it in

the first book of Edward VI., "*The Priest shall add also this prayer,*" and there is nothing in the present book to indicate that it should be said by any one except the Priest.

Immediately after this Collect, according to the Office of 1549, the priest took the child (or one of the children) to be baptized by the hand, and went from the church door (where all the preceding parts of the Service had been performed), towards the font, saying, "The Lord vouchsafe to receive you into His holy household, and to keep and govern you alway in the same, that you may have everlasting life. Amen." This ancient custom seems originally to have been instituted with reference to adult catechumens, the leading of an infant by the hand which was being carried in its godmother's arms being clearly an adaptation, and not a very significant one, of an usage which was highly significant in the case of a grown-up person. As the service for the admission of the catechumen ceased now to be separate from that for his baptism, and as the baptismal office was now intended primarily for infants, though in primitive times intended primarily for adults who had been Jews or Heathens, the abolition of the practice appears to be not unreasonable: and the less so as it is substantially continued in the Baptism of Adults.

The introductory part of the Office, answering to the primitive and mediæval "*Ordo ad faciendum Catechumenum,*" now ends with this collect.

keep and perform. Wherefore, after this promise made by Christ, *this Infant* must also faithfully, for *his* part, promise by you that are *his* sureties, (until *he* come of age to take it upon *himself*;) that *he* will renounce the devil and all his works, and constantly believe God's holy Word, and obediently keep his commandments.

Deut. xxix. 9.
1 John iii. 6-10.
2 Tim. ii. 19.
Col. i. 21-23.

I demand therefore,

Eph. vi. 10-12.
1 John ii. 15, 16.
Rom. viii. 6, 12-14.
Tit. ii. 11-14.

DOST thou, in the name of this Child, renounce the devil and all his works, the vain pomp and glory of the world, with all covetous desires of the same, and the carnal desires of the flesh, so that thou wilt not follow, nor be led by them?

Answer.

I renounce them all.

Minister.

DOST thou believe in God the Father Almighty, Maker of heaven and earth?

Kingdom of His beloved Son. You must remember these things, and doubt nothing but that we shall receive all these things that we require if we believe

Item Sacerdos dicat.

Salisbury Use.
Ritus Baptizandi.

N. Abrenuncias Sathanæ. Respondeant compatrini et commatrinx, Abrenuncio. Item Sacerdos. Et omnibus operibus ejus. R. Abrenuncio. Item Sacerdos. Et omnibus pompis ejus. R. Abrenuncio.

Item Sacerdos.

Salisbury Use.
Ritus Baptizandi
Greg. Gelas.

N. Credis in Deum Patrem omnipotentem, Creatorem cœli et terræ?

Respondeant: Credo.

THE BAPTISMAL VOWS.

With the Exhortation to the Sponsors the actual "Ritus Baptizandi" begins, as it began in the ancient Offices; but it is now intermingled with the Benediction of the Font; the chrism [anointing] and the chrisom [baptismal robe], with the lighted taper [symbol of the lamps of the ten virgins], are omitted, and a thanksgiving, with the Lord's Prayer, is added.

The earliest Christian writings, and even the Holy Scriptures, show that some form of interrogation always preceded Baptism. When the eunuch desired baptism from Philip the Deacon, the latter said, "If thou believest with all thine heart, thou mayest. And he answered and said, I believe that Jesus Christ is the Son of God." [Acts viii. 37.] It has also been commonly believed by sound interpreters that St. Paul's words to Timothy, "Fight the good fight of faith, lay hold on eternal life, whereunto thou art also called, and hast professed a good profession before many witnesses" [1 Tim. vi. 12], refer to this custom. Tertullian speaks of the renunciation of Satan, and the declaration of belief, as part of the ceremony for making Catechumens. [De Coron. iii.] St. Cyprian says [Ep. lxx. 2], "The very interrogatory which is put in Baptism is a witness of the truth;" and from his time forward some form or other of interrogation and of Baptismal Vow is frequently alluded to by the Fathers. In the earliest extant Baptismal Liturgy, that of Gelasius and Gregory, the interrogatories are identical with those of the Salisbury Manual as printed above; and as those now in use are substantially the same, it may be reasonably considered that the modern form represents that which was in use in the Primitive, and perhaps in the Apostolic Church.

§ *The Vow of Renunciation.*

The form of renunciation is referred to by Tertullian in these words: "We do in the Church testify, under the hand of a chief minister, that we renounce the devil and his pomp and his angels." St. Basil [de Sp. S. xxvii.] speaks of the same renunciation as one of the unwritten traditions and customs of the Church. St. Cyril of Jerusalem gives the form as, "I renounce

thee, Satan, and all thy works, and all thy pomp¹, and all thy service;" and he says that while the renunciation was being uttered the catechumen stood facing the West, as "the region of sensible darkness," and stretched out the arm as though actually speaking to the Evil One. The ancient Roman form is that of Gelasius and Gregory. The form of the Eastern Church is, "Dost thou renounce Satan, and all his works, and all his angels, and all his service, and all his pomp? *Answer.* I renounce them:" the renunciation being made three times, which seems to have been the ancient practice. The original English form also contained three renunciations, being as follows:—

"*N. Dost thou forsake the devil and all his works?*

"*Answer.* I forsake them all,

"*Minister.* Dost thou forsake the vain pomp . . . desires of the same?"

"*Answer.* I forsake them all.

"*Minister.* Dost thou forsake the carnal desires . . . nor be led by them?"

"*Answer.* I forsake them."

These were combined into one question and one answer in the revision of 1552, and continued in that form with the addition, "in the name of this child," and the word "forsake" altered to "renounce" in 1661, the changes being made by Bishop Cosin².

§ *The Vow of Belief.*

The profession of faith is founded on our Lord's words in Matt. xxviii. 19; and from the case of the eunuch in Acts viii. 37, it appears to have been required from the very first. It seems

¹ "Pomp" comes from *πομπή*, *pompa*, and means strictly a religious procession. The ancient form of the renunciation carries us back to the primitive days of Christianity, when all public games and shows among the Greeks and Romans were connected with idolatrous and Satanic ceremonies. In its later form the "pomp" is connected with the world; and Shakespeare seems to have had the Baptismal vow in view when he put into Wolsey's mouth the words, "Vain pomp and glory of this world, I hate ye." [Henry VIII. iii. 2.]

² See other forms of the renunciations, and of the Baptismal Office at large, in Asseman., Cod. Liturg. i. 174, ii. 211; and in Neale's Hist. Eastern Church, ii. 945.

And in Jesus Christ his only-begotten Son our Lord? And that he was conceived by the Holy Ghost; born of the Virgin Mary; that he suffered under Pontius Pilate, was crucified, dead, and buried; that he went down into hell, and also did rise again the third day; that he ascended into heaven, and sitteth at the right hand of God the Father Almighty; and from thence shall come again at the end of the world, to judge the quick and the dead?

And dost thou believe in the Holy Ghost; the holy Catholick Church; the Communion of Saints; the Remission of sins; the Resurrection of the flesh; and everlasting life after death?

Answer.

All this I stedfastly believe.

Minister.

Rom. x. 10.
Mark xvi. 16.
2 Chron. xx. 20.
Acts ii. 41.

WILT thou be baptized in this faith?

Answer.

That is my desire.

Minister.

Ecol. xii. 13.
Deut. v. 27—29.
vi. 25.
Matt. vii. 21—23.
xix. 17.

WILT thou then obediently keep God's holy will and commandments, and walk in the same all the days of thy life?

Answer.

I will.

Item Sacerdos: Credis et in Jesum Christum Filium ejus unicum Dominum nostrum, natum et passum? Salisbury Use.
Greg. Gelas.

Respondeant: Credo.

Item Sacerdos: Credis et in Spiritum Sanctum, sanctam Ecclesiam Catholicam, Sanctorum communionem, remissionem peccatorum, carnis resurrectionem, et vitam æternam post mortem? *Respondeant:* Credo.

TUNC interroget Sacerdos nomen infantis dicens: Quid petis? *Respondeant:* Baptismum. *Item Sacerdos:* Vis baptizari? *Respondeant:* Volo.

also to be required by our Lord's words, "He that *believeth* and is baptized" [Mark xvi. 16]: for as belief must necessarily, in adults, precede Baptism, so some confession of what is believed seems necessary as an outward evidence of belief. The object, however, is not that each person should declare his own private belief, but that he should assent to that of the Church. Tertullian [de Coron. iii.] speaks of such a confession being made in his time, "pledging ourselves to something more than the Lord hath prescribed in the Gospel;" that is, to a fuller Creed than the confession of belief in the Three Persons of the Blessed Trinity. Such a confession is extant in the case of Palmatus, who was baptized about A.D. 220, a few years after Tertullian wrote. It is as follows:—"Credis, ex toto corde, in Deum Patrem Omnipotentem, Factorem omnium visibilibus et invisibilibus? *Respondit Palmatus.* Credo. Et in Jesum Christum, Filium ejus? *Et ait,* Credo. Qui natus est de Spiritu Sancto ex Maria Virgine? *Palmatus respondit,* Credo. Et in Spiritum Sanctum: Sanctam Ecclesiam Catholicam: Remissionem peccatorum: et carnis resurrectionem? *Et exclamavit cum lachrymis Palmatus, dicens,* Credo, Domine¹." St. Cyprian, in his seventieth and seventy-sixth Epistles, gives part of a similar creed, and others are extant which were used at the baptism of various persons in the third and fourth century; this being, in

fact, the earliest use of the Apostles' Creed². St. Cyril [Catech. Lect. xix. 9] states that this profession of faith was made towards the East.

In our first English Office the three divisions of the Creed formed three separate questions, to each of which the answer "I believe" was given. They were put together under one question and answer in 1552, and were retained in that form in 1661, although Bishop Cosin wished to restore the old custom, and noted it accordingly in his revised book. The question, "Wilt thou be baptized in this faith?" represents the two questions, "What dost thou desire?" and, "Wilt thou be baptized?" of the old Office: which were altered to the present form in 1552.

§ The Vow of Obedience.

This is not represented in the primitive Offices of Baptism of the Sacramentaries, nor in that of the English Church before 1661. It first appears in Bishop Cosin's MS. annotations, the question beginning, "Dost thou promise that thou wilt obediently . . ." and the answer being, "I do promise." But it appears probable from Justin Martyr [Apol. i. 61] that a declaration of a similar kind was used in very ancient times in the Eastern Church.

¹ Heurtley's *Harmonia Symbolica*, p. 106.

² The Eastern Church uses the Nicene Creed at Baptism.

¶ *Then shall the Priest say,*

Rom. vi. 3-6.
Eph. iv. 20-24.
John iii. 6.

O MERCIFUL God, grant that the old Adam in *this Child* may be so buried, that the new man may be raised up in *him*. *Amen.*

Rom. viii. 6, 7.
2 Pet. iii. 18.

Grant that all carnal affections may die in *him*, and that all things belonging to the Spirit may live and grow in *him*. *Amen.*

Isa. xl. 29-31.
Rom. xvi. 20.
1 John v. 4.
Jude 23.
1 Cor. xv. 57.

Grant that *he* may have power and strength to have victory, and to triumph against the devil, the world, and the flesh. *Amen.*

Gal. iii. 26, 27.
2 Pet. i. 2, 3.
Phil. i. 9-11.
Jude 21.

Grant that whosoever is here dedicated to thee by our office and ministry, may also be endued with heavenly

Rev. xxii. 12, 20.

virtues, and everlastingly rewarded, through thy mercy, O blessed Lord

Rev. i. 18.

God, who dost live and govern all things, world without end. *Amen.*

DOMINE Deus æterne fiat locus iste dignus, in quem Spiritus sanctus influat: sepeliatur hic illic Adam vetus, resurgat novus:

Miss. Gallican.
Mabillon,
p. 363.

Moriatur omne quod carnis est, resurgat omne quod Spiritus. . . .

. . . . Quicumque hinc renuciaverint diabolo, da eis triumphare de mundo. Qui te in hoc loco invocaverit, tu eum cognoscas in regno

Quicumque hinc se sibi negaverit, te lucrifaciat: et per ministerium nostrum, et mysterium tuum consecratus tibi populus, æternis ad te præmiis consecratur. Per Dominum nostrum Jesum Christum.

All the interrogatories were formerly addressed to the child without any modifying expression, although they were, of course, intended to be answered by the sponsors, according to the Sarum rubric, "Respondeant compatriini et commatrinae." Among the fine-drawn objections, however, of Bucer in 1549, this was the subject of one; and the Presbyterians of 1661 objected to the answers being made in the name of the child at all. In Bishop Cosin's book there is written, "Dost thou, *in the name of this child,*" and the alteration was adopted: but the Revisers refused to go further. Bishop Cosin also altered the rubric which precedes the interrogatories into this form: "¶ Then shall the Priest demand of the godfathers and godmothers of every several child to be baptized, these questions following." Where many children are to be baptized, it would be almost impossible to repeat the questions in the case of every several child: and it may be considered sufficient, if care is taken, by tone, gesture (and repetition, where necessary), that the sponsors of every child really make the answers which are appointed. An answer for each child is that which is required, and this may be secured even when the interrogatories are put only once to the whole body of sponsors. It must at the same time be remarked, that in making these answers the sponsors are simply the mouthpiece of the child, and do not incur any responsibility on their own account in consequence, either as regards the child or themselves. Yet as each godfather and godmother makes them, they can hardly fail to have a keen consciousness of the fact that these very replies were once made on their own behalf; and the thought may well arise, How have the vows thus made been kept in subsequent years? "Baptism doth re-present unto us our own profession."

THE BENEDICTION OF THE WATER.

Although the element of water was sanctified to a sacramental purpose by our Blessed Lord when He was baptized in it Himself, it has ever been the practice of the Church to use a form of benediction upon that portion of water which was to be set apart for the administration of Baptism. From the words of Tertullian it would even seem that such a form was used over running streams: for after saying that there is no difference whether a man is baptized in the sea, in a pool, in a lake, in a river, or in a fountain, he adds that "all waters, from the ancient privilege of their origin, obtain, after prayer to God, the sacrament of sanctification." [De Baptism. iv.] St. Cyprian writes to Januarius in the

year 255, "The water must first be cleansed and sanctified by the priest, that it may be able, by Baptism therein, to wash away the sins of the baptized." [Ep. lxx.] St. Cyril of Jerusalem taught his candidates for Baptism in similar words: "Regard not the sacred laver as simple water, regard rather the spiritual grace given with the water . . . plain water, after the invocation of the Holy Ghost, and of Christ, and of the Father, gains a sanctifying power." [Catech. Lect. iii. 3.] St. Ambrose, in his treatise on the Sacraments, writes, "When the priest first comes to the baptistery, he exorcizes the creature of water, and afterwards makes an invocation and offers a prayer, that the font may be sanctified for the presence of the Eternal Trinity." In the Apostolical Constitutions, and in the Sacramentaries of Gelasius and St. Gregory, the actual form of benediction is given; and the ceremonies by which it was accompanied are indicated in the previous Introduction to this Office. The ancient "Benedictio Fontis" of the Church of England was of a similar character to that of the Gregorian Sacramentary.

In all these cases the Benediction of the water was a ceremony separate from, or at least not necessarily performed at the same time with, the administration of Baptism. The special times of its performance were Easter Eve and Whitsun Eve: and in the early Church the Bishop was the officiating minister. The impurity of water which has been kept for a long time rendered a more frequent benediction necessary when Baptism came to be administered on any Sunday or Holyday; and as there was no essential necessity for the presence of a bishop, the rite was eventually performed by the priest, from time to time, whenever the water was changed. This custom was continued in the reformed Prayer Book, the Office for the Benediction of the Font being placed at the end of the two Offices for Baptism, as follows:—

¶ *The water in the font shall be changed every month once at the least, and afore any child be baptized in the water so changed, the Priest shall say at the font these prayers following.*

"O Most Merciful God our Saviour Jesu Christ, Who hast ordained the element of water for the regeneration of Thy faithful people, upon Whom, being baptized in the river of Jordan, the Holy Ghost came down in likeness of a dove: send down, we

1 *Sacerdos*, used in an inclusive sense, as we use "minister;" the Bishop being then the minister of this rite.

Matt. iii. 16, 17.
John xix. 34.
1 John v. 6, 8.
Rev. i. 5, 6.
Math. xxviii. 18,
19.
1 Kings viii. 30.
Matt. xviii. 19.
2 Kings v. 10—14.
1 Tim. iv. 5.
Acts xxii. 16.
John i. 16.
Tit. iii. 5, 6.
Rom. viii. 15, 16.
Rev. xvii. 14.
ii. 10.

ALMIGHTY, everliving God, whose most dearly beloved Son Jesus Christ, for the forgiveness of our sins, did shed out of his most precious side both water and blood, and gave commandment to his disciples, that they should go teach all nations, and baptize them In the Name of the Father, and of the Son, and of the Holy Ghost; Regard, we beseech thee, the supplications of thy congregation: sanctify this Water to the mystical washing away of sin: and grant that *this Child*, now to be baptized therein, may receive the fulness of thy grace, and ever remain in the number of thy faithful and elect children; through Jesus Christ our Lord. *Amen.*

. . . . Benedico te per Jesum Christum Filium ejus unicum Dominum nostrum: qui te in Chana Galileæ . . . Qui te una cum sanguine de latere suo produxit: et discipulis jussit ut credentes baptizarentur in te dicens: Ite, docete omnes gentes, baptizantes eos in nomine Patris, et Filii, et Spiritus Sancti . . . Hæc nobis præcepta servantibus tu Deus omnipotens, clemens adesto, tu benignus aspira. . . Ut omnis homo hoc sacramentum regenerationis ingressus, in veræ innocentiae novam infantiam renascatur. Per Dominum. Qui tecum vivit.

Salisbury Use.
Benedictio Fontis.
Greg. Gelas.

beseech Thee, the same Thy Holy Spirit to assist us, and to be present at this our invocation of Thy holy Name: sanctify & this fountain of baptism, Thou that art the sanctifier of all things, that by the power of Thy word all those that shall be baptized therein may be spiritually regenerated, and made the children of everlasting adoption. Amen.

"O Merciful God, grant that the old Adam, in them that shall be baptized in this fountain, may be so buried, that the new man may be raised up again. Amen.

"Grant that all carnal affections may die in them; and that all things belonging to the Spirit may live and grow in them. Amen.

"Grant to all them which at this fountain forsake the devil and all his works, that they may have power and strength to have victory and to triumph against him, the world, and the flesh. Amen.

"Whosoever shall confess Thee, O Lord: recognize him also in Thy kingdom. Amen.

"Grant that all sin and vice here may be so extinct: that they never have power to reign in Thy servants. Amen.

"Grant that whosoever here shall begin to be of Thy flock: may evermore continue in the same. Amen.

"Grant that all they which for Thy sake in this life do deny and forsake themselves: may win and purchase Thee, O Lord, which art everlasting treasure. Amen.

"Grant that whosoever is here dedicated to Thee by our office and ministry: may also be endued with heavenly virtues, and everlastingly rewarded through Thy mercy, O blessed Lord God, Who dost live and govern all things world without end. Amen.

"The Lord be with you.

"Answer. And with thy spirit.

"Almighty, Everliving God, Whose most dearly beloved Son Jesus Christ, for the forgiveness of our sins, did shed out of His most precious side both water and blood, and gave commandment to His disciples that they should go teach all nations, and baptize them in the name of the Father, the Son, and the Holy Ghost: Regard, we beseech Thee, the supplications of Thy congregation, and grant that all Thy servants which shall be baptized in this water, prepared for the ministration of Thy holy Sacrament, may receive the fulness of Thy grace, and ever remain in the number of Thy faithful and elect children, through Jesus Christ our Lord."

In 1552 this separate benediction of the water was abolished, through the interference of Bucer. He objected to any benediction, but a portion of the service was, notwithstanding, incorporated with that for Baptism, to be used whenever the sacrament

is administered. The last prayer was retained for the actual benediction instead of the first, the only alteration made being the omission of the words, "prepared for the ministration of Thy holy Sacrament." It was changed into its present form in 1661; but in Bishop Cosin's revised book the words are much less pointed than they were ultimately made, being, ". . . this water, which we here bless in Thy Name, and dedicate to this holy action."

Although this benediction of the water of Baptism is not essential to the regeneration of the baptized person, like the affusion of the water upon him, it is a solemn recognition of the work of God in the Sacrament: a significant symbol of the Creator laying "the beams of His chambers"—the Temple of Christ's mystical body—"in the waters;" of the Spirit of God moving upon the face of the waters, for the purpose of new creation; of the Victor breaking in pieces the head of the dragon in those waters by means of which the power of the evil one is counteracted and defeated. Being a rite of so solemn a kind, it should be performed with reverence and exactness, and it is well to use the old custom of making the sign of the Cross in the water at the word "sanctify," though it is not now the practice to print the cross in the Prayer Book, as formerly, in the places where it is proper to use it¹. Care should also be taken not to repeat the benediction; and to avoid this the water should be let off from the font immediately after the conclusion of the Baptismal Office.

The four petitions with which the benediction of the water begins now, as it began when it was a separate service, are substantially taken from the ancient Ritual of the Gallican Church. They have no place in the Roman ritual, nor were they in the Latin Office of the English Church: but they probably belong to that ancient Ephesine rite of St. John, which formed the original basis of the Salisbury Use. The original form has a great resemblance to the Great Collect or Litany which begins the Eastern Baptismal Office.

During the suppression of the Prayer Book some forms of prayer were printed by Jeremy Taylor, to be used by those who

¹ St. Augustine writes, "In fine, what is, as all know, the sign of Christ, save the Cross of Christ? Which sign unless it be applied, whether to the brows of the believing, or to the very water out of which they are regenerated, or to the oil wherewith they are anointed, or to the sacrifice wherewith they are fed, none of these is duly performed." [Aug. in Joann. cxviii. 5.] And in another place he also says, "For with this sign of the Cross the Body of the Lord is consecrated, and the water of Baptism sanctified." [Serm. cxviii. de Temp.] The rubric of the Salisbury Office (at least as old as the time of St. Gregory) is, "Hic dividat sacerdos aquam manu sua dextra in modum crucis."

¶ Then the Priest shall take the Child into his hands, and shall say to the Godfathers and Godmothers,

Luke i. 59—63.
ii. 21.

Name this Child.

¶ And then naming it after them (if they shall certify him that the Child may well endure it) he shall dip it in the water discreetly and warily, saying,

Matt. xxviii. 19.

N I baptize thee In the Name of
• the Father, and of the Son,
and of the Holy Ghost. Amen.

¶ But if they certify that the Child is weak, it shall suffice to pour water upon it, saying the foresaid words,

N I baptize thee In the name of
• the Father, and of the Son,
and of the Holy Ghost. Amen.

Deinde accipiat Sacerdos infantem per latera Salisburie Use. in manibus suis, et interrogato nomine ejus, Ritus Baptiz. baptizet eum sub trina mersione, tantum Greg Gelas. sanctam Trinitatem invocando, ita dicens :

*N. Et ego Baptizo te in Nomine Patris.
Et mergat eum semel versa facie ad
aquilonem, et capite versus orientem :*

Et Filii :

*Et iterum mergat semel versa facie ad
meridiem :*

Et Spiritus Sancti : Amen.

*Et mergat tertio recta facie versus
aquam.*

loved the ancient customs ; and his prayer for the benediction of the font offers a beautiful devotional commentary upon the subject. It is as follows :—

“Our Blessed Lord and Saviour Jesus, Who was baptized of John in Jordan, Who walked upon the waters, Who converted water into wine, Who out of His precious side shed forth blood and water, the two sacraments of life unto His holy Church, and commanded His disciples to teach all nations, baptizing them with water in the Name of the Father, of the Son, and of the Holy Ghost : He bless and sanctify by His Holy Spirit this water, that it may be instrumental and effective of grace, of pardon, and sanctification. Hear us, O most gracious God, that whosoever shall be baptized in this water may be renewed by Thy grace, justified by Thy mercy, sanctified by Thy Spirit, preserved by Thy Providence, and guided by Thy Word : that in this water, springing from the Paradise of God, the soul [or, souls] presented unto Thee may be cleansed and purified, and that there may be added to Thy Church daily such as shall be saved in the day of Thy glorious appearing, O blessed Lord and Saviour Jesus. Amen.”

It must be remembered that the benediction of the water for Baptism is of a very different nature from the benediction of the elements with our Lord's own words in the Holy Eucharist. In the former case the blessing simply sets it apart for a very holy use, and effects no sacramental change in the element. The rite is not (so far as we know) of our Lord's institution, nor did He ever use such words respecting water as He used respecting the Eucharistic elements.

THE BAPTISM.

The whole of what goes before is a preparation for the few words and the simple action by which the Baptism, and therefore the regeneration, of the child is effected, and all that follows looks back to these either in thanksgiving or in exhortation. Great exactness is, therefore, necessary in the use of this part of the office ; (1) first, that the child may not lack any of the benefits of regeneration through any omission in the rite by which it is conveyed ; (2) and, secondly, that the priest may not have guilt upon his soul through depriving the child, by any such omission, of the means of salvation.

The essential parts of the rite have been already spoken of in the previous Introduction ; but it may here be repeated that without actual contact of the water with the person of the child, while the words are being spoken, there cannot be a Baptism. When and where immersion was the common practice, this contact of the water was inevitable ; but now that immersion is not used, some precautions are desirable.

1. The water should be *poured* upon the child according to the rubric, not sprinkled. This may be done from the hollow of the hand, or from a small shell of silver or other material.

2. The water should be poured freely over the head of the child, so that it may flow back into the font.

3. To effect this properly, and with a reverent regard to the nature of the rite, the cap of the child must be removed from its head.

4. The hand or shell should be deliberately filled with water before the words are spoken.

5. In reverent accordance with ancient and primitive practice, and also for the more certain contact of the water with the child, it should be poured on thrice,—at the naming of each Person of the Blessed Trinity.

It is most necessary that the act of Baptism should habitually be thoroughly performed, primarily (of course) for the sake of the child, whose eternal interests are involved, but also that the essential nature of the external rite may be made quite evident to the Laity, and that full confidence may be established in the ministrations of the Clergy.

There can be no question that affusion, if thoroughly performed, is amply sufficient for the due administration of the sacrament of Baptism. In such a climate as ours, with such habits as those of modern times, and all its consequences considered, the dipping of infants could seldom be seemly, and would often be attended with danger. The “weakness” of the rubric may justly be assumed (without supposing actual sickness) as the normal condition of infants brought up under such conditions. Although not recognized in the rubric until 1549, there can be little doubt that affusion was practised instead of immersion (at the discretion of the priest), in ancient as well as in modern times¹.

SIGNING WITH THE CROSS.

It has been already mentioned that in the Prayer Book of 1549 the sign of the Cross was made upon the forehead and breast of the child at an earlier part of the service. In the ancient office this signing took place at the very beginning of the service for making a catechumen. The words used in the first Prayer Book were these :—“*N. Receive the sign of the holy Cross, both in thy forehead, and in thy breast, in token that thou shalt not be ashamed to confess thy faith in Christ crucified, and manfully to fight under His banner against sin, the world, and the devil, and to continue His faithful soldier and servant*

¹ See Lyndewood in Maskell's Mon. Rit. I. ccix., Rituale Rom. De formâ Baptismi, and Catech. Trident. ii. 17. The latter speaks of affusion as the “general practice” at that time, the middle of the sixteenth century.

1 Cor. xii. 13.
John x. 11. 16.
Rev. xxii. 4.
Gal. vi. 14.
Rom. i. 16.

+ Here the
Priest shall
make a cross
upon the
Child's fore-
head.

Matt. xvi. 24.
Eph. vi. 10, 11. 13.
1 Tim. vi. 12.
2 Tim. ii. 3, 4.
Rev. ii. 10.

¶ Then the Priest shall say,

WE receive this Child into the congregation of Christ's flock, and do sign him with the sign of the cross, in token that hereafter he shall not be ashamed to confess the faith of Christ crucified, and manfully to fight under his banner, against sin, the world, and the devil; and to continue Christ's faithful soldier and servant unto his life's end. Amen.

[Oratio.

DEUS Omnipotens, Pater Domini nostri Jesu Christi, qui te regeneravit ex aqua et Spiritu Sancto, quique dedit tibi remissionem omnium peccatorum tuorum: *Hic linit at infantem de ipso chrismate cum publice in vertice in modum crucis, dicens, Ipse te linit chrismate salutis in eodem Filio suo Domino nostro Jesu Christo in vitam æternam.*]

Salsbury Usa.

Ritus Baptiz.
Greg. Gelas.

[See also Rationale of 1541 in Collier's Ch. Hist. v. 106.]

unto thy life's end. Amen." The first part of these words came from the ancient service, and the general idea of the remaining part is taken from those which accompanied two other consignations, one at the naming, and the other at the exorcism of the child, both also in the office for making a catechumen. The anointing after the Baptism (and after the delivery of the Chrism) was continued in the first Prayer Book with the words of the ancient office, "*Then the Priest shall anoint the Infant upon the head, saying, Almighty God, the Father of our Lord Jesus Christ, who hath regenerate thee by water and the Holy Ghost, and hath given unto thee remission of all thy sins: He vouchsafe to anoint thee with the unction of His Holy Spirit, and bring thee to the inheritance of everlasting life. Amen.*"

Thus it will be seen that the present action and words represent the ancient usage, but that the use of anointing oil being discontinued and only the signing with the Cross retained, the words formerly used in the earlier part of the service were substituted here for those which referred to the act of unction; and "we receive this child into the congregation of Christ's flock, and do sign him with the sign of the Cross," for the opening words which were previously addressed to the child itself. As the thirtieth Canon distinctly says, the signing with the Cross adds nothing to the virtue and perfection of the Baptism, so also we must remember that neither are the accompanying words, "We receive," &c., any essential part of the Baptism. They have sometimes been spoken of as if by them the child was "received into the Church:" but the act of Baptism is the true reception into the Church, and these words are a ceremonial declaration only of that fact. In this respect they are analogous to the words used by the Priest in the Marriage Service, after the essential part of the office is completed by the solemn adjuration, "Those whom God hath joined together, let no man put asunder." As the Priest then "*pronounces*" that the married couple are "man and wife together," so here he "*pronounces*" that the baptized child has become one of the congregation of Christ's flock. This is made still more evident by the rubric and words of the Office for Private Baptism, "*. . . then shall not he christen the child again, but shall receive him as one of the flock of true Christian people, saying thus, I certify you . . . is now by the laver of Regeneration in Baptism received into the number of the children of God, and heirs of everlasting life . . .*" Neither the words nor the act have any sacramental efficacy, but it is clear (1) that the latter (as a substitute for unction) is the emphatic part of this most significant, venerable, and even primitive rite; and also that (2) any idea of an additional "reception into the Church" by the use of them tends to obscure the full completeness of that reception which is effected by the act of Baptism itself.

The superstitious antipathy which the Puritans entertained for the material figure and for the sign of the Cross led the reforming Divines to try and conciliate them by not printing it in the places where it was customary to use it in the services of the Church; but no pressure could prevail on them, in any of the revisions, to remove its obligatory use from the Baptismal

Office. It is not worth while to occupy any space with the always weak and often wicked arguments that were alleged against the use of this holy sign; but, as the thirtieth Canon [A.D. 1608] was framed as a general reply to them and is referred to in the rubric at the end of the service, it is inserted below as an illustration of the temperate yet firm line which the Reformers took on this subject¹.

1 CANON 30.

The Lawful Use of the Cross in Baptism explained.

We are sorry that his Majesty's most princely care and pains taken in the Conference at Hampton Court, amongst many other points, touching this one of the Cross in Baptism, hath taken no better effect with many, but that still the use of it in Baptism is so greatly stuck at and impugned. For the further declaration therefore of the true use of this ceremony, and for the removing all such scruple as might any ways trouble the consciences of them who are indeed rightly religious, following the royal steps of our most worthy King, because he therein followeth the rules of the Scriptures, and the practice of the primitive Church: we do commend to all the true members of the Church of England these our directions and observations ensuing.

First, it is to be observed, that although the Jews and Ethnicks derided both the Apostles and the rest of the Christians, for preaching and believing in Him who was crucified upon the Cross; yet all, both Apostles and Christians, were so far from being discouraged from their profession by the ignominy of the Cross, as they rather rejoiced and triumphed in it. Yea, the Holy Ghost by the mouths of the Apostles did honour the name of the Cross (being hateful among the Jews) so far, that under it He comprehended not only Christ crucified, but the force, effects, and merits of His Death and Passion, with all the comforts, fruits, and promises, which we receive or expect thereby.

Secondly, the honour and dignity of the name of the Cross began a reverend estimation even in the Apostles' times (for aught that is known to the contrary) of the sign of the Cross which the Christians shortly after used in all their actions: thereby making an outward show and profession, even to the astonishment of the Jews, that they were not ashamed to acknowledge Him for their Lord and Saviour, who died for them upon the Cross. And this sign they did not only use themselves with a kind of glory, when they met with any Jews, but signed therewith their children when they were christened, to dedicate them by that badge to His service, whose benefits bestowed upon them in Baptism the name of the Cross did represent. And this use of the sign of the Cross in Baptism was held in the primitive Church, as well by the Greeks as the Latins, with one consent and great applause. At what time, if any had opposed themselves against it, they would certainly have been censured as enemies of the name of the Cross, and consequently of Christ's merits, the sign whereof they could no better endure. This continual and general use of the sign of the Cross is evident by many testimonies of the ancient Fathers.

Thirdly, it must be confessed, that in process of time the sign of the Cross was greatly abused in the Church of Rome, especially after that corruption of Popery had once possessed it. But the abuse of a thing doth not take away the lawful use of it. Nay, so far was it from the purpose of the Church of England to forsake and reject the Churches of Italy, France, Spain, Germany, or any such like Churches, in all things which they held and practised, that, as the Apology of the Church of England confesseth, it doth with reverence retain those ceremonies, which do neither endanger the Church of God, nor offend the minds of sober men; and only departed from them in those particular points, wherein they were fallen both from themselves in their ancient integrity, and from the Apostolical Churches, which were their first founders. In which respect, amongst some other very ancient ceremonies, the sign of the Cross in Baptism hath been retained in this Church, both by the judgment and practice of those reverend Fathers and great Divines in the days of King Edward the Sixth, of whom some constantly suffered for the profession of the truth; and others being exiled in the time of Queen Mary, did after their return, in the beginning of the

¶ *Then shall the Priest say,*

1 Pet. i. 23.
Gal. iii. 27.
John xv. 5.
Rom. xi. 19, 20.
Ps. cvii. 21, 22.
Phil. i. 3, 6, 9—11.
Heb. iii. 14.

SEEING now, dearly beloved brethren, that *this child is* regenerate, and grafted into the body of Christ's Church, let us give thanks unto Almighty God for these benefits; and with one accord make our prayers unto him, that *this child* may lead the rest of *his* life according to this beginning.

¶ *Then shall be said, all kneeling,*

OUR Father, which art in heaven, Hallowed be thy Name. Thy kingdom come. Thy will be done in earth, As it is in heaven. Give us this day our daily bread. And forgive us, our trespasses, As we forgive them that trespass against us. And lead us not into temptation; But deliver us from evil. Amen.

¶ *Then shall the Priest say,*

Ps. cxi. 1.
Col. i. 12.
John iii. 6—8.
Gal. iv. 4, 5.

WE yield thee hearty thanks, most merciful Father, that it hath pleased thee to regenerate *this*

LAUDES et gratias Domino referamus, fratres dilectissimi, quod augere dignatus est ecclesiae suae congregationem per caros nostros, qui modo baptizati sunt. Petamus ergo de Domini misericordia ut baptismum sanctum, quod acceperunt, illibatum, inviolatum, et immaculatum perferant ante tribunal Christi.]

[Miss. Bobiense.
Muratori, ii.
852.]

DOMINE Deus Omnipotens, famulos Tuos, quos jussisti renasci ex aqua et Spiritu Sancto; con-

[Miss. Bobiense.
Muratori, ii.
852.]

THE THANKSGIVING.

The old office of Baptism, and that of 1549, concluded with the ceremonies which supplemented the baptism itself, and which were discontinued in 1552; except that it was always the practice

reign of our late dread Sovereign, continually defend and use the same. This resolution and practice of our Church hath been allowed and approved by the censure upon the Communion Book in King Edward the Sixth his days, and by the harmony of Confessions of later years: because indeed the use of this Sign in Baptism was ever accompanied here with such sufficient cautions and exceptions against all Popish superstition and error, as in the like cases are either fit or convenient.

First, the Church of England, since the abolishing of Popery, hath ever held and taught, and so doth hold and teach still, that the Sign of the Cross used in Baptism is no part of the substance of that Sacrament: for when the minister, dipping the infant in water, or laying water upon the face of it, (as the manner also is,) hath pronounced these words, *I baptize thee in the name of the Father, and of the Son, and of the Holy Ghost*, the infant is fully and perfectly baptized. So as the Sign of the Cross being afterwards used, doth neither add any thing to the virtue and perfection of Baptism, nor being omitted, doth detract any thing from the effect and substance of it.

Secondly, it is apparent in the Communion Book, that the infant baptized is, by virtue of Baptism, before it be signed with the Sign of the Cross, received into the congregation of Christ's flock, as a perfect member thereof, and not by any power ascribed unto the Sign of the Cross. So that for the very remembrance of the Cross, which is very precious to all them that rightly believe in Jesus Christ, and in the other respects mentioned, the Church of England hath retained still the Sign of it in Baptism; following therein the primitive and apostolical Churches, and accounting it a lawful outward ceremony and honourable badge, whereby the infant is dedicated to the Service of Him that died upon the Cross, as by the words used in the Book of Common Prayer it may appear.

Lastly, the use of the Sign of the Cross in Baptism being thus purged from all Popish superstition and error, and reduced in the Church of England to the primary institution of it, upon those true rules of doctrine concerning things indifferent, which are consonant to the Word of God, and the judgment of all the ancient Fathers, we hold it the part of every private man, both minister and other, reverently to retain the true use of it prescribed by public authority: considering that things of themselves indifferent do in some sort alter their natures, when they are either commanded or forbidden by a lawful magistrate; and may not be omitted at every man's pleasure, contrary to the law, when they be commanded, nor used when they are prohibited.

of the Church of England for the Priest to give a charge to the godfathers and godmothers respecting the future life of the child. But from the above address and prayer taken out of an ancient Italian Missal, written before A.D. 1100, it would appear that the revisionists of 1552 had a precedent for their innovation, though not perhaps exactly that here printed. The use of the Lord's Prayer in this place is, at least, analogous with the custom of the Primitive Church, in which the newly baptized were permitted and enjoined to say it for the first time immediately they had become Christians by Baptism¹.

The address which is placed as a preface to the Lord's Prayer shows that it and the Collect which follows are to be used (1) as an act of thanksgiving for the regeneration of the child by Baptism, and (2) as a prayer for the child's final perseverance in the way of salvation in which it has now been placed; and thus these few words give a key to the doctrine of the Church respecting the condition of the baptized. It is also to be observed, that the use of the Lord's Prayer immediately after Baptism is an act of thanksgiving similar to that comprehended in its use immediately after Communion; and when the Church bids us "with one accord to make our prayers" to God in the very words of our Blessed Lord, it is with the obvious intention of making that prayer the central point of devotional expression and devotional unity; a prayer as capable of expressing with one accord the highest praise and thanksgiving, as it is of expressing the deepest penitence and humiliation².

Of the Collect which follows it need only be remarked that it shows an unhesitating faith in the effects of Holy Baptism; and, also, an unhesitating conviction that without final perseverance on the part of those who have been baptized and have afterwards come to years of discrimination between good and evil, there is no hope of the attainment of that everlasting kingdom of which their regeneration has made them heirs.

At the revision of 1661 the Presbyterians objected to this Act

¹ Apost. Const., vii. 44, 45.

² See note on the Lord's Prayer, p. 6.

1 Cor. xii. 12, 13.
Eph. i. 22, 23.
Rom. vi. 11—13.
1 Pet. ii. 24.
Rom. vi. 4—7.
Col. iii. 1—5.
8—15.
Heb. xi. 39, 40.
xii. 22—24.
1 Thess. iv. 14, 19.
Luke xii. 32.
1 Pet. i. 3—5.

infant with thy holy Spirit, to receive *him* for thine own *child* by adoption, and to incorporate *him* into thy holy Church. And humbly we beseech thee to grant, that *he*, being dead unto sin, and living unto righteousness, and being buried with Christ in his death, may crucify the old man, and utterly abolish the whole body of sin; and that, as *he is* made *partaker* of the death of thy Son, *he* may also be *partaker* of his resurrection; so that finally, with the residue of thy holy Church, *he* may be an *inheritor* of thine everlasting kingdom; through Christ our Lord. *Amen.*

Then, all standing up, the Priest shall say to the Godfathers and Godmothers this Exhortation following.

Deut. xxix. 12—15. xxxii. 46, 47. xxxi. 12, 13.
Gen. xviii. 19.
Isa. xxxviii. 19.
Eph. vi. 4.
Eccl. v. 4.
Neh. viii. 1—8.
Ps. lxxviii. 5—7.
Matt. xxviii. 19, 20.
Luke xi. 7—4.
Matt. xix. 16, 17.
1 Cor. xiv. 2, 9, 11.
Prov. xxix. 6.
2 Tim. iii. 14, 15.
2 Pet. i. 13.
Heb. x. 23.
1 Pet. ii. 21.
Rom. vi. 3—6. 11.
Col. iii. 5, 8.
2 Pet. i. 3—7, 8—13.

FORASMUCH as *this child* hath promised by you *his* sureties to renounce the devil and all his works, to believe in God, and to serve him; ye must remember, that it is your parts and duties to see that *this infant* be taught, so soon as *he* shall be able to learn, what a solemn vow, promise, and profession, *he hath* here made by you. And that *he* may know these things the better, ye shall call upon *him* to hear Sermons, and chiefly ye shall provide, that *he* may learn the Creed, the Lord's Prayer, and the ten Commandments, in the vulgar tongue, and all other things which a Christian ought to know and believe to his soul's

serva in eis baptismum sanctum quod acceperunt, et in nominis Tui sanctificationem perficere dignare, ut proficiat in illos gratia tua semper, et quod te ante donante susceperunt, vitæ suæ integritate custodiant.]

I COMAUNDE ow godfadre and godmodre, on holy chirche bihalve, that ye chargen the fadur and the modur of this child, that they kepe this child in to the age of seuen yere, that hit beo from fier and water, and from alle other mischeues and periles that myȝten to him byfalle, throuȝ miskepinge, and also that ye or they techen his ryȝte bileue, hure pater noster, and hure Ave Maria, and hure Credo, or do him to beo tauȝte: and also that ye wasthe youre hondeȝ or ye gon out of Chirche: and also that hit beo confermed the next tyme that the byssop cometh to contre: and al this doeth in peyne of corsynge.

Salisbury and York Use. [Also in form of Latin Rubric.]

of Thanksgiving after Baptism,—“We cannot in faith say that every child that is baptized is ‘regenerated by God’s Holy Spirit;’ at least, it is a disputable point, and therefore we desire it to be otherwise expressed.” To this the Bishops replied as follows,—having previously referred to John iii. and Acts iii. 3, for proof that “Baptism is our spiritual regeneration,” and that by it “is received remission of sins,”—“Seeing that God’s Sacraments have their effects, where the receiver doth not ‘ponere obicem,’ put any bar against them (which children cannot do); we may say in faith of every child that is baptized, that it is regenerated by God’s Holy Spirit; and the denial of it tends to anabaptism, and the contempt of this holy sacrament, as nothing worthy, nor material whether it be administered to children or no.” Although this objection and its answer are contained in few words, they represent the substance of a long controversy, and the decision of the Church of England; a decision deliberately expressed, and in the most solemn way, by words spoken to Almighty God, in this prayer.

Forasmuch as this child hath promised] Some form of Ex-

hortation to the Sponsors is directed in all the ancient Baptismal Offices of the Church of England, sometimes in a Latin rubric stating the substance of what the Priest was to say, and others in the vernacular of the day. The above is found in a York Manual belonging to York Minster Library, and is also in a MS. Manual bought A.D. 1404-14, for the Chapel of South Charford, Breamore, near Salisbury. [Mus. Brit. Bibl. Reg. MS. 2 A. xxi.] The present exhortation restricts the responsibility of Sponsors to the spiritual oversight of their godchildren; but even this responsibility is practically in abeyance while the parents are living, since to them is assigned, in the first place, the duty of bringing up in a Christian manner the children whom God’s Providence has given them.

Bishop Cosin erased from this exhortation the words, “call upon them to hear Sermons, and chiefly ye shall,” and substituted in a later part, “ye shall call upon them at due time hereafter to frequent the Divine Service, and to hear Sermons in the Church, putting them in remembrance that” Baptism doth represent, &c. The charge respecting Confirmation was also formed by him out of the former rubric, by which the same thing was enjoined.

¹ Cardw. Conf., p. 356.

health; and that *this child* may be virtuously brought up to lead a godly and a Christian life; remembering always, that baptism doth represent unto us our profession, which is, to follow the example of our Saviour Christ, and to be made like unto him; that, as he died, and rose again for us, so should we, who are^e baptized, die from sin, and rise again unto righteousness; continually mortifying all our evil and corrupt affections, and daily proceeding in all virtue and godliness of living.

¶ *Then shall he add and say,*

Acts viii. 14—17.
xiv. 21, 22.

YE are to take care that *this child* be brought to the Bishop to be confirmed by him, so soon as *he* can say the Creed, the Lord's Prayer, and the ten Commandments, in the vulgar tongue, and be further instructed in the Church-Catechism set forth for that purpose.

Matt. xviii. 14.
18, 19.
Gal. vi. 14.
Rev. xiv. 1.

It is certain, by God's Word, that Children which are baptized, dying before they commit actual sin, are undoubtedly saved.

To take away all scruple concerning the use of the sign of the Cross in Baptism; the true explication thereof, and the just reasons for the retaining of it, may be seen in the xxxth Canon, first published in the year MDCIV.

[This exhortation varies in its phraseology, but is always the same in substance.]

INFANTS, Innocents, and Children by the sacrament of baptism do also obtain remission of their sins, and be made thereby the very sons and children of God. Insomuch as infants, dying in their infancy, shall undoubtedly be saved thereby, and else not.

Articles to establish Christian quietness, 1536
Wilkins' Conc., iii. 818.

It is certain, by God's Word] This Rubric is, in part, a reproduction of words which appeared first in "Articles to establish Christian quietness," put forth by the authority of Henry VIII. in 1536; afterwards in the "Institution of a Christian Man," which was printed in the following year; and, thirdly, in the Rubric before the Confirmation Service. When introduced into the latter Rubric, the words "and else not" were dropped, and the object of their introduction there was to show, that Confirmation was not essential to the salvation of baptized Infants.

Neither in this Rubric, nor in any other formulary of the Church of England, is any decision given as to the state of infants

dying without Baptism. Bishop Bethell says [Regeneration in Baptism, p. xiv], that the common opinion of the ancient Christians was, that they are not saved: and as our Lord has given us such plain words in John iii. 5, this seems a reasonable opinion. But this opinion does not involve any cruel idea of pain or suffering for little ones so deprived of the Sacrament of new birth by no fault of their own. It rather supposes them to be as if they had never been, when they might, through the care and love of their parents, have been reckoned among the number of those "in whom is no guile," and "who follow the Lamb whithersoever He goeth."

THE MINISTRATION OF
PRIVATE BAPTISM OF CHILDREN
IN HOUSES.

[Most of the references in this and the following Service are in addition to those on the same subjects in the former Service.]

¶ *The Curates of every Parish shall often admonish the people, that they defer not the Baptism of their children longer than the first or second Sunday next after their birth, or other Holy-day falling between, unless upon a great and reasonable cause, to be approved by the Curate.*

¶ *And also they shall warn them, that without like great cause and necessity they procure not their children to be baptized at home in their houses. But when need shall compel them so to do, then Baptism shall be administered on this fashion.*

¶ *First, let the Minister of the Parish (or in his absence, any other lawful Minister that can be procured) with them that are present call upon God, and say the Lord's Prayer, and so many of the Collects appointed to be said before in the Form of Publick Baptism, as the time and present exigence will suffer. And then, the Child being named by some one that is present, the Minister shall pour Water upon it, saying these words;*

[See references in the Service for Publick Baptism.]

N I baptize thee In the Name of
the Father, and of the Son,
and of the Holy Ghost. Amen.

¶ *Non licet laico vel mulieri aliquem baptizare, Salisbury Ueni nisi in articulo necessitatis.*

¶ *Notandum est quod quilibet sacerdos parochialis debet parochianis suis formam baptizandi in aqua pura . . . frequenter in diebus dominicis exponere, ut si necessitas emergat sciant parvulos in forma ecclesie baptizare, proferendo formam verborum baptismi in lingua materna . . . sic dicendo:*

I CRISTENE thee *N.* in the name
of the Fadir, and of the Sone, and
of the Holy Gost. Amen.

PRIVATE BAPTISM OF INFANTS.

The Baptism of Infants who were in extreme danger was provided for by certain Rubrics at the end of the Office in the ancient Manuals of the Church of England, and these Rubrics made no mention of any prayer being used, or any other words than those essential to Baptism. These Rubrics form the foundation of our present Office for Private Baptism. In the first Prayer Book, that of 1549, the person baptizing was directed to "call upon God for His grace, and say the Lord's Prayer, if the time suffice:" the use of the Lord's Prayer with that special intention being doubtless what was meant, and not any extempore prayer. But in 1661, Bishop Cosin suggested the substitution of the words "call upon God, and say the Lord's Prayer, and so many of the Collects appointed," &c. Probably great latitude had been introduced under a misinterpretation of the former Rubric, and the alteration was intended to suppress the use of extempore prayer in Private Baptisms by giving an

authorized form to be used. At the same time the spirit of the old Rubric was retained in the words, "as the time and present exigence will suffer," showing that the prayers were not to be considered as an essential part of Baptism, and that if the child is supposed to be dying rapidly, it is to be baptized at once. The Collect of Thanksgiving was also introduced from the public Service. Various attempts had been made to alter the rules of the Church, so as entirely to exclude Baptism by lay persons, even in case of extreme emergency, but these attempts were so contrary to the spirit of the ancient Church that they were never allowed to prevail¹, beyond the extent of so modifying the Rubric as effectually to discourage lay Baptism when there was no necessity for it.

In addition to the Rubrics of this Office, there is also a special law of the Church on the subject of Private Baptism, the definite

¹ See Cardw. Synodalia, i. 135, for a proposed Canon on the subject, and the Introduction to the Baptismal Offices

¶ *Then, all kneeling down, the Minister shall give thanks unto God, and say,*

WE yield thee hearty thanks, most merciful Father, that it hath pleased thee to regenerate *this Infant* with thy holy Spirit, to receive *him* for thine own *child* by adoption, and to incorporate *him* into thy holy Church. And we humbly beseech thee to grant, that as *he* is now made *partaker* of the death of thy Son, so *he* may be also of his resurrection; And that finally, with the residue of thy Saints, *he* may inherit thine everlasting kingdom; through the same thy Son Jesus Christ our Lord. *Amen.*

¶ *And let them not doubt, but that the child so baptized is lawfully and sufficiently baptized, and ought not to be baptized again. Yet nevertheless, if the child, which is after this sort baptized, do afterward live, it is expedient that it be brought into the Church, to the intent that, if the Minister of the same Parish did himself baptize that child, the Congregation may be certified of the true Form of Baptism, by him privately before used: In which case he shall say thus,*

1 Cor. xiv. 40.

I CERTIFY you, that according to the due and prescribed Order of the Church, *at such a time, and at such a place,* before divers witnesses I baptized this Child.

¶ *Et si puer fuerit baptizatus secundum illam formam, caveat sibi unusquisque ne iterum eundem baptizet: sed si hujusmodi parvuli convalescant, deferantur ad ecclesiam et dicantur super eos exorcismi et catechismi cum unctionibus et omnibus aliis supradictis præter immersionem aquæ et formam baptismi, quæ omnino sunt omittenda, videlicet: Quid petis: et ab hinc usque ad illum locum quo Sacerdos debeat parvulum chrismate linire.*

words of which make it a good guide both for Clergy and Laity. It is as follows:—

“Canon 69.

“*Ministers not to defer Christening, if the Child be in danger.*

“If any Minister, being duly, without any manner of collusion, informed of the weakness and danger of death of any infant unbaptized in his parish, and thereupon desired to go or come to the place where the said infant remaineth, to baptize the same, shall either wilfully refuse so to do, or of purpose, or of gross negligence, shall so defer the time, as, when he might conveniently have resorted to the place, and have baptized the said infant, it dieth, through such his default, unbaptized; the said Minister shall be suspended for three months; and before his restitution shall acknowledge his fault, and promise before his Ordinary, that he will not wittingly incur the like again. Provided, that where there is a Curate, or a Substitute, this Constitution shall not extend to the Parson or Vicar himself, but to the Curate or Substitute present¹.”

It cannot be said that there is never any “collusion” in this matter, and the clergyman is therefore bound to make strict inquiry as to the condition of the child whose baptism in private is required. Objection to the rite being administered during time of Divine Service, the expense of a “christening feast,”

¹ The last words, of course, refer to a non-resident Parson or Vicar, “Curate” being used in the comprehensive sense of the clergyman in actual charge of the parish.

desire to make sure of “burial money,” (which is lost when children die unbaptized,) are all reasons that have come within the writer’s experience: and, except in cases where there is manifest danger of death, it is best both for the Clergy and the Laity that a medical certificate should be provided, stating that there is weakness or disease which renders the infant incapable of being brought to Church for public baptism without risk.

The remaining part of what is printed under the heading, “The Ministration of Private Baptism of Children in Houses,” is an adaptation to the case of such children of that part of the Office for Baptism which is not used in private.

The object of bringing a convalescent child who has been clinically baptized to Church, is twofold. (1) First, that a solemn public recognition may be made of the child’s regenerated condition by the Priest “receiving him as one of the flock of true Christian people” in the face of the Church: and (2), secondly, that the child, by its sureties, may make those solemn engagements of the Baptismal vow which were omitted when it was supposed that the infant would not “come of age” to be capable of fulfilling them.

The form in which the certification is to be given when it is to be made by the clergyman who has himself baptized the child was not defined until the revision of 1661. In Bishop Cosin’s Durham Book he has written the following proposed form: “. . . *in which case he shall say thus: I certify you that, according to the due and prescribed Order of the Church, in case of necessity, at such a time, and in such a place, and before divers witnesses, I administered private Baptism to this child, who being born in original*

¶ *But if the child were baptized by any other lawful Minister, then the Minister of the Parish where the child was born or christened, shall examine and try whether the child be lawfully baptized, or no. In which case, if those that bring any child to the Church do answer, that the same child is already baptized, then shall the Minister examine them further, saying,*

BY whom was this child baptized?

Who was present when this child was baptized?

Acts xix. 3-5.

Because some things essential to this Sacrament may happen to be omitted through fear or haste, in such times of extremity; therefore I demand further of you,

With what matter was this child baptized?

With what words was this child baptized?

¶ *And if the Minister shall find by the answers of such as bring the child, that all things were done as they ought to be; then shall not he christen the child again, but shall receive him as one of the flock of true Christian people, saying thus,*

¶ *Et ideo si laicus baptizaverit puerum, antequam deferatur ad ecclesiam, interroget Sacerdos diligenter quid dixerit, et quid fecerit:*

et si invenerit laicum discrete et debito modo baptizasse, et formam verborum baptismi ut supra in suo idiomate integre protulisse, approbet factum, et non rebaptizet eum . . .

Eph. ii. 3-5.
v. 26.
Tit. iii. 5-7.
Matt. xviii. 1-14.

I CERTIFY you, that in this case all is well done, and according unto due order, concerning the baptizing of this child; who being born in original sin, and in the wrath of God, is now, by the laver of Regeneration in Baptism, received into the number of the children of God, and heirs of everlasting life: for our Lord Jesus Christ doth not deny his grace and mercy unto such Infants, but most lovingly doth call them unto him, as the holy Gospel doth witness to our comfort on this wise.

[Mark x. 13-16.]

¶ *After the Gospel is read, the Minister shall make this brief Exhortation upon the words of the Gospel.*

Mark ix. 23, 24.
Matt. xxi. 21, 22.
John xvii. 2, 3.
Matt. xviii. 14.
xix. 13-15.
Ps. ciii. 1-4.
Luke xi. 1-4.

BELOVED, ye hear in this Gospel the words of our Saviour Christ, that he commanded the children to be brought unto him; how he blamed

those that would have kept them from him; how he exhorted all men to follow their innocency. Ye perceive how by his outward gesture and deed he declared his good will toward them; for he embraced them in his arms, he laid his hands upon them, and blessed them. Doubt ye not therefore, but earnestly believe, that he hath likewise favourably received this present infant; that he hath embraced *him* with the arms of his mercy; and (as he hath promised in his holy Word) will give unto *him* the blessing of eternal life; and make *him* partaker of his everlasting kingdom. Wherefore, we being thus persuaded of the good will of our heavenly Father, declared by his Son Jesus Christ, towards this infant, let us faithfully and devoutly give thanks unto him, and say the prayer which the Lord himself taught us.

sin, &c. *ut infra*." From this it would appear, that the whole of the following part of the form, as afterwards printed, was intended by him to have been used in every case. The internal evidence of the Office seems to indicate such an intention also, and probably the omission is a clerical error, which has arisen from Cosin not writing the whole at length in his MS. revision.

Cosin also transferred the Lord's Prayer from the place which it here occupies, and which is that of the old Office, to the same place as it occupies in the ordinary service for Public Baptism: but although his alteration is left as he wrote it, while erasures are on either side, it was not printed, and the two forms of the Office do not agree.

OUR Father, which art in heaven, Hallowed be thy Name: Thy kingdom come. Thy will be done in earth, As it is in heaven. Give us this day our daily bread. And forgive us our trespasses, As we forgive them that trespass against us. And lead us not into temptation; But deliver us from evil. Amen.

Ps. xli. 18.
1 Pet. ii. 9.
Eph. i. 15—19.
Acts ii. 38, 39.
2 Thess. ii. 13, 14.
Gal. iii. 29.
Col. ii. 6, 7.
2 Pet. iii. 18.

ALmighty and everlasting God, heavenly Father, we give thee humble thanks, that thou hast vouchsafed to call us to the knowledge of thy grace, and faith in thee: Increase this knowledge, and confirm this faith in us evermore. Give thy holy Spirit to *this infant*, that *he*, being born again, and being made *an heir* of everlasting salvation, through our Lord Jesus Christ, may continue thy *servant*, and attain thy promise; through the same our Lord Jesus Christ thy Son, who liveth and reigneth with thee and the Holy Spirit, now and for ever. Amen.

¶ *Then shall the Priest demand the Name of the child; which being by the Godfathers and Godmothers pronounced, the Minister shall say,*

1 John iii. 8, 9.
v. 19.
Gal. v. 16—21.

DOST thou, in the name of this Child, renounce the devil and all his works, the vain pomp and glory of this world, with all covetous desires of the same, and the carnal desires of the flesh, so that thou wilt not follow, nor be led by them?

Answer.

I renounce them all.

Minister.

DOST thou believe in God the Father Almighty, Maker of heaven and earth?

And in Jesus Christ his only-begotten Son our Lord? And that he was conceived by the Holy Ghost; born of the Virgin Mary; that he suffered under Pontius Pilate, was crucified, dead, and buried; that he

went down into hell, and also did rise again the third day; that he ascended into heaven, and sitteth at the right hand of God the Father Almighty; and from thence shall come again at the end of the world, to judge the quick and the dead?

And dost thou believe in the Holy Ghost; the holy Catholick Church; the Communion of Saints; the Remission of sins; the Resurrection of the flesh; and everlasting life after death?

Answer.

All this I stedfastly believe.

Minister.

WILT thou then obediently keep God's holy will and commandments, and walk in the same all the days of thy life?

Answer.

I will.

¶ *Then the Priest shall say,*

WE receive this child into the congregation of Christ's flock, and do + sign *him* with the sign of the Cross, in token that hereafter *he* shall not be ashamed to confess the faith of Christ crucified, and manfully to fight under his banner, against sin, the world, and the devil; and to continue Christ's faithful soldier and servant unto *his* life's end. Amen.

¶ *Then shall the Priest say,*

SEEING now, dearly beloved brethren, that *this child* is by Baptism regenerate, and grafted into the body of Christ's Church, let us give thanks unto Almighty God for these benefits; and with one accord make our prayers unto him, that *this child* may lead the rest of *his* life according to this beginning.

¶ *Then shall the Priest say,*

WE yield thee hearty thanks, most merciful Father, that it hath pleased thee to regenerate *this Infant* with thy holy Spirit, to receive

At the end of the Exhortation in the Prayer Books, as they stood before 1661, there was a Rubric, "And so forth, as in Public Baptism." This Rubric was erased by Cosin, and he substituted, "Then shall he add and say, Furthermore, I require you to take care *ut supra* in public Baptism." This Supplementary charge is not printed in the Sealed books, yet it seems

clear that its omission was a clerical error, and that it ought to be inserted by the clergyman when he uses the Office.

There is, in fact, a certain want of exact consistency about the use of this Office (and the same is observable in the use of the unreformed Office "*ad faciendum Catechumenum*") over a baptized child. It is also impossible to follow it exactly if an attempt is

Phil. iii. 10, 11.
Acts xv. 16, 17.
xx. 32.
Heb. iii. 14. xii.
22—24.

him for thine own *Child* by adoption, and to incorporate him into thy holy Church. And humbly we beseech thee to grant, that *he*, being dead unto sin and living unto righteousness, and being buried with Christ in his death, may crucify the old man, and utterly abolish the whole body of sin; and that, as *he* is made partaker of the death of thy Son, *he* may also be partaker of his resurrection; so that finally, with the residue of thy holy Church, *he* may be an inheritor of thine everlasting kingdom; through Jesus Christ our Lord. Amen.

¶ Then, all standing up, the Priest shall say to the Godfathers and Godmothers this Exhortation following.

Ps. l. 14.
Gal. iv. 1, 2.
Deut. iv. 9, 10.
vi. 7.
Ps. xxxiy. 11.
Rom. x. 17.
Luke ii. 41, 42.
Heb. xi. 6.
Luke xviii. 1.
John xiv. 10, 14.
Isa. lv. 3.

FORASMUCH as this *Child* hath promised by you his surties to renounce the devil and all his works; to believe in God, and to serve him; ye must remember, that it is your parts and duties to see that *this infant*

¶ But if they which bring the Infant to the Church do make such uncertain answers to the Priest's questions, as that it cannot appear that the *Child* was baptized with Water, In the Name of the Father, and of the Son, and of the Holy Ghost, (which are essential parts of Baptism,) then let the Priest baptize it in the form before appointed for Publick Baptism of Infants; saving that at the dipping of the *Child* in the Font, he shall use this form of words.

IF thou art not already baptized, I N. I baptize thee In the Name of the Father, and of the Son, and of the Holy Ghost. Amen.

be taught, so soon as *he* shall be able to learn, what a solemn vow, promise, and profession, *he hath* here made by you. And that *he* may know these things the better, ye shall call upon *him* to hear Sermons; and chiefly ye shall provide, that *he* may learn the Creed, the Lord's Prayer, and the ten Commandments, in the vulgar tongue, and all other things which a Christian ought to know and believe to his soul's health; and that *this child* may be virtuously brought up to lead a godly and a Christian life; remembering always, that Baptism doth represent unto us our profession; which is, to follow the example of our Saviour Christ and to be made like unto him that, as he died, and rose again for us, so should we, who are baptized, die from sin and rise again unto righteousness; continually mortifying all our evil and corrupt affections, and daily proceeding in all virtue and godliness of living.

Eph. vi. 4.
2 Tim. ii. 19, 22.
Tit. iii. 4—8.
John xiv. 15—17.
Phil. ii. 5.
1 Cor. xv. 8, 4, 49.
Heb. vi. 1—3.
2 Cor. xiii. 7, 9, 11.
2 Cor. vii. 1.

... Si vero dubitet rationabiliter Sacerdos utrum infans ad baptizandum sibi oblatus prius in forma debita fuerit baptizatus vel non, debet omnia perficere cum eo sicut cum alio quem constat sibi non baptizatum, praterquam quod verba sacramentalia essentialia proferre debeat sub conditione, hoc modo dicendo:

N. si baptizatus es, ego non rebaptizo te: sed si nondum baptizatus es, ego baptizo te, in nomine Patris, et Filii, et Spiritus Sancti. Amen. Sub aspersione vel immersione ut supra.

made to amalgamate it with the Office for Public Baptism. It was probably intended to be used at the font, but no water should be placed in the latter.

CONDITIONAL BAPTISM.

The earliest mention of conditional Baptism is in the statutes of St. Boniface, Archbishop of Mentz about A.D. 745. His words as given by Martene [de Antiq., rit. i., l. xvi. 10] are, "Si de aliquibus dubium sit, utrum sint baptizati, absque ullo scrupulo baptizentur; his tamen verbis premissis: Non te rebaptizo, sed si nondum es baptizatus, etc." It is not probable that Boniface would originate this form, nor is it likely that the whole Western Church would so exactly have adopted any form

originated by him; we may therefore reasonably conclude that his words represent the established usage of the ancient and settled Churches of Europe when he wrote, and that the charity of the Church had always provided such a form.

Conditional Baptism ought not to be administered hastily as a means of escaping from a difficulty. The principle of the Church is clear and unhesitating (as is shown in the rubric above) that if water and the words of Institution have been used they have constituted a true Baptism, the iteration of which would be sinful in the baptizer, and at the same time useless to the baptized. But, after careful inquiry, doubts may often be felt as to the due use of the essentials of Baptism, and in such a case the conditional form should certainly be adopted, for the sake of the child.

THE MINISTRATION OF
BAPTISM TO SUCH AS ARE OF RIPER YEARS,
AND ABLE TO ANSWER FOR THEMSELVES.

[The References on Infant Baptism are generally applicable here also.]

¶ *When any such persons as are of riper years are to be baptized, timely notice shall be given to the Bishop, or whom he shall appoint for that purpose, a week before at the least, by the Parents, or some other discreet persons; that so due care may be taken for their examination, whether they be sufficiently instructed in the principles of the Christian Religion; and that they may be exhorted to prepare themselves with prayers and fasting for the receiving of this holy Sacrament.*

¶ *And if they shall be found fit, then the God-fathers and Godmothers (the people being assembled upon the Sunday or Holy-day appointed) shall be ready to present them at the Font immediately after the second Lesson, either at Morning or Evening Prayer, as the Curate in his discretion shall think fit.*

¶ *And standing there, the Priest shall ask whether any of the persons here presented be baptized or no: If they shall answer, No; then shall the Priest say thus,*

*John iii. 6.
Rom. viii. 5—8.
iii. 10—19, 23.
Gal. iii. 22.*

DEARLY beloved, forasmuch as all men are conceived and born in sin, (and that which is born of the flesh is flesh,) and they that are in the flesh cannot please God, but live in sin, committing many actual transgressions; and that our Saviour Christ saith, None can enter into the kingdom of God, except he be regenerate and born anew of Water and of the holy Ghost; I beseech you to call upon God the Father, through our Lord Jesus Christ, that of his bounte-

ous goodness he will grant to *these persons* that which by nature *they* cannot have, that *they* may be baptized with water and the holy Ghost, and received into Christ's holy Church, and be made lively members of the same.

¶ *Then shall the Priest say,*

Let us pray.

(¶ *And here all the Congregation shall kneel.*)

ALMIGHTY and everlasting God, who of thy great mercy didst save Noah and his family in the ark from perishing by water; and also didst safely lead the children of Israel thy people through the Red Sea, figuring thereby thy holy Baptism; and by the Baptism of thy well-beloved Son Jesus Christ, in the river Jordan, didst sanctify the element of water to the mystical washing away of sin; We beseech thee, for thine infinite mercies, that thou wilt mercifully look upon *these thy servants*; wash *them* and sanctify *them* with the holy Ghost, that *they* being delivered from thy wrath may be received into the ark of Christ's Church; and being stedfast in faith, joyful through hope, and rooted in charity, may so pass the waves of this troublesome world, that finally *they* may come to the land of everlast-

*2 Pét. ii. 4, 5, 9.
Gen. vi., vii., viii.
Ex. xiv.
Ps. cxv. 9.
Col. ii. 11, 12.
1 John v. 6.
Ps. cxlv. 9.
1 Pét. i. 2.
Rom. i. 13.
Gen. vii. 1.
Heb. iii. 14, 6.
vi. 19.
Eph. iii. 17.
Acts xiv. 21, 22.*

THE BAPTISM OF ADULTS.

In that Preface to the Prayer Book which was written by Bishop Sanderson in 1661, it is stated that among other alterations and additions it was thought expedient to add "an Office for the Baptism of such as are of riper years; which, although

not so necessary when the former Book was compiled, yet by the growth of Anabaptism, through the licentiousness of the late times crept in amongst us, is now become necessary, and may be always useful for the baptizing of Natives in our Plantations, and others converted to the Faith." It is probable that this was suggested by Bishop Cosin, for at the end of the Office for Private

ing life, there to reign with thee world without end; through Jesus Christ our Lord. *Amen.*

1 Tim. i. 17.
Ps. cxlvi. 7—9.
cxiv. 8.
John iii. 36.
vi. 39, 40.
James v. 16.
Acts xxii. 16.
Col. ii. 12, 13.
Luke xi. 9—12.
John xiii. 8.
Gal. iii. 27, 28.
1 John i. 7.
1 Pet. v. 10.
Rom. vi. 25.

ALmighty and immortal God, the aid of all that need, the helper of all that flee to thee for succour, the life of them that believe, and the resurrection of the dead; We call upon thee for *these persons*, that *they*, coming to thy holy Baptism, may receive remission of *their* sins by spiritual regeneration. Receive *them*, O Lord, as thou hast promised by thy well-beloved Son, saying, Ask, and ye shall receive; seek, and ye shall find; knock, and it shall be opened unto you; So give now unto us that ask; let us that seek find; open the gate unto us that knock; that *these persons* may enjoy the everlasting benediction of thy heavenly washing, and may come to the eternal kingdom which thou hast promised by Christ our Lord. *Amen.*

¶ *Then shall the people stand up, and the Priest shall say,*

Hear the words of the Gospel, written by Saint John, in the third Chapter, beginning at the first verse.

THERE was a man of the Pharisees, named Nicodemus, a ruler of the Jews. The same came to Jesus by night, and said unto him, Rabbi, we know that thou art a teacher come from God; for no man can do these miracles that thou doest, except God be with him. Jesus answered and said unto him, Verily, verily I say unto thee, Except a man be born again, he cannot see the kingdom of God. Nicodemus saith unto him, How can a man be born when he is old? Can he enter the second time into his mother's womb, and be born?

Jesus answered, Verily, verily I say unto thee, Except a man be born of water and of the Spirit, he cannot enter into the kingdom of God. That which is born of the flesh is flesh; and that which is born of the Spirit is spirit. Marvel not that I said unto thee, Ye must be born again. The wind bloweth where it listeth, and thou hearst the sound thereof; but canst not tell whence it cometh, and whither it goeth: so is every one that is born of the Spirit.

¶ *After which he shall say this exhortation following.*

BELOVED, ye hear in this Gospel John iii. 3—5. the express words of our Saviour Christ, that except a man be born of water and of the Spirit, he cannot enter into the kingdom of God. Whereby ye may perceive the great necessity of this Sacrament, where it may be had. Likewise, immediately before his ascension into heaven, (as we read in the last Chapter of Saint Mark's Gospel,) Mark xvi. 16. he gave command to his disciples, saying, Go ye into all the world, and preach the Gospel to every creature. He that believeth and is baptized shall be saved; but he that believeth not shall be damned. Which also sheweth unto us the great benefit we reap thereby. For which cause Saint Peter the Apostle, when upon his first preaching of the Gospel many were pricked at the heart, and said to him and the Acts ii. 38—40. rest of the Apostles, Men and brethren, what shall we do? replied and said unto them, Repent and be baptized every one of you for the remission of sins, and ye shall receive the gift of the Holy Ghost. For the promise is to you and your children, and to all that are afar off, even as many as the Lord our God shall call. And with

Baptism in his Durham Book, he has written, "*Print in a new leaf, The Ministration of Publick Baptism to such as are of perfect age, or come to the years of discretion, and are able to render an account of their faith, and undertake for themselves;*" all after "*discretion*" being subsequently erased. The Office was, however, framed under the direction of a Committee of Convocation, consisting of the following Bishops and Clergy:—

Henchman, Bishop of Salisbury.
Laney, " Peterborough.
Griffith, " St. Asaph.

Earl, Dean of Westminster.
Oliver, " Worcester.
Sparrow, Archdeacon of Sudbury.
Creed, " Wilts.
Heywood,

Gunning, afterwards Bishop of Chichester and of Ely.

These met at the Savoy for the purpose on May 20th, 1661, a date which shows that the review of the Prayer Book was begun six months before the final official steps towards revision were undertaken [see p. xl]. Wood, in his *Athenæ Oxoniensis*, says

many other words exhorted he them, saying, Save yourselves from this untoward generation. For (as the same Apostle testifieth in another place) even Baptism doth also now save us, (not the putting away of the filth of the flesh, but the answer of a good conscience towards God,) by the resurrection of Jesus Christ. Doubt ye not therefore, but earnestly believe, that he will favourably receive *these* present persons, truly repenting, and coming unto him by faith; that he will grant *them* remission of *their* sins, and bestow upon *them* the holy Ghost; that he will give *them* the blessing of eternal life, and make *them* partakers of his everlasting kingdom.

Wherefore we being thus persuaded of the good will of our heavenly Father towards *these* persons, declared by his Son Jesus Christ; let us faithfully and devoutly give thanks to him, and say,

ALmighty and everlasting God, heavenly Father, we give thee humble thanks, for that thou hast vouchsafed to call us to the knowledge of thy grace, and faith in thee: Increase this knowledge, and confirm this faith in us evermore. Give thy holy Spirit to *these* persons, that *they* may be born again and be made heirs of everlasting salvation, through our Lord Jesus Christ, who liveth and reigneth with thee and the Holy Spirit, now and for ever. Amen.

¶ Then the Priest shall speak to the persons to be baptized on this wise:

WELL-BELOVED, who are come hither desiring to receive holy Baptism, ye have heard how the congregation hath prayed that our Lord Jesus Christ would vouchsafe to receive you and bless you, to release you of your sins, to give you the

kingdom of heaven and everlasting life. Ye have heard also that our Lord Jesus Christ hath promised in his holy Word to grant all those things that we have prayed for; which promise he, for his part, will most surely keep and perform.

Wherefore, after this promise made by Christ, ye must also faithfully, for your part, promise in the presence of these your witnesses, and this whole congregation, that ye will renounce the devil and all his works, and constantly believe God's holy Word, and obediently keep his commandments.

¶ Then shall the Priest demand of each of the persons to be baptized, severally, these Questions following:

Question.

DOST thou renounce the devil and all his works, the vain pomp and glory of the world, with all covetous desires of the same, and the carnal desires of the flesh, so that thou wilt not follow, nor be led by them?

Answer.

I renounce them all.

Question.

DOST thou believe in God the Father Almighty, Maker of heaven and earth?

And in Jesus Christ his only-begotten Son our Lord? And that he was conceived by the Holy Ghost; born of the Virgin Mary; that he suffered under Pontius Pilate, was crucified, dead, and buried; that he went down into hell, and also did rise again the third day; that he ascended into heaven, and sitteth at the right hand of God the Father Almighty; and from thence shall come again at the end of the world, to judge the quick and the dead?

1 Pet. iii. 21.

1 Tim. ii. 8.
Acts xx. 21. viii.
36-38. x. 47.
John x. 28.
2 Pet. i. 11.

1 Tim. ii. 3, 4.
John iii. 16, 17.
1 Cor. ix. 15.

Ps. xli. 13.
Eph. i. 3. 15-19.
Col. ii. 3. iii. 10.
1 John iii. 23.
2 Thess. ii. 13, 14.
John i. 13.
Heb. v. 9.
Rev. xxii. 5.

3 John i.

Heb. vi. 16-20.
John xiv. 13, 14.
2 Cor. i. 20.
Ruth iv. 9.
Matt. xviii. 16.

1 Pet. v. 3, 9.
1 John iii. 8, 9.
v. 19.
Gal. v. 19-21.

that the Bishop of St. Asaph had the chief hand in composing this form. It received the approbation of Convocation on May 31st, 1661¹.

Two rubrics at the end of this Office furnish a rule as to the age of the persons for whom it is to be used. The first enjoins that every one baptized with it shall be confirmed and be admitted to the Holy Communion as soon as conveniently may be.

¹ Cardw. Conf., pp. 370. 374. Lathbury's Convoc., p. 283

From this it is evident that all who would be considered old enough to be confirmed if they had been baptized come within the limits of those "riper years" named in the title. The second rubric lays down the rule that the office is not to be used for those who are not yet come to years of discretion to answer for themselves, but that such shall be baptized with the office for Infant Baptism. Adult idiots ought to be baptized, but not with this Office: and perhaps that for Private Baptism is best suited to their case, if neglect of Baptism in their infancy has been added to

And dost thou believe in the Holy Ghost; the holy Catholick Church, the Communion of Saints; the Remission of sins; the Resurrection of the flesh; and everlasting life after death?

Answer.

All this I stedfastly believe.

Question.

Acts viii. 36—38.

WILT thou be baptized in this faith?

Answer.

That is my desire.

Question.

1 John ii. 3, 4, 6.

WILT thou then obediently keep God's holy will and commandments, and walk in the same all the days of thy life?

Answer.

I will endeavour so to do, God being my helper.

¶ *Then shall the Priest say,*

1 Cor. xv. 45, 22.
Eph. ii. 4—6.

O MERCIFUL God, grant that the old Adam in *these persons* may be so buried, that the new man may be raised up in *them*. *Amen.*

Rom. vi. 11.
Gal. v. 22, 23.

Grant that all carnal affections may die in *them*, and that all things belonging to the Spirit may live and grow in *them*. *Amen.*

2 Cor. xii. 9.
Eph. iii. 16, vi. 10, 11, 13.

Grant that *they* may have power and strength to have victory, and to triumph, against the devil, the world, and the flesh. *Amen.*

2 Cor. ii. 14.
1 Cor. iv. 1.
Col. i. 9, 10, 28.
iii. 24.
1 Tim. vi. 15.

Grant that *they*, being here dedicated to thee by our office and ministry, may also be endued with heavenly virtues, and everlastingly rewarded through thy mercy, O blessed Lord God, who dost live, and govern all things, world without end. *Amen.*

Zech. xiii. 1.
Eph. i. 7.
1 John i. 7.
Matt. xxviii. 18, 19.
John xvi. 23, 24.

ALMIGHTY, everliving God, whose most dearly beloved Son Jesus Christ, for the forgiveness of our

sins, did shed out of his most precious side both water and blood, and gave commandment to his disciples, that they should go teach all nations, and baptize them In the Name of the Father, the Son, and the Holy Ghost; Regard, we beseech thee, the supplications of this congregation; sanctify this water to the mystical washing away of sin; and grant that the *persons* now to be baptized therein may receive the fulness of thy grace, and ever remain in the number of thy faithful and elect children, through Jesus Christ our Lord. *Amen.*

1 John v. 14.
1 Cor. vi. 11.
Tit. iii. 5, 6.
Acts ii. 41, 42.
1 Pet. i. 2.

¶ *Then shall the Priest take each person to be baptized by the right hand, and pleying him conveniently by the Font, according to his discretion, shall ask the Godfathers and Godmothers the Name; and then shall dip him in the water, or pour water upon him, saying,*

N I baptize thee In the Name of the Father, and of the Son, and of the Holy Ghost. *Amen.*

¶ *Then shall the Priest say,*

WE receive this person into the congregation of Christ's flock; + and do sign *him* with the sign of the cross, in token that hereafter *he* shall not be ashamed to confess the faith of Christ crucified, and manfully to fight under his banner, against sin, the world, and the devil; and to continue Christ's faithful soldier and servant unto *his* life's end. *Amen.*

Luke xii. 32.
Rom. iv. 11.
1 Cor. i. 23.
Mark viii. 38.
1 John v. 4, 5.
2 Tim. iv. 7, 8.
Matt. xxiv. 13.

+ *Here the Priest shall make a cross upon the person's forehead.*

¶ *Then shall the Priest say,*

SEEING now, dearly beloved brethren, that *these persons* are regenerate, and grafted into the body of Christ's Church, let us give thanks unto Almighty God for these benefits, and with one accord make our prayers unto him, that *they* may lead the rest of *their* life according to this beginning.

2 Cor. v. 17.
1 Cor. xii. 13.
Eph. i. 22, 23.
Ps. lxxviii. 19.
Matt. xviii. 19.
2 Pet. iii. 18.

their natural misfortune. Perhaps it may be laid down as a general rule that while Confirmation is not given to young children, all under the age of twelve should be baptized as Infants, and all persons above that age with the present Office.

As this Office was framed entirely for adult persons, whether born of Christian or of Heathen parents, it necessarily recurs to those principles on which Holy Baptism was administered in the primitive times of Christianity when millions of such persons were so admitted into the Church of Christ. Thus the Can-

didate for Baptism is a Catechumen in the ancient sense; and as such is admitted to the sacrament of regeneration only by the express permission of a chief minister of the Church, and after proper instruction and examination, with the discipline of prayer and fasting. It may be observed also, that a Bishop or Priest is supposed throughout to be the minister of Adult Baptism in public; though, of course, the ordinary rules as to valid Baptism apply to extreme cases of dying persons, when no priest can be procured.

¶ *Then shall be said the Lord's Prayer, all kneeling.*

OUR Father, which art in heaven, Hallowed be thy Name. Thy kingdom come. Thy will be done in earth, As it is in heaven. Give us this day our daily bread. And forgive us our trespasses, As we forgive them that trespass against us. And lead us not into temptation; But deliver us from evil. Amen.

Col. i. 3. 6.
Phil. i. 4—6.
2 Cor. i. 3.
Acts ii. 38, 39.
xxvi. 18.
Col. ii. 6, 7.
1 Cor. xii. 7.
Acts xx. 32.
Col. i. 12—14.

WE yield thee humble thanks, O heavenly Father, that thou hast vouchsafed to call us to the knowledge of thy grace, and faith in thee: Increase this knowledge, and confirm this faith in us evermore. Give thy holy Spirit to *these persons*; that being now born again, and made *heirs* of everlasting salvation through our Lord Jesus Christ, *they* may continue thy *servants*, and attain thy promises through the same Lord Jesus Christ thy Son, who liveth and reigneth with thee in the unity of the same Holy Spirit, everlastingly. Amen.

¶ *Then, all standing up, the Priest shall use this Exhortation following; speaking to the Godfathers and Godmothers first.*

1 Tim. vi. 12, 13.
Matt. xviii. 16.
2 Pet. i. 12.
Eccl. v. 4, 5.
2 Cor. xiii. 1.
Acts xvii. 11.
1 Thess. ii. 11—13.
2 Pet. iii. 18.
Tit. ii. 12.

FORASMUCH as *these persons* have promised in your presence to renounce the devil and all his works, to believe in God, and to serve him; ye must remember, that it is your part and duty to put *them* in mind, what a solemn vow, promise, and profession *they* have now made before this congregation, and especially before you *their* chosen witnesses. And ye are

also to call upon *them*, to use all diligence to be rightly instructed in God's holy Word; that so *they* may grow in grace, and in the knowledge of our Lord Jesus Christ, and live godly, righteously, and soberly in this present world.

(¶ *And then, speaking to the new baptized persons, he shall proceed, and say,*)

AND as for you, who have now by Baptism put on Christ, it is your part and duty also, being made the *children* of God and of the light, by faith in Jesus Christ, to walk answerably to your Christian calling, and as becometh the children of light; remembering always that Baptism representeth unto us our profession; which is, to follow the example of our Saviour Christ, and to be made like unto him; that as he died, and rose again for us; so should we who are baptized, die from sin, and rise again unto righteousness, continually mortifying all our evil and corrupt affections, and daily proceeding in all virtue and godliness of living.

Gal. iii. 26, 27.
Eph. iv. 1.
Eph. v. 8.
Rom. vi. 3—6, 11.
1 John ii. 6.
2 Pet. i. 3—7.

¶ *It is expedient that every person thus baptized should be confirmed by the Bishop soon after his Baptism as conveniently may be; that so he may be admitted to the holy Communion.*

¶ *If any persons not baptized in their infancy shall be brought to be baptized before they come to years of discretion to answer for themselves; it may suffice to use the Office for Publick Baptism of Infants, or (in case of extreme danger) the Office for Private Baptism, only changing the word [Infant] for [Child or Person] as occasion requireth.*

The ritual of the Baptism of Adults differs from that of infants only in three particulars:—1. The person to be baptized answers the interrogatories himself. 2. The Priest takes him by the right hand and brings him to the font, "placing him conveniently by the Font." 3. An address to the newly baptized follows the short one which is made to the sponsors. To these it may be added, fourthly, though not directed in the rubric, that it is most reverent and seemly for the person who is being baptized to kneel during the act of Baptism. Women should also be provided with caps similar to those used at Confirmation, to be removed, of course, during the actual Baptism.

Persons who have come to years of discretion are sometimes in doubt respecting their baptism, and are anxious to be baptized with the conditional form. As a rule the Church has always

concluded that those who have been born of Christian parents have been baptized, unless the contrary can be proved. Careful inquiry should, therefore, be made whether there is really any good reason for doubt before any such question is entertained. But if, after inquiry, there still remains cause for doubt, there seems to be no reason why the conditional form should not (the Bishop consenting) be used, although no actual provision is made for it in the case of adult persons. Even although a person may have been confirmed and have received the Holy Communion, if it is afterwards discovered that he has not been baptized, the sacrament of Baptism should be administered. In such a case, reverent doubt as to the effect of the latter Sacrament in supplying the omission of the former might well lead to the use of the conditional form.

AN

INTRODUCTION TO THE CATECHISM.

THE ecclesiastical word Catechismus is derived from the Greek *κατήχησις*, and means literally an instruction by word of mouth of such a kind as to draw out a reply or echo¹. In the earliest age of the Church the word was used for that kind of instruction which was given to the catechumens or candidates for Baptism [Luke i. 4]; and from this usage it has come to mean also, in later ages, the instruction which is given to candidates for Confirmation. A similar kind of instruction among the Jews is indicated by the only incident which is recorded of our Lord's childhood, when after three days' disappearance He was found by His Mother and Joseph "sitting in the midst of the doctors, both hearing them, and asking them questions" [Luke ii. 46].

In the Primitive Church catechizing appears to have been carried on by means of what we should now call a lecture, the questions being asked rather by the persons catechized than by the person catechizing. A life-like description of such a method is contained in an epistle of St. Augustine to Deo Gratias, which is, in fact, a treatise on catechizing, and has the title "De catechizandis rudibus." It was written A.D. 400. There is also an invaluable series of Catechetical Lectures by St. Cyril of Jerusalem, delivered in that city about A.D. 347. In the previous century Origen, and before him Clemens Alexandrinus (who left a series of Catechetical Lectures entitled *Pædagogus*), and Pantænus, his predecessor, had made the catechetical school of Alexandria famous for the instruction there conveyed in the principles of Christianity; but there can be no doubt that this instruction was of a less elementary character than what is usually understood by the word catechizing.

In St. Augustine's treatise he gives a description of the manner in which a catechist is to keep alive the attention and interest of the person who is being catechized: he also sets forth the subjects of instruction, and gives two examples, one long, the other short, of the mode in which those subjects were to be taught in detail. From these it appears to have been the custom first to give a narration of the Bible History, and then to show its connexion with Christianity, afterwards setting forth the doctrines of the Creed, and the principles of Christian duty. St. Cyril's lectures also begin with an exposition of the relation which the Old Testament history bears to Christ and Christianity: they then go on to explain the principles of Baptism and the benefits to be derived from it; afterwards expound the Creed in fifteen lectures; and conclude with five on the Sacraments of Baptism and the

Lord's Supper, the latter addressed to the same set of hearers immediately after their baptism had taken place².

It will be observed that this primitive form of instruction was of a different character from that fixed question and answer which we understand in modern times by the word Catechism. This was represented by the Interrogatories which formed part of the Office for Baptism and Confirmation, and which were called by that name both in primitive and in mediæval times. Thus St. Cyril says, "Let thy feet hasten to the Catechizings, receive with earnestness the Exorcisms; for whether thou art breathed upon or exorcised, the Ordinance is to thee salvation" [Introd. Lect. 9, Oxf. transl.]. So among Archbishop Peckham's Constitutions there is one which enjoins "that children baptized by laymen or women in case of urgent necessity are not to be baptized again;" and it is added, "let the exorcisms and catechisms be used over children so baptized, in reverence to the ordinances of the Church" [Johnson's Canons, ii. 277].

When the Offices of the Church of England were translated into English, and an endeavour was being made to develop further than had hitherto been done the intelligent use of them by the laity, and also to promote generally an intellectual religion among them, a Catechism was inserted in the Office for Confirmation. This was, of course, to be learned during the period of preparation for Confirmation; but the Rubric directed that when the rite was to be administered, the Bishop, or some one appointed by him, should "appose" the persons to be confirmed by requiring them to answer such questions of this Catechism as the former should see fit. The object of this was stated to be that those who were about to be confirmed might "then themselves with their own mouth, and with their own consent, openly before the Church, ratify and confess" what their Godfathers and Godmothers had promised for them in their Baptism. This custom was continued until the last revision of the Prayer Book in 1661; but in 1552 the word "confess" in the rubric (used in the sense of confessing or professing our belief) was unfortunately altered to "confirm," and the rubric being then adopted as a preliminary address in the Confirmation Service (while that which had been referred to by the word was removed from it), a confusion of ideas was originated which connected the expression "ratify and confirm" with the ordinance of laying on of hands instead of with the catechizing by which it is preceded [see notes on Confirmation].

The Catechism which thus stood in the Prayer Book from 1549 to 1661 (under both the general title "Confirmation, wherein is contained a Catechism for children," and the particular one by which it is now alone headed), was nearly identical with the present one, but only extended as far as the end of the

¹ "In *κατήχῃσις* is included an iteratibn, and from *ἠχῆσις* we have our word *echo*. 'ἠχῆσις' is indeed 'to sound the last syllable,' and such sounders haply there are enough; but *κατήχῃσις* is 'to sound in the whole, after one again.' And such is the repetition which is required of the right and true *κατηχουμένοις*, young catechized Christians, and those places are called *κατηχῃσις* that give the whole verse or word again." [Bp. Andrewes' Introduction to Pattern of Catechetical Doctrine.]

² St. Cyril's Exposition of the Lord's Prayer may be found at p. 31.

explanation of the Lord's Prayer¹. It has often been said to have been made by Alexander Nowell, who was second master of Westminster School at the time when the Prayer Book was in preparation, but Dean of St. Paul's from 1560 to 1602. It has also been attributed to Bishop Poynt, who (at the age of thirty-three) was made Bishop of Rochester in 1550. But it is very unlikely that a young second master of Westminster School would have been entrusted with so grave an undertaking by the Divines who set forth the Prayer Book of 1549: and although Poynt published a Catechism in Latin and English, the licence to print it was only asked from Cecil by the Earl of Northumberland on September 7th, 1552². Poynt had, however, been one of Cranmer's chaplains.

The name of Goodrich, Bishop of Ely, has also been associated with the authorship of a part of the Catechism. The authority for this is a stone tablet on the east side and another on the west of a spacious bow in a gallery which he built on the north side of the palace at Ely. These tablets have engraved upon them "our duty to God," and "our duty to our neighbour," in the words now so familiar to every child. The date upon them is 1552, and they are reasonably supposed to have been put up by Goodrich. As he was one of the Committee of Convocation by whom the Prayer Book was prepared³, there is no improbability in the supposition that these portions of the Catechism came from his pen; and if they did so, it may be fairly concluded that the remaining portions of it (as it stood at first) are his also.

The latter part of the Catechism was added by the authority of King James I., after the Hampton Court Conference⁴, the Puritans complaining through Dr. Reynolds that it was too short in its existing form⁵. "The addition," says Cosin, "was

first penned by Bishop Overall (then Dean of St. Paul's) and allowed by the bishops" [Cosin's Notes, p. 491, Ang. Cath. Lib.]. Many other writers repeat the statement.

As Bishop Cosin wrote this about 1640, twenty years only after Overall's death; and as he had, in his early life, been chaplain to that good and learned Divine, no doubt he had authority for his statement; but it is also pretty well established, from internal evidence, that Overall translated from some Latin formula, probably from an ancient "A. B. C., with the Catechism," of unknown authorship, which was used in St. Paul's School, and of which there is a reprint dated 1687⁶.

As in many other particulars, so in the matter of Catechizing, the Reformation rekindled a principle and a practice which had been gradually becoming extinguished in that decadence of spirituality which had been the bane of the Church of England for a century or more, and from which the Reformation itself was a re-action. Accordingly in a set of Injunctions framed by Cranmer and issued by authority of Henry VIII. in 1536, the fifth was a reiteration of the rule so often to be met with in mediæval times, that the clergy should take care children were taught the Creed, the Lord's Prayer, and the Ten Commandments in their mother tongue⁷. This rule had been so neglected (it is stated in the Homily against Disobedience and wilful Rebellion) that few even of the most simple people were taught them except in Latin, which they of course could not understand. In the Injunctions of Edward VI. [1547] this duty was again enforced upon the clergy in the following words:—"Item. That every holyday throughout the year, when they have no sermon, they shall immediately after the Gospel, openly and plainly recite to their parishioners, in the pulpit, the Paternoster, the Credo, and the Ten Commandments in English, to the intent the people may learn the same by heart; exhorting all parents and householders to teach their children and servants the same, as they are bound by the law of God, and in conscience to do Item. That they shall in confessions every Lent, examine every person that cometh to confession to them, whether they can recite the articles of their faith, the Paternoster, and the Ten Commandments in English, and hear them say the same particularly⁸." The Catechism was a natural development of this ancient and now revived practice. It appeared in the Prayer Book which was completed in the year [1548] following the above Injunctions; and at the end of the Confirmation Service, of which it formed a part, was the following rubric:—"¶ The Curate of every parish, once in six weeks at the least, upon warning by him given, shall, upon some Sunday or Holyday, half an hour before Evensong, openly in the Church instruct and examine so many children of his parish sent unto him, as the time will serve, and as he shall think convenient, in some part of this Catechism. And all fathers, mothers, masters, and dames shall cause their children, servants, and apprentices (which are not yet confirmed) to come to the Church at the day appointed, and obediently hear and be ordered by the Curate, until such time as they have learned all that is here appointed for them to learn. ¶ And whensoever the Bishop shall give knowledge for children to be brought afore him to any convenient place for their confirmation, then shall the Curate of every parish either bring or send in writing the names of all those children of his parish which can say the Articles of their Faith, the Lord's Prayer, and the Ten Commandments; and also how many of them can answer to the other questions contained in this Catechism." In the previous Injunctions it had been ordered that none should be admitted to the Holy Communion until they could say these three primary summaries of Faith, Prayer, and Duty. A rubric following the above now embodied this rule in a different form,—“¶ And there shall none be admitted to the Holy Communion until such time as he be confirmed.” In 1549

¹ There is a Catechism in the Confirmation Office (such as it is) of Hermann's "Consultation" which bears a general resemblance to that in the Prayer Book, and from which hints were probably taken for the composition of the latter. Some of its questions and answers will thus be of interest to the reader. They are given from Bishop Cosin's copy of Daye's transl. of 1537.

Demand. Dost thou profess thyself to be a Christian?

Answer. I profess.

Demand. What is it to be a Christian?

Answer. To be born again in Christ, and to have remission of sins, and participation of everlasting life through Him.

Demand. Whereby trustest thou that these things be given thee?

Answer. Because I am baptized in the Name of the Father, the Son, and the Holy Ghost.

Demand. What believest thou of God the Father, the Son, and the Holy Ghost?

Answer. The same that the Articles of our Creed do comprehend.

Demand. Rehearse them.

Answer. I do believe in God the Father Almighty, &c.

¶ Here let the child in this place recite all the articles of the Creed plainly and distinctly.

[After which follow questions on each article of the Creed, some of the answers being very long. These are followed by a repetition of the vows made at Baptism by the catechumen, and a statement of Christian duty. Some questions upon the Holy Communion are the only others that have any verbal resemblance to the Catechism of the Prayer Book.]

Demand. What doth the Communion of the congregation of Christ require besides?

Answer. It requireth also, that I receive the Supper of the Lord with other Christian men, to whom I come, and with whom I dwell, as one, that is one bread, and one body with them in Christ.

Demand. What is this Sacrament?

Answer. It is the communion of the Body and Blood of Christ, which, in the Lord's Supper, when it is celebrated according to the Institution of the Lord, be truly exhibited with the bread and wine.

Demand. Wilt thou faithfully perform and observe all these things, as thou hast now professed?

Answer. I will, by the help of our Lord Jesus Christ.

There is no rehearsal of the Ten Commandments or of the Lord's Prayer in this Catechism of Hermann; and it bears much more mark of temporary controversies than that in the Prayer Book.

² State Papers, Domestic. Edw. VI., xv. 3.

³ See Hist. Introd. p. xxii.

⁴ Hist. Introd. p. xxxvii.

⁵ Much information about the long Catechisms of the Protestant Reformers may be found in Walchius, Bibl. Theol. vol. i. Nowell's Catechisms were republished at Oxford in 1835. The voluminous Catechism of the Council of Trent is in many respects a valuable summary of Christian doctrine, but was intended as a book of instructions for the clergy, and not for the use of children.

⁶ As Erasmus and Colet were very intimate, it is not improbable that this Catechism may have originated with the former, who was a great authority at the time of the Reformation.

⁷ See Hist. Introd. p. xxiii.

⁸ Cardw. Doc. Ann. i. 7. 10.

other Injunctions were issued; and the eighth is, "*Item*. That the Curates every sixth week at the least, teach and declare diligently the Catechism, according to the book of the same¹." The forty-fourth of Queen Elizabeth's Injunctions of 1559 reiterates that of Edward VI., altering the time to "every holy-day, and every second Sunday in the year²." All these Injunctions were embodied in the fifty-ninth Canon of the Church of England in the year 1603³.

"Canon 59.

"*Ministers to Catechize every Sunday.*

"Every Parson, Vicar, or Curate, upon every Sunday and Holy-day, before Evening Prayer, shall, for half an hour or more, examine and instruct the youth and ignorant persons in his parish, in the Ten Commandments, the Articles of the Belief, and in the Lord's Prayer; and shall diligently hear, instruct, and teach them the Catechism set forth in the Book of Common Prayer. And all fathers, mothers, masters, and mistresses, shall cause their children, servants, and apprentices, which have not learned the Catechism, to come to the Church at the time appointed, obediently to hear, and to be ordered by the Minister, until they have learned the same. And if any Minister neglect his duty herein, let him be sharply reprov'd upon the first complaint, and true notice thereof given to the Bishop or Ordinary of the place. If, after submitting himself, he shall willingly offend therein again, let him be suspended; if so the third time, there being little hope that he will be therein reformed, then

excommunicated, and so remain until he will be reformed. And likewise if any of the said fathers, mothers, masters, or mistresses, children, servants, or apprentices, shall neglect their duties, as the one sort in not causing them to come, and the other in refusing to learn, as aforesaid; let them be suspended by their Ordinaries (if they be not children), and if they so persist by the space of a month, then let them be excommunicated."

The present Rubric so far supersedes this Canon that it directs the clergyman to catechize after the Second Lesson at Evening Prayer. It is plain, that both Canon and Rubric contemplate catechizing as an open and public Ministration in the Church, and in the face of a congregation: and however diligently *school* catechizing may be carried on, it cannot be considered as adequately satisfying the law of the Church, or as being equivalent to a solemn ministration conducted in the House of God. The value of such a ministration has been testified by innumerable writers of former centuries and of modern times in the Church of England: and the catechetical works of Bishop Andrewes, Hammond, Bishop Nicholson, Bishop Ken, and (in our own times) Bishop Nixon, show how our best Divines have recognized in the Catechism, and in the practice of public catechizing, a duty and a labour upon which the highest intellectual powers may be profitably exercised for the good of Christ's little ones, and of the Church at large.

It is obvious from the history of the Catechism, that it was formed upon the basis of the Creed, the Lord's Prayer, and the Ten Commandments. To these and to the catechetical exposition connected with them, was prefixed a fourth division on the Christian nature and covenant; and at the end was afterwards added a fifth division on the Sacraments. It has thus become a comprehensive summary respecting (1) the relation between God and Christians, (2) Faith, (3) Duty, (4) Prayer, (5) Grace. But although thus happily comprehensive, it must be remembered, that it does not profess to be exhaustive: and that when the Puritans at the Savoy Conference wished it to be made longer by adding questions on justification, sanctification, &c., the Bishops replied, "The Catechism is not intended as a whole body of divinity, but as a comprehension of the Articles of Faith, and other doctrines most necessary to salvation."

¹ Cardw. Doc. Ann. i. 64.

² *Ibid.* 195.

³ In the "*Liber quorundam Canonum*" of 1571, there is one which enjoins the duty of catechizing very strongly. ". . . Et ut omnes intelligant quid debeant Deo Optimo Maximo, quid Principi, quem colere ac venerari debent ut Vicarium Dei: quid legibus: quid magistratibus, quid fratribus suis: quid populo Dei: omnibus dominicis et festis diebus statim a meridie preesto erunt in templis, ibique minimum ad duas horas legent, et docebunt Catechismum, et in eo instituent omnes suos omnium aetatum, atque ordinum, non tantum puellas aut pueros, set etiam si opus erit grandiores." [Sparrow's Collection.] The "at least two hours" may be profitably annotated by an extract from a letter of Archbishop Parker to Bishop Parkhurst, "For it is not intended by our canons that every thing should be so precisely kept, but for the most part, and as occasion of edification should require." Parker Correspondence, p. 389.

A CATECHISM,

THAT IS TO SAY,

AN INSTRUCTION TO BE LEARNED OF EVERY PERSON, BEFORE HE
BE BROUGHT TO BE CONFIRMED BY THE BISHOP.

Question.

WHAT is your Name?

Answer.

N. or M.

Question.

Who gave you this Name?

Luke i. 4.
1 Pet. iii. 21.
2 Tim. i. 13.
Luke i. 59. ii. 21.

Answer.

My Godfathers and Godmothers in
my Baptism; wherein I was made a
member of Christ, the child of God,
and an inheritor of the kingdom of
heaven.

1 Cor. xii. 12-14.
27.
Gal. iii. 26, 27.
Rom. viii. 17.

THE CATECHISM.

What is your Name? The Christian name is used in the Ministrations of the Church, at Baptism, here, and in the Marriage Service. It was formerly used also at Confirmation. In this place it obviously singles out, by a sort of analysis, the individual Christian from the Christian body at large, and thus fixes on the idea of *individual* privilege, duty, and responsibility, while at the same time not interfering with the prominency of the idea of corporate unity which is contained in that of membership.

N. or M. The most probable explanation of these letters is, that N was anciently used as the initial of Nomen, and that Nomen vel Nomina was expressed by N vel NN ; the double N being afterwards corrupted into M . The M by which 1000 is expressed, was formed in a somewhat similar manner from the ancient notation, CIC , by which that number was expressed in classical Latin, and which became M in the Teutonic character of later inscriptions.

in my Baptism; wherein I was made This answer is very comprehensive, and offers a concise definition of doctrine respecting the Christian nature. It declares that Christians are made such by God's work co-operating with the work of the person baptizing. The infant was dipped in water, or had water poured upon it, while the person baptizing named it, and said, "I baptize thee in the Name of the Father, and of the Son, and of the Holy Ghost." This constituted "my Baptism," so far as man's work could effect it. "In" that Baptism, without leaving room for any doubt, without imposing any condition by which the blessing could be nullified, God "made me a member of Christ, the child of God, and an inheritor of the Kingdom of Heaven." The new birth is not conditional on the regenerated person's subsequent fulfilment of the Baptismal vows, but only upon the due administration of the water and words of Baptism.

a member of Christ This is a Scriptural expression, used by St. Paul, who says, "We are the body of Christ, and members in particular" [1 Cor. xii. 27]: also, that "by one Spirit are we baptized into one body for the body is not one member, but many" [Ibid. xiii. 14]: also that this Body in its completeness is Christ,— "As the body is one, and hath many members, so

also is Christ" [Ibid. 12]: "For we are members of His Body, of His flesh, and of His bones." [Eph. v. 30.] How this membership can be is a mystery, but the results of it are intelligible, and may be understood partly from analogy, partly from the statements of our Lord and His Apostles. By physiological analogy we may draw the inference, that life is maintained in every member by union with the Head, and without that union no member can live. Hence spiritual life is derived from our Lord the Fountain of life, not only as a gift bestowed by one person upon another, but by an actual, though mysterious, and therefore unintelligible union.

It is on such a principle that St. Paul founds his familiar but deeply-important words, "He is the Head over all things to the Church, which is His Body, the fulness of Him Which filleth all in all." [Eph. i. 22, 23.] "And He is the Head of the Body, the Church." [Col. i. 18.] To baptize an infant is, therefore, to give it spiritual life by uniting it to Christ. To leave an infant unbaptized, is to leave it spiritually without life, by leaving it without this union. And the same is true, no wilful bar to the Sacrament intervening, of adults. Our Lord showed this in describing Himself as the true Vine, and the Apostles as branches; and especially in the words, "I am the Vine, ye are the branches: he that abideth in Me, the same bringeth forth much fruit: for without Me [$\chi\alpha\rho\iota\varsigma$ Ἐμοῦ] ye can do nothing." To be made a "member of Christ" is, therefore, to be united in a living spiritual bond with "the Way, the Truth, and the Life," "the Light," "the Resurrection and the Life." Our spiritual existence, our spiritual knowledge, and our future Resurrection to life eternal, are dependent on that union being effected in and by Baptism.

the child of God This term also is Scriptural. St. Paul uses it thus: "For ye are all the children of God by faith in Christ Jesus" [Gal. iii. 26]: and St. John, "Behold, what manner of love the Father hath bestowed upon us, that we should be called the sons of God Beloved, now are we the sons of God." [1 John iii. 1, 2.] Such a relationship also springs from actual union with God through Christ in regeneration, and not from federal relationship. So St. Paul alleges when he writes, "For both He that sanctifieth, and they that are sanctified, are all of one: for which cause He is not ashamed to call them brethren."

Question.

What did your Godfathers and Godmothers then for you?

Answer.

Isa. xix. 21.
1 John iii. 8.

all his works and
poms, the vani-
ties of, &c.,
1549-61.

They did promise and vow three things in my name. First, that I should renounce the devil and all his

works, the pomps and vanity of this wicked world, and all the sinful lusts of the flesh. Secondly, that I should believe all the Articles of the Christian Faith. And, thirdly, that I should keep God's holy will and commandments, and walk in the same all the days of my life.

Gal. i. 4. v. 24.
Mark xvi. 16.
Matt. xxviii. 20
xxii. 37-39.
Luke i. 74, 75.

[Heb. ii. 11.] So also St. John alleges in the words, "Whosoever believeth that Jesus is the Christ is born of [γεννηται] God: and every one that loveth Him that begat [τον γεννησαντα], loveth also him that is begotten of Him" [τον γεγεννημενον εξ Αδου]. To be the child of God is not only therefore to be taken into that relationship by a covenant, but to be made so by a supernatural effect of grace.

[an inheritor of the kingdom of heaven] St. Paul writes that sonship brings heritage,—“If children, then heirs; heirs of God, and joint heirs with Christ.” [Rom. viii. 17.] The inheritance is (1) of the Church Militant, which our Lord speaks of as the Kingdom of Heaven on many occasions [e. g. Matt. iii. 2; xiii. 24]: and (2) of the Church Triumphant, of which He also speaks under the same title. [Matt. xxv. 34.] The heritage of the Church Militant is a title to all Church privileges and teaching, to benediction, absolution, all sacramental rites, the blessed Sacrament, and burial within the fold of the Church, and may be described as a title to the grace of God (through His mercy, and not through our merits), which title can, of course, be forfeited by sin. The heritage of the Church Triumphant is the gift of blessedness which “eye hath not seen nor ear heard.”

St. Augustine writes respecting both: “Wherefore, dearly beloved, Catholic plants, members of Christ, think what a Head ye have! Children of God, think what a Father ye have found! Christians, think what an Inheritance is promised you! Not such as on earth cannot be possessed by children, save when their parents are dead. For no one on earth possesses a father's inheritance save when he is dead. But we, whilst our Father liveth, shall possess what He shall give: for that our Father cannot die. I add more, and say the truth, our Father will Himself be our inheritance.” [Aug., Sermons, cxlvi. 2.] As children could never grow up if they refused the food and shelter of their parents' home, so the children of God can never grow to “the fulness of the stature of Christ” if they refuse the present privileges to which they are entitled in the Church of God. And while “not growing up” in the one case means physical death, so does it mean spiritual death in the other: an excision of the unfruitful branch, the unworthy member of Christ; an expatriation of the prodigal son for ever from his father's house; a forfeiture of the eternal inheritance to which the spiritual birth-right has entitled, but of which the disentanglement has been signed and sealed by the heir of his own free will.

[They did promise and vow . . . in my name] Baptism is not administered on the condition of vows being made, nor do the vows exercise any anticipative influence upon it. They are part of the discipline of the Church, and probably established by the Apostles, but do not belong to the essence of the Sacrament, which is entirely perfect as to its outward form and its inward grace, even where they are not used or intended to be used: At the same time, the vows of Baptism express obligations which are inseparable from the relation established with our heavenly Father by it: so that children who have never had God-parents to make them on their behalf are bound, by the nature of their position as Christian children, to the duties stated in these vows, as much as if they had been explicitly made at their Baptism. A child who has not made any verbal promise of obedience to its parents, is as much bound to obey, by the law of God, as one who has done so: and no superadded vow can heighten or intensify the obligations which naturally belong to the relationship of Christians towards God, though it may express and define them.

[that I should renounce the devil] Sins, or the works of the devil, are classified under seven kinds, viz., Pride, Avarice, Lust, Envy, Gluttony, Anger, Sloth, which are called the seven deadly sins. The renunciation of the adversary of God and man, which was made by those who were children of wrath before they became children of God, expressed an obligation from which they could never after become free. St. John appears to refer to this renunciation when he says, “I write unto you, young men, because ye have overcome the wicked one” [1 John ii. 13]. In what manner practical effect is to be given, throughout life, to that renunciation, he also shows by referring (1) to the victory gained by Christ our Head; and (2) to the union between Him and His members, through which they may be made partakers of His strength. “For this purpose the Son of God was manifested, that He might overcome the works of the devil.” “Greater is He that is in you, than he that is in the world.” [1 John iii. 8; iv. 4.] Thus the true way to give practical force to the vow of renunciation is to gain the power of Christ, (1) by the wish to do good rather than evil; (2) by dependence, in faith, on our Lord the Victor of the Evil One; (3) by an earnest resistance to Satan; (4) by a continued use of the grace given by God. [Cf. Litany clause, “From all the deceits of the world, the flesh, and the devil;” and Collect for Eighteenth Sunday after Trinity.]

[that I should believe . . . the Christian Faith] Such an act of faith presupposes a faculty of faith, just as an act of reason supposes a faculty of reason. The one belongs to our spiritual nature, which we receive at Baptism; the other to the nature which we receive by our natural birth. Faith is the power of believing all that God reveals to us without the necessity of any corroboratory evidence from our senses. Such corroboratory evidence sometimes accompanies the revelation of God; but in respect to the most important objects of faith it does not: and our Lord commends that faith most highly which is exercised without it: “Thomas, because thou hast seen Me, thou hast believed: blessed are they that have not seen, and yet have believed” [John xx. 29]. The “Articles of the Christian Faith” are so much concerned with objects of faith respecting which we can have little or no evidence beyond God's word for their existence and truth, that a thorough belief in them can only be entertained by the exercise of the faith which is the gift of God, and which enables us to know, by a participation in God's knowledge, what is altogether beyond the reach of unassisted intellectual apprehension. Hence, as belief in all the Articles of the Christian Faith is a duty imposed upon Christians with their birth-right, so it is the exercise of a gift or faculty which belongs to the Christian nature. A partial faith, an *assent and submission of the intellect* is, of course, possible to all who possess reason, and is a necessary qualification for Baptism in adult persons. It may be added, that the difference between faith and superstition is that the first is belief on good evidence (of which the best and highest kind is God's word about the object upon which faith is to be exercised); while superstition is belief on insufficient evidence, of which kind is, sometimes, the evidence of the senses.

On the necessity of a right faith to salvation, see notes on the Athanasian Creed, pp. 42-45. Compare also Jude 3. Eph. iv. 5. 1 John v. 4. 1 Pet. v. 9. Rev. ii. 13; xiv. 12,—the clause “From all false doctrine,” &c., in the Litany; and the Collect for St. Thomas's Day.

[that I should keep God's holy will] God's will is the supreme

Question.

Deut. xxvi. 17—
19.
James ii. 17.

Dost thou not think that thou art bound to believe, and to do, as they have promised for thee?

Answer.

Ps. cxlvi. 5.
Eph. v. 20.
2 Tim. i. 9.
Tit. ii. 11.
Phil. iv. 6. 1. 6.
ii. 13.

Yes verily; and by God's help so I will. And I heartily thank our heavenly Father, that he hath called me to this state of salvation, through Jesus Christ our Saviour. And I pray unto God to give me his grace, that I may continue in the same unto my life's end.

2 Tim. iii. 14.

Catechist.

Rehearse the Articles of thy Belief.

Answer.

I BELIEVE in God the Father Almighty, Maker of heaven and earth:

And in Jesus Christ his only Son our Lord, Who was conceived by the Holy Ghost, Born of the Virgin Mary, Suffered under Pontius Pilate, Was crucified, dead, and buried, He descended into hell; The third day he rose again from the dead; He ascended into heaven, And sitteth at the right

hand of God the Father Almighty; From thence he shall come to judge the quick and the dead.

I believe in the Holy Ghost; The holy Catholick Church; The Communion of Saints; The Forgiveness of sins; The Resurrection of the body; And the Life everlasting. Amen.

Question.

What dost thou chiefly learn in these Articles of thy Belief?

Answer.

First, I learn to believe in God the Father, who hath made me, and all the world.

Heb. xi. 6.
1 Cor. viii. 6.
John xiv. 1.
1 John iv. 14.

Secondly, in God the Son, who hath redeemed me, and all mankind.

Acts v. 3, 4.
1 Pet. i. 1, 2.

Thirdly, in God the Holy Ghost, who sanctifieth me, and all the elect people of God.

Question.

You said, that your Godfathers and Godmothers did promise for you, that you should keep God's Commandments. Tell me how many there be?

Exod. xix. 5, 7.
8.
Ps. lxxvi. 11.

Answer.

Ten.

Exod. xxxiv. 28.

law over all; and His commandments are the expression of that will. This expression is by no means to be limited in our minds by the Ten Commandments, though these contain a summary of all moral duty; for the will of God is expressed in many other ways. Of such modes by which that Will is expressed, there are five principal ones. (1) By the natural relationships of life. Thus St. Paul shows that the duties of children towards their parents, of wives towards their husbands, and *vice versa*, are duties laid upon them by God. [Col. iii. 18, &c.] Duties so plainly imposed by our heavenly Father are a plain revelation of His Will; and the non-fulfilment of such duties is disobedience to it. (2) By the light of the Christianized conscience, which is "the candle of the Lord within" [Prov. xx. 27], "the light that is in thee," of which our Saviour spoke when He said, "If therefore the light that is in thee be darkness, how great is that darkness!" [Matt. vi. 23.] But all *apparent* dictates of the Christian conscience are not hastily to be taken as such revelations of God's will and commandment, as natural inclination may be mistaken for the voice of conscience. (3) By the voice of the Church, represented in its Catholic teaching; and in the admonitions and advice of those individual ministers whom God has appointed as spiritual guides to the flocks in the midst of which He has placed them. (4) By the written word of God's revelation, contained in the Holy Bible. (5) By the written and unwritten law of the land in which His Providence has placed us, respecting which St. Paul says, "Let every soul be subject to the higher powers. For there is no power but of God: the powers that be are ordained of God. Whosoever therefore resisteth the power resisteth the ordinance of God, and they that resist shall receive to themselves damnation." [Rom. xii. 12.] Obedience to the will and commandment, however it may be revealed, draws our relationship to Him still closer; Christian nature and Christian obedience thus reacting upon each other, and fulfilling the

words of Christ,—“Whosoever shall do the will of God, the same is My brother, and My sister, and mother.” [Mark iii. 35.]

by God's help so I will]. This answer takes the form of an oath, the ordinary adjuration of which in this country is, "So help me God." Every time it is repeated, the child or person repeating it "renews the solemn promise and vow that was made in their name at their Baptism; ratifying and confirming the same in their own persons, and acknowledging themselves bound to believe and do all those things which their Godfathers and Godmothers then undertook for them." [See Confirmation Office.] This is done for the last time immediately before Confirmation by the reply, "I do," to the bishop's question. It must be remembered that the promise and vow made on behalf of a child by its God-parents do not *originate* the obligation of that child "to do all these things," but only *express* an obligation that would be binding whether it was expressed or not.

this state of salvation] That is, into a Christian condition in which it is quite certain (whatever may be the possibility in a non-Christian condition) that salvation is within reach. The Christian child has already been saved from the *guilt* of original sin, and from much of its power over the soul. Final salvation depends on final perseverance, that is, on a continuance in the state of salvation, by God's grace, to our lives' end, so that we may not die in mortal sin.

First, I learn to believe] For an expository paraphrase on the Apostles' Creed, see the notes on Morning Prayer, page 20. Illustrative texts of Scripture will be found in the marginal references to the Creed there and elsewhere throughout the book.

Ten] In the Catechism as it stood in 1549, the first five of the Ten Commandments were given in a much shorter form, as follows¹ :—

¹ That a compendium of the Ten Commandments is perfectly justifiable

Question.

Matt. xxii. 37—40.

Which be they ?

Answer.

Exod. xx. 2—17.
Deut. v. 6—21.
Matt. xix. 18, 19.
Mark xii. 30—33.
Luke x. 27.
Rom. xiii. 9.

THE same which God spake in the twentieth Chapter of Exodus, saying, I am the Lord thy God, who brought thee out of the land of Egypt, out of the house of bondage.

I. Thou shalt have none other gods but me.

II. Thou shalt not make to thyself any graven image, nor the likeness of any thing that is in heaven above, or in the earth beneath, or in the water under the earth. Thou shalt not bow down to them, nor worship them : for I the Lord thy God am a jealous God, and visit the sins of the fathers upon the children, unto the third and fourth generation of them that hate me, and shew mercy unto thousands in them that love me, and keep my commandments.

III. Thou shalt not take the Name of the Lord thy God in vain : for the Lord will not hold him guiltless that taketh his Name in vain.

IV. Remember that thou keep holy the Sabbath-day. Six days shalt thou labour, and do all that thou hast to do ; but the seventh day is the

Sabbath of the Lord thy God. In it thou shalt do no manner of work, thou, and thy son, and thy daughter, thy man-servant, and thy maid-servant, thy cattle, and the stranger that is within thy gates. For in six days the Lord made heaven and earth, the sea, and all that in them is, and rested the seventh day ; wherefore the Lord blessed the seventh day, and hallowed it.

V. Honour thy father and thy mother, that thy days may be long in the land which the Lord thy God giveth thee.

VI. Thou shalt do no murder.

VII. Thou shalt not commit adultery.

VIII. Thou shalt not steal.

IX. Thou shalt not bear false witness against thy neighbour.

X. Thou shalt not covet thy neighbour's house, thou shalt not covet thy neighbour's wife, nor his servant, nor his maid, nor his ox, nor his ass, nor any thing that is his.

Question.

What dost thou chiefly learn by these Commandments? Matt xxiii. 37—40.

Answer.

I learn two things: my duty towards

"I. Thou shalt have none other gods but me.

"II. Thou shalt not take the name of the Lord thy God in vain.

"III. Thou shalt not nor worship them.

"IV. Remember that thou keep holy the Sabbath-day.

"V. Honour thy father and thy mother."

In the tenth commandment the words, "Thou shalt not covet thy neighbour's house," were altogether omitted, evidently by a singular accident. The Primer of 1545 contains "The Ten Commandments compendiously extracted," &c., which is exactly similar to the arrangement of 1549, except that the commandment there put as the second is omitted [it is printed in the exposition immediately preceding], and the tenth is divided into two. The writer of the Catechism must have copied out the compendium from the Primer, inserting so much as he did insert of the second commandment, and then forgetting altogether what there stood as the ninth!

The translation of the Commandments here, and in the Communion Office, is that of the "Great Bible" of 1540, that from which the Psalter is printed. The Puritans of 1661 wished to have that of 1611 substituted, but the bishops considered that there was no necessity for this change.

The same which God spake] Although the Ten Commandments were given especially to the Jews, they represent the whole sub-

stance of a moral law which is equally binding upon Christians. Thus our Lord recognized the summary of them which was given to Him by the lawyer, in Luke x. 27, and thus He summed them up Himself, in Matt. xix. 18, and xxii. 37—40, as a rule of obedience by which a man might "enter into life," and on which "hang all the law and the prophets." As, moreover, a greater measure of grace is bestowed upon Christians than was given to the Jews, so is the moral law interpreted to them by a more strict rule. Christ came, "not to destroy the law, but to fulfil it," and "the law was our schoolmaster, to bring us unto Christ;" so that we "serve in newness of spirit, and not in the oldness of the letter," as children yielding a willing, not as servants yielding a forced, obedience.

I learn two things] The division of the Ten Commandments into the four which enjoin duties towards God, and the six which summarize duties towards man, was sanctioned and adopted by our Blessed Lord, and was probably derived from the manner in which they were written on the "two tables" brought down by Moses from Sinai, and preserved in the ark under the mercy-seat within the Holy of Holies.

my duty towards God] This summary exposition of the first four commandments sets forth first the mental qualities which are comprehended in a Christian disposition towards God, which are Faith, Fear, and Love; and, secondly, the acts by which the exercise of those qualities is manifested, which are principally Worship, Prayer, and faithful Service. Acts of worship are such offerings of praise as are made to God without any consideration of recompense, and the highest of such acts is the "sacrifice of

may be concluded from its adoption by our Lord in Matt. xix. 18, and by St. Paul in Rom. xiii. 9.

God, and my duty towards my Neighbour.

Question.

What is thy duty towards God ?

Answer.

2 Chron. xx. 20.
Luke xii. 5. x.
27.
John iv. 23.
1 Thess. v. 18.
1 Tim. iv. 10.
Phil. iv. 6.
Ps. cxxxviii. 2.
1 Chron. xxviii. 9.

My duty towards God, is to believe in him, to fear him, and to love him with all my heart, with all my mind, with all my soul, and with all my strength; to worship him, to give him thanks, to put my whole trust in him, to call upon him, to honour his holy Name and his Word, and to serve him truly all the days of my life.

Question.

What is thy duty towards thy Neighbour ?

Answer.

Rom. xiii. 8—10.
Matt. vii. 12. xv.
4—6.
Eph. vi. 2, 3.
1 Pet. ii. 13, 14.
17.
Tit. iii. 1.
Heb. xiii. 7. 17.
Tit. ii. 9, 10.
1 Pet. v. 5.
Lev. xix. 32.
Rom. xii. 17—21.
Phil. iv. 8.
James iii. 14. 16.
Eph. iv. 28. 25.
31.
James i. 26.
Luke xxi. 34.
1 Cor. vi. 13.
2 Cor. vii. 1.
Heb. xiii. 5.
1 Thess. iv. 11,
12.
2 Cor. vii. 20—22.
Eccles. xii. 13.

My duty towards my Neighbour, is to love him as myself, and to do to all men, as I would they should do unto me: To love, honour, and succour my father and mother: To honour and obey the Queen, and all that are put in authority under her: To submit myself to all my governours, teachers, spiritual pastors and masters: To order myself lowly and reverently to all my betters: To hurt no body by word nor deed: To be true and just in all my dealing: To bear no malice nor hatred in my heart: To keep my hands from picking and stealing, and my tongue from evil-speaking, lying, and slander-

ing: To keep my body in temperance, soberness, and chastity: Not to covet nor desire other men's goods; but to learn and labour truly to get mine own living, and to do my duty in that state of life, unto which it shall please God to call me.

Catechist.

My good child, know this, that thou art not able to do these things of thyself, nor to walk in the Commandments of God, and to serve him, without his special grace; which thou must learn at all times to call for by diligent prayer. Let me hear therefore, if thou canst say the Lord's Prayer.

Answer.

OUR Father, which art in heaven, Hallowed be thy Name. Thy kingdom come. Thy will be done in earth, As it is in heaven. Give us this day our daily bread. And forgive us our trespasses, As we forgive them that trespass against us. And lead us not into temptation; But deliver us from evil. Amen.

Question.

What desirest thou of God in this Prayer? Matt. vi. 7—13.

Answer.

I desire my Lord God our heavenly Father, who is the giver of all goodness, to send his grace unto me, and to all people; that we may worship James i. 17.
Matt. vii. 7—11.
Ps. cxxxix. 2. 9.
lxxxix. 7.
Exod. xix. 5.
Matt. vi. 25—33.
12—15. xxvi.
41.

praise and thanksgiving" comprised in the celebration of the Holy Eucharist, as distinct from the consumption of it, which afterwards constitutes the act of Communion. Upon such acts, Faith, holy Fear, and Love are all exercised in their highest degree. Acts of Prayer are such offerings of worship as are mingled with supplications for some spiritual or temporal benefit; and upon these, too, all three qualities are exercised. Acts of faithful Service are other practical evidences and exertions of those qualities in the work of life; and by them the labour appointed to us in the world is transfigured into Christian work, done also in the Kingdom of God. The intensification of the law under the Christian dispensation is here shown by the declaration that such faithful service is due to God, not only on the Sabbath, which was a temporary institution, but on "all the days of my life," since all a Christian's days are to be consecrated in some way to God. A practical Trust in the Providence of God is necessarily involved in such faithful service; and reverence for His holy Name and Word is inseparable from a faithful, humble, and loving habit of worship.

My duty towards my Neighbour] The details of this answer are in themselves a sufficient comment upon, and illustration of, the six commandments to which they refer. They are also an exposition of the practical duties arising from our Lord's commandment as given in the Sermon on the Mount: "Therefore all

things whatsoever ye would that men should do to you, do ye even so to them: for this is the law and the prophets" [Matt. vii. 12]. Some portions of this answer seem to be taken from St. Augustine, who thus speaks of the obligations of Sponsors:—"Admoneant, ut castitatem custodiant, virginitatem usque ad nuptias servent, a maledicto vel perjurio linguam refrudent, cantica turpia vel luxuriosa ex ore non proferant, non superbiant, iracundiam vel odium in corde non teneant . . . sacerdotibus et parentibus honorem amore veræ caritatis impendant." [Serm. de Temp. clxiii.]

What desirest thou of God in this Prayer?] In the Notes to Evening Prayer, p. 31, will be found an Exposition of the Lord's Prayer taken from St. Cyril's Catechetical Lectures; at page 6, one by Bishop Andrewes; and at page 32, one by the author of the "Christian Year." The general objects of the seven petitions which compose it may be thus summed up¹:—

[I.] *Our Father, which art in heaven, Hallowed be thy Name.* In the first petition we pray that all things done on earth, all our actions as well as those of our brethren, may minister to the glory of God, that by our lives and in our hearts His Name may be hallowed.

[II.] *Thy kingdom come.* This is a prayer that all things

¹ See Denton on the Lord's Prayer, p. 153.

1 Cor. x. 13.
Ps. xix. 12, 13.
1 John v. 18.
2 Tim. iv. 18.
1 Pet. i. 5.
2 Cor. i. 20.

him, serve him, and obey him, as we ought to do. And I pray unto God, that he will send us all things that be needful both for our souls and bodies; and that he will be merciful unto us, and forgive us our sins; and that it will please him to save and defend us in all dangers ghostly and bodily; and that he will keep us from all sin and wickedness, and from our ghostly enemy, and from everlasting death. And this I trust he will do of his mercy and goodness, through our Lord Jesus Christ. And therefore I say, Amen, So be it.

Question.

HOW many Sacraments hath Christ ordained in his Church?

Answer.

Matt. xxviii. 18—
20.
Luke xxii. 19, 20. Two only, as generally necessary to salvation, that is to say, Baptism, and the Supper of the Lord.

Question.

What meanest thou by this word *Sacrament*?

Answer.

I mean an outward and visible sign of an inward and spiritual grace given unto us, ordained by Christ himself, as a means whereby we receive the same, and a pledge to assure us thereof.

John iii. 3, 5.
Tit. iii. 5.
John vi. 53, 54.

Question.

How many parts are there in a *Sacrament*?

Answer.

Two; the outward visible sign, and the inward spiritual grace.

Question.

What is the outward visible sign or form in *Baptism*?

Answer.

Water; wherein the person is bap-

Matt. xxviii. 9.
Acts x. 47.

here may tend to the propagation of the Gospel, the establishment of God's *kingdom* in all the world, and to the subjection of ourselves to the rule of our heavenly Father.

[III.] *Thy will be done in earth, As it is in heaven.* In the third petition we pray that we and all men may keep the commandments and do the whole will of God.

[IV.] *Give us this day our daily bread.* In the fourth petition we beseech God to give us day by day the *bread* we need, the food necessary for the strengthening and nourishing our body and soul; so that, sustained by His hand, we may be enabled to live to His glory.

[V.] *And forgive us our trespasses, As we forgive them that trespass against us.* In the next petition we ask God to forgive us those *trespasses* which have separated us from Him, and to restore us to that peace which by our actions we have disturbed, even as we forgive our brethren, and renew that concord which has been broken by our quarrels.

[VI.] *And lead us not into temptation.* In the sixth petition we pray for the protection and support of God against the assaults of the Evil one, the flesh, and the world, for deliverance from all *temptations*.

[VII.] *But deliver us from evil.* By the seventh petition we seek deliverance from all *evil* temporal and spiritual, and for the consummation of the work of God in our hearts and lives.

Two only, as generally necessary to salvation] The use of the word "generally" in the sense of "universally," may be illustrated by the two places in which it is to be found in the Holy Bible. The first is in 2 Sam. xvii. 11, "Therefore I counsel that all Israel be *generally* gathered unto thee, from Dan even to Beersheba:" the expression in the Vulgate being "*universus Israel*," and the LXX *πᾶς Ἰσραήλ*. The second is Jer. xlviii. 38, "There shall be lamentation *generally* upon all the house-tops of Moab;" where the Vulgate reads "*super omnia tecta Moab*," and the LXX *ἐπὶ πάντων τῶν δαυμάτων Μωάβ*. So also Bishop Hooper says, "Notwithstanding that God's promises be *general*, unto all *people of the world*, yet many shall be damned" [Declaration of the Ten Commandments]. Bishop Latimer, again, says, "The promises of Christ are *general*; they pertain to all *mankind*" [Sermon on Parable of King's Son]. And, lastly, in the Prayer for the Parliament is the expression "*this kingdom in general*," which clearly means the *whole of*

this kingdom, *all persons* therein. There are probably no instances to be found of any writer in the sixteenth or seventeenth centuries who used the word "generally" otherwise than with the meaning "universally;" and such is its meaning in this place. The Sacraments of Baptism and the Lord's Supper are therefore declared to be the only Sacraments which are necessary to the salvation of all persons; and, by implication, "those five commonly called Sacraments, that is to say, Confirmation, Penance, Orders, Matrimony, and extreme Unction" [Article 25], are necessary only for particular classes of persons. Among the Fathers the word *Sacrament* was used almost in the same sense that we now use the word *mystery*, and was not restricted to any particular number. "As for the number of them," says the Homily of Common Prayer and Sacraments, "if they should be considered according to the exact signification of a sacrament, namely, for visible signs expressly commanded in the New Testament, whereunto is annexed the promise of free forgiveness, and of our holiness and joining in Christ, there be but two, namely, Baptism and the Supper of the Lord. . . . But in a general acceptance the name of a Sacrament may be attributed to any thing whereby an holy thing is signified. In which understanding of the word, the ancient writers have given this name, not only to the other five commonly of late years taken and used for supplying the number of the Sacraments, but also to divers and sundry other ceremonies, as to oil, washing of feet, and such like; not meaning thereby to repute them as Sacraments in the same signification that the two forenamed Sacraments are. . . . And although there are retained by the order of the Church of England, besides these two, certain other rites and ceremonies about the institution of ministers in the Church, Matrimony, Confirmation of children . . . and likewise for the Visitation of the Sick; yet no man ought to take these for Sacraments, in such signification and meaning as the Sacraments of Baptism and the Lord's Supper are: but either for godly states of life, necessary in Christ's Church, and therefore worthy to be set forth by public action and solemnity by the ministry of the Church; or else judged to be such ordinances as may make for the instruction, comfort, and edification [i. e. *οικοδομησις*] of Christ's Church."

I mean an outward and visible sign] This definition is attributed to Peter Lombard, called the Master of the Sentences,

tized *In the Name of the Father, and of the Son, and of the Holy Ghost.*

Question.

What is the inward and spiritual grace ?

Answer.

John i. 12, 13.
Rom. vi. 3, 4, 7.
11. ix. 8.
Acts ii. 39.

A death unto sin, and a new birth unto righteousness; for being by nature born in sin, and the children of wrath, we are hereby made the children of grace.

Question.

What is required of persons to be baptized ?

Answer.

Acts ii. 38.
viii. 36, 37.
Heb. x. 22, 23.

Repentance, whereby they forsake sin; and Faith, whereby they stedfastly believe the promises of God made to them in that Sacrament.

Question.

Matt. xix. 14.
Gen. xvii. 7, 12, 13.

Why then are Infants baptized, when by reason of their tender age they cannot perform them ?

Answer.

Col. ii. 11, 12.
Deut. xxix. 10-15. 24, 25.

Because they promise them both by their Sureties; which promise, when they come to age, themselves are bound to perform.

Question.

Why was the Sacrament of the Lord's Supper ordained ?

Answer.

Luke xxii. 19.
Heb. ix. 26.

For the continual remembrance of the sacrifice of the death of Christ,

and of the benefits which we receive thereby.

Question.

What is the outward part or sign of the Lord's Supper ?

Answer.

Bread and Wine, which the Lord hath commanded to be received. ^{1 Cor. xi. 23-26.}

Question.

What is the inward part, or thing signified ?

Answer.

The Body and Blood of Christ, which are verily and indeed taken and received by the faithful in the Lord's Supper. <sup>1 Cor. x. 10.
John vi. 53, 47.</sup>

Question.

What are the benefits whereof we are partakers thereby ?

Answer.

The strengthening and refreshing of our souls by the Body and Blood of Christ, as our bodies are by the Bread and Wine. <sup>Ps. civ. 15.
John vi. 35, 51,
55, 56.</sup>

Question.

What is required of them who come to the Lord's Supper ?

Answer.

To examine themselves, whether they repent them truly of their former sins, stedfastly purposing to lead a new life; have a lively faith in God's mercy through Christ, with a thankful remembrance of his death; and be in charity with all men. <sup>1 Cor. xi. 28.
2 Cor. vii. 11.
Tit. ii. 11, 12.
Heb. x. 21, 22.
Col. i. 12-14.
Matt. v. 23, 24.
1 Cor. v. 7, 8.
xiii. 3-8, 13.</sup>

¶ *The Curate of every Parish shall diligently upon Sundays and Holy-days, after the second Lesson at Evening Prayer, openly in the Church instruct and examine so many Children of his Parish sent unto him, as he shall think convenient, in some part of this Catechism.*

¶ *And all Fathers, Mothers, Masters, and Dames, shall cause their Children, Servants, and Apprentices, (which have not learned their Catechism,) to come to the Church at the time appointed, and obediently to hear, and be ordered by the Curate, until such time as they have learned all that is here appointed for them to learn.*

¶ *So soon as Children are come to a competent age, and can say, in their Mother Tongue, the Creed, the Lord's Prayer, and the Ten Commandments; and also can answer to the other Questions of this short Catechism; they shall be brought to the Bishop. And every one shall have a Godfather, or a Godmother, as a Witness of their Confirmation.*

¶ *And whensoever the Bishop shall give knowledge for Children to be brought unto him for their Confirmation, the Curate of every Parish shall either bring, or send in writing, with his hand subscribed thereunto, the names of all such persons within his Parish, as he shall think fit to be presented to the Bishop to be confirmed. And, if the Bishop approve of them, he shall confirm them in manner following.*

in the twelfth century. The Homily just quoted (written about 1562) says, "the common description of a Sacrament, which is, that it is a visible sign of an invisible grace." The somewhat involved form of this answer may be made clearer by a paraphrase, as follows:—"I mean an outward and visible sign (ordained by Christ Himself) of an inward and spiritual grace given unto us. This outward sign was ordained by Christ, first,

as a means whereby we are to receive the inward grace, and, secondly, as a pledge to assure us of that inward grace;" for the grace cannot ordinarily be separated from the sign which Christ has ordained. For expositions of the doctrine of the Sacraments, see the Introductions to, and Notes on, the Offices for Holy Baptism and the Holy Communion.

AN

INTRODUCTION TO THE CONFIRMATION OFFICE.

FROM the earliest ages of the Christian Church, and in every part of it all over the whole world, until modern times, the rite of Confirmation has been considered essential to the full perfection of Christian life in those who have attained to years when they can discern fully between right and wrong. Nor have any Christians been ordinarily permitted by the Church to partake of the Holy Communion until after they had been confirmed.

The rite appears to have been administered at first by an Apostle or Bishop laying his hands on the head of the baptized person, but at a very early period the rite of unction was added. The Apostles St. Peter and St. John went down to Samaria to lay their hands on those who had been baptized by the Deacon Philip [Acts viii. 14-17]; "and they received the Holy Ghost," some new and special Gift being bestowed upon them by the Holy Ghost through that outward sign. In the same manner St. Paul laid his hands on the Ephesian disciples of St. John the Baptist as soon as they had been "baptized in the name of the Lord Jesus" [Acts xix. 6]. In the latter case, and probably also in the former, the Gift bestowed was accompanied by other gifts of miraculous powers; but these were clearly a special addition to the ordinary gift, and thus it was for the confirmation of previous Baptism that the Apostles administered the rite by the imposition of their hands. The anxious care of St. Paul for the administration of it to the Ephesians, appears also to have a parallel in that which he expressed to the Roman Christians, when he wrote to them, "I long to see you, that I may impart unto you some spiritual gift, to the end ye may be established" [Rom. i. 11].

The rite so administered has several names given to it in the New Testament. The most obvious is that derived from the particular ceremony which was used in administering it, as when in the Epistle to the Hebrews "the doctrine of Baptisms and of laying on of hands" [Heb. vi. 2] is spoken of. Another title given to it is that of the Seal or the Sealing, as when St. Paul writes to the Ephesians, "After that ye believed in Christ, ye were sealed with that Holy Spirit of promise, which is the earnest of our inheritance" [Eph. i. 13, 14]: or, "Grieve not the Holy Spirit, whereby ye are sealed unto the day of redemption" [Eph. iv. 30]: or, again, "He which stablisheth us with you in Christ, and hath anointed us, is God; Who hath also sealed us, and given the earnest of the Spirit in our hearts" [2 Cor. i. 21]. There seems also to be a reference to the same ordinance in the words, "The foundation of God standeth sure, having this seal, The Lord knoweth them that are His: and, Let every one that nameth the name of Christ, depart from iniquity" [2 Tim. ii. 19]. By all which passages, where the idea of sealing is connected with the gift of the Holy Ghost, we are carried back to the same idea in respect to our Blessed Lord, of Whom it is said, "For Him hath God the Father sealed" [John vi. 27]. As all grace flows down from the Father to the members of Christ through Christ their Head, so from Him to Whom the Father "gave not the Spirit by measure," flows down, even to the "skirts of His" mystical "clothing," that anointing Spirit of promise, whereby Christians are "sealed unto the day of redemption." The Oriental Church, which is so conservative of Scriptural terms and language, still retains the name of the Seal or the Gift of the Holy Ghost, as that of the ordinance which the Western Church calls Confirmation.

The rite is also called "the Unction" or "Anointing," in the New Testament, and in this case also the name is clearly connected with our Lord, the Christ or Anointed One: the "holy Child Jesus, Whom Thou hast anointed" of Acts iv. 27, and of Whom St. Peter said, "how God anointed Jesus of Nazareth with the Holy Ghost, and with power" [Acts x. 38]. In a passage already quoted, St. Paul speaks of God having "anointed us" [2 Cor. i. 21]. St. John refers to it as a special means of illumination and union with Christ: "But the anointing which ye have received of Him abideth in you: and ye need not that any man should teach you: but as the same anointing teacheth you of all things, and is truth, and is no lie, and even as it hath taught you, ye shall abide in Him" [1 John ii. 27]. He also says of it, "Ye have an unction from the Holy One, and ye know all things" [1 John ii. 20]: and these words respecting illumination at once connect themselves with those of our Lord respecting the Holy Ghost the Comforter, "He shall teach you all things" [John xiv. 26].

The familiar name by which this rite is known in the Western Church appears first in the writings of St. Ambrose,—“Ye have received the spiritual seal. . . . God the Father hath signed you, Christ our Lord hath confirmed you, and, as ye are taught by the apostolic lection, hath given you the pledge of the Spirit in your hearts” [Ambros. de Myst. vii. 42]. By the time of St. Gregory, the name seems to have been commonly established, although it still continued to be called "signaculum" and "chrisma."

In the early Church, when Baptism was publicly administered at special seasons, and in the presence of the Bishop, the baptized were confirmed immediately on leaving the font. In his Treatise concerning Baptism, Tertullian says: "After this, having come out from the bath, we are anointed thoroughly with a blessed unction. . . . Next to this, the hand is laid upon us, calling upon, and inviting the Holy Spirit, through the blessing" [Tert. de Bapt. vii. viii.]. St. Cyprian writes, in his famous seventieth Epistle, "Anointed also must be of necessity he who is baptized, that having received the chrism, that is, unction, he may be the anointed of God, and have within him the grace of Christ" [Ep. lxx. 3]. Again, expounding the passage in the Acts respecting the Confirmation of the Samaritans by St. Peter and St. John, he says, "Which now also is done among us, those baptized in the Church being brought to the Bishops of the Church, and by our prayer, and laying on of hands, they receive the Holy Ghost, and are perfected with the seal of the Lord" [Ep. lxxiii. 8]. Some passages in which St. Cyril speaks of the use of the chrism after Baptism, will be found in the Introduction to the Baptismal Offices: he also says to those about to be baptized, "In the days of Moses, the Spirit was given by the laying on of hands, and Peter also gives the Spirit by the laying on of hands. And on thee also, who art about to be baptized, shall His grace come" [Catech. Lect. xvi. 26].

This administration of Confirmation at the time of Baptism is provided for in the Sacramentaries of Gelasius and St. Gregory. The following is the form which has been handed down from that distant time, beginning with the Rubric which follows the Baptism:—

“ Pontifex vero redit in sacrarium expectans, ut cum vestiti fuerunt infantes, confirmet eos. Qui etiam non prohibentur

lactari ante sacram Communionem, si necesse fuerit. Induti vero, ordinantur per ordinem sicut scripti sunt. Et infantes quidem in brachiis dextris tenentur: majores vero pedem ponunt super pedem patris sui. Deinde Schola jussa facit Letaniam quinam ad fontes, Pontifex vero veniens ad infantes, tenente Archidiacono chrismate, involutis scapulis et brachiis ex panno lineo, et levata manu sua super capita omnium dicit. Omnipotens sempiternus Deus, qui regenerare dignatus es . . . [As in the right-hand column in the Office beyond.]

"Et interrogantibus Diaconibus nomina singulorum, Pontifex tincto pollice in chrismate, facit crucem in fronte unius, similiter per omnes singillatim." [Menard's Sac. Greg. 73.]

In later days, Baptism and Confirmation were separated, the latter being administered, as now, by the Bishop, in periodical visits to the greater churches: but the form of the rite has varied very little since the days of St. Gregory. Bede narrates of St. Cuthbert [A.D. 686], that he used to go round his diocese bountifully distributing counsels of salvation, "as well as laying his hands on the lately baptized, that they might receive the grace of the Holy Ghost" [Life of St. Cuthbert, xxix.]: and from a period very little later, a Pontifical has come down to us which belonged to Egbert, Archbishop of York, and which contains the form of Confirmation, as it was then used; probably the same that was used by St. Cuthbert. A translation of it is here given, as it forms a link between the primitive office of St. Gregory, and that of the Mediæval Church, from which our own is directly derived.

§ *The Use of York. Circ. A.D. 700.*

"The Confirmation of men, to be spoken by a Bishop.

"How he ought to Confirm.

"Almighty, everlasting God, who hast vouchsafed to regenerate this Thy servant with water and the Holy Ghost, and Who hast given unto him remission of all his sins, pour into him, O Lord, the sevenfold Spirit, Thine holy Comforter, from heaven. Amen. Give him the Spirit of wisdom and understanding. Amen. The Spirit of counsel and strength. Amen. The Spirit of knowledge and piety. Amen. Fill him with the Spirit of the fear of God, and of our Lord Jesus Christ, and of Thy favour: sign him with the sign of Thy holy cross unto eternal life.

"Here he ought to put the chrism on the forehead of the man, and say—

"Receive the sign of the holy cross, by the chrism of salvation, in Jesus Christ unto eternal life. Amen.

"The Lord be with you.

"And with thy Spirit.

"The peace and blessing of the Lord be ever with thee. And with thy Spirit.

"Afterwards, he ought to read this prayer—

"God the Father, and the Son, and the Holy Ghost, confirm thee, that thou mayest have eternal life; and thou shalt live for ever? So thus let every man be blessed that feareth the Lord. The Lord from out of Zion bless thee, and mayest thou see the things which are good in Jerusalem all the days of thy life. Peace be with thee unto eternal life. Amen.

"Then they are to be bound [with a band of linen round the forehead].

"O God, who gavest the Holy Ghost to Thy Apostles, and willedst Him to be given to the rest of the faithful by them and their successors, look favourably upon our humble service, and grant unto all them whose forehead we have this day anointed and confirmed with the sign of the cross, that the Holy Ghost coming upon their hearts may perfect them for a temple of His glory, by worthily inhabiting them. Through.

"Then they are to be communicated of the sacrifice.

"The episcopal benediction follows.

"God Almighty, who created all things out of nothing, bless you, and grant you in baptism and in confirmation remission of all sins. Amen.

"And may He who gave the Holy Ghost in fiery tongues to

His disciples, enlighten your hearts by His own enlightening, and duly kindle them to the love of Himself. Amen.

"So that, being cleansed from all vices, defended by His own assistance from all adversities, we may be worthy to be made His temple. Amen.

"May He who created you guard you from all imminent evils, and defend you from all wickedness. Amen.

"Which He Himself. Amen. The blessing. Amen.

"Another blessing at mass, after confirmation—

"Four forth, O Lord, we pray Thee, Thy heavenly blessing upon these Thy servants, and Thine handmaids, to whom Thou hast been pleased by us to deliver Thine excellent sevenfold Holy Ghost, and to give them the grace and gifts of the Holy Ghost. Amen.

"That whosoever are born again of water and the Holy Ghost may be ever defended by Thy protection. Amen.

"May charity, diffused by the Holy Ghost, abound in them, which covers and overcomes every multitude of sins. Amen.

"Protect them with divine protection, that all sins may flee from them; and may they always study to fulfil Thy commandments. Amen.

"Rest favourably in them, Who formerly rested glorious in the Apostles.

"Which He Himself. Amen. The blessing. Amen."

These specimens of Confirmation Offices of the Western Church, will show how little substantial variation there has been in them from the days of Primitive Christianity down to our own time. In the Eastern Church the rite is not restricted to the Bishop, but is administered by the priest (as his deputy, and with Chrism blessed by him) immediately after Baptism, with the sign of the cross in chrism on various parts of the body, and the words, "The Seal of the gift of the Holy Ghost. Amen." The modern Roman is almost identical with the ancient use of Salisbury.

The imposition of hands was undoubtedly the principal ceremony of Confirmation in Apostolic times, and cannot be regarded otherwise than as the essential part of the rite. Nor can it be doubted, that it consisted of an actual placing of one or both of the Bishop's hands on the head of the person to be confirmed. Yet, in mediæval times (as in the modern Latin Church), consignation with chrism, and the blow on the cheek, were the only ways in which the Bishop's hand came into actual contact with the head of the candidate; and what was called *imposition* of hands, was an *elevation* of his hands in an attitude of benediction, spreading them abroad towards the persons kneeling before him. A somewhat similar custom has been adopted by modern English bishops, who lay their hands on each child successively, and then say the words, "Defend, O Lord," &c., over the whole collectively with hands outstretched. Yet the actual laying on of hands is perfectly effected in the latter case, and it is certain that the words are not an essential part of the rite¹. The words of the English Rubric, however, plainly direct that the words shall be uttered over each child while the hands of the Bishop rest upon him; and as the words are a precatory benediction, it does appear, that the other custom may, in some degree, deprive the person who ought to be individually blessed by the Bishop, of the full benefit which the blessing is intended to convey.

Confirmation is not, according to the strictest form of definition, a Sacrament. Our Lord did indeed ordain "the outward and visible sign" of benediction, by laying His hands on the little children who were brought to Him, and on His Apostles. But there is no distinct evidence that this laying on of hands was for the purpose of Confirmation; and as Baptism, in its fullest Christian phase, was not administered before the Day of Pentecost, it can scarcely be supposed that such was the case. Although, however, not a Sacrament in the strictest sense, Confirmation undoubtedly conveys grace, and the grace is conveyed by the outward sign. Accordingly Bishop Cosin writes, "The nature of this holy Sacrament (for so we need not fear to call it in a right sense) will be more easily understood . . ." [Works, v. 142], giving it

¹ One of the oldest Bishops in the Church of England confirmed 12,564 persons during the summer of 1865. To say the words over each severally in such a multitude seems almost impossible.

the sacred title in a subordinate sense, as an outward and visible sign of an inward and spiritual grace indeed, but not known to be certainly of Christ's Institution, nor "generally necessary for salvation."

§ *The Effect of Confirmation.*

The outward sign of Confirmation is the same as that of Ordination, the laying on of hands by a Bishop; and this fact suggests that there is some analogy between the two rites. Confirmation is, indeed, a kind of lesser Ordination, by which the baptized person receives the gift of the Holy Ghost for the work of adult Christian life: and hence it is the means of grace by which that "priesthood of the laity" is conferred, to which St. Peter refers when he writes, "Ye are a chosen generation, a royal priesthood, an holy nation, a peculiar people" [1 Pet. ii. 9]. It is also the means of grace by which the Christian, whose sins were all forgiven in Baptism, receives a further measure of strength, enabling him to stand against the temptations which assail mature life. Thus, although Baptism is a perfect Sacrament, conveying forgiveness of sin, and giving a new nature through the union which it effects between the baptized and Christ, yet Confirmation is the complement of Baptism, in that it (1) renews and strengthens the Christian life then given, and (2) carries the baptized person on to "perfection," so that he becomes competent to take part in the highest of Christian ordinances. And thus, as grace for the work of the ministry is given by the laying on of hands in Ordination,—the ordained person being placed in a different relation towards God from that which he before occupied—so by the laying on of hands in Confirmation the relation of the confirmed person towards God is also changed, and he becomes competent to undertake spiritual work, both as to duties and privileges, for which he was not previously qualified.

The value of this holy ordinance as a means of grace, and its relation to Baptism, are plainly and beautifully set forth in these words, taken from a book of Homilies written before the Reformation, and here transcribed from Fothergill's MS. Annotations on the Prayer Book, preserved in York Minster Library:—"In Baptism he was born again spiritually to live, in Confirmation he is made bold to fight. There he received remission of sin, here he receiveth increase of grace. There the Spirit of God did make him a new man, here the same Spirit doth defend him in his dangerous conflict. There he was washed and made clean, here he is nourished and made strong. In Baptism he was chosen to be God's son, and an inheritor of His heavenly kingdom: in Confirmation God shall give him His Holy Spirit to be his Mentor, to instruct him and perfect him, that he lose not by his folly that inheritance which he is called unto. In Baptism he was called and chosen to be one of God's soldiers, and had his white coat of innocency delivered unto him, and also his badge, which was the red cross, the instrument of His passion, set upon his forehead and other parts of his body: in Confirmation he is encouraged to fight, and take the armour of God put upon him, which be able to bear off the fiery darts of the devil, and to defend him from all harm; if he will use them in his battle, and not put himself in danger of his enemies by entering the field without them¹."

Such being the benefits to be derived from Confirmation, the Church has provided that it shall be administered so frequently that it may be within the reach of every one. The Sixtieth Canon enjoins that it shall be performed every third year, as follows:—

CANON 60.

"Confirmation to be performed once in three Years.

"Forasmuch as it hath been a solemn, ancient, and laudable

¹ Fothergill's MSS., xi. F. 9, p. 19. The first part of this quotation seems to be from Melchisedes, Epist. ad Hisp. in med., but Fothergill appears to have taken it from a book of English Homilies similar to the Liber Festivalis.

custom in the Church of God, continued from the Apostles' times, that all Bishops should lay their hands upon children baptized, and instructed in the Catechism of Christian Religion, praying over them, and blessing them, which we commonly call *Confirmation*, and that this holy action hath been accustomed in the Church in former ages to be performed in the Bishop's visitation every third year; we will and appoint, That every Bishop or his Suffragan, in his accustomed visitation, do in his own person carefully observe the said custom. And if in that year, by reason of some infirmity, he be not able personally to visit, then he shall not omit the execution of that duty of Confirmation the next year after, as he may conveniently."

But there are few dioceses in England in which the Bishop does not now find it necessary to hold Confirmations more frequently².

The age at which children are to be presented to the Bishop is not explicitly ordered by the Church of England; but the Sixty-first Canon makes it necessary for the child to have arrived at an age when he can have some intelligent acquaintance with the principles of faith and duty³.

CANON 61.

"Ministers to prepare Children for Confirmation.

"Every Minister, that hath cure and charge of souls, for the better accomplishing of the orders prescribed in the Book of Common Prayer concerning Confirmation, shall take especial care that none shall be presented to the Bishop for him to lay his hands upon, but such as can render an account of their faith, according to the Catechism in the said Book contained. And when the Bishop shall assign any time for the performance of that part of his duty, every such Minister shall use his best endeavour to prepare and make able, and likewise to procure as many as he can to be then brought, and by the Bishop to be confirmed."

The rubrics at the end of the Catechism further direct that *as soon as* this age of intelligence has been attained, children shall be brought to the Bishop to be confirmed. A further light is thrown upon the subject by the old rubric, out of which the present Preface to the Confirmation Office was formed. It may also be added that the 112th Canon requires all persons to become communicants before the age of sixteen years: and that with triennial confirmations this supposed many to become so at twelve or thirteen years of age. Before that age they were forbidden to communicate by one of Queen Elizabeth's Injunctions: the time for Confirmation, as intended by those who framed our present Office, appears therefore to have been from twelve to sixteen years of age, according to the development of intelligence on the one hand, and the opportunities offered, on the other, for coming to the ordinance. Yet the principle of the ordinance seems to suggest, that an earlier age even than twelve might often be adopted with great spiritual advantage to those who thus receive the grace of God to protect them against temptation.

² It is to be feared that Confirmations were very much neglected by the Bishops from the Reformation until modern times. Bishop Cosin has a note which shows that a loose practice of mediæval times prevailed even in the seventeenth century: "The place whereunto the children shall be brought for their confirmation is left to the appointment of the Bishop. If the place were ordered here to be none but the church, and there the office to be done with the Morning or Evening Prayer annexed, it would avoid the offensive liberty that herein hath been commonly taken, to confirm children in the streets, in the highways, and in the common fields, without any sacred solemnity." [Works, v. 522.] This seems to show that the canonical periods of Confirmation were not observed, but any chance occasion taken advantage of by the people.

³ A similar rule was enjoined by the Council of Trent. See Catechism of Council of Trent, chap. iii., quest. 7. The time there marked out for Confirmation is between seven and twelve years of age.

Heb. vi. 2.

THE

ORDER OF CONFIRMATION,

OR LAYING ON OF HANDS UPON THOSE THAT ARE BAPTIZED AND COME TO YEARS OF DISCRETION.

¶ Upon the day appointed, all that are to be then confirmed, being placed, and standing in order, before the Bishop; he (or some other Minister appointed by him) shall read this Preface following.

Acts viii. 14. 17.
xix. 6.

TO the end that Confirmation may be ministered to the more edifying of such as shall receive it, the Church hath thought good to order, That none hereafter shall be Confirmed,

CONFIRMATIO Salisbury Use.

PUERORUM ET ALIORUM BAPTIZATORUM.

¶ To the end that confirmation may be ministered to the more edifying of such as shall receive it, (according to St. Paul's doctrine, who teacheth that all things should be done in the church to the edification of the same,) it is thought good that none hereafter shall

Rubric in Common Prayer Book of 1549.

THE ORDER OF CONFIRMATION.

Previously to the last revision of the Prayer Book, in 1661, Confirmation was preceded by such questions from the Catechism as the Bishop saw fit to ask, or to cause to be asked. The Versicles and Collect followed, without any address or other questions intervening, and then the act of confirmation. As soon as the act of Confirmation had taken place, the Collect which now comes after the Lord's Prayer followed immediately, and the service concluded with the Blessing. In what respect this form of the Office differed from that of 1549 is shown further on.

The present form is due to Bishop Cosin, but he proposed even greater alterations, as will be seen in the following Office, copied from the margin of the Prayer Book which he prepared for the Revision Committee of 1661. He altered the title to its present form from the sub-heading, "Confirmation, or laying on of hands," and erased altogether the principal title which preceded the above rubric and included the Catechism. Under the new title he then inserted the following rubric and office:—

§ Order of Confirmation proposed by Bishop Cosin.

¶ Upon the day appointed, after Morning or Evening Prayer is ended, the Bishop shall go to the Lord's Table, and all that are to be then confirmed being placed, and standing in order before him near unto the same, he, or his chaplain, or some other Minister appointed by him, shall read this preface following.

"To the end that Confirmation, &c. [as before the Catechism usque ad] to the will of God.

"Answer me therefore, Do ye here in the presence of God, and of His holy Church, renew the solemn promise and vow that was made in your name at your Baptism, ratifying and confirming the same in your own persons, and acknowledging yourselves

bound to do all these things which your Godfathers and Godmothers then undertook for you?

"And every one shall audibly answer,

"I do.

"Minister.

"Dost thou renounce the devil and all his works, the vain pomp and glory of the world, with all the covetous desires of the same, and the wicked desires of the flesh, so that thou wilt not follow nor be led by them?

"Answer.

"I renounce them all.

"Minister.

"Do you believe in God the Father Almighty, &c. [as in Public Baptism usque ad] grace so to do¹?

"Minister, or the Bishop.

"Almighty God, Who hath given you the will to promise and undertake all these things, grant you also power and strength to perform the same, that He may accomplish the good work which He hath begun in you, through Jesus Christ our Lord. Amen.

¶ Then shall they all kneel, and the Bishop standing at the Lord's Table shall proceed, and say,—

[Then follow the Versicles and the Collect.]

¶ Then shall the Chaplain or Curate of the place read the Epistle—

"Acts viii. v. 12 to the 18 v.

¹ There appears to have been some confusion in Cosin's mind, when he wrote this, between the Office for Public Baptism and the Catechism, in which are the words, "I pray unto God to give me His grace, that I may continue in the same unto my life's end."

but such as can say the Creed, the Lord's Prayer, and the Ten Commandments; and can also answer to such other Questions, as in the short Catechism are contained: which order is very convenient to be observed; to the end that children, being now come to the years of discretion, and having learned what their Godfathers and Godmothers promised for them in Baptism, they may themselves, with their own mouth and consent, openly before the Church, ratify and confirm the same; and also promise, that by the grace of God they will evermore endeavour themselves faithfully to observe such things, as they, by their own confession, have assented unto.

Deut. vi. 7.
Ps. lxxviii. 1-7.

be confirmed but such as can say, in their mother tongue, the articles of the faith, the Lord's Prayer, and the Ten Commandments, and can also answer to such questions of this short catechism as the bishop (or such as he shall appoint) shall, by his discretion, appose them in. And this order is most convenient to be observed for divers considerations.

¶ *First, because that when children come to the years of discretion, and have learned what their godfathers and godmothers promised for them in baptism, they may then themselves, with their own mouth, and with their own consent, openly before the church, ratify and confess the same; and also promise that, by the grace of God, they will evermore endeavour themselves faithfully to observe and keep such things as they, by their own mouth and confession, have assented unto.*

[ratify and confirm, 1552.]

¶ *Secondly, forasmuch as confirmation is ministered to them that be baptized, that, by imposition of hands and prayer, they may receive strength and defence against all temptations to sin, and the assaults of the world and the devil, it is most meet to be ministered when children come to that age, that partly by the frailty of their own flesh, partly by the assaults of the world and the devil, they begin to be in danger to fall into sin.*

[into sundry kinds of sin, 1552.]

¶ *Thirdly, for that it is agreeable with the usage of the church in times past, whereby it was ordained that confirmation should be ministered to them that were of perfect age, that they, being instructed in Christ's religion, should openly profess their own faith, and promise to be obedient unto the will of God.*

¶ *And that no man shall think that any detriment shall come to children, by deferring of their confirmation, he shall know for truth that it is certain, by God's word, that children being baptized (if they depart out of this life in their infancy) are undoubtedly saved.*

[have all things necessary for their salvation, and be, 1552.]

“And the Gospel—

“St. Luke ii. v. 40 to the end of the chapter.”

[The remainder of the Office is the altered form which is now in use.]

From this Office, the basis of that now in the Prayer Book, it will be seen that the present question asked by the Bishop, “Do ye here,” &c., is the last relic of the public catechizing which was introduced into the Confirmation Service at the Reformation¹. This is made still more clear by a previous alteration which Cosin had made (and afterwards erased) in the rubric, which he turned into the present preface: after the words, “None shall hereafter be confirmed, but such as,” in the first paragraph, he had written, “the ministers of the several parishes

¹ The idea of introducing a Catechism into the Confirmation Service appears to have been taken from Archbishop Hermann's “Consultation.” For some notice of that provided by him for the purpose, see the Introduction to the Catechism.

having first instructed and examined them in the Catechism following, and shall certify and undertake for them, that they can say in their mother tongue,” &c. Cosin, therefore, shortened the Service by substituting an actual verbal renewal of the baptismal vows for the repetition of the Catechism; and it was afterwards still further shortened by retaining only the first of the questions which he proposed: in answering which the Candidates do still *implicitly* renew their baptismal vows.

The Latin in the right-hand page beyond represents the Confirmation Office as it stood in the old Manuals and Pontificals of the Church of England before the Reformation: the portion now discontinued being enclosed within brackets.

ratify and confirm] It will be observed that this originally stood “ratify and confess,” the word “confess” being used in the sense now more commonly expressed by the cognate word “profess.” The alteration was made in 1552, and seems to have been introduced out of pure love for a synonym. The phrase was adopted by Cosin in the subsequent question asked by the

¶ *Then shall the Bishop say,*

Deut. xxix. 9—
13.
2 Chron. xxxiv.
30—32.

DO ye here, in the presence of God,
and of this congregation, renew
the solemn promise and vow that was
made in your name at your Baptism ;
ratifying and confirming the same in
your own persons, and acknowledging
yourselves bound to believe, and to do,
all those things, which your Godfathers
and Godmothers then undertook for
you ?

¶ *And every one shall audibly answer,*

Exod. xxiv. 3. 7.
Deut. xxvii. 17, 18.

I do.

The Bishop.

Ps. cxxiv. 8.

OUR help is in the Name of the
Lord ;

Answer.

Ps. cxxi. 1, 2.

Who hath made heaven and earth.

DOETH that please the, then, and
doest thou allowe it, and wilt
thou continue in the same, that thy
godfathers promised and professed in
thy name at holy baptisme, when in thy
steede thei renounced Satan, and the
world, and bound the to Christe and to
His congregation, that thou shouldest
be thorowlie obedient to the Gospel ?

Answer. I allowe these things, and by
the healpe of our Lorde Jesus Christ I
wyl continue in the same unto thende.

[Daye's transl.
of Herman's
Consultation,
A.D. 1547.]

In primis dicat Episcopus.

Salisbury Use.

ADJUTORIUM nostrum in no-
mine Domini.

Qui fecit cœlum et terram.

Bishop, and its exact force may be determined by a parallel passage in the Declaration prefixed to the XXXIX Articles, in which the King is made to say, ". . . the Articles . . . which we do therefore ratify and confirm . . ." This declaration was first issued by Charles I. some time between June 26th and January 20th, 1627-8. It was just at this time that Cosin was so much in the King's confidence as to be commissioned to draw up the "Private Devotions" for his Majesty's use; and it is not improbable that the Declaration itself was also drawn up by Cosin.

The use of the expression "ratify and confirm" being thus illustrated, it may be added that the ratification and confirmation spoken of is *that of the Baptismal vows*. The confirmation of the Baptism itself, and therefore of the baptized person, is a wholly distinct thing, performed by the Bishop, and having no essential connexion whatever with the previous ratification of the Baptismal vow by the person confirmed. The confusion of terms is unfortunate, as many have been misled by it into a total misapprehension of the nature of Confirmation. A person is spiritually competent to receive Confirmation who has been baptized in private, or even by a layman: and for whom no Baptismal vows have ever been made.

endeavour themselves] This reflexive form of the verb "endeavour" has passed out of ordinary use. It occurs, however, five times in the Prayer Book, and also in the fourth clause of the Elizabethan Act of Uniformity. The other places where it is used in the Prayer Book are the Collect for the second Sunday after Easter, in two Answers made by Deacons and Priests respectively at their Ordination, and in the last clause but one of the Exhortation to those about to be ordained priests. Other illustrations of its use abound in the writings of the period, as when in the first part of the Homily against Contention [A.D. 1547] it is said, "Let us endeavour ourselves to fulfil St. Paul's joy;" and in Udall's translation of the paraphrase of Erasmus [A.D. 1548], "Those servants . . . do still endeavour themselves to do their office" [Mark, fol. 87]; and again, "Endeavour yourselves earnestly to be such as ye would be taken for" [Luke, fol. 112].

The MS. of a Confirmation address in Bishop Cosin's own handwriting is inserted between the leaves of the Office in his Durham Prayer Book. He appears to have used it *before* the Preface, "To the end therefore, &c.," being written at the close as its continuation. This address will be found printed at

p. 526 of the fifth volume of his works, and also in Nicholls' additional notes; but in neither of them have the Editors taken any notice of the indication afforded by the MS. respecting the manner in which the Bishop's address and the "preface" were intended by Cosin to be connected together. In adopting this Prefatory address, Cosin may have had in view the rubric of the Lyons Pontifical, in which the Bishop is directed to "first give an admonition to the people" respecting confirmation in its relation to themselves and those about to receive it. An "admonition" is also directed in a pontifical of the Church of Catalonia [see Martene I. i. 18, for both], and it is probable that it formed part of the ancient Gallican rite.

I do] This short answer, taken in connexion with the question to which it is a reply, contains, as has been already shown, an implicit renewal of the Baptismal vows; and is a repetition, under more solemn circumstances, and to God's chief minister, of the answer in the Catechism, "Yes, verily; and by God's help so I will," to the question, "Dost thou not think that thou art bound to believe, and to do, as they have promised for thee?" The connexion of this latter solemn adjuration with the "I do" of the Confirmation Service is accidentally indicated by the first versicle, "Our help is in the Name of the Lord." Every time the answer in the Catechism has been repeated by the children catechized, they have ratified and confirmed in their own persons, and acknowledged themselves bound to believe and to do, all those things which their Godfathers and Godmothers undertook for them, i.e. promised on their behalf, at their Baptism. They now ratify and confirm those Baptismal vows in as solemn a manner as possible, not before their parish priest only, but before the Bishop, who is the highest spiritual officer of Christ on earth, and His chief ministerial representative. This preliminary catechizing is therefore a formality of a very significant character, and, although no essential part of the rite of Confirmation, is a preparation for it which ought not to be passed over lightly. It marks the last step in the pathway of Christian childhood; and, on the verge of Christian maturity, sounds the trumpet-call of Christian duty to those who have promised manfully to fight under Christ's banner against sin, the world, and the devil, and to continue His faithful soldiers and servants unto their lives' end. The last stone in the foundation of the Christian life is about to be laid, and sealed with God's signet in confirmation of His promises. It is a time to remember that although "the foundation of God standeth sure, having this seal, The Lord knoweth them that are His," there is a "reverse" as well as an

Bishop.
Ps. cxlii. 2. Blessed be the Name of the Lord;

Answer.
Ps. cvi. 48. Henceforth world without end.

Bishop.
Ps. cii. 1. Lord, hear our prayers.

Answer.
Ps. cxxx. 1, 2. Phil. iv. 6. And let our cry come unto thee.

The Bishop.
Let us pray.

1 Cor. vi. 11.
Tit. iii. 5.
1 John ii. 12.
Eph. iii. 14—16.
John xiv. 16, 17.
26.
1 Cor. xii. 4, 8, 11.
Isa. xlv. 24.
xi. 2, 3.
2 Pet. i. 5—7.
Heb. xii. 28.

ALMIGHTY and everliving God, who hast vouchsafed to regenerate these thy servants by Water and the Holy Ghost, and hast given unto them forgiveness of all their sins; Strengthen them, we beseech thee, O Lord, with the Holy Ghost the Comforter, and daily increase in them thy manifold gifts of grace; the spirit of wisdom and understanding; the spirit of counsel and ghostly strength; the spirit of knowledge and true godliness;

Sit nomen Domini benedictam.

Ex hoc nunc et usque in sæculum.

[Domine, exaudi orationem meam.

Et clamor meus ad te veniat.]
Dominus vobiscum.
Et cum spiritu tuo.

Oremus.

OMNIPOTENS sempiternæ Deus, Salisbury Use.
Græg. Gelas. Qui regenerare dignatus es hos famulos Tuos *vel* has famulas Tuas ex aqua et Spiritu Sancto, Quique dedisti eis remissionem omnium peccatorum: immitte in eos septiformem spiritum, Sanctum Paraclitum de cœlis. Amen.
Spiritus sapientiæ et intellectus, Amen.
Spiritus scientiæ et pietatis. Amen.
Spiritus consilii et fortitudinis.
✠ Amen,

“obverse” to the seal of Confirmation, and that it has another inscription, “Let every one that nameth the Name of Christ depart from iniquity” [2 Tim. ii. 19]. The new blessing confirms the promise of God made in Baptism: it also enforces again that obligation of faithful service from which the Christian can never become free.

Our help is in the Name] With the first four of these Versicles the Office of Confirmation anciently began. The latter two appear to have been added for the first time in 1552, when the *Dominus vobiscum* was placed after the act of Confirmation instead of before the Collect which preceded it. They are, however, found in very general use in ancient Offices, as they are in our own, and it is not improbable that some of our ancient Pontificals had them in this place. They are in the Offices for Holy Matrimony, the Churchoing of Women, and the Visitation of the Sick; and in 1661 they were placed after the *Veni Creator* in the Consecration of Bishops.

§ *The Prayer of Invocation.*

The Collect which follows the versicles is of primitive antiquity, being in the Sacramentaries of St. Gregory and Gelasius, and also in St. Ambrose’s Treatise on the Sacraments [ii. 3; iii. 7]; while its position and use indicate a still higher antiquity¹. It is extant in a pontifical of Egbert, Archbishop of York, dating from about A.D. 700, so that we know it has been used in the Church of England for at least 1150 years. Some similar Invocation of the Holy Spirit is found in all Confirmation Offices.

The first words of this solemn invocation offer a distinct recognition of the truth that there is “One Baptism for the remission of sins;” and although Confirmation has been separated from Baptism for ages, yet the Church has never wavered in the continued use of these words, being assured that God’s promises are always fulfilled; and that if His pardon ceases to be effected,

it is not through any deficiency in His Gift of regeneration, but from the obstacles placed by man in the way of its operation. The latter part of the Collect is based on a faithful appreciation of our Lord’s words, “I am the Vine, ye are the branches.” They who abide in the olive partake of the fatness of the olive. The anointing of the Head flows down upon the members, “even to the skirts of His clothing.” As the sevenfold Spirit rested upon our Lord and Saviour (according to the prophecy of Isaiah), after His Baptism in Jordan, so may those who have been united to Him by Baptism, hope for a participation in the gifts of the same Spirit through that rite by which their Baptism is confirmed, and their Christian nature matured.

The Puritans objected to this prayer, in 1661, in the following words: “This supposeth that all the children who are brought to be confirmed have the Spirit of Christ, and the forgiveness of all their sins; whereas a great number of children at that age, having committed many sins since their baptism, do show no evidence of serious repentance, or of any special saving grace; and therefore this confirmation (if administered to such) would be a perilous and gross abuse².” This was a reverent objection, but showed considerable ignorance of the theological principles on which the Offices of the Church are framed, as well as of the manner in which they are intended to be administered. The reply of the Bishops was short, but pointed and consistent with the principles of the Prayer Book: “It supposeth, and that truly, that all children were at their baptism regenerate by water and the Holy Ghost, and had given unto them the forgiveness of all their sins; and it is charitably presumed that notwithstanding the frailties and slips of their childhood, they have not totally lost what was in baptism conferred upon them; and therefore adds, ‘Strengthen them, we beseech Thee, O Lord, with the Holy Ghost the Comforter, and daily increase in them Thy manifold gifts of grace,’ &c. None that lives in open sin ought to be confirmed³.” A faithful certainty respecting God’s justice, mercy, and grace, mingled with a loving habit of

¹ It is also to be found, in more Oriental language, in the Confirmation Office of the Eastern Church. See Littledale’s Offices of the Eastern Church, pp. 26, 145.

² Cardy. Conf., p. 329.

³ Ibid., p. 358.

and fill them, O Lord, with the spirit of thy holy fear, now and for ever.
Amen.

Acts viii. 17. ¶ *Then all of them in order kneeling before the Bishop, he shall lay his hand upon the head of every one severally, saying,*

Ps. xx. 1, 2.
lxxxiv. 11.
lxxiii. 23, 24.
Acts xiii. 52.
Jude 24, 25.

DEFEND, O Lord, this thy child [or, *this thy servant*] with thy heavenly grace, that *he* may continue thine for ever: and daily increase in thy holy Spirit more and more, until *he* come unto thy everlasting kingdom.
Amen.

2 Thess. iii. 16. ¶ *Then shall the Bishop say,*
The Lord be with you.

Et imple eos *vel* eas spiritu timoris Domini. ✠ Amen.

[Et consigna eos *vel* eas signo sanctæ crucis ✠ confirma eos *vel* eas chrismate salutis in vitam propitiatus æternam.
Amen.

¶ *Et tunc episcopus petat nomen, et ungat pollicem chrismate: et faciat in fronte pueri crucem, dicens,*

CONSIGNO te *N.* signo crucis ✠ et confirmo te chrismate salutis. In nomine Patris, et Filii, et Spiritus Sancti. Amen.

Pax tibi.]

charitable doubt respecting the sins of individual Christians, pervades the whole of the Prayer Book.

§ *The Act of Confirmation.*

The original form of this, in the Prayer Book of 1549, was as follows:—

“*Minister* 1. Sign them, O Lord, and mark them to be Thine for ever by the virtue of Thy holy cross and passion. Confirm and strengthen them with the inward unction of Thy Holy Ghost mercifully unto everlasting life. Amen.

“*Then the Bishop shall cross them in the forehead, and lay his hand upon their head, saying,*

“*N.* I sign thee with the sign of the cross, and lay my hand upon thee, in the Name of the Father, and of the Son, and of the Holy Ghost. Amen.

“*And thus shall he do to every child, one after another. And when he hath laid his hand upon every child, then shall he say,*

“The peace of the Lord abide with you.

“*Answer.* And with thy spirit.”

If the use of unction was dropped in 1549, the consignation with the cross was thus retained. In 1552 the rubric and words with which the latter was given were omitted, and a precatory benediction founded on the preceding Collect was adopted as an accompaniment to the laying on of the Bishop's hands. But it is probable that the sign of the Cross was still used by our Bishops, for its use is defended as if it were a well-known custom in a Sermon by Edward Boughen, chaplain to Howson, Bishop of Oxford. This sermon was preached at the Bishop's first visitation, on September 27th, 1619, Confirmations at that time being part of the Episcopal Visitation. Boughen's words are as follows: “The cross, therefore, upon this or the like consideration, is enjoined to be used in Confirmation in the Book of Common Prayer set forth and allowed in Edward VI.'s reign. And I find it not at any time revoked: but it is left, as it seems, to the bishop's discretion to use or not to use the cross in confirmation.” No doubt this represents the feeling of many who were occupied at various times with the revision of the Prayer Book. It might be desirable to omit the mention of many things for the sake of relieving the consciences of persons to whom they were a burden; but such omission was not necessarily to bind those in whose eyes the things omitted were precious to a total disuse of primitive and holy ceremonies. Charity towards those who disliked ceremonies was not intended to exclude charity towards those who loved them; and the Prayer Book thus represented in many

¹ See p. 1, margin.

places the *minimum* of ceremonial usage customary in the Church of England, but left the *maximum* to be sought from tradition. As for the sign of the cross itself, the time seems to have passed away when any justification of its use in Divine Service needs to be given to educated and religious persons. It may, however, be added, that neither the use of that ceremony, nor of the words, whether in the old or the present Prayer Book, is any essential part of the acts of Confirmation. Whatever of a sacramental nature is contained in the rite is contained in the Divinely instituted ceremony of the laying on of hands; the contact of which with the head of the person to be confirmed has been always esteemed (even in the form of consignation) absolutely necessary to a true Confirmation. It was the desire to restore this ceremony to its full importance, and to enforce the proper use of it, which really led to the changes made in the Office in 1552².

² It will be observed that it was the custom (according to ancient practice) for the Bishop to confirm the children by name, until 1552. This custom gave rise to a power on the part of the Bishop to change the baptismal name for another if he saw fit. “Let priests take care that names which carry a lascivious sound be not given to children at their baptism, especially to those of the female sex: if they be altered, let them be by the bishops at confirmation.” [Johnson's Canons, ii. 277.] On this subject Lord Coke says, “If a man be baptized by the name of Thomas, and after, at his confirmation by the bishop, he is named John, his name of confirmation shall stand good. And this was the case of Sir Francis Gawdie, chief justice of the Court of Common Pleas, whose name by baptism was Thomas, and his name of confirmation Francis: and that name of Francis, by the advice of all the judges, he did bear, and afterwards used in all his purchases and grants.” [Coke's Institutes, I. iii.] Lord Coke must have been well acquainted with the practice of the bishops in confirming, and his words indicate either that (1) the rite of consignation was still retained by traditional usage, or that (2) Bishops named the persons confirmed by saying, “This thy child *N.*,” or “thy servant *N.*” Johnson, in speaking of the practice (in a note to the above Canon), expressly says that the practice of confirming by name was altered “upon the review of the Liturgy at King Charles' restoration,” but no Prayer Books are known which provide for this except that of 1549.

Bishop Kennett has left on record in some MS. notes to the Prayer Book, which are now in the British Museum, an account of a case in which a Bishop changed the name of a child so lately as 1707. He states the fact as follows:—“On Sunday, Dec. 21, 1707, the Lord Bishop of Lincoln confirmed a young lad in Henry VII.'s Chapel: who upon that ceremony was to change his Christian name: and, accordingly, the sponsor who presented him delivered to the Bishop a certificate, which his lordship signed, to notify that he had confirmed such a person by such a name, and did order the parish minister then present to register the person in the parish book under that name. This was done by the opinion under hand of Sir Edward Northey, and the like opinion of Lord Chief Justice Holt, founded on the authority of Sir Edward Coke, who says it was the common law of England.” The ancient *canon* law certainly only referred to such a change when the baptismal name was one of an improper kind, yet this may only represent a portion of the *common* law of the Church on the subject.

Answer.

Tim. iv. 22. And with thy spirit.

¶ *And (all kneeling down) the Bishop shall add,
Let us pray.*

OUR Father, which art in heaven,
Hallowed be thy Name. Thy
kingdom come. Thy will be done in
earth, As it is in heaven. Give us
this day our daily bread. And forgive
us our trespasses, As we forgive them
that trespass against us. And lead us
not into temptation; But deliver us
from evil. Amen.

¶ *And this Collect.*

Jer. x. 28.
1 Tim. v. 4.
Phil. ii. 13.
James iv. 6. v. 16.
Eph. iii. 5.
Acts viii. 14—17.
Ps. ciii. 13.
Ezra viii. 22.
2 Cor. vi. 17, 18.
John xiv. 16, 17.
2 Tim. iii. 15.
iv. 7, 8.
Jude 24, 25.

ALMIGHTY and everliving God,
who makest us both to will and
to do those things that be good and
acceptable unto thy divine Majesty;
We make our humble supplications
unto thee for these thy servants, upon
whom (after the example of thy holy
Apostles) we have now laid our hands,
to certify them (by this sign) of thy
favour and gracious goodness towards
them. Let thy fatherly hand, we be-
seech thee, ever be over them; let thy
Holy Spirit ever be with them; and
so lead them in the knowledge and
obedience of thy Word, that in the
end they may obtain everlasting life,
through our Lord Jesus Christ, who
with thee and the Holy Ghost liveth
and reigneth, ever one God, world
without end. *Amen.*

2 Cor. vi. 18.
Prov. iii. 6.
Heb. x. 16.
Ps. cxix. 32, 73.
Ps. xvi. 1. xxvii.
5. cxxi. 1—8.
2 Tim. iv. 18.

O ALMIGHTY Lord, and ever-
lasting God, vouchsafe, we be-
seech thee, to direct, sanctify, and
govern both our hearts and bodies, in
the way^s of thy laws, and in the works
of thy commandments; that, through
thy most mighty protection both here
and ever, we may be preserved in body
and soul, through our Lord and
Saviour Jesus Christ. *Amen.*

Oremus.

The Collect.

ALMIGHTY and merciful God,
heavenly Father, which only
workest in us to wil and to performe
the thynges that please The, and be
good in dede, we besech The for these
children, whom Thou hast gyven to
Thy church . . . that when we shall
now lay our handes upon them in Thy
name, and shall certifie them by thys
signe, that Thy Fatherly hande shall
ever be stretched forth upon them, and
that they shall never wante Thy holy
Spirite to keepe, leade, and governe
them in the way of healthe and in a
very christian life

Daye's transl.
of Herman's
Consultation,
A.D. 1547.

Oratio.

DEUS, Qui apostolis tuis Sanc-
tum dedisti Spiritum, Quique
per eos eorum successoribus cæterisque
fidelibus tradendum esse voluisti: re-
spice propitius ad nostræ humanitatis
famulatum: et præsta, ut horum corda
quorum frontes sacrosancto chrismate
delinivimus, et signo sanctæ crucis
consignavimus, idem Spiritus Sanctus
adveniens, templum gloriæ suæ dig-

Salisbury Use.

§ *The Collect and Benediction.*

The Lord's Prayer was first inserted in the Confirmation Service in 1661, when the *Dominus vobiscum*, which had been removed from the Service altogether in 1552, was replaced in its present position, instead of with the other versicles. The *Pax tibi* was also removed in 1552, but was not restored. This "Peace be with you" was (as in the modern Latin Church) accompanied by a slight blow on the cheek, intended to signify

that the person confirmed was to be a faithful soldier of Christ, and ready to suffer affronts for His sake.

The Collect which follows the Lord's Prayer has some likeness to that which occupied the same place in the ancient office, but its words are taken in part from a long Collect which preceded the Act of Confirmation in Archbishop Hermann's Cologne Book. The second Collect was inserted in 1661, probably with the intention of placing at the end of the Service a prayer for the general congregation, the preceding one being for the newly con-

THE ORDER OF CONFIRMATION.

nanter inhabitando perficiat. Per
Dominum. In unitate ejusdem.

ECCE sic benedicetur omnis homo, Salisbury Use.
qui timet Dominum. Benedicat
vos Dominus ex Sion: ut videatis bona
Hierusalem omnibus diebus vestris.

Numb. vi. 22—27. ¶ Then the Bishop shall bless them, saying thus,
2 Cor. xiii. 14.

THE Blessing of God Almighty,
the Father, the Son, and the
Holy Ghost, be upon you, and remain
with you for ever. *Amen.*

¶ *And there shall none be admitted to the holy
Communion, until such time as he be con-
firmed, or be ready and desirous to be con-
firmed.*

Benedicat vos Omnipotens Deus:
Pa^{ter}, et Fi^{lius}, et Spiritus^{us}
Sanctus. Amen.

... *Statuimus quod nullus ad sacramentum* Constit. iv., Abp.
corporis et sanguinis Domini admittatur Peckham, A.D.
1281.
*extra articulum mortis, nisi fuerit confirma-
tus, vel nisi a receptione confirmationis
rationabiliter fuerit impeditus.*

firm. The latter part of the ancient Benediction has been
retained in the English Office, but the fifth and sixth verses of
the 128th Psalm which preceded it were not continued in use.

The ancient benedictions in this place were sometimes very
long: and were, in reality, a Psalm pronounced in a benedictory
form.

THE FORM OF
SOLEMNIZATION OF
MATRIMONY.

¶ *First the Banns of all that are to be married together must be published in the Church three several Sundays, or Holydays, in the time of Divine Service, immediately before the sentences for the Offertory, the Curate saying after the accustomed manner,*

I PUBLISH the Banns of Marriage between *M.* of — and *N.* of —. If any of you know cause, or just impediment, why these two persons should not be joined together in holy matrimony, ye are to declare it. This is the first [*second, or third*] time of asking.

THE FORM OF SOLEMNIZATION OF MATRIMONY.

THE words of our Blessed Lord and of His Apostles respecting Marriage, gave it at once the stamp of a religious institution having the character of a mystery,—that is, in the wide sense of the word, a Sacrament: and, accordingly, the Church has always enjoined its celebration with ecclesiastical ceremonies and by ecclesiastical persons. Among the earliest of all Christian writings after the New Testament are the Epistles of St. Ignatius; and in one of these, which he wrote to St. Polycarp and the Church of Smyrna, as he was journeying onward to his martyrdom, he writes: "It is fitting for those who purpose matrimony to accomplish their union with the sanction of the Bishop; that their marriage may be in the Lord, and not merely in the flesh. Let all things be done to the honour of God." [Ignat. ad Polycarp. v.] Tertullian speaks of marriages being "ratified before God," and says afterwards, "How can we find words to describe the happiness of that marriage in which the Church joins together, which the Oblation confirms, the benediction seals, the angels proclaim when sealed, and the Father ratifies!" [Tertull. ad Ux. ii. 7, 8.] In the thirteenth canon of the fourth council of Carthage [A.D. 398] it is enjoined that the bride and bridegroom shall be presented by their parents and friends to a priest for benediction. St. Basil calls marriage a yoke which διὰ τῆς εὐλογίας, by means of the benediction, unites in one those who were two. [Basil, Hexaem. vii.] St. Ambrose calls marriage a sacrament, as does also St. Augustine in many places of his treatise "on the Good of Marriage:" and the former, again, says, "As marriage must be sanctified by the priest's sanction and blessing, how can that be called a marriage where there is no agreement of faith?" [Ambros., Ep. xix.] Lastly, to pass from the Fathers of the fourth century to our own land and to the tenth, there is among the laws of King Edmund [A.D. 946], respecting espousals, one which provides that "the priest shall be at the marriage, and shall celebrate the union according to custom with God's blessing, and with all solemnity." Our English Office, which is substantially

ORDO

Salisbury Use.

AD FACIENDUM SPON-
SALIA.

.... *Debet enim sacerdos banna in facie ecclesie infra missarum solemnia cum major populi adfuerit multitudo, per tres dies solemnes et disjunctas, interrogare: ita ut inter unum quemque diem solemnem cadat ad minus una dies ferialis et si contrahentes diversarum sint parochiarum, tunc in utraque ecclesie parochiarum illarum sunt banna interroganda*

the same as the old Latin one, is probably a fair representative of the one which was in use in that distant age.

§ *The Publication of Banns.*

It is reasonably supposed, from the manner in which Marriage is referred to by the primitive fathers, that some public notice was given to the Bishop, or to the assembled Church, equivalent to that now in use; and traces of such a practice have been observed in the French Church of the ninth century. The earliest extant canon of the Church of England on the subject is the eleventh of the Synod of Westminster, A.D. 1200, which enacts that "no marriage shall be contracted without banns thrice published in church" [Johnson's Canons, ii. 91]; but this seems only like a canonical enactment of some previously well-known custom. The existing law of the Church of England is very strict on the subject, as may be seen from the first part of the sixty-second Canon.

"CANON 62.

"Ministers not to marry any Persons without Banns or Licence.

"No Minister, upon pain of suspension *per triennium ipso facto*, shall celebrate Matrimony between any persons, without a faculty or licence granted by some of the persons in these our Constitutions expressed, except the Banns of Matrimony have been first published three several Sundays, or Holydays, in the time of Divine Service, in the Parish Churches and Chapels where the said parties dwell, according to the Book of Common Prayer. . . ."

The Licence is an Episcopal dispensation, permitting the marriage to take place without any previous publication of banns. Such licences have been granted by English bishops at least since the fourteenth century, and the power of granting them was confirmed by 25 Hen. VIII. c. 21. Marriages to be performed under an ordinary Licence are subject to the same restrictions in respect to time and place as those by Banns; but special Licences can be

¶ *And if the persons that are to be married dwell in divers Parishes, the Banns must be asked in both Parishes; and the Curate of the one Parish shall not solemnize Matrimony betwixt them, without a Certificate of the Banns being thrice asked, from the Curate of the other Parish.*

¶ *At the day and time appointed for solemnization of Matrimony, the persons to be married*

¶ *In primis statuatur vir et mulier ante ostium ecclesie coram Deo, sacerdote, et populo, vir*

granted by the Archbishop of Canterbury, which are not subject to these restrictions¹. Banns hold good for three months, and no longer, from the date of the last publication; and licences for the same time from the day on which they were granted.

The law respecting clandestine marriages is so very strict, and the consequences to any clergyman who performs the ceremony are so serious, that it may be well to state shortly what means are provided for guarding against them. [1] By Stat. 4 Geo. IV. c. 76, § 7, "no minister shall be obliged to publish banns, unless the persons shall *seven days at least* before the time required for the first publication deliver or cause to be delivered to him a notice in writing of their names, of their house or houses of abode, and of the time during which they have dwelt, inhabited, or lodged in such house or houses." The clergyman is not bound to demand this notice, but the power of doing so is given, that he may have opportunity of inquiring into the truth of the statements made respecting the alleged residence of the persons in his parish: and if after the marriage it is discovered that the persons were not so residing, and that the clergyman marrying them made no inquiry, he is liable to the full penalty of three years' suspension imposed by the Canon. [2] The rubric enjoins that where the persons whose banns are to be published reside in different parishes, they shall be married in one of them, and a certificate of the due publication of banns in the other shall be given to the clergyman required to marry them before he be allowed to perform the ceremony. [3] The sixty-second Canon forbids a clergyman, (under penalty of three years' suspension) to marry any persons by banns or licence except between the hours of eight and twelve in the morning, and in the Church.

"CANON 62.

"... Neither shall any Minister, upon the like pain, under any pretence whatsoever, join any persons so licensed in marriage at any unseasonable times, but only between the hours of eight and twelve in the forenoon, nor in any private place, but either in the said Churches or Chapels where one of them dwelleth, and likewise in time of Divine Service. . . ."

[4] The marriage of minors by banns is forbidden (under the same Canon and Statute of Geo. IV.) unless with the consent of parents or guardians.

"CANON 62.

"... Nor when banns are thrice asked, and no licence in that respect necessary, before the parents or governors of the parties to be married, being under the age of twenty and one years, shall either personally, or by sufficient testimony, signify to him their consents given to the said Marriage."

The eighth section of the Act, however, enacts that no clergyman shall be punishable for celebrating the marriage of minors without the consent of parents or guardians, unless he has had notice of their dissent. If such dissent is openly declared or caused to be declared, at the time of the publication of the banns, such publication becomes "absolutely void." Where a Licence is brought to the clergyman (however wrongfully obtained) he is not legally responsible.

In modern Prayer Books the rubric respecting the publication of Banns is seldom printed correctly. About the year 1809 the

Delegates of the press at Oxford [see Bishop of Exeter's Speech in Hansard, III. v. 78, p. 21] caused it to be altered in all the Oxford Prayer Books, so as to make it direct that the Banns shall be published after the Second Lesson at Morning or the Second Lesson at Evening Prayer, their object being to bring the rubric into agreement with 26 Geo. II. c. 33, s. 1. But that statute only provided for the publication to take place after the Second Lesson at Evening Prayer, in the absence of a Morning Service; and, according to the decision of Lord Mansfield and Baron Alderson, left the rubric untouched. In Reg. v. Benson, 1856, Sir Edward Alderson expressed a doubt whether the publication of Banns is valid under the Act of Parliament in question, when it has taken place after the second lesson instead of after the Nicene Creed. The law, said the judge, had not altered the injunction of the rubric. As, through the neglect of Bishops and Clergy in past times, Morning Service was not always celebrated, "the statute enacted that in such cases the publication should be made in the Evening Service after the Second Lesson." The Marriage Act of 1836 expressly confirms "all the rules prescribed by the rubric" in its first clause².

The limitation of the hours during which the celebration of Marriages may take place is partly to ensure publicity³. So in 1502 a priest was presented to the Archdeacon for marrying a man and woman "in hora secunda post mediam noctem, jannis clausis;" and in 1578 another was presented for marrying in the afternoon. [Hale's Precedents, 247. 507.] But it is conjectured with some reason, that the practice of morning marriages necessarily arose from the Office being followed by the Holy Communion. It is some confirmation of this, that the wedding breakfast is always eaten after the marriage, as if in obedience to the rule of not breaking the night's fast before Communion.

After the form of the Banns (which was inserted by him) Bishop Cosin proposed to print the following rubrics, which are written in the margin of his Durham Prayer Book:—

¶ The impediments of Marriage are Pre-contract; or a suit depending thereupon, Consanguinity, or Affinity within the degrees prohibited by the laws of God and this realm, Sentence of divorce from a party yet living, Want of competent years, Consent of parents in minors, and of Confirmation and such like.

¶ And none shall be married till their Banns be thrice thus published, unless a lawful dispensation to the contrary be procured: neither shall any persons under the age of twenty-one years complete be married without the express consent of their parents or guardians.

¶ No Minister shall celebrate any Marriage but publicly in the Parish Church or Chapel where one of the parties dwelleth; nor at other times than between the hours of eight and twelve in the forenoon.

¶ And here is to be noted that by the Ecclesiastical Laws of this Realm, there be some times in the year when Marriage is not ordinarily solemnized⁴.

At the day and time appointed for the solemnization of

² It has been doubted whether Banns published upon Holydays which are not Sundays would be considered legal, as Holydays are not mentioned, while Sundays are, in the Marriage Act, Geo. IV. 76; but the later Act seems to resolve the doubt, and the Latin rubric shows the rationale.

³ The provisions to secure publicity were very stringent in the mediæval Church of England. See Johnson's Canons, ii. 84. 91.

⁴ See note to Table of Vigils and Fasts, &c., for Cosin's list of these times.

¹ These Special Licences were originally a privilege of the Archbishop of Canterbury as "Legatus natus" of the Pope. The right to grant them is confirmed by the Marriage Act of 1836.

shall come into the body of the Church with their friends and neighbours: and there standing together, the man on the right hand, and the woman on the left, the Priest shall say,

a dextris mulieris, et mulier a sinistris viri.

* * * * *

¶ *Tunc interroget sacerdos banna dicens in lingua materna sub hac forma,*

[*Matrimony*] These words do not refer to the day, and time fixed for the particular marriage which is about to take place, but to the canonical periods of the year, and the canonical hours of the day during which Matrimony may be solemnized. Enough has been said respecting the hours of the day, but a few remarks may be added respecting the Canonical limitations as to the Ecclesiastical seasons for Marriage.

As early as the fourth century the Council of Laodicea [cir. A.D. 365] forbade, by its fifty-second canon, the celebration of Marriages during Lent. Durandus states the times as from Advent Sunday to the Epiphany, from Septuagesima to the Octave of Easter, the three weeks before the feast of St. John, and from the first day of the Rogations to the Octave of Pentecost inclusive. [Durand. I. ix. 7.] The Manual of Salisbury has a rubric on the subject as follows:—"¶ Et sciendum est quod licet omni tempore possint contrahi sponsalia, et etiam matrimonium quod fit privatim solo consensu: tamen traditio uxorum, et nuptiarum solemnitas certis temporibus fieri prohibentur: videlicet ab adventu Domini usque ad octavam Epiphaniæ: et a Septuagesima usque ad octavam Paschæ: et a Dominica ante Ascensionem Domini usque ad octavam Pentecostes. In octava die tamen Epiphaniæ licite possunt nuptiæ celebrari: quia non invenitur prohibitum, quamvis in octavis Paschæ hoc facere non liceat. Similiter in Dominica proxima post festum Pentecostes licite celebrantur nuptiæ: quia dies Pentecostes octavam diem non habet." After the Reformation an entry of the prohibited times was often made in the Parish Register; and inquiries on the subject are found in some Episcopal Visitation Articles. A Latin notice of this kind appears in the register-book of Dymchurch, in Kent, dated 1630; a rhyming English one, of the same tenour, in that of St. Mary, Beverley, dated Nov. 25, 1641. In that of Wimbish, in Essex, there is one dated 1666, of which the following is a copy:—

"The Times when Marriages are not usually solemnized.
From { Advent Sunday } until { 8 days after Epiphany.
 { Septuagesima } { 8 days after Easter.
 { Rogation Sunday } { Trinity Sunday."

A similar entry appears in the register-book of Hornby, in Yorkshire; and Sharpe, Archbishop of York, in a charge of 1750 names the prohibited times as then observed. They will sometimes also be found mentioned in old Almanacks, as if the practice still continued during the last century. Although there is no modern canon of the Church of England respecting these prohibited times, the consentient testimony of these various centuries will have great weight with those who would supply, by a voluntary obedience, the absence of a compulsory law, when the mind of the Church appears to be plain and clear.

[*into the body of the Church . . . and there standing*] The ancient rubric, as will be seen above, required this part of the Office to be said, *ante osium ecclesiæ*. This seems to mean the same as the *ad valvas ecclesiæ* of the first rubric in the Office for making a Catechumen [see Holy Baptism]. The porch was probably intended in both cases, not the exterior of the Church. It is clearly from the ancient rubric that the English one is derived; and it is also equally clear that "the body of the Church" means some portion of the Nave. Of this practice it is difficult to find any explanation, unless it be that the betrothal anciently took place some time previously to the marriage, and that the latter only was associated with the Holy Communion. This was the opinion of the Bishops at the Savoy Conference; for when the Puritans objected to the "change of place and

posture mentioned in these two rubrics," the Bishops replied, "They go to the Lord's Table because the Communion is to follow" [Cardw., Conf. 360]. Whatever may have been the origin of the custom, it is undoubtedly enjoined by the present rubric, and the rubric has been so carried out in many churches down to our own time. In Bishop Wren's "orders and directions for the diocese of Norwich," the ninth Injunction directs that immediately after the "close of the first service," the "marriage (if there be any) be begun in the body of the Church and finished at the table;" and the eleventh orders, "that they go up to the holy table at marriages at such time thereof as the rubric so directeth." At Broadwater, in Sussex, the custom was found existing in 1800 by a new Rector, who continued it for the fifty years of his ministry there. It has also continued to the present day in some Yorkshire, Lincolnshire, and Somersetshire churches, and doubtless in many others elsewhere. In our modern churches the open space in front of the choir screen seems to be the most proper place for the first part of the service; although, of course, any other and more convenient part of the nave would equally suit the words of the rubric.

[*with their friends and neighbours*] Marriages are always supposed to be celebrated in the face of the Church, and both the civil and the ecclesiastical laws have always been severe in reprobating any thing like secrecy in the performance of the rite. The sixty-second Canon even directs that the marriage shall take place in time of Divine Service, and an extract given above from Bishop Wren's Injunctions shows that such was the practice in his time. The words "in the face of this congregation" seem to signify the intention of the Prayer Book in 1661 to be the same as that of the Canon in 1603. By the Marriage Act witnesses are required to be present, and to sign the register; and although it is not expressly ordered that these shall be friends of the bridegroom or bride, it is certainly more conformable to the spirit of the enactment as well as to that of the Church that they should be so rather than strangers, or than the parish clerk and sexton impressed *sicco pede* for the purpose.

[*the man on the right hand*] The custom is to read this portion of the rubric (which was added by Bishop Cosin) in the sense of the ancient one placed by its side. Yet it would be more in conformity with ritual habit to suppose that "on the right hand" means on the right hand of the priest, as he faces the man and woman, his right hand then answering to the "dexter side" (as heralds would say) of the Altar. This was the Jewish custom, which may reasonably be supposed to have been followed by the early Christians; and it may also be remarked that the north side of the Church is that which is appropriated to the men when the sexes are divided. Such a position would receive a significant meaning from the beautiful Marriage Psalm of Solomon, "Upon thy right hand did stand the Queen in a vesture of gold" [Ps. xlv. 10]: for, as the selection of this psalm for Christmas Day shows, these words are written prophetically of "the mystical union betwixt Christ and His Church," which is "signified" by holy matrimony.

It is worthy of notice that in the later part of the ancient Sarum Service there is a rubric directing that "when the prayers are ended and all have gone into the presbytery, that is, to the south side of the Church between the Choir and the Altar, *the woman being placed on the right hand of the man, that is, between him and the Altar,*" the Service for the Holy Communion shall commence. After which the bride and bridegroom are to kneel in front of the altar *in the same order* while the pall is held over them, and also during their communion.

[*the Priest shall say*] The ancient rule of the Church was

¹ There is a much longer rubric to the same effect in the *Ordo Sponsalium* of the Salisbury Missal.

² Cardw. Doc. Ann. ii. 203, 204.

Acts x. 23.
Ps. lxxxix. 5, 7.
Ruth iv. 9, 10.
Heb. xiii. 4.
Gen. ii. 18, 21—24.
Eph. v. 22—33.
Matt. xix. 4, 5.
John ii. 1—3.
7—11.
Gen. vi. 1—5.
1 Cor. vii. 2.
1 Kings xi. 1—4.
Prov. xix. 4.

DEARLY beloved, we are gathered together here in the sight of God, and in the face of this congregation, to join together this man and this woman in holy Matrimony; which is an honourable estate, instituted of God in the time of man's innocency; signifying unto us the mystical union that is betwixt Christ and his Church; which holy estate Christ adorned and beautified with his presence, and first miracle that he wrought, in Cana of Galilee; and is commended of Saint Paul to be honourable among all men: and therefore is not by any to be enterprised, nor taken in hand, unadvisedly, lightly, or wantonly, to satisfy men's carnal lusts and appetites, like brute beasts that have no understanding; but reverently, discreetly, advisedly, soberly, and in the fear of God; duly considering the causes for which matrimony was ordained.

2 Cor. vi. 14, 15.
Gen. i. 27, 28.
Eph. vi. 4.

First, It was ordained for the procreation of children, to be brought up in the fear and nurture of the Lord, and to the praise of His holy Name.

1 Cor. vii. 2—5.
vi. 15.
1 John iii. 2, 3.

Secondly, It was ordained for a remedy against sin, and to avoid fornication; that such persons as have not the gift of continency might marry, and keep themselves undefiled members of Christ's body.

Gen. ii. 18.
Eccl. iv. 9, 10.
Eph. v. 33.
1 Cor. vii. 14.
Matt. xix. 3—6.

Thirdly, It was ordained for the mutual society, help, and comfort, that the one ought to have of the other, both in prosperity and adversity. Into which holy state these two persons present come now to be joined. Therefore if any man can shew any just

ECCE convenimus huc fratres coram Deo, et Angelis, et omnibus Sanctis ejus, in facie Ecclesiæ, ad jungendum duo corpora, scilicet hujus viri et hujus mulieris, *Hic respiciat sacerdos personas suas*, ut amodo sint una caro et duæ animæ in fide et in lege Dei, ad promerendam simul vitam æternam quidquid ante hoc fecerint. Admoneo igitur vos omnes, ut si quis ex vobis qui aliquid dicere sciat quare isti adolescentes legitime contrahere non possint, modo confiteatur.

LO bretheren we are comen here before God and his angels, and all his halowes, In the face and presence of our moder holy Chyrche, for to couple and to knyght these two bodyes togyder: that is to saye, of this man and of this woman. That they be from this tyme forthe, but one body and two soules in the fayth and lawe of God and holy Chyrche: For to deserue euerlastyng Lyfe, what someuer that they haue done here before . . . I charge you on Goddes behalfe and holy Chirche, that if there be any of you that can say any thyng why these two may not be lawfully wedded togyder at this tyme, say it nowe, outhur pryuely or appertly, in helpynge of your soules and theirs bothe.]

[York Use.]
[MS. Bibl. Reg.
2, a. XXI., A.D.
1408.]

[I warne you alle that yf there bee any of you whych wost owht by thys man and thys woman where fore they won nat lawfully kome to gedyr, knowleche ye hyt here now or never.]

Salisbury Use,
[Harl. MS., 873.]

that marriages should be celebrated "per presbyterum sanctis ordinibus constitutum." no change was made in this rule at the Reformation or subsequently, and there is not a shadow of authority for the celebration of the rite of marriage by Deacons. Chief Justice Tindal gave his opinion, and that of his brother judges, before the House of Lords on July 7, 1843, that it was the rule of the Church of England to require the ceremony to be performed by a priest; and it may fairly be doubted whether a marriage could be legally maintained which had only been performed by a deacon. From an ecclesiastical point of view it must be remembered that (1) The Marriage Office is especially one of Benediction; that (2) Benedictions are beyond the power of a deacon; that (3) The rubrics throughout contemplate the Minister of the Office as a Priest; and that (4) No authority to celebrate marriages is given, either in words or by implication, to the Deacon at his ordination or at any other time. The duty of celebrating marriages ought not to be imposed upon Curates in

their diaconate by their Rectors; and the laity should insist strongly upon being married by Priests, remembering that otherwise their marriages are probably illegal, while they certainly cannot receive the fulness of Benediction which the Church has provided for them in the Office except from a Priest or a Bishop. *like brute beasts that have no understanding*] These unnecessarily coarse words were erased by Cosin in his revised Prayer Book. He also re-inserted from the book of 1549 the words "that such as be married may live chastely in matrimony" before "keep themselves," &c., at the end of the third paragraph.

Therefore if any man can shew any just cause] These ancient words are equivalent (as the next rubric but one shows) to a fourth publication of Banns. They are exactly analogous to the admonition of the Bishop to the people at the Ordination of Deacons and Priests, and to a similar one used at the Confirmation of Bishops. As will be seen above, the Address is sub-

cause, why they may not lawfully be joined together, let him now speak, or else hereafter for ever hold his peace.

¶ *And also, speaking unto the persons that shall be married, he shall say,*

Matt. xxvi. 63.
xii. 36.
2 Tim. iv. 1.
Eccl. xii. 14.
Luke xii. 2.
Mark vi. 17, 18.
Ezra ix. 14. x.
2-5. 10-12.

I REQUIRE and charge you both, (as ye will answer at the dreadful day of judgement when the secrets of all hearts shall be disclosed,) that if either of you know any impediment, why ye may not be lawfully joined together in matrimony, ye do now confess it. For be ye well assured, that so many as are coupled together otherwise than God's Word doth allow are not joined together by God; neither is their matrimony lawful.

¶ *At which day of Marriage, if any man do allege and declare any impediment, why they may not be coupled together in matrimony, by God's Law, or the Laws of this Realm; and will be bound, and sufficient sureties with him, to the parties; or else put in a Caution (to the full value of such charges as the persons to be married do thereby sustain) to prove his allegation: then the solemnization must be deferred, until such time as the truth be tried.*

¶ *If no impediment be alleged, then shall the Curate say unto the man,*

Matt. xix. 4-6.
Eph. v. 28, 29.
1 Pet. iii. 7.
Eccl. ix. 9.
Mal. ii. 15, 16.
1 Cor. vii. 3-5, 10.

N. **W**ILT thou have this woman to thy wedded wife, to live together after God's ordinance in the holy estate of matrimony? Wilt thou love her, comfort her, honour, and keep her in sickness and in health; and, forsaking all other, keep thee only unto her, so long as ye both shall live?

¶ *Eadem admonitio fiat ad virum et ad mulierem, ut si quid ab illis occulte actum fuerit, vel si quid devoverint, vel alio modo de se noverint quare legitime contrahere non possint: tunc confiteantur.*

[ALSO I charge you both, and [York Use.] eyther be your selfe, as ye wyll answer before God at the day of dome, that yf there be any thyng done pryuely or openly, betwene your selfe: or that ye knowe any lawfull lettyng why that ye may not be wedded togyther at thys time: Say it nowe, or we do any more to this mater.]

¶ *Si vero aliquis impedimentum aliquod proponere voluerit: et ad hoc probandum cautionem prastiterit: differantur sponsalia quousque rei veritas cognoscatur. Si vero nullus impedimentum proponere voluerit: interroget sacerdos dotem mulieris . . .*

¶ *Postea dicat sacerdos ad virum cunctis audientibus in lingua materna sic.*

N. **V**IS habere hanc mulierem in sponsam, et eam diligere: honorare: tenere: et custodire sanam et infirmam, sicut sponsus debet sponsam: et omnes alias propter eam dimittere, et illi soli adhærere quamdiu vita utriusque vestrum duraverit?

[N. **W**YLT thou have thys woman to thy weddyd wyf

stantially that which was used in the Pre-Reformation Church; but the more homiletic form of it appears to have been imitated from Archbishop Hermann's book.

I require and charge you both] This last and solemn appeal to the consciences of the persons to be married shows how great care has always been taken by the Church to prevent improper marriages. What are impediments to marriage is shown in the proposed rubrics of Bishop Cosin on a preceding page.

if any man do allege and declare any impediment] This is a very difficult rubric; and does not seem ever to have received a judicial interpretation. On the one hand, it appears to stop the marriage only in case the objector submits to "be bound, and sufficient sureties with him, to the parties; or else to put in a caution," &c. On the other, the mere fact of a real impediment alleged by any apparently trustworthy person seems to put it

out of the power of the Clergyman to proceed with the marriage (whether the objector offers security or not) until a legal investigation has taken place. Impediments have been alleged at this part of the service, and the marriage has been stopped in consequence without any other formality; but such a proceeding does not seem to meet the requirement of the rubric, nor to be just to the persons desiring to be married.

§ *The Mutual Consent.*

Although this ceremony may appear to be a mere formality, since it is very improbable that persons will appear before the Clergyman for the purpose of being married unless they have previously come to a decision and agreement on the subject, yet it is a formality respecting which the Church has always been strict; and in the civil contracts which have been adopted under

Deut. xxix. 9.
Numb. xxx. 2.

¶ *The man shall answer,*

I will.

¶ *Then shall the Priest say unto the woman,*

Gen. xxiv. 58.
ii. 18.
Prov. xxxi. 11, 12.
Eph. v. 22, 24, 33.
Tit. ii. 4, 5.
1 Cor. vii. 39.

N. WILT thou have this man to thy wedded husband, to live together after God's ordinance in the holy estate of matrimony? Wilt thou obey him, and serve him, love, honour, and keep him in sickness and in health; and, forsaking all other, keep thee only unto him, so long as ye both shall live?

¶ *The woman shall answer,*

I will.

¶ *Then shall the Minister say,*

Numb. xxx. 3, 4.

1 Cor. vii. 38.
Gen. ii. 22.

Who giveth this woman to be married to this man?

¶ *Then shall they give their troth to each other in this manner.*

¶ *The Minister, receiving the woman at her father's or friend's hands, shall cause the man with his right hand to take the woman by her right hand, and to say after him as followeth,*

Matt. xix. 8.
Mark x. 2, 5-8.
11, 12.

I *N.* take thee *N.* to my wedded wife, to have and to hold from this day forward, for better for worse,

and her loue honour holde and kepe heyl and syke as a housbonde owyth to kepe hys wyf and all other for her to lete and holde the only to her as long as your eyther lyf lastyth?]

¶ *Respondeat vir,*

Volo.

¶ *Item dicat sacerdos ad mulierem hoc modo.*

N. VIS habere hunc virum in sponsum et ei obedire et servire: et eum diligere, honorare, accustodire sanum et infirmum sicut sponsa debet sponsum: et omnes alios propter eum dimittere, et illi soli adherere quamdiu vita utriusque vestrum duraverit?

[**N.** WYLT thou have thys man unto thy housbonde and obeye to hym and serve and hym to love and honour and kepe heil and syke as a wyf owyth to do the housbonde and to lete alle other men for hym and holde the only to hym whylys your eyther lyf lasteth?]

¶ *Respondeat mulier.*

Volo.

[*Deinde Sacerdos.*

Who schal zeve yis woman?]

[MS. Bibl. Reg.
2, B. XXI., A.D.
1408.]

¶ *Deinde detur femina a patre suo, vel ab amicis ejus: quod si puella sit discoopertam habeat manum: si vidua tectam: quam vir recipiat in Dei fide et sua servandam, sicut vocit coram sacerdote, et teneat eam per manum dextram in manu sua dextra, et sic det fidem mulieri per verba de presenti, ita dicens docente sacerdote.*

I *N.* take the *N.* to my wedded wyf to haue and to holde fro this day forwarde for better: for wors: for

modern legislation equal strictness has been observed. In point of fact, forced marriages have not unfrequently taken place, and they are as alien to the spirit in which Holy Matrimony is regarded by the Church as the worst clandestine marriages are. At the last moment, therefore, before the irrevocable step is taken, and the indissoluble bond tied, each of the two persons to be married is required to declare before God and the Church that the marriage takes place with their own free will and consent. This declaration is also worded in such a manner as to constitute a promise in respect to the duties of the married state; and although no solemn adjuration is annexed to this promise, as in the Invocation of the Blessed Trinity afterwards, yet the simple "I will," given under such circumstances, must be taken to have the force of a vow as well as that of an assent and consent to the terms of the marriage covenant as set forth by the Church.

The above English forms of the consent are given from a

Salisbury Ordinale in the British Museum [Harl. MS. 873]. The following are from the York Manual:—

N. Wilt thou haue this woman to thy wyfe: and loue her and kepe her in syknes and in helthe, and in all other degrese be to her as a husbunde sholde be to his wyfe, and all other forsake for her: and holde thee only to her, to thy lynes ende? *Respondeat vir hoc modo:* I wyll.

N. Wylt thou haue this man to thy husbunde, and to be buxum to him, serue him and kepe him in syknes and in helthe: And in all other degrese be vnto hym as a wyfe should be to hir husbunde, and all other to forsake for hym: and holde thee only to hym to thy lynes ende? *Respondeat mulier hoc modo:* I wyll.

§ *The Betrothal.*

That espousal which used, in very ancient times, to take place some weeks or months before the marriage, and which constituted

for richer for poorer, in sickness and in health, to love and to cherish, till death us do part, according to God's holy ordinance; and thereto I plight thee my troth.

¶ *Then shall they loose their hands; and the woman, with her right hand taking the man by his right hand, shall likewise say after the Minister,*

Rom. vii. 2, 3.

I *N.* take thee *N.* to my wedded husband, to have and to hold from this day forward, for better for worse, for richer for poorer, in sickness and in health, to love, cherish, and to obey, till death us do part, according to God's holy ordinance; and thereto I give thee my troth.

richere: for poorer [for fairer for fowler. *Harl. MS.*]: in sykenesse and in hele: tyl dethe vs departe if holy chyrche it woll ordeyne, and therto I plight the my trouthe.

Manum retrahendo.

Deinde dicat mulier docente sacerdote.

I *N.* take the *N.* to my wedded husbander to haue and to holde fro this day forwarde for better: for wors: for richer: for poorer: in sykenesse and in hele: to be bonere and buxum in bedde and at the borde tyll dethe vs departe if holy chyrche it wol ordeyne and therto I plight the my trouthe.

a formal religious recognition of what is now called an "engagement," is represented in our present Office by the previous words of consent, which were called a contract "de futuro." Even when they were thus used, a contract "per verba de presenti" was also made; but the two contracts have long been habitually placed together by the Church as is now the case¹; and the Betrothal more properly consists of this part of the ceremony in which the hands are joined, and each gives their troth or promise of fidelity (which is the marriage vow) to the other.

The present words of betrothal are substantially identical with those which have been used in England from ancient times. Three variations are here printed; which, with that given above, will fully illustrate the language in which they were spoken from about the thirteenth to the sixteenth century.

Salisbury Use.

York Use.

Hereford Use.

I *N.* take the *N.* to my weddyd wyf to haue and to holde fro thys day wafor beter, for worse, for rycher, for porer: in sykenesse and in helthe, tyl deth us departe² yf holy chyrch wol it ordeyne and ther to I plycht the my trouthe³.

Here I tak the *N.* to my wedded wyff to holde and to haue att bed and att borde for fairer for laither⁴, for better for wars, in, sickness and in heile till dethe us depart and thereto plyght I the my trouthe.

I, *N.*, underfyng the, *N.*, for my wedded wyf, for betere for worse, for richer for porer, yn sekene and in helthe tyl deth us departe, as holy church hath ordeyned, and therto y plyth the my trouthe.

I *N.* take the *N.* to my weddyd husbande to haue and to holde fro⁵ thys day for bether, for wars, for richer, for porer, in sykenesse and in helthe to be bonour and buxum⁶ in bed and at bort: tyl deth us departe yf holy chyrche wol it ordeyne: and ther to I plyche te my trouthe.

Here I tak the *N.* to my wedded husband to hold and to haue att bed and att borde for fairer for laither, for better for wars, in sikeness and in heile till dethe to I plyght the my trouthe.

I, *N.*, underfyng the *N.*, for my wedded husband, for better, for worse, for richer, for porer, yn sekene and in helthe, to be buxum to the tyl deth us departe, as holy church hath ordeyned, and tharto y plit the my trouthe.

The words, and the accompanying ceremony, which are thus handed down to us from the ancient Church of England, have a very striking Christian significance. In the ceremony of betrothal it will be observed that woman is recognized throughout as still subject to the law of dependence under which she was originally placed by the Creator. As soon as the mutual consent of both the man and the woman has been solemnly given in the face of God and the Church, the minister of the Office is directed to ask, "Who giveth this woman to be married to this man?" Then she is given up from one state of dependence to another, through the intermediate agency of the Church; "the minister receiving the woman at her father's or friend's hands" (to signify that her father's authority over her is returned into the hands of God, Who gave it), and delivering her into the hands of the man in token that he receives her from God, Who alone can give a husband authority over his wife. The quaint but venerable and touching words with which the two "give their troth to each other" express again and in a still more comprehensive form the obligations of the married state which were previously declared in the words of mutual consent. Each promises an undivided allegiance to the other, until the death of one or the other shall part them asunder; God joining them together, and His Providential dispensation alone having power to separate

am him the lathere." [Lazamon's Brut, i. 37.] The word "fouler" is used in some Salisbury Manuals: and each, of course, expresses the idea of "less fair," or "less pleasing."

² This is a conjectural emendation. The word is "for" in two copies.
³ "Bonour and buxum" are the representatives of "Bonnaire," gentle (as in *débonair*), and "Boughsome," obedient. Some Manuals added "in all lawful places." In the Golden Litany printed by Maskell [Mon. Rit. ii. 245] one of the petitions is, "By Thy infinite buxomnes: have mercy on us." In the Promptorium Parvulorum the two equivalents *Humilitas* and *Obedientia* are given under the word Buxumnesse.

¹ Yet there is evidence of separate espousals having been made as late as the time of Charles I. For in the Parish Register of Boughton Monchelsea, in Kent, is the following entry:—"Michaelis. 1630. Sponsalia inter Gulielm. Maddox et Elizabeth Grimestone in debit' juris formā transacta, 10 die Januarii." Two years and three-quarters afterwards comes the entry of the marriage:—"Michaelis. 1633. Nuptia inter Gulielmū Maddox et Elizabethā Grimestone, ultimo Octobris." [Burns' Hist. of Fleet Marriages, p. 2.] The ancient oath of espousals was administered in this form: "You swear by God and His holy saints herein, and by all the saints in Paradise, that you will take this woman, whose name is *N.*, to wife, within forty days, if Holy Church will permit." The hands of the man and woman being then joined together by the priest, he also said, "And thus ye affianc yourselves," to which they made an affirmative reply, an exhortation concluding the ceremony.

² "Depart" is sound English for "part asunder," which was altered to "do part" in 1661, at the pressing request of the Puritans, who knew as little of the history of their national language as they did of that of their national Church.

³ "Troth," or "Trowth," is commonly identified with "truth;" but this is an error, the meaning of the word being "fidelity," or "allegiance." To "give troth" is equivalent to "fidem dare."

⁴ "Laither:" this is the old comparative degree of "loath," as in "Ihe

¶ Then shall they again loose their hands, and the man shall give unto the woman a ring, laying the same upon the book, with the accustomed duty to the Priest and Clerk. And the Priest taking the ring, shall deliver it unto the man, to put it upon the fourth finger of the woman's left hand. And the man holding the ring there, and taught by the Priest, shall say,

Ruth iv. 7-9.
11-13.
Gen. xxiv. 50, 51.
53. 67. xxxi. 50.
Col. iii. 17.

WITH this ring I thee wed, with my body I thee worship, and with all my worldly goods I thee endow: In the Name of the Father, and of the Son, and of the Holy Ghost. Amen.

Manum retrahendo.

Deinde ponat vir aurum : argentum : et anulum super scutum vel librum : . . . tunc . . . accipiens sacerdos anulum tradat ipsum viro : quem vir accipiat manu sua dextera cum tribus principalioribus digitis, et manu sua sinistra tenens dexteram sponsæ docente sacerdote dicat,

WITH this rynge I the wed, and this gold and siluer I the geue, and with my body I the worshipec, and with all my worldely cathel I the endowe. *Et tunc inserat sponsus anulum pollicis sponsæ dicens. In nomine Patris : deinde secundo digito dicens. et Filii : deinde tertio digito dicens : et Spiritus Sancti. deinde quarto digito dicens. Amen. ibique dimittat anulum . . . Deinde inclinatis eorum capitibus dicat sacerdos benedictionem super eos. . . .*

them. On both sides a promise is given of love and support under all the circumstances of life, prosperous or adverse. The duties of support, shelter, and comfort, which ordinarily devolve upon the husband chiefly may, under some circumstances (though they rarely arise), fall chiefly upon the wife; and if by sickness and infirmity he is unable to fulfil them towards her, he has a claim upon her, by these words, that she shall perform them towards him. Under any circumstances each promises to be a stay to the other, according to their respective positions and capacities, on their way through life. In the marriage vow of the woman the modern phrase "to obey" is substituted for the obsolete one "to be buxom," which had the same meaning. It implies that although the woman's dependence on and obedience to her father has been given up by him into God's hands, it is only that it may be given over to her husband. Since it pleased our Blessed Lord to make woman the instrument of His Incarnation, her condition has been far more honourable than it was before; but part of that honour is that "the husband is the head of the wife, even as Christ is the Head of the Church." Natural instinct, good sense, mutual love, and, above all, religious feeling, will always enable the wife to discern how far she is bound to obey, and the husband how far it is his duty to rule; and regulated by these the yoke of obedience will never be one which the woman need regret to wear or wish to cast aside. Jeremy Taylor has well pointed out that nothing is said in the husband's part of the marriage vow about "rule," for this is included in the word "love." "The dominion of a man over his wife is no other than as the soul rules the body; for which it takes a mighty care, and uses it with a delicate tenderness, and cares for it in all contingencies, and watches to keep it from all evils, and studies to make for it fair provisions, and very often is led by its inclinations and desires, and does never contradict its appetites but when they are evil, and then also not without some trouble and sorrow; and its government comes only to this—it furnishes the body with light and understanding; and the body furnishes the soul with hands and feet; the soul governs because the body cannot else be happy." So also he writes in respect to the obedience of the wife: "When God commands us to love Him, He means we should obey Him: 'this is love, that ye keep My commandments;' and 'if ye love Me, keep My commandments.' Now, as Christ is to the Church, so is the man to the wife, and therefore obedience is the best instance of her love, for it proclaims her submission, her humility, her opinion of his wisdom, his pre-eminence in the

family, the right of his privilege, and the injunction imposed by God upon her sex, that although 'in sorrow she bring forth children,' yet with 'love and choice she should obey.' The man's authority is love, and the woman's love is obedience¹."

§ The Marriage.

With this ring I thee wed] The use of the wedding ring was probably adopted by the early Church from the marriage customs which were familiar to Christians in their previous life as Jews and Heathens²: for the ring, or something equivalent to it, appears to have been given by the man to the woman at the marriage or at espousals, even from those distant patriarchal days when Abraham's steward betrothed Rebekah on behalf of Isaac, by putting "the earrings upon her face and the bracelets upon her hands." Much pleasing symbolism has been connected with the wedding ring, especially that its form having neither beginning nor end, it is an emblem of eternity, constancy, and integrity. This meaning is brought out in the ancient form of consecrating a Bishop, when the ring was delivered to him with the words, "Receive the ring, the seal of faith, to the end that being adorned with inviolable constancy, thou mayest keep undefiled the spouse of God, which is His holy Church." The same form of blessing the ring was used in this case, as was used in the Marriage Service, and which is printed above. Probably it has always been taken as a symbol of mutual truth and intimate union, linking together the married couple, in the words of the ancient exhortation, "That they be from this tyme forth, but one body and two souls in the fayth and lawe of God and holy Chyrche." It is the only relic of the ancient tokens of spousage,—gold, silver, and a ring being formerly given at this part of the service: and as the gold and silver were given as symbols of dowry, so probably one idea, at least, connected with the ring, was that of the relation of dependence which the woman was henceforth to be in towards her husband. In the Prayer Book of 1549 the gold or silver were still directed to be given, (and in Bishop Cosin's revised Prayer Book, he proposed a restoration of the custom, inserting, "and other tokens of spousage as gold, silver, or bracelets," after the word 'ring,') but in 1552 "the accustomed duty to the Priest and Clerk" was substituted, and ultimately retained in the revision of 1661. It is possible

¹ Bishop Taylor's Sermon on the Marriage Ring.

² Tertullian speaks of the Roman matron's "one finger, on which her husband had placed the pledge of the nuptial ring." Tertull. Apol. vi., De Idol. xvi.

¶ Then the man leaving the ring upon the fourth finger of the woman's left hand, they shall both kneel down and the Minister shall say,

Let us pray.

Phil. iv. 6.
Hev. iv. 11.
Job vii. 20.
1 Pet. v. 10.
Gen. i. 28.
2 Sam. vii. 29.
Gen. xxiv. 67.
Eccl. v. 4.
Deut. xxiii. 21, 23.
Col. iii. 18, 19.
Luke i. 5, 6.
Ps. cxix. 165.

O ETERNAL God, Creator and Preserver of all mankind, Giver of all spiritual grace, the Author of everlasting life; Send thy blessing upon these thy servants, this man and this woman, whom we bless in thy Name; that, as Isaac and Rebecca lived faithfully together, so these persons may surely perform and keep the vow and covenant betwixt them made, (whereof this ring given and received is a token and pledge,) and may ever remain in perfect love and peace together, and live according to thy laws; through Jesus Christ our Lord. *Amen.*

[CREATOR et conservator humani generis: dator gratiæ spiritualis: largitor æternæ salutis: tu, Domine, mitte benedictionem tuam super hunc annulum, respice, ut quæ illum gestaverit sit armata virtute cœlestis defensionis, et proficiat illi ad æternam salutem. Per Christum.

Benedic, Domine, hunc annulum, respice, quem nos in tuo sancto nomine benedicimus: ut quæcumque eum portaverit in tua pace consistat: et in tua voluntate permaneat: et in tuo amore vivat et crescat et senescat: et multiplicetur in longitudinem dierum. Per Dominum.]

that the "gold or silver" had customarily been appropriated as the marriage fee: but Hooker says that the use of them had "in a manner already worn out" even so early as the time of

Queen Elizabeth. The following forms of the words with which the ring was given, and Cosin's proposed form, will further illustrate the subject:—

York Use.

With this synge I wedde the, and with this gold and silver I honoure the, and with this gyft I honoure the. In nomine Patris: et Filii: et Spiritus Sancti. Amen.

Hereford Use.

Wyth thys ryng y the wedde, and thys gold and seluer ych the zeue, and wyth myne body ych the honoure. In nomine Patris: et Filii: et Spiritus Sancti. Amen.

Prayer Book of 1549.

With this ring I thee wed, this gold and silver I thee give, with my body I thee worship, and with all my worldly goods I thee endow: in the Name of the Father, and of the Son, and of the Holy Ghost. Amen.

Form proposed by Bishop Cosin, 1661.

With this ring I thee wed, and receive thee into the holy and honourable estate of matrimony: In the Name of the Father, and of the Son, and of the Holy Ghost. Amen.

An old manual in the British Museum [Bibl. Reg. 2. A. xxi.] has also the following words in addition, explaining the object of the gold and silver:—

"Loo this gold and this siluer is leyd down in signifyinge that the woman schal haue hure dower of thi goodes, þif heo abide aftur thy disces."

The ring was anciently placed first on the thumb at the invocation of the First Person of the Trinity, on the next finger at the Name of the Second, on the third at the Name of the Third, and on the fourth at the word Amen. The expression of the second rubric, "*leaving the ring upon the fourth finger*," seems to point to this custom as still observed, and still intended. The ancient rubric also gave as a reason for its remaining on the fourth finger, "*quia in medico est quedam vena procedens usque ad cor*;" and this reason has become deeply rooted in the popular mind. The same rubric also adds "*et in sonoritate argenti designatur interna dilectio, quæ semper inter eos debet esse recens*."

[with my body I thee worship] The meaning of the word "worship" in this place is defined by the word used in its place in some of the ancient Manuals, which (as may be seen above) was "honour." The Puritans always objected to the word; and in 1661 it was agreed that "honour" should be substituted, the alteration being made by Sancroft in Bishop Cosin's revised Prayer Book instead of the change suggested by Cosin himself. But either by accident, or through a change of mind on the part of the Revision Committee, the old word was allowed to remain. The more exclusive use of this word in connexion with Divine Service is of comparatively modern date. In the Liber Festivalis,

printed by Caxton in 1483, an Easter homily calls every gentleman's house a "place of worship," and in the same century a prayer begins "God that commandest to worship fadir and modir." This secular use of it is still continued in the title "your worship," by which magistrates are addressed, and in the appellation "worshipful companies." The expression "with my body I thee worship" or "honour" is equivalent to a bestowal of the man's own self upon the woman, in the same manner in which she is delivered to him by the Church from the hands of her father. Thus he gives first the usufruct of his person in these words, and in those which follow, the usufruct of his possessions or worldly goods.

As far as the ceremony of marriage is a contract between the man and the woman, it is completed by the giving of the ring with this solemn invocation of the Blessed Trinity. In all that follows they are receiving the Benediction of the Church, and its ratification of their contract.

[they shall both kneel down] All present should also kneel at this prayer, except the Priest. It is the only part of the Service, in the body of the Church, at which the bystanders are required to kneel; but the married couple ought to continue kneeling until the commencement of the Psalm or Introit. The prayer which follows is founded upon the ancient benediction of the ring. It takes the place of a long form of blessing which followed the subarrhation in the ancient Office. In 1549 the parenthesis "(after bracelets and jewels of gold given of the one to the other for tokens of their matrimony)" followed the names of Isaac and Rebecca; which indicates the origin of Cosin's proposed dowry of bracelets.

¶ *Then shall the Priest join their right hands together, and say,*

Matt. xix. 5, 6. Those whom God hath joined together, let no man put asunder.

¶ *Then shall the Minister speak unto the people.*

Mal. ii. 14—16.

FORASMUCH as *N.* and *N.* have consented together in holy wedlock, and have witnessed the same before God and this company, and thereto have given and pledged their troth either to other, and have declared the same by giving and receiving of a ring, and by joining of hands; I pronounce that they be man and wife together, In the Name of the Father, and of the Son, and of the Holy Ghost. Amen.

*Gen. xxiv. 58, 67.
Ruth iv. 9, 10.*

*Matt. xviii. 18.
Col. iii. 17.*

¶ *And the Minister shall add this Blessing,*

*2 Cor. xiii. 14.
Numb. vi. 24—26.
Ps. cxxxiv. 3.
cxix. 58, 132.
Eph. i. 3. iii. 14.
16—19.
1 Pet. iii. 7.
Rom. vi. 22.*

GOD the Father, God the Son, God the Holy Ghost, bless, preserve, and keep you; the Lord mercifully with his favour look upon you; and so fill you with all spiritual benediction and grace, that ye may so live together in this life, that in the world to come ye may have life everlasting. Amen.

¶ *Then the Minister or Clerks, going to the Lord's table, shall say or sing this Psalm following.*

Beati omnes. Psalm cxxviii.

¶ *Or this Psalm.*

Deus misereatur. Psalm lxvii.

[Printed at length
in the Sealed
Books.]

¶ *And so lette the minister ioine their right handes together, and saye,*

That, that God hath ioyned, lette no man dissever.

¶ *And lette the pastour say more over, with a lowde voice, that maye be hearde of all men,*

FORASMUCHE as than thys Johan *N.* desireth thys Anne to be hys wife in the Lorde, and this Anne desireth thys Johan to be hir husbunde in the Lorde, and one hath made the other a promisse of holie and Christian matrimonie, and haue now both professed the same openly, and haue confirmed it with giuinge of ringes ech to other, and ioininge of handes: I the minister of Christ and the congregation pronounce that they be ioyned together with lawfull and Christian matrimony, and I confirme this their mariage in the Name of the Father, the Sonne, and the Holie Gost. Amen.

Daye's transl. of
Herman's Con-
sult., A.D. 1547.

BENEDICAT vos Deus Pater, custodiat vos Iesus Christus, illuminet vos Spiritus Sanctus. Ostendat Dominus faciem suam in vobis et misereatur vestri. Convertat Dominus vultum suum ad vos: et det vobis pacem: impleatque vos omni benedictione spirituali, in remissionem omnium peccatorum vestrorum ut habeatis vitam æternam, et vivatis in sæcula sæculorum. Amen.

Saisbury Use.

¶ *Hic intrent ecclesiam usque ad gradum altaris: et sacerdos in eundo cum suis ministris dicat hunc psalmum sequentem.*

Beati omnes.

Those whom God hath joined together] This sentence of marriage with its accompanying gesture of joining the bride and bridegroom's hands is a noble peculiarity of the English rite, though probably derived originally from Archbishop Hermann's Consultation. It completes the Marriage rite so far as to make it spiritually indissoluble, and may be considered as possessing a sacramental character in that lower sense in which those rites have it, the outward signs of which were not ordained by Christ Himself. There are hardly any words in the Prayer Book which more solemnly declare the faithful conviction of the Church that God ratifies the work of His Priests. In this case and in the Ordination Service the very words of our Lord Himself are adopted as the substantial and effective part of the rite: and each case is an assertion of the very highest spiritual claims that can be made on behalf of an earthly ministry. As there the Bishop says unconditionally, "Receive the Holy Ghost;" so here the Priest says unconditionally, that "God hath joined together"

these two persons by his ministry. The words were part of the ancient Gospel at the Missa sponsalium.

Forasmuch as N. and N. have consented] This declaration of the completed union is also taken from Archbishop Hermann's Cologne book. It bears an analogy to the words used at the consignment of the child after Baptism; and, as in that case, it is a proclamation to the Church of what has already been effected by previous parts of the rite.

And the Minister shall add this Blessing] In the Prayer Book of 1549 this blessing stood as follows:—"God the Father bless you + God the Son keep you: God the Holy Ghost lighten your understanding: the Lord mercifully with His favour look upon you, and so fill you with all benediction and grace, that you may have remission of your sins in this life, and in the world to come, life everlasting." It was changed to the present form in 1552.

Then the Minister or Clerks, going to the Lord's table] This

¶ *The Psalm ended, and the man and the woman kneeling before the Lord's table, the Priest standing at the table, and turning his face towards them, shall say,*

Lord, have mercy upon us.

Answer.

Christ, have mercy upon us.

Minister.

Lord, have mercy upon us.

OUR Father, which art in heaven, Hallowed be thy Name. Thy kingdom come. Thy will be done in earth, As it is in heaven. Give us this day our daily bread. And forgive us our trespasses, As we forgive them that trespass against us. And lead us not into temptation; But deliver us from evil. Amen.

Minister.

Ps. lxxxvi. 2. O Lord, save thy servant, and thy handmaid;

Answer.

Who put their trust in thee.

Minister.

Ps. xx. 1, 2. O Lord, send them help from thy holy place;

Answer.

And evermore defend them.

Minister.

Ps. lxi. 3. Be unto them a tower of strength,

Answer.

From the face of their enemy.

Minister.

Ps. cii. 1. O Lord, hear our prayer.

Answer.

And let our cry come unto thee.

¶ *Tunc prostratis sponso et sponsa ante gradum altaris, roget sacerdos circumstantes orare pro eis, dicendo,*

Kyrie Eleison.

Christe Eleison.

Kyrie Eleison.

PATER noster, qui es in caelis; sanctificetur nomen tuum: adveniat regnum tuum: fiat voluntas tua, sicut in caelo, et in terra. Panem nostrum quotidianum da nobis hodie: et dimitte nobis debita nostra, sicut et nos dimittimus debitoribus nostris: et ne nos inducas in tentationem: sed libera nos a malo. Amen.

Salvum fac servum tuum et ancillam tuam.

Deus meus, sperantes in te.

Mitte eis, Domine, auxilium de sancto.

Et de Syon tuere eos.

Esto eis, Domine, turris fortitudinis.

A facie inimici.

Domine, exaudi orationem meam.

Et clamor meus ad te veniat.

Dominus vobiscum.

Et cum spiritu tuo.

originally stood "Then shall they go into the quire," and Cosin wished so to restore it, with the alteration "they all." The proper interpretation of the rubric doubtless is that the Clergy, the Choir, the bride and bridegroom, and the bridal party are to go from the body of the church in procession to the chancel, singing the processional psalm *Beati omnes*: that the Clergy proceed to the Altar as at ordinary celebrations of the Holy Communion, the bride and bridegroom kneeling in front of the Altar, with the bridal party behind them, while the choir go to their usual places. To effect this without confusion, the choir should move first in their proper order, the clergy next, after them the bride and bridegroom, and then the remainder of the bridal party. Thus the singers can at once file off to their places in the choir, while the clergy pass on to the sacarium, and the bridal party to the presbytery or space between the altar steps and choir stalls. Such arrangements can only be carried out well in large churches, but they give the key to the manner in which the spirit of the rubric may be acted upon, as far as

circumstances will allow, elsewhere: and as a procession is an invariable part of every wedding, where there is a bridal party of friends, it is very desirable that it should be properly worked into the system of the Church, instead of being left to the chance of the moment, and the confused attempts of nervous people.

The portion of the service which follows the psalm, onward to the end of the benediction, is to be regarded as preparatory to the Holy Communion. In the old offices it was followed by the Sunday Missa Votiva, that of the Blessed Trinity, the Epistle being however 1 Cor. vi. 15—20, and the Gospel, Matt. xix. 3—6.

the Priest standing at the table] There is no pretence whatever for the priest to place himself awkwardly in the angle formed by the north end of the Lord's table and the east wall. He is clearly to stand in front of the table. The office having the nature of a benediction is therefore said towards the persons blessed. There was, indeed, in the ancient Office, and in that of 1549, a "Let us pray" after the versicles, from which it might be reasonably concluded that the Priest was then to turn towards

Minister.

Matt. xxii. 31, 32.
Gen. xxviii. 3, 4.
Luke viii. 11, 15.
2 Tim. iii. 16, 17.
James i. 22. ii. 8.
Deut. xxvi. 15.
Gen. xvii. 16.
xxviii. 3, 4.
Ps. cxli. 1-3.
xxiv. 3-5.
John xv. 4.
1 John ii. 17.

O GOD of Abraham, God of Isaac, God of Jacob, bless these thy servants, and sow the seed of eternal life in their hearts; that whatsoever in thy holy Word they shall profitably learn, they may in deed fulfil the same. Look, O Lord, mercifully upon them from heaven, and bless them. And as thou didst send thy blessing upon Abraham and Sarah, to their great comfort, so vouchsafe to send thy blessing upon these thy servants; that they obeying thy will, and always being in safety under thy protection, may abide in thy love unto their lives' end; through Jesus Christ our Lord. *Amen.*

¶ *This Prayer next following shall be omitted, where the woman is past childbearing.*

Gen. i. 28.
xxxiii. 3.
Ps. cxviii. 3.
cxliv. 12, 15.
Prov. xxxi. 10, 11.
38.
Eph. vi. 4.
Gen. xviii. 19.

O MERCIFUL Lord, and heavenly Father, by whose gracious gift mankind is increased; We beseech thee, assist with thy blessing these two persons, that they may both be fruitful in procreation of children, and also live together so long in godly love and honesty, that they may see their children christianly and virtuously brought up, to thy praise and honour; through Jesus Christ our Lord. *Amen.*

Heb. xi. 3.
Gen. ii. 4. i. 27.
ii. 21-24.
Matt. xix. 4-6.
1 Cor. vii. 10.
Isa. lxii. 5.
Rev. xxi. 2. xix.
7, 8.
Eph. v. 23-32.
1 Pet. iii. 7.
2 Cor. xiii. 11.
Tit. ii. 4, 5.
Ps. cxviii. 1, 2.

O GOD, who by thy mighty power hast made all things of nothing; who also (after other things set in order) didst appoint that out of man (created after thine own image and similitude) woman should take her beginning; and knitting them together, didst teach that it should never be lawful to put asunder those whom thou by matrimony hadst made one: O God, who hast consecrated the state of matrimony to such an excellent mys-

Oremus.

DEUS Abraham, Deus Isaac, Deus Jacob, benedice adolescentes istos: et semina semen vitæ æternæ in mentibus eorum: ut quicquid pro utilitate sua didicerint, hoc facere cupiant. Per.

Oremus.

Respice, Domine, de cælis, et benedice conventionem istam. Et sicut misisti sanctum angelum tuum Raphaellem ad Tobiam et Saram filiam Raguelis: ita digneris, Domine, mittere benedictionem tuam super istos adolescentes: ut in tua voluntate permanent: et in tua securitate persistent: et in amore tuo vivant et senescant: ut digni atque pacifici fiant et multiplicentur in longitudinem dierum. Per Christum Dominum nostrum.

Oremus.

RESPICE, Domine, propitius super hunc famulum tuum, respice. et super hanc famulam tuam: respice. ut in nomine tuo benedictionem cælestem accipiant: et filios filiorum suorum et filiarum suarum usque in tertiam et quartam progeniem incolumes videant, et in tua voluntate perseverent, et in futuro ad cælestia regna perveniant. Per Christum.

Oremus.

DEUS, qui potestate virtutis tuæ, *Ad Missam* de nihilo cuncta fecisti: qui dispositis universitatis exordiis, homini ad imaginem Dei facto ideo inseparabile mulieris adjutorium condidisti, ut fœmineo corpori de virili dares carne principium, docens quod ex uno placuisset institui, nunquam liceret disjungi. *Hic incipit benedictio sacramentalis:* Deus, qui tam excellenti mysterio conjugalem copulam consecrasti, ut Christi et ecclesiæ sacramen-

the Altar, in the direction in which all prayers were intended to be said: but the nature of the rite is essentially benedictory; and as even the final blessing is preceded by "Oremus" in the Latin form, the former conclusion seems to be the correct one.

The concluding prayers have undergone little change in the course of translation from the ancient Latin Office; and only a portion of the last of all can be traced back to the ancient Sacramentaries.

christianly and virtuously brought up] This expression was

substituted for "see their children's children unto the third and fourth generation," at the last revision in 1661.

who hast consecrated the state of matrimony] Among the exceptions offered against the Prayer Book by Baxter and his friends in 1661 was the following: "Seeing the institution of Marriage was before the Fall, and so before the promise of Christ, as also for that the said passage in this collect seems to countenance the opinion of making matrimony a sacrament, we desire that clause may be altered or omitted." To this the Committee of

tery, that in it is signified and represented the spiritual marriage and unity betwixt Christ and his Church; Look mercifully upon these thy servants, that both this man may love his wife, according to thy Word, (as Christ did love his spouse the Church, who gave himself for it, loving and cherishing it even as his own flesh,) and also that this woman may be loving and amiable, faithful and obedient to her husband; and in all quietness, sobriety, and peace, be a follower of holy and godly matrons. O Lord, bless them both, and grant them to inherit thy everlasting kingdom; through Jesus Christ our Lord. *Amen.*

¶ *Then shall the Priest say,*

Gen. ii. 7. 18. 21—
28 iii. 20.

ALMIGHTY God, who at the beginning did create our first parents, Adam and Eve, and did sanctify and join them together in marriage; Pour upon you the riches of his grace, sanctify and bless you, that ye may please him both in body and soul, and live together in holy love unto your lives' end. *Amen.*

Eph. ii. 7.
John xv. 9, 10, 12.
1 Thess. v. 23, 24.
Ps. cxv. 13, 14.

¶ *After which, if there be no Sermon declaring the duties of man and wife, the Minister shall read as followeth,*

ALL ye that are married, or that intend to take the holy estate of matrimony upon you, hear what the holy Scripture doth say as touching the duty of husbands towards their wives, and wives towards their husbands.

Eph. v. 25—33.

Saint Paul, in his Epistle to the Ephesians, the fifth Chapter, doth give this commandment to all married men;

tum præsignares in fœdere nuptiarum. *Hic finitur benedictio sacramentalis.*

. . . respice, propitius super hanc famulam tuam quæ maritali jungenda est consortio, quæ se tua expetit protectione muniri. Sit in ea jugum dilectionis et pacis: fidelis et casta nubat in Christo: imitatrixque sanctarum permaneat feminarum. Sit amabilis ut Rachel viro: sapiens ut Rebecca: longæva et fidelis ut Sara . . . et ad beatorum requiem atque ad cœlestia regna perveniat. Per Dominum . . . Per omnia sæcula sæculorum. Amen.

Deinde benedicat eos dicens. Oremus. Oratio.

OMNIPOTENS misericors Deus, qui primos parentes nostros Adam et Evam sua virtute creavit, et sua sanctificatione copulavit: . . . superabundet in vobis divitias gratiæ suæ, et erudiat vos in verbo veritatis, ut ei corpore pariter et mente complacere valeatis . . . atque in societate et amore veræ dilectionis conjungat. Per Christum, Dominum nostrum. Amen.

Husbands, love your wives, even as Christ also loved the Church, and gave himself for it, that he might sanctify and cleanse it with the washing of water, by the Word; that he might present it to himself a glorious Church, not having spot, or wrinkle, or any such thing; but that it should be holy, and without blemish. So ought men to love their wives as their own bodies. He that loveth his wife loveth himself: for no man ever yet hated his own flesh, but nourisheth and cherisheth it,

Convocation replied: "Though the institution of marriage was before the Fall, yet it may be now, and is, consecrated by God to such an excellent mystery as the representation of the spiritual marriage between Christ and His Church [Eph. v. 23]. We are sorry that the words of Scripture will not please. The Church, in the twenty-fifth article, hath taken away the fear of making it a sacrament" [Cardw. Conf. 330. 360.] The singular answer of the Puritan opponents of the Prayer Book to this was, "When was Marriage thus consecrated? If all things, used to set forth Christ's offices, or benefits, by way of similitude, be consecrated, then a Judge, a Father, a Friend, a Vine, a Door, a Way, &c., are all consecrated things. Scripture phrase pleaseth us in Scripture sense." [Grand Debate, p. 140.]

loving and amiable] After these words there followed, until

1661, "to her husband, as Rachael, wise as Rebecca, faithful and obedient as Sara," as in the ancient form.

Pour upon you the riches] In this benediction the sign of the Cross was printed in the Prayer Book of 1549, thus: "sanctify and + bless you." It was omitted in 1552, being no doubt left out to conciliate the Puritan superstition on the subject, and intended, as in other places, to be part of a rubrical tradition which those would use who respected and loved that holy sign. The benediction is made up from two consecutive Sarum forms.

After which, if there be no Sermon] Until 1661 this rubric stood in this form—"¶ *Then shall begin the Communion, and after the Gospel shall be said a Sermon, wherein ordinarily (so oft as there is any marriage) the office of a man and wife shall be declared, according to Holy Scripture. Or if there be no*

even as the Lord the Church: for we are members of his body, of his flesh, and of his bones. For this cause shall a man leave his father and mother, and shall be joined unto his wife; and they two shall be one flesh. This is a great mystery; but I speak concerning Christ and the Church. Nevertheless, let every one of you in particular so love his wife, even as himself.

Col. iii. 19. Likewise the same Saint Paul, writing to the Colossians, speaketh thus to all men that are married; Husbands, love your wives, and be not bitter against them.

1 Pet. iii. 7. Hear also what Saint Peter, the Apostle of Christ, who was himself a married man, saith unto them that are married; Ye husbands, dwell with your wives according to knowledge; giving honour unto the wife, as unto the weaker vessel, and as being heirs together of the grace of life, that your prayers be not hindered.

Hitherto ye have heard the duty of the husband toward the wife. Now likewise, ye wives, hear and learn your duties toward your husbands, even as it is plainly set forth in holy Scripture.

Eph. v. 22-24. Saint Paul, in the aforementioned Epistle to the Ephesians, teacheth you thus; Wives, submit yourselves unto your own husbands, as unto the Lord. For the husband is the head of the wife, even as Christ is the head of the Church: and he is the Saviour of the body. Therefore as the Church is sub-

ject unto Christ, so let the wives be to their own husbands in every thing. And again he saith, Let the wife see that she reverence her husband.

And in his Epistle to the Colossians, *Col. iii. 18.* Saint Paul giveth you this short lesson; Wives, submit yourselves unto your own husbands, as it is fit in the Lord.

Saint Peter also doth instruct you *1 Pet. iii. 1. 3-6.* very well, thus saying; Ye wives, be in subjection to your own husbands; that, if any obey not the word, they also may without the word be won by the conversation of the wives; while they behold your chaste conversation coupled with fear. Whose adorning, let it not be that outward adorning of plaiting the hair, and of wearing of gold, or of putting on of apparel; but let it be the hidden man of the heart, in that which is not corruptible; even the ornament of a meek and quiet spirit, which is in the sight of God of great price. For after this manner in the old time the holy women also, who trusted in God, adorned themselves, being in subjection unto their own husbands; even as Sarah obeyed Abraham, calling him lord; whose daughters ye are as long as ye do well, and are not afraid with any amazement.

¶ *It is convenient that the new married persons should receive the holy Communion at the time of their Marriage, or at the first opportunity after their Marriage.*

Sermon, the Minister shall read this that followeth." Bishop Cosin altered this to, "Then shall begin the Communion if any be that day appointed. And after the Gospel and Creed shall be said a Sermon wherein it is expedient that the office of man and wife be declared according to Holy Scripture. Or if there be no Sermon, the Minister shall read this that followeth." Bishop Jeremy Taylor and Dr. Donne have left some beautiful sermons preached on occasion of marriages: and the custom seems to have been not uncommon.

It is convenient . . . the holy Communion] The practice of connecting the Marriage Office with the Holy Communion fell into strange disuse during the last and present centuries. In the old manuals the mass of the Holy Trinity concluded the Office, and there is no reason to suppose that it was ever omitted. Until 1661 the rubric stood—"¶ *The new married persons (the same day of their marriage) must receive the holy Communion.*" This is altered in Bishop Cosin's revised Prayer Book to "*The new married persons, the same day of their marriage, must receive the Holy Communion; unto which the minister is now to proceed, reading the Offertory &c. according to the form prescribed.*" The present form of the rubric was adopted in deference to the objection of the Puritans, who wished to dis-

sociate the Office from the Holy Communion, from the morbid fear which they had of attaching too much importance to the religious rite with which Marriage is celebrated by the Church. But "*convenient*" is used in its strict and primary sense of "fit" or "proper," the secondary sense being a more modern one. From Bishop Cosin's proposed rubric it would appear as if the Holy Communion was used on such occasions without the introductory lection of the ten commandments. "To end the public solemnity of marriage," says Hooker, "with receiving the blessed Sacrament, is a custom so religious and so holy, that if the Church of England be blameable in this respect, it is not for suffering it to be so much, but rather for not providing that it may be more put in use." [Ecc. Polit. V. lxxiii. 8.]

A custom which retains its hold in some churches, that of kissing the bride, is derived from the Salisbury rubric concerning the Pax in the Missa Sponsalium, which is:—"Tunc amoto pallio, surgant ambo sponsus et sponsa: et accipiat sponsus pacem a sacerdote, et ferat sponsæ osculans eam et neminem alium, nec ipse nec ipsa: sed statim diaconus vel clericus a presbytero pacem accipiens, ferat aliis sicut solitum est." This took place immediately before the Communion of the newly-married couple.

AN INTRODUCTION

TO THE

OFFICE FOR THE VISITATION OF THE SICK.

THE duty of visiting the sick is specially enjoined on the Curates of souls in the New Testament: "Is any sick among you? let him call for the elders of the church; and let them pray over him, anointing him with oil in the name of the Lord; and the prayer of faith shall save the sick, and the Lord shall raise him up; and if he have committed sins, they shall be forgiven him" [James v. 14, 15]. The Visitation of the Sick is not therefore in the minister of Christ a mere piece of civility or neighbourly kindness, but an act of religion. He comes in the name of Christ to pray with and for the sick man; if necessary, to reconcile him to the Church by the blessing of absolution, and to communicate to him the Sacrament of our Lord's body and blood. That the primitive clergy of the Church made this visitation in time of sickness their special duty, is proved to us by many passages in early writers. Polycarp, the disciple of St. John, in his Epistle to the Philippians, gives it as advice to presbyters, ἐπισκέπτεσθαι τοὺς ἀσθενεῖς. Posidonius, in his Life of St. Augustine [cap. 27], relates that the Saint, as soon as he knew any man was sick, went unto him immediately. The decrees of various early Councils enjoined this duty on the Clergy whenever they were called for; and the Council of Milan goes even further than this, and orders, "Etiam si non vocati inuisant." Our own Provincial Constitutions require all Rectors and Vicars of Parishes to be diligent in their visitations to those who are sick, and warn them, "Ut quoties fuerint accersiti, celeriter accedant et hilariter ad aegrotos." [Lyndwood, Prov. Const. i. 2.] In our Post-Reformation system we find also that ample provision is made for the continuance of this ancient and laudable custom. Canon 67, "Ministers to visit the Sick," directs, "When any person is dangerously sick in any Parish, the Minister or Curate (having knowledge thereof) shall resort unto him or her (if the disease be not known or probably suspected to be infectious) to instruct and comfort them in their distress, according to the order of the Communion Book, if he be no Preacher, or if he be a Preacher, then as he shall think most needful and convenient." In the Ordination of Deacons it is also stated to be part of their duty to search out the sick and poor in the parish in which they are appointed to minister, and to give notice of such cases to the Incumbent: "And furthermore it is his office, where provision is so made, to search for the sick, poor and impotent people of the Parish, to intimate their estates, names and places where they dwell unto the Curate, that by his Exhortation they may be relieved with the alms of the Parishioners and others. Will you do this gladly and willingly?" This question, and the first parenthesis in the Canon (which speaks in general terms of the knowledge by the Minister of a case of sickness), imply that the Incumbent is expected to do something more than merely visit sick people who send for him. Whether he become acquainted with the case directly or indirectly, he is bound to visit, and even, if circumstances permit, he is to search for, or, at any rate, cause to be sought for, the sick and impotent, and to act up to the maxim quoted above, "Etiam si non vocatus." For giving

full force to this Visitation of the Sick, the English Ritual contains a formulary which has been used with slight alteration in our churches from the earliest times. Nearly all the rubrics and prayers are to be found in the ancient Manuals of the Church of England, and some of the prayers can be traced to almost primitive times. Where some variation has been made from these originals (as, for example, in the Exhortation, and in the substitution of a rubric directing the Minister to examine whether the Sick Man repent him truly of his sins, &c., for a somewhat lengthy form), the spirit of the original is still adhered to. The only portions which have been altogether omitted in our Prayer Book are the procession of the Priest and his Clerks to the house saying the seven penitential Psalms, and the Service of Extreme Unction. The original object of anointing with oil, as we see from the passage in St. James cited above, was to "save," or procure a miraculous recovery of the infirm, by remission of the temporal punishment which they had merited for their sins. Though it should also be added that Extreme Unction was used in very early times without any expectation of cure, *in extremis*: and it seems probable that there was a primitive ordinance of this kind which was used for the dying, as well as that which was used with a view to recovery. The Reformers retained the practice in the first Prayer Book, but it was dropped out of the second in 1552. The Office then in use is given in a note at the end of this Service.

An Appendix of four Prayers was added to the Visitation Office in 1661, to meet particular cases; the first for a sick child, the second for a sick person when there appears little hope of recovery, the third a Commendatio Animæ for a dying person, and the fourth a Prayer for one troubled in mind or conscience. These have not as yet been traced to any ancient source.

§ The Use of the Office.

The structure of the Office for the Visitation of the Sick shows that it is intended as a formal rite, to be once used over the Sick Person, and not to be used as the customary prayers of the Clergyman in his ordinary and frequent visits to the sick rooms of his parishioners. It is a solemn recognition of the person over whom it is used as one who is in the fellowship of the Church, and for whom the Church, by its authorized Minister, offers prayer to God; and it is also a solemn recognition of the fact that the sicknesses and infirmities incident to human nature are a consequence of sin, a part of that heritage of death which came upon us through the Fall.

The promiscuous use of the Office would evidently be a departure from the intention with which it is put into the hands of her priests by the Church of England. Their duties towards the sick divide themselves, indeed, into two distinct general branches, the one consisting of ordinary pastoral instruction, consolation, and prayer; and the other of the use of the two services for Visitation and Communion: and every clergyman must find him-

self obliged to exercise his discretion as to those cases in which he can adopt the more solemn course which the Church has appointed for him and his parishioners in the latter branch of his duties.

Those who really have any religious convictions, and who have made religious principles the rule of their life, will either be consistent Church people or religious Dissenters. The former are well accustomed to the system and services of the Church, and have been trained, consciously or unconsciously, by means of it: the latter are in more or less ignorance about the principles of the Church, and have not ordinarily been under its training influence. In the case of the one, the Visitation Service would be appropriate even if used on a sudden, supposing the case to be one of imminent danger; and no prayers could be used with so great advantage. To the other it would be like a strange language, if used without much preparation and instruction: and would not be applicable at all, except it were accompanied by an understanding that its use presupposed reconciliation to the Church.

In the case of other classes of persons, who have led irreligious and wicked lives, and who are ill instructed in the way of salvation, the Visitation Service can only be properly applicable after much instruction has been given, and much progress made towards penitence. An abrupt use of it might tend to bring into their view the comforts of the Office more prominently than would be advisable for those who do not fully appreciate the necessity of repentance towards the attainment of pardon and true peace.

It may be added, in conclusion, that the Visitation Office should be used with all the proper solemnity belonging to a formal rite of the Church. The first Rubric of the ancient Service was, "*In primis induat se sacerdos superpellicio cum stola . . .*," and the same rule should still be observed. Care should also be taken that there is some one present to say the responses. In his revised book, Bishop Cosin provided for this by so far reviving the ancient practice as to direct the attendance of one lay Clerk with the Priest. But some members of the sick person's family, or a parish visitor, or other friend, can always be found ready to take this charitable duty on themselves.

THE
ORDER FOR THE VISITA-
TION OF THE SICK.

"And the Priest
with his Clerk;
entering into,
Cassin's Dir-
ham Book.
James v. 14. 16.
Luke x. 5.

¶ *When any person is sick, notice shall be given thereof to the Minister of the Parish; who, coming into the sick person's house, shall say,*

PEACE be to this house, and to all that dwell in it.

¶ *When he cometh into the sick man's presence he shall say, kneeling down,*

Exod. ix. 5.
Ps. lxxix. 8.
Neh. xiii. 22.
1 Pet. i. 18, 19.
Ps. xxxix. 13.

REMEMBER not, Lord, our iniquities, nor the iniquities of our forefathers. Spare us, good Lord, spare thy people whom thou hast redeemed with thy most precious blood, and be not angry with us for ever.

Answer.

Spare us, good Lord.

¶ *Then the Minister shall say,*

Let us pray.

Lord, have mercy upon us.

Christ, have mercy upon us.

Lord, have mercy upon us.

Matt. xx. 30.

ORDO AD VISITANDUM
INFIRMUM.

¶ *Et cum intraverit domum dicat,*

Salisbury Use.

PAX huic domui et omnibus habitantibus in ea: pax ingredientibus et egredientibus.

NE reminiscaris, Domine, delicta nostra, vel parentum nostrorum: neque vindictam sumas de peccatis nostris: parce, Domine, parce famulo tuo: quem redemisti precioso sanguine tuo ne in æternum irascaris ei.

Et statim sequatur.

Kyrie eleison.

Christe eleison.

Kyrie eleison.

THE SALUTATION.

The Priest, on entering the house, is ordered to use the salutation enjoined by our Lord upon His Apostles: "And into whatsoever house ye enter, first say, Peace be to this house" [Luke x. 5]. It is specially appropriate when thus pronounced by the Minister of God on entering a house of sickness. In a household so circumstanced there is often much of disquietude and anxiety. The relations are perplexed and agitated, inclined to forget, perhaps, that this sickness is of the Lord. The words of the Priest remind them of that peace which is to be found in resting in the Lord, and casting their cares on Him. But the Salutation has a special reference to the sick man, to whom the Priest comes as the Messenger of Peace. He is very probably under deep conviction of sin, longing for pardon and reconciliation; and the object of this visitation is to strengthen his faith, awaken his charity, move him to sincere confession and repentance, and on his sincere repentance and confession to give him the free and full forgiveness vouchsafed by the Saviour to all who truly turn to Him, and so to make the sinner at peace with God.

These words, too, used at the very entrance of the Priest into the house, help to remind those who hear them that he comes on no ordinary errand of condolence, but specially in his character as a representative of Him Who said to His ministers, "My peace I leave with you." They thus serve to bring about a tone of mind in unison with the service that is to follow.

THE ANTHEM.

In the older Service Books the Priest and his Clerks were directed, on their way to the house of the sick man, to say the seven Penitential Psalms, with the Gloria Patri after each, and to conclude with the Antiphon, "Ne reminiscaris."

In the Prayer Book of 1549 one of the penitential Psalms, the 143rd, was said by the Priest on entering the sick man's presence, followed by the Gloria Patri and this anthem, "Remember not," &c. Subsequently the Psalm was omitted, and the anthem, "Remember not," alone retained. The Respond, "Spare us, good Lord," was added at the last revision in 1661.

* This Antiphon memorializes God of the redemption of His people by the most precious blood of Christ. To those present in the sick room, as well as to the sick person himself, it also gives the key-note of the Service at its very beginning: pointing out that sickness is a chastisement permitted by God; that sin has brought it into the world; and that our prayers for benefits to the body ought to be founded on the confession of God's undeserved mercy in Christ. The words are, of course, spoken to God, and are a kind of Litanic hymn; but they cannot fail to have a subjective side also in warning the sick of their true relation to His mercy, and of the worthlessness as well as impiety of self-reliance. They remind him that God's mercy must be sought; that His anger against sin is often shown by bodily chastisement; and that temporal judgments are frequently sent by Him in

OUR Father, which art in heaven,
Hallowed be thy Name. Thy
kingdom come. Thy will be done in
earth, As it is in heaven. Give us
this day our daily bread. And forgive
us our trespasses, As we forgive them
that trespass against us. And lead us
not into temptation;—But deliver us
from evil. Amen.

Minister.
Ps. lxxxvi. 2. O Lord, save thy servant;
Answer.
Which putteth *his* trust in thee.
Minister.
Ps. xx. 1, 2. Send *him* help from thy holy place,
lxxix. 9. *Answer.*
And evermore mightily defend *him*.
Minister.
Ps. lxxxix. 22, 23. Let the enemy have no advantage
of *him*;
Answer.
Nor the wicked approach to hurt
him.
Minister.
Ps. lxi. Be unto *him*, O Lord, a strong tower,
Answer.
Prov. xviii. 10. From the face of *his* enemy.
Minister.
Ps. lxi. 1. O Lord, hear our prayers.
Answer.
Ps. cii. 1. And let our cry come unto thee.
Minister.
Ps. lxxx. 14. **O** LORD, look down from heaven,
cvi. 4. behold, visit and relieve this thy
1 Pet. iii. 12. servant. Look upon *him* with the
Isa. lxiv. 1.
Matt. v. 4.

PATER noster, qui es in cœlis;
sanctificetur nomen tuum: ad-
veniat regnum tuum: fiat voluntas
tua, sicut in cœlo, et in terra. Panem
nostrum quotidianum da nobis hodie:
et dimitte nobis debita nostra, sicut et
nos dimittimus debitoribus nostris: et
ne nos inducas in tentationem: sed
libera nos a malo. Amen.

V. Salvum fac servum tuum *vel*
ancillam tuam.

R. Deus meus sperantem in te.

V. Mitte ei, Domine, auxilium de
sancto.

R. Et de Syon tuere eum.

V. Nihil proficiat inimicus in eo.

R. Et filius iniquitatis non apponat
nocere ei.

V. Esto ei, Domine, turris fortitu-
dinis.

R. A facie inimici.

V. Domine, exaudi orationem meam.

R. Et clamor meus ad te veniat.

Oremus.

RESPICE, Domine, de cœlo, et
vide et visita hunc famulum
tuum V. et benedic eum sicut benedi-

mercy, that He may not be compelled to be "angry with us for ever."

THE LORD'S PRAYER.

The prayer of our Blessed Lord is used here, as elsewhere, at the beginning of the Service in token of its prevailing power with God, and as the gate by which all other prayer is to enter into Heaven, and be heard by Him. The structure of the Service suggests that it should be said by all present as well as by the Priest, and "with" him, as in the end of the Litany. It should also be said with a special intention directed towards the subsequent portion of the Service, remembering that God is Our Father to chastise and Our Father to heal, that "He woundeth, and His hands make whole:" and that the first prayer of the sick and of those who love them should be in the tone of His Whose holy example teaches us to say "Thy will be done."

The lesser Litany precedes the Lord's Prayer in this place with a special emphasis, for it is the very language of those who came to Jesus to be healed of their infirmities in the days of His earthly life. Thus the two blind men mentioned in St. Matthew ix. came to Christ, "crying and saying, Thou Son of David, have mercy upon us;" and in like manner the two mentioned in St.

Matthew xx., "cried out, saying, Have mercy on us, O Lord, Thou Son of David." In almost the same terms the father prayed for his lunatic son, "saying, Lord, have mercy on my son" [Matt. xvii. 15]; and the woman of Syro-Phœnicia, who came to Jesus on behalf of her sick daughter, "cried unto Him, saying, Have mercy on me, O Lord."

THE VERSICLES.

These suffrages are the same which are used throughout the Occasional Offices, slight variations being made in them according to the nature of the service in which they are introduced. They are taken from the 20th, the 61st, the 86th, and the 89th Psalms; and represent a strain of responsive supplication which has been ascending to the Throne of God for the sick, during as many ages as the service itself can be traced back.

THE PRAYERS.

In the Sarum Manual, immediately after the responses follow nine collects, two of which only have been translated, and retained in our present service. The collect now standing first was the

Isa. xxvi. 3.

eyes of thy mercy, give *him* comfort and sure confidence in thee, defend *him* from the danger of the enemy, and keep *him* in perpetual peace and safety, through Jesus Christ our Lord.

Amen.

Job viii. 5, 6.
Ps. cxvi. 3, 4.
Heb. xii. 6—11.
Job vii. 20. xlii.
5, 6.
Ps. xl. 16. xxxix.
18. cxvi. 9, 12,
13.
Job xix. 25, 27.
1 Thess. iv. 14, 17.

HEAR us, Almighty and most merciful God and Saviour; extend thy accustomed goodness to this thy servant who is grieved with sickness. Sanctify, we beseech thee, this thy fatherly correction to *him*; that the sense of *his* weakness may add strength to *his* faith, and seriousness to *his* repentance. That, if it shall be thy good pleasure to restore *him* to *his* former health, *he* may lead the residue of *his* life in thy fear, and to thy glory: or else give *him* grace so to take thy visitation, that after this painful life ended *he* may dwell with thee in life everlasting, through Jesus Christ our Lord. Amen.

cere dignatus es Abraham, Isaac, et Jacob. Respice super eum, Domine, oculis misericordiae tuae: et reple eum omni gaudio et lætitia et timore tuo. Expelle ab eo omnes inimici insidias: et mitte Angelum pacis qui eum custodiat, et domum istam, in pace perpetua. Per Dominum nostrum.

Oremus.

EXAUDI nos, omnipotens et misericors Deus, et visitationem tuam conferre digneris super hunc famulum tuum *N.* quem diversa vexat infirmitas. Visita eum, Domine, sicut visitare dignatus es socrum Petri, puerumque centurionis, et Tobiam, et Saram, per sanctum angelum tuum, Raphaellem. Restitue in eo, Domine, pristinam sanitatem: ut mereatur in atrio domus tuae dicere, castigans castigavit me Dominus, et morti non tradidit me: Salvator mundi. Qui cum Deo Patre, et Spiritu Sancto vivis et regnas Deus: per omnia sæcula sæculorum. Amen.

last of this series. In the original, mention is made of God's blessing on Abraham, Isaac, and Jacob, and it is prayed that God in like manner will visit and bless His servant. This clause has been omitted in translation. The sentence which opens the collect is doubtless originally derived from Deut. xxvi. 15, "Look down from Thy holy habitation, from heaven, and bless Thy people Israel;" a form which, if we may judge from Isaiah lxiii. 15, was long in use in the Jewish Church.—"Look down from heaven, and behold from the habitation of Thy holiness and of Thy glory." Solomon in like manner prayed at the Dedication of the Temple,—"Whatsoever sickness there be . . . then hear Thou in heaven Thy dwelling-place, and forgive. . ."

The object of the Prayer is to beg God's help on behalf of the sick man. It asks that the Lord would look on him in mercy, not remembering his sins, but considering his weakness; that He would be pleased to comfort him under his trial, and enable him to have firm faith in God. Not only does it ask that the Almighty will remember him for good, but that He will defend him from the evil, specially that He will guard him against the assaults of the Devil, that He will grant him perpetual peace, and ever keep him in safety.

If we compare this prayer and the preceding versicles, we shall see how naturally the collect re-echoes what has been already prayed for. It gathers up into a connected whole all the previous petitions, and again lays them before God. This is no idle repetition: the blessings sought are of so great value, and so deeply needed, that the Church purposely enables us here to set them once and again before God, according to the example of our Blessed Lord, Who in the hour of His distress prayed thrice, using the same words: "If it be possible, let this cup pass from Me; yet not My will, but Thine."

The next prayer is the third of the group of collects in the Sarum Manual. In the original prayer, mention is made of the miraculous cure of Peter's wife's mother and of the centurion's servant, of Tobias and of Sara, which allusions were all omitted

at the last revision in 1661. The former prayer is directed to seeking comfort and help for the sick man from God in the time of his affliction; this second collect sets forth sickness as an instrument in the hand of the Almighty for good, and prays that the present trial may be sanctified to the sufferer. The "accustomed goodness" of God is here invoked, not for the recovery of the patient, or even for support under trial, but that the fatherly correction may work the end God has intended in sending it. If sickness is to answer any good end, it must be viewed as Fatherly correction; and, if it comes from our Father, to Him we may go for help and comfort under it, and we may be persuaded that it comes for some good purpose. Looking to God as Father, our own weakness will lead us more to Him, will make us feel our dependence on Him more; in short, will strengthen our faith. The sense of weakness will force on us the uncertainty of life, will make us remember how short our time is, and bring us to more earnest repentance for all we have done amiss, as remembering the account we may so soon have to give before our God. The prayer, too, reminds those who hear it, that the repentance and sorrow are not to be limited simply to a sick bed, but that in case of recovery the good work begun in time of affliction must be carried out. How necessary to pray, "If it shall be Thy good pleasure to restore him to his former health, he may lead the residue of his life in Thy fear!" How many are there who promise well when God's hand is upon them, who seem full of godly sorrow for sin, and Christian hatred of it, who yet on recovery forget all, and fall back into old sins, and form new evil habits!

And since the issues of life and death are with the Lord, and we know not what the event may be, recovery or death, the Collect prays, not only that in case of restoration the sick man may be enabled to live to God, but that in case his illness prove fatal, he may, through the grave and gate of death, pass to a joyful resurrection, and, this life ended, dwell for ever with God in life everlasting.

¶ Then shall the Minister exhort the sick person after this form, or other like.

Deut. iv. 39.
xxxii. 39, 40.
Job xii. 9, 10.
v. 6.
Ps. xlii. 11. cii.
23.
James i. 2—4.
2 Cor. iv. 17, 18.
1 Pet. i. 6, 7, 9.
Ps. xxxix. 11.
lxxxix. 36, 32,
33.
Rev. iii. 19.
Job xxxiv. 31, 32.
Micah vii. 9.
1 John ii. 1, 2.
Ps. xvi. 8.
Heb. xii. 10, 11.
James i. 12.

DEARLY beloved, know this, that Almighty God is the Lord of life and death, and of all things to them pertaining, as youth, strength, health, age, weakness, and sickness. Wherefore, whatsoever your sickness is, know you certainly that it is God's visitation. And for what cause soever this sickness is sent unto you, whether it be to try your patience for the example of others, and that your faith may be found in the day of the Lord laudable, glorious, and honourable, to the increase of glory and endless felicity; or else it be sent unto you to correct and amend in you whatsoever doth offend the eyes of your heavenly Father; know you certainly that if you truly repent you of your sins, and bear your sickness patiently, trusting in God's mercy, for his dear Son Jesus Christ's sake, and render unto him humble thanks for his Fatherly visitation, submitting yourself wholly unto his will, it shall turn to your profit,

and help you forward in the right way that leadeth unto everlasting life.

¶ If the person visited be very sick, then the Curate may end his exhortation in this place, or else proceed.

TAKE therefore in good part the chastisement of the Lord: For (as Saint Paul saith in the twelfth Chapter to the Hebrews) whom the Lord loveth he chasteneth, and scourgeth every son whom he receiveth. If ye endure chastening, God dealeth with you as with sons; for what son is he whom the father chasteneth not? But if ye be without chastisement, whereof all are partakers, then are ye bastards, and not sons. Furthermore, we have had fathers of our flesh, which corrected us, and we gave them reverence: shall we not much rather be in subjection unto the Father of spirits, and live? For they verily for a few days chastened us after their own pleasure; but he for our profit, that we might be partakers of his holiness. These words, good *brother*, are written in holy Scripture for our comfort and in-

Prov. iii. 11.
Heb. xii. 6—10.

Rom. xv. 4.
2 Tim. iii. 16.
Ps. cxix. 49, 50.
111.
1 Sam. iii. 18.

THE EXHORTATIONS.

The use of Exhortation after Prayer has long formed part of the Service in the Western Church. The principal heads of the Exhortation as given in our Prayer Book are prescribed by an ancient Canon, in which the Priest is ordered, after he hath prayed for the sick, "to speak comfortably and mildly to him, exhorting him to place all his hope in God, and to bear his scourging patiently; to believe it is designed for his purifying and amendment, and also to confess his sins, and promise reformation if God grant him life, and that he engage to do acts of Penance for his faults; also that he dispose of his estate while his reason and senses remain entire; that he break off his iniquities by Almsdeeds; that he forgive all that have offended him; that he hold a right Faith and Belief, and never despair of God's mercy." [Concil. Nannetens. cap. 4, ap. Binjum, Tom. 3, p. 2, pag. 131.] In the Sarum Manual the first form of Exhortation, which probably in some measure suggested the two exhortations here set forth, is but short:—"Frater charissime, gratias age omnipotenti Deo pro universis beneficiis suis: patienter et benigne suscipiens infirmitatem corporis quam tibi Deus immisit: nam si ipsam humiliter sine murmure, toleraveris, infert animæ tuæ maximum præmium et salutem. Et frater charissime quia viam universæ carnis ingressurus es; esto firmus in fide. Qui enim non est firmus in fide infidelis est: et sine fide impossibile est placere Deo. Et ideo si salvus esse volueris: ante omnia opus est ut teneas catholicam fidem: quam nisi integram inviolatamque servaveris: absque dubio in æternum peribis."

Some traces of similarity with our own form may also be found in a mediæval exhortation of early date, given by Maskell. It is taken from an ancient MS., *De Visitatione Infirmorum*, in the Library of St. John's College, Oxford:—

"How thou shalt comfort a man that he grucche nouȝt when he is seke.

"Some loueste thou thi Lord God? he will sai, ȝc. Than thus,

if thou loue God, thou louest that He doith, and He skorgeth the, and therfor thou shalt gladi suffre it. Here of spekit Salamon, and seith, Sone speke nouȝt aȝen the chastising of thi fader, for it is no some whom the fadir chastisith nouȝt, and it accordith with commine maner of speche. For if a man see another's child do schrendeli in his fader presence, and the fader chastised him nouȝt, than wold that othir man seie, it is nouȝt his sone, or ellis he loueth him nouȝt, for if he were his child or ellis loued him, he wold chastise him: and therfor he nouȝt evil afraid of thi Faders chastising of hevene; for he seith himself; whom I loue, him I chastise. Also sekene of bodi makith soule hele, and soule hele is nouȝt but of God; therfor despice nouȝt Godis scorge, but whan God ponissche the, thanke him and loue him, that he emendith the, and undernemith the, and blameth the, and ponissche the nouȝt in his wrath ne in his wodnes, but in his grete mercy. . . ." [Mon. Rit. iii. 354.]

The Exhortation, as set forth in our service, is divided into two portions, whereof the second part may be omitted, if the person visited be very sick. The first part is devoted to Instruction regarding the cause of sickness, and the purpose of it as concerns the sufferer. The second portion is purely hortatory, exhorting to patience, self-examination, and faith. In the earlier portion the sick man is reminded that all things are of God, as life, death, health, and sickness. Whatever his trial may be, it is God's visitation. If from the Lord, it comes with some definite end and purpose, for the Almighty does not work at random. The object may be the trial of his patience for the example of others, that they may see in the sick man visible proof of God's sustaining grace, and be brought to seek it for themselves; or that his faith may be tried, to see of what sort it is, whether it will endure in the furnace of affliction; or that he may be moved to see his sins, and the need of repentance and amendment of life. One or other of these, or a combination of all, may be the end purposed by God; but although we may not be able to see clearly the cause for which the sickness is sent, one thing is certain,

Phil. i. 24.
 2 Cor. xii. 9, 10.
 1 Pet. iv. 19.
 2 Thess. ii. 16.
 Heb. v. 8, 9.
 xii. 2.
 2 Cor. xiii. 4.
 John xiv. 6.
 2 Tim. ii. 11, 12.
 Rom. viii. 11, 18.
 Col. iii. 3, 4.
 Rev. vii. 14, 15.
 Ps. xl. 1.
 Lam. iii. 25, 26.
 1 Tim. vi. 12.
 Heb. iii. 14.
 Acts xvii. 21.
 x. 34.
 Hagg. i. 5.
 Lam. iii. 40.
 Ps. xxxii. 3, 5.
 1 John i. 9.
 1 Cor. xi. 32.
 Heb. x. 27.
 Rev. vi. 15, 16.
 2 Cor. xiii. 3.
 Ps. cxxxix. 23,
 24.

struction, that we should patiently, and with thanksgiving bear our heavenly Father's correction, whensoever by any manner of adversity it shall please his gracious goodness to visit us. And there should be no greater comfort to Christian persons, than to be made like unto Christ, by suffering patiently adversities, troubles, and sicknesses. For he himself went not up to joy, but first he suffered pain; he entered not into his glory before he was crucified. So, truly, our way to eternal joy is to suffer here with Christ; and our door to enter into eternal life is gladly to die with Christ; that we may rise again from death, and dwell with him in everlasting life. Now therefore taking your sickness, which is thus profitable for you, patiently, I

exhort you in the Name of God, to remember the profession which you made unto God in your baptism. And for as much as after this life there is an account to be given unto the righteous Judge, by whom all must be judged without respect of persons; I require you to examine your self and your estate, both toward God and man; so that accusing and condemning your self for your own faults, you may find mercy at our heavenly Father's hand for Christ's sake, and not be accused and condemned in that fearful judgement. Therefore I shall rehearse to you the Articles of our Faith, that you may know whether you do believe as a Christian man should, or no.

¶ *Here the Minister shall rehearse the Articles of the Faith, saying thus,*

DOST thou believe in God the Father Almighty, Maker of heaven and earth?

And in Jesus Christ his only begotten Son our Lord? and that he was conceived by the holy Ghost, born of the Virgin Mary; that he suffered under Pontius Pilate, was crucified, dead, and buried; that he went down

¶ *Et si infirmus laicus vel simpliciter literatus fuerit: tunc potest sacerdos articulos fidei in generali ab eo inquirere, sub hac forma.*

CARISSIME frater: credis Patrem et Filium et Spiritum Sanctum, esse Tres Personas et Unum Deum, et ipsam benedictam atque indivisibilem Trinitatem creasse omnia creata visibilia et invisibilia. Et solum Filium, de Spiritu Sancto conceptum, incarnatum fuisse ex Maria Virgine: passum et mortuum pro nobis in cruce sub

that if it be accepted in a right spirit, it will turn to the good of the sufferer. If he truly repent him of his sins, if he bear his sickness patiently, trusting in God's mercy through Christ,—nay more, if, strong in faith, he is able to see goodness in this fatherly visitation, and to thank God for it; then, whether he recover or whether he die, the sickness shall turn to his profit. If he recover, health will find him strengthened, established in the faith, earnest to run his Christian race, to press forward toward the mark of the prize of his high calling in Christ Jesus, with deeper love to his Lord and firmer faith. If he die, there will be ministered unto him, through the grace of God, an entrance into life eternal.

The second part is founded, as far as the earlier portion of it is concerned, on Hebrews xii. 6—10. These words are set before the sick man as an argument for patience under the chastening hand of God. He is reminded, too, of the example of Christ. The Christian before all things should long to be as his Master, Who going through sorrow and pain on earth, entered not into His glory until after His agonizing death on the cross. They who would share the blessedness of Christ must be willing to take up the cross when it is set before them, and follow Him in the path of suffering.

It is also observable that the continued obligation of the vows made in Baptism is set before the sick person; and that these vows are spoken of as the substantial matter on which that Judgment will be founded which mortal sickness so vividly brings into view. Thus the Christian system is shown to us, consistent

with itself in all its parts, as is the Christian revelation: and when a person is lying on a sick bed in expectation of death, he is forcibly reminded by the ministrations of the Church to him that the life of this world is, in its spiritual reality, a preparation for a life to come with which it is intimately associated.

THE PROFESSION OF FAITH.

In the ancient English Office the Priest is directed to recite to the sick man the fourteen articles of the faith, of which the seven first relate to the mystery of the Trinity, and the seven others to the humanity of Christ. After these articles it is, however, added, "And if the sick man be a laic or simply a literate, then the priest may question him generally on the articles of the faith under this form." The form prescribed in this case is simply the Creed slightly paraphrased.

Maskell cites a form of examination from the MS. *De Visitatione Infirmorum*, already quoted. Part of it is: "Whan thou hast told him alle this, or ellis if thou haue no time to sai alle for hast of deth, begin here, and speke to him on this maner, whan thou seest that he neieth the deth. Brother, art thou glad that thou shalt die in Christin feith? Resp. Ʒe. Knowleche that thou hast nouȝt wel liued as thou shuldest? Resp. Ʒe. Art thou sori therfor? Resp. Ʒe. Hast thou wil to amende the, if thou haddist space of lif? Resp. Ʒe. Leuist thou in God, Fader Almighty, Maker of heuene and erthe? Resp. Ʒe. Leuist thou in the Fader and the Sone and the Holi Gost thre persons and on

into hell, and also did rise again the third day; that he ascended into heaven, and sitteth at the right hand of God the Father Almighty, and from thence shall come again at the end of the world, to judge the quick and the dead?

And dost thou believe in the holy Ghost, the holy Catholick Church, the Communion of Saints, the Remission of sins, the Resurrection of the flesh, and everlasting life after death?

¶ *The sick person shall answer,*

All this I stedfastly believe.

Mark ix. 24.

2 Cor. xii. 5.
Matt. vi. 14, 15.
Numb. v. 6—10.

¶ *Then shall the Minister examine whether he repent him truly of his sins, and be in charity with all the world; exhorting him to forgive from the bottom of his heart all persons that have offended him, and if he hath offended any other, to ask them forgiveness; and where he hath done injury or wrong to any man, that he make amends to the uttermost of his power. And if he hath not before disposed of his goods, let him then be admonished to make his will, and to declare his debts, what he oweth, and what is owing unto him, for the better discharging of his conscience, and the quietness of his executors. But men should often be put in remembrance to take order for the settling of their temporal estates, whilst they are in health.*

Eccles. vii. 14.
Isa. xxxviii. 1.

¶ *These words before rehearsed may be said before the Minister begin his prayer, as he shall see cause.*

Matt. xxv. 31—46.
Luke xvi. 9—12.
Lev. v. 5.
Josh. vii. 19.

¶ *The Minister should not omit earnestly to move such sick persons as are of ability, to be liberal to the poor.*

Pontio Pilato: sepultum descendisse ad inferna: die tertia resurrexisse a mortuis: ad caelos ascendisse: iterumque venturum ad iudicandum vivos et mortuos, omnesque homines tunc in corpore et anima resurrecturos, bona et mala secundum merita sua recepturos. Et remissionem peccatorum per sacramentorum ecclesiae perceptionem. Et sanctorum communionem: id est, omnes homines in caritate existentes, esse participes omnium bonorum gratiae quae fiunt in ecclesia: et omnes qui communicant cum iustis hic in gratia, communicare cum eis in gloria?

¶ *Deinde respondeat infirmus,*

Crede firmiter in omnibus

¶ *Deinde dicat sacerdos.*

CARISSIME frater: quia sine caritate nihil proderit tibi fides, testante Apostolo qui dicit: Si habuero omnem fidem ita ut montes transferam, caritatem autem non habuero, nihil sum: Ideo oportet te diligere Dominum Deum tuum super omnia ex toto corde tuo, et ex tota anima tua: et proximum tuum propter Deum sicut te ipsum: nam sine huiusmodi caritate nulla fides valet. Exerce ergo caritatis opera dum vales: et si multum tibi affuerit, abundantè tribue: si autem exiguum, illud impartiri stude. Et ante omnia si quem injuste læseris, satisfacias si valeas: sin autem, expedit ut ab eo veniam humiliter postules. Dimitte debitoribus tuis et aliis qui in te peccaverunt, ut Deus tibi dimittat.

Salisbury Use.

God? Resp. ꝑe. Leuist thou that oure Lord Jesus Crist Godis Sone of heuene was conseiuid of the Holi Gost, and toke flesche and blode of oure ladi seint Marie, and was borne of hir, she being moder and mayde? Resp. ꝑe. Leuist thou that he suffrid pine and deth, for oure trespas, and nouȝt for his gilt under Pounce Pilate, and that he was don on the cros, and died for the on god Fridai, and was buried? Resp. ꝑe. Thankest thou him therfor? Resp. ꝑe. Leuist thou that thou may nouȝt be sauide but throw his deth? Resp. ꝑe." [Mon. Rit. iii. 357, q. v.]

In our Prayer Book the Creed simply has been retained as containing all things necessary to be believed by a Christian man, and on account of its great conciseness, an important point to be considered in selecting or composing a form for use in time of sickness and consequent weakness. In the case of ignorant persons there should be some previous instruction in the doctrines of the Creed before the Visitation Office is used, and this profession of faith thus solemnly made. A concise exposition of it will be found in the Notes to Morning Prayer, p. 20.

Then shall the Minister examine] In the Sarum Manual, after the patient's confession of faith, there follows a long exhorta-

tion to charity (grounded on 1 Cor. xiii.), to make amends for injuries done, to forgive injuries received, to love of enemies, to firm hope and faith in God, to confession of sin; and after the special confession the priest is directed to use an exhortation to almsgiving and good deeds and to works of penance in case of recovery. The Exhortation directed by the various rubrics that follow the confession of faith in our service is to be singular in its general character. In addition, however, to moving the sick man to repent him truly of his sins, to be in love and charity with all men, and to make amends to the uttermost of his power if he have wronged any, the priest is directed to admonish him, if he hath not before disposed of his property, to make his will. This may seem at first sight to be too purely a secular matter to find place in a death-bed exhortation. Yet when we reflect what heart-burning and jealousy is often caused by the fact of no disposition of property having been made, and when we remember that from this very cause families are often broken up and relations estranged, we can see at once that it is a part of the duty of the minister of Christ to do his utmost to prevent such a state of things. After having counselled the sick man to make a just

¶ *Deinde stabilito sic infirmo in fide, caritate, Salisbury Use. et spe dicat ei sacerdos,*

CARISSIME frater: si velis ad visionem Dei pervenire, oportet omnino quod sis mundus in mente et purus in conscientia: ait enim Christus in evangelio: Beati mundo corde, quoniam ipsi Deum videbunt. Si ergo vis mundum cor et conscientiam sanam habere, peccata tua universa confitere. . . .

¶ *Here shall the sick person be moved to make a special confession of his sins, if he feel his conscience troubled with any weighty*

and equitable provision for his family or relations, the priest is directed earnestly to move him to be liberal to the poor. First, he is exhorted to consider how his affairs stand, then to be charitable, that in his giving there may be no injustice to those who have prior claims upon him either by debt or relationship. It has always been the custom of the Church to stir up men to liberality in time of sickness: it is supposed that the heart at such a season will be most readily touched with sympathy for the sorrows of others, therefore specially at such times are men exhorted by the Church, "To do good and to communicate forget not, for with such sacrifices God is well pleased¹."

THE CONFESSION OF SINS.

Here shall the sick person] This rubric is, as will be seen, an abbreviated form of the ancient Latin rubric and exhortation. Its transition from the ancient to the modern form may be further illustrated by the following comparison:—

1549.	1552.	1661.
Here shall the sick person make a special confession, if he feel his conscience troubled with any weighty matter. After which confession the Priest shall absolve him	Here shall the sick person make a special confession, if he feel his conscience troubled with any weighty matter. After which confession the Priest shall absolve him	Here shall the sick person be moved to make a special confession of his sins, if he feel his conscience troubled with any weighty matter. After which confession the Priest shall absolve him (if he humbly and heartily desire it) after this sort.
after this form: and the same form of absolution shall be used in all private confessions.	after this sort.	after this sort.

The parenthesis in the last form of this rubric was introduced by Bishop Cosin, who has written it in the margin of the Durham book.

It is plain that the kind of Confession named in this Rubric is that which is popularly known as "Auricular" Confession; for although privacy is not enjoined, it is quite certain that it would be sought both by Priest and penitent, and that without it the

¹ Great caution should, however, be used in carrying out these duties. Dying persons are not only susceptible in respect to true Christian charity and justice; but they are also open to impressions from fear, sentiment, and other influences incidental to their state of prostration. In acting upon this rubric, therefore, the Clergyman should rather use exhortations of a general character, stating principles, than any which descend into detail. It may also be remarked that he should assist in making a will only in cases where a more proper person cannot be found in time.

Confession would most likely be of a very general, instead of a "special" character. That it is also intended to be private or "auricular,"—spoken to the ear of the Priest alone,—is shown by the original form of the Rubric in 1549, which speaks of "all private confessions" with an evidently inclusive sense,—this here enjoined being one of the kind included.

Before proceeding further, it may be well to inquire, what references to private confession are to be found in the official documents of the Church of England, in addition to the one now before us. The most familiar is that at the close of the exhortation directed to be used by the Minister when giving warning of the celebration of the Holy Communion: "And because it is requisite, That no man should come to the Holy Communion, but with a full trust in God's mercy, and with a quiet conscience; therefore if there be any of you, who by this means cannot quiet his own conscience herein, but requireth further comfort and counsel, let him come to me, or to some other discreet and learned Minister of God's Word, and open his grief; that by the ministry of God's Holy Word he may receive the benefit of absolution, together with ghostly counsel and advice, to the quieting of his conscience, and avoiding of all scruple and doubtfulness." The 113th Canon also refers to the subject; enjoining secrecy on the Minister in respect to all confessions confided to him:

"Provided always, That if any man confess his secret and hidden sins to the Minister, for the unburdening of his conscience, and to receive spiritual consolation and ease of mind from him, we do not any way bind the said Minister by this our Constitution, but do straitly charge and admonish him, that he do not at any time reveal or make known to any person whatsoever, any crime or offence so committed to his trust and secrecy (except they be such crimes as by the Laws of this Realm his own life may be called in question for concealing the same) under pain of irregularity²."

And, lastly, in the second part of the Homily of Repentance it is said, "If any do find themselves troubled in conscience, they may repair to their learned curate or pastor, or to some other godly learned man, and show the trouble and doubt of their conscience to them, that they may receive at their hand the comfortable salve of God's Word."

These quotations might be illustrated by many cases recorded in the lives of good Churchmen and Churchwomen of the last and previous centuries, in which private Confession was used both in health and sickness; and numberless practical writers speak of it as a recognized habit in the Church of England since the Reformation as well as before³. Nearly all such writers, however,

² The force of this Canon is apparently weakened by the indefinite character of the last word in the quotation, as used in modern times. In ecclesiastical law "irregularity" means *deprivation*, accompanied by a perpetual incapacity for taking any benefice whatever. It is the severest punishment which can be inflicted on a Clergyman under the Canon law, short of degradation from his Orders.

³ An interesting document has lately come to light among the papers of

matter. After which confession, the Priest shall absolve him (if he humbly and heartily desire it) after this sort.

2 Cor. v. 18. 20.
John xx. 23.
Matt. xxviii. 18.
20.
Acts xx. 21.
2 Cor. ii. 10.
Acts x. 43.
Numb. vi. 27.

OUR Lord Jesus Christ, who hath left power to his Church to absolve all sinners who truly repent and believe in him, of his great mercy forgive thee thine offences: And by his authority committed to me, I absolve

¶ *Deinde absolvat sacerdos infirmum, ab omnibus peccatis suis, hoc modo dicens,*

DOMINUS noster Jesus Christus pro sua magna pietate te absolvat: et ego auctoritate ejusdem Dei et Domini nostri Jesu Christi, et beatorum Apostolorum Petri et Pauli, et auctoritate mihi tradita, absolvo te ab omni-

protest against its compulsory injunction; and it does not seem to be proved that frequent and habitual Confession has ever been very common in the Church of England since the Reformation.

Having to deal here only with cases of sickness, the question comes before us, What is a clergyman's duty under the circumstances indicated by the Visitation Office?

It is plain that we cannot say, he must press no one, but must simply be willing, if confession is volunteered, to hear it; for the rubric expressly says, "Then shall the sick person be moved," and the addition was made in 1661. Still the Church interposes a condition, "if he feel his conscience troubled with any weighty matter," which implies that only in special cases, even in

Grenville, Dean of Durham, and son-in-law to Bishop Cosin. The papers referred to are in the Bodleian Library: Rawlinson MS. Miscell. 1109. They are also published by the Surtees' Society. The Dean writes as follows:

"We having no directions given by the Church for private Confession and Absolution, but what is in the Office for the Sick, as to the manner of performance, we ought to proceed in that method, for the matter of examination, as far as *time*, and *place*, and *person* will permit.

The form of Absolution is there set down, and therefore ought to be retained, but as for the form of prayers before or after, it is left to the discretion of the Minister. And accordingly several Ministers have several ways and methods of performance of it; more or less to edification.

The rule of the Apostle,—*let all things be done to edification*, ought to guide priests in this, and all other performances.

Being moved thereto by these considerations and the practice of the most godly and eminent Divines under whom I have had my edification, I do make use of the form following:

BEGIN first with the LORD'S PRAYER, saying together: **OUR FATHER** which art, &c.

Vers. O LORD, open Thou our lips.

Ans. And our mouth shall show forth Thy praise.

Vers. O GOD, make speed to save us.

Ans. O LORD, make haste to help us.

Glory be to the FATHER, &c.

As it was in the beginning, &c.

Then recite together Psalm 139, *Domine probasti*,—O LORD, Thou hast searched me out and known me, &c.

After this is said the Priest takes his place in his chair, and requires the penitent to kneel down before him, and to answer sincerely in the Name and fear of God to such questions as he shall by Christ's authority demand of him.

It is expedient and thought good for the ease and encouragement of the penitent to have some form of examination and answers given to him some convenient time before to consider of for the greater profit of his soul, and better preparation for so solemn a duty.

Then let the penitent repeat one of the forms of Confession after the Priest, with due deliberation and intention. After which the Priest rising up shall add, O LORD, I beseech Thee, &c., and then solemnly pronounce that excellent form of Absolution, **OUR LORD JESUS CHRIST**, &c.

Then let the Priest pronounce such sentences of Scripture as he conceives most to edification. Reciting afterwards on their knees together Psalm 32, Blessed, &c., concluding with these following prayers:

Let us pray.

1. O most merciful God, who according to the multitude of Thy mercies, &c., with some few alterations.

Or,

O most mighty God and merciful Father, &c.

2. LORD, we beseech Thee give us grace to withstand, &c.

3. O LORD, who knowest that all our doings are nothing worth, &c.

4. LORD, we pray Thee that Thy grace, &c.

ALMIGHTY GOD, the fountain of all wisdom, &c.

Benediction."

A long paper of questions is appended which appears to have been used by Grenville for some person who came to him habitually for Confession.

time of sickness, is confession to be urged as absolutely essential to the health of the soul.

A clergyman often meets with such special cases; where it is plain (for example) that the time is short, the sick man suffering from some severe accident probably soon to end in death, or lying under mortal sickness. He possibly knows little of the dying person's previous life, and even if he does know something of his outward conduct, he can hardly be acquainted with his secret sins. In such a case he could not take a more direct course towards promoting the dying man's peace with God, than by moving him to make a special confession of his sins, if his conscience be troubled with any weighty matter. Such a confession is almost the best proof we can have of a dying man's sorrow for sin, of his penitent mind, and of his desire for pardon. It is easy for him to say that he is "comfortable in his mind," or that "he is happy;" but such words are too often used by those who ought neither to be comfortable nor happy when the judgment is immediately before them. On the other hand, if a dying person opens out his sinfulness to the sorrowing gaze of Christ's minister, he does that which is extremely distasteful, and perhaps very painful, to himself; and does it with no other object than that by his humble confession he may gain the benefit of Christ's cleansing blood through the word of absolution pronounced by the Priest in his Master's Name.

It is most evident that where a person is thus desirous of unburdening his mind, (1) the Priest has no right to refuse to hear and receive such confession; and also that (2) the Priest is even bound to suggest and advise it as the remedy provided by the Church to those who are thus burdened.

The form in which Special Confessions are to be made is not laid down in the Prayer Book. The following is a common one:—"In the Name of the Father, and of the Son, and of the Holy Ghost. Amen. I confess to God the Father Almighty, to His only-begotten Son Jesus Christ our Lord, to God the Holy Ghost, and to you, father, that I have sinned exceedingly in thought, word, and deed, through my fault, through my most grievous fault. [Here comes in a statement of the sins troubling the person's conscience.] For these and all my other sins which I cannot now remember I humbly beg pardon of Almighty God, and grace to amend; and of you, my father, I ask [penance,] counsel, and absolution. And therefore I beseech God the Father Almighty, His only-begotten Son Jesus Christ, and God the Holy Ghost, to have mercy upon me, and you, father, to pray for me."

THE ABSOLUTION.

The substantial part of this Absolution is ancient, as will be seen by comparing it with the Latin original. A prefatory addition was made to it at the time of its translation in 1549; and this was taken from the Absolution in the "Order of Communion" of 1548, which, again, was derived from Archbishop Hermann's Consultation.

Daye's Transl. of Hermann's Consultation, 1547.

The Order of Communion, 1548.

Because our blessed Lord hath left this power to His congregation, that it may absolve them

Our blessed Lord, who hath left power to His Church to absolve penitent sinners from

thee from all thy sins, In the Name of the Father, and of the Son, and of the Holy Ghost. Amen.

bus peccatis his de quibus corde contritus et ore mihi confessus es: et ab omnibus aliis peccatis tuis de quibus si tuæ occurrerent memoriae libenter confiteri velles: et sacramentis ecclesiae te restituo. In nomine Patris, et Filii, et Spiritus Sancti. Amen.

¶ And then the Priest shall say the Collect following.

Let us pray.

Lam. iii. 41.
James iv. 8.
Ps. li. 1.
2 Sam. xii. 13.
Heb. viii. 12. x.
17.
1 Kings viii. 52.
Numb. xiv. 19.
Eph. iv. 22, 23.
Luke xxii. 31.
John xvii. 11. 20, 21.
1 Pet. i. 5, 6.
Ps. li. 17.
Isa. xxxviii.
2-5.
Ps. lxxi. 1, 2. xli.
3.
Eph. iii. 16.
Ps. xxxi. 5.
Rev. xiv. 13.
John xiv. 2, 3.

O MOST merciful God, who, according to the multitude of thy mercies, dost so put away the sins of those who truly repent, that thou rememberest them no more; Open thine eye of mercy upon this thy servant, who most earnestly desireth pardon and forgiveness. Renew in *him* (most loving Father) whatsoever hath been decayed by the fraud and malice of the devil, or by *his* own carnal will and frailness; preserve and continue this sick member in the unity of the Church; consider *his* contrition, accept *his* tears, asswage *his* pain, as

Oremus.

DEUS misericors, Deus clemens, qui secundum multitudinem miserationum tuarum peccata poenitentium deles, et praeteritorum criminum culpas venia remissionis evacuas: respice super hunc famulum tuum *N.*, sibi remissionem omnium peccatorum suorum tota cordis contritione poscentem. Renova in eo, piissime Pater, quicquid diabolica fraude violatum est: et unitati corporis ecclesiae tuae membrum infirmum, peccatorum percepta remissione, restitue. Miserere, Domine, gemituum ejus: miserere lachrymarum: miserere tribulationum atque

Salisbury Use.
Gelas. Reconciliationis ad mortem; in Martene de Antiq. Ecc. Rit. iii. 15.
Menard's Notes to Greg. Sacr. p. 353.
Muratori, i. 504.

from sins, and restore them into the favour of the heavenly Father, which being repentant for their sins, do truly believe in Christ the Lord, I the minister of Christ . . .

their sins, and to restore to the grace of the heavenly Father such as truly believe in Christ; Have mercy upon you . . .

the indicative part of the Absolution:—"And by His authority committed to me, I absolve thee," &c. Reverting again to the opening clause, we thus see that Christ has power on earth to forgive sins, which power He has deputed to His ministers; and since He has promised that He will forgive under certain conditions, it is subject to those conditions that His deputies dispense His pardon.

Like the two other Absolutions contained in the Prayer Book, this is intended to convey what it professes to convey, pardon of sin. That pardon cannot, however, be conveyed without the co-operation of the person to whom it is spoken. It is nullified by a false confession (even although the deception is not detected by the Priest), and by any act of sin which places a bar between the sinner and God's pardon. The Priest has acted, of course, to the best of his judgment in regard to the true penitence of the person over whom he pronounces the Absolution, but his judgment is human, and the eye of God alone can detect the full truth.

Thus, in this very solemn form of Absolution, the Priest acts ministerially throughout; that is, he acts as the instrumental agent for the declaration by an audible word, of that pardon which God will give by an inaudible sentence to the person who bows down to receive it with a faithful and penitent heart. To such it will be a true comfort; a word of pardon and a word of peace¹.

THE COLLECT.

It was probably with the object of making clear in the form of words itself, what relation the Priest stands in towards the penitent and towards the One Forgiver of sins, that the Name of our Lord Jesus Christ was placed in the very forefront of the Absolution. He, by His death, purchased remission of sin for all men; therefore He alone is the Judge of all, having the supreme power in Himself originally to save or to condemn. The right foundation being thus laid, the power delegated by Christ to His ministers is introduced. It is their part, first, to bring sinners to submit to Jesus; and, secondly, as His Ambassadors to reconcile them. But this reconciliation is only on certain fixed conditions, repentance and faith. Without these there can be no forgiveness; without evident tokens of these the Priest has no right or power to pronounce the Absolution; without these, even if the Absolution be pronounced by the Priest, there is no pardon. The Lord Jesus being set forth as the Author of all pardon, the authority of His ministers as derived from Him laid down, the conditions of forgiveness stated, the Petition follows that He will confirm in heaven what is done on earth, that He who is the Priest's Lord will forgive by His servant's ministry. Then follows

This ancient "reconciliation of a penitent near death" is not only found in the old formularies of the English Church, where it was used long before the preceding indicative form of Absolution was introduced, but in the Sacramentary of Gelasius, A.D. 494; and for many centuries it was commonly used in the churches of the West, as the marginal references show.

The Prayer opens with an appeal to the unfailing mercy of God in putting away the sins of those who truly repent, and remembering them no more: it then beseeches the pity of the Almighty on behalf of the sick man. From this the prayer rises to a petition for internal sanctification, praying that as by the frequent commission of sin, the desires have been biassed towards evil, the faith weakened, the heart hardened, the devotion

¹ There is a practical note, about the manner of giving Absolution, in the Salisbury Manual, which may be usefully annexed: "Et post absolutionem convenienter apponitur. 'In Nomine Patris, et Filii, et Spiritus Sancti. Amen.' Ad signandum, quod sacerdos non propria auctoritate absolvit: sed quasi minister: tamen hoc relinquitur sacerdotis arbitrio. Nec requiritur in absolutione manus impositio, quia hoc sacramentum non ordinatur ad exequendam aliquam excellentiam gratiae, sed remissionem culpae, et ideo magis competit crucis signatio, quia fuit instrumentum nostrae redemptionis." Manual. Sarisb. 1530. Mask. ii. 302.

shall seem to thee most expedient for *him*. And forasmuch as *he* putteth *his* full trust only in thy mercy, impute not unto *him* *his* former sins; but strengthen *him* with thy blessed Spirit, and when thou art pleased to take *him* hence, take *him* unto thy favour, through the merits of thy most dearly beloved Son Jesus Christ our Lord.
Amen.

¶ *Then shall the Minister say this Psalm,*

In Te, Domine, speravi.
Ps. lxxi. [vv. 1—17.]
[Printed at length in the Sealed Books.]

IN thee, O Lord, have I put my trust
Thy righteousness, O God, is very high, and great things are they that thou hast done : O God, who is like unto thee?

Glory be to the Father, and to the Son : and to the Holy Ghost ;
As it was in the beginning, is now, and ever shall be : world without end.
Amen.

¶ *Adding this,*

1 John iv. 14. ii. 1, 2.
Col. i. 20.
1 Pet. i. 18, 19.
Ps. cxvi. 3, 4.

O SAVIOUR of the world, who by thy cross and precious blood hast redeemed us, save us, and help us, we humbly beseech thee, O Lord.

¶ *Then shall the Minister say,*

[A.D. 1549.]
Rev. iv. 8.
Prov. xviii. 10.
Isa. xxvii. 4.
Matt. xxviii. 18.

THE Almighty Lord, who is a most strong tower to all them that put their trust in him, to whom all things in heaven, in earth, and under the earth, do bow and obey, be

dolorum : et non habentem fiduciam nisi in tua misericordia, ad sacramentum reconciliationis admitte. Per Christum Dominum nostrum.

¶ *Deinde dicatur Psalmus.*

IN te, Domine, speravi . . . non confundar in æternum. Salisbury Use.
De extrema Unctione.

¶ *Finito psalmo cum.*

Gloria Patri, et Filio : et Spiritui Sancto.
Sicut erat in principio, et nunc, et semper : et in sæcula sæculorum.
Amen.

Tota dicatur Antiph.

SALVATOR mundi, salva nos, qui per crucem et sanguinem redemisti nos : auxiliare nobis te deprecamur, Deus noster.

VIRTUTUM cœlestium Deus, [Greg. Ad Visitandum Infirmum.]
qui ab humanis corporibus omnem languorem et omnem infirmitatem præcepti tui potestate depellis, adeste propitius huic famulo tuo *III.*

quenched, the love to God cooled; God would be pleased to renew these, to strengthen faith, to soften the heart, to give life to devotion, warmth to love. Then follows a petition for external continuance in the Communion of the Saints, that though from circumstances the sick man is unable publicly to associate with God's people in the outward ordinances of religion, he may still be united in heart to Christ's mystical Body.

The prayer then asks that God will accept his contrition, will mitigate his pain, will grant him remission of all his sins, and finally will give him eternal salvation; and all for the merits of Jesus Christ his Lord.

THE PSALM.

This Psalm holds a place in the services for the Visitation of the Sick in both the Western and Eastern Churches. In the Sarum Manual it is given at full length: in our Prayer Book the last five verses have been omitted, since they speak of the sick man as already delivered and restored to health, and are therefore not so suitable to the case of one still in affliction.

The Psalm is most appropriate for the position it holds; throughout it runs a mingled strain of fervent petition and earnest profession of firm faith in the promises and love of God. It opens with prayer for deliverance, protection, and help; and grounds these petitions on the Psalmist's constant resort to God in time of trouble as his castle and house of defence. Then follows a memorial of God's past dealings, how even from the hour of birth upward He has been the stay and strength of His

servant; then, again, fresh prayer that God, Who has so long shown His goodness, will not now desert and leave His follower, when His help is specially needed and doubly required.

Above all, the Psalm points to the great Example offered to His suffering servants by the greatest of all sufferers; for it is of Him chiefly that it speaks; and in His "patient abiding always" may the servant see the meekness and submission of his Master as a pattern which he himself is humbly to copy in the time of affliction. This application of the Psalm is indicated by the Antiphon which follows the Doxology.

THE ANTIPHON.

This Antiphon is extremely interesting as being the only one retained in the Book of Common Prayer; and as still showing the manner in which Antiphons were formerly appended to Psalms for the purpose of drawing out their spiritual meaning or giving them the turn required for the special occasion on which they were used. In this case it clearly points to the preceding Psalm as spoken in the Person of Christ, our suffering Saviour; and pleads the sufferings there expressed as the cause of that human sympathy which is still and ever felt for His members by the Divine Redeemer. [See also p. 59, note.]

THE BENEDICTIONS.

The first of these benedictory forms was inserted as the conclusion of the Visitation Office in 1549, and bears some resemblance to a Collect in the Sacramentary of St. Gregory, which

Phil. ii. 9, 10.
Ps. xx. 1, 2.
Acts iv. 10, 12.
xiii. 28.
Isa. xlv. 21
22. 17.
1 Cor. iii. 11.

now and evermore thy defence, and make thee know and feel, that there is none other name under heaven given to man, in whom, and through whom, thou mayest receive health and salvation, but only the Name of our Lord Jesus Christ. Amen.

¶ *And after that shall say,*

Ps. lxxvi. 15.
Acts xx. 32.
1 Pet. iv. 19.
Ps. iv. 6.
Isa. xxvi. 3.
Numb. vi. 24—26.

UNTO God's gracious mercy and protection we commit thee. The Lord bless thee and keep thee. The Lord make his face to shine upon thee, and be gracious unto thee. The Lord lift up his countenance upon thee, and give thee peace, both now and evermore. Amen¹.

A Prayer for a sick child.

2 Sam. xii. 16, 22.
Ps. lxxviii. 20.
Mark v. 22—24.
35—42.
Ps. cvi. 4.
Job vii. 1.
Ps. vi. 2, 4.
Phil. ii. 27.
2 Cor. v. 15.
Ps. lxxi. 18.
John xiv. 2, 3.
Luke xvi. 9.
Ps. xvi. 11.
Ps. xlv. 26.
Rev. xiv. 13.
xix. 6.

O ALMIGHTY God and merciful Father, to whom alone belong the issues of life and death; Look down from heaven, we humbly beseech thee, with the eyes of mercy upon this child now lying upon the bed of sickness: Visit *him*, O Lord, with thy salvation; deliver *him* in thy good appointed time from *his* bodily pain, and save *his* soul for thy mercies' sake. That if it shall be thy pleasure to prolong *his* days here on earth, *he* may live to thee, and be an instrument of thy glory, by serving thee faithfully, and doing good in *his* generation; or else receive *him* into those heavenly habitations, where the souls of them that sleep in the Lord Jesus enjoy per-

ut, fugatis infirmitatibus et viribus receptis, nomen sanctum tuum instaurata protinus sanitate benedicat. Per Dominum.]

BENEDICAT vos Dominus et cunctodiat semper. Ostendat Dominus faciem suam super vos et miseretur vestri. Convertat Dominus vultum suum ad vos, et det vobis pacem. Per Dominum.

Miss. Gallic. Grimold. Sacram. Benedict. quotid. diebus dicend.

petual rest and felicity. Grant this, O Lord, for thy mercies' sake, in the same thy Son our Lord Jesus Christ, who liveth and reigneth with thee and the Holy Ghost, ever one God, world without end. Amen.

A Prayer for a sick person, when there appeareth small hope of recovery.

O FATHER of mercies, and God of all comfort, our only help in time of need; We fly unto thee for succour in behalf of this thy servant, here lying under thy hand in great weakness of body. Look graciously upon *him*, O Lord; and the more the outward man decayeth, strengthen *him*, we beseech thee, so much the more continually with thy grace and holy Spirit in the inner man. Give *him*

2 Cor. i. 3, 4.
Ps. xlvii. 1.
Heb. iv. 16.
Matt. xi. 28.
James v. 13—15.
Ps. cxix. 132.
xli. 3.
2 Cor. iv. 16.
Eph. iii. 14, 16.
Acts v. 31.
2 Cor. vii. 10, 11.
Ps. li. 1.
Eph. i. 13, 14.
Ps. xxxix. 15.
Luke i. 37.
2 Kings xx. 56.
2 Tim. iv. 6—8.
Isa. xxxviii. 1.
Luke xii. 35—37.
40.
Isa. lvii. 2.

was used for the Visitation of the Sick. The other, the ancient Jewish Benediction, first appears in Bishop Cosin's handwriting, at the end of the Office in his Durham book. Mr. Palmer

¹ The following is the Office for anointing which was inserted here in 1549, but omitted in 1552:—

¶ If the sick person desire to be anointed, then shall the Priest anoint him upon the forehead or breast only, making the sign of the cross, saying thus,

AS with this visible oil thy body outwardly is anointed: so our heavenly Father, Almighty God, grant of His infinite goodness, that thy soul inwardly may be anointed with the Holy Ghost, who is the Spirit of all strength, comfort, relief, and gladness: and vouchsafe for His great mercy (if it be His blessed will) to restore unto thee thy bodily health, and strength, to serve Him; and send thee release of all thy pains, troubles, and diseases, both in body and mind. And howsoever His goodness (by His divine and unsearchable providence) shall dispose of thee: we, His unworthy ministers and servants, humbly beseech the Eternal Majesty to do with thee according to the multitude of His innumerable mercies, and to pardon thee all thy sins and offences, committed by all thy bodily senses, passions, and carnal affections: who also vouchsafe mercifully to grant unto thee ghostly strength, by His Holy Spirit, to withstand and overcome all temptations and assaults of thine adversary, that in no wise he prevail against thee, but that thou mayest have perfect victory and triumph against the devil, sin, and death, through Christ our Lord: Who by His death hath overcome the prince of death, and with the Father and the Holy Ghost evermore liveth and reigneth God, world without end. Amen.

Usque quo, Domine? Psalm xiii.

found it used as a Benediction in an ancient Irish Manual or *Rituale*, published by Sir William Betham, in the first number of his Antiquarian Researches, from a MS. which he refers to the seventh century. It is also extant in ancient Gallican and Anglo-Saxon Missals, as in that of Grimoldus printed by Pamelius. [Liturgicon ii: 509.]

THE SPECIAL PRAYERS.

The four prayers appended to the Visitation Office were added in 1661. The first of them, for a sick child, seems intended as a provision for those whom extreme youth or infancy would incapacitate from taking part in the actual Visitation Office; and to whom also the greater part of it would be inapplicable. The second Prayer is for a sick man when there appears small hope of recovery. Its chief intent is to pray God to vouchsafe spiritual consolations in Christ Jesus, to give the man unfeigned repentance for the errors of his life past; if it seems fit in His eyes, to raise him up again; if not to receive his soul into the everlasting kingdom of Heaven. The third is a commendatory prayer. In the Sarum Manual there is given a Service, "Commendatio Animarum," but it contains no prayer from which this could have been derived. A hint seems to have been taken for a portion of it from the Litany in the service of Extreme Unction: "Ut quic-

Matt. xxv. 34.
2 Pet. i. 10, 11.

unfeigned repentance for all the errors of *his* life past, and stedfast faith in thy Son Jesus, that *his* sins may be done away by thy mercy, and *his* pardon sealed in heaven, before *he* go hence, and be no more seen. We know, O Lord, that there is no word impossible with thee; and that, if thou wilt, thou canst even yet raise *him* up, and grant *him* a longer continuance amongst us. Yet, forasmuch as in all appearance the time of *his* dissolution draweth near, so fit and prepare *him* we beseech thee, against the hour of death, that after *his* departure hence in peace, and in thy favour, *his* soul may be received into thine everlasting kingdom, through the merits and mediation of Jesus Christ, thine only Son, our Lord and Saviour. *Amen.*

A commendatory Prayer for a sick person at the point of departure.

Mark xii. 26, 27.
Heb. xii. 22, 28.
2 Cor. v. 4, 6, 8.
Acts vii. 59.
1 Pet. iv. 19.
1 John iv. 14.
Ps. xxvi. 9, 11.
cxvi. 15.
Rev. i. 5, 6.
vii. 14.
Eccl. vii. 20.
1 John v. 19.
Eph. vi. 11.
Gal. v. 17.
Eph. v. 25, 27.
Eccl. vii. 2.
Job xiv. 10, 11.
Ps. xxxix. 4, 5.
xc. 12.
Deut. xxxii. 46,
47.
Rom. v. 21, vi. 23.

O ALMIGHTY God, with whom do live the spirits of just men made perfect, after they are delivered from their earthly prisons; We humbly commend the soul of this thy servant, our dear *brother*, into thy hands, as into the hands of a faithful Creator, and most merciful Saviour; most humbly beseeching thee, that it may be precious in thy sight. Wash it, we pray thee, in the blood of that immaculate Lamb that was slain to take away the sins of the world; that whatsoever defilements it may have contracted in the midst of this miserable and naughty world, through the lusts of the flesh, or the wiles of Satan, being purged and done away, it may be presented pure and without spot before thee. And teach us who sur-

vive, in this and other like daily spectacles of mortality, to see how frail and uncertain our own condition is, and so to number our days, that we may seriously apply our hearts to that holy and heavenly wisdom, whilst we live here, which may in the end bring us to life everlasting, through the merits of Jesus Christ thine only Son our Lord. *Amen.*

A Prayer for persons troubled in mind or in conscience.

O BLESSED Lord, the Father of mercies, and the God of all comforts, We beseech thee, look down in pity and compassion upon this thy afflicted servant. Thou writest bitter things against *him*, and makest *him* to possess *his* former iniquities; thy wrath lieth hard upon *him*, and *his* soul is full of trouble: But, O merciful God, who hast written thy holy word for our learning, that we, through patience and comfort of thy holy Scriptures, might have hope; give *him* a right understanding of *himself*, and of thy threats and promises, that *he* may neither cast away *his* confidence in thee, nor place it any where but in thee. Give *him* strength against all *his* temptations, and heal all *his* distempers. Break not the bruised reed, nor quench the smoking flax. Shut not up thy tender mercies in displeasure; but make *him* to hear of joy and gladness, that the bones which thou hast broken may rejoice. Deliver *him* from fear of the enemy, and lift up the light of thy countenance upon *him*, and give *him* peace, through the merits and mediation of Jesus Christ our Lord. *Amen.*

2 Cor. i. 3.
Ps. ciii. 13.
Isa. lxiii. 15, 16.
Job xiii. 26.
1 Kings xvii. 13.
Ps. lxxxviii. 3-7.
James v. 11.
Rom. xv. 4.
Eph. i. 15.
1 John iii. 20, 21.
1 Cor. xi. 31.
Heb. x. 35, 36.
Jer. xvii. 7, 4.
2 Cor. xii. 9.
Matt. xii. 20.
Ps. lxxvii. 9, 11, 8.
Ps. lxxvii. 1.
Ps. xci. 1, iv. 6.
Num. vi. 26.
Phil. iv. 7.

quid vitiorum fallente diabolo et propria iniquitate atque fragilitate contraxit clementer indulgere digneris. Te rogamus, audis nos." The application to the survivors seems to be quite peculiar to our Prayer Book.

The fourth is a prayer for those troubled in conscience. Its chief aim is to pray to God to enable the man rightly to know and judge himself, that he may not on the one hand be unduly cast down, or on the other too self-confident; that he may fully understand the threatenings and promises in God's word, that so he may not be driven into despair, or tempted to presume falsely on the mercy of the Almighty. Finally, that God would deliver him and give him peace through the merits and mediation of Christ.

In Bishop Cosin's Durham Prayer Book the following Rubric was inserted by him at the end of the Visitation Office.

"If any sick persons desire the prayers of the Church in

publick, they are to send their names in writing to the Curate, who immediately after the final Collect of Morning or Evening Prayer shall declare the same, and use the form above prescribed, beginning at the words, *O Lord, save Thy servant, &c.*, unto the *Exhortation*, and ending with these two last prayers, *The Almighty Lord, &c. Unto God's gracious protection, &c.*"

This rubric was erased by the Committee of Revision, probably on account of that which was connected with the Prayer for all conditions of men. But that the custom had been adopted is evident from the ninth of Bishop Wren's Injunctions, which orders that "when any need is, the sick by name be prayed for in the reading-desk, and nowhere else, at the close of the first service; except it be in the afternoon, and then to be done immediately after the Creed, using only these two Collects, which be set down in the Service Book for the Visitation of the Sick." [Cardw. Docum. Ann. ii. 203.] See also Granville's Remains, ii. 42, 103.

THE COMMUNION OF THE SICK.

¶ Forasmuch as all mortal men be subject to many sudden perils, diseases, and sicknesses, and ever uncertain what time they shall depart out of this life; therefore, to the intent they may be always in a readiness to die, whensoever it shall please Almighty God to call them, the Curates shall diligently from time to time (but especially in the time of pestilence, or other infectious sickness) exhort their Parishioners to the often receiving of the holy Communion of the body and blood of our Saviour Christ, when it shall be publicly administered in the Church; that so doing, they may, in case of sudden visitation, have the less cause to be disquieted for lack of the same. But if the sick person be not able to come to the Church, and yet is desirous to receive the Communion in his house; then he must give timely notice to the Curate, signifying also how many there are to communicate with

him (which shall be three, or two at the least), and having a convenient place in the sick man's house, with all things necessary so prepared, that the Curate may reverently minister, he shall there celebrate the holy Communion, beginning with the Collect, Epistle, and Gospel, here following.

The Collect.

ALMIGHTY, everliving God, maker of mankind; who dost correct those whom thou dost love, and chastise every one whom thou dost receive; We beseech thee to have mercy upon this thy servant visited with thine hand, and to grant that he may take his sickness patiently, and recover his bodily health, (if it be thy

Deut. xxxii. 39,
40.
Isa. lxi. 8, 9.
Job v. 17, 18.
Heb. xii. 5, 6.
Ps. lxxxvi. 15, 16,
xxxix. 10, 11, 13.
Isa. xxxviii. 2-5.
James i. 2-4.
Luke xxii. 42.
xxiii. 46.
Eph. v. 25-27.
Jude 24, 25.

It has been a universal practice in the Catholic Church to administer the Holy Communion to the sick, and especially to the dying. We have evidence of this in the writings of the Fathers, in Canons, and other ancient documents. In the Eastern Church it was called *εφθδιον*, in the Western *viaticum*, both words meaning provision, as it were, laid up to sustain the recipients in their journey to the other world. In the earlier documents of the English Church we find great stress laid upon the reception of the Eucharist by the Sick: as the following examples show. Archbishop Theodore (Penitential, cap. 41), after speaking of the penance imposed before reconciliation of penitents adds,—"Si vero periculum mortis, propter aliquam infirmitatem, incurrerint, ante constitutum tempus reconciliari eos oportet, ne forte, quod abest, sine communione ab hoc sæculo discedant." And again, in the 4th sect. of the same chapter, the like indulgence is to be granted even to those who had not previously begun a course of repentance. "Si quis non poenitet, et forsitan ceciderit in ægritudine, et quæsierit communicare, non prohibeatur, sed date ei sanctam communionem, ita tamen ut omnia sit ante confessus: et mandate illi ut si placuerit Dei misericordiae ut evaserit de ipsa ægritudine, mores suos et actus in quibus antea deliquit, omnino corrigere debeat, cum poenitentia."

The Excerpts of Archbishop Egbert exhibit a similar case, —they direct "Ut cuncti sacerdotes . . . omnibus infirmis ante exitum vitæ viaticum et communionem corporis Christi misericorditer tribuant," while in the 22nd of the said excerpts it is further ordered, "Ut presbyter eucharistiam habeat semper paratam ad infirmos, ne sine communione moriantur."

So far was this feeling carried, that it was even directed that Priests should carry about with them the consecrated Eucharist, to administer it upon sudden occasions. This custom, however, seems never to have prevailed to any extent in the English Church. King Edgar's 65th Canon [A.D. 960] orders every priest "to give housel to the sick, when they need it;" and the Canons of

Ælfric direct "the priest shall housel the sick and infirm, while the sick can swallow the housel; and he shall not administer it, if he be half living, because Christ commanded that the housel should be eaten."

A Canon of the Synod of Westminster (A.D. 1188) goes also indirectly to prove the constant care which was taken in the early English Church that all sick persons might receive the Holy Communion. "2. Sancimus etiam, ut ultra octo dies corpus Christi non reservetur; neque ad infirmos, nisi per sacerdotum, aut per diaconum, aut necessitate instante, per quemlibet cum summa reverentia deferatur." [Mask. Mon. Rit. I. cccxiii.]

The reservation of the Holy Sacrament for the purpose of administration to the sick was probably a primitive practice; for it is named at a very early period. Justin Martyr, in his Apology, tells us that those who were absent from the public celebration had the elements brought to them at their own houses, and this seems to have been part of the duty of the deacons or that day—καλούμενοι παρ' ἡμῶν Διάκονοι δεδῶσιν ἐκάστῳ τῶν παρόντων, μεταβαλεῖν ἀπὸ τοῦ εὐχαρισθέντος, ἕρτου καὶ οἴνου καὶ ὕδατος, καὶ τοῖς οὐ παρούσι ἀποφέρουσι.

There is ample evidence in the History of the Church to show that this was the common mode of proceeding; and the practice of reservation was provided for in the first Rubric of the Office for the Communion of the Sick in the Prayer Book of 1549,— "If the same day there be a celebration of the Holy Communion in the church, then shall the Priest reserve (at the open Communion) so much of the Sacrament of the Body and Blood as shall serve the sick person, and so many as shall communicate with him (if there be any), and so soon as he conveniently may, after the open Communion ended in the church, shall go and minister the same, first to those that are appointed to communicate with the sick (if there be any) and last of all to the sick person himself. But before the Curate distribute the Holy

gracious will,) and whensoever *his* soul shall depart from the body, it may be without spot presented unto thee, through Jesus Christ our Lord. *Amen.*

The Epistle.

Heb. xii. 5.

MY son, despise not thou the chastening of the Lord, nor faint, when thou art rebuked of him. For whom the Lord loveth he chasteneth;

and scourgeth every son whom he receiveth.

The Gospel.

VERILY, verily, I say unto you, *John v. 24.* He that heareth my word, and believeth on him that sent me, hath everlasting life, and shall not come into condemnation; but is passed from death unto life.

¶ *After which, the Priest shall proceed according to the form before prescribed for the holy Communion, beginning at these words [Ye that do truly, &c.]*

¶ *At the time of the distribution of the holy Sacrament, the Priest shall first receive the Communion himself, and after minister unto*

Communion, the appointed *general confession* must be made in the name of the communicants, the Curate adding the *Absolution with the comfortable words of Scripture* following in the open Communion; and after the Communion ended, the Collect, *Almighty and everliving God, we most heartily thank thee, &c.* But if the day be not appointed for the open Communion in the church, then (upon convenient warning given) the Curate shall come and visit the sick person afore noon. And having a convenient place," &c.

The same practice was also provided for in another way by the second Rubric at the end of the same Office,—“And if there be more sick persons to be visited the same day that the Curate doth celebrate in any sick man’s house; then shall the Curate (there) reserve so much of the Sacrament of the Body and Blood as shall serve the other sick persons, and such as be appointed to communicate with them (if there be any), and shall immediately carry it and minister it unto them.”

It will thus be seen that the original form of our Office provided for reservation in ordinary cases, and for private celebration in exceptional ones. In 1552 both the above Rubrics were dropped, and private celebration alone provided for, the present Collect, Epistle, and Gospel being then appointed. The Rubric respecting reservation reappears, however, eight years later, in the Latin Prayer Book of Queen Elizabeth’s Reign; from which fact it may be reasonably concluded that the practice did not cease when the rubric dropped out of the English Book in 1552. The same conclusion may be drawn from the continuance of the practice in the Scottish Church, and by the Nonjurors. In a work¹ on “the Declaration on Kneeling,” by the Rev. T. W. Perry, the author states that he knew [A.D. 1863] “that a member of the present English Episcopate (and one who would certainly not be said to hold very high views on the Eucharist) not unfrequently, in his ministrations as a parochial Incumbent, reserved the Sacrament, at the public celebration, for the use of the sick.” The same writer also says that the present Archbishop of Canterbury, when Bishop of Ripon, was appealed to on the subject of reservation during the cholera in Leeds, and that “while saying that he could not *authorize* reservation, he did not feel himself justified in forbidding it in that emergency¹.” The fact is, that in this, as in many other particulars, the temporary dangers and errors which led the Reformers to discourage ancient usages have long passed away; and practical men feel that a return to them is often expedient, both for the promotion of God’s glory, and for the good of souls.

The modern practice is, however, justified on ancient authority

by Mr. Palmer in his *Origines Liturgicæ*, where he adduces the following instances of ancient private celebration (*Orig. Liturg. ii 232*),—

“Paulinus, Bishop of Nola, caused the Eucharist to be celebrated in his own chamber not many hours before his death. ‘Cum ante triduum, quam de hoc mundo ad cœleste habitaculum vocaretur, cum jam de salute ejus omnes desperassent, et duo ad eum episcopi visitandi studio convenissent, id est, S. Symachus et Benedictus Hyacinthinus . . . quasi profecturus ad Dominum, jubet sibi ante lectulum suum sacra mysteria exhiberi, scilicet ut una cum sanctis episcopis oblato sacrificio animam suam Domino commendaret. Vita Paulini Nolani auctore Uranio Presb. apud Surium Junii 22. p. 733.’ Gregory Nazianzen informs us, that his father communicated in his own chamber, and that his sister had an altar at home [Gregor. Nazien. Orat. 19, de Laude Patris; Orat. 11, de Gorgonia]. St. Ambrose is also said to have administered the Sacrament in a private house in Rome. Per idem tempus cum trans Tiberium apud quendam clarissimum invitatus, sacrificium in domo offerret, &c. [Vita Ambrosii a Paulino, p. iii. Append. tom. ii. Oper. Ambros. edit. Benedict.]”

At the same time that the private celebration has been adopted more freely than in ancient times, restriction has been laid upon a too free use of it by Canon 71, which enjoins that “No minister shall preach or administer the Holy Communion, in any private house, except it be in times of necessity, when any being either so impotent as he cannot go to the church, or very dangerously sick, are desirous to be partakers of the holy Sacrament, upon pain of suspension for the first offence, and excommunication for the second,” while the rubric directs, “if the sick person be not able to come to the church, and yet is desirous to receive the Communion in his house; then he must give timely notice, &c.” Thus considerable limitation is indicated with respect to private celebrations of the Holy Communion; and it is very desirable that this limitation should be practically acted upon in the spirit of the Canon, as the celebration of the Holy Communion in a room used for ordinary living, and on a table used for meals or other domestic purposes is a practice which it is difficult to guard from irreverence and from dishonour towards so holy a Sacrament.

To guard against it as much as possible, care should be used to carry out the spirit of the Rubric, by having “a convenient place” and “all things necessary” for ministering the Communion. The proper vestments should be worn by the Priest: proper vessels should be provided for the celebration; and fine linen cloths should also be taken by him to be used as at the altar in the church:

¶ *At the time of the distribution, &c.]* The object of this

¹ Historical Considerations relating to the Declaration on Kneeling, &c., by the Rev. T. W. Perry, 1863, p. 139.

them that are appointed to communicate with the sick, and last of all to the sick person.

¶ But if a man, either by reason of extremity of sickness, or for want of warning in due time to the Curate, or for lack of company to receive with him, or by any other just impediment, do not receive the Sacrament of Christ's body and blood, the Curate shall instruct him, that if he do truly repent him of his sins, and stedfastly believe that Jesus Christ hath suffered death upon the cross for him, and shed his blood for his redemption, earnestly remembering the benefits he hath thereby, and giving him hearty thanks therefore, he doth eat and drink the body and blood of our Saviour Christ profitably to his soul's health, although he do not receive the Sacrament with his mouth.

¶ When the sick person is visited, and receiveth the holy Communion all at one time, then the Priest, for more expedition, shall cut off the form of the Visitation at the Psalm [In thee, O Lord, have I put my trust] and go straight to the Communion.

¶ Deinde communicetur infirmus nisi prius communicatus fuerit: et nisi de vomitu vel alia irreverentia probabiliter timeatur: in quo casu dicat sacerdos infirmo. Salisbury Use.
[Man. de Extrem.
Unct.]

Frater, in hoc casu sufficit tibi vera fides, et bona voluntas: tantum crede, et manducasti.

Rubric was probably to avoid any danger from contagion to those who partook with the sick man; in addition to this there are many cases where it would be felt there were reasons which made it undesirable for the fellow-communicants to receive after the sick person. Care should be taken not to consecrate more of the elements than is absolutely necessary, so that none may remain over after the sick man has communicated. If any remain, and circumstances prevent its being partaken of by the sick man or the Priest, it may be consumed in the fire. "Sed hoc quod reliquum est de carnibus et panibus in igne incendi præcepit. Quod nunc vidimus etiam sensibilibus in ecclesia fieri, ignique tradi quæcunque remanere contigerit inconsumpta." [Hesych. in Leo. lib. ii.]

¶ But if a man, either by reason, &c.] This Rubric sets forth certain cases in which, though a man may be prevented from actually receiving the Sacrament of Christ's Body and Blood, he may yet spiritually be a partaker. Extremity of sickness, want of warning to the Curate, lack of company, or any other just impediment are all alleged as reasons which may make actual Communion impossible. Ignorance, want of due understanding of the Sacrament, carelessness about receiving it, cannot be just impediments; the man must be fitted and willing to receive the Holy Sacrament, if he is to be able spiritually to partake.

In the York Manual a direction is given as to those who are not to receive the Holy Communion,—

"Dum vomet infirmus, non debet sumere corpus, Christi nisi credit; credendo fideliter egit; Ebrius, insanus, erroneus, et male credens, Et pueri, corpus Christi non suscipiant hi; Non nisi mense semel, aliquis communicet æger."

In the Sarum Manual provision is made for Spiritual Communion in cases where actual reception of the elements is impossible. The subject is touched on in a very reverential spirit in the Penitential of Egbert, Archbishop of York, a work dating from the eighth century.—"Si homini alicui eucharistia denegata sit, et ipse interea moriatur, de his rebus nihil aliud conijcere possumus, nisi quod ad iudicium Dei pertineat, quoniam in Dei potestate erat, quod absque eucharistia obierit."

The Curate, in a case where the sick man is prevented from communicating, is to instruct him that "if he truly repent him of his sins, and stedfastly believe that Jesus Christ hath suffered

death upon the cross for him, and shed His blood for his redemption, earnestly remembering the benefits he hath thereby, and giving Him hearty thanks therefore, he doth eat and drink the body and blood of our Saviour Christ profitably to his soul's health, although he do not receive the Sacrament with his mouth."

The Priest should instruct the sick man to call to mind all that Christ did and suffered for his sake; how He left the glory that He had from all eternity with the Father, to take upon Him the form of a servant; how He humbled Himself and became of no reputation for our sakes; how He endured the contradiction of sinners; how He had not a place where to lay His head; how for us He died and for us rose again and ascended into heaven, where He ever liveth to make intercession for His people. He should bid the sufferer meditate on the infinite love of the Redeemer, as set forth in a life during which He went about doing good, as exemplified in a death of suffering most intense, of humiliation most abject. He should bid him see in Jesus, the Way, the Truth, and the Life, should urge him to look to that Saviour, not simply as his Teacher, but as the source of his spiritual life. Specially should the Priest direct the sick man's thoughts to the full, perfect, and sufficient sacrifice, oblation, and satisfaction for the sins of the whole world once offered by Christ on the cross for our redemption. He should lead him to plead that all-sufficient sacrifice with God the Father, to trust to it for the forgiveness of all his sins, to believe that through it he may receive strength to stand against the wiles and snares of the devil; that through it he may receive the grace, the blessing, he needs. He should lead him to see in this sacrifice his hope for a peaceful death, his expectation of a glorious resurrection. The sick man should be taught to present himself, his soul and body, to be a reasonable, holy, and lively sacrifice unto God, beseeching the Lord that neither in will nor deed he may ever again depart from His ways. He should be reminded that he has to do with One who sees the sincere desire of his heart, and who accepts the earnest wish and longing where the power actually to Communicate is wanting. Thus instructed, the sick man may receive in his soul the comforts and strength to be derived from the blessed Communion of his Saviour's body and blood, though from some just impediment he is prevented from actually eating that Bread and drinking that Cup. And, if possible, his intentions should be directed towards the Holy Sacrament at the very time of its celebration in church.

¶ *In the time of the plague, sweat, or such other like contagious times of sickness or diseases, when none of the Parish or neighbours can be gotten to communicate with the sick in their houses, for fear of the infection, upon special request of the diseased, the Minister may only communicate with him.*

In the time of the plague] This rubric shows that in certain cases it is plainly the duty of a Parish Priest to visit persons suffering from infectious diseases. It is evident from the parenthesis in the 67th Canon, which directs the minister to resort to the sick person "(if the disease be not known, or probably suspected to be infectious)," that some discretion is allowed in visiting such cases.

There are circumstances in which nothing should prevent a parish priest visiting even where the risk of infection is strongest. If he be called upon to baptize a dying child, or be sent for by a sick person, or by some friend who has a right to speak on his behalf, no clergyman should for a moment think of refusing to incur any danger; especially if the infected person express a hearty desire for the Holy Communion, the Minister must go without any hesitation or attempt to excuse himself. He is going about his Master's business, and should go in humble trust that that Master will be with him and protect him in his work. Where it may be perfectly allowable for others to shrink and hold back, as in the case of the diseases mentioned in the rubric, and in sicknesses of similar malignity, a clergyman has no right to hesitate. His duty is clear, to be ready to comfort and help those who need his spiritual advice and counsel. Still, while a clergyman goes to such cases trusting to the watchful care of his Master, he should not omit any proper precautions that he can take, for his own sake, for that of his family, and for that of other sick persons he may have to visit.

The following rules for avoiding infection are taken from the "Directorium Pastorale," second edition, p. 221.

Some Rules for avoiding Infection.

1. Avoid visiting dangerous cases of illness with the stomach in a very empty condition, or with the lungs exhausted by running or quick ascent of stairs. Calmness is a great safeguard. It is better to take a biscuit and glass of wine before starting to visit very extreme cases of infectious disease.
2. Do not place yourself between the patient and the fire, where the air is drawn from the former to the latter over your person.
3. Do not inhale the breath of the patient.
4. Do not keep your hand in contact with the hand of the sufferer.
5. Avoid entering your own or any other house until you have ventilated your clothes and person by a short walk in the open air. You are morally bound to take this precaution in respect to other sick persons whom you have to visit; and, in the case of your own family, although they must abide by the risks which belong to your calling, they have a claim upon you for the use of all lawful precautions in making that risk as small as possible.

6. In times when you are much among infectious cases, use extra care to keep the perspiratory ducts of the skin clear of obstruction, that the excretive force of the perspiration may have fair play in throwing off infectious matters floating in the air.

By taking such precautions as these, clergymen may visit infectious cases with at least as much security as medical men.

[The ancient English form of exhortation given in the note on the "Profession of Faith," a few pages back, appears to belong to a type commonly used in the Middle Ages. Mr. Maskell's form is taken from a MS. in St. John's College Library, Oxford; the following is from a MS. in the Bodleian [Rawlinson, c. 587, ff. 53, 54.] In the same collection [Rawlinson, c. 108. 90] there is a Latin form apparently drawn up for the use of priests in the diocese of Laudun, in the fifteenth century, which begins in a similar manner.

"Antequam communicetur infirmus et ante unccionem :—

"Brother, be ye gladde y^t ye shall dye in Chrysten beleve? Re. Ye, syr.

"Knowe ye well y^t ye have not so well lyved as ye shulde? Ye, syr.

"Haue ye wille to amende yow if ye had space to lyve? Ye, syr.

"Beleve ye that o^r Lorde Christ Jhu goddys soon of heaven was born of the blessyd vyrgyne our ladie saynt Mary? Ye, syr.

"Beleve ye that our Lorde Christ Jhu dyed vpon the crosse to bye mans sowle upō the good ffrydaie? Ye, syr.

"Thancke ye him entierly therof? Ye, syr.

"Beleve ye y^t ye may not be saved but by his precious death? Ye, syr.

"Tunc dicat sacerdos.

"Therfor, Brother, while yo^r sowle is in yo^r bodye, thancke ye god of his death, and haue ye hole truste, to be saved, through his precyouse death, and thyncke ye on non other worldely goode, but onely in Christe Jhus deathe, and on his pytefull passyon, and saye after me, My swete Lorde Christ Jhu, I put thy precyous passion betwene the and my evill werke and betwene me and thy wrathe.

"Et dicat infirmus ter.

"In manus tuas Domine, etc. *Vel sic* :—

"Lorde Christ Jhu, in to thy handes I betake my sowle and as thou boughtest me, bodye and soule I betake to the."

The beautiful words, "I put Thy precious passion," &c., are taken from St. Anselm; unless indeed the reverse be the case, and St. Anselm quoted them from a form familiar in his time.]

THE ORDER FOR
THE BURIAL OF THE DEAD.

Salisbury Use.
INHUMATIO DEFUNCTI.

¶ Here is to be noted, that the Office ensuing is not to be used for any that die unbaptized, or excommunicate, or have laid violent hands upon themselves.

THE BURIAL OFFICE.

A question not unfrequently arises, whether this Office must necessarily be used over all persons buried in consecrated ground, provided they do not belong to one of the three classes mentioned in the first rubric. There are (1) cases in which clergymen would rather avoid saying the Service over ill living and ill dying parishioners, and also (2) in which the survivors, being Dissenters, would prefer the omission of the Service, such omission being also in known agreement with the principles and wishes of the deceased. The only law of the Church on the subject, besides the rubric, is the following:—

“CANON 68.

“Ministers not to refuse to Christen or Bury.

“No Minister shall refuse or delay to christen any child according to the form of the Book of Common Prayer, that is brought to the Church to him upon Sundays or Holy Days to be christened, or to bury any corpse that is brought to the Church or Church-yard, convenient warning being given him thereof before, in such manner and form as is prescribed in the said Book of Common Prayer. And if he shall refuse to christen the one, or bury the other, (except the party deceased were denounced excommunicated *majori excommunicatione*, for some grievous and notorious crime, and no man able to testify of his repentance,) he shall be suspended by the Bishop of the diocese from his ministry by the space of three months.”

This Canon of 1603 thus imposes a penalty on the Clergyman for refusing to bury any person not excommunicated; does not impose it for delay unaccompanied by refusal; and says nothing about omission by mutual consent of the clergyman and the friends of the deceased. The rubric was added (at the suggestion of Bishop Cosin) in 1661. Bishop Gibson, in his Codex, evidently takes for granted that the service is to be said over all except those mentioned in the rubric, and his opinion is reproduced by Burn and later writers. But, until recent times, many persons were buried in private grounds, such as gardens, orchards, and fields; and probably a case had never arisen in which the omission of the Service was desired when the body of the deceased was brought to consecrated ground. Sir John Nicoll says [Kempe v. Wickes], “Our Church knows no such indecency as putting the body into the consecrated ground without the service being at the same time performed:” but this dictum must have been uttered in forgetfulness of the law of 1821, which directs that suicides (*felo de se*) shall be buried there without service, and which seems to be in accordance with the practice indicated by the first rubric, in which there is no prohibition of burial in consecrated ground.

An Act of Parliament [5 Geo. IV. c. 25] empowers the Irish clergy to omit the Service in certain cases other than those de-

finied by the rubric, and the preamble assumes that the clergy are bound to use it in every case which is not excepted by the statute or the rubric. The question seems never to have been fairly raised, and no judicial decision has defined the exact duty of a clergyman in respect to it. The nearest approach to such a definition is contained in an opinion given by Dr. Lushington on Sept. 7th, 1835, in which he says, “I think when the friends of the deceased apply to the clergyman to abstain from performing the funeral Service, on the ground that the deceased when alive was a dissenter, the clergyman may comply with such request¹.” In Lancashire, Roman Catholics have constantly been buried without any service in the Church or Churchyard; while, on the other hand, at the burial of Robert Owen the socialist, and of the infidel Carlile, the clergymen thought it their duty to say the Service, in the face of a strong protest against its use on the part of the relatives.

There are cases of notorious wickedness or infidelity, in which it might be the painful duty of the clergyman to refuse, on that account, to use the Office. In such cases it would not probably be difficult to obtain the assent of the survivors to such a course, if the reasons for taking it were solemnly told to them beforehand. Should it be impossible to obtain such an assent, there are few clergymen who would not be prepared to abide the consequences. But in the majority of cases, even where the life has been notoriously evil, there is still room for the charitable hope that the sinner has not been utterly forsaken by God’s mercy in his death.

not to be used for any that die unbaptized] Many infants and even adult persons die, of whom it is quite certain that they have not been baptized; and in such cases the law is clear. But it is an ancient rule of the Church that while conditional baptism should be administered to a living person, of whom it is uncertain whether or not he has been baptized previously, in the case of deceased persons, in a Christian country, their baptism is to be taken for granted unless there is proof to the contrary. The Archbishop of Canterbury has lately written, “that the Service of the Church of England for the burial of the dead is intended for those who have been made members of the Church of Christ by Baptism, and that to use that Service over the unbaptized would be an anomalous and irregular proceeding on the part of a minister of the Church of England².” A strict observance of the rubric tends very much to impress upon parents the necessity of Holy Baptism for their children.

or excommunicate] The rubric of 1661 is to be interpreted in accordance with the Canon of 1603: and hence a person “excommunicate” must mean one “denounced, excommunicated *majori excommunicatione*, for some grievous and notorious crime, and no

¹ British Magazine, viii. 569.

² Letter to a Unitarian preacher at Tenterden. May 20, 1865.

¶ *The Priest and Clerks meeting the Corpse at the entrance of the Church-yard, and going before it, either into the Church, or towards the Grave, shall say, or sing,*

man able to testify of his repentance." A formal absolution before death by the authority which has passed the sentence of excommunication is not, therefore, of absolute necessity to admit the use of the Office; an opening being left for the exercise of the charity of the Church towards even one excommunicated from its fold, if his repentance before death can be credibly shown to have taken place. While discipline is so little exercised as at present, there is seldom any occasion for taking this part of the rubric into consideration; but it is possible that a revival of discipline may take place, to the extent, at least, of excommunicating open and notorious evil livers, when it might sometimes become necessary to decide whether this charity of the Church could be exercised or not.

It is clear that *sentence* of excommunication is contemplated by the rubric, and that it does not include those who have deserved it, but upon whom it has not been actually pronounced¹, or *have laid violent hands upon themselves*] Suicides are divided by the common law of the land into two classes, those who have committed felony by a wilful murder of themselves, and those who have killed themselves while in a state of insanity. The first are held fully responsible for the consequences of their act; their property being forfeited to the Crown, and their bodies ordered to be buried in a churchyard or cemetery without any religious rite, and between the hours of nine and twelve at night. The second are considered to be in no degree responsible for their act, and the law does not impose any penal consequences upon it.

Such a distinction does not seem to be contemplated by the rubric, which speaks inclusively of all "who have laid violent hands upon themselves." Yet Christian charity requires that some distinction should be made, and such a distinction was implied, at least, by the ancient canons on the subject. Thus the council of Bracara, or Braga in Spain [A.D. 563], enjoins, "Concerning those who by *any fault* inflict death on themselves, let there be no commemoration of them in the Oblation . . . Let it be enjoined that those who kill themselves by sword, poison, precipice, or halter, or by any other means bring violent death upon themselves, shall not have a memorial made of them in the Oblation, nor shall their bodies be carried with Psalms to burial." This canon was adopted among the excerpts of Egbert, in A.D. 740, and is substantially repeated among some Penitential Canons of the Church of England in A.D. 963, and indicates the general principle of the canon law on the subject. This principle certainly indicates, that a distinction should be made between those who "by any fault" cause their own deaths, and those who do so when they are so far deprived of reason as not to be responsible in the sense of doing it by "any fault," wilfully and consciously. And the rubric being thus to be interpreted by a law of charity, the responsibility of deciding in what cases exceptions shall be made to its injunction is, by the nature of the case, thrown upon the clergyman who has cure of souls in the parish where the suicide is to be buried.

Numerous writers have laid it down that the verdict of the Coroner's jury relieves the clergyman from this responsibility, and that if that verdict is "Temporary Insanity" he is bound to disregard the fact that the deceased person has laid violent hands upon himself². But to adopt such a rule is to throw up

¹ Sentence of excommunication was very frequently pronounced in the 16th and 17th centuries; and there are entries in Parish Registers of those who have died and been buried as excommunicates. Lord George Gordon was excommunicated towards the end of the last century.

² It may be as well to state, that the "Coroner's Warrant" for the burial of a body over which an inquest has been called, is simply a discharge of the body from the custody of the Crown. In ordinary cases it is unconditional, and imposes no obligation of any kind as to interment. In a case of *felo de se* it orders burial in the manner stated above.

the discipline of the Church and to place it in the hands of a secular tribunal; one, moreover, which is apt to be influenced by secondary motives and feelings in this particular matter which are quite irrespective of the religious question. If the same jury were to be asked, quite independently of the question of forfeiture, whether the suicide was a person over whom they themselves could pronounce the words of the Burial Service, the reply would often be in the negative, and that the verdict of Temporary Insanity was one of charity towards the living rather than of justice towards the dead. There cannot be a doubt that many men would return such a verdict under the feeling that the self-murder was a great crime indeed, one for which the suicide deserved punishment if it had been possible to punish him, and one from which others ought to be deterred; but that not being able to punish him for his crime, they would not punish his family by adding to their sufferings. The question of the verdict is, therefore, legally and morally distinct from that of the rubric; and though the two are analogous, yet they must be judged by separate persons and by separate standards. The jury are the deputies of the State to decide whether or not the suicide was a felon by the laws of the State. The priest is the deputy of the Church, to decide whether the blessings of the Church can rightly be dispensed in the case of one who has taken away life contrary to the law of God.

In coming to this decision the verdict of the jury should have respectful attention, though it is not to be considered as an invariable law for the clergyman. It is not often, perhaps, that any circumstances within his own knowledge will compel him to act in a way that seems to be discordant with it; nor need he seek out information to disturb his mind on the subject. But if circumstances have come to his knowledge, which make it plain that there was no such insanity as to deprive the suicide of ordinary moral responsibility, then he is to remember (1) that he is a "steward of the mysteries of God," who has no right to misapply the blessings given him to dispense; and (2) that the scandal, and encouragement to suicide, which result from a too easy compliance, are in themselves great evils which it is his duty, as it is within his power, to prevent. In this case, as in the previous one of excommunication, a solemn explanation of the painful necessity might often win the sorrowful acquiescence of conscientious survivors.

either into the Church, or towards the Grave] This clearly authorizes the Priest to read the whole service at the Grave if, in his discretion, he should think it advisable to do so. In bad cases of infectious disease, it would be more proper that the body should not be taken into the Church; and there are many cases (with modern habits of delaying funerals for a week) in which it is not right to take it there when the Church is, or is about soon to be, occupied by a congregation.

shall say, or sing] The first of these beautiful processional Anthems is traceable to the ancient *Inhumatio Defuncti*, and was also a Compline Antiphon "in agenda Mortuorum" in the Antiphonarius of St. Gregory. The second was used in the *Vigilia Mortuorum* or Dirge of the Sarum rite. In Marbecke's Common Prayer Noted, they are arranged as Responses and Versicles, the divisions being made where the musical points stand, in the text above. The Response is also commenced again, with an "&c.," after the Versicle, from which it would appear that it should be repeated by the Choir. The second was thus arranged in the Primer of the fourteenth century.

R̄. I bileene that myn azenbiere lyueth and I am to rise of the erthe in the last day, and in my fleish I shal se God my Sauyour.

V̄. Whom I my self shal se and noon other: and myn ȳten ben to se.

R̄. And in my fleishe I shal se god my Sauyour.

John xi. 25, 26. I AM the resurrection and the life, saith the Lord : he that believeth in me, though he were dead, yet shall he live : And whosoever liveth and believeth in me shall never die.

Job xix. 25—27.
Cf. Chrys in 1 Thess. iv. 13. I KNOW that my Redeemer liveth, and that he shall stand at the latter day upon the earth. And though after my skin worms destroy this body, yet in my flesh shall I see God : whom I shall see for myself, and mine eyes shall behold, and not another.

1 Tim. vi. 7.
Job i. 21. WE brought nothing into this world, and it is certain we can carry nothing out : The Lord gave, and the Lord hath taken away ; blessed be the Name of the Lord.

¶ *After they are come into the Church, shall be read one or both of these Psalms following.*

[*Diri custodiam.* Psalm xxxix.
Domine, refugium. Psalm xc.]

¶ *Then shall follow the Lesson taken out of the fifteenth Chapter of the former Epistle of Saint Paul to the Corinthians.*

Printed at length in the Sealed Books.

A. EGO sum resurrectio et vita : qui credit in me, etiamsi mortuus fuerit, vivet : et omnis qui vivit et credit in me, non morietur in æternum.

Salisbury Use. Ant. to Benedictus, at the burial.

R. CREDO quod Redemptor meus vivit : et in novissimo die de terra surrecturus sum : Et in carne mea videbo Deum Salvatorem meum.

Salisbury Use. Vigils of the Dead.

¶ Quem visurus sum ego ipse et non alius : et oculi mei conspecturi sunt. Et in carne mea videbo Deum Salvatorem meum.

[*these Psalms following*] In the ancient Burial Office of the Church of England a number of psalms, 114. 25. 118. 42. 132. 139. 148, 149, 150, together with the seven penitential Psalms, or, instead of them [*“vel saltem Psalmum”*], the De Profundis, Psalm 130. It may be doubted whether all these psalms were used at every burial. In the Prayer Book of 1549, after the two prayers which followed the placing of the corpse in the grave, came this rubric, “¶ These Psalms, with other suffrages following, are to be said in the Church, either before or after the burial of the corpse :” the Psalms being 116: 139. 146. At the Holy Communion, Psalm 42, “Like as the hart desireth the water brooks,” was used as the Introit. Singular to say, no Psalms were printed in the Burial Service from 1552 to 1661, nor did the Introit appear in the Latin Office for the celebration of the Holy Communion at funerals. They appear to have been omitted in deference to the scruples of Bucer, who objected to prayers for the dead [Cosm v. 498]. At the last revision, in 1661, the Psalms 32 and 90 were inserted, and thus the Office regained its ancient and primitive character.

[*Then shall follow the Lesson*] This and other portions of the New Testament which are used in the Burial Service have been in use from the primitive ages of Christianity. In the Lectionary of St. Jerome¹ there are nine lections, “In Agenda Mortuorum,” and four of these are represented in the English Prayer Book, if we include the Epistle and Gospel which are directed by the Book of 1549 and the Latin Office of 1560. The following columns show how these portions of Scripture have been handed down to our Burial Office from the primitive Church :—

<i>St. Jerome's Lectionary.</i>	<i>Salisbury Use.</i>	<i>Book of Common Prayer.</i>
2 Macc. xii. 43.	Anniversary and Trental Epistle.	
1 Thess. iv. 13.	Funeral Epistle.	Funeral Epistle.

¹ For an account of the Comes Hieronymi, see page 70.

1 Cor. xv. 49.	Alternate Epistle.	Daily	Funeral Lesson.
Ezek. xxxvii. 1.	Alternate Epistle.	Daily	Funeral Anthem.
Rev. xiv. 13.			
John v. 21	Thursday, Gospel.	Funeral	Funeral Gospel [1560].
„ vi. 37.	Tuesday, Gospel.	Funeral	Funeral Gospel.
„ vi. 51.	Friday, Gospel.	Funeral	
„ xi. 24.	Sunday and Monday, Gospel.	Funeral	

There is no part of the New Testament which so comprehensively sets forth the doctrine that our Lord's Incarnation is the source of all spiritual life, and therefore the source of eternal life, as the chapter now read for the Lesson.

§ *The Holy Communion.*

If the Holy Communion is celebrated at a Funeral, the proper place for it is immediately after the Lesson, while the body of the deceased is yet in the Church.

In primitive times the departure of the soul and the burial of the body were ever associated with the Holy Eucharist : and the celebration of it at the burial of martyrs, and at their tombs on the anniversary day of their death, appears to have been the origin of saints' days². When Monica, the mother of St. Augustine, saw that her death was at hand in a strange country, Navigius, her other son, expressed a wish that she might die in her own land ; but her one care was that she might remain, body as well as soul, in the Communion of Saints. “Lay this body anywhere,” said she ; “let not the care for that any way disquiet

² Tertull. de Coron. iii. Ibid. de Monogam. x. Cypr. Ep. xxxiv. xxxvii. lvii. lxvi. Aug., Enchirid. cx. Posidonius, Vita S. Aug. xiii. Ambrose, de Obitu Valentin.

¶ *When they come to the Grave, while the Corpse is made ready to be laid into the earth, the Priest shall say, or the Priest and Clerks shall sing:*

you; this only I request, that you would remember me at the altar of the Lord, wherever you be." Afterwards St. Augustine writes, "And, behold, the corpse was carried to the burial: we went and returned without tears. For not even did I weep in those prayers which we poured forth unto Thee, when the Sacrifice of our Ransom was offered for her, as the manner is, while the corpse was by the side of the grave, previous to being laid therein¹."

That such was the custom of the Church may also be seen by the ancient Sacramentaries of the Primitive Church, in which there are Collects and Prefaces for the celebration of the Holy Communion, "In die depositionis defuncti" [Menard's Sac. Greg. 231], and from the Lectionary of St. Jerome, in which are Gospels and Epistles for the same occasion. In the Mediæval Church of England the same custom was observed, the burial of the dead being always either associated with the Holy Communion at the time or within a few days.

The Prayer Book of 1549 provided for a continuance of this primitive custom by placing at the end of the Burial Service an Introit, Collect, Epistle, and Gospel, arranged in the same order as those for Sundays and other Holy-Days, and headed "The Celebration of the Holy Communion when there is a Burial of the Dead." The Introit was that which was previously in use, the 42nd Psalm, "Like as the hart desireth the water brooks:" the Collect, that which is printed in the right-hand column beyond; and the Epistle and Gospel, those which have been noticed in the preceding note as coming down from the time of St. Jerome. When the Introits were removed from the Prayer Book, this one was removed among them, and the Gospel and Epistle ceased to be indicated in the English Prayer Book. Thus the Collect alone remained, which was printed (as it had been previously) at the end of the Burial Office. In 1661 the Apostolic Benediction was added, and thus the Collect has come to appear as if it was part of that Office on all occasions, instead of being intended only for those on which there is a celebration. In the Latin Prayer Book of 1560, the old title was translated with an addition:—"Celebratio cenæ Domini, in funebribus, si amici et vicini defuncti communicare velint," and so were the Epistle and two Gospels, the alternative one being John xxv. 24—29. The Puritans were extremely averse to any service at the burial of the dead², and wished to restrict the ceremonies to exhortation and preaching only. They objected to the Psalms, and these were given up till 1661; but as they had a peculiar aversion to the celebration of the Lord's Supper on any but very rare occasions, so its celebration at funerals was very distasteful to them, and was ignorantly associated by them with the Roman doctrine of purgatory. Thus the practice was much discouraged. When the Psalms were again printed in the Office, after a hundred years' suppression, the Gospel and Epistle were not; and the funeral Communion had almost passed out of memory in the first half of this century, the only relic of it being the funeral offertory, which still retained its hold upon the Church in Wales. But even this was deprived of its primitive character by being appropriated for fees by the clergyman, clerk, and sexton.

There are, however, sound reasons why the pious, ancient, and primitive custom should be observed.

(1) The Holy Eucharist is essentially a sacrificial act offered up for the departed as well as for the living. The petition in the Prayer of Oblation, "humbly beseeching Thee to grant that by

the merits and death of Thy Son Jesus Christ and through faith in His blood, we and all Thy whole Church may obtain remission of our sins and all other benefits of His passion," is one which includes the departed members of Christ's whole Church, or it would be only a petition for a portion of the Church; and "all other benefits of His passion" seems especially to apply to the departed, as "remission of our sins" applies to the living. "So that the virtue of this Sacrifice (which is here in this prayer of oblation commemorated and represented) doth not only extend itself to the living and those that are present, but likewise to them that are absent, and them that be already departed, or shall in time to come live and die in the faith of Christ³." At no time could this benefit be so appropriately sought, as when for the last occasion the body of the deceased Christian lies in front of the altar.

(2) A funeral Eucharist is also an act of communion with the departed, by which we make an open recognition of our belief that he still continues to be one of God's dear children; that the soul in Paradise and the body in the grave are still the soul and body of one who is still a member of Christ, still a branch (as much as those who remain alive) of the true Vine.

(3) The Holy Communion being the special means by which the members of Christ are brought near to their Divine Head, it is to it that the surviving friends of the deceased may look for their chief comfort in bereavement. By it they may look to have their faith strengthened in Him who has proclaimed Himself to be "The Resurrection and the Life:" and by the strengthening of their faith they may hope to see, even in the burial of their loved ones, the promise of a better resurrection when that which has borne the image of the earthly shall also bear the image of the Heavenly, when death shall be swallowed up in victory, and when God shall wipe away all tears from their eyes in the joy of a re-union before His Presence.

In the absence of any rubrical direction respecting the celebration of the Holy Communion at funerals, it seems desirable to follow the course pointed out by the Office for the Communion of the Sick, beginning the service with the Collect, and substituting that proper to the Office for that of the day. If an Introit is used, none can be more appropriate than the 42nd Psalm, which has been used at funerals for ages. The proper Epistle and Gospel are 1 Thess. iv. 13¹—18, and John vi. 37—40.

When they come to the Grave] Bishop Cosin altered this rubric as follows:—"¶ If there be any Divine Service to be read, or Sermon to be made at this time, the Corpse shall be decently placed in the midst of the Church till they be ended. Then all going in decent manner to the grave, while the Corpse is made ready," &c. By "Divine Service" Cosin doubtless meant the Holy Communion, as no other service was ever mixed up in this manner with the Burial Office⁴. Provision had been made for this in Edward VI.'s reign and in that of Queen Elizabeth. Sermons at funerals were also common when Cosin wrote, and for some time after; and were probably an adaptation to Church use of the Puritan practice which had sprung up during the Rebellion.

Clerks shall sing] This expression here and in the preceding rubric recognizes the presence of a choir as a matter of course; but their absence is provided for by the alternative direction for the Priest to say the Anthem alone.

¹ Aug. Conf. ix. 11, 12.

² "They would have no minister to bury their dead, but the corpse to be brought to the grave and there put in by the clerk, or some other honest neighbour, and so back again without any more ado."—Cosin, Works, v. 168. See also Hooker, Eccl. Polit., V. lxxv. 1. 4.

³ Cosin's Notes, Works, v. 352.

⁴ It is right to add, however, that at St. Paul's Cathedral the Burial Office has been sometimes amalgamated with Evensong, the proper Psalms and Lesson being substituted for those of the day.

Job xiv. 1, 2.
Ps. ciii. 15, 16.
1 Chron. xxix. 15.

MAN that is born of a woman hath but a short time to live, and is full of misery. He cometh up, and is cut down, like a flower; he fleeth as it were a shadow, and never continueth in one stay.

Prov. xxvii. 1.
James iv. 14.
2 Kings xx. 1—3.

In the midst of life we are in death : of whom may we seek for succour, but of thee, O Lord, who for our sins art justly displeased ?

Exod. xv. 11.
Ps. lxxxix. 6—8.
Isa. xxxiii. 14.

Yet, O Lord God most holy, O Lord most mighty, O holy and most merciful Saviour, deliver us not into the bitter pains of eternal death.

Ps. xxxviii. 9.
1 Pet. iii. 12.
Joel ii. 17.
Ps. cxvi. 3, 4.
xxiii. 4.
Acts vii. 59, 60.

Thou knowest, Lord, the secrets of our hearts; shut not thy merciful ears to our prayer; but spare us, Lord most holy, O God most mighty, O holy and merciful Saviour, thou most worthy Judge eternal, suffer us not, at our last hour, for any pains of death, to fall from thee.

HOMO natus de muliere brevi vivens tempore repletur multis miseriis. Qui quasi flos egreditur et conteritur : et fugit velut umbra, et nunquam in eodem statu permanet.

Salisbury Use.
In the Dirge.

A. Media vita in morte sumus :
Quem quærimus adiutorem nisi Te,
Domine ?

Lenten Ant. to
Nunc Dimittis.

Qui pro peccatis nostris juste irasceris.

Sancte Deus, Sancte Fortis, Sancte et misericors Salvator :

Amaræ morti ne tradas nos.

¶. Ne projicias nos in tempore senectutis :

Cum defecerit virtus nostra, ne derelinquas nos, Domine.

Sancte Deus, Sancte Fortis, Sancte et misericors Salvator :

Amaræ morti ne tradas nos.

¶. Noli claudere aures tuas ad preces nostras.

Sancte Fortis, Sancte et misericors Salvator :

Amaræ morti ne tradas nos.

¶. Qui cognoscis occulta cordis, parce peccatis nostris.

Sancte et misericors Salvator :

Amaræ morti ne tradas nos.

THE ANTHEM.

This was printed continuously until the last revision, when it was separated into paragraphs at the suggestion of Bishop Cosin. It was printed by the Reformers of 1549 in two portions, first, the two verses from Job; and, secondly, "In the midst of life," &c., the latter being translated (with some slight changes in the last paragraph) from an Anthem used at Compline on the third Sunday in Lent¹.

The use of this noble Anthem, Sequence, or Prose, at Burials is peculiar to the English Communion; and it never had a place in any part of the Roman Breviary. In some old German Breviaries it was appointed for a Compline Anthem on Saturdays, the usage being probably copied from that of Salisbury.

The original composition of the *Media vita* is traced back to Notker, to whom that of the *Dies Iræ* can be traced, and who was a monk of St. Gall, in Switzerland, at the close of the ninth century. It is said to have been suggested to him by a circumstance similar to that which gave birth to a noble passage in Shakespeare². As our English poet watched the samphire gatherers on the cliffs at Dover, so did Notker observe similar occupations elsewhere. And as he watched men at some "dangerous trade," he sang, "In the midst of life we are in death," moulding his awful hymn to that familiar form of the Trisagion, "Holy God, Holy and Mighty, Holy and Immortal, have mercy upon us," which is found in the primitive Liturgies. In the Middle Ages it was adopted as a Dirge on all melancholy occasions in Germany: armies used it as a battle song; and superstitious ideas of its miraculous power rose to such a height,

that in the year 1316 the Synod of Cologne forbade the people to sing it at all except on such occasions as were allowed by their Bishop. A version of it by Luther, "Mitten wir im Leben sind," is still very popular in Germany, as a hymn.

When sung to such strains as best its beautiful words, this Anthem has a solemn magnificence, and at the same time a wailing prayerfulness, which makes it unsurpassable by any analogous portion of any ritual whatever. It is the prayer of the living for themselves and for the departed, when both are in the Presence of God for the special object of a final separation (so far as this world and visible things are concerned), until the great Day. At such a season we do not argue about Prayers for the departed, but we pray them. For them and for ourselves we plead the mercies of the Saviour before the eternal Judge. Not as selfish men, to whom the brink of the grave brings thoughts of our own mortality, do we tremblingly cry out for fear; but as standing up before our dead who still live, as in anticipation of the Day when we shall again stand together, dying no more, before the Throne of the Judge, we acknowledge that Death is a mark of God's displeasure; that it is a result of sin, and that it ends in the bitter pains of an eternal death, unless the holy, mighty, and merciful Saviour deliver us. Such deep words of penitent humiliation on our own behalf, and on that of the person whose body is now to be removed from our sight, are a fitting termination to the last hour which is spent in the actual presence of those with whom we have, perhaps, spent many hours which need the mercy of God.

In the ancient Latin rite of the Church of England, the 114th Psalm, "When Israel came out of Egypt," was sung during the procession to the grave; and if the procession was long in going, the 25th Psalm also, "Unto Thee, O God, will I lift up my soul." The Antiphon to the Psalm was, "May the angels carry thee to Paradise: may the martyrs receive thee into their

¹ At Peterborough, part of the Sentences of the Burial Service were sung as the anthem during service on the Eve of the Annunciation [1642. Gunton, p. 99.]
² King Lear, iv. 6.

¶ *Then, while the earth shall be cast upon the body by some standing by, the Priest shall say,*

1 Sam. ii. 6.
Eccl. viii. 12.
xii. 7.
Gen. iii. 19.
xviii. 27.
Acts xxiv. 15.
John xi. 25.
Phil. iii. 20, 21.
John vi. 39. 40.
1 John iii. 2.

FORASMUCH as it hath pleased Almighty God of his great mercy to take unto himself the soul of our dear *brother* here departed, we therefore commit *his* body to the ground; earth to earth, ashes to ashes, dust to dust; in sure and certain hope of the Resurrection to eternal life, through our Lord Jesus Christ; who shall change our vile body, that it may be like unto his glorious body, according to the mighty working, whereby he is able to subdue all things to himself.

¶ *Then shall be said or sung,*

Rev. xiv. 13.

I HEARD a voice from heaven, saying unto me, Write, From henceforth blessed are the dead which die in the Lord: even so saith the Spirit; for they rest from their labours.

Finitis orationibus executor officii terram super corpus ad modum crucis ponat . . . *At the burial.*

COMMENDO animam tuam Deo Patri omnipotenti, terram terræ, cinerem cineri, pulverem pulveri, in nomine Patris, et Filii, et Spiritus Sancti.

AUDIVI vocem de cœlo dicentem: *Figils of the dead. Ant. to Magnificat.*
Beati mortui qui in Domino moriuntur.

assembly, and bring thee unto the City of the heavenly Jerusalem.”

Then, while the earth shall be cast] This striking ceremony was anciently performed by the Priest himself, and so the rubric directed in 1549; but was ordered to be performed by “some standing by” in 1552. The practice of casting it thrice appears to be one not peculiar to Christians, since it is referred to by Horace [Carm. I. xxviii. 35],

“ ———— licebit
Injeto ter pulvere curras.”

Bishop Cosin says, that it was the custom in most places for this to be done by the Priest in his day. In some parts of England four or five of the mourners usually assist the sexton in filling up the grave. Both customs arise out of that instinct of human nature that the Burial of the Dead is one of the works of mercy.

The original intention of the Office appears to have been, that the Priest should cast in the three symbolical handfuls of earth, saying the words of commendation, and that then the Anthem should be sung while the grave was being filled up by “some standing by.” This reconciles the rubric, the custom above

referred to, and Cosin’s words, “still the priest uses to cast the earth upon the corpse, before the clerk or sexton meddles with it” [Works, v. 168]. In the Greek Church the Priest casts earth on the body, saying, “The earth is the Lord’s and the fulness thereof, the compass of the round world, and they that dwell therein.” A touching memorial that the earth is sown with the bodies of the saints as Paradise is filled with their souls.

Forasmuch as it hath pleased] These words are founded on several texts of Scripture. “Then shall the dust return to the earth as it was; and the spirit shall return unto God who gave it” [Eccles. xii. 7]. “Behold now, I have taken upon me to speak unto the Lord, which am but dust and ashes” [Gen. xviii. 27]. “Dust thou art, and unto dust shalt thou return” [Gen. iii. 19]. “For our conversation is in heaven; from whence also we look for the Saviour, the Lord Jesus Christ; Who shall change our vile body, that it may be fashioned like unto His glorious body, according to the working whereby He is able to subdue all things unto Himself” [Phil. iii. 21].

The various forms in which these commendatory words have been cast may be seen at a glance by the following parallel arrangement:—

1549.	1552.	Proposed by Cosin.	1661.	Burial at Sea.
I commend thy soul to God the Father Almighty, and thy body to the ground; earth to earth, ashes to ashes, dust to dust;	Forasmuch as it hath pleased Almighty God . .	Forasmuch as it hath pleased Almighty God . .	Forasmuch as it hath pleased Almighty God . .	Forasmuch as it hath pleased Almighty God . .
in sure and certain hope of resurrection to eternal life, through our Lord Jesus Christ	in sure and certain hope of resurrection to eternal life, through our Lord Jesus Christ	in hope of a general and joyful resurrection to eternal life, through our Lord Jesus Christ	in sure and certain hope of the resurrection to eternal life through our Lord Jesus Christ	We therefore commit his body to the Deep, to be turned into corruption, looking for the resurrection of the body, (when the sea shall give up her dead), and the life of the world to come, through our Lord Jesus Christ . .

¹ “This is left arbitrary for any bystander to perform, by which it is implied that it shall be the state and condition of every one, one day. He that casts earth upon the dead body to-day may have earth cast upon his to-morrow, ‘Hodie mihi, cras tibi.’” Elborow on Occasional Offices, p. 115.

¶ *Then the Priest shall say,*

Lord, have mercy upon us.

Christ, have mercy upon us.

Lord, have mercy upon us.

OUR Father, which art in heaven, Hallowed be thy Name. Thy kingdom come. Thy will be done in earth, As it is in heaven. Give us this day our daily bread. And forgive us our trespasses, As we forgive them that trespass against us. And lead us not into temptation; But deliver us from evil. Amen.

Priest.

ALmighty God, with whom do live the spirits of them that depart hence in the Lord, and with whom the souls of the faithful, after they are delivered from the burden of the flesh, are in joy and felicity; We give thee hearty thanks, for that it hath pleased thee to deliver this our *brother* out of the miseries of this sinful world; beseeching thee, that it may please thee, of thy gracious goodness, shortly to accomplish the number of thine elect, and to hasten thy kingdom; that we, with all those that are departed in the true faith of thy holy Name, may have our perfect consummation and bliss, both in body and soul, in thy eternal and everlasting glory; through Jesus Christ our Lord. *Amen.*

Exod. iii. 6.
Luke xx. 38.
xxiii. 43.
xvi. 22.
2 Cor. v. 4.
Ps. xvii. 15.
xvi. 11.
Job i. 21.
Isa. lvii. 1, 2.
Rev. vi. 9-11.
Matt. xxiv. 31.
vi. 10.
Rom. ix. 28.
Rev. xxii. 20.
Heb. xi. 13, 39,
40.
2 Tim. iv. 8.
Rev. vii. 14-17.
xi. 15.

. . . *deinde sequatur.*

At the burial,

Kyrie eleison.

Christe eleison.

Kyrie eleison.

PATER noster, qui es in cœlis; sanctificetur nomen tuum: adveniat regnum tuum: fiat voluntas tua, sicut in cœlo, et in terra. Panem nostrum quotidianum da nobis hodie: et dimitte nobis debita nostra, sicut et nos dimittimus debitoribus nostris: et ne nos inducas in tentationem: sed libera nos a malo. Amen.

DEUS, apud quem spiritus mortuorum vivunt, et in quo electorum animæ, deposito carnis onere, plena felicitate lætantur, præsta supplicantibus nobis, ut anima famuli tui . . .

ALmighty God, we give thee hearty thanks for this thy servant, whom thou hast delivered from the miseries of this wretched world . . . Grant, we beseech thee, that at the day of judgment his soul, and all the souls of thy elect, departed out of this life, may with us, and we with them, fully receive thy promises, and be made perfect altogether; through the glorious resurrection of thy Son Jesus Christ our Lord.

Prayer Book of 1549.

The latter form has been substantially adopted by the American Church.

These words sometimes appear out of place when used over persons who have lived evil lives, and have not given evidence of dying penitent deaths. But it must be remembered that the Burial Office is framed on the supposition that it should be used only over those who are Christians; those, that is, who have been made members of Christ, children of God, and inheritors of the Kingdom of Heaven. If they have ceased to be Christians, they have no right to the use of the Office. But who have ceased to be Christians? And who would dare, of their own unauthorized judgment, to go against the spirit of the injunction laid on us by the Apostle, "Judge nothing before the time?" It may be regretted that the original form of 1549 was ever altered; but it is instructive to learn that the form adopted to please the Puritans of 1552 was thoroughly distasteful to the Puritans of 1661.

What the words do, in fact, express, is this:—That (1) The body of a Christian, our "dear brother" in Christ (even if an erring brother) is being committed to the ground. That (2) God has taken him to Himself in the sense that his spirit has "returned to God who gave it." That (3) while we thus commit the body of one to the ground, who (whatever he was, was yet a sinner) we do it with faith in a future Resurrection of all. That (4) without any expression of judgment as to our departed

brother, we will yet call that hope a "sure and certain hope," since it is founded on the Word of God.

There may be cases in which persons have died in the actual committal of some grievous sin, and in which these words might be manifestly unsuitable; but in such cases the whole Office is out of place, and the clergyman should decline to use it. And in almost all others, if not in all, there is room for an expression of hope, in the spirit of charity in which the Church appoints the words to be used; and as the Bishops replied to the Puritans in 1661, "It is better to be charitable and hope the best, than rashly to condemn."

Then the Priest shall say] In the Book of 1549 the Psalms and Lesson were directed to be said in the Church either before or after the burial of the corpse, "with other suffrages following." Those suffrages consisted of the lesser Litany and the Lord's Prayer, with these from the ancient Office.

Priest. Enter not (O Lord) into judgment with thy servant.
Answer. For in thy sight no living creature shall be justified.

Priest. From the gates of hell,

Answer. Deliver their souls, O Lord.

Priest. I believe to see the goodness of the Lord,

Answer. In the land of the living.

Priest. O Lord, graciously hear my prayer.

Answer. And let my cry come unto thee.

After which followed this prayer, of which that now in use is a

The Collect.

1 Pet. i. 3, 4.
 John xi. 25, 26.
 John v. 21, 24, 26.
 viii. 51.
 1 Thess. iv. 13, 14.
 Job xix. 25—27.
 Eph. ii. 1—5.
 1 Pet. ii. 24.
 Phil. iii. 8—11.
 Isa. lvii. 1, 2.
 John xi. 24.
 2 Tim. i. 18.
 2 Cor. v. 9.
 Rev. xiv. 13.
 John xiv. 2, 3.
 Math. xxv. 24.
 1 Pet. i. 3—5.
 Rom. v. 21

O MOST merciful God, the Father of our Lord Jesus Christ, who is the resurrection and the life; in whom whosoever believeth shall live, though he die; and whosoever liveth, and believeth in him, shall not die eternally; who also hath taught us, by his holy Apostle Saint Paul, not to be sorry, as men without hope, for them that sleep in him; We meekly beseech thee, O Father, to raise us from the death of sin unto the life of righteousness; that, when we shall depart this life, we may rest in him, as our hope is this our *brother* doth; and that, at the general Resurrection in the last day, we may be found acceptable in thy sight; and receive that blessing, which thy well-beloved Son shall then pronounce to all that love and fear thee, saying, Come, ye blessed children of my Father, receive the kingdom prepared for you from the beginning of the world: Grant this, we beseech thee, O merciful Father, through Jesus Christ our Mediator and Redeemer. *Amen.*

Collect.

O MERCIFUL God, the Father of our Lord Jesu Christ, who is the resurrection and the life; in whom whosoever believeth shall live, though he die; and whosoever liveth, and believeth in him, shall not die eternally; who also hath taught us, (by his holy Apostle Paul,) not to be sorry, as men without hope, for them that sleep in him; We meekly beseech thee, (O Father,) to raise us from the death of sin unto the life of righteousness; that, when we shall depart this life, we may sleep in him, as our hope is this our *brother* doth; and at the general Resurrection in the last day, both we, and this our brother departed, receiving again our bodies, and rising again in thy most gracious favour, may, with all thine elect saints, obtain eternal joy. Grant this, O Lord God, by the means of our Advocate Jesus Christ; which, with thee and the Holy Ghost, liveth and reigneth one God for ever. *Amen.*

Prayer Book of
 1549.
 Celebration of
 Holy Commu-
 nion at Burials.

. . . . Set him on the right hand of thy Son Jesus Christ, among thy holy and elect, that then he may hear with them these most sweet and comfortable words, Come to me, ye blessed of my Father, possess the kingdom which hath been prepared for you from the

Prayer Book of
 1549.
 Burial of the
 Dead.

modified form, "O Lord, with whom do live the spirits of them that be dead, and in whom the souls of them that be elected, after they be delivered from the burden of the flesh be in joy and felicity; Grant unto this Thy servant that the sins which he committed in this world be not imputed unto him; but that he escaping the gates of hell, and pains of eternal darkness, may ever dwell in the region of light, with Abraham, Isaac, and Jacob, in the place where is no weeping, sorrow, nor heaviness; and when that dreadful day of the general resurrection shall come, make him to rise also with the just and righteous, and receive this body again to glory, then made pure and incorruptible. Set him on the right hand of Thy Son Jesus Christ, among the holy and elect, that then he may hear with them these most sweet and comfortable words"

With this prayer the Office (excepting the celebration) ended from 1549 until the last revision in 1661, when the benediction was added.

The Collect] This most beautiful Collect properly belongs (as was previously shown) to the Office for the celebration of the Holy Communion at funerals, and hence its title. The first part of it is founded on the Gospel used at funerals when they took place on Sunday, and on the Epistle, which was used without variation, following in this many of the Collects for Sundays and other Holydays.

When the revision of 1552 took place, the Introits were uni-

formly removed from the Prayer Book, including that used in the Burial Office. The special Epistle and Gospel were also removed from the English Book, although retained in the Latin one. Hence the Collect only was left, and this was (according to the usual manner in which the Missal was printed) placed with the other parts of the Service for use when required. In 1661 the Apostolic Benediction was placed after it; and thus led to its being regarded as part of the ordinary Burial Service, even when there is no celebration of the Holy Eucharist. The Communion Collect being used at Morning and Evening Prayer, analogy *permits* the use of the Funeral Communion Collect in the Funeral Service without Communion; but probably its omission in such cases is strictly the proper rule.

When there is a Celebration, this Collect takes the place of the Collect for the day, and should not be repeated at the grave after having been said at the Altar.

The latter part of the prayers is translated from that belonging to the "Missa de quinque vulneribus," in the Sarum Missal: "Domine Jesu Christe, Fili Dei vivi: qui de coelo ad terram de sinu Patris descendisti; et in ligno crucis quinque plagas sustinuisti: et sanguinem tuum preciosum in remissionem peccatorum nostrorum studisti; Te humiliter deprecamur ut in die judicii ad dexteram Tuam statuti a Te audire mereamur illam vocem dulcissimam, Venite, benedicti, in regnum Patris mei. Qui cum eodem Patre in unitate. Per."

[A. D. 1661.]
2 Cor. xiii. 14.

THE grace of our Lord Jesus Christ, and the love of God, and the fellowship of the Holy Ghost, be with us all evermore. *Amen.*

beginning of the world. Grant this, we beseech thee, O merciful Father, through Jesus Christ, our Mediator and Redeemer. *Amen.*

The grace of our Lord] This was inserted here by Bishop Cosin, who at first wrote out for insertion, "The blessing of God Almighty the Father, the Son, and the Holy Ghost, be amongst

you, and remain with you always;" thus illustrating the form in which that Benediction should be used when not given at the Holy Communion.

§ APPENDIX TO THE BURIAL OFFICE.

[I.]

There are few persons who have not felt the want of prayers which they could use with definite reference to a departed relative or friend while the body of the deceased was yet waiting to be carried to the grave. To ignore the departed at such a season, when we are praying to our heavenly Father in the Communion of Saints, is repugnant to Christian feeling; nor can those who have a vivid sense of the intermediate state feel any hesitation in praying for a continuance of His mercy to the soul which has just entered upon it.

Although there is no direct command in Holy Scripture respecting Prayers for the departed, there are several indirect pieces of evidence that the use of them was habitual to Christians of the Apostolic age, as it had been to the Jews, and as it was to the Christians of the Primitive Church after the Apostles. St. Paul offers a prayer for Onesiphorus in the words, "The Lord grant unto him that he may find mercy of the Lord in that day." [2 Tim. i. 18.] That Onesiphorus was not then living seems to be proved, (1) by the omission of his name from the salutation, which shows that he was neither at Rome nor at Ephesus: (2) by the manner in which St. Paul speaks of his association with him as belonging to that which was long past and gone by: (3) by the salutation sent to *the household* of Onesiphorus, as if he were not now one of that household: (4) by the direction of the prayer towards the day of judgment, and not to the time of grace and probation. In another Epistle St. Paul enjoins on the Ephesians that they should offer intercessory prayer as well as prayer for themselves; "praying alway with all prayer and supplication in the Spirit, and watching thereunto with all perseverance and supplication for all saints." [Eph. vi. 18.] This inclusive phrase is one which brings to mind the sense in which it is used on "All Saints' Day, of the departed in Christ, and also the passage of Scripture respecting our Lord's Resurrection, in which it is said also that "many bodies of the saints which slept arose." [Matt. xxvii. 52¹.]

Every primitive Liturgy that exists contains prayers for the departed, and the works of early Christian writers make innumerable references to the habit as one which was evidently as familiar to them as that of praying for the living. Some specimens of such primitive intercessions will be found in an

¹ The books of Maccabees were probably written in the century before our Lord, and the habit of the Jews is shown by what is recorded of Judas Maccabeus: "When he had made a gathering throughout the company to the sum of two thousand drachms of silver, he sent it to Jerusalem to offer a sin offering, doing therein very well and honestly, in that he was mindful of the resurrection. For if he had not hoped that they which were slain should have risen again, it had been superfluous and vain to pray for the dead. And also in that he perceived that there was great favour laid up for those that died godly, it was a holy and good thought. Whereupon he made a reconciliation for the dead that they might be delivered from sin" [2 Mac. xii. 43].

earlier part of this volume, in the notes to the Liturgy. In short, it may be said that no one ever thought of *not* praying for the departed until in comparatively recent times; and when the question whether such prayers were lawful or not in the Church of England was brought before a court of ecclesiastical law, Sir Herbert Jenner, the judge, proved, and decided, that they were constantly recognized by our holiest Divines since the Reformation.

But few have written more wisely and feelingly on this subject than the holy Bishop Heber:

"Having been led attentively to consider the question, my own opinion is on the whole favourable to the practice, which indeed is so natural and so comfortable, that this alone is a presumption that it is neither displeasing to the Almighty nor unavailing with Him.

"The Jews so far back as their opinions and practices can be traced since the time of our Saviour, have uniformly recommended their deceased friends to mercy; and from a passage in the second Book of Maccabees, it appears that (from whatever source they derived it) they had the custom before His time. But if this were the case the practice can hardly be unlawful, or either Christ or His Apostles would, one should think, have in some of their writings or discourses condemned it. On the same side it may be observed, that the Greek Church and all the Eastern Churches, though they do not believe in purgatory, pray for the dead; and that we know the practice to have been universal, or nearly so, among the Christians little more than 150 years after our Saviour. It is spoken of as the usual custom by Tertullian and Epiphanius. Augustine, in his Confessions, has given a beautiful prayer, which he himself used for his deceased mother, Monica; and among Protestants, Luther and Dr. Johnson are eminent instances of the same conduct. I have accordingly been myself in the habit for some years of recommending on some occasions, as after receiving the Sacrament, &c., &c., my lost friends by name to God's goodness and compassion through His Son, as what can do them no harm, and *may*, and I hope *will*, be of service to them. Only this caution I always endeavour to observe—that I beg His forgiveness at the same time for myself if unknowingly I am too presumptuous, and His grace lest I, who am thus solicitous for *others*, should neglect the appointed means of my own salvation?"

It has been thought therefore that the following Collect from the ancient Vesper Office for the Departed will be acceptable to many, as one that may be incorporated with their private or their household prayers, together with such Psalms as the 42nd, 121st, and 130th:—

O GOD, whose nature and Deum, cui proprium est misericorditer sepe et parcere; te suppliciter deprecamur pro animae petitionibus pro thei fauuli tui (vel famulae tuae),

² Diaries of a Lady of Quality, p. 196.

servant whom Thou hast [this day] called to depart out of this world; and because Thy servant hoped and believed in Thee, we beseech Thee that Thou wilt neither suffer *him* to fall into the hand of the enemy, nor forget *him* for ever; but wilt give Thine holy angels charge to receive *his* soul, and to transport it into the land of the living, there to be found worthy to rejoice in the fellowship of Thy saints; through Jesus Christ our Lord, who ever liveth and reigneth with Thee in the Unity of the Holy Ghost, one God, world without end. *Amen.*

quam hodie de hoc sæculo migrare jussisti; ut non tradas eam in manus inimici, nec obliviscaris in finem; sed jubeas illam ab angelis sanctis suscipi, atque ad regionem vivorum perducere; et quia in te speravit et credidit, sanctorum tuorum mereatur societate lætari. Per Dominum nostrum Jesum Christum Filium tuum, qui tecum vivit et regnat in unitate Spiritus Sancti Deus, Per omnia sæcula sæculorum.

[II.]

In the Primitive Church, and in the Church of England before the Reformation, it was the custom to celebrate a Service of Commemoration on the Anniversaries of the death of a friend, relative, or benefactor. These services were, of course, only continued for a time, according to the provision made by survivors or by the will of the deceased persons. And, as is well known, they too often degenerated into superstition, in connexion with the erroneous dogma put forth by the Roman Church respecting the Intermediate State of departed souls.

The principle of such services has, however, been retained in the Church of England to the present day; and the following two Offices offer an illustration of the manner in which that principle is carried out in the language of modern devotion. The first is used in the Chapel Royal, Windsor, once in every quarter. The second (which varies in some respects) is used in the Colleges of Oxford and Cambridge (though neglected in some) once during every term; and is substantially the same as that which was authorized in the Latin Prayer Book of 1560. The particular form printed here is that used at Trinity College, Cambridge. That of Queen Elizabeth is also given.

(A)

“THE SERVICE APPOINTED FOR OBIT SUNDAY.

Proper Psalms { XXI.
CXLVI.
CXLVII.

The First Lesson. Ecclesiasticus xlv.

The Second Lesson. Hebrews xi.

These two Collects following are read daily at Morning and Evening Prayer, immediately before the Prayer of St. Chrysostom.

ALMIGHTY God, we beseech Thee to keep Thy servant *VICTORIA*, our most gracious Queen and Governor, and so rule her heart in Thy Faith, Fear, and Love, that evermore she may have Affiance and Trust in Thee, and ever seek Thy Honour and Glory, through Jesus Christ our Lord. *Amen.*

GOD save our gracious Sovereign, and all the Companions of the most Honourable and Noble Order of the Garter. *Amen.*

In the Communion Service, the portion of Scripture for the Epistle is Deuteronomy xxxiii.

The Gospel is St. John v. verse 24 to 30.

The following PRAYERS are used immediately after the *Gloria in Excelsis Deo.*

Priest.

O Lord, save our Queen.

Choir.

And mercifully hear us when we call upon Thee.

O LORD our heavenly Father and merciful Saviour Jesus Christ, assist our most worthy Queen continually with Thy Holy Spirit, that as she is anciently and truly descended from the noble Princes of this Realm, and the bountiful Patrons and Founders of this noble Order and Church, so she may proceed in all good works; namely, for sustentation of Learning, and help of Poverty; and that all Noblemen of this Realm (especially such as be Companions of this most honourable Order of the Garter) may likewise dispose themselves in Honour and Virtue at all times, that God thereby may be the better honoured, the Commonwealth served, and their Fame remain to their Posterity; and that we all may continue in the true Faith, and walk in good Works, that God hath appointed us, through Jesus Christ our Lord. *Amen.*

WE praise and thank Thee, O Lord, in all the noble Kings, Patrons, and Founders of this Order, and our Benefactors Thy Servants, humbly beseeching Thy Majesty, that as they for their time honourably and charitably did bestow their gifts to our relief, so we may faithfully use them, to the end that thereby others may be moved by such examples, to provide for good and learned Ministers to teach Thy Word, and to be merciful in relieving the Poor, through Jesus Christ our Lord and Saviour. *Amen.*

GOD save our gracious Sovereign, and all the Companions of the most Honourable and Noble Order of the Garter. *Amen.*

(B)

“Forma Commendationis Fundatoris, et aliorum Benefactorum.

Primo recitetur, Pater noster, &c.

Deinde decantentur hi tres Psalmi;

Exaltabo Te, Deus. Psal. 145.

Lauda, anima mea, Dominum. Psal. 146.

Laudate Dominum. Psal. 147.

Post hæc legatur caput 44 Ecclesiastici

Tum unus e Concionatoribus concionem habeat.

Finita concione, decantentur Hymnus sequens.

Verse and Chorus.

Oh, give thanks unto the Lord.

SOLO *Contra-Tenor.*

The righteous shall be had in everlasting remembrance, and the just as the brightness of the firmament.

Verse and Chorus.

Blessed be the Lord God of Israel, for everlasting, and let all the people say, Amen.

Ad extremum hæc oratio adhibeatur;

Minister.

The memory of the righteous shall remain for evermore;

Chorus.

And shall not be afraid of any evil report.

Minister.

The souls of the righteous are in the hand of God;

Chorus.

Neither shall any grief hurt them.

Minister.

The Lord be with you;

Chorus.

And with thy Spirit.

Let us give thanks.

O LORD, who art the resurrection and the life of them that believe, who always art to be praised, as well in those that live as in those that are departed; we give Thee thanks for King HENRY the Eighth our Founder, Queen MARY, EDWARD the Third, HERVEY of STANTON, and others our Benefactors, by whose Beneficence we are here maintained for the farther attain-

ing of godliness and learning; beseeching Thee to grant, that we, well using to Thy glory these Thy gifts, may rise again to eternal life, with those that are departed in the faith of Christ, through Christ our Lord. *Amen.*

THE grace of our Lord Jesus Christ, and the love of God, and the fellowship of the Holy Ghost, be with us all evermore. *Amen.*"

The following is the Elizabethan form of this Office:—

IN COMMENDATIONIBUS BENEFACTORUM.

Ad cujusque termini finem, commendatio fiat fundatoris, aliorumque clarorum virorum, quorum beneficentia Collegium locupletatur. Ejus hæc sit forma.

Primum recitetur clara voce Oratio dominica.

Pater noster qui es in cælis. &c.

Deinde recitentur tres Psalmi.	}	Exaltabo te Deus meus rex. Psalms. 144. Lauda anima mea Do. 145. Laudate Dominum, quoniam bonus. Psalmus. 146.
-----------------------------------	---	--

Posthæc legatur caput 44. Ecclesiastici.

His finitis, sequatur concio, in qua concionator Fundatoris amplissimam munificentiam prædicet: quantus sit literarum usus ostendat: quantis laudibus afficiendi sunt, qui literarum studia beneficentia sua excitent: quantum sit ornamentum Regno doctos viros habere, qui de rebus controversis vere judicare possunt: quanta sit scripturarum laus, & quantum illæ omni humanæ auctoritati antecedant, quanta sit ejus doctrinæ in vulgus utilitas, & quam late patent: quam egregium & regium sit (cui Deus universæ plebis suæ curam commisit) de multitudine ministrorum verbi laborare, atque hi ut honesti atque eruditi sint, curare: atque alia ejus generis, quæ pii & docti viri cum laude illustrare possint.

Hac Concione perorata decantetur.

Benedictus Dominus Deus Israel.

Ad extremum hæc adhibeantur.

Minister. In memoria æterna erit justus.

Responsio. Ab auditu malo non timebit.

Minister. Justorum animæ in manu Dei sunt.

Responsio. Nec attinget illos cruciatus.

Oremus.

Domine Deus, resurrectio & vita credentium, qui semper es laudandus, tam in viventibus, quam in defunctis, agimus tibi gratias pro fundatore nostro N. ceterisque benefactoribus nostris, quorum beneficiis hic ad pietatem & studia literarum alimur: rogantes, ut nos his donis ad tuam gloriam recte utentes, una cum illis ad resurrectionis gloriam immortalem perducamur. Per Christum Dominum nostrum. Amen.

[III.]

The following is the actual form authorized in 1560 for the celebration of the Holy Communion at Funerals:—

CELEBRATIO CENÆ DOMINI, IN FUNEBRIBUS, SI AMICI & VICINI DEFUNCTI COMMUNICARE VELINT.

Collecta.

Misericors Deus, Pater Domini nostri Jesu Christi, qui es resurrectio & vita, in quo qui credit, etiamsi mortuus fuerit, vivet; & in quo qui crediderit & vivit, non morietur in æternum: quique nos docuisti per sanctum Apostolum tuum Paulum, non debere morere pro dormientibus in Christo, sicut ii qui spem non habent resurrectionis: humiliter petimus, ut nos a morte peccati resuscites ad vitam justitiæ, ut cum ex hac vita emigramus, dormiamus cum Christo, quemadmodum speramus hunc fratrem nostrum, & in generali resurrectione, extremo die, nos una cum hoc fratre nostro resuscitati, & receptis corporibus, regnemus una tecum in vita æterna. Per Dominum nostrum Jesum Christum.

Epistola. 1 Thess. iiii.

Nolo vos ignorare, fratres, de his qui obdormierunt, Proinde consolemini vos mutuo sermonibus his.

Evangelium. Joan. vi.

Dixit Jesus discipulis suis, & turbis Judæorum: Omne quod dat mihi Pater habeat vitam æternam, & ego suscitabo eum in novissimo die.

Vel hoc Evangelium. Joan. v.

Dixit Jesus discipulis suis, & turbis Judæorum: Amen, Amen, dico vobis, qui sermonem meum audit qui vero mala egerunt, in resurrectionem condemnationis.

THE THANKSGIVING OF
WOMEN AFTER CHILD-
BIRTH,

COMMONLY CALLED,

THE CHURCHING OF WOMEN

¶ *The woman, at the usual time after her delivery, shall come into the church decently apparelled, and there shall kneel down in*

Salisbury Use.

ORDO AD PURIFICANDAM
MULIEREM POST PARTUM,
ANTE OSTIUM ECCLESIAE.

THE CHURCHING OF WOMEN.

This Service underwent scarcely any change in the transition of our Offices from the old English system to the new. In 1549 the ancient title was retained, the "quire door" was substituted for the door of the Church, and the address at the commencement of the Service was substituted for that at the end of the old one. In 1552 the present Title was adopted, and "the place where the table standeth" put instead of "the quire door." In 1661 the two Psalms now in use were substituted for the 121st: the second of them being added to the 121st by Bishop Cosin, but the 116th afterwards inserted instead of it.

Although the Churching Service does not appear in the ancient Sacramentaries, very ancient Offices for the purpose are to be found in the rituals of the Western and Eastern Churches, which are given in the pages of Martene and Goar. The practice itself is referred to in St. Gregory's answer to the questions of St. Augustine [A.D. 601]. The latter had asked, "How long must it be before a woman comes to Church after childbirth?" and St. Gregory's reply contains the exact expression now adopted as the title of the Service¹: "In how many days after her delivery a woman may enter into the church you have learned from the Old Testament . . . Yet if she enter into the church to make her thanksgiving [actura gratias] the very hour in which she gives birth, there is not to be considered as doing that which is sinful." There is a still more ancient reference to the practice in the seventeenth constitution of the Emperor Leo, published about A.D. 460. In both cases the custom is mentioned in such a way as to give the impression that it was a familiar and established one; but there appears to have been a frequent difficulty as to the interval which should be allowed after childbirth before the thanksgiving was made. It is not unreasonable, therefore, to conclude that the Churching of Women is a primitive practice derived from the Jews; and that its adoption by the Christian Church was accompanied by some doubts as to the extent to which the law of God respecting it, as given to the Jews, was to be literally obeyed.

This Christian custom is not founded, however, on the Jewish law alone, but on those first principles of religion to which human nature was subjected from the time of the Fall. The word of God to Eve was, "In sorrow thou shalt bring forth children;" and the first words of Eve afterwards are on the birth of Cain; when, as the psalm says, "Lo, children and the fruit of the womb are an heritage and gift that cometh of the Lord," so the mother of all living said, "I have gotten a

man from the Lord." This sense of the Providence of God in the matter of child-bearing, and also of the sorrow and pain which He has connected with it on account of Eve's transgression, must ever lead instinctively to thanksgiving, and to a religious recognition of His goodness in giving safe deliverance. The same principles extend themselves also further than this; and, acknowledging that original sin is inherited by children from their parents, enjoin upon the mother the duty of recognizing this also by a ceremonial return to the Church with humble prayers.

This service was not formerly used for unmarried women until they had done penance. So Archbishop Grindal² enjoined in 1571. So also the Bishops replied to those who excepted against this service for the mothers of bastard children in 1661: "If the woman be such as is here mentioned, she is to do her penance before she is churched."

[*at the usual time*] The first Rubric as altered by Bishop Cosin in the Durham book stands thus,—*"The woman, a month after delivery, being recovered, shall, upon some Sunday or other Holyday, come decently vayed into the Parish Church, and at the beginning of the Communion Service shall kneel down in some convenient place appointed unto her by the Minister before the Holy Table; at which he standing shall thus direct his speech to her."*

[*decently apparelled*] In Archdeacon Hale's Precedents there are several presentations of clergymen for refusing to church women who did not wear veils or kerchiefs when they came to their thanksgivings, and of women for coming without them: "The said Tabitha did not come to be churched in a vaille" [p. 259]. "Presentatur, for that she being admonished that when she came to church to give God thanks for her safe deliverance in childbirth, that she should come with such ornaments as other honest women usually have done, she did not, but coming in her hat and a quarter about her neck, sat down in her seat where she could not be descried, nor seen unto what the thanksgiving was read" [p. 237]. It is evident from such records as these that some distinctive dress was considered desirable in former times; and that a veil was thought to be a token of modesty better befitting such an occasion than a mere ordinary head-dress. In an inventory of Church goods belonging to St. Benet's Gracechurch in 1560, there is "a churching-cloth fringed, white damask;" from which it would seem that the veil was in some cases provided by the Church. Elborow speaks

² "That they should not church any unmarried woman, which had been gotten with child out of lawful matrimony; except it were upon some Sunday or holyday; and except either she, before childbed, had done penance, or at her churching did acknowledge her fault before the congregation." Cardw. Doc. Ann., i. 335.

¹ In the rubric at the beginning of this Office, in the Greek ritual, the phrase ἐπι τῆ ἐκκλησιασθῆναι is used. Goar, p. 267.

some convenient place, as hath been accustomed, or as the Ordinary shall direct: And then the Priest shall say unto her,

Gen. iii. 16 with
1 Tim. ii. 14, 15.
Lev. xii. 6, 7 with
Luke ii. 21—24.

FORASMUCH as it hath pleased Almighty God of his goodness to give you safe deliverance, and hath preserved you in the great danger of child-birth; you shall therefore give hearty thanks unto God, and say,

[¶ *Then shall the Priest say the cxvith Psalm.*]

Dilexi quoniam.

¶ *Or, Psalm cxxvii. Nisi Dominus.*

¶ *Then the Priest shall say,*

Let us pray.

Lord, have mercy upon us.

Christ, have mercy upon us.

Lord, have mercy upon us.

OUR Father, which art in heaven, Hallowed be thy Name. Thy kingdom come. Thy will be done in earth; As it is in heaven. Give us this day our daily bread. And forgive us our trespasses, As we forgive them that trespass against us. And lead us not into temptation; But deliver us from evil: For thine is the kingdom, The power, and the glory, for ever and ever. Amen.

Minister.

Ps. lxxxvi. 2. O Lord, save this woman thy servant;

Answer.

Who putteth her trust in thee.

Minister.

Ps. lxi. 3. Be thou to her a strong tower;

¶ *Primo sacerdos et ministri ejus dicant psalmos Ps. cxxi. and sequentes. Ps. Levavi oculos meos. Ps. cxxviii Beati omnes. Gloria Patri. Sicut erat.*

Sequatur.

Kyrie eleison.

Christe eleison.

Kyrie eleison.

PATER noster, qui es in caelis; sanctificetur nomen tuum: adveniat regnum tuum: fiat voluntas tua, sicut in caelo, et in terra. Panem nostrum quotidianum da nobis hodie: et dimitte nobis debita nostra, sicut et nos dimittimus debitoribus nostris: et ne nos inducas in tentationem: sed libera nos a malo. Amen.

Domine, salvam fac ancillam tuam.

Deus meus sperantem in te.

Esto ei, Domine, turris fortitudinis.

of the veil being commonly used in the latter half of the 17th century, but adds that it was "scrupled" against by some as if the wearing it were a gross sin.

[*convenient place*] The place assigned by the Rubric before the Reformation was the Church door. In 1549 this was altered to the Quire door; and "nigh unto the table" in 1552. Now that the place is left to the clergyman's appointment, he will have to consider that the spirit of the Rubric has always been to symbolize by the woman's position during her Churching that she is being re-admitted to Church privileges and Divine worship. The Church door is not suited to modern climates and constitutions, but the Choir door seems a very fitting place, and was used by Bishop Andrewes. In the book referred to in the last note, a Churching "stool" or form is referred to, which probably indicates a seat near to the Church door. The tenth of Bishop Wren's orders and injunctions for the diocese of Norwich, in 1636, enjoins, "That women to be churched come and kneel at a side near the communion table without the rail, being veiled according to the custom, and not covered with a hat; or otherwise not to be churched, but presented at the next generals by the minister, or churchwardens or any of them." In Bishop

Brian Duppa's Articles of Visitation of 1638, there is a similar one:—"Doth he go into the Chancel, the woman also repairing thither, kneeling as near the Communion Table as may be; and if there be a Communion, doth she communicate in acknowledgment of the great blessing received by her safe delivery? Doth the woman who is to be Churched use the accustomed habit in such cases with a white veil or kerchief upon her head?"

[*Then shall the Priest say*] It may be doubted whether it was ever intended that the priest should say this alone. As the old Rubric directed the choral use of the Psalm, and as that in the Marriage Service is to be used in the same way (the very Psalm that formerly stood here), so no doubt it was meant that this should be used as other Psalms are. It has sometimes been used processionally in the same manner as an Introit, to which it bears a close analogy. The Priest should stand during the whole of the Service.

The 116th Psalm is most appropriate where the woman is going to communicate after her Churching; or where her sorrows have been added to by the death of her infant, in which latter case the 127th Psalm is very inopportune.

R R

Answer.

From the face of her enemy.

Minister.

Ps. lxi. 1.

Lord, hear our prayer.

Answer.

And let our cry come unto thee.

Minister.

Let us pray.

Ps. cxvi. 8, 10.
12, 17—19.
John xvi. 21.
Ps. cxxiv. 8.
Heb. iv. 16.
Deut. xxiii. 23.
Gal. ii. 20.
Col. ii. 6, 7.
2 Pet. i. 10, 11.

O ALMIGHTY God, we give thee humble thanks for that thou hast vouchsafed to deliver this woman thy servant from the great pain and peril of child-birth; Grant, we beseech thee, most merciful Father, that she, through thy help, may both faithfully live, and walk according to thy will in this life present; and also may be partaker of everlasting glory in the life to come; through Jesus Christ our Lord. *Amen.*

2 Sam. xxiv. 24.
Ps. cxvi. 10—14.

¶ *The woman, that cometh to give her thanks, must offer accustomed offerings; and, if there be a Communion, it is convenient that she receive the holy Communion.*

A facie inimici.

Domine, exaudi orationem meam.

Et clamor meus ad te veniat.

Dominus vobiscum.

Et cum spiritu tuo.

Oremus.

DEUS qui hanc famulam tuam de pariendo periculo liberasti, et eam in servitio tuo devotam esse fecisti, concede ut temporali cursu fideliter peracto, sub alis misericordiae tuae vitam perpetuam et quietam consequatur. Per Christum Dominum.

[*Tunc aspergatur mulier aqua benedicta: deinde inducat eam sacerdos per manum dextram in ecclesiam, dicens: Ingredere in templum Dei ut habeas vitam æternam et vivas in sæcula sæculorum. Amen.*]

offerings] A due to the Priest offered on the Altar. Compare the words "Easter Offering" and "Easter Dues." So Bishop Andrewes interprets it, and so Hooker, V. lxxiv. 4. The Chrisom was formerly included.

● *it is convenient that she receive*] As the Churching Service is a restoration of the woman to the privileges of the Lord's house, it is clear that it should be said at the beginning of that is, before, any service at which she is to be present for the first time after her recovery. If she is to communicate, a convenient time would be immediately before the Lord's Prayer and Collect for purity, supposing she has not been present at Litany and

Mattins; and such a use of this service would doubtless be nearest to the intention of the Church in every way. Bishop Sparrow says that this time was mentioned in Visitation Articles, and Bishop Wren's directions expressly enjoin it; adding that if there is a marriage, the Churching is to come immediately next to the Communion Service after the conclusion of that for the Marriage. In Bishop Cosin's revised Book he began this rubric, "the Priest here goeth to the Communion Service." This rule about Holy Communion clearly excludes impenitent unmarried women from "Churching." *Convenient* is a word that meant "fitting" more distinctly in former days than now.

A COMMINATION,

OR,

Denouncing of God's anger and judgments against sinners, with certain prayers, to be used on the first day of Lent, and at other times, as the Ordinary shall appoint.

¶ *After Morning Prayer, the Litany ended according to the accustomed manner, the Priest shall, in the Reading-Pew or Pulpit, say,*

¶ *Feria iiii. in capite Jejuni: post sextam in Salisbury Use. primas fiat sermo ad populum si placuerit. . . .*

1 Cor. v. 4-7. 11.
13.
1 Tim. v. 20.
Deut. xvii. 12, 13.
Matt. xviii. 15-18.

BRETHREN, in the Primitive Church there was a godly discipline, that, at the beginning of Lent, such persons as stood convicted of notorious sin were put to open penance, and punished in this world, that their souls might be saved in the day of the Lord; and that others, admonished by their example, might be the more afraid to offend.

Instead whereof, (until the said discipline may be restored again, which is much to be wished,) it is thought good, that at this time (in the presence of you all) should be read the general sentences of God's cursing against impenitent sinners, gathered out of the seven and twentieth Chapter of Deuteronomy, and other places of Scripture; and that ye should answer

Deut. xxvii. 11-15.

to every Sentence, *Amen*: To the intent that, being admonished of the great indignation of God against sinners, ye may the rather be moved to earnest and true repentance; and may walk more warily in these dangerous days; fleeing from such vices, for which ye affirm with your own mouths the curse of God to be due.

Neh. viii. 1-3.
ix. 1-3.
Ps. vii. 11, 12.
Rom. ii. 8, 9.
Joel ii. 16, 17.
Eph. v. 15.
2 Tim. ii. 19.

CURSED is the man that maketh any carved or molten image, to worship it.

Deut. xxvii. 16.

¶ *And the people shall answer and say, Amen.*

Minister.

Cursed is he that curseth his father or mother.

Deut. xxvii. 16.

Answer.

Amen.

THE COMMINATION.

This is an adaptation of an ancient service which was said between Prime and Mass on Ash-Wednesday. The first part of this service may be understood from the portion incorporated into our own as shown by the Latin; six other collects and an absolution, which followed the collect *Exaudi, quæsumus*, not being included. After the absolution began the service for the Benediction of the Ashes, consisting of a Collect (which forms the substance of the one beginning, "O most mighty God"), the Benediction and Distribution of the ashes, and an anthem sung while the latter was going on. The Anthem and the Epistle of the succeeding Mass are the foundation of the solemn confession with which the Commination originally ended. "Through the merits," &c., "The Lord bless us and keep us," were added by Bishop Cosin at the Revision of 1661. He also proposed to alter "punished" in the opening homily to "did humbly submit themselves to undergo punishment," and succeeded in substituting "stood convicted of notorious sin" for the original words "were notorious sinners."

Reading-Pew or Pulpit] The reading-pew does not mean a reading-desk, but the chancel, pew, or stalls occupied by the

Clergy and singers. The "pulpit" is probably the "Jube," a lectern on the top of the chancel-screen¹, from which the Epistle and Gospel were read in ancient days, and from which they were ordered to be read by Bishop Grindal and others in their diocesan injunctions. Pulpits as now understood were extremely rare in Parish Churches for a long time after the Reformation, and "reading-desks" are of comparatively modern introduction. The modern preaching-pulpit is certainly not the place for the Priest when taking his part in a responsive service; and now that the ancient Jube is disused for the Epistle and Gospel, it is most proper to follow the analogy of usage in respect to them, and read the Commination Service from the front of the Altar. The analogy between the maledictions and the Decalogue leads to the same conclusion. As the services out of which this was formed immediately preceded the Mass of the day, so no doubt it was intended that the Commination should precede, with some slight interval, the Ash-Wednesday celebration of the Holy Communion.

at other times] The Commination Service has not been used

¹ See Davies's Rites of Durham; and also Cosin's Works, v. 383.

	<i>Minister.</i>	
<i>Deut. xxvii. 17.</i>		Cursed is he that removeth his neighbour's land-mark.
	<i>Answer.</i>	Amen.
	<i>Minister.</i>	
<i>Deut. xxvii. 18.</i>		Cursed is he that maketh the blind to go out of his way.
	<i>Answer.</i>	Amen.
	<i>Minister.</i>	
<i>Deut. xxvii. 19.</i>		Cursed is he that perverteth the judgement of the stranger, the fatherless; and widow.
	<i>Answer.</i>	Amen.
	<i>Minister.</i>	
<i>Deut. xxvii. 24.</i>		Cursed is he that smiteth his neighbour secretly.
	<i>Answer.</i>	Amen.
	<i>Minister.</i>	
<i>Lev. xx. 10.</i>		Cursed is he that lieth with his neighbour's wife.
	<i>Answer.</i>	Amen.
	<i>Minister.</i>	
<i>Deut. xxvii. 25.</i>		Cursed is he that taketh reward to slay the innocent.
	<i>Answer.</i>	Amen.
	<i>Minister.</i>	
<i>Jer. xvii. 5.</i>		Cursed is he that putteth his trust in man, and taketh man for his defence, and in his heart goeth from the Lord.
	<i>Answer.</i>	Amen.
	<i>Minister.</i>	
<i>Matt. xxv. 41.</i> <i>1 Cor. vi. 9, 10.</i>		Cursed are the unmerciful, fornicators, and adulterers, covetous persons, idolators, slanderers, drunkards, and extortioners.
	<i>Answer.</i>	Amen.

Minister.

NOW seeing that all they are accursed (as the prophet David beareth witness) who do err and go astray from the commandments of God; let us (remembering the dreadful judgement hanging over our heads, and always ready to fall upon us) return unto our Lord God, with all contrition and meekness of heart; bewailing and lamenting our sinful life, acknowledging and confessing our offences, and seeking to bring forth worthy fruits of penance. For now is the axe put unto the root of the trees, so that every tree that bringeth not forth good fruit is hewn down, and cast into the fire. It is a fearful thing to fall into the hands of the living God: he shall pour down rain upon the sinners, snares, fire and brimstone, storm and tempest; this shall be their portion to drink. For lo, the Lord is come out of his place to visit the wickedness of such as dwell upon the earth. But who may abide the day of his coming? Who shall be able to endure when he appeareth? His fan is in his hand, and he will purge his floor, and gather his wheat into the barn; but he will burn the chaff with unquenchable fire. The day of the Lord cometh as a thief in the night: and when men shall say, Peace, and all things are safe, then shall sudden destruction come upon them, as sorrow cometh upon a woman travailing with child, and they shall not escape. Then shall appear the wrath of God in the day of vengeance, which obstinate sinners, through the stubbornness of their heart, have heaped unto themselves; which despised the goodness,

* *Ps. cxix. 21.*
120.
Ps. vii. 11-13.
Ezek. xviii. 30.
Ps. li. 17.
Dan. ix. 4-6.

Matt. iii. 8, 10.
Marg.
Mat. iv. 1.

Hcb. x. 28, 31.
xii. 29.
* *Ps. xi. 7.*

Isa. xxvi. 21.

Mat. iii. 2, 3.
Matt. iii. 12. xiii.
30.

Ps. i. 4-6.
Isa. lxvi. 24.

1 Thess. v. 2, 3.
Matt. xxiv. 37-
39.
Luke xvii. 28-
30.

Rom. ii. 4, 5.
Matt. xxiv. 30.
Rev. vi. 16.
2 Pet. iii. 15, 9.

in recent times on any other day than Ash-Wednesday. The title has undergone three changes as follows:—

1549.	1552.	1661.
The First Day of Lent, commonly called Ash-Wednesday.	A Commination against sinners, with certain Prayers, to be used divers times in the year.	A Commination, or denouncing of God's anger and judgements against sinners, with certain prayers, to be used on the first day of Lent, and at other times, as the ordinary shall appoint.

The original title, it will be observed, agrees with the ancient one; and the alteration was made at the suggestion of Martin Bucer, whose Judaizing tendencies led him to wish for a more frequent use of the Commination, and a general revival of open penance, the infliction of which seems to have possessed great charms for Puritan minds. From some Visitation Articles of Bishop Grindal's [Cardwell's Docum. Annals, i. 398] it seems probable that it was used in some places "on one of the three Sundays next before Easter, one of the two Sundays next before the Feast of Pentecost, and one of the two Sundays next before the feast of the birth of our Lord." But such a signal perversion of the Sunday festival was not likely ever to have become general.

The introduction of the awful Judaic maledictions into the

patience, and long-sufferance of God, when he calleth them continually to repentance. Then shall they call upon me, (saith the Lord,) but I will not hear; they shall seek me early, but they shall not find me; and that, because they hated knowledge, and received not the fear of the Lord, but abhorred my counsel, and despised my correction. Then shall it be too late to knock when the door shall be shut; and too late to cry for mercy when it is the time of justice. O terrible voice of most just judgement, which shall be pronounced upon them, when it shall be said unto them, Go, ye cursed, into the fire everlasting, which is prepared for the devil and his angels. Therefore, brethren, take we heed betime, while the day of salvation lasteth; for the night cometh, when none can work. But let us, while we have the light, believe in the light, and walk as children of the light; that we be not cast into utter darkness, where is weeping and gnashing of teeth. Let us not abuse the goodness of God, who calleth us mercifully to amendment, and of his endless pity promiseth us forgiveness of that which is past, if with a perfect and true heart we return unto him. For though our sins be as red as scarlet, they shall be made white as snow; and though they be like purple, yet they shall be made white as wool. Turn ye (saith the Lord) from all your wickedness, and your sin shall not be your destruction:

Prov. i. 28-30.

Math. xxv. 10, 11.
 2 Cor. vi. 2.

Deut. vii. 21.

Math. xxv. 41.
 Heb. ii. 1-3, iii. 12.

2 Cor. vi. 2.
 Heb. xii. 25.

John ix. 4, 5.

Math. xxv. 30.

Rom. ii. 4.
 Isa. lxiii. 9.
 xlv. 22.
 lv. 7.

Isa. i. 18.

Ezek. xviii. 30-32.

Cast away from you all your ungodliness that ye have done: Make you new hearts, and a new spirit: Wherefore will ye die, O ye house of Israel, seeing that I have no pleasure in the death of him that dieth, saith the Lord God? Turn ye then, and ye shall live. Although we have sinned, yet have we an Advocate with the Father, Jesus Christ the righteous; and he is the propitiation for our sins. For he was wounded for our offences, and smitten for our wickedness. Let us therefore return unto him, who is the merciful receiver of all true penitent sinners; assuring ourselves that he is ready to receive us, and most willing to pardon us, if we come unto him with faithful repentance; if we submit ourselves unto him, and from henceforth walk in his ways; if we will take his easy yoke, and light burden upon us, to follow him in lowliness, patience, and charity, and be ordered by the governance of his Holy Spirit; seeking always his glory, and serving him duly in our vocation with thanksgiving: This if we do, Christ will deliver us from the curse of the law, and from the extreme malediction which shall light upon them that shall be set on the left hand; and he will set us on his right hand, and give us the gracious benediction of his Father, commanding us to take possession of his glorious kingdom: Unto which he vouchsafe to bring us all, for his infinite mercy. Amen.

Ps. li. 7, 10.

1 John ii. 1, 2.
 iii. 5. iv. 10

Isa. liii. 5, 6.
 Hosea vi. 1, xiv. 1, 2.
 Jer. iii. 12, 13.
 Mal. iii. 7.
 Luke xv. 18-20.
 John vi. 37.
 Isa. lv. 7.
 Ezek. xviii. 21, 22.

Math. xi. 29, 30.
 Eph. iv. 2.
 Heb. xii. 1.
 Col. iii. 14.
 1 Cor. vi. 20.
 x. 31.
 Gal. iii. 10.
 2 Thess. i. 7-9.

Math. xxv. 33, 34.
 xiii. 43.
 2 Pet. i. 8, 10, 11.
 * Ps. xliii. 5.

ancient service, and the archaic character of the homily, will probably always restrict its use to the first day of Lent. The form in which these are used is singularly out of character with the general tone of the Prayer Book; denunciation of sin ordinarily taking the form of a Litany, not of an exhortation, under the Christian dispensation. "These dangerous days" and other expressions also give the exhortations a tone which belongs to the past rather than the present.

It should be remembered, that the restoration of discipline which is spoken of in the second paragraph of the opening exhortation, does not refer to the ordinary discipline of the Church, but to the "godly discipline" of the "Primitive Church." Archdeacon Hale, in his volume of Precedents [page v of the Introductory Essay], illustrates this by a Canon enacted under King Edgar: "Hæ consuetudines trans mare observantur; id est, quod quilibet episcopus sit in sede episcopali sua die Mercurii, quem caput jejunii vocamus; tunc unusquisque eorum hominum qui capitalibus criminibus polluti sunt, in provincia ista, eo die

ad illum accedere debet, et peccata sua illi profiteri, et ille tum præscribit eis pœnitentiam, cuique pro ratione delicti sui; eos qui eo digni sunt, ab Ecclesiastica communitate segregat, et tamen ad propriam eorum necessitatem animat et hortatur; et ita postea, cum illius venia, domum redeunt." [Ancient Laws and Institutes of England, vol. ii., p. 267.] In the times to which this Canon belongs, the Episcopal exercise of this discipline resulted from the intimate admixture of the Ecclesiastical and Secular laws. In the Primitive Church a severity of discipline was gradually established (long after the Apostolic age), which was probably adopted with reference to a state of society in which self-control was rare, and gross vice unrebuked except by the Clergy. Persons* "convicted of notorious sin" are now otherwise punished; and an aspiration after the revival of an "open penance" which is utterly impossible, is apt to lead the thoughts away from the restoration of a discipline and penance which is both possible and desirable.

¶ Then shall they all kneel upon their knees, and the Priest and Clerks kneeling (in the place where they are accustomed to say the Litany) shall say this Psalm.

Miserere mei, Deus. Psalm li.

Lord, have mercy upon us.
Christ, have mercy upon us.
Lord, have mercy upon us.

OUR Father, which art in heaven, Hallowed be thy Name. Thy kingdom come. Thy will be done in earth, As it is in heaven. Give us this day our daily bread. And forgive us our trespasses, As we forgive them that trespass against us. And lead us not into temptation; But deliver us from evil. Amen.

Minister.

Ps. lxxxvi. 2. O Lord, save thy servants;

Answer.

That put their trust in thee.

Minister.

Ps. xx. 1, 2. Send unto them help from above.

Answer.

And evermore mightily defend them.

Minister.

Help us, O God our Saviour.

Answer.

Ps. lxxxix. 9. And for the glory of thy Name deliver us; be merciful to us sinners, for thy Name's sake.

Minister.

Ps. cii. 1. O Lord, hear our prayer.

Answer.

And let our cry come unto thee.

Minister.

Let us pray.

Ps. iv. 1.
Joel ii. 17.
Acts ii. 37.
Ps. xxxiv. 18.
Micah vii. 18.

OUR LORD, we beseech thee, mercifully hear our prayers, and spare all those who confess their sins unto thee; that they, whose consciences by sin are accused, by thy merciful pardon may be absolved; through Christ our Lord. Amen.

Ps. cxlv. 8, 9.
Matt. v. 45.
1 Tim. ii. 3, 4.
Ezek. xxxiii. 11.
2 Pet. iii. 9.
Heb. viii. 12.
Prov. xviii. 14.
Matt. xi. 28.
2 Thess. ii. 16, 17.
Exod. xxxiv. 6, 7.
Mark ii. 7.
Joel ii. 17.
Ps. cxliii. 2.

MOST mighty God, and merciful Father, who hast compassion upon all men, and hatest nothing that thou hast made; who wouldest not the death of a sinner, but that he should rather turn from his sin, and be saved; Mercifully forgive us our trespasses;

.... Deinde prosternant se clerici in choro, et Salisbury Use. dicant septem Psalmos penitenciales cum Gloria Patri et sicut erat et Antiphona ne reminiscaris.

* * * * *

Kyrie eleison.

Christe eleison.

Kyrie eleison.

PATER noster, qui es in cœlis; sanctificetur nomen tuum: adveniat regnum tuum: fiat voluntas tua, sicut in cœlo, et in terra. Panem nostrum quotidianum da nobis hodie: et dimitte nobis debita nostra, sicut et nos dimittimus debitoribus nostris: et ne nos inducas in tentationem: sed libera nos a malo. Amen.

Salvos fac servos tuos et ancillas tuas.

Deus meus sperantes in te.

Mitte eis, Domine, auxilium de sancto.

Et de Syon tuere eos.

Convertere, Domine, usquequo.

Et deprecabilis esto super servos tuos.

Adjuva nos, Deus, salutaris noster!

Et propter gloriam nominis tui, Domine, libera nos et propitius esto peccatis nostris propter nomen tuum.

Domine, exaudi orationem meam.

Et clamor meus ad te veniat.

Dominus vobiscum.

Oremus.

EXAUDI, quæsumus, Domine, preces nostras, et confitentium tibi parce peccatis: ut quos conscientia reatus accusat indulgentia tuæ miserationis absolvat. Per Christum.

OMNIPOTENS, sempiternæ Deus: Benedictio cinerum. Greg. Gelas. qui misereris omnium, et nihil odisti eorum quæ fecisti.

Oratio.

DOMINE Deus noster, qui offensione nostra non vinceris, sed satisfactione placaris: respice, quæsu-

Jer. xiv. 20.
Job xi. 4. xlii. 5,
6.
Ps. xxii. 19.
Rev. iii. 12.

receive and comfort us, who are grieved and wearied with the burden of our sins. Thy property is always to have mercy; to thee only it appertaineth to forgive sins. Spare us therefore, good Lord, spare thy people, whom thou hast redeemed; enter not into judgment with thy servants, who are vile earth, and miserable sinners; but so turn thine anger from us, who meekly acknowledge our vileness, and truly repent us of our faults, and so make haste to help us in this world, that we may ever live with thee in the world to come; through Jesus Christ our Lord. *Amen.*

¶ *Then shall the people say this that followeth, after the Minister,*

Lam. v. 21.
Joel ii. 12, 13.
Jer. i. 4.
Zech. xii. 10.
Ps. lxxi. 15.
Ezra ix. 13.
Hab. iii. 22.
Joel ii. 17.
Jer. xxix. 11.
Ps. cxix. 156.
ii. f.
John xiv. 6.
Gal. i. 3, 4.

TURN thou us, O good Lord, and so shall we be turned. Be favourable, O Lord, Be favourable to thy people, Who turn to thee in weeping, fasting, and praying. For thou art a merciful God, Full of compassion, Long-suffering, and of great pity. Thou sparest when we deserve punishment, And in thy wrath thinkest upon mercy. Spare thy people, good Lord, spare them, And let not thine heritage be brought to confusion. Hear us, O Lord, for thy mercy is great, And after the multitude of thy mercies look upon us; Through the merits and mediation of thy blessed Son, Jesus Christ our Lord. *Amen.*

¶ *Then the Minister alone shall say,*

Numb. vi. 24—
26.

THE Lord bless us, and keep us; the Lord lift up the light of his countenance upon us, and give us peace, now and for evermore. *Amen.*

mus, super famulos tuos qui se tibi graviter peccasse confitentur: tuum est enim absolutionem criminum dare, et veniam præstare peccantibus; qui dixisti pœnitentiam te malle peccatorum, quam mortem: concede, ergo, Domine, his famulis tuis, ut tibi pœnitentiæ excubias celebrent, et correctis actibus suis conferri sibi a te sempiterna gaudia gratulentur. Per Christum:

CONVERTIMINI ad me in toto corde vestro: in jejunio et fletu et planctu: Inter vestibulum et altare plorabunt sacerdotes ministri Domini, et dicent Parce, Domine, parce populo tuo: et ne des hæreditatem tuam in opprobrium.

Lectio Johelis
proph. ii. in
Missæ.

EXAUDI nos, Domine, quoniam magna est misericordia tua: secundum multitudinem miserationum tuarum respice nos, Domine.

Antiph. in
Bened. ciner.
Antiph. Greg
ibid.

“Thou that makest the outgoings of the morning and evening to praise Thee.” PSALM lxxv. 8.

“That all things must be fulfilled which were written in the Psalms, concerning Me.”
LUKE xxiv. 44.

“These things saith He that hath the Key of David.” REV. iii. 7.

“My soul shall be satisfied, even as it were with marrow and fatness : when my mouth praiseth
Thee with joyful lips.” PSALM lxxiii. 6.

AN

INTRODUCTION TO THE PSALTER.

§ 1. *The Manner of using the Psalms in Divine Service.*

WHETHER or not the Psalms were all primarily composed for use in Divine Service, it is certain that many of them were so; that all were collected together for that purpose by those who had charge of the services offered up to God in the Temple; and that they were taken into public devotional use by the early Christian Church after the example of the Jewish.

Psalms were composed and sung by Moses, Miriam, Deborah, and Hannah; but it may be reasonably supposed that the constant use of them in Divine Service originated with David, the "sweet singer of Israel," whose pre-eminence as an inspired Psalmist has caused the whole collection to be called after his name, "the Psalms of David." To him was assigned the work and honour of preparing the materials out of which the Temple was to be built; and to him also the honour of preparing the materials of that Divine Psalmody which was henceforth ever to mingle with the worship of Sacrifice, and form the substance of the praises offered to God throughout the world. It seems even as if the very earliest Liturgical use of Psalms was recorded in the statement, "Then on that day David delivered first *this psalm* to thank the Lord into the hand of Asaph and his brethren," on occasion of the ark of God being brought to its home of ages on Mount Zion [1 Chron. xvi. 7]. It is true that the words "this psalm" are not in the original, and that the psalm afterwards given is a cento of the 105th, the 96th, and other Psalms which are considered by modern critics to belong to a much later date than that indicated; but there can be no doubt that David had been inspired to compose some of his psalms long before, and that when "he appointed certain of the Levites to . . . thank and praise the Lord God of Israel . . . to give thanks to the Lord, because His mercy endureth for ever" [vv. 4, 41], he was initiating on Mount Zion that system of liturgical psalmody, which (even if it had existed in any form previously) was now to continue there until it was taken up by the Christian Church. The establishment of this system in the Temple is recorded with similar exactness in 2 Chron. vii. 6, "And the priests waited on their office: the Levites also with instruments of musick of the Lord, which David the king had made to praise the Lord, because His mercy endureth for ever, when David praised by their ministry." And in a previous chapter the advent of the Divine Presence is connected in a remarkable manner with the first offering of such praises in the Temple: "It came even to pass, as the trumpeters and singers were as one, to make one sound to be heard in praising and thanking the Lord; and when they lifted up their voice with the trumpets and cymbals and instruments of musick, and praised the Lord, saying, For He is good: for His mercy endureth for ever: that then the house was filled with a cloud, even the house of the Lord. So that the priests could not stand to minister by reason of the cloud; for

the glory of the Lord had filled the house of God" [2 Chron. v. 13, 14]. Thus in the dedication of the Temple, we see the final settlement of the system of praise originated (as it seems) by David at the triumphal entry of the ark of God to Mount Zion; and in "the Levites which were the singers, all of them of Asaph, of Heman, of Jeduthun, with their sons and their brethren, arrayed in white linen," we see the Jewish original of those strophed choirs by which the same Psalms of David have been sung in every age of the Christian Church.

The hundred and fifty Psalms of the Christian Psalter were, however, the growth of perhaps six centuries, extending from David to Ezra and Nehemiah; and hence only a portion of those we now sing were used in the Temple of Solomon, although all were so used in the four centuries which preceded the Advent of our Lord, and the supersession of the Jewish by the Christian Church. This gradual growth of the Psalter led to that division into five parts which is so evident in its structure, and which is also noticed by some of the Fathers who lived near to the time of its use in the Temple. Doxologies are found at the end of the 41st, 72nd, 89th, and 106th Psalms, and these are considered to point out the division of the Psalter into five books, partly according to the date of their composition, and partly with reference to some system of Liturgical use. But notwithstanding these divisions, there is an equally evident union of all the books into one by means of the first Psalm, which forms a general introduction or Antiphon, and the last which forms a general Doxology, to the whole number.

The mode in which the Psalter was used in the Services of the

1 Modern critics have analyzed the Book of Psalms with great minuteness. The general result of the conclusions arrived at by Hengstenberg, Mr. Thrupp, and others, may be shortly stated thus:

§ Table of the Authorship and Compilation of the Psalter, according to modern critics.

Books.	Psalms.	Authorship.	When, or by whom collected for use in the Temple.
I.	1-41	David.	David.
II.	42-49	The Levites.	In the time of Hezekiah.
	50	Azariah.	
III.	51-71	David or Solomon.	In the time of Josiah.
	72	David.	
	73-85	The Levites.	
IV.	86	Hezekiah.	Ezra or Nehemiah.
	87-89	The Levites.	
V.	90-106	Various writers, including Moses, the prophets, and Ezra.	
	107-150		

But the prophetic aspect of David's office as the chief of Psalmists seems to be too little regarded in the latter part of this classification; and probably many psalms were written by him—such as the "Songs of Degrees"—which are here assigned to later authors.

Primitive Church is not known, but it seems clear that the division into books was disregarded, and the whole Psalter treated as a collection of one hundred and fifty separate Psalms distinguished by titles and numbers; and it is hardly probable that any definite separation of these into diurnal or weekly portions was adopted in the earliest age of the Church. There has, in fact, always been a great variety in the mode of appropriating the Psalms to hours and days in all those times of which any such method is recorded, and this would not have been the case if any definite system had been originated in early times. We must, therefore, suppose that the Church was left quite at liberty in this respect, and that each Diocese or Province adopted or originated such a division of the Psalter for use in Divine Offices as was considered most expedient for the time in which it was to be used, and for the persons who were to use it.

The most ancient systems of the Psalter known to us are the Oriental, the Ambrosian, and the Mozarabic; all three of which are of so extremely complicated a character that it is hardly possible to give any clear notion of them without occupying many pages. Some account of them will be found in Neale's

Introduction to the History of the Holy Eastern Church, and in his Commentary on the Psalms; and Archdeacon Freeman has traced out some analogies between the Eastern and Western systems in his Principles of Divine Service; to which works the reader is referred for further information. In the Latin Church generally the Psalter was used according to the plan laid down by St. Gregory in the sixth century, and this was almost identical with the ordinary use of the English Church up to the time of the Reformation. The characteristics of this system will be seen in the annexed Table, which shows the manner in which the whole of the hundred and fifty Psalms were appointed to be sung in the course of every seven days. A general principle underlies the whole arrangement, viz., that of appropriating the first half of the Psalms to the earlier, and the second half to the later part of the day; but this general principle (for which there is no ground in the character of the Psalms themselves) is associated with a principle of selection, by which certain Psalms are set aside for particular hours, as the 51st for Ferial Lauds, the Compline Psalms, and the three last, which were appointed for constant use at Lauds, whether Ferial or Festival.

§ Table of the Ordinary Course in which the Psalms were appointed to be sung in the ancient Church of England.

Hours.	The Lord's Day.	Monday.	Tuesday.	Wednesday.	Thursday.	Friday.	The Sabbath.
Mattins { 1st Nocturn 2nd Nocturn 3rd Nocturn	1-3, 6-15, 16-18, 19-21.	27-38.	39-42, 44-50, 52.	53, 55-62, 64-66.	69-80.	81-89, 94, 96, 97.	98-109.
Lauds	93, 100 ¹ , 63, 67. Song of the Three Children. 148, 149, 150 ² .	51, 5, 63. Song of Isaiah (Isa. xii.). 148, 149, 150.	51, 43, 63. Song of Hezekiah (Isa. xxxviii.). 148, 149, 150.	51, 65, 63. Song of Hannah (1 Sam. ii.). 148, 149, 150.	51, 90, 63. Song of Moses (Exod. xv.). 148, 149, 150.	51, 143, 63. Song of Habakkuk (Hab. iii.). 148, 149, 150.	51, 92, 63. Song of Moses (Deut. xxxii.). 148, 149, 150.
Prime	22-28, 54, 118, 119, v. 1-32.	22-26, 54, 119, v. 1-32.					
Tierce	v. 33-80,		As on Monday.	As on Monday.	As on Monday.	As on Monday.	As on Monday.
Sexts	v. 81-128,						
Nones	v. 129-176.						
Vespers	110-115.	116, 117, 120, 121.	122-126.	127-131.	132, 133, 135- 137.	138-142.	144-147.
Compline	4, 31, v. 1-7, 91, 134.	As on Sunday.	As on Sunday.	As on Sunday.	As on Sunday.	As on Sunday.	As on Sunday.

This system was little more, however, than a paper system, as it was broken in upon by the frequent occurrence of Festivals; when the ordinary or Ferial Psalms were set aside: and Festivals were so numerous that, in practice, less than one-half of the Psalms, instead of the whole number, were sung through weekly; as is the case in the Latin Church at the present day³. This deviation from the appointed order is referred to in the Preface to the Prayer Book of 1549: "... notwithstanding that the ancient Fathers have divided the Psalms into seven portions, whereof every one was called a *Nocturn*: now of late time, a few of them have been daily said, and the rest utterly omitted." The weekly recitation of the Psalter, however beautiful in theory, was not, therefore, the real practice of the Church; although it was doubtless adopted by many devout persons in their private devotions.

There is reason to think that the ancient system was being set aside also in another way, before any attempt had been made to construct an English Prayer Book out of the ancient Offices. Psalters exist which bear on their title-page "*ad usum insignis ecclesiæ Sarum et Eboracensis*," in which a much more simple arrangement is adopted, and one out of which our modern use evidently took its rise. Fifteen such Psalters have been examined by the writer in the Bodleian Library, and in the British Museum, in all of which the Psalms are arranged in a numerical order, according to the following plan, instead of on the elaborate system shown in the preceding Table.

§ Table of the Ordinary Course appointed for the Psalms in Psalters of 1480-1516.

	Mattins.	Prime.	Tierce ⁴ .	Sexts.	Nones.	Vespers.
Sunday ...	1-26					110-115
Monday ..	27-38	On Ferial days the 119th Psalm is divided among these four hours, and at Nones, 120th and 121st are added to the portion appointed for that hour.				116-118
Tuesday ..	39-52					122-126
Wednesday	53-68					127-131
Thursday ..	69-80					132-137
Friday....	81-97					138-143
Saturday..	98-109					144-150

In this plan all the Psalms except the 119th and the two short ones following it are divided between Mattins and Vespers, and no notice is taken of Compline; the proportion assigned to Mattins being more than four times that assigned to Vespers, and more than ten times that given to the four intermediate hours⁵.

⁴ In King Edward VI.'s Injunctions of 1547 there is one to this effect: "*Item*, when any Sermon or Homily shall be had, the Prime and hours shall be omitted." This omission seems to have represented a much earlier practice, as there are no Psalms provided for the little hours of Sunday in the above arrangement of the Psalter. See also the 4th of the Injunctions at page xxv.

⁵ The Psalters examined are as follows: Bodleian Library, Douce, 9 (1480), 70 (1504); A. 2, 18. Linc. (1506), Douce, 26, 141; C. 4, 10, Linc. (all 1516); Douce 8 (1530); Rawl. 990 (n. d.); C. 42, Linc. (1555). British Museum Library, Harl. MSS., 2856, 2838, C. 35, g. (1516); C. 35, b. (1524); C. 35, a. (1529). It is quite evident that some of these Psalters were intended for use in the choir; and this is expressly stated in the title of the sixth (Douce, 8), dated 1530, which is as follows: "*Psalterium ad decantanda in choro officia ecclesiastica accommodatissimum cum sexpartita litanis, hymnis quoque, ac vigiliis defunctorum, una cum calendario et tabulis ex diversis*

¹ In Lent Psalms 51 and 118 were used instead of 93 and 100.

² These eight Psalms were also those of Lauds on all Feasts of Saints.

³ The abuse has even increased in modern times, and Mr. Neale says that "according to the practice of the modern Roman Church, a Priest is in the habit of reciting about fifty Psalms, and no more; these fifty being, on the whole, the shortest of the Psalter." Comm. on Psalms, p. 20.

How far this new plan of reciting the Psalter was introduced into the Church of England it is impossible to say; but it is plainly a link of transition between the ancient system, adapted for the Clergy and religious bodies, and the modern one, adapted for parochial use. It is far from improbable that it was introduced with a view to parochial use; and that for the private recitation of the Clergy and the use of monastic bodies the old system was still retained. The arrangement of the Psalter made by Cardinal Quignonez in his Reformed Breviary had no influence whatever on that adopted in the Prayer Book. The latter was settled in 1549, and has never since been altered. If we could read the experience of previous ages, as well as we can those of the times that have elapsed since this monthly system of recitation was introduced, we should probably come to the conclusion that it is the best one that could be adopted for general use, according to the ordinary measure of devotional attention of which ordinary persons are capable.

Three principal ways of singing or saying the Psalms have been generally recognized in the Christian Church, (1) The Cantus Directus, in which the whole Psalm is sung straight through by the whole choir. (2) The Cantus Antiphonalis, in which the Choir is divided into two sides, the Cantoris and Decani, each singing alternate verses. (3) The Cantus Responsarius, in which the Precentor sings the verses with uneven numbers, and the Choir or Congregation those with even numbers. All three methods have always been in use in the Church of England, but the second and third most commonly so; and all three have the sanction of ancient custom. The second is the method which the Christian Church inherited directly from the Jewish, the one which is most in accordance with the heavenly pattern of praise revealed to us through Isaiah and St. John; and the third may be looked upon rather as a modification of it than as a separate system.

§ 2. Versions of the Psalter used in Divine Service.

It is not probable that the Psalms were ever sung in Hebrew in the Christian Church, although they were doubtless so used in the Temple to the last. Our Lord and His Apostles sanctioned their use in the Vernacular by frequently quoting them from the Septuagint Version; and it is from that Version they are principally quoted even in the Epistle to the Hebrews¹. The instinct of the Church which has always made it cling to the Septuagint Psalms for use in Divine Service may, therefore, be regarded as growing out of its most primitive usages; and, in some degree, out of our Blessed Lord's own example.

But although a Greek Psalter was thus ready to hand for the Church to use in its services at their first institution, a Latin version was almost equally necessary for that large portion of the western world, in which the Septuagint Psalms would have been almost as unintelligible as the Hebrew. How soon, or by whom, this Latin translation of the Psalter was made, is not on record. Probably it was made at the same time that other portions of Holy Scripture were translated; although it seems almost impossible but that it should have preceded the writing down of the Gospels in Greek, since otherwise the Psalmody of Divine Worship would have been unintelligible to large numbers of Latin Christians.

Portions of such a primitive Latin version of the Holy Scriptures, and more especially the Psalms, are still extant in the works of the Latin fathers who preceded St. Jerome, and in

orthodoxorum practicus patrum collectis: ad simplicium sacerdotum clericorumque instructionem nunc quidem impressum: et a quodam erudito castigatum et auctum. 1530. Venundantur Londonii in cimiterio divi Pauli apud Johannem renis sub intersignio Sancti Georgii."

The same arrangement of the Psalter is also found in an Augsburg Psalter in the Bodleian [Douce, 268], and in a Psalter in the British Museum, which is marked "in usum ecclie Augusten" in the Catalogue. The Bodleian copy begins, "In nomine Dni nostri Jhesu xri amen. Incipit psalterium cum suis penitentibus quemadmodum ecclesie Augusten ordinatum Dominicis diebus. Invitatorium. Adoremus dominum qui fecit nos."

¹ Tertullian, in his Apology (c. xviii.), seems to say that the Jews of Egypt used the LXX in their Synagogues.

ancient Psalters. The Psalms were so generally used in private as well as for Divine Worship, that St. Augustine says every one who knew a little of Greek as well as Latin was accustomed to dabble in the work of translation. But there appears to have been one principal and recognized Latin Version of the whole Bible, of very early date, which was called the Italic version by St. Augustine [De Doct. Christ. ii. 15]; and to which St. Jerome gave the name of the Vulgate, a name afterwards applied to his own translation. Of this ancient Vulgate, or "old Italic," the Psalter is still extant (although, perhaps, with some corrections of a later date), and it was used in Divine Service long after the rest of the translation had been superseded by the labours of St. Jerome. This version is substantially indicated by the marginal variations which are printed on the right hand in the following pages.

St. Jerome left three versions of the Psalter, which have acquired the names of the Roman, the Gallican, and the Hebrew. The latter was so called, because it was translated directly from the original; but it has never been used in Divine Service, and has rarely appeared in volumes of the Holy Scriptures, and need not, therefore, be further mentioned here. The Roman Psalter of St. Jerome is simply the old Italic sparingly corrected by him, at the request of St. Damasus, during his residence at Rome about A.D. 383. This version was used in the churches of the city of Rome down to the sixteenth century, and is even still used in the church of the Vatican and in St. Mark's at Venice; but it was never extensively used in Divine Service; and where it is found in Psalters meant for use in Divine Service, the older version is mostly written in a parallel column or interlineated, showing the hold which it retained upon the affections of the Church². The Gallican version of St. Jerome has, on the other hand, been the Psalter of the whole Western Church for many centuries, although it was a long time before it entirely superseded the ancient Italic, or Vetus Vulgata. It was translated from Origen's edition of the Septuagint by St. Jerome while he was living at Bethlehem, A.D. 389, and was introduced into Germany and Gaul either by St. Gregory of Tours in the end of the sixth century, or by the English Apostle of Germany, St. Boniface, in the early part of the eighth century. From France it was brought over to England, and eventually superseded the older Italic version in Divine Service throughout the Church of England on the revision of its offices by St. Osmund in the twelfth century. The same version (slightly altered at the last revision of the Vulgate) is in use throughout the Latin Church, both in Divine Service and in complete volumes of the Holy Bible.

Our English Psalter grew out of this long used "Psalterium Davidicum ad usum Ecclesie Sarisburiensis," that is, out of the Gallican version of St. Jerome. It was frequently translated into Anglo-Saxon and mediæval English; and the fifty-two Psalms of the Prymer were of course so translated and revised at the various periods at which the Prymer was re-edited. The English Old Testament which Wickliffe prefixed to his translation of the New Testament, was doubtless (like the latter) translated almost entirely from the familiar Latin Bible; and the Psalms of this version (in common with other books of Scripture) formed the basis of subsequent translations. Thus, when it was found necessary to restrain the growth of private English versions of the Bible, and to issue one standard and authorized edition, which was in 1540, the edition so issued was a gradual growth, springing originally from the Latin Vulgate of St. Jerome, and corrected (after his example) by comparison with the Septuagint Version and the Hebrew original.

From this first authorized edition of the English Bible our Prayer Book Psalms are taken, as is stated in a note which follows the Preface to the Prayer Book, respecting the Order in which the Psalter is appointed to be read³. The paragraph

² The same thing is found in some Bibles of Queen Elizabeth's reign, in which the old version is placed side by side with that of 1568. In some, the old version supersedes the authorized one altogether.

³ The "Bible version" of the Psalms has gone through two subsequent revisions, the first that of Archbishop Parker in 1568, and the last that of

referred to is as follows:—"Note, That the Psalter followeth the Division of the Hebrews, and the Translation of the Great English Bible, set forth and used in the time of King *Henry the Eighth* and *Edward the Sixth*." The only change made since 1540 has been the numbering of the verses, which was first done in the Latin Prayer Book of 1572, and then in the English of 1620.

Thus the English Psalter, which we now use in Divine Service, may be said to speak the continuous and enduring language of the Church, after the example of our Lord and His Apostles when they spoke truths out of Holy Scripture not in the original Hebrew language, but in the venerable Greek version of the Septuagint. And the peculiar manner in which the English Psalter has grown out of the Psalters of ancient days, may entitle us to say, without extravagance or irreverence, that it represents, by a sort of Catholic condensation into one modern tongue, the three ecclesiastical languages in which the Psalter has chiefly been used, the "Hebrew, Greek, and Latin" of the Cross; and that it thus represents also the original and the continuous Inspiration by which God the Holy Spirit guides the Church into all truth.

§ 3. *The Meaning of the Psalms as used in Divine Service.*

No part of Holy Scripture possesses greater capacity than the Psalter for that many-sided application which is a chief characteristic of inspired writings. We may regard it as a book of history, for it contains a large store of materials for filling up the details of the personal life of David and of the national life of Israel. It is a book of spiritual experiences; for in it the man after God's own heart, and other godly souls, have recorded the love, the joy, the penitence, the sorrow with which they opened out their innermost selves to their God. If we look for moral teaching there, we may hear God Himself speaking to us precepts of Divine wisdom through His servants, showing what are His ways towards men, and what the relation in which they stand to Him. If we ask for words of prayer, in the Psalter we find the very Prayer Book which was used by Christ and His saints; and may use the privilege of sending up to the Throne of Grace the very aspirations that have been consecrated a second time by passing thither from the lips of the Son of Man. From one end to the other it is full of the praises of the Lord, such as the soul need never tire of uttering, and the Lord will never tire of receiving. It is a book of prophecy, speaking of things that were to be in distant ages with words that show how deeply they were inspired by Him to Whom all things are a continual present. And it is, above all, a book in which Christ and His Church are prefigured, so that David speaks in the Person of his Lord, and Israel personifies that new Jerusalem which is the Mother of us all.

Of these manifold tones in which the Psalter speaks, some are adapted for the pulpit, some for private meditation, some for the confession of the penitent when he is upon his knees in self-abasement. But when it is used in Divine Service there is one tone with which the Psalter ever rings; and that is the one which speaks to the praise and glory of God concerning the relations which exist between the Divine Nature, the Son of Man, and the Mystical Body of Christ. All other aspects in which the Psalter can be viewed ought to come within the range of Christian study and practice; and we cannot afford to undervalue any one of them. But as a Psalter for use in Divine Service all other views and meanings ought to be subordinated to this, which sees chiefly God, and Christ, and the Church in the Psalms. Thus the Christian finds the Psalter a living word for every generation; and if he sings concerning the City of God, the voice of his understanding and love dwells little on the historical Jerusalem of the past, but soars upward either to the allegory under

which lies hidden the Church Militant of the present, to the figurative representation of the soul in which Christ dwells, or to the exalted Image which reveals to his faith that Celestial City, wherein will be the eternal home of the saints¹.

This spiritual mode of viewing the Psalms was the principal if not the only one adopted by the early Church. "All the Psalms," says St. Jerome, "appertain to the Person of Christ." "David more than all the rest of the prophets," says St. Ambrose, "spoke of the marriage between the Divine and Human nature." Tertullian had declared that nearly all the Psalms represent the Son speaking to the Father; and St. Hilary leaves his opinion on record, that all which is in the Psalms refers to the knowledge of the coming of our Lord Jesus Christ, His Incarnation, Passion, and Resurrection, and to the glory also and power of our own life in Him. Such habits of thought were partly inherited from the Jews, who could see the Messiah in their ancient prophecies, though the generation in which He came failed to recognize His actual Person. But without going back to the Jews, we may trace this clear vision of Christ in the Psalms to the Apostles themselves, and from them to the teaching of His own lips and example. In the earliest dawn of the Church after the Ascension, the Apostles began to find in the Psalms an explanation of the events which were occurring around them. They recognized in the fall of an Apostle a fulfilment of that "which the Holy Ghost by the mouth of David spake before concerning Judas which was guide to them that took Jesus For it is written in the book of Psalms, Let his habitation be desolate, and let no man dwell therein; and his bishoprick let another take" [Acts ii. 16. 20]. And in the Resurrection of their Lord they found the one full interpretation of what the "patriarch David being a prophet" and "seeing before" of that which was to be, "spake of the Resurrection of Christ, that His soul was not left in hell, neither His flesh did see corruption" [Acts ii. 31]. Such a use of the Psalms was not by way of adaptation or mere illustration, but as clear, unimpeachable evidence; infallible truth, coming from the Fountain of Truth.

Nor is it to be wondered at that the Apostles should thus immediately, and as a matter of course, go to the Psalms for light about Christ and the Church; for their Divine Master had often shown them the way during the time of His ministrations among them; while the last hours which He and they had spent together seem to have been wonderfully connected by Him with "the things that were spoken in the Psalms concerning Him." It seems, indeed, as if our Blessed Lord took every opportunity at that time of showing how the meaning of the Psalter was to be seen clearly only when viewed in the light of the Gospel. When the Pharisees remonstrated with Him for permitting the children to sing Hosanna to Him as the Son of David coming in the Name of the Lord, it is out of David that He answers them, reminding them of the eighth Psalm, and saying, "Yea, have ye never read, Out of the mouth of babes and sucklings, Thou hast perfected praise?" [Matt. xxi. 16.] In the same manner, shortly after, He foretold them of His own glory (notwithstanding their rejection of Him) by quoting words that seemed from a human point of view to have had no such application, "The stone which the builders rejected is become the head of the corner" [Matt. xxi. 42]. And from their own confession that Christ was the Son of David spoken of in the Psalms, He convicted them of folly in not acknowledging Him, the Son of David, for their Lord [Matt. xxii. 45].

After these final hours of Christ's public ministrations came those which ended the time of His humiliation. When, during that sad and solemn period, He would reveal to the Apostles that the traitor was to come from among themselves, He shows them how this had been already predicted in the Psalms, and that what is to happen will be in fulfilment of the Scripture, "He that eateth bread with Me hath lifted up his heel against Me"

the translators (principally the Cambridge Committee) of 1611. But the Commissioners of 1611 were specially enjoined to deviate from Archbishop Parker's version of 1568 only when the sense of the original positively required them to do so, and "revision" would more truly describe their work than "translation."

¹ These four meanings of Holy Scripture are thus expressed in an ancient couplet:

"Littera scripta docet: quod credas Allegoria:
Quid speres, Anagoge: quid agas, Tropologia."

[John xiii. 18]: When He speaks of the feelings which the Jews entertained towards Him, again He goes to the Psalms, "But this cometh to pass that the word might be fulfilled that is written in their law, They hated Me without a cause" [John xv. 25]. His last act of common worship with them was when He and they sung the latter half of the great Hallelujah hymn of the Passover [Psalms 116—118] as they went forth to Gethsemane. And when He was on the Cross the words of the Psalmist form such an atmosphere of fulfilled prophecy around the Throne of His suffering, as to make a thoughtful Christian receive with respect the old tradition, that He recited the twenty-second and following Psalms as far as the sixth verse of the thirty-first, before commending His soul into the hands of His Father, not in new words, but in those with which His Spirit had inspired David many ages before. [Luke xxiii. 46.]

When the Apostles, then, began immediately to look for the Gospel in the Psalter, they followed with loving faith in the path which their Master had opened out to them by His words and example. And that this pathway was not opened out for a temporary object, only as one by which the Jews might be led through their own Scriptures to conviction, may be seen by the frequency with which St. Paul (who received his Gospel by direct revelation from his ascended Lord, and chiefly for ministrations among those who were not Jews) deals with the Psalms in the same manner. He writes to the Romans concerning the privileges which Christ brought home to Gentiles as well as Jews, and finds God's olden declaration of this truth in the words of the 18th Psalm, "For this cause I will confess to Thee among the Gentiles, and sing unto Thy Name;" and again in the 117th Psalm, "Praise the Lord, all ye Gentiles; and laud Him, all ye people" [Rom. xv. 9. 11]. Where we should otherwise least expect it he finds an allegorical allusion to the first spread of the Gospel; and fixes the nineteenth as one of our Easter Psalms by showing that "their sound went into all the earth, and their words unto the ends of the world," refers to the Apostles of the Sun of righteousness, Who Himself, and Himself in them, was running His course to extend the Light of salvation through all nations. How remarkably the Apostle draws out the depth of meaning contained in the Psalms to throw light on the argument of his Epistle to the Hebrews, is familiar to every thoughtful reader of the New Testament; and some notes will be found under several Psalms in the following pages, connected with the meaning which he has given to them in that Epistle.

This principle of interpretation has been adopted by the Church in the selection of Proper Psalms for days which commemorate special epochs of our Lord's life and work; and a careful consideration of these Proper Psalms will show that the principle is recognized as one whose application is by no means intended to be limited to the most self-evident allegories and

spiritual interpretations. In the choice of such Psalms as the 19th, 89th, and 132nd for Christmas Day, of the 40th and 88th for Good Friday, of those appointed for Ascension Day, and of the 68th, 104th, and 145th for Whitsunday, we see the Church penetrating far below the surface into the mystical depths of the Psalter; and finding there reasons why these rather than other Psalms should be taken on the lips of Christians to celebrate the Incarnation, Death, and Ascension of our Lord, and the marvellous operations of the Holy Spirit in carrying on the work of God's glory in man's redemption.

There can be no doubt, therefore, that in thus using the Psalter as a treasury of truths respecting Christ and His Church, which God the Holy Ghost Himself has filled from the treasury of Divine wisdom, we are strictly following the course which our Lord and His Apostles first pointed out. And when, offering up to God of that which He has given us, we take these truths out of this treasury, and cause them to ascend to the Throne of His grace as the chief meaning of our words of praise, we make such a use of them as is most accordant with the habits of the saints, and with the teaching of our infallible Guide. Thus we praise Christ as God whose Throne is from everlasting; Christ who comes in the Incarnation, saying, "A Body hast Thou prepared Me;" Christ, the Stone set at nought by the builders, but becoming the Head of the corner; Christ bearing the sins of the world, and saying, as the Representative of sinners, "Lord, rebuke Me not in Thine indignation;" Christ, under the eclipse of sin borne for others, crying, "My God, My God, why hast Thou forsaken Me?" Christ, reigning from His Cross, lifted up that He may draw all men unto Him; Christ, awaking right early on the morning of the Resurrection; Christ, the King of Glory, carrying our nature within the everlasting gates; Christ, sitting on the right hand of God until all His enemies be made His footstool; Christ, the true Vine of Unity and Sacramental life, brought out of Egypt that it might take root, and fill the land with a people wondrously made one with Christ Himself.

Nor need we fear, even beyond those many applications of the Psalms in this manner which are given us in the New Testament, to seek for others also in uninspired wisdom and Christian common sense: especially if we take for our guides the many holy and learned writers who have striven humbly, reverently, and with deep faith to follow the line so clearly marked out for them, and to search the Psalms for Him that hath the Key of David that they might make an acceptable offering of praise in their worship before the Ark. Such a use of the Psalter will give to those who sing it day by day, some experience of the devout and happy feelings which David himself had, when he sang, "My soul shall be satisfied, even as it were with marrow and fatness: when my mouth praiseth Thee with joyful lips."

THE
PSALMS OF DAVID.

THE I. PSALM.

Beatus vir; qui non abiit.

The I. Day.
Morning
Prayer.

BLESSED is the man that hath not walked in the counsel of the ungodly, nor stood in the way of sinners : and hath not sat in the seat of the scornful.

2 But his delight is in the law of the Lord : and in his law will he exercise himself day and night.

Jer. xvii. 8.
Rev. xxii. 2.

3 And he shall be like a tree planted by the water-side : that will bring forth his fruit in due season.

4 His leaf also shall not wither : and look, whatsoever he doeth, it shall prosper.

5 As for the ungodly, it is not so with them : but they are like the chaff, which the wind scattereth away from the face of the earth.

6 Therefore the ungodly shall not be able to stand in the judgement : neither the sinners in the congregation of the righteous.

7 But the Lord knoweth the way of the righteous : and the way of the ungodly shall perish.

PSALTERIUM DAVIDICUM

AD USUM

ECCLESIAE SARISBURIENSIS¹.

PSALMUS I.

BEATUS vir qui non abiit in consilio impiorum, et in via peccatorum non stetit : et in cathedra penitentiae non sedit :

Sunday Mattins.
1st Noct.
Easter Day and
Eve, Mattins.

Sed in lege Domini voluntas ejus : et in lege ejus* meditabitur die ac nocte.

Et erit tanquam lignum, quod plantatum est secus decursus aquarum : quod fructum suum dabit in tempore suo :

Et folium ejus non defluet : et omnia quaecunque faciet prosperabuntur.

Non sic impii, non sic : sed tanquam pulvis quem projicit ventus a facie terrae.

Ideo non resurgent impii in judicio : neque peccatores in concilio justorum.

Quoniam novit Dominus viam justorum : et iter impiorum peribit.

PSALM I.

Beyond the obvious moral meaning of this Psalm, it contains a prophetic laudation of the holiness of Christ. He is "the Man" to Whom we sing, "Blessing, and glory, and wisdom, and thanksgiving, and honour, and power, and might," as the Lamb of God, Who is God, throughout the Psalms. In this particular Psalm He is praised as the one only wearer of our nature in Whom pure and perfect holiness has been found during the time of earthly sojourn and probation. In His temptation, He walked not in the counsel of the Wicked One, stood not in the way of sinners by yielding thereto, and refused the temporal *cathedra* which was offered Him (though it seemed to bring Him in a moment that sovereignty which could otherwise only be won through suffering), because it was the throne of the Evil One, the Prince of this world, and not the throne of the Cross. His delight was to do the will of Him that sent Him, in the day while there was glad sunshine and time to work, and in the night too, when all was eclipse, and darkness, and sorrow. Being

made perfect through suffering, He became the origin of perfection in others ; the Corn of Wheat cast into the ground to die and to spring up again with a power of life-giving in its own resurrection ; the Corn and Wine of the Tree of Life, planted by that River the streams whereof make glad the City of God ; a fruit of sacramental life, for the regeneration, edification, and resurrection of souls. Nor can any of His work fail through any deficiency of its own ; for whatsoever He doeth, whether of grace towards men, or of Intercession towards God, it shall prosper, because it is His.

As for the ungodly who sets up his kingdom against that of Christ, opposing Him first by the Jews, then by the Heathen, and at all times by sin, the end will prove how great the contrast ! The Wind of Pentecost will at last scatter altogether all the opponents of the Kingdom of God, as it has been doing in

¹ N.B.—Only the text of the Psalms themselves is here printed, notwithstanding the above title : and they are placed in the order of the modern, not of the ancient Psalter.

THE II PSALM.

Quare fremuerunt gentes ?

The I. Day.
Morning
Prayer.
Easter Day Mat-
tins.
A Passion Psalm.
Acts iv. 25.

WHY do the heathen so furiously rage together : and why do the people imagine a vain thing ?

2 The kings of the earth stand up, and the rulers take counsel together : against the Lord, and against his Anointed.

Luke xix. 14. 3 Let us break their bonds asunder : and cast away their cords from us.

4 He that dwelleth in heaven, shall laugh them to scorn : the Lord shall have them in derision.

5 Then shall he speak unto them in his wrath : and vex them in his sore displeasure.

6 Yet have I set my King : upon my holy hill of Sion.

Acts xiii. 33.
Cl. Matt. xxvi.
63.
Heb. i. 5. v. 5.

7 I will preach the law, whereof the Lord hath said unto me : Thou art my Son, this day have I begotten thee.

8 Desire of me, and I shall give thee the heathen for thine inheritance : and the utmost parts of the earth for thy possession.

Rev. ii. 27. xix.
15.

9 Thou shalt bruise them with a rod of iron : and break them in pieces like a potter's vessel.

10 Be wise now therefore, O ye kings : be learned, ye that are judges of the earth.

11 Serve the Lord in fear : and rejoice unto him with reverence.

John v. 23.

12 Kiss the Son, lest he be angry, and so ye perish from the right way : if his wrath be kindled (yea, but a little) blessed are all they that put their trust in him.

PSALMUS II.

QUARE fremuerunt gentes : et populi meditati sunt inania ? Sunday Mattins.
1st Noct.

Astiterunt reges terræ, et principes convenerunt in unum : adversus Dominum, et adversus Christum ejus.

Dirumpamus vincula eorum : et projiciamus a nobis jugum ipsorum.

Qui habitat in cælis irridebit eos : et Dominus subsannabit eos.

Tunc loquetur ad eos in ira sua : et in furore suo conturbabit eos.

Ego autem constitutus sum Rex ab eo super Sion montem sanctum ejus : prædicans præceptum ejus.

Dominus dixit ad me, Filius meus es tu : ego hodie genui te.

Postula a me, et dabò tibi gentes hæreditatem tuam : et possessionem tuam terminos terræ.

Reges eos in virga ferrea : et tan- Πολλὰ αὐτῶν,
LXX.
quam vas figuli confringes eos.

Et nunc reges intelligite : erudi- erud. omnes qui.
mini qui judicatis terram.

Servite Domino in timore : et exultate ei cum tremore.

Apprehendite disciplinam, nequando irascatur Dominus : et pereatis de via justa.

Cum exarserit in brevi ira ejus : beati omnes qui confidunt in eo.

part ever since its first sound was heard. For them there will be no defence in the dreadful Day of Judgment, nor any place in the Communion of glorified saints. Only the path which He has marked out, Who said, "I am the way," can lead to the Presence of God ; and they who go in the path of the Adversary must take their lot with him.

Blessed is the follower of the Man Christ Jesus, who walks in His way, and endureth temptation with stedfastness ; for after his trial and victory he also shall receive a crown of life, which the Lord Jesus, the righteous Judge, hath prepared for them that love Him, that they may reign with Him in His glory.

PSALM II.

This is a Hymn, at once, of our Lord's suffering and of His victory, and therefore a Psalm for Easter Day. Its true meaning is shown by the quotations from it in Acts iv. 25, 26, by SS. Peter and John, and by those in Acts xiii. 33, Heb. i. 5, and v.

5, by St. Paul. The manner in which it is quoted by the former may lead to the conclusion, however, that the Psalm is spoken of the mystical body of Christ, as well as of the Messiah Himself ; and of the Church also it may, indeed, be sung that she gained her victory over the world by suffering.

To this day the question may be asked, Why did the "heathen," and "the people" of the Jews, persecute Christ and His Church as they did ? "We will not have this Man to reign over us," was their cry for ages, as it is of the Jews still ; and yet God's irresistible law had gone forth that His eternally begotten Son should establish a supreme spiritual Empire upon earth, which should gather within its embrace all nations, to make them "the Kingdoms of the Lord and of His Christ." And now the Good Shepherd has broken asunder all other universal empire, that He might guide and gather men with His staff into the unity of His fold. While the world cries to break away the bands and to cast away the yokes, He is ever crying, "Take

THE III PSALM.

Domine, quid multiplicati?

The I. Day.
Morning Prayer.
[A daily Morning
Psalm of the
Eastern
Church.]
Matt. xvii. 43.
Isa. liii. 4.

LORD, how are they increased that trouble me : many are they that rise against me.

2 Many one there be that say of my soul : There is no help for him in his God.

3 But thou, O Lord, art my defender : thou art my worship, and the lifter up of my head.

4 I did call upon the Lord with my voice : and he heard me out of his holy hill.

John xii. 11.
1 Thess. iv. 14.

5 I laid me down and slept, and rose up again : for the Lord sustained me.

Matt. xvi. 53.

6 I will not be afraid for ten thousands of the people : that have set themselves against me round about.

7 Up Lord, and help me, O my God : for thou smitest all mine enemies upon the cheek-bone ; thou hast broken the teeth of the ungodly.

Acts iv. 12.

8 Salvation belongeth unto the Lord : and thy blessing is upon thy people.

THE IV PSALM.

Cum invocarem.

John xii. 27, 28.

HEAR me when I call, O God of my righteousness : thou hast set me at liberty when I was in trouble ; have mercy upon me, and hearken unto my prayer.

PSALMUS III.

DOMINE, quid multiplicati sunt qui tribulant me? multi insurgunt adversum me. Sunday Mattins.
1st Noct.

Multi dicunt animæ meæ: Non est salus ipsi in Deo ejus.

Tu autem, Domine, susceptor meus es: gloria mea, et exaltans caput meum.

Voce mea ad Dominum clamavi: et exaudivit me de monte sancto suo.

Ego dormivi, et soporatus sum: et exurrexi, quia Dominus suscepit me. et somnum capsi et
resurrexi quoniam...

Non timebo millia populi circumdantis me: exsurge, Domine, salvum me fac, Deus meus.

Quoniam tu percussisti omnes adversantes mihi sine causa: dentes peccatorum contrivisti. contrivisti

Domini est salus: et super populum tuum benedictio tua.

PSALMUS IV.

CUM invocarem exaudivit me Deus justitiæ meæ: in tribulatione dilatasti mihi. Compline.
invoc. te exaudisti
me

Miserere mei: et exaudi orationem meam. Miser. mihi, Domine, et

My yoke upon you . . . for My yoke is easy and My burden is light:" and the vengeance of the Lord has been displayed in that loving compulsion by which He has led His enemies to true wisdom and learning, by leading them to do reverent service and homage to the Son of Man.

Thus the Cross of the Passion has become the triumphant Banner of the Resurrection; and the sign of the Son of Man, which was once the badge of shame, surmounts the proudest tokens of earthly glory, to signify that He against whom the world exalted itself in vain, has become "King of kings and Lord of lords."

PSALM III.

In David, persecuted by his son Absalom, the light of Gospel analogy shows us a type of Christ coming to His own and His own receiving Him not. On Palm Sunday the multitude led Him in triumph to Jerusalem, but on Good Friday they led Him before Herod and Pilate; so that they were "increased" that troubled Him by rejecting Him, and become "many" that rose against Him, "saying, Crucify Him, Crucify Him." Literally, the mockers said, "He trusted in God; let Him deliver Him now, if He will have Him:" figuratively, the whole world looked on His Passion and said, "We did esteem Him stricken, smitten of God, and afflicted."

But, as in the preceding Psalm, the voice of sorrow is turned into a song of joy; and in the depths of His Passion, the suffering Man of Sorrows could say, "Father, into Thy hands I commend My spirit," knowing that He would be the Lifter up of His head in the Resurrection and in the coming Kingdom.

So may the Church take up the words of Christ, and set aside all fear when the world opposes the work of God, knowing that One has said, "The gates of hell shall not prevail against it."

So may each member of Christ lay them down to rest night by night, knowing that there is One who will "lighten our darkness;" and at the last lay them down to the sleep of the grave, saying, "I know that My Redeemer liveth,"—"If we believe that Jesus died and rose again, even so them also that sleep in Jesus will God bring with Him."

PSALM IV.

It is the last verse, probably, of this Psalm which has marked it out as the first of the Compline or late Evensong Psalms throughout the Eastern and the Western Church; but a general tone of thankfulness for rest after trouble, toil, and sorrow, pervades the whole Psalm, and fits it for the place which it has so universally occupied in the devotions of the Church.

Uttered in the person of Christ, it is an expansion of His com-

The 1. Day.
Morning
Prayer.
John viii. 49.

2 O ye sons of men, how long will ye blaspheme mine honour : and have such pleasure in vanity, and seek after leasing ?

Matt. iii. 17.

3 Know this also, that the Lord hath chosen to himself the man that is godly : when I call upon the Lord, he will hear me.

Eph. iv. 26.

4 Stand in awe, and sin not : commune with your own heart, and in your chamber, and be still.

5 Offer the sacrifice of righteousness : and put your trust in the Lord.

6 There be many that say : Who will shew us any good ?

7 Lord, lift thou up : the light of thy countenance upon us.

8 Thou hast put gladness in my heart : since the time that their corn and wine and oil increased.

9 I will lay me down in peace, and take my rest : for it is thou, Lord, only that makest me dwell in safety.

THE V PSALM.

Verba mea auribus.

PONDER my words, O Lord : consider my meditation.

John xx. 28.

2 O hearken thou unto the voice of my calling, my King, and my God : for unto thee will I make my prayer.

3 My voice shalt thou hear betimes, O Lord : early in the morning will I direct my prayer unto thee, and will look up.

4 For thou art the God that hast no pleasure in wickedness : neither shall any evil dwell with thee.

5 Such as be foolish shall not stand in thy sight : for thou hatest all them that work vanity.

Filii hominum, usquequogravi corde? *gravis corde* ut quid diligitis vanitatem, et quæritis mendacium?

Et scitote quoniam mirificavit Dominus sanctum suum : Dominus exaudiet me cum clamavero ad eum.

Irascimini, et nolite peccare : quæ *qui dicitis* dicitis in cordibus vestris, et in cubilibus vestris compungimini.

Sacrificate sacrificium justitiæ, et sperate in Domino : multi dicunt, Quis ostendit nobis bona ?

Signatum est super nos lumen vultus tui, Domine : dedisti lætitiã in corde meo.

A fructu frumenti, vini, et olei sui : *A tempore frum* multiplicati sunt.

In pace in idipsum : dormiam et *obdormiam* requiescam.

Quoniam tu, Domine, singulariter in spe : constituisti me.

PSALMUS V.

VERBA mea auribus percipe, Domine : intellige clamorem meum. Monday Lauds. Mattins of the departed.

Intende voci orationis meæ : Rex meus et Deus meus.

Quoniam ad te orabo, Domine : mane exaudies vocem meam.

Mane astabo tibi et videbo : quoniam non Deus volens iniquitatem tu es.

Neque habitabit juxta te malignus : neque permanebunt injusti ante oculos tuos.

mentation prayer, and applies to that moment when, while the world was still standing in awe at the supernatural darkness, He cried of "the Sacrifice of Righteousness," "It is finished." Doubtless a ray of Divine light comforted the broken heart of the dying Jesus as He commended His soul to His Father. He knew that the Lord had heard Him, and would glorify again the Name which He had already glorified. And so while the people said, "He saved others, Himself He cannot save," Jesus looked forth on the travail of His soul, and was satisfied. The Life-giving Corn and Wine had been perfected, the Uncion from the Holy One had been bought by the atoning blood, and now for ever was the Sufferer set at liberty, in peace to take His rest.

Even thus is the true peace and rest of the Church to be found in the Sacramental Life by which it is made the mystical Body of Christ ; and whether in life or in death the members of that

Body may dwell safely and in hope, through Him who is the Corn, the Wine, and the Oil of their souls.

It has been said of these four Psalms which open the Psalter that they contain an epitome of the Gospel. In the first we have the Life of Christ, in the second His Passion, in the fourth His Death and Burial, in the third His Resurrection.

PSALM V.

The third verse of this Psalm appears to indicate that it was composed for morning use ; and both in the Eastern and the Western systems it is thus appropriated to the second Morning Service, or Lauds, on Monday.

It is, throughout, the voice of the Church speaking to Christ. As in the dawn of its existence the Church prayed that the Lord would grant unto His servants that with all boldness they might speak His word, and that He would stretch forth His hand to

The I. Day.
Morning
Prayer.

6 Thou shalt destroy them that speak leasing : the Lord will abhor both the bloodthirsty and deceitful man.

7 But as for me, I will come into thine house, even upon the multitude of thy mercy : and in thy fear will I worship toward thy holy temple.

Acts iv. 29, 30.

8 Lead me, O Lord, in thy righteousness, because of mine enemies : make thy way plain before my face.

9 For there is no faithfulness in his mouth : their inward parts are very wickedness.

Rom. iii. 13.

10 Their throat is an open sepulchre : they flatter with their tongue.

11 Destroy thou them, O God, let them perish through their own imaginations : cast them out in the multitude of their ungodliness ; for they have rebelled against thee.

12 And let all them that put their trust in thee rejoice : they shall ever be giving of thanks, because thou defendest them ; they that love thy Name, shall be joyful in thee ;

Gen xv. 1.

13 For thou, Lord, wilt give thy blessing unto the righteous : and with thy favourable kindness wilt thou defend him as with a shield.

THE VI PSALM.

Domine, ne in furore.

Evening
Prayer.
Ash-Wed. Mat-
tins.
A penitential Ps.
Rev. iii. 19.

O LORD, rebuke me not in thine indignation : neither chasten me in thy displeasure.

2 Have mercy upon me, O Lord, for I am weak : O Lord, heal me, for my bones are vexed.

John xii. 27.
Lament. i. 12.

3 My soul also is sore troubled : but, Lord, how long wilt thou punish me ?

4 Turn thee, O Lord, and deliver my soul : O save me for thy mercy's sake.

Odisti omnes qui operantur iniquitatem : perdes omnes qui loquuntur mendacium. Od. Domine, omnes perdes eos qui

Virum sanguinum et dolosum abominabitur Dominus : ego autem in multitudine misericordiæ tuæ.

Introibo in domum tuam : adorabo Int. Domine, in ad templum sanctum tuum in timore tuo.

Domine, deduc me in justitia tua propter inimicos meos : dirige in conspectu tuo viam meam.

Quoniam non est in ore eorum veritas : cor eorum vanum est.

Sepulchrum patens est guttur eorum ; linguis suis dolose agebant : judica illos Deus.

Decidant a cogitationibus suis ; secundum multitudinem impietatum eorum expelle eos : quoniam irritaverunt te, Domine. quoniam exacer-
averunt te

Et lætentur omnes qui sperant in te : in æternum exsultabunt, et habitabis in eis.

Et gloriabuntur in te omnes qui diligunt nomen tuum : quoniam tu Domine, bene-
dices justum

Domine, ut scuto bonæ voluntatis tuæ : coronasti nos.

PSALMUS VI.

DOMINE, ne in furore tuo arguas me : neque in ira tua corripas me. Sunday Mattins.
1st Noct.
Matt. of the de-
parted.
ne in ira . . . neque
in furore

Miserere mei, Domine, quoniam infirmus sum : sana me Domine, quoniam conturbata sunt ossa mea. omnia ossa

Et anima mea turbata est valde : sed tu, Domine, usquequo ?

Convertere, Domine, et eripe animam meam : salvum me fac propter misericordiam tuam.

PSALM VI.

In this first of the seven penitential Psalms we begin to hear the voice of our Redeemer speaking as One upon whom the Lord hath laid the iniquity of us all, and whose visage was marred more than any man's in the awful hours of darkness which He suffered upon the cross. No one was ever so humbled by sin as the Son of God, who condescended to a shameful death for sinners : no one ever so felt the wrath of God poured out upon Him as He whose loving heart was broken by the rebuke of the Lord, so that He cried, "My God, My God, why hast Thou for-

work signs and wonders ; so now does she direct her constant prayer that His Presence may bless the opening day, and that He will direct her way.

It is well, in using this and other Psalms in which the destruction of enemies is spoken of, to remember that they are God's enemies, and the enemies of His Church and law, against whom the words are uttered ; and that the destruction of evil for the salvation of the repentant evil-doer is the highest exercise of Divine mercy. Nor must it be forgotten that as wickedness is essentially hateful to the All-Good, so there is a "wrath" even "of the Lamb" whose meekness and love are infinite.

The I. Day.
Evening
Prayer.

5 For in death no man remembereth thee : and who will give thee thanks in the pit ?

Jer. ix. 1.
Lament. viii. 49.
i. 16.

6 I am weary of my groaning, every night wash I my bed : and water my couch with my tears.

Isa. liii. 2.

7 My beauty is gone for very trouble : and worn away because of all mine enemies.

Matt. vii. 23.
Cf. LXX.

8 Away from me, all ye that work vanity : for the Lord hath heard the voice of my weeping.

9 The Lord hath heard my petition : the Lord will receive my prayer.

Luke x. 18.

10 All mine enemies shall be confounded, and sore vexed : they shall be turned back, and put to shame suddenly.

THE VII PSALM.

Domine, Deus meus.

Heb. ii. 13.

O LORD my God, in thee have I put my trust : save me from all them that persecute me, and deliver me ;

1 Pet. v. 8.

2 Lest he devour my soul like a lion, and tear it in pieces : while there is none to help.

1 Pet. ii. 22.

3 O Lord my God, if I have done any such thing : or if there be any wickedness in my hands ;

4 If I have rewarded evil unto him that dealt friendly with me : yea, I have delivered him that without any cause is mine enemy ;

5 Then let mine enemy persecute my soul, and take me : yea, let him tread my life down upon the earth, and lay mine honour in the dust.

6 Stand up, O Lord, in thy wrath, and lift up thyself, because of the indignation of mine enemies : arise up for me in the judgement that thou hast commanded.

Quoniam non est in morte qui memor sit tui : in inferno autem quis confitebitur tibi ?

Laboravi in gemitu meo, lavabo per singulas noctes lectum meum : lacrymis meis stratum meum rigabo.

Turbatus est a furore oculus meus : est præ ira oculus inveteravi inter omnes inimicos meos.

Discedite a me omnes qui operamini iniquitatem : quoniam exaudivit Dominus vocem fletus mei.

Exaudivit Dominus deprecationem meam : Dominus orationem meam sus- meam adsumpsit cepit.

Erubescant et conturbentur vehementer omnes inimici mei : convertantur et erubescant valde velociter. conturbentur omnes avertantur retrorsum

PSALMUS VII.

DOMINE, Deus meus, in te speravi : Sunday Mattins 1st Noct. Matt. of the departed. libera me ab omnibus . . . et eripe me salvum me fac ex omnibus persequentibus me, et libera me.

Nequando rapiat ut leo animam meam : dum non est qui redimat, neque qui salvum faciat.

Domine, Deus meus, si feci istud : si est iniquitas in manibus meis.

Si reddidi retribuentibus mihi mala : decidam merito ab inimicis meis inanis.

Persequatur inimicus animam meam et comprehendat, et conculcet in terra vitam meam : et gloriam meam in pulverem deducat.

Exsurge, Domine, in ira tua : et exaltare in finibus inimicorum meorum.

saken Me?" Yet, as God has said, "As many as I love I rebuke and chasten," so His love for sinners was shown in the chastisement which was laid upon the Redeemer of sinners, and in the rebuke which shed forth that Redeemer's Blood for their salvation.

Since our Lord and Saviour thus condescended to be so entirely one of ourselves that He was "made sin for us," and could utter the words of one bowed down by the burden, so has He thus set us an example of words wherein each sinner may turn to God with words of penitence in deprecation of His indignation and displeasure. And as the darkness passed away with the returning Light of the Father's Presence, so can all sinners hope

that a penitential confession of sin will end in words of joy through the application of the healing absolution, "Thy sins are forgiven thee."

PSALM VII.

The second verse of this Psalm points out the adversary spoken of as that one of whom St. Peter speaks as a roaring lion walking about seeking whom he may devour ; and of whom David had already found an evil type when he was guarding the flock entrusted to him by his father. [1 Sam. xvii. 34.] And since the adversary is Satan, so the Person speaking must be Christ, the seed of the woman persecuted by the Evil One, the seed of the

The I. Day.
Evening
Prayer.
John xii. 32.

7 And so shall the congregation of the people come about thee : for their sakes therefore lift up thyself again.

8 The Lord shall judge the people ; give sentence with me, O Lord : according to my righteousness, and according to the innocency that is in me.

John xii: 31.
Rev. xx. 10.

9 O let the wickedness of the ungodly come to an end : but guide thou the just.

Rev. ii. 23.

10 For the righteous God : trieth the very hearts and reins.

11 My help cometh of God : who preserveth them that are true of heart.

12 God is a righteous judge, strong, and patient : and God is provoked every day.

13 If a man will not turn, he will whet his sword : he hath bent his bow, and made it ready.

14 He hath prepared for him the instruments of death : he ordaineth his arrows against the persecutors.

15 Behold, he travaileth with mischief : he hath conceived sorrow, and brought forth ungodliness.

Rev. ix. 11.
xx. 3. 14.

16 He hath graven and digged up a pit : and is fallen himself into the destruction that he made for other.

Matt. xxvii. 5.

17 For his travail shall come upon his own head : and his wickedness shall fall on his own pate.

John xi. 41.
Rev. xi. 17, 18.

18 I will give thanks unto the Lord, according to his righteousness : and I will praise the Name of the Lord most High.

Et exsurge, Domine, Deus meus, in præcepto quod mandasti : et synagoga populorum circumdabit te.

Et propter hanc in altum regredere : Dominus judicat populos.

Domine, judica

Judica me, Domine, secundum justitiam meam : et secundum innocentiam meam super me.

innoc. manuum mearum

Consumetur nequitia peccatorum, et diriges justum : scrutans corda et renes Deus.

dirige

Justum adjutorium meum a Domino : qui salvos facit rectos corde.

Deus judex justus, fortis, et patiens : numquid irascitur per singulos dies ?

fortis et longanimis

Nisi conversi fueritis, gladium suum vibravit : arcum suum tetendit, et paravit illum.

convertamini

Et in eo paravit vasa mortis : sagittas suas ardentibus effecit.

in ipso

Ecce parturit injustitiam : concepit dolorem : et peperit iniquitatem.

Lacum aperuit, et effodit eum : et incidit in foveam quam fecit.

Convertetur dolor ejus in caput ejus : et in verticem ipsius iniquitas ejus descendet.

in capite

in vertice ejus

Confitebor Domino secundum justitiam ejus : et psallam Nomini Domini Altissimi.

serpent whose head He was to bruise. Many a lamb had the lion seized out of the flock, and at last he strove to tear in pieces the Lamb of God Himself. All through the Psalm it is this personal Adversary who is spoken of ; and even when the enemies of Christ are represented as many, the one power and influence by which they are moved is recalled to our minds by the interchange of the plural and the singular number.

The plea of innocence which is made in the third, fourth, and fifth verses, is mingled with a prophetic foreshadowing of that which is now history, that "He who did no sin, neither was guile found in His mouth," was yet "made sin" for us, had His holy body torn in pieces, His soul persecuted, His life trodden down upon the earth, and His honour laid in the dust. Thus David in his affliction prophetically personified Him whose bitter Passion wrought out the Atonement, and who, "while we were enemies, yet died for us."

Then, as in previous Psalms, a sudden transition takes place from the "dust" of death to the "lifting up" of the Resurrection. In one sense it is the voice of Christ calling upon His

Father to glorify His Name now that the purpose of His humiliation and suffering is accomplished : in another it is the voice of the Church calling upon Christ to lift up Himself again in the Resurrection for the sake of those whom He has redeemed, that they who are partakers of His death may also be partakers of His Life and His Glory. Then, although all forsook Him and fled, and none were left around Him but a congregation of wicked doers and cruel men, when He had ascended up on high, to take up His Divine Glory again, He should gather about Him in the Kingdom of the Resurrection a congregation of the people, whose multitude no man can number, out of all nations, and peoples, and tongues. "I, if I be lifted up, will draw all men unto Me."

In the latter verses, the final subjugation of the Evil One is predicted, the second death of the lake of fire, and the bottomless pit into which the great enemy himself shall be cast. [Rev. xx. 10. 14.] Thus also the ninth verse is another form of the prayer, "Thy kingdom come . . . deliver us from evil : " a prayer that God may be all and in all.

THE VIII PSALM.

Domine, Dominus noster:

The I. Day.
Evening
Prayer.
Ascension Day
Mattins.

O LORD our Governour, how excellent is thy Name in all the world : thou that hast set thy glory above the heavens.

Math. xxi. 16.
Isa. ix. 6.

2 Out of the mouth of very babes and sucklings hast thou ordained strength, because of thine enemies : that thou mightest still the enemy and the avenger.

3 For I will consider thy heavens, even the works of thy fingers : the moon and the stars which thou hast ordained.

Heb. ii. 6--8.

4 What is man, that thou art mindful of him : and the son of man, that thou visitest him ?

1 Pet. iii. 22.

5 Thou madest him lower than the angels : to crown him with glory and worship.

1 Cor. xv. 27.

6 Thou makest him to have dominion of the works of thy hands : and thou hast put all things in subjection under his feet ;

John x. 27.
1 Cor. ix. 9.

7 All sheep and oxen : yea, and the beasts of the field ;

Phil. ii. 9, 10.

8 The fowls of the air, and the fishes of the sea : and whatsoever walketh through the paths of the seas.

9 O Lord our Governour : how excellent is thy Name in all the world.

THE IX PSALM.

Confitebor tibi.

The II. Day.
Morning
Prayer.

I WILL give thanks unto thee, O Lord; with my whole heart : I will speak of all thy marvellous works.

PSALMUS VIII.

DOMINE Dominus noster : quam admirabile est Nomen tuum in universa terra. Sunday Mattins.
1st Noct.

Quoniam elevata est magnificentia tua : super cœlos.

Ex ore infantium et lactentium perfecisti laudem propter inimicos tuos : *et defensorem* ut destruas inimicum et ultorem.

Quoniam videbo cœlos tuos, opera digitorum tuorum : lunam et stellas quæ tu fundasti.

Quid est homo, quod memor es ejus? aut filius hominis quoniam visitas eum?

Minuisti eum paulominus ab angelis, gloria et honore coronasti eum : et constituisti eum super opera manuum tuarum.

Omnia subjecisti sub pedibus ejus ; oves et boves universas : insuper et pecora campi.

Volucres cœli, et pisces maris : qui perambulant semitas maris.

Domine Dominus noster : quam admirabile est Nomen tuum in universa terra.

PSALMUS IX.

CONFITEBOR tibi, Domine, in toto corde meo : narrabo omnia mirabilia tua. Sunday Mattins.
1st Noct.

PSALM VIII.

The Church sings this Psalm to the glory of the Son of Man, our Lord as Creator, and our Lord as Redeemer, who has been crowned with the glory of an everlasting kingdom, and a never-ending Divine Worship in heaven and earth.

The prophecy of the second verse is declared by Christ Himself to have been fulfilled by the children crying "Hosanna to the Son of David" as He rode into Jerusalem on Palm Sunday. We need not, however, suppose this to be its only fulfilment, for the Holy Innocents glorified the Holy Babe by their deaths, and an army of Holy Innocents "follow the Lamb whithersoever He goeth" in His glorified Kingdom. Above all other babes out of whose mouth strength has been ordained is He of Whom it is written, "Unto us a Child is born, unto us a Son is given, and His Name shall be called Wonderful, the Mighty God."

Hence St. Paul guides us to that use of this Psalm which is specially marked out by its selection for Ascension Day : and

"we see Jesus" in Him "Who was made a little lower than the angels for the suffering of death, crowned with glory and honour." But when we thus sing the glory of Him Who is the Alpha and Omega,—the Lord our Lord in the beginning, and the Lord our Lord in the end,—we may also remember that "both He that sanctifieth and they who are sanctified are all of one," and that we sing also of the exaltation of human nature by its union with Him through His Incarnation and Ascension.

PSALM IX.

A song of Christ and of His Church, setting forth the triumph of His Person and His work, and giving thanks because He Who became poor for our sakes hath made many rich to the glory of God.

The marvellous works of God in the miracles of grace are even more worthy to be sung than those which surround us in the miracles of Creation and Providence. Especially in that miracle of grace from which all others spring, that of our Lord's Incarna-

The II. Day.
Morning
Prayer.

John xviii. 6.
Matt. xxviii. 4.

2 I will be glad and rejoice in thee : yea, my songs will I make of thy Name, O thou most Highest.

3 While mine enemies are driven back : they shall fall and perish at thy presence.

4 For thou hast maintained my right and my cause : thou art set in the throne that judgest right.

5 Thou hast rebuked the heathen, and destroyed the ungodly : thou hast put out their name for ever and ever.

6 O thou enemy, destructions are come to a perpetual end : even as the cities which thou hast destroyed ; their memorial is perished with them.

Rev. xx. 11.

7 But the Lord shall endure for ever : he hath also prepared his seat for judgement.

Rev. xx. 12.

8 For he shall judge the world in righteousness : and minister true judgement unto the people.

9 The Lord also will be a defence for the oppressed : even a refuge in due time of trouble.

Phil. ii. 9.

10 And they that know thy Name, will put their trust in thee : for thou, Lord, hast never failed them that seek thee.

11 O praise the Lord which dwelleth in Sion : shew the people of his doings.

Gen. iv. 9.
Heb. xii. 24.
Matt. xxvii. 25.
Luke xxiii. 34.

12 For, when he maketh inquisition for blood, he remembereth them : and forgetteth not the complaint of the poor.

13 Have mercy upon me, O Lord, consider the trouble which I suffer of them that hate me : thou that liftest me up from the gates of death.

14 That I may shew all thy praises within the ports of the daughter of Sion : I will rejoice in thy salvation.

Lætabor et exultabo in te : psallam
Nomini tuo, Altissime.

In convertendo inimicum meum retrorsum : infirmabuntur, et peribunt a facie tua.

Quoniam fecisti judicium meum et causam meam : sedes super thronum qui judicas justitiam.

Incepisti gentes, et perit impius : nomen eorum delēsti in æternum et in sæculum sæculi.

Inimici defecerunt framæ in finem : et civitates eorum destruxisti.

Perit memoria eorum cum sonitu : et Dominus in æternum permanet.

Paravit in judicio thronum suum : sedem suam et ipse judicabit orbem terræ in æquitate ; judicabit populos in justitia.

Et factus est Dominus refugium pauperi : adjutor in opportunitatibus, in tribulatione.

Et sperent in te qui noverunt Nomen in te omnes qui tuum : quoniam non dereliquisti querentes te, Domine.

Psallite Domino, qui habitat in Sion : annuntiate inter gentes studia mirabilia ejus.

Quoniam requirens sanguinem, eorum recordatus est : non est oblitus clamorem pauperum. memoratus est orationem paup.

Miserere mei, Domine : vide humilitatem meam de inimicis meis.

Qui exaltas me de portis mortis : ut annuntiem omnes laudationes tuas in omnes laudes portis filiæ Sion.

tion: "Great is the mystery of godliness; God was manifest in the flesh," the angels and those who recognized their Saviour rejoiced, while the enemy was confounded and death vanished in presence of Him Who is the Life. As the multitude with swords and staves who came to take Jesus went backward and fell to the ground at the proclamation of the Incommunicable Name, and as the keepers became as dead men in sight of the Resurrection glory, so the darkness of heathenism fled before the Light of the world, the universally destructive empire of the Enemy of God and man was broken up, and the Throne of the Cross was established for ever.

The "inquisition for blood" speaks of that blood of which the Jews said, "Let it be on us and on our children," and which speaketh

better things than that of Abel; the complaint of the Poor, crying up to God "Father, forgive them, for they know not what they do." It speaks also of the blood of the martyrs, Stephen praying, "Lord, lay not this sin to their charge," and the souls under the altar crying, "Lord, how long, O Lord, holy and true, dost Thou not judge and avenge our blood on them that dwell on the earth?"

In the continued prayer for mercy and deliverance, an illustration is given of the oneness which Christ establishes between Himself and the Church. When Saul hunted down the members of Christ to slaughter, the Lord met him and said, "Saul, Saul, why persecutest thou ME?" In the same manner the Voice of the Head is heard speaking of the "trouble" which He suffers

The II. Day.
Morning
Prayer.

15 The heathen are sunk down in the pit that they made : in the same net which they hid privily, is their foot taken.

16 The Lord is known to execute judgement : the ungodly is trapped in the work of his own hands.

17 The wicked shall be turned into hell : and all the people that forget God.

18 For the poor shall not alway be forgotten : the patient abiding of the meek shall not perish for ever.

19 Up Lord, and let not man have the upper hand : let the heathen be judged in thy sight.

20 Put them in fear, O Lord : that the heathen may know themselves to be but men.

THE X PSALM.

Ut quid, Domine?

Matt. xxvii. 46.

WHY standest thou so far off, O Lord : and hidest thy face in the needful time of trouble?

2 The ungodly for his own lust doth persecute the poor : let them be taken in the crafty wiliness that they have imagined.

3 For the ungodly hath made boast of his own heart's desire : and speaketh good of the covetous whom God abhorreth.

4 The ungodly is so proud, that he careth not for God : neither is God in all his thoughts.

5 His ways are alway grievous : thy judgements are far above out of his sight, and therefore defieth he all his enemies.

2 Thess. ii. 4.
Dan. xi. 37.

6 For he hath said in his heart, Tush, I shall never be cast down : there shall no harm happen unto me.

Exultabo in salutari tuo: infixæ sunt gentes in interitu quem fecerunt.

In laqueo isto quem absconderunt: *occulaverunt* comprehensus est pes eorum.

Cognoscetur Dominus iudicia faciens: in operibus manuum suarum *Cognoscitur* comprehensus est peccator.

Convertantur peccatores in infernum: omnes gentes quæ obliviscuntur Deum.

Quoniam non in finem oblivio erit pauperis: patientia pauperum non peribit in finem.

Exurge, Domine; non confortetur *non praveat* homo; judicentur gentes in conspectu tuo.

Constituæ, Domine, legislatorem super eos: ut sciant gentes quoniam homines sunt.

[PSALMUS IX., v. 22.]

UT quid, Domine, recessisti longè: despicias in opportunitatibus, in tribulatione?

Dum superbit impius, incenditur pauper: comprehenduntur in consiliis *in cogitationibus suis quas* quibus cogitant.

Quoniam laudatur peccator in desideris animæ suæ: et iniquus bene- *qui iniqua gerit* dicitur.

Exacerbavit Dominum peccator: *Irritavit* secundum multitudinem iræ suæ non quæret.

Non est Deus in conspectu ejus: inquinatæ sunt viæ illius in omni *polluuntur viæ ejus* tempore.

Auferuntur iudicia tua a facie ejus: omnium inimicorum suorum dominabitur.

in His members from them that hate Him; and with His mystical body He prays to the Divine Nature, Arise, O Lord, in the power of the Resurrection, and establish THE POOR in His kingdom as a Lawgiver and a Saviour.

PSALM X.

"Man's necessity is God's opportunity," yet the cry with which this Psalm opens expresses literally the utter forsakenness of Christ even "in opportunitatibus, in tribulatione," when the Lord is to all others a defence and a refuge: to such an utter depth of persecution and suffering did "the Poor" descend for the sake of those He came to save.

This Psalm is in reality a continuation of the ninth, as it is

written in the LXX and the Vulgate, and as is shown by the initial letters of the verses, which in the Hebrew form the Alphabet, beginning with the first verses of the ninth and ending with the last verses of the tenth.

But as the enemies of the Poor in the former Psalm are the heathen, persecuting Christ and His Church from without, so in this they are from within, those of His own household. Consequently this latter Psalm has ever been interpreted of the troubles which the Church will have to undergo in the days of Antichrist, when the greatest enemy that has ever persecuted the mystical Body of Christ, will arise from among its members.

Antichristian pride is here predicted as if it would be a revivification in practical life of the first temptation that men "should

The II. Day.
Morning
Prayer.
Rom. iii. 14.

7 His mouth is full of cursing, deceit, and fraud : under his tongue is ungodliness and vanity.

8. He sitteth lurking in the thievish corners of the streets : and privily in his lurking dens doth he murder the innocent ; his eyes are set against the poor.

9 For he lieth waiting secretly, even as a lion lurketh he in his den : that he may ravish the poor.

10 He doth ravish the poor : when he getteth him into his net.

11 He falleth down, and humbleth himself : that the congregation of the poor may fall into the hands of his captains.

12 He hath said in his heart, Tush, God hath forgotten : he hideth away his face, and he will never see it.

13 Arise, O Lord God, and lift up thine hand : forget not the poor.

14 Wherefore should the wicked blaspheme God : while he doth say in his heart, Tush, thou God carest not for it.

15 Surely thou hast seen it : for thou beholdest ungodliness and wrong.

16 That thou mayest take the matter into thine hand : the poor committeth himself unto thee ; for thou art the helper of the friendless.

17 Break thou the power of the ungodly and malicious : take away his ungodliness, and thou shalt find none.

Rev. xi. 15.

18 The Lord is King for ever and ever : and the heathen are perished out of the land.

19 Lord, thou hast heard the desire of the poor : thou preparest their heart, and thine ear hearkeneth thereto ;

20 To help the fatherless and poor unto their right : that the man of the earth be no more exalted against them.

Dixit enim in corde suo : Non movebor a generatione in generationem sine malo.

Cujus maledictione os plenum est, et amaritudine, et dolo : sub lingua ejus labor et dolor.

Sedet in insidiis cum divitibus in occultis : ut interficiat innocentem.

Oculi ejus in pauperem respiciunt : insidiatur in abscondito, quasi leo in spelunca sua. oculto sicut leo in cubili suo

Insidiatur ut rapiat pauperem : rapere pauperem dum attrahit eum. abstrahet

In laqueo suo humiliabit eum : inclinabit se, et cadet cum dominatus fuerit pauperum. dominabitur pauperi

Dixit enim in corde suo ; Oblitus est Deus : avertit faciem suam ne videat in finem. usque in fin.

Exurge, Domine Deus, et exaltetur manus tua : ne obliviscaris pauperem. paup. in finem

Propter quid irritavit impius Deum ? dixit enim in corde suo, non requiret. req. Deus

Vides ; quoniam tu laborem et dolorem consideras : ut tradas eos in manus tuas.

Tibi derelictus est pauper : orphano tu eris adjutor. pupillo

Contere brachium peccatoris et maligni : quaeretur peccatum illius, et non invenietur. requiretur delictum ejus nec

Dominus regnabit in aeternum et in saeculum saeculi : peribitis gentes de terra illius.

Desiderium pauperum exaudivit Dominus : preparationem cordis eorum audivit auri tua. desiderium . . . exaudivit

Judicare pupillo et humili : ut non apponat ultra magnificare se homo super terram.

be as Gods." And, as the enemies of Christ allied themselves with the covetous traitor, so it is a characteristic of the spirit of Antichrist that covetousness, which God declares to be the root of all evil, is by him spoken good of, and reckoned as a virtue. The unjust steward is commended, in such a spirit, because he was wise in his generation, that generation being narrowed within the bounds of this present life.

It is, perhaps, more of this future conflict between the kingdom of the Poor and the kingdom of Antichrist, than of the personal sufferings of Christ in His Passion that this Psalm speaks. And the conclusion is a prophecy that although the eyes of those who

follow the enemy of Christ may be so wilfully blinded that they can see no God, no Christ, no world to come, yet God will hear the prayer of His Church, "Thy kingdom come," "the kingdoms of this world shall become the kingdoms of our Lord, and of His Christ, and He shall reign for ever and ever." As Christ said, "I will not leave you orphans," so His promise will be fulfilled : the Poor shall enter on His reign of glory, the fatherless shall sit down with Him in the kingdom of His Father and theirs, and the power of Antichrist will be cast down, broken, and destroyed.

THE XI PSALM.

In Domino confido.

The II. Day.
Morning
Prayer.

IN the Lord put I my trust : how say ye then to my soul, that she should flee as a bird unto the hill ?

2 For lo, the ungodly bend their bow, and make ready their arrows within the quiver : that they may privily shoot at them which are true of heart.

Acts iii. 14.
vii. 52.
Luke xxiii. 41.

3 For the foundations will be cast down : and what hath the righteous done ?

4 The Lord is in his holy temple : the Lord's seat is in heaven.

5 His eyes consider the poor : and his eye-lids try the children of men.

" trieth " B. V.

6 The Lord alloweth the righteous : but the ungodly, and him that delighteth in wickedness doth his soul abhor.

7 Upon the ungodly he shall rain snares, fire and brimstone, storm, and tempest : this shall be their portion to drink.

1 John ii. 29.
iii. 7.

8 For the righteous Lord loveth righteousness : his countenance will behold the thing that is just.

THE XII PSALM.

Salvum me fac.

Evening
Prayer.

HELP me, Lord, for there is not one godly man left : for the faithful are minished from among the children of men.

Luke xx. 19—26.

2 They talk of vanity every one with his neighbour : they do but flatter with their lips, and dissemble in their double heart.

Matt. xv. 13.

3 The Lord shall root out all deceitful lips : and the tongue that speaketh proud things.

PSALMUS X.

IN Domino confido : quomodo dicitis animæ meæ, Transmigra in montem sicut passer ? Sunday Mattins.
1st Noct.

Quoniam ecce peccatores intendebunt arcum ; paraverunt sagittas suas in pharetra : ut sagittent in obscuro rectos corde.

Quoniam quæ perfecisti destruxerunt : justus autem quid fecit ?

Dominus in templo sancto suo : Dominus in cœlo sedes ejus.

Oculi ejus in pauperem respiciunt : palpebræ ejus interrogant filios hominum.

Dominus interrogat justum et impium : qui autem diligit iniquitatem, odit animam suam.

Pluet super peccatores laqueos : ignis, et sulphur, et spiritus procellarum, pars calicis eorum.

Quoniam justus Dominus, et justitias dilexit : æquitatem vidit vultus ejus.

PSALMUS XI.

SALVUM me fac, Domine, quoniam defecit sanctus : quoniam diminutæ sunt veritates a filiis hominum. Sunday Mattins.
1st Noct.

Vana locuti sunt unusquisque ad proximum suum : labia dolosa, in corde et corde locuti sunt. locutus est unusq.
loc. sunt mala

Disperdat Dominus universa labia dolosa : et linguam magniloquam. maliloquam

PSALM XI.

This is, doubtless, spoken primarily of "Jesus Christ the Righteous," "the Holy One and the Just," "that Just One," against Whom the ungodly Jews bent their bows of hatred, and made ready their arrows of slander and false witness. For a short time He went away from them "unto a country near to the wilderness into a city called Ephraim," probably between Jerusalem and Jericho, but when His time was approaching, six days before the Passover, He returned to Jerusalem, going willingly to His sufferings. It may be that there was some advice given to Him identical with that implied in the opening verse of this Psalm, such as the words of St. Peter, "That be far from Thee, Lord ;" or of the other disciples, "The Jews of late sought

to stone Thee, and goest Thou thither again?" In the same manner the Church has at times retired from the fierceness of persecution into the deserts of Egypt and Palestine, or the Catacombs of Rome ; but, with her Head, ever looking upward faithfully and beholding the Throne of the righteous Judge in Heaven. For a time He tries the Church as He tried the Righteous and the Poor Himself, but chastening as a Father : and the light of His countenance shining above all trial gives sure confidence that the just cause, the cause which is His own, will in the end most surely prevail.

PSALM XII.

This Psalm represents the mournful spirit in which Christ looked upon the unbelieving heart of the generation that beheld

The II. Day.
Evening
Prayer.
Matt. xvi. 1.
xxvii. 63.
John xix. 20.

4 Which have said, With our tongue will we prevail : we are they that ought to speak, who is Lord over us ?

Lament. i. 21, 22.
Mark vii. 34.
viii. 12.

5 Now for the comfortless troubles' sake of the needy : and because of the deep sighing of the poor ;

Isa. liii. 9, 12.

6 I will up, saith the Lord : and will help every one from him that swelleth against him, and will set him at rest.

7 The words of the Lord are pure words : even as the silver, which from the earth is tried, and purified seven times in the fire.

8 Thou shalt keep them, O Lord : thou shalt preserve him from this generation for ever.

1 Pet. v. 8.

9 The ungodly walk on every side : when they are exalted, the children of men are put to rebuke.

THE XIII PSALM.

Usque quo, Domine ?

Rev. vi. 9.

HOW long wilt thou forget me, O Lord, for ever : how long wilt thou hide thy face from me ?

2 How long shall I seek counsel in my soul, and be so vexed in my heart : how long shall mine enemies triumph over me ?

Isa. lx. 1.
Luke ii. 32.

3 Consider and hear me, O Lord my God : lighten mine eyes, that I sleep not in death.

John xvi. 21.

4 Lest mine enemy say, I have prevailed against him : for if I be cast down, they that trouble me will rejoice at it.

Qui dixerunt, Linguam nostram magnificabimus : labia nostra a nobis sunt ; quis noster Dominus est ?

Propter miseriam inopum, et gemitum pauperum : nunc exurgam, dicit Dominus.

Ponam in salutari : fiducialiter agam Ponam super salutare meum in eo.

Eloquia Domini, eloquia casta ; argentum igne examinatum : probatum terræ, purgatum septuplum.

Tu, Domine, servabis nos, et custodies nos : a generatione hac in æternum.

In circuitu impii ambulant : secundum altitudinem tuam multiplicasti filios hominum.

PSALMUS XII.

USQUEQUO, Domine, oblivisceris me in finem ? usquequo avertis faciem tuam a me ? Sunday Mattins. 1st Noct.

Quamdiu ponam consilia in anima mea ? dolorem in corde meo per diem ? consilium in animam meam

Usquequo exaltabitur inimicus meus super me ? respice, et exaudi me, Domine Deus meus.

Illumina oculos meos ne unquam obdormiam in morte : nequando dicat inimicus meus, Prævalui adversus eum.

Him, and at the contradiction of sinners against Himself. It is also the voice of His mystical Body, crying, "Lord, how long," and praying for the Second Advent and perfect Dominion of the Son of Man.

There were times in the life of our Lord when not even "His brethren" believed in Him, and when all forsook Him and fled. With rare exceptions, those who accepted Him and His mission were but a "little flock," and while the whole nation of the Jews desired a temporal Sovereign who should re-establish their national independence, there were but few who faithfully "waited for the Redemption of Israel" by a spiritual Saviour.

The details of the Psalm have a special application to the life of the Son of David. The three principal sects of the Jews, the Pharisees, Sadducees, and Herodians, tempted Him with flattering words, and endeavoured by dissembling to entice Him into some declaration which they could use against Him in their courts of law. But the words of the Lord were ever pure words ; the very officer sent to take Him said, "Never man spake like this man ;" and so completely did He convict the tempters out of their own mouth, that at last "no man durst ask Him any more

questions." They endeavoured to prevail with their tongue, but the Lord rooted out all deceitful lips by the Omniscient searching of that Word which is as a two-edged sword.

It may be observed that the "deep sighing of the Poor" is here brought into close association with the evil use of the tongue ; while in the Gospel it is recorded of our Lord that He looked up to heaven, and sighed when He was about to give the faculty of speech to one who had been always deaf and dumb. Doubtless He sighed, knowing that He gave that faculty subject to the man's free will, and therefore subject to its use for evil as well as good.

PSALM XIII.

The voice of the mystical Body of Christ is here heard, with greater distinctness than in the preceding Psalm, expressing the longing of the Bride for the return of the Bridegroom. "The Spirit and the Bride say, Come." In the first two verses the cry of "the souls under the altar" is four times repeated ; but in such a manner as to remind the individual Christian that it is sin which causes the hiding of God's face from His children ; and

The II. Day.
Evening
Prayer.
Isa. xxv. 9.

5 But my trust is in thy mercy :
and my heart is joyful in thy salva-
tion.

6 I will sing of the Lord, because
he hath dealt so lovingly with me :
yea, I will praise the Name of the
Lord most Highest.

THE XIV PSALM.

Dixit insipiens.

THE fool hath said in his heart :
There is no God.

Rom. iii. 10. 2 They are corrupt, and become
abominable in their doing : there is
none that doeth good, no, not one.

Rom. iii. 11. 3 The Lord looked down from
heaven upon the children of men : to
see if there were any that would un-
derstand, and seek after God.

Rom. iii. 12. 4 But they are all gone out of the
way, they are altogether become
abominable : there is none that doeth
good, no, not one.

Rom. iii. 13. 5 Their throat is an open sepulchre,
with their tongues have they deceived :
the poison of asps is under their lips.

Rom. iii. 14, 15. 6 Their mouth is full of cursing,
and bitterness : their feet are swift to
shed blood.

Rom. iii. 16, 17,
18. 7 Destruction and unhappiness is in
their ways, and the way of peace have
they not known : there is no fear of
God before their eyes.

Iga. v. 13. 8 Have they no knowledge, that
they are all such workers of mischief :
Gal. v. 15. eating up my people as it were bread,
and call not upon the Lord ?

Qui tribulant me exsultabunt si mo-
tus fuero : ego autem in misericordia
tua speravi.

Exsultabit cor meum in salutari
tuo ; cantabo Domino qui bona tribuit
mihi : et psallam Nomini Domini
Altissimi.

*sperabo**two Alt.*

PSALMUS XIII.

DIXIT insipiens in corde suo : Sunday Mattins.
Non est Deus. 1st Noct.

Corrupti sunt, et abominabiles facti
sunt in studiis suis : non est qui faciat
bonum, non est usque ad unum. *in voluntatibus suis*

Dominus de cœlo prospexit super
filios hominum : ut videat si est intelli-
gens, aut requirens Deum.

Omnes declinaverunt ; simul inutiles
facti sunt : non est qui faciat bonum,
non est usque ad unum.

Sepulchrum patens est guttur eorum ;
linguis suis dolose agebant : venenum
aspidium sub labiis eorum.

Quorum os maledictione et amari-
tudine plenum est : veloces pedes
eorum ad effundendum sanguinem.

Contritio et infelicitas in viis eorum,
et viam pacis non cognoverunt : non
est timor Dei ante oculos eorum.

Nonne cognoscent omnes qui ope-
rantur iniquitatem : qui devorant ple-
bem meam sicut escam panis ?

that even when the Holy One Himself took such words as these upon His lips, it was because He was made sin for us, and in His own smitten and afflicted person represented a whole world of sinners.

Like most Psalms of this mournful character, the thirteenth divides into three portions which illustrate the transition of our Lord from a state of suffering and persecution, through the humiliation of death, to the triumph of resurrection. The experience of the Lord in the flesh was the experience of His mystical Body, and is also the experience of each of His members : the Lord and His Church in their contest with the world, the particular Christian in his conflict with sin. It seems frequently as if the enemy were about to be able to say, "I have prevailed ;" as if He that should have redeemed Israel had proved unable to do so, as if the Church could never overcome and counteract the work of Satan, as if the Christian soul was ever being cast down by the force of temptation. But as the darkness passed away from the Cross at the ninth hour, and the Father's countenance was again unveiled to the eyes of the Crucified, as the age of persecution and depression passed away from the Church, so Christ turns and looks upon the sinner whose trust is in His mercy, and

the daily prayer, "Lighten our darkness," is a continual memorial before God of the need, and before man of the power, of the Divine Presence.

PSALM XIV.

There is little absolute Atheism in the world, God having so fully revealed Himself that the inner light of conscience and the outer light of nature's evidences bear universal and overpowering testimony to His existence [Rom. i. 20]. But there is much of the more subtle Atheism of which the Jews were guilty, that denial of the Godhead of our Lord Jesus which underlies every system of religion that diverges from that of the Catholic Church.

This Psalm is a prophecy of that awful time when this denial of Christ will have become all but universal, through the acceptance by the world of the kingdom of Antichrist. Such denial may not be entirely open and avowed, for the Psalm says the fool hath "said in his heart," not with his lips, there is no God. As the system of Mahomet gives a subordinate position of honour to Christ, not denying Him altogether, so that of the final Antichrist will probably profess some specious respect for Him, ac-

The II. Day.
Evening
Prayer.

9 There were they brought in great fear, even where no fear was : for God is in the generation of the righteous.

Mark xv. 32.

10 As for you, ye have made a mock at the counsel of the poor : because he putteth his trust in the Lord.

11 Who shall give salvation unto Israel out of Sion? When the Lord turneth the captivity of his people : then shall Jacob rejoice, and Israel shall be glad.

THE XV PSALM.

Domine, quis habitabit?

The III. Day.
Morning
Prayer.

Ascension-day
Mattins.
Heb. ix. 11.
Luke ix. 33.
1 Pet. ii. 5.
Rev. xxi. 3.

LORD, who shall dwell in thy tabernacle : or who shall rest upon thy holy hill?

2 Even he, that leadeth an uncorrupt life : and doeth the thing which is right, and speaketh the truth from his heart.

1 Pet. ii. 22.
Isa. liiii. 9.
Cf. Rev. xii. 10.

3 He that hath used no deceit in his tongue, nor done evil to his neighbour : and hath not slandered his neighbour.

Phil. ii. 7.

4 He that setteth not by himself, but is lowly in his own eyes : and maketh much of them that fear the Lord.

5 He that sweareth unto his neighbour, and disappointeth him not : though it were to his own hindrance.

Rev. xxi. 6.
xxii. 17.
Matt. x. 8.
Cf. Matt. xxvii. 4.

6 He that hath not given his money upon usury : nor taken reward against the innocent.

7 Whoso doeth these things : shall never fall.

Deum non invocaverunt : illic trepidaverunt timore, ubi non erat timor.

Quoniam Dominus in generatione justa est : consilium inopis confudistis, *confudisti* quoniam Dominus spes ejus est.

Quis dabit ex Sion salutare Israël? cum averterit Dominus captivitatem *avertit*

plebis suæ, exultabit Jacob, et lætabitur Israël. *lætatur Jacob et exultat Israel*

PSALMUS XIV.

DOMINE, quis habitabit in tabernaculo tuo? aut quis requiescet in monte sancto tuo? *Sunday, Easter Eve. St. Michael, Matins. 1st Noct. Many Martyrs, 2nd Noct.*

Qui ingreditur sine macula : et operatur justitiam.

Qui loquitur veritatem in corde suo : qui non egit dolum in lingua sua.

Nec fecit proximo suo malum : et opprobrium non accepit adversus proximos suos. *proximum suum*

Ad nihilum deductus est in conspectu ejus malignus : timentes autem Dominum glorificat : *magnificat*

Qui jurat proximo suo, et non decipit : qui pecuniam suam non dedit ad usuram, et munera super innocentem non accepit.

Qui facit hæc : non movebitur in æternum. *commovebitur*

knowledging Him as worthy of great reverence while utterly refusing to acknowledge Him as worthy of the worship due to the Supreme; saying with Pilate, Ecce Homo, but not with the prophet, Behold your God.

The terrible words of this Psalm open out to us God's view of such Antichristianism, "The Lord looked down from Heaven." They show us that no compromise of moral goodness and unbelief is known to Him, but that he who says in his heart there is no God,—none in Heaven, none in Christ,—is to the eye of the All-Righteous and Omniscient "corrupt and abominable." All gradations of Atheism are thus associated with more or less of immorality.

PSALM XV.

In this, as in the first, Psalm there is an obvious application to Christ as the perfect ideal of the human nature personified: and this application is certified to us by the Church in the selection of it for an Ascension-day Psalm. The sense of it is fixed by the third verse, which is all but verbally identical with the two

passages marked against it in the margin, the one a directly prophetic, the other a directly historical, reference to the Messiah. Of Him alone, dwelling among men for a generation in the tabernacle of the flesh [*ἐσκήνωσεν ἐν ἡμῖν*, John i. 14], can it be said without any reservation that This was one who led an uncorrupt life; of Him alone that no "guile was found in His mouth;" of Him alone that He was wholly "meek and lowly of heart." In the fifth verse there is also a prophecy of the fulfilment by the Son of God of His purpose and promise to redeem mankind, even though that fulfilment entailed the taking upon Him the form of a servant, and suffering death upon the cross. He was the good Samaritan taking care of His neighbour, and bestowing on him the sacraments of life, to be bought without money and without price.

But the "tabernacle" of Christ's human Body calls also to mind the temple of His mystical Body, and hence the plain moral application of the Psalm becomes intensified into a rule of life for Christians as members of Him "Who did no sin." [Cf. Ascension-day Collect.]

THE XVI PSALM.

Conserva me, Domine.

The III. Day.
Morning
Prayer.

PRESERVE me, O God : for in thee have I put my trust.

2 O my soul, thou hast said unto the Lord : Thou art my God, my goods are nothing unto thee.

3 All my delight is upon the saints that are in the earth : and upon such as excel in virtue.

4 But they that run after another god : shall have great trouble.

John xvii. 9.

5 Their drink-offerings of blood will I not offer : neither make mention of their names within my lips.

John xviii. 11.
Luke xxii. 20.

6 The Lord himself is the portion of mine inheritance, and of my cup : thou shalt maintain my lot.

7 The lot is fallen unto me in a fair ground : yea, I have a goodly heritage.

Isa. liii. 11.

8 I will thank the Lord for giving me warning : my reins also chasten me in the night-season.

Acts ii. 25.

9 I have set God always before me : for he is on my right hand, therefore I shall not fall.

Acts ii. 26.
Isa. xxvi. 16.

10 Wherefore my heart was glad, and my glory rejoiced : my flesh also shall rest in hope.

Acts ii. 27.
xiii. 35.

11 For why? thou shalt not leave my soul in hell : neither shalt thou suffer thy Holy One to see corruption.

Acts ii. 28.

12 Thou shalt shew me the path of life ; in thy presence is the fulness of joy : and at thy right hand there is pleasure for evermore.

THE XVII PSALM.

Exaudi, Domine.

HEAR the right, O Lord, consider my complaint : and hear-

PSALMUS XV.

CONSERVA me Domine, quoniam speravi in te : dixi Domino, Deus meus es tu, quoniam bonorum meorum non eges.

Sunday, Martyrs,
Mattins,
2nd Noct.
Easter Eve,
1st Noct.

indiges

Sanctis qui sunt in terra ejus : mirificavit omnes voluntates meas in eis.

inter illos

Multiplicatae sunt infirmitates eorum : postea acceleraverunt.

Non congregabo conventicula eorum de sanguinibus : nec memor ero nominum eorum per labia mea.

Dominus pars hereditatis meae, et calicis mei : tu es qui restitues hereditatem meam mihi.

restituisi mihi

Funes ceciderunt mihi in praecularis : etenim hereditas mea praecleara est mihi.

Benedicam Dominum, qui tribuit mihi intellectum : insuper et usque ad noctem increpauerunt me renes mei.

increpauerunt

Providebam Dominum in conspectu meo semper : quoniam a dextris est mihi ne commovear.

Propter hoc letatum est cor meum, et exultavit lingua mea : insuper et caro mea requiescet in spe.

delectatum

Quoniam non derelinques animam meam in inferno : nec dabis sanctum tuum videre corruptionem.

Notas mihi fecisti vias vitae : adimplebis me laetitia cum vultu tuo ; delectationes in dextera tua usque in finem.

PSALMUS XVI.

EXAUDI Domine justitiam meam : intende deprecationem meam.

Sunday Mattins.
2nd Noct.

PSALM XVI.

The first words spoken by St. Peter after Christ had given him to understand what was written in the Psalms concerning Him, and when inspired by the Holy Ghost at Pentecost, gave the proper interpretation of this Psalm, showing that it was spoken, prophetically, in the person of Christ, and not of David, to whom the latter portion could have no real application. The same interpretation of the Psalm was also given by St. Paul in his first public ministration after the Holy Ghost had said, "Separate me Barnabas and Saul for the work whereunto I have called them." Although, therefore, the former half of the Psalm may be accommodated to the Church and to individual members of it,

the primary interpretation of the whole must be understood to be of Christ Himself. Its use on Easter Eve by the ancient Church of England shows also that this interpretation was adopted by it in the commemoration of our Lord's Rest and Resurrection.

The first part of the Psalm appears to refer to the offering which Christ made for an atonement between God and man. God needed not even the "goods" of this sacrifice, for He is perfect in Himself even without the salvation of mankind. But Christ's delight was in those whom He was saving by His sacrifice ; and as He had come to do His Father's will, so would He magnify His will in them, that God's will might be done on earth as it is in Heaven. For them Christ will be a continual Intercessor, but the offerings of those who run after another

The III. Day.
Morning
Prayer.

John xix. 11.

ken unto my prayer, that goeth not out of feigned lips.

2 Let my sentence come forth from thy presence : and let thine eyes look upon the thing that is equal.

Luke xxiii. 4.
xxiii. 14, 15.
41. 47.
1 Pet. ii. 22.

3 Thou hast proved and visited mine heart in the night-season ; thou hast tried me, and shalt find no wickedness in me : for I am utterly purposed, that my mouth shall not offend.

4 Because of men's works, that are done against the words of thy lips : I have kept me from the ways of the destroyer.

5 O hold thou up my goings in thy paths : that my footsteps slip not.

6 I have called upon thee, O God, for thou shalt hear me : incline thine ear to me, and hearken unto my words.

7 Shew thy marvellous loving-kindness, thou that art the Saviour of them which put their trust in thee : from such as resist thy right hand.

8 Keep me as the apple of an eye : hide me under the shadow of thy wings.

John x. 24.
Luke xxiii. 1.

9 From the ungodly, that trouble me : mine enemies compass me round about to take away my soul.

1 Sam. ii. 15.

10 They are inclosed in their own fat : and their mouth speaketh proud things.

11 They lie waiting in our way on every side : turning their eyes down to the ground.

12 Like as a lion that is greedy of his prey : and as it were a lion's whelp, lurking in secret places.

13 Up, Lord, disappoint him, and cast him down : deliver my soul from the ungodly, which is a sword of thine.

Auribus percipe orationem meam : non in labiis dolosis.

De vultu tuo iudicium meum prodeat : oculi tui videant æquitates.

æquitatem

Probasti cor meum, et visitasti nocte : igne me examinasti, et non est inventa in me iniquitas.

Ut non loquatur os meum opera hominum : propter verba labiorum tuorum ego custodivi vias duras.

Perfice gressus meos in semitis tuis : ut non moveantur vestigia mea.

Ego clamavi, quoniam exaudisti me Deus : inclina aurem tuam mihi, et exaudi verba mea.

Mirifica misericordias tuas : qui salvos facis sperantes in te.

A resistentibus dexteræ tuæ custodi me : ut pupillam oculi.

Domine ut pupillum

Sub umbra alarum tuarum protege me : a facie impiorum qui me affixerunt.

Inimici mei animam meam circumdederunt, adipem suum concluserunt : os eorum locutum est superbiam.

in superbia

Projicientes me nunc circumdederunt me : oculos suos statuerunt declinare in terram.

Susceperunt me sicut leo paratus ad prædam : et sicut catulus leonis habitans in abditis.

Exsurge Domine, præveni eum, et supplantata eum : eripe animam meam ab impio, frameam tuam ab inimicis manus tuæ.

eos . . . eos

inimicorum de manu tua

god will not be united to His perpetual Intercession, will be no re-presentation of His Sacrifice.

In association with the sixth verse we cannot fail to remember, first, the Cup of our Lord's sufferings ; and, secondly, the Cup of the New Testament in His Blood.

PSALM XVII.

There are words in this Psalm which can only be used in their complete sense of the Son of Man. Of Him Pilate said, "I have found no fault in Him ;" his wife, "This just Person ;" the thief on the cross, "This man hath done nothing amiss ;" the centurion, "Certainly this was a righteous man ;" and His disciple

and companion, St. Peter, that He "did no sin, neither was guile found in His mouth." Of no other man, however holy, could it be truly said, "Thou shalt find no wickedness in me ;" and as the whole Psalm is compactly connected together, we must conclude that it is all written of Him respecting Whom alone these words can be written.

The frequent references to our Lord's Passion which occur in the Psalms are in exact keeping with His conversation while on earth, and with the character of that perpetual Memorial of His Death which He instituted as the Key-stone of the New Temple, and the guide to the Church's religious habits. With His disciples He continually discoursed about His coming Passion ; to

The III. Day.
Morning
Prayer.

14 From the men of, thy hand, O Lord, from the men, I say, and from the evil world : which have their portion in this life, whose bellies thou fillest with thy hid treasure.

15 They have children at their desire : and leave the rest of their substance for their babes.

16 But as for me, I will behold thy presence in righteousness : and when I awake up after thy likeness, I shall be satisfied with it.

Rev. xxii. 4.
Heb. i. 3.
1 Cor. xv. 49.
Rom. vi. 5.

THE XVIII PSALM.

Diligam te, Domine.

Evening
Prayer.
Matt. xvi. 18.
1 Cor. x. 4.
Heb. ii. 13.
Luke i. 69.

I WILL love thee, O Lord, my strength; the Lord is my stony rock, and my defence : my Saviour, my God, and my might, in whom I will trust, my buckler, the horn also of my salvation, and my refuge.

2 I will call upon the Lord, which is worthy to be praised : so shall I be safe from mine enemies.

3 The sorrows of death compassed me : and the overflowings of ungodliness made me afraid.

4 The pains of hell came about me : the snares of death overtook me.

5 In my trouble I will call upon the Lord : and complain unto my God.

Matt. xxvi. 38.
xxvii. 46.

Domine a paucis de terra divide eos in vita eorum : de absconditis tuis adimpletus est venter eorum.

*dispertire eos et
supplanta eos
in vita ipsorum*

Saturati sunt filiis : et dimiserunt reliquias suas parvulis suis.

*Sat. sunt porcina
et reliquerunt
quæ superfluerunt
parv. suis*

Ego autem in justitia apparebo in conspectui tuo : satiabor cum appa-

dum manifestabitur

ruerit gloria tua.

PSALMUS XVII.

DILIGAM te Domine fortitudo mea : Dominus firmamentum meum, et refugium meum, et liberator meus.

*Sunday Mattins.
2nd Noct.*

Deus meus adjutor meus : et sperabo in eum.

Protector meus, et cornu salutis meæ : et susceptor meus.

virtus mea

adjutor meus

Laudans invocabo Dominum : et ab inimicis meis salvus ero.

Circumdederunt me dolores mortis : et torrentes iniquitatis conturbaverunt me.

me gemitus mortis

Dolores inferni circumdederunt me : præoccupaverunt me laquei mortis.

prævenērunt me

the multitude He also spoke of His "lifting up;" and when Moses and Elias came to Him from the unseen world, they talked with Him concerning His decease that He should accomplish at Jerusalem. Nor is this to be wondered at, when it is considered that the Death of Christ was the central point of all the world's spiritual history, that to which the ages preceding looked forward, that to which all following ages look back.

Of the Lord's atoning work, therefore, the Church is inspired to sing more than of any other theme, and Psalm after Psalm is occupied with references to it; references once prophetic, now historical, but one continuous present to the Holy Ghost Who inspired them.

The Psalm may be taken in detail as a prayer of the holy Jesus when He was going from Gethsemane to the High Priest's house, to the hall of Pilate, and to Calvary. The Righteous One condemned by unjust human judges appeals to the Divine and unerring Judge for declaration of His innocence; and it may be that the words of Pilate and others were an answer to this prayer. The world says, "Let Him be crucified," but God has already said, "This is My Beloved Son in Whom I am well pleased," and even unrighteous judges cannot gainsay the Divine sentence. Even the accusation, "This is the King of the Jews," was turned into truth against the will of Pilate and the chief priests, so that the former was obliged to say, "What I have written, I have written."

In the concluding verses there is a contrast between the inheritance of this world, and that of Christ's spiritual Kingdom. The natural cry was, "Who shall declare His generation, for He is

cut off from the land of the living?" for He seemed to die and to leave neither children nor substance. But "He beheld of the travail of His soul and was satisfied," for He beheld to utmost ages the reign of His glorious Kingdom, and that of Himself the whole family in Heaven and in earth should be named.

PSALM XVIII.

This triumphal hymn is found also in the twenty-second chapter of the Second Book of Samuel, where it is described as the song which David spake "in the day when the Lord delivered him out of the hand of all his enemies, and out of the hand of Saul." But, as in all the songs of "the man who was raised up on high, the anointed of the God of Jacob, and the sweet Psalmist of Israel, the Spirit of the Lord spake by him, and His word was in his tongue," and a far higher and deeper meaning is evident than can belong to David himself, or to any circumstances of sorrow or victory in which he was ever placed. The sorrows are too deep for any but the Man of Sorrows, the triumph too exultant for any but "the Root of Jesse, and He that shall rise to reign over the Gentiles." [Rom. xv. 12.]

1 This remarkable reading arises, seemingly, from a confusion between the words *vivon* and *viéon*, in the LXX. It received a ready acquiescence probably from the fact that swine's flesh was an unlawful food to the Jews, and partaking of it would be an illustration of their wilful disobedience and wickedness. The tenth and fourteenth verses also seem to give some countenance to it, referring apparently to the fat of the sacrifices which could not lawfully be eaten, and to the sensual, selfish lives of the Jews.

The III. Day.

*Evening**Prayer.*Heb. v. 7.
Mark xv. 38.
al. "enter even
into."Matt. xxvii. 51.
Heb. xii. 27.

6 So shall he hear my voice out of his holy temple : and my complaint shall come before him, it shall enter into his ears.

7 The earth trembled and quaked : the very foundations also of the hills shook, and were removed, because he was wroth.

8 There went a smoke out in his presence : and a consuming fire out of his mouth, so that coals were kindled at it.

9 He bowed the heavens also, and came down : and it was dark under his feet.

10 He rode upon the cherubims, and did fly : he came flying upon the wings of the wind.

11 He made darkness his secret place : his pavilion round about him with dark water, and thick clouds to cover him.

12 At the brightness of his presence his clouds removed : hail-stones, and coals of fire.

13 The Lord also thundered out of heaven, and the Highest gave his thunder : hail-stones, and coals of fire.

14 He sent out his arrows, and scattered them : he cast forth lightnings, and destroyed them.

15 The springs of waters were seen, and the foundations of the round world were discovered at thy chiding, O Lord : at the blasting of the breath of thy displeasure.

16 He shall send down from on high to fetch me : and shall take me out of many waters.

17 He shall deliver me from my strongest enemy, and from them which hate me : for they are too mighty for me.

18 They prevented me in the day of my trouble : but the Lord was my upholder.

In tribulatione mea invocavi Dominum : et ad Deum meum clamavi :

Et exaudivit de templo sancto suo vocem meam : et clamor meus in conspectu ejus introivit in aures ejus.

Commota est et contremuit terra : fundamenta montium conturbata sunt, et commota sunt, quoniam iratus est eis.

eis Deus

Ascendit fumus in ira ejus, et ignis a facie ejus exarsit : carbones succensi sunt ab eo.

exarsit

Inclinavit celos, et descendit : et caligo sub pedibus ejus.

Et ascendit super Cherubin, et volavit : volavit super pennas ventorum.

Et posuit tenebras latibulum suum, in circuitu ejus : tabernaculum ejus, tenebrosa aqua in nubibus aeris.

Præ fulgore in conspectu ejus nubes transierunt : grando et carbones ignis.

Et intonuit de cælo Dominus, et Altissimus dedit vocem suam : grando et carbones ignis,

vocem suam: misit sagittas

Et misit sagittas suas, et dissipavit eos : fulgura multiplicavit, et conturbavit eos.

Et apparuerunt fontes aquarum : et revelata sunt fundamenta orbis terrarum.

Ab increpatione tua, Domine : ab inspiratione spiritus iræ tuæ.

ab increpatione spiritus

Misit de summo, et accepit me : et assumpsit me de aquis multis.

de multitudine aquarum

Eripuit me de inimicis meis fortissimis, et ab his qui oderunt me : quoniam confortati sunt super me.

Prævenerunt me in die afflictionis meæ : et factus est Dominus protector meus.

1 Kings ix. 12.
Matt. xxvii. 45.

Exod. ix. 23.

Gen. vii. 11.
Zech. xiii. 1.

Rev. xi. 13.

Passing by, then, the historical application of this Psalm of victory to the person of David, we may trace out its prophetic and mystical application to the Person of Christ. The opening words of it are an indication that the Son of man is speaking in His human nature, and speaking of the Divine Nature Which is its Strength, its Rock of ages, its Defence, its Saviour, its God, its Buckler, the Horn also of its Salvation, and its Refuge. And

as Christ thus looks upward from the depths of His humiliation to His Divine Nature in its glory, so the Church may look to Christ and say all these words of Him, the Rock upon which she is so founded, that the gates of Hell cannot prevail against her.

After this opening ascription of praise the Psalm descends into the deeps of the Passion ; in which the sorrows of death encompassed the body of the Crucified, and the overflowings of that

The III. Day.
Evening
Prayer.
Rev. xxi. 4.

19 He brought me forth also into a place of liberty : he brought me forth, even because he had a favour unto me.

Rev. v. 9. ii. 26.

20 The Lord shall reward me after my righteous dealing : according to the cleanness of my hands shall he recompense me.

21 Because I have kept the ways of the Lord : and have not forsaken my God, as the wicked doth.

22 For I have an eye unto all his laws : and will not cast out his commandments from me.

23 I was also uncorrupt before him : and eschewed mine own wickedness.

24 Therefore shall the Lord reward me after my righteous dealing : and according unto the cleanness of my hands in his eye-sight.

John xv. 4.

25 With the holy thou shalt be holy : and with a perfect man thou shalt be perfect.

Rev. xxii. 11.

26 With the clean thou shalt be clean : and with the froward thou shalt learn frowardness.

27 For thou shalt save the people that are in adversity : and shalt bring down the high looks of the proud.

Rev. xxi. 25.

28 Thou also shalt light my candle : the Lord my God shall make my darkness to be light.

29 For in thee I shall discomfit an host of men : and with the help of my God I shall leap over the wall.

Rev. xv. 3.
John xiv. 6.
Dan. iii. 25.

30 The way of God is an undefiled way : the word of the Lord also is tried in the fire ; he is the defender of all them that put their trust in him.

31 For who is God, but the Lord : or who hath any strength, except our God ?

32 It is God, that girdeth me with strength of war : and maketh my way perfect.

Et eduxit me in latitudinem : sal-
vum me fecit, quoniam voluit me.

Et retribuet mihi Dominus secun-
dum justitiam meam : et secundum
puritatem manuum mearum retribuet
mihi.

Quia custodivi vias Domini : nec
impie gessi a Deo meo.

Quoniam omnia judicia ejus in con-
spectu meo : et justitias ejus non re-
puli a me.

Et ero immaculatus cum eo : et ob-
servabo me ab iniquitate mea. conspectu meo
sunt semper

Et retribuet mihi Dominus secun-
dum justitiam meam : et secundum coram eo
puritatem manuum mearum in con-
spectu oculorum ejus.

Cum sancto sanctus eris : et cum
viro innocente innocens eris :

Et cum electo electus eris : et cum
perverso perverteris.

Quoniam tu populum humilem sal-
vum facies : et oculos superborum
humiliabis. subverteris

Quoniam tu illuminas lucernam
meam, Domine : Deus meus, illumina
tenebras meas.

Quoniam in te eripiar a tentatione :
et in Deo meo transgrediar murum.

Deus meus impolluta via ejus : elo-
quia Domini igne examinata ; pro-
a te
tector est omnium sperantium in se.

Quoniam quis Deus præter Domi-
num : aut quis Deus præter Deum
nostrum ?

Deus qui præcinxit me virtute : et
posuit immaculatam viam meam.

ingodliness which He bore in His soul when He was made sin for us, caused Him to cry out in His trouble as if in fear, "My God, My God, why hast Thou forsaken Me?" In what manner the bitter pain of this trouble was assuaged we know not, but that some immediate evidence was given of His voice having reached from the cross to God's holy temple is shown by the peaceful contrast of the words in which Christ commended His

soul to His Father. Nor may it be forgotten that the prevailing power of the great Sacrifice was heard for all mankind when the answer of God went forth from the Holy of Holies by the miraculous rending of the veil from the top to the bottom.

From the seventh verse forward there is a reference to the foundation of the old dispensation on Sinai as a type of that breaking up of all old foundations which ensued when all things

The III. Day.
Evening
Prayer.
Habak. iii. 19.

33 He maketh my feet like harts' feet : and setteth me up on high.

34 He teacheth mine hands to fight : and mine arms shall break even a bow of steel.

Heb. v. 8.
Phil. ii. 8, 9.

35 Thou hast given me the defence of thy salvation : thy right hand also shall hold me up, and thy loving correction shall make me great.

36 Thou shalt make room enough under me for to go : that my footsteps shall not slide.

Rev. xix. 11.

37 I will follow upon mine enemies, and overtake them : neither will I turn again till I have destroyed them.

38 I will smite them, that they shall not be able to stand : but fall under my feet.

Rev. xix. 13.
Eph. vi. 10.

39 Thou hast girded me with strength unto the battle : thou shalt throw down mine enemies under me.

40 Thou hast made mine enemies also to turn their backs upon me : and I shall destroy them that hate me.

Rev. xix. 21.

41 They shall cry, but there shall be none to help them : yea, even unto the Lord shall they cry, but he shall not hear them.

42 I will beat them as small as the dust before the wind : I will cast them out as the clay in the streets.

43 Thou shalt deliver me from the strivings of the people : and thou shalt make me the head of the heathen.

Luke ii. 32.

44 A people whom I have not known : shall serve me.

Acts xxviii. 23.

45 As soon as they hear of me they shall obey me : but the strange children shall dissemble with me.

• Qui perfecit pedes meos tanquam cervorum : et super excelsa statuens *statuit* me.

Qui docet manus meas ad prælium : et posuisti ut arcum æreum brachia *posuit* mea.

Et dedisti mihi protectionem salutis tuæ : et dextera tua suscepit me : *suscipit me : et disciplina tua ipsa me docebit.*
Et disciplina tua correxit me in finem : et disciplina tua, ipsa me docebit.

Dilatasti gressus meos subtus me : et non sunt infirmata vestigia mea.

Persequar inimicos meos, et comprehendam illos : et non convertar donec deficiant.

Confringam illos, nec poterunt *Adfringam* stare : cadent subtus pedes meos.

Et præcinxisti me virtute ad bellum : et supplantasti insurgentes in me subtus me.

Et inimicos meos dedisti mihi dorsum : et odientes me disperdidisti. *inimicorum meorum*

Clamaverunt, nec erat qui salvos faceret : ad Dominum, nec exaudivit eos.

Et comminuam eos ut pulverem ante faciem venti : ut lutum platearum delebo eos.

Eripies me de contradictionibus populi : constitues me in caput gentium.

Populus quem non cognovi servivit mihi : in auditu auris obedivit mihi. *obaudivit*

were made new in the Church of Christ. For the literal earthquake at the crucifixion was the precursor of that "Yet once more I shake not the earth only, but also heaven" [Heb. xii. 26], by which the "kingdom that cannot be moved" was to be established : even as the latter is a precursor of that second Advent in which all things will be dissolved to the end that they may be remoulded into a new Heaven and a new Earth. In this imagery all the means by which God has brought salvation and peace out of turmoil and destruction are referred to ; and hence the foundations of the world being discovered through the springs of waters prefigure the regeneration of the world by water as the former verses had spoken of its regeneration by fire ; both typical of the great work of its new birth by the miracle of the Incarnation. Thus the Psalm throughout may be interpreted of Christ.

And thus we are also guided to the sense in which this Psalm is the voice of the Church, because it is the voice of her Head. St. Paul speaks often of the fellowship which the members of Christ have in His sufferings ; and even of filling "up that which is behind of the afflictions of Christ" in his own flesh [Col. i. 24]. So there is scarcely any verse of this Psalm which may not be sung as the words of the mystical body of our Lord, whether they are words of sorrow or of victory. The key to such an use of it is to be found in the words of the prophet, "O thou afflicted, tossed with tempest, and not comforted, behold, I will lay thy stones with fair colours, and lay thy foundations with sapphires. And I will make thy windows of agates, and thy gates of carbuncles, and all thy borders of pleasant stones. And all thy children shall be taught of the Lord : and great shall be the peace of thy children. In righteousness shalt thou be estab-

The III. Day. Evening Prayer. Exod. iii. 14. John vi. 57, 58. v. 26. xiv. 19.

46 The strange children shall fail : and be afraid out of their prisons.

47 The Lord liveth, and blessed be my strong helper : and praised be the God of my salvation.

48 Even the God, that seeth that I be avenged : and subdueth the people unto me.

49 It is he, that delivereth me from my cruel enemies, and setteth me up above mine adversaries : thou shalt rid me from the wicked man.

Rom. xv. 9. 50 For this cause will I give thanks unto thee, O Lord, among the Gentiles : and sing praises unto thy Name.

Ezek. xxxiv. 22. Zech. xii. 8. Isa. liiii. 10.

51 Great prosperity giveth he unto his King : and sheweth loving-kindness unto David his Anointed, and unto his seed for evermore.

THE XIX PSALM.

Cœli enarrant.

The IV. Day. Morning Prayer. Christmas Matins.

THE heavens declare the glory of God : and the firmament sheweth his handy-work.

2 One day telleth another : and one night certifieth another.

3 There is neither speech, nor language : but their voices are heard among them.

Rom. x. 18. 4 Their sound is gone out into all lands : and their words into the ends of the world.

Mal. iv. 2. John viii. 12. Rev. iv. 3. xxi. 23.

5 In them hath he set a tabernacle for the sun : which cometh forth as a bridegroom out of his chamber, and rejoiceth as a giant to run his course.

Filii alieni mentiti sunt mihi : filii alieni inveterati sunt, et claudicaverunt a semitis suis. *inveteraverunt*

Vivit Dominus, et benedictus Deus meus : et exaltetur Deus salutis meæ.

Deus qui das vindictas mihi, et subdis populos sub me : liberator meus de inimicis meis iracundis. *subdidi lib. meus Dominus de gentibus iracundis*

Et ab insurgentibus in me exaltabis me : a viro iniquo eripies me.

Propterea confitebor tibi in nationibus, Domine : et nomini tuo psalmum dicam. *populis*

Magnificans salutes Regis ejus, et faciens misericordiam Christo suo David : et semini ejus usque in sæculum. *salutare regis ipsius*

PSALMUS XVIII.

CŒLI enarrant gloriam Dei : et opera manuum ejus annuntiat firmamentum. *Sunday Matins. 3rd Noct. Christmas, Circumc., Ascensiontide, Trinity Sund., App. Evv., and B. V. M. 1st Noct. St. Michael, All Saints, 2nd Noct.*

Dies diei eructat verbum : et nox nocti indicat scientiam.

Non sunt loquelæ, neque sermones : quorum non audiantur voces eorum.

In omnem terram exivit sonus eorum : et in fines orbis terræ verba eorum.

In sole posuit tabernaculum suum : et ipse tanquam sponsus procedens de thalamo suo.

lished" [Isa. liv. 11—14]. For the prosperity which God giveth unto the King Whom He hath set in His holy hill of Zion He extends also to "His seed for evermore," even to that Church of the redeemed of whom the Redeemer says continually, "Behold I and the children whom Thou hast given Me."

PSALM XIX.

The ancient Church of England appears to have regarded this Psalm as one which especially set forth the glory of Christ in the Communion of Saints: and by its appropriation to Festivals of the Incarnation, of the Apostles, the holy Angels, and All Saints, to have illustrated the words of St. Paul: "Ye are come unto Mount Zion, and unto the City of the living God, the heavenly Jerusalem, and to an innumerable company of angels, to the general assembly and church of the First-born which are written in heaven, and to God the Judge of all, and to the spirits of just men made perfect, and to Jesus the Mediator of the New Covenant." [Heb. xii. 22—24.]

The key to this application of the Psalm is given by St. Paul in Rom. x. 18, where he takes the fourth verse as a prophecy of the foundation of the Church by the Apostles and Evangelists. But it may also be drawn from a comparison of the Psalm with other words of the Holy Ghost and of Christ Himself.

The central idea of the Psalm is contained in the fifth and sixth verses, the previous portion leading up to these, and that which follows taking its cue from them. In these two verses the mind of the Church has always observed a prophecy of "the Sun of righteousness" which it was declared should "arise with healing in His beams" [Mal. iv. 2]: a prophecy, that is, of Him Who said, "I am the Light of the world" [John viii. 12]; of Whom St. John wrote that He was the true Light coming into the world to illuminate all men [Ibid. i. 9]; and Who in after years said also of Himself, "I am the root and the offspring of David, and the bright and morning Star." [Rev. xxii. 16.]

The heavens therefore declare the glory of God as a mystical parable of the spiritual world. Christ is the central luminary

The IV. Day.
*Morning
Prayer.*

6 It goeth forth from the uttermost part of the heaven, and runneth about unto the end of it again : and there is nothing hid from the heat thereof.

Matt. xi. 25.

7 The law of the Lord is an undefiled law, converting the soul : the testimony of the Lord is sure, and giveth wisdom unto the simple.

8 The statutes of the Lord are right, and rejoice the heart : the commandment of the Lord is pure, and giveth light unto the eyes.

Matt. v. 8.

John viii. 16.
Rev. xvi. 5. 7.

9 The fear of the Lord is clean, and endureth for ever : the judgements of the Lord are true, and righteous altogether.

Ezek. iii. 3.
Rev. x. 9.

10 More to be desired are they than gold, yea, than much fine gold : sweeter also than honey, and the honeycomb.

Matt. v. 12.
Rev. xi. 18.

11 Moreover, by them is thy servant taught : and in keeping of them there is great reward.

12 Who can tell how oft he offendeth : O cleanse thou me from my secret faults.

13 Keep thy servant also from presumptuous sins, lest they get the dominion over me : so shall I be undefiled, and innocent from the great offence.

14 Let the words of my mouth, and the meditation of my heart : be alway acceptable in thy sight,

15 O Lord : my strength, and my redeemer.

THE XX PSALM.

Exaudiat te Dominus.

Royal Accession.
John xii. 27.

THE Lord hear thee in the day of trouble : the Name of the God of Jacob defend thee ;

Exsultavit ut gigas ad currendam viam : a summo cœlo egressio ejus :

Et occursus ejus usque ad summum ejus : nec est qui se abscondat a calore ejus.

Lex Domini immaculata, convertens inreprehensibilis animas : testimonium Domini fidele, sapientiam præstans parvulis.

Justitiæ Domini rectæ, lætificantes corda : præceptum Domini lucidum, illuminans oculos.

Timor Domini sanctus ; permanet in sæculum sæculi : judicia Domini vera, justificata in semetipsa.

Desiderabilia super aurum et lapidem pretiosum multum : et dulciora super mel et favum.

Etenim servus tuus custodit ea : in nam et . . . in custodiendo illa custodiendis illis retributio multa.

Delicta quis intelligit ? ab occultis meis munda me : et ab alienis parce munda me Domine servo tuo.

Si mei non fuerint dominati, tunc immaculatus ero : et emundabor a delicto maximo.

Et erunt ut complacent eloquia oris mei : et meditatio cordis mei in conspectu tuo semper.

Domine, adjutor meus : et redemptor meus.

PSALMUS XIX.

EXAUDIAT te Dominus in die Sunday Mattins.
3rd Noct. tribulationis : protegat te Nomen Dei Jacob.

from Whom flows all the Light, heat, and Life by which souls live and the glory of God is promoted. As in the glorified City of God, so in the Church Militant, "the Lamb is the Light thereof," and she beholds His glory, the glory of the only begotten of the Father, full of grace and truth, a glory transfiguring the flesh in which He dwelt [*ἐσκήνωσε* = tabernacled, John i. 14] among His people. From Him flowed the light of grace and truth to the Apostles. As He had said of Himself, so He said of them, "Ye are the light of the world" and, "As the Father hath sent Me, so send I you." And thus "one day telleth another," and the sound of the glorious message of the Incarnation has gone out into all lands through the ministration of the Church, so that nothing is hid from the heat of the vivifying Sun of Righteous-

ness. Thus also Christ is in His Church, vivifying all its work and its members,—"in them hath He set a tabernacle for the Sun:" and again the heavens declare the glory of God when they enable the seer to say, "I heard a great voice from heaven saying, Behold, the tabernacle of God is with men, and He will dwell with them, and they shall be His people, and God Himself shall be with them and be their God." [Rev. xxi. 3.]

The latter verses are to be taken as an expansion of the concluding words of the sixth, "there is nothing hid from the heat thereof." For this all-embracing Light is law, testimony, statute, commandment, fear, and judgment; converting, giving wisdom, joy, purity, everlasting life, and perfect righteousness: a savour of life unto life, or a savour of death unto death.

The IV. Day.
Morning
Prayer.

2 Send thee help from the sanctuary : and strengthen thee out of Sion ;

3 Remember all thy offerings : and accept thy burnt-sacrifice ;

John xvii. 21.

4 Grant thee thy heart's desire : and fulfil all thy mind.

5 We will rejoice in thy salvation, and triumph in the Name of the Lord our God : the Lord perform all thy petitions.

Matt. xxvii. 43.

6 Now know I, that the Lord helpeth his Anointed, and will hear him from his holy heaven : even with the wholesome strength of his right hand.

Deut. xvii. 16.

7 Some put their trust in chariots, and some in horses : but we will remember the Name of the Lord our God.

8 They are brought down, and fallen : but we are risen, and stand upright.

Matt. xxi. 9.

9 Save, Lord, and hear us, O King of heaven : when we call upon thee.

THE XXI PSALM.

Domine, in virtute tua.

Ascension Day
Matt., Royal
Accession.
Windsor Obiit
Sunday.
Isa. xxxii. 1.
Rev. iv. 2. 11.
John xvii. 24.

THE King shall rejoice in thy strength, O Lord : exceeding glad shall he be of thy salvation.

2 Thou hast given him his heart's desire : and hast not denied him the request of his lips.

Mittat tibi auxilium de sancto : et de Sion tueatur te.

Memor sit omnis sacrificii tui : et holocaustum tuum pingue fiat. *sit Dominus*

Tribuat tibi secundum cor tuum : et omne consilium tuum confirmet. *tibi Dominus*

Lætabimur in salutari tuo : et in nomine Dei nostri magnificabimur. *Domini Dei*

Impleat Dominus omnes petitiones tuas : nunc cognovi quoniam salvum fecit Dominus Christum suum.

Exaudiet illum de cælo sancto suo : in potentatibus salus dexteræ ejus.

Hi in curribus, et hi in equis : nos autem in nomine Domini Dei nostri invocabimus. *magnificabimur*

Ipsi obligati sunt, et ceciderunt, nos autem surreximus et erecti sumus. *nos vero resurreximus et*

Domine salvum fac regem : et exaudi nos in die qua invocaverimus te.

PSALMUS XX.

DOMINE in virtute tua lætabitur rex : et super salutare tuum exultabit vehementer. *Sunday, Martyrs, Mattins, 3rd Noct.*

Desiderium cordis ejus tribuisti ei : et voluntate labiorum ejus non fraudasti eum. *Desiderium anime*

"The nations of them which are saved shall walk in the light of it." [Rev. xxi. 24.] And to them it shall be a cleansing, purifying Light. Others there will be to whom it will be a Light of true and righteous judgment, "scorching them with great heat" [Rev. xvi. 9], and bringing to light all their hidden works of darkness.

With this Psalm therefore should ever go up a prayer that the work of Christ's Incarnation may go forward more and more in the world at large and in every heart, so that He may be the everlasting Light of us and of all whom He has redeemed.

PSALM XX.

The original purpose of this Psalm was doubtless of a similar kind to that for which it has been chosen in modern-times as a proper Psalm for the day of the Sovereign's accession to the throne. But in its full meaning it looks beyond all earthly sovereigns to Him Who is in the most true and complete sense the Anointed of the Lord.

And it is to be remarked that the words throughout are an illustration of the manner in which Christ is pleased to identify Himself with His mystical Body ; so that the Church joins herself with Him in His very intercession for her members. Christ says, "Do this in remembrance of Me," and while the Church obeys His command and offers a constant Memorial before God of the Sacrifice of Christ, she yet places that Memorial in His

hands, saying, May God remember all *Thy* offerings ; grant Thee Thy heart's desire, which is that all may have the benefit of Thine offering and rejoice in Thy salvation. There was a type of this in Christ's words to His Three Apostles, "What, could ye not watch with Me one hour ?" and there is a parable of it in the Revelation, where "the Lamb as it had been slain" stands in continual intercession before the Throne, yet in the midst of the four and twenty elders.

The last verse is constantly used in the suffrages of Morning and Evening Prayer according to the form in which it appears in the LXX and the Vulgate. The two readings show the lower and the higher application of the Psalm, the English being equivalent to the "Hosanna to the Son of David" with which Christ was led in triumph to Jerusalem.

PSALM XXI.

Whatever was the original purpose of this song of triumph, the coming of Christ to His Kingdom has given it a meaning before which all lower ones must fade into distance. Its position as a proper Psalm for Ascension Day points out therefore the proper interpretation to be given to it at all times, as a Psalm which magnifies the Son of Man seated on the Throne of His Divine glory.

In such words the Church on earth echoes the strains of those who "cast their crowns before the Throne, saying, Thou art

The IV. Day.
Morning
Prayer.
Heb. ii. 9.
Rev. xix. 12.

3 For thou shalt prevent him with the blessings of goodness : and shalt set a crown of pure gold upon his head.

Rev. iv. 9.
xi. 15.

4 He asked life of thee, and thou gavest him a long life : even for ever and ever.

Isa. xl. 5.
Phil. ii. 9, 10.

5 His honour is great in thy salvation : glory, and great worship shalt thou lay upon him.

6 For thou shalt give him everlasting felicity : and make him glad with the joy of thy countenance.

Heb. xii. 2.

7 And why? because the King putteth his trust in the Lord : and in the mercy of the most Highest he shall not miscarry.

8 All thine enemies shall feel thy hand : thy right hand shall find out them that hate thee.

Rev. xi. 18.

9 Thou shalt make them like a fiery oven in time of thy wrath : the Lord shall destroy them in his displeasure, and the fire shall consume them.

Matt. xxvii. 25.

10 Their fruit shalt thou root out of the earth : and their seed from among the children of men.

11 For they intended mischief against thee : and imagined such a device as they are not able to perform.

12 Therefore shalt thou put them to flight : and the strings of thy bow shalt thou make ready against the face of them.

John xvii. 5.
Rev. xi. 17.

13 Be thou exalted, Lord, in thine own strength : so will we sing, and praise thy power.

THE XXII PSALM.

Deus, Deus meus.

Evening
Prayer.
Good Friday,
Mattins.
A Passion
Psalm.
Matt. xxvii. 46.
Isa. liv. 7.

MY God, my God, look upon me ; why hast thou forsaken me : and art so far from my health, and from the words of my complaint?

Quoniam prævenisti eum in benedictionibus dulcedinis : posuisti in capite ejus coronam de lapide pretioso.

Vitam petiit a te, et tribuisti ei : longitudinem dierum in sæculum, et in sæculum sæculi.

Magna est gloria ejus in salutari tuo : gloriam et magnum decorem impones super eum.

Quoniam dabis eum in benedictionem in sæculum sæculi : lætificabis eum in gaudio cum vultu tuo.

Quoniam rex sperat in Domino : et in misericordia Altissimi non commovebitur.

Inveniatur manus tua omnibus inimicis tuis : dextera tua inveniatur omnes qui te oderunt.

Pones eos ut clibanum ignis in tempore vultus tui : Dominus in ira sua conturbabit eos, et devorabit eos ignis.

Fructum eorum de terra perdes : et semen eorum a filiis hominum.

Quoniam declinaverunt in te mala : cogitaverunt consilia, quæ non poterunt stabilire.

Quoniam pones eos dorsum : in reliquiis tuis præparabis vultum eorum.

Exaltare Domine in virtute tua : cantabimus et psallemus virtutes tuas.

PSALMUS XXI.

DEUS Deus meus, respice in me, quare me dereliquisti? longe a salute mea verba delictorum meorum.

worthy, O Lord, to receive glory, and honour, and power;" remembering the "Author and Finisher of our faith, Who for the joy that was set before Him endured the Cross, despising the shame, and is set down at the right hand of the Throne of God."

The heart's desire of Christ was, that all might be redeemed and reign with Him as kings and priests in His glorified kingdom. And when He prayed unto Him that was able to save Him from death, that if it were possible the cup might pass from Him, He was heard in that He feared, and offered the perfect obedience of "not My will but Thine." And so, although the King was to wear a crown of thorns, and to give up His life instead of keeping

it, yet was He by those very means to attain His prayer, so that He might reign for ever and ever, and be able to say, "I am He that liveth, and was dead, and behold I am alive for evermore."

PSALM XXII.

The special consecration of this Psalm by our Lord's use of its opening words in the most awful moment of His Passion, has invested it for ever with a royal grandeur of Divine sorrow¹.

The opening words recall to mind the force which was after-

¹ St. Augustine speaks of this Psalm as being used on the day of our Lord's Passion.

The IV. Day.
Evening
Prayer.
Luke vi. 16.
vi. 12.
John xiii. 30.
Job ii. 10.

2 O my God, I cry in the day-time, but thou hearest not : and in the night-season also I take no rest.

3 And thou continuest holy : O thou worship of Israel.

4 Our fathers hoped in thee : they trusted in thee, and thou didst deliver them.

5 They called upon thee, and were holpen : they put their trust in thee, and were not confounded.

Isa. liii. 2, 3.
Job xxv. 6.

6 But as for me, I am a worm, and no man : a very scorn of men, and the outcast of the people.

Matt. xxvii. 39.

7 All they that see me, laugh me to scorn : they shoot out their lips, and shake their heads, saying,

Matt. xxvii. 43.

8 He trusted in God, that he would deliver him : let him deliver him, if he will have him.

9 But thou art he that took me out of my mother's womb : thou wast my hope when I hanged yet upon my mother's breasts.

10 I have been left unto thee ever since I was born : thou art my God even from my mother's womb.

Isa. lxxiii. 3, 5.

11 O go not from me, for trouble is hard at hand : and there is none to help me.

Isa. xxxiv. 7.

12 Many oxen are come about me : fat bulls of Basan close me in on every side.

Luke xxiii. 35.

13 They gape upon me with their mouths : as it were a ramping and a roaring lion.

Isa. liii. 4.

14 I am poured out like water, and all my bones are out of joint : my heart also in the midst of my body is even like melting wax.

John xix. 28.
Luke xxiii. 36.

15 My strength is dried up like a potsherd, and my tongue cleaveth to my gums : and thou shalt bring me into the dust of death.

Matt. vii. 6.

16 For many dogs are come about me : and the council of the wicked layeth siege against me.

Deus meus, clamabo per diem, et non exaudies : et nocte, et non ad insipientiam mihi.

Tu autem in sancto habitas : Laus Israël.

In te speraverunt patres nostri : speraverunt, et liberasti eos.

Ad te clamaverunt, et salvi facti sunt : in te speraverunt, et non sunt confusi.

Ego autem sum vermis, et non homo : opprobrium hominum, et abjectio plebis.

Omnes videntes me deriserunt me : locuti sunt labiis, et moverunt caput. qui videbant me aspernabantur me

Speravit in Domino : eripiat eum : salvum faciat eum, quoniam vult eum.

Quoniam tu es qui extraxisti me de ventre ; spes mea ab uberibus matris meæ : in te projectus sum ex utero. jactatus sum

De ventre matris meæ Deus meus es tu : ne discesseris a me.

Quoniam tribulatio proxima est : quoniam non est qui adjuvet.

Circumderunt me vituli multi : tauri pingues obsederunt me.

Aperuerunt super me os suum : sicut leo rapiens et rugiens.

Sicut aqua effusus sum : et dispersa sunt omnia ossa mea. effusa sunt et

Factum est cor meum tanquam cera liquescens : in medio ventris mei. liquefens

Aruit tanquam testa virtus mea, et lingua mea adhæsit faucibus meis : et in pulverem mortis deduxisti me. Exaruit velut testa deduxerunt

Quoniam circumderunt me canes multi : concilium malignantium ob-sedit me.

wards given to them by our Lord, when, even after His Resurrection, He declared His perfect Humanity and His capacity for perfect Union with Human Nature by saying, "I ascend unto My Father and your Father, and to My God and your God." [John xx. 17.] They reveal at once the One Man of Sorrows making Himself one with those whom He had come to redeem.

But the words that follow, and which give the key-note to the whole awful strain of sorrow, indicate the mystery of that dark-

ness which was to fall upon the soul of Him Whose Body was already suffering the fulness of pain upon the Cross. In that hour, it may be from noon till three o'clock, the vast burden of all sin was concentrated upon the Redeemer's Soul ; and with it the still more unbearable burden of that Divine displeasure which sin calls down from the All-Righteous God. In what way the Divine Presence was hid from the sight of Him whose Human Nature was inseparably joined to His Godhead, can be

The IV. Day. Evening Prayer. John xx. 25. 27. Matt. xxvii. 36. Luke xxiii. 34. John xlx. 23, 24.	17 They pierced my hands and my feet, I may tell all my bones : they stand staring and looking upon me.	Foderunt manus meas et pedes meos : dinumeraverunt omnia ossa mea.
	18 They part my garments among them : and cast lots upon my vesture.	Ipsi vero consideraverunt et inspexerunt me : diviserunt sibi vestimenta mea, et super vestem meam miserunt sortem.
	19 But be not thou far from me, O Lord : thou art my succour, haste thee to help me.	Tu autem Domine ne elongaveris auxilium tuum a me : ad defensionem meam aspice.
2 Tim. iv. 17. Isa. xxxiv. 7.	21 Save me from the lion's mouth : thou hast heard me also from among the horns of the unicorns.	Erue a framea Deus animam meam : et de manu canis unicam meam.
Luke xxiii. 34. 46. John xx. 17. 21. Heb. ii. 12.	22 I will declare thy Name unto my brethren : in the midst of the congregation will I praise thee.	Salva me ex ore leonis : et a cornibus unicornium, humilitatem meam.
	23 O praise the Lord, ye that fear him : magnify him, all ye of the seed of Jacob, and fear him, all ye seed of Israel.	Narrabo Nomen tuum fratribus meis : in medio Ecclesiæ laudabo te. Qui timetis Dominum, laudate eum : universum semen Jacob glorificate eum.
Luke xxiii. 46. James ii. 6. Isa. lx. 1. Lxii. 12.	24 For he hath not despised, nor abhorred, the low estate of the poor : he hath not hid his face from him, but when he called unto him he heard him.	Timeat eum omne semen Israël : quoniam non sprevit neque despexit deprecationem pauperis.
Isa. lx. 3. 20. John vi. 51.	25 My praise is of thee in the great congregation : my vows will I perform in the sight of them that fear him.	Nec avertit faciem suam a me : et cum clamarem ad eum exaudivit me.
John vi. 54 James ii. 5.	26 The poor shall eat, and be satisfied : they that seek after the Lord shall praise him ; your heart shall live for ever.	Apud te laus mea in Ecclesia magna : vota mea reddam in conspectu timentium eum.
Isa. liii. 11.	27 All the ends of the world shall remember themselves, and be turned unto the Lord : and all the kindreds of the nations shall worship before him.	Edent pauperes et saturabuntur, et laudabunt Dominum qui requirunt eum : vivent corda eorum in sæculum sæculi.
Rev. vii. 9. xi. 15.	28 For the kingdom is the Lord's : and he is the Governór among the people.	Remiscentur et convertentur ad Dominum : universi fines terræ. Et adorabunt in conspectu ejus : universæ familiæ Gentium.
Isa. lv. 2. John vi. 55.	29 All such as be fat upon earth : have eaten, and worshipped.	Quoniam Domini est regnum : et ipse dominabitur Gentium.

explained by no uninspired pen, and has not been revealed by the Holy Ghost. The words themselves reveal the fact, and all that can be said beyond is, that they form a comprehensive commentary on the words of the prophet, "Surely He hath borne our griefs and carried our sorrows" [Isa. liii. 4], and on those of the Apostle, "For He hath made Him to be sin for us Who knew no sin." [2 Cor. v. 21. Gal. iii. 13.]

The body of the Psalm has so exact a correspondence with the narrative of the Crucifixion as to furnish an irrefutable illustration of the truth, that "all Scripture is given by inspiration of God" [2 Tim. iii. 16]: for only the Omniscience of Him to Whom all time is one continual present could have foreseen the circumstances so exactly named. It should therefore be taken,

in the same manner as the fifty-third chapter of Isaiah, as a Divine exposition and commemoration of the Passion. Viewed in this light, it shows how utter was the depth of humiliation to which Christ descended that He might reach to the lowest of sinners. The patriarchs and many holy men had called on God, and He had delivered them. Abraham at the sacrifice of Isaac, Joseph in the pit, Job when stricken to the ground with misery, Daniel in the lion's den, the three holy Children in the Babylonian furnace—these had been heard from Heaven ; but Christ was to go through with His sacrifice, was to descend into the lowest pit, a place of darkness, and into the deep ; was to have His visage more marred than Job or any sons of men ; was to have His soul more among lions than was Daniel's body, and to go

The IV. Day.
Evening
Prayer.
John vi. 57.

30 All they that go down into the dust, shall kneel before him : and no man hath quickened his own soul.

1 Pet. i. 23, ii. 9.
Rev. vii. 4, 9.

31 My seed shall serve him : they shall be counted unto the Lord for a generation.

Isa. lxiii. 7, 8.
Luke xxiv. 47.

32 They shall come, and the heavens shall declare his righteousness : unto a people that shall be born whom the Lord hath made.

THE XXIII PSALM.

Dominus regit me.

Ezek. xxxiv. 31.
John x. 11—15.

THE Lord is my shepherd : therefore can I lack nothing.

Rev. vii. 16, 17.

2 He shall feed me in a green pasture : and lead me forth beside the waters of comfort.

3 He shall convert my soul : and bring me forth in the paths of righteousness for his Name's sake.

Isa. xi. 1.
Zech. xi. 7, 10.

4 Yea, though I walk through the valley of the shadow of death, I will fear no evil : for thou art with me, thy rod and thy staff comfort me.

Mark i. 13.
Luke xxii. 30.
Rev. xix. 9.

5 Thou shalt prepare a table before me against them that trouble me : thou hast anointed my head with oil, and my cup shall be full.

John viii. 35.
xiv. 2.
Rev. xxi. 2.

6 But thy lovingkindness and mercy shall follow me all the days of my life : and I will dwell in the house of the Lord for ever.

Manducaverunt et adoraverunt omnes pingues terræ : in conspectu ejus *divites* cadent omnes qui descendunt in terram. *procedunt univ. rsi*

Et anima mea illi vivet : et semen meum serviet ipsi.

Annuntiabitur Domino generatio ventura : et annuntiabunt celi justitiam ejus populo qui nascetur, quem fecit Dominus.

PSALMUS XXII.

DOMINUS regit me, et nihil mihi deerit : in loco pascuæ ibi me collocavit. *Prime. Mattins of the departed.*

Super aquam refectiois educavit me : animam meam convertit.

Deduxit me super semitas justitiæ : propter Nomen suum.

Nam et si ambulavero in medio *ambulem* umbræ mortis : non timebo mala, quoniam tu mecum es.

Virga tua et baculus tuus : ipsa me consolata sunt.

Parasti in conspectu meo mensam : adversus eos qui tribulant me.

Impinguasti in oleo caput meum : et calix meus inebrians quam præclarus *poculum tuum* est.

Et misericordia tua subsequetur me : omnibus diebus vitæ meæ.

Et ut inhabitem in domo Domini : in longitudinem dierum.

through a furnace of affliction far fiercer than that of Babylon. And instead of being able to say in the midst of all, "Our God Whom we serve is able to deliver us," He was to suffer a darkness more terrible than death, so that He could say, "I am a worm, and no man" . . . "why hast Thou forsaken Me?" . . . "I cry, but Thou hearest not."

Even this awful prophecy and exposition of the Passion, however, passes on to a declaration of the joy and victory which were to spring out of it : and the latter half of the Psalm foreshadows the resignation with which Christ was able to commend His spirit to the Father, the joy with which He could look forth on the travail of His soul and be satisfied : God heard the Poor when He called unto Him, and did not continue to hide His face from Him.

The 25th and 26th verses are a prophecy of the Holy Eucharist. Christ had said, "The bread which I will give is My Flesh, which I will give for the life of the world," and "He that eateth Me, even he shall live by Me;" and by His Death on the Cross He performed the vow which He had thus made, so that the members of His mystical Body might eat of the Life-giving Food, and be satisfied with that Flesh which is meat indeed.

PSALM XXIII.

This sweet Hymn is the voice of Christ speaking in His members according to that mystical relation shadowed forth by

His being both the Lamb and the Shepherd, and according to His words, "Without Me ye can do nothing." As the Lamb of God He Himself walked through the valley of the shadow of death; as the Good Shepherd He supports those who go thither by the sceptre of His Incarnation, and by the staff of His Cross, the staff of Beauty and the staff of Bands¹. [Zech. xi. 7—12.]

This Psalm seems to follow the 22nd in natural order, that being the agonized prayer of the Cross, this the peaceful praise of Paradise. And as there was a rest for the Shepherd, so is there a rest prepared for the sheep : when "they shall hunger no more, neither thirst any more ; neither shall the sun light on them, nor any heat. For the Lamb which is in the midst of the throne shall feed them, and shall lead them unto living fountains of waters ; and God shall wipe away all tears from their eyes." All which, both in the Psalm and in the Revelation, seems to point to a sacramental Life in Christ both here and hereafter ; here in the Holy Eucharist, hereafter in the restored Tree of Life whose leaves are for the healing of the nations, and whereof the redeemed may "eat and live for ever" in a re-opened Paradise.

The fifth verse of this Psalm may be a constant reminder to us that the Blessed Sacrament is the true remedy of the Christian against the Evil One and his temptations. Angels came to pre-

¹ This was a Burial Psalm in the time of St. Chrysostom.

THE XXIV PSALM.

Domini est terra.

The V. Day.
Morning
Prayer.

Ascension Day,
Evensong.
1 Cor. x. 26. 28.
Gen. i. 2. 9.

John iii. 13.

Heb. vii. 26.

Eph. i. 3.

Rev. xxii. 4.
Isa. ix. 1.

Acts i. 9.
vii. 56.
Rev. xi. 17.

Isa. lxiii. 1.

1 Pet. iii. 22.
Isa. ix. 11.

Rev. xix. 16.

THE earth is the Lord's, and all that therein is : the compass of the world, and they that dwell therein.

2 For he hath founded it upon the seas : and prepared it upon the floods.

3 Who shall ascend into the hill of the Lord : or who shall rise up in his holy place ?

4 Even he, that hath clean hands, and a pure heart : and that hath not lift up his mind unto vanity, nor sworn to deceive his neighbour.

5 He shall receive the blessing from the Lord : and righteousness from the God of his salvation.

6 This is the generation of them that seek him : even of them that seek thy face, O Jacob.

7 Lift up your heads, O ye gates, and be ye lift up, ye everlasting doors : and the King of glory shall come in.

8 Who is the King of glory : it is the Lord strong and mighty, even the Lord mighty in battle.

9 Lift up your heads, O ye gates, and be ye lift up, ye everlasting doors : and the King of glory shall come in.

10 Who is the King of glory : even the Lord of hosts, he is the King of glory.

THE XXV PSALM.

Ad te, Domine, levavi.

Isa. l. 7.

UNTO thee, O Lord, will I lift up my soul, my God, I have put my trust in thee : O let me not be confounded, neither let mine enemies triumph over me.

PSALMUS XXIII.

DOMINI est terra, et plenitudo ejus : orbis terrarum, et universi qui habitant in eo.

Quia ipse super maria fundavit eum : et super flumina præparavit eum.

Quis ascendet in montem Domini ? aut quis stabit in loco sancto ejus ?

Innocens manibus et mundo corde ; qui non accepit in vano animam suam : nec juravit in dolo proximo suo.

Hic accipiet benedictionem a Domino : et misericordiam a Deo salutari suo.

Hæc est generatio quærentium eum : quærentium faciem Dei Jacob.

Attollite portas, principes, vestras, et elevamini portæ æternales : et introibit rex gloriæ.

Quis est iste rex gloriæ ? Dominus fortis et potens, Dominus potens in prælio.

Attollite portas, principes, vestras, et elevamini portæ æternales : et introibit rex gloriæ.

Quis est iste rex gloriæ ? Dominus virtutum, ipse est rex gloriæ.

Prime.
Circumc., Trinity
Sund., Martyrs,
Mattins.
1st Noct.
Easter Eve.
St. Michael,
2nd Noct.
eam . . . illam

Tollite

Tollite

PSALMUS XXIV.

AD te Domine levavi animam meam, Deus meus, in te confido : non erubescam.

Neque irrideant me inimici mei :

Prime.
B. V. M., Mattins,
1st Noct.
Matt. of the de-
parted.

pare a table for Christ in the wilderness of temptation ; but He Himself prepares one for His people in the Church.

PSALM XXIV.¹

As the last Psalm sang of the transition of Christ from the death of the Cross to the rest of Paradise, so does this of His Ascension into Heaven.

By His Death the Lord has gained all those kingdoms of the earth, and the glory of them, which were offered to Him at the Temptation. As the Spirit of God brooded over the waters of chaos, and there sprung therefrom the solid earth of the natural creation, so has the Kingdom of Christ been founded upon the

¹ The first verse of this Psalm has received a new historical interest from the striking application given to it by its conspicuous position on the front of the Royal Exchange, at the centre of the world's commerce.

*water-floods which overwhelmed the Saviour in His sufferings, and the sacramental stream which flowed from His side. So also is the Church supported safely on the waves of this troublesome world, as the Ark in the deluge, or the Apostles' boat in the storm, because of His Presence Who has prepared it upon the floods.

The middle verses may be compared with the 15th Psalm, and are a prelude to the four triumphant verses which form the main idea of this Hymn of victory. The King of Glory first entered on His Triumph when He smote those gates of brass and brake those bars of iron asunder, which He had declared should not prevail against His Church, and therefore could not against Him. A second time the cry went forth, Who is the King of Glory ? when He who had come with dyed garments from Bozrah, ascended up to Heaven to make a continual offering of His Body before the Throne. A third time He will ride forth at the head

The V. Day. Morning Prayer.	2 For all they that hope in thee shall not be ashamed : but such as transgress without a cause shall be put to confusion.	etenim universi qui sustinent te non confundentur.	universi qui expectant Dominum non confundentur.
	3 Shew me thy ways, O Lord : and teach me thy paths.	Confundantur omnes iniqua agentes : supervacue.	conf. iniqui facientes tana
John xiv. 6.	4 Lead me forth in thy truth, and learn me : for thou art the God of my salvation ; in thee hath been my hope all the day long.	Vias tuas Domine demonstra mihi : et semitas tuas edoce me.	vias tuas Domine notas fac mihi
Joel ii. 13.	5 Call to remembrance, O Lord, thy tender mercies : and thy lovingkindnesses, which have been ever of old.	Dirige me in veritate tua, et doce me : quia tu es Deus salvator meus, et te sustinui tota die.	
Heb. ii. 17. Luke xxiii. 42.	6 O remember not the sins and offences of my youth : but according to thy mercy think thou upon me, O Lord, for thy goodness.	Reminiscere miserationum tuarum Domine : et misericordiarum tuarum, quæ a sæculo sunt.	
	7 Gracious, and righteous is the Lord : therefore will he teach sinners in the way.	Delicta juventutis meæ : et ignorantias meas ne memineris.	
John vi. 44, 45.	8 Them that are meek shall he guide in judgement : and such as are gentle, them shall he learn his way.	Secundum misericordiam tuam memento mei tu : propter bonitatem tuam, Domine.	magnam misericordiam tuam memor esto mei Deus
Matt. xi. 25, 29, James i. 21.	9 All the paths of the Lord are mercy, and truth : unto such as keep his covenant, and his testimonies.	Dulcis et rectus Dominus : propter hoc legem dabit delinquentibus in via.	statuit
	10 For thy Name's sake, O Lord : be merciful unto my sin, for it is great.	Diriget mansuetos in judicio : docebit mites vias suas.	Dirigit mites . . . docebit mansuetos
John xvii. 11.	11 What man is he, that feareth the Lord : him shall he teach in the way that he shall choose.	Universæ viæ Domini misericordia et veritas : requirentibus testamentum ejus et testimonia ejus.	
	12 His soul shall dwell at ease : and his seed shall inherit the land.	Propter nomen tuum Domine propitiaberis peccato meo : multum est enim.	copiosum
Isa. liii. 10.	13 The secret of the Lord is among them that fear him : and he will shew them his covenant.	Quis est homo qui timet Dominum ? legem statuit ei in via quam elegit.	
John vii. 17. xiv. 21.	14 Mine eyes are ever looking unto the Lord : for he shall pluck my feet out of the net.	Anima ejus in bonis demorabitur : et semen ejus hæreditabit terram.	hæreditate possidebit
	15 Turn thee unto me, and have mercy upon me : for I am desolate, and in misery.	Firmamentum est Dominus timentibus eum : et testamentum ipsius ut manifestetur illis.	
Matt xxvi. 38		Oculi mei semper ad Dominum : quoniam ipse evellet de laqueo pedes meos.	
		Respice in me, et miserere mei : quia unicus et pauper sum ego.	

of the armies of Heaven, clothed with a vesture dipped in blood, to tread "the winepress of the fierceness and wrath of Almighty God;" and once more will the cry go up, "Lift up your heads, O ye gates, and be ye lift up, ye everlasting doors;" "Worthy is the Lamb that was slain," "The marriage of the Lamb is come."

PSALM XXV.

In the penitential tone of this Psalm we hear again the voice of Christ speaking for His mystical Body, uniting Himself with all its members, so that He becomes the representative Israel pleading with God for pardon in their name. He is our merciful High Priest, bearing "the names of the children of Israel in the

breastplate of judgment upon His heart, when He goeth in unto the holy place" [Exod. xxviii. 9] "to appear in the presence of God for us." Accordingly we find, as in some other Psalms, several changes in the pronouns, sometimes a singular one being used, and at others a plural: "I have put my trust in Thee," "All they that hope in Thee." As "in all our afflictions He was afflicted" while on earth, so even now His perpetual Intercession embraces within its compass that experience of the burden of all sin which was acquired when He bore ours upon the Cross.

In the words of this Psalm, therefore, Christ is teaching us how to approach the Throne of mercy: "Take with you words, and turn to the Lord: say unto Him, Take away all iniquity, and

The V. Day.
Morning
Prayer.

16 The sorrows of my heart are enlarged : O bring thou me out of my troubles.

17 Look upon my adversity, and misery : and forgive me all my sin.

18 Consider mine enemies, how many they are : and they bear a tyrannous hate against me.

1 Pet. iv. 19

19 O keep my soul, and deliver me : let me not be confounded, for I have put my trust in thee.

20 Let perfectness, and righteous dealing wait upon me : for my hope hath been in thee.

John xvii. 9.
Rev. xxi. 4.

21 Deliver Israel, O God : out of all his troubles.

THE XXVI PSALM.

Judica me, Domine.

John xii. 28.
xiv. 30.

BE thou my Judge, O Lord, for I have walked innocently : my trust hath been also in the Lord, therefore shall I not fall.

Mal. iii. 3.

2 Examine me, O Lord, and prove me : try out my reins, and my heart.

3 For thy lovingkindness is ever before mine eyes : and I will walk in thy truth.

Heb. vii. 26.

4 I have not dwelt with vain persons : neither will I have fellowship with the deceitful.

Rev. ii. 2. 9.

5 I have hated the congregation of the wicked : and will not sit among the ungodly.

Exod. xxx. 18.

6 I will wash my hands in innocency, O Lord : and so will I go to thine altar ;

1 Cor. xi. 26.

7 That I may shew the voice of thanksgiving : and tell of all thy wondrous works.

Luke ii. 49.
Acts ii. 46.

8 Lord, I have loved the habitation of thy house : and the place where thine honour dwelleth.

Tribulationes cordis mei multipli- *dilatate* sunt
catae sunt : de necessitatibus meis erue *eripe* me
me.

Vide humilitatem meam, et laborem meum : et dimitte universa delicta *omnia peccata* mea.

Respice inimicos meos, quoniam multiplicati sunt : et odio iniquo ode- runt me.

Custodi animam meam, et erue me : *eripe* non erubescam, quoniam speravi in te. *non confundar quoniam invocavi te*

Innocentes et recti adhæserunt mihi : *quoniam . . . te Domine* quia sustinui te.

Libera, Deus, Israël : ex omnibus *Redime me . . . angustis meis* tribulationibus suis.

PSALMUS XXV.

JUDICA me, Domine, quoniam ego *Prime. Præparat. Missæ.* in innocentia mea ingressus sum : et in Domino sperans non infirmabor.

Proba me, Domine, et tenta me : ure renes meos et cor meum.

Quoniam misericordia tua ante oculos meos est : et complacui in veritate tua.

Non sedi cum concilio vanitatis : et cum iniqua gerentibus non introibo.

Odivi ecclesiam malignantium : et *congregationem malignorum* cum impiis non sedebo.

Lavabo inter innocentes manus meas : et circumdabo altare tuum Do- *circuido* mine.

Ut audiam vocem latdis tuæ : et enarrem universa mirabilia tua.

Domine, dilexi decorem domus tuæ : *locum tabernaculi (sic)* et locum habitationis gloriæ tuæ.

receive us graciously : so will we render the calves of our lips." [Hosea xiv. 2.] And hence it has been called a pattern of all prayer. Offered up by the Church of God, it is a continual acknowledgment of the sins of which human nature has ever been guilty before Him, from the time of its youth in our first parents to that of its old age in these latter days. Offered up by each Christian soul, it is a lowly confession before the righteous Judge of our general unworthiness and our particular sin ; of our sorrow for sin, and our desire to be strengthened against evil and the Evil One. It pleads the loving-kindness of God as evidenced in the days of old, and asks for a repetition of mercies from the inexhaustible fountain of His love : and, self-abased by remembrance of former falls, it beseeches Him to consider how great is

the power arrayed against us, and how utterly unable the sinner is to walk upright in the way of righteousness without His gracious leading, and support, and protection.

Thus, when we know not what to pray for as we ought, God Himself teaches us, and "the Spirit itself maketh intercession for us with groanings which cannot be uttered." [Rom. viii. 26.]

PSALM XXVI.

Sinners must appeal to the *mercy* of their Judge ; but He in Whom was no guile could appeal to His strict *justice*. Only of Christ therefore can this Psalm be spoken in its literal meaning ; while others who say, "Be Thou my Judge, O Lord," must add, "If Thou, Lord, shouldst be extreme to mark what is done

The V. Day.
Morning
Prayer.

9 O shut not up my soul with the sinners : nor my life with the blood-thirsty ;

10 In whose hands is wickedness : and their right hand is full of gifts.

11 But as for me, I will walk innocently : O deliver me, and be merciful unto me.

Heb. ii. 12.

12 My foot standeth right : I will praise the Lord in the congregations.

THE XXVII PSALM.

Dominus illuminatio.

Evening
Prayer.
1 John i. 5.
Isa. lx. 1. 20.
Rev. xxi. 23.

THE Lord is my light, and my salvation ; whom then shall I fear : the Lord is the strength of my life ; of whom then shall I be afraid ?

John xviii. 6.

2 When the wicked, even mine enemies, and my foes came upon me to eat up my flesh : they stumbled and fell.

Matt. xxvi. 53.
Rom. viii. 38.

3 Though an host of men were laid against me, yet shall not my heart be afraid : and though there rose up war against me, yet will I put my trust in him.

Luke ii. 49.
Isa. vi. 1.
xxxiii. 17.
Rev. iv. 3.
xxi. 22.

4 One thing have I desired of the Lord, which I will require : even that I may dwell in the house of the Lord all the days of my life, to behold the fair beauty of the Lord, and to visit his temple.

Exod. xxxiii. 21.
1 Cor. x. 4.
Matt. xvi. 18.
xxi. 44.

5 For in the time of trouble he shall hide me in his tabernacle : yea, in the secret place of his dwelling shall he hide me, and set me up upon a rock of stone.

Ne perdas cum impiis Deus animam *impis animam*
meam : et cum viris sanguinum vitam
meam.

In quorum manibus iniquitates sunt : dextera eorum repleta est muneribus.

Ego autem in innocentia mea ingressus sum : redime me, et miserere mei.

Pes meus stetit in directo : in ec- *Pes enim . . . in*
clesiis benedicam te, Domine. *via recta . . .*
Domini

PSALMUS XXVI.

DOMINUS illuminatio mea : et *Mond. Mattins.*
salus mea ; quem timebo ? *Good Friday,*
1st Noct.

Dominus protector vitæ meæ : a quo *Easter Eve,*
trepidabo ? *2nd Noct.*
Matt. of the de-
parted.
Domini defensor
vitæ

Dum appropiant super me nocentes :
ut edant carnes meas ;

Qui tribulant me inimici mei : ipsi
infirmati sunt et ceciderunt.

Si consistant adversum me castra :
non timebit cor meum.

Si exsurgat adversum me prælium : *si insurgat in me*
in hoc ego sperabo.

Unam petii a Domino, hanc requiram :
ut inhabitem in domo Domini
omnibus diebus vitæ meæ.

Ut videam voluntatem Domini : et *protegar a templo*
visitem templum ejus. *sancto ejus*

Quoniam abscondit me in tabernaculo suo
in die malorum : protexit me in abscondito tabernaculi sui.

amiss, O Lord, who shall stand?" But although we can only imperfectly copy the Pattern of perfect righteousness, and walk with faltering steps in the pathway which He has trodden, yet Christ has left us an example in the words of this Psalm of the manner in which alone an acceptable approach can be made to the Altar of God. He entered into Heaven in the strength of His innocence, we must come before God's Altar in the strength of our penitence.

This Psalm has accordingly been used from time immemorial as part of the private prayers of the Celebrant when he is about to offer up the Eucharistic Sacrifice to God. In the same spirit and with the same intention it may be used by all Christians, since all have their part in the offering made by their ministerial leader. And at whatever time the Psalm is sung, it must remind all who use it, clergy or laity, of that High Priest who was "holy, harmless, undefiled, separate from sinners," as an Example to all who engage in the service of God.

PSALM XXVII.

Christ spake words in this Psalm for Himself, His Church, and for each Christian soul ; expressing that faith in the Presence of God which He had in its perfection, and which is given to His servants to possess according to the measure of the gift of Him.

Most of the Psalm applies literally to Christ in the time of His Passion, the "false witnesses" of the fourteenth verse being an evident prophecy of those who came and perverted our Lord's words respecting the resurrection of the temple of His body. In the very first words there appears an implied reference to the physical and spiritual darkness by which He was surrounded when on the cross ; the stumbling and falling of those who had come against Him in the Garden of the Agony is in the same way referred to in the second verse ; the lifting up of His head in the sixth verse carries the thoughts to His lifting up on the Cross by which He gained the throne of an everlasting kingdom ; and the

The V. Day.
Evening
Prayer.
John iii. 14.
xii. 32.
1 Cor. xi. 26.

6 And now shall he lift up mine head : above mine enemies round about me.

7 Therefore will I offer in his dwelling an oblation with great gladness : I will sing, and speak praises unto the Lord..

Heb. xii. 21.

8 Hearken unto my voice, O Lord, when I cry unto thee : have mercy upon me, and hear me.

Exod. xxxiii. 19,
20.
Rev. xxii. 4.

9 My heart hath talked of thee, Seek ye my face : Thy face, Lord, will I seek.

10 O hide not thou thy face from me : nor cast thy servant away in displeasure.

John xii. 28.

11 Thou hast been my succour : leave me not, neither forsake me, O God of my salvation.

12 When my father and my mother forsake me : the Lord taketh me up.

John xiv. 16.

13 Teach me thy way, O Lord : and lead me in the right way, because of mine enemies.

Mark xiv. 57.
Ps. xxxv. 11.

14 Deliver me not over into the will of mine adversaries : for there are false witnesses risen up against me, and such as speak wrong.

15 I should utterly have fainted : but that I believe verily to see the goodness of the Lord in the land of the living.

Isa. xl. 31.
Acts i. 4.

16 O tarry thou the Lord's leisure : be strong, and he shall comfort thine heart, and put thou thy trust in the Lord.

THE XXVIII PSALM.

Ad te, Domine.

UNTO thee will I cry, O Lord my strength : think no scorn of me, lest, if thou make as though thou hearest not, I become like them that go down into the pit.

In petra exaltavit me : et nunc exaltavit caput meum super inimicos meos.

Circuivi, et immolavi in tabernaculo ejus hostiam vociferationis : cantabo et psalmum dicam Domino. Circuibo et immolabo hostiam jubilatioms

Exaudi, Domine, vocem meam qua clamavi ad te : miserere mei, et exaudi me.

Tibi dixit cor meum, exquisivit te facies mea : faciem tuam, Domine, requiram. exquisivi vultum tuum : vultum tuum Domine

Ne avertas faciem tuam a me : ne declines in ira a servo tuo.

Adjutor meus esto ; ne derelinquas me : neque despicias me, Deus salutaris meus.

Quoniam pater meus et mater mea dereliquerunt me : Dominus autem assumpsit me.

Legem pone mihi, Domine, in via tua : et dirige me in semita recta propter inimicos meos. mihî constitue

Ne tradideris me in animas tribulantium me, quoniam insurrexerunt in me testes iniqui : et mentita est iniquitas sibi. persequuntur

Credo videre bona Domini : in terra viventium.

Exspecta Dominum, viriliter age, et confortetur cor tuum : et sustine Dominum.

PSALMUS XXVII.

AD te, Domine, clamabo ; Deus meus, ne sileas a me : nequando taceas a me et assimilabor descendentibus in lacum. Mond. Mattins. ne sileas a me et ero similis

oblation of the seventh to that sacrifice of praise and thanksgiving whose efficacy is derived from the "full, perfect, and sufficient sacrifice, oblation, and satisfaction for the sins of the whole world" there made by Him. We may also observe that "My voice" in the eighth verse follows immediately after the prophecy of the Sacrifice offered on the Cross and re-presented in the Eucharist, and that it can scarcely be otherwise interpreted than of Christ's perpetual Intercession, and of the "blood that speaketh better things than that of Abel." And in the sixteenth verse we are reminded of His saying, "Mine hour is not yet come."

Not less may the Psalm be taken as an aspiration of Christ

speaking in His members. In the hour of trial faith looks upward, remembering that "God is light." Even when the Virgin, the daughter of Sion, is sitting in the dust, she hears the voice from on high, "Arise, shine, for thy Light is come," or "The Lord shall be unto thee an everlasting Light, and thy God thy glory:" and though troubles may be on every side, yet is there the glory of the regenerated City of God in the future, when it shall have no need to be illuminated by any but spiritual joy, for "the Lamb is the Light of it."

For such a joy the individual Christian also may hope, desiring that he may dwell for ever in this house of the Lord, and behold

The V. Day.
Evening
Prayer.
Luke xxiii. 33.

2 Hear the voice of my humble petitions, when I cry unto thee : when I hold up my hands towards the mercy-seat of thy holy temple.

3 O pluck me not away, neither destroy me with the ungodly, and wicked doers : which speak friendly to their neighbours, but imagine mischief in their hearts.

4 Reward them according to their deeds : and according to the wickedness of their own inventions.

5 Recompense them after the work of their hands : pay them that they have deserved.

Isa. v. 13.
Rom. i. 21.
2 Pet. iii. 4.

6 For they regard not in their mind the works of the Lord, nor the operation of his hands : therefore shall he break them down, and not build them up.

7 Praised be the Lord : for he hath heard the voice of my humble petitions.

Gen. xv. 1.
John xi. 41.

8 The Lord is my strength, and my shield, my heart hath trusted in him, and I am helped : therefore my heart danceth for joy, and in my song will I praise him.

9 The Lord is my strength : and he is the wholesome defence of his Anointed.

10 O save thy people, and give thy blessing unto thine inheritance : feed them, and set them up for ever.

THE XXIX PSALM.

Afferte Domino.

John x. 35.

BRING unto the Lord, O ye mighty, bring young rams unto the Lord : ascribe unto the Lord worship and strength.

Exaudi, Domine, vocem deprecationis meae dum oro ad te : dum extollo manus meas ad templum sanctum tuum.

Ne simul tradas me cum peccatoribus : et cum operantibus iniquitatem ne perdas me.

Qui loquuntur pacem cum proximo suo : mala autem in cordibus eorum.

Da illis secundum opera eorum : et secundum nequitiam adinventionum ipsorum.

Secundum opera manuum eorum tribue illis : redde retributionem eorum ipsis.

Quoniam non intellexerunt opera Domini : et in opera manuum ejus destrues illos, et non ædificabis eos.

Benedictus Dominus : quoniam exaudivit vocem deprecationis meae.

Dominus adjutor meus, et protector meus : et in ipso speravit cor meum, et adjutus sum.

Et reffloruit caro mea : et ex voluntate mea confitebor ei.

Dominus fortitudo plebis suae : et protector salvationum Christi sui est.

Salvum fac populum tuum Domine, et benedic hereditati tuae : et rege eos, et extolle illos usque in æternum.

PSALMUS XXVIII.

AFFERTE Domino, filii Dei : afferte Domino filios arietum.

the fairness of the "King in His beauty." Moses "talked of God, Seek ye My face," but God told him that he could not see His face and live, and he beheld only part of the Divine glory while "standing upon the rock," and hid in the "clift of the rock." The Rock of Ages has been cleft that the children of God may find a safe hiding-place for ever, and the Divine glory is now revealed in the Incarnate Person of the Lord Jesus. So the time will come when a yet higher vision of it will be vouchsafed, when there shall be no more fainting, and when they who wait upon the Lord shall go from strength to strength till His words are fulfilled, "They shall see His face; and His Name shall be in their foreheads. And there shall be no night there: and they need no candle, neither light of the sun; for the Lord God giveth them light: and they shall reign for ever and ever."

PSALM XXVIII.

Christ's Human Nature here cries to the Divine Nature: His

Mystical Body prays to Him and in Him as He stands by the throne of the Father. The following paraphrase from Gerholdus strikes the key-note of the Psalm with a clear tone, and shows the manner in which saintly writers have heard the voice of Christ speaking by the mouth of David:—

"I, the assumed Human Nature, will cry unto Thee, O Lord : Thou art My Deity, in which I, the Son of David, am the Son of God, equally as the Father and the Holy Ghost are God : Thou art My Deity, and since Thou art the Word of the Father, keep not silence from Me, from Me, the Human Nature which Thou, O Word, didst personally unite to Thyself. By the voice of Thy blood, crying from the ground, do Thou, O Word, so speak as to be heard, even in Hell, when my soul shall descend thither : make manifest that I am not like them that go down into the pit, from the weight of original, or the guilt of actual, sin. For I, untainted by any sin, shall so be 'free among the dead,' that I also shall be able to deliver others thence, and to say even to

Mond. Mattins.
Epiphany.
1st Noct.

The V. Day.

*Evening**Prayer.*

Rev. iv. 11.

xix. 5, 6.

Matt. viii. 26.

John xxi. 6.

Rev. x. 3.

2 Give the Lord the honour due unto his Name : worship the Lord with holy worship.

3 It is the Lord that commandeth the waters : it is the glorious God that maketh the thunder.

Rev. xx. 13.

4 It is the Lord that ruleth the sea ; the voice of the Lord is mighty in operation : the voice of the Lord is a glorious voice.

Isa. xl. 3.

5 The voice of the Lord breaketh the cedar-trees : yea, the Lord breaketh the cedars of Libanus.

6 He maketh them also to skip like a calf : Libanus also, and Sirion like a young unicorn.

Acts ii. 3.

Matt. iii. 3.

Isa. xxxv. 1.

7 The voice of the Lord divideth the flames of fire, the voice of the Lord shaketh the wilderness : yea, the Lord shaketh the wilderness of Cades.

John xvi. 14.

8 The voice of the Lord maketh the hinds to bring forth young, and discovereth the thick bushes : in his temple doth every man speak of his honour :

Gen. i. 2.

John iii. 5.

Acts ii. 47.

9 The Lord sitteth above the water-flood : and the Lord remaineth a King for ever.

1 John ii. 14.

John xiv. 27.

Gal. v. 22.

10 The Lord shall give strength unto his people : the Lord shall give his people the blessing of peace.

Afferte Domino gloriam et honorem, afferte Domino gloriam Nomini ejus : adorete Dominum in atrio sancto ejus. *aula sanota*

Vox Domini super aquas, Deus majestatis intonuit : Dominus super aquas multas.

Vox Domini in virtute : vox Domini in magnificentia.

Vox Domini confringentis cedros : et confringet Dominus cedros Libani :

Et comminet eas tanquam vitulum Libani : et dilectus quemadmodum filius *sicut* unicornium.

Vox Domini intercidentis flammam ignis ; vox Domini concutientis desertum : et commovebit Dominus desertum Cades. *solitudinem*

Vox Domini præparentis cervos, et revelabit condensa : et in templo ejus omnes dicent gloriam.

Dominus diluvium inhabitare facit : *inhabitat* et sedebit Dominus Rex in æternum.

Dominus virtutem populo suo dabit : Dominus benedicet populo suo in pace. *et benedicet*

death itself, 'O death, where is thy sting? O grave, where is thy victory?'"

The last four verses of the Psalm exhibit again the transition from humiliation and death to triumph and life, in the person of God's Anointed; and the union of Christ with His people in the closing words of faithful and joyful prayer. The last of all is used daily by the Church in the suffrages of Mattins and Evensong,—"O Lord, save Thy people. R. And bless Thine inheritance;" and also in the Te Deum, "Govern them, and lift them up for ever."

PSALM XXIX.

This is a song of praise and thanksgiving to God for the work wrought by the Holy Ghost in the kingdom of the New Creation. The perpetual presence of the Lord in His Church is signified by the mention of His Voice, of which it is said in the prophecy of the New Testament that "out of the throne proceeded lightnings and thunderings and voices." The same prophecy also speaks of "seven lamps of fire burning before the throne, which are the Seven Spirits of God" [Rev. iv. 5], and hence we may understand that the sevenfold operations of the Holy Ghost are mystically set forth by the seven times repeated "voice of the Lord."

As the Spirit of God moved upon the face of the waters of Creation, giving life to an inanimate world, so does He command the waters and rule the sea in the Sacrament of Baptism, the Laver or "Sea of glass" [Rev. iv. 6] "mingled with fire" [ibid. xv. 2], in which our fallen nature is regenerated to a life capable

of righteousness and a title to the inheritance of the saints in light. When God the Father glorified the Son of Man, some said that "it thundered," and only ears opened by faith heard the Voice of God as it declared, "I have both glorified it, and will glorify it again." [John xii. 28.] Only the faithful, again, knew the significance of that mysterious sign which appeared when the house was shaken where the Apostles were assembled on the morn of Pentecost, and the Holy Ghost divided the flaming tongues of fire upon the heads of those present. But, whether or not by visible and audible signs, the operation of the Holy Ghost is ever being carried on in the Church of God, by an endowment to it of power from on high; power given in Baptism, in Confirmation, in the Holy Eucharist; power to break up the strongest obstacles that oppose themselves; power to elevate the Church and the soul to the highest spiritual exaltation and "joy in the Holy Ghost;" power to shatter the oaks of the forest [verse 8], putting down the proud in the imagination of their hearts, and raising up a Saviour to reveal the mysteries hid in the "thick bushes" of prophecy.

In the Temple of the Holy Ghost, therefore,—in the mystical Body of Christ,—all things proclaim His glory Who still moveth upon the face of the waters to vivify, strengthen, and give final peace to His people. "The temple of God was opened in Heaven, and there was seen in His temple the ark of His Testament: and there were lightnings, and voices, and thunderings, and an earthquake, and great hail." "And the temple was filled with smoke from the glory of God, and from His power." [Rev. xi. 19; xv. 8.]

THE XXX PSALM.

*Exaltabo te, Domine.*The VI. Day.
Morning
Prayer.

I WILL magnify thee, O Lord, for thou hast set me up : and not made my foes to triumph over me.

2 O Lord my God, I cried unto thee : and thou hast healed me.

3 Thou, Lord, hast brought my soul out of hell : thou hast kept my life from them that go down to the pit.

4 Sing praises unto the Lord, O ye saints of his : and give thanks unto him for a remembrance of his holiness.

5 For his wrath endureth but the twinkling of an eye, and in his pleasure is life : heaviness may endure for a night, but joy cometh in the morning.

6 And in my prosperity I said, I shall never be removed : thou, Lord, of thy goodness hast made my hill so strong.

7 Thou didst turn thy face from me : and I was troubled.

8 Then cried I unto thee, O Lord : and gat me to my Lord right humbly.

9 What profit is there in my blood : when I go down to the pit ?

10 Shall the dust give thanks unto thee : or shall it declare thy truth ?

11 Hear, O Lord, and have mercy upon me : Lord, be thou my helper.

12 Thou hast turned my heaviness into joy : thou hast put off my sackcloth, and girded me with gladness.

13 Therefore shall every good man sing of thy praise without ceasing : O my God, I will give thanks unto thee for ever.

Heb. v. 7
xii. 24.
John xvii. 1.Jonah ii. 6.
Ps. xvi. 10.
Isa. xxxviii. 17.

Luke xxii. 19.

Isa. liv. 7, 8.
2 Cor. iv. 17.
v. 4.Matt. xxvii. 46,
47.

Heb. xii. 24.*

Isa. xxxviii. 18,
19.John xvi. 20-22.
Mark xvi. 12.
1 Cor. xv. 44.Cf. Bible Vers.
1 Cor. xi. 26.

PSALMUS XXIX.

EXALTABO te, Domine, quoniam suscepisti me : nec delectasti inimicos meos super me.

Domine Deus meus, clamavi ad te : et sanasti me.

Domine eduxisti ab inferno animam meam : salvasti me a descendentibus in lacum.

Psallite Domino omnes sancti ejus : et confitemini memoriae sanctitatis ejus.

Quoniam ira in indignatione ejus : et vita in voluntate ejus.

Ad vesperum demorabitur fletus : et ad matutinum lætitia.

Ego autem dixi in abundantia mea : Non movebor in æternum.

Domine, in voluntate tua : præstitisti decori meo virtutem.

Avertisti faciem tuam a me : et factus sum conturbatus.

Ad te, Domine, clamabo : et ad Deum meum deprecabor.

Quæ utilitas in sanguine meo : dum descendo in corruptionem ?

Nunquid confitebitur tibi pulvis : aut annuntiabit veritatem tuam ?

Audivit Dominus et misertus est mei : Dominus factus est adjutor meus.

Convertisti planctum meum in gaudium mihi : concidisti saccum meum, et circumdedisti me lætitia.

Ut cantet tibi gloria mea, et non compungar : Domine Deus meus, in æternum confitebor tibi.

Mond. Mattins.
Easter Eve.
2nd Noct.*abstraxisti ab inferis**bona vol.**præcinxisti*

PSALM XXX.

This Psalm is entitled "for the opening of the house of David," meaning probably for the dedication of the temple built by his son Solomon¹. Our Lord associated the Temple with a typical signification when He said of His own Body, "Destroy this temple, and in three days I will raise it up." [John ii. 19.] Not without reason, therefore, have wise interpreters associated this dedication Psalm with the dedication of Christ's Body in its Resurrection and Ascension, whereby was founded that mystical Body

¹ When the first-fruits were brought to be offered, those who brought them were accustomed to sing Psalm cxxii. as they came on their way to the temple, and Psalm cxi. on their closer approach to it. When they arrived within the court of the temple, the Levites sang Psalm xxx., perhaps from some association of ideas between the dedication of the temple and of the first-fruits.

which will also in His time be raised from its militant and suffering condition to be dedicated as the holy city and the new Jerusalem, "prepared as a bride adorned for her husband." [Rev. xxi. 2.]

The voice of Christ is heard, therefore, in this Psalm, rejoicing in His deliverance from death, the grave, and hell. The wrath of God came upon Him as the representative of all sinners, and for a time, the Father turned His face even from His beloved Son, so that the soul of the holy and innocent One was troubled. Giving up His life, that holy One suffered His body to be carried to the grave, while His soul descended into hell. But the dust of death could not magnify the glory of God, nor offer an Eucharistic sacrifice, nor give profit from the blood of the Atonement, nor proclaim Divine Truth. Therefore the Lord in His good purposes, for His own glory, and for man's salvation, brought the soul of Christ out of hell, kept His body from the usual lot of

THE XXXI PSALM.

In te, Domine, speravi.

The VI. Day.
Morning
Prayer.
Te Deum.

IN thee, O Lord, have I put my trust : let me never be put to confusion, deliver me in thy righteousness.

2 Bow down thine ear to me : make haste to deliver me.

3 And be thou my strong rock, and house of defence : that thou mayest save me.

4 For thou art my strong rock, and my castle : be thou also my guide, and lead me for thy Name's sake.

5 Draw me out of the net that they have laid privily for me : for thou art my strength.

Luke xxiii. 26.

6 Into thy hands I commend my spirit : for thou hast redeemed me, O Lord, thou God of truth.

Matt. xxiii. 1-33.

7 I have hated them that hold of superstitious vanities : and my trust hath been in the Lord.

8 I will be glad, and rejoice in thy mercy : for thou hast considered my trouble, and hast known my soul in adversities.

9 Thou hast not shut me up into the hand of the enemy : but hast set my feet in a large room.

Matt. xxvi. 38.

10 Have mercy upon me, O Lord, for I am in trouble : and mine eye is consumed for very heaviness ; yea, my soul and my body.

11 For my life is waxen old with heaviness : and my years with mourning.

Luke xxii. 44.

12 My strength faileth me, because of mine iniquity : and my bones are consumed.

PSALMUS XXX.

IN te, Domine, speravi ; non confundar in æternum : in justitia tua libera me.

Inclina ad me aurem tuam : accelera ut eruas me.

Esto mihi in Deum protectorem et in domum refugii : ut salvum me facias.

Quoniam fortitudo mea et refugium meum es tu : et propter nomen tuum deduces me, et enutries me.

Educes me de laqueo quem absconderunt mihi : quoniam tu es protector meus.

In manus tuas commendo spiritum meum : redemisti me, Domine Deus veritatis.

Odisti observantes vanitates : supervacue.

Ego autem in Domino speravi : exultabo et lætabor in misericordia tua.

Quoniam respexisti humilitatem meam : salvasti de necessitatibus animam meam.

Nec conclusisti me in manibus inimici : statuisti in loco spatioso pedes meos.

Miserere mei, Domine, quoniam tribulor : conturbatus est in ira oculus meus, anima mea et venter meus.

Quoniam defecit in dolore vita mea : et anni mei in gemitibus.

Infirmata est in paupertate virtus mea : et ossa mea conturbata sunt.

Mond. Mattins.
Compline, v. 1-6

libera me et eripe me

ut eripias me

locum ref.

Armamentum meum et ref.

dux mihi eris

occulta erunt

sperabo

meam salvam fecisti

those who descend into the grave, put off from Him the sackcloth of suffering humanity and a natural body, and girded Him with the joy of a humanity that is glorified and a body that has become spiritual. Because of this mercy of God towards man for the sake of his Redeemer, the Church, which is Christ's glory,—even the children which God has given to Him,—will praise Him continually, offering up to Him for ever the acceptable memorial of His love, according to His commandment, "This do, for a remembrance of Me."

The application of this Psalm to Christ the Head shows clearly without further illustration how it may be applied to His members, collectively and individually. When the time of her tribulation is past, the Church can follow the words of her Lord, and as He could say, "Thou hast set Me up" as the High Priest interceding, the King of kings ruling, and the Lamb of God receiving Divine worship, so may His Church praise God for revealing His glory by and in her, lifting her up from the dust and sackcloth of suffering, and girding her with the joy of an universal triumph. And there are times when the Christian soul may take such words for its own also, and thank God with a better informed faith

than Hezekiah did, when even he said, "The living, the living, he shall praise Thee, as I do this day."

PSALM XXXI.

This is another of the Psalms which our Lord has marked with the sign of the Cross, His last words at Calvary being taken from the sixth verse, "Father, into Thy hands I commend My spirit." It is an old tradition that He repeated all the Psalms from the twenty-second as far as this verse of the thirty-first, during the three hours of His extreme sufferings ; thus making these words the Compline hymn of His earthly life.

The Psalm is especially one of those in which Christ speaks as personating His people, or rather as concentrating within Himself all their experiences. Having taken our nature He speaks in our words, that we may the better learn to speak with His. Accordingly we hear Him speaking of God's mercy towards Him, although that mercy was needless for One whose immaculate nature could face the unmitigated justice of the All-Righteous ; and of His strength failing because of His iniquity, though all the sin which He bore was that of others. So He

The VI. Day.

*Morning**Prayer.*

Gal. v. 11.

1 Cor. i. 23.

Mark xiv. 50.

Isa. liii. 3.

13 I became a reproof among all mine enemies, but especially among my neighbours : and they of mine acquaintance were afraid of me, and they that did see me without conveyed themselves from me.

14 I am clean forgotten, as a dead man out of mind : I am become like a broken vessel.

Matt. xxvi. 66.
xxvii. 22. 25.
40.

15 For I have heard the blasphemy of the multitude : and fear is on every side, while they conspire together against me, and take their counsel to take away my life.

John xvii. 25.

16 But my hope hath been in thee, O Lord : I have said, Thou art my God.

Luke xxii. 42.

17 My time is in thy hand, deliver me from the hand of mine enemies : and from them that persecute me.

18 Shew thy servant the light of thy countenance : and save me for thy mercy sake.

Te Deum.

19 Let me not be confounded, O Lord, for I have called upon thee : let the ungodly be put to confusion, and be put to silence in the grave.

Matt. xxvi. 60.
68.

20 Let the lying lips be put to silence : which cruelly, disdainfully, and despitefully speak against the righteous.

21 O how plentiful is thy goodness which thou hast laid up for them that fear thee : and that thou hast prepared for them that put their trust in thee, even before the sons of men.

Isa. xxxii. 2.
iv. 6.

22 Thou shalt hide them privily by thine own presence from the provoking of all men : thou shalt keep them secretly in thy tabernacle from the strife of tongues.

Super omnes inimicos meos factus sum opprobrium vicinis meis valde : vic. meis nimium et timor notis meis.

Qui videbant me foras fugerunt a me : oblivioni datus sum, tanquam mortuus a corde.

Factus sum tanquam vas perditum : quoniam audivi vituperationem multorum commorantium in circuitu.

In eo dum convenirent simul adversum me : accipere animam meam consiliati sunt.

Ego autem in te speravi, Domine ; dixi, Deus meus es tu : in manibus tuis sortes meae.

Eripe me de manu inimicorum meorum : et a persequentibus me.

Illustra faciem tuam super servum tuum, salvum me fac in misericordia tua, Domine : non confundar, quoniam invocavi te.

Erubescant impii, et deducantur in infernum : muta fiant labia dolosa.

Quae loquuntur adversus justum iniquitatem : in superbia, et in abusione.

Quam magna multitudo dulcedinis tuae Domine : quam abscondisti timentibus te ?

Perfecisti eis qui sperant in te : in conspectu filiorum hominum.

Abscondes eos in abscondito faciei tuae : a conturbatione hominum.

Proteges eos in tabernaculo tuo : a contradictione linguarum.

said to the persecutor of His Church, "Saul, Saul, why persecutest thou Me?" and so He will say at the last day, "Inasmuch as ye did it unto one of the least of these My brethren, ye did it unto Me."

In psalms and prophecies we may find the Scriptural complement of the Gospels, revealed by Him who could foresee history. So in the eleventh verse of this Psalm we have a most affecting truth concerning the influence of Christ's sorrows on His human nature. His earthly life extended only to thirty-three years, yet He seemed so much older that the Jews said to Him, "Thou art not yet fifty years old." The truth is here told us, that His "life was waxen old through heaviness, and his years with mourning;" youth and joy having no place in the ministerial life of Him who saw and felt the whole accumulated burden of all sin.

The direct application of this Psalm to our Lord is thus as

clearly shown as in any of those which are more especially named as Psalms of the Passion; nor can a complete application be made to any other person, or to Him in any other manner than as representing those for whom His work of atonement was wrought. The whole Psalm is an amplification of our Lord's prayer, "Not My will, but Thine;" and sets before us very strongly the necessity and the advantage of prayer. For if He uttered such words of prayer for deliverance Who knew the whole course of events that was to follow, how much more are they bound to supplicate their God to whom the future is a sealed book. And if the Lord heard the voice of the Saviour's prayer [verse 25], and sent an angel to strengthen Him though the cup of the Passion was not removed, much more may they look to be made strong, and to have their hearts established, who are in so much greater need of the Divine aid.

Few Psalms contain more verses which can be taken into use

The VI. Day.
Morning
Prayer.
Isa. xxvi. 1.

23 Thanks be to the Lord : for he hath shewed me marvellous great kindness in a strong city.

Cf. Isa. xxxviii. 10, 11.
Mark xv. 34.

24 And when I made haste, I said : I am cast out of the sight of thine eyes.

25 Nevertheless thou heardest the voice of my prayer : when I cried unto thee.

26 O love the Lord, all ye his saints : for the Lord preserveth them that are faithful, and plenteously rewardeth the proud doer.

Luke xxii. 43.
Isa. xl. 31.
Jer. xvii. 7.

27 Be strong, and he shall establish your heart : all ye that put your trust in the Lord.

THE XXXII PSALM.

Beati, quorum.

Evening
Prayer.
Ash-Wednesday
Mattins.
Penitential
Psalm.
Rom. iv. 16.
James v. 20.
1 Pet. ii. 22.

BLESSED is he whose unrighteousness is forgiven : and whose sin is covered.

2 Blessed is the man unto whom the Lord imputeth no sin : and in whose spirit there is no guile.

Isa. lvii. 20.

3 For while I held my tongue : my bones consumed away through my daily complaining.

4 For thy hand is heavy upon me day and night : and my moisture is like the drought in summer.

5 I will acknowledge my sin unto thee : and mine unrighteousness have I not hid.

2 Sam. xii. 13.
Luke vi. 20-24.

6 I said, I will confess my sins unto the Lord : and so thou forgavest the wickedness of my sin.

7 For this shall every one that is godly make his prayer unto thee, in a time when thou mayest be found : but in the great water-floods they shall not come nigh him.

Benedictus Dominus : quoniam mirificavit misericordiam suam mihi ; in civitate munita. suam in cib. circumstantia

Ego autem dixi in excessu mentis meæ : Projectus sum a facie oculorum tuorum. in pavore meo . . . a vultu

Ideo exaudisti vocem orationis meæ : dum clamarem ad te. deprecationis

Diligite Dominum omnes sancti ejus, quoniam veritatem requiret Dominus : et retribuet abundanter facientibus superbiam. ret. his qui abundanter faciunt sup.

Viriliter agite, et confortetur cor vestrum : omnes qui speratis in Domino.

PSALMUS XXXI.

BEATI quorum remissæ sunt iniquitates : et quorum tecta sunt peccata. Mond. Mattins.

Beatus vir cui non imputavit Dominus peccatum : nec est in spiritu ejus dolus. imputabit in ore

Quoniam tacui, inveteraverunt ossa mea : dum clamarem tota die. omnia ossa

Quoniam die ac nocte gravata est super me manus tua : conversus sum in ærumna mea, dum configitur spina. confringitur

Delictum meum cognitum tibi feci : et iniquitiam meam non abscondi. injustitias meas non operui

Dixi, Confitebor adversum me iniquitiam meam Domino : et tu remisisti impietatem peccati mei. Pronuntiabo . . . injustitias meas

Pro hac orabit ad te omnis sanctus : in tempore opportuno. impietatem cordis mei

Veruntamen in diluvio aquarum multarum : ad eum non approximabunt.

by the Christian as expressive of his own experience and aspirations. As our Lord left to His people the germ of all prayer, so He has consecrated the words of David by His own adoption of them, and that in such a manner that we may use them as part of His own prevailing intercession.

PSALM XXXII.

Christ, as the representative of the whole human race, offers up in this Psalm the sacrifice of penitence, and rejoices in the blessedness of Absolution. So "blessed" indeed was He by the purity of His nature that no sin was imputed to Him as His own, nor was any guile found in His spirit. Yet so great is the mercy of God that the blessedness of the forgiven soul is made next, and even like to, that of the innocent soul. When His

pardoning word has exercised its power, and "unrighteousness is forgiven," the spirit is freed, and pure of guile and sin ; so that they who are thus reunited to the spotless Lamb of God become partakers of His holiness.

Thus, although there is no peace to the sinner while he holds his tongue, and refuses to confess his sin, he who puts his trust in the Lord's mercy and humbly acknowledges his transgressions will find that mercy embracing him on every side. Especially he will find out that the Son of Man hath power on earth to forgive sins, and that this power He has given to His Church [John xx. 23] ; that when "truth of heart," a sincere penitence, has removed every bar from the way of God's word of absolution, it will go forth with power to convey actual pardon, and, with pardon, comfort.

The VI. Day.
Evening
Prayer.
Isa. xxxii. 2.

8 Thou art a place to hide me in,
thou shalt preserve me from trouble :
thou shalt compass me about with
songs of deliverance.

9 I will inform thee, and teach thee
in the way wherein thou shalt go : and
I will guide thee with mine eye.

10 Be ye not like to horse and
mule, which have no understanding :
whose mouths must be held with bit
and bridle, lest they fall upon thee.

11 Great plagues remain for the
ungodly : but whose putteth his trust
in the Lord, mercy embraceth him on
every side.

John xvi. 22.
Rev. vii. 14.

12 Be glad, O ye righteous, and
rejoice in the Lord : and be joyful,
all ye that are true of heart.

THE XXXIII PSALM.

Exultate, justi.

Rev. xix. 7.
James v. 13.

REJOICE in the Lord, O ye right-
eous : for it becometh well the
just to be thankful.

2 Praise the Lord with harp : sing
praises unto him with the lute, and
instrument of ten strings.

Rev. v. 9.

3 Sing unto the Lord a new song :
sing praises lustily unto him with a
good courage.

4 For the word of the Lord is true :
and all his works are faithful.

5 He loveth righteousness and
judgement : the earth is full of the
goodness of the Lord.

Rev. iv. 11.
John i. 3.
Gen. i. 2.

6 By the word of the Lord were
the heavens made : and all the hosts
of them by the breath of his mouth.

Gen. i. 9.
Rev. xxi. 1.

7 He gathereth the waters of the
sea together, as it were upon an heap :
and layeth up the deep, as in a trea-
sure-house.

Ezek. xxxviii. 20.

8 Let all the earth fear the Lord :
stand in awe of him, all ye that dwell
in the world.

Tu es refugium meum a tribulatione ^{a pressura}
quæ circundedit me : exultatio mea,
erue me a circulantibus me. redime

Intellectum tibi dabo, et instruam
te in via hac qua gradieris : firmabo ^{ingredieris}
super te oculos meos.

Nolite fieri sicut equus et mulus :
quibus non est intellectus.

In chamo et fræno maxillas eorum
constringe : qui non approximant ad te.

Multa flagella peccatoris : speran- ^{peccatorum : spe-}
tem autem in Domino misericordia ^{rantes}
circundabit.

Lætamini in Domino et exultate
justi : et gloriamini omnes recti corde.

PSALMUS XXXII.

EXULTATE justi in Domino : ^{Mond. Mattins.}
rectos decet collaudatio. ^{Many Martyrs,}
^{3rd Noct.}
^{[See S. Aug. Serm.}
^{335.]}
^{Gaudete}

Confitemini Domino in cithara : in
psalterio decem chordarum psallite illi.

Cantate ei canticum novum : bene
psallite ei in vociferatione. in jubilatione

Quia rectum est verbum Domini : ^{Quoniam rectus}
et omnia opera ejus in fide. ^{est sermo}

Diligit misericordiam et judicium :
misericordia Domini plena est terra.

Verbo Domini caeli firmati sunt : et
spiritu oris ejus omnis virtus eorum.

Congregans sicut in utre aquas ^{in utrem}
maris : ponens in thesauris abyssos. ^e

Timeat Dominum omnis terra : ab
eo autem commoveantur omnes inha- ^{universi et omnes}
bitantes orbem. ^{qui inhabitant}

This penitential Psalm is, therefore, a word of Christ showing us the pattern of repentance to be followed by His members, and proclaiming the blessedness of their state whose repentance has been of that sincere character that God is able to bless to the penitent the words of absolution, and thus to make them effective to his pardon and justification.

PSALM XXXIII.¹

This Psalm has been used time immemorial on festivals of

¹ The structure of this Psalm is observable, consisting as it does of an introductory and concluding verse, and of nine intermediate stanzas or

martyrs. It was, doubtless, adopted for that purpose from its manifest position as a sequel to the foregoing Psalm of penitence ; which makes it represent the "New Song" of the saints who have entered into perfect peace through the final pardon of their God : "And they sung a new song, saying, Thou art worthy to take the book, and to open the seals thereof : for Thou wast slain, and hast redeemed us to God by Thy blood out of every kindred, and tongue, and people, and nation ; and hast made us

subjects. It can scarcely be doubted that this structure was recognized in the music to which the Psalm was originally sung. It is also probable that there is a reference to it in the end of the second verse.

The VI. Day.
Evening
Prayer.
Gen. i. 3.
Job v. 12.

9 For he spake, and it was done :
he commanded, and it stood fast.

10 The Lord bringeth the counsel
of the heathen to nought : and maketh
the devices of the people to be of none
effect, and casteth out the counsels of
princes.

Isa. xl. 8.
xlv. 10.

11 The counsel of the Lord shall
endure for ever : and the thoughts of
his heart from generation to genera-
tion.

John xv. 16.

12 Blessed are the people whose
God is the Lord Jehovah : and blessed
are the folk that he hath chosen to
him, to be his inheritance.

13 The Lord looked down from
heaven, and beheld all the children of
men : from the habitation of his dwell-
ing he considereth all them that dwell
on the earth.

14 He fashioneth all the hearts of
them : and understandeth all their
works.

Numb. xiv. 44.
Judges vii. 4.
2 Sam. xxiv. 1.

15 There is no king that can be
saved by the multitude of an host :
neither is any mighty man delivered
by much strength.

Deut. xvii. 16.
Isa. xxx. 16.

16 A horse is counted but a vain
thing to save a man : neither shall
he deliver any man by his great
strength.

Luke xxii. 61.

17 Behold, the eye of the Lord is
upon them that fear him : and upon
them that put their trust in his
mercy ;

18 To deliver their soul from
death : and to feed them in the time
of dearth.

Luke viii. 15.
xxi. 19.
Rev. xiii. 30.

19 Our soul hath patiently tarried
for the Lord : for he is our help, and
our shield.

20 For our heart shall rejoice in
him : because we have hoped in his
holy Name.

Dan. iii. 8.

21 Let thy merciful kindness, O
Lord, be upon us : like as we do put
our trust in thee.

Quoniam ipse dixit, et facta sunt :
ipse mandavit, et creata sunt.

Dominus dissipat consilia gentium ;
reprobat autem cogitationes populo-
rum : et reprobat consilia principum.

Consilium autem Domini in æter-
num manet : cogitationes cordis ejus
in generatione et generationem.

in sæculum sæculi

Beata gens cujus est Dominus Deus
ejus : populus quem elegit in hæredi-
tatem sibi.

De cælo respexit Dominus : vidit
omnes filios hominum.

De præparato habitaculo suo : re-
spexit super omnes qui habitant ter-
ram.

Qui fixit singillatim corda eorum :
qui intelligit omnia opera eorum.

Non salvatur rex per multam vir-
tutem : et gigas non salvabitur in
multitudine virtutis suæ.

*salvus erit in mul-
titudine forti-
tudinis suæ*

Fallax equus ad salutem : in abun-
dantia autem virtutis suæ non salva-
bitur.

*Falsus . . . non
erit salvus*

Ecce oculi Domini super metuentes
eum : et in eis qui sperant super mise-
ricordia ejus.

*timentes eum spe-
rantes autem in
misericordia
ejus*

Ut eruat a morte animas eorum : et eripiat
alut eos in fame.

Anima nostra sustinet Dominum :
quoniam adjutor et protector noster
est.

autem nostra

Quia in eo lætabitur cor nostrum :
et in nomine sancto ejus speravimus.

spera bimus

Fiat misericordia tua, Domine, super
nos : quemadmodum speravimus in te.

sicut

unto our God, kings and priests: and we shall reign on the earth." [Rev. v. 9, 10.] This association of ideas is further exhibited by the general subject of the Psalm, which is a hymn of praise to God for the wonders of Creation, it being one of the strains of heavenly lauds that "Thou art worthy, O Lord, to receive glory, and honour, and power: for Thou hast created all things, and for Thy pleasure they are and were created." [Rev. iv. 11.]

But all such hymns of praise for God's good work in the natural creation carry a further meaning which looks to the new and spiritual Creation whereby all things are made new in Christ Jesus. By the word of the Lord were the heavens made: and the same word will be the Creator of the new heaven and the new earth, when the first heaven and the first earth shall have passed away and there shall be no more sea. The Church enlightened by the words of Christ and the Holy Ghost sings

THE XXXIV PSALM.

Benedicam Domino.

The VI. Day.
Evening
Prayer.

I WILL always give thanks unto the Lord : his praise shall ever be in my mouth.

2 My soul shall make her boast in the Lord : the humble shall hear thereof, and be glad.

3 O praise the Lord with me : and let us magnify his Name together.

4 I sought the Lord, and he heard me : yea, he delivered me out of all my fear.

5 They had an eye unto him, and were lightened : and their faces were not ashamed.

Luke xxii. 43.

6 Lo, the poor crieth, and the Lord heareth him : yea, and saveth him out of all his troubles.

7 The angel of the Lord tarrieth round about them that fear him : and delivereth them.

John vi. 55.
2 Cor. v. 17.

8 O taste, and see how gracious the Lord is : blessed is the man that trusteth in him.

9 O fear the Lord, ye that are his saints : for they that fear him lack nothing.

10 The lions do lack, and suffer hunger : but they who seek the Lord shall want no manner of thing that is good.

11 Come, ye children, and hearken unto me : I will teach you the fear of the Lord.

1 Pet. iii. 10.

12 What man is he that lusteth to live : and would fain see good days ?

13 Keep thy tongue from evil : and thy lips, that they speak no guile.

1 Pet. iii. 11.

14 Eschew evil, and do good : seek peace, and ensue it.

PSALMUS XXXIII.

BENEDICAM Dominum in omni tempore : semper laus ejus in ore meo.

Mond. Mattins.
Many Martyrs,
3rd Noct.
St. Michael and
All Saints,
2nd Noct.
App. and Evv.,
1st Noct.

In Domino laudabitur anima mea : audiant mansueti, et lætentur.

Magnificate Dominum mecum : et exaltemus nomen ejus in idipsum. *in invicem*

Exquisivi Dominum, et exaudivit me : et ex omnibus tribulationibus meis eripuit me.

Accedite ad eum, et illuminamini : et faciès vestræ non confundentur. *vultus vestri non erubescunt*

Iste pauper clamavit, et Dominus exaudivit eum : et ex omnibus tribulationibus ejus salvavit eum. *liberavit*

Immittet angelus Domini in circuitu timentium eum : et eripiet eos. *Immittit angelum Dominus*

Gustate, et videte quoniam suavis est Dominus : beatus vir qui sperat in eo.

Timete Dominum omnes sancti ejus : quoniam non est inopia timentibus eum. *nihil deest*

Divites eguerunt et esurierunt : inquirentes autem Dominum non minuentur omni bono. *deficient*

Venite, filii, audite me : timorem Domini docebo vos.

Quis est homo qui vult vitam : diligite dies videre bonos ? *et cupit*

Prohibe linguam tuam a malo : et labia tua ne loquantur dolum. *cohibe*

Diverte a malo et fac bonum : inquire pacem, et persequere eam.

this hymn to God with a far deeper meaning than attached to it when sung by the Jewish Church : beholding with open face the glory of the Lord Jesus revealed in it ; and adoring Him in its measured strains as that eternal WORD, Who became man for us men and for our salvation, and Whose perpetual miracle of new creation is the subject of her continual thanksgiving.

PSALM XXXIV.¹

This Psalm contains a Divine prophecy of the Agony, Suffering,

¹ This Psalm is directed to be used at the time of Communion in the Liturgy of St. James, and in the Apostolical Constitutions. The association of it with the Eucharist plainly arises from the words of the eighth verse. In the Hebrew it is an alphabet Psalm.

and Deliverance of the holy Jesus ; and also of the fate of Judas the betrayer : " Great are the troubles of the righteous. . . . But they that hate the righteous shall be desolate." In the third verse there is a direct recognition of the principle that Christ's words in the Psalms are also often given to be the words of His members ; and in the sixth and seventh verses this principle is illustrated by the change of the pronoun from singular to plural. The " poor in spirit " are one with Him who became " THE POOR " that He might make many rich. He cried to His Father when His soul was exceeding sorrowful, even unto death, and the angel of the Lord appeared from Heaven, strengthening Him. Our Lord is also called " THE RIGHTEOUS " (the term being used interchangeably in the same manner) in the fifteenth, seventeenth, and nineteenth verses. This term is found in Acts iii. 14,

The VI. Day
Evening
Prayer.
1 Pet. iii. 12.

15 The eyes of the Lord are over the righteous : and his ears are open unto their prayers.

16 The countenance of the Lord is against them that do evil : to root out the remembrance of them from the earth.

Luke xxiii. 34, 46.

17 The righteous cry, and the Lord heareth them : and delivereth them out of all their troubles.

18 The Lord is nigh unto them that are of a contrite heart : and will save such as be of an humble spirit.

Acts iii. 14.
vii. 52.

19 Great are the troubles of the righteous : but the Lord delivereth him out of all.

Exod. xii. 46.
John xix. 36.
Isa. liii. 7.

20 He keepeth all his bones : so that not one of them is broken.

Matt. xxvii. 5.
Ps. lxi. 25.
Acts i. 20.

21 But misfortune shall slay the ungodly : and they that hate the righteous shall be desolate.

22 The Lord delivereth the souls of his servants : and all they that put their trust in him shall not be destitute.

THE XXXV PSALM.

Judica, Domine.

The VII. Day.
Morning
Prayer.

PLEAD thou my cause, O Lord, with them that strive with me : and fight thou against them that fight against me.

2 Lay hand upon the shield and buckler : and stand up to help me.

3 Bring forth the spear, and stop the way against them that persecute me : say unto my soul, I am thy salvation.

Oculi Domini super justos : et aures ejus ad preces eorum.

Vultus autem Domini super facientes mala : ut perdat de terra memoriam eorum.

Clamaverunt justi, et Dominus exaudivit eos : et ex omnibus tribulationibus eorum liberavit eos.

Juxta est Dominus his, qui tribulatio tribulati sunt corde : et humiles spiritu salvabit.

Multas tribulationes justorum : et de omnibus his liberavit eos Dominus. liberabit

Custodit Dominus omnia ossa eorum : unum ex his non conteretur.

Mors peccatorum pessima : et qui oderunt justum delinquent.

Redimet Dominus animas servorum suorum : et non delinquent omnes qui sperant in eo.

PSALMUS XXXIV.

JUDICA, Domine, nocentes me : Mond. Mattins.
expugna impugnantes me.

Apprehende arma et scutum : et exsurge in adjutorium mihi.

Effunde frameam, et conclude adversus eos qui persequuntur me : dic animæ meæ, Salus tua ego sum.

and vii. 52, and the twentieth verse being expressly applied to our Lord by St. John, shows clearly of whom the Psalm speaks. In contrast to this designation of the holy Jesus, "the Ungodly" must clearly be taken to mean the betrayer, whom "misfortune slew" when "he hanged himself and falling headlong he burst asunder in the midst and his bowels gushed out," and of whom the Apostle said, "Let his habitation be desolate." Hence we may see that the "evil" of the traitor's "tongue," and the "guile" of his "Hail, Master," are signified in the thirteenth and fourteenth verses, setting him forth as a terrible example, and warning us that it is possible even now to crucify the Son of God afresh.

In the eleventh verse we seem to hear the parting words of the great Teacher to His little flock, "I will not leave you orphans:" the echo of which loving words sounded in the oft-repeated salutation of His beloved Apostle, "My little children." Of that little flock, the children of the Lord, the words of the Psalm are also spoken; of the Bride which is "bone of His bone, and flesh of His flesh," and which He will preserve through all the troubles of this world, that though her blood be even shed like water in the streets of Jerusalem, the strength of her internal

frame shall survive to be restored to life in the glory of the Resurrection kingdom.

PSALM XXXV.

A Scriptural key to the Evangelical interpretation of this Psalm is given by our Lord Himself in one of His final discourses: "But this is come to pass that the word might be fulfilled that is written in their law, They hated Me without a cause." [John xv. 25.] The eleventh verse also received a literal fulfilment in the false witness borne against our Lord when He was accused before the High Priest. And, like the preceding Psalm, it contains, in addition to these direct references to the sufferings of our Lord, a prophetic intimation of the fate which should befall the traitor Judas.

Although bearing much resemblance to the twenty-second Psalm in its general character, this differs from that in dwelling less upon the sorrows of the suffering Jesus as they affected His body and soul than on the aspect which those sorrows wear as being brought about by the acts of those whom He came to love and save. In the one Psalm the Man of sorrows is heard crying

<p>The VII. Day. Morning Prayer. See Ps. lxiix. notes.</p>	<p>4 Let them be confounded, and put to shame, that seek after my soul : let them be turned back, and brought to confusion, that imagine mischief for me.</p>	<p>Confundantur et revereantur : quæ <small>inimici mei qui querunt</small> rentes animam meam. Avertantur retrorsum et confundantur : cogitantes mihi mala. <small>erubescant qui cogitant</small></p>
<p>Matt. xxi. 43.</p>	<p>5 Let them be as the dust before the wind : and the angel of the Lord scattering them.</p>	<p>Fiant tanquam pulvis ante faciem venti : et angelus Domini coarctans <small>adfigens eos</small> eos.</p>
<p>Matt. xxiii. 35-38.</p>	<p>6 Let their way be dark and slippery : and let the angel of the Lord persecute them.</p>	<p>Fiat via illorum tenebræ et lubricum : et angelus Domini persequens eos.</p>
<p>John xv. 25.</p>	<p>7 For they have privily laid their net to destroy me without a cause : yea, even without a cause have they made a pit for my soul.</p>	<p>Quoniam gratis absconderunt mihi interitum laquei sui : supervacue ex- <small>vane</small> probaverunt animam meam.</p>
<p>Acts i. 18.</p>	<p>8 Let a sudden destruction come upon him unawares, and his net, that he hath laid privily, catch himself : that he may fall into his own mischief.</p>	<p>Veniat illi laqueus quem ignorat : <small>ignorant . . . occultaverunt . . . eos . . . incidant in ipso</small> et captio quam abscondit apprehendat eum, et in laqueum cadat in ipsum.</p>
	<p>9 And, my soul, be joyful in the Lord : it shall rejoice in his salvation.</p>	<p>Anima autem mea exultabit in Domino : et delectabitur super salutari suo.</p>
	<p>10 All my bones shall say, Lord, who is like unto thee, who deliverest the poor from him that is too strong for him : yea, the poor, and him that is in misery, from him that spoileth him.</p>	<p>Omnia ossa mea dicent : Domine, quis similis tibi ? Eripiens inopem de manu fortiorum ejus : egenum et pauperem a diripien- <small>rapientibus</small> tibus eum.</p>
<p>Matt. xxvi. 60.</p>	<p>11 False witnesses did rise up : they laid to my charge things that I knew not.</p>	<p>Surgentes testes iniqui : quæ ignorabam interrogabant me.</p>
	<p>12 They rewarded me evil for good : to the great discomfort of my soul.</p>	<p>Retribuebant mihi mala pro bonis : sterilitatem animæ meæ.</p>
<p>John i. 14. Luke iv. 2. Heb. ii. 17, 18. Job xvi. 15.</p>	<p>13 Nevertheless, when they were sick I put on sackcloth, and humbled my soul with fasting : and my prayer shall turn into mine own bosom.</p>	<p>Ego autem cum mihi molesti essent : induebar cilicio. <small>induebam me</small> Humiliabam in jejunio animam meam : et oratio mea in sinu meo convertetur.</p>
<p>Mark iii. 35. Matt. xxvi. 50. Jer. iii. 1.</p>	<p>14 I behaved myself as though it had been my friend, or my brother : I went heavily as one that mourneth for his mother.</p>	<p>Quasi proximum, et quasi fratrem <small>Sicut proximum sicut . . . ita . . . tanquam . . . ita</small> nostrum, sic complacebam : quasi lugen- et contristatus, sic humiliabar.</p>
<p>Isa. l. 6. Luke xxiii. 39. Matt. xxvii. 39.</p>	<p>15 But in mine adversity they rejoiced, and gathered themselves together : yea, the very abjects came together against me unawares, making mouths at me, and ceased not.</p>	<p>Et adversum me lætati sunt, et convenerunt : congregata sunt super me <small>congregaverunt in me flagella et ignoraverunt</small> flagella, et ignoravi.</p>

out in the depth of the woe brought upon Him by His vicarious atonement : in the other, the guileless Just One appeals to the All-righteous Judge against the unrighteous judgment of men. "Judge Me, O Lord, according to Thy righteousness." In this aspect the thirty-fifth Psalm furnishes us with a fearful comment upon the injustice of the Jews in persecuting Christ. And since, when He cries "Plead Thou *My* cause," He asks the righteous Judge to plead that of His mystical Body also, the Psalm

expresses not less the injustice of those who at any time persecute the Church. In the one case we see the manner in which the world treated the Good Samaritan who put on the sackcloth of our nature that He might lift up that nature, sick and wounded by the Fall : in the other the Antichrists of every age rising up in false witness, and spreading nets against His Church, the one mission of which is to gather souls to God. In both the appeal lies from the injustice of earth to the righteousness of

The VII. Day.
Morning
Prayer.
Job xvi. 10.
Matt. xxvii. 40.
Isa. xxxvii. 23.
Rev. vi. 10.

16 With the flatterers were busy mockers : who gnashed upon me with their teeth.

17 Lord, how long wilt thou look upon this : O deliver my soul from the calamities which they bring on me, and my darling from the lions.

Isa. liii. 11.
Rev. vii. 9.

18 So will I give thee thanks in the great congregation : I will praise thee among much people.

John xv. 25.
Ps. lxix. 4.

19 O let not them that are mine enemies triumph over me ungodly : neither let them wink with their eyes that hate me without a cause.

20 And why? their communing is not for peace : but they imagine deceitful words against them that are quiet in the land.

Matt. xxvii. 39.

21 They gaped upon me with their mouth, and said : Fie on thee, fie on thee, we saw it with our eyes.

22 This thou hast seen, O Lord : hold not thy tongue then, go not far from me, O Lord.

Rev. vi. 10.

23 Awake and stand up to judge my quarrel : avenge thou my cause, my God and my Lord.

24 Judge me, O Lord my God, according to thy righteousness : and let them not triumph over me.

25 Let them not say in their hearts, There, there, so would we have it : neither let them say, we have devoured.

al. devoured him.

Rev. xi. 10.

26 Let them be put to confusion and shame together that rejoice at my trouble : let them be clothed with rebuke and dishonour that boast themselves against me.

27 Let them be glad and rejoice that favour my righteous dealing : yea, let them say alway, Blessed be the Lord, who hath pleasure in the prosperity of his servant.

28 And as for my tongue, it shall be talking of thy righteousness : and of thy praise all the day long.

Dissipati sunt, nec compuncti ; tentaverunt me ; subsannaverunt me subsannatione : frenduerunt super me dentibus suis. Dissoluti . . . tentaverunt me et diriserunt derisus striderunt in me dent. suis

Domine, quando respicies? restitue animam meam a malignitate eorum : malefactorum a leonibus unicam meam.

Confitebor tibi in ecclesia magna : tibi Domine in populo gravi laudabo te.

Non supergaudeant mihi qui adversantur mihi inique : qui oderunt me gratis, et annuunt oculis. ut non insultent in me annuebunt

Quoniam mihi quidem pacifice loquebantur : et in iracundia terræ loquentes dolos cogitabant. super tram dolos cog.

Et dilataverunt super me os suum : dixerunt, Euge, euge, viderunt oculi nostri.

Vidisti, Domine, ne sileas : Domine, ne discedas a me.

Exsurge et intende iudicio meo Deus meus : et Dominus meus in causam meam. Ex. Domine

Judica me secundum justitiam tuam, Domine Deus meus : et non supergaudeant mihi. me Domine . . . misericordiam . . . et non insultent in me inimici mei

Non dicant in cordibus suis, Euge, euge, animæ nostræ : nec dicant, Devorabimus eum. Absorbimus

Erubescant et vereantur simul : qui gratulantur malis meis.

Induantur confusione et reverentia : qui maligna loquuntur super me. rudore et magna loq. . . . adversum me

Exultent et lætentur qui volunt justitiam meam : et dicant semper, Magnificetur Dominus, qui voluit pacem servi ejus.

Et lingua mea meditabitur justitiam tuam : tota die laudem tuam. Sed et

Heaven : "How long, O Lord, holy and true, dost Thou not judge and avenge our blood on them that dwell on the earth?" And the Church of the Redeemer can look forward as her Lord did, with faith in the righteous verdict of her God and in His avenging hand : looking, for the destruction not of foes, but of the enmity and sin of foes : looking for them to be so conquered and brought to shame that they may be clothed with the

rebuke and dishonour of true penitence, and afterwards be among the number of those that sing, "Blessed be the Lord, Who hath pleasure in the prosperity of His servant."

Some remarks applying to the imprecatory tone of the first eight verses will be found in the notes to the sixty-ninth Psalm.

THE XXXVI PSALM.

Dixit injustus.

The VII. Day.
Morning
Prayer.
Rom. iii. 23.
2 Thess. ii. 8.
Gen. iii. 6.

MY heart sheweth me the wickedness of the ungodly : that there is no fear of God before his eyes.

2 For he flattereth himself in his own sight : until his abominable sin be found out.

3 The words of his mouth are unrighteous, and full of deceit : he hath left off to behave himself wisely, and to do good.

Cf. Ps. i. 2.
lxiii. 7.

4 He imagineth mischief upon his bed, and hath set himself in no good way : neither doth he abhor any thing, that is evil.

Rom. vii. 24.
xi. 33.
Isa. i. 18.

5 Thy mercy, O Lord, reacheth unto the heavens : and thy faithfulness unto the clouds.

Ecclesi. xxiv. 29.

6 Thy righteousness standeth like the strong mountains : thy judgements are like the great deep.

Jonah iv. 11.
Zech. ii. 4.
Deut. xxxi. 11,
12.
Matt. xxiii. 37.

7 Thou, Lord, shalt save both man and beast ; How excellent is thy mercy, O God : and the children of men shall put their trust under the shadow of thy wings.

Rev. xxii. 1.

8 They shall be satisfied with the plenteousness of thy house : and thou shalt give them drink of thy pleasures as out of the river.

John iv. 14.
John i. 4. 9. viii.
12. xii. 36.
Rev. xxi. 11. 23.

9 For with thee is the well of life : and in thy light shall we see light.

10 O continue forth thy loving-kindness unto them that know thee : and thy righteousness unto them that are true of heart.

2 Thess. ii. 3.

11 O let not the foot of pride come against me : and let not the hand of the ungodly cast me down.

2 Thess. i. 7-10.
Rev. xix. 11.
xx. 15. xxi. 27.

12 There are they fallen, all that work wickedness : they are cast down, and shall not be able to stand.

PSALMUS XXXV.

DIXIT injustus ut delinquat in semetipso : non est timor Dei ante oculos ejus.

Quoniam dolose egit in conspectu ejus : ut inveniatur iniquitas ejus ad odium.

Verba oris ejus iniquitas et dolus : noluit intelligere ut bene ageret.

Iniquitatem meditatus est in cubili suo : astitit omni viæ non bonæ ; malitiam autem non odivit.

Domine, in cælo misericordia tua : et veritas tua usque ad nubes.

Justitia tua sicut montes Dei : judicia tua abyssus multa.

Homines et jumenta salvabis, Domine : quemadmodum multiplicasti misericordiam tuam, Deus.

Filii autem hominum : in tegmine alarum tuarum sperabunt.

Inebriabuntur ab ubertate domus tuæ : et torrente voluptatis tuæ potabis eos.

Quoniam apud te fons vitæ : et in lumine tuo videbimus lumen.

Prætede misericordiam tuam scientibus te : et justitiam tuam his qui recto sunt corde.

Non veniat mihi pes superbiæ : et manus peccatoris non moveat me.

Ibi ceciderunt qui operantur iniquitatem : expulsi sunt, nec potuerunt stare.

PSALM XXXVI.¹

The first four verses of this Psalm set forth the condition of fallen man ; the latter verses proclaim the mercy of God in the dispensation of grace from the "Fountain" of our Lord's immaculate human nature which was "opened for all uncleanness."

"The fear of God," that fear which proceeds from love and not from terror, was lost by the Fall ; the "flattery" of himself by the sinner was shown by the attempt to veil the shame which

¹ In the indictment of criminals, a form of words is used which is taken from the first verse of this Psalm, viz. "not having the fear of God before his eyes."

came with the knowledge of evil : the excuses which the sinners made to God were unrighteous and full of deceit ; they had left off to behave themselves wisely, and tried to hide themselves from their all-seeing Creator : good became alien to them instead of being natural ; and they had lost the hatred of disobedience and sin with which they had originally been endowed. All this was typical of sin and sinners at all times ; and at all times God's mercy to the sinner is immeasurable, immovable, and inexhaustible. Such is the signification underlying the first half of the Psalm. Then we praise God that "when there was none to help, His arm brought salvation" [Isa. lxiii. 5], and that His love gathered sinners to Himself "like as a hen gathereth her

THE XXXVII PSALM.

Noli æmulari.

The VII. Day.
Evening
Prayer.

FRET not thyself because of the
ungodly : neither be thou envious
against the evildoers.

Rev. xiv. 19.
Matt. xiii. 30, 40.

2 For they shall soon be cut down
like the grass : and be withered even
as the green herb.

Matt. v. 3, 6.
vi. 33.

3 Put thou thy trust in the Lord,
and be doing good : dwell in the
land, and verily thou shalt be fed.

Luke vii. 47.

4 Delight thou in the Lord : and
he shall give thee thy heart's desire.

1 Pet. v. 7.
1 John iii. 22.

5 Commit thy way unto the Lord,
and put thy trust in him : and he
shall bring it to pass.

6 He shall make thy righteousness
as clear as the light : and thy just
dealing as the noon-day.

Luke xxi. 19.
Rev. xiii. 10.
xiv. 12.

7 Hold thee still in the Lord, and
abide patiently upon him : but grieve
not thyself at him whose way doth
prosper, against the man that doeth
after evil counsels.

Eph. iv. 31.

8 Leave off from wrath, and let go
displeasure : fret not thyself, else shalt
thou be moved to do evil.

James v. 7.

9 Wicked doers shall be rooted out :
and they that patiently abide the
Lord, those shall inherit the land.

Rev. xxi. 27.

10 Yet a little while, and the un-
godly shall be clean gone : thou shalt
look after his place, and he shall be
away.

Matt. v. 5.

11 But the meek-spirited shall pos-
sess the earth : and shall be refreshed
in the multitude of peace.

Matt. xxvii. 1.
Acts iii. 14.
iv. 27.

12 The ungodly seeketh counsel
against the just : and gnasheth upon
him with his teeth.

Heb. x. 37.

13 The Lord shall laugh him to
scorn : for he hath seen that his day
is coming.

PSALMUS XXXVI.

NOLI æmulari in malignantibus :
neque zelaveris facientes iniqui-
tatem.

Mond. Mattins.
*inter malignantes
neque æmulatus
fueris*

Quoniam tanquam fœnum velociter
arescent : et quemadmodum olera her-
barum cito decident.

sicut . . . cadent

Spera in Domino, et fac bonitatem :
et inhabita terram, et pasceris in di-
vitiis ejus.

Delectare in Domino : et dabit tibi
petitiones cordis tui.

Revela Domino viam tuam : et spera
in eo, et ipse faciet.

in eum

Et educet quasi lumen justitiam
tuam, et judicium tuum tanquam me-
ridiem : subditus esto Domino, et ora
eum.

*tanquam . . . sicut
et obscura eum ne
æmulatus fueris
eum qui*

Noli æmulari in eo qui prosperatur
in via sua : in homine faciente in-
justitias.

iniquitatem

Desine ab ira, et derelinque furo-
rem : noli æmulari ut maligneris.

*ne æmuleris ut
nequiter facias*

Quoniam qui malignantur, exter-
minabuntur : sustinentes autem Do-
minum, ipsi hæreditabunt terram.

*nequiter agunt . .
qui vero expec-
tant Dominum
ipsi hæreditate
possidebunt*

Et adhuc pusillum, et non erit pec-
cator : et quæres locum ejus, et non
invenies.

Mansueti autem hæreditabunt ter-
ram : et delectabuntur in multitudine
pacis.

possidebunt

Observabit peccator justum : et stri-
debit super eum dentibus suis.

fremebit

Dominus autem irridebit eum : quo-
niam prospicit quod veniet dies ejus.

chickens under her wings," by sending His Son into the world to save them. To that Son the ninth and tenth verses turn, anticipating His own proclamation of Himself as the Fountain of living water, the Living Bread of Which men may eat and be satisfied, the Light of the world Which enlightens all men with its beams.

A comparison of the first and last two verses with the texts referred to in the margin, will show that this Psalm also proclaims the wickedness of Antichrist and the Lord's final victory over him.

PSALM XXXVII.

Christ speaks in and to the Church, exhorting it not to be overborne by persecution or any other trouble, but to look to the

end. Evil may prevail for a time, but at last the tares will be cut down for destruction, and the wheat gathered into the garner of God. The prevailing theme of the Psalm is that of patience, and rest in the Lord. "In your patience possess ye your souls" was the Lord's own teaching to His Church respecting the troublous times that would come upon it : and twice in the book of the Revelation it is repeated, "Here is the patience and faith of the saints." In like manner the Apostles had often written to the early Church in the same strain, as if much faith was requisite to enable it to believe that in quietness and in confidence was their strength :—"Cast not away, therefore, your confidence, which hath great recompense of reward. For ye have need of patience, that after ye have done the will of God, ye might receive the promise. For yet a little while, and He that shall

The VII. Day.
Evening
Prayer.
Rev. xii. 12.

14 The ungodly have drawn out the sword, and have bent their bow : to cast down the poor and needy, and to slay such as are of a right conversation.

Gladium evaginaverunt peccatores :
intenderunt arcum suum, intenderunt
Ut deiciant pauperem et inopem :
ut trucident rectos corde.

15 Their sword shall go through their own heart : and their bow shall be broken.

Gladius eorum intret in corda ipsorum :
et arcus eorum confringatur, confringatur

Mark x. 24.

16 A small thing that the righteous hath : is better than great riches of the ungodly.

Melius est modicum justo : super
divitias peccatorum multas.

17 For the arms of the ungodly shall be broken : and the Lord upholdeth the righteous.

Quoniam brachia peccatorum conterentur :
confirmat autem justos Dominus.

of, "ways,"
Rev. xxi. 7.

18 The Lord knoweth the days of the godly : and their inheritance shall endure for ever.

Novit Dominus dies immaculato-
rum : et hæreditas eorum in æternum
erit. vias

19 They shall not be confounded in the perilous time : and in the days of dearth they shall have enough.

Non confundentur in tempore malo :
et in diebus famis saturabuntur, quia quoniam
peccatores peribunt.

Rev. xxi. 8.

20 As for the ungodly, they shall perish, and the enemies of the Lord shall consume as the fat of lambs : yea, even as the smoke shall they consume away.

Inimici vero Domini mox ut honorificati fuerint et exaltati : deficientes,
quemadmodum fumus deficient. mox honorati et exaltati fuerint def. ut

Prov. xi. 25.

21 The ungodly borroweth, and payeth not again : but the righteous is merciful and liberal.

Mutuabitur peccator, et non solvet :
justus autem miseretur et tribuet. Mutuatur . . . et commodat

22 Such as are blessed of God shall possess the land : and they that are cursed of him shall be rooted out.

Quia benedicentes ei hæreditabunt
terram : maledicentes autem ei dis-
peribunt. Quoniam . . . sunt possidebunt . . . illum disperient

Isa. xl. 29—31.

23 The Lord ordereth a good man's going : and maketh his way acceptable to himself.

Apud Dominum gressus hominis
dirigentur : et viam ejus volet. A Domino . . . cupiet nimis

24 Though he fall, he shall not be cast away : for the Lord upholdeth him with his hand.

Cum ceciderit, non collidetur : quia
Dominus supponit manum suam. ceciderit justus non conturbabitur . . . firmat manum ejus

Matt. vi. 25—34.

25 I have been young, and now am old : and yet saw I never the righteous forsaken, nor his seed begging their bread.

Junior fui, etenim senui : et non
vidi justum derelictum, nec semen ejus
quærens panem. ejus panem

Eccles. xi. 1.

26 The righteous is ever merciful, and lendeth : and his seed is blessed.

Tota die miseretur et commodat :
et semen illius in benedictione erit.

James iv. 7, 8.

27 Flee from evil, and do the thing that is good : and dwell for evermore.

Declina a malo, et fac bonum : et
inhabita in sæculum sæculi.

come will come, and will not tarry." [Heb. x. 35—37.] The trials of the early Church were so stupendous that it did indeed require a strong faith to believe that the Lord was upholding it with His hand, and that the powers of sin would not prevail. They saw the ungodly in great power, and the followers of the Righteous One every where cast down by the most bitter persecution. But they were bidden not to fret themselves because of the power of Antichrist, for that he would soon be cut down as the grass by the sickle of God's Angel : "The devil is come down unto

you, having great wrath, because he knoweth that he hath but a short time. And when the dragon saw that he was cast into the earth, he persecuted the woman which brought forth the Man." [Rev. xii. 12, 13.] They were bidden thus to be ever taking the strain of this Psalm (which was doubtless often sung by them in Divine Service) as the guiding principle of their Christian life. Let not the seeming prosperity of God's enemies make you contrast your own condition with theirs : rest in the Lord ; watch what the end will be ; assure yourselves in your faith, and believe

The VII. Day. <i>Evening Prayer.</i>	28 For the Lord loveth the thing that is right : he forsaketh not his that be godly, but they are preserved for ever.	Quia Dominus amat iudicium et non derelinquet sanctos suos : in æternum conservabuntur. <small>Quoniam</small>
Isa. xxvi. 20, 21.	29 The unrighteous shall be punished : as for the seed of the ungodly, it shall be rooted out.	Injusti punientur : et semen impiorum peribit. <small>Injusti autem</small>
Rev. v. 10.	30 The righteous shall inherit the land : and dwell therein for ever. 31 The mouth of the righteous is exercised in wisdom : and his tongue will be talking of judgement. 32 The law of his God is in his heart : and his goings shall not slide.	Justi autem hæreditabunt terram : et inhabitabunt in sæculum sæculi super eam. <small>vero hereditate possidebunt</small> Os justi meditabitur sapientiam : et lingua ejus loquetur iudicium. Lex Dei ejus in corde ipsius : et non supplantabuntur gressus ejus.
Acts iii. 14. viii. 52.	33 The ungodly seeth the righteous : and seeketh occasion to slay him. 34 The Lord will not leave him in his hand : nor condemn him when he is judged.	Considerat peccator justum : et quærit mortificare eum. <small>perdere eum</small> Dominus autem non derelinquet eum in manibus ejus : nec damnabit eum cum judicabitur illi.
Rev. v. 10.	35 Hope thou in the Lord, and keep his way, and he shall promote thee that thou shalt possess the land : when the ungodly shall perish, thou shalt see it.	Expecta Dominum, et custodi viam ejus ; et exaltabit te, ut hæreditate capias terram : cum perierint peccatores, videbis. <small>inhabiles cum perierint</small>
Dan. iv. 10—14.	36 I myself have seen the ungodly in great power : and flourishing like a green bay-tree.	Vidi impium superexaltatum : et elevatum sicut cedros Libani.
Isa. xvii. 13, 14.	37 I went by, and lo, he was gone : I sought him, but his place could no where be found.	Et transivi, et ecce non erat : quæsi eum, et non est inventus locus ejus.
Ecclus. vii. 36.	38 Keep innocency, and take heed unto the thing that is right : for that shall bring a man peace at the last. 39 As for the transgressors, they shall perish together : and the end of the ungodly is, they shall be rooted out at the last.	Custodi innocentiam, et vide æquitatem : quoniam sunt reliquæ homini pacifico. <small>veritatem et</small> Injusti autem disperibunt simul : reliquæ impiorum interibunt. <small>peribunt</small>
Rev. xxi. 4.	40 But the salvation of the righteous cometh of the Lord : who is also their strength in the time of trouble.	Salus autem justorum a Domino : et protector eorum est in tempore tribulationis.

that Christ and the right must prevail, and that evil shall be cast down. Abide patiently in the Lord, and He shall bring it to pass.

And, as the Apostolic teaching of the suffering Church often reminded them that here they had no continuing city, but that they sought one to come, so in this Psalm there are repeated references to "the land" and "the inheritance" which is prepared for those who "tarry the Lord's leisure," and look for "a house not made with hands, eternal in the heavens," though this earthly tabernacle of the Lord should be utterly dissolved. It may be that both here and in our Lord's own words, "Blessed are the meek, for they shall inherit the earth," there is a prophecy of a world purified from sin and regenerated by fire for the future habitation of the redeemed, as it was once regenerated by water.

Although the stores of precious comfort which this Psalm

contains may thus be most strongly illustrated by reference to the trials of the Church in those days when the sufferings of Christ's natural body were continued in His body mystical, yet it is not for one age alone that its words are spoken. It is still true that we "must through much tribulation enter into" our rest; and there is still need for the faith of Christians to be stirred up, that they may look to the end both as regards the Church and their own particular lot. For how often still does it seem that the ungodly are in great prosperity; that truth, peace, and love have to take the lower place in the world, while heresy, war, and hatred have the upper hand: that the good are cast down, and the wicked built up. Then is the time to sing this Psalm with a new fervour, remembering that the Son of Man once had not where to lay His head, but now reigns King of kings and Lord of lords; that His little flock was once persecuted on all

The VII. Day. 41 And the Lord shall stand by
Evening / them, and save them : he shall deliver
Prayer. / them from the ungodly, and shall save
 Heb. v. 7. 9. / them, because they put their trust in
 him.

THE XXXVIII PSALM.

Domine, ne in furore.

The VIII. Day. **P**UT me not to rebuke, O Lord, in
Morning / thine anger : neither chasten me
Prayer. / in thy heavy displeasure.

Ash-Wed. Mat-
 tins.
 A Penitential
 Psalm.
 Gen. xlix. 23.
 Job vi. 4.
 xvi. 13.

2 For thine arrows stick fast in
 me : and thy hand presseth me sore.

3 There is no health in my flesh,
 because of thy displeasure : neither is
 there any rest in my bones, by reason
 of my sin.

Isa. liii. 6.

4 For my wickednesses are gone
 over my head : and are like a sore
 burden, too heavy for me to bear.

Isa. i. 5, 6.
 Job vii. 4-6.

5 My wounds stink, and are cor-
 rupt : through my foolishness.

6 I am brought into so great trou-
 ble and misery : that I go mourning
 all the day long.

7 For my loins are filled with a
 sore disease : and there is no whole
 part in my body.

Job x. 1, 2.

8 I am feeble, and sore smitten : I
 have roared for the very disquietness
 of my heart.

Heb. v. 7.

9 Lord, thou knowest all my desire :
 and my groaning is not hid from thee.

10 My heart panteth, my strength
 hath failed me : and the sight of mine
 eyes is gone from me.

Luke xxiii. 49.
 Job xvi. 20.
 Heb. ii. 16.

11 My lovers and my neighbours
 did stand looking upon my trouble :
 and my kinsmen stood afar off.

Et adjuvabit eos Dominus, et libe-
 rabit eos : et eruet eos a peccatoribus,
 et salvabit eos, quia speraverunt in eo.

*eripiet . . . et saltem
 faciet . . . quo
 niam . . . in eum*

PSALMUS XXXVII.

DOMINE, ne in furore tuo arguas
 me : neque in ira tua corripias
 me.

Mond. Mattins.
 Good Friday,
 2nd Noct.
*in ira . . . neque
 in furore*

Quoniam sagittæ tuæ infixæ sunt
 mihi : et confirmasti super me manum
 tuam.

Non est sanitas in carne mea a facie
 iræ tuæ : non est pax ossibus meis a
 facie peccatorum meorum.

vultu

Quoniam iniquitates meæ super-
 gressæ sunt caput meum : et sicut
 onus grave gravatæ sunt super me.

*superposuerunt
 caput*

Putruerunt et corruptæ sunt cicat-
 rices meæ : a facie insipientiæ meæ.

*Computruerunt et
 deterioraverunt
 cicatrices*

Miser factus sum, et curvatus sum
 usque in finem : tota die contristatus
 ingrediebar.

*Miseriis afflictus
 sum et turbatus
 sum usque in*

Quoniam lumbi mei impleti sunt
 illusionibus : et non est sanitas in
 carne mea.

*anima mea con-
 plieta est*

Afflictus sum et humiliatus sum
 nimis : rugiebam a gemitu cordis mei.

*Incurbatus sum
 et . . . usque
 quaque rugie-
 bam*

Domine, ante te omne desiderium
 meum : et gemitus meus a te non est
 absconditus.

Et ante

Cor meum conturbatum est, dere-
 liquit me virtus mea : et lumen oculo-
 rum meorum et ipsum non est mecum.

*cont. est in me ut
 deseruit me for-
 titudo mea*

Amici mei et proximi mei : adver-
 sum me appropinquaverunt, et stete-
 runt.

adpropinquaverunt

sides, yet now extends through all kingdoms of the world. "They
 that patiently abide the Lord, those shall inherit the land."

PSALM XXXVIII.

Lest we should fear to consider these words of deep penitence
 as those of our Lord, the eleventh, thirteenth, and fourteenth
 verses are specially pointed towards the circumstances which
 attended His last hours, when "all the disciples forsook Him and
 fled," and when the words of the prophecy were literally fulfilled
 concerning the "Lamb of God;" "He was oppressed, and He
 was afflicted; yet He opened not His mouth. He is brought as
 a lamb to the slaughter, and as a sheep before her shearers is
 dumb, so He openeth not His mouth;" "Then Herod ques-
 tioned with Him in many words, but He answered nothing."
 "And when He was accused of the chief priests and elders, He
 answered nothing." The Psalm throughout may be profitably
 compared with Isaiah liii. and Job xvi. and xvii.; where in one

case we see the most distinct prophecy of our Lord's vicarial work
 of penitential suffering, and in the other a personal type of Him
 in His affliction. "Ye have heard of the patience of Job, and have
 seen the end of the Lord." [James v. 11.]

It is not unlikely that when David wrote this Psalm he was
 suffering some bodily affliction such as Job had suffered, and that
 all from the third to the seventh verse had a literal meaning when
 uttered by him. When these verses are taken of our Lord, they
 must be taken of the torture which His holy Body underwent
 from the agony of the wounds caused by the nails in His hands
 and feet, and the spear thrust into His side, and the racking pain
 of hanging from the Cross. Our Lord speaks them also, mysti-
 cally, of His mystical Body, of which He was bearing the sins;
 sins, the effects of which upon human nature are described in the
 words of the prophet, "The whole head is sick, and the whole heart
 faint. From the sole of the foot even unto the head there is no
 soundness in it, but wounds, and bruises, and putrifying sores ;

The VIII. Day. Morning Prayer. 12 They also that sought after my life laid snares for me : and they that went about to do me evil, talked of wickedness, and imagined deceit all the day long.

Isa. liii. 7. Luke xxiii. 9. 13 As for me, I was like a deaf man, and heard not : and as one that is dumb, who doth not open his mouth.

Matt. xxvi. 63. xxvii. 12. 1 Pet. ii. 22. 14 I became even as a man that heareth not : and in whose mouth are no reproofs:

Job xiii. 15. 15 For in thee, O Lord, have I put my trust : thou shalt answer for me, O Lord my God.

16 I have required that they, even mine enemies, should not triumph over me : for when my foot slipped, they rejoiced greatly against me.

17 And I, truly, am set in the plague : and my heaviness is ever in my sight.

18 For I will confess my wickedness : and be sorry for my sin.

19 But mine enemies live, and are mighty : and they that hate me wrongfully are many in number.

Dan. vi. 5. 20 They also that reward evil for good are against me : because I follow the thing that good is.

21 Forsake me not, O Lord my God : be not thou far from me.

22 Haste thee to help me : O Lord God of my salvation.

THE XXXIX PSALM.

Dixi, custodiam.

Burial of the dead. I SAID, I will take heed to my ways : that I offend not in my tongue.

Et qui juxta me erant de longe steterunt: et vim faciebant qui quærebant animam meam. Et proximi mei a longe

Et qui inquirebant mala mihi locuti sunt vanitates : et dolos tota die meditabantur.

Ego autem tanquam surdus non audiveram : et sicut mutus non aperiens os suum. velut aperiet

Et factus sum sicut homo non audiens : et non habens in ore suo redargutiones.

Quoniam in te, Domine, speravi : tu exaudies me, Domine Deus meus.

Quia dixi, Nequando supergaudeant mihi inimici mei : et dum commoventur pedes mei, super me magna locuti sunt.

Quoniam ego in flagella paratus sum : et dolor meus in conspectu meo semper.

Quoniam iniquitatem meam annuntiabo : et cogitabo pro peccato meo.

Inimici autem mei vivunt et confirmati sunt super me : et multiplicati sunt qui oderunt me inique.

Qui retribuunt mala pro bonis detrahebant mihi : quoniam sequebar bonitatem.

Ne derelinquas me Domine Deus meus : ne discesseris a me.

Intende in adjutorium meum : Domine Deus salutis meæ.

PSALMUS XXXVIII.

DIXI, Custodiam vias meas : ut non delinquam in lingua mea. Tuesd. Mattins.

they have not been closed, neither bound up, neither mollified with ointment." [Isa. i. 5, 6.] The words of the fifth verse in the Vulgate seem especially to connect the latter words of the prophet with the Psalm, for they seem to speak of wounds partly healed, but again reopened, such wounds as the moral cicatrices of human nature had been subjected to from the time of its first deadly wound in the Fall.

In such a spiritual sense, also, is this penitential Psalm to be used by individual Christians. Remembering how hateful all sin is in the sight of God, how it has marred the beauty of His handiwork, and how totally incurable are the wounds it causes except by the remedy of Christ's Incarnation and sufferings, none need consider the expressions which are used too strong for ordinary penitents. She who so clearly saw her sin ever before her in the days of our Lord's earthly life, and who laid it all upon Him as she bathed His feet with her tears, was honoured by our Lord's words, "She loved much." So the greater the love of

God, the greater will be the hatred of sin, the more clear will be the view of its sinfulness, the more freely will the lips confess it, and the more deeply the heart be sorry for it. While, therefore, this Psalm reveals to us some of the feelings by which our Redeemer was moved when He bore our sins in His own Body on the tree, it furnishes also a Divine strain of penitence which His members may take on their lips from age to age as following His example.

PSALM XXXIX.

When our Redeemer said, "If it be possible, let this cup pass from Me," He was praying in the spirit and almost in the words of David, "Take Thy plague away from me;" and when David sang, "When Thou with rebukes dost chasten man for sin, Thou makest his beauty to consume away," he was prophesying of Him "Whose visage was marred more than any man," and Who when we should see Him should "have no beauty in Him that

The VIII. Day.
Morning
Prayer.
James iii. 3-10.

2 I will keep my mouth as it were with a bridle : while the ungodly is in my sight.

3 I held my tongue, and spake nothing : I kept silence, yea, even from good words ; but it was pain and grief to me.

Jer. xx. 9.

4 My heart was hot within me, and while I was thus musing the fire kindled : and at the last I spake with my tongue.

Job vi. 11.

5 Lord, let me know mine end, and the number of my days : that I may be certified how long I have to live.

Job xiv. 1.
xvi. 22.
Eccl. i. 2.

6 Behold, thou hast made my days as it were a span long : and mine age is even as nothing in respect of thee, and verily every man living is altogether vanity.

Mark x. 23.

7 For man walketh in a vain shadow, and disquieteth himself in vain : he heapeth up riches, and cannot tell who shall gather them.

8 And now, Lord, what is my hope : truly my hope is even in thee.

9 Deliver me from all mine offences : and make me not a rebuke unto the foolish.

Isa. liii. 7.
John xix. 10, 11.

10 I became dumb, and opened not my mouth : for it was thy doing.

Luke xxii. 42.

11 Take thy plague away from me : I am even consumed by the means of thy heavy hand.

Isa. lii. 14.
liii. 1.
Job xiii. 23.

12 When thou with rebukes dost chasten man for sin, thou makest his beauty to consume away, like as it were a moth fretting a garment : every man therefore is but vanity.

13 Hear my prayer, O Lord, and with thine ears consider my calling : hold not thy peace at my tears.

Posui ori meo custodiam : cum consistit
sisteret peccator adversum me.

Obmutui, et humiliatus sum, et silui a bonis : et dolor meus renovatus est.

Concaluit cor meum intra me : et in meditatione mea exardescet ignis.

Locutus sum in lingua mea : Notum fac mihi, Domine, finem meum ;

Et numerum dierum meorum, quis est : ut sciam quid desit mihi.

Ecce mensurabiles posuisti dies
meos : et substantia mea tanquam
nihilum ante te.

Veruntamen universa vanitas : omnis homo vivens.

Veruntamen in imagine pertransit
homo : sed et frustra conturbatur.

Thesaurizat : et ignorat cui congregabit ea.

Et nunc quæ est expectatio mea ? nonne Dominus ? et substantia mea apud te est.

Ab omnibus iniquitatibus meis erue
me : opprobrium insipienti dedisti me.

Obmutui, et non aperui os meum, quoniam tu fecisti : amove a me plagas tuas.

A fortitudine manus tuæ ego defeci : enim manus
in increpationibus, propter iniquitatem,
corripuisti hominem.

Et tabescere fecisti sicut araneam animam ejus : veruntamen vane conturbatur omnis homo.

Exaudi orationem meam, Domine, et deprecationem meam : auribus percipe lachrymas meas.

we should desire Him." This Psalm may, therefore, be reverently considered as the words of Christ speaking for His members, and declaring in His own person the sorrows which death had wrought and would continue to work in the world. "We see Jesus, Who was made a little lower than the angels for the suffering of death, crowned with glory and honour : that He by the grace of God should taste death for every man." [Heb. ii. 9.] That He might become in all things like unto His brethren, He also became a stranger and a sojourner, and ended His pilgrimage by tasting death, that death might be vanquished.

In this Psalm, especially when used in the Burial Office, we may hear Christ saying to all those who desire a place in His kingdom, "Can ye drink of the cup that I drink of, and be baptized with the baptism that I am baptized with ?" Through death He triumphed over death and entered into His glory, being

made perfect through suffering : and by the grave and gate of death His people must pass that they may attain a joyful resurrection. Resignation, prayer, trust, and hope are, therefore, the four notes of the chord which sounds throughout this mournful hymn. "What is your life ? It is even a vapour, that appeareth for a little time, and then vanisheth away." [James iv. 14.] Yet, "I know that my Redeemer liveth, Who is the Resurrection and the Life, and though He slay me, yet will I trust in Him. We know that if our earthly house of this tabernacle were dissolved, we have a building of God, an house not made with hands, eternal in the heavens : " and we may therefore say, "O death, where is thy sting ? O grave, where is thy victory ?" for "if we believe that Jesus died, and rose again, even so them also that sleep in Jesus will God bring with Him." Thus the light of the glorious Gospel has transfigured the mournful words of the Old Testa-

The VIII. Day.

Morning

Prayer.

Lev. xxv. 23.

Heb. xi. 13.

Job x. 20, 21.

Luke xxii. 43.

Matt. xxvi. 46.

14 For I am a stranger with thee,
and a sojourner ; as all my fathers
were.

15 O spare me a little, that I may
recover my strength ; before I go
hence, and be no more seen.

THE XL PSALM.

*Expectans expectavi.*Good Friday
Mattins.

I WAITED patiently for the Lord ;
and he inclined unto me, and heard
my calling.

John xix. 30.
Luke xiii. 33.

2 He brought me also out of the
horrible pit, out of the mire and clay ;
and set my feet upon the rock, and
ordered my goings.

Luke xxiii. 46.

3 And he hath put a new song in
my mouth : even a thanksgiving unto
our God.

Luke xxiii. 47.

4 Many shall see it and fear ; and
shall put their trust in the Lord.

Rev. xxii. 14.

5 Blessed is the man that hath set
his hope in the Lord ; and turned not
unto the proud, and to such as go
about with lies.

Rev. xv. 3.
Rom. xi. 33.

6 O Lord my God, great are the
wondrous works which thou hast done,
like as be also thy thoughts which are
to us-ward ; and yet there is no man
that ordereth them unto thee.

7 If I should declare them and
speak of them ; they should be more
than I am able to express.

Heb. x. 5-7.
John i. 14.
Exod. xxi. 6.
Rom. xi. 1.
Isa. l. 5.

8 Sacrifice and meat-offering thou
wouldest not ; but mine ears hast
thou opened.

Heb. x. 19, 20.
xii. 24.

9 Burnt-offerings and sacrifice for
sin hast thou not required ; then said
I, Lo, I come,

John iv. 34.
v. 30.
Luke xxii. 42.

10 In the volume of the book it is
written of me, that I should fulfil thy
will, O my God ; I am content to do
it ; yea, thy law is within my heart.

Ne sileas, quoniam advena ego sum a me quoniam
incola in terra
et peregr.
apud te : et peregrinus, sicut omnes
patres mei.

Remitte mihi, ut refrigerer prius-
quam abeam : et amplius non ero.

PSALMUS XXXIX.

EXSPECTANS expectavi Domi-
num : et intendit mihi.

Tuesd. Mattins,
Good Friday,
2nd Noct.
Mattins of the
departed.
et respexit me
deprecationem
meam

Et exaudivit preces meas : et eduxit
me de lacu miseræ, et de luto fæcis.

Et statuit super petram pedes meos :
et direxit gressus meos.

Et immisit in os meum canticum
novum : carmen Deo nostro.

hymnum Deo

Videbunt multi et timebunt : et
sperabunt in Domino.

Beatus vir cujus est nomen Domini
spes ejus : et non respexit in vanitates
et insanias falsas.

Multa fecisti tu, Domine Deus meus,
mirabilia tua : et cogitationibus tuis
non est qui similis sit tibi.

Annuntiavi et locutus sum : mul-
tiplicati sunt super numerum.

Sacrificium et oblationem noluisti :
aures autem perfecisti mihi.

corpus autem .

Holocaustum et pro peccato non
postulasti : tunc dixi ; Ecce venio.

*Holocausta etiam
pro delicto*

In capite libri scriptum est de me,
ut facerem voluntatem tuam ; Deus
meus, volui : et legem tuam in medio
cordis mei.

ment saint, and developed out of them a new meaning to those
who sorrow not as men without hope.

PSALM XL.

The words of St. Paul in the Epistle to the Hebrews, and the
custom of the Church in adopting this Psalm for Good Friday,
identify it as a hymn of Christ : and with this key to the
meaning of it there is no difficulty in tracing out that He speaks,
first, as One offering up Himself as a personal Sacrifice of atone-
ment for sin ; and, secondly, as the Head of the Mystical Body
which He is pleased to associate in intimate oneness with Him-
self. A Body hast Thou prepared Me that I may offer it as the

One acceptable Sacrifice : a Body hast Thou prepared Me that
the mystery of my Incarnation may be continued in the mystery
of My Church¹.

As a Psalm applicable to the day of Christ's Passion, it must
be considered in the light of a solemn, and even awful, thanks-
giving for His death as the source of the world's new life. The

¹ "A body hast Thou prepared me," is quoted by St. Paul from the
Septuagint, not from the Hebrew. It will be observed above that the
ancient Vulgate, the "Vetus Itala," quoted in the margin, has the same
reading ; while the more modern Vulgate of St. Jerome's later revision has
a reading very similar to that of the English. The piercing of the ears was
a sign of servitude. See Exod. xxi. 6.

The VIII. Day. Morning Prayer. John xix. 20. Acts ii. 5. Luke ii. 32. 11 I have declared thy righteousness in the great congregation : lo, I will not refrain my lips, O Lord, and that thou knowest.

John xvii. 12, 14. 12 I have not hid thy righteousness within my heart : my talk hath been of thy truth, and of thy salvation.

Eph. ii. 11-18. 13 I have not kept back thy loving mercy and truth : from the great congregation.

14 Withdraw not thou thy mercy from me, O Lord : let thy loving-kindness and thy truth alway preserve me.

15 For innumerable troubles are come about me, my sins have taken such hold upon me that I am not able to look up : yea, they are more in number than the hairs of my head, and my heart hath failed me.

16 O Lord, let it be thy pleasure to deliver me : make haste, O Lord, to help me.

17 Let them be ashamed, and confounded together, that seek after my soul to destroy it : let them be driven backward, and put to rebuke, that wish me evil.

18 Let them be desolate, and rewarded with shame : that say unto me, Fie upon thee, fie upon thee.

19 Let all those that seek thee be joyful and glad in thee : and let such as love thy salvation say alway, The Lord be praised.

20 As for me, I am poor and needy : but the Lord careth for me.

Rev. xxii. 20. 21 Thou art my helper and redeemer : make no long tarrying, O my God.

Annuntiavi justitiam tuam in ecclesia magna : ecce labia mea non prohibebo ; Domine, tu scisti. Bene nuntiavi cognovisti

Justitiam tuam non abscondi in corde meo : veritatem tuam et salutare tuum dixi.

Non abscondi misericordiam tuam et veritatem tuam : a concilio multo. celavi. a synagoga nulla

Tu autem, Domine, ne longe facias miserationes tuas a me : misericordia tua et veritas tua semper susceperunt me. miseri cordias tuas

Quoniam circumdederunt me mala quorum non est numerus : comprehenderunt me iniquitates meae, et non potui ut viderem.

Multiplicatae sunt super capillos capitis mei : et cor meum dereliquit me.

Complaceat tibi, Domine, ut eruas me : Domine, ad adjuvandum me respice. eripias in auxilium meum

Confundantur et revertantur simul qui quaerunt animam meam : ut auferant eam.

Convertantur retrorsum et revertantur : qui volunt mihi mala. Convertantur . . . et erubescant qui cogitant

Ferant confestim confusionem suam : qui dicunt mihi, Euge, euge.

Exultent et laetentur super te omnes quaerentes te : et dicant semper, Magnificetur Dominus, qui diligunt salutare tuum. laetentur qui quaerunt te Domine

Ego autem mendicus sum et pauper : Dominus sollicitus est mei. egenus et curas habet mei

Adjutor meus, et protector meus tu es : Deus meus, ne tardaveris. et liberator

agony and the darkness are past : and, even from the Cross, He Who took upon Him the form of a Servant and wore the badge of the bondage of sin, can behold His triumph in all future ages. "He shall see of the travail of His soul, and shall be satisfied. By His knowledge shall My Righteous Servant justify many : for He shall bear their iniquities." [Isa. liii. 11.] Thus it is a song of Good Friday sorrows sung in the knowledge that Easter is to follow : and the tone of it is like those pictures of the Crucifixion in which our Lord's incarnate Body is suspended free upon the Cross, surrounded by the glorious rays of that Divine Nature which made it impossible for His soul to be left in hell, or for His flesh to see corruption. [Acts ii. 31.]

The words "I waited patiently," are suggestive of several interpretations. (1) Of our Lord's waiting, until the fulness of the time should come when that blessed work of Redemption should be wrought which He had purposed from the time of the Fall itself. (2) Of that patient waiting for the time of the appointed

Sacrifice which is indicated by the declaration on several occasions that His hour was not yet come. (3) Of that patience which the prophet foresaw when he declared that as a sheep before her shearers is dumb, so He openeth not His mouth, and that He gave His back to the smiters, and His cheeks to them that plucked off the hair. (4) Of Christ speaking in the name of His people who are waiting the Lord's good time in the Church on earth and in the Church of Paradise ; some in afflictions,—like their Master and Head,—many full of ardent longing to be with Him, all in the hope of that blessedness which He holds forth in the Church Triumphant. "I waited patiently for the Lord. . . . Make no long tarrying, O my God." With a versicle and response breathing the same tone the Holy Bible ends :

Ÿ. Surely I come quickly : Amen.

R̄. Even so, come, Lord Jesus.

In such a tone the suffering Saviour commended His soul on the first Good Friday, saying, "Father, into Thy hands I commend

THE XLI PSALM.

Beatus qui intelligit.

The VIII. Day.
Evening
Prayer.

1 Cor. xi. 29.

Luke xxiii. 25.

Hos. xiv. 4.

Matt. xxvi. 48.

Acts i. 25.

al. "lieth."

John xiii. 18.

BLESSED is he that considereth the poor and needy : the Lord shall deliver him in the time of trouble.

2 The Lord preserve him, and keep him alive, that he may be blessed upon earth : and deliver not thou him into the will of his enemies.

3 The Lord comfort him when he lieth sick upon his bed : make thou all his bed in his sickness.

4 I said, Lord, be merciful unto me : heal my soul, for I have sinned against thee.

5 Mine enemies speak evil of me : When shall he die, and his name perish ?

6 And if he come to see me, he speaketh vanity : and his heart conceiveth falsehood within himself, and when he cometh forth he telleth it.

7 All mine enemies whisper together against me : even against me do they imagine this evil.

8 Let the sentence of guiltiness proceed against him : and now that he dieth, let him rise up no more.

9 Yea, even mine own familiar friend, whom I trusted : who did also eat of my bread, hath laid great wait for me.

10 But be thou merciful unto me, O Lord : raise thou me up again, and I shall reward them.

11 By this I know thou favourest me : that mine enemy doth not triumph against me.

12 And when I am in my health, thou upholdest me : and shalt set me before thy face for ever.

13 Blessed be the Lord God of Israel : world without end. Amen.

PSALMUS XL.

BEATUS qui intelligit super egenum et pauperem : in die mala liberabit eum Dominus.

Dominus conservet eum, et vivificet eum, et beatum faciat eum in terra : et non tradat eum in animam inimicorum ejus.

Dominus opem ferat illi super lectum doloris ejus : universum stratum ejus versasti in infirmitate ejus.

Ego dixi, Domine, miserere mei : sana animam meam, quia peccavi tibi.

Inimici mei dixerunt mala mihi : Quando morietur et peribit nomen ejus ?

Et si ingrediebatur ut videret, vana loquebatur : cor ejus congregavit iniquitatem sibi.

Egrediebatur foras : et loquebatur in idipsum.

Adversum me susurrabant omnes inimici mei : adversum me cogitabant mala mihi.

Verbum iniquum constituerunt adversum me : nunquid qui dormit, non adjiciet ut resurgat ?

Etenim homo pacis meæ, in quo speravi, qui edebat panes meos : magnificavit super me supplantationem.

Tu autem, Domine, miserere mei, et resuscita me : et retribuam eis.

In hoc cognovi quoniam voluisti me : quoniam non gaudebit inimicus meus super me.

Me autem propter innocentiam suscepisti : et confirmasti me in conspectu tuo in æternum.

Benedictus Dominus Deus Israël : a sæculo, et in sæculum ; Fiat, fiat.

Tuesd. Mattins.
Mattins of the departed.

et mundet in terra
animam ejus et
non tradat eum
in manus inimi-
ci ejus

cor eorum congregaverunt

loquebatur simul
in unum susurrabant

mandaverunt

amplavit

et usque in

My spirit." and in such a tone also may His mystical Body, corporate and in its several members, be ever patiently waiting for the Lord, and working in humble obedience during the time of waiting.

PSALM XLI.

There is enough analogy between this and the first Psalm to lead to the conclusion that it was intended for the position it now occupies as the last Psalm of the first book ; the end of which book is marked by the Doxology. As the first is a meditative hymn on the blessedness of the guileless Man, so this is one upon the mystery of His poverty Who became poor that He

might make many rich. Our Lord quoted it as applying to Himself in John xiii. 18, declaring that the ninth verse of the Psalm was fulfilled by His Betrayal. The fifth and four following verses relate therefore to the betrayer, his sentence and his punishment, and "now that he dieth," [or "lieth,"] "let him rise up no more," may be compared with the mysterious words of St. Peter, that Judas had gone "to his own place."

This Psalm is to be viewed in two aspects. (1) It sets forth the blessedness of "considering,"—or meditating upon with understanding,—the Person of the Redeemer ; an aspect which may remind us of St. Paul's expression as to "discerning" or "considering" the Lord's Body in the Holy Eucharist. [1 Cor.

THE XLII PSALM.

Quemadmodum.

The VIII. Day.
Evening
Prayer.
Joel i. 20.

LIKE as the hart desireth the water-brooks : so longeth my soul after thee, O God.

John xix. 28.
iv. 14. vii. 37.
Rev. xxii. 4. 17.
20. vii. 17.
xxi. 4.

2 My soul is athirst for God, yea, even for the living God : when shall I come to appear before the presence of God?

Lament. i. 16. 2.

3 My tears have been my meat day and night : while they daily say unto me, Where is now thy God?

Job xxx. 16.
John xii. 27. 12.

4 Now when I think thereupon, I pour out my heart by my self : for I went with the multitude, and brought them forth into the house of God ;

Luke xix. 38. 47.

5 In the voice of praise and thanksgiving : among such as keep holy-day.

6 Why art thou so full of heaviness, O my soul : and why art thou disquieted within me?

al. "so dis-
quieted."
John xii. 28.
2 Cor. iv. 8.

7 Put thy trust in God : for I will yet give him thanks for the help of his countenance.

8 My God, my soul is vexed within me : therefore will I remember thee concerning the land of Jordan, and the little hill of Hermon.

Mark xv. 34.

9 One deep calleth another, because of the noise of the water-pipes : all thy waves and storms are gone over me.

Job xxxv. 10.

10 The Lord hath granted his lovingkindness in the day-time : and in the night-season did I sing of him, and made my prayer unto the God of my life.

PSALMUS XLI.

QUEMADMODUM desiderat cervus ad fontes aquarum : ita desiderat anima mea ad te Deus.

Tuesd. Mattins.
Matt. of the de-
parted.

Sitivit anima mea ad Deum fontem vivum : quando veniam, et apparebo ante faciem Dei?

ad Deum vivum

Fuerunt mihi lachrymæ meæ panes die ac nocte : dum dicitur mihi quotidie, Ubi est Deus tuus?

Hæc recordatus sum, et effudi in me animam meam : quoniam transibo in locum tabernaculi admirabilis, usque ad domum Dei.

ingrediar

In voce exultationis et confessionis : sonus epulantis.

Quare tristis es anima mea? et quare conturbas me?

Spera in Deo, quoniam adhuc confitebor illi : salutare vultus mei et Deus meus.

quoniam confitebor

Ad meipsum anima mea conturbata est : propterea memor ero tui de terra Jordanis, et Hermonii a monte modico.

A meipso . . . turbata
tui Domine

Abyssus abyssum invocat : in voce cataractarum tuarum.

Omnia excelsa tua et fluctus tui : super me transierunt.

In die mandavit Dominus misericordiam suam : et nocte canticum ejus.

nocte declaravit

Apud me oratio Deo vitæ meæ : dicam Deo, Susceptor meus es :

xi. 29.] As "many are weak and sickly, and many sleep" [Ibid.] through *not* considering the Poor and Needy, so will the Lord deliver from trouble, preserve alive, strengthen and comfort those who there do discern Him. (2) The second aspect under which the Psalm is to be viewed shows the Son of God Himself considering poor and needy human nature, and coming down from Heaven to become as one of us. In His time of trouble the Lord delivered Him, and was merciful to Him when He became as the One Sinner in the place of all sinners.

It will have been observed that all the forty-one Psalms which compose the first book point unswervingly to our Blessed Lord. They were a gift to the Church of Israel, that its faith might look forward in hope : they are a gift to the Christian Church, that her faith may be intelligently fixed upon her Redeemer, and behold throughout the written word—"in the volume of the book"—the story of the personal WORD'S Incarnation and redeeming work.

THE SECOND BOOK.

PSALM XLII.

The Second Book of the Psalms opens with one in which Christ is again heard speaking. He speaks in His own Person as longing for the time of ascending to His Father, in the person of His mystical Body as longing for the time when her earthly pilgrimage will be ended, and her militant humiliation transfigured into triumphant glory. It was formerly used in the Burial Office of the Church of England [see p. 295] : and has a place in the Primitive Liturgy of St. Mark, both applications of it expressing the earnest longing of the Church and the devout soul for the Divine Presence : "My soul is athirst for God in His Eucharistic Mystery : My soul is athirst for Him in the rest or Paradise."

In their fulness the aspirations of this Psalm can only be assigned to Christ Himself. Job typically anticipated the suf-

The VIII. Day. 11 I will say unto the God of my
Evening
Prayer. strength, Why hast thou forgotten
 Job x. 1, 2. me : why go I thus heavily, while the
 enemy oppresseth me ?

Job xxx. 17. 12 My bones are smitten asunder
 as with a sword : while mine enemies
 that trouble me cast me in the teeth ;

Job ii. 9. xix. 3. 13 Namely, while they say daily
 Luke xxiii. 35. unto me : Where is now thy God ?
 Matt. xxvii. 43.

14 Why art thou so vexed, O my
 soul : and why art thou so disquieted
 within me ?

Job xxxi. 3-6. 15 O put thy trust in God : for I
 will yet thank him, which is the help
 of my countenance, and my God.

THE XLIII PSALM.

Judica me, Deus.

GIVE sentence with me, O God,
 and defend my cause against the
 ungodly people : O deliver me from
 the deceitful and wicked man.

2 For thou art the God of my
 strength, why hast thou put me from
 thee : and why go I so heavily, while
 the enemy oppresseth me ?

3 O send out thy light and thy
 truth, that they may lead me : and
 bring me unto thy holy hill, and to
 thy dwelling.

Isa. lx. 1.
 John i. 4.
 xiv. 6.
 Rev. xxi. 23.

4 And that I may go unto the altar
 of God, even unto the God of my joy
 and gladness : and upon the harp will
 I give thanks unto thee, O God, my
 God.

Quare oblitus es mei? quare con- et quare meroppu-
 tristatus incedo, dum affligit me ini- listi et quare
 micus? tristis incedo
dum aff.

Dum confringuntur ossa mea, ex- omnia ossa
 probraverunt mihi: qui tribulant me qui tribulant me
 inimici mei. dum dicitur
mih

Dum dicunt mihi per singulos dies :
 Ubi est Deus tuus ?

Quare tristis es anima mea? et
 quare conturbas me ?

Spera in Deo, quoniam adhuc con- quoniam confite-
 fitebor illi: salutare vultus mei, et bor
 Deus meus.

PSALMUS XLII.

JUDICA me, Deus, et discerne cau- Tuesday Lauds.
 sam meam de gente non sancta :
 ab homine iniquo et doloso erue me. eripe

Quia tu es Deus fortitudo mea : Deus meus et
 quare me repulisti, et quare tristis fortitudo
 incedo, dum affligit me inimicus ?

Emitte lucem tuam et veritatem
 tuam : ipsa me deduxerunt et ad-
 duxerunt in montem sanctum tuum,
 et in tabernacula tua.

Et introibo ad altare Dei : ad Deum
 qui lætificat juventutem meam.

ferings of the holy One to a certain extent, so that he could say, "And now my soul is poured out upon me, the days of affliction have taken hold upon me," but it was to the soul of the "Man of sorrows" alone that the whole force of such words as those of this Psalm could belong: of Him only that it could be said one abyss proclaimed to another that all the waves and storms of Divine anger with sin had overwhelmed Him. We may, therefore, see in the touching expressions of this beautiful hymn the highest and most perfect form of resignation to the will of God under the most extreme depression of sorrow and suffering: words which open out to us the mind of Christ, showing how the truly faithful soul will trust in God as a loving Father, and long for His presence, even when bowing down under the weight of trial: "longing to be with Christ, which is far better," yet desiring, above all, to fulfil His will. It is a Psalm which must have had especial force in the Divine Service of the early Church, when persecutions surrounded it on every side, and the echoes from one overwhelming cataract of heathen fury overtook the rush of another. Such intense longings for a better life and the peace of Paradise belong to such times rather than to those of untroubled ages: and when the Antichristian persecutions of the latter days have come upon the Church, the meaning of this hymn will again be felt in its fulness as it may have been felt by those

who had to endure the Antichrists of the first age. Yet the spirit of the Psalm enters into all longings for the Presence of Christ: and those who fully realize the work of sin will be able to enter into it to a great extent in connexion with the blessedness of that Presence in the Eucharistic Mystery.

PSALM XLIII.

This is plainly a continuation of the preceding Psalm, (though not a portion of it,) the ideas of it being exactly analogous, and the burden, from which the whole derives so mournful and passion-like a character, repeated; yet a distinctive character is also given to this concluding portion of the threefold hymn, which makes it a song anticipative of Resurrection joy. As the words of Christ are, "Thou wilt not leave My soul in hell . . . Thou wilt show Me the path of life;" so they are, "Send out Thy light . . . bring Me unto Thy holy hill." And while we hear Christ longing for the light of the Resurrection, and the Altar where the Lamb, as it had been slain, was to take His kingdom to Himself, so we also hear the voice of His Church asking God to send forth to her the Light of the world, in the Person of Christ, to lead her through this life to glory everlasting, and by the earthly to the heavenly Altar. The third verse looks plainly to Him Who is the Way, the Truth, the Life, and the Light of the City of God; and

The VIII. Day. *Evening Prayer.* 5 Why art thou so heavy, O my soul : and why art thou so disquieted within me ?

6 O put thy trust in God : for I will yet give him thanks, which is the help of my countenance, and my God.

THE XLIV PSALM.

Deus, auribus.

The IX. Day. *Morning Prayer. Litany.* **W**E have heard with our ears, O God, our fathers have told us : what thou hast done in their time of old ;

Deut. vii. 1. 2 How thou hast driven out the heathen with thy hand, and planted them in : how thou hast destroyed the nations, and cast them out.

Deut. viii. 17, 18. 3 For they gat not the land in possession through their own sword : neither was it their own arm that helped them ;

Exod. xxxiii. 14. Isa. lxiii. 9. Deut. iv. 37. 4 But thy right hand, and thine arm, and the light of thy countenance : because thou hadst a favour unto them.

5 Thou art my King, O God : send help unto Jacob.

Deut. xxxiii. 17. Isa. lxiii. 8. Rev. xix. 15. 6 Through thee will we overthrow our enemies : and in thy Name will we tread them under that rise up against us.

7 For I will not trust in my bow : it is not my sword that shall help me ;

8 But it is thou that savest us from our enemies : and puttest them to confusion that hate us.

9 We make our boast of God all day long : and will praise thy Name for ever.

10 But now thou art far off, and puttest us to confusion : and goest not forth with our armies.

2 Cor. iv. 7-11. 11 Thou makest us to turn our backs upon our enemies : so that they which hate us spoil our goods.

Confitebor tibi in cithara, Deus, Deus meus : quare tristis es anima mea, et quare conturbas me ?

Spera in Deo, quoniam adhuc confitebor illi : salutare vultus mei et Deus meus. quoniam confitebor

PSALMUS XLIII.

DEUS, auribus nostris audivimus : Tuesd. Mattins. patres nostri annuntiaverunt nobis,

Opus quod operatus es in diebus eorum : et in diebus antiquis.

Manus tua gentes disperdidit et plantasti eos : afflixisti populos et expulisti eos.

Nec enim in gladio suo possederunt terram : et brachium eorum non salvavit eos. possidebunt salvabit

Sed dextera tua, et brachium tuum, et illuminatio vultus tui : quoniam complacuisti in eis.

Tu es ipse Rex meus et Deus meus : qui mandas salutes Jacob.

In te inimicos nostros ventilabimus cornu : et in nomine tuo spernemus insurgentes in nobis. ventilavimus et in nom.

Non enim in arcu meo sperabo : et gladius meus non salvabit me.

Salvast enim nos de affligentibus nos : et odientes nos confudisti.

In Deo laudabimur tota die : et in nomine tuo confitebimur in sæculum.

Nunc autem repulisti et confudisti nos : et non egredieris, Deus, in virtutibus nostris.

Avertisti nos retrorsum post inimicos nostros : et qui oderunt nos diripiebant sibi. præ inimicis

the fourth verse as plainly to the Eucharistic thanksgiving of the Christian dispensation.

PSALM XLIV.

For periods of great trouble, such as the time when the Philistines came up with their champion against the army of Saul, or when Sennacherib against Hezekiah, or when the nation was broken to pieces by the tyranny of Antiochus Epiphanes, this

Psalm was penned as a national pleading with God for His own people in their affliction ; and, so prophesying, the writer unconsciously gave words to the future Church, which might in all ages be lifted up to God as a prayer for deliverance.

It must be understood that the tone of this Psalm is by no means one of expostulation with God, as if it were to be said to Him, Why hast Thou done this ? It is, on the contrary, a declaration of perfect trust in Him, like that uttered by Job when he

The IX. Day.
*Morning
Prayer.*
Matt. xxiv. 9.

12 Thou lettest us be eaten up like sheep : and hast scattered us among the heathen.

Isa. lii. 3.

13 Thou sellest thy people for nought : and takest no money for them.

14 Thou makest us to be rebuked of our neighbours : to be laughed to scorn, and had in derision of them that are round about us.

Job xvii. 6.

15 Thou makest us to be a by-word among the heathen : and that the people shake their heads at us.

16 My confusion is daily before me : and the shame of my face hath covered me ;

Isa. xxxvi. 15. 20.

17 For the voice of the slanderer and blasphemer : for the enemy and avenger.

2 Cor. iv. 16.

18 And though all this be come upon us, yet do we not forget thee : nor behave ourselves frowardly in thy covenant.

19 Our heart is not turned back : neither our steps gone out of thy way ;

20 No, not when thou hast smitten us into the place of dragons : and covered us with the shadow of death.

21 If we have forgotten the Name of our God, and holden up our hands to any strange god : shall not God search it out ? for he knoweth the very secrets of the heart.

Rom. viii. 36.
Rev. xii. 11.

22 For thy sake also are we killed all the day long : and are counted as sheep appointed to be slain.

Isa. xxxviii. 17—
20.

23 Up, Lord, why sleepest thou : awake, and be not absent from us for ever.

24 Wherefore hidest thou thy face : and forgettest our misery and trouble ?

Rev. vi. 9.

25 For our soul is brought low, even unto the dust : our belly cleaveth unto the ground.

Rev. vi. 10.
Litany.

26 Arise, and help us : and deliver us for thy mercy's sake.

Dedisti nos tanquam oves escarum : et in gentibus dispersisti nos.

Vendidisti populum tuum sine pretio : et non fuit multitudo in commutationibus eorum.

Posuisti nos opprobrium vicinis nostris : subsannationem et derisum his qui in circuitu nostro sunt.

Posuisti nos in similitudinem Gentibus : commotionem capitis in populis.

Tota die verecundia mea contra me est : et confusio faciei meae cooperuit me.

A voce exprobantis et obloquentis : a facie inimici et persequentis.

Hæc omnia venerunt super nos, nec obliti sumus te : et inique non egimus in testamento tuo.

Et non recessit retro cor nostrum : et declinasti semitas nostras a via tua.

Quoniam humiliasti nos in loco afflictionis : et cooperuit nos umbra mortis.

Si obliti sumus nomen Dei nostri : et si expandimus manus nostras ad deum alienum.

Nonne Deus requirit ista ? ipse enim novit abscondita cordis.

Quoniam propter te mortificamur tota die : æstimati sumus sicut oves occisionis.

Exsurge, quare obdormis Domine ? exsurge, et ne repellas in finem.

Quare faciem tuam avertis : oblivisceris inopiæ nostræ et tribulationis nostræ ?

Quoniam humiliata est in pulvere anima nostra : conglutinatus est in terra venter noster.

Exsurge Domine, adjuva nos : et redime nos propter nomen tuum.

said, "Though He slay me, yet will I trust in Him." Thus, taken in its true sense, it may recall to mind our Lord's words respecting the time when the last troubles would come upon Jerusalem ; and those still greater troubles, of which these were a type, upon the City of God in the end of the world : "In your patience possess ye your souls."

Thus the tone of the Psalm is, "The Lord has brought all this woe upon us ; yet though He suffer much more than this to

come upon us, our steps shall not go out of His way : we will trust still in His mercy, and call on Him to show it in His good time." And the actual experience of such persecution in the early Church, drew out from St. Paul an application of this tone when he wrote, "Who shall separate us from the love of Christ ? shall tribulation, or distress, or persecution, or famine, or nakedness, or peril, or sword ? As it is written, For Thy sake we are killed all the day long ; we are accounted as sheep for the

THE XLV PSALM.

Eructavit cor meum.

The IX. Day.
Morning
Prayer.
Christmas Mat-
tins.
Heb. i. 8, 9.
Rev. xix. 11—16.

MY heart is inditing of a good matter : I speak of the things which I have made unto the King.

2 My tongue is the pen : of a ready writer.

3 Thou art fairer than the children of men : full of grace are thy lips, because God hath blessed thee for ever.

Cf. Luke i. 28, in the Greek.

Rev. xix. 11—16.
Isa. ix. 6.

4 Gird thee with thy sword upon thy thigh, O thou most Mighty : according to thy worship and renown.

Heb. iv. 12.
Rev. i. 16. ii. 12.

5 Good luck have thou with thine honour : ride on, because of the word of truth, of meekness, and righteousness; and thy right hand shall teach thee terrible things.

6 Thy arrows are very sharp, and the people shall be subdued unto thee : even in the midst among the King's enemies.

Feb. i. 8.

7 Thy seat, O God, endureth for ever : the sceptre of thy kingdom is a right sceptre.

Feb. i. 9.
John iii. 34.
Luke iv. 16. 19.
Isa. lxi. 1, 2.

8 Thou hast loved righteousness, and hated iniquity : wherefore God, even thy God, hath anointed thee with the oil of gladness above thy fellows.

John xix. 39.
Luke xxiii. 56.
xxiv. 1.
Isa. lxiii. 1, 2.

9 All thy garments smell of myrrh, aloes, and cassia : out of the ivory palaces, whereby they have made thee glad.

PSALMUS XLIV.

Tuesd. Mattins.
Christmas,
App. and Evv.,
1st Noct.
Circumc. and
E. V. M.,
2nd Noct.
All Saints,
3rd Noct.

ERUCTAVIT cor meum verbum bonum : dico ego opera mea Regi.

Lingua mea calamus scribæ : velociter scribentis.

Speciosus forma præ filiis hominum ; diffusa est gratia in labiis tuis : propterea benedixit te Deus in æternum.

Accingere gladio tuo super femur tuum : potentissime,

Specie tua et pulchritudine tua : *Speciem tuam et pulchritudinem tuam* intende, prospere procede, et regna.

Propter veritatem, et mansuetudinem, et justitiam : et deducet te mirabiliter dextera tua.

Sagittæ tuæ acutæ ; populi sub te *potentissime populi in cordis* cadent : in corda inimicorum regis.

Sedes tua, Deus, in sæculum sæculi : *Ὁ θronος σου [LXX]. v. recta est virga reg.* virga directionis virga regni tui.

Dilexisti justitiam et odisti iniquitatem : propterea unxit te Deus tuus, oleo lætitiæ præ consortibus tuis.

Myrrha, et gutta, et cassia a vestimentis tuis, a domibus eburneis : *a gradibus eb.* ex quibus delectaverunt te filie regum in honore tuo.

slaughter. Nay, in all these things we are more than conquerors, through Him that loved us. For I am persuaded that neither death, nor life, nor angels, nor principalities, nor powers, nor things present, nor things to come, nor height, nor depth, nor any other creature, shall be able to separate us from the love of God, which is in Christ Jesus our Lord." [Rom. viii. 35—39.]

PSALM XLV.

For whatever occasion this grand triumphal hymn was composed, the typical application of it is cast into the shade by its fulfilment in Christ: concerning whom, the good WORD of God, it is wholly indited; and to the glory of whose Person and work the praise of the faithful heart flows freely, as from the pen of a scribe swiftly writing.

The use of the Psalm on Christmas Day gives the key to its interpretation as a song of joy and praise respecting the Incarnation: and teaches us to draw out that interpretation even in detail. Thus we sing to Him, "Thou art fairer than the children of men" in respect of the Beauty of the King in His human nature, which was certainly the perfection of moral purity, and

probably of external grace¹. For although He was "made sin for us," yet He "knew no sin," but was spotless altogether in nature, will, and deed; and although His visage was marred more than any man's, by the persecution and suffering He underwent, yet it could not but be that it was fairer than any other countenance in its original and unmarred state. Thus, too, we sing to Him, "Full of grace are Thy lips," remembering how it was said of Him, "Never man spake like this Man" [John vii. 46], and how "all bare Him witness, and wondered at the gracious words which proceeded out of His mouth." [Luke iv. 22.]

The fourth verse refers to the ceremony by which coronation was completed, the girding on of the sword. So when the fulness of the time was come, the WORD of God rides forth conquering and to conquer, girding on His Human Nature,—His Vesture dipped in blood,—on which, and on His thigh, is written

¹ No one can fail to observe the exceptional character of the traditional portrait of Christ with which religious art is pervaded. This is found as the Good Shepherd in the Catacombs, and in many other very ancient forms: and there is probably truth in the representations that there were several contemporary portraits of our Lord taken, with and without miraculous agency, during His earthly life. This traditional countenance of Christ is not Jewish, but a Catholic eclecticism of human beauty.

The IX. Day.
Morning
Prayer.

10 Kings' daughters were among thy honourable women : upon thy right hand did stand the queen in a vesture of gold, wrought about with divers colours.

Isa. lx. 1.

11 Hearken, O daughter, and consider, incline thine ear : forget also thine own people, and thy father's house.

John iii. 29.

12 So shall the King have pleasure in thy beauty : for he is thy Lord God, and worship thou him.

13 And the daughter of Tyre shall be there with a gift : like as the rich also among the people shall make their supplication before thee.

Ezek. xvi. 8-14.
Rev. xii. 1.

14 The King's daughter is all glorious within : her clothing is of wrought gold.

Rev. xxi. 2.
Isa. lx. 13.
Rev. xiv. 1-4.

15 She shall be brought unto the King in raiment of needlework : the virgins that be her fellows shall bear her company, and shall be brought unto thee.

Rev. xix. 7.

16 With joy and gladness shall they be brought : and shall enter into the King's palace.

17 Instead of thy fathers thou shalt have children : whom thou mayest make princes in all lands.

Isa. lx. 20.

18 I will remember thy Name from one generation to another : therefore shall the people give thanks unto thee, world without end.

Astitit Regina a dextris tuis in vestitu deaurato : circumdata varietate. *circumamicta*

Audi, filia, et vide, et inclina aurem tuam : et obliviscere populum tuum, et domum patris tui.

Et concupiscet Rex decorem tuum : *Quoniam concupiscit Rex speciem tuam quia* quoniam ipse est Dominus Deus tuus, et adorabunt eum.

Et filiae Tyri in muneribus : vultum tuum deprecabuntur omnes divites plebis.

Omnis gloria ejus filiae Regis ab intus, in fimbriis aureis : circumamicta varietatibus. *filia regum*

Adducentur Regi virgines post eam : proximae ejus afferentur tibi.

Afferentur in lætitia et exultatione : *(Afferentur) in læt.* adducentur in templum Regis.

Pro patribus tuis nati sunt tibi filii : constitues eos principes super omnem terram.

Memores erunt nominis tui Domine : *et progenie* in omni generatione et generationem. Propterea populi confitebuntur tibi in æternum : et in sæculum sæculi.

the glorious Name which is the Christian fulness of the prophetic "Most Mighty,"—"King of kings and Lord of lords." [Rev. xix. 16.] The effects of the Incarnation are signified by the "terrible" or "wonderful" things achieved by the right hand of the Incarnate Word. Such marvellous works have already been effected as the overthrow of Paganism, the establishment of a sound morality, the first spread and the enduring perpetuity of the Christian Church : such terrible things are yet in store as the second Advent of the Word, the overthrow of Antichrist, the general Resurrection, the last Judgment, and the subjugation of all things to the universal Sovereignty of Christ.

This universal dominion of Christ is further referred to in the seventh verse, which is used in Heb. i. 8, 9, as evidence of the Divine Nature of our Lord : the use of the word "throne" instead of "seat" making the meaning more plain there than in the English version of the Psalm. Such a dominion is prepared for Christ in this dispensation, in the Day of Judgment, and in the perfected Church in glory ; a dominion of a right, erect, straight, or righteous sceptre, ever guiding to the justice and truth of God, and ever opposed to the lawless iniquity of the Evil One.

In the eighth verse the reward of Christ's love in becoming Man is proclaimed, the anointing of His Human Nature with the Holy Ghost given to Him without measure that He might have unlimited power to work out the work of salvation. This

mention of the Anointing of Christ is especially connected with His Human Nature by the mention of "myrrh, aloes, and cassia," which carry the mind to the offerings of the wise men, and to the spices with which the holy body of Jesus was embalmed at His burial¹. This seems the connecting link between the former and the latter verses of the Psalm, the former setting forth the royalty of the Bridegroom, our Lord Jesus Christ ; the latter declaring the royalty of the Bride, His Church.

St. John the Baptist was the first to mention the Bride in New Testament times when he said, "He that hath the Bride is the Bridegroom." [John iii. 29.] Similar phraseology appears in our Lord's earliest words [Mark ii. 19 ; Luke v. 34], and in several of His parables, where He represents the kingdom of Heaven under the figure of marriage. St. Paul speaks of his

¹ It is observable that the anointing oil of the Mosaic dispensation [Exod. xxx. 23] was made of "principal spices" and olive oil. The "principal spices" named are myrrh, sweet cinnamon, sweet calamus, and cassia, the myrrh and cassia being each to weigh as much as both the others put together. This oil was used for anointing the Tabernacle, the vessels, and the priests, including Aaron.

Among the plants of the "garden enclosed" [Song of Solomon iv. 12], the "spring shut up," the "fountain sealed," are spikenard, calamus, cinnamon, frankincense, myrrh, and aloes, with "all the chief spices." Myrrh, aloes, and cinnamon (which is nearly identical with cassia) are also named together in Proverbs vii. 17.

THE XLVI PSALM.

*Deus noster refugium.*The IX. Day.
Morning
Prayer.**G**OD is our hope and strength :
a very present help in trouble.Gen. vii. 11.
viii. 1.2 Therefore wilt we not fear, though
the earth be moved : and though the
hills be carried into the midst of the
sea.3 Though the waters thereof rage
and swell : and though the mountains
shake at the tempest of the same.Isa. lxvi. 12.
Rev. xxii. 1.
Ezek. xlvi. 7. 12.
Joel iii. 18.4 The rivers of the flood thereof
shall make glad the city of God : the
holy place of the tabernacle of the
most Highest.Matt. xviii. 20.
xxviii. 20.5 God is in the midst of her, there-
fore shall she not be removed : God
shall help her, and that right early.6 The heathen make much ado,
and the kingdoms are moved : but
God hath shewed his voice, and the
earth shall melt away.

Matt. i. 23.

7 The Lord of hosts is with us :
the God of Jacob is our refuge.8 O come hither, and behold the
works of the Lord : what destruction
he hath brought upon the earth.

PSALMUS XLV.

DEUS noster refugium et virtus :
adjutor in tribulationibus quæ
invenerunt nos nimis.Tuesd. Mattins.
Epiphany.
3rd Noct.
Dedic. Church,
1st Noct.
B. V. M.,
2nd Noct.Propterea non timebimus dum tur-
babitur terra : et transferentur montes
in cor maris.Sonuerunt et turbatæ sunt aquæ aquæ ejus
eorum : conturbati sunt montes in for-
titudine ejus.Fluminis impetus lætificat civitatem
Dei : sanctificavit tabernaculum suum
Altissimus.Deus in medio ejus ; non commo-
vebitur : adjuvabit eam Deus mane
diluculo.adjuravit eam
Deus vultu suoConturbatæ sunt Gentes, et incli-
nata sunt regna : dedit vocem suam,
mota est terra.

Altissimus et mota

Dominus virtutum nobiscum : sus-
ceptor noster Deus Jacob.Venite et videte opera Domini :
quæ posuit prodigia super terram.

earnest desire to present the Church as "a chaste virgin" to Christ [2 Cor. xi. 2], and likens the union between it and Christ to the union of husband and wife. [Eph. v. 23—32.] But, above all, the tone of this Psalm is taken up in the latter chapters of the Revelation, "Let us be glad and rejoice, and give honour to Him : for the marriage of the Lamb is come, and His wife hath made herself ready." [Rev. xix. 7.] "And I John saw the holy city, new Jerusalem, coming down from God, out of heaven, prepared as a bride adorned for her husband." [Ibid. xxi. 2.] "And there came unto me one of the seven angels . . . saying, Come hither, I will show thee the bride, the Lamb's wife. And he carried me away in the Spirit to a great and high mountain, and showed me that great city, the holy Jerusalem, descending out of heaven from God." [Ibid. 9.]

And as the King, the Incarnate Word, is fairer than the children of men in natural beauty of body and soul, so the Queen on His right hand is also represented as being adorned with all that can make fit to stand before Him, as well as being "all glorious within." Though the Church is "clothed with the sun" [Rev. xii. 1] in a spiritual sense, yet in a literal sense also she is to have all that external splendour which is typified by clothing of wrought gold and raiment of needlework ; a vesture of gold, wrought about with divers colours, reflecting the glory of the Bridegroom's "vesture dipped in blood¹."

In this Psalm, therefore, the Church ever offers a hymn of thanksgiving to Christ for that Betrothal of Himself to His Mystical Body which will be perfected by the final assumption of the Bride to His right hand in Heaven. Girt with the sword

of His Human Nature, and clad with transfigured garments which are still perfumed with the myrrh, aloes, and cassia of His atoning work, the King of Glory stands prepared to receive to His side the Church which He has espoused ; that as a Queen she may enter into His palace, as a Queen be crowned with a never-fading beauty, and as a Queen reign with Him, "having the glory of God." [Rev. xxi. 11.]

PSALM XLVI.

As the kingdoms of this world shall become the kingdom of the Lord and of His Christ, so the waters which rage and swell and shake the earth to its foundations, shall be subdued at the Divine command, "Be still," and become the river which makes glad the City of God. "There shall be no more sea," to trouble the Church [Rev. xxi. 1] ; but there shall be "a pure river of water of life, clear as crystal, proceeding out of the throne of God and the Lamb" [Ibid. xxii. 1], and "every thing shall live whither the river cometh." [Ezek. xlvi. 8.]

Such is the mystical strain which this Psalm carries up to the praise of God. The ordinary antagonism of the world may embarrass the Church, or active persecution trouble it, but the Spirit of God moves upon the face of the waters to bring life out of death ; God will remember Noah, to make that by which He brings destruction upon the earth, be also the salvation of His Church. Christ, though asleep, is yet in the ship of the Apostles, ready to rebuke the winds and the waves, and to say, "Peace, be still."

Grant, O Lord, we beseech Thee, that the course of this world may be so peaceably ordered by Thy governance, that Thy Church may joyfully serve Thee in all godly quietness, through Jesus Christ our Lord. Amen.

¹ There is an accidental coincidence of a very striking character between this Christmas Mattins Psalm and the first lesson on Christmas Eve, which is Isaiah lx. See also p. 76.

The IX. Day.
Morning Prayer.
Isa. ii. 4.
Micah iv. 3.

9 He maketh wars to cease in all the world : he breaketh the bow, and knappeth the spear in sunder, and burneth the chariots in the fire.

Mark iv. 39.

10 Be still then, and know that I am God : I will be exalted among the heathen, and I will be exalted in the earth.

11 The Lord of hosts is with us : the God of Jacob is our refuge.

THE XLVII PSALM.

Omnes gentes, plaudite.

Evening Prayer.
Ascens. Evensong.

O CLAP your hands together, all ye people : O sing unto God with the voice of melody.

Isa. xl. 5.
Luke ii. 32.

2 For the Lord is high, and to be feared : he is the great King upon all the earth.

3 He shall subdue the people under us : and the nations under our feet.

1 Pet. i. 4.

4 He shall choose out an heritage for us : even the worship of Jacob, whom he loved.

Luke xxiv. 51, 52.
Eph. iv. 8.

5 God is gone up with a merry noise : and the Lord with the sound of the trump.

6 O sing praises, sing praises unto our God : O sing praises, sing praises unto our King.

Rev. iv. 9.

7 For God is the King of all the earth : sing ye praises with understanding.

8 God reigneth over the heathen : God sitteth upon his holy seat.

Rev. xi. 15.
Eph. ii. 14—22.
Gen. xv. 1.

9 The princes of the people are joined unto the people of the God of Abraham : for God, which is very high exalted, doth defend the earth, as it were with a shield.

THE XLVIII PSALM.

Magnus Dominus.

Whitsunday
Mattins.

GREAT is the Lord, and highly to be praised : in the city of our God, even upon his holy hill.

Auferens bella usque ad finem terræ : arcum conteret, et confringet arma ; et scuta comburet igni.

Vacate, et videte quoniam ego sum Deus : exaltabor in Gentibus, et exaltabor in terra.

Dominus virtutum nobiscum : susceptor noster Deus Jacob.

PSALMUS XLVI.

OMNES Gentes plaudite manibus : jubilate Deo in voce exultationis.

Tuesd. Mattins.
Epiphany,
1st Noct.
Trinity Sund.,
App. and Evv.,
2nd Noct.
Deus summus terribilis . . . super omnes deos

Quoniam Dominus excelsus terribilis : Rex magnus super omnem terram.

Subjecit populos nobis : et gentes sub pedibus nostris.

Elegit nobis hæreditatem suam : speciem Jacob quam dilexit.

Ascendit Deus in júbilo : et Dominus in voce tubæ. *jubilatione*

Psallite Deo nostro, psallite : psallite Regi nostro, psallite.

Quoniam Rex omnis terræ Deus : psallite sapienter.

Regnabit Deus super Gentes : Deus sedet super sedem sanctam suam. *Dominus super omnes*

Principes populorum congregati sunt cum Deo Abraham : quoniam dii fortes terræ vehementer elevati sunt. *populi congregaverunt nimium*

PSALMUS XLVII.

Tuesd., Whitsun Eve and Day, Mattins.
Christmas, Circumc., Trinity Sund., Dedic. Ch., 2nd Noct.

MAGNUS Dominus, et laudabilis nimis : in civitate Dei nostri, in monte sancto ejus.

PSALM XLVII.

This is a hymn of triumph, not for any temporal victory of Christ's Church, but for that glorious work of peace, by which the fold of the Good Shepherd is being extended that it may embrace all races of mankind. As holy Simeon saw that the Sun of Righteousness had arisen to be a Light to lighten the Gentiles, as well as God's ancient people Israel, so the prophet had been inspired to tell of the then distant age of the Messiah, that "God reigneth over the heathen," and, that "the princes of

the people," beyond the bounds of the chosen race, are joined unto the people of the God of Abraham.

The selection of this Psalm for Ascension Day is connected partly with the ordinary interpretation of the fifth verse, but not less with the general tone of victory which pervades the whole, and which is so suitable to the leading of captivity captive by Christ when He ascended up on high, to reign over the people whom He had bought with a price, and to place His Human Nature on the holy throne of Divine majesty and power.

It is a song of trust also in Christ, in which the Church declares

The IX. Day.
Evening
Prayer.
Matt. v. 35.

2 The hill of Sion is a fair place, and the joy of the whole earth : upon the north-side lieth the city of the great King ; God is well known in her palaces as a sure refuge.

Rev. xi. 2.
xviii. 2.

3 For lo, the kings of the earth : are gathered and gone by together.

Isa. ii. 11.

4 They marvelled to see such things : they were astonished, and suddenly cast down.

Rev. xviii. 10. 15.

5 Fear came there upon them, and sorrow : as upon a woman in her travail.

Isa. ii. 16.
Rev. xviii. 17.

6 Thou shalt break the ships of the sea : through the east-wind.

7 Like as we have heard, so have we seen in the city of the Lord of hosts, in the city of our God : God upholdeth the same for ever.

Acts ii. 1.

8 We wait for thy loving-kindness, O God : in the midst of thy temple.

9 O God, according to thy Name, so is thy praise unto the world's end : thy right hand is full of righteousness.

10 Let the mount Sion rejoice, and the daughter of Judah be glad : because of thy judgements.

Rev. xxi. 10—27.

11 Walk about Sion, and go round about her : and tell the towers thereof.

Ezek. xl. 4.

12 Mark well her bulwarks, set up her houses : that ye may tell them that come after.

13 For this God is our God for ever and ever : he shall be our guide unto death.

THE XLIX PSALM.

• *Audite hæc, omnes.*

O HEAR ye this, all ye people : ponder it with your ears, all ye that dwell in the world ;

Fundatur exultatione universæ terræ *Dilatans exultationis*
mons Sion : latera aquilonis, civitas Regis magni.

Deus in domibus ejus cognoscetur : *in gradibus ejus dinoscitur*
cum suscipiet eam.

Quoniam ecce reges terræ congregati sunt : convenerunt in unum.

Ipsi videntes sic admirati sunt, conturbati sunt, commoti sunt : tremor apprehendit eos.

Ibi dolores ut parturientis : *in spiritu sicut parturientis*
vehementi conteres naves Tharsis.

Sicut audivimus, sic vidimus in civitate Domini virtutum, in civitate Dei nostri : Deus fundavit eam in æternum.

Suscepimus, Deus, misericordiam tuam : in medio templi tui.

Secundum Nomen tuum, Deus, sic et laus tua in fines terræ : justitia plena est dextera tua.

Lætetur mons Sion, et exsultent filia Judæ : propter judicia tua, Domine.

Circumdate Sion, et complectimini eam : narrate in turribus ejus.

Ponite corda vestra in virtute ejus : et distribuite domos ejus ; ut enarretis *gradus ejus*
in progenie altera.

Quoniam hic est Deus, Deus noster *hic est Deus noster*
in æternum, et in sæculum sæculi : ipse reget nos in sæcula.

PSALMUS XLVIII.

A UDITE hæc, omnes gentes : *Tuesd. Mattins.*
auribus percipite omnes qui habitatis orbem.

that, as the "word of the Lord came unto Abram in a vision, saying, Fear not, Abram, I am thy shield, and thy exceeding great reward," so will the same WORD, God, which is very high exalted, ever defend as with a shield the inheritance which He has won for His own.

PSALM XLVIII.

Much light is thrown upon this Psalm, by comparing together the two chapters of the Revelation in which are described the fall of the mystical city Babylon, and the establishment for ever of the New Jerusalem. The eighteenth chapter expands the third and following three verses of the Psalm into a fearful description of a sudden destruction, and privation of the Light

and Presence of God : "Alas, alas that great city, that was clothed in fine linen, and purple, and scarlet, and decked with gold, and precious stones, and pearls ! For in one hour so great riches is come to nought. . . . And the light of a candle shall shine no more at all in thee ; and the voice of the bridegroom and of the bride shall be heard no more at all in thee." [Rev. xviii. 16. 23.] The Holy City, on the other hand, whose foundations were laid at Pentecost, is seen descending from God, "prepared as a bride adorned for her husband . . . and the city had no need of the sun, neither of the moon, to shine in it ; for the glory of God did lighten it, and the Lamb is the Light thereof . . . they need no candle, neither light of the sun ; for the Lord God giveth them light." [Ibid. xxi. 2. 23 ; xxii. 5.]

The IX. Day. <i>Evening Prayer.</i> Prov. viii. 6.	2 High and low, rich and poor : one with another. 3 My mouth shall speak of wisdom : and my heart shall muse of under- standing.	Quique terrigenæ, et filii hominum : simul in unum dives et pauper. Os meum loquetur sapientiam : et meditatio cordis mei prudentiam.
Ezek. xvii. 2.	4 I will incline mine ear to the parable : and shew my dark speech upon the harp.	Inclinabo in parabolam aurem <small>ad similitudinem</small> meam : aperiã in psalterio proposi- tionem meam.
Gen. iii. 15.	5 Wherefore should I fear in the days of wickedness : and when the wickedness of my heels compasseth me round about ?	Cur timebo in die mala ? iniquitas calcanei mei circumdabit me. <small>circumdedit</small>
Mark x. 23, 24. Dan. iv. 30.	6 There be some that put their trust in their goods : and boast themselves in the multitude of their riches.	Qui confidunt in virtute sua : et in <small>quique in abun-</small> multitudine divitiarum suarum glori- <small>dantia . . . gloria</small> antur, <small>buntur</small>
Isa. lix. 16.	7 But no man may deliver his brother : nor make agreement unto God for him ; 8 For it cost more to redeem their souls : so that he must let that alone for ever ; 9 Yea, though he live long : and see not the grave.	Frater non redimit ; redimet homo : <small>redimit homo</small> non dabit Deo placationem suam, Et pretium redemptionis animæ <small>Nec pret.</small> sua : et laborabit in æternum, et vivet adhuc in finem.
Eccles. ii. 15, 16.	10 For he seeth that wise men also die, and perish together : as well as the ignorant and foolish, and leave their riches for other.	Non videbit interitum cum viderit <small>Quoniam non vid.</small> sapientes morientes : simul insipiens et stultus peribunt.
Luke xii. 16-20.	11 And yet they think that their houses shall continue for ever : and that their dwelling-places shall endure from one generation to another ; and call the lands after their own names. 12 Nevertheless, man will not abide in honour : seeing he may be com- pared unto the beasts that perish ; this is the way of them.	Et relinquent alienis divitias suas : et sepulchra eorum domus illorum in æternum. Tabernacula eorum in progenie et <small>in generatione et</small> progenie : vocaverunt nomina sua in <small>invocabunt</small> terris suis. Et homo, cum in honore esset, non intellexit : comparatus est jumentis insipientibus, et similis factus est illis.
Luke xii. 21.	13 This is their foolishness : and their posterity praise their saying.	Hæc via illorum scandalum ipsis : et postea in ore suo complacebunt. <small>benedicent</small>

While therefore the city of Antichrist, which says in its pride, "I shall be a lady for ever" [Isa. xlvii. 7], is a marvel to see, because of its gigantic ruin, the City of God, the Temple of the Holy Ghost, shall stand firm in all its towers and bulwarks, because God Himself upholds it, and dwells in the midst of its streets.

PSALM XLIX.

The "parable" and "dark speech" of this Psalm appear to refer to the vision of a better resurrection which upholds the faithful soul when depressed by adversity. The strain of the Psalm is, Look not at the outward prosperity of this life, as that which is most to be desired, and the loss of which is most to be lamented ; but rather look to that deliverance from eternal misery [v. 15], and that reception into the Presence of God, which will be the only true and enduring prosperity. Until Christ brought life and immortality to light by the Gospel, it was only in parables and dark sayings that they were made known to the world, and

even the seventh and fifteenth verses speak of redemption and a future life of blessedness only in negative and enigmatical terms. Such parables and enigmas have, however, received their interpretation by the word and work of Christ ; and thus an additional force is given to them as they are used in the Church. God has revealed even to babes the truths that were hidden from the wise and prudent of old, and every Christian can behold the unveiling of mysteries, which prophets and kings looked into without understanding. And thus, when we sing that no man may deliver his brother, we do it in the knowledge that One has made Himself our Brother, to redeem us by making an atonement with God for us ; and when, "But God hath delivered My soul from the place of hell ; for He shall receive Me," we know that we are speaking of Him Who lay in darkness and the shadow of death, that He might make us the children of God, and exalt us to everlasting life. He is the Righteous Who could say, "All souls are Mine," and could have domination over them, to lead captivity captive, in the morning of His Resurrection.

The IX. Day.
Evening
Prayer.
Luke xvi. 23. 25.
14 They lie in the hell like sheep, death gnaweth upon them, and the righteous shall have domination over them in the morning : their beauty shall consume in the sepulchre out of their dwelling.

Isa. xxv. 8.
15 But God hath delivered my soul from the place of hell : for he shall receive me.

16 Be not thou afraid, though one be made rich : or if the glory of his house be increased ;

Luke xvi. 19. 23.
17 For he shall carry nothing away with him when he dieth : neither shall his pomp follow him.

Luke xvi. 25.
18 For while he lived, he counted himself an happy man : and so long as thou doest well unto thyself, men will speak good of thee.

Prov. iv. 19.
19 He shall follow the generation of his fathers : and shall never see light.

Dan. iv. 33.
20 Man being in honour hath no understanding : but is compared unto the beasts that perish.

THE L. PSALM.

Deus deorum.

The X. Day.
Morning
Prayer.
Mal. i. 11.
THE Lord, even the most mighty God, hath spoken : and called the world, from the rising up of the sun unto the going-down thereof.

Mal. iii. 2.
Heb. xii. 22.
2 Out of Sion hath God appeared : in perfect beauty.

Heb. xii. 29.
3 Our God shall come, and shall not keep silence : there shall go before him a consuming fire, and a mighty tempest shall be stirred up round about him.

Isa. i. 2.
Rev. xx. 12.
1 Pet. iv. 17.
4 He shall call the heaven from above : and the earth, that he may judge his people.

Sicut oves in inferno positi sunt : mors depascet eos.

Et dominabuntur eorum iusti in matutino : et auxilium eorum veterascet in inferno a gloria eorum. *obtinebunt eos iusti et a gloria sua expulsi sunt*

Veruntamen Deus redimet animam meam de manu inferi : cum acceperit me. *Deus liberabit*

Ne timueris cum dives factus fuerit homo : et cum multiplicata fuerit gloria domus ejus.

Quoniam cum interierit, non sumet omnia : neque descendet cum eo gloria ejus. *non cum morietur accipiet hæc omnia neque simul descendit cum eo gloria domus ejus*

Quia anima ejus in vita ipsius benedicetur : confitebitur tibi cum benefeceris ei.

Introibit usque in progenies patrum suorum : et usque in æternum non videbit lumen.

Homo, cum in honore esset, non intellexit : comparatus est jumentis insipientibus, et similis factus est illis.

PSALMUS XLIX.

DEUS deorum Dominus locutus est : et vocavit terram, *Tuesd. Mattins.*

A solis ortu usque ad occasum : ex Sion species decoris ejus.

Deus manifeste veniet : Deus noster, et non silebit.

Ignis in conspectu ejus exardescet : et in circuitu ejus tempestas valida. *ardebit*

Advocavit cælum desursum : et terram, discernere populum suum. *ut discerneret*

There is an obvious association of ideas between this Psalm and our Blessed Lord's parables of the rich fool, and of Dives and Lazarus. The one thought that his house should continue for ever, but while he was planning for the future heard the voice, "This night shall thy soul be required of thee," and was compared unto the beasts that perish. The other "was clothed in purple, and fine linen, and fared sumptuously every day," yet carried nothing away with him, neither did his pomp follow him ; for it was in hell and in torment that he opened the eyes which had been closed by death. But though a Job or a Lazarus may be compassed about with the consequences of that sin which bruised the heel even of the Second Adam, he may say, "Wherefore should I fear?" "I know that my Redeemer liveth, and that He shall stand at the latter day upon the earth ; and though worms de-

stroy this body, yet in my flesh shall I see God." And thus, while the wicked follows the generation of his fathers, and shall never see light, they that live in Christ follow the generation of the New birth, and walking in the path of light which He will show them, attain at last to the perfect Day.

PSALM L.

This Psalm proclaims the Advent of the Son of God to establish a new covenant between God and man. In the old covenant the voice of the Lord was heard from Sinai by a single nation, but in the new covenant He speaks to the whole world, and sends forth His invitation "from the rising up of the sun unto the going down thereof." But, although it declares the Advent of Christ in the "perfect beauty" of the Incarnation, it sets Him forth

<p>The X. Day. <i>Morning</i> <i>Prayer.</i> Rev. xiv. 16.</p>	<p>5 Gather my saints together unto me : those that have made a covenant with me with sacrifice.</p>	<p>Congregate illi sanctos ejus : qui <small>illie sanctos . . . ordinaverunt</small> ordinant testamentum ejus super sacrificia.</p>	<p>Et annuntiabunt cœli justitiam ejus : quoniam Deus judex est.</p>
<p>Rev. xv. 3, 4. xix. 2. John v. 22. 27.</p>	<p>6 And the heavens shall declare his righteousness : for God is Judge himself.</p>	<p>Audi populus meus, et loquar ; Israëli, et testificabor tibi : Deus, Deus <small>quoniam Deus tuus, ego sum.</small></p>	<p>Non in sacrificiis tuis arguam te : <small>super sacrificia tua</small> holocausta autem tua in conspectu meo sunt semper.</p>
<p>Rev. xxi. 3.</p>	<p>7 Hear, O my people, and I will speak : I myself will testify against thee, O Israel ; for I am God, even thy God.</p>	<p>Non accipiam de domo tua vitulos : neque de gregibus tuis hircos.</p>	<p>Quoniam meæ sunt omnes feræ silvarum : jumenta in montibus et boves.</p>
<p>Isa. I. 11.</p>	<p>8 I will not reprove thee because of thy sacrifices, or for thy burnt-offerings : because they were not alway before me.</p>	<p>Cognovi omnia volatilia cœli : et pulchritudo agri mecum est. <small>species agri</small></p>	<p>Si esuriero non dicam tibi : meus est enim orbis terræ et plenitudo ejus.</p>
<p>Mal. iii. 1.</p>	<p>9 I will take no bullock out of thine house : nor he-goat out of thy folds.</p>	<p>Immolabo Deo sacrificium laudis : et redde Altissimo vota tua.</p>	<p>Et invoca me in die tribulationis : <small>trib. tua ut eripiam te et magnificabis me</small> eruum te et honorificabis me.</p>
<p>Mal. iii. 7. 14.</p>	<p>10 For all the beasts of the forest are mine : and so are the cattle upon a thousand hills.</p>	<p>Peccatori autem dixit Deus, Quare tu enarras justitias meas : et assumis testamentum meum per os tuum ?</p>	<p>Tu vero odisti disciplinam : et projecisti sermones meos retrorsum. <small>serm. post te</small></p>
<p>Mal. iii. 5.</p>	<p>11 I know all the fowls upon the mountains : and the wild beasts of the field are in my sight.</p>	<p>Si videbas furem, currebas cum eo : <small>simul currebas</small> et cum adulteris portionem tuam ponebas.</p>	<p>12 If I be hungry, I will not tell thee : for the whole world is mine, and all that is therein.</p>
<p>Mal. iii. 5.</p>	<p>13 Thinkest thou that I will eat bulls' flesh : and drink the blood of goats ?</p>	<p>18 When thou sawest a thief, thou consentedst unto him : and hast been partaker with the adulterers.</p>	<p>14 Offer unto God thanksgiving : and pay thy vows unto the most Highest.</p>
<p>Mal. iii. 5.</p>	<p>15 And call upon me in the time of trouble : so will I hear thee, and thou shalt praise me.</p>	<p>17 Whereas thou hatest to be reformed : and hast cast my words behind thee ?</p>	<p>18 When thou sawest a thief, thou consentedst unto him : and hast been partaker with the adulterers.</p>

especially in that character to which our Lord referred when He said, "The Father hath committed all judgment unto the Son." And hence the Psalm is a continual witness, that, although we are come to the "Mount Zion" of mercy, and not to the mount which burned with the fire of judgment, yet the dispensation of the Son of Man is a continuous dispensation of judgment even in this life. Our righteous Judge is judging His people while the day of grace is still theirs, saying even to His saints, and those that have made a covenant with Him, with the sacrifice of the New Dispensation, "Hear, O My people, and I will speak. . . . Consider this, lest I pluck you away, and there be none to deliver

you." This judgment is, therefore, as far as it relates to the present life, our Lord's merciful appeal to the consciences of His people, by which He is striving to bring them to penitence, love, and a closer walk with Him. At the same time, as His prophetic words concerning the destruction of Jerusalem had a further reference to the end of the world, so, when speaking of judging His people in this life, He refers also to that final and irrevocable judgment, from which, if He have not saved, there is none to deliver. Thus we are reminded of His words as He wept over the Holy City, "How often would I have gathered thy children together, as a hen doth gather her brood under her wings;" or

The X. Day.
Morning
Prayer.

19 Thou hast let thy mouth speak wickedness : and with thy tongue thou hast set forth deceit.

20 Thou satest, and spakest against thy brother : yea, and hast slandered thine own mother's son.

Luke xix 22.

21 These things hast thou done, and I held my tongue, and thou thoughtest wickedly, that I am even such a one as thy self : but I will reprove thee, and set before thee the things that thou hast done.

Isa. i. 18.

22 O consider this, ye that forget God : lest I pluck you away, and there be none to deliver you.

Mal. i. 11.

23 Whoso offereth me thanks and praise, he honoureth me : and to him that ordereth his conversation right will I shew the salvation of God.

THE LI PSALM.

Miserere mei, Deus.

Ash-Wednesday,
Commination.
A penitential
Psalm.

HAVE mercy upon me, O God, after thy great goodness : according to the multitude of thy mercies do away mine offences.

Zech. xlii. 1.

2 Wash me thoroughly from my wickedness : and cleanse me from my sin.

3 For I acknowledge my faults : and my sin is ever before me.

Luke xv. 21.
Rom. iii. 4, 5.

4 Against thee only have I sinned, and done this evil in thy sight : that thou mightest be justified in thy saying, and clear when thou art judged.

Rom. iii. 23.
2 Pet. i. 4.

5 Behold, I was shapen in wickedness : and in sin hath my mother conceived me.

Os tuum abundavit malitia : et nequitia lingua tua concinnabat dolos.

Sedens adversus fratrem tuum loquebaris : et adversus filium matris tuæ ponebas scandalum ; hæc fecisti, et tacui.

Existimasti inique quod ero tui similis : arguam te, et statuam contra faciem tuam.

Intelligite hæc, qui obliviscimini Deum : nequando rapiat, et non sit qui eripiat.

Sacrificium laudis honorificabit me : et illic iter quo ostendam illi salutare Dei.

PSALMUS L.

MISERERE mei, Deus : secundum magnam misericordiam tuam.

Ferial Lauds.
Lauds of the departed.

Et secundum multitudinem miserationum tuarum : dele iniquitatem meam.

Amplius lava me ab iniquitate mea : et a peccato meo munda me.

ab injustitia mea
et a delicto meo

Quoniam iniquitatem meam ego cognosco : et peccatum meum contra me est semper.

agnosco et delictum meum
coram me

Tibi soli peccavi, et malum coram te feci : ut justificeris in sermonibus tuis, et vincas cum judicaris.

Ecce enim in iniquitatibus conceptus sum : et in peccatis concepit me mater mea.

in delictis peperit

of His words spoken by the prophet, "Come, now, and let us reason together, saith the Lord; Though your sins be as scarlet, they shall be as white as snow; though they be red like crimson, they shall be as wool. If ye be willing and obedient, ye shall eat the good of the land."

The references to sacrifices which this Psalm contains, are to be taken in two senses. First, they speak of the unacceptableness of offerings made in hypocrisy, and which are not accompanied by penitence, obedience, and love; offerings which are again repudiated by God in the penitential Psalm that follows: "To what purpose is the multitude of your sacrifices unto Me? saith the Lord: I am full of the burnt-offerings of rams, and the fat of fed beasts; and I delight not in the blood of bullocks, or of lambs, or of he goats. . . . Bring no more vain oblations; incense is an abomination unto Me." [Isa. i. 11-13.] Secondly, they look prophetically to the passing away of the old dispensation, which was founded on a system of sacrifices wherein slain animals were offered, and to the coming in of the new dispensa-

tion, which is founded on the once-offered sacrifice of Christ, presented before God continually in Heaven, and re-presented on earth, in the sacrifice of the Holy Eucharist. Thus, "Offer unto God thanksgiving," and, "Whoso offereth Me thanks and praise, he honoureth Me," look to that of which the prophet Malachi spoke when, after saying, "I have no pleasure in you, saith the Lord of hosts, neither will I accept an offering at your hand," he added, "For from the rising of the sun even unto the going down of the same, My Name shall be great among the Gentiles; and in every place incense shall be offered unto My Name, and a pure offering: for My Name shall be great among the heathen, saith the Lord of hosts." [Mal. i. 11.]

PSALM LI.

Such was the completeness of our Blessed Redeemer's identification of Himself with our nature, that even these words of deep and sorrowing penitence are His words, spoken as the Representative of all sinners. God laid upon Him the iniquities of us all, and

The X. Day.
*Morning
Prayer.*

6 But lo, thou requirest truth in the inward parts : and shalt make me to understand wisdom secretly.

Lev. xiv. 1—9.
Numb. xix. 11—20.
Mark xvi. 16.
John iii. 5.
xiii. 10.

7 Thou shalt purge me with hyssop, and I shall be clean : thou shalt wash me, and I shall be whiter than snow.

Luke xv. 7. 22.

8 Thou shalt make me hear of joy and gladness : that the bones which thou hast broken may rejoice.

9 Turn thy face from my sins : and put out all my misdeeds.

Matt. v. 8.
Jer. xxiv. 7.

10 Make me a clean heart, O God : and renew a right spirit within me.

Ezek. xviii. 31.
xi. 19.
xxxvi. 26.

11 Cast me not away from thy presence : and take not thy holy Spirit from me.

12 O give me the comfort of thy help again : and stablish me with thy free Spirit.

13 Then shall I teach thy ways unto the wicked : and sinners shall be converted unto thee.

14 Deliver me from blood-guiltiness, O God, thou that art the God of my health : and my tongue shall sing of thy righteousness.

Mattins and
Evensong Ver-
sicles.

15 Thou shalt open my lips, O Lord : and my mouth shall shew thy praise.

16 For thou desirest no sacrifice, else would I give it thee : but thou delightest not in burnt-offerings.

17 The sacrifice of God is a troubled spirit : a broken and contrite heart, O God, shalt thou not despise.

Ecce enim veritatem dilexisti : incerta et occulta sapientiæ tuæ manifestasti mihi.

Asperges me, Domine, hyssopo, et mundabor : lavabis me, et super nivem dealbabor.

Auditui meo dabis gaudium et lætiti-
tiam : et exsultabunt ossa humiliata.

Averte faciem tuam a peccatis meis :
et omnes iniquitates meas dele.

Cor mundum crea in me, Deus : et
spiritum rectum innova in visceribus
meis.

Ne projicias me a facie tua : et
spiritum sanctum tuum ne auferas a
me.

Redde mihi lætitiã salutãris tui :
et spiritu principali confirma me.

Docebo iniquos vias tuas : et impij
ad te convertentur.

Libera me de sanguinibus, Deus,
Deus salutis meæ : et exsultabit lingua
mea justitiã tuã.

Domine, labia mea aperies : et os
meum annuntiabit laudem tuã.

Quoniam si veluisses sacrificium,
dedissem : utique holocaustis non de-
lectaberis.

Sacrificium Deo spiritus contribu-
latus : cor contritum et humiliatum,
Deus, non despicias.

non spernit

thus He speaks as One in whom all the woes of mankind, all original and all actual sin, were for the time condensed into a focus, that, by the intensity of His penitence, they might be brought within the reach of mercy and pardon. Hence, all the millions of mankind that have inherited sin from the first Adam, are brought before the all-righteous Judge in the Person and by the voice of the Second Adam, Who says for them, and not for Himself, "Have mercy upon Me," "Do away Mine offences," "Wash Me," "Cleanse Me." Have mercy upon Me, for in Me Thou dost behold not Thy sinless Son alone, but Him whom Thou hast made sin for all Thy sinful children. Do away Mine offences, for not only am I Thy Son, in Whom is no guile, but the new Head and Leader and Representative of Thine offending offspring. Wash Me, Whose Immaculate Conception left no need for baptism, and cleanse Me, Who have no defilement of My Nature, for I am made like unto My brethren in all things, that I may win purity for them. I acknowledge My faults, for theirs have I taken on Me, and My sin is ever before Me, for the burden of their sin weighs Me down from My cradle in the manger at Bethlehem to My Cross on the hill of Calvary. O be favourable

and gracious unto Thy Sion, and build Thou the walls of Thy New Jerusalem, that the Eucharists of My atoning Sacrifice may ever be presented before Thee, and in that and in them all other sacrifices find their fulfilment, their completion, and their climax.

It is only in the way thus indicated that a full explanation can be given of (1) the deep and intense spirit of self-accusation ; (2) the entire confidence in the cleansing power of God ; and (3) the sense of most intimate relation between Himself and His Judge, by which the penitent's words in this Psalm are so strikingly characterized. In his degree, and that a very high degree, David was a type of our atoning Lord when he uttered this Psalm, and thus his tone of penitence so far exceeded that which ordinary sinners could thoroughly assume : but David's penitence was that of an actual sinner, who could say literally of himself individually, that he was shapen in wickedness, that his mother had conceived him with the taint of original sin, that he needed purging with hyssop from the leprosy of actual sin, and deliverance from blood-guiltiness. The personal sinlessness of the Lamb of God aggravated the pain of the burden laid upon Him,

The X. Day.
Morning
Prayer.
Rev. xxi. 14, 17,
18.

18 O be favourable and gracious unto Sion : build thou the walls of Jerusalem.

19 Then shalt thou be pleased with the sacrifice of righteousness, with the burnt-offerings and oblations : then shall they offer young bullocks upon thine altar.

THE LII PSALM.

Quid gloriaris ?

2 Thess. ii. 4.
Rev. xiii. 6, 7, 13.

WHY boastest thou thy self, thou tyrant : that thou canst do mischief ;

2 Whereas the goodness of God : endureth yet daily ?

2 Thess. ii. 9.
Isa. ix. 15.

3 Thy tongue imagineth wickedness : and with lies thou cuttest like a sharp razor.

1 Tim. iv. 2.

4 Thou hast loved unrighteousness more than goodness : and to talk of lies more than righteousness.

5 Thou hast loved to speak all words that may do hurt : O thou false tongue.

Job xix. 10.
Jude 12.
Rev. xx. 21.

6 Therefore shall God destroy thee for ever : he shall take thee, and pluck thee out of thy dwelling, and root thee out of the land of the living.

7 The righteous also shall see this, and fear : and shall laugh him to scorn.

Rev. xiii. 17.

8 Lo, this is the man that took not God for his strength : but trusted unto the multitude of his riches, and strengthened himself in his wickedness.

Benigne fac, Domine, in bona voluntate tua Sion : ut ædificentur muri Hierusalem.

Tunc acceptabis sacrificium justitiæ, oblationes et holocausta : tunc impo-
nent super altare tuum vitulos.

PSALMUS LI.

QUID gloriaris in malitia : qui potens es in iniquitate ? Tuesd. Mattins.

Tota die injustitiam cogitavit lingua tua : sicut novacula acuta fecisti dolum.

Dilexisti malitiam super benignitatem : iniquitatem magis quam loqui æquitatem.

Dilexisti omnia verba præcipitationis : lingua dolosa. in lingua

Propterea Deus destruet te in finem : evellet te, et emigrabit te de tabernaculo tuo ; et radicem tuam de terra viventium.

Videbunt justi et timebunt, et super eum ridebunt, et dicent : Ecce homo qui non posuit Deum adiutorem suum :

Sed speravit in multitudine divitarum suarum : et prævaluit in vanitate sua.

and also enabled Him to see the whole of God's hatred for sin as no actual sinner could¹. And thus when He "was made sin for us," that He might make intercession for us by a vicarious penitence, the intensity of the words of penitence was in proportion to His thorough and penetrative perception of its necessity. As He was set forth to us for an example of innocence, so He is also set forth for an example of penitence ; and hence, where we should least expect it, in Him Who knew no sin, we find the perfect Pattern which the sinner is to copy when he comes before God confessing his transgressions, praying for pardon, promising amendment of life, and faithfully expecting a perfect absolution.

Part of the tenth, eleventh, and fifteenth verses of this Psalm are daily used as versicles at Mattins and Evensong. The whole Psalm was formerly used every day except Sunday.

¹ This explains "Against Thee only have I sinned." In the depth of His vicarious penitence, the offence against God becomes so blindingly apparent that the offence against man is for the time invisible.

PSALM LII.

The title of this Psalm connects it with the iniquitous acts of Doeg in slaying Ahimelech and a multitude of other priests and their families at the command of Saul. [1 Sam. xxii. 18, 19.] By this wicked act both Saul and Doeg constituted themselves types of Antichrist, and the words spoken against them by the Psalmist derive a part of their force from the fact that they are also a prophecy respecting the great enemy of the Lord, and of His Church. This gives the key to the strong language respecting the "lies" of the "tyrant" by which the Psalm is characterized ; for the whole rule of Antichrist will reflect the one great lie set up in his person, when "he as God sitteth in the temple of God, showing himself that he is God." [2 Thess. ii. 4.] But the "sharp razor" of Antichrist will be vanquished by the "two-edged sword" [Rev. i. 16] of truth, which proceeds out of the mouth of "the WORD of God." [Ibid. xix. 13. 2 Thess. ii. 8.]

The X. Day.
Morning
Prayer.
Jer. xi. 16.

9 As for me, I am like a green olive-tree in the house of God : my trust is in the tender mercy of God for ever and ever.

10 I will always give thanks unto thee for that thou hast done : and I will hope in thy Name, for thy saints like it well.

THE LIII PSALM.

Dixit insipiens.

Evening
Prayer.
Ps. xiv. 1.
Ps. xiv. 2.

THE foolish body hath said in his heart : There is no God.

2 Corrupt are they, and become abominable in their wickedness : there is none that doeth good.

Ps. xiv. 3.

3 God looked down from heaven upon the children of men : to see if there were any that would understand, and seek after God.

Ps. xiv. 4.

4 But they are all gone out of the way, they are altogether become abominable : there is also none that doeth good, no not one.

Ps. xiv. 8.

5 Are not they without understanding that work wickedness : eating up my people as if they would eat bread ? they have not called upon God.

Ps. xiv. 9.
Prov. xxviii. 1.
Job xv. 20.

6 They were afraid where no fear was : for God hath broken the bones of him that besieged thee ; thou hast put them to confusion, because God hath despised them.

Ps. xiv. 11.
Rev. vi. 10.

7 Oh, that the salvation were given unto Israel out of Sion : Oh, that the Lord would deliver his people out of captivity.

8 Then should Jacob rejoice : and Israel should be right glad.

THE LIV PSALM.

Deus, in nomine.

Good Friday,
Mattins.

SAVE me, O God, for thy Name's sake : and avenge me in thy strength.

Ego autem, sicut oliva fructifera in domo Dei : speravi in misericordia Dei in æternum ; et in sæculum sæculi.

Confitebor tibi in sæculum, quia tibi Domine fecisti : et exspectabo Nomen tuum, quoniam bonum est in conspectu sanctorum tuorum.

PSALMUS LII.

DIXIT insipiens in corde suo : Non est Deus. Wed. Mattins.

Corrupti sunt, et abominabiles facti sunt in iniquitatibus : non est qui faciat bonum: in voluntatibus suis bonum non est usque ad unum

Deus de cælo prospexit super filios hominum : ut videat si est intelligens, aut requirens Deum.

Omnes declinaverunt, simul inutiles facti sunt : non est qui faciat bonum, non est usque ad unum.

Nonne scient omnes qui operantur iniquitatem : qui devorant plebem meam ut cibum panis ? cognoscent sicut escam

Deum non invocaverunt : illic trepidaverunt timore, ubi non fuit timor.

Quoniam Deus dissipavit ossa eorum qui hominibus placent : confusi sunt, quoniam Deus sprevit eos. dissipat ossa hominum sibi placentium... quia

Quis dabit ex Sion salutare Israël ? cum converterit Deus captivitatem plebis suæ : exsultabit Jacob, et lætabitur Israël. dum avertit

PSALMUS LIII.

DEUS, in Nomine tuo salvum me fac : et in virtute tua judica me. Sund. and all Festivals, Prime. Good Friday Mattins, 2nd Noct. Easter Eve, 3rd Noct. libera me

Thus also a contrast is set forth in this Psalm between the kingdom of Antichrist and the Church. The one will be rooted out of the land of the living, the other planted like a green olive-tree in the House of God. For all past mercies to her, therefore, the Church here gives thanks to God, assured that she may still hope in His Name, Who has promised that the gates of Hell shall not prevail against her.

PSALM LIII.

This Psalm is nearly identical with the fourteenth. The difference, and a very conspicuous one, is, that there is here no

mention of "the Poor" and "the Righteous," after the words "They were afraid where no fear was." This omission gives the Psalm a more direct application to the persecution of the Church by Antichrist than to the opposition offered by him to our Lord personally ; and thus it may be taken as a hymn of the Church in the last days of its militant condition, when the souls under the altar will cry, "How long, O Lord, holy and true, dost Thou not judge and avenge our blood on them that dwell on the earth ?" and when Antichrist having been empowered "to make war with the saints and to overcome them," they also will cry, "Oh, that the salvation were given unto Israel out of Sion ;

The X. Day.
Evening
Prayer.
Luke xxiii. 14.

2 Hear my prayer, O God : and hearken unto the words of my mouth.

3 For strangers are risen up against me : and tyrants, which have not God before their eyes, seek after my soul.

John xviii. 11.
xix. 11.

4 Behold, God is my helper : the Lord is with them that uphold my soul.

5 He shall reward evil unto mine enemies : destroy thou them in thy truth.

Luke xxii. 42.
xxiii. 46.

6 An offering of a free heart will I give thee, and praise thy Name, O Lord : because it is so comfortable¹.

Luke xxiii. 34.
Isa. liii. 11.

7 For he hath delivered me out of all my trouble : and mine eye hath seen his desire upon mine enemies.

THE LV PSALM.

Exaudi, Deus.

Lament. iii. 8.
Heb. v. 7.

HEAR my prayer, O God : and hide not thyself from my petition.

2 Take heed unto me, and hear me : how I mourn in my prayer, and am vexed.

3 The enemy crieth so, and the ungodly cometh on so fast : for they are minded to do me some mischief, so maliciously are they set against me.

John xi. 27.
xiii. 21.

4 My heart is disquieted within me : and the fear of death is fallen upon me.

Deus, exaudi orationem meam : auribus percipe verba oris mei.

Quoniam alieni insurrexerunt adversum me, et fortes quæsierunt animam meam : et non proposuerunt Deum ante conspectum suum.

Ecce enim Deus adjuvat me : et Dominus susceptor est animæ meæ.

Averte mala inimicis meis : et in veritate tua disperde illos.

Voluntarię sacrificabo tibi ; et confitebor nomini tuo, Domine : quoniam bonum est.

Quoniam ex omni tribulatione eripuisti me : et super inimicos meos despexit oculus meus.

PSALMUS LIV.

EXAUDI, Deus, orationem meam : et ne despexeris deprecationem meam ; intende mihi, et exaudi me. Wed. Mattins.

Contristatus sum in exercitatione mea : et conturbatus sum a voce inimici, et a tribulatione peccatoris.

Quoniam declinaverunt in me iniquitates : et in ira molesti erant mihi.

Cor meum conturbatum est in me : et formido mortis cecidit super me.

oh, that the Lord would deliver His people out of captivity." But "he that leadeth into captivity shall go into captivity ; he that killeth with the sword must be killed with the sword. Here is the patience and faith of the saints." [Rev. xiii. 10.]

PSALM LIV.

The long-established custom of the Church has given us the true meaning of this Psalm by appropriating it to the commemoration of our Blessed Lord's Passion. In the words "Save me, O God," we hear the same voice as that which uttered the bitter cry which was taken from the twenty-second Psalm. In "strangers are risen up against me," we hear the prediction, ages beforehand, of the fact that Jesus would be put to death by a foreign ruler and foreign soldiers, a circumstance in the last degree unlikely to have occurred to the uninspired mind of a Jew in David's time, but clearly foreseen and foreordained by God. In "the tyrants which have not God before their eyes," we see the unjust conduct of Pilate, who was convinced of the holy Sufferer's innocence,

¹ comfortable] i.e. strengthening. So the earliest English Bibles read Isa. xli. 7, "And he comfortide hym with nailes, that it shulde not be moued." And Phil. iv. 13, "I may alle thingis in him that comfortith me." The ultimate derivation of "comfort" is from "fortis."

and yet condemned Him through fear of men. In "God is my helper" may be traced the spirit which prompted the words, "Put up thy sword into the sheath," and "Thou couldest have no power at all against Me, except it were given thee from above." In the "offering of a free heart," we see the submission expressed in the words "not My will but Thine be done," and the voluntary yielding up of His life when no man had power to take it from Him. Lastly, the "vengeance" spoken of here receives its proper interpretation by a comparison of the last words of the Psalm with our Lord's words, "Father, forgive them, for they know not what they do." The prayer was heard, and Jesus, looking forth from His cross, "saw of the travail of His soul and was satisfied," for even His enemies were afterwards made to be at peace with Him by the power of His Intercession.

PSALM LV.

The sorrows of our Blessed Redeemer's soul are here predicted by His own inspiration, so that the prophecy becomes a history, setting forth the mental trouble which preceded His apprehension and death. This anguish culminated in the Agony of Gethsemane and the Cross, but it also pervaded all His life, and especially that period of it when His Ministry brought Him within the nearer contemplation of man's ingratitude.

The X. Day.
Evening
Prayer.
Job iv. 14.

5 Fearfulness and trembling are come upon me : and an horrible dread hath overwhelmed me.

6 And I said, O that I had wings like a dove : for then would I flee away and be at rest.

Rev. xii. 6. 14.

7 Lo, then would I get me away far off : and remain in the wilderness.

8 I would make haste to escape : because of the stormy wind and tempest.

Gen. xi. 7.
John xix. 20.
Acts ii. 4.

9 Destroy their tongues, O Lord, and divide them : for I have spied unrighteousness and strife in the city.

10 Day and night they go about within the walls thereof : mischief also and sorrow are in the midst of it.

11 Wickedness is therein : deceit and guile go not out of their streets.

John xiii. 21. 26.

12 For it is not an open enemy that hath done me this dishonour : for then I could have borne it.

13 Neither was it mine adversary that did magnify himself against me : for then peradventure I would have hid my self from him.

Luke xxii. 47.
Mark xiv. 45.
Matt. xxvi. 50.

14 But it was even thou, my companion : my guide, and mine own familiar friend.

15 We took sweet counsel together : and walked in the house of God as friends.

Matt. xxvii. 5.

16 Let death come hastily upon them, and let them go down quick into hell : for wickedness is in their dwellings, and among them.

17 As for me, I will call upon God : and the Lord shall save me.

Timor et tremor venerunt super me : et contexerunt me tenebræ.

Et dixi, quis dabit mihi pennas sicut columbæ : et volabo, et requiescam.

Ecce elongavi fugiens : et mansi in solitudine.

Exspectabam eum qui salvum me fecit : a pusillanimitate spiritus et tempestate. fueret a pusillanimo et temp.

Præcipita, Domine, divide linguas eorum : quoniam vidi iniquitatem et contradictionem in civitate.

Die ac nocte circumdabit eam super muros ejus iniquitas ; et labor in medio ejus, et injustitia.

Et non defecit de plateis ejus : usura et dolus.

Quoniam si inimicus meus maledixisset mihi : sustinuissem utique. supportassem

Et si is qui oderat me super me magna locutus fuisset : abscondissem me forsitan ab eo. absconderem me utique ab eo

Tu vero homo unanimes : dux meus et notus meus :

Qui simul mecum dulces capiebas cibus : in domo Dei ambulavimus cum consensu. cf. Matt. xxvi. 23.

Veniat mors super illos : et descendant in infernum viventes.

Quoniam nequitie in habitaculis eorum : in medio eorum. nequitia in hospitiis

Ego autem ad Deum clamavi : et Dominus salvavit me. exaudivit

That the holy Jesus suffered from the fear of death is a proof of His perfect oneness in nature with those whom He came to save. But He doubtless suffered more than the ordinary fear of death from the knowledge that He was to tread the winepress alone, and that of the people there was none with Him. [Isa. lxiii. 3.] As David went up the "ascent of the Mount of Olivet, and wept as he went," on the occasion when this Psalm was written, "the people that was with him" were also "weeping as they went up." [2 Sam. xv. 30.] But when the Son of David stedfastly set His face to go up to Jerusalem, "He went before them" [Mark x. 32], walking alone in such a manner as to show His purpose, to amaze them and make them afraid. So, when in the garden of Gethsemane, He first left the body of His Apostles at the gate, and then "went a little further," that He might be divided from the companionship even of the three chosen disciples ; and as if to make His loneliness more complete, they could not even at a distance watch *with* Him, but fell asleep.

Alone He went with those who apprehended Him, for "all forsook Him and fled ;" alone He appeared before the High Priest and Pilate, even Peter denying that he was His friend ; alone He hung upon the cross, His disciples "standing afar off." Such utter isolation in His sufferings and sorrows may have aggravated greatly the fear of death, and the horrible dread by which He was overwhelmed ; and still more would that fear be aggravated by the "storm and tempest" of the bitter and tumultuous assembly by which He was surrounded.

The twelfth and following verses contain an indication of the character of that intercourse between Christ and His Apostles, which led Him to say that He had called them friends and not servants, and that, whereas a servant knew not his master's will, they, as friends, had been admitted to take sweet counsel with Him. It was one of these whose words were smoother than oil when he said, "Master, Master, and kissed Him," and yet were as the piercing of a sword, since they were words with which he

The X. Day.
Evening
Prayer.

18 In the evening, and morning, and at noon-day will I pray, and that instantly : and he shall hear my voice.

Vespere, et mane, et meridie narabo et annuntiabo : et exaudiet vocem meam.

Luke xxii. 43.

19 It is he that hath delivered my soul in peace from the battle that was against me : for there were many with me.

Redimet in pace animam meam ab his qui appropinquant mihi : quoniam inter multos erant mecum.

20 Yea, even God, that endureth for ever, shall hear me, and bring them down : for they will not turn, nor fear God.

Exaudiet Deus, et humiliabit illos : qui est ante sæcula. Non enim est illis commutatio, et non timuerunt Deum : extendit manum suam in retribuendo.

Luke xxii. 53.

21 He laid his hands upon such as be at peace with him : and he brake his covenant.

Contaminaverunt testamentum ejus : divisi sunt ab ira vultus ejus, et appropinquavit cor illius.

Mark xiv. 45.
Prov. xii. 18.

22 The words of his mouth were softer than butter, having war in his heart : his words were smoother than oil, and yet be they very swords.

Molliti sunt sermones ejus super oleum : et ipsi sunt jacula.

1 Pet. v. 7.

23 O cast thy burden upon the Lord, and he shall nourish thee : and shall not suffer the righteous to fall for ever.

Jacta super Dominum curam tuam et ipse te enutriet : et non dabit in æternam fluctuationem justo.

24 And as for them : thou, O God, shalt bring them into the pit of destruction.

Tu vero, Deus, deduces eos : in puteum interitus.

Acts i. 25.

25 The blood-thirsty and deceitful men shall not live out half their days : nevertheless, my trust shall be in thee, O Lord.

Viri sanguinum et dolosi non dimidiabunt dies suos : ego autem sperabo in te, Domine.

THE LVI PSALM.

Miserere mei, Deus.

The XI. Day.
Morning
Prayer.

BE merciful unto me, O God, for he is daily fighting and troubling me.

PSALMUS LV.

MISERERE mei, Deus, quoniam conculcavit me homo : tota die impugnans tribulavit me.

1 Pet. v. 8.

2 Mine enemies are daily in hand to swallow me up : for they be many that fight against me, O thou most Highest.

Conculcaverunt me inimici mei tota die : quoniam multi bellantes adversum me.

3 Nevertheless, though I am sometime afraid : yet put I my trust in thee.

Ab altitudine diei timebo : ego vero in te sperabo.

betrayed that Master. It was to that one that, even at the last, the meek, loving, and forgiving Jesus said, "Friend, wherefore art thou come?"

The peculiar circumstances under which St. Peter quoted the twenty-third verse, "casting all your care upon Him, for He careth for you," show that this Psalm may be taken, also as the words of Christ's mystical body, speaking of the troubles which come upon her from Antichrist. The afflictions of the Church under Nero's persecution, foreshadowed those which will come upon her in the latter days, as is shown by our Lord's prophecy of both those periods. And, as the Jews led on the persecution of the Church whenever opportunity offered, so,

doubtless, there will be those who ought to be loving brethren, but will prove the most bitter of foes, in the terrible persecution of Antichrist. Thus, many verses of this Psalm have a future application to the position of the Church, as well as a past application to the sorrows of Christ. And they may, in a degree, be applied to all periods of trouble which fall upon the City of God, through the constant and persistent antagonism of "the Prince of this world."

PSALM LVI.

The tone of this Psalm agrees with that of the preceding : and it as clearly refers to that life-long persecution which our Lord

The XI. Day.
Morning
Prayer.
Isa. xxxi. 5.
xl. 6.

4 I will praise God, because of his word : I have put my trust in God, and will not fear what flesh can do unto me.

Luke xxiii. 2.
Matt. xxvi. 61.
xxvii. 47.

5 They daily mistake my words : all that they imagine is to do me evil.

Gen. iii. 15.

6 They hold altogether, and keep themselves close : and mark my steps, when they lay wait for my soul.

7 Shall they escape for their wickedness : thou, O God, in thy displeasure shalt cast them down.

Heb. v. 7.
Mal. iii. 16.

8 Thou tellest my flittings ; put my tears into thy bottle : are not these things noted in thy book ?

9 Whosoever I call upon thee, then shall mine enemies be put to flight : this I know ; for God is on my side.

10 In God's word will I rejoice : in the Lord's word will I comfort me.

11 Yea, in God have I put my trust : I will not be afraid what man can do unto me.

12 Unto thee, O God, will I pay my vows : unto thee will I give thanks.

13 For thou hast delivered my soul from death, and my feet from falling : that I may walk before God in the light of the living.

THE LVII PSALM.

Miserere mei, Deus.

Easter Day,
Mattins.
Ps. xvii. 8.

BE merciful unto me, O God, be merciful unto me, for my soul trusteth in thee : and under the shadow of thy wings shall be my refuge, until this tyranny be over-past.

In Deo laudabo sermones meos ; in Deo speravi : non timebo quid faciat mihi caro.

meos tota die ... sperabo
mihi homo

Tota die verba mea execrabantur : adversum me omnes cogitationes eorum in malum.

omnia consilia

Inhabitabunt et abscondent : ipsi calcaneum meum observabunt.

Sicut sustinuerunt animam meam, pro nihilo salvos facies illos : in ira populos confringes.

expectavit anima mea

Deus, vitam meam annuntiavi tibi : posuisti lachrymas meas in conspectu tuo.

Sicut et in promissione tua : tunc convertentur inimici mei retrorsum.

In quacunque die invocavero te : ecce cognovi quoniam Deus meus es.

agnovi

In Deo laudabo verbum, in Domino laudabo sermonem : in Deo speravi, non timebo quid faciat mihi homo.

sperabo

In me sunt, Deus, vota tua : quæ reddam, laudationes tibi.

vota quæ reddam laudationis

Quoniam eripuisti animam meam de morte, et pedes meos de lapsu : ut placeam coram Deo in lumine viventium.

oculos meos a lacrimis pedes

PSALMUS LVI.

MISERERE mei, Deus, miserere mei : quoniam in te confidit anima mea.

Wed. Mattins.

Et in umbra alarum tuarum sperabo : donec transeat iniquitatis.

underwent from those who lay wait for Him, who endeavoured to entangle Him in His talk, and who daily mistook His words, by imputing to Him treason against God and man. But although man was thus imagining evil against Christ, all His life was laid open before the Righteous Judge, His sorrows were noted in God's Book of remembrance, and "when He had offered up prayers and supplications, with strong crying and tears, unto Him that was able to save Him from death, He was heard in that He feared."

There is also to be found in this Psalm a direct and particular reference to the Passion of our Lord. "Man" going about to devour Him represents in one sense concrete human nature, the sins of which were the cause of all Christ's trouble ; but, in another sense, the Adversary who is ever going about seeking whom he may devour, and of whom our Lord sometimes spoke parabolically under the figure of a human Enemy. The "daily" of verses 1 and 2, should be understood as "all the day long," and

the "swallowing up" of the same verses bears also the sense of pressing down as of grapes into a wine-vat. Thus we have given to us a key to the interpretation of the Psalm as spoken of that day when our Redeemer's Body and Soul were afflicted so sorely by the sins of mankind, and bruised in the winepress of the wrath of God, that the life-giving blood might flow forth as an offering of Atonement and a fountain of health : of that day when fear bore Him down from the sixth hour to the ninth—"from the height of the day"—during the time of darkness ; when they mistook even His last cry of anguish for a cry after human succour ; when some marked His steps by sitting down and watching Him in a spirit of mere cruel curiosity, and others lay wait for His soul by saying, "Let be, let us see whether Elias will come to save Him."

So solemn a meaning of this Psalm will warn against its too close application to the troubles of our ordinary life. The member of Christ is, indeed, surrounded by spiritual enemies, the Evil

The XI. Day.
Morning
Prayer.

2 I will call unto the most high God : even unto the God that shall perform the cause which I have in hand.

3 He shall send from heaven : and save me from the reproof of him that would eat me up.

2 Tim. iv. 17.

4 God shall send forth his mercy and truth : my soul is among lions.

5 And I lie even among the children of men, that are set on fire : whose teeth are spears and arrows, and their tongue a sharp sword.

6 Set up thyself, O God, above the heavens : and thy glory above all the earth.

John xi. 48.
xviii. 39.
xix. 15.

7 They have laid a net for my feet, and pressed down my soul : they have digged a pit before me, and are fallen into the midst of it themselves.

Ps. cviii. 1.

8 My heart is fixed, O God, my heart is fixed : I will sing, and give praise.

Ps. cviii. 2.

9 Awake up, my glory ; awake, lute and harp : I my self will awake right early.

Ps. cviii. 3.

10 I will give thanks unto thee, O Lord, among the people : and I will sing unto thee among the nations.

Ps. cviii. 4.

11 For the greatness of thy mercy reacheth unto the heavens : and thy truth unto the clouds.

Ps. cviii. 5.

12 Set up thyself, O God, above the heavens : and thy glory above all the earth.

Clamabo ad Deum altissimum :
Deum qui benefecit mihi.

Misit de cœlo, et liberavit me : dedit
in opprobrium conculcantes me.

Misit Deus misericordiam suam et
veritatem suam : et eripuit animam
meam de medio catulorum leonum ;
dormivi conturbatus.

Filii hominum dentes eorum arma
et sagittæ : et lingua eorum gladius *machæra acuta*
acutus.

Exaltare super cœlos, Deus : et in
omnem terram gloria tua.

Laqueum paraverunt pedibus meis :
et incurvaverunt animam meam.

Foderunt ante faciem meam foveam :
et inciderunt in eam.

ipsi inciderunt

Paratum cor meum, Deus, paratum
cor meum : cantabo et psalmum dicam
Domino.

Exsurge gloria mea, exsurge psalte-
rium et cithara : exurgam diluculo.

Confitebor tibi in populis, Domine :
et psalmum dicam tibi in gentibus :

Quoniam magnificata est usque ad
cœlos misericordia tua : et usque ad
nubes veritas tua.

Exaltare super cœlos, Deus : et super
omnem terram gloria tua.

One and all his evil instruments, and against these the prayerful words of the Psalm may legitimately be used. But words that were primarily spoken as a prophecy relating to the persecution of Christ are infinitely too solemn to be referred to the human foes, however evil, of any other human person, however saintly.

Of the Church as a body, the whole Psalm may, however, be used without such hesitation, seeing that all foes of Christ are also enemies of His Church, and that they who persecute the Church are re-opening the wounds of the Crucified Jesus Himself. [Acts ix. 5.]

PSALM LVII.

The Easter character of this Psalm is evident in the sixth and the last five verses, the latter of which are identical with the first five verses of the 108th Psalm.

It was written by David when in the Cave of Adullam, to which there is supposed to be some reference in the appeal of the first verse to a refuge under the shadow of God's wings, and in the expression "my soul is among lions," in the fourth verse. These early verses are not less applicable to the Son of David,

however, than the latter ones, describing as they do the bitter tyranny with which He was persecuted, condemned, and tormented by those who "digged a pit before Him," and afterwards fell into the destruction which they had prepared for Him and His.

And as of David in the Cave of Adullam, and among lions in the surrounding wilderness ; as of Christ on the Cross and in the cave wherein He was buried ; so does the Psalm sing of His mystical Body taking refuge in "dens and caves of the earth," cast to the lions in the amphitheatre, smitten and slain with a tyranny to which the world never saw a parallel : and yet ever saying, "Under the shadow of Thy wings shall be my refuge, until the day-dawn come, and I awake right early."

The prophetic reference to Christ as God in the sixth and twelfth verses is strikingly plain. It is the voice of the Church calling upon Him to crown His Passion with His Resurrection, and answering His words, "I Myself will awake right early," with the chorus, "Set up Thyself, O God, above the heavens ;" "Awake up, My glory," with "Set up Thy glory above all the earth."

And as the Church has part with Christ in His sufferings, so

THE LVIII PSALM.

Si vere utique.

The XI. Day.
Morning
Prayer.

ARE your minds set upon righteousness, O ye congregation : and do ye judge the thing that is right, O ye sons of men ?

2 Yea, ye imagine mischief in your heart upon the earth : and your hands deal with wickedness.

Isa. xlvi. 8.

3 The ungodly are froward, even from their mother's womb : as soon as they are born, they go astray, and speak lies.

Rom. iii. 13.
Matt. iii. 7.
xii. 34.
Acts vii. 57.

4 They are as venomous as the poison of a serpent : even like the deaf adder that stoppeth her ears ;

Jer. viii. 17.

5 Which refuseth to hear the voice of the charmer : charm he never so wisely.

6 Break their teeth, O God, in their mouths, smite the jaw-bones of the lions, O Lord : let them fall away like water that runneth apace, and when they shoot their arrows let them be rooted out.

Ecd. vi. 3.
Job iii. 16.

7 Let them consume away like a snail, and be like the untimely fruit of a woman : and let them not see the sun.

8 Or ever your pots be made hot with thorns : so let indignation vex him, even as a thing that is raw.

Rev. xi. 17, 18.

9 The righteous shall rejoice when he seeth the vengeance : he shall wash his footsteps in the blood of the ungodly.

10 So that a man shall say, Verily there is a reward for the righteous : doubtless there is a God that judgeth the earth.

PSALMUS LVII.

SI vere utique justitiam loquimini : Wed. Mattins.
recta judicate filii hominum. justa

Etenim in corde iniquitates operamini in terra : injustitias enim manus vestræ concinnant.

Alienati sunt peccatores a vulva ;
erraverunt ab utero : locuti sunt falsa.

Furor illis secundum similitudinem *Ira*
serpentis : sicut aspidis surdæ et ob-
turantis aures suas.

Quæ non exaudiet vocem incantan-
tium : et venefici incantantis sapienter. quæ incantantur
a sapiente

Deus conteret dentes eorum in ore
ipsorum : molas leonum confringet
Dominus.

Ad nihilum devenient tanquam aqua
decurrens : intendit arcum suum donec
infirmetur.

Sicut cera quæ fluit, auferentur : *liquefacta*
supercecidit ignis, et non viderunt
solem.

Priusquam intelligerent spinæ ves- *producent*
træ rhamnum : sicut viventes, sic in
ira absorbet eos.

Lætabitur justus cum viderit vin- *vindictam im-*
dictam : manus suas lavabit in san- *piorum*
guine peccatoris.

Et dicet homo, Si utique est fructus
justo : utique est Deus judicans eos
in terra.

also in the joy and triumph of His resurrection. While therefore the Head sings, "Awake up, My glory . . . I Myself will awake right early," the prophetic echo is heard, "Thy dead men shall live, together with My dead body shall they arise. Awake and sing, ye that dwell in dust : for Thy dew is as the dew of herbs, and the earth shall cast out the dead." [Isa. xxvi. 19.]

PSALM LVIII.

David was not at any time brought before a "congregation," or assembly of judges, nor was his conduct ever debated in a judicial sense by those who gave counsel to Saul or Absalom. Our Lord was, however, brought before the Sanhedrim, the supreme assembly of judicature among the Jews, and the Psalm has a literal meaning in respect to Him which it has not in respect to David. To the unjust judgment of those who condemned Christ, and to the Jewish nation as represented by them, this Psalm must be considered to apply ; and as, in the preceding

one, the cruel severity of His foes is spoken of, so here is their cruel injustice. The comparison of these unjust judges to poisonous serpents meets with a parallel in the expression used both by St. John the Baptist and our Lord, "ye generation of vipers ;" and the reference to the deafness of the viper or adder is a prediction of the spirit in which the judges of our Lord said, "what need we any further witness ?" and in which those who stoned the first martyr of His Church, "cried out with a loud voice, and stopped their ears, and ran upon him with one accord." It was venomous hatred which prompted the foes of Christ and His Church, in both cases, and not a desire for either truth or justice.

In the latter verses of the Psalm there are some of those terrible imprecations upon which some comments are given in the notes on Psalm lxi. The explanation of the eighth verse (as it is given in the Prayer Book version) appears to be conveyed in such a paraphrase as "Though your cooking vessels can be rapidly heated by the quickly-burning thorns gathered in the wilderness,

THE LIX PSALM.

Eripe me de inimicis.

The XI. Day.
Evening
Prayer.
A Passion Psalm.
Luke xxii. 42.

DELIVER me from mine enemies,
O God : defend me from them
that rise up against me.

2 O deliver me from the wicked
doers : and save me from the blood-
thirsty men.

3 For lo, they lie waiting for my
soul : the mighty men are gathered
against me, without any offence or
fault of me, O Lord.

4 They run and prepare themselves
without my fault : arise thou therefore
to help me, and behold.

Exod. xxxii. 34.
Luke xix. 44.

5 Stand up, O Lord God of hosts,
thou God of Israel, to visit all the
heathen : and be not merciful unto
them that offend of malicious wicked-
ness.

Ps. xxii. 20.
Matt. vii. 6.
xv. 26, 27.
Rev. xxii. 15.

6 They go to and fro in the even-
ing : they grin like a dog, and run
about through the city :

7 Behold, they speak with their
mouth, and swords are in their lips :
for who doth hear ?

8 But thou, O Lord, shalt have
them in derision : and thou shalt laugh
all the heathen to scorn.

9 My strength will I ascribe unto
thee : for thou art the God of my re-
fuge.

10 God sheweth me his goodness
plenteously : and God shall let me see
my desire upon mine enemies.

Gen. iv. 14, 15.
Rev. ix. 6.
Lev. xxvi. 33.
Deut. iv. 27.
Ezek. xii. 15.

11 Slay them not, lest my people
forget it : but scatter them abroad
among the people, and put them down,
O Lord, our defence.

12 For the sin of their mouth, and
for the words of their lips they shall
be taken in their pride : and why ?
their preaching is of cursing and lies.

PSALMUS LVIII.

ERIPE me de inimicis meis, Deus
meus : et ab insurgentibus in me
libera me.

Wed. Mattins.
Good Friday,
3rd Noct.

Eripe me de operantibus iniquita-
tem : et de viris sanguinum salva me.

Quia ecce ceperunt animam meam : occupaverunt
irruerunt in me fortes.

Neque iniquitas mea, neque pecca-
tum meum, Domine : sine iniquitate
cucurri, et direxi.

et dirigebar

Exsurge in occursum meum ; et vide :
et tu, Domine, Deus virtutum, Deus
Israël.

Intende ad visitandas omnes gentes :
non miserearis omnibus qui operantur
iniquitatem.

Convertentur ad vesperam, et famem
patientur ut canes : et circuibunt civi-
tatem.

Ecce loquentur in ore suo et gladius
in labiis eorum : quoniam quis audi-
vit ?

Et tu, Domine, deridebis eos : et ad
nihilum deduces omnes gentes.

Fortitudinem meam ad te custodiam,
quia Deus susceptor meus : Deus meus,
misericordia ejus præveniet me.

Deus ostendit mihi super inimicos
meos ; ne occidas eos : nequando obli-
viscantur populi mei.

michi bona inter
occideres . . . obl.
legis tuæ

Disperge illos in virtute tua : et de-
pone eos protector meus, Domine.

Delictum oris eorum, sermonem la-
biorum ipsorum : et comprehendantur
in superbia sua.

Delicta . . . sermo

Et de execratione et mendacio : an-
nuntiabuntur in consummatione.

mendacio compe-
lantur in ira
consum.

yet the indignation of God shall more quickly overtake these unjust judges : swiftly as raw flesh could be thus sodden, more swiftly shall the fire of God's wrath destroy them."

PSALM LIX.

This Psalm has been universally interpreted as being spoken of our Lord's Passion and the destruction of the Jewish nation. It is also prophetic of the sufferings of Christ's mystical Body, and of the ultimate overthrow of Antichristian power.

In the first words we have a parallel to the historical words of our Lord, "If it be possible, let this cup pass from Me," the

human nature of Christ being made perfect in weakness, so that He might ascribe His strength unto the Divine Nature. The bloodthirstiness of the Jews was conspicuously shown in their conduct before Pilate : for when he desired to release Christ, they cried, "Crucify Him, crucify Him ;" and when Pilate washed his hands before them, they willingly accepted the responsibility thrown upon them by that act, saying, "His blood be on us and on our children." Such a thirsting for His blood on the part of His brethren was doubtless an addition to the bitterness of Christ's suffering. It is compared in this Psalm to the savage voracity of the dogs of Eastern cities, whose wild ferocity is notorious to this

The XI. Day.
Evening
Prayer.
Mark ix. 43-48.

13 Consume them in thy wrath, consume them, that they may perish : and know that it is God that ruleth in Jacob, and unto the ends of the world.

Hab. i. 8.
Zeph. iii. 3.
Rev. xiii. 7. 17.

14 And in the evening they will return : grin like a dog, and will go about the city.

15 They will run here and there for meat : and grudge if they be not satisfied.

2 Sam. xxiii. 4.
Matt. xxviii. 1.
Mark xvi. 2.
Luke xxiv. 1.
John xx. 1.

16 As for me, I will sing of thy power, and will praise thy mercy betimes in the morning : for thou hast been my defence and refuge in the day of my trouble.

Rev. xi. 17.

17 Unto thee, O my strength, will I sing : for thou, O God, art my refuge, and my merciful God.

THE LX PSALM.

Deus, repulisti nos.

Rom. xi. 1-36.

O GOD, thou hast cast us out, and scattered us abroad : thou hast also been displeased, O turn thee unto us again.

2 Thou hast moved the land, and divided it : heal the sores thereof, for it shaketh.

3 Thou hast shewed thy people heavy things : thou hast given us a drink of deadly wine.

Isa. xi. 12.
xlix. 22.
lxii. 10.

4 Thou hast given a token for such as fear thee : that they may triumph because of the truth.

In ira consummationis, et non erunt : et scient quia Deus dominabitur Jacob et finium terræ.

Convertentur ad vesperam, et famem patientur ut canes : circuibunt civitatem.

Ipsi dispergentur ad manducandum : *Ecce ipsi* si vero non fuerint saturati, et murmurabunt.

Ego autem cantabo fortitudinem *virtutem* tuam : et exaltabo mane misericordiam tuam.

Quia factus es susceptor meus : et refugium meum in die tribulationis meæ.

Adjutor meus, tibi psallam : quia Deus susceptor meus es ; Deus meus, misericordia mea.

PSALMUS LIX.

DEUS, repulisti nos, et destruxisti nos : iratus es et misertus es nobis. *Wed. Mattins.*

Commovisti terram et conturbasti eam : sana contritiones ejus ; quia commota est.

Ostendisti populo tuo dura : potasti nos vino compunctionis.

Dedisti metuentibus te significationem : ut fugiant a facie æreus.

day, and the comparison recalls the words of the prophet Zephaniah, "Her princes within her are roaring lions; her judges are evening wolves."

It is observable that this Psalm presents the unconverted Jews under the aspect of heathen, for to them as the persecutors of our Lord the words of the Psalm plainly apply. This is explained by Theodoret as a result of the change of circumstances which has taken place since their persistent and national rejection of our Lord: "The Jews, who once were the children, have, for their own wickedness, been degraded to the rank of dogs; while the Gentiles, who were once dogs, have been advanced to the dignity of sons." Nothing can, in fact, be more repugnant to Christianity than the Judaism of Christian times. The Judaism of ancient days derived all its reality from Christ, to Whom all its ordinances looked forward, and upon Whom they all depended for their efficacy. But the Judaism of Christian times rejects Christ altogether, and hence the very substance of the ancient faith, with which it professes to be one, is eliminated; and since there is none other Name under Heaven by which men must be saved, that system which rejects the Saviour is mere heathenism; or, at best, a mere empty imitation of the religion professed by Moses, David, and the prophets.

Thus the Jews have become the enemies of Christ, and of the one Church in which there is salvation. This they have ever shown themselves to be in days when they had opportunity to lead persecutions, and it is likely that the fourteenth verse of this Psalm predicts a time when they will again return, in the evening of the world's history as in the evening of our Lord's life, and devastate the City of God. When such a period arrives, the Church will look forward as Christ did; and though bowed down with the evening of trouble, look forward to a Resurrection of triumph, when she may sing her new song, praising God's mercy betimes in the morning, because He has been her refuge, and her merciful God.

PSALM LX.

As the last Psalm was a prophecy respecting the rejection of those among the ancient people of God who reject Christ, so this is the prophetic pleading of those among them who recognize the token, or banner of the Cross, which He has given for an ensign to all people, and a sign of His truth [verse 4]. As a body "Israel hath not obtained that which he seeketh for," but there were multitudes of Jews from the Apostles downward who believed in Christ, and they were "the election" who "hath obtained

The XI. Day.
Evening
Prayer.
Ps. cviii. 6.

5 Therefore were thy beloved delivered : help me with thy right hand, and hear me.

Ps. cviii. 7.

6 God hath spoken in his holiness, I will rejoice, and divide Sichem : and mete out the valley of Succoth.

Ps. cviii. 8.
Ps. cviii. 9.

7 Gilead is mine, and Manasses is mine : Ephraim also is the strength of my head ; Judah is my lawgiver,

8 Moab is my washpot ; over Edom will I cast out my shoe : Philistia, be thou glad of me.

Ps. cviii. 10.

9 Who will lead me into the strong city : who will bring me into Edom ?

Ps. cviii. 11.

10 Hast not thou cast us out, O God : wilt not thou, O God, go out with our hosts ?

Ps. cviii. 12.

11 O be thou our help in trouble : for vain is the help of man.

Ps. cviii. 13.

12 Through God will we do great acts : for it is he that shall tread down our enemies.

THE LXI PSALM.

Exaudi Deus.

Acts iv. 29.

HEAR my crying, O God : give ear unto my prayer.

Acts i. 8.

2 From the ends of the earth will I call upon thee : when my heart is in heaviness.

Matt. xvi. 18.
1 Cor. x. 4.

3 O set me up upon the rock that is higher than I : for thou hast been my hope, and a strong tower for me against the enemy.

John xiv. 2.
Rev. xxi. 3.

4 I will dwell in thy tabernacle for ever : and my trust shall be under the covering of thy wings.

Isa. liii. 11.
Rev. xxii. 5.

5 For thou, O Lord, hast heard my desires : and hast given an heritage unto those that fear thy Name.

Ut liberentur dilecti tui : salvum et . . . electi fac dextera tua, et exaudi me.

Deus locutus est in sancto suo : lætabor et partabor Sichimam ; et convallem tabernaculorum metabor.

Meus est Galaad, et meus est Manasses ; et Ephraim fortitudo capitis mei. Juda rex meus : Moab olla spei meæ.

In Idumæam extendam calceamentum meum : mihi alienigenæ subditi sunt.

Quis deducet me in civitatem munitam : quis deducet me usque in Idumæam ?

Nonne tu, Deus, qui repulisti nos : et non egredieris, Deus, in virtutibus nostris ?

Da nobis auxilium de tribulatione : quia vana salus hominibus.

In Deo faciemus virtutem : et ipse ad nihilum deducet tribulantes nos.

PSALMUS LX.

EXAUDI, Deus, deprecationem meam : intende orationi meæ. Wed. Mattins. App. and Evv. 2nd Noct.

A finibus terræ ad te clamavi, dum anxietur cor meum : in petra exaltasti me.

Deduxisti me, quia factus es spes mea : turris fortitudinis a facie inimici.

Inhabitabo in tabernaculo tuo in sæcula : protegatur in velamento alarum tuarum.

Quoniam tu, Deus meus, exaudisti orationem meam : dedisti hæreditatem timentibus Nomen tuum.

PSALM LXI.

This is the aspiration of the Church of Christ, which He has placed even in "the ends of the earth," and of which He has promised that it should be founded on the Rock of His Person, so that the gates of Hell shall not prevail against it. Thus Christ speaks in His mystical Body ; declaring (1) the perpetual dependence of the Church on her Head ; (2) the everlasting reign of Christ in and with those who have been made "kings and priests" by His redeeming love ; and (3) the never-ending work of adoration which is commenced in the day-by-day worship of the Church Militant, and perfected in the joy and praise of the Church Triumphant.

From one end of the earth to the other, then, the Church of

it." [Rom. xi. 7.] The full meaning of this Psalm will probably be brought out in a blaze of light by some great conversion of the Jews in the latter days, when they will recognize the sign of the Son of Man, and call upon Him to go forth with their hosts to the "strong city," the new Jerusalem descending out of Heaven from God. And whether or not it be God's purpose to restore His ancient people to their land, as the sixth and three following verses might be thought to intimate, they must certainly be gathered in to a blessed home if they are taken into the Church of their Redeemer.

The Psalm has an evident application to any season of trouble in the Church of God ; and is at all times a call upon Christians to look to the Cross of their Saviour as the sign of truth, and of victory over the enemies of the faith as well as over spiritual foes.

The XI. Day.
Evening
Prayer.
Luke i. 33.
Rev. i. 18.
xix. 16.
xi. 15.

6 Thou shalt grant the King a long life : that his years may endure throughout all generations.

7 He shall dwell before God for ever : O prepare thy loving mercy and faithfulness, that, they may preserve him.

Rev. xix. 1. 7.

8 So will I always sing praise unto thy Name : that I may daily perform my vows.

THE LXII PSALM.

Nonne Deo?

The XII. Day.
Morning
Prayer.

MY soul truly waiteth still upon God : for of him cometh my salvation.

2 Cor. iv. 9. 18.

2 He verily is my strength and my salvation : he is my defence, so that I shall not greatly fall.

Isa. xxx. 13.
Ezek. xliii. 11.

3 How long will ye imagine mischief against every man : ye shall be slain all the sort of you ; yea, as a tottering wall shall ye be, and like a broken hedge.

Ezek. xliii. 10.

4 Their device is only how to put him out whom God will exalt : their delight is in lies, they give good words with their mouth, but curse with their heart.

5 Nevertheless, my soul, wait thou still upon God : for my hope is in him.

Matt. x. 22.

6 He truly is my strength and my salvation : he is my defence, so that I shall not fall.

Matt. xvi. 18.

7 In God is my health, and my glory : the rock of my might, and in God is my trust.

1 Sam. i. 15.

8 O put your trust in him always, ye people : pour out your hearts before him, for God is our hope.

Dies super dies regis adjicies : annos ejus usque in diem generationis et generationis.

Permanet in æternum in conspectu Dei : misericordiam et veritatem ejus quis requiret?

Sic psalmum dicam Nomini tuo in sæculum sæculi : ut reddam vota mea de die in diem.

PSALMUS LXI.

NONNE Deo subjeeta erit anima mea? ab ipso enim salutare meum.

Nam et ipse Deus meus et salutaris meus : susceptor meus non movebor amplius.

Quousque irrucitis in hominem : interficitis universi vos, tanquam parieti inclinato et maceræ depulsæ?

Veruntamen pretium meum cogitaverunt repellere : cucurri in siti ; ore suo benedicebant, et corde suo maledicebant.

Veruntamen Deo subjecta esto anima mea : quoniam ab ipso patientia mea.

Quia ipse Deus meus et salvator meus : adjutor meus ; non emigrabo.

In Deo salutare meum, et gloria mea : Deus auxilii mei ; et spes mea in Deo est.

Sperate in eo omnis congregatio populi : effundite coram illo corda vestra ; Deus adjutor noster in æternum.

Christ is beseeching Him to draw closer that union with Himself which is here spoken of as a setting up upon the Rock. She is pleading the merit of His Intercession Whose desires have been heard, and Who, looking forth on the heritage gained by the travail of His soul, was satisfied. Knowing His prayer, "That they all may be one ; as Thou, Father, art in Me, and I in Thee, that they also may be one in us" [John xvii. 21], she knows that He Who was dead and is alive again, Who is King of kings and Lord of lords, and Who will reign for ever and ever, will prepare His loving mercy and faithfulness for the preservation of His mystical Body, and that the "crying" of her prayers here will end in the eternity of her praises hereafter.

PSALM LXII.

The exclamation of strong faith in the second and seventh verses of this Psalm connects it with the preceding one, in which

"O set me up upon the Rock that is higher than I," is the characteristic aspiration. It is the faith of Christ's mystical Body while in a state of outward depression : "We are troubled on every side, yet not distressed ; we are perplexed, but not in despair ; persecuted, but not forsaken ; cast down, but not destroyed . . . while we look not at the things which are seen, but at the things which are not seen : for the things which are seen are temporal, but the things which are not seen are eternal."

The third verse seems to associate itself very naturally with the passages of Isaiah and Ezekiel noted in the margin ; and especially with the latter of them, in which the prophets who seduced the people from their true allegiance to God are said to build up a wall, and temper it with untempered mortar only, to see it utterly destroyed. For the device of those who "imagine mischief" is plainly against Christ's dignity : it is "only to put Him out Whom God will exalt," to depreciate the glory of our

The XII. Day.
Morning
Prayer. 9 As for the children of men, they are but vanity : the children of men are deceitful upon the weights, they are altogether lighter than vanity itself.

Ezek. xlii. 8.
Rev. xiii. 14. 10 O trust not in wrong and robbery, give not yourselves unto vanity : if riches increase, set not your heart upon them.

John v. 22. 27.
Rev. xix. 1. 11 God spake once, and twice I have also heard the same : that power belongeth unto God ;

2 Cor. v. 10.
1 Cor. iii. 8. 12 And that thou, Lord, art merciful : for thou rewardest every man according to his work.

THE LXIII PSALM.

Deus, Deus meus.

Matt. xxvii. 46. O GOD, thou art my God : early will I seek thee.

John xix. 28. 2 My soul thirsteth for thee, my flesh also longeth after thee : in a barren and dry land where no water is.

3 Thus have I looked for thee in holiness : that I might behold thy power and glory.

4 For thy loving kindness is better than the life itself : my lips shall praise thee.

Heb. vii. 25.
1 Tim. ii. 8. 5 As long as I live will I magnify thee on this manner : and lift up my hands in thy Name.

6 My soul shall be satisfied even as it were with marrow and fatness : when my mouth praiseth thee with joyful lips.

7 Have I not remembered thee in my bed : and thought upon thee when I was waking ?

8 Because thou hast been my helper : therefore under the shadow of thy wings will I rejoice.

9 My soul hangeth upon thee : thy right hand hath upholden me.

Veruntamen vani filii hominum, mendaces filii hominum in stateris : ut decipiant ipsi de vanitate in idipsum.

Nolite sperare in iniquitate, et rapinas nolite concupiscere : divitiæ si affluent, nolite cor apponere.

Semel locutus est Deus, duo hæc audiui ; quia potestas Dei est, et tibi, Domine, misericordia : quia tu reddes unicuique juxta opera sua.

singulis secundum

PSALMUS LXII.

DEUS, Deus meus : ad te de luce vigilo.

Lauds, ferial and festival. Lauds of the departed.

Sitivit in te anima mea : quam multiplieiter tibi caro mea.

In terra deserta, invia, et inaquosa ; sic in sancto apparui tibi : ut viderem virtutem tuam, et gloriam tuam.

In deserto, et in invia et in inaquoso

Quoniam melior est misericordia tua super vitas : labia mea laudabunt te.

vitam

Sic benedicam te in vita mea : et in nomine tuo levabo manus meas.

Sicut adipe et pinguedine repleatur anima mea : et labiis exsultationis laudabit os meum.

labia exsultationis laudabunt nomen tuum

Sic memor fui tui super stratum meum ; in matutinis meditabor in te : quia fuisti adjutor meus.

factus es

Et in velamento alarum tuarum exsultabo ; adhæsit anima mea post te : me suscepit dextera tua.

Lord as Incarnate God, and to deny the sovereign exaltation to which He has been raised.

From these two associations we may very properly consider this Psalm as referring to all those developments of unbelief in our Blessed Lord which will reach their climax in the final persecution of Him, in His Church, by Antichrist.

PSALM LXIII.

Our Lord's words upon the cross are recalled by the opening explanation of this Psalm, "O God, Thou art my God," and His cry "I thirst," by the second verse. St. Augustine also remembers,

when commenting upon the eleventh verse, that our Lord said of Herod, "Go tell that fox," and as Herod was an Edomite and not a Jew, he conjectures that the imprecation of that verse was fulfilled by the Jews falling under the dominion of foreign rulers : "they rejected the Lamb, they chose the fox." This idea seems to be confirmed by the immediate reference to "the King" which follows ; for, in the Psalms, the King spoken of is ever, mystically, the King of kings, and Lord of lords. Thus light is thrown on several parts of this Psalm as applying to our Lord. "Early will I seek Thee," recalls to mind that "very early in the morning" when the sepulchre was found empty by the holy women,

The XII Day.
Morning
Prayer.

10 These also, that seek the hurt of my soul : they shall go under the earth.

11 Let them fall upon the edge of the sword : that they may be a portion for foxes.

12 But the King shall rejoice in God ; all they also that swear by him shall be commended : for the mouth of them that speak lies shall be stopped.

Luke xiii. 32.

2 Tim. ii. 19.
Rev. xiii. 5.
2 Thess. ii. 8.

THE LXIV PSALM.

Exaudi, Deus.

HEAR my voice, O God, in my prayer : preserve my life from fear of the enemy.

Gen. xlix. 6.
Jer. xv. 17.

2 Hide me from the gathering together of the froward : and from the insurrection of wicked doers ;

John xx. 12, 15.
Luke xxiii. 10.
21.

3 Who have whet their tongues like a sword : and shoot out their arrows, even bitter words ;

4 That they may privily shoot at him that is perfect : suddenly do they hit him, and fear not.

John xii. 46—57.

5 They encourage themselves in mischief : and commune among themselves, how they may lay snares, and say, that no man shall see them.

Rev. xvii. 13, 14.

6 They imagine wickedness, and practise it : that they keep secret among themselves, every man in the deep of his heart.

Deut. xxxii. 23.
Rev. xviii. 8.

7 But God shall suddenly shoot at them with a swift arrow : that they shall be wounded.

8 Yea, their own tongues shall make them fall : insomuch that whoso seeth them shall laugh them to scorn.

Ipsi vero in vanum quæsierunt animam meam ; introibunt in inferiora terræ : tradentur in manus gladii ; partes vulpium erunt.

Rex vero lætabitur in Deo ; laudabuntur omnes qui jurant in eo : quia obstructum est os loquentium iniqua.

PSALMUS LXIII.

EXAUDI, Deus, orationem meam cum deprecor : a timore inimici eripe animam meam.

Wed. Mattins.
App. and Evng.
2nd Noct.
tribulor

Protexisti me a conventu malignantium : a multitudine operantium iniquitatem.

Quia exacerunt ut gladium linguas suas : intenderunt arcum rem amaram, ut sagittent in occultis immaculatum.

Subito sagittabunt eum, et non timebunt : firmaverunt sibi sermonem nequam.

Narraverunt ut absconderent laqueos : dixerunt, Quis videbit eos ?

Disputaverunt

Scrutati sunt iniquitates : defecerunt scrutantes scrutinio.

Accedet homo ad eor altum : et exaltabitur Deus.

Sagittæ parvulorum factæ sunt plagæ eorum : et infirmatæ sunt contra eos linguæ eorum.

et pro nihilo habuerunt contra

Conturbati sunt omnes qui videbant eos : et timuit omnis homo.

because Christ had arisen to seek His Father : "they also that swear by Him" are they who "name the Name of Christ," and have "this seal, The Lord knoweth them that are His," the mystic Tau, or Cross, of Ezekiel [Ezek. ix. 4], the "seal of the living God," with which "the servants of our God are sealed in their foreheads" [Rev. vii. 2].

Thus also we may judge that "them that speak lies" is to be interpreted in no ordinary sense, but of that Antichrist unto whom was given a "mouth speaking great things and blasphemies," whose "mark" also will be received "in their right hand, or in their foreheads," by those who are deceived by him, but whom the Lord shall "consume with the spirit of His mouth, and shall destroy with the brightness of His Coming."

PSALM LXIV.

The tone of this Psalm clearly identifies it with Christ and His enemies ; and, by a more remote anticipation, with the Church of God, and the simulative Church which Antichrist will establish in the last days.

As a prophetic hymn sung in the person of Christ, He is heard

praying in it that He may be preserved from the malice of the Sanhedrim and of the general assembly of the Jewish multitude : who were devising secret plots, and making tumultuous insurrection against "Him that is perfect," whose immaculacy was openly acknowledged by the chief judge and governor of the nation ; and more privately by their own subordination of false witnesses. But the arrow of God's justice sped more swiftly and surely against them than their own arrows against Christ ; and their own tongues, their "bitter words," were one cause of their fall. They said, "We have no king but Cæsar," and Cæsar avenged their rebellion against him by destroying their Temple, city, and nation. They said, "His blood be upon us and on our children," and their words were fulfilled by an avenging of that holy blood which has lasted from that day for more than eighteen centuries ; an avenging so clearly the work of a Divine Ruler that all men who see into the inner meaning of great events and courses of events say, "This hath God done," perceiving "that it is His work." So have the Jews fallen, that their degeneracy has made that nation an object of just scorn, which was anciently the most noble nation on the face of the earth. But THE REIGN-

The XII. Day.
Morning Prayer.
Rev. xviii. 10. 20.
Exod. viii. 19.
Rev. xix. 1. 15.

9 And all men that see it shall say,
This hath God done : for they shall perceive that it is his work.

10 The righteous shall rejoice in the Lord, and put his trust in him : and all they that are true of heart shall be glad.

THE LXV PSALM.

Te decet hymnus.

Evening Prayer.
THOU, O God, art praised in Sion : and unto thee shall the vow be performed in Jerusalem.

2 Thou that hearest the prayer : unto thee shall all flesh come.

Rom. vii. 18. 24.
3 My misdeeds prevail against me : O be thou merciful unto our sins.

Rom. vii. 25.
John xiv. 3.
Rev. xxii. 4.
4 Blessed is the man, whom thou choosest, and receivest unto thee : he shall dwell in thy court, and shall be satisfied with the pleasures of thy house, even of thy holy temple.

Isa. xi. 4—16.
John v. 25.
Rev. xx. 13.
v. 13.
5 Thou shalt shew us wonderful things in thy righteousness, O God of our salvation : thou that art the hope of all the ends of the earth, and of them that remain in the broad sea.

6 Who in his strength setteth fast the mountains : and is girded about with power.

Matt. viii. 26.
Rev. xxi. 1.
7 Who stilleth the raging of the sea : and the noise of his waves, and the madness of the people.

Rev. i. 8.
Job xxxviii. 7.
Rev. xxii. 3.
8 They also that dwell in the uttermost parts of the earth shall be afraid at thy tokens : thou that makest the outgoings of the morning and evening to praise thee.

Et annuntiaverunt opera Dei : et facta ejus intellexerunt.

Lætabitur justus in Domino et sperabit in eo : et laudabuntur omnes recti corde.

PSALMUS LXIV.

TE decet hymnus, Deus, in Sion : et tibi reddetur votum in Hierusalem. Wed. Mattins. Lauds of the departed.

Exaudi orationem meam : ad te omnis caro veniet.

Verba iniquorum prævaluerunt super nos : et impietatibus nostris tu propitiaberis.

Beatus quem elegisti, et assumpisti : inhabitabit in atrijs tuis. tabernaculis

Replebimur in bonis domus tuæ : sanctum est templum tuum, mirabile in æquitate.

Exaudi nos, Deus salutaris noster : spes omnium finium terræ, et in mari longe.

Præparans montes in virtute tua, accinctus potentia : qui conturbas profundum maris, sonum fluctuum ejus. auc. ejus quis sustinuit.

Turbabuntur gentes, et timebunt qui habitant terminos a signis tuis : exitus matutini et vespere delectabis. omnes qui habitant fines delectaveris

ous rejoices in the Lord in the new Israel, whom He has made "true of heart" by the new heart with which He has endowed the regenerate.

Against the future gathering together of the froward under the rule of Antichrist the spouse of Christ will prevail as He Himself prevailed, and, like Him, after a period of suffering. Then again will the Hand of an Almighty Judge make itself evident to all, so that it shall be said of the mystical Babylon, "Rejoice over her, thou Heaven, and ye holy Apostles and Prophets ; for God hath avenged you on her." . . . "True and righteous are His judgments."

PSALM LXV.

The doctrine of the Holy Trinity was revealed in Old Testament prophecies in such language that the coming of Christ and the Holy Ghost could alone give the key to its meaning. This and the two following Psalms the Christian may thus use as hymns to the praise of God the Creator, God the Redeemer, and

God the Sanctifier, when the Jew could see in them only the praise of God as He revealed Himself on Sinai.

But the Three Persons of the Blessed Trinity are so intimately united that no human thought can safely dwell upon their individuality, and consequently these three Psalms run into each other, mingling the praises of the whole Trinity with those of each Person. So also, as God's kingdom of Nature and His kingdom of Grace are separate, and yet closely united, the Psalm in praise of God as the Creator of the visible world of nature, looks, all through, to the "things which are not seen," magnifying His glory in the "new Heavens and the new Earth" which have been founded in the redeeming work of Christ.

The second, third, and fourth verses of this Psalm are to be interpreted in the spirit of St. Paul's words, that "we must all appear before the judgment-seat of Christ," and "who shall deliver me from the body of this death ? I thank God through Jesus Christ our Lord." As the continual intercession of our Mediator is being heard always by God, so also is "the prayer"

The XII. Day.
Evening
Prayer.

Ezek. xlvii. 9.
John iv. 13, 14.
Rev. xxii. 1.
John vi. 35.
xii. 24.

9 Thou visitest the earth, and bless-
est it : thou makest it very plenteous.

10 The river of God is full of water :
thou preparest their corn, for so thou
providest for the earth.

11 Thou waterest her furrows, thou
sendest rain into the little valleys
thereof : thou makest it soft with
the drops of rain, and blessest the
increase of it.

John vi. 51.
Rev. xxii. 2.

12 Thou crownest the year with
thy goodness : and thy clouds drop
fatness.

Isa. xviii. 4.
Hos. xiv. 5.

13 They shall drop upon the dwell-
ings of the wilderness : and the little
hills shall rejoice on every side.

John x. 16.
Matt. xxv. 31.
Joel iii. 13.*
Matt. xiii. 39.
Rev. xiv. 15. 18.

14 The folds shall be full of sheep :
the valleys also shall stand so thick
with corn, that they shall laugh and
sing.

THE LXVI PSALM.

Jubilate Deo.

Isa. xlii. 8.
Jer. xliii. 16.

O BE joyful in God, all ye lands :
sing praises unto the honour of
his Name, make his praise to be glo-
rious.

Acts ii. 11.
Rev. xv. 3.

2 Say unto God, O how wonderful
art thou in thy works : through the
greatness of thy power shall thine
enemies be found liars unto thee.

Isa. lx. 3.
Rev. vii. 9.

3 For all the world shall worship
thee : sing of thee, and praise thy
Name.

Visitasti terram et inebriasti eam :
multiplicasti locupletare eam.

Flumen Dei repletum est aquis :
parasti cibum illorum ; quoniam ita
est præparatio ejus.

Rivos ejus inebrians, multiplica ge-
nimina ejus : in stillicidiis ejus læta-
bitur germinans. multiplicans gene-
rationes ejus
lætabitur dum
exoriatur

Benedices coronæ anni benignitatis
tuæ : et campi tui replebuntur uber-
tate. Benedicens coro-
nam

Pinguescent speciosa deserti : et
exultatione colles accingentur. fines deserti

Induti sunt arietes ovium, et valles
abundabunt frumento : clamabunt ;
etenim hymnum dicent.

PSALMUS LXV.

JUBILATE Deo omnis terra, Wed. Mattins.
Epiphany,
1st Noct.
psalmum dicite Nomini ejus : date
gloriam laudi ejus.

Dicite Deo, Quam terribilia sunt
opera tua, Domine : in multitudine vir-
tutis tuæ mentientur tibi inimici tui.

Omnis terra adoret te, et psallat
tibi : psalmum dicat Nomini tuo. tuo Altissime

of His Church, "Thy kingdom come;" and in answer to it "all flesh shall come" unto Him. In that day who will be able to say otherwise than "my misdeeds prevail against me, O be Thou merciful unto our sins?" And, on the other hand, how vast "a multitude, which no man can number," will be able to claim a share in the saving words of Christ, "Behold, I and the children whom Thou hast given Me," and to say, "Blessed is THE MAN Whom Thou choosest and receivest unto Thee." Blessed all they who in that day are still part of His mystical Body : "they shall see His face, and His Name shall be in their foreheads."

The remainder of the Psalm is so full of suggestive thoughts in reference to the work of grace in the Church Militant, and that of salvation in the Church Triumphant, that it is impossible to draw out its Christian application thoroughly in a few lines. Some such thoughts are indicated by the marginal references : and the key to the whole Psalm may be found in the song with which the four-and-twenty elders worship the Creator, proclaiming His glory as revealed in the fourfold Gospel :—"Thou art worthy, O Lord, to receive glory and honour and power : for Thou hast created all things, and for Thy pleasure they are and were created." [Rev. iv. 11.] Thou hast set fast the mountains of the earth, and the Rock of Thy Church : Thou art girded about with the power of the Godhead and of the Manhood : Thou didst still the raging of the Deluge, and Thou hast bidden the winds

and the waves to "be still" around Thy saving Ark : Thee the Sons of God praised in the morning of Creation, Thee all the redeemed praise in the evening of redemption and salvation : Thou hast visited the earth with natural abundance, and with the abundance of the river of Life and the Bread of Heaven : Thou crownest year by year with Thy goodness, and Thy goodness shall be our song when Thou dost crown the whole period of redemption with Thy good salvation. And in that day, O Lord, shall Thy folds be full of Thy sheep, and Thy garner rejoicing in the harvest of that "Corn of wheat" which abideth not alone.

PSALM LXVI.

In the Septuagint version the title affixed to this Psalm is, "For the end, a Song of a Psalm of Resurrection," which shows that the Church has for many ages, and perhaps even before the time of the Incarnation, considered it to be especially associated with Him Who is now revealed to us as the second Person in the Blessed Trinity. As the general strain of the preceding Psalm associated the works of Creation with those of Grace, so that of this Psalm associates with the latter the wonderful doings of God's Providence toward the children of men : the contemplation of those doings centring upon His dealings with the ancient and the new Israel. The song is thus sung of the Resurrection of Christ's

The XII. Day.
Evening
Prayer.

4 O come hither, and behold the works of God : how wonderful he is in his doing toward the children of men.

Exod. xiv. 22.
Isa. xl. 15.
Zech. x. 11.
Rev. xxi. 1.

5 He turned the sea into dry land : so that they went through the water on foot ; there did we rejoice thereof.

6 He ruleth with his power for ever ; his eyes behold the people : and such as will not believe shall not be able to exalt themselves.

Rev. xix. 5.

7 O praise our God, ye people : and make the voice of his praise to be heard ;

8 Who holdeth our soul in life : and suffereth not our feet to slip.

Isa. i. 25.
xlviii. 10.
Zech. xiii. 9.
1 Pet. i. 7.
Mal. iii. 3.

9 For thou, O God, hast proved us : thou also hast tried us, like as silver is tried.

10 Thou broughtest us into the snare : and laidest trouble upon our loins.

Isa. li. 23.
xliv. 2.

11 Thou sufferedst men to ride over our heads : we went through fire and water, and thou broughtest us out into a wealthy place.

12 I will go into thine house with burnt-offerings : and will pay thee my vows, which I promised with my lips, and spake with my mouth, when I was in trouble.

13 I will offer unto thee fat burnt-sacrifices, with the incense of rams : I will offer bullocks and goats.

Phil. iii. 8-11.

14 O come hither, and hearken, all ye that fear God : and I will tell you what he hath done for my soul.

15 I called unto him with my mouth : and gave him praises with my tongue.

Venite et videte opera Dei : terribilis in consiliis super filios hominum. *quam terribilis*

Qui convertit mare in aridam ; in flumine pertransibunt pede : ibi læta bimur in ipso. *pertransiit*

Qui dominatur in virtute sua in æternum ; oculi ejus super gentes respiciunt : qui exasperant non exaltentur in semetipsis. *in ira provocant*

Benedicite gentes Deum nostrum : et auditam facite vocem laudis ejus. *et obaudite vocem*

Qui posuit animam meam ad vitam : et non dedit in commotionem pedes meos. *commoveri*

Quoniam probasti nos, Deus : igne nos examinasti, sicut examinatur argentum.

Induxisti nos in laqueum, posuisti tribulationes in dorso nostro : imposuisti homines super capita nostra.

Transivimus per ignem et aquam : et eduxisti nos in refrigerium.

Introibo in domum tuam in holocaustis : reddam tibi vota mea quæ distinxerunt labia mea.

Et locutum est os meum : in tribulatione mea.

Holocausta medullata offeram tibi cum incenso arietum : offeram tibi boves cum hircis. *incensu et arietibus*

Venite, audite, et narrabo, omnes qui timetis Deum : quanta fecit animæ meæ.

Ad ipsum ore meo clamavi : et exaltavi sub lingua mea. *Ab ipso ore meo*

mystical Body rather than respecting that of His natural Body : and it may be observed that the expressions used in the opening verses are of the most comprehensive character : "all ye lands," "all the world," distinctly prophesying the universal spread of Christ's Kingdom.

The first words of those who were converted out of "all lands" on the Day of Pentecost show the fulfilment of the first words of this Psalm :—"We do hear them speak in our tongues the wonderful works of God : and among the earliest of the songs of the redeemed is named the "song of Moses and the Lamb :"—"Great and marvellous are Thy works, Lord God Almighty ; just and true are Thy ways, Thou King of Saints. Who shall not fear Thee, O Lord, and glorify Thy Name ? for Thou only art holy : for all nations shall come and worship before Thee ; for Thy judgments are made manifest." In the same strain the Church of Christ is ever pointing to the mercies of God in creating, redeeming, and sanctifying mankind and invites all to come and join their voices

in His praise. He led His ancient people through the sea as on dry land ; and so He has ever preserved His new Israel from being overwhelmed by the sea of the world ; but has turned the sea into dry land by making the kingdoms of this world the kingdoms of the Lord and of His Christ. Hereafter He will so order it that there shall be an opposing world no longer, but only His Church ;—"there shall be no more sea."

The nation of the Jews passed through much affliction, which the prophecies tell us was sent partly for their punishment, and partly for their purification. The latter was never so effectually accomplished as to fulfil entirely the words and spirit in which the whole Psalm, from the seventh verse to the end, is written. We must, therefore, look for a more complete fulfilment of it in God's trial of the Church by some great "fight of affliction," such as our Lord predicts will happen in the end of the world [Matt. xxiii. 4-31]. At that time, the prophet Malachi tells us, the Lord "shall sit as a refiner and purifier of silver ; and He shall

The XII. Day.
Evening
Prayer.
Isa. i. 15.
John ix. 31.

16 If I incline unto wickedness with mine heart : the Lord will not hear me.

17 But God hath heard me : and considered the voice of my prayer.

Rev. vii. 14. 18 Praised be God who hath not cast out my prayer : nor turned his mercy from me.

THE LXVII. PSALM.

Deus misereatur.

Evensong Canticle.
Holy Matrimony.
John i. 4.
Isa. lx. 1.

GOD be merciful unto us, and bless us : and shew us the light of his countenance, and be merciful unto us ;

Isa. xxxvii. 15—
20.
Luke ii. 30.

2 That thy way may be known upon earth : thy saving health among all nations.

3 Let the people praise thee, O God : yea, let all the people praise thee.

Isa. lx. 3.
ix. 7.

4 O let the nations rejoice and be glad : for thou shalt judge the folk righteously, and govern the nations upon earth.

5 Let the people praise thee, O God : let all the people praise thee.

Isa. xlv. 8.
Ezek. xxxiv. 27.

6 Then shall the earth bring forth her increase : and God, even our own God, shall give us his blessing.

Isa. lx. 20.
Zech. viii. 12, 13.

7 God shall bless us : and all the ends of the world shall fear him.

THE LXVIII PSALM.

Exsurgat Deus.

The XIII. Day.
Morning
Prayer.
Whitsunday
Mattins.
Numb. x. 35.

LET God arise, and let his enemies be scattered : let them also that hate him flee before him.

Iniquitatem si aspexi in corde meo : *conspexit* non exaudiet Dominus.

Propterea exaudivit Deus : et attendit *intendit* voci deprecationis mee.

Benedictus Deus, qui non audivit deprecationem meam : et misericordiam suam a me.

PSALMUS LXVI.

DEUS misereatur nostri, et benedicat nobis : illuminet vultum suum super nos, et misereatur nostri. Sund. and Fest. Lauds. Lauds of the departed.

Ut cognoscamus in terra viam tuam : in omnibus gentibus salutare tuum.

Confiteantur tibi populi, Deus : confiteantur tibi populi omnes.

Lætentur et exsultent gentes, quoniam judicas populos in æquitate : et gentes in terra dirigis.

Confiteantur tibi populi, Deus, confiteantur tibi populi omnes : terra dedit fructum suum.

Benedicat nos Deus, Deus noster ; benedicat nos Deus : et metuant eum omnes fines terræ.

PSALMUS LXVII.

EXSURGAT Deus, et dissipentur inimici ejus : et fugiant qui oderunt eum a facie ejus. Wed. Whitsuntide, Mattins.

purify the sons of Levi, and purge them as gold and silver, that they may offer unto the Lord an offering in righteousness." And speaking of the palm-bearers thus refined, the angel told St. John, "These are they which came out of great tribulation, and have washed their robes, and made them white in the blood of the Lamb." [Rev. vii. 14.]

PSALM LXVII.

It has been pointed out at page 35, that there is some similarity between the Song of Simeon and this Psalm. Perhaps the Gospel Canticle was suggested by the well-known words of the Psalm, as the Magnificat appears to have been suggested by the Song of Hannah : but, whether it were so or not, the Psalm is clearly to be understood only by taking it as a prophecy of the spread of the Gospel, the illumination of mankind by that Light of the world Who alone can make God's way truly known upon earth.

Hence this Psalm is to be interpreted as a hymn to God the Holy Ghost. He was merciful to mankind by blessing it with

the Incarnation of our Lord, and thus causing to shine on earth the WORD, "the true Light, which, coming into the world, lighteth every man." [John i. 9.] He blessed mankind by spreading the knowledge of His saving health among all nations, when He gave the Apostles those marvellous gifts by which they were enabled to convert the world. He causes the earth to bring forth her spiritual increase by bestowing on the Ministry of the Church those ordinary gifts which enable them to give sacramental life and nourishment. "Neither is he that planteth any thing, nor he that watereth ; but God that giveth the increase." [1 Cor. iii. 7.]

The jubilant tone of this prophetic hymn may encourage us to hope that, notwithstanding the dreadful position in which the Jews stand towards the one only Saviour, whom they wilfully and blindly deny, the time will come when "a remnant according to the election of grace" [Rom. xi. 5] will again be found as in the first days of Christianity, and when the prophecy in Zech. viii. 13 will be again fulfilled : "So will I save you, and ye shall be a blessing."

The XIII. Day. • 2 Like as the smoke vanisheth, so shalt thou drive them away : and like as the wax melteth at the fire, so let the ungodly perish at the presence of God.

Morning Prayer.
Judg. v. 31.
Mal. iii. 2.

3 But let the righteous be glad and rejoice before God : let them also be merry and joyful.

Isa. xl. 3.
xii. 2.

4 O sing unto God, and sing praises unto his Name : magnify him that rideth upon the heavens, as it were upon an horse; praise him in his Name, yea, and rejoice before him.

Bible Version, in his Name JAH¹.

5 He is a Father of the fatherless, and defendeth the cause of the widows : even God in his holy habitation.

6 He is the God that maketh men to be of one mind in an house, and bringeth the prisoners out of captivity : but letteth the runagates continue in scarceness.

Isa. xl. 10.

7 O God, when thou wentest forth before the people : when thou wentest through the wilderness,

Judg. v. 4, 5.
Exod. xix. 18.
Heb. xii. 18.
Matt. xxviii. 2.
Acts ii. 2. iv. 31.
Heb. xii. 22.

8 The earth shook, and the heavens dropped at the presence of God : even as Sinai also was moved at the presence of God, who is the God of Israel.

Ps. lxxii. 6.
Hos. xiv. 5.
Ezek. xxxiv. 26.

9 Thou, O God, sentest a gracious rain upon thine inheritance : and refreshedst it when it was weary.

10 Thy congregation shall dwell therein : for thou, O God, hast of thy goodness prepared for the poor.

Sicut deficit fumus, deficiant; sicut fluit cera a facie ignis, sic pereant peccatores a facie Dei.

Et justi epulentur, et exsultent in conspectu Dei: et delectentur in lætitiis.

Cantate Deo, psalmum dicite Nomini ejus: iter facite ei qui ascendit super occasum; Dominus Nomen illi.

Exsultate in conspectu ejus: turbabuntur a facie ejus, patris orphanorum, et judicis viduarum.

Deus in loco sancto suo: Deus qui inhabitare facit unius moris in domo.

Qui educit vinetos in fortitudine: similiter eos qui exasperant, qui habitant in sepulchris.

Deus, cum egredereris in conspectu populi tui: cum pertransires in deserto;

Terra mota est; etenim coeli distilaverunt a facie Dei Sinai: a facie Dei Israel.

Pluviam voluntariam segregabis, Deus, hereditati tuæ; et infirmata est: tu vero perfecisti eam.

Animalia tua habitabunt in ea: parasti in dulcedine tua pauperi, Deus.

PSALM LXXVIII.

The whole Western Church has used this Psalm on Whitsunday time immemorial, and in the ancient Church of England it was also used every morning during the Octave. It is thus interpreted

¹ This is a form of the holy Name "JEHOVAH," and is found in the song of Moses [Exod. xv. 2], where the authorized version translates it "the LORD." It is the termination of the familiar word Hallelu-jah of Rev. xix. 4, 6, and of the Psalms, a word which forms an integral part of the praises of the Jewish economy, the Christian Church, and of glorified saints in Heaven.

This sacred word was not introduced into the authorized version until A.D. 1611, although it is found in the Geneva Bible. It had not, therefore, of course, any place in the Great Bible of 1540, from which the Prayer-book Psalms are taken. The earliest Prayer Book in which it has been discovered is an Oxford octavo of Baskett, dated 1716, but it was not commonly printed until the middle of the last century. Yet in the Scottish Book of 1637 it had already appeared.

In an English Psalter of 1540 [Douce BB. 71, Bodl. Lib.] the latter half of the verse is rendered as in the Vulgate, "Take your journey to Him that ascendeth up above the west, the Lord is His Name;" but in Matthew's Bible of 1537 it is the same as in the Great Bible of 1540. It seems difficult to believe that some confusion has not arisen in our English version through the identity of the German word "jah" and the English word "yea." The sacred Name is undoubtedly in the Hebrew, but the Septuagint is identical with the Vulgate: and it seems preferable to use the form of the verse adopted in the Seal'd Books, as above, rather than to sing the Ineffable Name itself, for which "the LORD" is reverently substituted in the English Bible.

as a hymn of praise to God the Holy Ghost, commemorating His work in the Church of God, and setting forth the typical relation to that work of God's dealings with His ancient congregation.

The whole Psalm conveys the idea of a triumphant, irresistible march: the forward march of the Church of Christ, according to the words of the prophet,—“I will surely assemble, O Jacob, all of thee; I will surely gather the remnant of Israel; I will put them together as the sheep of Bozrah, as the flock in the midst of their fold: they shall make great noise by reason of the multitude of men. The Breaker is come up before them; they have broken up, and have passed through the gate, and are gone out by it: and their King shall pass before them, and the Lord on the head of them.” [Micah ii. 13.] It seems to have been founded on words recorded in the book of Numbers:—“And it came to pass, when the ark set forward, that Moses said, Rise up, Lord, and let Thine enemies be scattered, and let them that hate Thee flee before Thee. And when it rested, he said, Return, O Lord, unto the many thousands of Israel.” But there are so many expressions in this Psalm which can only be explained with reference to the spiritual triumph of the Church of Christ, that it may be doubted whether it was written with any local or temporary meaning, and whether it is not to be regarded simply as a prophetic hymn of the same character as some portions, and especially the sixtieth chapter, of Isaiah. Such a sense, at least, is the only one in which it can be used in Divine Service.

The XIII. Day.

Morning
Prayer.Acts ii. 4.
Isa. liii. 7.
Rom. x. 15.
Rev. vi. 15.
Isa. liii. 12.
Rev. v. 10.
Isa. lx. 15.
Matt. iii. 16.11 The Lord gave the word : great
was the company of the preachers.12 Kings with their armies did flee,
and were discomfited : and they of the
houshold divided the spoil.13 Though ye have lien among the
pots, yet shall ye be as the wings of
a dove : that is covered with silver
wings, and her feathers like gold.Matt. xiii. 41--43.
Isa. i. 18.
Rev. i. 14.
iii. 5.14 When the Almighty scattered
kings for their sake : then were they
as white as snow in Salmon.15 As the hill of Basan, so is God's
hill : even an high hill, as the hill of
Basan.16 Why hop ye so, ye high hills ?
this is God's hill, in the which it
pleaseth him to dwell : yea, the Lord
will abide in it for ever.Deut. xxxiii. 2, 3.
Gal. iii. 19.
Heb. ii. 2.17 The chariots of God are twenty
thousand, even thousands of angels :
and the Lord is among them, as in
the holy place of Sinai.Eph. iv. 8.
John xv. 26.
xvi. 7.
Acts i. 8.
1 Cor. xii. 11.18 Thou art gone up on high, thou
hast led captivity captive, and received
gifts for men : yea, even for thine
enemies, that the Lord God might
dwell among them.19 Praised be the Lord daily : even
the God who helpeth us, and poureth
his benefits upon us.20 He is our God, even the God of
whom cometh salvation : God is the
Lord, by whom we escape death.

Gen. iii. 15.

21 God shall wound the head of his
enemies : and the hairy scalp of such
a one as goeth on still in his wicked-
ness.Dominus dabit verbum evangelizan-
tibus : virtute multa.Rex virtutum dilecti dilecti : et *virt. dilecti et
speciei*
speciei domus dividere spolia.Si dormiatis inter medios cleros,
pennæ columbæ deargentatæ : et pos-
teriora dorsi ejus in pallore auri. *specie auri*Dum discernit cœlestis reges super
eam, nive dealbabuntur in Selmon :
mons Dei, mons pinguis. *montem Dei mon-
tem uberem*Mons coagulatus, mons pinguis : ut
quid suspicamini montes coagulatos ? *suspicitis montes
uberes*Mons in quo beneplacitum est Deo
habitare in eo : etenim Dominus ha-
bitabit in finem. *usque in finem*Currus Dei decem millibus multi-
plex, millia lætantium : Dominus in
eis, in Sinai in sancto.Ascendisti in altum, cepisti captivi-
tatem : accepisti dona in hominibus. *Ascendens in al-
tum captivam
duxit captivi-
tatem de dii
dona hominibus*Etenim non credentes : inhabitare
Dominum Deum.Benedictus Dominus die quotidie : *de die in diem*
prosperum iter faciet nobis Deus salu-
tarium nostrorum.Deus noster, Deus salvos faciendi :
et Domini Domini exitus mortis.Veruntamen Deus confringet capita *conquassavit*
inimicorum suorum : verticem capilli
perambulantium in delictis suis.

In the first verse, then, in the eighteenth (which is the central one of the Psalm), and in the last, unmistakeable reference is made to our Lord's glorious Resurrection, Ascension, and Session at the right hand of God, as the source of all blessing and glory to the Church : His Resurrection having achieved the victory, His Ascension celebrated the triumph, His Session in "the holy place" within the veil established His Intercessory office on behalf of His people.

The first and second verses contain a metaphor similar to that of Malachi,—“Unto you that fear My Name shall the Sun of Righteousness arise with healing in his wings,” an arising of the Light of the world, before which all the mists of moral and spiritual darkness must fly, in the time of probation ; and before which all enemies must succumb in the Day of Judgment.

The following three verses [4, 5, 6] contain a declaration of the glory of the Lord similar to that in the words of Isaiah, adopted by the Baptist ; the true sense being, “make straight in the deserts a highway for Him that rideth :” and doubtless this is closely analogous to the words of St. John,—“I saw Heaven

opened, and beheld a white horse, and He that sat upon him was called Faithful and True, and in righteousness He doth judge and make war . . . and He hath on His vesture and on His thigh a Name written, KING OF KINGS AND LORD OF LORDS.” [Rev. xix. 16.] Notwithstanding this, He is the Prince of Peace, and under His dispensation of the peace which He left with His Church, the Holy Ghost is ever binding together in one Body the children of God, “making men to be of one mind in an house,” i. e. in the spiritual Temple wherein He dwells.

In the seventh verse the leading of Israël through the wilderness by God is taken as a type of the new Israel going through the world under the leadership of Him respecting Whom the prophet said, “Behold, the Lord God will come with strong hand, and His arm shall rule for Him.” The earth quaked at His Resurrection, when He became the Firstfruits of the great harvest, entering Heaven at the head of a risen army of saints, as the Firstborn among many brethren. So will there be great earthquakes at the Second Advent, when once more He will go forth before the people. And so also, when His Presence with the Church was

The XIII. Day.
Morning.
Prayer.

22 The Lord hath said, I will bring my people again, as I did from Basan : mine own will I bring again, as I did sometime from the deep of the sea.

Rev. xiv. 20.
xix. 11.

23 That thy foot may be dipped in the blood of thine enemies : and that the tongue of thy dogs may be red through the same.

24 It is well seen, O God, how thou goest : how thou, my God and King, goest in the sanctuary.

Exod. xv. 20.

25 The singers go before, the minstrels follow after : in the midst are the damsels playing with the timbrels.

26 Give thanks, O Israel, unto God the Lord in the congregations : from the ground of the heart.

Phil. iii. 5.
Matt. iv. 13.

27 There is little Benjamin their ruler, and the princes of Judah their counsel : the princes of Zabulon, and the princes of Nephthali.

Rev. xxi. 22.
Isa. lx. 2-10.
xlix. 23.
xviii. 7.

28 Thy God hath sent forth strength for thee : stablish the thing, O God, that thou hast wrought in us,

29 For thy temple's sake at Jerusalem : so shall kings bring presents unto thee.

30 When the company of the spearmen and multitude of the mighty are scattered abroad among the beasts of the people, so that they humbly bring pieces of silver : and when he hath scattered the people that delight in war ;

i. e. the land of the Moors.
Rev. xii. 15.

31 Then shall the princes come out of Egypt : the Morians' land shall soon stretch out her hands' unto God.

32 Sing unto God, O ye kingdoms of the earth : O sing praises unto the Lord.

John v. 25.

33 Who sitteth in the heavens over all from the beginning : lo, he doth send out his voice, yea, and that a mighty voice.

Dixit Dominus, Ex Basan convertam : convertam in profundum maris : *convertar in*

Ut intingatur pes tuus in sanguine : *Donec int.*
lingua canum tuorum ex inimicis ab ipso.

Viderunt ingressus tuos, Deus : in- *Visi sunt ingres-*
gressus Dei mei, Regis mei qui est in *sus tui*
sancto.

Prævenierunt principes conjuncti psallentibus : in medio juvenularum *juvenum*
tympanistriarum.

In ecclesiis benedicite Deo : Domino de fontibus Israël.

Ibi Benjamin adolescentulus : in *adolescentior in*
mentis excessu. *pavore*

Principes Jûda, duces eorum : principes Zabulon, et principes Neptalim.

Manda Deus virtuti tuæ : confirma hoc, Deus, quod operatus es in nobis :

A templo tuo in Hierusalem : tibi offerent reges munera.

Increpa feras arundinis, congregatio *sitarum, concilium*
taurorum in vaccis populorum : ut excludant eos qui probati sunt argento. *taurorum ut non excludantur ii qui*

Dissipa gentes quæ bella volunt ; venient legati ex Ægypto : Æthiopia præveniet manus ejus Deo.

Regna terræ, cantate Deo : psallite Domino :

Psallite Deo qui ascendit super cœlum cœli : ad orientem.

again manifested by the coming of the Holy Ghost, and as an answer to the prayer of the Apostles, there was on the one occasion "a rushing mighty wind," while on the other "the place was shaken where they were assembled together." With such signs did God send "the gracious rain" of the Holy Spirit "upon His inheritance," refreshing it when it was weary through the long absence of His manifestations from the ancient Temple and its system.

Passing over many things without further illustration than that contained in the marginal references, the twenty-seventh verse may be selected as showing that nothing is set down at random in Holy Scripture, and that mystical meanings probably underlie almost every idea that it contains. The tribes there named are Benjamin and Judah, Zabulon and Nephthali.

These were the most prominent of all the tribes during the history of Israel as an united people, and Benjamin and Judah were located nearest of all to the holy house of God. From these four tribes, also, sprung all the Apostles of our Lord ; those who were Galilæans belonging to Zabulon and Nephthali, the "brethren" (or "cousins," as we say in modern language) of our Lord to the tribe of Judah, and St. Paul to Benjamin¹.

¹ It is worth remark that St. Paul's name signifies "little," a circumstance which partly suggested, perhaps, his assertion that he was "the least of all the Apostles." It is also to be noted that "little Benjamin their ruler" was represented by the twelfth stone in the breastplate of Aaron, which stone was a jasper. But in the foundations of the wall of the city of God, "the first foundation was jasper," as if signifying that "the last shall be first." [Cf. Exod. xxviii. 20. Rev. xxi. 19.]

The XIII. Day.
Morning
Prayer.
Rev. iv. 1.

34 Ascribe ye the power to God
over Israel : his worship and strength
is in the clouds.

Heb. ix. 12.
Isa. xl. 29—31.

35 O God, wonderful art thou in thy
holy places : even the God of Israel ;
he will give strength and power unto
his people ; blessed be God.

THE LXIX PSALM.

Salvum me fac.

Evening
Prayer.
Good Friday
Evensong.
A Passion Psalm.

Jonah ii. 5.

SAVE me, O God : for the waters are
come in, even unto my soul.

2 I stick fast in the deep mire,
where no ground is : I am come into
deep waters, so that the floods run over
me.

3 I am weary of crying, my throat
is dry : my sight faileth me for wait-
ing so long upon my God.

John xv. 25.

4 They that hate me without, a
cause are more than the hairs of my
head : they that are mine enemies,
and would destroy me guiltless, are
mighty.

2 Cor. v. 21.

5 I paid them the things that I
never took : God, thou knowest my
simpleness, and my faults are not hid
from thee.

Mark viii. 33.
Gal. v. 11.
Matt. xi. 6.

6 Let not them that trust in thee,
O Lord God of hosts, be ashamed for
my cause : let not those that seek thee
be confounded through me, O Lord
God of Israel.

Jer. xv. 15.

7 And why? for thy sake have I
suffered reproof : shame hath covered
my face.

John xviii. 8.
Mark xi. 50.

8 I am become a stranger unto my
brethren : even an alien unto my
mother's children.

Ecce dabit voci suæ vocem virtutis ; vocem suam vocem
date gloriam Deo super Israël : magni-
ficentia ejus et virtus ejus in nubibus.

Mirabilis Deus in sanctis suis : Deus
Israël ipse dabit virtutem et fortitudi-
nem plebi suæ ; benedictus Deus.

PSALMUS LXVIII.

Thursd. Mattins.
Maundy Thurs.
1st Noct.

SALVUM me fac Deus : quoniam
intraverunt aquæ usque ad animam
meam.

Infixus sum in limo profundi : et
non est substantia.

Veni in altitudinem maris : et tem-
pestas demersit me.

Laboravi clamans, raucæ factæ sunt
fauces meæ : defecerunt oculi mei,
dum spero in Deum meum.

Multiplicati sunt super capillos capi-
tis mei : qui oderunt me gratis,

Confortati sunt qui persecuti sunt super me qui me
persequuntur
me inimici mei injuste : quæ non rapui,
tunc exsolvebam.

Deus, tu scis insipientiam meam :
et delicta mea a te non sunt abscon-
dita.

Non erubescant in me qui exspectant
te Domine : Domine virtutum.

Non confundantur super me : qui revereantur
quærunte te, Deus Israël.

Quoniam propter te sustinui oppro- supportavi impro-
perium reve-
rentia
brium : operuit confusio faciem meam.

Extraneus factus sum fratribus meis : Exter . . . et
hospis
et peregrinus filiis matris meæ.

Thus the princes of these tribes represent those princes of the Church, of whom our Lord said, that they should sit on twelve thrones judging the twelve tribes of Israel ; those by whom " He sent forth strength for " His Church, and established the thing that He had wrought for His Temple's sake, the Temple of the Holy Ghost, in His New Jerusalem.

PSALM LXIX.

This awful prophecy of our Blessed Saviour's Passion is much quoted in the New Testament, and seems to have been often in the minds of Christ and His Apostles when not directly quoted by them. It has also a strong analogy with some portions of the prophecy and the Lamentations of Jeremiah, whose great sufferings seem to have been typical, in the highest degree, of the Passion of the Lord.

The cry of anguish with which the Psalm opens is of the same

nature as others which are heard from the lips of Christ in other Psalms, and it testifies here and elsewhere to the thoroughly human character of that human nature which He bore ; so human that it was liable to the same fear of death which all experience. Hezekiah in his sickness, Jonah in the deep of the sea, Jeremiah in the mire of the pit, were all types of our Lord in this : but great as were their troubles and their fears, they were not overwhelmed as He was by the " floods of ungodliness " borne for others, nor had their fear of death that supernatural character which made His so infinitely painful. Yet, though He called upon the Father to save Him, He would not shorten or lessen His own suffering. He saved others, and He could have saved Himself : He walked upon the natural waters, but He suffered Himself to sink into the miry bed of that sea of persecution which surrounded Him : He comforted the penitent thief with the loving promise, " To-day shalt thou

The XIII. Day.
Evening
Prayer.
John ii. 17
Rom. xv. 3.

9 For the zeal of thine house hath even eaten me : and the rebukes of them that rebuked thee are fallen upon me.

10 I wept and chastened myself with fasting : and that was turned to my reproof.

Lament. iii. 14. 11 I put on sackcloth also : and they jested upon me.

i. e. the rulers.
Lament. iii. 68.
Job xxx. 9. 12 They that sit in the gate speak against me : and the drunkards make songs upon me.

Luke xxiii. 44.
46.
1 Kings xix. 36.
Ezra ix. 5.
Dan. ix. 21. 13 But, Lord, I make my prayer unto thee : in an acceptable time.

14 Hear me, O God, in the multitude of thy mercy : even in the truth of thy salvation.

Jer. xxxviii. 6. 22. 15 Take me out of the mire, that I sink not : O let me be delivered from them that hate me, and out of the deep waters.

Lament. iii. 55.
Numb. xvi. 33. 16 Let not the water-flood drown me, neither let the deep swallow me up : and let not the pit shut her mouth upon me.

17 Hear me, O Lord, for thy loving-kindness is comfortable : turn thee unto me according to the multitude of thy mercies.

Lament. iii. 56. 18 And hide not thy face from thy servant, for I am in trouble : O haste thee, and hear me.

Lament. iii. 57. 19 Draw nigh unto my soul, and save it : O deliver me, because of mine enemies.

Quoniam zelus domus tuæ comedit me : et opprobria exprobrantium tibi, ceciderunt super me.

Et operui in jejuniis animam meam : et factum est in opprobrium mihi.

Et posui vestimentum meum cilicium : et factus sum illis in parabolam.

Adversum me loquebantur qui sedebant in porta : et in me psallebant qui bibebant vinum.

Ego vero orationem meam ad te, Domine : tempus beneplaciti, Deus.

In multitudine misericordiæ tuæ exaudi me : in veritate salutis tuæ.

Eripe me de luto, ut non infigar : libera me ab his qui oderunt me, et de profundis aquarum.

* Non me demergat tempestas aquæ : neque absorbeat me profundum ; neque urgeat super me puteus os suum.

Exaudi me, Domine, quoniam benigna est misericordia tua : secundum multitudinem miserationum tuarum respice in me.

Et ne avertas faciem tuam a pueris tuis : quoniam tribulor, velociter exaudi me.

Intende animæ meæ, et libera eam : propter inimicos meos eripe me. me Domine

be with Me in Paradise;" but for Himself was the cry of woe, "My God, My God, why hast Thou forsaken Me?" ever ready to hear the cry of others, He Himself, for our sins, was "weary of crying," His "sight failing through waiting so long upon His God."

Thus, throughout this Psalm, the intensity of Christ's sufferings is set forth in language equalled only in its awful sadness by the twenty-second Psalm. He is guiltless and alone, and weak with weeping and fasting; His enemies are mighty, and more in number than the hairs of His head. The sins of those who sinned against God are fallen upon Him Who knew no sin. He exchanged the joys of Heaven for the sorrows of earth, fasted from the Presence of His Father, and put on the sackcloth of human nature; His loving work was turned to His reproof, so that when He spoke of God as His Father, they charged Him with blasphemy, and, instead of beholding His immaculate Human Nature, called Him the "son of the carpenter;" the judges that "sat in the gate" condemned Him unjustly, and the foolish soldiers and passers by reviled Him.

But, in the midst of all this sorrowing prophecy of Christ's Passion, there is a continual appeal from the injustice of man to the justice and love of God; and also a constant declaration of the great Truth that Christ suffered for the sins of mankind.

Thus, "They that hate Me *without a cause*" "I paid them the thing that I never took" "They that would destroy Me *guiltless*" "God, *Thou* knowest My simpleness, and My faults are not hid from *Thee*" "For Thy sake have I suffered reproof" "The zeal of Thine house hath even eaten Me" "But, Lord, I make My prayer unto Thee" "Hear Me, O Lord, for Thy loving-kindness is comfortable" "Thou hast known My reproof, My shame, and My dishonour" "Thy rebuke hath broken My heart."

Thus did the spotless Lamb of God plead from the midst of the fire of the sacrifice, pleading not for Himself, but for others. Thus did He pray that the sin by which He was borne down might be removed from Him, that it might be removed from those for whom He bore it. Thus did He cry "Save Me," "Take Me out of the deep waters," that, being Himself saved, He might be "mighty to save" all men. Thus did He hold forth His broken heart as an atonement for the hard hearts of sinners.

Like all Psalms of our Lord's Passion, this also ends in a song of Resurrection joy; and in the expressions used we may trace clearly the manner in which Christ's Death, Descent into Hell, Resurrection, and Ascension, are all events in which the redeemed are made partakers through their union with Him. So the Lord hears the intercessions of the Poor, and the prisoners of hope

<p>The XIII. Day. <i>Evening</i> <i>Prayer.</i> Lament. iii. 61.</p> <p>John xix. 34.</p> <p>Lament. iii. 5. Matt. xxvii. 34 John xix. 29.</p> <p>Rom. xi. 9, 10. 2 Cor. ii. 16.</p> <p>Isa. xlii. 18. John xii. 40. Acts xxviii. 26. 2 Cor. iii. 14.</p> <p>Acts i. 20.</p> <p>Isa. liii. 4, 5.</p> <p>Matt. xxiii. 32.</p>	<p>20 Thou hast known my reproof, my shame, and my dishonour : mine adversaries are all in thy sight.</p> <p>21 Thy rebuke hath broken my heart ; I am full of heaviness : I looked for some to have pity on me, but there was no man, neither found I any to comfort me.</p> <p>22 They gave me gall to eat : and when I was thirsty they gave me vinegar to drink.</p> <p>23 Let their table be made a snare to take themselves withal : and let the things that should have been for their wealth be unto them an occasion of falling.</p> <p>24 Let their eyes be blinded, that they see not : and ever bow thou down their backs.</p> <p>25 Pour out thine indignation upon them : and let thy wrathful displeasure take hold of them.</p> <p>26 Let their habitation be void : and no man to dwell in their tents.</p> <p>27 For they persecute him whom thou hast smitten : and they talk how they may vex them whom thou hast wounded.</p> <p>28 Let them fall from one wicked- ness to another : and not come into thy righteousness.</p>	<p>Tu scis improprium meum et Tu enis confusionem meam : et reverentiam <i>verecundiam</i> meam.</p> <p>In conspectu tuo sunt omnes qui tri- bulant me : improprium expectavit cor meum et miseriam.</p> <p>Et sustinui qui simul contristaretur <i>meum contr.</i> et non fuit : et qui consolaretur, et non <i>et consolantem me</i> inveni. <i>quasi et</i></p> <p>Et dederunt in escam meam fel : et in siti mea potaverunt me aceto.</p> <p>Fiat mensa eorum coram ipsis in laqueum : et in retributiones et in scandalum.</p> <p>Obscurentur oculi eorum ne videant : et dorsum eorum semper incurva.</p> <p>Effunde super eos iram tuam : et furore iræ tuæ comprehendat eos. <i>indignatio iræ</i></p> <p>Fiat habitatio eorum deserta : et in tabernaculis eorum non sit qui inha- bitet.</p> <p>Quoniam quem tu percussisti, per- secuti sunt : et super dolorem vulne- rum meorum addiderunt.</p> <p>Appone iniquitatem super iniqui- tatem eorum : et non intrent in jus- titiam tuam.</p>
--	--	--

are released from their dark dungeon of death, to live in the light of Paradise ; the City of God is built up out of Christ's own Body, and all they which are written in the Lamb's book of life shall inherit it : "and every creature which is in Heaven, and on the earth, and under the earth, and such as are in the sea, and all that are in them," shall be heard "saying, Blessing, and honour, and glory, and power, be unto Him that sitteth upon the throne, and unto the Lamb," even the Lamb as it had been slain, "for ever." [Rev. v. 13.]

§ *The Imprecations.*

Gentle-minded and loving Christians have often felt a difficulty in the use of those Psalms which, like the sixty-ninth, contain such strong expressions of feeling towards evil-doers as are apparently inconsistent with the precepts of charity enjoined in the New Testament. Psalms of this character have been sometimes called the "cursing" or "imprecatory" Psalms, and the spirit of them has been supposed to be so thoroughly Judaical as to make them unsuitable for use by the Christian Church. But such ideas respecting them are founded on an insufficient appreciation of the true sense in which all the Psalms are to be regarded : and they are, perhaps, accompanied by a too limited application of them to the experience and circumstances of the individual person who uses them.

It should be remembered as a first principle in the use of the imprecatory Psalms, that the imprecations are uttered against the enemies of God, not against those of David or any other

merely human person. It may be doubted whether the sweet singer of Israel could ever have uttered them in any but a prophetic sense, for he was of too meek, forgiving, and tender a character to entertain so strong a spirit of vengeance as the personal application of his words would imply. When Saul was a most bitter enemy to him, David twice refrained from taking his life, though the king was completely in his power : when Shimei cursed him with the most shameful imprecations, he forgave him as a man, although as a righteous ruler he could not altogether overlook the crime committed against the sovereign's person : when his rebellious son Absalom died, the most pathetic tenderness was exhibited by the bereaved father, so that his "O Absalom, my son, my son," shadows forth the "O Jerusalem, Jerusalem," of the Son of David in after ages.

It was, therefore, as an inspired prophet, and not as a private writer, that David wrote the maledictions of the Psalms ; and he wrote them, not respecting any men because they were enemies of his own, but because they were enemies of his God. In the same spirit they are to be used by the Christian Church.

And this particular Psalm contains some striking references to the *facts* of the Crucifixion, which furnish a key to the use of the maledictions or imprecations wherever they are found. For these references to facts, which belong exclusively to the sufferings of our Lord, show that the enemies of Christ are those against whom the terrible words are recorded : as, also, that they are spoken in the Person of Christ, the righteous and most merciful Judge of all men. Thus we are led to the Gospel narrative,

The XIII. Day. *Evening Prayer.* 29 Let them be wiped out of the book of the living : and not be written among the righteous.

Lament. iii. 66. Rev. xx. 15. xxi. 27. Matt. v. 11. 30 As for me, when I am poor and in heaviness : thy help, O God, shall lift me up.

Jonah ii. 9. 31 I will praise the Name of God with a song : and magnify it with thanksgiving.

Heb. ix. 23. 32 This also shall please the Lord : better than a bullock that hath horns and hoofs.

John v. 25. vi. 57. xiv. 19. Isa. xl. 31. 33 The humble shall consider this, and be glad : seek ye after God, and your soul shall live.

Zech. ix. 12. Isa. xlii. 7. 1 Pet. iii. 19. 34 For the Lord heareth the poor : and despiseth not his prisoners.

35 Let heaven and earth praise him : the sea, and all that moveth therein.

Isa. xlv. 26. Rev. xxi. 10—23. 36 For God will save Sion, and build the cities of Judah : that men may dwell there, and have it in possession.

Isa. liii. 10. Rev. xxi. 27. 37 The posterity also of his servants shall inherit it : and they that love his Name shall dwell therein.

THE LXX PSALM.

Deus, in adiutorium.

Ps. xl. 16. **H**ASTE thee, O God, to deliver me : make haste to help me, O Lord.

Deleantur de libro viventium : et cum justis non scribantur.

Ego sum pauper et dolens : salus tua, *et salus vultus tui* Deus, suscepit me.

Laudabo Nomen Dei cum cantico : et magnificabo eum in laude.

Et placebit Deo super vitulum novellum : cornua producentem et ungulas.

Videant pauperes et lætentur : quærite Deum, et vivet anima vestra.

Quoniam exaudivit pauperes Dominus : et victos suos non desepxit. *sprevit*

Laudent illum cœli et terra : mare et omnia reptilia in eis. *et omnia quæ in eis sunt*

Quoniam Deus salvam faciet Sion : et ædificabuntur civitates Judææ

Et inhabitabunt ibi : et hæreditate acquirent eam.

Et semen servorum ejus possidebit eam : et qui diligunt Nomen ejus habitabunt in ea.

PSALMUS LXIX.

DEUS, in adiutorium meum intende : Domine, ad adjuvandum me festina. *Thursd. Mattins. Maundy Thursd., 1st Noct.*

and to the historical words of Christ, to examine whether any thing analogous is to be found in the record of His meek, loving, and gentle life. And there it is to be observed, that He Who uttered the eight Benedictions in the Sermon on the Mount, also uttered the eight woes in the very same discourse : that He Who was merciful to repentant publicans and sinners, denounced unrepentant hypocrites in terms of extreme sternness as a "generation of vipers," and meted out to them words of most bitter scorn and condemnation : that He Who wept over Jerusalem, predicted at the same time, and in the terms of one passing a judicial sentence, that fearful siege and destruction, the details of which are unmatched for horror in the history of the world : that He Who prayed for His murderers, "Father, forgive them," was the same Who revealed His own future words, "Depart, ye cursed, into everlasting fire."

Remembering the disposition towards sinners which was entertained by the Saviour Who came to give up His life for them, we thus arrive at the conclusion that the more perfect the love of God and of souls is, the more decided and definite is the righteous indignation which is felt against those who dishonour the One, and ruin the other. And a further indication of this is found in the fact that it was the "Apostle of love" who wrote most severely of all the Apostles against unbelievers : and who was chosen by God to wind up the words of Holy Writ with the fearful maledictions, "He that is unjust, let him be unjust still ; and he which is filthy, let him be filthy still" . . . "If any man shall add unto these things, God shall add unto him the

plagues that are written in this book ; and if any man shall take away from the words of the book of this prophecy, God shall take away his part out of the book of life, and out of the holy city, and from the things which are written in this book." [Rev. xxii. 11, 18, 19.]

The imprecations of the Psalms are, then, utterances of that "wrath of the Lamb," to fly from which, sinners, the enemies of Christ, will at the last call upon the rocks and hills to fall upon them, hide them, and annihilate them. [Rev. vi. 15—17.] They are spoken respecting those who finally refuse to become His friends, and who reject for ever the redeeming love which would have won them to His fold. When they are sung or said in the course of Divine Service or in private devotion, there must be no thought of applying them to any particular persons, or of taking them as words which have any reference to our own real or supposed wrongs. They are the words of Christ and His Church, not our words spoken as individual persons : they are uttered against the finally impenitent ; and who these are the Great Judge of all alone can decide. They must be used, therefore, in the spirit in which the martyrs cry, "Lord, how long," in which the Church Militant prays day by day, "Thy Kingdom come," and in which at the last, notwithstanding the horrors attending the Last Judgment, the Bride will respond to "Him that testifieth, I come quickly," "Even so, come, Lord Jesus."

PSALM LXX.

This Psalm is almost identical with the last six verses of the
3 G 2

The XIII. Day.
Evening Prayer.
Ps. xl. 17. 2 Let them be ashamed and confounded that seek after my soul : let them be turned backward and put to confusion that wish me evil.

Ps. xl. 18. 3 Let them for their reward be soon brought to shame : that cry over me, There, there.

Ps. xl. 19. 4 But let all those that seek thee be joyful and glad in thee : and let all such as delight in thy salvation say always, The Lord be praised.

Ps. xli. 20. 5 As for me, I am poor and in misery : haste thee unto me, O God.

Ps. xl. 21. 6 Thou art my helper, and my redeemer : O Lord, make no long tarrying.

THE LXXI PSALM.

In te, Domine, speravi.

The XIV. Day.
Morning Prayer.
Visitation of the Sick.
Ps. xxxi. 1, 2. **I**N thee, O Lord, have I put my trust, let me never be put to confusion : but rid me, and deliver me in thy righteousness ; incline thine ear unto me, and save me.

Ps. xxxi. 3, 4. 2 Be thou my strong hold, whereunto I may always resort : thou hast promised to help me, for thou art my house of defence and my castle.

3 Deliver me, O my God, out of the hand of the ungodly : out of the hand of the unrighteous and cruel man.

4 For thou, O Lord God, art the thing that I long for : thou art my hope, even from my youth.

Matt. i. 20.
Luke ii. 52.
Matt. iii. 17. 5 Through thee have I been holden up ever since I was born : thou art he that took me out of my mother's womb ; my praise shall be always of thee.

i. e. a miraculous prodigy.
Isa. viii. 18.
Zech. iii. 8.
Luke ii. 34. 6 I am become as it were a monster unto many : but my sure trust is in thee.

Confundantur et revereantur : qui revereantur iniqui
huic me qui quaerunt animam meam.

Avertantur retrorsum et erubescant : qui volunt mihi mala.

Avertantur statim erubescences : qui dicunt mihi, Euge, euge. cogitant

Exultent et lætentur in te omnes qui lætentur qui quaerunt te quaerunt te : et dicant semper, Magnificetur Dominus, qui diligunt salutare tuum.

Ego vero egenus et pauper sum : Deus, adjuva me.

Adjutor meus et liberator meus es tu : Domine, ne moreris. retardaveris

PSALMUS LXX.

IN te Domine speravi, non confundar Thursd. Mattins.
Maundy Thursd.,
1st Noct. in æternum : in justitia tua libera me et eripe me.

Inclina ad me aurem tuam : et salva libera me.

Estò mihi in Deum protectorem, et in locum munitum : ut salvum me facias.

Quoniam firmamentum meum : et refugium meum es tu.

Deus meus, eripe me de manu peccatoris : et de manu contra legem agentis et iniqui. iniqua

Quoniam tu es patientia mea, Domine : Domine, spes mea a juventute mea.

In te confirmatus sum ex utero : de ventre matris meæ tu es protector meus :

In te cantatio mea semper : tanquam prodigium factus sum multis, et tu adjutor fortis.

fortieth ; but, as the second book of the Psalms is chiefly spoken in the person of Christ's Mystical Body, while the first is chiefly spoken in the Person of Christ Himself, so it has been thought that this Psalm is the voice of the Church crying out, "Lord, how long," at a period of great tribulation.

It is observable that the language of the second and third verses is such as will bear an interpretation of blessing rather than cursing. Saul sought after the souls of those whom he dragged to prison, and of God's holy martyr Stephen, and while he was "breathing out slaughters" such shame and confusion fell upon him, and so was he "turned backward," that he was converted to become a life servant and martyr of that Lord Who said to him, "Saul, Saul, why persecutest thou Me?" [Acts vii. 58 ; ix. 4.] Many persecutors are known to have been converted to Christ in

those ages, and doubtless there were among them some of those very men who had cried, "There, there," against the Lord Himself.

In praying, therefore, "Make haste to help me, O Lord," the Church prays in the same tone which the merciful Jesus taught when He bade us pray daily, "Thy Kingdom come ;" that all, even the enemies and persecutors of Christ, may be brought, like St. Paul, to be joyful and glad in Him.

PSALM LXXI.

Although the subject of this Psalm is the same as that of the preceding, its subdued tone and the absence of any expressions of extreme anguish give it quite a different character. While the one may be supposed to represent the bitter pain of the Cross,

The XIV. Day.
Morning
Prayer.

7 O let my mouth be filled with thy praise : that I may sing of thy glory and honour all the day long.

Rev. i. 14.
2 Cor. xii. 10.

8 Cast me not away in the time of age : forsake me not when my strength faileth me.

9 For mine enemies speak against me, and they that lay wait for my soul take their counsel together, saying : God hath forsaken him ; persecute him, and take him, for there is none to deliver him.

10 Go not far from me, O God : my God, haste thee to help me.

Rev. xx. 10.

11 Let them be confounded and perish that are against my soul : let them be covered with shame and dishonour that seek to do me evil.

12 As for me, I will patiently abide always : and will praise thee more and more.

13 My mouth shall daily speak of thy righteousness and salvation : for I know no end thereof.

14 I will go forth in the strength of the Lord God : and will make mention of thy righteousness only.

15 Thou, O God, hast taught me from my youth up until now : therefore will I tell of thy wondrous works.

Rev. i. 14.

16 Forsake me not, O God, in mine old age, when I am gray-headed : until I have shewed thy strength unto this generation, and thy power to all them that are yet for to come.

Rom. viii. 35.

17 Thy righteousness, O God, is very high : and great things are they that thou hast done ; O God, who is like unto thee ?

Repleatur os meum laude ut cantem ut possim cantare
gloriam tuam : tota die magnitudinem magnificentiam
tuam.

Ne projicias me in tempore senectutis : cum defecerit virtus mea, ne derelinquas me.

Quia dixerunt inimici mei mihi : et mala mihi
qui custodiebant animam meam consilium fecerunt in unum.

Dicentes, Deus dereliquit eum : persequimini et comprehendite eum ; quia non est qui eripiat.

Deus, ne elongeris a me : Deus meus, in auxilium meum respice.

Confundantur et deficiant detrahentes animæ meæ : operiantur confusione et pudore qui quæruni mala mihi.

Ego autem semper sperabo : et adjiciam in te sperabo Domine
super omnem laudem tuam.

Os meum annuntiabit justitiam pronuntiabit
tuam : tota die salutare tuum.

Quoniam non cognovi litteraturam, negotiationes
introibo in potentias Domini : Domine memorabor justitiæ tuæ solius.

Deus, docuisti me a juventute mea : et usque nunc pronuntiabo mirabilia tua.

Et usque in senectam et senium : Deus, ne derelinquas me :

Donec annuntiem brachium tuum : generationi omni quæ ventura est :

Potentiam tuam et justitiam tuam, Deus, usque in altissima, quæ fecisti magnalia : Deus, quis similis tibi ?

the other may be taken as illustrating the period immediately preceding the Resurrection, when the remembrance of the Passion has not yet given place to the triumphant joy of a completed Victory. It is the same Voice which said, "Thou shalt not leave My soul in Hell, neither wilt Thou suffer Thine Holy One to see corruption." Thus the Psalm represents to us the "patient abiding away" of the holy Jesus, waiting for the arrival of the appointed time for Him to be brought from the deep of the earth again, going forth in the strength of the Divine Nature, and never doubting the righteousness of the Divine Will¹.

From the fourth to the eighth verses inclusive, and also in the fifteenth and sixteenth, there are such references to the duration of our Lord's life on earth as seem to indicate that, although it continued for only thirty-three years, yet every period of man's

life was represented by, or condensed into it. "Cast Me not away in the time of age," may well lead us to believe that the closing part of our suffering Redeemer's time of humiliation was, to Him, as the concluding part of an old man's life, rather than that of a man in the vigour of youth ; and that in so many years as are reckoned to one generation He exhausted the experiences of the longest lifetime. There may be, also, in the expression, "Forsake Me not when My strength faileth Me," and in the pleading of the two following verses, a prayer that the Godhead may yet continue with the Manhood, even when the strength of the Incarnation [see note on Psalm xciii. 1] seemed to be failing in the last epoch of Christ's humiliation, the Descent into Hell. If so, then these verses show that Christ's enemies were not quieted by His death, but that the great Adversary and his hosts "lay wait for" His "soul," under the impression that it was forsaken by the Divine Nature when they beheld it separated from His Body. It cannot be doubted, that, to the Omniscient Eye which foresaw the events of Christ's Passion in the time of

¹ It is observable that although the first part of this Psalm is identical with the first part of the thirty-first, the special compline words of our Lord, "Into Thy hands I commend My spirit," are not found here.

The XIV. Day.
*Morning
Prayer.*
Rom. x. 7.
Eph. iv. 9.

18 O what great troubles and adversities hast thou shewed me! and yet didst thou turn and refresh me : yea, and broughtest me from the deep of the earth again.

Acts vii. 56.
Rev. i. 13.
v. 5-10.

19 Thou hast brought me to great honour : and comforted me on every side.

20 Therefore will I praise thee and thy faithfulness, O God, playing upon an instrument of musick : unto thee will I sing upon the harp, O thou Holy One of Israel.

21 My lips will be fain when I sing unto thee : and so will my soul whom thou hast delivered.

Rev. xxi. 14.

22 My tongue also shall talk of thy righteousness all the day long : for they are confounded and brought unto shame that seek to do me evil.

THE LXXII PSALM.

Deus, judicium.

Luke i. 32.
John v. 22.
Isa. ix. 6.

GIVE the King thy judgements, O God : and thy righteousness unto the King's son.

Isa. xxxii. 1.
Matt. v. 3. 17.

2 Then shall he judge thy people according unto right : and defend the poor.

Micah iv. 3.

3 The mountains also shall bring peace : and the little hills righteousness unto the people.

4 He shall keep the simple folk by their right : defend the children of the poor, and punish the wrong doer.

5 They shall fear thee, as long as the sun and moon endureth : from one generation to another.

Quantas ostendisti mihi tribulationes multas et malas; et conversus vivificasti me : et de abyssis terræ iterum reduxisti me.

Multiplicasti magnificentiam tuam : *justitiam*
et conversus consolatus es me. *et*

Nam et ego confitebor tibi in vasis psalmi : veritatem tuam, Deus ; psallam tibi in cithara, sanctus Israël.

Exsultabunt labia mea cum cantavero *Gaudebunt*
tibi : et anima mea quam redemisti.

Sed et lingua mea tota die meditabitur *mea (tota die)*
justitiam tuam : cum confusi et reveriti fuerint qui quærunt mala mihi.

PSALMUS LXXI.

DEUS, judicium tuum Regi da : et *Thursd. Mattins.*
justitiam tuam Filio Regis : *Christmas, Epi-*
phany, Maundy
Thursday,
Trinity Sund.,
2nd Noct.

Judicare populum tuum in justitia : *justitia tua*
et pauperes tuos in judicio.

Suscipiant montes pacem populo : *populo tuo*
et colles justitiam.

Judicabit pauperes populi, et salvos *In sua justitia*
faciet filios pauperum : et humiliabit *judicabit*
calumniatorem.

Et permanebit cum sole et ante
lunam : in generatione et generatio- *in saeculum saeculi*
nem.

the Psalmist, the spiritual foes of the Redeemer must have been as penetratingly known, at least, as those who visibly stood in the hall of Pilate, or around the Cross.

Like all Psalms which relate to the sufferings of our Lord, this one ends in tones of joy and triumph :—"O what great troubles and adversities hast Thou showed Me" in My Life and My Death, "and yet didst Thou turn and refresh Me" in Paradise, "yea, and broughtest Me from the deep of the earth again" by the re-union of Body and Soul in a glorious Resurrection.

A manifest application of this Psalm to the Church, and to Christians in a time of sickness, is suggested by the words of the prophet Isaiah :—"They that wait upon the Lord shall renew their strength; they shall mount up with wings as eagles; they shall run, and not be weary; and they shall walk, and not faint." [Isa. xl. 31.] As Christ was a "wonder" unto many, so His Church has sometimes been so far partaker in His sufferings as to say, "We are made a spectacle unto the world, and to angels, and to men." [1 Cor. iv. 9.] But such afflictions draw

closer the bonds of union between the Head and the members, and will enable Him to say at last, "Behold, I and the children whom the Lord hath given Me are for signs and for wonders in Israel from the Lord of hosts, which dwelleth in Mount Zion." [Isa. viii. 18. Heb. ii. 13.]

PSALM LXXII.

These words of prophetic joy were ever considered by the Jews to be spoken of the Messiah and His Kingdom : to the Christian, with the light of the Gospel and the history of the Church before him, this Psalm can have no other meaning¹. If it ever had a partial application to Solomon, it could only have been in a very inferior degree applied to him as a type of the Son of David, Whose

¹ The neglect of the spiritual interpretation of the Psalms is painfully illustrated by a perversion of the seventh verse in the hymn ordered instead of *Venite Exultemus* in the "Accession Service." Some other perversions in this hymn are equally objectionable.

The XIV. Day. Morning Prayer. Judg. vi. 37. Ps. lxxviii. 9. Rev. xii. 1.

6 He shall come down like the rain into a fleece of wool : even as the drops that water the earth.

7 In his time shall the righteous flourish : yea, and abundance of peace, so long as the moon endureth.

Rev. xi. 15. Micah vii. 12.

8 His dominion shall be also from the one sea to the other : and from the flood unto the world's end.

9 They that dwell in the wilderness shall kneel before him : his enemies shall lick the dust.

Isa. lx. 9. Zeph. ii. 11. Matt. xii. 42.

10 The kings of Tharsis and of the isles shall give presents : the kings of Arabia and Saba shall bring gifts.

Rev. iv. 10. xxi. 24.

11 All kings shall fall down before him : all nations shall do him service.

2 Cor. viii. 9.

12 For he shall deliver the poor when he crieth : the needy also, and him that hath no helper.

13 He shall be favourable to the simple and needy : and shall preserve the souls of the poor.

Rev. vi. 10. xix. 2.

14 He shall deliver their souls from falsehood and wrong : and dear shall their blood be in his sight.

Rev. i. 18.

15 He shall live, and unto him shall be given of the gold of Arabia : prayer shall be made ever unto him, and daily shall he be praised.

John xii. 24. Rev. xxii. 2.

16 There shall be an heap of corn in the earth, high upon the hills : his fruit shall shake like Libanus, and shall be green in the city like grass upon the earth.

17 His Name shall endure for ever ; his Name shall remain under the sun among the posterities : which shall be blessed through him ; and all the heathen shall praise him.

Descendet sicut pluvia in vellus : et sicut stillicidia stillantia super terram.

Orietur in diebus ejus justitia, et abundantia pacis : donec auferatur extollatur luna.

Et dominabitur a mari usque ad mare : et a flumine usque ad terminos orbis terrarum.

Coram illo procident Æthiopes : et inimici ejus terram lingent.

Reges Tharsis et insulæ munera offerent : reges Arabum et Saba dona adducent.

Et adorabunt eum omnes reges : omnes gentes servient ei.

Quia liberabit pauperem a potente : et pauperem cui non erat adjutor. *et inopem*

Parcet pauperi et inopi : et animas pauperum salvas faciet.

Ex usuris et iniquitate redimet *liberabit* animas eorum : et honorabile nomen *preclarum* eorum coram illo.

Et vivet et dabitur ei de auro Arabiæ : et adorabunt de ipso semper ; tota die benedicent ei.

Erit firmamentum in terra in summis montium ; superextolletur super Libanum fructus ejus : et florebunt de civitate sicut fœnum terræ.

Sit Nomen ejus benedictum in sæcula : ante solem permanet Nomen ejus. *permanet nomen ejus et ante lunam sæcis ejus*

Et benedicentur in ipso omnes tribus terræ : omnes gentes magnificabunt eum.

glorious reign was to be universal and without end ; and of Whom another prophet wrote, "Behold, a King shall reign in righteousness, and princes shall rule in judgment. And a Man shall be as an hiding-place from the wind, and a covert from the tempest ; as rivers of water in a dry place ; as the shadow of a great rock in a weary land." "For unto us a Child is born, unto us a Son is given : and the government shall be upon His shoulder ; and His Name shall be called Wonderful, Counsellor, The mighty God, The everlasting Father, The Prince of Peace. Of the increase of His government and peace there shall be no end, upon the throne of David, and upon His Kingdom, to order it, and to establish it with judgment and with justice, from henceforth even for ever." "Behold, a greater than Solomon is here."

The perpetuity, the universality, and the infinite blessings of Christ's Kingdom are, then, mystically set forth in this Psalm. Christ came among the Jews as the rain upon Gideon's fleece, leaving all around dry : but as the fleece was afterwards left dry

while all around it fell the rain, so, when He was rejected by His own nation, He caused the Gentile world to blossom and bear fruit. He came, therefore, to establish an universal dominion "from sea to sea," even to the "utmost bounds of the earth," to establish also a "Kingdom of God within" us, from the sea of Baptism to the sea of glass before the throne, one from the flood to the world's end, even from the flood of destruction to the "river of the water of life." And it is very observable that this perpetual and universal Kingdom depends altogether on the "righteousness" of the King's Son, that immaculate holiness and obedience which enabled Him to be the Saviour of sinners. the "work" of which is "peace," and the effect of it "quietness and assurance for ever."

To Him, then, is the "gold" of worship and the incense of

1 "Tharsis and the isles" indicate all known and unknown regions lying beyond the Straits of Gibraltar.

The XIV. Day.
Morning
Prayer.

18 Blessed be the Lord God, even the God of Israel : which only doeth wondrous things ;

Isa. vi. 3.
Rev. xviii. 1.

19 And blessed be the Name of his Majesty for ever : and all the earth shall be filled with his Majesty. Amen, Amen.

THE LXXIII PSALM.

Quam bonus Israel !

Evening
Prayer.

TRULY God is loving unto Israel : even unto such as are of a clean heart.

2 Nevertheless, my feet were almost gone : my treadings had well-nigh slipt.

Jer. xii. 1—4.

3 And why ? I was grieved at the wicked : I do also see the ungodly in such prosperity.

Job xxi. 7—9.

4 For they are in no peril of death : but are lusty and strong.

Luke xvi. 19.

5 They come in no misfortune like other folk : neither are they plagued like other men.

6 And this is the cause that they are so holden with pride : and overwhelmed with cruelty.

Luke xii. 18.

7 Their eyes swell with fatness : and they do even what they lust.

Job xxi. 14.
Rev. xiii. 6.

8 They corrupt other, and speak of wicked blasphemy : their talking is against the most High.

al. "into."

9 For they stretch forth their mouth unto the heaven : and their tongue goeth through the world.

10 Therefore fall the people unto them : and thereout suck they no small advantage.

Benedictus Dominus Deus Israël :
qui facit mirabilia solus :

magna

Et benedictum Nomen majestatis
ejus in æternum : et replebitur majes- in æternum et in
tate ejus omnis terra. Fiat, fiat. sæculum sæculi

PSALMUS LXXII.

QUAM bonus Israël Deus : his qui Thursd. Mattins.
Maundy Thursd.,
2nd Noct.
recto sunt corde.

Mei autem pene moti sunt pedes :
pene effusi sunt gressus mei.

Quia zelavi super iniquos : pacem
peccatorum ydens. in peccatoribus

Quia non est respectus morti eorum : declinatio morti
eorum nec
et firmamentum in plaga eorum.

In labore hominum non sunt : et
cum hominibus non flagellabuntur.

Ideo tenuit eos superbia : operti
sunt iniquitate et impietate sua.

Prodiit quasi ex adipe iniquitas
eorum : transierunt in affectum cordis. in disputatione
Cogitaverunt et locuti sunt nequi-
tiam : iniquitatem in excelso locuti
sunt.

Posuerunt in cælum os suum : et
lingua eorum transivit in terra.

Ideo convertetur populus meus hic : revertetur huc
et dies pleni invenientur in eis.

prayer to be offered day by day through all ages ; and by Him is the earth blessed with "an heap of corn," the "Bread of Life," to be the sustenance of His people here, and until the time when "His fruit shall shake like Libanus" in the Tree of Life, and be "green in the midst of the street of" the New Jerusalem.

The doxology of this Psalm forms to it a fitting conclusion of fervent praise, but it also marks the end of the second book of Psalms ; in which it may be observed that the Church, as the Mystical Body of Christ, has been more prominently brought forward than in the first book.

THE THIRD BOOK.

PSALM LXXIII.

As our Lord Jesus increased in wisdom as well as in stature [Luke ii. 52], it must be concluded that the fulness of knowledge did not at once come to His Human Nature, notwithstanding its

union with His Omniscient Divine Nature. It is not, therefore, irreverent to suppose that some actual condition of our Lord's mind is predicted in this Psalm ; and that there was a period in His life when the vision of a Divine Providence was in some degree veiled from His sight, as at last was the Vision of the Divine Presence.

Another view that may be taken is, that, as the Penitential Psalms are the words of Christ speaking for and in His sinful members, so these are His words speaking for and in those whose eyes behold things darkly, so that "men" seem "as trees walking," until His word causes them to see clearly, and His unveiled Presence reveals the mysteries of His hidden Providence.

The twenty-first chapter of Job is very similar in character to the seventy-third Psalm, and it is one of the many striking and instructive coincidences brought out by the daily services of the sanctuary that on the 14th of June the one is the first lesson at Mattins, the other an Evensong Psalm. This coincidence is not the less striking because of the manner in which Job, as well as David, was so conspicuous a type of our Blessed Lord : for it

The XIV. Day. Evening Prayer. Job xxi. 15.	11 Tush, say they; how should God perceive it : is there knowledge in the most High ?	Et dixerunt, Quomodo scit Deus : et si est scientia in Excelso ?
	12 Lo, these are the ungodly, these prosper in the world, and these have riches in possession : and I said, Then have I cleansed my heart in vain, and washed mine hands in innocency.	Ecce ipsi peccatores, et abundantes in sæculo : obtinuerunt divitias. Et dixi, Ergo sine causa justificavi cor meum : et lavi inter innocentes manus meas :
Luke xvi. 20.	13 All the day long have I been punished : and chastened every morning.	Et fui flagellatus tota die : et castigatio mea in matutinis. <small>et index meus in mat.</small>
Isa. liii. 8-10.	14 Yea, and I had almost said even as they : but lo, then I should have condemned the generation of thy children.	Si dicebam, Narrabo sic : ecce natio filiorum tuorum quibus disposui tionem filiorum tuorum reproboavi.
	15 Then thought I to understand this : but it was too hard for me,	Existimabam ut cognoscerem : hoc labor est ante me.
1 Cor. xiii. 12.	16 Until I went into the sanctuary of God : then understood I the end of these men ;	Donec intrem in sanctuarium Dei : et intelligam in novissimis eorum. <small>novissima</small>
	17 Namely, how thou dost set them in slippery places : and castest them down, and destroyest them.	Veruntamen propter dolos posuisti eis : dejecisti eos dum alleventur. <small>disposuisti</small>
Job xxi. 13. Luke xvi. 23. xii. 20.	18 Oh, how suddenly do they consume : perish, and come to a fearful end !	Quomodo facti sunt in desolationem ? subito defecerunt : perierunt propter iniquitatem suam.
	19 Yea, even like as a dream when one awaketh : so shalt thou make their image to vanish out of the city.	Velut somnium surgentium, Domine : in civitate tua imaginem ipsorum ad nihilum rediges. <small>a somno exurgentes . . . imagines eorum</small>
	20 Thus my heart was grieved : and it went even through my reins.	Quia inflammatum est cor meum, et renes mei commutati sunt : et ego ad nihilum redactus sum et nescivi. <small>delectatum est cor resoluti sunt</small>
	21 So foolish was I, and ignorant : even as it were a beast before thee.	Ut jumentum factus sum apud te : et ego semper tecum.
Heb. xii. 7.	22 Nevertheless, I am alway by thee : for thou hast holden me by my right hand.	Tenuisti manum dexteram meam, et in voluntate tua deduxisti me : et cum gloria suscepisti me. <small>adsumpsisti me</small>
Heb. xii. 2.	23 Thou shalt guide me with thy counsel : and after that receive me with glory.	Quid enim mihi est in cælo ? et te quid volui super terram ? <small>a restati in cælo</small>
1 Cor. ii. 9.	24 Whom have I in heaven but thee : and there is none upon earth that I desire in comparison of thee.	Defecit caro mea et cor meum : Deus cordis mei et pars mea Deus in æternum. <small>in sæcula</small>
	25 My flesh and my heart faileth : but God is the strength of my heart, and my portion for ever.	

illustrates the principle laid down by Christ that the Scriptures speak in every page concerning Him. It was true of Him in the most literal sense that while the ungodly were prospering in the world and had great riches in possession, He was punished all the day long, chastened every morning, and without a place where to lay His Head.

There are few portions of Holy Scripture which offer so much consolation to the Church of Christ, or to individual Christians in time of affliction and depression. The powers of wickedness

have often seemed to be prevailing, and God's purposes to be failing; prosperity has often seemed to follow the footsteps of vice, and misery that of virtue: but this is only a superficial and short-sighted view of things, which may be corrected by "going into the sanctuary of God," and looking at the eternal life of mankind as the true life. Then it will be found, that, though Antichrist and his ministers may prevail for a time, Christ and His Church shall reign for ever and ever; and that though wicked Dives may have his good things and holy Lazarus

The XIV. Day. 26 For lo, they that forsake thee
Evening shall perish : thou hast destroyed all
Prayer. them that commit fornication against
Rev. xviii. 3. 9. thee.

Heb. x. 36. 27 But it is good for me to hold me
2 Kings xix. 21. fast by God, to put my trust in the
Lord God : and to speak of all thy
works in the gates of the daughter of
Sion.

THE LXXIV PSALM.

Ut quid, Deus.

Rev. vi. 10. **O** GOD, wherefore art thou absent
from us so long : why is thy
wrath so hot against the sheep of thy
pasture ?

Deut. ix. 29. 2 O think upon thy congregation :
Exod. xv. 16. whom thou hast purchased and re-
1 Cor. vi. 20. deemed of old.

Gen. xlix. 10. 3 Think upon the tribe of thine in-
Heb. vii. 14. heritance : and mount Sion, wherein
thou hast dwelt.

4 Lift up thy feet, that thou mayest
utterly destroy every enemy : which
hath done evil in thy sanctuary.

2 Thess. ii. 4. 5 Thine adversaries roar in the
Rev. xiii. 16. midst of thy congregations : and set
up their banners for tokens.

6 He that hewed timber afore out
of the thick trees : was known to bring
it to an excellent work.

1 Kings vi. 29. 7 But now they break down all the
2 Kings xxv. 13. carved work thereof : with axes and
hammers.

2 Kings xxv. 9. 8 They have set fire upon thy holy
Jer. lii. 13. places : and have defiled the dwelling-
place of thy Name, even unto the
ground.

9 Yea, they said in their hearts,
Let us make havock of them altoge-
ther : thus have they burnt up all the
houses of God in the land.

Quia ecce, qui elongant se a te peri-
bunt : perdidisti omnes qui fornicantur *perdas*
abs te.

Mihi autem adhærere Deo bonum
est : ponere in Domino Deo spem
meam :

Ut annuntiem omnes prædicationes *laud-s tuas*
tuas : in portis filiæ Sion.

PSALMUS LXXIII.

UT quid, Deus, repulisti in finem : Thursd. Mattins.
iratus est furor tuus super oves Maundy Thursd.,
pascuæ tuæ ? 2nd Noct.
gregis tuæ

Memor esto congregationis tuæ :
quam possedisti ab initio. *creasti*

Redemisti virgam hæreditatis tuæ : *Liberasti . . . ha-*
mons Sion, in quo habitasti in eo. *bitas in idipso*

Leva manus tuas in superbias eorum
in finem : quanta malignatus est ini-
micus in sancto.

Et gloriati sunt qui oderunt te : in *in medio atrio tuo*
medio solennitatis tuæ.

Posuerunt signa sua, signa : et non
cogoverunt sicut in exitu super sum- *in via supra*
mum.

Quasi in silva lignorum securibus
exciderunt januas ejus in idipsum : in
securi et ascia dejecerunt eam. *bipenne et*

Incenderunt igni sanctuarium tuum
in terra : polluerunt tabernaculum No-
minis tui.

Dixerunt in corde suo cognatio
eorum simul : Quiescere *eorum inter se*
omnes dies festos Dei a terra. *Ventile compri-*
mamus omnes

lis evil things in this world, yet hereafter the prosperous sinner
will be tormented and the afflicted saint comforted.

As yet we cannot understand these mysteries of Providence any
more than we can understand the mysteries of God's Personality
and Trinity ; though we know as much as this, that Christ Him-
self was chastened, and was made perfect through sufferings, and
that "if ye endure chastening, God dealeth with you as with sons."
Hereafter, they who obtain an entrance into the eternal sanctuary
of the Heavenly Jerusalem will understand these things. Man
once endeavoured prematurely to attain such fulness of knowledge
and to "be as God:" hereafter "we shall be like Him" in our
degree, even in the understanding of His Providential acts : no
longer looking upon Him darkly as through a glass, but seeing
"Him as He is," perfect in justice, love, and truth. [1 John iii. 2.]

PSALM LXXIV.

This wailing lamentation belongs either historically or pro-
phetically to the period when God's Presence had been removed
from Zion during the time of the Babylonish Captivity¹. It is

¹ It is a mistake to consider this Psalm as applicable to the destruction
of the Temple by the Romans under Titus. When this event occurred, the
Presence of God had been removed from the Temple to the Church. The
Spirit of God, speaking by St. Paul, declared that however glorious the Old
Dispensation was, the New Dispensation far exceeded it in glory. The
same Spirit, speaking by the Psalmist, would not have lamented the pass-
ing away of that Old Dispensation in such terms as are here used. But
such terms are quite natural in respect to the temporary destruction of a
system which was not yet permanently replaced by a better.

The XIV. Day. <i>Evening</i> <i>Prayer.</i> Dan. xi. 31. Job xxi. 20.	10 We see not our tokens, there is not one prophet more : no, not one is there among us, that understandeth any more.	Signa nostra non vidimus, jam non est propheta : et nos non cognoscet amplius.
	11 O God, how long shall the adversary do this dishonour : how long shall the enemy blaspheme thy Name, for ever ?	Usquequo, Deus, improperebit inimicus : irritat adversarius Nomen tuum in finem ?
Cf. Prov. xxvi. 15.	12 Why withdrawest thou thy hand : why pluckest thou not thy right hand out of thy bosom to consume the enemy ?	Ut quid avertis manum tuam : et dexteram tuam de medio sinu tuo in finem ?
	13 For God is my King of old : the help that is done upon earth he doeth it himself.	Deus autem Rex noster ante sæcula : operatus est salutem in medio terræ.
Gen. iii. 15. Matt. xxviii. 19.	14 Thou didst divide the sea through thy power : thou brakest the heads of the dragons in the waters.	Tu confirmasti in virtute tua mare : contribulasti capita draconum in aquis.
Rev. xix. 17.	15 Thou smotest the heads of Leviathan in pieces : and gavest him to be meat for the people in the wilderness.	Tu confregisti capita draconis : disti eum escam populis Æthiopum.
Zech. xiii. 1. John iv. 14. Rev. vii. 17. xii. 16.	16 Thou broughtest out fountains and waters out of the hard rocks : thou driedst up mighty waters.	Tu dirupisti fontes et torrentes : tu siccasti fluvios Ethan.
John i. 9. Mal. iv. 2.	17 The day is thine, and the night is thine : thou hast prepared the light and the sun.	Tuus est dies, et tua est nox : tu fabricatus es auroram et solem.
	18 Thou hast set all the borders of the earth : thou hast made summer and winter.	Tu fecisti omnes terminos terræ : æstatem et ver tu plasmasti ea.
Rev. xiii. 1. 6.	19 Remember this, O Lord, how the enemy hath rebuked : and how the foolish people hath blasphemed thy Name.	Memor esto hujus, inimicus impropavit Domino : et populus insipiens incitavit Nomen tuum.
	20 O deliver not the soul of thy turtle-dove unto the multitude of the enemies : and forget not the congregation of the poor for ever.	Ne tradas bestiis animas confitentes tibi : et animas pauperum tuorum ne obliviscaris in finem.
Jer. xxxi. 31.	21 Look upon the covenant : for all the earth is full of darkness, and cruel habitations.	Respice in testamentum tuum : quia repleti sunt qui obscurati sunt terræ domibus iniquitatum.
	22 O let not the simple go away ashamed : but let the poor and needy give praise unto thy Name.	Ne avertatur humilis factus confusus : pauper et inops laudabunt Nomen tuum.

not, however, the lamentation of penitents, like the prayer of Daniel (which in some respects corresponds with this Psalm), but of the Church speaking by her Head. Hence there is no trace of such words as those of Daniel, *Yea, all Israel have transgressed Thy law . . . therefore the curse is poured upon us.* [Dan. ix. 11.] The one thought which pervades the Psalm is that of the dishonour done to God by the desolation of His holy House; and the cry goes up to His Throne, "How long shall the Adversary do this dishonour? . . . Maintain Thine own cause." It is not the *sinner* who speaks, pleading, "O Lord, hear; O Lord, forgive; O Lord, hearken and do: defer not, for Thine own sake, O my God;

for Thy city and Thy people are called by Thy Name." [Dan. ix. 19.] But it is the Voice of Him Who cried, "Father, glorify Thy Name."

This literal application of it to the Captivity, and the destruction of Solomon's Temple, is sufficiently evident; and it is only necessary to point out that Christ seems already to be pleading for His Church even before the Dispensation of Sinai had given place to that of the Incarnation. It is far more clear, however, that the Psalm represents Him as pleading for the New Jerusalem in times of depression, affliction, and persecution: and especially in that time of desolation of which He Himself prophesied

The XIV. Day. **23** Arise, O God, maintain thine
Evening Prayer. own cause : remember how the fool-
ish man blasphemeth thee daily.

24 Forget not the voice of thine
enemies : the presumption of them
that hate thee increaseth ever more
and more.

THE LXXV PSALM.

Confitebimur tibi.

The XV. Day. **U**NTO thee, O God, do we give
Morning Prayer. thanks : yea, unto thee do we
give thanks.

*Cf. Song of Han-
nah, 1 Sam. ii.
1-10, and the
Magnificat.*

2 Thy Name also is so high : and
that do thy wondrous works declare.

*Luke xxii. 30.
1 Cor. vi. 2.*

3 When I receive the congregation :
I shall judge according unto right.

4 The earth is weak, and all the
inhabiters thereof : I bear up the
pillars of it.

*2 Thess. ii. 4.
Rev. xiii. 6. 8.*

5 I said unto the fools, Deal not so
madly : and to the ungodly, Set not
up your horn.

6 Set not up your horn on high :
and speak not with a stiff neck.

*[Cf. Dan. viii. 6.
9. xi. passim.
Rev. xvi. 12.]*

7 For promotion cometh neither
from the east, nor from the west :
nor yet from the south.

*2 Kings xix. 25,
26.
Rev. xiii. 7.*

8 And why? God is the Judge :
he putteth down one, and setteth up
another.

Rev. xiv. 10.

9 For in the hand of the Lord there
is a cup, and the wine is red : it is full
mixed, and he poureth out of the same.

Rev. xvi. 19.

10 As for the dregs thereof : all the
ungodly of the earth shall drink them,
and suck them out.

Rev. xix. 1.

11 But I will talk of the God of
Jacob : and praise him for ever.

*Rev. xvii. 3. 16.
xv. ii. 2.
v. 6.*

12 All the horns of the ungodly also
will I break : and the horns of the
righteous shall be exalted.

Exsurge, Deus, judica causam tuam
memor esto impropiorum tuorum,
eorum quæ ab insipiente sunt tota die.

Ne obliviscaris voces inimicorum
tuorum : superbia eorum qui te ode-
runt ascendit semper

*voces quarentium
te*

*ascendat semper
ad te*

PSALMUS LXXIV.

CONFITEBIMUR tibi, Deus, con-
fitebimur : et invocabimus Nomen
tuum.

*Thursd. Mattins.
Maundy Thursd.
App. and Evv.,
3rd Noct.*

Narrabimus mirabilia tua : cum ac-
cepero tempus, ego justitias judicabo.

Narrabo omnia

Liquefacta est terra et omnes qui
habitant in ea : ego confirmavi colum-
nas ejus.

Dixi iniquis, Nolite inique agere : et
delinquentibus, Nolite exaltare cornu.

Nolite extollere in altum cornu ves-
trum : nolite loqui adversus Deum ini-
quitatem.

Quia neque ab oriente, neque ab
occidente, neque a desertis montibus :
quoniam Deus judex est.

Hunc humiliat et hunc exaltat : quia
calix in manu Domini vini meri plenus
mixto.

Et inclinavit ex hoc in hoc ; verunta-
men fæx ejus non est exinanita : bibent
omnes peccatores terræ.

bibent ex eo

Ego autem annuntiabo in sæculum :
cantabo Deo Jacob.

in sæcula gaudebo

Et omnia cornua peccatorum confrin-
gam : et exaltabuntur cornua justi.

as to happen in the last days. No human words can heighten the awful horror of the picture drawn by our Lord in Matt. xxiv., and by St. John in Rev. xiii. 8, in which both are setting forth the final attempt of the Adversary to dishonour God by destroying His Church ; and to that period, doubtless, belongs the full force of this Psalm.

But every opposition offered to the true work of Christ's Church, is an approach towards that height of blasphemy and persecution which will characterize that period. In respect to all such trouble, therefore, the Church continually sings this supplicatory hymn, beseeching the Lord to "maintain His own cause."

PSALM LXXV.

This is a song of triumphant hope sung by the Church of God in prospect of the final contest with Antichrist : sung, not as by

a human community, but as by the Mystical Body of Christ ; and, therefore, as by Christ Himself speaking, in and by His Church.

The "Name" of God is brought "so nigh" to man through the Incarnation of the second Person in the Blessed Trinity, and evidence of its nighness is given by all the wondrous works which have been done in the kingdom which Christ appointed to His Church as His Father had appointed unto Him. [Luke xxii. 29.] Though, therefore, the earth is weak (or "poured out" in weakness), yet does Christ, by His Presence in the Church, "bear up the pillars of it," and establish His Kingdom as "a city which cannot be moved." Hence the folly of those who oppose and seek to overthrow the Church of Christ ; a folly which will culminate in the mad and terrible violence of the great Antichrist who will be "revealed in his time," the "Ungodly," who sets up his horn

THE LXXVI PSALM.

Notus in Judæa.

The XV. Day. **I**N Jewry is God known : his Name
Morning
Prayer.
is great in Israel.

Gen. xiv. 18.
Heb. vii. 2.
2 At Salem is his tabernacle : and
his dwelling in Sion.

2 Kings xix. 35.
Rev. xix. 15, 20.
3 There brake he the arrows of the
bow : the shield, the sword, and the
battle.

Rev. xvii. 9.
xiv. 1.
4 Thou art of more honour and
might : than the hills of the robbers.

5 The proud are robbed, they have
slept their sleep : and all the men
whose hands were mighty have found
nothing.

6 At thy rebuke, O God of Jacob :
both the chariot and horse are fallen.

7 Thou, even thou art to be feared :
and who may stand in thy sight when
thou art angry ?

Rev. xvi. 18.
xx. 11.
8 Thou didst cause thy judgement
to be heard from heaven : the earth
trembled, and was still,

9 When God arose to judgement :
and to help all the meek upon earth.

10 The fierceness of man shall turn
to thy praise : and the fierceness of
them shalt thou refrain.

Rev. xxi. 24.
11 Promise unto the Lord your God,
and keep it, all ye that are round about
him : bring presents unto him that
ought to be feared.

Rev. xxi. 25.
12 He shall refrain the spirit of
princes : and is wonderful among the
kings of the earth.

PSALMUS LXXV.

NOTUS in Judæa Deus : in Israëli
magnum Nomen ejus. Thursd. Mattins.
Maundy Thursd.,
Easter Eve,
3rd Noct.

Et factus est in pace locus ejus : et
habitatio ejus in Sion.

Ibi confregit potentias : arcum, scu- confregit cornua
tum, gladium et bellum.

Illuminans tu mirabiliter a montibus Illuminas tu
æternis : turbati sunt omnes insipientes
corde.

Dormierunt somnum suum : et nihil
invenerunt omnes viri divitiarum in
manibus suis.

Ab increpatione tua Deus Jacob :
dormitaverunt qui ascenderunt equos.

Tu terribilis es et quis resistet tibi ?
ex tunc ira tua.

De cælo auditum fecisti judicium : judicium jacula-
terra tremuit et quievit, tum est terra

Cum exurgeret in judicio Deus : ut
salvos faceret omnes mansuetos terræ. quietos

Quoniam cogitatio hominis confite-
bitur tibi : et reliquæ cogitationis diem
festum agent tibi.

Vovete et reddite Domino Deo ves-
tro : omnes qui in circuitu ejus affertis
munera,

Terribili, et ei qui aufert spiritum
principum : terribili apud reges terræ.

on high by offering himself as an object of worship instead of Christ, and speaking blasphemous things against the Most Highest. As God "brought it to pass" and not Sennacherib himself, that the Assyrian king should "be to lay waste fenced cities into ruinous heaps," so it is God also by Whom it will be "given unto" Antichrist "to make war with the saints, and to overcome them," for some good purpose towards His Church, doubtless its purgation by persecution.

There may be some reverent hesitation in interpreting the ninth verse without any reference to the Blessed Sacrament : yet it seems to be in strict analogy with two passages in the Revelation, in which "the wine of the wrath of God," and "the cup of His indignation" is given to the worshippers of Antichrist, and to "great Babylon." And this sense seems to be confirmed by the undoubted reference in the last verse to the triumph of "the Lamb as it had been slain, having seven horns and seven eyes, which are the seven spirits of God," over both Antichrist and Babylon.

PSALM LXXVI.

As the preceding Psalm is a prophetic hymn of Christ's Mystical Body looking forward to the onslaught of Antichrist, so in

this still higher strain of triumph is to be discerned the celebration of a victory accomplished. The Septuagint title describes it as sung respecting the Assyrian, doubtless after the destruction of Sennacherib's host : and, like the former Psalm, this also is to be regarded as a hymn of victory over that Antichrist of whom Sennacherib was one of the many personal types. It is very significant that the City of God is spoken of under the name of Salem, not Jerusalem ; the former being the name which it bore in the time of Melchizedec, after the order of whose Priesthood Christ came, Whose undisputed reign alone will establish a City of perfect Peace¹. [Rev. vi. 4. Isa. ii. 4. Micah iv. 3.]

This may be taken, therefore, as an Evangelical hymn of that new Jewry, Salem, and Sion, of which St. John heard the "great voice out of Heaven, saying, Behold, the tabernacle of God is with men, and He will dwell with them, and they shall be His people, and God Himself shall be with them, and be their God. And God shall wipe away all tears from their eyes ; and there shall be no more death, neither sorrow, nor crying, neither shall there be any more pain, for the former things are passed away." [Rev. xxi. 3, 4.] The troubles of the last days are spoken of as

¹ The LXX translates the Hebrew "ἐν εἰρήμῃ."

THE LXXVII PSALM.

Voce mea ad Dominum.

The XV. Day.
Morning
Prayer.
Isa. lviii. 9.

I WILL cry unto God with my voice : even unto God will I cry with my voice, and he shall hearken unto me.

Isa. xxxviii. 2.

2 In the time of my trouble I sought the Lord : my sore ran, and ceased not in the night-season ; my soul refused comfort.

3 When I am in heaviness, I will think upon God : when my heart is vexed, I will complain.

4 Thou holdest mine eyes waking : I am so feeble, that I cannot speak.

Rom. xv. 4.
1 Cor. x. 11.

5 I have considered the days of old : and the years that are past.

6 I call to remembrance my song : and in the night I commune with mine own heart, and search out my spirits.

7 Will the Lord absent himself for ever : and will he be no more intreated ?

8 Is his mercy clean gone for ever : and is his promise come utterly to an end for evermore ?

Isa. lix. 1.

9 Hath God forgotten to be gracious : and will he shut up his loving-kindness in displeasure ?

Matt. viii. 26.

10 And I said, It is mine own infirmity : but I will remember the years of the right hand of the most Highest.

Isa. lxiii. 7.

11 I will remember the works of the Lord : and call to mind thy wonders of old time.

12 I will think also of all thy works : and my talking shall be of thy doings.

13 Thy way, O God, is holy : who is so great a God as our God ?

Exod. xv. 11.

14 Thou art the God that doest wonders : and hast declared thy power among the people.

PSALMUS LXXVI.

VOCE mea ad Dominum clamavi : Thursd. Mattins.
Maundy Thursd.,
3rd Noct.
voce mea ad Deum, et intendit mihi.

In die tribulationis meae Deum exquisivi, manibus meis nocte contra eum : et non sum deceptus. coram eo

Renuit consolari anima mea : memor fui Dei, et delectatus sum, et exercitatus sum ; et defecit spiritus meus. Negavi . . . animam meam paulisper spiritus

Anticipaverunt vigilias oculi mei : turbatus sum et non sum locutus.

Cogitavi dies antiquos : et annos æternos in mente habui.

Et meditatus sum nocte cum corde meo : et exercitabar et scopebam spiritum meum. et ventilabam in me

Nunquid in æternum projiciet Deus : aut non apponet ut complacitior sit adhuc ? Et disci numquid ut bene placitum sit

Aut in finem misericordiam suam abscindet : a generatione in generationem ? a sæculo et generatione

Aut obliviscetur misereri Deus ? aut continebit in ira sua misericordias suas ?

Et dixi, Nunc cœpi : hæc mutatio dexteræ Excelsi.

Memor fui operum Domini : quia memor ero ab initio mirabilium tuorum.

Et meditabor in omnibus operibus tuis : et in adinventionibus tuis exercabor. meditatus sum observationibus

Deus, in sancto via tua ; quis Deus magnus sicut Deus noster ? tu es Deus qui facis mirabilia. mirabilia solus

past ; Antichrist is subdued and overthrown ; the judgment of Christ has been heard from the "great white throne ;" the perfect supremacy of the "King of kings and Lord of lords" is for ever established in an endless reign of peace.

PSALM LXXVII.

In the first half of this Psalm the voice of Christ's Mystical Body cries out to God from the midst of some affliction in which He has seemed to hide His face. The tenth versè recalls to mind that God is never really absent from the Church, and that if He

seems to be so it is because our own infirmity and want of faith prevent us from beholding His Presence. In the latter half of the Psalm God's dealings with His people of old are recounted as a memorial before Him in the tone of the Litany Antiphon :—"O Lord, arise, help us, and deliver us for Thy Name's sake."

There were occasions on which the way of Christ was "in the sea, and His path in the deep waters ;" and when "the waters saw" Him their God "and were afraid, and the depths were troubled ;" and these miracles of our Lord's Person and Word seem to be prophetically commemorated in this Psalm no less

The XV. Day.
Morning Prayer.
Cf. Ps. lxxx. 2, 3.
15 Thou hast mightily delivered thy people : even the sons of Jacob and Joseph.

Exod. xiv. 21.
Matt. viii. 26.
16 The waters saw thee, O God, the waters saw thee, and were afraid : the depths also were troubled.

2 Sam. xxii. 14.
Josh. x. 11.
2 Sam. xxii. 15.
17 The clouds poured out water, the air thundered : and thine arrows went abroad.

18 The voice of thy thunder was heard round about : the lightnings shone upon the ground, the earth was moved, and shook withal.

Mark vi. 48.
Rom. xi. 33.
19 Thy way is in the sea, and thy paths in the great waters : and thy footsteps are not known.

20 Thou leddest thy people like sheep : by the hand of Moses and Aaron.

THE LXXVIII PSALM.

Attendite, popule.

Evening Prayer.
Isa. li. 4.
HEAR my law, O my people : incline your ears unto the words of my mouth.

Matt. xiii. 35.
1 Cor. x. 11.
2 I will open my mouth in a parable : I will declare hard sentences of old ;

Exod. xii. 14.
Deut. vi. 20.
3 Which we have heard and known : and such as our fathers have told us ;

Coloss. i. 27.
4 That we should not hide them from the children of the generations to come : but to shew the honour of the Lord, his mighty and wonderful works that he hath done.

Deut. iii. 13.
Heb. viii. 8.
Deut. iii. 7.
5 He made a covenant with Jacob, and gave Israel a law : which he commanded our forefathers to teach their children ;

Notam fecisti in populis virtutem tuam : redemisti in brachio tuo populum tuum, filios Jacob et Joseph. *liberasti*

Viderunt te aquæ, Deus, viderunt te aquæ et timuerunt : et turbatæ sunt abyssi.

Multitudo sonitus aquarum : vocem dederunt nubes.

Etenim sagittæ tuæ transeunt : vox tonitruui tui in rota.

Illuxerunt coruscationes tuæ orbi terræ : commota est et contremuit terra. *vidit et commota est terra*

In mari via tua, et semitæ tuæ in aquis multis : et vestigia tua non cognoscentur.

Deduxisti sicut oves populum tuum : in manu Moysi et Aaron.

PSALMUS LXXVII.

ATTENDITE, popule meus, legem meam : inclinate aurem vestram in verba oris mei. *Thursd. Mattins.*

Aperiam in parabolis os meum : loquar propositiones ab initio. *initio sæculi*

Quanta audivimus et cognovimus ea : et patres nostri narraverunt nobis.

Non sunt occultata a filiis eorum : in generatione altera.

Narrantes laudes Domini et virtutes ejus : et mirabilia ejus quæ fecit.

Et suscitavit testimonium in Jacob : et legem posuit in Israël.

than the miraculous passage of the Red Sea is historically commemorated. On one of these occasions the storm arose when our Lord was asleep in the ship, and after being awoke He expressly rebuked the disciples for their want of faith, reminding them that their fear arose from their "own infirmity," for that His Presence not less than His Word is a sure token of safety to the Church. On the other occasion our Lord walked on the sea to the disciples who were toiling in vain against a contrary wind, and they were by His Presence brought immediately to the haven where they would be. Then, too, it is recorded of them that their faith was wanting, "for they considered not the miracle of the loaves : for their heart was hardened."

Thus the key-note of the Psalm is struck in the tenth verse. Adversity may surround the Church or particular members of it, and Christ's Presence may seem far off, or if He is in the ship yet is He asleep ; faith, however, will say, This appearance of danger is from "mine own infirmity, but I will remember the years of the right hand of the most Highest." Though we may

be in the midst of "the waves of this troublesome world" and He on the shore of His Father's Throne, yet is His way in the sea, and His path in the great waters ; so that nothing can separate the Church from the protection of His Presence. Though He may seem to be heedless of our danger yet may we rely on His Presence and be sure that if He is in the ship, though asleep, it is an Ark of safety.

Very great comfort may therefore be found in this Psalm at all times of tribulation, for in it we memorialize God, and remind ourselves, of His wonders to His Church in old time, and of His never-failing love towards her for ever. As He led His ancient people like sheep by the hand of Moses and Aaron, so does He Himself as the Good Shepherd go before His sheep that they may hear His voice, and follow Him to pastures of safety and peace.

PSALM LXXVIII.

This didactic hymn sets forth the history of the ancient Israel as in a parable for the instruction of the new Israel of God, and

The XV. Day. <i>Evening Prayer.</i>	6 That their posterity might know it : and the children which were yet unborn ;	Quanta mandavit patribus nostris : <small>Quam . . . ut notam faceret ea</small> nota facere ea filiis suis ; ut cognoscat generatio altera ;
Deut. vi. 20.	7 To the intent that when they came up : they might shew their children the same ;	Fili qui nascentur et exsurgent : et narrabunt filiis suis.
	8 That they might put their trust in God : and not to forget the works of God, but to keep his commandments ;	Ut ponant in Deo spem suam : et non obliviscantur operum Dei ; et mandata ejus exquirant.
Deut. xxi. 18. Acts vii. 51. 2 Chron. xxx. 7.	9 And not to be as their forefathers, a faithless and stubborn generation : a generation that set not their heart aright, and whose spirit cleaveth not stedfastly unto God ;	Ne fiant sicut patres eorum : generatio prava et exasperans. <small>genus pravum et peramarum</small>
	et non est creditus cum Deo spiritus ejus.	Generatio quæ non direxit cor suum : <small>Genus quod</small>
Hosea x. 13.	10 Like as the children of Ephraim : who being harnessed, and carrying bows, turned themselves back in the day of battle.	Fili Ephrem intendentes et mittentes arcum : conversi sunt in die belli. <small>intendentes ar- cum et mit- tentes sagittas suas</small>
2 Kings xvii. 14. Isa. i. 8.	11 They kept not the covenant of God : and would not walk in his law ;	Non custodierunt testamentam Dei : et in lege ejus noluerunt ambulare.
	12 But forgot what he had done : and the wonderful works that he had shewed for them.	Et obliti sunt benefactorum ejus : et mirabilium ejus quæ ostendit eis.
Numb. xiii. 22. Isa. xxx. 3, 4.	13 Marvellous things did he in the sight of our forefathers, in the land of Egypt : even in the field of Zoan.	Coram patribus eorum fecit mirabilia in terra Ægypti : in campo Thaneos.
Exod. xiv. 1. 1 Cor. xi. 2.	14 He divided the sea, and let them go through : he made the waters to stand on an heap.	Interruptit mare et perduxit eos : et statuit aquas quasi in utre.
Exod. xiii. 21. Isa. iv. 5.	15 In the day-time also he led them with a cloud : and all the night through with a light of fire.	Et deduxit eos in nube diei : et tota nocte in illuminatione ignis.
Exod. xvii. 6. Numb. xx. 11. 1 Cor. x. 4.	16 He clave the hard rocks in the wilderness : and gave them drink thereof ; as it had been out of the great depth.	Interruptit petram in eremo : et adaquavit eos velut in abyssio multa.
	17 He brought waters out of the stony rock : so that it gushed out like the rivers.	Et eduxit aquam de petra : et deduxit tanquam flumina aquas.
Heb. iii. 16.	18 Yet for all this they sinned more against him : and provoked the most Highest in the wilderness.	Et apposuerunt adhuc peccare ei : in iram concitaverunt Excelsum in inaquoso. <small>Deum excelsum in siccitate</small>
Exod. xvi. 3.	19 They tempted God in their hearts : and required meat for their lust.	Et tentaverunt Deum in cordibus suis : ut peterent escas animabus suis.

for memorializing Him of His mercies to the Church of all ages. As regards the Jews it has a parallel in the discourse of St. Stephen before the Council of the Sanhedrim, especially in setting forth the persistent disobedience to God by which their history had been marked, and the continual forgiveness with which He had requited their misdeeds. That the parable is spoken with reference to the Christian Church also we may clearly understand from the words with which St. Paul concludes a short enumeration of some of the sins of Israel:—

“Now all these things happened unto them for ensamples, and they are written for our admonition, upon whom the ends of the world are come¹.” The Psalm, therefore, comes to the Church as the voice of Christ, saying, “Hearken unto Me, My people, and give ear unto Me, O My nation ; for a law shall proceed from Me, and I will make My judgment to rest for a light of

¹ It has been observed as illustrating the typical force of this Psalm, that though relating to past events the Hebrew verbs are in the future.

The XV. Day. Evening Prayer. John vi. 52. 60.	20 They spake against God also, saying : Shall God prepare a table in the wilderness ?	Et male locuti sunt de Deo : dixerunt, Nunquid poterit Deus parare mensam in deserto ?
Numb. xi. 4. 22.	21 He smote the stony rock indeed, that the water gushed out, and the streams flowed withal : but can he give bread also, or provide flesh for his people ?	Qui percussit petram, et fluxerunt aquæ : et torrentes inundaverunt : Nunquid et panem poterit dare : aut parare mensam populo suo ?
Numb. xi. 1.	22 When the Lord heard this, he was wroth : so the fire was kindled in Jacob, and there came up heavy displeasure against Israel ;	Ideo audivit Dominus et distulit : et ignis accensus est in Jacob, et ira ascendit in Israël. <small>et superposuit et ignis</small>
John vi. 32.	23 Because they believed not in God : and put not their trust in his help.	Quia non crediderunt in Deo : nec speraverunt in salutari ejus.
John vi. 32.	24 So he commanded the clouds above : and opened the doors of heaven.	Et mandavit nubibus desuper : et januas cœli aperuit.
John vi. 51.	25 He rained down manna also upon them for to eat : and gave them food from heaven.	Et pluit illis manna ad manducandum : et panem cœli dedit eis.
John vi. 51.	26 So man did eat Angels' food : for he sent them meat enough.	Panem angelorum manducavit homo : cibaria misit eis in abundantia. <small>frumentationem misit</small>
Numb. xi. 31.	27 He caused the east-wind to blow under heaven : and through his power he brought in the south-west-wind.	Transtulit austrum de cœlo : et induxit in virtute sua afriicum. <small>Et excitavit Austrum</small>
	28 He rained flesh upon them as thick as dust : and feathered fowls like as the sand of the sea.	Et pluit super eos sicut pulverem carnes : et sicut arenam maris volatilia pennata.
	29 He let it fall among their tents even round about their habitation.	Et ceciderunt in medio castrorum eorum : circa tabernacula eorum.
	30 So they did eat, and were well filled, for he gave them their own desire : they were not disappointed of their lust.	Et manducaverunt, et saturati sunt nimis, et desiderium eorum attulit eis : non sunt fraudati a desiderio suo.
Numb. xi. 33.	31 But while the meat was yet in their mouths, the heavy wrath of God came upon them, and slew the wealthiest of them : yea, and smote down the chosen men that were in Israel.	Adhuc escæ eorum erant in ore ipsorum : et ira Dei ascendit super eos.
Numb. xii. 2.	32 But for all this they sinned yet more : and believed not his wondrous works.	Et occidit pingues eorum : et electos Israël impedivit. <small>plurimos eorum</small>
	33 Therefore their days did he consume in vanity : and their years in trouble.	In omnibus his peccaverunt adhuc : et non crediderunt in mirabilibus ejus.
2 Chron. xxx. 9.	34 When he slew them, they sought him : and turned them early, and enquired after God.	Et defecerunt in vanitate dies eorum : et anni eorum cum festinatione.
		Cum occideret eos, quærebant eum et revertebantur : et diluculo veniebant ad eum. <small>et convertebantur ante lucem et veniebant</small>

the people. My righteousness is near; My salvation is gone forth; and Mine arm shall judge the people; the isles shall wait upon Me, and on Mine arm shall they trust." "All these things, spake Jesus unto the multitude in parables; and without a parable spake He not unto them."

As it will be impracticable to follow out this typical character of the Psalm in any lengthy detail, a few particulars may be

selected for the purpose of illustration from several of its various sections.

The whole Psalm obviously symbolizes the passage of the new Israel at all periods of its history from spiritual bondage and the wilderness of this world to the promised land of rest and the heavenly Jerusalem. Hence the significance of the fourteenth verse, relating to the Baptism of the Israelites in the cloud and

The XV. Day.
Evening
Prayer.
Deut. xxxii. 4.
15. 18. 30.

35 And they remembered that God was their strength : and that the high God was their Redeemer.

36 Nevertheless, they did but flatter him with their mouth : and dissembled with him in their tongue.

37 For their heart was not whole with him : neither continued they stedfast in his covenant.

Exod. xxxiv. 6.

38 But he was so merciful, that he forgave their misdeeds : and destroyed them not.

Numb. xiv. 22.
Exod. xiv. 11, 12.
xv. 23, 24.
xvi. 2. 20. 27.
28. xvii. 1-3.
xxxii. 8.
Numb. xi. 1. 4.
xiv. 1, 2.

39 Yea, many a time turned he his wrath away : and would not suffer his whole displeasure to arise.

40 For he considered that they were but flesh : and that they were even a wind that passeth away, and cometh not again.

41 Many a time did they provoke him in the wilderness : and grieved him in the desert.

Acts vii. 52.

42 They turned back and tempted God : and moved the Holy One in Israel¹.

43 They thought not of his hand : and of the day when he delivered them from the hand of the enemy ;

44 How he had wrought his miracles in Egypt : and his wonders in the field of Zoan.

Exod. vii. 19, 20.
Rev. xvi. 4. 6.

45 He turned their waters into blood : so that they might not drink of the rivers.

Exod. viii. 24. 6.
Rev. xvi. 13, 14.

46 He sent lice among them, and devoured them up : and frogs to destroy them.

Exod. x. 14.
Rev. ix. 3.

47 He gave their fruit unto the caterpillar : and their labour unto the grasshopper.

Exod. ix. 24.
Rev. xvi. 21.

48 He destroyed their vines with hail-stones : and their mulberry-trees with the frost.

Et rememorati sunt quia Deus ad-
jutor est eorum : et Deus excelsus Re-
demptor eorum est. *liberator*

Et dilexerunt eum in ore suo : et
lingua sua mentiti sunt ei.

Cor autem eorum non erat rectum
cum eo : nec fideles habitati sunt in tes-
tamento ejus. *fides habitata est in
test.*

Ipse autem est misericors et propi-
tius fiet peccatis eorum : et non dis-
perdet eos. *At*

Et abundavit ut averteret iram
suam : et non accendit omnem iram
suam. *multiplicavit*

Et recordatus est quia caro sunt :
spiritus vadens et non rediens.

Quotiens exacerbaverunt eum in
deserto : in iram concitaverunt eum in
inaquoso? *in terra sine aqua*

Et conversi sunt et tentaverunt
Deum : et Sanctum Israël exacerba-
verunt.

Non sunt recordati manus ejus : die
qua redemit eos de manu tribulantis. *liberavit*

Sicut posuit in Ægypto signa sua :
et prodigia sua in campo Thaneos.

Et convertit in sanguinem flumina
eorum : et imbres eorum, ne biberent. *et pluviales aquas*

Misit in eos cynomyiam, et comedit
eos : et ranam, et disperdidit eos. *Immisit in eis
muscam carini-
nam . . . ranam
et exterminavit*

Et dedit ærugini fructus eorum : et
labores eorum locustæ.

Et occidit in grandine vineas eorum :
et moros eorum in pruina.

in the sea at the outset of their journey towards the land of promise, and of all those following verses which set forth God's mercy in providing drink and food for them during the whole period of their wanderings. St. Paul's words respecting these circumstances show that we should much undervalue the true teaching of Holy Scripture if we failed to see their typical meaning : and his immediate reference to the "Cup of Blessing"

¹ It has been pointed out by a modern critic that the latter part of verse 42 is literally they "crossed the Holy One of Israel," a striking prophecy of the manner in which "the Jews filled up the measure of their guilt by tempting God manifest in the flesh amongst them, and by 'crossing' the Holy One of Israel." [Thrupp on the Psalms, ii. 26, note.]

and "the Bread which we break" clearly indicates that this typical meaning looks towards the sacramental life of the Christian Church. While, then, we recount the wonders of old time when God divided the sea to let His ancient people pass through, we recount, also, His continual mercy in causing His new Israel to pass through the waters of Baptism that they may be cleansed from the spiritual defilement of the Egypt out of which He has brought them.

A prophecy of Isaiah also connects this portion of the history of Israel very distinctly with the abiding of the Holy Ghost in the Church. Having spoken of the day when "the Branch of the Lord" shall be beautiful and glorious, and the remnant of Israel "shall be called holy even every one that is written among

The XV. Day. <i>Evening Prayer.</i>	49 He smote their cattle also with hail-stones : and their flocks with hot thunder-bolts.	Et tradidit grandini jumenta eorum : et possessionem eorum igni.
	50 He cast upon them the furiousness of his wrath, anger, displeasure, and trouble : and sent evil angels among them.	Misit in eos iram indignationis suæ : indignationem et iram, et tribulationem ; immissiones per angelos malos.
Exod. ix. 3.	51 He made a way to his indignation, and spared not their soul from death : but gave their life over to the pestilence ;	Viam fecit semitæ iræ suæ, et non pepercit a morte animarum eorum : et jumenta eorum in morte conclusit.
Exod. xii. 27—30.	52 And smote all the first-born in Egypt : the most principal and mightiest in the dwellings of Ham.	Et percussit omne primogenitum in terra Ægypti : primitias omnis laboris eorum in tabernaculis Cham.
Exod. xii. 37.	53 But as for his own people, he led them forth like sheep : and carried them in the wilderness like a flock.	Et abstulit sicut oves populum suum : et perduxit eos tanquam gregem in deserto.
Exod. xiv. 27.	54 He brought them out safely, that they should not fear : and overwhelmed their enemies with the sea.	Et eduxit eos in spe, et non timuerunt : et inimicos eorum operuit mare.
Deut. ix. 1.	55 And brought them within the borders of his sanctuary : even to his mountain which he purchased with his right hand.	Et induxit eos in montem sanctificationis suæ : montem, quem acquisivit dextera ejus.
Deut. xxxi. 3. Josh. xi. 23. xiv. 5. Cf. p. 396 note.	56 He cast out the heathen also before them : caused their land to be divided among them for an heritage, and made the tribes of Israel to dwell in their tents.	Et ejecit a facie eorum gentes : et sorte divisit eis terram in funiculo distributionis.
	57 So they tempted and displeased the most high God : and kept not his testimonies ;	Et habitare fecit in tabernaculis eorum : tribus Israël. <i>Et habitavit in</i>
Hosea vii. 16.	58 But turned their backs, and fell away like their forefathers : starting aside like a broken bow.	Et tentaverunt et exacerbaverunt Deum excelsum : et testimonia ejus non custodierunt.
Judges ii. 11. 13.	59 For they grieved him with their hill-altars : and provoked him to displeasure with their images.	Et averterunt se, et non servaverunt pactum : quemadmodum patres eorum, conversi sunt in arcum pravum. <i>observaverunt (pactum) perversum</i>
2 Kings xvii. 18.	60 When God heard this, he was wroth : and took sore displeasure at Israel. *	In iram concitaverunt eum in colibus suis : et in sculptilibus suis ad æmulationem eum provocaverunt. <i>æmulati sunt eum</i>
1 Sam. i. 3. iii. 1. 3.	61 So that he forsook the tabernacle in Silo : even the tent that he had pitched among men.	Audiuit Deus et sprevit : et ad nihilum redegit valde Israël. <i>nimiſ Israel</i>
		Et repulit tabernaculum Silo : tabernaculum suum ubi habitavit in hominibus.

the living in Jerusalem," the prophet goes on to say that the Lord shall then have "washed away the filth of the daughter of Zion" and purged the blood of Jerusalem "by the spirit of judgment, and the spirit of burning. And the Lord will create upon every dwelling-place upon mount Zion, and upon her assemblies, a cloud and smoke by day, and the shining of a flaming fire by night : for upon all the glory shall be a defence. And there shall be a tabernacle for a shadow in the day time from the heat, and for a place of refuge, and for a covert from storm and from rain." [Isa. iv. 2—6.] Thus the cloudy pillar of the Psalm clearly typifies that cloud by which the house was filled where the Apostles were assembled, and which first signified to the Church the coming of the Holy Ghost to abide with it for ever.

Led by the same inspired teaching we know that the rock which God "clave" in the wilderness is a type of Christ the "Rock of ages," and in the continual provision of water from that fountain we thus see a type of that ever-flowing Fountain which has been opened for us in the grace of our Lord, the "living water" of which men drink here as a foretaste of the water of life provided for them in the glorified City of God.

We have still higher authority, if it were possible, that of Christ's own words in the sixth chapter of St. John's Gospel, for taking the Manna of the wilderness as a significant type of the "Living Bread" of the Church. This has been already referred to in the Introduction to the Liturgy [p. 161], but a word may be added as to the significance of the twentieth and

The XV. Day.

*Evening**Prayer.*

Judges ii. 14—23.

1 Sam. iv. 17.

1 Sam. iv. 10.

62 He delivered their power into captivity : and their beauty into the enemy's hands.

63 He gave his people over also unto the sword : and was wroth with his inheritance.

64 The fire consumed their young men : and their maidens were not given to marriage.

1 Sam. iv. 11. 19, 20.

65 Their priests were slain with the sword : and there were no widows to make lamentation.

66 So the Lord awaked as one out of sleep : and like a giant refreshed with wine.

1 Sam. v. 6—12.

67 He smote his enemies in the hinder parts : and put them to a perpetual shame.

1 Sam. vi. 12.

vii. 1.

Isa. xi. 13.

68 He refused the tabernacle of Joseph : and chose not the tribe of Ephraim ;

1 Chron. xvi. 1.

vi. 31.

2 Chron. i. 4.

69 But chose the tribe of Judah : even the hill of Sion which he loved.

2 Chron. ii. 1.

70 And there he built his temple on high : and laid the foundation of it like the ground which he hath made continually.

1 Sam. xvi. 11.

71 He chose David also his servant : and took him away from the sheep-folds.

2 Sam. v. 2.

72 As he was following the ewes great with young ones he took him : that he might feed Jacob his people, and Israel his inheritance.

John x. 11.

Isa. xl. 11

73 So he fed them with a faithful and true heart : and ruled them prudently with all his power.

THE LXXIX PSALM.

Deus, venerunt.

The XVI. Day.

*Morning**Prayer.*

Matt. xxiv. 15.

2 Thess. ii. 4.

Rev. xiii. 6.

O GOD, the heathen are come into thine inheritance : thy holy temple have they defiled, and made Jerusalem an heap of stones.

Et tradidit in captivitatem virtutem eorum : et pulchritudinem eorum in manus inimici.

Et conclusit in gladio populum suum : et hæreditatem suam sprevit.

Juvenes eorum comedit ignis : et virgines eorum non sunt lamentatæ.

Sacerdotes eorum in gladio ceciderunt : et viduæ eorum non plorabantur. non ploraverunt

Et excitatus est tanquam dormiens Dominus : tanquam potens crapulatus a vino.

Et percussit inimicos suos in posteriora : opprobrium sempiternum dedit illis.

Et repulit tabernaculum Joseph : et tribum Ephraim non elegit :

Sed elegit tribum Juda : montem Sion quem dilexit.

Et ædificavit sicut unicornium sanctificium suum : in terra quam fundavit in terra fundavit eum

Et elegit David servum suum, et sustulit eum de gregibus ovium : de post fetantes accepit eum,

Pascere Jacob servum suum : et populum suum Israël hæreditatem suam :

Et pavit eos in innocentia cordis sui : sine malitia cordis in se, suum manuum et in intellectibus manuum suarum deduxit eos.

PSALMUS LXXVIII.

DEUS, venerunt gentes in hæreditatem tuam : polluerunt templum sanctum tuum ; posuerunt Hierusalem in pomorum custodiam.

Thursd. Mattins.
All Saints,
2nd Noct.
conquinaverunt temp.

twenty-first verses. The half belief here indicated is one which has been illustrated in all ages of the Church. It was that which laid the foundation of heresies in the early Church, and that which has hindered the full reception of sacramental doctrine in later times. Up to a certain point doctrines respecting Christ and the Sacraments are received with comparative facility : but there is a point when these become "a hard saying" and many turn back from following after our Lord into the fulness of mystery :— "He smote the stony rock indeed, that the water gushed out, and the streams flowed withal : " He came as a Man beyond all men, He gave mankind the Sacrament of a New Birth in Holy Baptism, " But can He give bread also, or provide flesh for His people ? " did He come simply and truly as God Incarnate ? does

He give the Living Bread from Heaven, His own Flesh, the Life of the Baptized,—in the Sacrament of the Holy Communion ?

It may be observed in conclusion (1) that a comparison of the plagues of Egypt which are here enumerated with certain passages in the Book of the Revelation will show that the Egypt of the Israelites represents typically the Antichrist of the Church : and (2) that as the Lord refused the tabernacle of Joseph and chose not the tribe of Ephraim, so He suffered some of the most flourishing Churches to have their candlestick removed out of its place in the early days of Christianity. The latter warning is for every age of the Church : " Let us therefore fear, lest, a promise being left us of entering into His rest, any of you should seem to come short of it." [Heb. iv. 1.]

<p>The XVI. Day. Morning- Prayer. Rev. xiii. 7. 15. Jerem. vii. 33. xiv. 16—18. Rev. xi. 9, 10.</p>	<p>2 The dead bodies of thy servants have they given to be meat unto the fowls of the air : and the flesh of thy saints unto the beasts of the land.</p> <p>3 Their blood have they shed like water on every side of Jerusalem : and there was no man to bury them.</p> <p>4 We are become an open shame to our enemies : a very scorn and derision unto them that are round about us.</p> <p>5 Lord, how long wilt thou be angry : shall thy jealousy burn like fire for ever?</p>	<p>Posuerunt morticina servorum tuorum escas volatilibus cœli : carnes sanctorum tuorum bestiis terræ.</p> <p>Effuderunt sanguinem eorum tanquam aquam in circuitu Hierusalem : et non erat qui sepeliret.</p> <p>Facti sumus opprobrium vicinis nostris : subsannatio et illusio his qui in circuitu nostro sunt.</p>	<p><i>mortalia</i></p>
<p>Jerem. x. 25.</p>	<p>6 Pour out thine indignation upon the heathen that have not known thee : and upon the kingdoms that have not called upon thy Name.</p>	<p>Usquequo, Domine, irasceris in finem : accendetur velut ignis zelus tuus?</p> <p>Effunde iram tuam in gentes quæ te non noverunt : et in regna quæ Nomen tuum non invocaverunt :</p>	
<p>Rev. xi. 2.</p>	<p>7 For they have devoured Jacob : and laid waste his dwelling-place.</p>	<p>Quia comederunt Jacob : et locum ejus desolaverunt.</p>	
<p>Hosca xiv. 1.</p>	<p>8 O remember not our old sins, but have mercy upon us, and that soon : for we are come to great misery.</p>	<p>Ne memineris iniquitatum nostrarum antiquarum : cito anticipent nos misericordiæ tuæ, quia pauperes facti sumus nimis.</p>	
<p>Rev. vi. 10.</p>	<p>9 Help us, O God of our salvation, for the glory of thy Name : O deliver us, and be merciful unto our sins, for thy Name's sake.</p>	<p>Adjuva nos, Deus salutaris noster, et propter gloriam Nominis tui, Domine, libera nos : et propitius esto peccatis nostris, propter Nomen tuum :</p>	<p><i>honorem</i></p>
<p>Rev. vi. 10.</p>	<p>10 Wherefore do the heathen say : Where is now their God ?</p>	<p>Ne forte dicant in gentibus, Ubi est Deus eorum ? et innotescat in nationibus coram oculis nostris,</p>	
<p>Rev. vi. 10.</p>	<p>11 O let the vengeance of thy servants' blood that is shed : be openly shewed upon the heathen in our sight.</p>	<p>Ultio sanguinis servorum tuorum, qui effusus est : introëat in conspectu tuo gemitus compeditorum.</p>	<p><i>Vindica sanguinem . . . intret</i></p>
<p>Zech. ix. 12.</p>	<p>12 O let the sorrowful sighing of the prisoners come before thee : according to the greatness of thy power, preserve thou those that are appointed to die.</p>	<p>Secundum magnitudinem brachii tui : posside filios mortificatorum.</p>	<p><i>morte punitorum</i></p>

PSALM LXXIX.

The ancient appropriation of this as a proper Psalm for All Saints' Day points out its constant function as a commemoration of the martyrs of the Church. It is also to be taken as a prophecy of those future martyrdoms which our Lord and His Apostle St. John have predicted as characterizing the last great war of Antichrist against the Kingdom of the Cross : for again is heard the cry of the souls under the altar, "How long, O Lord, holy and true, dost Thou not judge and avenge our blood on them that dwell on the earth ?" a fit Antiphon to this Psalm.

The words of the Psalm had, doubtless, a very literal application to the condition of the Jewish nation at such periods of its history as the Babylonish Captivity, and the desolation that fell upon its religion in the time of Antiochus Epiphanes. Jeremiah had predicted, "The carcasses of this people shall be meat for the fowls of the heaven and for the beasts of the earth ; and none shall fray them away . . . Both the great and the small shall

die in this land : and they shall not be buried, neither shall men lament for them : " and no doubt his prophecy was exactly fulfilled. We know also, from the books of the Maccabees, how much the persecution which fell upon Judæa in their days was like the persecution of Christianity three and four centuries later. But, however literally the words of the Psalm may express the sad condition of Judæa at such periods, their meaning is not exhausted by such an application, and there are clearly features of martyrdom portrayed to which the suffering Jews, as a body, could not lay claim.

We are rather to look for the true Christian meaning of this Psalm in the Church of the first three centuries, and of that period of which our Lord prophesied when He spoke of the abomination of desolation standing in the holy place [Matt. xxiv. 15.] : and respecting the troubles of which time He adds, "And except those days should be shortened, there should no flesh be saved, but for the elect's sake those days shall be shortened." Of this desolation of the Church by Antichrist St. Paul also speaks,

The XVI. Day. 13 And for the blasphemy where-
Morning with our neighbours have blasphemed
Prayer. thee : reward thou them, O Lord,
 Jerem. xxxii. 18. seven-fold into their bosom.

14 So we that are thy people and
 John x. 16. sheep of thy pasture shall give thee
 Matt. xv. 24. thanks for ever : and will alway be
 xxv. 33. shewing forth thy praise from gene-
 ration to generation.

THE LXXX PSALM.

Qui regis Israel.

Ezek. xxxiv. 23. **H**EAR, O thou Shepherd of Is-
 xxxvii. 24. rael, thou that leadest Joseph
 John x. 11. 14. like a sheep : shew thy self also, thou
 Heb. xiii. 20. that sittest upon the Cherubims.

Numb. ii. 18-24. 2 Before Ephraim, Benjamin, and
 x. 22-24. Manasses : stir up thy strength, and
 come, and help us.

3 Turn us again, O God : shew the
 light of thy countenance, and we shall
 be whole.

4 O Lord God of hosts : how long
 wilt thou be angry with thy people
 that prayeth ?

5 Thou feedest them with the
 bread of tears : and givest them
 plenteousness of tears to drink.

6 Thou hast made us a very strife
 unto our neighbours : and our enemies
 laugh us to scorn.

7 Turn us again, thou God of
 hosts : shew the light of thy counte-
 nance, and we shall be whole.

John xv. 1. 8 Thou hast brought a vine out of
 Hosea xi. 1. Egypt : thou hast cast out the hea-
 Matt. ii. 15. then, and planted it.

9 Thou madest room for it : and
 when it had taken root it filled the
 land.

Et redde vicinis nostris septuplum
 in sinu eorum : improprium ipsorum,
 quod exprobraverunt tibi, Domine.

Nos autem populus tuus et oves *gregis tui*
 pascuæ tuæ : confitebimur tibi in sæcu-
 lum.

In generatione et generationem : *et in sæculum sæ-
 culi narrabimus* laudem tuam.

PSALMUS LXXIX.

QUI regis Israël, intende : qui de- Thursd. Mattins.
 ducis velut ovem Joseph.

Qui sedes super Cherubin : mani- *appare coram*
 festare coram Ephraim, Benjamin, et
 Manasse.

Excita potentiam tuam, et veni : ut
 salvos facias nos.

Deus converte nos : et ostende fa- *Domine Deus*
 ciem tuam, et salvi erimus. *virtutum*

Domine Deus virtutum : quousque
 irasceris super orationem servi tui ?

Cibabis nos pane lachrymarum : et
 potum dabis nobis in lachrymis in
 mensura ?

Posuisti nos in contradictionem
 vicinis nostris : et inimici nostri sub- *deriserunt*
 sannaverunt nos.

Deus virtutum, converte nos : et *Domine Deus*
 ostende faciem tuam, et salvi erimus.

Vineam de Ægypto transtulisti :
 ejecisti gentes, et plantasti eam.

Dux itineris fuisti in conspectu *Viam fecisti in*
 ejus : et plantasti radices ejus, et im- *consp.*
 plevit terram. *repleta est terra*

clearly intimating at the same time that its peculiar and dread-
 ful character cannot be fully comprehended until it is "revealed"
 by its actual occurrence. "That Day shall not come," says
 he, "except there come a falling away first, and that man of
 sin be revealed, the son of perdition : who opposeth and exalteth
 himself above all that is called God, or that is worshipped, so that
 he, as God, sitteth in the temple of God, showing himself that he
 is God." [2 Thess. ii. 3, 4.] To the reign of this Enemy of God
 the book of the Revelation applies almost exactly the opening
 verses of this Psalm :—"And when they shall have finished their
 testimony, the beast that ascendeth out of the bottomless pit
 shall make war against them, and shall overcome them, and kill
 them. And their dead bodies shall lie in the street of the great
 city, which spiritually is called Sodom, and Egypt, where also
 our Lord was crucified." As the Revelation was written long
 after the destruction of Jerusalem, it is clearly to some future

period that these words refer. And to such period, also, does
 this Psalm refer whose mystical meaning may often receive a
 partial fulfilment, but a complete one only in the last great and
 terrible days.

PSALM LXXX.

This is a hymn of prayer to the Good Shepherd of the new
 Israel : to Him Who knows His sheep by name, and Who
 leadeth them in the wilderness of this world like a flock even
 while He sits enthroned in the world on high surrounded by His
 unfallen flock, the hosts of Heaven. The first verse catches up
 the strain of the preceding Psalm, "We that are Thy people, and
 the sheep of thy pasture : " but the more characteristic figure of
 the Psalm is that of the Vine, which our Lord subsequently
 adopted in the interpretative form : "I am the Vine, ye are the
 branches." Hence also the mournful reference to God's ancient

The XVI. Day
Morning
Prayer.
Isa. v. 1-7

10 The hills were covered with the shadow of it : and the boughs thereof were like the goodly cedar-trees.

11 She stretched out her branches unto the sea : and her boughs unto the river.

Isa. v. 5.

12 Why hast thou then broken down her hedge : that all they that go by pluck off her grapes ?

13 The wild boar out of the wood doth root it up : and the wild beasts of the field devour it.

14 Turn thee again, thou God of hosts, look down from heaven : behold, and visit this vine ;

Jerem. xxiii. 5.
Zech. iii. 8.
vi. 12.

15 And the place of the vineyard that thy right hand hath planted : and the branch that thou madest so strong for thy self.

16 It is burnt with fire, and cut down : and they shall perish at the rebuke of thy countenance.

Ps xciii. 1.
Matt. iii. 16, 17.

17 Let thy hand be upon the man of thy right hand : and upon the son of man, whom thou madest so strong for thine own self.

18 And so will not we go back from thee : O let us live, and we shall call upon thy Name.

19 Turn us again, O Lord God of hosts : shew the light of thy countenance, and we shall be whole.

Operuit montes umbra ejus : et arbusta ejus cedros Dei.

Extendit palmites suos usque ad mare : et usque ad flumen propagines ejus.

Ut quid destruxisti maceriam ejus : *deposuisti* et vindemiant eam omnes, qui prætergrediuntur viam ? *transcunt*

Exterminavit eam aper de silva : et singularis ferus depastus est eam.

Deus virtutum, convertere : respice *Domine* Deus de celo, et vide, et visita vineam istam.

Et perface eam quam plantavit *dirige* dextera tua : et super filium hominis quem confirmasti tibi.

Incensa igni et suffossa : ab *effussa manu* incensatione vultus tui peribunt :

Fiat manus tua super virum dexteræ tuæ : et super filium hominis quem confirmasti tibi.

Et non discedimus a te ; vivificabis nos : et Nomen tuum invocabimus.

Domine Deus virtutum, converte nos : et ostende faciem tuam, et salvi erimus.

favour towards His people becomes a prayer against that falling away altogether from the True Vine of which our Lord said, "If a man abide not in Me, he is cast forth as a branch, and is withered ; and men gather them, and cast them into the fire, and they are burned." [John xv. 6.]

This parable of the Vine illustrates the wonderful consistency of Holy Scripture in general, and of prophecy in particular. The vineyard was an ancient figure in prophecy as regarded the Israelites and their kingdom: and though, humanly speaking, it might have become so because of the local importance of the Vine and the familiarity of it in all its aspects to the people ; yet there is evidently a Divine spiritual meaning underlying all that is said about it. Noah planted a vineyard immediately on leaving the Ark, probably on the south-east slopes of Lebanon : Melchizedek, king of Salem nearly five hundred years before the descendants of Abraham were "brought out of Egypt," brought to the Patriarch a symbolical offering of the fruit of the Corn of wheat, and the juice of the True Vine : Jacob, in his blessing, declared of Judah, "The sceptre shall not depart from Judah, nor a lawgiver from between his feet, until Shiloh come : and until him shall the gathering of the people be. Binding his foal unto the Vine, and his ass's colt unto the choice Vine, he washed his garments in wine, and his clothes in the blood of grapes ; his eyes shall be red with wine, and his teeth white with milk." [Gen. xlix. 10, 12. Cf. Isa. lxiii. 1-3.]

Passing over other illustrations furnished by the early history of Israel [e.g. Deut. viii. 8. Numb. xx. 5 ; xiii. 1. Deut. vi. 11. Cant. viii. 11. Isa. vii. 1. 23.], we come to the Vine and

Vineyard of this Psalm, of Isaiah v. 1-7, and of our Blessed Lord's Parables ; all which bear a consistent interpretation as applicable to the ancient Church of God among the children of Israel, and to the Mystical Body of the True Vine.

The wail of this Psalm carries back the mind to the prophecy of Moses, and to that of our Lord. The one had declared, among the threatenings with which He almost closed His work, "Thou shalt plant a vineyard, and shalt not gather the grapes thereof : . . . the fruit of thy land and all thy labours shall a nation which thou knowest not eat up" [Deut. xxviii. 30, 33.] : and among the last words of our Lord were those, the meaning of which was so well understood by the Jews, "He shall come and destroy these husbandmen, and give the vineyard to others." [Luke xx. 16.]

Thus the stream of prophecy is always found to be flowing in the same direction, leading us to the conclusion that as God's Providence brought out of Egypt the Vine of the Jewish Church and planted it in the Mount of God, to take deep root and fill the land from the Mediterranean to the Jordan and to be His own Vineyard, so did He "break down her hedge" and "give the vineyard to others," because of the fruitlessness of the Vine through the wickedness of the husbandmen. The same prophecy teaches us that the Vineyard of the Lord is now planted in "a very fruitful field" and has taken deep root throughout the world, but that times of apostasy will yet come when the faithful part of Christ's Church will have to take up the words of this Psalm as the faithful Jews wailed out their sorrow before God during the Babylonish Captivity. In prospect of that time, and at all

THE LXXXI PSALM.

Exsultate Deo.

The XVI. Day.
*Morning
Prayer.*
Isa. lii. 9.
Rev. xix. 6.

SING we merrily unto God our strength : make a cheerful noise unto the God of Jacob.

2 Take the psalm, bring hither the tabret : the merry harp with the lute.

Levit. xxiv. 9.
Numb. x. 10.
1 Cor. xv. 52.
Rev. i. 10.
iv. 1.

3 Blow up the trumpet in the new-moon : even in the time appointed, and upon our solemn feast-day.

4 For this was made a statute for Israel : and a law of the God of Jacob.

5 This he ordained in Joseph for a testimony : when he came out of the land of Egypt, and had heard a strange language.

Exod. v. 4, 7, 8.

6 I eased his shoulder from the burden : and his hands were delivered from making the pots.

7 Thou calledst upon me in troubles, and I delivered thee : and heard thee what time as the storm fell upon thee.

8 I proved thee also : at the waters of strife.

Isa. xlviii. 12.

9 Hear, O my people, and I will assure thee, O Israel : if thou wilt hearken unto me,

10 There shall no strange god be in thee : neither shalt thou worship any other god.

Ezek. iii. 1.
Rev. x. 8-11.

11 I am the Lord thy God, who brought thee out of the land of Egypt : open thy mouth wide, and I shall fill it.

12 But my people would not hear my voice : and Israel would not obey me.

PSALMUS LXXX.

EXSULTATE Deo adjutori nostro: Friday Mattins.
All Saints,
3rd Noct.
jubilare Deo Jacob.

Sumite psalmum, et date tympanum: psalterium jucundum cum cithara.

Buccinate in neomenia tuba: in in- Cantate in initio
mensis
signi die solennitatis vestrae :

Quia praeceptum in Israël est: et judicium Deo Jacob.

Testimonium in Joseph posuit illud, cum exiret de terra Ægypti: linguam quam non noverat audivit.

Divertit ab oneribus dorsum ejus: manus ejus in cophino servierunt.

In tribulatione invocasti me, et liberavi te: exaudivi te in abscondito tempestatis; probavi te apud aquam contradictionis.

Audi populus meus et contestabor et loquar Israel
et testificabor
tibi
te: Israël si audieris me, non erit in te deus recens, neque adorabis deum alienum.

Ego enim sum Dominus Deus tuus, qui eduxi te de terra Ægypti: dilata os tuum et implebo illud.

Et non audivit populus meus vocem meam: et Israël non intendit mihi.

periods when afflictions befall the Church of Christ, the remembrance of our Lords words, "I am the Vine, ye are the branches," may give comfort such as the Jews could not possess, teaching that the Church is so associated with the Lord Himself that nothing can finally overthrow it. And while she cries "Turn us again, O Lord God of hosts," she can also say "Let Thy hand be upon the Man of Thy right hand: and upon the Son of Man Whom Thou madest so strong for Thine own self." The sacramental Life of the Vine can never be destroyed, because it is the Life of Christ our God.

PSALM LXXXI.

As the previous mournful hymn of the Church represents Christ's Mystical Body under the figure of a Vine, it seems to be with some mystical reason that this Psalm of the Church's triumph is entitled "Upon Gittith," i. e., as the Septuagint translates it, "upon the winepress." For so, when the question is asked, "Who is this that cometh from Edom, with dyed gar-

ments from Bozrah? this that is glorious in His apparel, travelling in the greatness of His strength? . . . Wherefore art Thou red in Thine apparel, and Thy garments like him that treadeth in the wine-vat?" the triumphant Messiah answers, "I have trodden the winepress alone." So also the same Lord, speaking by Isaiah, speaks of the winepress which He has made in His vineyard [Isa. v. 2]; in the parable which He spoke to the Jews He also uses the same figure [Matt. xxi. 33]: and in the last triumph of Christ and His Church there is "a winepress without the City, and blood came out of the winepress." [Rev. xiv. 20.] Thus it seems that the title of this Psalm as well as its substance indicates it to be a hymn of victory for the Church when the days of her warfare are accomplished, and her sorrow is at an end.

Thus at the new "beginning of months," the "solemn feast-day" when the "trumpet shall sound and the dead shall be raised," the song of joy is heard "Sing we merrily unto God our strength," "Alleluia, for the Lord God omnipotent reigneth." It is the song of the Church's deliverance from Egypt, and of her deliv-

The XVI. Day. Morning Prayer. 13 So I gave them up unto their own hearts' lusts : and let them follow their own imaginations.

Isa. xlviii. 18. 14 O that my people would have hearkened unto me : for if Israel had walkéd in my ways,

15 I should soon have put down their enemies : and turned my hand against their adversaries.

16 The haters of the Lord should have been found liars : but their time should have endured for ever.

Deut. xxxii. 13. 14. John vi. 31. Cant. iv. 11. 1 Cor. x. 14. 17 He should have fed them also with the finest wheat-flour : and with honey out of the stony rock should I have satisfied thee.

THE LXXXII PSALM.

Deus stetit.

Evening Prayer. Luke xxii. 66. GOD standeth in the congregation of princes : he is a Judge among gods.

Luke xxii. 71. xxiii. 10. 18. 2 How long will ye give wrong judgement : and accept the persons of the ungodly ?

3 Defend the poor and fatherless : see that such as are in need and necessity have right.

4 Deliver the out-cast and poor : save them from the hand of the ungodly.

John xii. 36, 37. 5 They will not be learned nor understand, but walk on still in darkness : all the foundations of the earth are out of course.

Exod. xxviii. 28. Acts xxiii. 5. John x. 34. 6 I have said, Ye are gods : and ye are all the children of the most Highest.

7 But ye shall die like men : and fall like one of the princes.

Isa. lx. 3. John x. 16. 8 Arise, O God, and judge thou the earth : for thou shalt take all heathen to thine inheritance.

Et dimisi eos secundum desideria cordis eorum : ibunt in adinventio-^{in voluntatibus suis} nibus suis.

Si populus meus audisset me : Israëli si in viis meis ambulasset :

Pro nihilo forsitan inimicos eorum^{Ad nihilum inimicos} humiliassem : et super tribulantes eos misissem manum meam.

Inimici Domini mentiti sunt ei : et erit tempus eorum in sæcula.^{in æternum}

Et cibavit eos ex adipe frumenti : et de petra melle saturavit eos.^{saturavit eos}

PSALMUS LXXXI.

DEUS stetit in synagoga deorum :^{Friday Mattins.} in medio autem deos dijudicat.^{Deus discernit}

Usquequo judicatis iniquitatem : et facies peccatorum sumitis ?

Judicate egeno et pupillo : humilem et pauperem justificare.

Eripite pauperem : et egenum de manu peccatoris liberate.

Nescierunt, neque intellexerunt ; in tenebris ambulānt : movebuntur omnia fundamenta terræ.

Ego dixi, Dii estis : et filii Excelsi omnes.

Vos autem sicut homines moriemini : et sicut unus de principibus cadetis.

Surge, Deus, judica terram : quoniam^{Exsurge} tu hæreditabis in omnibus gentibus.

rance from "the burden" of sin, and the death which comes from sin¹.

In that day it will be plainly seen by all that the triumph of the people of God is the result of His mercy in Christ, and not of their own worthiness : that though the prayer has been going up continually "Thy Kingdom Come," yet the coming of that Kingdom has been hindered by the sins of Israel : that the words of this Psalm are literally true, "If Israel had walked in My ways, I should soon have put down their enemies:" and that

¹ It is not altogether without interest that the word translated "pots" (literally "baskets"), is rendered by a word identical with our English "coffins," both in the LXX and the Vulgate. The practice of Urn-burial is well known.

even in her highest triumph "no man in Heaven, nor in earth, neither under the earth, will be able to open the Book," or be found worthy to stand in his own righteousness. The final interpretation of "Sing we merrily unto God our strength," will therefore be, "Worthy is the Lamb that was slain to receive power, and riches, and wisdom, and strength, and honour, and glory, and blessing." [Rev. v. 12.]

PSALM. LXXXII.

When the Incarnate WORD stood before the Sanhedrim, the first verses of this Psalm were literally fulfilled : GOD—the Second Person of the Blessed Trinity inseparably united with Human Nature—standing in the congregation of princes, and the

THE LXXXIII PSALM.

*Deus, quis similis?*The XVI. Day.
Evening
*Prayer.***H**OLD not thy tongue, O God,
keep not still silence : refrain
not thy self, O God.2 For lo, thine enemies make a mur-
muring : and they that hate thee have
lift up their head.Rev. xiii. 13.
Col. iii. 3.3 They have imagined craftily
against thy people : and taken coun-
sel against thy secret ones.

Rev. xiii. 15.

4 They have said, Come, and let us
root them out, that they be no more a
people : and that the name of Israel
may be no more in remembrance.

Rev. xvii. 13.

5 For they have cast their heads
together with one consent : and are
confederate against thee ;Dan. vii. 24.
Rev. xiii. 1.
xvii. 12.6 The tabernacles of the Edomites,
and the Ismaelites : the Moabites, and
Hagarens ;7 Gebal, and Ammon, and Amalek :
the Philistines, with them that dwell
at Tyre.8 Assur also is joined with them :
and have holpen the children of Lot.9 But do thou to them as unto the
Madianites : unto Sisera, and unto
Jabin at the brook of Kison ;10 Who perished at Endor : and
became as the dung of the earth.Judg. vii. 28.
viii. 12. 21.11 Make them and their princes
like Oreb and Zeb : yea, make all
their princes like as Zeba and Salmana ;12 Who say, Let us take to our
selves : the houses of God in posses-
sion.Isa. xviii. 13.
Job xxi. 18.13 O my God, make them like unto
a wheel : and as the stubble before the
wind ;

PSALMUS LXXXII.

DEUS, quis similis erit tibi? ne
taceas, neque comescaris, Deus : Friday Mattins.Quoniam ecce inimici tui sonuerunt:
et qui oderunt te extulerunt caput.Super populum tuum malignaverunt *In plebem tuam*
astute cogitave-
runt consilium
consilium : et cogitaverunt adversus
sanctos tuos.Dixerunt, Venite et disperdamus eos
de gente : et non memoretur nomen
Israël ultra. *amplius*Quoniam cogitaverunt unanimiter *consensum in*
unum simul
simul adversus te : testamentum dis-
posuerunt, tabernacula Idumæorum et
Ismaelitæ :Moab, et Agareni, Gebal, et Ammon,
et Amalec : alienigenæ, cum habitanti-
bus Tyrum.Etenim Assur venit cum illis : facti
sunt in adjutorium filiis Lot. *susceptione filijs*Fac illis sicut Madian et Sisaræ :
sicut Jabin in torrente Cison.Disperierunt in Endor : facti sunt
ut stercus terræ.Pone principes eorum sicut Oreb et
Zeb : et Zebee, et Salmana.Omnes principes eorum qui dix-
erunt : Hæreditate possideamus sanc-
tuarium Dei.Deus meus, pone illos ut rotam : et
sicut stipulam ante faciem venti.

Judge of all the world among the judges. So also was the second verse literally fulfilled when wrong judgment was given against the Holy One, and the person of the ungodly murderer and rebel Barabbas accepted instead. "All the foundations of the earth" seemed indeed to be "out of course" when such terrible injustice could be done by judges who, on account of their most sacred office, had received from God Himself the name of "gods." The last words of our Lord's public ministrations were, "While ye have the light, believe in the light, that ye may be the children of light." But they walked on still in darkness, unwilling to learn from Him or to understand His words. Therefore the Jews were given up by God :—"Ye shall die like men," while He Who stood before the unjust judges arose in the glory of His new Kingdom to "take all the heathen to" that inheritance which His ancient people had despised.

Such seems to be the prophetic and Christian meaning of this

Psalm. Its meaning as a general exhortation to all judges is too obvious to need illustration.

PSALM LXXXIII.

A continuation of the call for judgment upon the enemies of Christ and His Church is to be found in this Psalm. At the time of the great Diocletian persecution a general attempt was made throughout the world to destroy the Church, and the words of the fourth verse are strongly illustrated by the heathen monuments of the day, which declared that Christianity had been overthrown, and its very name blotted out. The agreement of the Cæsars who governed the Roman world in such an universal persecution may be represented by the confederation of the ten nations named in the sixth, seventh, and eighth verses. Notwithstanding the fierceness of this terrible persecution, the Church was so far from being rooted out as that it should be no more a people, and the

The XVI. Day. Evening Prayer. 14 Like as the fire that burneth up the wood : and as the flame that consumeth the mountains.

15 Persecute them even so with thy tempest : and make them afraid with thy storm.

16 Make their faces ashamed, O Lord : that they may seek thy Name.

17 Let them be confounded and vexed ever more and more : let them be put to shame and perish.

Zech. xiv. 9. Rev. xvii. 14.

18 And they shall know that thou, whose Name is Jehovah : art only the most Highest over all the earth.

THE LXXXIV PSALM.

Quam dilecta.

O HOW amiable are thy dwellings : thou Lord of hosts.

Luke xxiii. 6. Phil. i. 23. iii. 8-11.

2 My soul hath a desire and longing to enter into the courts of the Lord : my heart and my flesh rejoice in the living God.

Matt. viii. 20.

3 Yea, the sparrow hath found her an house, and the swallow a nest where she may lay her young : even thy altars, O Lord of hosts, my King and my God.

4 Blessed are they that dwell in thy house : they will be alway praising thee.

Ps. i. 1.

5 Blessed is the man whose strength is in thee : in whose heart are thy ways.

John iii. 10. 14. Isa. xii. 3.

6 Who going through the vale of misery use it for a well : and the pools are filled with water.

Sicut ignis qui comburit silvam : et sicut flamma comburens montes : *incendat montes*

Ita persecueris illos in tempestate tua : et in ira tua turbabis eos.

Imple facies eorum ignominia : et quaerent Nomen tuum, Domine.

Erubescant, et conturbentur in *Confundantur et saeculum saeculi : et confundantur, et recedant et pereant.*

Et cognoscant quia nomen tibi Dominus : tu solus Altissimus in omni terra.

PSALMUS LXXXIII.

QUAM dilecta tabernacula tua, Domine virtutum : concupiscit et deficit anima mea in atria Domini.

Friday Mattins. All Saints, Dedic. Ch., 2nd Noct. *Quam amabilia sunt concupivit et defecit*

Cor meum et caro mea : exultaverunt in Deum vivum.

Etenim passer invenit sibi domum et turtur nidum sibi : ubi reponat pullos suos :

Altaria tua, Domine virtutum : Rex meus, et Deus meus.

Beati qui habitant in domo tua, Domine : in saecula saeculorum laudabunt te.

Beatus vir cujus est auxilium abs te : *abs te Domine ascensionem* in corde suo disposuit, in valle lachrymarum, in loco quem posuit. *quem disposuit eis*

name of Christ's Israel no more had in remembrance, that it arose from its ashes to a life of greater vigour than before, and within a few years was the one recognized religion of the very Empire which had attempted its extermination.

Such a general persecution of the Church has never again occurred, but there is a continuous confederacy of its various foes, who are the representatives of the ten nations named in this Psalm. Some utterly reject the Lord Jesus Christ, as the Heathen and the utter Infidel. Some recognize Him, in a certain sense, as the Mahometans, and the various sects of (falsely so called) "Unitarian" heretics. Some recognize the Person of the Lord, but deny His work in His Mystical Body. Some, by their wickedness, practically reject both Him and His work, though they may theoretically acknowledge Him. All these various classes are among the enemies of God who "make a murmuring," and in their hatred "lift up their head" whenever favourable opportunities occur of opposing Christ and His Church.

But the mystical meaning of the Psalm has probably a prophetic aspect which bears reference to the enmity and opposition of Antichrist in the last time. In him all the various opponents of the Church will find a "head" whom they may "lift up"

against Christ, as one professing himself to be God in the place of the Lord Jesus, and accepting Divine worship in the Church. Thus, perhaps, the ten nations of the Psalm find their parallel in the ten kingdoms of Antichrist; and the final "Come, let us root them out," is represented by the prophetic record, that he caused "that as many as would not worship the image of the beast should be killed." [Rev. xiii. 15.]

PSALM LXXXIV.

This is the prayer of the Anointed of the Lord, our Saviour Jesus Christ, expressing the longing of His Soul while on earth ; a longing which was revealed in its suffering form when He said, "Foxes have holes, and birds of the air have nests, but the Son of Man hath not where to lay His head." All the creatures of God found a resting-place in the loving care and Providence of their Maker, but the Son of Man looked on afar at the Presence of His Father as One who had taken upon Himself the form of sinful man, of man cast out of the Paradise of God. "The Man," therefore, whose blessedness is proclaimed in the fifth verse is the same MAN Who is set before us in the very first words of the book of Psalms ; and the blessedness here spoken of

The XVI. Day.
Evening
Prayer.
2 Cor. iii. 18.
Matt. v. 8.
Rev. xxii. 4.

7 They will go from strength to strength : and unto the God of gods appeareth every one of them in Sion.

8 O Lord God of hosts, hear my prayer : hearken, O God of Jacob.

9 Behold, O God our defender * and look upon the face of thine Anointed.

Luke xxiii. 43. 10 For one day in thy courts : is better than a thousand.

Cf. Acts xix. 35,
in the Greek.

11 I had rather be a door-keeper in the house of my God : than to dwell in the tents of ungodliness.

Isa. lx. 1. 19.
Rev. xxi. 23.

12 For the Lord God is a light and defence : the Lord will give grace and worship, and no good thing shall he withhold from them that live a godly life.

13 O Lord God of hosts : blessed is the man that putteth his trust in thee.

THE LXXXV PSALM.

Benedixisti, Domine.

Christmas Day
Mattins.

LORD, thou art become gracious unto thy land : thou hast turned away the captivity of Jacob.

Isa. liv. 7.
Heb. ix. 12.

2 Thou hast forgiven the offence of thy people : and covered all their sins.

3 Thou hast taken away all thy displeasure : and turned thy self from thy wrathful indignation.

Etenim benedictionem dabit legislator ; ibunt de virtute in virtutem : videbitur Deus deorum in Sion. dabit qui legem dedit ambulantes

Domine, Deus virtutum, exaudi orationem meam : auribus percipe Deus Jacob. precem meam

Protector noster aspice, Deus : et respice in faciem Christi tui :

Quia melior est dies una in atriis tuis : super millia.

Elegi abjectus esse in domo Dei mei : magis quam habitare in tabernaculis peccatorum.

Quia misericordiam et veritatem diligit Deus : gratiam et gloriam dabit Dominus.

Non privabit bonis eos qui ambulat in innocentia : Domine virtutum, beatus homo qui sperat in te. Dominus non ... ambulantes

PSALMUS LXXXIV.

BENEDIXISTI, Domine, terram tuam : avertisti captivitatem Jacob. Friday Mattins Christmas, 2nd Noct.

Remisisti iniquitatem plebis tuæ : operuisti omnia peccata eorum.

Mitigasti omnem iram tuam : avertisti ab ira indignationis tuæ.

is that arising from His entire submission of His heart to the ways of the Divine Providence and purpose respecting the redemption of mankind. By such submission His "strength" was elevated above the strength of even the holiest humanity, and became a superhuman, Divine strength, a strength in God, "mighty to save." Thus endowed with the power of the Incarnation, our Lord passed through the "vale of misery," making His humiliation a fountain or well of life, as if the tears which He shed had become inexhaustible "pools" of living water springing up into everlasting life. Such is the strength of our Lord's Incarnation on earth ; but "they" will go from strength to strength, and unto the God of gods appeareth every one of them in Sion." Jesus Triumphant is even more "mighty to save" than Jesus Suffering ; the Intercessor offering His Sacrifice before the Throne is even more the "Strength of Israel" than the Saviour offering that Sacrifice upon the Cross. Let us look, therefore, not only on the Crucifix, setting forth His Passion before our eyes, but let us also hear the words of the angel, "He is not here, but is risen," and behold in the vacant Cross, as in the empty tomb, the Sign of the Son of Man's continual Sacrifice of Intercession ; a passing from the strength of earth to the strength of Heaven. By such an Ascension did the Son of Man find the aspirations of His heart fulfilled that His human heart and flesh should rejoice in the living God, entering into His courts, and dwelling there for an eternal "day."

¹ The frequent interchange of pronouns is here again illustrated. Compare notes at pp. 324, 347.

From such a view of this Psalm it is easy to see also that it reveals Christ praying for His Mystical Body that it may be glorified by its final reception into the Divine Presence. Here the Church of God is in the "vale of tears," but the everlasting benediction of God will go forth upon its work as the Church Militant in a state of grace, so that though "weeping may endure for a night, joy cometh in the morning," when it enters on a state of glory. "But we all, with open face beholding as in a glass the glory of the Lord, are changed into the same image from glory to glory, even as by the Spirit of the Lord."

In viewing the Psalm as the words of our Blessed Lord, we shall also find the key to its use as the words of His members. Nothing else uttered by human lips ever so fully expressed the longing which the devout soul, especially in seasons of sorrow, has to "depart and be with Christ" even in "the lowest room." Oh, how much rather the most abject place in "the house not made with hands," than the highest throne in the mystical Babylon ! How infinite the blessings of one day in Heaven, compared to all that earth can furnish in threescore years and ten !

PSALM LXXXV.

The Incarnation of our Blessed Lord was the true turning away of the Captivity of God's people, and His speaking of peace to them ; so that this Psalm has been appropriated, time immemorial, to the celebration of His Nativity ; when a multitude of the heavenly host was heard "praising God, and saying, Glory to God in the highest, and on earth peace, goodwill towards men." To Him Who is the Prince of Peace, Who said of Him-

The XVI. Day.
Evening
Prayer.
Zech. i. 3.

4 Turn us then, O God our Saviour :
and let thine anger cease from us.

5 Wilt thou be displeased at us for
ever : and wilt thou stretch out thy
wrath from one generation to another?

Rev. vi. 10.
Ezek. xxxviii.
1-14.

6 Wilt thou not turn again, and
quicken us : that thy people may re-
joice in thee ?

7 Shew us thy mercy, O Lord : and
grant us thy salvation.

Isa. lx. 6.
Luke ii. 14.

8 I will hearken what the Lord God
will say concerning me : for he shall
speak peace unto his people, and to his
saints, that they turn not again.

Luke x. 9.
Rev. xxi. 3-11.
John i. 14, 17.

9 For his salvation is nigh them
that fear him : that glory may dwell
in our land.

Rom. i. 5.

10 Mercy and truth are met toge-
ther : righteousness and peace have
kissed each other.

John i. 14.
xiv. 6.
Rev. xix. 11.

11 Truth shall flourish out of the
earth : and righteousness hath looked
down from heaven.

Isa. xxvi. 15.

12 Yea, the Lord shall shew loving-
kindness : and our land shall give her
increase.

Isa. xl. 5.

13 Righteousness shall go before
him : and he shall direct his going in
the way.

THE LXXXVI PSALM.

Inclina, Domine.

The XVII. Day.
Morning
Prayer.
2 Cor. viii. 9.

BOW down thine ear, O Lord, and
hear me : for I am poor and in
misery.

Rev. xv. 3, 4.
1 Cor. i. 2.
Lev. xi. 44, 45.
1 Pet. i. 15.]

2 Preserve thou my soul, for I am
holy : my God, save thy servant that
putteth his trust in thee.

Heb. v. 7.

3 Be merciful unto me, O Lord :
for I will call daily upon thee.

4 Comfort the soul of thy servant :
for unto thee, O Lord, do I lift up my
soul.

Converte nos, Deus salutaris noster :
et averte iram tuam a nobis.

Nunquid in æternum irasceres nobis? *Ut non in æternum*
aut extends iram tuam a generatione *neque ext. . . a*
in generationem. *progenie in pro-*
geniem

Deus, tu conversus vivificabis nos : *conversens*
et plebs tua lætabitur in te.

Ostende nobis, Domine, misericor-
diam tuam : et salutare tuum da nobis.

Audiam quid loquatur in me, Domi-
nus Deus : quoniam loquetur pacem in
plebem suam :

Et super sanctos suos : et in eos qui
convertuntur ad cor. *ad ipsum*

Veruntamen prope timentes eum
salutare ipsius : ut inhabitet gloria in
terra nostra.

Misericordia et veritas obviaverunt
sibi : justitia et pax osculatæ sunt. *completae sunt s3*

Veritas de terra orta est : et justitia
de cœlo prospexit.

Etenim Dominus dabit benignita-
tem : et terra nostra dabit fructum
suum.

Justitia ante eum ambulabit : et
ponet in via gressus suos.

PSALMUS LXXXV.

INCLINA, Domine, aurem tuam, et
exaudi me : quoniam inops et
pauper sum ego. *Friday Mattins.
Epiphany,
2nd Noct.
egenus et*

Custodi animam meam, quoniam
sanctus sum : salvum fac servum
tuum, Deus meus, sperantem in te.

Miserere mei, Domine, quoniam ad
te clamavi tota die ; lætifica animam
servi tui : quoniam ad te, Domine, ani-
mam meam levavi.

self, "I am the Way, the Truth, and the Life," and Whose per-
fect Righteousness fits Him to be the Judge of all men, to Him
and to His work alone such words as those of the ninth and fol-
lowing verses belong : and in His constant declarations, "The
Kingdom of Heaven is at hand," "The Kingdom of God is
come nigh unto you," "The Kingdom of God is within you," the
Psalmist's prophecy is fulfilled, "For His salvation is nigh them
that fear Him."

The penitential tone of verses 4-7, shows that this Psalm
looks also prophetically to the second Coming of our Lord, and
the "quickenings" of the general resurrection. Until then the
Church is going through a second captivity, since it cannot

before enter upon the full glory of its inheritance. When that
captivity draws to a close, the Prince of Peace will again fulfil
the eleventh verse—He that is "called Faithful and True"
going forth "in righteousness" to "judge and make war" that
"glory may dwell in our land" by the subjugation of all evil.

PSALM LXXXVI.

The central idea of this Psalm is to be found in the central
verse, the ninth, which doubtless gives the key to its use as an
Epiphany Psalm in the ancient system of the Church. It is en-
titled "a Prayer of David," and is to be taken as the supplication
of Him Whom David prefigured. In "the time of His trouble,"

The XVII. Day.
Morning
Prayer.

5 For thou, Lord, art good and gracious : and of great mercy unto all them that call upon thee.

6 Give ear, Lord, unto my prayer : and ponder the voice of my humble desires.

John xi. 33. 41.
xii. 27, 28.

7 In the time of my trouble I will call upon thee : for thou hearest me.

Heb. i. 4-14.
1 Cor. viii. 5, 6.

8 Among the gods there is none like unto thee, O Lord : there is not one that can do as thou doest.

Phil. ii. 10.
Rev. v. 9-14.
iv. 11. vii. 9.
xv. 3, 4.

9 All nations whom thou hast made shall come and worship thee, O Lord : and shall glorify thy Name.

10 For thou art great, and doest wondrous things : thou art God alone.

11 Teach me thy way, O Lord, and I will walk in thy truth : O knit my heart unto thee, that I may fear thy Name.

12 I will thank thee, O Lord my God, with all my heart : and will praise thy Name for evermore.

Ps. xvi. 10.
Acts ii. 31.
[Matt. xvi. 18.
Jonah ii. 2.
Col. i. 13.]

13 For great is thy mercy toward me : and thou hast delivered my soul from the nethermost hell.

14 O God, the proud are risen against me : and the congregations of naughty men have sought after my soul, and have not set thee before their eyes.

Exod. xxxiv. 6.

15 But thou, O Lord God, art full of compassion and mercy : long-suffering, plenteous in goodness and truth.

16 O turn thee then unto me, and have mercy upon me : give thy strength unto thy servant, and help the son of thine handmaid.

Luke i. 48.

Isa. liii. 11.
Rev. i. 7.
Matt. xxiv. 30.

17 Shew some token upon me for good, that they who hate me may see it, and be ashamed : because thou, Lord, hast holpen me and comforted me.

Quoniam tu, Domine, suavis, et mitis ; et multæ misericordiæ omnibus et copiosus in misericordiâ invocantibus te.

Auribus percipe, Domine, orationem meam : intende voci deprecationis meæ.

In die tribulationis meæ clamavi ad te : quia exaudisti me.

Non est similis tui in diis, Domine : et non est secundum opera tua.

Omnes gentes quascunque fecisti, venient et adorabunt coram te, Domine : et glorificabunt Nomen tuum. honorificabunt

Quoniam magnus es tu, et faciens mirabilia : tu es Deus solus.

Deduc me, Domine, in via tua, et ingrediari in veritate tua : lætetur cor meum ut timeat Nomen tuum. ambulabo

Confitebor tibi, Domine, Deus meus, in toto corde meo : et glorificabo Nomen tuum in æternum. honorificabo

Quia misericordia tua magna est super me : et eruisti animam meam ex inferno inferiori. eripuisti

Deus, iniqui insurrexerunt super me, et synagoga potentium quæsierunt animam meam : et non proposuerunt te in conspectu suo.

Et tu, Domine Deus, miserator et misericors : patiens, et multæ misericordiæ, et verax. meus miserator multum misericors

Respice in me et miserere mei ; da imperium tuum puero tuo : et salvum fac filium ancillæ tuæ. potestatem puero

Fac mecum signum in bono, ut videant qui oderunt me, et confundantur : quoniam tu, Domine, adjuvisti me, et consolatus es me. mecum Domine

even when "He groaned in the spirit" again and again, He was able to say, "Father, I thank Thee that Thou hast heard Me." So also when He said, "Now is My soul troubled, and what shall I say? Father, save Me from this hour? But for this cause came I unto this hour: Father, glorify Thy Name. Then came there a voice from heaven, saying, I have both glorified it, and will glorify it again." Thus the perfect obedience of the Son of Man when He was "poor and in misery" brought for His Human Nature the highest Epiphanies of Divine glory; and eventually brought all nations to come and worship Him, and glorify His Name. "And they sing the song of Moses, the servant of God, and the song of the Lamb, saying, Great and marvellous are Thy works, Lord God Almighty; just and true are Thy ways, Thou King of saints. Who shall not fear Thee,

O Lord, and glorify Thy Name? For Thou only art holy; for all nations shall come and worship before Thee; for Thy judgments are made manifest." Only He who is "King of saints," and to whom all saints and angels sing "Thou only art holy," could say in its full sense, "I am holy;" and thus the song of Moses and of the Lamb is a suitable antiphon to this Psalm, striking the mystical key-note of its Christian use. The Son of God became "poor" that He might make many rich. He was despised and rejected of men in His "misery" that He might bring many sons unto glory [Heb. ii. 10]: He was "made in the form of a servant" that He might enfranchise many from the bondage of Satan to the perfect freedom of God: He prayed as with the voice of a sinner, that bearing the sins of the whole world, He might lead forth His people "from the nethermost

THE LXXXVII PSALM.

Fundamenta ejus.

The XVII. Day. **H**ER foundations are upon the Morning holy hills : the Lord loveth the Prayer. gates of Sion more than all the dwellings of Jacob.

2 Very excellent things are spoken of thee : thou city of God.

3 I will think upon Rahab and Babylon : with them that know me.

4 Behold ye the Philistines also : and they of Tyre, with the Morians ; lo, there was he born.

5 And of Sion it shall be reported that he was born in her : and the most High shall stablish her.

6 The Lord shall rehearse it when he writeth up the people : that he was born there.

7 The singers also and trumpeters shall he rehearse : All my fresh springs shall be in thee.

Heb. xi. 10.
xii. 22.
Isa. ii. 2.
Eph. ii. 20.
Rev. xxi. 10. 12.
Matt. xvi. 18.
v. 14.
Isa. lx. 14.
Rev. xxi. 12.
Isa. xix. 18.
Heb. viii. 10.
Eph. iii. 19.
Isa. lx. 6, 7, 14.
i. e. the Moors.

Gal. iv. 19.
Rev. xii. 5.

Ezek. ix. 2, 4.
Isa. ix. 6.

John iv. 10.
Rev. vii. 15.
xxii. 1.

THE LXXXVIII PSALM.

Domine Deus.

Good Friday Evensong. Passion Psalm. **O** LORD God of my salvation, I have cried day and night before thee : O let my prayer enter into thy presence, incline thine ear unto my calling.

Hell." He thus went through all the travail of His soul that He might see "some token for good," and be "satisfied" with the mighty results of His sufferings ; that the great work of man's redemption might be accomplished ; and that hereafter the "token for good" may be showed before all men in the sign of the Son of Man which shall appear as a cross of suffering transformed into a banner of triumph ; at whose appearing "they which pierced Him" shall look on His transfigured wounds, and acknowledge Him for their Judge.

With careful and reverent reserve this Psalm may be used by the members of Christ as His voice speaking in them. The bracketed marginal references will indicate how far Christ's own words respecting Himself may be adopted by Christians respecting themselves ; and a due appreciation of this and similar Psalms in their highest sense will be the best preservative against a presumptuous application of them.

PSALM LXXXVII.

Whatever application this Psalm may originally have had to the earthly Sion has been transfigured and glorified by the subsequent Revelation of the City of God in the prophetic vision of St. John. Of the new Jerusalem it was predicted, "It shall come to pass in the last days that the mountain of the Lord's house shall be established in the top of the mountains, and shall be exalted above the hills, and all nations shall flow unto it ;" and of this St. John had a glorious vision long after the earthly Sion had been destroyed ; when "he carried me away in the spirit to a great and high mountain, and showed me that great city, the holy Jerusalem, descending out of Heaven from God,

PSALMUS LXXXVI.

FUNDAMENTA ejus in montibus sanctis : diligit Dominus portas Sion super omnia tabernacula Jacob. Friday Mattins. Circumc. Dedic. Ch., B. V. M., 2nd Noct.

Gloriosa dicta sunt de te : civitas Dei.

Memor ero Rahab et Babylonis : scientium me.

Ecce alienigenæ, et Tyrus, et populus Æthiopum : hi fuerunt illic.

Nunquid Sion dicet, Homo, et homo natus est in ea : et ipse fundavit eam Altissimus? Enter Sion . . . Jactus est

Dominus narrabit in scripturis populorum : et principum horum qui fuerunt in ea.

Sicut lætantium omnium : habitatio omnium nostrum est in te.

PSALMUS LXXXVII.

DOMINE Deus salutis meæ : in die clamavi et nocte coram te. Friday Mattins. Good Friday, 3rd Noct. Dedic. Ch., 2nd Noct. Intret in conspectu tuo oratio mea : inclina aurem tuam ad precem meam : meam Domine

having the glory of God ; and her light was like unto a stone most precious, even like a jasper stone, clear as crystal ; and had a wall great and high, and had twelve gates, and at the gates twelve angels, and names written thereon, which are the names of the twelve tribes of the children of Israel ; . . . and the wall of the city had twelve foundations, and in them the names of the twelve apostles of the Lamb." This city had already been spoken of also by St. Paul : "But ye are come to mount Sion, and unto the city of the living God, the heavenly Jerusalem," "built upon the foundation of the Apostles and Prophets, Jesus Christ Himself being the chief corner-stone ;" and to the same our Lord referred when He said, "Upon this Rock I will build My Church ; and the gates of hell shall not prevail against it." Thus the New Testament rings out a clear antiphon to this Psalm, "I saw the holy city, new Jerusalem, coming down from God, out of Heaven, prepared as a bride adorned for her husband" [Rev. xxi. 2]—a city belonging to all the peoples of the world, and in which Christ is ever being born, through the increase of His Mystical Body.

PSALM LXXXVIII.

Nothing but the Passion of our Blessed Redeemer can give the key to the mournful words of this Psalm ; and as the holy Name Jesus, though often borne by men before it was adopted by the

¹ It is pointed out by a modern commentator on the Psalms that the use of the words "spoken of" in verse 2, is identical with that in Canticles viii. 3, and has reference to betrothal, "With glorious promises He claimeth thee as His bride." [Thrupp on Psalms, ii. 90.]

The XVII. Day.
Morning
Prayer.

Isa. liii. 12.
Acts i. 26.

2 For my soul is full of trouble :
and my life draweth nigh unto hell.

3 I am counted as one of them that
go down into the pit : and I have
been even as a man that hath no
strength.

Hos. xiii. 14.

4 Free among the dead, like unto
them that are wounded, and lie in the
grave : who are out of remembrance,
and are cut away from thy hand.

5 Thou hast laid me in the lowest
pit : in a place of darkness and in the
deep.

6 Thine indignation lieth hard upon
me : and thou hast vexed me with all
thy storms.

7 Thou hast put away mine ac-
quaintance far from me : and made
me to be abhorred of them.

8 I am so fast in prison : that I
cannot get forth.

Exod. xviii. 11,
12.
Isa. xxv. 11.
i. e. all the day.

9 My sight faileth for very trouble :
Lord, I have called daily upon thee, I
have stretched forth my hands unto
thee.

10 Dost thou shew wonders among
the dead : or shall the dead rise up
again, and praise thee ?

11 Shall thy lovingkindness be
shewed in the grave : or thy faithful-
ness in destruction ?

Job x. 21, 22.
Eccl. viii. 10.
ix. 6.

12 Shall thy wondrous works be
known in the dark : and thy righte-
ousness in the land where all things
are forgotten ?

13 Unto thee have I cried, O Lord :
and early shall my prayer come before
thee.

Quia repleta est malis anima mea :
et vita mea inferno appropinquavit. *adpropinabit*

Æstimatus sum cum descendentibus
in lacum : factus sum sicut homo sine
adjutorio, inter mortuos liber.

Sicut vulnerati, dormientes in sepul- *dorm. projecti in*
chris, quorum non es memor amplius : *monumentis . . .*
et ipsi de manu tua repulsi sunt. *mementis et*
quidem ipsi . . .
expulsi

Posuerunt me in lacu inferiori : in
tenebrosis et in umbra mortis.

Super me confirmatus est furor tuus : *ira tua et omnes*
et omnes fluctus tuos induxisti super *elationes*
me.

Longe fecisti notos meos a me : po-
suerunt me abominationem sibi.

Traditus sum et non egrediebar :
oculi mei languerunt præ inopia. *infirmati sunt præ*

Clamavi ad te, Domine : tota die
expandi ad te manus meas.

Nunquid mortuis facies mirabilia :
aut medici suscitabunt, et confitebun- *resuscitabunt*
tur tibi ?

Nunquid narrabit aliquis in sepul-
chro misericordiam tuam : et veritatem
tuam in perditione ?

Nunquid cognoscentur in tenebris
mirabilia tua : et justitia tua in terra
oblivionis ?

Et ego ad te, Domine, clamavi : et
mane oratio mea præveniet te.

Saviour, can never again be reverently used by them, so if this Psalm ever expressed the personal experience of David or any other saint, it has yet now become too sacred to be applied to any but Christ : in whose Name it is sung by His Mystical Body. No other Psalm expresses so fully the profundity of the spiritual darkness which overwhelmed the soul of the suffering Jesus on the Cross, or expresses it so utterly without the breaking in upon it of one hopeful ray of light. We are almost compelled to go even further, and to receive the Psalm as a Divine revelation of a darkness beyond the Cross which is not referred to in the holy Gospel ; for all the expressions in the Psalm refer to death as past, and to the state after death as that which is present to the mind of the speaker¹.

But such an interpretation, in a literal form, seems to be inconsistent with our Lord's last words, "It is finished," and "Father, into Thy hands I commend My spirit." It is safer,

¹ The one apparent exception, verse 15, is not really so. The "point" is so placed as to interfere with the true meaning, which is, "From my youth up I have been at the point to die." See the Vulgate and the Bible Version.

therefore, to suppose that the darkness of the state after death formed part of our Lord's sufferings *by anticipation*, that the actual descent into Hell was a part of the Resurrection Victory, and that the misery of God's "wrathful displeasure" with sinners after death formed part of those unknown sufferings which were veiled by the "darkness over all the earth," and the evidence of which is condensed into the awful cry, "My God, My God, why hast Thou forsaken Me?" As the fear of death entered into His sufferings, so also did the fear of what comes after death form a part of them. Thus "I am counted as one of them that go down into the pit" may be interpreted in the same manner as "He was *numbered*² with the transgressors : " viz., that He bore all the shame of a transgressor though He was not actually one, and that, being "made sin for us," He suffered the full punishment of sin—privation of the Divine Presence—though He did not suffer during His vicarious but triumphant descent into the kingdom of Satan.

² So when Matthias was made an Apostle it is said "he was *numbered* with the eleven Apostles."

The XVII. Day. *Morning Prayer.* 14 Lord, why abhorrest thou my soul : and hidest thou thy face from me ?
Matt. xxvii. 46.

15 I am in misery, and like unto him that is at the point to die : even from my youth up; thy terrors have I suffered with a troubled mind.
[The : ought to be placed after "youth up."]

16 Thy wrathful displeasure goeth over me : and the fear of thee hath undone me.

i. e. all the day. 17 They came round about me daily like water : and compassed me together on every side.

18 My lovers and friends hast thou put away from me : and hid mine acquaintance out of my sight.

THE LXXXIX PSALM.

Misericordias Domini.

Evening Prayer. Christmas Day, Evensong.

MY song shall be alway of the loving-kindness of the Lord : with my mouth will I ever be shewing thy truth from one generation to another.

2 For I have said, Mercy shall be set up for ever : thy truth shalt thou stablish in the heavens.

Isa. lv. 3. 2 Sam. vii. 12. 14. Heb. i. 5.

3 I have made a covenant with my chosen : I have sworn unto David my servant ;

Heb. ii. 13. Rev. xxii. 16. Isa. ix. 6, 7. Luke i. 32, 33.

4 Thy seed will I stablish for ever : and set up thy throne from one generation to another.

Rev. xix. 5. xv. 3. Eph. iii. 10.

5 O Lord, the very heavens shall praise thy wondrous works : and thy truth in the congregation of the saints.

Matt. xxvi. 64.

6 For who is he among the clouds : that shall be compared unto the Lord ? 7 And what is he among the gods : that shall be like unto the Lord ?

1 Cor. viii. 5. Heb. i. 6.

8 God is very greatly to be feared in the council of the saints : and to be had in reverence of all them that are round about him.

Rev. iv. 2—11. v. 12.

9 O Lord God of hosts, who is like unto thee : thy truth, most mighty Lord, is on every side.

Ut quid, Domine, repellis orationem meam : avertis faciem tuam a me ?

Pauper sum ego et in laboribus a *Egens sum* juventute mea : exaltatus autem, humiliatus sum et conturbatus. *et confusus*

In me transierunt iræ tuæ : et terrores tui conturbaverunt me.

Circunderunt me sicut aqua tota *Circueverunt* die : circunderunt me simul.

Elongasti a me amicum et proximum : et notos meos a miseria.

PSALMUS LXXXVIII.

MISERICORDIAS Domini : in *Friday Mattins.* æternum cantabo. *Christmas, 3rd Noct.*

In generatione et generationem : *et progenie pronuntiabo* annuntiabo veritatem tuam in ore meo.

Quoniam dixisti, in æternum misericordia ædificabitur in cœlis : præparabitur veritas tua in eis.

Disposui testamentum electis meis : juravi David servo meo, Usque in æternum præparabo semen tuum.

Et ædificabo in generatione et generationem : *in sæculum sæculi* sedem tuam.

Confitebuntur cœli mirabilia tua, Domine : etenim veritatem tuam iræcclesia sanctorum.

Quoniam quis in nubibus æquabitur Domino : similis erit Deo in filiis *aut quis similis* Dei ?

Deus qui glorificatur in consilio sanctorum : magnus et terribilis super *et metuendus* omnes qui in circuitu ejus sunt.

Domine, Deus virtutum, quis similis tibi ? potens es, Domine, et veritas tua in circuitu tuo.

Beyond this general indication of the manner in which this Psalm applies to Christ's Passion it may be undesirable to go, for when once the pervading sense of it has been perceived, the details are so plain that they are scarcely in need of further explanation, and may be more reverently left without it.

PSALM LXXXIX.

This song of the Lord's loving-kindness celebrates the Nativity

of our Blessed Saviour, and the establishment of the true David's spiritual seed by virtue of His Incarnation, and of the results which followed therefrom. "For unto us a Child is born, unto us a Son is given, and the government shall be upon His shoulder; and His Name shall be called Wonderful, Counsellor, The mighty God, The everlasting Father, The Prince of Peace. Of the increase of His government and peace there shall be no end, upon the throne of David, and upon his kingdom, to order it, and to

The XVII. Day.
Evening
Prayer.
Mark iv. 39.

Rev. xi. 8.

Rev. v. 5.

Matt. xiii. 16.

Luke i. 68, 69.

1 Sam. xiii. 14.
xvi. 1. 7. 12.
Matt. xii. 18.

Acts xiii. 22.
Ezek. xxxiv. 24.
Hos. iii. 5.

John iii. 34.

John xiv. 30.

John xviii. 6.
Phil. ii. 8.
Rev. xix. 11—16.

10 Thou rulest the raging of the sea : thou stillest the waves thereof when they arise.

11 Thou hast subdued Egypt, and destroyed it : thou hast scattered thine enemies abroad with thy mighty arm.

12 The heavens are thine, the earth also is thine : thou hast laid the foundation of the round world, and all that therein is.

13 Thou hast made the north and the south : Tabor and Hermon shall rejoice in thy Name.

14 Thou hast a mighty arm : strong is thy hand, and high is thy right hand.

15 Righteousness and equity are the habitation of thy seat : mercy and truth shall go before thy face.

16 Blessed is the people, O Lord, that can rejoice in thee : they shall walk in the light of thy countenance.

17 Their delight shall be daily in thy Name : and in thy righteousness shall they make their boast.

18 For thou art the glory of their strength : and in thy lovingkindness thou shalt lift up our horns.

19 For the Lord is our defence : the Holy One of Israel is our King.

20 Thou spakest sometime in visions unto thy saints, and saidst : I have laid help upon one that is mighty ; I have exalted one chosen out of the people.

21 I have found David my servant : with my holy oil have I anointed him.

22 My hand shall hold him fast : and my arm shall strengthen him.

23 The enemy shall not be able to do him violence : the son of wickedness shall not hurt him.

24 I will smite down his foes before his face : and plague them that hate him.

Tu dominaris potestati maris : motum autem fluctuum ejus tu mitigas.

Tu humiliasti, sicut vulneratum, superbum : in brachio virtutis tuæ distulisti inimicos tuos. in virtute brachii tui

Tui sunt cœli, et tua est terra : orbem terræ et plenitudinem ejus tu fundasti ; aquilonem et mare tu creasti.

Thabor et Hermon in Nomine tuo exsultabunt : tuum brachium cum potentia.

Firmetur manus tua, et exaltetur dextera tua : justitia et judicium præparatio sedis tuæ.

Misericordia et veritas præcedent faciem tuam : beatus populus, qui scit jubilationem. præibunt ante

Domine, in lumine vultus tui ambulabunt, et in Nomine tuo exsultabunt tota die : et in justitia tua exaltabuntur.

Quoniam gloria virtutis eorum tu es : et in beneplacito tuo exaltabitur cornu nostrum.

Quia Domini est assumptio nostra : et sancti Israël Regis nostri.

Tunc locutus es in visione sanctis tuis : et dixisti, Posui adjutorium in potente, et exaltavi electum de plebe mea. in aspectu filii tuis

Inveni David servum meum : oleo sancto meo unxi eum.

Manus enim mea auxiliabitur ei : et brachium meum confortabit eum.

Nihil proficiet inimicus in eo : et filius iniquitatis non apponet nocere ei. non nocet ei

Et concidam a facie ipsius inimicos ejus : et odientes eum in fugam convertam.

establish it with judgment and with justice, from henceforth, even for ever." "I will make an everlasting covenant with you, even the sure mercies of David." "He shall be great, and shall be called the Son of the Highest, and the Lord God shall give unto Him the throne of His father David : and He shall reign over the house of Jacob for ever : and of His Kingdom there shall be no end."

Thus the Psalm praises God, first for the fulfilment of His promise in raising up a Messiah from the seed of David ; and secondly, for establishing the seed of the Messiah Himself in a perpetual succession from one generation to another. It is also to be

understood, in part, as a song of praise to Christ Himself, Whose wondrous works, in His Incarnation, Resurrection, and Ascension, the very heavens praised by the mouth of holy Angels. In this sense we see how fully the Divine glory of "the Man Christ Jesus" is illustrated by the voice of prophecy. When St. Paul writes, "But to which of the angels said He at any time, Sit on My right hand, until I make Thine enemies Thy footstool?" he does but take up the tone of David, "Who is He among the clouds that shall be compared unto the Lord? And what is He among the gods that shall be like unto the Lord?" So also, when the Evangelical record tells us that Jesus "arose and

The XVII. Day. <i>Evening Prayer.</i>	25 My truth also and my mercy shall be with him : and in my Name shall his horn be exalted.	Et veritas mea et misericordia mea cum ipso : et in Nomine meo exaltabitur cornu ejus.
Isa. xlix. 6. Zech. ix. 10.	26 I will set his dominion also in the sea : and his right hand in the floods.	Et ponam in mari manum ejus : et in fluminibus dexteram ejus.
2 Sam. vii. 14. Luke i. 32.	27 He shall call me, Thou art my Father : my God, and my strong salvation.	Ipsè invocavit me, Pater meus es <i>invocabit</i> tu : Deus meus, et susceptor salutis meæ.
Matt. iii. 17. Col. i. 18.	28 And I will make him my first-born : higher than the kings of the earth.	Et ego primogenitum ponam illum : excelsum præ regibus terræ.
	29 My mercy will I keep for him for evermore : and my covenant shall stand fast with him.	In æternum servabo illi misericordiam meam : et testamentum meum fidele ipsi.
1 Sam. vii. 13. Isa. ix. 7. Hii. 10.	30 His seed also will I make to endure for ever : and his throne as the days of heaven.	Et ponam in sæculum sæculi semen ejus : et thronum ejus sicut dies cœli. <i>sedem ejus</i>
Isa. viii. 18.	31 But if his children forsake my law : and walk not in my judgments ;	Si autem dereliquerint filii ejus legem meam : et in judiciis meis non ambulaverint.
1 Sam. vii. 14. Heb. xii. 6. 10.	32 If they break my statutes, and keep not my commandments : I will visit their offences with the rod, and their sin with scourges.	Si justitias meas profanaverint : et <i>justificationes</i> mandata mea non custodierint.
1 Sam. vii. 15.	33 Nevertheless, my lovingkindness will I not utterly take from him : nor suffer my truth to fail.	Misericordiam autem meam non dispergam ab eo : neque nocebo in veritate mea.
	34 My covenant will I not break, nor alter the thing that is gone out of my lips : I have sworn once by my holiness, that I will not fail David.	Neque profanabo testamentum meum : et quæ procedunt de labiis meis non faciam irrita.
1 Sam. vii. 16.	35 His seed shall endure for ever : and his seat is like as the sun before me.	Semel juravi in sancto meo, si David mentiar : semen ejus in æternum manebit.
Isa. lv. 4. Rev. i. 5.	36 He shall stand fast for evermore as the moon : and as the faithful witness in heaven.	Et thronus ejus sicut sol in conspectu meo : et sicut luna perfecta in æternum, et testis in cœlo fidelis. <i>sedes ejus</i>
Ps. xlv. 7. Matt. xxvii. 46.	37 But thou hast abhorred and forsaken thine Anointed : and art displeased at him.	Tu vero repulisti et despexisti : distulisti Christum tuum. <i>et sprevisisti</i>
Cf. Ps. cxxxii. 19.	38 Thou hast broken the covenant of thy servant : and cast his crown to the ground.	Evertisti testamentum servi tui : profanasti in terra sanctuarium ejus. <i>avertisti sanctitatem ejus</i>

rebuked the wind, and said unto the sea, Peace, be still ; and the wind ceased, and there was a great calm :” the words are as distinct an historical comment on “Thou rulest the raging of the sea, Thou stillest the waves thereof when they arise,” as is the account given in Exodus of the Passage of the Red Sea. Hence in this first section of the Psalm there is much of mystical application to our Lord : and we may interpret the eighth verse of the worship given by all the saints and angels to “the Lamb as it had been slain,” the eleventh verse of the subjugation of Antichrist, the twelfth of that final glory of Christ, when “all things shall be put under His feet.”

The twentieth verse begins another section in which the Church, or rather Christ in the Person of His Mystical Body, recounts the ancient promises of God respecting the establishment of the Messiah and His Kingdom. These promises had a partial relation to David himself, but there is very much in them which is clearly typical, and relating to Him Who was “chosen out of the people” by being born of the Virgin Mary, “anointed” with the Holy Ghost at His Baptism in Jordan, declared to be the “First-born” of God by the Voice from Heaven, “This is My beloved Son,” made “higher than the kings of the earth” by His reign over a Kingdom which embraces all kingdoms, to Whom is given a

The XVII. Day.
*Evening
Prayer.*
Isa. v. 5.

39 Thou hast overthrown all his hedges : and broken down his strong holds.

40 All they that go by spoil him : and he is become a reproach to his neighbours.

41 Thou hast set up the right hand of his enemies : and made all his adversaries to rejoice.

42 Thou hast taken away the edge of his sword : and givest him not victory in the battle.

43 Thou hast put out his glory : and cast his throne down to the ground.

Cf. Hos. vii. 9.

44 The days of his youth hast thou shortened : and covered him with dishonour.

Job xiii. 24.

45 Lord, how long wilt thou hide thy self, for ever : and shall thy wrath burn like fire?

46 O remember how short my time is : wherefore hast thou made all men for nought?

1 Cor. xv. 22.

47 What man is he that liveth, and shall not see death : and shall he deliver his soul from the hand of hell?

Isa. lv. 3.

48 Lord, where are thy old loving-kindnesses : which thou swarest unto David in thy truth?

Ps. lxi. 21.
Rev. iii. 19.
Isa. llii. 4. 5.
Acts ix. 4. 5.

49 Remember, Lord, the rebuke that thy servants have : and how I do bear in my bosom the rebukes of many people;

Rev. xix. 6.

50 Wherewith thine enemies have blasphemed thee, and slandered the footsteps of thine Anointed : Praised be the Lord for evermore. Amen, and Amen.

Destruixisti omnes sepes ejus : po- maaherias ejus
suisti firmamentum ejus formidinem. munitiones ejus
in formidine

Diripuerunt eum omnes transeuntes viam : factus est opprobrium vicinis suis.

Exaltasti dexteram deprimentium inimicorum ejus eum : lætificasti omnes inimicos ejus.

Avertisti adjutorium gladii ejus : et non es auxiliatus ei in bello.

Destruixisti eum ab emundatione : et Dissolvisti sedem ejus in terram collisisti.

Minorasti dies temporis ejus : perfudisti eum confusione.

Usquequo, Domine, avertis in finem : irascaris exardescet sicut ignis ira tua?

Memorare quæ mea substantia : Domine que nunquid enim vane constituisti omnes non enim ...
(omnes) filios hominum?

Quis est homo qui vivet, et non videbit mortem : eruet animam suam aut quis eruet de manu inferi?

Ubi sunt misericordiæ tuæ antiquæ, Domine : sicut jurasti David in veritate tua?

Memor esto, Domine, opprobrii servorum tuorum : quod continui in sinu meo multarum gentium.

Quod exprobraverunt inimici tui, Domine : quod exprobraverunt commutationem Christi tui.

Benedictus Dominus in æternum : Fiat, Fiat.

“seed” that “shall endure for ever,” and a throne “like as the sun” in its glory and stability before God.

After recounting these promises, there is a transition in the thirty-seventh verse to a strain which is that of a Passion Psalm. Coming where it does, this strain illustrates the fact that Christ's whole life on earth was one of deep humiliation, and that the Incarnation itself was the first step towards the Cross. Except in the last few words, the remainder of the Psalm all takes this sad tone, and it is, thus, much in keeping with the tone of our Lord's personal feelings so far as they are revealed to us in the Gospels. It is impossible to explain how His holy mind could have been so filled with what in ordinary persons we should call despondency, when the glorious end of all must have been visible to Him. Yet the fact is plain in the Gospel narrative, and the latter portion of this Psalm, written concerning Him, is an inspired confirmation of the fact. Such depression and despondency has not unfrequently come upon the Church of Christ also

at certain periods of her history : and a time will probably arrive when, as “the very elect” will be, “if it were possible,” deceived by “false Christs,” so they will be driven almost to despair of God's promise that the gates of hell shall not prevail against His Church.

The concluding burst of praise (the Doxology of the third Book) which makes a new and so sudden a transition from the sorrow of the preceding verses is, more or less, common to nearly all the Psalms which set forth the humiliation and suffering of our Lord. “Heaviness may endure for a night, but joy cometh in the morning :” and the morning of the Resurrection brought its earliest rays of Light to the garden tomb. As the triumph and glory of Christ followed immediately on His greatest humiliation and suffering, so after the last depression and persecution of His Mystical Body the Light of God and the Lamb will shine upon her, and with unceasing joy the Bride will sing, “Alleluia, for the Lord God Omnipotent reigneth.”

THE XC PSALM.

Domine, refugium.

The XVIII.
Day.
Morning
Prayer.
Burial of the
dead.
Gen. i. 1.
John i. 1.

LORD, thou hast been our refuge :
from one generation to another.

2 Before the mountains were brought
forth, or ever the earth and the world
were made : thou art God from ever-
lasting, and world without end.

3 Thou turnest man to destruction :
again thou sayest, Come again, ye
children of men.

4 For a thousand years in thy sight
are but as yesterday : seeing that is
past as a watch in the night.

5 As soon as thou scatterest them
they are even as a sleep : and fade
away suddenly like the grass.

6 In the morning it is green, and
groweth up : but in the evening it is
cut down, dried up, and withered.

7 For we consume away in thy dis-
pleasure : and are afraid at thy wrath-
ful indignation.

8 Thou hast set our misdeeds before
thee : and our secret sins in the light
of thy countenance.

9 For when thou art angry all our
days are gone : we bring our years to
an end, as it were a tale that is told.

10 The days of our age are three-
score years and ten¹; and though men
be so strong that they come to four-
score years : yet is their strength then
but labour and sorrow; so soon passeth
it away, and we are gone.

11 But who regardeth the power of
thy wrath : for even thereafter as a
man feareth, so is thy displeasure.

Gen. iii. 19.
1 Cor. xv. 22.

2 Pet. iii. 8.
Numb. xiv. 34.
Ezek. ii. 4. 6.

Job xiv. 10.

Ecc. i. 4.
Isa. xl. 6. 8.
1 Pet. i. 25.

Job xiv. 1.
James iv. 14.

Rom. v. 12.

Job xiv. 13.

Gen. xlvii. 9.
1 Kings i. 1.
Ecc. ii. 22, 23.

PSALMUS LXXXIX.

DOMINE, refugium factus es no- Thursd. Lauds.
bis : a generatione in genera- *et progenie*
tionem.

Priusquam montes fierent, aut for- *firmaretur*
maretur terra et orbis : a sæculo et
usque in sæculum tu es Deus.

Ne avertas hominem in humili-
tatem : et dixisti, Convertimini filii
hominum.

Quoniam mille anni ante oculos
tuos : tanquam dies hesterna, quæ
præterit.

Et custodia in nocte : quæ pro ni- *Et sicut*
hilo habentur, eorum anni erunt.

Mane sicut herba transeat, mane
floreat et transeat : vespere decidat,
induret, et arescat.

Quia defecimus in ira tua : et in
furore tuo turbati sumus.

Posuisti iniquitates nostras in con-
spectu tuo : sæculum nostrum in illu-
minatione vultus tui.

Quoniam omnes dies nostri defece-
runt : et in ira tua defecimus.

Anni nostri sicut aranea meditabun- *meditabantur*
tur : dies annorum nostrorum, in ipsis
septuaginta anni.

Si autem in potentatibus octoginta
anni : et amplius eorum labor et dolor. *plurimum*

Quoniam supervenit mansuetudo : *supervenit super*
et corripimur. *nos*

Quis novit potestatem iræ tuæ : et
præ timore tuo iram tuam dinumerare?

THE FOURTH BOOK.

PSALM XC.

The title of this Psalm is "a prayer of Moses the servant of
God," and there is no reason to suppose otherwise than that it
comes down from him. It seems to be a typical intercession of
the typical mediator, uttered in view of that revelation of the
Fall of man, and of the sentence, "Dust thou art, and unto dust
shalt thou return," which is recorded in the Book of Genesis : and

¹ Moses himself lived to the age of 120, and was then in full vigour.
[Deut. xxxii. 7.] But the forty years which Israel spent in the wilderness
appears to have been the extreme limit of a generation : and we may, there-
fore, conclude that "threescore years and ten" was the average age of
mankind even in the time of Moses, and that his case was of an exceptional,
perhaps miraculous, character.

the second verse confirms this view by its striking analogy with
the opening of that book. It may be, also, that the third verse
is the prophet's contemplation of God's promise to Eve that One
should arise of her descendants who should bruise the head of the
Tempter, and thus open the gates of Paradise for the return of
the children of men. It may be, also, that a dim foreshadowing
of the time when Christ should appear is indicated by the fourth
verse, though the Psalm was probably written about fifteen hun-
dred years before His Advent².

² St. Barnabas quotes the fourth as one indication among others that the
world will last for 6060 years in its present condition. "Therefore, my
children," he adds, "in six days, that is in the six thousand years, all things
shall be finished. And He rested on the seventh day : this means, when
His Son shall come, and shall abolish the time of the Wicked One," [Anti-
christ,] "and shall judge the ungodly, and shall change the sun and moon
and stars. Then shall He rest gloriously on the seventh day."

The XVIII.
Day.
Morning
Prayer.
at. O teach us.
Job xiv. 5, 6.

12 So teach us to number our days :
that we may apply our hearts unto
wisdom.

13 Turn thee again, O Lord, at the
last : and be gracious unto thy ser-
vants.

14 O satisfy us with thy mercy,
and that soon : so shall we rejoice and
be glad all the days of our life.

Job xiv. 15.
Luke xvi. 25.

15 Comfort us again now after the
time that thou hast plagued us : and
for the years wherein we have suffered
adversity.

Exod. xxiii. 18.
John xi. 25, 40.

16 Shew thy servants thy work :
and their children thy glory.

1 Cor. xv. 49, 58.
Eccl. ix. 10.
Rev. xxi. 11.

17 And the glorious Majesty of the
Lord our God be upon us : prosper
thou the work of our hands upon us,
O prosper thou our handy-work.

THE XCI PSALM.

Qui habitat.

WHOSO dwelleth under the de-
fence of the most High : shall
abide under the shadow of the Al-
mighty.

2 I will say unto the Lord, Thou
art my hope, and my strong hold : my
God, in him will I trust.

1 Tim. iii. 7.
Cf. Ezek. xiii. 18.
20.

3 For he shall deliver thee from the
snare of the hunter : and from the
noisome pestilence.

Matt. xxiii. 37.

4 He shall defend thee under his
wings, and thou shalt be safe under
his feathers : his faithfulness and truth
shall be thy shield and buckler.

Prov. iii. 24.
Eph. vi. 16.

5 Thou shalt not be afraid for any
terror by night : nor for the arrow
that flieth by day ;

Dexteram tuam sic notam fac : et *Domine notam
fac nobis*
eruditos corde in sapientia.

Convertere, Domine, usquequo : et *Domine aliquan-
tulum et depre-
care super*
deprecabilis esto super servos tuos.

Repleti sumus mane misericordia
tua : et exultavimus et delectati sumus
omnibus diebus nostris.

Lætati sumus pro diebus quibus nos *Delectati*
humiliasti : annis quibus vidimus
mala.

Respice in servos tuos et in opera *op. tua Domine*
tua : et dirige filios eorum.

Et sit splendor Domini Dei nostri
super nos ; et opera manuum nostra-
rum dirige super nos : et opus manuum
nostrarum dirige.

PSALMUS XC.

QUI habitat in adjutorio Altissimi : *Compline.
All Saints,
Mattins,
2nd Noct.
Dedic. Ch.,
3rd Noct.*
in protectione Dei cœli commo-
rabitur.

Dicet Domino, Susceptor meus es
tu, et refugium meum : Deus meus,
sperabo in eum.

Quoniam ipse liberavit me de laqueo *liberabit*
venantium : et a verbo aspero.

Scapulis suis obumbrabit tibi : et
sub pennis ejus sperabis.

Scuto circumdabit te veritas ejus :
non timebis a timore nocturno.

Even at this early date, God thus revealed to all to whom the words of this Psalm came the Evangelical truth more fully declared in after ages, that death is not a natural circumstance, belonging to the constitution of the human body and soul ; but that it is a consequence of sin : "By one man sin entered into the world, and death by sin, and so death passed upon all men, for that all have sinned." [Rom. v. 12.] It is a truth which is likely to be brought into discredit in an age when physiological studies are not so much tempered as they ought to be by theological studies : but yet a truth which no physiological research can disprove, and which Holy Scripture distinctly asserts. Man does not die because it is a necessary part of his nature to wear out ; but because the decree has gone forth, "Dying, thou shalt die." [Gen. ii. 17.] The key-note, or Antiphon, of this Psalm is, then, to be found in the words of Isaiah, partly adopted by St. Peter : "The Voice said, Cry. And he said, What shall I cry ? All flesh is grass, and all the goodliness thereof is as the flower of the field. The grass withereth, the flower fadeth, because the Spirit of the Lord

bloweth upon it : surely the people is grass. The grass withereth, and the flower fadeth, but the Word of our God shall stand for ever." Blessed be God that a further revelation also has been made to us, "I am the Resurrection and the Life : he that believeth in Me, though he were dead, yet shall he live : and whosoever liveth and believeth in Me shall never die." "Said I not unto thee, that, if thou wouldest believe, thou shouldst see the glory of God ?"

PSALM XCI.

When the Tempter misquoted¹ the eleventh and twelfth verses of this Psalm, he was the means of giving us evidence that it is spoken of Christ, for the holy Jesus did not contradict the application of it to Himself, but rebuked the wrong application of it¹.

¹ As Satan distorted God's command to our first parents, so he omitted "in all Thy ways,"—the ways of Christ's work and duty,—in quoting these verses.

The XVIII.
Day.
Morning
Prayer.
Nos. xiii. 14.
1 Cor. xv. 55.

6 For the pestilence that walketh in darkness : nor for the sickness that destroyeth in the noon-day.

7 A thousand shall fall beside thee, and ten thousand at thy right hand : but it shall not come nigh thee.

8 Yea, with thine eyes shalt thou behold : and see the reward of the ungodly.

John xix. 11.

9 For thou, Lord, art my hope : thou hast set thine house of defence very high.

10 There shall no evil happen unto thee : neither shall any plague come nigh thy dwelling.

Luke xxii. 49.
Matt. xxvi. 53.
Luke iv. 9—11.
Heb. i. 14.

11 For he shall give his angels charge over thee : to keep thee in all thy ways.

12 They shall bear thee in their hands : that thou hurt not thy foot against a stone.

1 Pet. v. 8.
Gen. iii. 15.
Rev. xiii. 2.
xx. 1—3.

13 Thou shalt go upon the lion and adder : the young lion and the dragon shalt thou tread under thy feet.

14 Because he hath set his love upon me, therefore will I deliver him : I will set him up, because he hath known my Name.

Acts vii. 56.
Rev. v. 8—14.

15 He shall call upon me, and I will hear him : yea, I am with him in trouble ; I will deliver him, and bring him to honour.

Rev. i. 18.

16 With long life will I satisfy him : and shew him my salvation.

THE XCII PSALM.

Bonum est confiteri.

IT is a good thing to give thanks unto the Lord : and to sing praises unto thy Name, O most Highest ;

A sagitta volante in die, a negotio perambulante in tenebris : ab incursu, a ruina et et dæmonio meridiano.

Cadent a latere tuo mille, et decem millia a dextris tuis : ad te autem non *tibi autem non adpropinquabit*

Veruntamen oculis tuis considerabis : et retributionem peccatorum videbis.

Quoniam tu es, Domine, spes mea : Altissimum posuisti refugium tuum. *posui*

Non accedet ad te malum : et flagellum non appropinquabit tabernaculo tuo. *adpropinquabit*

Quoniam angelis suis mandavit de *mandabit* te : ut custodiant te in omnibus viis tuis.

In manibus portabunt te : ne forte *ne unquam* offendas ad lapidem pedem tuum.

Super aspidem et basiliscum ambulabis : et conculcabis leonem et draconem.

Quoniam in me speravit, liberabo *sperabit et* eum : protegam eum, quoniam cognovit Nomen meum.

Clamabit ad me, et ego exaudiam *Invocabit me* eum : cum ipso sum in tribulatione ; eripiam eum et glorificabo eum.

Longitudine dierum replebo eum : *adimplebo* et ostendam illi salutare meum.

PSALMUS XCI.

BONUM est confiteri Domino : et *Saturday Lauds.* psallere Nomini tuo, Altissime.

Amidst the frequent changes of pronouns which occur, it may yet be clearly discerned that the Psalm is substantially a continuous promise of GOD to the Beloved Son in Whom He is well pleased. The literal figure of the first and fourth verses looks, doubtless, towards the Mercy-seat over which the wings of the Cherubim were spread forth : but mystically it looks to that unity of the First and Second Person of the Blessed Trinity which St. John speaks of when he writes, "the only begotten Son, which is in the bosom of the Father." [John i. 18.] For this dwelling under the defence of the Most High and abiding under the shadow of the Almighty was the strength and safety of our Lord's Human Nature. Thus He was delivered from the snares which the devil laid for Him in the Temptation : having been already delivered by His Immaculate Conception from the "noisome pestilence" of original sin. Thus the "fiery darts" of the Evil One were shot against Him in vain. Thus, though a thousand fell beside Him

and ten thousand at His right hand by the sting of death, that pestilence came not nigh Him, for He was able to say, "O death, I will be Thy plagues." Thus, also, did He withstand the "roaring lion" who goeth about seeking whom he may devour : thus did He bruise the head of the "adder" : and thus, hereafter, will He tread under His feet "the Dragon, that old serpent, which is the Devil," in His final glorious victory over all that is evil.

And since He vouchsafes to make such an intimate union as He does make between Himself and His Church, therefore these promises that were made primarily to Him, the Bridegroom, may be taken as applicable, in a secondary degree, to her, the Bride. "Clothed with the Sun" of Righteousness, she will eventually tread down under her feet the symbol and the power of Antichrist, she will be brought to honour in the Presence of her Lord, and "having the glory of God," notwithstanding all the dangers and persecutions through which she will have to pass.

The XVIII.
Day.
Morning
Prayer.
Lam. iii. 23.

2 To tell of thy lovingkindness early in the morning : and of thy truth in the night-season ;

3 Upon an instrument of ten strings, and upon the lute : upon a loud instrument, and upon the harp.

4 For thou, Lord, hast made me glad through thy works : and I will rejoice in giving praise for the operations of thy hands.

Isa. lv. 19.
Rom. xi. 33.

5 O Lord, how glorious are thy works : thy thoughts are very deep.

6 An unwise man doth not well consider this : and a fool doth not understand it.

Isa. xl. 6—8.
1 Pet. i. 25.

7 When the ungodly are green as the grass, and when all the workers of wickedness do flourish : then shall they be destroyed for ever ; but thou, Lord, art the most Highest for evermore.

8 For lo, thine enemies, O Lord, lo, thine enemies shall perish : and all the workers of wickedness shall be destroyed.

Luke i. 69.
Ps. cxxxii. 17.

9 But mine horn shall be exalted like the horn of an unicorn : for I am anointed with fresh oil.

10 Mine eye also shall see his lust of mine enemies : and mine ear shall hear his desire of the wicked that arise up against me.

Hos. xiv. 5—7.
Ezek. xl. 16. 26.
31. xii. 18.

11 The righteous shall flourish like a palm-tree : and shall spread abroad like a cedar in Libanus.

Rev. xxii. 2.

12 Such as are planted in the house of the Lord : shall flourish in the courts of the house of our God.

John xv. 2.

13 They also shall bring forth more fruit in their age : and shall be fat and well-liking.

Ps. i. 3.

14 That they may shew how true the Lord my strength is : and that there is no unrighteousness in him.

Ad annuntiandum mane misericordiam tuam : et veritatem tuam per noctem.

In decachordo psalterio : cum cantico, in cithara.

Quia delectasti me, Domine, in factura tua : et in operibus manuum tuarum exultabo.

Quam magnificata sunt opera tua, Domine : nimis profundæ factæ sunt cogitationes tuæ.

Vir insipiens non cognoscet : et stultus non intelliget hæc.

Cum exorti fuerint peccatores sicut fenum : et apparuerint omnes qui operantur iniquitatem :

Ut intereant in sæculum sæculi : tu autem Altissimus in æternum, Domine.

Quoniam, ecce, inimici tui, Domine, (quoniam ecce inimici tui) quoniam, ecce, inimici tui peribunt : et dispergentur omnes qui operantur iniquitatem.

Et exaltabitur sicut unicornis cornu meum : et senectus mea in misericordia uberi.

Et despexit oculus meus inimicos respexit meos : et insurgentibus in me malignantibus audiet auris mea. audivit auris tua

Justus ut palma florebit : sicut cedrus Libani multiplicabitur.

Plantati in domo Domini : in atriis domus Dei nostri florebut.

Adhuc multiplicabuntur in senecta uberi : et bene patientes erunt, ut annuntient,

Quoniam rectus Dominus Deus nos- justus ter : et non est iniquitas in eo.

PSALM XCII.

The title, "a Psalm and song for the Sabbath day," points out this to be a song of the Church during that rest upon which she has already, in some degree, entered, and in anticipation of the great Sabbath when she will enjoy complete rest from her warfare with sin : the "rest that remaineth for the people of God."

The Psalm has an Eucharistic character, the twelfth and thirteenth verses especially pointing to the Sacramental life out of which the eternal life of Heaven will spring. In the ninth verse, also, there is a reference to that anointing which ever looks, in the Psalms, to the work of the Holy Ghost, and to His Presence

with the Mystical Body of Christ. He Himself was "anointed with the oil of gladness above His fellows:" but of His members it is also said, "Ye have an unction from the Holy One" [1 John ii. 20] : and their song, at the last, is an Evangelical paraphrase of this ninth verse, "Thou hast made us unto our God kings and priests." [Rev. v. 10.]

The concluding verses of the Psalm speak of the mystical Tree of Life so often referred to in this and in other parts of Holy Scripture. Our Lord adopts the figure of the Vine : here it is the palm and the cedar, the one renowned as providing food in extraordinary abundance, the other noted for beauty and strength. In each case the one Root, Stem, and Branch are signified ; Him

THE XCIII PSALM.

Dominus regnavit.

The XVIII. **T**HE Lord is King, and hath put
Day. on glorious apparel : the Lord
Evening. hath put on his apparel, and girded
Prayer. himself with strength.
Isa. lxiii. 1. 5.
Rev. i. 13—16. 18.
Rev. xxi. 1. 2 He hath made the round world
so sure : that it cannot be moved.
Heb. i. 8. 3 Ever since the world began hath
thy seat been prepared : thou art from
everlasting.
Luke vi. 48. 4 The floods are risen, O Lord, the
floods have lift up their voice : the
floods lift up their waves.
Rom. viii. 35—39. 5 The waves of the sea are mighty,
and rage horribly : but yet the Lord,
who dwelleth on high, is mightier.
Rev. xxi. 27. 6 Thy testimonies, O Lord, are very
sure : holiness becometh thine house
for ever.

THE XCIV PSALM.

Deus ultionum.

Deut. xxxii. 35.
Heb. x. 30.
Matt. xxvi. 64.
Rev. vi. 10. **O** LORD God, to whom vengeance
belongeth : thou God, to whom
vengeance belongeth, shew thyself.
2 Arise, thou Judge of the world :
and reward the proud after their
deserving.
3 Lord, how long shall the ungodly :
how long shall the ungodly triumph ?
2 Pet. iii. 3, 4. 4 How long shall all wicked doers
speak so disdainfully : and make such
proud boasting ?

PSALMUS XCII.

DOMINUS regnavit; decorem in-
dutus est : indutus est Dominus
fortitudinem, et præcinxit se.
Sund. and Fest.
Lauds.
regnabit decorem
indutus : indutus
præcinxit se
virtutem
Etenim firmavit orbem terræ; qui
non commovebitur.
Parata sedes tua ex tunc : a sæculo
tu es.
Elevaverunt flumina, Domine : ele-
vaverunt flumina vocem suam.
Elevaverunt flumina fluctus suos : a
vocibus aquarum multarum.
Mirabiles elationes maris : mirabilis
in altis Dominus.
in excelsis
Testimonia tua credibilia facta sunt tua Domine
nimis : domum tuam decet sanctitudo,
Domine, in longitudinem dierum.
Domui tuæ decet
sancta

PSALMUS XCIII.

DEUS ultionum Dominus : Deus
ultionum libere egit.
Friday Mattins.
Good Friday,
3rd Noct.
Exaltare qui judicas terram : redde
retributionem superbis.
Usquequo peccatores, Domine : us-
quequo peccatores gloriabuntur :
Effabuntur, et loquentur iniquita-
tem : loquentur omnes qui operantur
injustitiam ?
Pronuntiabunt et

from Whom the Israel of God alone derive Life, strength, and glory. "I will be as the dew unto Israel: he shall grow as the lily, and cast forth his roots as Lebanon. His branches shall spread, and his beauty shall be as the olive-tree, and his smell as Lebanon. They that dwell under his shadow shall return: they shall revive as the Corn, and grow as the Vine: the scent thereof shall be as the wine of Lebanon."

PSALM XCIII.¹

The magnificent opening of this Psalm indicates the beginning of a series of which the 100th Psalm is the last, and in which (designedly or accidentally) the Advent of our Lord and His Kingship are the continued subjects of praise. As God He was supreme from eternity: but when He put on the apparel of His Human Nature He girded Himself with strength to become the Saviour of mankind; and, when that apparel became glorious by His Resurrection, to become King of kings and Lord of lords. "Who is this that cometh from Edom, with dyed garments from

¹ The Septuagint title of the 93rd Psalm assigns it to "the day before the Sabbath, when the earth was founded." St. Augustine connects this title with the subject of the Psalm by reminding his hearers that on the sixth day God created man in His own Image, and that our Lord's Incarnation began the sixth age of the world.

Bozrah? this that is glorious in His apparel, travelling in the greatness of His strength? I that speak in righteousness, mighty to save." . . . "I looked, and there was none to help; and I wondered that there was none to uphold: therefore Mine own arm brought salvation unto Me: and My fury, it upheld Me."

By that Advent and Incarnation the King of kings "hath made the round world" of His spiritual Kingdom "so sure that it cannot be moved" from the Rock on which He has founded it, and the gates of Hell cannot prevail against it. The floods of the sea of this world "beat vehemently upon that House," but it is founded on a Rock: and within its walls is that throne of everlasting dominion which was prepared ever since the world began in the loving purpose of an all-pitying God to become the Saviour of man. Amid all the trouble that may fall on the Church, the immoveability of her foundation and the eternal Royalty of her Head will be her true consolation and support. "In the world ye shall have tribulation: but be of good comfort; I have overcome the world." [John xvi. 33.]

PSALM XCIV.

The first act of Christ's final sovereignty will necessarily be the judgment and subjugation of those who oppose His Kingdom. His own words declare the nature of His Second Advent and

The XVIII.
Day.
Evening
Prayer.

5 They smite down thy people, O Lord : and trouble thine heritage.

6 They murder the widow and the stranger : and put the fatherless to death.

7 And yet they say, Tush, the Lord shall not see : neither shall the God of Jacob regard it.

1 Thess. v. 3.

8 Take heed, ye unwise among the people : O ye fools, when will ye understand ?

Isa. lix. 1.

9 He that planted the ear, shall he not hear : or he that made the eye, shall he not see ?

10 Or he that nutureth the heathen : it is he that teacheth man knowledge, shall not he punish ?

1 Cor. iii. 20.

11 The Lord knoweth the thoughts of man : that they are but vain..

Heb. xii. 2.

12 Blessed is the man whom thou chastenest; O Lord : and teachest him in thy law ;

Luke xxi. 19.
Heb. x. 36.
2 Thess. i. 4—10.
Rev. xvii. 8.
xx. 14.

13 That thou mayest give him patience in time of adversity : until the pit be digged up for the ungodly.

14 For the Lord will not fail his people : neither will he forsake his inheritance ;

15 Until righteousness turn again unto judgement : all such as are true in heart shall follow it.

16 Who will rise up with me against the wicked : or who will take my part against the evil-doers ?

2 Thess. ii. 16, 17.

17 If the Lord had not helped me : it had not failed but my soul had been put to silence.

18 But when I said, My foot hath slipped : thy mercy, O Lord, held me up.

Luke xxiii. 46.
Acts vii. 56.

19 In the multitude of the sorrows that I had in my heart : thy comforts have refreshed my soul.

Populum tuum, Domine, humiliaverunt : et hæreditatem tuam vexaverunt.

Viduam et advenam interfecerunt : et pupillos occiderunt.

Et dixerunt, Non videbit Dominus : nec intelliget Deus Jacob.

Intelligite insipientes in populo : et stulti aliquando sapite.

Qui plantavit aurem, non audiet ? aut qui finxit oculum, non considerat ?

Qui corripit gentes, non arguet ? qui docet hominem scientiam ?

Dominus scit cogitationes hominum : quoniam vanæ sunt.

Beatus homo quem tu erudieris, Domine : et de lege tua docueris eum.

Ut mitiges ei a diebus malis : donec fodiatur peccatori fovea.

Quia non repellet Dominus plebem suam : et hæreditatem suam non derelinquet.

Quoadusque justitia convertatur in judicium : et qui juxta illam omnes qui recto sunt corda. et qui timent eam omnes

Quis consurget mihi adversus malignantes ? aut quis stabit mecum adversus operantes iniquitatem. casurget

Nisi quia Dominus adjuvit me : paulominus habitasset in inferno anima mea. quod Dominus adjuvasset

Si dicebam, Motus est pes meus : misericordia tua, Domine, adjuvabat me.

Secundum multitudinem dolorum meorum in corde meo : consolationes tuæ lætificaverunt animam meam. tuæ Domine

manifestation, "Hereafter shall ye see the Son of Man sitting on the right hand of power, and coming in the clouds of heaven : " the opening words of the Revelation declare, "Behold, He cometh with clouds ; and every eye shall see Him, and they also which pierced Him : and all kindreds of the earth shall wail because of Him. Even so, Amen" [Rev. i. 7] : and the prophet of the New Dispensation heard the martyrs using almost the words with which this Psalm opens, when "they cried with a loud voice, saying, How long, O Lord, holy and true, dost Thou not judge and avenge our blood on them that dwell on the earth ? " This Psalm, therefore, is the call of the Church to Christ to fulfil her constant prayer, "Thy Kingdom come," and the antecedent of her great Eucharistic hymn,— "We give Thee thanks, O Lord

God Almighty, Which art, and wast, and art to come ; because Thou hast taken to Thee Thy great power, and hast reigned." [Rev. xi. 17.]

That events will occur shortly before our Lord's Second Advent which will cause the Church of God to cry out in anguish for Christ to hasten His Kingdom and to judge her cause against the great Persecutor of that time, our Lord Himself revealed in His last discourse to the Apostles before His suffering. A constant tradition of the Christian world has also been maintained to the same effect. No doubt the full application of this Psalm will be revealed when that time arrives, a time when the faith and patience of Christians will be tried to the uttermost.

But, although the crowning violence of the great Enemy of

The XVIII. Day. Evening. Prayer. 20 Wilt thou have any thing to do with the stool of wickedness : which imagineth mischief as a law?

Luke xxiii. 14. 23. Acts ix. 4, 5. 21 They gather them together against the soul of the righteous : and condemn the innocent blood.

22 But the Lord is my refuge : and my God is the strength of my confidence.

Rev. xi. 18. 23 He shall recompense them their wickedness, and destroy them in their own malice : yea, the Lord our God shall destroy them.

THE XCV PSALM.

Venite, exultemus.

The XIX. Day. Morning. Prayer. Invitatory Psalm. O COME, let us sing unto the Lord : let us heartily rejoice in the strength of our salvation.

2 Let us come before his presence with thanksgiving : and shew ourselves glad in him with psalms.

Titus ii. 13. 2 Pet. i. 4. 3 For the Lord is a great God : and a great King above all gods.

4 In his hand are all the corners of the earth : and the strength of the hills is his also.

5 The sea is his, and he made it : and his hands prepared the dry land.

6 O come, let us worship and fall down : and kneel before the Lord our Maker.

7 For he is the Lord our God : and we are the people of his pasture, and the sheep of his hand.

Hab. iii. 7-11. iv. 7. Numb. xiv. 1-45. Exod. xvii. 7. 8 To-day if ye will hear his voice, harden not your hearts : as in the provocation, and as in the day of temptation in the wilderness ;

Nunquid adhæret tibi sedes iniquitatis : qui fingis laborem in præcepto? *dolorem*

Captabunt in animam justi : et sanguinem innocentem condemnabunt.

Et factus est mihi Dominus in refugium : et Deus meus in adiutorium *in auxilium* spei meæ.

Et reddet illis iniquitatem ipsorum, *illis Dominus* et in malitia eorum disperdet eos : disperdet illos Dominus Deus noster.

PSALMUS XCIV.

VENITE, exultemus Domino : jubilemus Deo salutari nostro. *Invitatory Psalm Epiphany, Mattins, 2nd Noct.*

Præoccupemus faciem ejus in confessione : et in psalmis jubilemus ei.

Quoniam Deus magnus Dominus : et rex magnus super omnes deos. *omnes deos quoniam non repellit Dominus plebem suam montium ipse conspiciit*

Quia in manu ejus sunt omnes fines terræ : et altitudines montium ipsius sunt.

Quoniam ipsius est mare, et ipse fecit illud : et siccam manus ejus formaverunt. *arida . . . fundaverunt*

Venite adoremus et procidamus et proloremus ante Dominum qui fecit nos : quia ipse est Deus noster : *Dominus Deus*

Et nos populus pascuæ ejus : et oves manus ejus. *populus ejus et oves pascuæ ejus*

Hodie si vocem ejus audieritis : nolite obdurare corda vestra.

Sicut in irritatione : secundum diem *exacerbatione* tentationis in deserto.

PSALM XCV.

For many ages this Psalm has been sung every morning in the whole Western Church, and a portion of it in the Eastern Church, as an Introductory hymn to the other portions of the Psalter; the key to such an usage being found in the second verse, and in the invitation to worship Christ which gives its character to the whole Psalm¹.

In its place in the Psalter it may be regarded as setting forth, in the first half, the Divine Nature of our Lord as "a great God;" His Royalty as "a great King;" His supremacy above all the angels to whom in their majesty and might the name of gods is, in a lower sense, conceded; His glory and power as the Creator of the land and sea (with all that is comprehended in those terms); and as the Sustainer, in His Divine Providence, of all that He has created. In the second half of the Psalm, beginning with

God and man is reserved for a future time, he is still the great Enemy at all times, and the prayer, "Thy Kingdom come," is conjoined with the prayer, "Deliver us from evil,"—the Evil One and all the evil which he causes. Hence the continual prayer of the Church is uttered as in the face of an Enemy whose hatred never ceases, and whose power is being exercised against her year by year and day by day. The One Body, therefore, of whose sufferings the words of this Psalm were once most literally true, and of whom they will be so again, utters them still (even in a time when there is little outward persecution of Christians), because her foe is still what he has been and ever will be, and because all history is one continuous present in the eye of the Lord.

A large portion of this Psalm will bear personal application to the case of individual Christians, who may, in its words, acknowledge before God their sense of His love in the chastisements that are sent to them, and of the comforts with which He alone can refresh the soul in the multitude of its sorrows.

¹ See p. 6 for a note on the use of this as an Invitatory Psalm.

The XIX. Day. 9 When your fathers tempted me :
Morning
Prayer.
1 Cor. x. 9.
Deut. ii. 14.

proved me, and saw my works.
10 Forty years long was I grieved
with this generation, and said : It is a
people that do err in their hearts, for
they have not known my ways ;

Deut. i. 35.

11 Unto whom I swear in my
wrath : that they should not enter
into my rest.

THE XCVI PSALM.

Cantate Domino.

Isa. xlii. 10.
1 Chron. xvi. 23
—33.

O SING unto the Lord a new song :
sing unto the Lord, all the whole
earth.

2 Sing unto the Lord, and praise
his Name : be telling of his salvation
from day to day.

Acts x. 15.
xv. 7, 8.
xxviii. 28.

3 Declare his honour unto the hea-
then : and his wonders unto all people.

4 For the Lord is great, and cannot
worthily be praised : he is more to be
feared than all gods.

Acts xvii. 29, 24.

5 As for all the gods of the heathen,
they are but idols : but it is the Lord
that made the heavens.

Rev. xxi. 16, 11.

6 Glory and worship are before
him : power and honour are in his
sanctuary.

7 Ascribe unto the Lord, O ye kin-
dreds of the people : ascribe unto the
Lord worship and power.

Rev. xxi. 24.

8 Ascribe unto the Lord the honour
due unto his Name : bring presents,
and come into his courts.

9 O worship the Lord in the beauty
of holiness : let the whole earth stand
in awe of him.

Phil. ii. 9—11.

10 Tell it out among the heathen
that the Lord is King : and that it is
he who hath made the round world so
fast that it cannot be moved ; and how
that he shall judge the people righte-
ously.

Ubi tentaverunt me patres vestri :
probaverunt et viderunt opera mea.

Quadraginta annis offensus fui gene- *proximus sui*
rationi illi : et dixi, Semper hi errant
corde.

Et isti non cognoverunt vias meas : *Ipsi vero . . . quibus*
ut juravi in ira mea, Si introibunt in *Juravi*
requiem meam.

PSALMUS XCV.

CANTATE Domino canticum no- *Friday Mattins.*
vum : cantate Domino omnis *Christmas, Cir-*
terra. *cume., Epi-*
phany, Trinity

Cantate Domino, et benedicite No-
mini ejus : annuntiate de die in diem *Sund., Dedic.*
salutare ejus. *Ch., B. V. M.,*
St. Michael,
3rd Noct. bene nuntiate

Annuntiate inter gentes gloriam
ejus : in omnibus populis mirabilia ejus.

Quoniam magnus Dominus, et lau-
dabilis nimis : terribilis est super
omnes deos.

Quoniam omnes dii gentium dæmo-
nia : Dominus autem coelos fecit.

Confessio et pulchritudo in conspectu
ejus : sanctimonia et magnificentia in *sanctitas*
sanctificatione ejus.

Afferte Domino, patriæ gentium,
afferte Domino gloriam et honorem :
afferte Domino gloriam Nomini ejus.

Tollite hostias, et introite in atria *aula*
ejus : adorare Dominum in atrio sancto
ejus.

Commoveatur a facie ejus universa
terra : dicite in gentibus quia Dominus *nationibus Domi-*
regnavit. *nus*

Etenim correxit orbem terræ, qui
non commovebitur : judicabit populos
in æquitate.

in æquitate et
gentes in ira sua

the sixth verse, the glory of Christ is set forth with respect to the relation between Him and mankind : Let us worship Him, for He is not only Creator of the Universe, but He is our Creator, our God, our Divine Shepherd. The latter verses of this second division of the Psalm consist of a warning to the Christian flock of the Good Shepherd drawn from the history of His Jewish flock. "Let us labour, therefore, to enter into that rest, lest any man fall, after the same example of unbelief." [Heb. iv. 11.]

PSALM XCVI.

As our Lord said, "A new commandment I give unto you, That ye love one another : as I have loved you, that ye also love one

another" [John xiii. 34] : so a "new song" commemorates the great change which His Death and Resurrection effected by drawing the heathen into His fold. The glory of the King of kings is no longer to be declared only to His people Israel, but also to the heathen, out of whom He gathers a new Israel when rejected by the unbelieving Jews. The Christian sense of this Psalm, therefore, makes it not only a proclamation of the glory of God as a God infinitely superior to the idols of the heathen, but also a proclamation of the glory of His salvation wrought for all, and an invitation to all to come and sacrifice in His courts, and to worship Him in the beauty of holiness.

This beautiful hymn is therefore a prophetic anticipation of the

The XIX. Day. 11 Let the heavens rejoice, and let the earth be glad : let the sea make a noise, and all that therein is.

Morning Prayer. Rev. v. 13.

12 Let the field be joyful, and all that is in it : then shall all the trees of the wood rejoice before the Lord.

Acts i. 11. xvii. 31. Rev. i. 7. xxii. 20.

13 For he cometh, for he cometh to judge the earth : and with righteousness to judge the world, and the people with his truth.

THE XCVII PSALM.

Dominus regnavit.

THE Lord is King, the earth may be glad thereof : yea, the multitude of the isles may be glad thereof.

Rev. xix. 16. Isa. xli. 11. xlii. 12. li. 5.

2 Clouds and darkness are round about him : righteousness and judgement are the habitation of his seat.

2 Thess. i. 8.

3 There shall go a fire before him : and burn up his enemies on every side.

4 His lightnings gave shine unto the world : the earth saw it, and was afraid.

2 Pet. iii. 12.

5 The hills melted like wax at the presence of the Lord : at the presence of the Lord of the whole earth.

6 The heavens have declared his righteousness : and all the people have seen his glory.

Heb. i. 6.

7 Confounded be all they that worship carved images, and that delight in vain gods : worship him, all ye gods.

8 Sion heard of it, and rejoiced : and the daughters of Judah, were glad, because of thy judgements, O Lord.

Isa. xxiv. 23.

9 For thou, Lord, art higher than all that are in the earth : thou art exalted far above all gods.

Lætentur cœli, et exsultet terra ; commoveatur mare, et plenitudo ejus : gaudebunt campi, et omnia quæ in eis sunt.

Tunc exsultabunt omnia ligna silvarum a facie Domini, quia venit : quoniam venit judicare terram.

Judicabit orbem terræ in æquitate : et populos in veritate sua.

PSALMUS XCVI.

DOMINUS regnavit, exsultet terra : lætentur insulæ multæ.

Friday Mattins. Circumc., Epiphany, Trinity Sund., App. and Evv., B. V. M., St. Michael, 3rd Noct. regnabit

Nubes et caligo in circuitu ejus : justitia et judicium correctio sedis ejus.

Ignis ante ipsum præcedet : et inflammabit in circuitu inimicos ejus.

Alluxerunt fulgura ejus orbi terræ : vidit et commota est terra.

Montes sicut cera fluxerunt a facie Domini : a facie Domini omnis terra.

Domini tremuit omnis

Annuntiaverunt cœli justitiam ejus : et viderunt omnes populi gloriam ejus.

Confundantur omnes qui adorant sculptilia : et qui gloriantur in simulachris suis.

Adorate eum omnes angeli ejus : audivit et lætata est Sion.

Et exsultaverunt filiæ Judæ : propter judicia tua, Domine.

Quoniam tu Dominus altissimus super omnem terram : nimis exaltatus es super omnes deos.

miracle of Pentecost when men of every nation under Heaven heard the wonderful works of God in the Incarnation, Death, and Resurrection of the Lord Jesus, proclaimed to them in their native languages : and of that time when the Apostles learned more distinctly still that it was the purpose of their Master that they should found His Church among the Gentiles as well as the Jews. "God hath highly exalted Him, and given Him a Name which is above every name, that at the Name of Jesus every knee should bow, of things in heaven, and things in earth, and things under the earth : and that every tongue should confess that Jesus Christ is Lord, to the glory of God the Father."

PSALM XCVII.

From the manner in which St. Paul quotes the seventh verse of this Psalm, it must be taken as written altogether to the praise of

our Lord : "When He bringeth in the First-begotten into the world He saith, And let all the angels of God worship Him." It is therefore a hymn to the glory of Christ in respect to His reign in the Kingdom gained by His Incarnation. "He Who stood before the judge, He Who received blows, He Who was scourged, He Who was spit upon, He Who was crowned with thorns, He Who was buffeted, He Who hung upon the cross, He Who, as He hung upon the wood, was mocked, He Who died upon the cross, He Who was pierced with the spear, He Who was buried, He Who arose from the dead : The Lord is King." Such are the forcible words with which St. Augustine begins His exposition of the first verse, and he adds that "the word of God hath been preached, not in the continent alone, but also in those isles which lie in mid-sea ; even these are full of Christians, full of the servants of God ;" by which he appears to refer to the British Isles as

The XIX. Day.
Morning Prayer.
1 Tim. vi. 14.
10 O ye that love the Lord, see that ye hate the thing which is evil : the Lord preserveth the souls of his saints ; he shall deliver them from the hand of the ungodly.

1 Tim. vi. 15, 16.
Isa. lx. 1.
11 There is sprung up a light for the righteous : and joyful gladness for such as are true-hearted.

12 Rejoice in the Lord, ye righteous : and give thanks for a remembrance of his holiness.

THE XCVIII PSALM.

*Cantate Domino.**Evening Prayer.*

OSING unto the Lord a new song : for he hath done marvellous things.

Rev. xv. 2.
Isa. lii. 10.
lix. 16.
2 With his own right hand, and with his holy arm : hath he gotten himself the victory.

Luke ii. 28—30.
iii. 6.
3 The Lord declared his salvation : his righteousness hath he openly shewed in the sight of the heathen.

Isa. lx. 3, 9.
4 He hath remembered his mercy and truth toward the house of Israel : and all the ends of the world have seen the salvation of our God.

5 Shew your selves joyful unto the Lord, all ye lands. : sing, rejoice, and give thanks.

Rev. v. 8, 9.
xiv. 2.
6 Praise the Lord upon the harp : sing to the harp with a psalm of thanksgiving.

7 With trumpets also, and shawms : O shew your selves joyful before the Lord the King.

Rev. v. 13.
8 Let the sea make a noise, and all that therein is : the round world, and they that dwell therein.

Isa. lv. 12.
9 Let the floods clap their hands, and let the hills be joyful together before the Lord : for he is come to judge the earth.

10 With righteousness shall he judge the world : and the people with equity.

Qui diligitis Dominum, odite malum : custodit Dominus animas sanctorum suorum, de manu peccatoris liberabit eos. servorum

Lux orta est justo : et rectis corde lætitia.

Lætamini justi in Domino : et confitemini memoriæ sanctificationis ejus. sanctitatis

PSALMUS XCVII.

CANTATE Domino canticum novum : quia mirabilia fecit. Sat. Mattins. Christmas, Circumc., Trinity Sund., B. V. M., 3rd Noct. fecit Dominus

Salvavit sibi dextera ejus : et brachium sanctum ejus.

Notum fecit Dominus salutare suum : in conspectu gentium revelavit justitiam suam.

Recordatus est misericordiæ suæ : et veritatis suæ domui Israël. Memoravit . . . suæ Jacob . . . domus

Viderunt omnes termini terræ salutem Dei nostri : jubilate Deo omnis terra ; cantate et exultate et psallite. ines

Psallite Domino in cithara, in cithara et voce psalmi : in tubis ductilibus, et voce tubæ cornæ. Deo nostro

Jubilate in conspectu Regis Domini : moveatur mare et plenitudo ejus : orbis terrarum et qui habitant in eo. et universi qui

Flumina plaudent manu, simul montes exsultabunt a conspectu Domini : quoniam venit judicare terram. in id ipsum montes exsultaverunt ante faciem

Judicabit orbem terrarum in justitia : et populos in æquitate.

among those who were known to be glad that the Lord is King. "Let them give glory unto the Lord, and declare His praise in the islands : " "My righteousness is near ; My salvation is gone forth, and Mine arms shall judge the people : the isles shall wait upon Me, and on Mine arm shall they trust."

Thus does all the earth bow down before Jesus as King of kings and Lord of lords, waiting for that time when He shall come in the clouds of heaven to reign in Mount Zion and in Jerusalem, and before His ancients gloriously : once reigning from the Cross

by suffering, for ever from the throne in the majesty of Divine Power.

PSALM XCVIII.

This is a prophetic hymn of the whole Church of God, Jew and Gentile, gathered into the one Christian fold, and singing to the glory of one Lord and King, coming to judge the world with righteousness, power, love, and mercy. The Israel of old, the people gathered from "the ends of the earth," all the created

THE XCIX PSALM.

Dominus regnavit.

The XIX. Day. **T**HE Lord is King, be the people
Evening Prayer.
 never so impatient : he sitteth
 between the cherubims, be the earth
 never so unquiet.

Rev. xi. 17, 18.
 Dan. vii. 14.
 Ezek. i. 5.
 Rev. iv. 6.

2 The Lord is great in Sion : and
 high above all people.

3 They shall give thanks unto thy
 Name : which is great, wonderful, and
 holy.

4 The King's power loveth judge-
 ment; thou hast prepared equity : thou
 hast executed judgement and righte-
 ness in Jacob.

1 Chron. xxviii. 2.
 Isa. lxvi. 1.
 Matt. v. 35.
 5 O magnify the Lord our God :
 and fall down before his footstool, for
 he is holy.

Jer. xv. 1.
 Exod. xxxii. 11.
 1 Sam. vii. 9.
 6 Moses and Aaron among his
 priests, and Samuel among such as
 call upon his Name : these called
 upon the Lord, and he heard them.

Exod. xxxiii. 9-
 11.
 7 He spake unto them out of the
 cloudy pillar : for they kept his testi-
 monies, and the law that he gave them.

8 Thou heardest them, O Lord our
 God : thou forgavest them, O God,
 and punishedst their own inventions.

Isa. vi. 3.
 Rev. iv. 8.
 9 O magnify the Lord our God, and
 worship him upon his holy hill : for the
 Lord our God is holy.

THE C PSALM.

Jubilate Deo.

Mattins Canticle. **O** BE joyful in the Lord, all ye
 lands : serve the Lord with
 gladness, and come before his presence
 with a song.

PSALMUS XCVIII.

DOMINUS regnavit, irascantur
 populi : qui sedes super Cheru-
 bin, moveatur terra.

Sat. Mattins.
 App. and Evv.,
 Dedic. Ch.,
 3rd Noct.
 regnabit

Dominus in Sion magnus : et excel-
 sus super omnes populos.

Confiteantur Nomini tuo magno ;
 quoniam terribile et sanctum est : et
 honor regis judicium diligit.

et terribili quo-
 niam sanctum

Tu parasti directiones : judicium et
 justitiam in Jacob tu fecisti.

parasti aquilitem

Exaltate Dominum Deum nostrum
 et adorate scabellum pedum ejus : quo-
 niam sanctum est.

Moyses et Aaron in sacerdotibus
 ejus : et Samuël inter eos qui invocant
 Nomen ejus.

Invocabunt Dominum, et ipse exau-
 diebat eos : in columna nubis loque-
 batur ad eos.

Custodiebant testimonia ejus : et
 præceptum quod dedit illis.

præcepta quæ
 dederat

Domine, Deus noster, tu exaudiebas
 eos ; Deus tu propitius fuisti eis : et ul-
 ciscens in omnes adinventiones eorum.

et vindicans in
 omnia studia

Exaltate Dominum Deum nostrum,
 et adorate in monte sancto ejus : quo-
 niam sanctus Dominus Deus noster.

PSALMUS XCIX.

JUBILATE Deo omnis terra : ser-
 vite Domino in lætitia.

Sat. Mattins.
 Sund. and Fest.
 Lauds.

Introite in conspectu ejus : in exul-
 tatione.

works of God, are called upon to sing the new song which pro-
 claims the final victory of the King of kings. Such praises for
 the marvellous works of Christ in the salvation of mankind are
 being offered day by day in the Psalms and hymns of the Church,
 and still more in her Eucharistic Sacrifices : but they will be
 offered more purely and fully when the vision of St. John becomes
 a reality : "Every creature which is in Heaven, and on the earth,
 and under the earth, and such as are in the sea, and all that are
 in them heard I saying, Blessing, and honour, and glory, and
 power, be unto Him that sitteth upon the throne, and unto the
 Lamb for ever." Already with voice and with instrumental
 music the Church sings her new song of thanksgiving to her
 King, but hereafter those who have attained a part in His Vic-
 tory over evil will stand upon "as it were a sea of glass mingled
 with fire" surrounded with the dazzling light of a heavenly sun-
 shine, "having the harps of God," and singing "the song of
 Moses the servant of God, and the song of the Lamb, saying,

Great and marvellous are Thy works, Lord God Almighty ; just
 and true are Thy ways, Thou King of saints."

PSALM XCIX.

The Presence of the Lord in His Church is here set forth.
 "He sitteth between the Cherubims" on His throne of mercy, and
 His greatness is manifested in "Zion," the City of God. Before
 the "footstool" of His earthly altar the worship of all is to be
 offered, while His priests and prophets are ministering before
 God and man in the work of intercession : and as His Presence
 was then manifested by a Voice out of the cloudy pillar, so now
 also have we a sure word of promise that where two or three are
 gathered together in His Name, there will He be in the midst of
 them.

It may be observed that the Ter-sanctus of Isaiah and of the
 Revelation is, in some measure, represented in this Psalm. Holy
 is God's Name [v. 3], Holy is He [v. 5], Holy is the Lord our

The XIX. Day.

*Evening**Prayer.*

Deut. xxxii. 6.

Isa. xlii. 7.

Eph. ii. 10.

John x. 14.

1 Pet. ii. 25.

John x. 7. 9.

2 Be ye sure that the Lord he is God; it is he that hath made us, and not we our selves: we are his people, and the sheep of his pasture.

3 O go your way into his gates with thanksgiving, and into his courts with praise: be thankful unto him, and speak good of his Name.

Matt. xxviii. 20.

4 For the Lord is gracious, his mercy is everlasting: and his truth endureth from generation to generation.

THE CI PSALM.

Misericordiam et iudicium.

Royal Accession.

MY song shall be of mercy and judgement: unto thee, O Lord, will I sing.

1 Sam. xviii. 14.

2 O let me have understanding: in the way of godliness.

2 Pet. iii. 12.

Rev. xxii. 20.

3 When wilt thou come unto me: I will walk in my house with a perfect heart.

4 I will take no wicked thing in hand; I hate the sins of unfaithfulness: there shall no such cleave unto me.

5 A froward heart shall depart from me: I will not know a wicked person.

6 Whoso privily slandereth his neighbour: him will I destroy.

7 Whoso hath also a proud look and high stomach: I will not suffer him.

Scitote, quoniam Dominus, ipse est Deus: ipse fecit nos, et non ipsi nos.

Populus ejus et oves pascuæ ejus, *Nos autem pcp.* introite portas ejus in confessione: atria ejus in hymnis; confitemini illi. *hymnis confessionum*

Laudate Nomen ejus; quoniam suavis est Dominus; in æternum misericordia ejus: et usque in generationem *in sæculum neculi* et generationem veritas ejus.

PSALMUS C.

MISERICORDIAM et iudicium: Sat. Mattins. cantabo tibi, Domine.

Psallam et intelligam in via immaculata: quando venies ad me.

Perambulabam in innocentia cordis mei: in medio domus meæ.

Non proponebam ante oculos meos rem injustam: facientes prævaricationes odivi. *rem malam*

Non adhæsit mihi cor pravum: declinantem a me malignum non cognoscebam.

Detrahentem secreto proximo suo: *adversus proximum suum occulte* hunc persequer.

Superbo oculo et insatiabili corde: *hoc simul* cum hoc non edebam.

God [v. 9]: and that (as in Isaiah, Ezekiel, and the Vision of St. John) the Presence of God is associated with mysterious beings called "living creatures," "Seraphim" and "Cherubim." As Isaiah spake of Christ, and beheld His glory in that vision of the Lord, high and lifted up and sitting upon His throne, so also did St. John when he beheld the throne in the midst of the four-and-twenty elders of the Old and New Dispensation. So also in this Psalm we behold the Lord Jesus set before us as the King of glory, the Object of our highest reverence and worship, manifesting His Presence at His footstool.

PSALM C.

This is also a jubilant thanksgiving of the Catholic Church of Christ for the blessing of God's adoption. No longer is the Divine Presence manifested in one land alone, but "all lands" are illuminated by it: no longer is the fold of God opened only to one people, but all the baptized are numbered among the sheep of His pasture; and they are His, not because He has "made" them according to natural Creation, but because they have become adopted children through the supernatural re-creation by which they have been born again.

With great joy, therefore, the Church remembers the words of the Lord, "I am the Good Shepherd, and know My sheep, and am known of Mine." With great joy she calls to mind that He

also said, "By Me if any man enter in, he shall be saved, and go in and out, and find pasture" . . . "there shall be one fold, and one Shepherd." And knowing what "gracious words proceeded out of His mouth" when He was visible among men, those words are to faithful hearts as if they were being continuously spoken, words of mercy and words of truth that never cease to be heard by those who listen for the voice of the Good Shepherd.

This Psalm is, therefore, to be taken as a thanksgiving for the grace given in the Church by the manifestation of Christ's Presence: according to His words of enduring truth, "Lo, I am with you always, even to the end of the world." "The Lord is King," "Be ye sure that the Lord He is God:" even the Lord our Shepherd.

PSALM CI.

Mercy and judgment are the two great characteristics which mark the acts of Christ towards others while He was upon earth, and the two which distinguish His rule in His Kingdom. This Psalm expresses first His righteous purposes while preparing the way of His Kingdom and lifting up the longings of His human heart to the Father; and, secondly, His Voice speaking from the midst of His Mystical Body during the period of its probation and of its waiting for the Second Advent.

Under these two aspects is thus set forth the entire holiness of

The XLX. Day. *Evening Prayer.* 8 Mine eyes look upon such as are faithful in the land : that they may dwell with me.

9 Whoso leadeth a godly life : he shall be my servant.

Rev. xxi. 27. Eph. v. 27. 10 There shall no deceitful person dwell in my house : he that telleth lies shall not tarry in my sight.

Rev. xxii. 12. Matt. iii. 12. 11 I shall soon destroy all the ungodly that are in the land : that I may root out all wicked doers from the city of the Lord.

Oculi mei ad fideles terræ, ut sedent mecum : ambulans in via immaculata, hic mihi ministrabat.

Non habitabit in medio domus meæ qui facit superbiam : qui loquitur iniqua, non direxit in conspectu oculorum meorum.

In matutino interficiebam omnes peccatores terræ : ut disperderem de civitate Domini omnes operantes iniquitatem.

THE CII PSALM.

Domine, exaudi.

The XX. Day. *Morning Prayer.* **H**EAR my prayer, O Lord : and let my crying come unto thee.

Ash-Wednesday Evensong. A Penitential Psalm. 2 Hide not thy face from me in the time of my trouble : incline thine ear unto me when I call ; O hear me, and that right soon.

Job vii. 6. ix. 25. Prov. xvii. 22. Job xxx. 30. 3 For my days are consumed away like smoke : and my bones are burnt up as it were a fire-brand.

Ps. lxix. 20. 4 My heart is smitten down, and withered like grass : so that I forget to eat my bread.

Isa. xxxviii. 13. Job xix. 20. Lam. iv. 8. 5 For the voice of my groaning : my bones will scarce cleave to my flesh.

Isa. xxxviii. 13. Job xxx. 29. 6 I am become like a pelican in the wilderness : and like an owl that is in the desert.

7 I have watched, and am even as it were a sparrow : that sitteth alone upon the house-top.

Matt. xxvii. 39. 41. 8 Mine enemies revile me all the day long : and they that are mad upon me are sworn together against me.

PSALMUS CI.

DOMINE, exaudi orationem meam : *Sat. Mattins.* et clamor meus ad te veniat.

Non avertas faciem tuam a me : in quacunque die tribulor, inclina ad me aurem tuam.

In quacunque die invocavero te : velociter exaudi me.

Quia defecerunt sicut fumus dies mei : et ossa mea sicut cremium aruerunt. *sicut in frizorium confriza sunt*

Percussus sum ut fœnum, et aruit cor meum : quia oblitus sum comedere panem meum. *manducare panem*

A voce gemitus mei : adhesit os meum carni meæ. *adhaserunt ossa mea*

Similis factus sum pellicano solitudinis : factus sum sicut nycticorax in domicilio.

Vigilavi : et factus sum sicut passer solitarius in tecto. *unicus in adificio*

Tota die exprobrabant mihi inimici mei : et qui laudabant me adversum me jurabant.

the Lord Jesus, to Whom alone of all men was given a "perfect heart" in its original nature, and in the obedience of will. To such perfect holiness and righteousness, froward or wilful wickedness, whether of the unfaithful, of the slanderer, of him who has been misled by that pride which gave Satan his first hold on man, of deceitful and lying persons who copy the "father of lies" in their sin, or of any other perverse unholiness, is thoroughly hateful : and our Lord showed His abhorrence of such while He was upon earth ; as He declares respecting His glorified Church that none such shall have a place in the New Jerusalem.

And each particular Christian may take up the words of his holy Lord in the unity of His Mystical Body, so as humbly to use this Psalm respecting his own determination to root out sin from the City of the Lord.

PSALM CII.

In this, the fifth of the Penitential Psalms, the Voice of Christ, as the Representative Penitent, is heard pleading with God for pardon and restoration to His Presence. Though, as St. Augustine says, there are some things which make us fear to say so, there are other things which force us to say so : and a humble reverence influencing all our thoughts on so awful a subject, we may thankfully accept such a meaning as exhibiting the fulness and depth of our Saviour's Sacrifice of Himself for sinners. The same holy Voice is also heard lifting up the supplication of His fainting Church that God will build up the walls of the Heavenly City, and raise it to the glory of a never-ending endurance by filling it with the glory of His eternal Presence. So out of the

<p>The XX. Day. <i>Morning</i> <i>Prayer.</i></p> <p>Ps. xxxviii. 1. Gal. iii. 13.</p> <p>Isa. xxxviii. 12.</p> <p>Isa. lx. 1. Gal. iv. 4.</p> <p>Isa. lxii. 2.</p> <p>Isa. xl. 5. Heb. xii. 22. Isa. liv. 11.</p> <p>Isa. lxii. 4.</p> <p>Isa. lxxv. 17, 18. Eph. ii. 10. John iii. 3. 5.</p> <p>Isa. xl. 9.</p>	<p>9 For I have eaten ashes as it were bread : and mingled my drink with weeping ;</p> <p>10 And that because of thine indignation and wrath : for thou hast taken me up, and cast me down.</p> <p>11 My days are gone like a shadow : and I am withered like grass.</p> <p>12 But thou, O Lord, shalt endure for ever : and thy remembrance throughout all generations.</p> <p>13 Thou shalt arise, and have mercy upon Sion : for it is time that thou have mercy upon her, yea, the time is come.</p> <p>14 And why? thy servants think upon her stones : and it pitieth them to see her in the dust.</p> <p>15 The heathen shall fear thy Name, O Lord : and all the kings of the earth thy Majesty ;</p> <p>16 When the Lord shall build up Sion : and when his glory shall appear ;</p> <p>17 When he turneth him unto the prayer of the poor destitute : and despiseth not their desire.</p> <p>18 This shall be written for those that come after : and the people which shall be born shall praise the Lord.</p> <p>19 For he hath looked down from his sanctuary : out of the heaven did the Lord behold the earth ;</p> <p>20 That he might hear the mournings of such as are in captivity : and deliver the children appointed unto death ;</p> <p>21 That they may declare the Name of the Lord in Sion : and his worship at Jerusalem.</p>	<p>Quia cinerem tanquam panem manducabam : et potum meum cum fletu miscebam. <i>temperabam</i></p> <p>A facie iræ indignationis tuæ : quia iræ et elevans allisisti me.</p> <p>Dies mei sicut umbra declinaverunt : et ego sicut fœnum arui.</p> <p>Tu autem, Domine, in æternum permanes : et memoriale tuum in generatione et generationem. <i>in sæculum sæculi</i></p> <p>Tu exurgens, Domine, misereberis Sion : quia tempus miserendi ejus, quia venit tempus. <i>mis.</i></p> <p>Quoniam placuerunt servis tuis lapides ejus : et terræ ejus miserebuntur. <i>Quia beneplacitum habuerunt servi tui.</i></p> <p>Et timebunt gentes Nomen tuum, Domine : et omnes reges terræ gloriam tuam.</p> <p>Quia ædificavit Dominus Sion : et videbitur in gloria sua. <i>ædificabit . . . in majestate</i></p> <p>Respexit in orationem humilium : et non sprevit precem eorum. <i>pauperum</i></p> <p>Scribantur hæc in generatione altera : et populus qui creabitur laudabit Dominum.</p> <p>Quia prospexit de excelso sancto suo : Dominus de cœlo in terram aspexit ;</p> <p>Ut audiret gemitus compeditorum : ut solveret filios interemptorum. <i>gemitum vinculatorum</i></p> <p>Ut annuntient in Sion Nomen Domini : et laudem ejus in Hierusalem. <i>annuntiatur . . . et laus</i></p>
---	--	--

depth of sorrow for sin Faith looks forward to that blessed time when "God shall wipe away all tears from the eyes of His people; and there shall be no more death, neither sorrow, nor crying, neither shall there be any more pain: for the former things are passed away." [Rev. xxi. 4.]

It is significant of our Lord's great humiliation that His words here are in several places similar to those used by Job: "ye have heard of the patience of Job, and have seen the end of the Lord." [James v. 11.] Thus Job laments, "My days are swifter than a weaver's shuttle, and are spent without hope. . . . My skin is black upon me, and my bones are burned with heat. . . . My bone cleaveth to my skin, and to my flesh. . . . I am a brother to dragons, and a companion to owls. . . . My harp also is turned to mourning, and my organ into the voice of them that weep." Some expressions are also similar to those used by other suffering servants of God; as of Hezekiah when he said, "I reckoned till morning, that, as a lion, so will He break all my bones; from day even to night, so wilt Thou make an end of me. Like a crane

or a swallow, so did I chatter: I did mourn as a dove: mine eyes fail with looking upward: O Lord, I am oppressed, undertake for me." Or as Jeremiah in his Lamentations respecting Israel, "Their visage is blacker than a coal: they are not known in the streets: their skin cleaveth to their bones; it is withered, it is become like a stick." And thus it seems to be intimated that "in all our afflictions He was afflicted," and that when He bore our sins in His own Body on the Cross, He bore all the miseries also that sins bring with them condensed into one scorching ray of woe upon His Person¹.

It is out of the midst of such misery that "The Afflicted One" looked forth on the travail of His soul and was satisfied; and though He had but a few hours before predicted of the Temple and of Jerusalem that not one stone should be left upon another, yet He could say, "Thou shalt arise, and have mercy upon Sion

¹ The title of this Psalm is, "A Prayer of the Afflicted, when He is overwhelmed, and poureth out His complaint before the Lord."

The XX. Day.
Morning
Prayer.

22 When the people are gathered together : and the kingdoms also, to serve the Lord.

23 He brought down my strength in my journey : and shortened my days.

Isa. xxxviii. 10.

24 But I said, O my God, take me not away in the midst of mine age : as for thy years, they endure throughout all generations.

Heb. i. 10.
1 Pet. iii. 5.

25 Thou, Lord, in the beginning hast laid the foundation of the earth : and the heavens are the work of thy hands.

Heb. i. 11, 12.
1 Pet. iii. 10.

26 They shall perish, but thou shalt endure : they all shall wax old as doth a garment ;

Heb. i. 13.
Isa. xxxiv. 4.
Mal. iii. 6.

27 And as a vesture shalt thou change them, and they shall be changed : but thou art the same, and thy years shall not fail.

Isa. lx. 19--22.
Iiv. 13.

28 The children of thy servants shall continue : and their seed shall stand fast in thy sight.

THE CIII PSALM.

Benedic, anima mea.

Luke i. 46.
Eph. i. 3.

PRAISE the Lord, O my soul : and all that is within me praise his holy Name.

2 Praise the Lord, O my soul : and forget not all his benefits ;

3 Who forgiveth all thy sin : and healeth all thine infirmities ;

Job xxxiii. 18.
Lam. iii. 22.

4 Who saveth thy life from destruction : and crowneth thee with mercy and lovingkindness ;

In conveniendo populos in unum :
et reges ut serviant Domino.

Respondit ei in via virtutis suæ :
paucitatem dierum meorum nuntia mihi.

Ne revoces me in dimidio dierum meorum : in generatione et generationem anni tui. *in sæculum sæculi*

Initio tu, Domine, terram fundasti :
et opera manuum tuarum sunt cæli.

Ipsi peribunt, tu autem permanes :
et omnes sicut vestimentum veterascent.

Et sicut opertorium mutabis eos, et mutabuntur : tu autem idem ipse es, et anni tui non deficient.

Filii servorum tuorum habitabunt :
et semen eorum in sæculum dirigitur. *sæculi*

PSALMUS CII.

BENEDIC, anima mea, Domino : *Sat. Mattins. St. Michael, 3rd Noct. All Saints, 1st Noct. interiora mea*
et omnia quæ intra me sunt,
Nomini sancto ejus.

Benedic, anima mea, Domini : et noli oblivisci omnes retributiones ejus.

Qui propitiatur omnibus iniquitatibus tuis : qui sanat omnes infirmitates tuas. *propitius filii languores*

Qui redimit de interitu vitam tuam : *vitam tuam qui satiat in bonis desiderium tuum qui coronat te in misericordione et misericordia : renov.*
quia coronat te in misericordia et misericordionibus.

... When the Lord shall build up Sion," for He knew that the fulness of time had come, and that though the earthly Zion was about to become a desolation, the City of God was to be built up anew, a spiritual house, not made with hands, eternal in the heavens.

To the edification of the spiritual Zion the rest of the Psalm looks ; seeming to say with the prophet, "O Thou afflicted, tossed with tempest, and not comforted, behold, I will lay Thy stones with fair colours, and lay Thy foundations with sapphires. And I will make Thy windows of agates, and Thy gates of carbuncles, and all Thy borders of pleasant stones. And all Thy children shall be taught of the Lord ; and great shall be the peace of Thy children. In righteousness shalt Thou be established." "Thy sun shall no more go down, neither shall Thy moon withdraw itself ; for the Lord shall be Thine everlasting Light, and the days of Thy mourning shall be ended."

So Christ looked forward from His throne of suffering and vicarious penitence to His throne of dominion and glory. So the Church, His Mystical Body, looks forward from the time of

her militant waiting, her contest with sin, her persecution at the hands of Christ's enemies, to the time when the Lord shall create all things new. So the penitent soul, abased before the Judge of all, may look forward too ; and making its prayer "the prayer of the Poor destitute," receive of the riches which His poverty gained for sinners in an Absolution on earth that will be ratified in that Day when the redeemed and pardoned shall "stand fast," upheld by the Cross of their afflicted and glorified Saviour.

PSALM CIII.

The Evangelical key-note to this Psalm was given by St. Paul when he wrote, "Blessed be the God and Father of our Lord Jesus Christ, Who hath blessed us with all spiritual blessings in heavenly places, in Christ."

In its Liturgical use it is to be regarded as the thanksgiving of the Church for the redeeming work of Christ : a thanksgiving offered up indeed on behalf of the whole body of human nature, for every individual member of which that ever lived, or ever will live, Christ died. For the Church is the true "anima mundi ;" and,

The XX. Day.
Morning
Prayer.
Zech. ix. 17.
Isa. xl. 11, 31.
2 Tim. ii. 26.

5 Who satisfieth thy mouth with good things : making thee young and lusty as an eagle.

6 The Lord executeth righteousness and judgement : for all them that are oppressed with wrong.

Exod. xxxiv. 6, 7. 7 He shewed his ways unto Moses : his works unto the children of Israel.

8 The Lord is full of compassion and mercy : long-suffering, and of great goodness.

9 He will not alway be chiding : neither keepeth he his anger for ever.

10 He hath not dealt with us after our sins : nor rewarded us according to our wickednesses.

Isa. i. 18.

11 For look how high the heaven is in comparison of the earth : so great is his mercy also toward them that fear him.

Eph. iii. 18.

12 Look how wide also the east is from the west : so far hath he set our sins from us.

John xx. 17.

13 Yea, like as a father pitieth his own children : even so is the Lord merciful unto them that fear him.

Gen. iii. 19.

14 For he knoweth whereof we are made : he remembereth that we are but dust.

Isa. xl. 6-8.

15 The days of man are but as grass : for he flourisheth as a flower of the field.

16 For as soon as the wind goeth over it, it is gone : and the place thereof shall know it no more.

17 But the merciful goodness of the Lord endureth for ever and ever upon them that fear him : and his righteousness upon children's children ;

18 Even upon such as keep his covenant : and think upon his commandments to do them.

Qui replet in bonis desiderium tuum : renovabitur ut aquilæ juvenus tua.

Faciens misericordias Dominus : et judicium omnibus injuriam patientibus.

Notas fecit vias suas Moysi : filiis Israël voluntates suas.

Miserator et misericors Dominus : *patiens et* longanimis et multum misericors.

Non in perpetuum irascetur : neque *in finem irascitur* in æternum comminabitur. *indignabitur*

Non secundum peccata nostra fecit nobis : neque secundum iniquitates nostras retribuit nobis.

Quoniam secundum altitudinem cœli a terra : corroboravit misericordiam *confirmavit Domi-* suam super timentes se. *nus*

Quantum distat ortus ab occidente : *oriens . . . elongavit* longe fecit a nobis iniquitates nostras.

Quomodo miseretur pater filiorum, *Sicut* misertus est Dominus timentibus se : quoniam ipse cognovit figmentum nostrum. *quia ipse scit*

Recordatus est quoniam pulvis *Memento Domine* sumus : homo sicut fenum dies ejus ; *quod pulvis* tanquam flos agri sic effloreat. *ita floriet*

Quoniam spiritus pertransibit in illo, et non subsistet : et non cognoscet amplius locum suum. *pertransiit . . . et non erit*

Misericordia autem Domini ab æterno : et usque in æternum super timentes eum. *a sæculo et usque in sæculum sæculi*

Et justitia illius in filios filiorum : his qui servant testamentum ejus ; *custodientibus*

Et memores sunt mandatorum ipsius : ad faciendum ea. *Et memoria retinentibus mandata ejus ut faciant ea*

although the world without, and even the dumb creation, praises God in a certain sense by the fulfilment of its duty and vocation, it is within the Church alone that mankind can appreciate the blessings of Redemption, and praise the Lord for them.

The Psalm contemplates mankind, then, as a whole, and in its fallen condition, and looks forward to that work whose effects reached back to the age of the Psalmist and to all previous times, the work by which the Saviour of all brought about the forgiveness of all. The "sin" is thus not any particular sins of one person, but the aggregate sin of mankind, there being no sin for which the blood of Christ is not a sufficient sacrifice and Atonement. The "infirmities" are also those which came upon mankind through sin ; all that long train of physical weaknesses and

degenerations which culminate in death : and all those spiritual weaknesses which the grace of God only can prevent from ending in spiritual destruction. Thus Christ procured a modification of the sentence, "Thou shalt surely die," by redeeming the life of human nature from that incapacity for immortality which was the consequence of the Fall ; and restoring it to the vigour of its first state, making it "young and lusty as an eagle."

This gives the key to the interpretation of the whole Psalm. Man deserved the loss of eternal life and of the Vision of God, but the Lord was full of compassion and mercy, and provided a means of pardon and restoration. Man alienated himself from the family of God, yet He pitieth men as His children still, and remembers that they were created with a power of falling from

The XX. Day.
Morning
Prayer.
John i. 1.
Rev. v. 12.
xix. 11—16.
xxii. 1.
Dan. vii. 10.
Heb. i. 14.
Eph. iii. 10.

19 The Lord hath prepared his seat
in heaven : and his kingdom ruleth
over all.

20 O praise the Lord, ye Angels of
his, ye that excel in strength : ye that
fulfil his commandment, and hearken
unto the voice of his words.

Rev. iv. 8—11.

21 O praise the Lord, all ye his
hosts : ye servants of his that do his
pleasure.

Col. i. 16.

22 O speak good of the Lord, all
ye works of his, in all places of his
dominion : praise thou the Lord, O
my soul.

THE CIV PSALM.

Benedic, anima mea.

Evening
Prayer.
Whitsunday,
Evensong.
Job xl. 10.
Isa. vi. 8.

PRAISE the Lord, O my soul : O
Lord my God, thou art become
exceeding glorious ; thou art clothed
with majesty and honour.

Exod. iii. 2.
1 Tim. vi. 16.
1 John i. 5.
Rev. i. 12—16.
xxi. 23.

2 Thou deckest thy self with light
as it were with a garment : and spread-
est out the heavens like a curtain.

3 Who layeth the beams of his
chambers in the waters : and maketh
the clouds his chariot, and walketh
upon the wings of the wind.

Heb. i. 7.

4 He maketh his angels spirits :
and his ministers a flaming fire.

5 He laid the foundations of the
earth : that it never should move at
any time.

2 Pet. iii. 5.
Job xxxviii. 9.

6 Thou coveredst it with the deep
like as with a garment : the waters
stand in the hills.

Gen. i. 9.

7 At thy rebuke they flee : at the
voice of thy thunder they are afraid.

8 They go up as high as the hills,
and down to the valleys beneath : even
unto the place which thou hast ap-
pointed for them.

Dominus in cœlo paravit sedem
suam : et regnum ipsius omnibus
dominabitur.

Benedicite Domino, omnes angeli
ejus : potentes virtute, facientes ver-
bum illius, ad audiendam vocem ser-
monum ejus.

Benedicite Domino, omnes virtutes
ejus : ministri ejus qui facitis volunta-
tem ejus.

Benedicite Domino, omnia opera
ejus : in omni loco dominationis ejus ;
benedic, anima mea, Domino.

PSALMUS CIII.

BENEDIC, anima mea, Domino : Saturday, Whit-
Domine, Deus meus, magnifica- suntide Mattins.
tus es yehementer.

Confessionem et decorem induisti :
amictus lumine sicut vestimento.

Extendens cœlum sicut pellem : qui
tegis aquis superiora ejus.

Qui ponis nubem ascensum tuum : *Qui ponit, &c.*
qui ambulat super pennas ventorum.

Qui facis angelos tuos spiritus : et
ministros tuos ignem urentem.

Qui fundasti terram super stabilita-
tem suam : non inclinabitur in sæcu-
lum sæculi.

Abyssus, sicut vestimentum, amictus *pallium*
ejus : super montes stabunt aquæ.

Ab increpatione tua fugient : a voce
tonitru tui formidabunt.

Ascendunt montes ; et descendunt
campi : in locum quem fundasti eis.

their first estate, and of returning to the dust from which they
were taken. In His "merciful goodness," therefore, the Son of
God comes down from Heaven to become Man Himself, that the
righteousness of God may be extended upon "children's children"
if they are in the new covenant founded on the Incarnation.

The last verses of the Psalm express the unity of the Church in
Heaven with the Church on earth through the work of Christ.
"Ye are come unto mount Sion, and unto the City of the living
God, the heavenly Jerusalem, and to an innumerable company of
angels : to the general assembly and Church of the Firstborn,
which are written in Heaven." [Heb. xii. 22.]

PSALM CIV.

This is a hymn of praise to the Creator of all things visible and
invisible : and it looks beyond the first Creation to that time of

which Isaiah was inspired to prophesy in the words of God
Himself, "Behold, I create new heavens and a new earth : and
the former shall not be remembered, nor come into mind ; but be
ye glad and rejoice in that which I create : for, behold, I
create Jerusalem a rejoicing, and her people a joy." [Isa. lxxv.
17.] For this reason the Church has appointed this Psalm for
Whitsunday, as being one the mystical sense of which glorifies
God the Holy Ghost, the "Giver of life," in the spiritual creation :
and formerly this sense was brought out even more conspicuously
by the use of the Psalm throughout the Octave as well as on
Whitsunday itself.

Whatever is recorded in Holy Scripture respecting the natural
Creation is set down from information given by the Creator Him-
self : and in whatever language, whether that of history, prophecy,
or poetry, such information is given, the absolute Truthfulness of

The XX. Day.
Evening
Prayer.
Job xxxviii. 11.
Gen. i. 6, 7.
Job xxxviii. 16.

9 Thou hast set them their bounds which they shall not pass : neither turn again to cover the earth.

10 He sendeth the springs into the rivers : which run among the hills.

11 All beasts of the field drink thereof : and the wild asses quench their thirst.

12 Beside them shall the fowls of the air have their habitation : and sing among the branches.

Job xxxviii. 26.
Deut. xi. 14.
Matt. v. 45.

13 He watereth the hills from above : the earth is filled with the fruit of thy works.

14 He bringeth forth grass for the cattle : and green herb for the service of men ;

Gen. xiv. 18.
Matt. xxvi. 27.
Ps. xlv. 7.
Rev. vi. 6.

15 That he may bring food out of the earth, and wine that maketh glad the heart of man : and oil to make him a cheerful countenance, and bread to strengthen man's heart.

Rev. xxii. 2.
Numb. xxiv. 6.

16 The trees of the Lord also are full of sap : even the cedars of Libanus which he hath planted.

17 Wherein the birds make their nests : and the fir-trees are a dwelling for the stork.

18 The high hills are a refuge for the wild goats : and so are the stony rocks for the conies.

19 He appointed the moon for certain seasons : and the sun knoweth his going down.

20 Thou makest darkness that it may be night : wherein all the beasts of the forest do move.

21 The lions roaring after their prey : do seek their meat from God.

22 The sun ariseth, and they get them away together : and lay them down in their dens.

23 Man goeth forth to his work, and to his labour : until the evening.

Terminum posuisti, quem non transgredientur : neque convertentur operire terram.

Qui emittis fontes in convallibus : *emittet* inter medium montium pertransibunt aquæ.

Potabunt omnes bestię agri : *bestię silvarum* tabunt onagri in siti sua.

Super ea volucres cœli habitabunt : de medio petrarum dabunt voces.

Rigans montes de superioribus suis : de fructu operum tuorum satiabitur terra.

Producens fœnum jumentis : et herbam servituti hominum.

Ut educas panem de terra : et vinum *educat* lætificet cor hominis.

Ut exhilet faciem in oleo : et panis cor hominis confirmet.

Saturabuntur ligna campi, et cedri *omnia ligna silvarum* Libani quas plantavit : illic passeret plantasti nidificabunt.

Herodii domus dux est eorum : *Fulice domus* montes excelsi cervis ; petra refugium herinacis.

Fecit lanam in tempora : sol cognovit occasum suam.

Posuisti tenebras, et facta est nox : in ipsa pertransibunt omnes bestię silvæ.

Catuli leonum rugientes, ut rapiant : et quærant a Deo escam sibi.

Ortus est sol, et congregati sunt : et in cubilibus suis collocabuntur.

Exibit homo ad opus suum : et ad operationem suam usque ad vesperam.

God makes it impossible that the substance of it should be inconsistent with fact. In this Psalm we are, therefore, provided with a Divine Creed respecting the work of the Creator. The words are given us by God Himself that we may use them in His praise. Although perfectly consistent with the Mosaic narrative, the Psalm has sufficiently independent characteristics to make it improbable that it was in any way founded on that narrative, and we may consider it more justly as a new revelation, in which the Divine Wisdom teaches man to speak of his Creator's work out of the depth of a knowledge that cannot err ; and especially to glorify

that continuous act of Creation by which the universe is preserved in order, beauty, and usefulness.

Such a Christian strain is a constant witness against that kind of unbelief which denies the overruling hand of God, and believes a monstrous fable of independent and self-originate action in the operations of nature. It is the voice of the Church reading God's glory from age to age in every page of the book of Nature, and saying, "Thou art worthy, O Lord, to receive glory, and honour, and power ; for Thou hast created all things, and for Thy pleasure they are and were created." [Rev. iv. 11.]

The XX. Day
Evening
Prayer.

24 O Lord, how manifold are thy works : in wisdom hast thou made them all ; the earth is full of thy riches.

25 So is the great and wide sea also : wherein are things creeping innumerable, both small and great beasts.

Job xl. 20.

26 There go the ships, and there is that Leviathan : whom thou hast made to take his pastime therein.

27 These wait all upon thee : that thou mayest give them meat in due season.

28 When thou givest it them they gather it : and when thou openest thy hand they are filled with good.

Job xxxiv. 14, 15.

29 When thou hidest thy face they are troubled : when thou takest away their breath they die, and are turned again to their dust.

Ezek. xxxvii. 9, 10.

30 When thou lettest thy breath go forth they shall be made : and thou shalt renew the face of the earth.

Isa. lxv. 17—19.

31 The glorious Majesty of the Lord shall endure for ever : the Lord shall rejoice in his works.

32 The earth shall tremble at the look of him : if he do but touch the hills, they shall smoke.

Isa. lxvi. 22, 23.

33 I will sing unto the Lord as long as I live : I will praise my God while I have my being.

34 And so shall my words please him : my joy shall be in the Lord.

Rev. xix. 1—7.

35 As for sinners they shall be consumed out of the earth, and the ungodly shall come to an end : praise thou the Lord, O my soul, praise the Lord.

THE CV PSALM.

Confitemini Domino.

The XXI. Day.
Morning
Prayer.
1 Chron. xvi. 8—22.
Cf. Acts viii. 2—45.

O GIVE thanks unto the Lord, and call upon his Name : tell the people what things he hath done.

Quam magnificata sunt opera tua, Domine: omnia in sapientia fecisti; impleta est terra possessione tua.

creatura tua

Hoc mare magnum et spatiosum manibus: illic reptilia quorum non est numerus.

spatiosum illic reptilia

Animalia pusilla cum magnis: illic naves pertransibunt.

Draco iste quem formasti ad illudendum ei: omnia a te exspectant, ut des illis escam in tempore.

exp Domine

Dante te illis, colligent: aperiente te manum tuam, omnia implebuntur bonitate.

replebuntur ubertate

Avertente autem te faciem, turbabuntur: auferes spiritum eorum et deficient, et in pulverem suum revertentur.

Emitte spiritum tuum et creabuntur: et renovabis faciem terræ.

Sit gloria Domini in sæculum: lætabitur Dominus in operibus suis.

sæc. sæculi

Qui respicit terram, et facit eam tremere: qui tangit montes et fumigant.

fumigant

Cantabo Domino in vita mea: psallam Deo meo quamdiu sum.

Jucundum sit ei eloquium meum: ego vero delectabor in Domino.

Suaris sit ei laudatio mea

Deficiant peccatores a terra, et iniqui ita ut non sint: benedic, anima mea, Domino.

PSALMUS CIV.

CONFITEMINI Domino et invocate Nomen ejus: annuntiate inter gentes opera ejus.

Sat. Mattins.

It has already been remarked that this Psalm has a further meaning, viz., a typical reference to the spiritual world of New Creation. The manner in which this mystical sense may be drawn out is almost self-evident to any mind accustomed to use the Psalms from day to day in the services of the Church. When we sing, "Thou deckest Thyself with light as with a garment," we cannot but think of those frequent allusions to light in connexion with God's Presence which culminate in the Apostolic saying, "God is Light;" the words of our Lord, "I am the Light of the world;" and the Vision of the New Creation in the Apocalypse, "The City had no need of the sun, neither of the moon, to shine in it: for the glory of God did lighten it, and the

Lamb is the light thereof." The Creator laying "the beams of His chambers in the waters" brings up thoughts of those waters of Baptism on which the Holy Spirit founds the work of New Creation in the Church of God. The many allusions to water will lead the mind to dwell on the streams of grace which flow like a "pure river of water of life, clear as crystal, proceeding out of the throne of God and of the Lamb." Man "going forth to his work and to his labour until the evening" represents the whole period of that dispensation which will end in "the rest that remaineth for the people of God;" and the regeneration and glorious resurrection of mankind and nature is clearly indicated by the renewal of the earth under the operation of God's Spirit

The XXI. Day.
Morning
Prayer.

2 O let your songs be of him, and praise him : and let your talking be of all his wondrous works.

3 Rejoice in his holy Name : let the heart of them rejoice that seek the Lord.

4 Seek the Lord and his strength : seek his face evermore.

5 Remember the marvellous works that he hath done : his wonders, and the judgements of his mouth ;

6 O ye seed of Abraham his servant : ye children of Jacob his chosen.

7 He is the Lord our God : his judgements are in all the world.

Luke i. 72, 73.

8 He hath been alway mindful of his covenant and promise : that he made to a thousand generations ;

Gen. xvii. 2—7.
xxvi. 3.

9 Even the covenant that he made with Abraham : and the oath that he swore unto Isaac ;

Gen. xxviii. 14.
xxxv. 11, 12.

10 And appointed the same unto Jacob for a law : and to Israel for an everlasting testament ;

11 Saying, Unto thee will I give the land of Canaan : the lot of your inheritance.

Gen. xii. 1—20.
xiii. 12.
xx. 3—7.
xxvi. 11.
Luke xii. 32.

12 When there were yet but a few of them : and they strangers in the land ;

13 What time as they went from one nation to another : from one kingdom to another people ;

14 He suffered no man to do them wrong : but reprovèd even kings for their sakes ;

Rev. vii. 3.

15 Touch not mine Anointed : and do my prophets no harm.

Gen. xli. 54.

16 Moreover, he called for a dearth upon the land : and destroyed all the provision of bread.

Gen. xxxvii. 28.
36.

17 But he had sent a man before them : even Joseph, who was sold to be a bondservant ;

Cantate ei et psallite ei : narrate omnia mirabilia ejus ; laudamini in Nomine sancto ejus.

Lætetur cor quærentium Dominum ; quærite Dominum et confirmamini : quærite faciem ejus semper.

Mementote mirabilium ejus quæ fecit : prodigia ejus et judicia oris ejus.

Semen Abraham servi ejus : filii Jacob electi ejus.

Ipse Dominus Deus noster : in universa terra judicia ejus.

Mémor fuit in sæculum testamenti sui : verbi, quod mandavit in mille generationes.

Quod disposuit ad Abraham : et juramenti sui ad Isaac.

Et statuit illud Jacob in præceptum : et Israël in testamentum æternum.

Dicens, Tibi dabò terram Chanaan : funiculum hæreditatis vestræ.

Cum essent numero brevi : paucissimi, et incolæ ejus.

Et pertransierunt de gente in gentem : et de regno ad populum alterum.

Non reliquit hominem nocere eis : permisit et corripuit pro eis reges.

Nolite tangere christos meos : et in prophetis meis nolite malignari.

Et vocavit famem super terram : et omne firmamentum panis contrivit.

Misit ante eos virum : in servum venundatus est Joseph.

again going forth as at the first Creation. Thus we sing to the glory of the Lord, not only respecting the visible Creation, but also respecting that of which "He that sat upon the throne said, Behold, I make all things new."

PSALM CV.

This and the following Psalm were written, prophetically or historically, with reference to the Captivity in Babylon. The one rehearses, in the form of a didactic hymn, the great goodness which God had ever shown to His people, and His faithfulness in keeping the covenant which He had made with their forefathers, Abraham, Isaac, and Jacob, and with themselves, as a nation, in

the time of Moses. The other recounts the history of the unfaithfulness which Israel had so continually shown towards God, and the sins for which He had suffered them to be carried into captivity.

The first fifteen verses of this Psalm form part of that of which it is said, "On that day David delivered first this Psalm to thank the Lord into the hand of Asaph and his brethren," and the first and the last two verses of the 106th Psalm are identical with the last three of the one so spoken of. [1 Chron. xvi. 1—36.] Both the 105th and the 106th Psalms seem to be also associated with the 104th by the sequence of the subjects and by the Hallelujah, or Praise ye the Lord, which concludes all three and

<p>The XXI. Day. Morning Prayer.</p>	<p>18 Whose feet they hurt in the stocks : the iron entered into his soul ;</p>	<p>Humiliaverunt in compedibus pedes ejus : ferrum pertransiit animam ejus, donec veniret verbum ejus.</p>
	<p>19 Until the time came that his cause was known : the word of the Lord tried him.</p>	<p>Eloquium Domini inflammavit eum : misit rex et solvit eum ; princeps populorum et dimisit eum.</p>
<p>Gen. xli. 14.</p>	<p>20 The king sent, and delivered him : the prince of the people let him go free.</p>	
<p>Gen. xli. 40, 48.</p>	<p>21 He made him lord also of his house : and ruler of all his substance ;</p>	<p>Constituit eum dominum domus suæ : et principem omnis possessionis suæ.</p>
	<p>22 That he might inform his princes after his will : and teach his senators wisdom.</p>	<p>Ut erudiret principes ejus sicut semetipsum : et senes ejus prudentiam doceret.</p>
<p>Gen. xlii. 6. Deut. x. 22.</p>	<p>23 Israel also came into Egypt : and Jacob was a stranger in the land of Ham.</p>	<p>Et intravit Israël in Ægyptum : et Jacob accola fuit in terra Cham. <i>habitarit</i></p>
<p>Exod. i. 7, 12.</p>	<p>24 And he increased his people exceedingly : and made them stronger than their enemies ;</p>	<p>Et auxit populum suum vehementer : nimis et firmavit eum super inimicos ejus.</p>
	<p>25 Whose heart turned so, that they hated his people : and dealt untruly with his servants.</p>	<p>Convertit cor eorum ut odirent populum ejus : et dolum facerent in servos ejus.</p>
<p>Exod. iii. 10. iv. 14.</p>	<p>26 Then sent he Moses his servant : and Aaron whom he had chosen.</p>	<p>Misit Moysen servum suum : Aaron quem elegit ipsum.</p>
	<p>27 And these shewed his tokens among them : and wonders in the land of Ham.</p>	<p>Posuit in eis verba signorum suorum : et prodigiorum in terra Cham. <i>Chanaan</i></p>
<p>Exod. x. 22. Cf. Gen. i. 3. Rev. viii. 12. xvi. 10.</p>	<p>28 He sent darkness, and it was dark : and they were not obedient unto his word.</p>	<p>Misit tenebras et obscuravit : et non exacerbavit sermones suos. <i>quia exacerbaverunt . . . ejus</i></p>
<p>Exod. vii. 20, 21. Rev. viii. 8. xvi. 3-7.</p>	<p>29 He turned their waters into blood : and slew their fish.</p>	<p>Convertit aquas eorum in sanguinem : et occidit pisces eorum.</p>
<p>Exod. viii. 6. Rev. xvi. 13, 14.</p>	<p>30 Their land brought forth frogs : yea, even in their kings' chambers.</p>	<p>Et dedit terra eorum ranas : in penetralibus regum ipsorum. <i>Misit . . . in cubilibus</i></p>
<p>Exod. viii. 24, 17.</p>	<p>31 He spake the word, and there came all manner of flies : and lice in all their quarters.</p>	<p>Dixit et venit cynomyia et ciniphes : in omnibus finibus eorum.</p>
<p>Exod. ix. 23, 24. Rev. viii. 7. xvi. 8, 21.</p>	<p>32 He gave them hail-stones for rain : and flames of fire in their land.</p>	<p>Posuit pluvias eorum grandinem : ignem comburentem in terra ipsorum.</p>
<p>Exod. ix. 25.</p>	<p>33 He smote their vines also and fig-trees : and destroyed the trees that were in their coasts.</p>	<p>Et percussit vineas eorum et ficulneas eorum : et contrivit lignum finium eorum. <i>omne lignum</i></p>

begins the two former¹, and appears, for the first time, in this series of Psalms.

As the Old Testament is now as much the heritage of the Christian as it was anciently of the Jewish Church, so the history of God's ancient people is part of the history of the one chosen people of God : for there is an essential continuity between the Church of the Old and the Church of the New Dispensation through the Person of our Blessed Lord. In singing this Psalm, therefore, the Church of Christ is (1) celebrating the merciful Providence of God in so preserving the particular nation of the

Jews that from among their number the Saviour should be born : and (2) praising Him also for His continual loving-kindness to those whom Christians must regard as their own spiritual ancestors.

But, in addition to this literal sense in which the Psalm is to be used, it must be remembered that the history of Israel is typical in the highest degree : and that we are, therefore, justified in looking for mystical meanings throughout in any portion of Holy Scripture, and especially the Psalms, in which the events of that history are recounted. Some of these mystical meanings may be particularly noticed. The foundation of the whole Psalm, for example, is the covenant which God made with the patriarchs, "saying, Unto thee will I give the land of Canaan, the lot of

¹ The 78th, 135th, and 136th Psalms are of a similar character to the 105th and 106th, as is also the discourse of St. Stephen.

The XXI. Day.
Morning
Prayer.
Exod. x. 15.
Rev. ix. 3—10.

34 He spake the word, and the grasshoppers came, and caterpillars innumerable : and did eat up all the grass in their land, and devoured the fruit of their ground.

Exod. xii. 29.
Rev. viii. 15.

35 He smote all the first-born in their land : even the chief of all their strength.

Exod. xii. 35, 36.

36 He brought them forth also with silver and gold : there was not one feeble person among their tribes.

37 Egypt was glad at their departing : for they were afraid of them.

Exod. xiii. 21, 22.

38 He spread out a cloud to be a covering : and fire to give light in the night-season.

Exod. xvi. 13, 14.

39 At their desire he brought quails : and he filled them with the bread of heaven.

Exod. xvii. 6.

40 He opened the rock of stone, and the waters flowed out : so that rivers ran in the dry places.

Gen. xv. 14.

41 For why? he remembered his holy promise : and Abraham his servant.

42 And he brought forth his people with joy : and his chosen with gladness ;

Deut. vi. 10, 11.

43 And gave them the lands of the heathen : and they took the labours of the people in possession ;

Deut. vi. 24, 25.

44 That they might keep his statutes : and observe his laws.

THE CVI PSALM.

Confitemini Domino.

Evening
Prayer.
1 Chron. xvi. 44.

O GIVE thanks unto the Lord, for he is gracious : and his mercy endureth for ever.

Dixit et venit locusta et bruchus :
cujus non erat numerus.

Et comedit omne fœnum in terra fœnum in terra eorum et percussit omne, &c.
eorum : et comedit omnem fructum terræ eorum.

Et percussit omne primogenitum in terra eorum : primitias omnis laboris terra Egypti eorum.

Et eduxit eos cum argento et auro :
et non erat in tribubus eorum infirmus.

Lætata est Ægyptus in protectione eorum : quia incubuit timor eorum cecidit super eos.

Expandit nubem in protectionem eorum : et ignem ut luceret eis per noctem.

Petierunt, et venit coturnix : et pane Petierunt carnes et cœli saturavit eos.

Dirupit petram et fluxerunt aquæ :
abierunt in sicco flumina :

Quoniam memor fuit verbi sancti sui : quod habuit ad Abraham puerum quod locutus est ad suum.

Et eduxit populum suum in exultatione : et electos suos in lætitia.

Et dedit illis regiones gentium : et labores populorum possederunt :

Ut custodiant justificationes ejus : et legem ejus exquirant.

PSALMUS CV.

CONFITEMINI Domino, quoniam Sat. Mattins. bonus : quoniam in sæculum misericordia ejus.

your inheritance :” which covenant was made when “there were yet but a few of them : and they strangers in the land.” Such a covenant, also, was made by God with His newly-chosen people, a covenant signified in our Lord’s words, “Fear not, little flock ; for it is your Father’s good pleasure to give you the kingdom.” [Luke xii. 32.] “To him that overcometh will I grant to sit with Me in My throne, even as I also overcame, and am set down with My Father in His throne.” [Rev. iii. 21.] Again, the Touch not Mine Anointed of the Psalm clearly refers, literally, to the Patriarchs and to their descendants ; mystically it is impossible not to see its reference to Christ and to those who are made kings and priests by the unction of the Holy Spirit. In the sending a Man before them, even Joseph, who was sold to be a bond-servant, whose feet they hurt in the stocks, the iron entered into his soul, we cannot fail to see a mystical type of the Man Who took upon Him the form of a servant, Whose feet were fastened to the Cross, Whose heart the iron lance pierced through,

and Whom the King delivered in the Resurrection, making Him Lord also of His house, and Ruler of all His substance, by raising His Human Nature to the throne of Heaven. So also, in the increase of the people of Israel, in their growing stronger than their enemies, in the hatred of them, and the untrue dealing to which they were subjected, it is not difficult to see a typical representation of the first growth of the Church, and of its contest with the heathen world. Lastly, the plagues of Egypt find their parallel in the last plagues of Antichrist predicted in the Apocalypse : and the deliverance of the people from Egypt, their going forth with gladness, is a type of that final rest of the Church when it will have entered upon the many mansions prepared for it by the Father.

PSALM CVI.

The first and the last two verses of this Psalm are to be found, as already mentioned, in the dedication hymn of David : but the

The XXI. Day. <i>Evening</i> <i>Prayer.</i> Eccles. xliiii. 30.	2 Who can express the noble acts of the Lord : or shew forth all his praise?	Quis loquetur potentias Domini : auditas faciet omnes laudes ejus?
	3 Blessed are they that alway keep judgement : and do righteousness.	Beati qui custodiunt judicium et faciunt justitiam : in omni tempore.
Neh. xlii. 14. 22.	4 Remember me, O Lord, according to the favour that thou bearest unto thy people : O visit me with thy salvation.	Memento nostri, Domine, in benedicto populi tui : visita nos in salutari tuo.
Luke x. 23.	5 That I may see the felicity of thy chosen : and rejoice in the gladness of thy people, and give thanks with thine inheritance.	Ad videndum in bonitate electorum tuorum, ad lætandum in lætitia gentis tuæ : ut lauderis cum hæreditate tua.
Dan. ix. 5. Acts viii. 51—53.	6 We have sinned with our fathers : we have done amiss, and dealt wickedly.	Peccavimus cum patribus nostris : injuste egimus, iniquitatem fecimus.
Exod. xiv. 11, 12.	7 Our fathers regarded not thy wonders in Egypt, neither kept they thy great goodness in remembrance : but were disobedient at the sea, even at the Red sea.	Patres nostri in Ægypto non intellexerunt mirabilia tua : non fuerunt memores multitudinis misericordiæ tuæ.
		Et irritaverunt ascendentes in mare : <i>asc. in Rubro mare mare Rubrum.</i>
Exod. ix. 16.	8 Nevertheless, he helped them for his Name's sake : that he might make his power to be known.	Et salvavit eos propter Nomen suum : <i>liberavit</i> ut notam faceret potentiam suam.
Exod. xiv. 21, 22. Rev. xvi. 12.	9 He rebuked the Red sea also, and it was dried up : so he led them through the deep, as through a wilderness.	Et increpuit mare Rubrum, et exsiccatum est : et deduxit eos in abyssis <i>in aquis multis</i> sicut in deserto.
Exod. xiv. 30.	10 And he saved them from the adversary's hand : and delivered them from the hand of the enemy.	Et salvavit eos de manu odientium : <i>liberavit</i> et redemit eos de manu inimici.
Exod. xiv. 28.	11 As for those that troubled them, the waters overwhelmed them : there was not one of them left.	Et operuit aqua tribulantes eos : unus ex eis non remansit.
Exod. xv. 1—21.	12 Then believed they his words : and sang praise unto him.	Et crediderunt verbis ejus : et laudaverunt laudem ejus.
Exod. xvi. 2.	13 But within a while they forgot his works : and would not abide his counsel.	Cito fecerunt, obliti sunt operum ejus : et non sustinuerunt consilium ejus.
Numb. xi. 4.	14 But lust came upon them in the wilderness : and they tempted God in the desert.	Et concupierunt concupiscentiam in deserto : et tentaverunt Deum in inastocitate quoso.
Numb. xi. 31.	15 And he gave them their desire : and sent leanness withal into their soul.	Et dedit eis petitionem ipsorum : et misit saturitatem in animas eorum.
Numb. xvi. 1.	16 They angered Moses also in the tents : and Aaron the saint of the Lord.	Et irritaverunt Moysen in castris : Aaron sanctum Domini.

fourth and sixth verses seem to connect it with the prophets Daniel and Nehemiah. The whole Psalm is a confession of national sins, cast in the form of a penitential hymn : and its tone is that of Daniel's prayer when he knew that the time of the Captivity was drawing to a close, "We have sinned, and have committed iniquity, and have done wickedly, and have rebelled, even by departing from Thy precepts, and from Thy judgments." As the preceding Psalm recounts the noble acts of the Lord with a view to His praise, so

are they recounted, in this one, for the sake of confession on the part of His people : and as, in that, God is glorified by the Christian Church for His mercies to His one people in the days before Christ and in the present dispensation, so this Psalm of confession is offered up on behalf, and in the name, of the same one continuous spiritual fellowship in both periods of its progress towards the unveiled Presence of the Lord, "the felicity of His chosen."

Thus the Church of God is ever being brought out of the mys-

The XXI. Day. Evening Prayer. Numb. xvi. 31— 33.	17 So the earth opened, and swallowed up Dathan : and covered the congregation of Abiram.	Aperta est terra, et deglutivit Dathan : et operuit super congregationem Abiron. <i>synagoga</i>
Numb. xvi. 35.	18 And the fire was kindled in their company : the flame burnt up the ungodly.	Et exarsit ignis in synagoga eorum : flamma combussit peccatores.
Exod. xxxii. 4.	19 They made a calf in Horeb : and worshipped the molten image.	Et fecerunt vitulum in Horeb : et adoraverunt sculptile.
Jer. ii. 11	20 Thus they turned their glory : into the similitude of a calf that eateth hay.	Et mutaverunt gloriam suam : in similitudinem vituli comedentis fœ- <i>manducantis</i> num.
	21 And they forgot God their Saviour : who had done so great things in Egypt ;	Obliti sunt Deum qui salvavit eos : <i>liberavit</i> qui fecit magnalia in Ægypto, mirabilia in terra Cham, terribilia in mari <i>Chanaan</i> Rubro.
	22 Wondrous works in the land of Ham : and fearful things by the Red sea.	
Exod. xxxii. 9— 14.	23 So he said, he would have destroyed them, had not Moses his chosen stood before him in the gap : to turn away his wrathful indignation, lest he should destroy them.	Et dixit ut disperderet eos : si non Moyses electus ejus stetisset in con- fractione in conspectu ejus.
Numb. xiii. 32.	24 Yea, they thought scorn of that pleasant land : and gave no credence unto his word ;	Ut averteret iram ejus, ne disperderet eos : et pro nihilo habuerunt terram desiderabilem.
Numb. xiv. 2.	25 But murmured in their tents : and hearkened not unto the voice of the Lord.	Non crediderunt verbo ejus, et murmuraverunt in tabernaculis suis : non exaudierunt vocem Domini.
Numb. xiv. 28, 29.	26 Then lift he up his hand against them : to overthrow them in the wilderness ;	Et elevavit manum suam super eos : ut prosterneret eos in deserto :
Lev. xxvi. 33.	27 To cast out their seed among the nations : and to scatter them in the lands.	Et ut dejiceret semen eorum in nationibus : et disperderet eos in regionibus.
Numb. xxv. 3.	28 They joined themselves unto Baal-peor : and ate the offerings of the dead.	Et initiati sunt Beëlphégor : et <i>consecrati . . . et manducaverunt</i> comederunt sacrificia mortuorum.
	29 Thus they provoked him to anger with their own inventions : and the plague was great among them.	Et irritaverunt eum in adinven- <i>in studiis suis</i> tionibus suis : et multiplicata est in eis ruina.
Numb. xxv. 7, 8.	30 Then stood up Phinees and prayed : and so the plague ceased.	Et stetit Phinees, et placavit : et <i>et exoravit</i> cessavit quassatio.
Numb. xxv. 11— 13.	31 And that was counted unto him for righteousness : among all posterities for evermore.	Et reputatum est ei in justitiam : in generatione et generationem, usque in <i>in seculum</i> sempiternum.

tical Egypt by the guiding Providence of her Almighty Head, and ever being "delivered from the hand of the Enemy." This was most conspicuous in the early ages when Satan made the heathen persecutors his instruments for the destruction of the Church, and when her continued existence was a continuous miracle of Divine power. Passing through a Red Sea of persecution, the very waters into which she was driven by the Adversary's hand were the means of her preservation, and Heathenism itself was thus overwhelmed by what was intended to have been the destruction of Christianity. It has been generally thought by holy men that

the words, "there was no more sea" [Rev. xxi. 1], are a mystical prophecy of the time when the Adversary's hand will cease to be lifted up for the destruction of the Church, and God will give her final rest and peace.

But "within a while they forgot His works." With the overwhelming of Heathenism and the comparative peace which followed, "lust came upon them in the wilderness," a desire of temporal power, and a general worldliness in which Christians often "forgot His counsel," "My Kingdom is not of this world." In the Eastern and the Western Church its rulers and people alike

<p>The XXI. Day. <i>Evening</i> <i>Prayer.</i> Numb. xx. 12.</p> <p>Numb. xx. 10.</p> <p>Judg. i. 21. 27— 29.</p> <p>Judg. ii. 2.</p> <p>Judg. ii. 12.</p> <p>Lev. xx. 1—5. Cf. Jer. xxii. 35. Numb. xxxvi. 34.</p> <p>Judg. ii. 14.</p> <p>Judg. ii. 16.</p> <p>Lev. xxvi. 42. Ezra ix. 9.</p>	<p>32 They angered him also at the waters of strife : so that he punished Moses for their sakes ;</p> <p>33 Because they provoked his spirit : so that he spake unadvisedly with his lips.</p> <p>34 Neither destroyed they the heathen : as the Lord commanded them ;</p> <p>35 But were mingled among the heathen : and learned their works.</p> <p>36 Inasmuch that they worshipped their idols, which turned to their own decay : yea, they offered their sons and their daughters unto devils ;</p> <p>37 And shed innocent blood, even the blood of their sons and of their daughters : whom they offered unto the idols of Canaan, and the land was defiled with blood.</p> <p>38 Thus were they stained with their own works : and went a whoring with their own inventions.</p> <p>39 Therefore was the wrath of the Lord kindled against his people : inasmuch that he abhorred his own inheritance.</p> <p>40 And he gave them over into the hand of the heathen : and they that hated them were lords over them.</p> <p>41 Their enemies oppressed them : and had them in subjection.</p> <p>42 Many a time did he deliver them : but they rebelled against him with their own inventions, and were brought down in their wickedness.</p> <p>43 Nevertheless, when he saw their adversity : he heard their complaint.</p> <p>44 He thought upon his covenant, and pitied them according unto the multitude of his mercies : yea, he made all those that led them away captive to pity them.</p>	<p>Et irritaverunt eum ad aquas contradictionis : et vexatus est Moyses propter eos ; quia exacerbaverunt spiritum ejus.</p> <p>Et distinxit in labiis suis : non perdiderunt gentes quas dixit Dominus illis.</p> <p>Et commixti sunt inter gentes, et didicerunt opera eorum ; et servierunt sculptilibus eorum : et factum est illis in scandalum.</p> <p>Et immolaverunt filios suos : et filias suas dæmoniis.</p> <p>Et effuderunt sanguinem innocentem, sanguinem filiorum suorum et filiarum suarum : quas sacrificaverunt sculptilibus Chanaan.</p> <p>Et infecta est terra in sanguinibus, et contaminata est in operibus eorum : et fornicati sunt in adinventionibus suis.</p> <p>Et iratus est furore Dominus in populum suum : et abominatus est hæreditatem suam.</p> <p>Et tradidit eos in manus gentium : et dominati sunt eorum qui oderunt eos.</p> <p>Et tribulaverunt eos inimici eorum : et humiliati sunt sub manibus eorum ; sæpe liberavit eos.</p> <p>Ipsi autem exacerbaverunt eum in consilio suo : et humiliati sunt in iniquitatibus suis.</p> <p>Et vidit eum tribularentur : et audivit orationem eorum.</p> <p>Et memor fuit testamenti sui : et pœnituit eum secundum multitudinem misericordiæ suæ.</p> <p>Et dedit eos in misericordias : in conspectu omnium qui ceperant eos.</p>
---	---	---

thought scorn of the pleasant land promised to them hereafter when they should reign with Christ for ever and ever, and acted as if they had "a continuing city" in this world. Then God gave them their desire, the Visible Church became great and powerful in the world's eyes, but its external prosperity was accompanied by internal weakness, through the heresies and schisms by which it was accompanied, and He "sent leanness withal into their soul." The Church and the world were mingled together, and the former "learned the works" of the latter. Then, again, God "gave them over into the hand of the heathen : " deadly heresies sprung up which culminated in Mahometanism, and what was once the fairest portion of the Church's heritage has for ages been

"oppressed" and "had in subjection" by the enemies of Christ and of His Mystical Body.

Thus, in confessing the sins of Israel in old time, we are also confessing the sins of the Church in later ages : and such confession belongs, not to one period alone, but, in its degree, to all.

It is to be observed also that as, in the preceding Psalm, Joseph is a personal type of Christ in His Providential Office towards the Church, so in this one Moses is a type of Christ in His Mediatorial Office. He continually "stands before God in the gap," and without any such infirmity as that recorded of Moses in the thirty-third verse, He ever holds up His hands in intercession for His people, that they may not be destroyed by their own sins. It is His

The XXI. Day. 45 Deliver us, O Lord our God, and
Evening
Prayer.
1 Chron. xvi. 35,
36.
Dan. ix. 4—19.
gather us from among the heathen :
that we may give thanks unto thy
holy Name, and make our boast of thy
praise.

Ps. xii. 13. 46 Blessed be the Lord God of
Israel from everlasting, and world
without end : and let all the people
say, Amen.

THE CVII PSALM.

Confitemini Domino.

The XXII. Day. **O** GIVE thanks unto the Lord, for
Morning
Prayer.
he is gracious : and his mercy
endureth for ever.

Isa. li. 11.
Rev. v. 9. 2 Let them give thanks whom the
Lord hath redeemed : and delivered
from the hand of the enemy ;

Isa. xxxv. 10. 3 And gathered them out of the
lands, from the east, and from the west :
from the north, and from the south.

Heb. xiii. 14. 4 They went astray in the wilder-
ness out of the way : and found no
city to dwell in ;

5 Hungry and thirsty : their soul
fainted in them.

Matt. v. 4. 6 So they cried unto the Lord in
their trouble : and he delivered them
from their distress.

Heb. xi. 16. 7 He led them forth by the right
way : that they might go to the city
where they dwelt.

8 O that men would therefore praise
the Lord for his goodness : and declare
the wonders that he doeth for the chil-
dren of men ;

John vi. 35. 9 For he satisfieth the empty soul :
and filleth the hungry soul with good-
ness.

Job iii. 5.
xxiv. 17.
xxviii. 3. 10 Such as sit in darkness and in
the shadow of death : being fast bound
in misery and iron ;

Salvos fac nos, Domine, Deus noster :
et congrega nos de nationibus :

Ut confiteamur Nomini sancto tuo :
et gloriemur in laude tua.

Benedictus Dominus Deus Israël a
sæculo et usque in sæculum : et dicet
omnis populus ; Fiat, Fiat.

PSALMUS CVI.

CONFITEMINI Domino, quoniam Sat. Mattins.
bonus : quoniam in sæculum
misericordia ejus.

Dicant qui redempti sunt a Domino :
quos redemit de manu inimici ; et de
regionibus congregavit eos.

A solis ortu et occasu : ab Aquilone
et mari.

Erraverunt in solitudine, in ina- ^{in siccitate . . .}
quoso : viam civitatis habitaculi non ^{habitationis}
invenerunt.

Esurientes et sitientes : anima eorum
in ipsis defecit.

Et clamaverunt ad Dominum cum
tribularentur : et de necessitatibus
eorum eripuit eos. ^{liberavit eos}

Et deduxit eos in viam rectam : ut
irent in civitatem habitationis.

Confiteantur Domino misericordiæ
ejus : et mirabilia ejus filiis hominum.

Quia satiavit animam inanem : et
animam esurientem satiavit bonis.

Sedentes in tenebris et umbra mortis :
vinctos in mendicitate et ferro. ^{et vinculis ligatos}

Voice, speaking from the midst of the Church Militant, which is heard, in the concluding verses of the Psalm, praying that the Captivity of its militant condition may be ended ; and that the glory of God may be perfected by the final redemption of His people. Their confession, "We have sinned with our fathers," is therefore supplemented by the prayer of their Intercessor, "Father, I will that they also, whom Thou hast given Me, be with Me where I am : that they may behold My glory, which Thou hast given Me." [John xvii. 24.] And the doxology of this Psalm (which is also the doxology of the fourth Book) is a type of that hymn of the purified Church, "Amen, Alleluia, Praise our God, all ye His servants, and ye that fear Him, both small and great. Alleluia, for the Lord God Omnipotent reigneth." [Rev. xix. 4—6.]

THE FIFTH BOOK.

PSALM CVII.

The five divisions of this Psalm are each concluded with a doxology in two verses, that at the end of the last division being, as it stands, of a less marked character than the rest, but finding its complement in the *Gloria Patri*. Each division related originally to circumstances connected with the Captivity of the Israelites ; and, in the first four, commentators have found an expansion of the third verse, which refers to the gathering of the people from, and therefore their previous dispersion to, the desert on "the east" of Judæa, Egypt on "the west," Babylon on "the north," and the sea on "the south," where the Red Sea is situated.

The XXII. Day. Morning Prayer.	11 Because they rebelled against the words of the Lord : and lightly regarded the counsel of the most Highest ;	Quia exacerbaverunt eloquia Dei : et consilium Altissimi irritaverunt.
Isa. xxxix. 16.	12 He also brought down their heart through heaviness : they fell down, and there was none to help them.	Et humiliatum est in laboribus eorum : infirmati sunt, nec fuit qui adjuvaret.
	13 So when they cried unto the Lord in their trouble : he delivered them out of their distress.	Et clamaverunt ad Dominum cum tribularentur : et de necessitatibus eorum liberavit eos.
Luke i. 79. Hosea xlii. 14. Job xxxviii. 17.	14 For he brought them out of darkness, and out of the shadow of death : and brake their bonds in sunder.	Et eduxit eos de tenebris et umbra mortis : et vincula eorum dirupit.
	15 O that men would therefore praise the Lord for his goodness : and declare the wonders that he doeth for the children of men ;	Confiteantur Domino misericordie ejus : et mirabilia ejus filiis hominum.
Isa. xlv. 2.	16 For he hath broken the gates of brass : and smitten the bars of iron in sunder.	Quia contrivit portas æreas : et vectes ferreos confregit.
Jonah i. 17.	17 Foolish men are plagued for their offence : and because of their wickedness.	Suscepit eos de via iniquitatis eorum : propter injustitias enim suas humiliati sunt.
	18 Their soul abhorred all manner of meat : and they were even hard at death's door.	Omnem escam abominata est anima eorum : et appropinquerunt usque ad portas mortis.
Jonah ii. 1-10.	19 So when they cried unto the Lord in their trouble : he delivered them out of their distress.	Et clamaverunt ad Dominum cum tribularentur : et de necessitatibus eorum liberavit eos.
Jonah i. 14.	20 He sent his word, and healed them : and they were saved from their destruction.	Misit verbum suum, et sanavit eos : et eripuit eos de interitionibus eorum.
	21 O that men would therefore praise the Lord for his goodness : and declare the wonders that he doeth for the children of men ;	Confiteantur Domino misericordie ejus : et mirabilia ejus filiis hominum.
Jonah ii. 9.	22 That they would offer unto him the sacrifice of thanksgiving : and tell out his works with gladness.	Et sacrificent sacrificium laudis : et annuntient opera ejus in exultatione.

A parallel is found in the prophecy of Isaiah : "Fear not; for I am with thee: I will bring thy seed from the east, and gather thee from the west: I will say to the north, Give up; and to the south, Keep not back: bring My sons from far, and My daughters from the ends of the earth." [Isa. xliii. 5, 6.] Such a gathering of His own Mystical Body the Lord Jesus also predicted when He said, "They shall come from the east, and from the west, and from the north, and from the south, and shall sit down in the Kingdom of God." [Luke xiii. 29.]

The Christian application of the Psalm appears to be to that blessed time when our Lord's words will have received their final and complete fulfilment at the marriage supper of the Lamb, when "the redeemed of the Lord shall return and come with singing unto Zion; and everlasting joy shall be upon their head; they shall obtain gladness and joy; and sorrow and mourning

shall flee away." As, therefore, the Church looks back, in her praises, to past history, recounting God's mercy to her in the days of the Jewish economy, so also does she look forward to the glorious end of all, and sings by anticipation the "new song," "Thou wast slain, and hast redeemed us to God by Thy blood, out of every kindred, and tongue, and people, and nation."

Thus interpreted, the Psalm may be regarded as celebrating (1) the goodness of God to His people in gathering them out of the wilderness of this world into His Church; (2) His comfort of them in the last hour when they "sit in darkness and the shadow of death;" (3) His support of them in the intermediate state; (4) His bringing them to "the haven" of His Presence "where they would be," and (5) His creation of a new Heaven and a new earth, the City of God, for those who have hungered and thirsted after righteousness "to dwell in."

The XXII. Day.
Morning
Prayer.

23 They that go down to the sea in ships : and occupy their business in great waters ;

24 These men see the works of the Lord : and his wonders in the deep.

25 For at his word the stormy wind ariseth : which lifteth up the waves thereof.

26 They are carried up to the heaven, and down again to the deep : their soul melteth away because of the trouble.

27 They reel to and fro, and stagger like a drunken man : and are at their wits' end.

Matt. viii. 25.

28 So when they cry unto the Lord in their trouble : he delivereth them out of their distress.

Matt. viii. 26.

29 For he maketh the storm to cease : so that the waves thereof are still.

John vi. 21.

30 Then are they glad, because they are at rest : and so he bringeth them unto the haven where they would be.

31 O that men would therefore praise the Lord for his goodness : and declare the wonders that he doeth for the children of men ;

Isa. xxxv. 1—10.

32 That they would exalt him also in the congregation of the people : and praise him in the seat of the elders.

33 Who turneth the floods into a wilderness : and drieth up the water-springs.

34 A fruitful land maketh he barren : for the wickedness of them that dwell therein.

35 Again, he maketh the wilderness a standing water : and water-springs of a dry ground.

Matt. v. 6.
Rev. vii. 16.
xxi. 1—27.

36 And there he setteth the hungry : that they may build them a city to dwell in ;

Qui descendunt mare in navibus : facientes operationem in aquis multis.

Ipsi viderunt opera Domini : et mirabilia ejus in profundo.

Dixit, et stetit spiritus procellæ : et exaltati sunt fluctus ejus.

Ascendunt usque ad cœlos, et descendunt usque ad abyssos : anima eorum in malis tabescebat.

Turbati sunt, et moti sunt sicut ebrius : et omnis sapientia eorum de-
dēgluttita est
vorata est.

Et clamaverunt ad Dominum cum tribularentur : et de necessitatibus eorum eduxit eos.

liberavit

Et statuit procellam ejus in auram : et siluerunt fluctus ejus.

Et lætati sunt quia siluerunt : et deduxit eos in portum voluntatis eorum.

voluntatis eorum et de necessitatibus eorum liberavit eos

Confiteantur Domino misericordiam ejus : et mirabilia ejus filiis hominum.

Et exaltem eum in ecclesia plebis : et in cathedra seniorum laudent eum.

Posuit flumina in desertum : et exitus aquarum in sitim.

Quia posuit

Terram fructiferam in salsuginem : a malitia inhabitantium in ea.

Posuit desertum in stagna aquarum : et terram sine aqua in exitus aquarum.

Et collocavit illic esurientes : et constituerunt civitatem habitationis.

The first division, with its doxology¹, is comprised in the first nine verses. It represents the leading into the Church of Christ, "the city where they dwell," of that human nature which had been going astray in the wilderness from the time of the Fall. Departing "out of the way" in which the Creator had placed it, there was still hunger, thirst, and emptiness ; a fainting for the grace of God. Then the Good Shepherd came and led His flock into the right way, gathering them into His one fold, satisfied the empty soul with His grace, and filled the hungry soul with His goodness. Such was His good word, "He that cometh to

¹ These doxologies (verses 8, 9 ; 15, 16 ; 21, 22 ; 31, 32 ; and 42, 43) should be distinctly marked by "full" singing.

Me shall never hunger, and he that believeth on Me shall never thirst."

The second division extends from the tenth to the sixteenth verses inclusive, and celebrates the victory of Christ over that death which had come upon all mankind through the disobedience of their first parents, and the inheritance of a mortal nature by all their descendants. When the Lord saw there was none to help them, His own arm brought salvation. God asked of Job, "Have the gates of death been opened unto thee ? or hast thou seen the doors of the shadow of death ?" but of His "anointed," under the type of Cyrus, He says, "I will loose the loins of kings to open before Him the two-leaved gates ; and the gates shall not be shut : I will go before Thee, and make the crooked places straight : I

The XXII. Day.
Morning
Prayer.

37 That they may sow their land, and plant vineyards : to yield them fruits of increase.

38 He blesseth them, so that they multiply exceedingly : and suffereth not their cattle to decrease.

39 And again, when they are diminished and brought low : through oppression, through any plague, or trouble ;

Matt. v. 10—12.

40 Though he suffer them to be evil intreated through tyrants : and let them wander out of the way in the wilderness ;

Matt. v. 3.
Isa. xliii. 2.
Rev. vii. 16.

41 Yet helpeth he the poor out of misery : and maketh him households like a flock of sheep.

42 The righteous will consider this, and rejoice : and the mouth of all wickedness shall be stopped.

43 Whoso is wise will ponder these things : and they shall understand the lovingkindness of the Lord.

• THE CVIII PSALM.

Paratum cor meum.

Evening
Prayer.
Ascension Day,
Evensong.
Ps. lvii. 8.

O GOD, my heart is ready, my heart is ready : I will sing and give praise with the best member that I have.

Ps. lvii. 9.

2 Awake, thou lute and harp : I my self will awake right early.

Ps. lvii. 10.

3 I will give thanks unto thee, O Lord, among the people : I will sing praises unto thee among the nations.

Ps. lvii. 11.

4 For thy mercy is greater than the heavens : and thy truth reacheth unto the clouds.

Et seminaverunt agros, et plantaverunt vineas : et fecerunt fructum nativitatatis.

Et benedixit eis, et multiplicati sunt nimis : et jumenta eorum non minoravit. *sunt minorata*

Et pauci facti sunt : et vexati sunt a tribulatione malorum et dolore. *et dolorum*

Effusa est contemptio super principes : et errare fecit eos in invio, et non in via. *et seducerunt eos*

Et adjuvit pauperem de inopia : et posuit sicut oves familias. *adjuvavit*

Videbunt recti, et lætabuntur : et omnis iniquitas oppilabit os suum. *oppilavit*

Quis sapiens, et custodiet hæc : et intelliget misericordias Domini.

PSALMUS CVII

PARATUM cor meum, Deus, paratum cor meum : cantabo et psallam in gloria mea. *Sat. Mattins. psalmum dicam Domino*

Exsurge gloria mea, exsurge psalterium et cithara : exsurgam diluculo.

Confitebor tibi in populis, Domine : et psallam tibi in nationibus.

Quia magna est super celos misericordia tua : et usque ad nubes veritas tua. *Quoniam magnificata est usque ad celos*

will break in pieces the gates of brass, and cut in sunder the bars of iron." So has the Lord Jesus overcome for His people that they can say, "O death, where is thy sting? O grave, where is thy victory?"

The third division, verses 17—22, and the fourth division, verses 23—32, both refer to the work of the Redeemer for His Church in the intermediate state, when the WORD, which had become flesh that mankind might be "healed," descended into Hell that He might carry His power even to the regions where the souls of men were "hard at the door of" eternal "death," and only that power could save them from final destruction. The representation of the Intermediate State under the figure of men in the midst of the deep is illustrated by the punishment of Jonah, which our Lord interprets as a figure of His own abiding for three days in the "heart of the earth." [Matt. xii. 40.] A further illustration may also be found in the miracle wrought by our Lord when the disciples were overtaken in a storm : "they willingly received Him into the ship: and immediately the ship was at the land whither they went."

The fourth division, from the thirty-third verse to the end, celebrates, by anticipation, the rest and glory of Christ's Church when it has passed from the wilderness of this world, and been gathered in for ever to that City of God where the river of the water of life flows through the midst of its streets : where the Mystical Body of the POOR is helped out of misery for ever, and there is one fold and one Shepherd. In view of that blessed consummation of His Church's pilgrimage, "the righteous will consider this, and rejoice," and whatever may be the troubles attending it in life or in death, "they shall understand the loving-kindness of the Lord" in all His dealings with His people.

PSALM CVIII.

There is scarcely any variation between the words of this Psalm and those verses of the fifty-seventh and sixtieth which are indicated in the margin. The two portions combined form a hymn of victory, the spiritual meaning of which is shown by the appropriation of the Psalm to Ascension Day. It is the voice of the Church offering up her Eucharistic Sacrifice before the throne in

The XXII. Day.
Evening
Prayer.
Ps. lvii. 12.

5 Set up thy self, O God, above the heavens : and thy glory above all the earth.

Ps. lx. 5.

6 That thy beloved may be delivered : let thy right hand save them, and hear thou me.

Ps. lx. 6.

7 God hath spoken in his holiness : I will rejoice therefore and divide Sichem, and mete out the valley of Succoth.

Ps. lx. 7.

8 Gilead is mine, and Manasses is mine : Ephraim also is the strength of my head.

Ps. lx. 8.

9 Juda is my law-giver, Moab is my wash-pot : over Edom will I cast out my shoe ; upon Philistia will I triumph.

Ps. lx. 9.

10 Who will lead me into the strong city : and who will bring me into Edom ?

Ps. lx. 10.

11 Hast not thou forsaken us, O God : and wilt not thou, O God, go forth with our hosts ?

Ps. lx. 11.

12 O help us against the enemy : for vain is the help of man.

Ps. lx. 12.

13 Through God we shall do great acts : and it is he that shall tread down our enemies.

THE CIX PSALM.

Deus laudum.

Job i. 6-12.
ii. 1-7.
Rev. xii. 10.
1 Pet. v. 8.
Zech. iii. 1.

HOLD not thy tongue, O God of my praise : for the mouth of the ungodly, yea the mouth of the deceitful is opened upon me.

Ps. xxxv. 11.

2 And they have spoken against me with false tongues : they compassed me about also with words of hatred, and fought against me without a cause.

3 For the love that I had unto them, lo, they take now my contrary part : but I give my self unto prayer.

Ps. xxxv. 12.

4 Thus have they rewarded me evil for good : and hatred for my good will.

Exaltare super cœlos, Deus, et super omnem terram gloria tua : ut liberentur dilecti tui.

electi

Salvum fac dextera tua, et exaudi me : Deus locutus est in sancto suo.

Exultabo et dividam Sichimam : et convallem tabernaculorum dimetiar.

Labor . . . labor

Meus est Galaad, et meus est Manasses : et Ephraim susceptio capitis mei.

fortitudo capitis

Juda rex meus : Moab lebes spei meæ.

olla spei

In Idumæam extendam calcamentum meum : mihi alienigenæ amici facti sunt.

alioquili subditi sunt

Quis deducet me in civitatem munitam ? quis deducet me usque in Idumæam ?

Nonne tu, Deus, qui repulisti nos : et non exhibis Deus in virtutibus nostris.

egredieris

Da nobis auxilium de tribulatione : quia vana salus hominis.

In Deo faciemus virtutem : et ipse ad nihilum deducet inimicos nostros.

tribulant nos

PSALMUS CVIII.

DEUS, laudem meam ne tacueris : quia os peccatoris et os dolosi super me apertum est.

Locuti sunt adversum me lingua dolosa : et sermonibus odii circumderunt me, et exptgnaverunt me gratis.

Pro eo ut me diligerent, detrahebant mihi : ego autem orabam.

Et posuerunt adversum me malâ probationis : et odium pro dilectione mea.

the Person of the ascended Jesus, the Head of all His members : "Behold, I see the heavens opened, and the Son of Man standing on the right hand of God." [Acts vii. 56.]

PSALM CIX.

When our Blessed Lord offered up to the Father the prayer which forms the seventeenth chapter of St. John's Gospel, He used words which give us a key to the meaning of this awful Psalm, "While I was with them in the world, I kept them in Thy Name : those that Thou gavest Me I have kept, and none of them is lost, but, the son of perdition ; that the Scripture might

be fulfilled." [John xvii. 12.] The "son of perdition" has always been understood to mean Judas, of whom two Evangelists record that "Satan entered into him." These words are a Divine illustration of the fifth verse of the Psalm, "Let Satan stand at his right hand." The seventh verse was also distinctly quoted by St. Peter a few days later, as among the words which the Holy Ghost had spoken before "concerning Judas," "His bishopric let another take." We thus have the highest possible warrant for interpreting this Psalm as a Prayer of the Redeemer spoken prophetically of His betrayal, spoken against him who betrayed Him, and against Satan the "ungodly" and "deceitful," the great

The XXII. Day. 5 Set thou an ungodly man to be ruler over him : and let Satan stand at his right hand.

Evening Prayer.
John xlii. 27.
Luke xxii. 3.
Cf. Ps. lxxix. 23—29.
Prov. xv. 8.
xxviii. 9.

6 When sentence is given upon him, let him be condemned : and let his prayer be turned into sin.

Acts i. 20. 7 Let his days be few : and let another take his office.

Exod. xxii. 24.
Jer. xviii. 21. 8 Let his children be fatherless : and his wife a widow.

Gen. iv. 12. 9 Let his children be vagabonds, and beg their bread : let them seek it also out of desolate places.

Matt. v. 26. 10 Let the extortioner consume all that he hath : and let the stranger spoil his labour.

Ezek. v. 11. 11 Let there be no man to pity him : nor to have compassion upon his fatherless children.

12 Let his posterity be destroyed : and in the next generation let his name be clean put out.

Gen. iii. 17. 13 Let the wickedness of his fathers be had in remembrance in the sight of the Lord : and let not the sin of his mother be done away.

14 Let them alway be before the Lord : that he may root out the memorial of them from off the earth :

Matt. xxiii. 35. 15 And that, because his mind was not to do good : but persecuted the poor helpless man, that he might slay him that was vexed at the heart.

Matt. xxvii. 25. 16 His delight was in cursing, and it shall happen unto him : he loved not blessing, therefore shall it be far from him.

17 He clothed himself with cursing, like as with a raiment : and it shall come into his bowels like water, and like oil into his bones.

Constituere super eum peccatorem : et diabolus stet a dextris ejus.

Cum judicatur, exeat condemnatus : et oratio ejus fiat in peccatum.

In peccatum. Fiat habitatio ejus deserta et non sit qui habitet in ea. Fiat dies.

Fiant dies ejus pauci : et episcopatum ejus accipiat alter.

Fiant filii ejus orphani : et uxor ejus vidua.

Nutantes transferantur filii ejus et mendicent : et ejiciantur de habitacionibus suis. *Commoti amoveantur filii*

Scrutetur fenerator omnem substantiam ejus : et diripiant alieni labores ejus.

Non sit illi adjutor : nec sit qui misereatur pupillis ejus.

Fiant nati ejus in interitum : in generatione una deleatur nomen ejus.

In memoriam redeat iniquitas patrum ejus in conspectu Domini : et peccatum matris ejus non deleatur.

Fiant contra Dominum semper, et dispereat de terra memoria eorum : pro eo quod non est recordatus facere misericordiam :

Et persecutus est hominem inopem et mendicum : et compunctum corde mortificare. *mortis tradidit*

Et dilexit maledictionem, et veniet ei : et noluit benedictionem, et elongabitur ab eo.

Et induit maledictionem sicut vestimentum : et intravit sicut aqua in interiora ejus, et sicut oleum in ossibus ejus.

Accuser of Job (a personal type of our suffering Lord), and of "our brethren . . . which accused them before our God day and night." And thus, while the awful imprecations of the Psalm have reference to Judas, they have also reference, in a still greater degree, to the great Adversary of God and man by whom Judas was possessed ; and they are used in this latter sense by the Church of Christ. The constant, vigilant enmity of that Adversary is shown by the words just quoted from the Revelation. "Day and night" his accusations are being made before God against the Mystical Body of Christ, with the same malice as against the Holy One Himself before the earthly tribunal : and the terms of the Psalm lead us to suppose that these accusations are not only those which may justly be made against sinners, but also the slanderous inventions of him who is the "father of lies."

As Christ is heard speaking, therefore, in this Psalm, with regard to His Betrayal, so also is He heard speaking in and for His Mystical Body with regard to its persecution before the throne of God, by the slanders of Satan. So far as they who wilfully take part in this work of Satan are alluded to in the Psalm, they are spoken of as the enemies of Christ : and those who, having utterly and finally rejected Him and His mercies, have cut themselves off from the operation of His redemption and pardon, find there is "no Man to pity them." [See former remarks on the Imprecations, at page 410.] Nothing can more awfully set forth the danger of speaking against Christ ; or (what is more likely to be done in these days) of making slanderous accusations against His Church, the Temple of the Holy Ghost. "Whosoever speaketh against the Holy Ghost, it shall

The XXII. Day.
Evening
Prayer.

18 Let it be unto him as the cloke that he hath upon him : and as the girdle that he is alway girded withal.

19 Let it thus happen from the Lord unto mine enemies : and to those that speak evil against my soul.

20 But deal thou with me, O Lord God, according unto thy Name : for sweet is thy mercy.

Zech. iii. 3.

21 O deliver me, for I am helpless and poor : and my heart is wounded within me.

22 I go hence like the shadow that departeth : and am driven away as the grasshopper.

23 My knees are weak through fasting : my flesh is dried up for want of fatness.

Mark xv. 29.

24 I became also a reproach unto them : they that looked upon me shaked their heads.

25 Help me, O Lord my God : O save me according to thy mercy ;

26 And they shall know, how that this is thy hand : and that thou, Lord, hast done it.

27 Though they curse, yet bless thou : and let them be confounded that rise up against me ; but let thy servant rejoice.

Ps. xxxv. 26.

28 Let mine adversaries be clothed with shame : and let them cover themselves with their own confusion, as with a cloke.

Ps. xxxv. 28.
Heb. ii. 12.

29 As for me, I will give great thanks unto the Lord with my mouth : and praise him among the multitude ;

Zech. iii. 2. 4.
Rev. xii. 10.

30 For he shall stand at the right hand of the poor : to save his soul from unrighteous judges.

The XXIII.

Day.
Morning

Prayer.
Christmas Day,
Evensong;
Matt. xxii. 44.
Mark xii. 36.
Luke xx. 42.
Acts ii. 34.
Heb. i. 13.

THE CX PSALM.

Dixit Dominus.

THE Lord said unto my Lord : Sit thou on my right hand, until I make thine enemies thy footstool.

Fiat ei sicut vestimentum quo operitur : et sicut zona qua semper præcingitur.

Hoc opus eorum qui detrahunt mihi apud Dominum : et qui loquuntur mala adversus animam meam.

Et tu, Domine, Domine, fac mecum mecum misericordiam propter propter Nomen tuum : quia suavis est misericordia tua.

Libera me, quia egenus et pauper ego sum : et cor meum conturbatum est intra me.

Sicut umbra cum declinat ablatus sum : et excussus sum sicut locustæ.

Genua mea infirmata sunt a jejunio : et caro mea immutata est propter oleum.

Et ego factus sum opprobrium illis : viderunt me, et moverunt capita sua.

Adjuva me, Domine, Deus meus : salvum me fac secundum misericordiam tuam.

Et sciant quia manus tua hæc : et tu, Domine, fecisti eam.

Maledicent illi, et tu benedices : qui insurgunt in me confundantur ; servus autem tuus lætabitur.

Induantur qui detrahunt mihi mihî reverentia pudore : et operiantur sicut diploide confusione sua.

Confitebor Domino nimis in ore meo : et in medio multorum laudabo eum.

Qui astitit a dextris pauperis : ut salvam faceret a persequentibus animam meam.

PSALMUS CIX.

DIXIT Dominus Domino meo : Sunday, Christmas, App. and Evv., Vespers. Sede a dextris meis :

Donec ponam inimicos tuos : scabellum pedum tuorum.

not be forgiven him, neither in this world, nor in the world to come¹. [Matt. xii. 32.]

¹ All readers are affectionately warned of the danger which hangs about any words spoken in depreciation of the Sacraments, or of the work of priests and bishops, the efficacy of which is entirely derived from the Holy Ghost. "Such words as "the soul-destroying doctrine of Baptismal Regene-

The last verse of the Psalm brings out very strongly the completeness of that deliverance which God will give to the Mystical Body of Christ from the accusations of Satan. The Accuser stands at the right hand of the Betrayed and the Slanderer as

ration" were once quite common ; and fearfully intemperate language has been used respecting the Presence of Christ in the Holy Communion.

The XXIII.
Day.
Morning
Prayer.
Matt. xxvi. 64.
Matt. i. 11.
Rev. iv. 1-11.
xix.

2 The Lord shall send the rod of thy power out of Sion : be thou ruler, even in the midst among thine enemies.

3 In the day of thy power shall the people offer thee free-will offerings with an holy worship : the dew of thy birth is of the womb of the morning.

Heb. v. 6.
vii. 17-21.

4 The Lord sware, and will not repent : Thou art a Priest for ever after the order of Melchisedech.

Rev. xix. 11-18.

5 The Lord upon thy right hand : shall wound even kings in the day of his wrath.

Rev. xx. 11-15.
1 Cor. xv. 26. 55.

6 He shall judge among the heathen ; he shall fill the places with the dead bodies : and smite in sunder the heads over divers countries.

Mark xvi. 19.
Heb. i. 3. x. 12.

7 He shall drink of the brook in the way : therefore shall he lift up his head.

THE CXI PSALM.

Confitebor tibi.

Easter Day,
Mattins.

I WILL give thanks unto the Lord with my whole heart : secretly among the faithful, and in the congregation.

Virgam virtutis tuæ emittet Dominus ex Sion: dominare in medio inimicorum tuorum. et dominaveris

Tecum principium in die virtutis tuæ, in splendoribus sanctorum: ex utero ante luciferum genui te.

Juravit Dominus, et non pœnitebit eum: Tu es Sacerdos in æternum secundum ordinem Melchisedech.

Dominus a dextris tuis: confregit in die iræ suæ reges. confringit

Judicabit in nationibus; implebit ruinas: conquassabit capita in terra multorum. terra copiosa

De torrente in via bibet: propterea exaltabit caput.

PSALMUS CX.

CONFITEBOR tibi, Domine, in toto corde meo: in consilio justorum, et congregatione. in Sunday, Christmas, Vespers.

well as at the right hand of "Joshua the High Priest;" but while in the one case the words are heard "Let him be condemned," in the other the words are "The Lord rebuke thee, O Satan; even the Lord that hath chosen Jerusalem rebuke thee: is not this a brand plucked out of the fire?" Thus God Himself shall stand at the right hand of the Poor to save his soul from unrighteous judges. And thus the prophecy will be fulfilled, "I heard a loud voice saying in Heaven, Now is come salvation, and strength, and the Kingdom of our God, and the power of His Christ: for the Accuser of our brethren is cast down, which accused them before our God day and night."

PSALM CX.

Our Lord and His Apostles distinctly certify to us that this Psalm is spoken of the Messiah, by quoting the first and the fourth verses and applying them to Him. It is, in fact, quoted in the New Testament more than any other Psalm; and may be taken,—as Christ's use of it shows,—as a treasury of Mystical truth respecting the Kingship and Priesthood of the Son of Man.

In the first words there is a revelation of the First and Second Persons of the Holy Trinity, since they are spoken by the Father to the Son. They are also considered to contain a reference to the Third Person, since it was by the Holy Ghost descending on the Son of Man that He was consecrated to that work by means of which His Human Nature attained to the glory of the Father's right hand. In the words "My Lord" has also been observed a prophecy of the Incarnation, David speaking of Christ as his because He was descended from him, as his Lord, because He was the Son of God.

The second verse proclaims the Kingship and Kingdom of Christ, both proceeding forth from the elder Church of God, and prevailing even over the Gentiles who had for so long been the enemies of God, ruling with a rod of iron, the sceptre of His power and redeeming love, the power and love of the Incarnation.

To His Royal Person in "the Lord's Day" of the Incarnation the wise men were to bring offerings of gold, frankincense, and myrrh: to it the Church will be rendering the homage of Divine worship for ever in earth and in Heaven; recognizing in the Holy Child Jesus the Day Star from on high, the Sun of Righteousness arising with healing in His beams.

And as the Kingship of Christ is here commemorated in holy song, so also is His eternal and supreme Priesthood, by which He offers up Himself as a perpetual Sacrifice before the throne of God, and from the Fountain of which originate all the streams of grace by which the Church waters and refreshes the world.

The Victory of the Messiah in the Resurrection and the Judgment is prefigured in the fifth and sixth verses. He will go forth conquering and to conquer, all things will be put under His feet, He will cause the dead both small and great to stand before His throne of righteous judgment, and will destroy even the last enemy; so that when the graves are opened and the sea gives up her dead, and everlasting life dawns on the redeemed, they will say, "O Death, where is thy sting? O Grave, where is thy victory?"

So shall the Lord Jesus bruise the head of the tempter for ever, and His own head shall be lifted up in eternal triumph. He drank of the water-floods which ran over Him in His Passion, and so was His prophecy fulfilled, "I, if I be lifted up, will draw all men unto Me."

PSALM CXI.¹

The praises of the Church are here offered to God for the spiritual works which He has wrought through the "grace and truth" which "came by Jesus Christ." The "works of the Lord" are, therefore, those works the power and efficacy of

¹ This is one of the "alphabet Psalms," each verse or clause successively, in the Hebrew, beginning with the successive letters of the alphabet.

The XXIII.
Day.
Morning
Prayer.
Isa. lxxv. 1.

2 The works of the Lord are great : sought out of all them that have pleasure therein.

3 His work is worthy to be praised, and had in honour : and his righteousness endureth for ever.

Rev. xv. 3.

4 The merciful and gracious Lord hath so done his marvellous works : that they ought to be had in remembrance.

John vi. 27. 35.
Rev. ii. 17.

5 He hath given meat unto them that fear him : he shall ever be mindful of his covenant.

6 He hath shewed his people the power of his works : that he may give them the heritage of the heathen.

Rev. xv. 3.

7 The works of his hands are verity and judgement : all his commandments are true.

8 They stand fast for ever and ever : and are done in truth and equity.

Isa. xlv. 8.
John i. 14. 17.
Phil. ii. 10.

9 He sent redemption unto his people : he hath commanded his covenant for ever ; holy and reverend is his Name.

Prov. i. 7.

10 The fear of the Lord is the beginning of wisdom : a good understanding have all they that do thereafter ; the praise of it endureth for ever.

THE CXII PSALM.

Beatus vir.

Cf. Prov. xi. 16-31.

BLESSED is the man that feareth the Lord : he hath great delight in his commandments.

Isa. liii. 10.

2 His seed shall be mighty upon earth : the generation of the faithful shall be blessed.

3 Riches and plenteousness shall be in his house : and his righteousness endureth for ever.

Magna opera Domini : exquisita in omnes voluntates ejus.

Confessio et magnificentia opus ejus : et justitia ejus manet in sæculum sæculi.

Memoriam fecit mirabilium suorum ; misericors et miserator Dominus : escam dedit timentibus se.

Memor erit in sæculum testamenti sui : virtutem operum suorum annuntiabit populo suo :

Ut det illis hæreditatem gentium : opera manuum ejus veritas et judicium.

Fidelia omnia mandata ejus ; confirmata in sæculum sæculi : facta in veritate et æquitate.

Redemptionem misit Dominus populo suo : mandavit in æternum testamentum suum.

Sanctum et terribile Nomen ejus : initium sapientiæ timor Domini.

Intellectus bonus omnibus facientibus eum : laudatio ejus manet in sæculum sæculi.

PSALMUS CXI.

BEATUS vir qui timet Dominum : in mandatis ejus volet nimis. Sunday, Christmas, Vespers. *cupiet*

Potens in terra erit semen ejus : generatio rectorum benedicetur.

Gloria et divitiæ in domo ejus : et justitia ejus manet in sæculum sæculi.

which proceed from the Person of God Incarnate. Hence the subject of praise in this Psalm is our Lord Himself as the source of redemption, grace, and salvation : "I am sought of them that asked not for Me: I am found of them that sought Me not." "To him that overcometh will I give to eat of the hidden manna." "Great and marvellous are Thy works, Lord God Almighty: just and true are Thy ways, Thou King of saints."

PSALM CXII.¹

Our Lord's words, "It is more blessed to give than to receive" [Acts xx. 35], offer a comprehensive illustration of this Psalm, which recounts the blessedness of the Man Christ Jesus, Who "is

¹ This is also an alphabet Psalm.

merciful and lendeth" the talents of His grace, Who "hath dispersed abroad and given to the poor" of the bounties of His mercy.

In His perfect obedience to the will of His Father our Lord became the source of regeneration to mankind, and in Him the prophecy was fulfilled, "He shall see His seed, He shall prolong His days." Thus, having originated a new people, the riches and plenteousness of His grace are stored up in His Church for them: and He is the "good Man" Who scattereth and yet increaseth, and Who in His mercifulness so bestows His grace that He can say to His Church respecting it, "Freely ye have received, freely give."

These indications of a spiritual interpretation of this Psalm will be a guide to further development of it in the same direction:

The XXIII.
Day.
Morning
Prayer.
Isa. lviii. 10.
Ix. 1.
Matt. xiv. 43.
Luke xix. 13.

4 Unto the godly there ariseth up light in the darkness : he is merciful, loving, and righteous.

5 A good man is merciful, and lendeth : and will guide his words with discretion.

6 For he shall never be moved : and the righteous shall be had in everlasting remembrance.

7 He will not be afraid of any evil tidings : for his heart standeth fast, and believeth in the Lord.

8 His heart is established, and will not shrink : until he see his desire upon his enemies.

2 Cor. ix. 23, 24.
Prov. xi. 9.

9 He hath dispersed abroad, and given to the poor : and his righteousness remaineth for ever ; his horn shall be exalted with honour.

Luke xiii. 28.
Matt. viii. 12.
xiv. 42.
xxv. 30.

10 The ungodly shall see it, and it shall grieve him : he shall gnash with his teeth, and consume away ; the desire of the ungodly shall perish.

THE CXIII PSALM.

Laudate, pueri.

Easter Day,
Evensong.
Cf. Magnificat.

PRAISE the Lord, ye servants :
O praise the Name of the Lord.

2 Blessed be the Name of the Lord : from this time forth for evermore.

Mal. i. 11.
iv. 2.

3 The Lord's Name is praised : from the rising up of the sun, unto the going down of the same.

4 The Lord is high above all heathen : and his glory above the heavens.

Exortum est in tenebris lumen rectis :
misericors, et miserator, et justus.

*corde misericors
... et justus
Dominus*

Jucundus homo qui miseretur et commodat ; disponet sermones suos in judicio : quia in æternum non commovebitur.

In memoria æterna erit justus : ab auditu
auditione mala non timebit.

Paratum cor ejus sperare in Domino ; confirmatum est cor ejus : non commovebitur donec despiciat inimicos
suos.

Dispersit, dedit pauperibus ; justitia ejus manet in sæculum sæculi : cornu ejus exaltabitur in gloria.

Peccator videbit et irascetur ; dentibus suis fremet et tabescet : desiderium peccatorum peribit.

PSALMUS CXII.

LAUDATE, pueri, Dominum :
laudate Nomen Domini.

*Sund., App. and
Evv., Vespers
Christmas,
1st Vespers.*

Sit Nomen Domini benedictum :
ex hoc nunc et usque in sæculum.

A solis ortu usque ad occasum :
laudabile Nomen Domini.

Excelsus super omnes gentes Domi-
nus : et super celos gloria ejus.

especially when considered in connexion with the remarkable parallel expressions in the eleventh chapter of Proverbs, and with the passages referred to in the margin opposite to the fifth and tenth verses.

PSALMS CXIII.—CXVIII.

THE GREAT HALLELUJAH.

"And when they had sung an hymn, they went out into the Mount of Olives."—*Mark xiv. 26.*

The group of Psalms which begins with the hundred and thirteenth and ends with the hundred and eighteenth is endowed with a special character as a link between the Old Dispensation and the New above all the rest of the Psalms. At the time of the Passover it was the custom of the Jewish ritual to sing the hymn made up of these six Psalms partly in the Temple, and partly at home, under the title of the Great Hallelujah, the hymn beginning with that word, and having it also in several other places. The first three of the Psalms of which it is composed were sung "in the courts of the Lord's house" during the time occupied by slaying the Passover lambs: the latter three, beginning "I am well pleased," were sung in the room in which

the Passover lamb had been eaten, and at the conclusion of all the ceremonies connected with the Supper.

Whether the Great Hallelujah was composed for this purpose or not, there are several historical and local expressions in it which indicate its fitness for use at the Passover. The first division, for public use in the Temple, is a hymn of thanksgiving to the Lord for His mercy and loving-kindness to the people of Israel: a national hymn in which the distinctive position of the separated nation is prominently kept in view, and the Lord praised as the God of Israel. The hundred and thirteenth and hundred and fourteenth Psalms are supposed to have been written for the foundation of the second Temple by Ezra. In the first of these the allusion to the worship of God "from the rising up of the sun unto the going down of the same," seems to give evidence of a travelled people who had retained their true faith and religious customs in a distant land, and among the heathen who are named directly afterwards. Then the praise of the condescension of the Lord of Heaven towards the simple and poor, who had lain in the dust and the mire, but was now being lifted up by Him to be set among princes, speaks the natural feeling of those who had returned from the Captivity, and were once more beginning a national existence: while in "the barren

The XXIII.

Day.
Morning
Prayer.
John i. 1. 14.
Phil. ii. 6.

5 Who is like unto the Lord our God, that hath his dwelling so high : and yet humbleth himself to behold the things that are in heaven and earth.

1 Sam. ii. 8.

6 He taketh up the simple out of the dust : and lifteth the poor out of the mire.

7 That he may set him with the princes : even with the princes of his people.

1 Sam. ii. 5.
Isa. viii. 18.
liv. 1.
Gal. iv. 27.

8 He maketh the barren woman to keep house : and to be a joyful mother of children.

THE CXIV PSALM.

In exitu Israel.

Evening
Prayer.
Easter Day,
Evensong.
Hosea xi. 1.
Matt. ii. 15.
Ps. lxxx. 5.
1 Cor. x. 1-11.

WHEN Israel came out of Egypt : and the house of Jacob from among the strange people,

2 Judah was his sanctuary : and Israel his dominion.

Quis sicut Dominus Deus noster, qui in altis habitat : et humilia respicit in cœlo et in terra ?

Suscitans a terra inopem : et de stercore erigens pauperem :

Ut collocet eum cum principibus : cum principibus populi sui.

Qui habitare facit sterilem in domo : matrem filiorum lætantem.

PSALMUS CXIII.

IN exitu Israël de Ægypto : domus Jacob de populo barbaro :

Facta est Judæa sanctificatio ejus : Israël potestas ejus.

potestas ejus
Israel regnavit
in ea

woman" we see the long-desolated Church of Israel once more about to "keep house" in the Holy City and be a joyful mother of children to be added to the household of God. The following Psalm, the hundred and fourteenth, refers to still more ancient mercies of God towards His people, when He took them out of their Egyptian bondage, and after their long miraculous sustenance by means of the stream which sprung from the rock in the wilderness, cleft the waters of Jordan in two, as He had done those of the Red Sea, that He might make a way for Israel to go to their home, the land which was to be marked so signally as the sanctuary and dominion of the Lord. Such national mercies of old time lead on, through the humble acknowledgment "Not unto us, O Lord, not unto us, but unto Thy Name give the praise," to an expression of faith and confidence in the continued loving-kindness of the Lord and in His providential care for Israel. A small band,—on their return from captivity, and even at the best of times,—among the heathen round about, yet the Lord's manifest dealings towards them are an answer to the taunt which had been cast upon them by those heathen on account of the depressed state of Israel, "Where is now their God?" What evidence could Heathendom give to prove any Providence exercised by their idols, though they were idols of silver and idols of gold? But for the house of Israel and the Priesthood of Aaron there was abundant reason for trusting in God, who had shown Himself to be their succour and defence in past ages, and would show Himself the same in time to come towards those who feared Him with the loving reverence of filial fear. The Lord had sent His people into captivity for their national sins, but He had not forsaken them altogether; He would still bless the separated nation, and the separated priesthood, and show once more that they were His chosen. Such is the substance of the hymn sung in the Temple, which ends as it began with the sacred and joyous cry, "Hallelujah."

The second portion of the hymn is all written in the first person, with the exception of the two verses numbered as the hundred and seventeenth Psalm, which seem to be a choral refrain taking up the burden of the Temple part of the hymn, and so connecting the private and the public divisions of it. In this there are several references to the Passover itself. The "cup of salvation" cannot but have referred to the cup of wine over which a

Benediction was said, and which was partaken of several times during the supper as a part of the ritual of the Passover. "Bind the sacrifice with cords, yea, even unto the horns of the altar," is a memorial of the offering made in the Temple, and upon which the household has been reverently feasting at home. So also with the verse, "I will offer to Thee the sacrifice of thanksgiving . . . I will pay my vows." And not less distinct is the local application of the words "The voice of joy and health is in the dwellings of the righteous," and of "This is the day which the Lord hath made: we will rejoice and be glad in it:" while throughout this portion of the hymn, as of the other, there are references to the circumstances of the first Passover and the early history of Israel which unite the thanksgivings for present mercies to commemorations of the never-to-be-forgotten providence of God's hand in ancient days.

But, draw out the meaning and the application of this hymn as we will, it is impossible not to feel that these are so far from being exhausted by their connexion with the Old Dispensation that they seem only like morsels of gold lying upon the surface which point out to the observant eye the place where rich veins of treasure are to be found by deeper research. This is especially the case with the latter portion, beginning "I am well pleased," and a flood of light is thrown upon the whole of the Great Hallelujah by the use of this portion under the circumstances narrated by St. Mark, "When they had sung an hymn, they went out into the Mount of Olives."

For the moment at which this hymn was sung by our Blessed Saviour and His Apostles was the crisis of the Old and New Dispensation, when the Passover sacrifice was about to be merged in that great Sacrifice of the Lamb of God whereof it was the type, when the Passover Supper was vanishing before the Supper of the Lord then instituted, when typical shadows were about to become sacramental realities, and when the hidden words of this prophetic hymn were to receive their full interpretation in the woful, yet glorious, work of the three following days. It is in the light so shed upon the Great Hallelujah that it is to be viewed now that it is used in Divine Service and by Christian worshippers: in that Light in which we shall see light; as the Hallelujah of Him Who, when He had sung it, went forth to the Mount of Olives, to Gethsemane, and to Calvary.

The XXIII.
Day.
Evening
Prayer.
Hab. iii. 6-10.

3 The sea saw that, and fled : Jordan was driven back.

4 The mountains skipped like rams : and the little hills like young sheep.

5 What aileth thee, O thou sea, that thou fleddest : and thou Jordan, that thou wast driven back ?

6 Ye mountains, that ye skipped like rams : and ye little hills, like young sheep ?

7 Tremble, thou earth, at the presence of the Lord : at the presence of the God of Jacob ;

8 Who turned the hard rock into a standing water : and the flint-stone into a springing well.

Mic. vi. 1, 2.
Heb. xii. 26.
Rev. xvi. 20.

Isa. xli. 18.
Zech. xiii. 1.
John iv. 14.

THE CXV PSALM.

Non nobis, Domine.

Isa. xlviii. 2, 11.

NOT unto us, O Lord, not unto us, but unto thy Name give the praise : for thy loving mercy, and for thy truth's sake.

Ps. lxxix. 10.
2 Pet. iii. 4.

2 Wherefore shall the heathen say : Where is now their God ?

Ecd. viii. 3.
Dan. iv. 35.

3 As for our God, he is in heaven : he hath done whatsoever pleased him.

Isa. xli. 7.
Ps. cxxxv. 15.

4 Their idols are silver and gold : even the work of men's hands.

Ps. cxxxv. 16.

5 They have mouths, and speak not : eyes have they, and see not.

Ps. cxxxv. 17.

6 They have ears, and hear not : noses have they, and smell not.

Mare vidit, et fugit : Jordanis conversus est retrorsum.

Montes exsultaverunt ut arietes : et colles sicut agni ovium.

Quid est tibi, mare, quod fugisti : et tu Jordanis, quia conversus es retrorsum ?

Montes exsultastis sicut arietes : et colles sicut agni ovium.

A facie Domini mota est terra : a facie Dei Jacob.

Qui convertit petram in stagna aquarum : et rupem in fontes aquarum.

[PSALMUS CXIII. v. 9.]

Non nobis Domine, non nobis : sed Nomini tuo da gloriam.

Super misericordia tua et veritate tua : nequando dicant gentes, Ubi est Deus eorum ?

Deus autem noster in cœlo : omnia quæcunque voluit, fecit.

Simulachra gentium argentum, et aurum : opera manuum hominum.

Os habent, et non loquentur : oculos habent, et non videbunt.

Aures habent, et non audiunt : nares habent, et non odorabunt.

PSALM CXIII.—The first three Psalms of this series are of a much less individual character in their language than the later three ; and are thus to be taken as the voice of the Church, while the others are the Voice of Christ Himself. In the 113th, the Church praises God for the rising of the Sun of Righteousness upon her, and with Him shining in the midst, speaks in the tone of Malachi's Eucharistic prophecy : " From the rising of the sun unto the going down of the same, My Name shall be great among the Gentiles, and in every place incense shall be offered unto Me, and a pure offering, for My Name shall be great among the heathen, saith the Lord of hosts." [Mal. i. 11.] Looking forward to Christ's " lifting up " to the throne of the Cross, He is beheld also rising again to His Easter throne of victory and everlasting dominion, taken up out of the dust of death, and set " far above all principality, and power, and might, and dominion, and every name that is named, not only in this world, but also in that which is to come." [Eph. i. 22.] And this glory of Christ is seen to be also the glory of " the Church, which is His Body, the fulness of Him that filleth all in all " [Ibid. 23] : so that the Psalm ends with words of rejoicing which also find their parallel in prophecy : " Sing, O barren, thou that didst not bear : break forth into singing, and cry aloud, thou that didst not travail with child : for more are the children of the desolate, than the children of the married wife saith the Lord."

PSALM CXIV.—The same strain is continued in the next of the series ; in which it must be understood that the ancient Israel and the Gentiles have changed places, and that the former being rejected the latter have been accepted in their stead¹. " The coming forth of Israel from Egypt is to be taken, therefore, as the taking of His little flock (soon to become a great people) out from among the world, by Christ ; and the succeeding verses are to be interpreted in the sense which was given by the coming of Christ to the ancient prophecy : " Every valley shall be exalted, and every mountain and hill shall be made low, and the crooked shall be made straight, and the rough places plain : and the glory of the Lord shall be revealed, and all flesh shall see it together, for the mouth of the Lord hath spoken it." [Isa. xl. 4, 5.] When that glory was revealed the Rock of Ages became a sacramental Fountain of life, opened for all uncleanness : and from the Corner-Stone flowed forth a springing well of grace, whose waters are for the refreshment of every age.

PSALM CXV.—The third of the series still proclaims the great work of salvation about to be wrought in the sufferings and glory of Christ : but the tone is rather that of confident faith in some-

¹ See note on Psalm lix. p. 396.

The XXIII.
Day.
Evening
Prayer.

Ps. cxxxv. 18.

7 They have hands, and handle not; feet have they, and walk not: neither speak they through their throat.

8 They that make them are like unto them: and so are all such as put their trust in them.

Isa. xli. 8.
Ps. cxxxv. 19—21.

9 But thou, house of Israel, trust thou in the Lord: he is their succour and defence.

10 Ye house of Aaron, put your trust in the Lord: he is their helper and defender.

11 Ye that fear the Lord, put your trust in the Lord: he is their helper and defender.

Isa. lv. 5.

12 The Lord hath been mindful of us, and he shall bless us: even he shall bless the house of Israel, he shall bless the house of Aaron.

13 He shall bless them that fear the Lord: both small and great.

Isa. xxvi. 15.

14 The Lord shall increase you more and more: you and your children.

Gen. xiv. 19.

15 Ye are the blessed of the Lord: who made heaven and earth.

16 All the whole heavens are the Lord's: the earth hath he given to the children of men.

Isa. xxxviii. 18.

17 The dead praise not thee, O Lord: neither all they that go down into silence.

Mic. vii. 18—20.

18 But we will praise the Lord: from this time forth for evermore. Praise the Lord.

THE CXVI PSALM.

Dilexi, quoniam.

The XXIV.
Day.
Morning
Prayer.
Churching of
Women.
Heb. vii. 25.

I AM well pleased: that the Lord hath heard the voice of my prayer; 2 That he hath inclined his ear unto me: therefore will I call upon him as long as I live.

Manus habent, et non palpabunt; pedes habent, et non ambulabunt: non clamabunt in gutture suo.

Similes illis fiant qui faciunt ea: et omnes qui confidunt in eis.

guttur suo neque enim spiritus in ore ipsorum

Domus Israël speravit in Domino: adjutor eorum et protector eorum est.

Domus Aaron speravit in Domino: adjutor eorum et protector eorum est.

Qui timent Dominum, speraverunt in Domino: adjutor eorum et protector eorum est.

Dominus memor fuit nostri: et benedixit nobis.

Benedixit domui Israël: benedixit domui Aaron.

Benedixit omnibus qui timent Dominum: pusillis cum majoribus.

Adjiciat Dominus super vos: super vos, et super filios vestros.

Benedicti vos a Domino: qui fecit cælum et terram.

Cælum cæli Domino: terram autem dedit filiis hominum.

Non mortui laudabunt te Domine: neque omnes qui descendunt in infernum.

Sed nos qui vivimus benedicimus Domino: ex hoc nunc et usque in sæculum.

PSALMUS CXIV.

DILEXI, quoniam exaudiet Dominus: vocem orationis meæ.

Quia inclinavit aurem suam mihi: et in diebus meis invocabo.

Monday Vespers. Vigils of the departed. exaudivit

thing yet to come than of assurance respecting a gain already acquired. The second verse points to the taunts with which the Jews mocked our Lord when upon the Cross, and to those with which the heathen long assailed the Church respecting her invisible God and Saviour. The blindness of those who reject Christ is also compared to the senselessness of the idols which they set up in His place; idols, at one time of material silver and gold, at another of the imagination and distorted reason, but all equally worthless as objects of worship and faith. The new Israel of Christ is bidden to stand firm against the shock of all such taunts and all such seductions, to look for the blessing of its Divine Head, and to be assured that though only a "little flock" they shall grow into a vast people, a living body spread over the

earth, which has become the heritage of the Son of Man, and singing Hallelujah to Him for evermore.

PSALM CXVI¹.—This and the last Psalm of the series are of a much more distinctly personal character than those which form the first half of the series, as if they were words spoken within the privacy of that inner fold of Apostles in which Christ was accustomed to expound privately the things which had been spoken to the people at large in parables, and as if the time of the Great Pass-

¹ This Psalm was associated with the Burial of the Dead as early as the time of St. Chrysostom.

The XXIV.
Day.
Morning
Prayer.

3 The snares of death compassed me round about; and the pains of hell gat hold upon me.

4 I shall find trouble and heaviness, and I will call upon the Name of the Lord: O Lord, I beseech thee, deliver my soul.

5 Gracious is the Lord, and righteous: yea, our God is merciful.

6 The Lord preserveth the simple: I was in misery, and he helped me.

Isa. xxvi. 3.
Matt. xi. 28-30.

7 Turn again then unto thy rest, O my soul: for the Lord hath rewarded thee.

Isa. xxv. 8.

8 And why? thou hast delivered my soul from death: mine eyes from tears, and my feet from falling.

9 I will walk before the Lord: in the land of the living.

2 Cor. iv. 13.
Rom. iii. 4.

10 I believed, and therefore will I speak; but I was sore troubled: I said in my haste, All men are liars.

1 Thess. iii. 9.

11 What reward shall I give unto the Lord: for all the benefits that he hath done unto me?

Luke xxii. 17.
Numb. xxviii. 7, 8.

12 I will receive the cup of salvation: and call upon the Name of the Lord.

13 I will pay my vows now in the presence of all his people: right dear in the sight of the Lord is the death of his saints.

Isa. xli. 8.
Phil. ii. 6, 7.

14 Behold, O Lord, how that I am thy servant: I am thy servant, and the son of thine handmaid; thou hast broken my bonds in sunder.

15 I will offer to thee the sacrifice of thanksgiving: and will call upon the Name of the Lord.

16 I will pay my vows unto the Lord in the sight of all his people: in the courts of the Lord's house, even in the midst of thee, O Jerusalem. Praise the Lord.

Circunderunt me dolores mortis: et pericula inferni invenerunt me.

Tribulationem et dolorem inveni: et Nomen Domini invocavi.

O Domine, libera animam meam; misericors Dominus, et justus: et Deus noster miseretur.

Custodiens parvulos Dominus: humiliatus sum, et liberavit me.

Convertere, anima mea, in requiem tuam: quia Dominus benefecit tibi.

Quia eripuit animam meam de morte, oculos meos a lachrymis: pedes meos a lapsu.

Placebo Domino: in regione vivorum.

PSALMUS CXV.

CREDIDI, propter quod locutus sum: ego autem humiliatus sum nimis.

Monday, Maundy
Thursd., Good
Friday, App.
and Evv.,
Many Martyrs,
All Saints,
Vespers.
excessu mentis
mea

Ego dixi in excessu meo: Omnis homo mendax.

Quid retribuam Domino: pro omnibus quæ retribuit mihi.

Calicem salutaris accipiam: et Nomen Domini invocabo.

Vota mea Domino reddam coram omni populo ejus: pretiosa in conspectu Domini mors sanctorum ejus.

nomen Domini in-
vocabo
Pretiosa in con-
spectu

O Domine, quia ego servus tuus: O Domine ego ego servus tuus, et filius ancillæ tuæ.

Dirupisti vincula mea: tibi sacrificabo hostiam laudis: et Nomen Domini invocabo.

Vota mea Domino reddam in conspectu omnis populi ejus: in atribus domus Domini, in medio tui Hierusalem.

laudis. Vota mea,
sc.

over was felt to be drawing nearer and nearer. The tone of this Psalm is like that of One already recovering from a great Agony, comforted and reassured by having been heard in His prayer which He had thrice uttered out of the midst of snares of death and the pains of hell through which He had passed. Further trouble and heaviness yet await Him, but His resignation is now complete, "not My will but Thine:" and His vision of future deliverance is clear. Thus we cannot fail to associate the "Cup of salvation" with that

of which He said, "If it be possible, remove this Cup from Me," and with His words to the sons of Zebedee, "Are ye able to drink of the Cup that I shall drink of?" That Cup is viewed, now, not as a cup of suffering, but as an Eucharistic Cup, "I will offer to Thee the sacrifice of thanksgiving;" and it is to be offered in the presence of all His people, *in facie Ecclesie*, as a Memorial of that Death of the King of Saints which is "right dear in the sight of the Lord," as a prevailing Intercession.

THE CXVII PSALM.

Laudate Dominum.

The XXIV.
Day.
Morning
Prayer.
Rom. xv. 11.
Luke i. 78, 79.

O PRAISE the Lord, all ye hea-
then : praise him, all ye nations.

2 For his merciful kindness is ever
more and more towards us : and the
truth of the Lord endureth for ever.
Praise the Lord.

THE CXVIII PSALM.

Confitemini Domino.

Easter Day,
Evensong.
2 Chron. v. 13.
vii. 3.
Ezra iii. 10, 11.

O GIVE thanks unto the Lord,
for he is gracious : because his
mercy endureth for ever.

2 Let Israel now confess, that he is
gracious : and that his mercy endureth
for ever.

3 Let the house of Aaron now con-
fess : that his mercy endureth for ever.

4 Yea, let them now that fear the
Lord confess : that his mercy endureth
for ever.

5 I called upon the Lord in trouble :
and the Lord heard me at large.

Zech. iii. 2.
Heb. xiii. 6.

6 The Lord is on my side : I will
not fear what man doeth unto me.

7 The Lord taketh my part with
them that help me : therefore shall I
see my desire upon mine enemies.

John ii. 24, 25.

8 It is better to trust in the Lord :
than to put any confidence in man.

9 It is better to trust in the Lord :
than to put any confidence in princes.

10 All nations compassed me round
about : but in the Name of the Lord
will I destroy them.

11 They kept me in on every side,
they kept me in, I say, on every side :
but in the Name of the Lord will I
destroy them.

Cf. Ps. lviii. 8.

12 They came about me like bees,
and are extinct even as the fire among
the thorns : for in the Name of the
Lord I will destroy them.

13 Thou hast thrust sore at me
that I might fall : but the Lord was
my help.

PSALMUS CXVI.

LAUDATE Dominum omnes Monday, General
Festival,
Vespers,
Christmas,
1st Vespers.
gentes : laudate eum omnes
populi :

Quoniam confirmata est super nos
misericordia ejus : et veritas Domini
manet in æternum.

PSALMUS CXVII.

CONFITEMINI Domino quoniam Sunday Prime.
bonus : quoniam in sæculum
misericordia ejus.

Dicat nunc Israël quoniam bonus :
quoniam in sæculum misericordia ejus.

Dicat nunc domus Aaron : quoniam quoniam bonus
quoniam
in sæculum misericordia ejus.

Dicant nunc qui timent Dominum : omnes qui
quoniam bonus
quoniam
quoniam in sæculum misericordia ejus.

De tribulatione invocavi Dominum :
et exaudivit me in latitudine Dominus.

Dominus mihi adjutor : non timebo
quid faciat mihi homo.

Dominus mihi adjutor : et ego despi- videbo
ciam inimicos meos.

Bonum est confidere in Domino :
quam confidere in homine.

Bonum est sperare in Domino :
quam sperare in principibus.

Omnes gentes circuierunt me : et in circumderunt
in nom. Domini
ultus, &c.
Nomine Domini quia ultus sum in
eos.

Circumdantes circumderunt me : et
in Nomine Domini quia ultus sum in Domini ultus
eos.

Circumderunt me sicut apes, et
exarserunt sicut ignis in spinis : et in
Nomine Domini quia ultus sum in eos. Domini vindica-
tor in eis

Impulsus eversus sum ut caderem : versatus sum
et Dominus suscepit me.

PSALM CXVII.—This expansion of the word Hallelujah is to be considered as a doxology uniting the 116th and 118th Psalms, calling upon all people to join with the "little flock" of the Saviour in praising the Lord for His merciful kindness and for the fulfilment of His covenant with mankind respecting their salvation.

PSALM CXVIII.—The first four verses of the last Psalm, of the series are a continuation of the strain taken up in the preceding Doxology : in the fifth verse the individual or personal Voice of Christ is again heard, and thenceforward to the end. That tone is a triumphant anticipation, throughout, of the Easter victory :

The XXIV. Day. Morning Prayer. Exod. xv. 2. Isa. xii. 2. Isa. xl. 1-11.	14 The Lord is my strength, and my song : and is become my salvation.	Fortitudo mea et laus mea Dominus : et factus est mihi in salutem.
	15 The voice of joy and health is in the dwellings of the righteous : the right hand of the Lord bringeth mighty things to pass.	Vox exultationis et salutis : in tabernaculis justorum.
Exod. xv. 6.	16 The right hand of the Lord hath the pre-eminence : the right hand of the Lord bringeth mighty things to pass.	Dextera Domini fecit virtutem, dextera Domini exaltavit me : dextera Domini fecit virtutem.
	17 I shall not die, but live : and declare the works of the Lord.	Non moriar, sed vivam : et narrabo opera Domini.
Heb. xii. 7.	18 The Lord hath chastened and corrected me : but he hath not given me over unto death.	Castigans castigavit me Dominus : et morti non tradidit me.
Ps. xxiv. 7-10. Isa. xxvi. 2.	19 Open me the gates of righteousness : that I may go into them, and give thanks unto the Lord.	Aperite mihi portas justitiæ, et ingressus in eas confitebor Domino : hæc porta Domini ; justi intrabunt in eam.
John x. 9.	20 This is the gate of the Lord : the righteous shall enter into it.	
	21 I will thank thee, for thou hast heard me : and art become my salvation.	Confitebor tibi, quoniam exaudisti me : et factus es mihi in salutem.
Matt. xxi. 42. Mark xii. 10. Luke xx. 17. Acts iv. 11. Eph. ii. 20. Isa. xxviii. 16. 1 Pet. ii. 7.	22 The same stone which the builders refused : is become the headstone in the corner.	Lapidem quem reprobaverunt ædificantes : hic factus est in caput anguli.
John viii. 56. 1 Cor. v. 7.	24 This is the day which the Lord hath made : we will rejoice and be glad in it.	Hæc est dies quam fecit Dominus : exultemus et lætemur in ea.
Nehem. i. 11.	25 Help me now, O Lord : O Lord, send us now prosperity.	O Domine, salvum me fac, O Domine, bene prosperare : benedictus qui venit in Nomine Domini.
Matt. xxi. 9. xxiii. 39.	26 Blessed be he that cometh in the Name of the Lord : we have wished you good luck, ye that are of the house of the Lord.	Benediximus vobis de domo Domini : Deus Dominus, et illuxit nobis.
John xiii. 46, 35, 36. i. 4, 5. iii. 19. viii. 12. xii. 32. 46.	27 God is the Lord who hath shewed us light : bind the sacrifice with cords, yea, even unto the horns of the altar.	Constituite diem solennem in condensis : usque ad cornu altaris.

and its climax is reached in the twenty-seventh verse, where the Lamb of God offers Himself willingly for the coming Sacrifice¹. A few days before the singing of the Great Hallelujah, the multitude had led Jesus into Jerusalem with the glad proclamation taken from the twenty-sixth verse of this Psalm. [Matt. xxi. 9.] When our Lord was taking His last farewell of the city He said "Ye shall not see Me henceforth, till ye shall say, Blessed is He that cometh in the Name of the Lord." [Matt. xxiii. 39.] His last words to the people at large were "Yet a little while is the Light with you. Walk while ye have the Light, lest darkness come upon you : for he that walketh in darkness knoweth not whither he goeth. While ye have light, believe in the Light, that ye may be the children of light." [John xii. 35, 36.] Thus are His

¹ Some modern critics read this verse as if "bind the sacrifice with cords" were a parenthesis, and the "light" a fire extending even to the horns of the altar. The association of the verses indicated in the above note may lead us to doubt the accuracy of such an interpretation.

"lifting up" [Ibid. 32], and His accustomed cry "I am come a Light into the world" [Ibid. 46], associated with the twenty-sixth and twenty-seventh verses of this Psalm, and the ancient words of Abraham were illustrated in their fulfilment, "My son, God will provide Himself a Lamb for a burnt offering." [Gen. xxii. 8.]

From the tenth to the thirteenth verses is expressed the suffering Saviour's prevision of the result of His work : in the seventh, eighth, and ninth, and nineteenth, the same prevision of a glorious Resurrection through which He Himself was to become eternally the Door whereby His flock should enter into life : and the twenty-fourth verse is a prophetic welcome of that Day of the Lord in which all mankind should keep a perpetual Easter of joy. And thus throughout are heard such words as those of the prophet, "In that day thou shalt say, O Lord, I will praise Thee : though Thou wast angry with me, Thine anger is turned away, and Thou comfortedst me. Behold, God is my salvation ; I will

The XXIV.
Day.
Morning
Prayer.

28 Thou art my God, and I will
thank thee : thou art my God, and I
will praise thee.

Ezra iii. 10, 11.

29 O give thanks unto the Lord,
for he is gracious : and his mercy
endureth for ever.

THE CXIX PSALM.

Beati immaculati.

Evening
Prayer.
Heb. ix. 14.
1 Pet. i. 19.
Cant. iv. 7.

BLESSED are those that are un-
defiled in the way : and walk in
the law of the Lord.

Eph. v. 27.
2 Pet. iii. 14.

2 Blessed are they that keep his
testimonies : and seek him with their
whole heart.

Luke ii. 52.
i. 6. 80.

3 For they who do no wickedness :
walk in his ways.

4 Thou hast charged : that we
shall diligently keep thy command-
ments.

5 O that my ways were made so
direct : that I might keep thy sta-
tutes.

1 John ii. 8.

6 So shall I not be confounded :
while I have respect unto all thy com-
mandments.

7 I will thank thee with an un-
feigned heart : when I shall have
learned the judgements of thy righte-
ousness:

8 I will keep thy ceremonies : O
forsake me not utterly.

In quo corriget.

2 Pet. i. 4.

WHEREWITHAL shall a young
man cleanse his way : even
by ruling himself after thy word.

John vi. 38.

10 With my whole heart have I
sought thee : O let me not go wrong
out of thy commandments.

Deus meus es tu, et confitebor tibi :
Deus meus es tu, et exaltabo te.

Confitebor tibi quoniam exaudisti tibi *Domine*
me : et factus es mihi in salutem.

Confitemini Domino quoniam bonus :
quoniam in sæculum misericordia ejus.

PSALMUS CXVIII.

[A. ALLELUIA. ALEPH EST DEUS.]

BEATI immaculati in via : qui am- Prime.
Commendation of
Souls.
bulant in lege Domini.

Beati qui scrutantur testimonia ejus :
in toto corde exquirunt eum.

Non enim qui operantur iniquitatem :
in viis ejus ambulaverunt.

Tu mandasti : mandata tua custo-
diri nimis.

Utinam dirigantur viæ meæ : ad
custodiendas justificationes tuas.

Tunc non confundar : cum per- respicio
spexero in omnibus mandatis tuis.

Confitebor tibi in directione cordis :
in eo quod didici judicia justitiæ tuæ.

Justificationes tuas custodiam : non
me derelinquas usquequaque.

[B. BETH EST FILIUS.]

In quo corrigit adolescentior viam Prime.
suam : in custodiendo sermones tuos.

In toto corde meo exquisivi te : ne
repellas me a mandatis tuis.

trust, and not be afraid : for the Lord JEHOVAH is my strength
and my song ; He also is become my salvation." [Isa. xii. 2.]
"O give thanks unto the Lord, for He is gracious, and His mercy
endureth for ever."

PSALM CXIX¹.

The characteristic feature of this Psalm is a pervading reference
to the will of God and the grace of obedience. It was noted by

¹ This is an "alphabet Psalm" of a peculiar character. Each division
is made of verses which begin with the same letter, the sections answering
to the verses of the other alphabet Psalms. The same arrangement is found
in the Book of Lamentations. In the earlier Vulgate, which is represented
(so far as it differs from the later) in the margin, the Hebrew division is
recognized as in our English Psalter. But in the Sarum Psalter, and in the
modern Vulgate, the Psalm is divided into sections of sixteen verses. The
bracketed titles of each section are from the ancient Vulgate, and are in-
serted in the text instead of the margin for convenience of arrangement.

the ancient Jewish commentators that every verse contains some
word associated with the spoken will of God : and the light of
Gospel truth leads clearly to the interpretation of all, or nearly
all, of these, in connexion with the Person of our Blessed Lord.
This is the more evident as in forty out of one hundred and
seventy-six such expressions, the actual title of the "WORD"
is used, by which the Second Person in the Blessed Trinity is
designated in the New Testament : while the remainder, such as
Law, Testimony, Commandment, Judgment, Way, Truth, are all
of a character that gives them a personal association with Him
Who declared "I am the Way, the Truth, and the Life," and
Whose declaration "I am the Light of the world," also exhibits
Him as being the Personal Manifestation of Divine Will and Law.

As, moreover, we know by later revelations that our Lord Jesus
is set forth to mankind as the highest standard of obedience and
holiness, so we hear, throughout this Psalm, the Voice of His

The XXIV.
Day.
*Evening
Prayer.*

11 Thy words have I hid within my heart : that I should not sin against thee.

In corde meo abscondi eloquia tua : ut non peccem tibi.

12 Blessed art thou, O Lord : O teach me thy statutes.

Benedictus es, Domine : doce me justificationes tuas.

John vii. 17.
ix. 31.

13 With my lips have I been telling : of all the judgements of thy mouth.

In labiis meis pronuntiavi : omnia judicia oris tui.

14 I have had as great delight in the way of thy testimonies : as in all manner of riches.

In via testimoniorum tuorum delectatus sum : sicut in omnibus divitiis.

John xvii. 14.

15 I will talk of thy commandments : and have respect unto thy ways.

In mandatis tuis exercebor : et considerabo vias tuas.

John iv. 34.
v. 20.

16 My delight shall be in thy statutes : and I will not forget thy word.

In justificationibus tuis meditabor : non obliviscar sermones tuos.

Retribue servo tuo.

O DO well unto thy servant : that I may live, and keep thy word.

[F. CAMEL EST CONSOLATIO.]

RETRIBUE servo tuo ; vivifica me : et custodiam sermones tuos.

18 Open thou mine eyes : that I may see the wondrous things of thy law.

Revela oculos meos : et considerabo mirabilia de lege tua.

John i. 11.
Heb. xi. 13.
Eph. ii. 19.

19 I am a stranger upon earth : O hide not thy commandments from me.

Incola ego sum in terra : non abscondas a me mandata tua.

20 My soul breaketh out for the very fervent desire : that it hath alway unto thy judgements.

Concupivit anima mea desiderare justificationes tuas : in omni tempore.

21 Thou hast rebuked the proud : and cursed are they that do err from thy commandments.

Increpasti superbos : maledicti qui declinant a mandatis tuis.

22 O turn from me shame and rebuke : for I have kept thy testimonies.

Aufer a me opprobrium et contemptum : quia testimonia tua exquisivi.

Matt. xxvi. 65.
xxvii. 1. 12.

23 Princes also did sit and speak against me : but thy servant is occupied in thy statutes.

Etenim sederunt principes, et adversum me loquebantur : servus autem tuus exercebatur in justificationibus tuis.

24 For thy testimonies are my delight : and my counsellors.

Nam et testimonia tua meditatio mea est : et consilium meum justificationes tuæ.

Adhæsit pavimento.

Matt. xxvi. 38.

MY soul cleaveth to the dust : O quicken thou me, according to thy word.

[Δ. DELETH EST JUDICIUM.]

Adhæsit pavimento anima mea : vivifica me secundum verbum tuum.

Human Nature, speaking as the Representative of God's children : and speaking in such tones as to make Himself, in His perfect obedience, the One Example for us, according to our ability, to follow. "Learn of Me, for I am meek, and lowly of heart."

And, lastly, as our Lord's Person is the Sacramental Fountain of all holiness, so incorporation with the WORD is mystically set forth in every portion of this Psalm as the means by which holiness is to be attained. "I am the Vine, ye are the branches : he that abideth in Me, and I in him, the same bringeth forth much

fruit : for severed from Me ye can do nothing." [John xv. 5, marg.]

The whole Psalm is, therefore, to be interpreted on one principle, as setting forth the blessedness of conformity to the example of our Lord Jesus Christ by the transformation of our own wills through sacramental union with Him, THE WORD. In many parts there seems to be little other coherence between the separate sections, or even the separate verses of a section ; but this pervading principle is a bond of unity which makes it impossible

The XXIV.
Day.
Evening
Prayer.

26 I have acknowledged my ways,
and thou heardest me : O teach me
thy statutes.

27 Make me to understand the way
of thy commandments : and so shall I
talk of thy wondrous works.

Luke xxii. 43.

28 My soul melteth away for very
heaviness : comfort thou me according
unto thy word.

29 Take from me the way of lying :
and cause thou me to make much of
thy law.

John xvii. 4.

30 I have chosen the way of truth :
and thy judgements have I laid before
me.

31 I have stuck unto thy testi-
monies : O Lord, confound me not.

32 I will run the way of thy com-
mandments : when thou hast set my
heart at liberty.

Legem pone.

The XXV. Day.
Morning
Prayer.

TEACH me, O Lord, the way of
thy statutes : and I shall keep it
unto the end.

34 Give me understanding, and I
shall keep thy law : yea, I shall keep
it with my whole heart.

Rom. vii. 22.

35 Make me to go in the path of
thy commandments : for therein is my
desire.

36 Incline my heart unto thy tes-
timonies : and not to covetousness.

37 O turn away mine eyes, lest
they behold vanity : and quicken thou
me in thy way.

38 O stablish thy word in thy ser-
vant : that I may fear thee.

Ps lxi. 20.

39 Take away the rebuke that I
am afraid of : for thy judgements are
good.

40 Behold, my delight is in thy
commandments : O quicken me in thy
righteousness.

Et veniat super me.

LET thy loving mercy come also
unto me, O Lord : even thy sal-
vation, according unto thy word.

Vias meas enuntiavi, et exaudisti
me : doce me justificationes tuas.

Viam justificationum tuarum in- *insinua me*
strue me : et exercebor in mirabilibus
tuis.

Dormitavit anima mea præ tædio :
confirma me in verbis tuis.

Viam iniquitatis amove a me : et de
lege tua miserere mei.

Viam veritatis elegi : judicia tua non
sum oblitus.

Adhæsi testimoniis tuis, Domine :
noli me confundere.

Viam mandatorum tuorum cucurri :
cum dilatasti cor meum. *dilatatus*

[E. ELI EST VIA SALUTIS.]

LEGEM pone mihi, Domine, viam *Tierce.*
justificationum tuarum : et ex-
quiram eam semper.

Da mihi intellectum, et scrutabor
legem tuam : et custodiam illam in
toto corde meo.

Deduc me in semita mandatorum
tuorum : quia ipsam volui.

Inclina cor meum in testimonia tua :
et non in avaritiam.

Averte oculos meos ne videant vani-
tatem : in via tua vivifica me.

Statue servo tuo eloquium tuum :
in timore tuo.

Amputa opprobrium meum quod
suspiciatus sum : quia judicia tua ju-
cunda.

Ecce concupivi mandata tua : in
æquitate tua vivifica me.

[Z. VALI EST NON HABET.]

Et veniat super me misericordia tua, *Tierce.*
Domine : salutare tuum secundum
eloquium tuum.

to consider the Psalm as a fortuitous collection of pious thoughts, as some have supposed. At the same time there does not seem to be any formal division of the Psalm into separate subjects, and it must be taken as a continuous elaboration of the one idea indicated; the turning about of a diamond whose light is refracted through many facets, and whose brilliant beauty is discerned from whatever point of view it is looked at.

This characteristic of the 119th Psalm seems to make it unnecessary to give any exposition of it in further detail. It is sufficient to offer the suggestion that the principle indicated should be carefully kept in view in the liturgical use of the Psalm, and that a mind imbued with pervading reverence for our Lord's Person and Example can hardly apply that principle in too minute detail.

The XXV. Day.
Morning
Prayer.
John xviii. 36.

42 So shall I make answer unto my blasphemers : for my trust is in thy word.

43 O take not the word of thy truth utterly out of my mouth : for my hope is in thy judgements.

44 So shall I alway keep thy law : yea, for ever and ever.

45 And I will walk at liberty : for I seek thy commandments.

Luke xxii. 69.
John xviii. 37.

46 I will speak of thy testimonies also, even before kings : and will not be ashamed.

47 And my delight shall be in thy commandments : which I have loved.

Heb. xii. 12.

48 My hands also will I lift up unto thy commandments, which I have loved : and my study shall be in thy statutes.

Memor esto servi tui.

O THINK upon thy servant, as concerning thy word : wherein thou hast caused me to put my trust.

John i. 4.

50 The same is my comfort in my trouble : for thy word hath quickened me.

1 Cor. ii. 14.

51 The proud have had me exceedingly in derision : yet have I not shrunk from thy law.

52 For I remembered thine everlasting judgements, O Lord : and received comfort.

53 I am horribly afraid : for the ungodly that forsake thy law.

2 Cor. v. 1.

54 Thy statutes have been my songs : in the house of my pilgrimage.

Job xxxv. 10.

55 I have thought upon thy Name, O Lord, in the night-season : and have kept thy law.

56 This I had : because I kept thy commandments.

Portio mea, Domine.

THOU art my portion, O Lord : I have promised to keep thy law.

Matt. xxvi. 42.

58 I made my humble petition in thy presence with my whole heart : O be merciful unto me, according to thy word.

59 I called mine own ways to remembrance : and turned my feet unto thy testimonies.

Et respondebo exprobrantibus mihi verbum : quia speravi in sermonibus tuis.

Et ne auferas de ore meo verbum veritatis usquequaque : quia in judiciis tuis supersperavi.

speravi

Et custodiam legem tuam semper : in sæculum et in sæculum sæculi.

in æternum et in sæc.

Et ambulabam in latitudine : quia mandata tua exquisivi.

Et loquebar in testimoniis tuis in conspectu regum : et non confundebar.

Et meditabar in mandatis tuis : quæ dilexi.

meditabor . . . dilexi nimis

Et levavi manus meas ad mandata tua quæ dilexi : et exercebor in justificationibus tuis.

dilexi vehementer

[H. NAU EST PASSIO.]

MEMOR esto verbi tui servo tuo : Tierce. in quo mihi spem dedisti.

Hæc me consolata est in humilitate mea : quia eloquium tuum vivificavit me.

Superbi inique agebant usquequaque : a lege autem tua non declinavi.

Memor fui judiciorum tuorum a sæculo, Domine : et consolatus sum.

Defectio tenuit me : pro peccatoribus derelinquentibus legem tuam.

Defectio animi . . . præ

Cantabiles mihi erant justificationes tuæ : in loco peregrinationis meæ.

incolatus mei

Memor fui nocte Nominis tui, Domine : et custodivi legem tuam.

Hæc facta est mihi : quia justificationes tuas exquisivi.

[Θ. ZAE EST ELEMENTUM MUNDI.]

Portio mea, Domine : dixi custodire legem tuam.

Tierce.

Deprecatus sum faciem tuam in toto corde meo : miserere mei secundum eloquium tuum.

Cogitavi vias meas et converti pedes meos : in testimonia tua.

The XXV. Day.
Morning
Prayer.
Cant. i. 4.
Luke ii. 21.

60 I made haste, and prolonged not the time : to keep thy commandments.

61 The congregations of the ungodly have robbed me : but I have not forgotten thy law.

Mark xvi. 2.

62 At midnight I will rise to give thanks unto thee : because of thy righteous judgements.

John xv. 14.
Heb. ii. 11.

63 I am a companion of all them that fear thee : and keep thy commandments.

64 The earth, O Lord, is full of thy mercy : O teach me thy statutes.

Bonitatem fecisti:

O LORD, thou hast dealt graciously with thy servant : according unto thy word.

66 O learn me true understanding and knowledge : for I have believed thy commandments.

67 Before I was troubled, I went wrong : but now have I kept thy word.

68 Thou art good and gracious : O teach me thy statutes.

Job xiii. 14.

69 The proud have imagined a lie against me : but I will keep thy commandments with my whole heart.

70 Their heart is as fat as brawn : but my delight hath been in thy law.

1 Pet. iv. 1.

71 It is good for me that I have been in trouble : that I may learn thy statutes.

Prov. iii. 14.

72 The law of thy mouth is dearer unto me : than thousands of gold and silver.

Manus tuæ fecerunt me.

Evening
Prayer.
Job x. 8.

THY hands have made me and fashioned me : O give me understanding, that I may learn thy commandments.

74 They that fear thee will be glad when they see me : because I have put my trust in thy word.

Deut. xxxii. 4.
1 Cor. x. 13.
Heb. xii. 6.

75 I know, O Lord, that thy judgements are right : and that thou of very faithfulness hast caused me to be troubled.

76 O let thy merciful kindness be my comfort : according to thy word unto thy servant.

Paratus sum, et non sum turbatus : ut custodiam mandata tua.

Funes peccatorum circumplexi sunt me : et legem tuam non sum oblitus.

Media nocte surgebam ad confitendum tibi : super judicia justifica- *justitia tue* tionis tuæ.

Particeps ego sum omnium timendum te : et custodientium mandata tua.

Misericordia tua, Domine, plena est terra : justificationes tuas doce me.

[I. ETA EST VITA.]

BONITATEM fecisti cum servo *Tierce.* tuo, Domine : secundum verbum tuum.

Bonitatem et disciplinam et scientiam doce me : quia mandatis tuis credidi.

Priusquam humiliarer ego deliqui : propterea eloquium tuum custodivi.

Bonus es tu : et in bonitate tua doce me justificationes tuas.

Multiplicata est super me iniquitas superbiorum : ego autem in toto corde meo scrutabor mandata tua.

Coagulatum est sicut lac cor eorum : ego vero legem tuam meditatus sum.

Bonum mihi quia humiliasti me : ut discam justificationes tuas.

Bonum mihi lex oris tui : super millia auri et argenti.

[K. THET EST BONUM.]

Manus tuæ fecerunt me et plasma- *Tierce.* verunt me : da mihi intellectum, ut discam mandata tua.

Qui timent te videbunt me et lætabuntur : quia in verba tua super speravi.

Cognovi, Domine, quia æquitas judicia tua : et in veritate tua humiliasti me.

Fiat misericordia tua ut consoletur *Fiat nuno* me : secundum eloquium tuum servo tuo.

The XXV. Day.
Evening
Prayer.

77 O let thy loving mercies come unto me, that I may live : for thy law is my delight.

78 Let the proud be confounded, for they go wickedly about to destroy me : but I will be occupied in thy commandments.

79 Let such as fear thee, and have known thy testimonies : be turned unto me.

80 O let my heart be sound in thy statutes : that I be not ashamed.

Defecit anima mea.

Luke ii. 29.

MY soul hath longed for thy salvation : and I have a good hope because of thy word.

82 Mine eyes long sore for thy word : saying, O when wilt thou comfort me ?

83 For I am become like a bottle in the smoke : yet do I not forget thy statutes.

Rev. vi. 9.

84 How many are the days of thy servant : when wilt thou be avenged of them that persecute me ?

Gen. xxxvii. 20.
24.

85 The proud have digged pits for me : which are not after thy law.

86 All thy commandments are true : they persecute me falsely ; O be thou my help.

87 They had almost made an end of me upon earth : but I forsook not thy commandments.

88 O quicken me after thy loving-kindness : and so shall I keep the testimonies of thy mouth.

In æternum, Domine.

Isa. lx. 8.

OLORD, thy word : endureth for ever in heaven.

90 Thy truth also remaineth from one generation to another : thou hast laid the foundation of the earth, and it abideth.

91 They continue this day according to thine ordinance : for all things serve thee.

92 If my delight had not been in thy law : I should have perished in my trouble.

93 I will never forget thy commandments : for with them thou hast quickened me.

Veniant mihi miserationes tuæ et vivam : quia lex tua meditatio mea est.

Confundantur superbi, quia injuste iniquitatem fecerunt in me : ego autem exercebor in mandatis tuis.

Convertantur mihi timentes te : et qui noverunt testimonia tua.

Fiat cor meum immaculatum in justificationibus tuis : ut non confundar.

[A. JUTH EST JESUS CHRISTUS DEUS.]

DEFECIT in salutare tuum anima mea : et in verbum tuum desperavi.

Defecerunt oculi mei in eloquium tuum : dicentes, Quando consolaberis me ?

Quia factus sum sicut uter in pruina : justificationes tuas non sum oblitus.

Quot sunt dies servi tui : quando facies de persequentibus me judicium ?

Narraverunt mihi iniqui fabulationes : sed non ut lex tua.

Omnia mandata tua veritas : iniqui persecuti sunt me, adjuva me.

Paulominus consummaverunt me in terra : ego autem non dereliqui mandata tua.

Secundum misericordiam tuam vivifica me : et custodiam testimonia oris tui.

[M. TAP EST FRUCTUS MANUUM.]

In æternum, Domine : verbum tuum permanet in cælo.

In generatione et generationem veritas tua : fundasti terram et permanet.

Ordinatione tua perseverat dies : quoniam omnia serviunt tibi.

Nisi quod lex tua meditatio mea est : tunc forte periissem in humilitate mea.

In æternum non obliviscar justificationes tuas : quia in ipsis vivificasti me.

The XXV. Day.
Evening
Prayer.
John xvii. 10, 11.

94 I am thine, O save me : for I have sought thy commandments.

95 The ungodly laid wait for me to destroy me : but I will consider thy testimonies.

1 Pet. i. 24, 25.

96 I see that all things come to an end : but thy commandment is exceeding broad.

Quomodo dilexi.

LORD, what love have I unto thy law : all the day long is my study in it.

98 Thou through thy commandments hast made me wiser than mine enemies : for they are ever with me.

Luke ii. 46, 47.

99 I have more understanding than my teachers : for thy testimonies are my study.

100 I am wiser than the aged : because I keep thy commandments.

101 I have refrained my feet from every evil way : that I may keep thy word.

102 I have not shrunk from thy judgements : for thou teachest me.

Rev. x. 9, 10.

103 O how sweet are thy words unto my throat : yea, sweeter than honey unto my mouth.

104 Through thy commandments I get understanding : therefore I hate all evil ways.

Lucerna pedibus meis.

The XXVI.
Day.
Morning
Prayer.
John i. 9.
viii. 12.
Prov. vi. 23.

THY word is a lantern unto my feet : and a light unto my paths.

106 I have sworn, and am stedfastly purposed : to keep thy righteous judgements.

107 I am troubled, above measure : quicken me, O Lord, according to thy word.

108 Let the free-will offerings of my mouth please thee, O Lord : and teach me thy judgements.

1 Sam. xix. 5.
Job xlii. 14.
Acts xx. 23.

109 My soul is alway in my hand : yet do I not forget thy law.

110 The ungodly have laid a snare for me : but yet I swerved not from thy commandments.

111 Thy testimonies have I claimed as mine heritage for ever : and why? they are the very joy of my heart.

Tuus sum ego, salvum me fac : quoniam justificationes tuas exquisivi.

Me expectaverunt peccatores ut perderent me : testimonia tua intellexi.

Omnis consummationis vidi finem : latum mandatum tuum nimis.

[N. LAB EST DOCTRINA.]

QUOMODO dilexi legem tuam, *Sexts.*
Domine : tota die meditatio mea est.

Super inimicos meos prudentem me fecisti mandato tuo : quia in æternum mihi est.

Super omnes docentes me intellexi : quia testimonia tua meditatio mea est.

Super senes intellexi : quia mandata tua quæsivi.

Ab omni via mala prohibui pedes meos : ut custodiam verba tua.

A judiciis tuis non declinavi : quia tu legem posuisti mihi.

Quam dulcia faucibus meis eloquia tua : super mel ori meo? *mel et favum*

A mandatis tuis intellexi : propterea odivi omnem viam iniquitatis. *odio habui . . iniquitatis quia tu legem posuisti mihi*

[E. MEM EST MEDULLA.]

Lucerna pedibus meis verbum tuum : *Sexts.*
et lumen semitis meis.

Juravi et statui : custodire judicia justitiæ tuæ.

Humiliatus sum usquequaque, Domine : vivifica me secundum verbum tuum.

Voluntaria oris mei beneplacita fac, Domine : et judicia tua doce me.

Anima mea in manibus meis semper : et legem tuam non sum oblitus. *manibus tuis*

Posuerunt peccatores laqueum mihi : et de mandatis tuis non erravi.

Hæreditate acquisivi testimonia tua in æternum : quia exsultatio cordis mei sunt.

The XXVI.
Day.
Morning
Prayer.
1 Pet. i. 9.

112 I have applied my heart to fulfil thy statutes alway : even unto the end.

Iniquos odio habui.

Ecc. vii. 29.
James i. 8.

I HATE them that imagine evil things : but thy law do I love.

114 Thou art my defence and shield : and my trust is in thy word.

115 Away from me, ye wicked : I will keep the commandments of my God.

116 O stablish me according to thy word, that I may live : and let me not be disappointed of my hope.

117 Hold thou me up, and I shall be safe : yea, my delight shall be ever in thy statutes.

118 Thou hast trodden down all them that depart from thy statutes : for they imagine but deceit.

Isa. i. 25.
Ezek. xxii. 17—
22.
Mal. iii. 3.

119 Thou puttest away all the ungodly of the earth like dross : therefore I love thy testimonies.

Job iv. 14.

120 My flesh trembleth for fear of thee : and I am afraid of thy judgments.

Feci iudicium.

Isa. xxxviii. 14.

I DEAL with the thing that is lawful and right : O give me not over unto mine oppressors.

122 Make thou thy servant to delight in that which is good : that the proud do me no wrong¹.

Heb. ii. 3.

123 Mine eyes are wasted away with looking for thy health : and for the word of thy righteousness.

124 O deal with thy servant according unto thy loving mercy : and teach me thy statutes.

Phil. ii. 7.

125 I am thy servant, O grant me understanding : that I may know thy testimonies.

126 It is time for thee, Lord, to lay to thine hand : for they have destroyed thy law.

127 For I love thy commandments : above gold and precious stone.

128 Therefore hold I straight all thy commandments : and all false ways I utterly abhor.

Inclinavi cor meum ad faciendas justificationes tuas in æternum : propter retributionem.

[O. NUN EST MENS.]

INIQUOS odio habui : et legem sextæ tuam dilexi.

Adjutor et susceptor meus es tu : et in verbum tuum supersperavi. *speravi*

Declinate a me maligni : et scrutabor mandata Dei mei.

Suscipe me secundum eloquium tuum, et vivam : et non confundas me ab expectatione mea.

Adjuva me, et salvus ero : et meditabor in justificationibus tuis semper.

Sprevisti omnes discedentes a iudiciis tuis : quia injusta cogitatio eorum.

Prævaricantes reputavi omnes peccatores terræ : ideo dilexi testimonia tua.

Confige timore tuo carnes meas : et *Infige a timore* iudiciis enim tuis timui.

[II. SAMECH RESUPINATIO SIVE
REQUIES.]

Feci iudicium et justitiam : non tradas me calumniantibus me. *Sextæ. persequentibus me*

Suscipe servum tuum in bonum : *Elege servum* non calumnientur me superbi.

Oculi mei defecerunt in salutare tuum : et in eloquium justitiæ tuæ.

Fac cum servo tuo secundum misericordiam tuam : et justificationes tuas doce me.

Servus tuus sum ego : da mihi intellectum ut sciam testimonia tua.

Tempus faciendi, Domine : dissipaverunt legem tuam. *iniqui legem*

Ideo dilexi mandata tua : super aurum et topazion.

Propterea ad omnia mandata tua dirigebar : omnem viam iniquam odio habui.

¹ The ancient Jewish interpreters noted this verse as the only one which does not contain "thy word" or an equivalent expression.

Mirabilia.

The XXVI.
Day.
Morning
Prayer.

John i. 5. 9.
1 John i. 7.

THY testimonies are wonderful : therefore doth my soul keep them.

130 When thy word goeth forth : it giveth light, and understanding unto the simple.

131 I opened my mouth, and drew in my breath : for my delight was in thy commandments.

132 O look thou upon me, and be merciful unto me : as thou usest to do unto those that love thy Name.

133 Order my steps in thy word : and so shall no wickedness have dominion over me.

134 O deliver me from the wrongful dealings of men : and so shall I keep thy commandments.

135 Shew the light of thy countenance upon thy servant : and teach me thy statutes.

136 Mine eyes gush out with water : because men keep not thy law.

Jer. ix. 1.
xiii. 17.
Lam. i. 16.
John xi. 35.
Luke xix. 41.

Justus es, Domine.

Rev. xvi. 5.

RIGHTEOUS art thou, O Lord : and true is thy judgement.

138 The testimonies that thou hast commanded : are exceeding righteous and true.

John ii. 17.

139 My zeal hath even consumed me : because mine enemies have forgotten thy words.

140 Thy word is tried to the uttermost : and thy servant loveth it.

Isa. lx. 22.
Phil. ii. 7.

141 I am small, and of no reputation : yet do I not forget thy commandments.

142 Thy righteousness is an everlasting righteousness : and thy law is the truth.

143 The righteousness of thy testimonies is everlasting : O grant me understanding, and I shall live.

144 Trouble and heaviness have taken hold upon me : yet is my delight in thy commandments.

Clamavi in toto corde meo.

Evening
Prayer

I CALL with my whole heart : hear me, O Lord, I will keep thy statutes.

[P. ENA EST OCULUS.]

MIRABILIA testimonia tua, Domine : ideo scrutata est anima mea.

Declaratio sermonum tuorum illuminat : et intellectum dat parvulis.

Os meum aperui, et attraxi spiritum : quia mandata tua desiderabam.

Aspice in me et miserere mei : secundum judicium diligentium Nomen tuum.

Gressus meos dirige secundum eloquium tuum : ut non dominetur mei omnis injustitia.

Redime me a calumniis hominum : ut custodiam mandata tua.

Faciem tuam illumina super servum tuum : et doce me justificationes tuas.

Exitus aquarum deduxerunt oculi mei : quia non custodierunt legem tuam. *transierunt*

[Σ. COPH EST VOX.]

Justus es, Domine : et rectum judicium tuum.

Mandasti justitiam testimonia tua : et veritatem tuam nimis.

Tabescere me fecit zelus meus : quia oblitus sunt verba tua inimici mei. *zelus domus tua*

Ignitum eloquium tuum vehementer : et servus tuus dilexit illud.

Adolescentulus sum ego, et contemptus : justificationes tuas non sum oblitus.

Justitia tua justitia in æternum : et lex tua veritas.

Tribulatio et angustia invenerunt me : mandata tua meditatio mea est. *mandata autem*

Æquitas testimonia tua in æternum : intellectum da mihi et vivam.

[T. RES EST PRINCIPIUM.]

CLAMAVI in toto corde ; exaudi me, Domine : justificationes tuas requiram. *Nones.*

- The XXVI.
Day.
*Evening
Prayer.*
- 146 Yea, even unto thee do I call :
help me, and I shall keep thy testi-
monies.
- Mark i. 35.
- 147 Early in the morning do I cry
unto thee : for in thy word is my
trust.
- Lam. ii. 19.
- 148 Mine eyes prevent the night-
watches : that I might be occupied
in thy words.
- 149 Hear my voice, O Lord, ac-
cording unto thy loving-kindness :
quicken me according as thou art
wont.
- Zech. iii. 1, 2.
- 150 They draw nigh that of malice
persecute me : and are far from thy
law.
- 151 Be thou nigh at hand, O Lord :
for all thy commandments are true.
- 152 As concerning thy testimonies,
I have known long since : that thou
hast grounded them for ever.
- Vide humilitatem.*
- Ps. xxxv. 1, 24.
- O** CONSIDER mine adversity,
and deliver me : for I do not
forget thy law.
- 154 Avenge thou my cause, and
deliver me : quicken me according to
thy word.
- 155 Health is far from the un-
godly : for they regard not thy
statutes.
- 156 Great is thy mercy, O Lord :
quicken me, as thou art wont.
- Luke xxiii. 1.
- 157 Many there are that trouble
me and persecute me : yet do I not
swerve from thy testimonies.
- Luke xxiii. 28.
Matt. xxiii. 37.
- 158 It grieveth me when I see the
transgressors : because they keep not
thy law.
- 159 Consider, O Lord, how I love
thy commandments : O quicken me,
according to thy loving-kindness.
- 160 Thy word is true from ever-
lasting : all the judgements of thy
righteousness endure for evermore.
- Principes persecuti sunt.*
- Dan. vi. 4.
- P**RINCIPES have persecuted me
without a cause : but my heart
standeth in awe of thy word.
- 162 I am as glad of thy word : as
one that findeth great spoils.
- Clamavi ad te ; salvum me fac : ut
custodiam mandata tua.
- Præveni in maturitate, et clamavi :
quia in verba tua supersperavi. in verbo tuo
speravi
- Prævenerunt oculi mei ad te di- Præveniunt
luculo : ut meditarer eloquia tua.
- Vocem meam audi secundum mise-
ricordiam tuam, Domine : et secun-
dum judicium tuum vivifica me.
- Appropinquerunt persequentes me Adpropinquerunt
iniqui
iniquitati : a lege autem tua longe
facti sunt.
- Prope es tu, Domine : et omnes viæ omnia mandata
tua
tuæ veritas.
- Initio cognovi de testimoniis tuis :
quia in æternum fundasti ea.
- [Y. SEN EST VLE RECTÆ.]
- Vide humilitatem meam et eripe me : Nones.
quia legem tuam non sum oblitus.
- Judica judicium meum et redime
me : propter eloquium tuum vivifica
me.
- Longe a peccatoribus salus : quia
justificationes tuas non exquisierunt.
- Misericordiæ tuæ multæ, Domine : Miserationes . .
multæ nimis
secundum judicium tuum vivifica me.
- Multi qui persequuntur me et tri-
bulant me : a testimoniis tuis non
declinavi.
- Vidi prævaricantes, et tabescebam : non servantes
pactum
quia eloquia tua non custodierunt.
- Vide quoniam mandata tua dilexi,
Domine : in misericordia tua vivifica
me.
- Principium verborum tuorum veri-
tas : in æternum omnia judicia justitiæ
tuæ.
- [Φ TAU. EST MANSUETUS.]
- P**RINCIPES persecuti sunt me Nones.
gratis : et a verbis tuis formi-
davit cor meum.
- Lætabor ego super eloquia tua : sicut
qui invenit spolia multa.

The XXVI.
Day
Evening
Prayer.

163 As for lies, I hate and abhor them : but thy law do I love.

164 Seven times a day do I praise thee : because of thy righteous judgements.

Matt. xxvi. 63.

165 Great is the peace that they have who love thy law : and they are not offended at it.

166 Lord, I have lookéd for thy saving health : and, doné after thy commandments.

167 My soul hath kept thy testimonies : and loved them exceedingly.

168 I have kept thy commandments and testimonies : for all my ways are before thee.

Appropinquet deprecatio.

LET my complaint come before thee, O Lord : give me understanding, according to thy word.

170 Let my supplication come before thee : deliver me, according to thy word.

171 My lips shall speak of thy praise : when thou hast taught me thy statutes.

172 Yea, my tongue shall sing of thy word : for all thy commandments are righteous.

173 Let thine hand help me : for I have chosen thy commandments.

174 I have longed for thy saving health, O Lord : and in thy law is my delight.

175 O let my soul live, and it shall praise thee : and thy judgements shall help me.

Isa. liii. 6.
Jer. l. 6.
Luke xv. 6.
Ezek. xxxiv. 12.

176 I have gone astray like a sheep that is lost : O seek thy servant, for I do not forget thy commandments.

THE CXX PSALM.

Ad Dominum.

The XXVII.
Day.
Morning
Prayer.
A Gradual Psalm.

WHEN I was in trouble I called upon the Lord : and he heard me.

2. Deliver my soul, O Lord, from lying lips : and from a deceitful tongue.

Iniquitatem odio habui et abominatus sum : legem autem tuam dilexi.

Septies in die laudem dixi tibi : super judicia justitiæ tuæ.

Pax multa diligentibus legem tuam : *nomen tuum* et non est illis scandalum. *in illis*

* Expectabam salutare tuum, Domine : et mandata tua dilexi.

Custodivit anima mea testimonia tua : et dilexit ea vehementer.

Servavi mandata tua et testimonia tua : quia omnes viæ meæ in conspectu tuo.

tuo Domine

[X. ψ. w.]

Appropinquet deprecatio mea in conspectu tuo, Domine : juxta eloquium tuum da mihi intellectum.

Nones.
Adpropinquet oratio mea . . secundum eloq.

Intret postulatio mea in conspectu tuo : secundum eloquium tuum eripe me.

conspectu tuo Domine

Erucebant labia mea hymnum : cum docueris me justificationes tuas.

Pronuntiabit lingua mea eloquium tuum : quia omnia mandata tua æquitas.

Fiat manus tua ut salvet me : quoniam mandata tua elegi.

salvum me faciat

Concupivi salutare tuum, Domine : et lex tua meditatio mea est.

Vivet anima mea et laudabit te : et judicia tua adjuvabunt me.

Erravi sicut ovis quæ periit : quære servum tuum, quia mandata tua non sum oblitus.

perierat require . . tuum Domine . .

PSALMUS CXIX.

AD Dominum cum tribularer clamavi : et exaudivit me.

Mond., Maundy Thursday, Good Friday, Vespers.

Domine, libera animam meam a labiis iniquis : et a lingua dolosa.

Commendation of Souls. Vigils of the departed.

THE PSALMS OF DEGREES.

CXX—CXXXIV.

These fifteen Psalms have been so called from very distant times, perhaps from the time when they were originally composed. They have also been named "Psalmi communes" and "Psalmi penitentes,"

but these names have been less generally recognized than the other.

Several explanations have been given of the title "Songs of Degrees." Some have supposed that it indicated Psalms which were to be sung by the Levites with a high voice [2 Chron. xx. 19]; others that they were Psalms of special excellency, as persons are sometimes said to be of "high degree" [1 Chron. xvii.

The XXVII.
Day.
Morning
Prayer.
Luke xvi. 24.
Isa. xx. 17.

3 What reward shall be given or done unto thee, thou false tongue : even mighty and sharp arrows, with hot burning coals.

Gen. xxv. 13.
Isa. xlii. 11.
Matt. xvii. 17.

4 Wo is me, that I am constrained to dwell with Mesech : and to have my habitation among the tents of Kedar.

5 My soul hath long dwelt among them : that are enemies unto peace.

Isa. ix. 6.
John xiv. 27.
Isa. lix. 8.

6 I labour for peace, but when I speak unto them thereof : they make them ready to battle.

THE CXXI PSALM.

Levavi oculos.

A Gradual Psalm.
Ps. lxxxvii. 1.
Rev. xxi. 10.

I WILL lift up mine eyes unto the hills : from whence cometh my help.

2 My help cometh even from the Lord : who hath made heaven and earth.

Isa. v. 27.
Matt. xvi. 18.

3 He will not suffer thy foot to be moved : and he that keepeth thee will not sleep.

4 Behold, he that keepeth Israel : shall neither slumber nor sleep.

Isa. xxv. 4.

5 The Lord himself is thy keeper : the Lord is thy defence upon thy right hand ;

Quid detur tibi, aut quid apponatur tibi : ad linguam dolosam ?

a lingua dolosa

Sagittæ potentis acutæ : cum car- bonibus desolatoriis.

Heu mihi, quia incolatus meus prolongatus est ; habitavi cum habitantibus Cedar : multum incola fuit anima mea.

Cum his qui oderunt pacem eram pacificus : cum loquebar illis, impugnantabant me gratis.

PSALMUS CXX.

Levavi oculos meos in montes : unde veniet auxilium mihi.

Monday Vespera.
Vigils of the departed.
Purification of Women.

Auxilium meum a Domino : qui fecit cœlum et terram.

Non det in commotionem pedem tuum : neque dormitet qui custodit te.

neque obdormiet qui custodit te

Ecce non dormitabit neque dormiet : qui custodit Israël.

neque obdormiet

Dominus custodit te, Dominus protectio tua : super manum dexteram tuam.

17]; others again that they were Psalms composed to be sung at the "going up" of the banished tribes from Babylon to Judæa ; others that they were intended to be used by the people when "going up" to the feasts at Jerusalem. The most generally received explanation of the title is, however, that it marks processional Psalms which were sung during the ascent of the fifteen steps which led up to the Temple. [Cf. Ezek. xl. 22—34.] The first of these Psalms is entitled in the Chaldee "A Song for the goings up out of the deep," a superscription which is consistent with either of the two latter theories. They were probably written by David as part of that preparation which he made for the building of the Temple, and for the Divine Service to be carried on there : and although he himself was not permitted to lay a single stone, he thus in prophetic vision beheld the choirs of the House of God going up in procession to their work of praise. All of them bear the appearance of being written originally for use in the Temple Service, containing as they do such frequent references to Zion and Jerusalem, the Temple of the Lord, and the habitation of the mighty God of Jacob, references which, in a Christian sense, must be understood to apply to the Church of Christ. In that sense we may thus take the "Songs of Degrees" as hymns relating to the progress of Christ's Mystical Body

through the successive stages of its pilgrimage and ascent towards its heavenly glory and rest.

PSALM CXX.

This opening Psalm of the series represents Christ in the time of His sojourning on earth, and the Church in the time of her warfare, lamenting the wickedness of those who refuse the "peace of God which passeth all understanding," and are ever ready to contend against Him Who would lead them to the true Salem.

It is, therefore, the Voice of Christ's Mystical Body dwelling in exile from the Presence of God, and carrying on her conflict with the great Enemy. The Church, passing through the wilderness of this world, has often had to say, "We are troubled on every side, yet not distressed ; we are perplexed, but not in despair ; persecuted, but not forsaken ; cast down, but not destroyed." [2 Cor. iv. 8, 9.] But, looking forward and upward to the end of her pilgrimage she beholds the place of God's Presence there, and says also, "We look not at the things which are seen, but at the things which are not seen : for the things which are seen are temporal ; but the things which are not seen are eternal." "When I was in trouble, I called upon the Lord, and He heard me."

PSALM CXXI.

Thus in her pilgrimage the Church lifts up her eyes to look upon "the Holy City, New Jerusalem," whose foundations are in the holy hills, beholding her joy from afar. Yet is she ever drawing nearer and nearer to the help which cometh from the Lord : to

¹ This title has been associated with an ancient Chaldee tradition that after the Captivity a flood poured forth from the earth which reached to the height of fifteen cubits, threatening to overwhelm the whole area of the Temple ; and that its destructive progress was stayed by writing the ineffable Name upon each of the steps.

The XXVII.
Day.
Morning
Prayer.
Rev. vii. 15-17.

6 So that the sun shall not burn thee by day : neither the moon by night.

7 The Lord shall preserve thee from all evil : yea, it is even he that shall keep thy soul.

Isa. lviii. 8. 11.

8 The Lord shall preserve thy going out, and thy coming in : from this time forth for evermore.

THE CXXII PSALM.

Lætatus sum.

A Gradual Psalm.
Mal. iii. 1.
Luke ii. 46. 49.

I WAS glad when they said unto me : We will go into the house of the Lord.

2 Our feet shall stand in thy gates : O Jerusalem.

Eph. ii. 20-22.
Rev. xxi. 16.

3 Jerusalem is built as a city : that is at unity in itself.

Isa. ii. 3.

4 For thither the tribes go up, even the tribes of the Lord : to testify unto Israel, to give thanks unto the Name of the Lord.

Rev. xxii. 3.
Isa. ii. 4.

5 For there is the seat of judgement : even the seat of the house of David.

6 O pray for the peace of Jerusalem : they shall prosper that love thee.

John xiv. 27.
Acts x. 26.

7 Peace be within thy walls : and plenteousness within thy palaces.

8 For my brethren and companions' sakes : I will wish thee prosperity.

Eph. iv. 3.

9 Yea, because of the house of the Lord our God : I will seek to do thee good.

Per diem sol non uret te : neque luna per noctem.

Dominus custodit te ab omni malo : custodiat animam tuam Dominus.

Dominus custodiat introitum tuum et exitum tuum : ex hoc nunc et usque in sæculum.

PSALMUS CXXI.

LÆTATUS sum in his quæ dicta sunt mihi : in domum Domini ibimus. Tuesday Vespers.

Stantes erant pedes nostri : in atriis tuis Hierusalem.

Hierusalem quæ ædificatur ut civitas ; cujus participatio ejus in idipsum :

Illuc enim ascenderunt tribus, tribus Domini : testimonium Israël, ad confitendum Nomini Domini. nomini tuo

Quia illic sederunt sedes in judicio : sedes super domum David.

Rogate quæ ad pacem sunt Hierusalem : et abundantia diligentibus te.

Fiat pax in virtute tuâ : et abundantia in turribus tuis.

Propter fratres meos et proximos meos : loquebar pacem de te :

Propter domum Domini Dei nostri : Dei mei quæsivi bona tibi.

the time when "God shall wipe away all tears from their eyes ; and there shall be no more death, neither sorrow, nor crying, neither shall there be any more pain : for the former things are passed away." [Rev. xxi. 4.]

And even the prospect of God's glory on the distant everlasting hills gives strength to the faith which recognizes His protecting Presence in the Church during the time of warfare and pilgrimage. So the promise is remembered that "none shall stumble or fall" who lean upon the strength of Israel, and that He has said that not even the gates of hell shall prevail against His Church. As the Presence of the Lord was manifested upon the tabernacle in its journeyings through the wilderness, so is it given to the Church in her pilgrimage, and the word is already fulfilled : "My Righteousness shall go before thee : the glory of the Lord shall be thy reward . . . and the Lord shall guide thee continually and satisfy thy soul in drought, and make fat thy bones : and thou shalt be like a watered garden, and like a spring of water, whose waters fail not."

PSALM CXXII.

The New Jerusalem is here set forth as being the treasury of Christ's peace and unity, according to our Lord's words, "My peace I leave with you," and His final prayer, "That they all may

be one." The unity of the Church is symbolized in the Book of Revelation by the figure of a city built four-square, "having twelve foundations and in them the names of the twelve Apostles of the Lamb." And the association of this unity with peace is elaborated by St. Paul when he writes to the Ephesians that they should walk worthy of the vocation with which they are called, "endeavouring to keep the unity of the Spirit in the bond of peace." "For," he adds, "there is one body, and one Spirit, even as ye are called in one hope of your calling ; One Lord, one faith, one baptism, One God and Father of all, Who is above all, and through all, and in you all." And, showing this unity of peace to be in Christ, he shows also that it is maintained by Apostolic order : "And He gave some apostles ; and some prophets ; and some evangelists ; and some pastors and teachers ; for the perfecting of the saints, for the work of the ministry, for the building up of the Body of Christ : till we all come, in the unity of the faith, and of the knowledge of the Son of God, unto a perfect Man, unto the measure of the stature of the fulness of Christ."

From the Church of Christ, therefore, proceeds the peace which Christ left for His people, the "peace which passeth all understanding." Because His throne is within its walls it is a City which is at unity with itself in respect to the essentials of grace, however diverse its gates in the sight of men. Whatever may

THE CXXIII PSALM.

Ad te levavi oculos meos.

The XXVII.
Day.
Morning
Prayer.
A Gradual Psalm.
Isa. lxvi. 1, 2.

UNTO thee lift I up mine eyes :
O thou that dwellest in the
heavens.

2 Behold, even as the eyes of ser-
vants look unto the hand of their
masters, and as the eyes of a maiden
unto the hand of her mistress : even
so our eyes wait upon the Lord our
God, until he have mercy upon us.

Neh. i. 3. 3 Have mercy upon us, O Lord,
have mercy upon us : for we are utterly
despised.

4 Our soul is filled with the scorn-
ful reproof of the wealthy : and with
the despitefulness of the proud.

THE CXXIV PSALM.

Nisi quia Dominus.

A Gradual Psalm.

IF the Lord himself had not been
on our side, now may Israel say :
if the Lord himself had not been on
our side, when men rose up against
us ;

2 They had swallowed us up quick :
when they were so wrathfully dis-
pleased at us.

Isa. xliii. 2. 3 Yea, the waters had drowned us :
and the stream had gone over our soul.

Lam. iii. 4.
Jonah ii. 3. 4 The deep waters of the proud :
had gone even over our soul.

5 But praised be the Lord : who
hath not given us over for a prey unto
their teeth.

6 Our soul is escaped even as a
bird out of the snare of the fowler :
the snare is broken, and we are de-
livered.

PSALMUS CXXII.

AD te levavi oculos meos : qui Tuesday Vespers.
habitas in caelis.

Ecce sicut oculi servorum : in mani-
bus dominorum suorum.

Sicut oculi ancillae in manibus do-
minae suae : ita oculi nostri ad Domi-
num Deum nostrum, donec misereatur
nostri.

Miserere nostri, Domine, miserere
nostri : quia multum repleti sumus
despectione :

contemptione

Quia multum repleta est anima nos-
tra, opprobrium abundantibus : et de-
spectio superbis.

PSALMUS CXXIII.

NISI quia Dominus erat in nobis, Tuesday Vespers.
dicat nunc Israel : nisi quia
Dominus erat in nobis :

Cum exurgerent homines in nos :
forte vivos deglutissent nos :

Cum irasceretur furor eorum in nos : *animus eorum ad-*
forsitan aqua absorbuisset nos. *versus nos velut*
aqua absorbuisset

Torrentem pertransiit anima nos-
tra : forsitan pertransisset anima nostra
aquam intolerabilem.

Benedictus Dominus, qui non dedit
nos : in captionem dentibus eorum.

Anima nostra sicut passer erepta
est : de laqueo venantium :

Laqueus contritus est : et nos libe-
rati sumus.

seem the outward divisions of the one Catholic and Apostolic Church, there is a sacramental unity which must bind together all its parts so long as they are united to the Head. And hence even already the words of the prophet are fulfilled in their degree, though hereafter to receive a more complete fulfilment: "And many people shall go and say, Come ye, and let us go up to the mountain of the Lord, to the house of the God of Jacob: and He will teach us of His ways, and we will walk in His paths; for out of Zion shall go forth the law, and the word of the Lord from Jerusalem. And He shall judge among the nations, and shall rebuke many people: and they shall beat their swords into plowshares, and their spears into pruning-hooks: nation shall not lift up sword against nation, neither shall they learn war any more."

PSALM CXXIII.

This is a prayer of the Church for times of trouble during her pilgrimage. The way of that pilgrimage is not one of unimpeded

progress, for the sin of men brings down the displeasure of God even upon His Holy City, and the Evil One is permitted to bring desolation upon it, so that even "the remnant that are left of the Captivity . . . are in great affliction and reproach: the wall of Jerusalem also is broken down, and the gates thereof are burned with fire." Then her faithful prayer goes up to the throne of God to undo the work of her faithless children, memorializing Him that "they are Thy people and Thine inheritance, which Thou broughtest out by Thy mighty power, and Thy stretched-out arm." [Deut. ix. 29.]

PSALM CXXIV.

This is a thanksgiving, corresponding to the prayer of the preceding Psalm, acknowledging that it is God's arm which has delivered His Church in all time of trouble, and that but for His protecting Providence it could never continue from age to age in the face of opposition from Satan and the world. "When the

The XXVII.
Day.
Morning
Prayer.

7 Our help standeth in the Name of the Lord : who hath made heaven and earth.

THE CXXV PSALM.

Qui confidunt.

A Gradual Psalm.
Matt. xvi. 18.
vii. 25.

THEY that put their trust in the Lord shall be even as the mount Sion : which may not be removed, but standeth fast for ever.

Isa. v. 1, 2.

2 The hills stand about Jerusalem : even so standeth the Lord round about his people, from this time forth for evermore.

Matt. xxiv. 21, 22.
Job ii. 4.

3 For the rod of the ungodly cometh not into the lot of the righteous : lest the righteous put their hand unto wickedness.

2 Cor. xiii. 11.

4 Do well, O Lord : unto those that are good and true of heart.

Isa. lvii. 20.
xlviii. 22.

5 As for such as turn back unto their own wickedness : the Lord shall lead them forth with the evil-doers ; but peace shall be upon Israel.

THE CXXVI PSALM.

In convertendo.

Evening
Prayer.

A Gradual Psalm.
Isa. li. 11.
xxxiv. 10.

WHEN the Lord turned again the captivity of Sion : then were we like unto them that dream.

2 Then was our mouth filled with laughter : and our tongue with joy.

Isa. li. 12
Rev. xv. 3.

3 Then said they among the heathen : The Lord hath done great things for them.

4 Yea, the Lord hath done great things for us already : whereof we rejoice.

Adjutorium nostrum in Nomine Domini : qui fecit cœlum et terram.

PSALMUS CXXIV.

QUI confidunt in Domino, sicut mons Sion : non commovebitur in æternum qui habitat in Hierusalem. Tuesday Vespers.

Montes in circuitu ejus, et Dominus in circuitu populi sui : ex hoc nunc, et usque in sæculum.

Quia non relinquet Dominus virgam peccatorum super sortem justorum : ut non extendant justi ad iniquitatem manus suas.

Benefac, Domine : bonis et rectis corde.

Declinantes autem in obligationes, adducet Dominus cum operantibus iniquitatem : pax super Israël.

PSALMUS CXXV.

IN convertendo Dominus captivitatem Sion : facti sumus sicut consolati. Tuesd., App. and Evv., Vespers.

Tunc repletum est gaudio os nostrum : et lingua nostra exultatione.

Tunc dicent inter gentes : Magnificavit Dominus facere cum eis.

Magnificavit Dominus facere nobiscum : facti sumus lætantes.

Enemy shall come in like a flood, the Spirit of the Lord shall lift up a Standard against him. And the Redeemer shall come to Zion, and unto them that turn from transgression in Jacob, saith the Lord." [Isa. lix. 19, 20.]

PSALM CXXV.

This is another hymn concerning the Lord's protection and care of His Church in the midst of the dangers to which it is subject from foes. It is a House built upon a rock, even the Rock of Christ's Person, and though the winds and storms of persecution may beat against it it cannot fall, nor can the gates of Hell prevail against it, because it is thus securely founded. It is a Vineyard in a very fruitful hill, which the Lord has fenced about with His Providence as Jerusalem was surrounded by its fortress mountains. And though His Church is in the midst of many and great dangers through the strength of the foe without and the weakness of those within, yet He will never suffer it to be overcome by the enemy : "I pray not that Thou shouldst take them out of the

world, but that Thou shouldst keep them from the evil." [John xvii. 15.] He permitted Satan to stretch forth his hand on Job, but there was a restriction laid upon him, "Save his life;" and the effect of this limitation of the "rod of the ungodly" was that "in all this Job sinned not, nor charged God foolishly." Thus does the Lord fulfil His promise to His Church : "When thou passest through the waters, I will be with thee; and through the floods, they shall not overflow thee : when thou walkest through the fire, thou shalt not be burned ; neither shall the flame kindle upon thee. For I am the Lord thy God, the Holy One of Israel, thy Saviour." [Isa. xliii. 2.]

PSALM CXXVI.

This prophecy of Israel's return from the Babylonish Captivity, is also a prediction of the Lord's final reception of His Church out of its captivity in this world to its glory in heaven : and hence it is a hymn based on the constant prayer of the Church, "Thy Kingdom come." When that time arrives, the living shall

The XXVII. 5 Turn our captivity, O Lord : as
Day.
Evening.
Prayer.
Isa. xi. 15, 16.
Isa. ix. 3.
xxxl. 20.
Rev. xxi. 4.
Ecl. xi. 1.
Matt. xiii. 36-39.
Rev. xiv. 14. 16.

6 They that sow in tears : shall
reap in joy.

7 He that now goeth on his way
weeping, and beareth forth good seed :
shall doubtless come again with joy,
and bring his sheaves with him.

THE CXXVII PSALM.

Nisi Dominus.

Churching of
Women.
A Gradual Psalm.
1 Cor. iii. 9.

EXCEPT the Lord build the house :
their labour is but lost that build
it.

2 Except the Lord keep the city :
the watchman waketh but in vain.

3 It is but lost labour that ye haste
to rise up early, and so late take rest,
and eat the bread of carefulness : for
so he giveth his beloved sleep.

[Isa. viii. 18.
Gal. iv. 28.
Gen. xviii. 10.
1 Sam. i. 5, 19.
Luke i. 6, 13.]

4 Lo, children and the fruit of the
womb : are an heritage and gift that
cometh of the Lord.

Ps. xix. 5.

5 Like as the arrows in the hand of
the giant : even so are the young
children.

Isa. xxix. 21.
xxxviii. 10.
1 Cor. xv. 49.
1 John iv. 17.

6 Happy is the man that hath his
quiver full of them : they shall not
be ashamed when they speak with their
enemies in the gate.

THE CXXVIII PSALM.

Beati omnes.

Holy Matrimony.
A Gradual Psalm.

BLESSED are all they that fear
the Lord : and walk in his
ways.

Convertere, Domine, captivitatem
nostram : sicut torrens in Austro.

Qui seminant in lachrymis : in ex-
sultatione metent. *gaudio*

Euntes ibant et flebant : mittentes
semina sua.

Venientes autem venient cum ex-
sultatione : portantes manipulos suos.

PSALMUS CXXVI.

NISI Dominus ædificaverit do- Wed. Vespers.
mum : in vanum laboraverunt *laborant*
qui ædificant eam.

Nisi Dominus eustodierit civitatem :
frustra vigilat qui custodit eam. *in vanum vigilant*
qui custodiunt.

Vanum est vobis ante lucem surgere :
surgite postquam sederitis, qui man-
ducatis panem doloris.

Cum dederit dilectis suis somnum :
ecce, hæreditas Domini filii ; merces
fructus ventris.

Sicut sagittæ in manu potentis :
ita filii excussorum.

Beatus vir qui implevit desiderium
suum ex ipsis : non confundetur cum
loquetur inimicis suis in porta.

PSALMUS CXXVII.

BEATI omnes qui timent Domi- Wed. Vespers.
num : qui ambulant in viis ejus. Holy Matrimony.
Purification of
Women.

be like those that have already been in the state of rest, "and we which are alive, and remain unto the coming of the Lord, shall not prevent them which are asleep . . . the dead in Christ shall rise first : then we which are alive shall be caught up together with them in the clouds, to meet the Lord in the air, and so shall we ever be with the Lord." [1 Thess. iv. 15, 17.] The redeemed will sing of the great things that the Lord has done for them, "Great and marvellous are Thy works, Lord God Almighty : "the ransomed of the Lord shall return, and come to Zion with songs, and everlasting joy upon their heads : they shall obtain joy and gladness, and sorrow and sighing shall flee away." The bread which Christ the Sower hath cast upon the waters shall then be found after many days, and the full blessing revealed of them that sow beside all waters, in the joy with which He shall gather in His harvest. "And I looked, and behold a white cloud, and upon the cloud One sat like unto the Son of Man, having on His head a golden crown, and in His hand a sharp sickle . . . and He that sat on the cloud thrust in His sickle on the earth ; and the earth was reaped."

PSALM CXXVII.

The building of the Temple by Solomon, the re-building of the wall of Jerusalem by Nehemiah, and of the ruined House of the

Lord by Zerubbabel, were all typical of the foundation and building of the City of God, whose walls are Salvation and her gates Praise. It was predicted respecting this "new house" that "The sons of strangers shall build up thy walls, and their kings shall minister unto thee . . . the glory of Lebanon shall come unto thee, the fir-tree, the pine-tree, and the box together, to beautify the place of My sanctuary, and I will make the place of My feet glorious." [Isa. lx. 11, 13.] But it was the sleep of the Beloved by which the Lord built the house, and by which He keeps the City. For as when Adam slept Eve was taken out of his side, so when the Second Adam fell asleep on the Cross there proceeded forth from His side the Sacramental streams by which the children who are the Lord's heritage and gift are new born to Him and nourished up to eternal life.

It is these children who are as arrows in the hand of the Bridegroom, rejoicing as a Giant to run His course : and He is the Man Whose happiness it is to say, "Behold I and the children whom the Lord hath given Me : " because, also, He is their Strength they shall have "boldness in the Day of Judgment" when the great Enemy shall be their accuser before the throne¹.

¹ The "gate" in the last verse may be an antitype of both the "gate of death" and the gate in which the king sat to judge the people's causes. See 2 Sam. xv. 2 ; xix. 8.

The XXVII.

Day.

Evening.

Prayer.

Rev. ii. 26. xv. 3.

Eph. ii. 10.

Heb. iv. 10, 11.

Isa. v. 2. liv. 5.

Jer. ii. 21.

John xv. 5—11.

Rom. xi. 17.

2 For thou shalt eat the labours of
thine hands : O well is thee, and
happy shalt thou be.

3 Thy wife shall be as the fruitful
vine : upon the walls of thine house.

4 Thy children like the olive-
branches : round about thy table.

5 Lo, thus shall the man be blessed :
that feareth the Lord.

Isa. liii. 12.

6 The Lord from out of Sion shall
so bless thee : that thou shalt see
Jerusalem in prosperity all thy life
long.

Isa. liii. 12.

7 Yea, that thou shalt see thy chil-
dren's children : and peace upon
Israel.

THE CXXIX PSALM.

*Sæpe expugnaverunt.*A Gradual Psalm.
Gen. iii. 15.

MANY a time have they fought
against me from my youth up :
may Israel now say.

2 Yea, many a time have they vexed
me from my youth up : but they have
not prevailed against me.

Isa. l. 6. liii. 5.
Matt. xxvii. 26.

3 The plowers plowed upon my
back : and made long furrows.

4 But the righteous Lord : hath
hewn the snares of the ungodly in
pieces.

John xviii. 6.

5 Let them be confounded and
turned backward : as many as have
evil will at Sion.

Isa. xxxvii. 27.

6 Let them be even as the grass
growing upon the house-tops : which
withereth afore it be plucked up ;

Labores manuum tuarum quia man- *fructuum tuorum*
ducabis : beatus es, et bene tibi erit. *manducabis*

Uxor tua sicut vitis abundans : in
lateribus domus tuæ.

Filii tui sicut novellæ olivarum :
in circuitu mensæ tuæ.

Ecce, sic benedicetur homo : qui
timet Dominum.

Benedicat tibi Dominus ex Sion : et
videas bona Hierusalem omnibus die-
bus vitæ tuæ.

Et videas filios filiorum tuorum :
pacem super Israël.

PSALMUS CXXVIII.

SÆPE expugnaverunt me a juven- *Wed. Vespers.*
tute mea : dicat nunc Israël.

Sæpe expugnaverunt me a juven-
tute mea : etenim non potuerunt mihi.

Supra dorsum meum fabricaverunt
peccatores : prolongaverunt iniquita-
tem suam.

Dominus justus concidet cervices
peccatorum : confundantur et conver-
tantur retrorsum omnes qui oderunt
Sion.

Fiant sicut fœnum tectorum : quod *adificiorum*
priusquam evellatur exaruit.

PSALM CXXVIII.

Respecting this Psalm also the words of St. Paul may be put into the mouth of the Psalmist, "I speak concerning Christ and His Church." The figure of marriage is one constantly used in a mystical sense of the union which God establishes between Himself and His people. So He said of old, "Thy maker is thy Husband;" so also when all things are made new the Apocalyptic vision of the glorified Church is of one "prepared as a Bride adorned for her Husband," of whom the angel said, "Come hither, I will show thee the Bride, the Lamb's Wife." [Rev. xxi. 1. 9.]

Thus this Psalm is to be taken, in its highest aspect, as spoken of Christ, "the Man" so often pronounced to be "blessed" throughout the whole Book of Psalms. The "labours of Thine hands" are those marvellous works for which the saints praise the King of Saints [Rev. xv. 3]: "Thy wife" is the Bride of Christ, made one with Himself "the true Vine," which has become the Tree of Life beside His House on earth: "Thy children" are they who have become the children of God through their regeneration. [1 Pet. i. 3. 1 John v. 1.] "Let us be glad,

and rejoice, and give honour to Him; for the marriage of the Lamb is come, and His Wife hath made herself ready."

PSALM CXXIX.

From her youth up to her later ages the world and Satan have fought against the Church, and vexed her and made her to "fill up that which is behind of the afflictions of Christ," [Col. i. 24.] As "He gave His back to the smiters" and was "wounded for our transgressions" by the scourging which He suffered in the hall of Pilate, so the persecutions which fell upon the Church in its youth were as the torture of plowers plowing upon His Mystical Body, and making long furrows with the scourge of wicked tyranny. [Cf. Acts ix. 4, 5.]

Active persecution of this kind is but one phase of that continuous opposition to the work of Christ and His Church which the Apostle speaks of as "crucifying the Son of God afresh." It will never cease until the warfare of the Church is ended, Satan defeated, and all the foes of Christ made His footstool. But as the Lord Himself suffered the plowers to plow upon His back that His sufferings might work the salvation of men, so the persecutions which fall upon the Church are for her purification. At the

The XXVII.
Day.
Evening
Prayer.
Rev. xiv. 14.
Ruth ii. 4.
Ps. cxviii. 26.

7 Whereof the mower filleth not his hand : neither he that bindeth up the sheaves his bosom.

8 So that they who go by say not so much as, The Lord prosper you : we wish you good luck in the Name of the Lord.

THE CXXX PSALM.

De profundis.

Ash-Wednesday,
Evensong.
A Penitential
Psalm.
A Gradual Psalm.
Jonah ii. 2.

OUT of the deep have I called unto thee, O Lord : Lord, hear my voice.

2 O let thine ears consider well : the voice of my complaint.

Nahum i. 6.
Mal. iii. 2.
Job x. 14.
xiv. 16.

3 If thou, Lord, wilt be extreme to mark what is done amiss : O Lord, who may abide it ?

4 For there is mercy with thee : therefore shalt thou be feared.

5 I look for the Lord, my soul doth wait for him : in his word is my trust.

Mark xiii. 35.

6 My soul fleeth unto the Lord : before the morning watch, I say, before the morning watch.

1 Cor. viii. 1.
Nahum i. 7.

7 O Israel, trust in the Lord, for with the Lord there is mercy : and with him is plenteous redemption.

Matt. i. 21.

8 And he shall redeem Israel : from all his sins.

THE CXXXI PSALM.

Domine, non est.

A Gradual Psalm.
Isa. xlii. 2.
Matt. xi. 29.

LORD, I am not high-minded : I have no proud looks.

De quo non implevit manum suam *implebit* qui metit : et sinum suum qui manipulos colligit :

Et non dixerunt qui præteribant, Benedictio Domini super vos : benediximus vobis in Nomine Domini.

PSALMUS CXXIX.

DE profundis clamavi ad te, Domine : Domine, exaudi vocem meam. Wed., Christmas, Vespers, Vigils of the departed.

Fiant aures tuæ intendentes : in in orationem servi tui vocem deprecationis meæ.

Si iniquitates observaveris, Domine : Domine, quis sustinebit ?

Quia apud te propitiatio est : et propter legem tuam sustinui te, Domine.

Sustinuit anima mea in verbo ejus : speravit anima mea in Domino.

A custodia matutina usque ad noctem : speret Israël in Domino.

Quia apud Dominum misericordia : et copiosa apud eum redemptio.

Et ipse redimet Israël : ex omnibus iniquitatibus ejus.

PSALMUS CXXX.

DOMINE, non est exaltatum cor meum : neque elati sunt oculi mei. Wed. Vespers.

last He will make manifest His good Providence in this, and say to the enemies of the new as He did to those of the ancient Israel, "Hast thou not heard long ago how I have done it: and of ancient times that I have formed it: now have I brought it to pass that thou shouldst be to lay defenced cities into ruinous heaps I will turn thee back by the way by which thou camest."

PSALM CXXX.

This is the sixth of the Penitential Psalms: and has also been associated time immemorial with the mourning and watching of survivors over their departed brethren. It bears much similarity to the prayer of Jonah, which begins, "I cried by reason of mine affliction unto the Lord, and He heard me: out of the belly of hell cried I, and Thou heardest my voice." And as our Lord Himself declared that the prophet Jonah was a sign or type of Him so clear as to be evident even to that wicked generation which rejected Him, we have, in this coincidence of the prayer and the Psalm, an evidence that the latter is to be understood, like the other Penitential Psalms, as the words of Christ taking our sins upon Him, and offering up a vicarious penitence, by participation in the fulness of which by His brethren their imperfect

penitence is made acceptable to God.

This Psalm expresses, however, the cry of the penitent in the state of the departed, rather than that of the sinner in the day of probation. As Jonah from his living grave, as Christ from His Cross, so the sinner from his place in the intermediate state calls "out of the deep" upon the mercy of God, pleads the impossibility of salvation if full justice is poured out upon his sins, memorializes God of His mercy through Christ, and lifts up the aspiration of his soul to flee unto the Lord "very early in the" resurrection "morning."

Thus this Psalm finds a proper Antiphon in the words of the prophets Nahum and Zechariah. "Who can stand before His indignation, and who can abide in the fierceness of His anger? His fury is poured out like fire, and the rocks are thrown down by Him. The Lord is good, a stronghold in the Day of trouble; and He knoweth them that trust in Him." "Turn you to the stronghold, ye prisoners of hope." [Zech. ix. 12.]

PSALM CXXXI.

This is the Voice of Him Who, esteeming it no robbery to be even equal with God, yet took upon Him the form of a servant,

The XXVII
Day.
Evening
Prayer.
Matt. xviii. 1-6.

2 I do not exercise myself in great matters : which are too high for me.

3 But I refrain my soul, and keep it low, like as a child that is weaned from his mother : yea, my soul is even as a weaned child.

4 O Israel, trust in the Lord : from this time forth for evermore.

THE CXXXII PSALM.

Memento, Domine.

The XXVIII.
Day.
Morning
Prayer.
Christmas Day,
Evensong.
A Gradual Psalm.
2 Chron. vi. 7.
Eph. iii. 11.

LORD, remember David : and all his trouble ;

2 How he sware unto the Lord : and vowed a vow unto the Almighty God of Jacob ;

3 I will not come within the tabernacle of mine house : nor climb up into my bed ;

4 I will not suffer mine eyes to sleep, nor mine eye-lids to slumber : neither the temples of my head to take any rest ;

Hagg. i. 4.
Luke ix. 58.

5 Until I find out a place for the temple of the Lord : an habitation for the mighty God of Jacob.

Mic. v. 2.

6 Lo, we heard of the same at Ephrata : and found it in the wood.

7 We will go into his tabernacle : and fall low on our knees before his footstool.

Numb. x. 35.
2 Chron. vi. 41.
Luke i. 68.

8 Arise, O Lord, into thy resting-place : thou, and the ark of thy strength.

Matt. and Evensong Suffrages.

9 Let thy priests be clothed with righteousness : and let thy saints sing with joyfulness.

2 Chron. vi. 42.

10 For thy servant David's sake : turn not away the presence of thine Anointed.

Neque ambulavi in magnis : neque in mirabilibus super me.

Si non humiliter sentiebam : sed exaltavi animam meam.

Sicut ablactatus est super matre sua : ita retributio in anima mea.

retribues in

Speret Israël in Domino : ex hoc nunc, et usque in sæculum.

PSALMUS CXXXI.

MEMENTO, Domine, David : et omnis mansuetudinis ejus.

Thursd., Christmas, Vespers.

Sicut juravit Domino : votum vovit Deo Jacob :

Si introiero in tabernaculum domus meæ : si ascendero in lectum strati mei :

Si dederò somnum oculis meis : et palpebris meis dormitationem ;

Et requiem temporibus meis, donec inveniam locum Domino : tabernaculum Deo Jacob.

Ecce, audivimus eam in Ephrata : invenimus eam in campis silvæ.

Introibimus in tabernaculum ejus : adorabimus in loco ubi steterunt pedes ejus.

Introivimus . . . adoravimus

Surge, Domine, in requiem tuam : tu et arca sanctificationis tuæ.

Sacerdotes tui induantur justitiam : et sancti tui exsultent.

laletur

Propter David servum tuum : non avertas faciem Christi tui.

veiled His Divine glory in a tabernacle of flesh, and came into the world in the likeness of sinful men. Such was our Lord, and such was the Example which He set forth, "Learn of Me, for I am meek and lowly of heart." On more than one occasion the people desired to take the holy Jesus and set Him up for their King, but His ordinary practice on such occasions was to go apart from the multitude, as not exercising Himself in great matters ; and only once, immediately before His sufferings, did He permit Himself to be led in triumph. Thus His holy Example illustrated the benediction which He uttered, "Blessed are the meek : for they shall inherit the earth." [Matt. v. 5.] And as our Lord, in the Psalms, mostly speaks in the Person of His Mystical Body, so here we may doubtless see both example and precept teaching us that the Church should ever be kept apart from schemes of secular ambition, and "exercised" only in such matters as are connected with her spiritual work.

PSALM CXXXII.

When David sang respecting the vow which He had made to God to build Him a house [vv. 1-10], and respecting God's promise to him as to the firm establishment of his seed in Sion [vv. 11-19], he was mystically indicating (1) the Son of David tabernacled among men in the flesh that He might find out a place for the spiritual Temple, and (2) the promises of God made to his children for the sake of His Beloved Son. "But thou, Bethlehem Ephrata, though thou be little among the thousands of Judah, yet out of thee shall He come forth unto Me that is to be Ruler in Israel, Whose goings forth have been from of old, from the days of eternity." [Mic. v. 2. Matt. ii. 6.]

In this Psalm, God is therefore memorialized of the "good pleasure" which the Son of God "hath purposed in Himself," and of "the eternal purpose which He purposed in Christ Jesus."

The XXVIII. 11 The Lord hath made a faithful
Day.
Morning
Prayer.
Acts ii. 30.
2 Chron. vi. 16,
17.

12 Of the fruit of thy body : shall
I set upon thy seat.

13 If thy children will keep my
covenant, and my testimonies that I
shall learn them : their children also
shall sit upon thy seat for evermore.

Isa. xxiv. 23. 14 For the Lord hath chosen Sion
to be an habitation for himself : he
hath longed for her.

Hagg. ii. 7. 9. 15 This shall be my rest for ever :
here will I dwell, for I have a delight
therein.

Joel ii. 19. 16 I will bless her victuals with in-
crease : and will satisfy her poor with
bread.

Rev. v. 10.
xix. 8. 17 I will deck her priests with
health : and her saints shall rejoice
and sing.

Luke i. 69. 79.
ii. 32.
John v. 35. 18 There shall I make the horn of
David to flourish : I have ordained a
lantern for mine Anointed.

John xix. 2.
Rev. xiv. 14.
xix. 12.
1 Pet. v. 4. 19 As for his enemies, I shall clothe
them with shame : but upon himself
shall his crown flourish.

THE CXXXIII PSALM.

Ecce, quam bonum.

A Gradual Psalm.
John xvii. 22.
1 Cor. xii. 12-14.
Eph. iv. 8-11.
1 John iv. 7.

BEHOLD, how good and joyful a
thing it is : brethren, to dwell
together in unity.

1 John ii. 20. 2 It is like the precious ointment
upon the head, that ran down unto the
beard : even unto Aaron's beard, and
went down to the skirts of his clothing.

Hos. xiv. 5. 3 Like as the dew of Hermon :
which fell upon the hill of Sion.

John xv. 4. 4 For there the Lord promised his
blessing : and life for evermore.

Juravit Dominus David veritatem,
et non frustrabitur eam : de fructu
ventris tui ponam super sedem tuam. *sedem meam*

Si custodierint filii tui testamentum
meum : et testimonia mea hæc quæ
docebo eos :

Et filii eorum usque in sæculum :
sedeant super sedem tuam. *sedem meam*

Quoniam elegit Dominus Sion : *preelegit*
elegit eam in habitationem sibi.

Hæc requies mea in sæculum sæculi :
hic habitabo ; quoniam elegi eam. *preelegi*

Vidua ejus benedicens benedicam :
pauperes ejus saturabo panibus.

Sacerdotes ejus induam salutari : et
sancti ejus exsultatione exsultabunt.

Illuc producam cornu David : paravi
lucernam Christo meo.

Inimicos ejus induam confusione :
super ipsum autem effloreat sanctifi-
catio mea.

PSALMUS CXXXII.

ECCE, quam bonum et quam jucun- Thurs. Vespers.
dum : habitare fratres in unum.

Sicut unguentum in capite : quod
descendit in barbam, barbam Aaron :

Quod descendit in oram vestimenti
ejus : sicut ros Hermon, qui descendit
in montem Sion.

Quoniam illic mandavit Dominus
benedictionem : et vitam usque in
sæculum.

that the WORD should become flesh and dwell among us, and that
"the Lord of hosts shall reign in Mount Zion, and in Jerusalem,
and before His ancients, gloriously." "He has chosen for a
rest," says St. Hilary, "those of whom the Lord says in the
Gospel, 'No man can come to Me, except the Father which hath
sent Me draw him.' He has chosen that holy Zion, that heavenly
Jerusalem, to wit, the harmonious company of the faithful, and
the souls hallowed by the sacraments of the Church, to the end
that in them, as in a reasonable and intelligent habitation,
thoroughly cleansed, and eternal through the glory of the Re-
surrection, the reasonable and intelligent, and undefiled, and eter-
nal nature of His ineffable Divinity may rest."

Dwelling in His Church here, Christ thus reigns in His chosen

habitation, blessing her corn and wine with sacramental increase
that they may satisfy her poor with the Bread of Life. There
does God make the horn of the Son of David to flourish, and there
He has ordained a City set on an hill to be a lantern for His
Christ. Hereafter all things will be put under His feet, and His
enemies shall be clothed with shame when they see the crown of
thorns blossoming into the *corona radiata* of an Imperial glory,
the sign of just judgment, and of everlasting dominion.

PSALM CXXXIII.

This is a song of the Church respecting the Indwelling of the
Holy Ghost in the Mystical Body of Christ. It is this by which
the Unity of the Church is originated and maintained through

THE CXXXIV PSALM.

Ecce nunc.

The XXVIII.
Day.
Morning
Prayer.
A Gradual Psalm.
Heb. xii. 22-24.
Rev. vii. 15.
1 Chron. ix. 33.

BEHOLD now, praise the Lord :
all ye servants of the Lord ;
2 Ye that by night stand in the
house of the Lord : even in the courts
of the house of our God.

3 Lift up your hands in the sanc-
tuary : and praise the Lord.

4 The Lord that made heaven and
earth : give thee blessing out of
Sion.

Eph. vi. 18.
2 Tim. i. 18.

THE CXXXV PSALM.

Laudate Nomen.

Col. iii. 16.

OPRAISE the Lord, laud ye the
Name of the Lord : praise it,
O ye servants of the Lord ;

2 Ye that stand in the house of the
Lord : in the courts of the house of
our God.

3 O praise the Lord, for the Lord
is gracious : O sing praises unto his
Name, for it is lovely.

4 For why? the Lord hath chosen
Jacob unto himself : and Israel for
his own possession.

5 For I know that the Lord is
great : and that our Lord is above all
gods.

6 Whatsoever the Lord pleased,
that did he in heaven, and in earth :
and in the sea, and in all deep places.

7 He bringeth forth the clouds from
the ends of the world : and sendeth
forth lightnings with the rain, bring-
ing the winds out of his treasures.

Exod. xix. 5.
Deut. vii. 6.
Tit. ii. 14.
1 Pet. ii. 9.

Jer. x. 13.
xiv. 22. li. 16.
Job xxxviii. 22.

PSALMUS CXXXIII.

ECCE, nunc, benedicite Dominum : Complute.
omnes servi Domini.

Qui statis in domo Domini : in
atriis domus Dei nostri.

In noctibus extollite manus vestras
in sancta : et benedicite Dominum.

Benedicat te Dominus ex Sion : qui
fecit cœlum et terram.

PSALMUS CXXXIV.

LAUDATE Nomen Domini : lau- Thursd. Vespera
date, servi Dominum.

Qui statis in domo Domini : in
atriis domus Dei nostri.

Laudate Dominum, quia bonus Do- *benignus est*
minus : psallite Nomen ejus, quoniam *Dominus*
suave.

Quoniam Jacob elegit sibi Dominus :
Israel in possessionem sibi.

Quia ego cognovi quod magnus est
Dominus : et Deus noster præ omni-
bus diis.

Omnia quæcumque voluit Dominus,
fecit in cœlo et in terra : in mari et in
omnibus abyssis. *in abyssis*

Educens nubes ab extremo terræ :
fulgura in pluviam fecit.

Qui producit ventos de thesauris

the union of the members with the Head, the engrafting and growth of the branches in the Vine. Poured out first upon Christ our High Priest, to Whom "God giveth not the Spirit by measure," it flowed down from Him to the Apostles, from the Apostles to the elect of God's ancient Israel, and thence to the Gentiles. Thus the superabundance of the heavenly Gift was bestowed upon the Body of Christ as the anointing oil poured forth upon the head of Aaron, so that its unction extended to the very skirts of his clothing: as the fertilizing dew which God sends forth to water the earth, and to cause it to bring forth much fruit to perfection. By such an indwelling of the Holy Ghost was the prayer of our Lord fulfilled, "That they all may be one; as Thou, Father, art in Me, and I in Thee, that they also may be one in us." "And after these things I heard a great voice of much people in Heaven." [Rev. xix. 1.]

PSALM CXXXIV.

The Evensong of the Church day by day has always been associated with thoughts of the night which is at hand in the unseen world. So this ancient Complute Psalm looks to the condition

of those members of Christ's Body who are in the state of the departed, in the darkness of night so far as our external vision is concerned, but who, in the Light of Christ's Presence, are yet united with the Church on earth in the one work of praising the Lord: the one work of those who "are before the throne of God, and serve Him day and night in His Temple."

The Church Militant, therefore, calls to the Church in the intermediate state to continue the work of God's praise; and offers up her supplication for the departed, that the Lord Who made Heaven and earth, being their Lord still, will grant to them the blessed benefits of Christ's Passion from out of the inexhaustible stores of His Sion. "The Lord grant unto him that he may find mercy of the Lord in that Day."

PSALM CXXXV.

The antiphonal structure of each verse of this Psalm marks it especially with the characteristic which belongs to many others, that indicated by the heavenly worship seen and heard by Isaiah: "And one cried unto another, and said." Each verse contains what we are accustomed to call a versicle and response, priests

The XXVIII. 8 He smote the first-born of Egypt :
Day.
Morning
Prayer.
Exod. xii. 12. 29. both of man and beast.

9 He hath sent tokens and wonders into the midst of thee, O thou land of Egypt : upon Pharaoh, and all his servants.

10 He smote divers nations : and slew mighty kings ;

Deut. iii. 6. 10. 11 Schon king of the Amorites, and Og the king of Basan : and all the kingdoms of Canaan ;

12 And gave their land to be an heritage : even an heritage unto Israel his people.

13 Thy Name, O Lord, endureth for ever : so doth thy memorial, O Lord, from one generation to another.

Deut. xxxii. 36. 14 For the Lord will avenge his people : and be gracious unto his servants.

Ps. cxv. 4. 15 As for the images of the heathen, they are but silver and gold : the work of men's hands.

Ps. cxv. 5. 16 They have mouths, and speak not : eyes have they, but they see not.

Ps. cxv. 6. 17 They have ears, and yet they hear not : neither is there any breath in their mouths.

Ps. cxv. 8. 18 They that make them are like unto them : and so are all they that put their trust in them.

Ps. cxv. 9, 10. 19 Praise the Lord, ye house of Israel : praise the Lord, ye house of Aaron.

Ps. cxv. 11. 20 Praise the Lord, ye house of Levi : ye that fear the Lord, praise the Lord.

21 Praised be the Lord out of Zion : who dwelleth at Jerusalem.

THE CXXXVI PSALM.

Confitemini.

Evening
Prayer.
1 Chron. xvi. 43.
2 Chron. v. 13.

O GIVE thanks unto the Lord, for he is gracious : and his mercy endureth for ever.

suis: qui percussit primogenita Ægypti, ab homine usque ad pecus.

Et misit signa et prodigia in medio tui, Ægypte: in Pharaonem et in omnes servos ejus.

Qui percussit gentes multas: et occidit reges fortes.

Schon regem Amorrhæorum, et Og regem Basan: et omnia regna Chanaan. Chanaan occidit

Et dedit terram eorum hæreditatem: hæreditatem Israël populo suo.

Domine, Nomen tuum in æternum: Domine, memoriale tuum in generatione et generationem. *in sæculum sæculi*

Quia judicabit Dominus populum suum: et in servis suis deprecabitur. *consolabitur*

Simulachra gentium argentum et aurum: opera manuum hominum.

Os habent, et non loquentur: oculos habent, et non videbunt.

Aures habent, et non audient: neque enim est spiritus in ore ipsorum. *non audient nares habent et non odorabunt. Manus habent et non palpabunt, pedes habent et non ambulabunt. Non ciabunt in quiete suo neque enim est spiritus, &c.*

Similes illis fiant qui faciunt ea: et omnes qui confidunt in eis.

Domus Israël, benedicite Dominum: domus Aaron, benedicite Dominum.

Domus Levi, benedicite Dominum: qui timetis Dominum, benedicite Dominum.

Benedictus Dominus ex Sion: qui habitat in Hierusalem.

PSALMUS CXXXV.

CONFITEMINI Domino, quoniam bonus: quoniam in æternum misericordia ejus. *Thursd. Vespers. in sæculum*

and people "teaching and admonishing one another in psalms and hymns and spiritual songs." This is most conspicuous in the first and last three verses, but the others also are evidently intended to be "cast," as it has been said, "from one to the other;" and in carrying out this purpose the Psalmist has been following a Divine pattern, shown to him in the mount of God.

In this Psalm the Church again praises God for His continuous mercy and goodness towards her in the days of His ancient as in those of His new Israel: and the greatness of this mercy is set

forth by such references to the majesty and power of God as declare throughout that "the Lord thy God giveth thee not this good land to possess it for thy righteousness," but for His holy Name's sake, that "great Name" which He "will sanctify." [Deut. ix. 6. Ezek. xxxvi. 22.] And as it was a perpetual subject of rejoicing among God's ancient people that He had thus chosen them from among all nations as a people among whom He might dwell and manifest forth His glory, so the Presence of Christ in His Church is still the chief subject of praise. "What-

The XXVIII. Day. Evening Prayer.	2 O give thanks unto the God of all gods : for his mercy endureth for ever.	Confitemini Deo deorum : quoniam in æternum misericordia ejus.
Exod. xv. 11.	3 O thank the Lord of all lords : for his mercy endureth for ever.	Confitemini Domino dominorum : quoniam in æternum misericordia ejus.
Prov. iii. 19, 20.	4 Who only doeth great wonders : for his mercy endureth for ever.	Qui facit mirabilia magna solus : <i>fecit</i> quoniam in æternum misericordia ejus.
Gen. i. 2. Isa. lv. 1. John vii. 37.	5 Who by his excellent wisdom made the heavens : for his mercy endureth for ever.	Qui fecit ccelos in intellectu : quoniam in æternum misericordia ejus.
Gen. i. 16—18.	6 Who laid out the earth above the waters : for his mercy endureth for ever.	Qui firmavit terram super aquas : quoniam in æternum misericordia ejus.
John i. 9.	7 Who hath made great lights : for his mercy endureth for ever ;	Qui fecit luminaria magna : quoniam in æternum misericordia ejus.
Isa. lx. 20. Dan. xii. 3. Matt. v. 14.	8 The sun to rule the day : for his mercy endureth for ever ;	Solem in potestatem diei : quoniam in æternum misericordia ejus.
	9 The moon and the stars to govern the night : for his mercy endureth for ever.	Lunam et stellas in potestatem noctis : quoniam in æternum misericordia ejus.
	10 Who smote Egypt with their first-born : for his mercy endureth for ever ;	Qui percussit Ægyptum cum primogenitis eorum : quoniam in æternum misericordia ejus.
	11 And brought out Israel from among them : for his mercy endureth for ever ;	Qui eduxit Israël de medio eorum : quoniam in æternum misericordia ejus.
Exod. vi. 6.	12 With a mighty hand, and stretched out arm : for his mercy endureth for ever.	In manu potenti et brachio excelso : <i>manu fortis</i> quoniam in æternum misericordia ejus.
Exod. xiv. 21.	13 Who divided the Red sea in two parts : for his mercy endureth for ever ;	Qui divisit mare Rubrum in divisiones : quoniam in æternum misericordia ejus.
Exod. xiv. 22, 29.	14 And made Israel to go through the midst of it : for his mercy endureth for ever.	Et eduxit Israël per medium ejus : quoniam in æternum misericordia ejus.
Exod. xiv. 27.	15 But as for Pharaoh and his host, he overthrew them in the Red sea : for his mercy endureth for ever.	Et excussit Pharaonem et virtutem <i>exercitum</i> ejus in mari Rubro : quoniam in æternum misericordia ejus.
	16 Who led his people through the wilderness : for his mercy endureth for ever.	Qui traduxit populum suum per desertum. <i>per desertum. Qui eduxit aquam de petra rupis. Qui percussit</i>

soever the Lord pleased, that did He in Heaven and in earth, and in the sea, and in all deep places," but He condescended to come down and take Human Nature upon Him, and, considering not His own Almighty and irresistible will alone, took pity also upon a fallen world. "Behold, the heaven and heaven of heavens cannot contain Thee; how much less this house that I have builded! Yet have Thou respect unto the prayer of Thy Servant, and to His supplication, O Lord My God."

PSALM CXXXVI.

God is here praised as the Creator, Preserver, and Giver of Life, and we are taught by the third and the last verses to offer up the Psalm as a tribute of praise to Him "by Whom all things were made," and by Whom the Light and Life of grace came into the world; to Him Whom the Church in Heaven praises as "King of kings, and Lord of lords."

Thus interpreted, the Psalm divides itself (after the Introductory verses) into three sections. In the first section [vv. 4—9] the marvels of Creation are set forth as tokens of the mercy of the Lord: a mercy whose objects may extend far beyond the boundaries of our own world, but of which our own experience gives us abundant reason to sing that it endureth for ever. But the great wonders of the natural world are types and symbols of those in the spiritual world. The heavens are glorified Church: the earth is the Church in its militant condition. And because the Militant Church is that wherein souls are made fit for the Church glorified, therefore it is laid out above (or founded on) the waters of grace, wherein all souls are new born, and respecting which the invitation is ever going forth, "Ho! every one that thirsteth, come ye to the waters." "If any man is athirst, let him come unto Me, and drink." The "great lights" are the Sun of Righteousness, "Light of Light," and the "lesser

The XXVIII.
Day.
Evening
Prayer.

17 Who smote great kings : for his mercy endureth for ever ;

18 Yea, and slew mighty kings : for his mercy endureth for ever ;

19 Sehon king of the Amorites : for his mercy endureth for ever ;

20 And Og the king of Basan : for his mercy endureth for ever ;

21 And gave away their land for an heritage : for his mercy endureth for ever ;

22 Even for an heritage unto Israel his servant : for his mercy endureth for ever.

23 Who remembered us when we were in trouble : for his mercy endureth for ever ;

24 And hath delivered us from our enemies : for his mercy endureth for ever.

John vi. 51.

25 Who giveth food to all flesh : for his mercy endureth for ever.

26 O give thanks unto the God of heaven : for his mercy endureth for ever.

27 O give thanks unto the Lord of lords : for his mercy endureth for ever.

THE CXXXVII PSALM.

Super flumina.

Rev. xvii. 1-5.

BY the waters of Babylon we sat down and wept : when we remembered thee, O Sion.

Rev. v. 8. xiv. 2. xv. 2.

2 As for our harps, we hanged them up : upon the trees that are therein.

3 For they that led us away captive, required of us then a song, and melody, in our heaviness : Sing us one of the songs of Sion.

Qui percussit reges magnos : quoniam in æternum misericordia ejus. reges mirabiles

Et occidit reges fortes : quoniam in æternum misericordia ejus.

Sehon regem Amorrhæorum : quoniam in æternum misericordia ejus.

Et Og regem Basan : quoniam in æternum misericordia ejus.

Et dedit terram eorum hæreditatem : quoniam in æternum misericordia ejus.

Hæreditatem Israël servo suo : quoniam in æternum misericordia ejus.

Qui in humilitate nostra memor fuit nostri : quoniam in æternum misericordia ejus.

Et redemit nos ab inimicis nostris : de manu inimicorum nostrorum quoniam in æternum misericordia ejus.

Qui dat escam omni carni : quoniam in æternum misericordia ejus. Qui dedit

Confitemini Deo cæli : quoniam in æternum misericordia ejus.

Confitemini Domino dominorum : quoniam in æternum misericordia ejus.

PSALMUS CXXXVI.

SUPER flumina Babylonis, illic sedimus et flevimus : dum recordamur tui, Sion. Thursd. Vesperæ

In salicibus in medio ejus : suspendimus organa nostra.

Quia illic interrogaverunt nos : qui captivos duxerunt nos, verba cantionum :

Et qui abduxerunt nos : Hymnum cantate nobis de canticis Sion.

light," the Church, which derives all her light from Him, that she may shed it abroad on men during the "night" of His absence from their sight: the stars are they of whom the prophet said, "They that turn many to righteousness" shall shine "as the stars for ever and ever," and of whom our Lord said, "Ye are the light of the world."

In the second section [vv. 10-22] the mercy of the Lord is magnified for delivering human nature from the power of the Evil One, and the Church from the opposition of Antichrist: the progress of His people being symbolized by the triumphant march of Israel in the face of all her enemies; and the foes of Christ and His Church,—Satan and all his Antichristian agents,—by Pharaoh, the great and mighty kings, Sehon and Og. Thus is signified how the "Prince of this world" is to be deprived of that dominion over which he has exercised his power since the Fall, and how the heritage is to be given to Israel God's servant, the Lord Jesus, and to His Mystical Body.

The third section consists of verses 23, 24, and 25, and is characterized by the latter verse especially, in which is signified the mercy of the Second Person of the Blessed Trinity in giving Himself to be the "Living Bread," given for "the life of the world."

Thus recounting the mercies of her Saviour, the Church returns to her first strain of praise, "O give thanks unto the Lord of lords, for His mercy endureth for ever."

PSALM CXXXVII.

The pathos of this sorrowful strain looks beyond the exile and captivity of the Jews, and sets before God the longing of His Church for that Paradise out of which she was driven by the Fall, but to which she hopes to return after the destruction of the mystical Babylon [Rev. xviii.—xxii.]—that great world of confusion which has broken up the order and harmony of the Creator's good work.

In the Sion of God's Presence the four-and-twenty elders are

The XXVIII.
Day.
Evening
Prayer.

4 How shall we sing the Lord's song : in a strange land ?

5 If I forget thee, O Jerusalem : let my right hand forget her cunning.

Job xxix. 10.

6 If I do not remember thee; let my tongue cleave to the roof of my mouth : yea, if I prefer not Jerusalem in my mirth.

Lam. iv. 22.
Ezek. xxv. 12-14.

7 Remember the children of Edom, O Lord, in the day of Jerusalem : how they said, Down with it, down with it even to the ground.

Rev. vi. 10.
xix. 24.

8 O daughter of Babylon, wasted with misery : yea, happy shall he be that rewardeth thee, as thou hast served us.

Isa. xlii. 16.
Nahum iii. 10.
Rev. xviii. 6. 21.
Matt. xxi. 43.

9 Blessed shall he be, that taketh thy children : and throweth them against the stones.

THE CXXXVIII PSALM.

Confitebor tibi.

Heb. xii. 22.
1 Cor. viii. 5.

I WILL give thanks unto thee, O Lord, with my whole heart : even before the gods will I sing praise unto thee.

2 I will worship toward thy holy temple, and praise thy Name, because of thy lovingkindness and truth : for thou hast magnified thy Name and thy Word above all things.

Eph. iii. 16. 20.

3 When I called upon thee, thou heardest me : and enduedst my soul with much strength.

4 All the kings of the earth shall praise thee, O Lord : for they have heard the words of thy mouth.

Micah iv. 1. 2.
Isa. ii. 2, 3.

5 Yea, they shall sing in the ways of the Lord : that great is the glory of the Lord.

Quomodo cantabimus canticum Domini : in terra aliena ?

Si oblitus fuero tui, Hierusalem : oblivioni detur dextera mea.

obliviscatur me dext.

Adhæreat lingua mea faucibus meis : si non meminero tui :

Si non proposuero Hierusalem : in principio lætitiæ meæ.

Memor esto, Domine, filiorum Edom : in die Hierusalem ;

Qui dicunt, Exinanite, exinanite : usque ad fundamentum in ea.

Filia Babylonis misera : beatus, qui retribuet tibi retributionem tuam, quam retribuisti nobis.

Beatus qui tenebit : et allidet parvulos tuos ad petram.

PSALMUS CXXXVII.

CONFITEBOR tibi, Domine, in toto corde meo : quoniam audisti verba oris mei.

Frid., St. Michael, Vespers. Vigils of the departed. exaudisti omnia verba

In conspectu angelorum psallam tibi : adorabo ad templum sanctum tuum, et confitebor Nomini tuo.

Super misericordia tua et veritate tua : quoniam magnificasti super omne Nomen sanctum tuum.

In quacunque die invocavero te, exaudi me : multiplicabis in anima mea virtutem.

virtutem tuam

Confiteantur tibi, Domine, omnes reges terræ : quia audierunt omnia verba oris tui.

Et cantent in viis Domini : quoniam magna est gloria Domini.

in canticis Domini

represented as "having every one of them harps," the New Song is "the voice of harpers harping with their harps," the martyrs "stand on the sea of glass having the harps of God," and when Babylon is fallen "the voice of harpers" is heard in her no more. Thus is symbolized the restoration to the redeemed of the joys from which the Church has been exiled while it dwelt in the "strange land" of a world which was held captive in the bondage of Satan. And while in that land, she is ever looking forward to the bliss of a restored Paradise; a Jerusalem, "new" indeed, yet such as that happy place in which mankind could at first sing the Lord's song to the praise of their Creator in His Visible Presence, the Object of their worship speaking to them, and "walking in the garden."

"Love not the world, neither the things that are in the world," is thus the tone of this Psalm. The mystical Babylon is ever at enmity against God, and the prayer of His Church is ever that all may be destroyed which is not for His glory. Since, then,

"in her was found the blood of prophets and of saints, and of all that were slain upon the earth;" therefore the voice comes even from Heaven, "Reward her even as she rewarded you, and double unto her double according to her works."

PSALM CXXXVIII.

This Psalm may have been written by David when he was living as an exile in an idolatrous kingdom, and when he would be the more fervently calling upon God, because walking in the midst of trouble. It may have been upon the lips of the three young confessors as they walked in the midst of the furnace of Nebuchadnezzar : or of Daniel as he knelt three times a day before his God as aforesaid, with his face toward Jerusalem, notwithstanding the cruel devices of his enemies to put him to death : or it may have been the song of those who sang praises at midnight in the prison, when they were brought before rulers and kings for Christ's sake. But more than all it is the voice of Christ

The XXVIII.
Day.
Evening
Prayer.

6 For though the Lord be high,
yet hath he respect unto the lowly :
as for the proud, he beholdeth them
afar off.

Isa. xliii. 2.
Heb. iv. 15.

7 Though I walk in the midst of
trouble, yet shalt thou refresh me :
thou shalt stretch forth thy hand upon
the furiousness of mine enemies, and
thy right hand shall save me.

Phil. ii. 6.

8 The Lord shall make good his
lovingkindness toward me : yea, thy
mercy, O Lord, endureth for ever ;
despise not then the works of thine
own hands.

THE CXXXIX PSALM.

Domine, probasti.

The XXIX.
Day.
Morning
Prayer.
Job xiii. 9.
xxx. 4.
Heb. iv. 13.

O LORD, thou hast searched me
out, and known me : thou knowest
my down-sitting, and mine up-
rising ; thou understandest my thoughts
long before.

2 Thou art about my path, and
about my bed : and spiest out all my
ways.

3 For lo, there is not a word in my
tongue : but thou, O Lord, knowest
it altogether.

Matt. xx. 1.

4 Thou hast fashioned me behind
and before : and laid thine hand upon
me.

5 Such knowledge is too wonderful
and excellent for me : I cannot attain
unto it.

6 Whither shall I go then from thy
Spirit : or whither shall I go then
from thy presence ?

Jer. xxiii. 23.
Amos ix. 2.

7 If I climb up into heaven, thou
art there : if I go down to hell, thou
art there also.

Quoniam excelsus Dominus, et hu-
milia respicit : et alta a longe cog-
noscit.

Si ambulavero in medio tribulationis,
vivificabis me : et super iram inimico-
rum meorum extendisti manum tuam,
et salvum me fecit dextera tua.

Dominus retribuet pro me ; Domine,
misericordia tua in sæculum : opera
manuum tuarum ne despicias.

PSALMUS CXXXVIII.

DOMINE, probasti me, et cogno-
visti me : tu cognovisti ses-
sionem meam et resurrectionem meam.

Friday, App. and
Evv., Vespers.
Commendation of
Souls.

Intellexisti cogitationes meas de
longe : semitam meam et funiculum
meum investigasti.

*directionem meam
invest.*

Et omnes vias meas prævidisti : quia
non est sermo in lingua mea. *non est dolus*

Ecce, Domine, tu cognovisti omnia,
novissima et antiqua : tu formasti me,
et posuisti super me manum tuam.

Mirabilis facta est scientia tua ex
me : confortata est, et non potero ad
eam.

Quo ibo a Spiritu tuo ? et quo a
facie tua fugiam ?

Si ascendero in cælum, tu illic es :
si descendero in infernum, ades.

speaking for Himself and for His Mystical Body, praising and
thanking God because He has magnified His Name and His
Incarnate WORD above all things, even through the trouble
and affliction of the Cross. For when He called upon His
Father, His voice was heard, and His soul was endued with
strength to subdue all the kings of the earth to His allegiance,
so that they should "sing in the ways of the Lord," acknowledg-
ing that the kingdoms of this world are become the kingdoms of
the Lord and of His Christ.

And though the Church walk in the midst of trouble, as Christ
did, she is the work of the Saviour's "own hands," Whose mercy
endureth for ever, and Who will not despise or forsake that which
He has new created.

PSALM CXXXIX.

The ancient Introit of the Church of England for Low Sunday
applied a portion of this Psalm to our Lord's Resurrection :

"When I wake up, I am present with Thee. Alleluia. Thou
hast laid Thine hand upon Me. Alleluia. Such knowledge is
too wonderful for Me. Alleluia. O Lord, Thou hast searched Me
out and known Me : Thou knowest My down-sitting and Mine
up-rising." This beautiful use of the first and fifth verses indi-
cates to us the primary spiritual interpretation of the Psalm as
relating to the Incarnation of our Blessed Lord, and to the forma-
tion of His Mystical Body, the Church. "Conceived by the Holy
Ghost, born of the Virgin Mary," the Human Nature of the holy
Jesus attained the climax of that mystery attending the origin
and growth of all our kind, and of none could it be so fully said,
"Thou hast fashioned Me behind and before : and laid Thine hand
upon Me." It is, therefore, as if the Human Nature was speak-
ing to the Divine Nature : "Thou hast fashioned Me by the over-
shadowing with which Thou hast covered Me in My Mother's
womb ; Thou hast united Me inseparably with the overshadowing
Spirit ; Thou hast taken Me into Thee, so that I cannot be sepa-

The XXIX.
Day.
Morning
Prayer.

8 If I take the wings of the morning : and remain in the uttermost parts of the sea ;

9 Even there also shall thy hand lead me : and thy right hand shall hold*me.

Gen. iii. 8. 10 If I say, Peradventure the darkness shall cover me : then shall my night be turned to day.

Isa. l. 10. Job xxxiv. 22. 11 Yea, the darkness is no darkness with thee, but the night is as clear as the day : the darkness and light to thee are both alike.

Eph. iv. 24. 12 For my reins are thine : thou hast covered me in my mother's womb.

Job x. 11. 13 I will give thanks unto thee, for I am fearfully and wonderfully made : marvellous are thy works, and that my soul knoweth right well.

Ecc. xi. 5. Eph. iv. 16. 14 My bones are not hid from thee : though I be made secretly, and fashioned beneath in the earth.

15 Thine eyes did see my substance, yet being imperfect : and in thy book were all my members written ;

Rom. iv. 17. 16 Which day by day were fashioned : when as yet there was none of them.

17 How dear are thy counsels unto me, O God : O how great is the sum of them !

18 If I tell them, they are more in number than the sand : when I wake up, I am present with thee.

19 Wilt thou not slay the wicked, O God : depart from me, ye blood-thirsty men.

Job xxi. 15. 20 For they speak unrighteously against thee : and thine enemies take thy Name in vain.

Si sumpsero pennas meas diluculo : ante lucem . . . in postremo maris
et habitavero in extremis maris ;

Etenim illuc manus tua deducet me :
et tenebit me dextera tua.

Et dixi, Forsitan tenebræ conculcabit me : et nox illuminatio mea in deliciis meis.

Quia tenebræ non obscurabuntur a te, et nox sicut dies illuminabitur : sicut tenebræ ejus, ita et lumen ejus.

Quia tu possedisti renes meos : sustulisti me de utero matris meæ.

Confitebor tibi, quia terribiliter magnificatus es : mirabilia opera tua, et anima mea cognoscet nimis.

Non est occultatum os meum a te, quod fecisti in occulto : et substantia mea in inferioribus terræ.

Imperfectum meum viderunt oculi tui, et in libro tuo omnes scribentur : dies formabuntur, et nemo in eis.

Mihi autem nimis honorificati sunt amici tui, Deus : nimis confortatus est principatus eorum.

Dinumerabo eos, et super arenam multiplicabuntur : exsurrexi, et adhuc sum tecum.

Si occideris, Deus, peccatores : viri sanguinum declinate a me.

Quia dicitis in cogitatione : Accipient in vanitate civitates suas.

rated from Thee, whether I ascend to Heaven or descend to Hell, whether I go forth to the rising of the morning sun, or to the darkness left by his departure in the west ; therefore I will offer up Myself as a never-ceasing Eucharist to Thee, declaring the marvellousness of Thy works in creating a New Man, after God, in righteousness and true holiness." The prophet Isaiah gave to the Church, therefore, a perpetual Antiphon to this Psalm when he said, "Behold, a Virgin shall conceive, and bear a Son, and shall call His Name Immanuel." [Isa. vii. 14.] "God with us." [Matt. i. 23.]

"But the actual fleshly Body of Christ was itself the type of His Mystical Body, the Church, and is as such continually represented in Scripture. His bodily agonies on the cross were a warning of the afflictions to which the Church should be continually exposed, always delivered unto death for Jesus' sake ; His unbroken bones betokened the undiminished strength which throughout her afflictions the Church should retain ; the blood and water

which flowed from His pierced side exhibited to view what subsequent generations cherished in the two Christian sacraments. It would be impossible, therefore, with due regard to the analogy of other Scripture-teaching, to read in the Psalm before us a prophecy of the Incarnation of Christ, and yet not to behold in it also a picture of that more spiritual Body of His, in which, and in the different members of which, His glory was to be displayed forth to the world from the period of His first to that of His second coming. . . . In secret, in the darkness of His own grave, that Church was fearfully and wonderfully made : the Corn had to fall into the ground and die ere its much fruit could be brought forth. Then, after His Resurrection from the dead, and Ascension to His Father in Heaven,—"I have awaked, and am again with Thee,"—did His new life on earth in the person of the company of His redeemed people begin. It was then, when in His own Person He had left the world and gone to the Father, that He openly contemplates both the preciousness and the number of the

The XXIX.
Day.
Morning
Prayer.
2 John 2. 10.

21 Do not I hate them, O Lord, that hate thee : and am not I grieved with those that rise up against thee ?

22 Yea, I hate them right sore : even as though they were mine enemies.

23 Try me, O God, and seek the ground of my heart : prove me, and examine my thoughts.

24 Look well if there be any way of wickedness in me : and lead me in the way everlasting.

THE CXL PSALM.

Eripe me, Domine.

DELIVER me, O Lord, from the evil man : and preserve me from the wicked man.

2 Who imagine mischief in their hearts : and stir up strife all the day long.

Rom. iii. 13.
Matt. xxii. 36.

3 They have sharpened their tongues like a serpent : adder's poison is under their lips.

4 Keep me, O Lord, from the hands of the ungodly : preserve me from the wicked men, who are purposed to overthrow my goings.

Jer. xviii. 22.

5 The proud have laid a snare for me, and spread a net abroad with cords : yea, and set traps in my way.

6 I said unto the Lord, Thou art my God : hear the voice of my prayers, O Lord.

Eph. vi. 17.

7 O Lord God, thou strength of my health : thou hast covered my head in the day of battle.

8 Let not the ungodly have his desire, O Lord : let not his mischievous imagination prosper, lest they be too proud.

9 Let the mischief of their own lips fall upon the head of them : that compass me about.

Nonne qui oderunt te, Domine, ode-ram : et super inimicos tuos tabescebam ?

Perfecto odio oderam illos : inimici facti sunt mihi.

Proba me, Deus, et scito cor meum : interroga me, et cognosce semitas meas.

Et vide, si via iniquitatis in me est : et deduc me in via æterna.

PSALMUS CXXXIX.

ERIPE me, Domine, ab homine malo : a viro iniquo eripe me. Friday, Maundy Thursd., Good Friday, Vespers. iniquo libera me

Qui cogitaverunt iniquitates in corde : malitia in corde tota die constituebant prælia.

Acuerunt linguas suas sicut serpentis : venenum aspidum sub labiis eorum.

Custodi me, Domine, de manu peccatoris : et ab hominibus iniquis eripe me. libera

Qui cogitaverunt supplantare gressus meos : absconderunt superbi laqueum mihi.

Et funes extenderunt in laqueum : pedibus meis : juxta juxta iter scandalum posuerunt mihi.

Dixi Domino, Deus meus es tu : exaudi, Domine, vocem deprecationis orationis meæ.

Domine, Domine, virtus salutis meæ : obumbrasti super caput meum in die obumbra caput belli.

Ne tradas me, Domine, a desiderio meo peccatori : cogitaverunt contra me ; ne derelinquas me, ne forte exalitentur. ne unquam exal.

Caput circuitus eorum : labor laborum ipsorum operiet eos.

friends of God, the members of His Body. Their preciousness was shown by the fulness of measure in which He poured forth His gifts upon them : their number was the Divine fulfilment of the promise originally made to Abraham, 'I will make thy seed as the dust of the earth : so that if a man can number the dust of the earth, then shall thy seed also be numbered !'

The last six verses of this Psalm illustrate what has been said respecting the imprecations in a note on the sixty-ninth Psalm 2,

1 Thrupp on the Psalms, ii. 297.

2 Page 410.

showing that the hatred of the Church towards recklessly impenitent sinners is a hatred of them as the enemies of her Lord ; a hatred, in fact, of their reckless sin, mingled with grief for them in respect to the consequences which such impenitence will bring upon their bodies and souls.

PSALM CXL.

This is also one of those Psalms of which the sixty-ninth is a type, wherein the full wickedness of opposition to Christ and His Church is set forth by the strength of the language which is used in

The XXIX.

Day.
Morning
Prayer.
Rev. xx. 2, 3. 14,
15.

Jer. xviii 18.
James i. 26.
Job xi. 2.

10 Let hot burning coals fall upon them : let them be cast into the fire, and into the pit, that they never rise up again.

11 A man full of words shall not prosper upon the earth : evil shall hunt the wicked person to overthrow him.

12 Sure I am that the Lord will avenge the poor : and maintain the cause of the helpless.

Matt. xiii. 43. 13 The righteous also shall give thanks unto thy Name : and the just shall continue in thy sight.

THE CXXI PSALM.

Domine, clamavi.

LORD, I call upon thee, haste thee unto me : and consider my voice, when I cry unto thee.

2 Let my prayer be set forth in thy sight as the incense : and let the lifting up of my hands be an evening sacrifice.

Luke i. 10.
Rev. v. 8. viii. 3.
1 Kings xviii. 36.
Matt. xxvii. 46.

3 Set a watch, O Lord, before my mouth : and keep the door of my lips.

4 O let not mine heart be inclined to any evil thing : let me not be occupied in ungodly works, with the men that work wickedness, lest I eat of such things as please them.

Zech. xiii. 6, 7. 5 Let the righteous rather smite me friendly : and reprove me.

6 But let not their precious balms break my head : yea, I will pray yet against their wickedness.

7 Let their judges be overthrown in stony places : that they may hear my words, for they are sweet.

Cadent super eos carbones, in ignem carbones ignis deicies eos : in miseriis non subsistent.

Vir linguosus non dirigetur in terra : virum injustum mala capient in interitu.

Cognovi quia faciet Dominus iudicium inopis : et vindictam pauperum.

Veruntamen iusti confitebuntur Nomini tuo : et habitabunt recti cum vultu tuo.

PSALMUS CXL.

DOMINE, clamavi ad te, exaudi me : intende voci meæ, cum clamavero ad te. Friday, Maundy Thursd., Good Friday, Vespers. voci orationis meæ

Dirigatur oratio mea sicut incensum in conspectu tuo : elevatio manuum mearum sacrificium vespertinum.

Pone, Domine, custodiam ori meo : et ostium circumstantiæ labiis meis.

Non declines cor meum in verba malitiæ : ad excusandas excusationes in peccatis. Ut non . . . in verbum malum

Cum hominibus operantibus iniquitatem : et non communicabo cum electis eorum. combinabor

Corripiet me justus in misericordia, et increpabit me : oleum autem peccatoris non impinguet caput meum.

Quoniam adhuc et oratio mea in beneplacitis eorum : absorpti sunt juncti petrae iudices eorum. continuati petrae

Audient verba mea, quoniam potuerunt : sicut crassitudo terræ erupta est super terram.

its condemnation. "The evil man," and "the wicked man," who "have sharpened their tongues like a serpent," the "ungodly," and the "proud," are all representative terms, signifying, in their most extreme sense, that Evil One whom St. Paul calls "the Wicked," the "old Serpent," whose minister is Antichrist. From the temptation of the first Adam in Paradise to the Temptation of the Second Adam in the wilderness, and thence onward in all ages of the Church until the last great Day, this Evil One is imagining mischief against Christ and His Mystical Body, so that the prayer must ever go up, "Deliver us from the Evil," until Satan and his ministers have been cast into the "bottomless pit," among the "hot burning coals" of God's never-ending displeasure.

Then the event will show that God has surely avenged the Poor : the Mystical Body of the RIGHTEOUS shall give thanks to His Name, and shall continue in His Presence for ever.

PSALM CXXI.

This is the cry of the Lord and of His Church under suffering from the first and the last persecutors. When the Lamb of God was offered up in the evening of the world's duration, and on the evening of the first Good Friday, He became the true Evening Sacrifice, Whose very attitude was that then used in prayer, a lifting up of His hands, and spreading them forth as when one spreadeth forth his hands to swim. All the day long did He stretch forth His hands to a gainsaying people, yet not in vain, for it was all the day long also in intercession with His Father. And although there was a supernatural darkness over body and soul for a time, the incense of His supplication arose before the throne, and when the Evening Sacrifice had been offered, the prophecy was fulfilled, "It shall come to pass that at evening time it shall be light." [Zech. xiv. 7.]

The XXIX. 8 Our bones lie scattered before the
 • Day. pit : like as when one breaketh and
Morning heweth wood upon the earth.
Prayer.
 1 Sam. xxii. 16—
 19. 9 But mine eyes look unto thee, O
 Ezek. xxxvii. 2. Lord God : in thee is my trust, O
 Luke xxi. 28. cast not out my soul.
 Jer. xxxi. 15.
 Isa. lxvi. 14.
 Job xviii. 8—10. 10 Keep me from the snare that
 they have laid for me : and from the
 traps of the wicked doers.
 11 Let the ungodly fall into their
 own nets together : and let me ever
 escape them.

THE CXLII PSALM.

Voce mea ad Dominum.

Evening I CRIED unto the Lord with my
Prayer. voice : yea, even unto the Lord
 Ps. lxxvii. 1—3. did I make my supplication.
 2 I poured out my complaints be-
 fore him : and shewed him of my
 trouble.
 Matt. xxvii. 38—
 44. 3 When my spirit was in heaviness,
 thou knewest my path : in the way
 wherein I walked have they privily
 laid a snare for me.
 Matt. xxvi. 56.
 Luke xxiii. 49. 4 I looked also upon my right
 hand : and saw there was no man
 that would know me.
 Matt. viii. 20. 5 I had no place to flee unto : and
 no man cared for my soul.
 Luke xxiii. 46. 6 I cried unto thee, O Lord, and
 said : Thou art my hope, and my
 portion in the land of the living.
 Isa. lxiii. 9. 7 Consider my complaint : for I
 am brought very low.
 8 O deliver me from my persecutors :
 for they are too strong for me.
 1 Sam. xxii. 1.
 Isa. liii. 11. 9 Bring my soul out of prison, that
 I may give thanks unto thy Name :
 which thing if thou wilt grant me,
 then shall the righteous resort unto
 my company.

Dissipata sunt omnia ossa nostra *sunt ossa*
 secus infernum : quia ad te, Domine,
 Domine, oculi mei ; in te speravi, non
 auferas animam meam.

Custodi me a laqueo quem statue-
 runt mihi : et a scandalis operantium *operantibus*
 iniquitatem.

Cadent in retinaculo ejus peccatores :
 singulariter sum ego donec transeam.

PSALMUS CXLI.

VOCE mea ad Dominum clamavi : *Friday, Maundy*
Thursd., Good
 voce mea ad Dominum depre- *Friday, Vespers.*
 catus sum.
 Effundo in conspectu ejus oratio-
 nem meam : et tribulationem meam
 ante ipsum pronuntio.
 In deficiendo ex me spiritum meum :
 et tu cognovisti semitas meas.
 In via hac qua ambulabam : ab-
 sconderunt laqueum mihi.
 Considerabam ad dexteram, et vide-
 bam : et non erat qui cognosceret me.
 Periiit fuga a me : et non est qui
 requirat animam meam.
 Clamavi ad te, Domine ; dixi, Tu es
 spes mea : portio mea in terra viven-
 tium.
 Intende ad deprecationem meam : *in orationem*
 quia humiliatus sum nimis.
 Libera me a persequentibus me :
 quia confortati sunt super me.
 Educ de custodia animam meam ad *in carceres*
 confitendum Nomini tuo : me expec-
 tant justi, donec retribuas mihi.

For the Church this is a continual hymn of exposition upon the words of Christ respecting the troubles of the last days : "In your patience possess ye your souls" . . . "when these things begin to come to pass, then look up and lift up your heads, for your redemption draweth nigh." [Luke xxi. 19. 28.] It is better for the Church and for each particular member of Christ to suffer chastisement for a season in the mercy of a righteous Father, than to gain a temporary prosperity by partaking of the "dainty and goodly things" of Babylon and Antichrist, and so fall into the snare and the net from which there is no escape. [Rev. xvii. and xviii.]

PSALM CXLII.

When David thus poured out his complaints to the Lord, and showed Him of his trouble, he prefigured the holy Son of David of Whom it is said, "In all their affliction He was afflicted." It is supposed that this Psalm was sung by David when he was in the cave of Adullam, as was also the fifty-seventh¹ : and if so, the circumstances in which he was may have contributed their typical character to it, since it evidently presents to us the Voice

¹ See p. 393.
 3 U 2

THE CXLIII PSALM.

Domine, exaudi.

The XXIX.

Day.
Evening*Prayer.*
Ash-Wednesday,
Evensong,
Penitential
Psalm.
Job ix. 32.
xxii. 4.

HEAR my prayer, O Lord, and consider my desire : hearken unto me for thy truth and righteousness' sake.

2 And enter not into judgement with thy servant : for in thy sight shall no man living be justified.

3 For the enemy hath persecuted my soul ; he hath smitten my life down to the ground : he hath laid me in the darkness, as the men that have been long dead.

4 Therefore is my spirit vexed within me : and my heart within me is desolate.

5 Yet do I remember the time past ; I muse upon all thy works : yea, I exercise myself in the works of thy hands.

John xix. 28.

6 I stretch forth my hands unto thee : my soul gaspeth unto thee as a thirsty land.

Matt. xxvii 46.
Ps. xxviii 1.
lxxxviii. 3.

7 Hear me, O Lord, and that soon, for my spirit waxeth faint : hide not thy face from me, lest I be like unto them that go down into the pit.

Luke xxiii. 46.

8 O let me hear thy lovingkindness betimes in the morning, for in thee is my trust : shew thou me the way that I should walk in, for I lift up my soul unto thee.

Ps. xxxi. 22.

9 Deliver me, O Lord, from mine enemies : for I flee unto thee to hide me.

10 Teach me to do the thing that pleaseth thee, for thou art my God : let thy loving Spirit lead me forth into the land of righteousness.

PSALMUS CXLII.

DOMINE, exaudi orationem meam ; Friday Lauds.
auribus percipe obsecrationem meam : in veritate tua exaudi me, in tua justitia.

Et non intres in iudicium cum servo tuo : quia non justificabitur in conspectu tuo omnis vivens.

Quia persecutus est inimicus animam meam : humiliavit in terra vitam meam.

Collocavit me in obscuris sicut mortuos sæculi : et anxius est super me spiritus meus, in me turbatum est cor meum.

Memor fui dierum antiquorum, meditatus sum in omnibus operibus tuis : in factis manuum tuarum meditabar.

Expandi manus meas ad te : anima mea sicut terra sine aqua tibi.

Velociter exaudi me, Domine : defecit spiritus meus.

Non avertas faciem tuam a me : et similis ero descendentibus in lacum.

Audiam fac mihi mane misericordiam tuam : quia in te speravi. speravi Domine

Notam fac mihi viam in qua ambulem : quia ad te levavi animam meam. ad te Domine

Eripe me de inimicis meis, Domine ; ad te confugi : doce me facere voluntatem tuam, quia Deus meus es tu.

Spiritus tuus bonus deducet me in in via recta terram rectam : propter Nomen tuum, Domine, vivificabis me in æquitate tua.

of Christ crying unto the Lord out of that darkness which was to Him as the "prison" of sinners¹.

Thus, from His Cross, and in the greatest depth of His sorrows, the suffering Saviour cries unto the Lord, beseeching Him not to forsake Him, but to receive His Spirit. And in that darkest hour even, He can see of the travail of His soul and be satisfied, knowing that when that soul is brought out of prison, the great Eucharistic Sacrifice for all the world will have been offered, and that a vast congregation of those made righteous by it will gather to their Saviour's company, in His Mystical Body.

So, also, has the Church often been partaker in the sufferings of Christ to such an extent as to be able to take up the words spoken by Him in a great degree of their fulness. And as the Head was delivered from His persecutors to give thanks to God,

in like manner will the faithfulness of His Church prevail, in the mercy of God, to her final rescue from sorrow, however strong her persecutors may be.

PSALM CXLIIII.

This is the seventh, and last, of the Penitential Psalms. Like the preceding Psalm, it is the Voice of Christ speaking to us out of the anguish of the Cross, when God's ancient word was fulfilled by the Serpent bruising the heel of the Woman's Seed, and laying Him in the darkness as the men that have been long dead in the grave of their sin. From that Cross, stretching forth His wounded hands in supplication, He prayed to God as the One Penitent on Whom all the sins of mankind were gathered together, and Whose Voice was bewailing them in such tones of sorrow as none else could use, since only the Innocent, "made sin for us," could so feel the awful burden.

¹ See note on Ps. lxxxviii. p. 440.

The XXX.
Day.
Evening
Prayer.

11 Quicken me, O Lord, for thy Name's sake : and for thy righteousness' sake bring my soul out of trouble.

12 And of thy goodness slay mine enemies : and destroy all them that vex my soul ; for I am thy servant.

THE CXLIV PSALM.

Benedictus Dominus.

The XXX. Day.
Morning
Prayer.

2 Sam. xxii. 35.
40.

2 Sam. xxii. 2, 3.

BLESSED be the Lord my strength : who teacheth my hands to war, and my fingers to fight ;

2 My hope and my fortress, my castle and deliverer, my defender in whom I trust : who subdueth my people that is under me.

Ps. viii. 4.
Heb. ii. 6.

3 Lord, what is man, that thou hast such respect unto him : or the son of man, that thou so regardest him ?

4 Man is like a thing of nought : his time passeth away like a shadow.

5 Bow thy heavens, O Lord, and come down : touch the mountains, and they shall smoke.

2 Sam. xxii. 15.
Matt. xxviii. 2-4.
Luke xvii. 24.

6 Cast forth thy lightning, and tear them : shoot out thine arrows, and consume them.

2 Sam. xxii. 45.

7 Send down thine hand from above : deliver me, and take me out of the great waters, from the hand of strange children ;

8 Whose mouth talketh of vanity : and their right hand is a right hand of wickedness.

9 I will sing a new song unto thee, O God : and sing praises unto thee upon a ten-stringed lute.

Educes de tribulatione animam meam : et in misericordia tua disperdes omnes inimicos meos.

Et perdes omnes qui tribulant animam meam : quoniam ego servus tuus sum.

PSALMUS CXLIII.

BENEDICTUS Dominus Deus Sat. Vespers.

meus, qui docet manus meas ad prælium : et digitos meos ad bellum.

Misericordia mea et refugium meum : susceptor meus et liberator meus.

Protector meus, et in ipso speravi : qui subdit populum meum sub me.

*subiciens populos
sub me*

Domine, quid est homo, quia innotuisti ei ? aut filius hominis, quia reputas eum ?

Homo vanitati similis factus est : dies ejus sicut umbra prætereunt.

Domine, inclina cælos tuos, et descende : tange montes, et fumigabunt.

Fulgura coruscationem, et dissipabis eos : emitte sagittas tuas, et conturbabis eos. *Corusca coruscationes tuas*

Emitte manum tuam de alto ; eripe me, et libera me de aquis multis : et de manu filiorum alienorum.

Quorum os locutum est vanitatem : et dextera eorum dextera iniquitatis.

Deus, canticum novum cantabo tibi : in psalterio decachordo psallam tibi

But the words of our holy Saviour's vicarious penitence are become a fountain of penitential expression for those whose sins are their own. The Enemy has persecuted their soul, smitten their spiritual life down to the ground, and laid them in the darkness of that sinful state in which the Vision of God is faint or lost. Then, in the words of their Saviour, they lay their vexed spirits and desolate hearts at the footstool of a merciful God, and stretch forth their hands to Him, beseeching Him not to hide His face from them for ever, but to let them hear His loving-kindness in the morning of the resurrection : to quicken their sin-stricken souls in this life, that they may arise to everlasting life in "the land of righteousness."

PSALM CXLIV.

David here prefigures the Captain of our salvation. So among his last words, when he said, "Thou hast girded me with strength unto the battle," he added such expressions regarding the future as could only be true of his Lord : "Thou hast also delivered me

from the strivings of my people ; Thou hast kept me to be the head of the heathen : a people which I knew not shall serve me." David's conflict with the lion, the bear, and the Philistine champion, were all symbolical of the contest between Christ and the powers of evil, in the days of His flesh, and in the life of His Mystical Body. With the shepherd's staff of His Incarnate Body, and the "five smooth stones" of His wounds, His hands were taught to war and His fingers to fight, coming before the powers of evil not with sword and spear, but in the Name of the Lord of hosts.

This Psalm thus points to our Lord's work of victory by means of the Incarnation. "Man is like a thing of nought," but the Son of God became the Son of Man, and raised human nature to its former place in the harmony of God's Kingdom. The Hand was sent down from above, and delivered our nature from the hand of the oppressor, lifting it out of the great waters in which it was almost overwhelmed. The "everlasting arms" supported it, and the "right hand of wickedness" lost its power. Then was

The XXX. Day.
Morning
Prayer.
Rev. xix. 11—16.

10 Thou hast given victory unto kings : and hast delivered David thy servant from the peril of the sword.

11 Save me, and deliver me from the hand of strange children : whose mouth talketh of vanity, and their right hand is a right hand of iniquity.

Eph. ii. 20—22.
1 Pet. ii. 4, 5.

12 That our sons may grow up as the young plants : and that our daughters may be as the polished corners of the temple.

Matt. iii. 12.
John x. 1—16.
Heb. xiii. 20.

13 That our garners may be full and plenteous with all manner of store : that our sheep may bring forth thousands and ten thousands in our streets.

1 Cor. ix. 9, 10.
1 Tim. v. 18.

14 That our oxen may be strong to labour, that there be no decay : no leading into captivity, and no complaining in our streets.

15 Happy are the people that are in such a case : yea, blessed are the people who have the Lord for their God.

THE CXLV PSALM.

Exaltabo te, Deus.

Whitsunday,
Evensong,
Commemoration
of Founders
and Benefac-
tors.

I WILL magnify thee, O God, my King : and I will praise thy Name for ever and ever.

2 Every day will I give thanks unto thee : and praise thy Name for ever and ever.

3 Great is the Lord, and marvellous, worthy to be praised : there is no end of his greatness.

4 One generation shall praise thy works unto another : and declare thy power.

5 As for me, I will be talking of thy worship : thy glory, thy praise, and wondrous works ;

Qui das salutem regibus : qui re- *liberas*
demisti David servum tuum de gladio maligno, eripe me :

Et erue me de manu filiorum alieno- *et libera me de*
rum, quorum os locutum est vanitatem : *aquis multis et*
et dextera eorum dextera iniquitatis. *de manu*

Quorum filii sicut novellæ planta- *novella planta-*
tiones : in juventute sua. *tionis stabilitas*

Filiæ eorum compositæ : circumor-
natae ut similitudo templi.

Promptuaria eorum plena : eruc-
tantia ex hoc in illud.

Oves eorum fœtosæ, abundantes in
egressibus suis : boves eorum crassæ. *itineribus*

Non est ruina maceriæ, neque trans-
itus : neque clamor in plateis eorum.

Beatum dixerunt populum, cui hæc
sunt : beatus populus cujus Dominus
Deus ejus.

PSALMUS CXLIV.

EXALTABO te Deus meus Rex : *Sat. Vespers.*
Et benedicam Nomini tuo in *Christmas,*
sæculum, et in sæculum sæculi. *1st Vespers.*
Lauds of the de-
parted.
in æternum et

Per singulos dies benedicam tibi :
et laudabo Nomèn tuum in sæculum,
et in sæculum sæculi.

Magnus Dominus, et laudabilis
nimis : et magnitudinis ejus non est
finis.

Generatio et generatio laudabit
opera tua : et potentiam tuam pro-
nuntiabunt.

Magnificentiam gloriæ sanctitatis *majestatis tuæ et*
tuæ loquentur : et mirabilia tua nar- *sanctitatem*
rabunt.

sung the "new song" of the Son of Man's triumph, a song of the victory which God had given to His anointed, and of the mercy of His Providence which had kept the true David from the peril of the Evil One's sword.

Out of that victory sprung the Church of the Redeemer, "the Temple of His Body" in which the children of God are built up as "living stones," and "polished corners," "built upon the foundation of the Apostles and Prophets, Jesus Christ Himself being the Chief Corner Stone ; in Whom all the building fitly framed together, groweth unto an holy temple in the Lord. In Whom ye also are builded together for an habitation of God, through the Spirit." Out of that victory sprung the sacramental abundance of the Church, by which myriads of souls are gathered into the heavenly garner, the flock of Christ's fold multiplied by thousands and ten thousands in the streets of the New Jerusalem, and the servants of God who wear the yoke of the priesthood endowed

with ministerial ability [2 Cor. iii. 6], that they may be strong to labour in the grace-giving work of their Master.

PSALM CXLV.¹

This is entitled "David's Psalm of praise," and it is thought by some that the title belongs to the whole final series, of which this is the commencement. Literally it is a hymn praising the Lord for His works of Creation, but mystically it praises Him for all His marvellous works in the redemption and salvation of mankind.

For these merciful works of our Lord Jesus Christ the Church already sings by anticipation "the song of Moses the servant of God, and the song of the Lamb, saying, Great and marvellous are

¹ This is an alphabet Psalm, one letter being omitted. The fifteenth verse, and perhaps the whole Psalm, was used at the celebration of the Holy Communion in the time of St. Chrysostom.

The XXX. Day. <i>Morning Prayer.</i> Rev. xv. 3.	6 So that men shall speak of the might of thy marvellous acts : and I will also tell of thy greatness.	Et virtutem terribilium tuorum dicent : et magnitudinem tuam nar- rabunt.
	7 The memorial of thine abundant kindness shall be shewed : and men shall sing of thy righteousness.	Memoriam abundantiae suavitatis <i>Memoria</i> tuae eructabunt : et justitia tua ex- sultabunt.
Exod. xxxiv. 6.	8 The Lord is gracious, and merci- ful : long-suffering, and of great goodness.	Miserator et misericors Dominus : patiens et multum misericors.
	9 The Lord is loving unto every man : and his mercy is over all his works.	Suavis Dominus universis : et mise- rationes ejus super omnia opera ejus.
Rev. v. 13. Job xxxviii. 7.	10 All thy works praise thee, O Lord : and thy saints give thanks unto thee.	Confiteantur tibi, Domine, omnia opera tua : et sancti tui benedicant tibi.
Luke ix. 20. 31.	11 They shew the glory of thy kingdom : and talk of thy power ;	Gloriam regni tui dicent : et po- tentiam tuam loquentur.
	12 That thy power, thy glory, and mightiness of thy kingdom : might be known unto men.	Ut notam faciant filiis hominum potentiam tuam : et gloriam magni- ficentiae regni tui.
Dan. ii. 44. vi. 26.	13 Thy kingdom is an everlasting kingdom : and thy dominion endureth throughout all ages.	Regnum tuum, regnum omnium tuum <i>Domine</i> saeculorum : et dominatio tua in omni generatione et generationem.
	14 The Lord upholdeth all such as fall : and lifteth up all those that are down.	Fidelis Dominus in omnibus verbis <i>in verbis</i> suis : et sanctus in omnibus operibus suis.
Heb. xii. 12. James iv. 10.	15 The eyes of all wait upon thee, O Lord : and thou givest them their meat in due season.	Allevat Dominus omnes qui cor- ruunt : et erigit omnes elisos.
John vi. 51. Rev. xxii. 2.	16 Thou openest thine hand : and fillest all things living with plenteous- ness.	Oculi omnium in te sperant, Do- mine : et tu das escam illorum in tem- pore opportuno.
	17 The Lord is righteous in all his ways : and holy in all his works.	Aperis tu manum tuam : et imples omne animal benedictione.
James iv. 8.	18 The Lord is nigh unto all them that call upon him : yea, all such as call upon him faithfully.	Justus Dominus in omnibus viis suis : et sanctus in omnibus operibus suis.
	19 He will fulfil the desire of them that fear him : he also will hear their cry, and will help them.	Prope est Dominus omnibus invo- <i>Prope est Dominus</i> cantibus eum : omnibus invocantibus <i>omnibus invo-</i> eum in veritate. <i>cantibus eum in</i> <i>veritate</i>
Luke xxi. 18.	20 The Lord preserveth all them that love him : but scattereth abroad all the ungodly.	Voluntatem timentium se faciet : et deprecationem eorum exaudiet, et <i>et orationes eorum</i> salvos faciet eos.
		Custodit Dominus omnes diligentes se : et omnes peccatores disperdet.

Thy works, Lord God Almighty; just and true are Thy ways, Thou King of Saints;" praising Him day by day for these in all her Psalms and Hymns and spiritual songs. One generation takes up the strain from its forerunner, and the song goes up unceasingly to the throne from the choirs of Cathedrals, parish churches, and religious houses, "We praise Thee, O God; we acknowledge Thee to be the Lord. The holy Church throughout all the world doth acknowledge Thee; the Father of an infinite Majesty; Thine honourable, true, and only Son; also the Holy Ghost the Comforter."

And with the voice of the redeemed Church goes up the voice of all the works of God, each in its appointed and orderly round setting forth His praise Who created it. "And every creature which is in Heaven, and on the earth, and under the earth, and such as are in the sea, and all that are in them, heard I saying, Blessing, and honour, and glory, and power, be unto Him that sitteth upon the throne, and unto the Lamb for ever and ever."

And as in the natural, so in the spiritual world, the eyes of all wait upon the Lord the Holy Ghost, the Giver of Life, that He may give them their meat in due season. Already does the Life-

The XXX. Day.
Morning
Prayer.
Rev. xiv. 7.

21 My mouth shall speak the praise of the Lord : and let all flesh give thanks unto his holy Name for ever and ever.

THE CXLVI PSALM.

Lauda, anima mea.

Commemoration
of Founders
and Benefac-
tors.
Windsor Obiit
Sunday.

PRaise the Lord, O my soul ; while I live will I praise the Lord : yea, as long as I have any being, I will sing praises unto my God.

Isa. ii. 22.

2 O put not your trust in princes, nor in any child of man : for there is no help in them.

Gen. ii. 7.
iii. 19.
Ps. civ. 29.

3 For when the breath of man goeth forth he shall turn again to his earth : and then all his thoughts perish.

4 Blessed is he that hath the God of Jacob for his help : and whose hope is in the Lord his God ;

Col. i. 16, 17.

5 Who made heaven and earth, the sea, and all that therein is : who keepeth his promise for ever ;

6 Who helpeth them to right that suffer wrong : who feedeth the hungry.

Isa. ix. 2.
xxxv. 5, 6.
lxi. 1.

7 The Lord looseth men out of prison : the Lord giveth sight to the blind.

Luke iv. 18, 21.

8 The Lord helpeth them that are fallen : the Lord careth for the righteous.

9 The Lord careth for the stranger ; he defendeth the fatherless and widow : as for the way of the ungodly, he turneth it upside down.

Isa. xxvi. 4.

10 The Lord thy God, O Sion, shall be King for evermore : and throughout all generations.

THE CXLVII PSALM.

Laudate Dominum.

Evening
Prayer.
Commemoration
of Founders
and Benefac-
tors.
Windsor Obiit
Sunday.

O PRAISE the Lord, for it is a good thing to sing praises unto our God : yea, a joyful and pleasant thing it is to be thankful.

Laudationem Domini loquetur os meum : et benedicat omnis caro Nobis sancto ejus in sæculum, et in in æternum et sæculum sæculi.

PSALMUS CXLV.

LAUDA, anima mea, Dominum ; laudabo Dominum in vita mea : psallam Deo meo quandiu fueŕo.

Sat. Vespers.
Christmas,
1st Vespers.
Vigils of the de-
parted.

Nolite confidere in principibus : in filiis hominum, in quibus non est salus.

Exibit spiritus ejus, et revertetur in terram suam : in illa die peribunt omnes cogitationes eorum.

Beatus cujus Deus. Jacob adjutor ejus, spes ejus in Domino Deo ipsius, qui fecit cœlum et terram : mare et omnia quæ in eis sunt.

Qui custodit veritatem in sæculum ; facit judicium injuriam patientibus : dat escam esurientibus.

Dominus solvit compeditos : Dominus illuminat cæcos.

Dominus erigit elisos : Dominus dirigigit justos.

Dominus custodit advenas ; pupillum et viduam suscipiet : et vias peccatorum disperdet.

viam peccatorum
exterminabit

Regnabit Dominus in sæcula ; Deus tuus, Sion : in generatione et generationem.

in æternum
in sæculum sæculi

PSALMUS CXLVI.

LAUDATE Dominum, quoniam bonus est psalmus : Deo nostro sit jucunda decoraque laudatio.

Sat. Vespers.
Christmas,
1st Vespers.
nostro jucunda sit
laudatio

giver bestow on them Corn and Wine for sacramental life, the Bread which came down from Heaven, and the blood of the True Vine : hereafter will He provide for them the Tree of Life in the midst of the street of the New Jerusalem and on either side of the river of life, which shall bear "twelve manner of fruits, and yield her fruit every month," for the perpetual invigoration of His saints.

PSALM CXLVI.

This is a song of the Church when at rest and peace, able to lift up her soul without any sorrow in Hallelujahs to her King : and blessing Him Who has wrought her deliverance. "Trust ye in the Lord for ever ; for in the Lord Jehovah is everlasting strength."

The XXX. Day. 2 The Lord doth build up Jerusa-
Evening lem : and gather together the out-
Prayer. casts of Israel.

Isa. xi. 12. lvi. 8.
John xi. 52.
Isa. lxi. 1.
Luke iv. 18. 21.

3 He healeth those that are broken
in heart : and giveth medicine to heal
their sickness.

Isa. xl. 26.
John x. 3.

4 He telleth the number of the
stars : and calleth them all by their
names,

5 Great is our Lord, and great is
his power : yea, and his wisdom is
infinite.

6 The Lord setteth up the meek :
and bringeth the ungodly down to the
ground.

7 O sing unto the Lord with thanks-
giving : sing praises upon the harp
unto our God ;

Ps. ciii. 13, 14.

8 Who covereth the heaven with
clouds, and prepareth rain for the
earth : and maketh the grass to grow
upon the mountains, and herb for the
use of men ;

Job xxxviii. 41.
Luke xii. 24.

9 Who giveth fodder unto the cat-
tle : and feedeth the young ravens
that call upon him.

10 He hath no pleasure in the
strength of an horse : neither delight-
eth he in any man's legs.

11 But the Lord's delight is in
them that fear him : and put their
trust in his mercy.

12 Praise the Lord, O Jerusalem :
praise thy God, O Sion.

Rev. xxi. 12.

13 For he hath made fast the bars
of thy gates : and hath blessed thy
children within thee.

Ædificans Hierusalem Dominus :
dispersiones Israëlis congregabit. *congregans*

Qui sanat contritos corde : et alligat
contritiones eorum.

Qui numerat multitudinem stella-
rum : et omnibus-eis nomina vocat.

Magnus Dominus noster, et magna
virtus ejus : et sapientiæ ejus non est
numerus.

Suscipiens mansuetos Dominus : hu-
milians autem peccatores usque ad
terram.

Præcinite Domino in confessione : *Incipite*
psallite Deo nostro in cithara.

Qui operit cælum nubibus : et parat
terræ pluviam.

Qui producit in montibus fœnum :
et herbam servituti hominum.

Qui dat jumentis escam ipsorum :
et pullis corvorum invocantibus eum.

Non in fortitudine equi voluntatem *in viribus*
habebit : nec in tibiis viri beneplaci-
tum erit ei.

Beneplacitum est Domino super ti-
mentes eum : et in eis qui sperant
super misericordia ejus.

PSALMUS CXLVII.

LAUDA, Hierusalem, Dominum : *Sat. Vespers.*
Lauda Deum tuum, Sion. *Christmas,*
1st Vespers.

Quoniam confortavit seras portarum
tuarum : benedixit filiis tuis in te.

Christ is, therefore, praised as the Creator of the natural and the spiritual world ; of the heaven, which is the Church above in glory ; of the earth, which is the Church Militant ; of the sea, which is the world without, into which the Church casts her net for a draught at her Master's word. Thus He is praised in terms founded on the prophecy of Isaiah which He Himself expounded when He said, "This day is this Scripture fulfilled in your ears :—" "The Spirit of the Lord is upon Me, because He hath anointed Me to preach the Gospel to the poor ; He hath sent Me to heal the broken-hearted, to preach deliverance to the captives, and recovering of sight to the blind, to set at liberty them that are bruised, to preach the acceptable year of the Lord." Blessed they who have this Helper for their own : they shall sing His praises as long as they have any being : and declare Him to be their King for evermore, and throughout all generations.

PSALM CXLVII.

The song of joy and thanksgiving is continued, the subject being the edification of the Church of God, the gathering in of

the Gentiles, the healing work of sacramental grace. So in the Church Militant does Christ gather together in one the children of God that are scattered abroad, that there may be one fold and one Shepherd ; so in the Church Triumphant will His elect be gathered together from the four winds of heaven : and though no man could number the spiritual seed of Abraham more than he could count the stars, yet the Good Shepherd knows all His sheep, and "calleth His own by name, and leadeth them out." Thus the Lord setteth up Him Who was "meek and lowly of heart" in an eternal kingdom, and bringeth the ungodly, Satan and his evil ministers, down to the ground in an everlasting destruction.

Throughout this Psalm, as in many others, the blessings of supernatural grace are indicated by reference to those of natural provision. The clouds and rain represent the overshadowing abundance of the dew of the Holy Spirit, causing the sacramental food of God's children to grow upon the mountain of His Church, the City set on an hill, the "great and holy mountain" where the prophet saw "the holy Jerusalem descending out

The XXX. Day.
Evening
Prayer.
Isa. ii. 4.

14 He maketh peace in thy borders :
and filleth thee with the flour of wheat.

15 He sendeth forth his command-
ment upon earth : and his word run-
neth very swiftly.

Job xxxvii. 6.
Rev. i. 14.

16 He giveth snow like wool : and
scattereth the hoar-frost like ashes.

17 He casteth forth his ice like
morsels : who is able to abide his
frost ?

18 He sendeth out his word, and
melteth them : he bloweth with his
wind, and the waters flow.

19 He sheweth his word unto
Jacob : his statutes and ordinances
unto Israel.

20 He hath not dealt so with any
nation : neither have the heathen
knowledge of his laws.

THE CXLVIII PSALM.

Laudate Dominum.

Rev. v. 13.

O PRAISE the Lord of heaven :
praise him in the height.

2 Praise him, all ye angels of his :
praise him, all his host.

3 Praise him, sun and moon : praise
him, all ye stars and light.

4 Praise him, all ye heavens : and
ye waters that are above the heavens.

5 Let them praise the Name of the
Lord : for he spake the word, and
they were made ; he commanded, and
they were created.

6 He hath made them fast for ever
and ever : he hath given them a law
which shall not be broken.

7 Praise the Lord upon earth : ye
dragons, and all deeps ;

Qui posuit fines tuos pacem : et
adipe frumenti satiat te.

Qui emittit eloquium suum terræ :
velociter currit sermo ejus.

Qui dat nivem sicut lanam : nebu-
lam sicut cinerem spargit.

Mittit crystallum suam sicut buc- sicut frustra panis
cellas : ante faciem frigoris ejus quis
sustinebit ? subsistit

Emittet verbum suum, et liquefa-
ciet ea : flabit spiritus ejus, et fluent flavit
aquæ.

Qui annuntiat verbum suum Jacob :
justitias et judicia sua Israël.

Non fecit taliter omni nationi : et
judicia sua non manifestavit eis.

PSALMUS CXLVIII.

LAUDATE Dominum de cœlis : Lauds, ferial and
festival.
laudate eum in excelsis. Lauds of the de-
parted.

Laudate eum, omnes angeli ejus :
laudate eum, omnes virtutes ejus.

Laudate eum, sol et luna : laudate
eum, omnes stellæ et lumen.

Laudate eum, cœli cœlorum : et
aquæ omnes quæ super cœlos sunt, aquæ quæ
laudent Nomen Domini.

Quia ipse dixit, et facta sunt : ipse
mandavit, et creata sunt.

Statuit ea in æternum, et in sæcu-
lum sæculi : præceptum posuit, et non
præteribit.

Laudate Dominum de terra : draco-
nes, et omnes abyssi ;

of Heaven from God." The "flour of wheat" with which Sion is filled when He maketh peace in her borders, signifies the Bread of Heaven which the Prince of Peace gives in His City of Peace.

There are other allusions, moreover, which can scarcely be dissociated from our Lord, as when His word running very swiftly reminds us of the eternal WORD, the Sun of righteousness, who goeth forth as a giant to run his course : or as when the giving of snow like wool recalls Him of whom it is said that "His head and His hairs were white like wool, as white as snow."

Thus we look, in this hymn of praise, to our Lord as the Source of all grace and strength in that City, the bars of whose gates He has made fast by sure foundation on Himself the Rock. No natural powers,—such as animal strength,—can win a place in that City, but only the fear of the Lord, and trust in His mercy. There he deals mercifully and graciously with the nation whom He has chosen to Himself to be His inheritance, giving them

peace in their borders, and filling them with His grace, and showing them His Word.

PSALM CXLVIII.

The three concluding Psalms of the Psalter have always been specially connected together in the mind of the Church, as *Alvos*, or "Lauds." They proclaim the final progress of the Church "from glory to glory," in the New Creation, the Resurrection, and the bliss of Heaven.

This, the first of the three, calls upon all created things to join their voices with the Church in Heaven and earth and praise the Lord of all, and is expanded in the Song of the Three Holy Children, the "Benedicite omnia Opera" of Morning Prayer. The mystery of a sympathy between all the works of God, animate and inanimate, is frequently referred to in the Psalms and elsewhere. When the Lord answered Job out of the whirlwind, He

The XXX. Day. 8 Fire and hail, snow and vapours :
Evening Prayer. wind and storm, fulfilling his word ;
 Isa. lv. 12. 9 Mountains and all hills : fruitful
 trees and all cedars ;
 10 Beasts and all cattle : worms
 and feathered fowls ;
 11 Kings of the earth and all people :
 princes and all judges of the world ;
 Rev. xix. 5. 12 Young men and maidens, old
 men and children, praise the Name of
 the Lord : for his Name only is ex-
 cellent, and his praise above heaven
 and earth.
 Luke i. 69. 13 He shall exalt the horn of his
 Rev. xxii. 3. people ; all his saints shall praise him :
 even the children of Israel, even the
 people that serveth him.

THE CXLIX PSALM.

Cantate Domino.

Rev. xix. 1. **O** SING unto the Lord a new song :
 Eph. i. 1. let the congregation of saints
 praise him.
 Matt. xxi. 5. 2 Let Israel rejoice in him that
 Cant. i. 4. made him : and let the children of
 Sion be joyful in their King.
 3 Let them praise his Name in the
 dance : let them sing praises unto him
 with tabret and harp.
 4 For the Lord hath pleasure in his
 people : and helpeth the meek-hearted.
 Isa. xxvi. 19. 5 Let the saints be joyful with
 glory : let them rejoice in their beds.
 Rev. xix. 15. 6 Let the praises of God be in their
 mouth : and a two-edged sword in their
 hands ;
 1 Cor. vi. 2. 7 To be avenged of the heathen :
 and to rebuke the people ;
 8 To bind their kings in chains :
 and their nobles with links of iron.
 9 That they may be avenged of
 them, as it is written : Such honour
 have all his saints.

Ignis, grando, nix, glacies, spiritus
 procellarum : quæ faciunt verbum ejus.
 Montes, et omnes colles : ligna
 fructifera, et omnes cedri :
 Bestiæ, et universa pecora : ser-
 pentes, et volucres pennatæ :
 Reges terræ, et omnes populi : prin-
 cipes, et omnes judices terræ :
 Juvenes et virgines, senes cum
 junioribus, laudent Nomen Domini :
 quia exaltatum est Nomen ejus solius.

Confessio ejus super cælum et ter-
 ram : et exaltavit cornu populi sui. *exaltabit*

Hymnus omnibus sanctis ejus : filiis
 Israël, populo appropinquanti sibi. *adpropianti*

PSALMUS CXLIX.

CANTATE Domino canticum novo-
 vum : laus ejus in ecclesia sanc-
 torum. *Lauds, ferial and
 festival.
 Lauds of the de-
 parted.*

Lætetur Israël in eo qui fecit eum :
 et filii Sion exsultent in Rege suo.

Laudent Nomen ejus in choro : in
 tympano et psalterio psallant ei.

Quia beneplacitum est Domino in
 populo suo : et exaltavit mansuetos in
 salutem.

Exsultabunt sancti in gloria : læta-
 buntur in cubilibus suis.

Exsultationes Dei in gutture eorum : *faucibus eorum*
 et gladii ancipites in manibus eorum.

Ad faciendam vindictam in nationi-
 bus : increpationes in populis.

Ad alligandos reges eorum in com-
 pedibus : et nobiles eorum in manicis *vinculis*
 ferreis.

Ut faciant in eis judicium conscrip-
 tum : gloria hæc est omnibus sanctis
 ejus.

spake of the foundation of the earth by Himself: "when the morning stars sang together, and all the sons of God shouted for joy." [Job xxxviii. 7.] When man fell, God said, "Cursed is the ground for thy sake," and St. Paul declares that the whole Creation groaneth and travaileth together, waiting for the adoption and redemption of man by the work of Christ. When, therefore, the Incarnation had changed the face of things, there was, doubtless, a participation even of the lower world of Creation in the blessings and joy which it brought, according to the prophecy, "The mountains and the hills shall break forth before you into

singing, and all the trees of the field shall clap their hands." [Isa. lv. 12.] "Sing, O ye heavens; for the Lord hath done it: shout, ye lower parts of the earth: break forth into singing, ye mountains, O forest, and every tree therein: for the Lord hath redeemed Jacob, and glorified Himself in Israel." [Isa. xlv. 23.]

PSALM CXLIX.

The last verse of the preceding Psalm forms the theme out of which this one is developed. For the congregation of saints is the Church of Christ, the spiritual children of Israel: the Israel

THE CL PSALM.

Laudate Dominum.

The XXX. Day.
Evening
Prayer.
Isa. vi. 3.
Rev. xxi. 22.
Rev. xv. 3.

O PRAISE God in his holiness :
praise him in the firmament of
his power.

2 Praise him in his noble acts :
praise him according to his excellent
greatness.

Rev. xiv. 2.

3 Praise him in the sound of the
trumpet : praise him upon the lute
and harp.

4 Praise him in the cymbals and
dances : praise him upon the strings
and pipe.

5 Praise him upon the well-tuned
cymbals : praise him upon the loud
cymbals.

Rev. vi. 13.

6 Let every thing that hath breath :
praise the Lord.

PSALMUS CL.

LAUDATE Dominum in sanctis Lauds, ferial and
festival.
ejus : laudate eum in firma- Lauds of the de-
parted.
mento virtutis ejus.

Laudate eum in virtutibus ejus : in potentatibus
ejus
laudate eum secundum multitudinem
magnitudinis ejus.

Laudate eum in sono tubæ : laudate
eum in psalterio et cithara.

Laudate eum in tympano et choro :
laudate eum in chordis et organo.

Laudate eum in cymbalis beneso-
nantibus ; laudate eum in cymbalis
jubilationis : omnis spiritus laudet
Dominum.

whom Christ has made anew ; the children of the New Jerusalem
of which He is the King ; the "servants" that "shall serve Him."

The fifth verse plainly gives the key to the prophetic meaning
of the Psalm as a hymn of joy for those who sleep in the Lord
Jesus in the Day of the general Resurrection : "Thy dead men
shall live, together with my dead body shall they arise. Awake
and sing, ye that dwell in dust : for thy dew is as the dew of
herbs, and the earth shall cast out the dead."

Perhaps it is within the proper bounds of allegorical interpreta-
tion to consider the "two-edged sword" as the Cross of Victory,
the banner of the Church's final triumph over evil. Yet it must
be remembered that our Lord prophesied to His Apostles that
they should "sit on twelve thrones judging the twelve tribes of
Israel," and that St. Paul wrote, "Do ye not know that the
saints shall judge the world ?" Three times also in the Revelation
our Lord is represented as having a sharp two-edged sword, this
being twice said to proceed out of His mouth [Rev. i. 16 ; xix.
15], when He goes forth to judgment as the WORD of God.
Such words as those of this Psalm may therefore reveal that in
the final triumph of the glorified Church it will be a partaker
with Christ in His work of judgment.

PSALM CL.

The last Psalm is one which prefigures the song of praise that
will rise before the Throne of God when there shall be no more
curse, when evil no longer has a place in the City of God, and
tears and sorrow shall be known in it no more. Hence the last

verse of the preceding Psalm is again taken up by the first of that
which follows ; and the "honour of God's saints" is identified
with that glory of which Daniel spoke when he prophesied,
"They that be wise shall shine as the brightness of the firmam-
ent" [Dan. xii. 3], and our Lord when He said, "Then shall
the righteous shine forth as the sun in the Kingdom of their
Father." [Matt. xiii. 43.]

For the Church has arrived at the end of her Militant and her
waiting condition, and is henceforth to praise God in His inner
Sanctuary, the Heavenly Jerusalem in which there is "no temple,"
"for the Lord God Almighty and the Lamb are the temple of it."
There will the saints remember the "noble acts" of the Lord,
singing to the "harps of God" the "song of Moses the servant
of God, and the song of the Lamb, saying, Great and marvellous
are Thy works, Lord God Almighty ; just and true are Thy ways,
Thou King of Saints."

Thus the songs of David and of the Temple have become the
songs of Christ and of the Church Militant. Thus will the same
strains sound in the hymns of the Church Triumphant. And thus
shall the last words of the last Psalm receive that further, most
glorious, fulfilment which was foreshadowed to St. John when the
door was opened in Heaven : "And every creature which is in
Heaven, and on the earth, and under the earth, and such as are
in the sea, and all that are in them, heard I saying, Blessing,
and honour, and glory, and power, be unto Him that sitteth upon
the throne, and unto the Lamb for ever and ever."

ALLELUIA, FOR THE LORD GOD OMNIPOTENT REIGNETH.

FORMS OF PRAYER

TO BE

USED AT SEA.

¶ *The Morning and Evening Service to be used daily at Sea shall be the same which is appointed in the Book of Common Prayer.*

¶ *These two following Prayers are to be also used in her Majesty's Navy every day.*

Deut. iv. 39.
Job ix. 8. xxvi.
10. xxxviii.
8. 11.
Jer. xvii. 5. 7.
1 Tim. ii. 8.
Ps. cviii. 11, 12.
lxv. 7. cvii.
23, 24. 28.
1 Kings v. 4.
1 Tim. ii. 1, 2.
Ps. xxix. 11.
cxxxviii. 2.
cvii. 8. lxxxvi.
12.
Eph. v. 20.

"Kingdoms" in
the Sealed
Books.

O ETERNAL Lord God, who alone spreadest out the heavens, and rulest the raging of the sea; who hast compassed the waters with bounds until day and night come to an end; Be pleased to receive into thy Almighty and most gracious protection the persons of us thy servants, and the Fleet in which we serve. Preserve us from the dangers of the sea, and from the violence of the enemy; that we may be a safeguard unto our most gracious Sovereign Lady, Queen *VICTORIA*, and her Dominions, and a security for

such as pass on the seas upon their lawful occasions; that the inhabitants of our Island may in peace and quietness serve thee our God; and that we may return in safety to enjoy the blessings of the land, with the fruits of our labours, and with a thankful remembrance of thy mercies to praise and glorify thy holy Name; through Jesus Christ our Lord. *Amen.*

The Collect.

PREVENT us, O Lord, in all our doings, with thy most gracious favour, and further us with thy continual help; that in all our works begun, continued, and ended in thee, we may glorify thy holy Name, and finally by thy mercy obtain everlasting life; through Jesus Christ our Lord. *Amen.*

Jer. x. 23.
Isa. liii. 12.
Ps. xc. 17.
Col. iii. 17.
Rom. vi. 22.

¶ *Prayers to be used in Storms at Sea.*

Jer. xxxii. 18.
Ps. xxix. 1-4.
10.
Nahum i. 3, 4.
Ps. cvii. 25.
lxxxix. 9.
Isa. lxiv. 8, 9.
Ps. cxli. 1.
Matt. viii. 25.
xiv. 30.
Ps. xxx. 6.
Neh. ix. 17, 26.
1 Thess. v. 3.
Ps. lxvi. 3, 5.
xcvi. 4.
1 Chron. xxix. 11.
Ps. xxxi. 19.
John xvi. 23.

O MOST powerful and glorious Lord God, at whose command the winds blow, and lift up the waves of the sea, and who stillest the rage thereof; We thy creatures, but miserable sinners, do in this, our great distress cry unto thee for help: Save, Lord, or else we perish. We confess, when we have been safe, and seen all things quiet about us, we have forgot thee our God, and refused to hearken to the still voice of thy word, and to

obey thy commandments: But now we see, how terrible thou art in all thy works of wonder; the great God to be feared above all: And therefore we adore thy Divine Majesty, acknowledging thy power, and imploring thy goodness. Help, Lord, and save us for thy mercy's sake in Jesus Christ thy Son, our Lord. *Amen.*

Or this.

O MOST glorious and gracious Lord God, who dwellest in heaven, but beholdest all things below;

Exod. xv. 6. 11.
Ps. cxlii. 1.
Isa. lxiii. 15.
Ps. cxxx. 1, 2.
Jonah ii. 2, 3.
i. 4-6.

PRAYERS TO BE USED AT SEA.

THESE forms of Prayer were composed, and inserted here at the Revision of 1661. They were probably written or compiled by Bishop Sanderson¹, but they have not been traced in any older

¹ The examination and revision of them was committed by Convocation to Stern, Bishop of Carlisle, on September 27th, 1661.

form, and those portions which are not taken from other divisions of the Prayer Book are probably original compositions drawn up for the occasion. They are mentioned in the Preface as one of the additions which it was thought expedient to make, but no further light is thrown upon their origin. The only parallel to them in the ancient services is a *Missa pro Navigantibus*, but this is not represented in any of the present forms.

It is not unlikely that they were suggested by a "Supply of

Ps. lxi. 1—3. 13
—15.
Isa. xxxviii. 19,
20.
Matt. viii. 25, 26.
Ps. lxxv. 5. 7.
cvii. 26—32.
Ps. lxxxvi. 12.
Ps. xxx. 10.
1 Chron. xvi. 35.
John xvi. 23, 24.

Look down, we beseech thee, and hear us, calling out of the depth of misery, and out of the jaws of this death, which is ready now to swallow us up: Save, Lord, or else we perish. The living, the living, shall praise thee. O send thy word of command to rebuke the raging winds, and the roaring sea; that we, being delivered from this distress, may live to serve thee, and to glorify thy Name all the days of our life. Hear, Lord, and save us, for the infinite merits of our blessed Saviour, thy Son, our Lord Jesus Christ. *Amen.*

¶ *The Prayer to be said before a Fight at Sea against any Enemy.*

1 Chron. xxix. 11.
Dan. iv. 17. 35.
Ps. ix. 4.
2 Sam. xxii. 7.
2 Chron. xx. 10—
13.
Rom. xii. 19.
Ps. lxxx. 2.
Ecc. ix. 11.
1-Sam. xiv. 6.
Gen. iy. 10.
Neh. i. 11.
Ps. xxxi. 2.
lix. 1.
lxxxiii. 17, 18.
Isa. xli. 14, 20,
xlix. 26.

O MOST powerful and glorious Lord God, the Lord of hosts, that rulest and commandest all things; Thou sittest in the throne judging right, and therefore we make our address to thy Divine Majesty in this our necessity, that thou wouldest take the cause into thine own hand, and judge between us and our enemies. Stir up thy strength, O Lord, and come and help us; for thou givest not always the battle to the strong, but canst save by many or by few. O let not our sins now cry against us for vengeance; but hear us thy poor servants begging mercy, and imploring thy help, and that thou wouldest be a defence unto us against the face of the enemy. Make it appear that thou art our Saviour and mighty Deliverer, through Jesus Christ our Lord. *Amen.*

¶ *Short Prayers for single persons, that cannot meet to join in Prayer with others, by reason of the Fight, or Storm.*

General Prayers.

Ps. vi. 4.
Luke xviii. 13.

LORD, be merciful to us sinners, and save us for thy mercy's sake.

Neh. ix. 6. 32.
Ps. lxxix. 9.

Thou art the great God, that hast made and rulest all things: O deliver us for thy Name's sake.

Ps. xev. 3.
cxix. 173.

Thou art the great God to be feared above all: O save us, that we may praise thee.

Special Prayers with respect to the Enemy.

Deut. xxxii. 4.
Ps. xxxv. 1.
Ps. xliii. 1.

THOU, O Lord, art just and powerful: O defend our cause against the face of the enemy.

Ps. cxliiv. 1, 2.
Ps. lxxii. 6, 7.
cxl. 1.

O God, thou art a strong tower of defence to all that flee unto thee: O save us from the violence of the enemy.

Josh. xxxiii. 10.
Ps. i. 15.

O Lord of hosts, fight for us, that we may glorify thee.

Ps. lxxix. 14, 15.
lxxii. 14.

O suffer us not to sink under the weight of our sins, or the violence of the enemy.

Ps. vii. 6.
Ps. cix. 21.

O Lord, arise, help us, and deliver us for thy Name's sake.

Short Prayers in respect of a Storm.

Ps. lxxv. 5, 7.
Dan. ix. 19.
Jonah i. 14.

THOU, O Lord, that stillest the raging of the sea, hear, hear us, and save us, that we perish not.

Luke viii. 22—24.
Ps. cxviii. 29.

O blessed Saviour, that didst save thy disciples ready to perish in a storm, hear us, and save us, we beseech thee.

Lord, have mercy upon us.

Christ, have mercy upon us.

Lord, have mercy upon us.

O Lord, hear us

O Christ, hear us.

God the Father, God the Son, God the Holy Ghost, have mercy upon us, save us now and evermore. *Amen.*

OUR Father, which art in heaven Hallowed be thy Name. Thy kingdom come. Thy will be done in earth, As it is in heaven. Give us this day our daily bread. And forgive us our trespasses, As we forgive them that trespass against us. And lead us not into temptation; But deliver us from evil: For thine is the kingdom, The power, and the glory, For ever and ever. *Amen.*

¶ *When there shall be imminent danger, as many as can be spared from necessary ser-*

Prayer for the Ships that want Ministers to pray with them," which was set forth by the rebel Parliament as a supplement to the "Directory of Public Worship," intended by them to supersede the Prayer Book. In the preface to this it is stated that the Common Prayer is still used on board ship, though "for many weighty reasons abolished:" and to prevent the necessity of using it any longer "it hath been thought fit to frame some prayers agreeing with the Directory established by Parliament."

On the restoration of the Prayer Book it was probably felt that

the great increase of the Navy through the regular levy of "ship money" during Cromwell's time had made some special prayers of this kind desirable.

The prayers are for "occasional" use, with the exception of the first two: and all that calls for notice is the fact that they are framed on the strict principles of the Church of England. Confession and Absolution are appointed, in extreme danger, as a reality to which men will be glad to fly when their souls are about to appear suddenly before God. The responsive form is

vice in the Ship shall be called together, and make an humble Confession of their sin to God: In which every one ought seriously to reflect upon those particular sins of which his conscience shall accuse him; saying as followeth,

The Confession.

2 Cor. i. 3.
Dan. ix. 4.
Heb. xii. 23.
Ps. xxxii. 5.
Neh. ix. 33, 34.
Jer. iv. 14.
James iii. 2.
Ps. li. 4.
Dan. ix. 14.
Ps. xxxviii. 18.
2 Cor. vii. 10.
Ps. xxxi. 9, 10.
Job vii. 20, 21.
Ps. cxliii. 3.
Ivii. 1.
John xvi. 23.
1 John i. 8, 9.
1 Cor. vi. 20.
Gal. ii. 20.
1 Chron. xxix. 11.

ALMIGHTY God, Father of our Lord Jesus Christ, Maker of all things, Judge of all men; We acknowledge and bewail our manifold sins and wickedness, Which we, from time to time, most grievously have committed, By thought, word, and deed, Against thy Divine Majesty, Provoking most justly thy wrath and indignation against us. We do earnestly repent, And are heartily sorry for these our misdoings; The remembrance of them is grievous unto us; The burden of them is intolerable. Have

mercy upon us, Have mercy upon us, most merciful Father; For thy Son our Lord Jesus Christ's sake, Forgive us all that is past; And grant that we may ever hereafter Serve and please thee In newness of life, To the honour and glory of thy Name; Through Jesus Christ our Lord. Amen.

¶ *Then shall the Priest, if there be any in the Ship, pronounce this Absolution.*

ALMIGHTY God, our heavenly Father, who of his great mercy hath promised forgiveness of sins to all them that with hearty repentance and true faith turn unto him; Have mercy upon you; pardon and deliver you from all your sins; confirm and strengthen you in all goodness, and bring you to everlasting life; through Jesus Christ our Lord. Amen.

Dan. ix. 9.
Joel ii. 12-14.
Ezek. xviii. 30-32.
Jer. xxxiii. 8.
Rom. vi. 14.
Dan. xi. 1.
Col. i. 14, 11.
Rom. vi. 22.

Thanksgiving after a Storm.

Jubilate Deo. Psalm lxvi.

Confitemini Domino. Psalm cvii.

Collects of Thanksgiving.

[Printed at length in the Sealed Books.]

1 Chron. xxix. 10-12, 20.
Ps. ciii. 17.
Wisd. xvi. 13.
Ps. lxvi. 9.
Dan. vi. 27.
Ps. lxvi. 13, 14.
Ps. cvii. 21, 22.
Ps. cvii. 6.
Ps. lxvii. 18.
2 Cor. i. 9, 10.
Ps. cvii. 28-30, xxxii. 7, 11.
Wisd. xiv. 3, 4.
Rom. xi. 36.

O MOST blessed and glorious Lord God, who art of infinite goodness and mercy; We thy poor creatures, whom thou hast made and preserved, holding our souls in life, and now rescuing us out of the jaws of death, humbly present ourselves again before thy Divine Majesty, to offer a sacrifice of praise and thanksgiving, for that thou heardest us when we called in our trouble, and didst not cast out our prayer, which we made before thee in our great distress: even when we gave all for lost, our ship, our goods, our lives, then didst thou mercifully look upon us, and wonderfully command a deliverance; for which we, now being in safety, do give all praise and glory to thy holy Name; through Jesus Christ our Lord. Amen.

Or this:

O MOST mighty and gracious good God, thy mercy is over all thy works, but in special manner hath been extended toward us, whom thou hast so powerfully and wonderfully defended. Thou hast shewed us terrible things, and wonders in the deep, that we might see how powerful and gracious a God thou art; how able and ready to help them that trust in thee. Thou hast shewed us how both winds and seas obey thy command; that we may learn, even from them, hereafter to obey thy voice, and to do thy will. We therefore bless and glorify thy Name, for this thy mercy in saving us, when we were ready to perish. And, we beseech thee, make us as truly sensible now of thy mercy, as we were then of the danger: And give us hearts always ready to express our thankfulness, not only by words, but also by our lives, in being more obe-

Ps. lxxxix. 8, 9, 13.
Wisd. xiv. 3, 4.
2 Sam. xxii. 11, 14, 16, 17.
Ps. lxxv. 5.
Ps. cvii. 23, 24.
Ps. lxiv. 9.
Matt. xiv. 30, 31.
Ps. xxxi. 19.
Matt. viii. 27.
Mark iv. 39, 41.
Ps. cvii. 25, 29.
Matt. vii. 10.
Isa. xxxviii. 20.
Ps. cvii. 4, 5, cvii. 18, 19, 21.
Exod. xv. 1, 2.
Jonah ii. 9.
Deut. v. 29.
Ps. cxix. 32.
Rom. xii. 1.
Luke i. 74, 75.
Gal. ii. 20.

kept up throughout: and the "Hymns of Praise and Thanksgiving," as well as the use of the "Te Deum" after victory, presuppose a choral use of the Church's services. Some of the Prayers are evidently intended to be used in the same manner and place as the "Occasional Prayers and Thanksgivings," the

ordinary daily Service being directed to be used both by the Rubric at the head of these Forms, and by the first of the "Articles of War." The latter is as follows:—

"Officers are to cause Public Worship, according to the Liturgy of the Church of England, to be solemnly performed in

dient to thy holy commandments. Continue, we beseech thee, this thy goodness to us; that we, whom thou hast saved, may serve thee in holiness and righteousness all the days of our life; through Jesus Christ our Lord and Saviour. *Amen.*

A Hymn of Praise and Thanksgiving after a dangerous Tempest.

Ps. xcvi. 1.
Ps. cvii. 1.
O COME, let us give thanks unto the Lord, for he is gracious : and his mercy endureth for ever.

Ps. xlviii. 1.
Ps. cvii. 2.
Great is the Lord, and greatly to be praised; let the redeemed of the Lord say so : whom he hath delivered from the merciless rage of the sea.

Ps. cxlv. 8.
The Lord is gracious and full of compassion : slow to anger, and of great mercy.

Ps. cxlii. 10.
He hath not dealt with us according to our sins : neither rewarded us according to our iniquities.

Ps. cxlii. 11.
But as the heaven is high above the earth : so great hath been his mercy towards us.

Ps. cxvi. 3.
Ps. cvii. 18.
We found trouble and heaviness : we were even at death's door.

Ps. cxxiv. 4. 3.
The waters of the sea had well nigh covered us : the proud waters had well nigh gone over our soul.

Ps. cxviii. 7.
Ps. cvii. 25.
The sea roared : and the stormy wind lifted up the waves thereof.

Ps. cvii. 26. 28.
We were carried up as it were to heaven, and then down again into the deep : our soul melted within us, because of trouble ;

Then cried we unto thee, O Lord :

After Victory or Deliverance from an Enemy.

A Psalm or Hymn of Praise and Thanksgiving after Victory.

Ps. cxxiv. 1. 2.
IF the Lord had not been on our side, now may we say : if the Lord himself had not been on our side, when men rose up against us ;

Ps. cxxiv. 3.
They had swallowed us up quick :

and thou didst deliver us out of our distress.

Blessed be thy Name, who didst not *Ps. lxxvi. 19, 20.*
cxlv. 19.
despise the prayer of thy servants : but didst hear our cry, and hast saved us.

Thou didst send forth thy commandment : and the windy storm ceased, and was turned into a calm. *Ps. cvii. 29.*
cxlvii. 15.

O let us therefore praise the Lord *Ps. cvii. 18.*
for his goodness : and declare the wonders that he hath done, and still doeth for the children of men.

Praised be the Lord daily : even the Lord that helpeth us, and poureth his benefits upon us. *Ps. lxxviii. 19, 20.*

He is our God, even the God of whom cometh salvation : God is the Lord by whom we have escaped death.

Thou, Lord, hast made us glad *Ps. xcii. 4.*
through the operation of thy hands : and we will triumph in thy praise.

Blessed be the Lord God : even the Lord God, who only doeth wondrous things ;

And blessed be the Name of his Majesty for ever : and let every one of us say, Amen, Amen. *Ps. cvi. 48.*

Glory be to the Father, and to the Son : and to the Holy Ghost ;

As it was in the beginning, is now, and ever shall be : world without end. Amen.

2 Cor. xiii.

THE grace of our Lord Jesus Christ, and the love of God, and the fellowship of the Holy Ghost, be with us all evermore. *Amen.*

when they were so wrathfully displeased at us.

Yea, the waters had drowned us, *Ps. cxxiv. 4, 5.*
and the stream had gone over our soul : the deep waters of the proud had gone over our soul.

But praised be the Lord : who hath not given us over as a prey unto them.

their ships, and take care that prayers and preaching by the chaplains be performed diligently, and that the Lord's Day be observed."

It is worthy of notice that the form with which the body is committed to the deep in the Burial Service differs from the older form in an important particular, "looking for the resurrection of the body . . . and the life of the world to come," being

substituted for "in sure and certain hope of the resurrection to eternal life." This change has been adopted in the American Book of Common Prayer. The difference is only a verbal one, but circumstances have given it importance: and the words above have often been quoted as if they had originated in America instead of in our own revision of 1661; and with (as is probable) so Catholic-minded a Churchman as Bishop Sanderson.

1 Sam. xix. 3. The Lord hath wrought : a mighty salvation for us.

Ps. xlv. 3. We gat not* this by our own sword, neither was it our own arm that saved us : but thy right hand, and thine arm, and the light of thy countenance, because thou hadst a favour unto us.

Ps. cxl. 7. Isa. lxvi. 5. The Lord hath appeared for us : the Lord hath covered our heads, and made us to stand in the day of battle.

Exod. xv. 6, 7. 2 Sam. xxii. 40. The Lord hath appeared for us : the Lord hath overthrown our enemies, and dashed in pieces those that rose up against us.

Ps. cxv. 1. Therefore not unto us, O Lord, not unto us : but unto thy Name be given the glory.

Ps. cxxvi. 3, 4. The Lord hath done great things for us : the Lord hath done great things for us, for which we rejoice.

*Ps. cxxiv. 7. Our help standeth in the Name of the Lord : who hath made heaven and earth.

Ps. cxlii. 2. Blessed be the Name of the Lord : from this time forth for evermore.

Glory be to the Father, and to the Son : and to the Holy Ghost;

*Ps. xli. 13. As it was in the beginning, is now, and ever shall be : world without end. Amen.

¶ After this Hymn may be sung the Te Deum.

¶ Then this Collect.

O ALMIGHTY God, the Sovereign Commander of all the world, in whose hand is power and might which none is able to withstand; We bless and magnify thy great and glorious Name for this happy victory, the whole glory whereof we do ascribe to thee, who art the only giver of victory. And, we beseech thee, give us grace to improve this great mercy to thy glory, the advancement of thy Gospel, the honour of our Sovereign, and, as much as in us lieth, to the good of all mankind. And, we beseech thee, give us such a sense of this great mercy, as may engage us to a true thankfulness, such as may appear in our lives by an humble, holy, and obedient walking before thee all our days, through Jesus Christ our Lord; to whom with thee and the Holy Spirit, as for all thy mercies, so in particular for this victory and deliverance, be all glory and honour, world without end. *Amen.*

2 Cor. xiii.

THE grace of our Lord Jesus Christ, and the love of God, and the fellowship of the Holy Ghost, be with us all evermore. *Amen.*

Rev. xv. 3.
Ps. xlvii. 2, 6, 9.
2 Chron. xx. 6.
Neh. ix. 5.
Ps. xcvi. 1.
xlv. 7, 8.
cxv. 1.
Job xxxvi. 22, 24.
Isa. xlviii. 17.
Ps. lxxvii. 2, 3.
Gal. vi. 10.
Ps. cxvi. 7.
ix. 1.
Luke i. 74, 75.
Rom. xii. 1.
Ps. cxxxvi. 3, 4.
17, 18, 23-26.
1 Tim. i. 17.
*Ps. xli. 13.

At the Burial of their Dead at Sea.

¶ The Office in the Common Prayer-book may be used; Only instead of these words [We therefore commit his body to the ground, earth to earth, &c.] say,

WE therefore commit his body to the deep, to be turned into corruption, looking for the resurrection of the body, (when the sea shall give

up her dead,) and the life of the world to come, through our Lord Jesus Christ; who at his coming shall change our vile body, that it may be like his glorious body, according to the mighty working whereby he is able to subdue all things to himself.

Jonah ii. 6.
1 Cor. xv. 42.
Rev. xx. 13.
John xi. 23-25.
Jude 21.
1 Cor. xv. 52.
Phil. iii. 20, 21.

AN

INTRODUCTION TO THE ORDINAL.

THE fundamental principle of the Christian Ministry is that it is derived from our Blessed Lord Himself, from Whom it is perpetuated by Episcopal Ordination. In virtue of His Incarnation, our Lord, both God and man, received all power both in Heaven and earth, as primarily and plenarily the great High Priest and Apostle of our profession [Heb. iii. 1], the chief Shepherd and Bishop [1 Pet. ii. 25], and Deacon [Rom. xv. 8], anointed with power and the Holy Ghost [Luke iii. 22. Acts x. 37, 38]. Being thus endowed, He gave a commission by immediate substitution to men as fellow-workers with Him to continue the work of His office in His place and Name [John xx. 21] after His departure, in the Church which He had bought with His own blood; and to enable them to do so, He promised that His presence should be with them and their successors until His coming again [Matt. xxviii. 18. 20]. He Himself had the eternal incommunicable [*ἀπαράβατον*, Heb. vii. 24] Priesthood of Melchisedec, and those who ministered under His authority were in so far His successors in it, as being taken from among men not in a family, by birth-right, or according to the law of a carnal ordinance, as in the Aaronic priesthood. This new Priesthood had been foretold by Isaiah [lxvi. 21], by Jeremiah [xxxiii. 18], and Malachi [i. 11], and was to be elected from those whom the Holy Ghost had prepared for the work, by His call and gracious invitation, and merit and devotion recommended, so that in the people of God's adoption, kings and priests, a royal priesthood, it should not be by an earthly privilege, but by the gift of divine grace that the priesthood should be constituted. The Ordinal of the Syro-Nestorians beautifully says, "The Highest dwelt on Mount Zion, and His hand came upon Moses, and Moses laid it on Aaron, and thence it passed even unto John; John gave it to our Lord, our Lord gave it to Apostles, and they to all the orders of the Priesthood."

§ Succession of the Ministry from our Lord.

In order to show the analogy between the Aaronic and Evangelical Priesthoods, our Saviour instituted two Orders only, the Apostles [Mark iii. 14. John iv. 1, 2], who answered to the twelve Patriarchs and twelve Princes of the tribes, and the seventy disciples [Luke x. 1], who corresponded to the seventy fathers of families and elders of the Jews, whom Moses elected to govern the people of Israel [Burscough, Ch. Gov. ch. ii. p. 80. Bp. Andrewes, Minor Works, p. 351. Dr. Hammond, Dissert. against Blondel, c. ix. § v.]; or, as Anacletus says, the Orders of Bishops and Priests [Ep. iii. 8. 1].

An essential difference was placed between these Orders, for the Apostles were chosen to company with Christ in His temptations [Luke vi. 13; xxii. 28], received a distinct charge [Matt. xxviii. 19], and after His Ascension were baptized with fire and the Holy Ghost [Matt. iii. 11]. St. Chrysostom says that St. James was consecrated by our Lord Himself. The title of the Twelve was continued after the fall of Judas and the reception of other Apostles into the Sacred College [John xx. 24. 1 Cor. v. 5. Rev. xxi. 14]. St. Matthias was the successor of Judas, St. Paul of St. James the Less, and St. Barnabas of St. James the Great. The Apostles were representatives of the Head over

all to the Church, of which they were constituted Governors [Heb. xiii. 17] with spiritual authority [1 Cor. ix. 6. 12. 19. 1 Thess. iii. 9. John xviii. 36. 2 Cor. x. 6; xiii. 2. 10. 1 Cor. iv. 21] in His Kingdom [1 Cor. xv. 25. Matt. xix. 28. John vii. 39; xi. 16. 1 Pet. i. 21] under Him [Matt. xxiii. 10. 2 Cor. i. 14. 2 Thess. iii. 6; v. 4. 12. 1 Thess. iv. 11]. This power and authority remained in their office after their decease, with external and visible exercise, being transmitted to the chief pastors of the Church; for the Apostolate was in substance an Episcopate [Acts i. 20. 24, 25], an office of Divine institution, never abrogated by any precept of God, and not appropriated to the Apostles; being continued in order that there might be a ministration of those Sacraments which depended on a succession to the Apostolate for their lawful administration, agreeably to the promise of the Redeemer attached to their commission, which was designed in perpetuity for the supervision of His Church. This commission was to bring all nations under the discipline, and into the doctrine of the Lord Jesus, and is a right which descends to their spiritual heirs. The promise was to the office, not to the persons of the Apostles; and the office consisted in the propagation, edification, and government of the Church in all ages, and so they understood it, and therefore ordained others to take part in it and continue it. The promise of miraculous powers was restricted to their persons, and was temporary; but the assurance of the perpetual presence of Christ Himself in spirit and in power with the Bishops of His Church, who derive from the Apostles in uninterrupted succession, and with priests and deacons (who are constituted by the same authority and devoted to His service), is limited only by the end of all things.

Their extraordinary powers, and the Apostolate itself, ceased with the death of the Apostles, being, like their qualifications, special seals of their commission, and, being personal, were incommunicable. But they, acting of necessity [*δεῖ ἡμᾶς*, Acts i. 22], as in obedience to Divine direction, chose St. Matthias out of the number of the Seventy Disciples to be one of their own order, and further ordained a Bishop over each newly-erected Church. In order to continue the stewardship and ministration of the Divine Mysteries and the Word of life, it was indispensable to have men holy by their office, whose exclusive privilege should be attested not by individual presumption, or natural capacity, inclination, and preparation for its discharge, but by sufficient credentials. These could only be afforded by an open external call and mission, according to the appointment of God, Who is the Author of personal ability [2 Cor. iii. 6], and of authority and power of delegation [Matt. viii. 9. Luke vii. 8. John xiii. 20; xx. 21], by those rulers of His Church to whom, by an inalienable right, such power upon earth has been permitted to continue and to convey a spiritual succession. So we may observe that under the Law the Priests were required to prove their title to the sacred office by reference to their descent from the tribe of Levi, as proved by the registers of genealogy [Neh. vii. 64].

These chief pastors, or bishops, inherited the powers of Ordination, Government, and Church censures, the ordinary parts of the Apostolical office, the offering of spiritual sacrifice, the administration of the Holy Sacraments [Matt. xxviii. 19. Luke xxii.

19], the preaching of the Word [Mark xvi. 15], the Power of the Keys [Matt. xviii. 18. John xx. 23]; they were to be as pillars of the Church [Gal. ii. 19], as lights in the world [Matt. v. 14]; to be heard and received in Christ's stead [Matt. x. 40. Luke x. 16]. As the Priests under the Law exercised the ordinary sacerdotal offices although not called, like Aaron and his sons, in an extraordinary way, so these did not inherit the miraculous effusion, or the infallible guidance of the Holy Ghost [1 Tim. i. 18, 19; v. 21, 22], or an unlimited mission, as St. Paul did [1 Cor. xi. 23. Comp. John xiv. 26; xvi. 13]. They are called mediately through the Church by Ordination, they receive grace for grace, and are first tried, proved, and examined; but the heavenly mysteries having been first confided to their order, they, as the agents of the Holy Spirit, acting by commission from Christ, send forth priests and deacons. He that receiveth them receiveth Christ, and he that receiveth Christ receiveth Him that sent Him [Matt. x. 40. John xiii. 20. Mark ix. 37. Luke ix. 48]. Such is the doctrine of the Church of England: "The office and function of Priests and Ministers of the Church is appointed of God" [Royal Injunc. 1559, § xxviii.; 1547, § xxxii.]. "Holy Scripture openly teacheth that the order and ministry of Priests and Bishops was instituted of God, not by man's authority" [Cranmer's Paper, 1538, art. xv.]. "All are agreed that the Apostles received power of God to create Bishops" [Resol. of Bishops and Divines, 1540]. The twenty-sixth Article declares that the Clergy act "not in their own name, but in Christ's, and do minister by His commission and authority;" and the words of the Prayer Book are, "Almighty God, who by Thy Divine Providence" [Collect for Ember week], "by Thy Holy Spirit" [Collect in the Ordinal], "hast appointed divers orders of Ministers in Thy Church." The institution of the Ministry is from heaven, is of God, and the Holy Ghost is the Author of it.

§ *Succession of the Ministry from the Apostles.*

The order of Bishops is essential to the outward being of a Church. "Scire debet Episcopum in Ecclesiâ esse et Ecclesiam in Episcopo; et si qui cum Episcopo non sint in Ecclesiâ non esse" [St. Cyr., Epist. lxxvi. § 7]. "Ὅπου ἂν φάσῃ ὁ ἐπίσκοπος ἐκεῖ τὸ πλῆθος ἔστω, ὡσπερ ὄπου ἂν ᾖ Χριστὸς Ἰησοῦς ἐκεῖ ἡ καθολικὴ ἐκκλησία" [St. Ignat., Ep. ad Smyrn. § viii.]. But even before the ordination of Bishops, the Apostles then being alive, deacons were chosen as coadjutors, at first in relieving them of secular business, but subsequently with permission to preach and baptize [Acts viii. 5, 38]; and this, which was the constitution of the Church of Jerusalem, was adopted in cities [Tit. i. 5] which were too small to require the ministrations of Priests, as at Philippi [Phil. i. 1. St. Clem. ad Corinth. c. xlii.]. Thus Titus and Timothy by St. Paul, Clement by St. Peter, Polycarp of Smyrna by St. John, and St. Mark of Alexandria, and Evodius of Antioch, were consecrated bishops. However, as the "care of all the Churches" [2 Cor. xi. 28. Acts xv. 36. 1 Cor. v. 4] devolved on the Apostles, and their representatives the bishops in separate and local Churches found the oversight too laborious without assistance in their sacerdotal functions, they appointed Priests, about the year 45, though reserving to the chief pastors the rights of laying on of hands, jurisdiction, government, and episcopal visitation. These bodies of Priests are invariably mentioned in the plural number, as by St. Peter [1 Pet. v. 1] and St. Paul [1 Thess. v. 12. Tit. i. 5. Heb. xiii. 7. 1 Tim. v. 17]; and in consequence of their local supervision of places where there was no resident Bishop they were sometimes called Bishops [Acts xx. 28. 1 Pet. v. 2. Phil. i. 1]; they corresponded to the Seventy, being in that afterwards called technically the second order of Priesthood, Bishops occupying the first order, and then, as Theodoret says, called Apostles [in 1 Tim. iii.]. But until the second century the names were not invariably distinguished [St. Aug., Ep. lxxxii. Theodoret in 1 Tim. c. iii. St. Chrys., Hom. 1, ad Phil. c. 1]; thus St. John and St. Peter call themselves Priests [1 Pet. v. 1. 2 John 1]. St. Paul mentions Epaphroditus, without himself, as an Apostle [Phil. ii. 25], and Timothy as a Deacon [2 Tim. iv. 5]. By some mediæval and later ritualists the doctrine was held that Bishops and Priests formed one order

with two degrees, and St. Jerome says that with the ancients the same man was bishop and priest, for one is a name of dignity, the other of age [Ep. lxxxii. ad Ocean. Comp. Theod. iii. p. 1, p. 700; and Theophylact, tom. ii. p. 626, A]. But the Apostles, foreseeing that there would be a strife among the Priests who should be the greatest [St. Clem. Rom. c. xlv.], which would endanger unity, appointed chief overseers of the Churches [St. Hieron., Epist. c. 1, ad Evang., and Comm. in Ep. ad Tit. c. 1. St. Cyr., Ep. lv.] in provinces and principal cities. These were at first called also Angels [Phil. ii. 25. Rev. i. ii.], and had their known authority and superior place established a long time before their settled distinction of name and title took place. It is not improbable that the Apostolical Bishops may have been called Angels as ministering the New Testament with reference to the fact of the Law having been received by the disposition of angels [Acts vii. 53. Gal. iii. 19. Heb. ii. 12], and of our Lord being called the Angel of the presence [Isa. lxiii. 9] and of the covenant [Mal. iii. 1. Ps. lxxviii. 8. Numb. xx. 16. Exod. xxxii. 34; xxxiii. 2]; and St. Paul says that the Galatians received him as an angel of God [Gal. iv. 14]. At length the interchange of names ceased, and the three orders of Bishops, Priests, and Deacons were determined and distinguished nominally, even as from the beginning of Church polity they had been essentially distinct in office and powers.

It would be impossible within the compass of the space at our disposal to give a complete series of patristic authorities to illustrate the great fact of the Apostolical succession. A few must suffice.

St. Ignatius [A.D. 107]: "The Bishop sitting in God's place, Priests in the place of the company of Apostles, and Deacons" [ad Magnes. c. vi.].—St. Irenæus [A.D. 202]: "We can reckon up to our time" [Hær. l. i. c. iii. § 1, 2].—St. Clement of Alexandria [A.D. 218]: "The Ecclesiastical honours of Bishops, Priests, and Deacons are, I trow, the resemblance of angelic glory" [Strom. l. vi. c. xiii.; Pæd. l. iii. c. xii.].—Tertullian [A.D. 220]: "The High Priest, i. e. the Bishop, has the right of giving baptism, then Priests and Deacons, but not without his authority" [de Bapt. c. xvii.]¹.

Our adorable Lord was Himself externally commissioned for His Ministry by the visible descent of the Holy Ghost upon Him, and by an audible voice from heaven proclaiming Him to be the Messiah when He was about thirty years old. "Christ glorified not Himself to be made an high priest, but He that said unto Him, Thou art My Son, this day have I begotten Thee" [Heb. v. 5]. None of His Apostles or disciples presumed to undertake any ministry until they received a direct commission from Him [Mark iii. 14. John iv. 2. Luke x. 1]. It was the direct prophecy of God Himself that He would take for Priests and Levites [Isa. lxxv. 21], and therefore, as St. Paul says of the Evangelical Ministry, "No man taketh this honour to himself but he that is called of God, as was Aaron" [Heb. v. 4]. Aaron, his sons, and all the Levites (corresponding to Bishops, Priests, and Deacons), were commissioned by God [Lev. viii. 1, 2. Numb. iii. 5], and death was the penalty of an invasion of their office [Numb. iii. 10; xviii. 17], as in the instance of Korah, Dathan, and Abiram [Numb. xvi. 39, 40]; and Uzzah, for acting in things pertaining to God without a divine commission [2 Sam. vi. 6, 7]. Saul lost his kingdom for offering sacrifice [1 Sam. xiii. 12, 14], and Uzziah was smitten with leprosy and excommunicated for burning incense [2 Chron. xxvi. 16], whilst Jeroboam's especial sin was that he consecrated all comers to the priesthood [1 Kings xiii. 33, 34; xii. 31]; and the heaviest censures of God are

¹ See also de Præsc. Hær. c. xxxii. xli.; Scorpiace, c. ix. Similar testimonies may be found in Origen, A.D. 254 [Hom. in Matt. c. xxii. Tr. xxiii.; in Hierem. Hom. xi.]; St. Cyprian, A.D. 258 [Ep. lxxix. § 4; lxxvi. § 3; xxxi. § 4]; Eusebius [Eccles. Hist. l. iii. c. iv.; iv. c. xxii.]; Optatus, A.D. 386 [de Schism. Donat. lib. i. c. xlii. xiv.]; St. Ambrose, A.D. 397 [de Dign. Sacerd. c. iii. in Ps. cxviii.]; Epiphanius, A.D. 403 [Hær. l. iii. c. lxxix.]; St. Chrysostom, A.D. 407 [in 1 ad Tim. c. iii. Hom. xl.]; St. Jerome, A.D. 420 [ad Heliod., Ep. v. adv. Lucif., ad Marcell. xxvii., in Ps. xlii.]; St. Augustine [de Bapt. l. vii. c. xliii., de Verb. Evang. Sermon. cii., de Mor. Eccles. lib. i. c. xxxii.].

denounced on all usurpers of the prophetic office [Jer. xxiii. 19. 21. 31]. Such intruders, who come in their own name, are characterized by our Lord Himself as thieves and robbers [John v. 43; x. 1. 8]. St. Paul expressly speaks of the distinct ministerial offices as of God's ordinance [1 Cor. xii. 28, 29. Rom. xii. 7. Eph. iv. 11, 12]. "How shall they preach," he asks, "except they be sent?" [Rom. x. 15.] So also our Blessed Lord said, "As Thou hast sent Me into the world, even so have I sent them" (the Apostles) [John xvii. 18]; and, "Ye have not chosen Me, but I have chosen you, and ordained you" [ib. xv. 16].

§ *Derivation of the English Ordinal.*

As there was only one Pontifical for the use of each diocese, copies of such collections of Services are among the rarest of ecclesiastical books. The Pontifical of Salisbury—collated with that of Winchester, which is in the University Library at Cambridge, and of Bangor, preserved among the cathedral muniments—has been printed by Mr. Maskell in his *Monumenta Rititalia*; and that of Exeter by Mr. Barnes. The Pontifical of Egbert has been published by the Surtees Society, and there are other uses in the Bodleian Library, Oxford; and, mostly imperfect, among the MSS. of the British Museum. These sources of information, collated with ancient Sacramentaries, Italian and French Pontificals, the Euchologium of the Greek Church, and the Ordinals of other Churches of that Communion, published by Martene, Morin, and Assemani, form the groundwork of the present illustrations of the English Ordinal: whilst the works of Catalani, Hallier, Morin, and Muratori, and the notes of Menard, and writers contained in the volume printed by Hittorp, have been freely used. It is a remarkable fact that English writers, such as Wheatley, Sparrow, and L'Estrange, have wholly omitted the subject; Mr. Palmer and Mr. Procter have only cursorily illustrated the Services; Bp. Cosin made his notes, now in his Library at Durham and in the British Museum, in copies of the Book of Common Prayer which do not contain the Forms of Ordination; and Dean Comber, like Dr. Mant and Dr. Doyly and Mr. Pinder, has done little more than offer some practical observations. With the exception therefore of a volume on the English Ordinal by the present writer, this series of notes may be regarded as the first ritualistic illustration of this all-important portion of the Book of Common Prayer, whilst they embody the earliest complete account of its development from ancient sources. For our Ordinal was not taken word for word from the Roman Pontifical, as Archbishop Whitgift asserted, but framed on the comprehensive and broad ground of all known forms and manners of Ordination used in all branches of the Catholic Church.

There was a British Church existing in the second century, and founded in the Apostolic age [Eusebius, *Demonst. Evang.* l. iii. c. vii. Theodoret *adv. Gent.* Disp. ix. in Ps. cxvi., *Interpr.* Tertullian *adv. Jüd.* c. vii. St. Clement, *Ep. ad Corinth.* c. v. St. Jerome, *Catal. Script. Eccl.* § v.]. In 314, at the Council of Arles, probably at Nicæa, 325, certainly at Sardica, 347, and Rimini, 360, British Bishops were present. In 428, St. Germain, Bishop of Auxerre, and Lupus, Bishop of Troyes, consecrated several Bishops [Bede, *Hist. Eccl.* l. i. c. xvii.], doubtless with the Gallican form, which had been derived from the Eastern Church. In 597, St. Augustine was consecrated by Æthérius, Bishop of Lyons, and Virgilius, Bishop of Arles; Wilfrid of York by Agilbert, Bishop of Paris, 665. There were also bishops consecrated in Rome, and Italy, by Saxon, Irish, and Scotch Bishops, several of the latter having derived their orders from Rome. For the purpose of simplifying the history of the gradual development of successive Ordinals, the contents of those used in England from the fifth century to the present time have been given, as well as the earliest known forms preserved in Sacramentaries, which prove that the latter were accepted as the formularies of the Western Church. It is certain that the further we can trace back rituals, the simpler they are; for they only gradually received additions and enlargement, with fresh rubrics designed to enhance the solemnity of the ceremonial. Possibly these were the ignorations of an individual bishop, adopted by neighbouring diocesans, until authoritatively recognized. But they were changed according to

the diversities of countries, times, and men's manners. It will be seen how much they varied. While the Church of England retained the essential form and matter, she ordained, changed, or abolished some of those ceremonies and rites of the Church which were ordained only by man's authority, so that all things might be done to edifying, and rendered more conformable with primitive usage.

The form and offices for making Deacons agree in containing a Prayer *Ad ordinandum Diaconum*, *oremus dilectissimi*, a Prayer for the Holy Spirit, *Exaudi Domine*, an address for united Prayer for the deacon, *Ad consummandum Diaconum*, *Commune votum*, and a Benediction, *Domine Sancte Spei*. The delivery of the stole and Gospel, and other ceremonials, were of later introduction.

Diaconus cum ordinatur, solus Episcopus qui cum benedict manum super caput illius quia non ad sacerdotium sed ad ministerium consecratur [IV. Council of Carthage, ap. Morin, p. 260].

Sacramentary of St. Leo [Migne, p. 260].

Domine Deus, preces nostras clementer exaudi (C).

Oremus dilectissimi (a).

Deus Consolator.

Adesto quæsumus (B).

Sacramentary of Gelasius [Morin, p. 267].

Ordination.

Ad ordinand. Diac. Oremus dilectissimi (a).

Exaudi, Domine Deus, preces nostras (C).

Consecration—Adesto quæsumus (B).

Ad consummandum—Commune votum (γ).

Benediction—Domine Sancte Spei (δ).

Sacramentary of P. Gregory.

Presentation by the Archdeacon.

Address to the people—*Auxiliante Domino* (φ).

The Litany (χ).

Ordination with laying on of hands.

Prayer—*Oremus dilectissimi* (a).

Prayer for the Holy Spirit—*Exaudi Domine Deus* (C).

Consecration—Adesto quæsumus (B).

Investiture with the stole (ε).

Liturgia Alemannica [Gerberti, 40, 9th century].

Ordination.

Benedictio—Oremus dilectissimi (a).

Exaudi Domine (E).

Consecratio, Adesto quæsumus . . . honorum Dator (B).

Gallican Liturgy. Deacon [Muratori, 664; Migne, xxii, 320].

Allocutio ad populum, ending Si vestra apud meam concordat electio testimonium quod vultis vocis adprobate. Per Dominum.

Oratio—Oremus dilectissimi (a).

Consecratio—Adesto quæsumus (B).

Exaudi Domine (E).

Ad consummandum Diaconi officium—Commune votum (γ).

Benedictio—Domine Sancte Spei.

Pontifical [Claudius A. iii. 42 (Cotton MS.), of the 10th century].

Oratio ad ordinandum Diaconi—Oremus dilectissimi (a).

Exaudi, Domine, preces nostras (C).

Domine Deus omnipotens.

Consecratio—Adesto quæsumus omnipotens Deus honorum Dator (B).

Ad consummandum Diaconi officium—Commune votum (γ).

Benedictio—Domine Sancte Spei (δ).

Investiture with stole (ε).

Consecration of the deacon's hands with oil and chrism.

The Mass.

Pontifical of Egbert.

Address by the Bishop—*Auxiliante Domino* (φ).

The Litany (χ).

Investiture with stole.
 Delivery of the Gospel.
 Ordination of the Deacon with laying on of hands by the Bishop.
 Benediction of the Deacon—Oremus, dilectissimi (a).
 (alia) Exaudi, Domine (ζ).
 Consecration of the Deacon—Prayer for the Holy Spirit, Adesto, quæsumus (β).
 Collect ad conservandum diaconatus officii, Commune votum (γ).
 Benediction—A Prayer referring to St. Stephen: Domine Sancte Spei (δ).
 Consecration of the hands of the Deacon with holy oil and chrism.

DEACON [*Harl. MS.* 2906, fo. 8, 10th century].

Presentation by the Archdeacon (α).
 The Gospel is read.
 Si quis.
 Litany (χ).
 Ordination by the Bishop only.
 Commune votum—Address to the people (γ).
 Præfatio Oremus dilectissimi (α).
 Consecratio—Adesto quæsumus (β).
 Delivery of the stole.
 Prayer for the Deacon with allusion to St. Stephen.

Deacons.

Deacons and Subdeacons approach together with their habits
 [Bangor also] [separately Winchester and Exeter] (μ).
 The Litany [omitted by Winton Pont.] (χ).
 The Deacons retire. The Bishop's address.
 Diaconum oportet [a longer form in Winton Pont.].
 Ordination by the Bishop, saying, Accipe Spiritum Sanctum [the form omitted in Winton Pont.].
 Præfatio—Oremus, dilectissimi (a).
 Exaudi Domino (ζ).
 Vere Dignum, with a prayer in it for the Holy Ghost—Emitte in cor Spiritum Sanctum.
 Investiture with the stole.
 [A long prayer in Winton Pontifical.]
 [The delivery of the Gospels.]
 [Commune votum] (γ).
 [Domine Sancte, Pater Spei] (δ).
 Delivery of the Gospels × ×.
 Domine Sancte, Pater fidei spei, etc. (δ)
 Delivery of the dalmatic.
 Reading of the Gospels by a newly-ordained Deacon. oo

1549, 1552, 1662.

Presentation to the Bishop (μ).
 Address to the people [Præfatio a. ζ. γ].
 Litany (χ).
 Holy Communion.
 Collect—Almighty God, Who by Thy Divine Providence.
 [Consecratio] (β).
 The Epistle, I Tim. iii. 8, or Acts vi. 2.
 Examination of Candidates.
 Ordination by the Bishop.
 Delivery of the Gospel × ×.
 The Gospel, St. Luke xii. 35, read by a Deacon oo.
 Collect—Almighty God, Giver of all good [ad consummandum] (δ).
 Prevent us, O Lord [added 1662].
 Benediction [added 1662].

Ordering of Priests.

The earliest services agree in containing a prayer, ad ordinandum Presbyterum, called the *Preface* in the Salisbury Pontifical; the *Consecratio* corresponding to the Collect, "Almighty God, Giver of all good things;" the *Consummatio*, a final Collect, and the *Benedictio*. The Prayer for the giving of the Holy Ghost was about the 10th century added to the proper Preface of the Mass Vere dignum, and after the 12th century took the direct form—"Receive the Holy Ghost," and in some Pontificals the Vere dignum is directed to be left out. As early as the time of

Pope Gregory there was an investiture with the chasuble; and in the 10th century a delivery of the chalice and paten, and a change in the arrangement of the stole: the Consecration of the hands occurs in the Gregorian Sacramentary, and of the head in the Pontifical of Egbert. The arrangement of the chasuble, and the introduction of the Hymn, "Veni, Creator Spiritus," were far later insertions.

Presbyter cum ordinatur Episcopo eum benedicente et manum super caput ejus tenente, etiam omnes Presbyteri qui præsentés sunt manus suas juxta manum Episcopi super caput illius teneant [IV. Counc. of Carthage].

Sacramentary of Pope Leo [Migne, 55. 115].

Oremus, dilectissimi (β).
 Exaudi nos (γ).
 Domine Sancte (α).

Sacramentary of Gelasius [Morin, 267].

Priest.

Si quis.
 Litany.
 Ordination by the Bishop.
 Ad ordinandum Presbyterum—Oremus, dilectissimi (β).
 Exaudi nos (γ).
 Consecratio—Domine Sancte, Pater omnipotens æterne Deus honorum, etc. (α).
 Consummatio—Sit nobis fratres communis oratio (δ).
 Benedictio—Sanctificationum omnium Autor (φ).

Gregory's Sacramentary.

Priest.

Presentation by the Archdeacon.
 Litany.
 Ordination with laying on of hands.
 Prayer for blessing on the Priest—Oremus, dilectissimi (β).
 Prayer for the Holy Ghost—Exaudi nos, quæsumus (γ).
 Consecratio—Domine Sancte (α).
 Investiture with the chasuble.
 Consecration of the hands (ζ).

Gallican Liturgy [Muratori, 666; Migne, lxxii. 521].

Allocutio ad populum ending, Ideo electionem vestram debetis voce publica profiteri.
 Oratio—Oremus, dilectissimi (β).
 Exaudi nos (γ).
 Consecratio—Domine Sancte . . . honorum, etc. (α)
 Consummatio—Sit nobis patres communis oratio (δ).
 Benedictio—Deus Sanctificationum (φ).

MS. Pontifical [Claud. A. iii.].

Priest.

Ordination.
 Oratio ad Ordinandum Presbyterum.
 Oremus, dilectissimi (β).
 Exaudi quæsumus, Domine Deus (γ).
 The stole is changed. *Consecratio* (α).
 Domine Sancte Pater omnipotens æterne. Dispositor honorum, etc.
 Consecration of the Priest's hands with chrism, with prayer, and of his head with oil.
 Investiture with the chasuble (ε).
 Consecratio—Presbyteri, Sit nobis communis oratio (δ).
 The Mass.

Pontifical of Egbert [735—766].

Investiture with the stole, with a prayer.
 Mention of the title on which the Priest is ordained.
 Ordination by laying on of the hands of the Bishop and Priests, with a prayer.
 Oratio ad Presbyterum ordinandum—Oremus, dilectissimi (β).
 Exaudi nos (γ).
 Consecration of the Priest—Domine Sancte, Pater omnipotens (α).

Oratio—Sit nobis communis oratio (δ).

Benediction of the Priest—Deus Sanctificationum (φ).

Investiture with the chasuble (ε).

Consecration of the hands with chrism in the shape of (ζ) a cross, and of the head of the Priest with oil.

Liturgia Alemannica, 9th century [Gerberti, 41].

Ordination—The Priests holding their hands next the Bishop's hands.

Benedictio—Oremus, dilectissimi (β).

Consecratio—Domine Sancte (α).

Consecration of the hands.

PRIEST [Harl. 2906, 10th century].

Presentation by two Deacons and two Priests

Ordination by Bishop and Priests.

Quoniam, dilectissimi.

Address to the people.

Preface—Oremus, dilectissimi (β).

Exaudi nos (γ).

Vere dignum, with Æterne Deus honorum dator (α).

Investiture with stole.

Benediction—Deus Sanctificationum (φ).

Cruciform unction of both hands (ζ).

Delivery of paten and chalice.

Benediction.

Salisbury.—Priests.

Presentation by Archdeacon.

Duties of Priesthood explained—Sacerdotem oportet.

[A long address by the Bishop. Winton Pontif.]

Ordination by the Bishop in silence, the Priests assisting.

Prefatio Sacerdotum cum nota stando, Oremus, dilectissimi (β).

[In the Exeter Pontifical is the Populi Communitio, Commune votum.]

Exaudi nos, quæsumus.

Vere dignum, with prayer for the Priests.

Investiture with stole and chasuble.

Consecration of the hands with oil and chrism.

Oratio—Deus Sanctificationum omnium (φ).

The Hymn, "Veni, Creator Spiritus" [omitted in Winton Pontifical].

Blessing of the hands.

Delivery of the paten and chalice.

[In the Winton Pontifical Consummatio—Sit nobis.

Communis oratio (δ).

Deus Sanctificationum (φ).

The Benediction.]

The Mass—After the Post-Communion.

The ordination by the Bishop—Accipe Spiritum Sanctum.

Arrangement of the chasuble. [This is found also in the Greek

Euchologium, where "the Bread" is put into the hand of the newly ordained Priest. The Deacon has a flapper delivered to him. Assemanni, xi. 132.]

Benediction.

1549, 1552, 1662.

Sermon or Exhortation.

1662 { Præsentation by the Archdeacon.

Address to the people.

The Litany.

Collect—Almighty God [the Consecration (α) and Preface].

Epistle, Eph. iv. 7 [Acts xx.; 1 Tim. iii., 1552].

The Gospel, Matt. ix. 36 [Matt. xxviii., 1552].

John x. 1 [and John xx., 1552].

Address to the Candidates } [after the Veni, Creator,

Prayer for them. } 1552.]

Veni, Creator [after the Gospel, 1552].

Prayer—Almighty God [Benediction (φ)].

Ordination by the Bishop, the Priests assisting.

Delivery of the Bible.

After the
Veni, Creator,
1552.

Collect—Most Merciful Father [Consummatio] (δ).

Prevent us, O Lord [1662].

The Benediction [1662].

CONSECRATION OF BISHOPS.

The offices for consecration of a Bishop agree in having a Prayer for the Elect, Oremus, dilectissimi, the Benediction, Adesto supplicationibus, and the Consecration, Deus honorum. The unction appears first in the Sacramentary of Gelasius, and the delivery of the staff in Egbert's Pontifical. A form of enthronization also occurs at an early date.

Episcopus cum ordinatur, duo Episcopi ponant et teneant Evangeliorum codicem supra caput et cervicem ejus, et uno super eum fundente benedictionem reliqui omnes Episcopi qui adsunt manibus suis caput ejus tangant. [IV. Council of Carthage.]

Sacramentary of Pope Leo [Migne, lv. 114].

Exaudi, Domine, supplicum preces (ε).

Suscipe, Domine.

Adesto, Misericors Deus (γ).

Propitiare Deus (α).

Deus honorum omnium (β).

Sacramentary of Gelasius [Morin, 267].

Consecration with laying on of the Gospels.

Oremus, dilectissimi (δ).

Adesto supplicationibus (γ).

Propitiare Domine (α).

Deus honorum omnium (β).

Unction with chrism.

In a very ancient French Pontifical of Poitiers, c. 511—60, printed by Morin.

Exhortation to the people.

Oremus, dilectissimi (δ).

Exaudi, Domine (ε).

Propitiare, Domine (α).

Collect—Deum totius sanctificationis.

Consecratio—Deus honorum omnium (β), containing a prayer for spiritual unction.

Sacram. Gregorii [Migne, lxxviii. p. 223].

Ordination with imposition of hands.

Prayer for the Bishop—Oremus, dilectissimi (δ).

Benediction of the Bishop—Adesto supplicationibus nostris (γ).

Another prayer for the same—Propitiare, etc. (α).

Consecration—Deus honorum omnium (β).

Unction.

Gallican Liturgy [Muratori, 669; Migne, lxxii. 323].

Exhortatio ad populum.

Oratio et preces—Oremus, dilectissimi, the third Prayer in the Ordo Romanus (δ).

Exaudi, Domine (ε).

Propitiare, Domine (α).

Collectio—Deus omnium sanctificationum.

Consecratio—Deus honorum omnium, with a prayer for unction of the Holy Ghost, and for enthronement (β).

Liturgia Alemannica [9th century, Gerberti, 42].

Benedictio—Adesto quæsumus (γ).

Propitiare (α).

Consecratio—Deus honorum, with prayer for the Holy Spirit (β).

Pont. Egberti.

Ordination by one Bishop pronouncing the Benediction, two holding the Gospels over the neck of the ordained, and the rest holding their hands over his head.

Three Prayers { Oremus, dilectissimi (δ).

Adesto supplicationibus (γ).

Propitiare, Domine (α).

Consecration of the hands of the Bishop.

Unction of his head.

Delivery of the pastoral staff and ring.

Prayer ad pontificem ordinandum—Deus honorum omnium (β).
Installation of the Bishop on his throne, with prayer, Omnipotens Pater (ζ).

The Benediction.

Benedictio in consummatione Episcopi. Spiritus Sanctus Septiformis veniat super te, et virtus Altissimi sine peccato custodiat te, et omnis benedictio quæ in Scripturis Sanctis scripta est super te veniat. Confirmet te Deus Pater et Filius et Spiritus Sanctus, ut habeas vitam æternam et vivas in sæcula sæculorum. Amen.

Salisbury Pontifical.

Bishop.

Presentation by two Bishops.

Examination by the Archbishop.

The Mass begun with the Prayer Adesto supplicationibus (γ), to the end of the Sequence.

The Archdeacon robes the Elect.

Two Bishops present him.

Oremus, dilectissimi (δ).

The Litany.

[The Hymn—Veni, Creator] [Winton Pontif.]

The Gospels laid on the head of the Elect [with Accipe Spiritum Sanctum, Exeter Pont.].

Veni, Creator.

Vere Dignum, with the preface for the Bishop Elect. Domine Sancte . . . honor omnium dignitatum (θ).

Unction of the head of the Elect with oil and chrism.

Preface and Prayers for the Elect, for the gifts of the Holy Spirit.

* Pater Sancte, omnipotens Deus (ζ).

Benediction of the Septiform Spirit [occurring also in Pont. Egberti].

Unction of the hands of the Elect.

The delivery of the pastoral staff [also in Pont. Egbert and Dunstan].

The delivery of the ring [also in Pont. Egbert].

The delivery of the mitre.

The delivery of the Gospels.

The Post-Communion.

Greek Euchologium [of the 11th century].

Ordination of a Bishop.

After the Trisagion the Archbishop goes up upon the steps of the Sanctuary before the Holy Table, and receives a letter, stating that by the approbation of the Bishops, Priests, and Deacons, the heavenly grace which healeth the weak and supplieth that which is lacking, promotes this godly Priest N. to be Bishop of the city &, and we therefore pray that the Grace of the Holy Spirit may descend upon him.

The Archdeacon then says, "Attend," and the Patriarch reads the letter; then Kyrie Eleison is said, and the Elect is led up by three Bishops, assistants in the consecration. Then the Patriarch lays the book of the Gospels on his neck, the Bishops touching it; three signs of the cross are made on his head, and the Bishop holding his hand on it says two prayers: he then invests him with the pall; and after enthronization the newly consecrated Bishop communicates the Patriarch. Assemanni [xl. 125].

1549, 1552, 1662.

Communion Office.

Collect—Almighty God.

Epistle [1. Tim. iii. 1].

Acts xx. 17 [1662].

Gospel—John xxi. 15.

John xx. 19 [1662].

John x. [1552].

Matt. xxviii. 18 [1662].

Presentation to the Bishop.

Oath of due Obedience.

Address to the Congregation.

The Litany.

Prayer—Almighty God, Giver of all good things [Consecration] (β).

Address to the Elect.

Interrogation of the Elect.

The Elect robes.

Veni, Creator.

Prayer—Almighty God [Benediction] (γ).

Consecration by three Bishops.

Delivery of the Bible [and of the staff, 1549].

Prayer—Most Merciful Father.

Prevent us [1662].

Benediction [1662].

§ *The Revision of the English Ordinal.*

The first change in the old English Pontificals was made by the omission of the oath of Obedience to the Bishop of Rome by Act 28 Hen. VIII. c. x. In the winter of 1548, a Committee, consisting of the Primate, the Bishops of Rochester, Ely, Lincoln, and Westminster, according to Heylin [Hist. of Reform., pp. 57, 58], the Deans of St. Paul's, Lincoln, Exeter, Ch. Ch., Archdeacon Robertson, and Redmayne, Master of Trinity College, Cambridge, and, as Burnet adds, (Collier inclining to the same belief,) the Archbishop of York, and Bishops of London, Durham, Worcester, Norwich, St. Asaph, Salisbury, Coventry, Carlisle, Bristol, and St. David's [Burnet, Hist. of the Reform. pt. ii. b. i., and Collier, Eccles. Hist. pt. ii. b. iv.], was appointed to reconstruct an Ordinal. The old books of Ecclesiastical offices had been destroyed ruthlessly and needlessly by the King's orders [Cardwell, Doc. Ann., No. xx.]; and therefore, in November, 1549, the Parliament made an Act, declaring that "forasmuch as concord and unity to be had within the King's Majesty's dominions, it is requisite to have one uniform fashion and manner for making and consecrating of bishops, priests, and deacons, or ministers of the Church: Be it therefore enacted by the King's Highness, with the assent of the Lords spiritual and temporal, and the Commons in this present Parliament assembled, and by the authority of the same, that such form and manner of making and consecrating of archbishops, bishops, priests, deacons, and other ministers of the Church, as by six prelates and six other men of this realm, learned in God's law, by the King's Majesty to be appointed and assigned, or by the most number of them, shall be devised for that purpose, and set forth under the Great Seal of England before the 1st day of April next coming, shall by virtue of the present Act be lawfully exercised and used, and none other, any statute or law or usage to the contrary in any wise notwithstanding" [3 and 4 Edw. VI. c. xii.]. In the House of Lords, the Bishops of Durham, Chichester, Carlisle, Worcester, and Westminster, protested against the Act [Burnet, pt. ii. b. i.]. Cranmer had the chief hand of the work [Strype's Mem. of Cranmer, ch. xi.], and, it is said, drew up the preface. Three offices only were prepared, although the Statute had mentioned the ordering of *other Ministers* of the Church, that is, clergy in minor orders, Subdeacons and Readers, &c. It was providential that the counsels of the more moderate party in the Church prevailed over the rash advice of the intemperate and Germanizing section, who would have abolished much that was of ancient use. Poynt wished to abandon the very name of Bishop. Grindal called it the mummery of consecration. Jewel would have had no clerical dress, and Hooper would not wear it. In the new form the unction of the Priest's hands, a French rite in the sixth century, unknown in the Greek Church, and not practised at Rome until after the time of Nicholas I., was laid aside, as was also the blessing of the Priest's habit with a special blessing for his offering acceptable sacrifices, a ceremonial not of earlier date than the eighth century. But the delivery of the chalice, or cup with the bread, which had been practised in the tenth century, was retained. It may be observed, that under the Law certain portions of the offertory were placed in the hands of Aaron and of his sons, symbolically of their office of presenting the sacrifices before the Lord [Exod. xxix. 24]. The Service began with an Exhortation; and one of the following Psalms, xl., cxxxii., and cxxxv., at the discretion of the celebrant, was to be sung as the introtit to the Holy Communion. For the Epistle was appointed Acts xx. 17—35, or else 1 Tim. iii. 1. 8; for the Gospel, Matt. xxviii. 18 to the end, or John x. 1—16, or John

xx. 19—23. The *Veni Creator* having been sung, the Deacon was presented by the Archdeacon. Then followed the Litany with a special Collect. The Deacon to be ordained Priest was to have a plain albe upon him; the dress appointed for the candidate for Deacon's orders, with the addition of the word "white." The oath of the King's supremacy was administered, and the Exhortation made by the Bishop, who proceeded to put a series of questions copied literally in part, and wholly in spirit, from the interrogatories made in the Elder Pontificals to Bishops; after a certain space kept in silence for prayers by the congregation, the Bishop, having said a prayer, ordained the Deacon to the Priesthood, and delivered to him the Bible; the Holy Communion followed, with a special Prayer before the Benediction. In the ordering of Deacons, the order was as in the present Form.

In the Litany, however, three of the petitions ran thus:—"From all sedition and privy conspiracy, from the tyranny of the Bishop of Rome and all his detestable enormities," &c. "That it may please Thee to illuminate all Bishops, Priests, and Ministers of the Church," &c. "That it may please Thee to bless these men, and send Thy grace upon them, that they may duly execute the office now to be committed unto them to the edifying of Thy Church, and to Thy honour, praise, and glory." The Epistle was 1 Tim. iii. 8—16, or Acts vi. 2. The oath of the King's supremacy was much longer, and in a different form. The newly-appointed Deacon was to "read the Gospel of that day, putting on a tunicle." If Deacons and Priests were ordained at the same time, the whole of the three chapters of the First Epistle to Timothy was read. In the form of consecrating an Archbishop or Bishop, the Psalm for the introit at the Holy Communion was to be the same as at the ordering of Priests. The Epistle was 1 Tim. iii. 1, and the Gospel, John xxi. 15, or "chap. x., as in the order of Priests." At the presentation, the elected Bishop was to have upon him a surplice and cope, and the presenting Bishops to be in surplices and copes, and bearing their pastoral staves in their hands. The Archbishop laid the Bible on the neck of the consecrated Bishop, and put the staff into his hand, saying, "Be to the flock," &c.

This complete Form and Manner was published in March, 1549-1550, and printed by Richard Grafton, Printer to the King, and five Bishops were consecrated according to it. Unhappily the efforts of the extreme reformers prevailed now over the better judgment of the Catholic party. The influence of Peter Martyr, Alasco, Bucer, and Calvin was felt in the counsels of Hooper, Poynt, and their followers. In consequence of their representations, a new review was instituted in the commencement of 1551; and on and after All Saints' Day, 1552, the Second Book of Edward VI. was ordered to be in use. The handiwork of violent men of factious, peevish, and perverse spirit is only too recognizable, "betraying their own folly," and "full of innovations and newfangledness." Several laudable practices of the Church of England, or indeed of the whole Catholic Church of Christ, were now laid aside. The introits of the Holy Communion, the habits of the candidates and of the presenting and electing Bishops, the delivery of the chalice and sacred elements, and of the pastoral staff, was omitted, and only one change was made for the better at the instance of Hooper, the substitution in the oath of the King's supremacy of the words, *So help me God, through Jesus Christ, for all Saints and the holy Evangelists*. By statute 5 and 6 Edw. VI. cap. i. § 45, the form and manner of making and consecrating of Archbishops, Bishops, Priests, and Deacons, was annexed to the Book of Common Prayer, "faithfully and godly perused, explained, and made fully perfect." This Act passed the House of Commons, and was returned to the Lords, April 14, 1552 [Collier, *Eccles. Hist.* p. iv. b. ii. Burnet, p. ii. b. i.], and the 35th of the Articles drawn up in 1552 by a Committee delegated by both Houses of Convocation, and in force until 6 Eliz., declares that the book of the Ordering of the Ministers of the Church, for truth of doctrine is godly, and in nothing is repugnant to the sound doctrine of the Gospel, but agreeth thereto, and doth much promote and illustrate the same. The 25th Article, entitled, "*Nemo in Ecclesia ministrat nisi vocatus*," is literally the same as the 23rd in the Articles of Religion of 1562. Only one Bishop was consecrated according to this Ordinal.

Out of twenty-six sees twenty were still occupied by Bishops who had been consecrated according to the use of the old Pontificals: upon the accession of Queen Mary, the Acts of 3 Edw. VI. c. xii., for drawing up the Ordinal, and 5 Edw. VI. c. i., for annexing it to the Book of Common Prayer, were repealed; and after December 20, 1553, the forms commonly used in England in the last year of King Henry VIII. were only to be used. An unanswerable testimony that the main body and essentials, as well in the chiefest materials as in the frame and order thereof, had been continued the same in the Reformed Ordinal, is contained in the fact that the Roman party contented themselves with requiring "the supply of those things wanted before," such as unction and the delivery of sacred vessels and of the proper habits [Art. xv. 1553. Burnet, pt. ii. b. ii.], and so reconciling the Ministers ordained according to the new form [Cardw., Doc. Ann., No. xxx. Heylin's *Hist. of the Reform.*, p. 206], and Pope Julius in his Bull, 1553, giving Legatine power to Cardinal Pole, desired him to reconcile and reinstate the Bishops and Archbishops in their Cathedral Churches, and permit them to ordain to the priesthood,—*ad quoscunque etiam sacros et Presbyteratus ordines promovere et in illis aut per eos jam licet minus rectè susceptis ordinibus, etiam in altaris ministerio ministrare necnon munus consecrationis suscipere* [Cardw., Doc. Ann. xxxii.]. It will be borne in mind that these subsidiary rites and ceremonies, as well be shown on a later page, are regarded by Roman Catholic Canonists of the first rank and eminence to be wholly unessential and of very late introduction. On June 13, 1558, every copy of the English Ordinal was required to be delivered up to the Ordinary of the diocese [Cardwell, No. xxxix.]. Thirteen Bishops were consecrated during the imprisonment of the Primate Cranmer, and as many were irregularly intruded into sees not vacant [Burnet, pt. ii. b. ii. Heylin, p. 208] by the authority of the Pope, which had been renounced by the Provincial Synods of Canterbury and York, as well as by individual dioceses. In November, 1558, Queen Mary and Cardinal Pole died.

On the accession of Queen Elizabeth the Second Book of Edward VI. with the Ordinal having been reviewed by Parker, Cox, Pilkington, Grindal, Sandys, Guest, May, Bill, and Smith, was restored by Act of Parliament, April 20, 1 Eliz. c. ii. § 3, to be in force and effect after June 24, and the Act of Repeal passed in Queen Mary's reign was annulled. On December 17, 1559, at Lambeth Chapel, Parker was consecrated to the arch-see of Canterbury by the Bishops of Chichester, Bedford, and Exeter. The Ordinal had been included under the "words of Administration of Sacraments, Rites, and Ceremonies," but Bp. Bonner objected that it was not expressly named, although of course it formed an integral part of the Book of Common Prayer by statute of 1552, and had been repealed together with it in 1553. However, to put an end to all such exceptions, an Act was passed September 13, 1566, 8 Eliz. cap. i. § 3, 5, confirmed by 1 Jac. I. c. xxv. § 48, authorizing the use of the Ordinal in future, and declaring that all persons that had been or should be made, ordered, or consecrated by it were true Archbishops, Bishops, Priests, and Deacons. But the XXXVth Article of Religion, drawn up in 1562, and confirmed by Convocation, 1571, had already decreed the validity of all orders conferred according to the new Ordinal since the second year of Edward VI., and the Act, 13 Eliz. c. xii., required subscription to those Articles by the Clergy; the Constitutions Ecclesiastical, 1575, further required that Holy Orders should be given only according to the form and manner of the Ordinal; and in those of 1604 [c. xxxvi.] all impugnors of the Ordinal were declared excommunicate, and all candidates for the ministry required to acknowledge its conformity with the Word of God. Courayer mentions the important fact that Pope Pius IV. by his envoy offered to confirm the whole English Prayer Book, of course including the Ordinal, provided the Church of England would be reconciled to the Pope and acknowledge his supremacy [ch. xiii. p. 235]. In 1640, when a complete Pontifical was to have been drawn up, the form of Ordering Bishops, Priests, and Deacons was to have been retained [Heylin, *Cypr. Anglic.* pt. ii. p. 414]. In January, 1645, the Book of Common Prayer was proscribed.

On March 25, 1661, by royal commission, King Charles II. empowered Conferences to be held for a "review of the Book of Common Prayer, comparing the same with the most ancient Liturgies which have been used in the primitive and purest times." Bishops Cosin, Wren, Sanderson, Nicholson, Morley, HENCHMAN, Skinner, and Warner proceeded to undertake the work, assisted by the MS. notes of Bishops Cosin, Overal, and Andrewes. On November 29, the Upper House were still at work upon the revision of the Ordinal; on December 20, 1661, the Book was received, approved, and subscribed by both Houses. On May 19, 1662, the Bill for the Uniformity of Public Prayers and Administration of the Sacraments received the Royal Assent, and provided that the new Book should be used after the Feast of St. Bartholomew, 1662 [13 & 14 Car. II. c. iv. § 32]. It was authorized again by Act, 1706, 5 Ann. c. v. viii. art. xxv. § vii.

The alterations, additions, and variations were chiefly made in rubrics for the better direction of those officiating in the Service, in a clearer explanation of some words and phrases, and rendering the Epistles and Gospels according to the last translation. The former were numerous and of greater significance and importance. In the *Ordering of Deacons* the words, "After Morning Prayer is ended there shall be a Sermon or," were added in the first rubric. The Bishop was required to be sitting in his chair near to the Holy Table, whilst the candidates were once more directed to be decently habited, that is in the habit and apparel suitable to the order to which they were to be ordained,— "the vestures appointed for their ministry," a plain albe or surplice, with a cope for Priests, and albes with tunicles for Deacons, were appointed, in the first Prayer Book of Edward VI. This rubric therefore restored in spirit that of the first Prayer Book of Edward VI., whilst it was opposed to the old custom of investiture of the candidates by the Bishop's own hands. In the Litany the word "rebellion" was substituted for the passage, "from the tyranny of the Bishop of Rome and his detestable enormities;" "Bishops, Priests, and Deacons," for the vague wording, "Bishops, pastors, and ministers of the Church;" and for "to bless these men and send," &c., "these Thy servants now to be admitted to the order of Deacons, and to pour Thy grace upon them." The Prayer of St. Chrysostom was omitted. This rubric was now added, "then shall be sung or said the Service for the Communion, with the Collect, Gospel, and Epistle as followeth." The candidate was desired to "*humbly kneel before the Bishop.*" At the delivery of the Gospel, the words "thereto licensed by the Bishop himself," were substituted for "*thereunto ordinarily commanded.*" Instead of the Gospel of the day, a proper Gospel was enjoined; and the Collect, "Prevent us, O Lord," was added from the Post-Communion Office. In the address on the duties of a Deacon, the words "to baptize" were enlarged into these, "in the absence of the Priest, to baptize infants;" and the sentence "they may be relieved by the parish or other convenient alms," was altered to "relieved with the alms of the parishioners or others."

The Ordering of Priests. The form hitherto began with the Service for the Holy Communion; after an Exhortation and the presentation of the Candidates, followed the singing of the Veni Creator, but it was now removed to the beginning of the Service in a manner like that for the Ordering of Deacons. For the Epistle of 1552, Acts xx. 17—35, or 1 Tim. iii., transferred to the Consecration of Bishops, because the *πρεσβύτεροι* mentioned therein were the Bishops of Asia Minor [St. Chrysostom, Hom. xi. 1. Theodoret in 1 Tim. iv. 14. Cœcumenius, Comm. in 1 Tim. c. xiii. Theophylact in 1 Ep. ad Tim. iv. 14. Suicer, Thes. Eccles. ii. p. 824. Aquinas, Comm. cap. iv. § 3], Eph. iv. 7 was appointed. The Gospel, Matt. xxviii. 18—20, now the appropriate third Gospel for the Consecration of Bishops, was exchanged for Matt. ix. 36, and the third Gospel, John xx., was removed to that Service also. Another translation of the hymn, Veni Creator, probably made by Dryden, was added. The words "for the office and work of a Priest in the Church of God now committed unto thee by the imposition of our hands," were inserted after the words "Receive the Holy Ghost," in order to determine the Ordination to the Priesthood. The old rubric was

ambiguous: "if the Orders of Deacon and Priesthood be given both upon one day, then shall all things at the Holy Communion be used as they are appointed at the Ordering of Priests, saving that for the Epistle the whole of 1 Tim. iii. shall be read as it is set out before in the Ordering of Priests, and immediately after the Epistle, the Deacons shall be ordered, and it shall suffice the Litany be said once." It was now expanded into a fuller and clearer shape: "And if on the same day the Orders of Deacons be given to some, and the Order of Priesthood to others, the Deacons shall be first presented and then the Priests, and it shall suffice that the Litany be once said for both. The Collects shall both be used, first that for Deacons, then that for Priests. The Epistle shall be Eph. iv. 7—13, as before in this Office. Immediately after which they that are to be made Deacons shall take the Oath of Supremacy, be examined and ordained as is above prescribed. Then one of them having read the Gospel, which shall be either out of Matt. ix. 36—38, as before in this Office, or else Luke xii. 35—38, as before in the form for Ordering of Deacons, they that are to be made Priests shall likewise take the Oath of Supremacy, be examined and ordained as in this Office is before explained."

Consecration of a Bishop. In place of the old title and rubric, "The form of Consecrating of an Archbishop or Bishop," these were added, "The form of Ordaining or Consecrating of an Archbishop or Bishop, which is always to be performed on some Sunday or Holyday." "When all things are duly prepared in the Church and set in order." "After Morning Prayer is ended, the Archbishop, or some other Bishop appointed, shall begin the Communion Service, in which this shall be the Collect," the latter containing a slight alteration of the Collect for St. Peter's day, the name of that Apostle being omitted. The word *ordaining* was added to show the distinction between the Orders of Priest and Bishop, and the ceremonial was directed to take place on a Sunday or Festival, a special collect being added. The Epistle, Acts xx. 17, with the rubric, "And another Bishop shall read the Epistle," was added, and the Gospel, John xx. 19 (in place of "John x., as in the Ordering of Priests"), or Matt. xxviii. 18, with the rubric, "Then another Bishop shall read the Gospel," was inserted; thus securing the presence of at least three Bishops, the Canonical number, and the reading of appropriate passages of Holy Scripture. The former rubric, "After the Gospel and Credo ended, first the elected Bishop shall be presented by two Bishops unto the Archbishop of that province, or to some other Bishop appointed by his commission, the Bishops that present him saying," was amplified thus, "After the Gospel and Nicene Creed and the Sermon are ended, the elected Bishop, *vested with his rochet*, shall be presented by two Bishops unto the Archbishop of that province, or to some other Bishop appointed by *lawful commission*, the Archbishop sitting in his chair near the Holy Table, and the Bishops that present him saying." A provision was thus made for a proper habit to be worn by the Elect, for the proper position of the Archbishop, and for the appointment of his representative in case of his illness or death. In the next rubric the words "person elected" were changed into "persons elected." In the Litany the rubric was altered from "he shall say," to "the proper suffrage there following shall be omitted, and this inserted instead of it." In the address to the Elect the words "to the government of the congregation of Christ," were altered to "government in the Church of Christ." After the sixth question, was inserted a new interrogatory, "Will you be faithful in ordaining, sending, or laying hands upon others? *Answer.* I will so be, by the help of God." After these questions, for the words "the Archbishop," the rubric was added, "*then the Archbishop, standing up, shall say;*" and for the rubric "then shall be sung or said, Come, Holy Ghost," another was substituted, "Then shall the Bishop Elect put on the rest of the Episcopal habit, and kneeling down, Veni Creator Spiritus shall be sung or said over him, the Archbishop beginning, and the Bishops with others that are present answering by verses as followeth." In the rubric preceding the Consecration the words, "*kneeling before them on his knees,*" were added after "the elected Bishop;" and for the form, "Take the Holy

Ghost, and remember that thou stir up the grace of God which is in thee by imposition of hands, for God hath not given us the spirit of fear, but of power, and love, and of soberness," another was ordered: "Receive the Holy Ghost for the office and work of a Bishop in the Church of God, now committed unto thee by the imposition of our hands, in the name of the Father, and of the Son, and of the Holy Ghost. Amen. And remember," &c., thus emphatically marking the consecration to the Episcopate. The words "with other," were changed into "with others" who were to communicate with the new-consecrated Bishop; and "after the last Collect" to "for the last Collect," "Prevent us, O Lord," being inserted before the Benediction.

Such is the history of the great revision of the Ordinal of 1662. Some ceremonies were with reverence restored in conformity with ancient precedents; many improvements were made, and certain reconstructions to secure greater conformity in the services were carried out. In the year 1689 some insidious designs against the integrity of the Ordinal were set on foot; but, under God's good providence, frustrated. With some few variations, it is in use in that great branch of the Catholic Church founded in the United States of America, and in the sister Churches of Ireland and Scotland it has been preserved in its complete form.

§ The Essentials of Ordination.

The Greek words for Ordination were *τελειούν, ἀγιάζειν* [Johnson's Unbl. Sac. ch. ii. sect. 1], and *τελειουργία, καθιέρωσις* [Zonaras in I. Can. Apost.], and, by Dionysius, *ιερατική τελείωσις*, but almost universally *χειροτονία* in the sense both of Election [I Conc. Nicæn. A.D. 325, c. iv. I Conc. Antioch, A.D. 341, c. xix., and Laodicæa, A.D. 365, c. v. 2 Cor. viii. 19, as the Jewish Judges of Consistories and the public Magistrates of Athens were chosen by a show of hands] and of Ordination by laying on of hands [Acts xiv. 23. 1 Tim. iv. 14. 2 Tim. i. 6]. But the latter is almost wholly and certainly the proper sense in which it was applied. [St. Hieron., Comm. in Esai. c. lviii. Conc. Neo-Cæsar. c. ix. A.D. 314. Ancyra, c. 314, c. x. 2 Conc. Nic. c. xiv. St. Basil, Ep. ad Amph. c. x. St. Chrys. in Ep. ad Tit. c. i. Hom. ii. in Ep. ad Phil.] The word *χειροθεσία*, employed by the Council of Antioch, c. 341, c. x., and the 2^d Council of Nicæa, c. 4, means benediction of the ordained; *ἐπίθεσις τῶν χειρῶν*, which expresses the actual ceremony or matter of Ordination, is a mere synonym for *χειροτονία*. The laying on of the Bishop's hands is the only essential rite of Ordination, being of Apostolical origin, having Scriptural authority, and being that ceremony which has prevailed in all ages and among all branches of the Catholic Church. [Inst. Calvini, lib. ix. c. iii. § 16. Reform. Leg. Eccles. de Sac. c. vi. Becan. de Sacram. c. xxvi. qu. iv. § 6.] Laying on of hands was the action used in blessing among the Jews [Gen. xlviii. 14], and was employed by our Saviour [Mark x. 16], and also in the consecration of Priests [Numb. xxvii. 18, 19. Deut. xxxiv. 9. Numb. viii. 10. Exod. viii. 6, 7], the hand being symbolical of Divine aid [Ps. lxxxix. 21, 22. Ezek. iii. 14]. Our Lord used the incommunicable ceremony of Breathing, as the Author of the heavenly gift, and as showing that the assistance of the Holy Ghost, which proceedeth from Him alone, could make efficient ministers of the New Testament, and would be given to them for their spiritual work. But as He ascended He laid on His uplifted hands and blessed His Apostles [Luke xxiii. 50], and this significant action was adopted by them as symbolical of Divine protection, and a token of delegated and spiritual power. Thus St. Paul and St. Barnabas were ordained with prayer and the laying on of hands, and are said to be sent forth by the Holy Ghost [Acts xiii. 3]. Thus St. Timothy was consecrated [1 Tim. iv. 14. 2 Tim. i. 6]; thus the Bishops, ordained by the Apostles, are said to have been constituted by the Holy Ghost [Acts xx. 28]. Thus Deacons were ordained [Acts vi. 3], and Priests [1 Tim. v. 22].

This doctrine has been held by Fathers, Councils, and Canonists. [St. Jerome in Esai. lviii. 10. St. Augustine de gest. cpm Euner. § xi.; de Bapt. contr. Donat. c. i. § 2; contr. Ep. Parmen. l. ii. c. 13, § 28. St. Ambrose de Dign. Sacerd.; Comm. in 1 Tim. c. iv.

v. 14. St. Cyprian, Ep. lxxvii. ad Cler. et pleb. Hisp. St. Basil, Ep. ad Amphil. c. I. St. Chrysostom, in cap. xv. Act. Hom. xiv. St. Gregory Nazianzen, Orat. xliii. in laude Basili; 1 Conc. Nicæn. A.D. 325, c. ix.; Antioch, 341, c. x.; IV. Carth. 398, c. iv. ix.; Ancyra, 314, c. x.; Coune. of Mayence, 1549, c. xxxv.; Cologne, 1536, pt. i. c. i.; Trent, 1551, Sess. xiv. c. 3; and by the Reform. Leg. Eccles. de Eccl. p. 99, and by the ritualists Sym. Thess. c. v.; Dionys. Areop.; P. Innoc. i. ad Episc. Maced. Ep. xxii. § 5. St. Thom. Aquinas, Dist. xxiv. qu. ii. act. iii. Estius, l. iv. d. 24, § 1. 24. Juennius de Sac. Q. iii. diss. viii. Habert's Archier. p. 121. Morin de Sac. Ord. pt. iii. Ex. i. c. 1, § 2. Dens. Tract. de Ord. vii. p. 47. Bellarmine de Sac. Ord. lib. i. cix.; de Rom. Pont. lib. i. c. xii. Marianus apenardum. Arcudius de Sac. Ord. l. vi. c. 5. Maldonatus de vii. Sac. qu. iii., &c. See also Prideaux, Validity, pp. 70—82, and my "Ordinal," pp. 248-9, note 1.] The ancient Sacramentaries make mention of no other rite. The Greek Bishops use only the right hand in the ordination of Priests and Deacons; and the same custom was observed, until the sixth century, it would seem, in the Western Church. In the English Church the Bishop lays on both hands, and in the Ordering of Priests, the Priests present, without speaking, lay their hands conjointly with the Bishop on the head of the Deacon as a sign of their approbation and reception of the newly-ordained Priest, to give a proof of previous deliberation, and to guarantee to the Church that the Bishop was acting with competent authority, and that there is no defect in his ministration of the sacred rite. It is a bare ceremony, as in the Greek Church Priests salute the Priests, and Deacons the Deacons who are newly ordained. The transition from the custom of the Eastern to that of the Western Church can readily be traced in the following stages. "In the ordering of a Priest a Bishop, lay thyself thy hand in his hand, the Priests standing by" [Const. Apost. l. viii. c. xvi.]. "This is the form of Ordinations," says Theophilus of Alexandria; "all the Priests agree and choose, then the Bishop examines, and, with the assent of the Priests, ordains in the midst of the Church." The third Canon of the 4th Council of Carthage, A.D. 398, "When a Priest is ordained, the Bishop blesses and holds his hand above his head, and all the Priests hold their hands next the Bishop's hand above his head," is quoted in all the old Sacramentaries up to the twelfth century; but in the Pontifical of Corbey, of that date, the Priests are desired to hold their hands on his shoulder blades; and in a still earlier one of the ninth century and some of the tenth century a distinction was made, the Bishop laying on his hand and the Priests holding theirs elevated [Marteng, l. i. c. viii., art. ix. § 9. Morin, P. ii. p. 280]. The Bishop alone laid on hands in the ordination of Deacons [Martene, u. s. § 1]. The Unction of the Priest's hands, and the delivery of the vessels and habits, were later ceremonies, which at the Reformation were laid aside; in the revised Prayer Book of 1552 the delivery of the chalice and paten and pastoral staff being also discontinued.

The delivery of the Epistle to the Deacon, and of the Holy Bible to the Bishop and Priest, was probably introduced from the East through the Gallican Church, as it was the custom at Constantinople to place the order for the Holy Communion in the hands of the Priest, with the word *Ἄξιος*; and by the Euchologium, the Priest is directed at once to read from the Book of the Liturgy. In the African and Western Churches the Bishop alone received the Bible, but it was at length also given to Priests as being associates of the Bishop in teaching the people and the office of preaching.

The essential words by which Orders are conveyed are Prayer for the grace of the Holy Ghost, with a blessing pronounced on the ordained. Hostiensis and P. Innocent, the chief of Canonists, held that it would be sufficient for the ordainer to say, "Be a Priest," or words to that effect, if the Church had not ordered a prescript form [P. Suavis, Polani. Hist. Conc. Trident. l. vii. art. 6]. For as Pope Innocent says, now that proper forms have been made and enacted by the Church, they must be of necessity observed [ap. Nich. arch. Panorm. Comm. s. ii. pt. i. l. Decret.]. The 4th Council of Carthage makes no mention of the form; while in some of the old Sacramentaries and Pontificals are found a

long prayer or preface called the Consecration, and in others a prayer which was sung, beginning, "Giver of honours, and distributor of orders." Thus, St. Augustine says, "They prayed that the Holy Spirit might come upon them on whom they laid hands, a custom yet observed by the Church in her Bishops; we can receive this gift according to our measure, but certainly cannot shed it upon others; but that this may be done, we invoke God who worketh the same on their behalf over them" [de Trin. l. xv. c. xxvi. § 46]; and St. Ambrose, "The Church, as having true Priests, rightly claims this" [i. e. the Divine Commission]. The gift of the Holy Spirit is the priestly office. [De Pæn. l. i. c. ii. § 7.] So God took of the Spirit which was upon Moses, and put it upon the Seventy. [Numb. xi. 17. 25.] In all this the old aphorism holds true, ἀθροιστην τῆς θεᾶς δὲ χάρις. And in order to receive spiritual strength and grace, in all rituals communion in the Holy Eucharist is required from the new-ordained or consecrated. In the Greek Church the words employed are, "The Divine Grace, which helpeth them that are weak and supplieth that which lacketh, chooseth this godly Subdeacon (or Deacon) to be Deacon (or Priest)" [Euchol. ap. Morin. de Sac. Ord. P. i. p. 79]; and in the Syro-Nestorian, "He is separated, sanctified, perfected, and consecrated to do the ministry of a Deacon in the Church, and the work of a Levite, as did Stephen, in the name of the Father, the Son, and the Holy Ghost." The Church of England makes an express mention of the order to which the Candidate is to be appointed.

For nine hundred years after Christ, there was no express statement of the Church respecting the power of consecrating Christ's Body and Blood in the ordering of Priests. The Greek Church does not give in express terms the power of consecrating the sacred elements, or of absolution; the invocation of the Holy Ghost, a prayer of consecration, and a benediction by the Bishop, constituting her form; but as an equivalent she prays God that the Priest may stand unblameable at His altar, to preach the Gospel of His salvation, to minister [ἐπιρροπῆν] the Word of His truth, to offer to Him gifts and spiritual sacrifices, and to renew His people by the laver of regeneration. The Benediction of the old Pontificals resembled this prayer—"May the blessing of the Father, the Son, and the Holy Ghost, be upon thee, that thou mayest be blessed in the order of Priesthood, and offer propitiatory sacrifices" [hostias]. In the Western Church the power of consecrating the Holy Eucharist was not named until the tenth century, and was not adopted in the Use of Bangor before the close of the thirteenth century; but it is found in the Pontifical of Caetan before A.D. 1000, at the delivery of the paten and elements, and the chalice with wine—"Take the power to offer the Sacrifice to God, and to celebrate Mass in the name of the Lord." The form conveying the power of absolution is later by three hundred years, but was alluded to in the shape of a prayer. In a Pontifical of Mayence of the thirteenth century, however, it occurs, "Receive the Holy Ghost, whose sins ye remit," &c., and in a Pontifical of Rouen, about the next century.

§ The Effect of Ordination.

The laying on of hands and prayer, with the delegation of ministerial order, constituting the essential and necessary form and matter of Ordination, it remains to consider the Divine vocation, and the results of Ordination. It is a sanctification of the person to do certain offices of religion, as in the case of Jeremiah [Jer. i. 5], and St. John Baptist [Luke i. 15], and also the imparting of grace to make the person meet to perform the same. The change of name adopted by St. Paul and St. Peter after their ordination expresses significantly the change of condition, the new honour sanctified by God. But, as St. Jerome says, "Let every one prove himself and so come; ecclesiastical order does not make a Christian" [ad Heliodor. Ep. v. al. 1]. The Candidate is to be called to a high dignity and a weighty office and charge, to be a messenger, watchman, and steward of the Lord. He is to be a worker together with God [2 Cor. vi. 1], and giving no offence in any thing, that the ministry be not blamed; approving himself in all things as the minister of God. He is to be one of that order, of whom it is said, that "he that heareth" them heareth

Christ [Luke x. 16], he is to be God's witness [Luke xxiv. 47, 48], to have power over all the power of the enemy [Luke x. 19], and to exercise a most solemn delegation [John xx. 23]. But he has also to show by his deeds rather than by name, what his profession is, and to apply himself wholly to one thing, the priesthood of the atonement and the ministry of reconciliation; to be one set apart by the most impressive vow at God's altar; to forsake all worldly cares and studies, and to sanctify and fashion his life after the rule and doctrine of Christ; to be a wholesome and godly example and pattern for the people to follow. He, like Moses and Joshua [Exod. iii. 5. Josh. v. 15], is bidden to a nearer access to God than the people [Exod. xxiv. 13, 14]. And who is sufficient for these things? for, as St. Chrysostom argues, from Lev. iv. 3—13; xxi. 17, and Luke xii. 47, as the fault of coming short of God's will is greater in His minister, so a more horrible punishment of neglect will ensue: he wants a great soul and a thousand eyes on every side. [Hom. iii. in c. i. Act.; xxvi. in c. viii. Matt.; de Sacerd. l. vi. c. xi.] The Candidate when ordained will have need of learning, for, as Bishop Jeremy Taylor observed, an ignorant minister is a head without an eye; he requires to be a feeder [1 Pet. v. 2], a leader [John x. 4], an oracle [Mal. ii. 7], sober, grave, affable, firm, patient, long-suffering, kind, unwearied, zealous, and undaunted [2 Cor. vi. 1—10], "never ceasing labour, care, and diligence [Acts xx. 2. 1 Thess. ii. 17] until he has done all that lies in him, according to his bounden duty, to bring all such as are committed to his charge unto that agreement in the faith and knowledge of God, and to that ripeness and perfectness of age in Christ, that there be no place left among them either for error in religion or for viciousness in life."

The Candidate for the Diaconate professes his trust that he is inwardly moved by the Holy Ghost to take upon him that office and ministration, and the Candidate for the Priesthood, that he thinks in his heart that he is truly called, according to the will of our Lord Jesus Christ. Any state of life is said to be that to which God is pleased to call us [Catechism], and St. Theophylact renders τῆ κλήσει [1 Cor. vii. 17—20], as ἐν οὐφ βίῳ καὶ ἐν οὐφ τῶν ματι καὶ πολιτεῖασι. Vocation is twofold: [I.] *Extraordinary*, when God calls men (1) immediately, as was Moses; (2) or by means and intervention of a prophet, as Elisha; (3) before the existence of an Order of Ministers, as Aaron and the tribe of Levi; (4) after the institution of a Ministry, as Samuel and Elias, the Twelve [John vi. 70], and the Seventy, St. Matthias, St. Paul [1 Cor. i. 1. 2 Cor. i. 1. Eph. i. 1. Col. i. 1. Gal. i. 1. Rom. i. 1], and St. Barnabas: and [II.] *Ordinary*, when men call and appoint a Minister in the Church according to the law prescribed by God, as were the Aaronic Priests and Levites; Titus and Timothy, Priests and Deacons of the Apostolical Churches, and now the Bishops, Priests, and Deacons of the Church. But the secret voice of the Holy Ghost does invite individuals [1 Cor. ii. 11. Jer. xi. 20; xvii. 10]; on the one hand, Moses hesitated to accept, on the other, Isaiah sought to receive, a mission, and the Apostle declares that the desire to become a Minister is good [1 Tim. iii. 1]. St. Augustine says, when Mother Church desires our work, "nec elatione avida suscipiatis nec blandiente desidia respuatis sed miti corde obtemperetis Deo" [Ep. xlvi.]. "They who came not were sent," says St. Jerome, "for He saith, they came, and I did not send them. In those who came is the presumption of rashness, in those who are sent the obedience of service" [Prol. in Comm. in St. Matt.].

The natural sense of men required a holy entrance on the Priesthood [Demosthenes contr. Androtion. Plato de Leg. l. vi. § vii.], and the Canonical impediments were read over to the Candidate in the Church during many centuries. "The evenest line of moderation in suits after spiritual functions which may be as ambitiously forborne as prosecuted, is not to follow them without conscience, nor of pride to withdraw ourselves utterly from them." The presence of earthly motives, such as desire of honour, wealth, and reputation, is utterly at variance with a Divine call. "The simple eye" [Matt. vi. 22, 23], "a good intention towards God, is a sign of its existence" [St. Chrysost., Hom. v. in 1 Tim. i. §], as the one end sought is doing His work to His honour, and setting forward the salvation of all men, out of a

good conscience [St. Aug. de Serm. Dom.; Ivo. de Excell. Sacr. Ord.; Calvin de Exter. Med. ad Sal. l. iv. c. iii. § 11]. It is not said to the Candidate, "Have you such an inward perception of such a Divine impulse, that you can distinguish it from all other inward movements by its manner of impressing you?" but, "Do you trust that you are on good grounds persuaded that you have a Divine call, that is, from your serious preparation, your honest intention, your sacred resolution to discharge the duties of the office which you seek?" There is required of necessity no inward, secret, sensible testimony of God's blessed and sanctifying Spirit to a man's soul, nor any strong working of the Spirit of illumination; suffice it that there be inclination of nature, personal abilities, and care of education, without any extraordinary assistance of the Holy Ghost. [See Sanderson, iv. Serm. § 32.] "Here is now that glass wherein thou must behold thyself, and discern whether thou have the Holy Ghost within thee or the spirit of the flesh of man. See that thy works be virtuous and good, consonant to the prescript rule of God's word, savouring and tasting not of the flesh, but of the Spirit, then assure thyself that thou art endued with the Holy Ghost" [Homily on Whitsun-day]. The only sure preservative for such a devotion of life and thought to the work of the Ministry as will ensure its accomplishment, is the perpetual memory of Him Who gave the commission to perform it, of the end for which it was given, and the account we must one day render to the Great Shepherd of the Sheep.

The distinction between Clergy and lay persons is asserted by St. Chrysostom [in Ps. exiii. v. 19, § 4], Tertullian [de Præsc. Hær. c. xli.; de Monog. xi.; de Fuga xi.], St. Ambrose [de Dign. Sacerd. c. iii.], St. Cyprian [Ep. lix. ad Com.], and St. Jerome [adv. Lucif.]. The designation Clergy, κληρος, a lot or inheritance, as in the suffrage "Bless Thine inheritance" [Ps. xvi. 15; lxxiii. 26], is another illustration of the analogy subsisting between the Aaronic and Christian Priesthood [Numb. xxviii. 20. Deut. xviii. 1, 2. St. Jerome, Ep. xxxiv. ad Nepot.], whilst there is also a reference to the circumstance of God overruling the lots in the case of St. Matthias, the first minister ordained by the Apostles [Acts i. 26. St. Aug., Enarr. in Ps. lxxvii. 19. Isidore, Orig. l. vii. c. xii.; de Off. Eccles. l. ii. c. 1.]. The word ἀφορισμός, severance, setting apart, founded on Acts xiii. 2, is also used as a synonym for ordination [Bever. Serm. ii., On the Church].

This distinction rests upon the impression of the indelible Ecclesiastical mark or character, the "charisma certum veritatis," as Ignæus terms it [contr. Hær. l. iv. c. xxxvi. § 2], or as St. Augustine, "Sacramentum Ordinationis suæ" [de Bono Conj. c. xxviii.; contr. Donatist. l. i. c. 1, § 2; contr. Ep. Parmen. l. ii. c. xlii.]. The same doctrine is stated by Bishop Jeremy Taylor [Episc. Assert. s. xii. xxxi. 3], Archbishop Potter [Church Gov. ch. v.], Prideaux [Validity, &c., p. 25], Hooker [Eccles. Pol. b. v. c. lxxvii. § 3], Mason [de Min. Anglic. l. ii. c. xi. § 6], and Bingham [Orig. Eccles. b. xvii. c. ii. § 5]. It is that of the canon law, "Si quis clericus relicto officii sui ordine laicam voluerit agere vitam vel se militiæ tradiderit, excommunicationis pœna feriatur" [Conc. Turon. A.D. 461, c. v.]. "Sanctorum decus honorum quilibet fuerit occasione perceptum manebit omnibus inconvulsam" [VIII. Conc. Orléans. A.D. 653, c. vii.]. "Ordo characterem, i. e., spirituale quoddam signum a cæteris distincturum imprimit in animâ indelebile" [Decr. Eugen. ad Armen. Conc. Flor. A.D. 1439. Comp. Conc. Trident. Sess. xxiii. A.D. 1563, c. iv.]. The Canonists use similar expressions [St. Thom. P. iii. qn. 63. Estius in Sent. Comm. l. iv. dist. i. § 20. Becanus, Ib. § 21; and Lyndewood, Walterus, sub. quæst. Prov. Angl. l. i. tit. 5], and our own Canons, "Semel receptus in Sacrum Ministerium ab eo imposterum non discedet, nec se aut vestitu aut habitu aut in ulla vitæ parte geret pro laico" [Articuli, A.D. 1571], with which Canon lxxvi. of 1604 concurs. This principle is grounded on the analogy of the perpetuity of the priesthood, both of Melchisedec and the Jews, and the Apostles and Clergy of the Primitive Church; on the enduring grace of Holy Baptism; on the self-dedication for life to God; on the fact that God has nowhere signified that the character will expire before death; on the actual unbroken tradition that re-ordination was a sacrilegious and

heretical act, and that in cases even of deposition the exercise of sacred functions was only suspended [cf. Ed. Rev. art. v. Jan. 1849].

Holy Orders are not denied, in a large sense of the word and in another nature, the name of a Sacrament, by the ninth Homily of the English Church; but, as being restricted to a class in the community, as lacking the promise of remission of sins, and not having any visible sign or ceremony ordained of Christ [Art. xxv.], and not being generally necessary to salvation, they are so called in an inferior sense to the two Sacraments of the Gospel. With this reservation, the Church of England regards Orders as a Sacrament, or rather as sacramental. The title of the Book of Common Prayer includes "administration of the Sacraments and other rites and ceremonies of the Church." The Rubric of 1549 provided that "every parishioner shall communicate at the least three times in the year, and shall also receive the Sacraments and other rites according to the order of this Book appointed." Similar language is employed in the Act of Uniformity, 1 Eliz. c. ii., and the Homilies, P. 1. "On Common Prayer and Sacraments:" "Neither Orders nor any other Sacrament else be such Sacraments as Baptism and the Communion are" (p. 316). Melancthon included Ordination among Sacraments [Loc. Theol. tom. i. pp. 233, 234. Comp. Conf. Augsburg, pp. 29, 30]. The greatest English Theologians, however, cautiously guard against any misapprehension of the term Sacrament, on the safe ground that the outward ceremony of breathing has been changed into laying on of hands; that the Form of Words is given "as in the Person of Christ," and not from ourselves; and that the grace given is "gratis data," not "gratum faciens" [Bp. Andrewes, Serm. ix.]; but they still do not withhold the designation of Sacrament, provided that it be not understood as a true or necessary Sacrament [Bp. Jewel, Treat. on Sacr., p. 1225. Def. of Apology, p. ii. p. 459. Archbishop Wake, Expos. of Doctrine, Art. xv. p. 46. Calhill, Ans. to Martiall, p. 229. Bp. Burnet, Vind. of Ord., p. 21. Archbishop Bramhall, Cons. of Bishops, disc. v. Crakanthorp, Def. Eccl. Angl. c. xxx. Bp. Beveridge on Art. xxv.].

From the distinction existing between the clergy and laity is derived the word "Order" [gradus βαθμὸς, ordo rãtus], the state to which the ministers of God are ordained [St. Ambr. de Off. Min. lib. l. c. viii. 25. St. August. de Civ. Dei, l. xix. c. 13. Gabriel Philad. c. ii. St. Leo, Ep. lxxxiv. c. 4. Bp. Jeremy Taylor, Episc. Assert. § xxxi. 1. 3]. The words potestas, officium, honor, dignitas, ἀξία, ἀξίωμα, locus, χώρα, are also synonyms of ordo.

§ The Preface to the Ordinal.

The Preface to the Ordinal sets forth the following statements and principles:—

- I. The Three Orders of the Ministry are Apostolical, and have ever been held in reverent estimation.
- II. That there are proper ages at which Orders should be conferred.
- III. That there are proper times and places for ordination.
- IV. That the Candidates shall be duly tested as to character and qualifications.
- V. That there are indispensable rites and ceremonies ministered by a Bishop for ordination, public prayer with imposition of hands.
 - I. If these three Orders be from the Apostles' times, they must be Divine. The Saviour, as High Priest upon earth, actually ordained His Apostles and seventy disciples as representing Priests and Levites. The first consecration of Apostles is referred to the Holy Ghost [Acts i. 24; xiii. 2], and the ordination of Deacon also, "being full of the Holy Ghost" [vi. 5]. The offices Bishops, Priests, and Deacons are quite clear in the New Testament; but distinct names for the three orders are not discernible at first until language permitted and circumstances demanded it. We find ordainers and persons ordained, and the names Bishops, Priests, and Deacons: even in the second century Presbyters were called Bishops, as overseers of a portion of the flock; but in the third century Bishops are nowhere called Presbyters. The Apostolical fathers distinctly enumerate Bishops, Priests, and Deacons as severally distinct. These orders, on the testimony of ancient authors, evidently existed at all times in Christ's Church,

and must therefore be perpetuated by lawful authority, that is, by Bishops, who alone have the power of ordaining, in order that they may continue and be reverently used and esteemed.

II. The Canon Law defines thirty years to be the Canonical age for the reception of the Priesthood, but suffers the admission of the Candidate at twenty-five years of age. [P. Dist. lxxviii. c. 1, ii. v.] Pope Zosimus, 417, enacted the ages for Priesthood and the Diaconate to be respectively thirty and thirty-five years. [R. Maurus de Ord. Antiph. c. xiii.] Pope Siricius, 385—98, requires the ages to be thirty-five and thirty [Ep. i. § ix.]. The Councils of Agde, A.D. 506, c. xvi. xvii.; III. Carthage, A.D. 397, c. iv.; II. Toledo, A.D. 531, c. i., permitted the reception of the Diaconate at twenty-five years; that of Meff, A.D. 1089, at twenty-four, and the Priesthood at thirty years of age. The latter age is also prescribed by the old Saxon laws, and the Councils of Neo-Cæsarea, A.D. 314, c. xi.; IV. Toledo, A.D. 633, c. xx.; IV. Arles, A.D. 524, c. i., and Trullo, 691, c. xiv. The third Council of Ravenna, A.D. 1314, Rubr. ii., forbids Deacons to be made under twenty, or Priests below twenty-five years of age. The Council of Trent, Sess. xxiii., A.D. 1563, c. xii., permits the ordination of Deacons at twenty-three, and of Priests at twenty-five years of age. In the Greek Church the age for a Deacon is twenty-five [that for Levites in the Jewish Church], for a Priest thirty years [Sym. Thess. c. v. Assemani, P. iv. p. 169]. The latter age is so often prescribed because at it our Lord began His ministry. [St. Luke iii. 23. Excerpt. Ecgbert, 750. Epist. c. xcv. St. Aug., Ep. xxxix. ad Theoph.] In the Ordinal of 1552, the age for the Diaconate was twenty-one, that of the Roman Sub-diaconate; which is still allowed in the American Church (1832) and Scottish Church (1838), twenty-four years of age being required in the candidate for the Priesthood. In 1584, Archbishop Whitgift required twenty-four years of age full in the candidate for orders [Cardw., Doc. Ann., No. xcix.]. In the Apostolical Constitutions the age for a Bishop is at least fifty years [lib. ii. c. 1.], and Pope Boniface, in the eighth century, alludes to this rule; by Justinian [Novell. Constit. 123, c. 1] it is fixed at thirty-five, but in Novell. cxxxvii. c. 2, at thirty; by Siricius and Zosimus forty-five [Theod. H. E. l. ii. c. 26]; but in the Greek Church it is probable that in the cases of St. Athanasius, Gregory Thaumaturgus, Athenodorus [Euseb. H. E. lib. vi. c. 30], Acholius [Ambros. Ep. lx.], Paul [Soc. H. E. lib. c. 5], and in the Western Church, Remigius of Rheims, who are all spoken of as young men, a lower age was sometimes accepted. By the Act 3 Eliz. c. xii. § v. vii., a Priest was required to be of twenty-four years of age, which is confirmed by the XXXIV. Canon of 1603, and by the present rubric: and the Canonical age for the Diaconate is fixed at twenty-three years, unless he have a faculty, that is, a licence, or dispensation from the Archbishop of Canterbury, given to persons of extraordinary abilities, by virtue of the Act 44 George III. c. xliii. c. 1, which confirmed the right hitherto held by the Primates [21 Hen. VIII. c. xxi. § 3]. Martene furnishes several instances of ordination before the canonical age [de Ant. Rit. Eccl. l. i. c. viii. Art. iii. § 4]. Archbishops Sharp and Ussher, and Bishops Bull and Jeremy Taylor, and Ven. Bede were all ordained Priests before the age of twenty-four years. And the monks of Westminster had the privilege of ordination to the Priesthood at twenty-one years of age.

The Deacon must continue in the office of a Deacon the space of a whole year ["at the least," 1552], except for reasonable causes if shall otherwise seem good unto the Bishop [his ordinary, 1552], to the intent he may be perfect and well expert in the things appertaining to ecclesiastical administration. An interval has always been required between ordination to the Diaconate and to the Priesthood [St. Greg. Naz., Orat. xxi. § 7; St. Hier., Ep. xxxv. ad Heliod.; St. Cyprian, Ep. lv. p. 108; Leo, Ep. lxxxv. c. i.; Decret. P. i. dist. lxxviii. c. iii.]. The Councils of Barcelona, 599, c. iii.; Dalmatia, 1199, c. ii.; Bourdeaux, 1024, c. vi. n. iii., and Trent, Sess. xxiii. 1563, c. xiv., prescribe one year's service in the Diaconate; Zosimus [Ep. i. c. ii.], and Siricius [Ep. i. c. ix.], and Canon Law [Decr. i. dist. lxxvii. c. ii. iii.], five years; and the Council of Constantinople [870, Act. x. c. v. xvii.], and Hormisdas [Ep. xxv. c. i.] three years, and for the Priesthood, four years. By the old English

Pontifical: "Inhibemus quod nullus Ordinem recipiat Diaconatus nisi fuerit ætatis viginti annorum, Presbyteratus viginti quatuor, et vicesimum quintum attigerit." [Lacy's Pontifical, p. 78.]

III. By the XXXI. Canon, the place of ordination is defined to be the Cathedral or the Parish Church where the Bishop resideth, "and the ordination is to take place in presence of the Archdeacon, the Dean, and the two Prebendaries, at the least, or four grave persons, being M.A. at the least, and allowed to be preachers." The ordination is to take place "in the face of the Church;" and the Church is best represented by the Cathedral of the Diocesan who ordains. Bishops were absolutely interdicted from holding ordinations, except within their own dioceses, by the Apost. Can. c. xxxv.; I. Council of Nicæa, c. xv.; I. Constantinople, c. ii.; Antioch, c. xiii. xxii.; I. Tours, 461, c. ix.; III. Orleans, 538, c. xv., and Aix, 789, c. xi. As early as 1538, the X. Article says: "Docemus quod nullus ad ecclesie Ministerium vocatus, etiamsi Episcopus sit, hoc sibi jure divino vindicare possit, ut ullam Ecclesiasticam functionem in alienâ diocesi exercere valeat, hoc est nec Episcopus in alterius diocesi, etc." [§ xiii.] The Bishop at ordination is seated in a chair near the Holy Table, as the Candidates, according to Simeon of Thessalonica and Dionysius and Theodoret, were also ordained in the Sanctuary [Hist. Eccles. p. 166; Morin, P. ii. p. 47. 106], and the Greek Euchologium has a similar rubric, "The High Priest sitteth in front of the Holy Table on a little throne" [Goar, p. 292]. Amalarius also mentions that the Deacons and Priests received ordination before the Altar [de Div. Off. l. ii. c. vi.]. The Councils of Rouen, 1581, and Bourdeaux, 1624, require the ordinations to be made at the High Altar, and the IV. Council of Milan, that they should be held in the principal church of a town, if not in the cathedral, in both places reinforcing the decree of the Council of Trent [Sess. xxiii. c. viii.].

IV. The appointment of times for ordination is the public demand of the Church in the name of the Lord Himself, "Whom shall I send, and who shall go for Us?" [Isa. vi. 8.] There are besides the vocation and voluntary offer of the Candidate, two solemn preliminaries, examination by the Bishop and Clergy [Theophilus of Alexandria in Can. vi. Apost. Const. lii. c. 28, l. viii. c. 16. St. Cyprian, Ep. xxxviii. lxxvii. Posidonius in Vit. Aug. c. xxi. IV. Council of Carthage, 398, c. xxii.], and the testimony of the people. The former is enforced by St. Paul himself; by St. Chrysostom de Sacerd. liv. c. ii.; St. Cyprian ad Cler., Ep. xxix.; by Gregory I. ad Adeod., Ep. xlix. l. iii.; Siricius, Ep. iii. c. i.; the Canon Law, Decret. P. i. dist. lxxxii. c. iv.; Theophilus Alex., Comm. in Can. vi.; Theophylact in I Tim. c. v., and these Councils—Nicæa, c. ix.; Aix, 789, c. ii.; Besiers, 1233, c. vi.; Lateran, 1215, c. xxvii.; VIII. Toledo, 653, c. viii.; Canon Arabici, 325, c. xii. The English Church has always observed the same rule. [Councils of Cloveshoe, 747, c. vi. Cealchythe, 787, c. vi. Oxford, 1222, de Ordin., and 1322; Lambeth, 1330, c. vi.; Lyndewood, Prov. l. i. tit. v. vi., and App. p. 17, and Council of London, 1557, tit. de qual. ordin.] For this cause, and to prevent uncanonical intrusions, Bishops were forbidden to ordain clerks out of their own diocese; unless with the consent and letters of the Diocesan. [Councils of London, 1175, c. v.; III. Orleans, 538, c. vi.; Sardica, 347, c. xv.; III. Carthage, 397, c. xxi.; IV. Carthage, 398, c. xxvii.; II. Braga, 563, c. viii.; Mayence, 888, c. xiv.; Rouen, 1050, c. ix.; Lucca, 1308, c. xvi.; Rheims, 1564, c. viii. ix.; Cambray, 1565, c. x.; Bourges, 1584, c. iii.; and Trent, Sess. xxiii., 1563, de Reform. c. vii.] Nor may one Bishop ordain the Clerk of another without Letters dismissory from the latter granting his permission and sanction [XXXIV. Canon, 1603, Lyndew. Prov. l. i. tit. iv. pp. 27. 32. Cardw. Doc. Ann. ii. 322. 356. 420].

Wednesday appears to have been the usual day for the commencement of the examination, and three days are sometimes prescribed for it [Council of Nantes, c. xi.; Decret. P. i. dist. xxiv. c. v.]. Three points are insisted upon in the Canon Law—canonical age, sufficient knowledge, and virtuous conversation. The Bishop himself has the chief position in the examination, then the Archdeacon, the Dean and two Prebendaries of the Cathedral Church [Canon xxxi. xxxv. 1603], and his own Chaplains, of

whom, by the Act of 25 Henry VIII., he is permitted to have two additional, and the Archbishop four, to assist him in ordination. "Grave and expert men" are required to aid him in this work by Gregory I. [Ep. xlix. l. iii. ind. xi.]. The Council of Nantes, 900, c. xi., appoints Priests attached to his person, and other prudent men, well skilled in the Divine law, and instructed in Ecclesiastical rule. Three examiners at least are appointed by the Council of Toledo, 1473, c. xi., and by others of later date three; in allusion, doubtless, to the Scriptural rule [Deut. xix. 15]. The English rule, says Bp. Stillingfleet in 1681, was to have four.

The examiners are to require virtuous conversation and sufficient knowledge of Latin and the Holy Scriptures. The old rubrics ran thus:—

"*Nullus ordinetur nisi examinatio precedat.*" [Lacy's Pontifical, p. 75.] "*Postea stant inhibitiones in generalibus ordinibus et Episcopo placuerit. In virtute Spiritus Sancti inhibemus sub poena anathematis ne quis se ingerat ordinandum nisi prius examinata persona, cum titulo intitulatus fuerit et vocatus. Nequis etiam mortalis peccati conscius vel excommunicatus aut suspensus ordines recipiat. Item nullus alterius diocesis, nisi literas dimissorias habuerit.*" [Lacy's Pontifical, p. 77.]

The Canon Law required that diligent inquiry should be made into the life, age, title, and place of education of the Candidate; whether he was well learned, instructed in the law of the Lord, and, above all, if he firmly held the Catholic faith, and could express it in simple words [Decret. P. i. dist. xxiv. c. v.]. But besides these requirements, a long list of canonical impediments, such as irregularity, i. e. bodily deformity, illegitimacy, and the like, offered hindrance to the reception of a Candidate. But all the Canons of the Church require him to be without crime [Prov. Lyndev. lib. i. tit. iv. v. vi., App. 16, 17; Conc. of Chichester, 1246; Exeter, 1287, c. viii.; IV. Carthage, 398, c. lxvii. lxviii.; Epaon, 517, c. iii.; III. Orleans, 538, c. vi.; Agde, c. xliii.; Nicæa, c. x.; IV. Toledo, 663, c. xix.; Canon. Apost. c. xviii.]. St. Cyprian says, that in accordance with the Divine law [Exod. xxi. 21; xix. 22; xxviii. 43], Priests and Deacons should be morally whole and without blemish [Ep. lxxii. Stephano], and, as St. Augustine well says, St. Paul, when he chose Priests and Deacons, saith not, "If any be without sin;" for had he said this, every man would be rejected, none would be ordained, but he saith, "If any be without crime, such as murder, adultery, any uncleanness, fornication, theft, cheatery, sacrilege, and the like." [Tract. xli. in St. Joann. c. viii.] The knowledge of letters is required by the I. Council of Rome, 465, c. ii.; Luca, 1308, c. xxxiv.; II. Orleans, c. xvi.; and Canon Law Decr. P. i. dist. xxxvi. c. i. ix. x. xiv.; and Novell. Just. cxliii. tit. xv. c. xii.; and of Latin by the Councils of Genoa, 1274, c. 25, and Toledo, 1473, c. iii., and London, 1571, c. i. St. Paul required a man to be apt to teach, and to be distinguished from the unlearned [1 Cor. xiv. 16]. Knowledge of the Holy Scriptures is insisted upon by St. Jerome [Comm. in Agg. c. ii.], Councils of Nantes, 900, c. xi.; IV. Toledo, 663, c. xxv.; and Canterbury, 1525; while at the present time, knowledge of Greek is considered indispensable in Candidates, and Hebrew is sometimes required.

The concurrence of the people, or rather their testimony, is required, as the Levitical Priests were presented to the congregation [Exod. xxix. 4]; and seven men "of good report" were the first Deacons [Acts vi. 3]. In the Primitive Church, a proclamation of the Candidates, an *ἐπικήρυξις*, or *prædicatio*, was always used [Lampridius, c. xlv. Council of Chalcedon, A.D. 451]. A "Si quis" is now read out in the parish Church of the Candidate before ordination, and letters testimonial from his College, or three beneficed Clergymen, are necessary. An appeal is also made to the congregation, whether they know any notable crime, or canonical impediment, in accordance with the rule of the Old English Church [Excerpt. Egberti, c. xcix.]. In the early Church, the people gave their approbation, or consent, or expressed their rejection of the unworthy by exclaiming "Αἴτιος, or ἀνάξιτος" [Const. Apost. l. viii. c. iv.; St. Ambros. de Dign. Sacerd. c. v.; Euseb. H. E. lib. vi. c. xxix. xliii.]. There was no election by the people, except in the case of the seven Deacons (and of these because made stewards of the common stock of the Church), and when

Deacons were appointed to Ministerial offices, the people's voice had no share in the matter of choice, but reference was made to them, as by St. Peter at the consecration of St. Matthias. Yet whilst Bishops reserved to themselves the absolute and inherent right of acceptance or rejection [Decret. P. i. dist. lxiii. c. viii.; Posid. in Vit. Aug. c. iv.], they wisely, when the gift of discerning of spirits was withdrawn, asked for the testimony of the Clergy and people (not the people only), amongst whom the Candidate had lived, to his virtuous conversation [St. Cypr., Ep. xxxviii.; St. Jerome, Ep. xcv. ad Rust.; Siricius, Epist. i. c. x.; Leo, 1. Ep. lxxxix. § 3; III. Council Carthage, 397, c. xxii.; IV. Carthage, 398, c. xxii.; and the ancient Sacramentaries and Pontificals]. If any crime was then objected [Apost. Can. c. lxi.] the ordination was deferred, and the accuser examined strictly within three months. If he failed to offer sufficient proof, if a clerk, he was degraded, and if a layman, adequately punished [Novell. Just. Const. cxxxvii. p. 408]. But the ordainer was not to take the accusation without proof [Conc. Chal. c. xxi.], and no excommunicate person, or one not a communicant, was allowed to be heard [Conc. Constant. c. vi.]. Damasus, in 367, required the accuser to put in a caution that in default ample atonement to the sufferer might be made by him [Epist. iv. c. vii.], and the Canon Law forbade the delivery of the Holy Communion to a false accuser from that day forth [Decret. P. ii. Caus. ii. qu. iii. c. iv.]. In all rituals the congregation are desired to unite in prayer for the Candidates.

V. Our blessed Lord as the Chief Bishop and Great High Priest chose and ordained [St. John xv. 16] the Apostles and the Seventy Disciples, the first Bishops and Priests of His Church. After His Ascension, St. Matthias was elected by God [Prov. xvi. 33], and the Twelve were endowed with the miraculous power of discerning spirits, knowing men's hearts, whether they were sincere and spiritually minded [1 Cor. xii. 10], by prophecy, that is, by the Holy Ghost, says Theophylact [in 1 Tim. i. 18], and St. Chrysostom [Hom. v. in 1 Tim. i.], by ordinance of the Spirit, according to Ecumenius [in 1 Ep. ad Tim. iv.], by Divine revelation, as Theodoret explains [in 1 Tim. i.], or as Clement of Alexandria asserts of St. John, that he ordained Bishops and Clergy out of such as were signified by the Spirit [Euseb. iii. 23]. But as this heavenly gift died with the Apostles, St. Paul laid down rules for the fitness of Candidates to St. Timothy and Titus, and as St. Clement says, "The Apostles knew from our Lord Jesus Christ that there would be a strife touching the name of Bishops. For this cause, having a perfect foreknowledge, they established Bishops and Deacons, and a rule of future succession, that after their decease others approved [by the Holy Ghost] might receive their ministry" [ad Corinth. § xlv.]. This succession is that of Bishops.

The Jewish Priesthood was hereditary, adapted to the circumstances of a temporal dispensation, and a people forbidden communication with other nations. But the Church has a spiritual ministry, is one and Catholic, designed to bring all countries into the one fold, under one Shepherd, and to last even unto the end of the world. The Chief Bishop was born of the royal tribe, not of that of Levi, a Priest after the order of Melchisedec, not of Aaron. Therefore her "succession is not limited to a lineage, or her ministries assigned to a single family, but from every tribe, and people, and language, those whom Divine choice approves as fit and worthy, she constitutes Priests, not on the merits of birth, but of worth" [St. Cypr. de Unct. Christm.]. The best of every nation she presses into her service [Const. Apost. l. vi. c. xxxiii.]. Simony, heresy, schism, or any other grievous sin, will not hinder the effect of the laying on of the hands of the Ordainer [Art. xxvi. Glossa Decret. P. ii., c. i. qu. 1, c. xvii.], just as under the Law bodily blemishes did debar the Priest from offering the "Bread of God" [Lev. xxi. 17], yet did not cut off the entail, interrupt the succession, or disentitle his sons from the inheritance of the Priesthood. Moses, appointed by extraordinary commission from God, consecrated Aaron as High Priest, and Aaron's sons as Priests [Ps. xcix. 6. Exod. xxix. 30. Lev. viii.]. Aaron continued the succession [Heb. v. 4. Numb. viii. 11. 13]. When the Apostles received the gift of the Priesthood [1 Pet. ii. 25. Luke xxii. 29.

John xx. 22], they by Divine appointment divided the Ministry into such degrees and orders as were necessary to the government and comeliness of the Church. They, having consecrated Bishops [1 Tim. iv. 14. 2 Tim. i. 6. Tit. i. 45], either ordained Priests [Acts xiv. 23], or desired Bishops to ordain such, reserving the plenitude of power, which is the peculiar and special endowment of the Episcopate; and also ordained Deacons [Acts vi. 6]. It must be observed that there are only two exceptional instances, those of St. Paul and St. Barnabas, ordained by teachers and prophets [Acts xiii. 1]; but the one was miraculously called to be an Apostle [Gal. i. 12. 15. 17], and the other was sent out by the collective Church [Acts xi. 22. 30; xii. 25], and the Consecration is expressly referred to an extraordinary act by the Holy Ghost [Acts xiii. 2].

The great charter, bestowing the exclusive power of Ordination upon Bishops, lay in the words of the Redeemer to the Apostles, "As My Father hath sent Me, even so send I you;" as Bishops are the successors of the Apostles, so the Church has always kept this rule without break or doubtfulness. In the Eastern Church, the essential power of Ordination has always been reserved to Bishops exclusively, and it was not until the fourth century that the African Church permitted Priests to lay on their hands with the Bishops in the Ordination of Priests: nor after this rule was adopted by the Western Church, is there any example in ecclesiastical history of ordination by any but Bishops only, as their proper and peculiar function confirmed by the ancient Apostolical Canons and Constitutions, by the Councils of Ancyra, Antioch, c. ix., Sardica, c. xix., Alexandria, Nicæa, c. xix., Chalcedon, c. xi., VI. Trullo, c. xxxvii., Constantinople, Orange, II. Orleans, c. iii., Braga, c. iii., Cealchythe, c. vi., Dalmatia, c. ii., and Seville, c. vi.; by the testimonies of the fathers, St. Athanasius [II. Apol. c. Athan.], St. Chrysostom [in Phil. hom. i., in 1 Tim. iii.], St. Augustine [de Hær. c. lii.], St. Epiphanius, St. Jerome [Epist. ad Evang. ci.], St. Cyprian [Ep. xli.], Cornelius, Dionysius; by the acts of primitive Bishops, and by every sacramentary and ritual [Decret. P. i., dist. lxxvii.]. On the other hand, Ordinations by Priests only were constantly declared to be null and void, and to communicate Presbyterian Ordination was affirmed to be heresy by the united voice of Christendom; and, as Bp. Hall says, "that Presbyter would have been a monster among Christians, that should have dared to usurp it." The Catholic doctrine has ever been that without Sacraments there is no Church, and without Bishops there can be no Priests, and consequently no Sacraments. There is not one instance in Holy Scripture or ecclesiastical history, of Ordination by Presbyters only; it was the prerogative of Bishops, and therefore the present rubric (1662) declares that "no man shall be accounted or taken to be a lawful Bishop, Priest, or Deacon, or suffered to execute any of the said functions, except he be called, tried, examined, and admitted thereunto, according to the Form hereafter following, or hath had formerly Episcopal consecration or ordination." Priests of the Western and Eastern Church, on conforming to her discipline and doctrine, are therefore admitted at once to minister in the churches of England; and in the Office of Consecration of Bishops, in 1662, the question was significantly added: "*Archbishop*: Will you be faithful in ordaining, sending, or laying hands on others? *Answer*: I will so be, by the help of God." The special powers of the Bishop lie in the right to ordain, to consecrate persons and things, to administer Confirmation, and in jurisdiction; just as the Diaconate does not possess the privilege of the Priesthood, to consecrate the Holy Eucharist, to absolve, to preach, and ordinarily, to baptize.

The Priesthood, however, have an important part in Ordination of Priests and Deacons, for their testimony is required before the acceptance of a candidate, their aid in his examination, and their presence at the laying on of hands. Where the laying on of the hands of the Presbytery is mentioned by St. Paul [1 Tim. iv. 14], the Presbytery (a word sometimes used in the sense of an order) has been understood by St. Chrysostom, Theodoret, Ecumenius, Theophylact, Suicer, and all the best commentators, ancient and modern, to designate the College of Bishops; and this gift which is said to have been given by the laying on of their hands, is in the Second Epistle [c. i. 6] said to have been given by the laying

on of the Apostles' hands, so that the utmost that could be made of the passage, even in conjunction with the Carthaginian Canon, would be, that Priests sometimes imposed their hands, together with an Apostle or Bishop. But St. Timothy was a Bishop [1 Tim. v. 22], and nowhere have we an example of Priests ordaining a Bishop; and the Council of Carthage, reserving the ordination of Deacons to the Bishop solely, only required the presence of the Priests (who were enjoined to be silent), in order to add solemnity to the Ordination, and to preclude the admission of unworthy or unfitting persons to the Priesthood. Even this canon was not in harmony with ancient practice, although it rightly permitted the Bishop alone to bless the person ordained. A remarkable use of prepositions in the passage of the Epistle to Timothy just cited, must also be noted. In the case of St. Paul it is *δὰ*, through, by means of, laying on of my hands, but in the case of "the Presbytery," *μετὰ*, together with: one was instrumental, the other assistant.

The Ephesian Presbytery after all were the "elders of the Church" of Ephesus, whom St. Paul says "the Holy Ghost had made Bishops over the flocks" [Acts xx. 17. 28]. The third Council of Carthage, held only one year before that which permitted Priests to assist, laid down this canon [c. xlv.]: "Episcopus unus esse potest per quem dignatione Divinâ Presbyteri multi constitui possunt;" and, to avoid any doubt, the Epistle, 1 Tim. iii., was transferred from the Ordering of Priests to the Consecration of Bishops, in 1662. The Catholic Church has ever held this doctrine, that true ministrations of grace depend on Episcopal ministries, and has always regarded all other ministries, whether assumed to be conferred by Presbyters, undertaken at will, or bestowed by a call from the congregation, to be wholly invalid. Luther, Knox, and Wesley were but Priests, Whitfield a Deacon, Calvin a Subdeacon, and others mere laymen; every mission by their hands is therefore absolutely null and void, according to Scriptural authority, Apostolical practice, and the unbroken tradition of eighteen centuries. Those only who have Episcopal orders of Bishop, Priest, or Deacon, in the Western and Eastern Churches (including also now that of America), according to the XXIII. and XXVI. Articles of our Church, minister the Word of God, and His Sacraments, in Christ's name, and by His commission and authority. All others must be actually *ordained*, whether of previous Presbyterian or congregational nomination, on conforming to the Church; as in 1661, four teachers of the former in Scotland were first ordained Deacons and Priests, and then, on Dec. 15, Bishops of the Scottish Church [Wood A. O. Fasti iv. 321]. A Roman or Greek Subdeacon is regarded as a layman. In some cases of, the Superior or Major orders an imposition of hands "*non-ordinativa sed reconciliatoria*" has been used. One of the earliest declarations from authority after the Reformation, against orders conveyed by Presbyters, of the year 1585, may be seen in Cardwell, Doc. Ann. No. cii.

As the chief magistrate is the fountain of honour in the State, so in the Church the Bishop is the chief in the Christian polity, a prince in the spiritual commonwealth, with the sole power of Ordination, and distribution of grades and offices, and degrees of ministry; and the reservation of this power to the Episcopate is a visible symbol of the unity of the One Catholic and Apostolic Church. There is but one Spirit of grace, though there are diversities of gifts and operations. In 1549, the necessity of lawful admission by the Bishop was asserted in the Preface to the Ordinal, and this lawful admission, in the X. Article of 1538, is reproduced in the XXIII. of 1562 ("Non licet," it is not lawful by God's law, &c.), and is clearly expressed, "Docemus quod nemo debeat publice docere aut Sacramenta ministrare nisi rite vocatus et quidem ab his penes quos in Ecclesia juxta verbum Dei et leges et consuetudines uniuscujusque regionis jus est vocandi et admittendi." [§ xiii.] Therefore in the Litany she prays for the whole Catholic Church, for *all* Bishops, Priests, and Deacons; for *all* Bishops, Pastors, and Curates, in her Collect for St. Peter's Day, and her prayer for the Church militant; and in the first prayer for Ember Week supplications are offered without any limitation for the Bishops and Pastors of God's flock, all of one fold under one Shepherd.

THE FORM AND MANNER
OF
MAKING, ORDAINING, AND CONSECRATING
OF
BISHOPS, PRIESTS, AND DEACONS,
ACCORDING TO THE
Order of the Church of England.

Salisbury Use.
CELEBRATIO
ORDINUM.

THE PREFACE.

IT is evident unto all men diligently reading the holy Scripture and ancient Authors, that from the Apostles' time there have been these Orders of Ministers in Christ's Church; Bishops, Priests, and Deacons. Which Offices were evermore had in such reverend Estimation, that no man might presume to execute any of them, except he were first called, tried, examined, and known to have such qualities as are requisite for the same; and also by publick Prayer, with Imposition of Hands, were approved and admitted thereunto by lawful Authority. And therefore, to the intent that these Orders may be continued, and reverently used and esteemed in the Church of England; no man shall be accounted or taken to be a lawful Bishop, Priest, or Deacon in the Church of England, or suffered to execute any of the said Functions, except he be called, tried, examined, and admitted thereunto, according to the Form hereafter following, or hath had formerly Episcopal Consecration, or Ordination.

THE PREFACE.

Church of England] This is misprinted in some modern Prayer Books, "the United Church of England and Ireland." The above is the only legal form, and the reasons why it is desirable to retain that form are stated at page 2].

It is evident unto all men] For notes on this subject consult the preceding Introduction.

Twenty-three years of age] The excerpts of Archbishop Ecgbert, quoting a Carthaginian Canon, decree: "Placuit ut ante xxv annos ætatis, nec diaconus ordinetur, nec virgines consecrarent, nisi rationabili necessitate cogente." The Pupilla Oculi [Lib. vii. cap. 4, A.], "Ordinandus in exorcistam, lectorem, seu ostiarium debet esse major infante, i.e. major septennio. Et similiter ille qui primam tonsuram suscipit ordinandus in acolytum debet esse major xiiij annis. Item major xvij annis potest ordinari in subdiaconum. Major etiam xix annis potest ordinari in diaconum: et major xxiv annis in sacerdotem: et major xxx annis potest esse Episcopus." [Maskell, Mon. Rit. iii. cvii.]

times appointed in the Canon] In 1661, on April 21, the Committee for the revision of the Ordinal resolved, "quod nullæ ordinationes clericorum per aliquos Episcopos fierent nisi intra quatuor tempora pro ordinationibus assignata." [Cardw. Synod. ii. 670.] These are the Ember Days, the Ymbren Dagas (from ymb, round, and ren, to run) [per totius anni circulum distributi. St. Leo, Sermon. viii. de Jej. X. mens. Op. tom. i. col. 59] of the Anglo-Saxon Church, occurring in regular circuit and course, the *Jejunia Quatuor Temporum*, corrupted into *Quatember* in German,

and Ember in English, the Fasts of the Four Seasons on which the year revolves. They are the Wednesday, Friday, and Saturday after the 1st Sunday in Lent, after Whitsunday, after Sept. 14, Holy Cross, and after Dec. 13, St. Lucy.

Gelasius, probably, was the first who limited the seasons of general ordination to certain times of the year. Micrologus says, "Gelasius papa constituit, ut ordinationes presbyterorum, et diaconorum non nisi certis temporibus fierent." [Cap. 24, p. 448, edit. Hittorp.] So also Rabanus Maurus: "Sacras ordinationes quatuor temporum diebus oportere fieri, decreta Gelasii papæ testantur." [De Instit. Cleric. lib. 2, cap. 24, p. 338, Ibid.] Maskell, Mon. Rit. iii. cxxii. Muratori is of opinion that no fixed and general rule for the observance of Ember weeks existed until the Pontificate of Gregory VII. c. 1085. [Diss. de Jej. IV. temp. c. vii. Anecd. tom. ii. p. 262.]

Our Canons of 1604 enjoin as follows:—

CANON 34.

The Quality of such as are to be made Ministers.

No Bishop shall henceforth admit any person into Sacred Orders, which is not of his own diocese, except he be either of one of the Universities of this realm, or except he shall bring Letters Dimissory (so termed) from the Bishop of whose diocese he is; and desiring to be a Deacon, is three and twenty years old; and to be a Priest, four and twenty years complete; and hath taken some degree of school in either of the said Universities; or at the least, except he be able to yield an account of his faith in Latin, according to the Articles of Religion approved

And none shall be admitted a Deacon, except he be Twenty-three years of age, unless he have a Faculty. And every man which is to be admitted a Priest shall be full Four-and-twenty years old. And every man which is to be ordained or consecrated Bishop shall be fully Thirty years of age.

And the Bishop knowing either by himself, or by sufficient testimony, any person to be a man of virtuous conversation, and without crime, and, after examination and trial, finding him learned in the Latin Tongue, and sufficiently instructed in holy Scripture, may at the times appointed in the Canon, or else, on urgent occasion, upon some other Sunday or Holy-day, in the face of the Church, admit him a Deacon, in such manner and form as hereafter followeth.

THE FORM AND MANNER

OF

MAKING OF DEACONS.

¶ *When the day appointed by the Bishop is come, after Morning Prayer is ended, there shall be a Sermon or Exhortation, declaring the Duty and Office of such as come to be admitted Deacons; how necessary that Order is in the Church of Christ, and also, how the people ought to esteem them in their Office.*

¶ *First the Arch-Deacon, or his Deputy, shall*

¶ *Quando ordines agantur, primo fiat sermo si Salisbury Use, placeat Dum officium canitur, vocentur: nominatim illi qui ordinandi sunt*

¶ *Deinde sedeat episcopus ante altare conver-*

in the Synod of the Bishops and Clergy of this realm, one thousand five hundred sixty and two, and to confirm the same by sufficient testimonies out of the holy Scriptures; and except moreover he shall then exhibit Letters Testimonial of his good life and conversation, under the seal of some College in Cambridge or Oxford, where before he remained, or of three or four grave Ministers, together with the subscription and testimony of other credible persons, who have known his life and behaviour by the space of three years next before.

ORDINATION OF DEACONS.

Sermon or Exhortation] An Exhortation to the Deacons after the presentation will be found in Assemanni viii. 377, from the Pontifical of Clement VIII., and one to the Priests after the address to the people [Ib. 363]. By the Sarum and Exeter Pontifical, after the Introductory Sermon the Bishop read out the Prohibitions or Canonical Impediments. In the Winchester Pontifical, the sermon by the Bishop follows the presentation of the Deacons by the Archdeacon. The rubric directs that it shall treat "de castitate, de abstinentia, et his similibus virtutibus: terribiliter interdicens ne quis ad sacros ordines venire præsumat qui pecuniam dare promittere præsumperit." [Mask. Mon. Rit. iii. 155.]

the Arch-Deacon] Next to the Bishop himself, his vicar the Archdeacon is charged with the duty of examining candidates for ordination, and is to declare that "he has inquired of them and also examined them." [Comp. Catalani Pont. Rom. tom. i. § xvi. p. 51, Rome, 1739. Martene de Antiq. Rit. tom. ii. col. 39, B.C. Antv. 1736. Council of Coyaco, A.D. 1050, c. 5. Labbe, tom. xi. col. 1441, E.] This is in conformity with the Council of Carthage and the Canon Law as early as the ninth century.

"Nos meminimus expressisse quod ad Archidiaconum debeat pertinere examinatio etiam clericorum si fuerint ad Sacros Ordines promovendi." [Decret. Greg. lib. i. tit. xxiv. cap. vii.] "Ea de jure communi ad Archidiaconi spectent officium, scilicet representare ordinandos Episcopo et illos examinare." [Ib. cap. ix. Corp. Jur. Can. tom. ii. col. 315. 48. 316. 44.] "De jure civili hæc examinatio pertinet ad Archidiaconum; ad hæc alias, si sit absens Episcopus, potest per se examinare, si velit, vel aliis idoneis circa latus suum id committere." [Lyndewood, Prov. Anglic. lib. i. tit. v. vi., Oxf. 1679, p. 33. Comp. Bingham, Orig. Eccles. b. ii. c. xxi. sect. 7, vol. i. p. 94, ed. 1724; and Morin de Sac. Ord. pt. iii. c. iii. § 3, p. 218, D.] By the 4th Council of Carthage, A.D. 398, c. 5, 6, 7 [Labbe, ii. col. 1437-8], the Archdeacon was to give the vessels used by his order to the Deacon. By the Capitulars of Hincmar, A.D. 877, c. xi., the Archdeacons receive this injunction: "Sollicite providete de vita et scientia clericorum quos ad ordinationem adducetis, ne pro aliquo munere tales ad ordinandum introducatis qui introduci non debent." [Op. Hincmar. tom. i. p. 740, Lutet. 1645.] About the beginning of the eleventh century, the Archdeacon in the Greek Church bore a prominent part at ordinations [Euchologium; Morin de Sac. Ord. pt. ii. p. 63, Antv. 1695], and two centuries after this rubric occurs, *μελλων χειροτονεισθαι εις την διακονιαν προσάγεται ενδ τοῦ ἀρχidiaκόνου.* [Ib. p. 69.] In the Syro-Nestorian Ordinal as translated by Morin: "Stat præsul super sedem et qui ordinandi sunt subtus candelabrum ubi adorant; tum dicit Archidiaconus, Oremus" [P. ii. p. 373], and in the Coptic Ordinal: "Postquam præsentator Diaconi ex sacerdotibus intellexit eum hoc Ministro dignum esse, præsentabunt eum Episcopo testificantes de eo. Stabit autem præsentatus ante altare coram Episcopo." [P. ii. p. 444, C.]

or his Deputy] In the Ordering of Priests, "or, in his

present unto the Bishop (sitting in his chair, near to the holy Table) such as desire to be ordained Deacons, (each of them being decently habited,) saying these words,

Exod. xxviii. 4, 2.
1 Cor. iv. 15.
Matt. ix. 37, 38.
Acts vi. 1—6.

REVEREND Father in God, I present unto you these persons present, to be admitted Deacons.

The Bishop.

Numb. viii. 5, 6.
1—14.
1 Tim. v. 22.
iii. 8, 9.
2 Tim. ii. 24, 25.

TAKE heed that the persons, whom ye present unto us, be apt and meet, for their learning and godly conversation, to exercise their Ministry duly, to the honour of God, and the edifying of his Church.

¶ *The Arch-Deacon shall answer,*

Acts vi. 3.
1 John iv. 1.

I HAVE enquired of them, and also examined them, and think them so to be.

¶ *Then the Bishop shall say unto the people :*

1 Tim. iii. 7.
Acts xxiv. 16.

BRETHREN, if there be any of you who knoweth any Impediment, or notable Crime, in any of these persons presented to be ordered Deacons, for the which he ought not to be admitted to that Office, let him come forth in the Name of God, and shew what the Crime or Impediment is.

sus ad ordinandos, et archidiaconus capa Salisbury Use. indutus humiliter respiciens in episcopum cum his verbis alloquatur, ita dicens. . . .

POSTULAT hæc sancta Ecclesia, reverende pater, hos viros ordinibus aptos consecrari sibi a vestra paternitate.

Resp. Episcopi: Vide ut natura, scientia, et moribus, tales per te introducantur, immo tales per nos in domo Domini ordinentur personæ, per quas Diabolus procul pellatur, et clerus Deo nostro multiplicetur.

Resp. Archidiaconi: Quantum ad humanum spectat, examen, natura, scientia et moribus digni habentur, ut probi cooperatores effici in his, Deo volente, possint.

¶ *Quibus expletis, dicat episcopus hanc orationem publice, stando, sine nota.*

AUXILIANTE Domino et Salvatore nostro Jesu Christo, præsentibus fratres nostri in sacrum ordinem electi sunt a nobis, et clericis huic sanctæ sedi famulantibus. Alii ad officium presbyterii, diaconii, vel subdiaconii, quidam vero ad cæteros ecclesiasticos gradus. Proinde admonemus et postulamus, tam vos clericos quam cæterum populum, ut pro nobis et pro illis puro corde et sincera mente apud divinam clementiam intercedere dignemini, quatenus nos dignos faciat pro illis exaudiri: et eos unumquemque in suo ordine eligere, et consecrare per manus nostras dignetur. Si quis autem habet aliquid contra hos viros, pro Deo et propter Deum, cum fiducia exeat et dicat, verumtamen memor sit communionis suæ.

* * * * *

absence one appointed in his stead." That is, one of the examiners of the Candidate, "alter clericus cui Episcopus faciendum injunxerit" [Pont. Mogunt. ann. circa cccc. Ord. xvi.; Martene de Ant. Rit. ii. col. 214], and so by English Canon Law: "In die ordinum celebrandorum Archidiaconus vel Examinator alius ad hoc deputatus, in actu celebrationis ordinum presentabit Episcopo ordinanti ipsos ordinandos." [Provinc. lib. i. tit. v. vi. p. 33.]

decently habited] In the old rubric of 1549, they were desired to appear in an albe, but it must be remembered that then the Candidate was a Subdeacon, not, as now, a layman. The

present rubric requires, if not an albe, at least a surplice, as the fitting dress of the Candidate for the Order of Deacon.

Reverend Father in God] Bishops are called Fathers by Epiphanius [Hær. l. iii. § lxxv. c. iv.], not of the universal Church, which God alone is, but in particular branches thereof. The title is founded on 1 Cor. iv. 15. 2 Cor. vi. 13. Gal. iv. 19. 1 John ii. 1. 13, 14. The word Papa was similarly used by St. Jerome [Ep. xciv.], and in the fifth and sixth centuries [Sidonius, lib. vi. Ep. 1—12; vii. Ep. 1—11]. According to Baronius, in 1076, it was restricted to the Bishop of Rome.

I present unto you] The ancient form of presentation was

¶ *And if any great Crime or Impediment be objected, the Bishop shall surcease from Ordering that person, until such time as the party accused shall be found clear of that Crime.*

¶ *Then the Bishop (commending such as shall be found meet to be Ordered to the Prayers of the congregation) shall, with the Clergy and people present, sing or say the Litany, with the Prayers as followeth.*

1 Thess. v. 25.

The Litany and Suffrages.

O GOD the Father, of heaven : have mercy upon us miserable sinners.

O God the Father, of heaven : have mercy upon us miserable sinners.

* * * * *

That it may please thee to illuminate all Bishops, Priests, and Deacons, with true knowledge and understanding of thy Word; and that both by their preaching and living they may set it forth, and shew it accordingly;

We beseech thee to hear us, good Lord.

That it may please thee to bless these thy servants, now to be admitted to the Order of Deacons, [*or Priests,*] and to pour thy grace upon them; that they may duly execute their Office, to the edifying of thy Church, and the glory of thy holy Name.

* * * * *

Let us pray.

WE humbly beseech thee, O Father, mercifully to look upon our infirmities; and for the glory of thy Name turn from us all those evils

¶ *Deinde accedentes qui ordinandi sunt diaconi et sacerdotes cum vestibus suis, et prostrato episcopo ante altare cum sacerdotibus et levitis ordinandis, postea duo clerici incipient litaniam . . .*

For originals, &c. of Litany, see pp. 46-61.

Ut Apostolicum donum, et omnes gradus ecclesie, in sancta religione conservare digneris, Te rogamus.

¶ *Hic surgat episcopus et sumat baculum in manu sua, et conversus ad ordinandos dicat.*

Ut electos istos benedixere digneris,

Te rogamus.

Ut electos istos benedixere et sanctificare digneris,

Te rogamus.

Ut electos istos benedixere, sanctificare et consecrare digneris,

Te rogamus.

Ps. xxviii. 9.
Numb. viii. 14-16.
Heb. xlii. 9.
1 Pet. iv. 10.
Eph. iv. 17, 12.
Phil. i. 11.

“Postulat S. Mater Ecclesia.” This form is found in the Sacramentary of Gregory, and also in the old English Pontificals. It was, however, thought to be too bold a presumption, and was changed into a declaration by the Archdeacon in his own name.

[*I have enquired, &c.*] In the Sacramentary of Gregory, the answer of the Archdeacon was, “Quantum humana fragilitas nosse sinit et scio et testificor ipsos dignos esse ad hujus onus officii.” In our own form the words, “as far as human frailty suffereth,” being regarded as too vague an expression, and offering a shelter for prevarication, were omitted; whilst the assertion, “I know and bear witness,” was softened down by the tempered language, “I think them so to be.”

[*commending such, &c.*] In the Sacramentary of St. Gregory, the Bishop in the “Benedictio Diaconi” thus commends those who are to be ordained, to the prayers of the people: “Oremus, dilectissimi, Deum Patrem Omnipotentem, ut super hunc famulum suum, quem in sacrum ordinem Diaconatus officii dignatur assumere, Ille benedictionis sue gratiam clementer effundat, eique donum consecrationis propitius indulgeat per quod eum ad premia eterna perducat, auxiliante Domino nostro Jesu Christo.” The Prayer in the Pontifical of Egbert is very similar, and differs

only in the insertion of the clauses, “et preces nostras clementer exaudiat, ut suo eum prosequatur auxilio et sua potius electione justificet,” between “indulgeat” and “per quod.” In the Sarum Pontifical the same Prayer occurs, differing merely in a few words. It stands immediately after the ordination. There is also in the Winton Pontifical a similar Prayer, in which, after “hos famulos tuos” are inserted the words, “quorum nomina hic recitantur.” The same Prayer occurs after the Ordination in Harl. MS. 2906, fo. 8, b., as the Præfatio with a different ending, being preceded by the address to the people: “Commune votum communis oratio prosequatur, ut hi totius ecclesie precæ qui in Diaconatus Ministerium præparantur Leviticæ benedictionis ordine clarescant, et spirituali conversatione præfulgentes, gratia sanctificationis eluceant.” This address in the Winton Pontifical succeeds the delivery of the Gospel [Maskell, Mon. Rit. iii. 199].

[*The Litany*] The Rubric in the MS: Harl. 2906, fo. 8, a Pontifical of the tenth century, is, “Tunc prosternat se pontifex cum Archidiacono coram altari super stramenta cum hisque qui consecrandi sunt, et schola imponat letaniam;” and in the Cotton MS. Tib. c. i. fo. 142, b., which is perhaps earlier: “Pontifex super tapetia et qui consecrandi sunt super pavimentum proster-

that we most righteously have deserved; and grant, that in all our troubles we may put our whole trust and confidence in thy mercy, and evermore serve thee in holiness and pureness of living, to thy honour and glory; through our only Mediator and Advocate, Jesus Christ our Lord.

Amen.

¶ *Then shall be sung or said the Service for the Communion, with the Collect, Epistle, and Gospel, as followeth.*

The Collect.

Matt. xxviii. 18.
20.
Eph. iv. 8. 11.
1 Cor. xii. 28.
Heb. v. 4. 5.
Acts vi. 3. 5. 6.
1 Tim. i. 2.
Acts xiii. 2.
John xiv. 16. 17.
26. xvi. 13.
xvii. 17.
Col. i. 9—11.
1 Tim. iii. 8—13.
iv. 12.
Tit. ii. 1. 7. 8.
Col. iv. 17.
1 Cor. xiv. 12.
1 Pet. iv. 11.

ALMIGHTY God, who by thy Divine Providence hast appointed divers Orders of Ministers in thy Church, and didst inspire thine Apostles to choose into the Order of Deacons the first Martyr S. Steven, with others; Mercifully behold these thy servants now called to the like Office and Administration; replenish them so with the truth of thy doctrine, and adorn them with innocency of life, that, both by word and good example, they may faithfully serve thee in this Office, to the glory of thy Name, and the edification of thy Church; through the merits of our Saviour Jesus Christ, who liveth and reigneth with thee and the Holy Ghost, now and for ever. *Amen.*

The Epistle.

1 Tim. iii. 8[—13].

* * * * *

¶ *Or else this, out of the Sixth of the Acts of the Apostles.*

Acts vi. 2[—7].

* * * * *

DOMINE sanete, Pater fidei, spei, gratiæ, et perfectuum munerator, qui in cœlestibus et terrenis ministeriis ubique dispositis per omnia elementa voluntatis tuæ diffundis effectum: hos quoque famulos tuos speciali dignare illustrare aspectu, ut, tuis obsequiis expediti, sanctis tuis altaribus ministri puri accrescant, et indulgentia puriores, eorum gradu, quos apostoli in septenario numero, beato Stephano duce ac prævio, Sancto Spiritu auctore, elegerunt, digni existant et virtutibus universis, quibus tibi servire oportet, instructi polleant. Per Dominum. In unitate ejusdem.

nantur, ac tunc agatur letania, et inter alia dicatur: Ut fratres nostros ad sacrum ordinem electos in vera religione conservare digneris." The admonition to the Deacons, in the Winchester Pontifical, immediately follows their approach to the Bishop, nor does there seem in that age, according to the use of that Church, to have been a Litany appointed [Maskell, Mon. Rit. iii. 191].

Then shall he sung or said, &c. In the Harl. MS. 2906, fo. 8, the Rubric is, "Qua (i. e., letania) finita erigat se pontifex et ascendunt ipsi electi ad sedem pontificis, et benedicat eos ad quod vocati sunt, et descendant et stent in ordine suo. Benedictione accepta Archidiaconus imponat Evangelium, et cætera ex more."

The Rubric in the Sacramentary of Gregory is similar: "Litania expleta ascendunt ipsi ad sedem pontificis, et benedicat eos ad quod vocati sunt, et descendentes stant in ordine suo benedictione percepta." See also Pont. Egberti, p. 9. In Lacy's Pontifical it is directed: "Missam in qua ordinatus est totaliter audiat. Ordines non conferuntur a quolibet, nec cuilibet, nec qualibet die, nec qualibet hora diei, sed tempore Missæ."

The Collect] This corresponds to the Consecratio in the Sacramentary of St. Gregory and early Pontificals. Abbé Migno makes the following note:—"In primo Theod. hæc omnia [that is, the presentation of the Candidates and the Litany] omituntur usque ad 'Oremus dilectissimi,' cui pramittuntur orationes ad ordinandos Diaconos, eodem ritu cætera pro ordin. Presbyteri et Episcopi habentur." [lxxviii. 220.]

The Apostolical Constitutions contain a similar prayer:—"Ἐπίφανον τὸ πρόσωπόν σου ἐπὶ τὸν δούλον σου τόνδε τὸν προχειρισμένον σοὶ εἰς διακονίαν, καὶ πᾶσιν αὐτὸν Πνεύματος Ἁγίου καὶ δυνάμεως, ὡς ἐπέλεξας Στέφανον τὸν μάρτυρα, καὶ καταξίωσον αὐτὸν εὐαρέστως λειτουργήσαντα τὴν ἐγχεισθείσαν αὐτῷ διακονίαν ἀπρέπτος, ἀμέμπτος, ἀνεγκλήτως, μείζονος ἀξιώθηται βαθμοῦ [Const. Apost. l. viii. exviii. Assem. P. iv. p. 112. Morin, P. ii. p. 375].

Compare also the Collect in the Ordinal of the Syro-Nestorians, as translated by Morin: "Tu per gratiam Tuam elegisti Ecclesiam Tuam Sanctam, et suscitasti in ea Apostolos Sacerdotes et doctores ad perfectionem Sanctorum, et in ea quoque posuisti

¶ *And before the Gospel, the Bishop, sitting in his chair, shall cause the Oath of the Queen's Supremacy, and against the power and authority of all foreign Potentates, to be ministered unto every one of them that are to be Ordered.*

The Oath of the Queen's Sovereignty.

* * * * *

¶ *Then shall the Bishop examine every one of*

them that are to be Ordered, in the presence of the people, after this manner following.

Do you trust that you are inwardly moved by the Holy Ghost to take upon you this Office and Ministration, to serve God for the promoting of his glory, and the edifying of his people?

Matt. vi. 33.
James i. 17.
2 Cor. xlii. 5.
Gal. vi. 3—5.
2 Cor. v. 14.
xii. 19.
John viii. 50.

Answer.

I trust so.

Diaconos, et quemadmodum elegisti Stephanum et socios ejus, ita nunc quoque, Domine, secundum misericordiam Tuam da servis Tuis istis gratiam Spiritus Sancti ut sint ministri electi in Ecclesia Tua sancta, et serviant Altari Tuo puro cum puro corde, et conscientia bona, et splendeant in operibus justitiæ ministrantes mysteriis Tuis divinis." [P. ii. p. 378.]

The Epistle and Gospel. "In Ordinatione Diaconorum Lectio Epistolæ B. Pauli Apost. ad Timoth.: 'Diaconos constitue pudicos.' Sequentia S. Evangelii secundum Johannem, 'Nisi granam frumenti.'" [D. Hieron. Comes ap. Pamel. ii. 60.]

In the Gallican Church, the rubric was, "Legenda quando Diaconus ordinatur Lectio Ezechiel, Prop. c. xlii. 15, 16. Epist. S. Pauli ad Tim. iii. 8—15" [Mabillon, l. ii. No. lxxviii.], and the

Gospel "Evang. S. Lucæ ix. 57. 62" [Ib. p. 170]. In the Syro-Maronite Ordinal, the rubric is, "Deinde traditur ei ut legat Epistolam Apostoli Pauli ad Timoth. 'Similiter Diaconi'" [Morin, P. ii. p. 329]. In the German Liturgy, the Epistle was 1 Tim.: "Fidelis sermo omni acceptione dignus;" and the Gospel St. John: "In illo tempore Jesus dixit . . . Pater Meus Qui est in cælis" [Gerbert, 416. 443]. In the ancient Ordo Romanus the Epistle is from 1 Tim., "Fratres Diaconos . . . in Christo Jesu Domino nostro." It is directed to follow the Introit and Prayer. In the Sarum Pontifical, the Gospel is St. Luke iii. 1—6.

Oath of the Queen's Supremacy. The following are the two forms successively used in Ordinations from 1661 until 1865. The third form is that now ordered to be taken—

Form of Oath printed in Sealed Books.

I, *A. B.*, do utterly testify and declare in my conscience, That the King's Highness is the only Supreme Governour of this Realm, and of all other his Highnesses Dominions and Countries, as well in all Spiritual or Ecclesiastical things or causes, as Temporal: And that no foreign Prince, Person, Prelate, State, or Potentate hath or ought to have any jurisdiction, power, superiority, pre-eminence or authority Ecclesiastical or Spiritual within this Realm. And therefore I do utterly renounce and forsake all foreign jurisdictions, powers, superiorities and authorities; and do promise, That from henceforth I shall bear faith and true allegiance to the King's Highness, His Heirs and lawful Successors, and to my power shall assist and defend all jurisdictions, priviledges, pre-eminences and authorities granted or belonging to the King's Highness, His Heirs and Successors, or united and annexed to the Imperial Crown of this Realm. So help me God, and the contents of this Book.

Form of Oath ordered by 1 W. & M. c. 8.

I, *A. B.*, do swear, that I do from my heart abhor, detest, and abjure, as impious and heretical, that damnable Doctrine and Position, That Princes excommunicated or deprived by the Pope, or any authority of the See of Rome, may be deposed or murdered by their Subjects, or any other whatsoever. And I do declare, that no foreign Prince, Person, Prelate, State, or Potentate, hath or ought to have any jurisdiction, power, superiority, pre-eminence, or authority, ecclesiastical or spiritual, within this Realm. So help me God.

Form of Oath ordered by 21 & 22 Vict. c. 48.

I, *A. B.*, do swear that I will be faithful and bear true allegiance to Her Majesty Queen Victoria, and will defend her to the utmost of my power against all conspiracies and attempts whatever which shall be made against her person, crown, or dignity; and I will do my utmost endeavour to disclose and make known to Her Majesty, her heirs and successors, all treasons and traitorous conspiracies which may be formed against her or them; and I do faithfully promise to maintain, support, and defend, to the utmost of my power, the succession of the Crown, which succession, by an Act, intituled "An Act for the further limitation of the Crown, and better securing the rights and liberties of the subject," is and stands limited to the Princess Sophia, Electress of Hanover, and the heirs of her body being Protestants, hereby utterly renouncing and abjuring any obedience and allegiance unto any other person claiming or pretending a right to the crown of this realm; and I do declare, that no foreign prince, person, prelate, state, or potentate, hath or ought to have any jurisdiction, power, superiority, pre-eminence, or authority, ecclesiastical or spiritual, within this realm; and I make this declaration upon the true faith of a Christian. So help me God.

In the first Prayer Book of Edward VI. the confirmation ran, "So help me God, all Saints, and the holy Evangelists;" owing to the remonstrance of Bp. Hooper it was altered to, "So help me God, through Jesus Christ" [Zur. Lett. iii. 81. 566. Hooper's Early Writings, 479]. In 1559, an entirely new form of oath was inserted, with a corresponding alteration in the rubric preceding and introducing it [Pref. Lit. Serv., Park. Sec. p. xxi., p. 281].

By the Clergy Subscription Act, 1865, 28 & 29 Vict. c. cxxii. § xi., Oaths are not to be administered during the Services of Ordination; but this does not extend to or affect the oath of due obedience to the Archbishop taken by Bishops on consecration,

§ xii.; by § iv. every person about to be ordained Priest or Deacon, shall, before Ordination, make and subscribe the declaration of assent, and take and subscribe the oath of allegiance and supremacy; and the Bishop's oath of due obedience to the Archbishop is retained.

Then shall the Bishop examine. The candidate is required to answer plainly to several questions, that is, "clara voce," and to make certain promises, which, as Bishop Beveridge says, "being made so solemnly before God and His Church, are certainly as binding as if made upon oath, and ought to be as religiously observed;" "ut non solum habeat Dei timorem sed etiam coram omnibus denunciationem et professionem erubescat" [Novell. Just.

The Bishop.

Matt. iv. 18—22.
vii. 22, 23.
Heb. v. 4, 5.
Rom. xiv. 5.

DO you think that you are truly called, according to the will of our Lord Jesus Christ, and the due order of this Realm, to the Ministry of the Church?

Answer.

I think so.

The Bishop.

2 Pet. iii. 2.
2 Tim. iii. 14—16.
1 Thess. ii. 13.

DO you unfeignedly believe all the Canonical Scriptures of the Old and New Testament?

Answer.

I do believe them.

The Bishop.

WILL you diligently read the same unto the people assembled in the Church where you shall be appointed to serve?

Exod. xxiv. 7.
Luke iv. 16.
Col. iv. 16.
Acts xiii. 15.

Answer.

I will.

The Bishop.

Numb. iii. 5—7.
Acts vi. 1—5.
viii. 5, 12.

IT appertaineth to the Office of a Deacon, in the Church where he shall be appointed to serve, to assist the Priest in Divine Service, and specially when he ministereth the holy Communion, and to help him in the distribution thereof, and to read holy Scriptures and Homilies in the Church; and to instruct the youth in the Catechism; in the absence of the Priest to baptize infants, and to preach, if he be admitted thereto by the Bishop. And furthermore, it is his Office, where provision is so made, to search for the sick, poor, and impotent people of the Parish, to intimate their estates, names, and places where they dwell,

Finita litania, redeant sacerdotes electi ad loca sua, remanentibus Levitis ad consecrandum, et episcopus dicat eis sine nota, sedendo. Salisbury Use.

DIACONUM oportet ministrare ad altare, evangelium legere, baptizare, et prædicare.

Auth. Coll. 1, tit. vi. cap. i. § 9, p. 19, Lugd. 1581]. All these interrogations are in accordance with St. Paul's demands of a good life, good government, and that second part of the pastoral office, sound and good doctrine according to the Word of Life, to be found in the Minister of God [1 Tim. v. 17]. They relate [I.] To a profession of the Catholic Faith, and the assurance of the candidates that they are lawfully called to be Ministers of the Church of England [Art. XXIII.]. [II.] A promise is given to observe the discipline of the Church, according to her laws and constitutions. [III.] A profession of obedience is made to ecclesiastical governors. They are grounded on the questions put to Bishops in ancient formularies, and were added to secure uniformity in the services. But they follow ancient precedent as given by the Codex Thuanus of the ninth century: "Primitus cum venerint ordinandi Clerici ante Episcopum debet Episcopus inquirere unumquemque si literatus, si bene doctus, si docibilis, si moribus temperatus, si vita castus, si sobrius, si domui bene præesse sciat, et ante omnia si Fidei documenta pleniter sciat. Et tunc demum in conspectu Episcopi vel Cleri sive populi polliceri debet quæ subter inserta sunt. Ut Sacras Scripturas quotidie meditetur et populum doceat; ut intentus sit lectioni assiduæ. Ut eleemosynarius, hospitalis, humilis, benignus, misericors, largus, ecclesiasticus prædicator, visitator infirmorum. Ut Ecclesiam suam in officiis divinis frequentare non negligat. Ut populum ad eam vel ad se venientem bene recipiat et instruat. Ut Canonibus pleniter discat et intelligat. Ut ecclesia una, i. e. sua cui ordinatus est, contentus sit. Ut sine jussione sui Episcopi extra suam ecclesiam

non proficiscatur" [Morin de Sacr. Ordin. pt. ii. p. 252, D.]. By the eleventh Council of Toledo, A.D. 675, c. x.: "Unusquisque qui ad ecclesiasticos gradus est accessurus non ante honoris consecrationem accipiat quam placiti sui innotatione promittat ut fidem Catholicam sincera cordis devotione custodiens, juste ac pie vivere debeat; et ut in nullis operibus suis Canonicis regulis contradicat; atque ut debitum per omnia honorem atque obsequii reverentiam præminenti sibi unusquisque dependat" [Labbe, Conc. tom. vii. 568, B.]. In 818, the Council of Chalons forbade the practice of Bishops exacting from Candidates an oath that they were worthy, would not contravene the Canons, and would obey the Bishop who ordained them, and the Church in which they were ordained, this being prejudicial to diocesan rights [c. xiii. Labbe, tom. ix. col. 362, C.].

It appertaineth, &c. By the fifth Canon of the Council of York, 1195, "decrevimus etiam ut non nisi summa et gravi necessitate diaconus baptizet" [Wilkins, Conc. i. 501]. So by the Council of London, 1200, c. iii., "Ut non liceat diaconis baptizare, nisi duplici necessitate, viz., quia sacerdos non potest vel absens vel stulte non vult, et mors imminet puero" [Ib. 505]. And a Provincial Constitution gives similar directions [Ib. p. 636]. This question in the Sarum Pontifical occurs as an address to the candidate after the Litany, when the Deacons to be ordained Priests have returned to their places (see above). The admonition is much longer in the Winton Pontifical [Maskell, Mon. Rit. iii. 191].

unto the Curate, that by his exhortation they may be relieved with the alms of the Parishioners, or others. Will you do this gladly and willingly?

Answer.

Heb. xiii. 6. I will so do, by the help of God.

The Bishop.

1 Tim. iii. 8-13.
iv. 12, 16.
2 Tim. ii. 22.
Ps. cxix. 9.
1 Pet. v. 2, 3.

WILL you apply all your diligence to frame and fashion your own lives, and the lives of your families, according to the Doctrine of Christ; and to make both yourselves and them, as much as in you lieth, wholesome examples of the flock of Christ?

Answer.

I will so do, the Lord being my helper.

The Bishop.

WILL you reverently obey your Ordinary, and other chief Ministers of the Church; and them to whom the charge and government over you is committed, following with a glad mind and will their godly admonitions?

1 Pet. v. 5.
ii. 13.
Heb. xiii. 17.
1 Cor. xiv. 33.

Answer.

I will endeavour myself, the Lord being my helper.

¶ Then the Bishop laying his hands severally upon the head of every one of them, humbly kneeling before him, shall say,

Numb. xxvii. 18.
20, 23.
Acts xiii. 2, 3.
vi. 6.
2 Tim. ii. 2.
i. 6.
1 Tim. iii. 10.
Col. iii. 17.

TAKE thou Authority to execute the Office of a Deacon in the Church of God committed unto thee; In the Name of the Father, and of the Son, and of the Holy Ghost. Amen.

Quibus inclinantibus, solus episcopus qui eos Salisbury Use. benedicit, manum super capita singulorum ponat, dicens solus secrete, Accipe Spiritum Sanctum Tunc ponat singulis, super sinistrum humerum, stolam usque ad ascellam dexteram subtus, dicens sine nota :

IN nomine Sanctæ Trinitatis, accipe stolam immortalitatis: imple ministerium tuum, potens est enim Deus ut augeat tibi gratiam, qui vivit et regnat

the Curate] Towards the latter end of the sixteenth century Bishops restricted the word (which had been exclusively applied, as here properly, to parish Priests having cure of souls, in its subordinate and present sense) to their vicars [Art. 1576, § 28. Bancroft, Vis. Art. 1605, § 25]. These were formerly called "Substitutes" [Canons 1603, clxix. Comp. Cardw. Conf. ch. viii. p. 342. Grindal's Letters, xiii. p. 246]. Sheldon, however, employs it in the sense of a deputy in 1665 [Cardw. Doc. Ann., No. cxxxix., clii.].

Will you apply, &c.] A hint for this question may probably have been taken from the following prayer in the Sacramentary of St. Gregory: "Exaudi, Domine, preces nostras et super hunc famulum Tuum Spiritum Tuus benedictionis emitte, ut celestis munere ditatus et Tuæ gratiam possit majestatis acquirere et bene vivendi aliis exemplum præbere."

your Ordinary] That is [1] the Bishop, as having ordinary jurisdiction in causes ecclesiastical, of common right, and of course: [2] Chancellors, Commissaries, Officials, and Archdeacons. So Lyndewood states that ordinaries are those "quibus competit jurisdictio ordinaria de jure privilegii vel consuetudine" [Lyndew. Prov. l. tit. ii.].

Then the Bishop laying his hands, &c.] The Salisbury Pontifical [see above] enjoins the words, "Accipe Spiritum Sanctum." The Bangor MS. also enjoins these words, but the Winton Pontifical does not. The modern Roman form, which does not mention the office of the Deacon, is, "Accipe Spiritum Sanctum ad robur, et ad resistendum diabolo, et tentationibus ejus. In nomine Domini." It is interpolated in the long prayer which is called Præfatio, beginning, "Honorum dator." Martene says that this form is not earlier than the thirteenth century. It does not occur in the Winton Pontifical, nor in the Brit. Mus. Pont. [MS. Harl. 2906], and for the first time appears in the Bangor Use. A clause in the prayer called the Consecration, correspond-

ing to the English Collect, "Almighty God, giver of all good things," does occur in the Harl. Pontifical, and in those of Egbert and Lacy, "Emitte Spiritum Sanctum," and has been distorted into "the form" by Catalani and Martene. The Greek Church uses this form, substituting Priest or Deacon in the several ordering of both, 'Η Θεία χάρις ἡ πάντοτε τὰ ἀσθενῆ θεραπεύουσα καὶ τὰ ἐλλείποντα ἀπαληροῦσα, προχειρίζεται τὸν δεῖνα τὸν εὐλαβέστατον ὑποδιάκονον εἰς διάκονον [Morin de Sac. Ordin. pt. i. p. 79, D.].

laying his hands severally] As regards this rite, the words of the fourth Council of Carthage, c. iv. [Mansi, tom. iii. col. 951], are, "Diaconus cum ordinatur solus Episcopus qui eum benedicit manum super caput illius ponat, quia non ad sacerdotium sed ad ministerium consecratur" [Morin, p. 260]. They are incorporated in the Sacramentary of St. Gregory, and the old "Ordo Romanus." But in the Gelasian Sacramentary, and an English Pontifical of Rouen, this clause is inserted, "Reliqui omnes Sacerdotes juxta manum Episcopi caput illius turgent, quia non ad sacerdotium," &c. Durand [Ration. lib. ii. c. ix. § 14] observes, "We read in the Acts of the Apostles that they set them in the sight of the Apostles, and they prayed and laid hands on them. Hereby we see that not only the Bishop, but the Priests that stand by, ought to lay hands upon the Deacon at Ordination." And Amalarius [de Offic. Eccles. lib. ii. c. xii.] agrees with Durand in objecting to the imposition of the hands of the Bishop alone, founding his argument on the same text: but Menard answers the objection, saying, "As this was the first Ordination, and all the Apostles were assembled, it was right that they should all lay on hands, although an unnecessary act, as only one of them would have been sufficient" [M. Sacram. Greg. Notæ, Migne, lxxviii. 484]. In the Harl. MS. 2906, fol. 8, b., the rubric is, "Et omnes qui ordinandi sunt oblationes deferant ad manus Episcopi cum ab eo ordinationem

¶ Then shall the Bishop deliver to every one of them the New Testament, saying,

2 Tim. ii. 15.
Rom. vi. 7, 8.
Luke ix. 3. c.

TAKE thou Authority to read the Gospel in the Church of God, and to preach the same, if thou be thereto licensed by the Bishop himself.

¶ Then one of them, appointed by the Bishop, shall read the Gospel.

Luke xii. 35 [—38].

* * * * *

¶ Then shall the Bishop proceed in the Communion, and all that are Ordered shall tarry, and receive the holy Communion the same day with the Bishop.

¶ The Communion ended, after the last Collect, and immediately before the Benediction, shall be said these Collects following.

Gen. xvii. 1.
James i. 17.
1 Pet. v. 5.
Rom. xii. 3.
1 Tim. iv. 14—16.
1 Cor. xiv. 40. 32.
Acts xxiv. 16.
2 Cor. i. 12.
Heb. xiii. 9.
Eph. vi. 10.
2 Tim. ii. 1—3.
1 Tim. iii. 13—15.
Luke xvi. 10.
2 Thess. ii. 16, 17.

ALmighty God, giver of all good things, who of thy great goodness hast vouchsafed to accept and take these thy servants unto the Office of Deacons in thy Church; Make them, we beseech thee; O Lord, to be modest, humble, and constant in their Ministration, to have a ready will to observe all spiritual Discipline;

. . . . Post hæc tradat eis librum evangeliorum Salisbury Use. dicens sine nota :

IN nomine Sanctæ Trinitatis, accipe potestatem legendi evangelium in ecclesia Dei, tam pro vivis quam pro defunctis in nomine Domini. Amen. . .

¶ Ultimo concludendo ei qui lecturus est evangelium.

DOMINE sancte, Pater omnipotens, æterne Deus, honorum dator, ordinumque distributor, ac officiorum dispositor . . . Super hos quoque famulos tuos, quæsumus Domine, placatus intende, quos tuis sacrariis servituros in officium diaconii suppliciter dedi~~x~~camus. . . . Abundet in eis totius formæ virtutis, auctoritas mo-

accipiant. Ordinatio Diaconi: Diaconus cum ordinatur, solus Episcopus qui eum benedicit manus super caput ejus imponit, quia non ad sacerdotium sed ad ministerium consecratur; et alloquitur populum his verbis: Commune votum." The Royal MS. and Codex of Noyon, as Migne observes, required the Priests to touch the Deacon's head.

the New Testament "Tradat ei Episcopus sanctum Evangelium, dicens, Accipe istud volumen Evangelii, lege et intellige et alius trade et opere adimple" [Ex. Anglic. Cod. Rotom. Eccles. ann. DCCC., Morin, p. 232, E. Ord. ii. Pont. Gemmet. ante ann. DCCC., Martene, ii. col. 109, A. Ord. xi. Pont. Becc. ante ann. D., Ib. col. 179, B.].

"Accipite licentiam legendi Evangelium in Ecclesia Dei in nomine Domini" [Codex Bellovac. ann. DCL., Morin, p. 270, E. Ord. vi. Pont. Suess. ante ann. DC., Ib. col. 140, E. Ord. xv. Mogunt. ann. circa cccc., col. 219, D. Ord. xvii. Pont. Noviom. ann. circa DCCC., Martene, tom. ii. col. 137, D. Ord. vii. Pont. Noviom. ann. cccc., col. 209, C. Ord. xvii. Pont. MS. Bibl. Colb. col. 234, C. Ord. xiii. Pont. Camerac. ann. D., col. 190, D.].

Martene says, "The most ancient Pontificals written before the ninth century, with the exception of the English copies, do not mention the delivery of the Gospels in the Ordering of Deacons. I say with the exception of English Pontificals, for the Pontificals of Archbishop Egbert of York, of the eighth century [tom. ii. col. 98, D.], of Jumieges of the ninth century [Ib. 109, A.], of Rouen of the same date [Morin, p. 232, E.], which certainly were designed for the English use, expressly notice the delivery of the Gospels; so, therefore, this was a solemn rite in England, and found in all the rituals we have seen, it is clearly of English origin" [de Ant. Eccl. Rit. lib. 1, c. viii. art. ix. § 6, 7, tom. ii. col. 60, D., 61, A.]. An earlier Pontifical of Bec, ante ann. D., also mentions it [Ib. col. 179, B.]. Ivo of Chartres says, "Deacons receive the text of the Gospels from the Bishop, whereby they understand that they ought to be preachers of the Gospel" [de Reb. Eccles. Sum. ii. apud Hitortp. col. 776, D.]. Neither Rabanus Maurus, Isidore, Alcuin, nor Amalarius, mention the rite, but

Durand says that as he wished to conform to the use of the other Churches, he wrote in the Ordinal of his church of Anicia, on the margin, that the book of the Gospels was to be given to the Deacon with a form of words [in IV. Sent. dist. xxiv. qu. 3]. In Spain [IV. Counc. Toledo, c. 27], Deacons do not seem to have read the Gospel.

In the Syro-Nestorian Church this rubric occurs: "Afterwards the Archdeacon delivers the book of the Apostle to the Bishop, who gives it to each of those that are to be ordained, saying, 'He is set apart, sanctified, perfected, and consecrated for the Ecclesiastical Ministry of a Deacon in the name of the Father,' &c. The Bishop takes the book from the hand of each of them, and delivers it to the Archdeacon" [Morin, pt. ii. p. 379]. The Nestorian Form enjoins the delivery of the Epistles to the Deacon, and the Gospel to the Priest [Ib. pt. iii. Exerc. ix. de Diac. c. i. § 16, p. 136].

one of them . . . shall read the Gospel [In the Greek Church the Deacon or Priest read the Gospel [Const. Apost. l. ii. c. lvii.]: at Constantinople the Archdeacons. But Sozomen adds, in some churches, the Deacons, in others, the Priests, read the Gospel [H. E. lib. vii. cap. xix.]. In the time of St. Jerome in the Western Church the duty was reserved to Deacons [Ep. xciii. ad Sabinian. Op. tom. iv. col. 758], and by St. Gregory [Epist. App. v. tom. ii. col. 1289, A.]. The Council of Vaison, A.D. 529, c. ii., declared they were worthy to read it [Labbe, v. col. 822, C.], and Isidore [de Div. Off. l. ii. c. viii.] and Honorius [lib. i. c. clxxx.] mention that they did so [ap. Hitortp. col. 208, D., 1226, E., 1238, D.]. The Greek Church assigns the reading of the Gospel in the Holy Communion to them, but there is no mention of a delivery of the Gospel to them at ordination in the Euchologium.

licensed by the Bishop [In the Sacramentary of St. Gregory, at the delivery of the stole to the Deacon, the Bishop says, "Imponimus ut præcones regis cœlestis irreprehensibiliter existere mereamini." Archbishop Whitgift says, "Surely I think no man is admitted into the Ministry but he is permitted to preach in his

that they having always the testimony of a good conscience, and continuing ever stable and strong in thy Son Christ, may so well behave themselves in this inferior Office, that they may be found worthy to be called unto the higher Ministries in thy Church; through the same thy Son our Saviour Jesus Christ, to whom be glory and honour world without end. *Amen.*

PREVENT us, O Lord, in all our doings with thy most gracious favour, and further us with thy continual help; that in all our works begun, continued, and ended in thee, we may glorify thy holy Name, and finally by thy mercy obtain everlasting life; through Jesus Christ our Lord. *Amen.*

THE peace of God, which passeth all understanding, keep your hearts and minds in the knowledge and love of God, and of his Son Jesus Christ our Lord: And the blessing of God Almighty, the Father, the Son, and the Holy Ghost, be amongst you, and remain with you always. *Amen.*

¶ *And here it must be declared unto the Deacon, that he must continue in that Office of a Deacon the space of a whole year (except for reasonable causes it shall otherwise seem good unto the Bishop) to the intent he may be perfect, and well expert in the things appertaining to the Ecclesiastical administration. In executing whereof if he be found faithful and diligent, he may be admitted by his Diocesan to the Order of Priesthood, at the times appointed in the Canon; or else, on urgent occasion, upon some other Sunday, or Holy-day, in the face of the Church, in such manner and form as hereafter followeth.*

own cure without further licence, except it be upon some evil usage of himself afterwards either in life or doctrine" [Defence, &c., Tr. xiii. vol. iii. p. 41].

Ordination and Mission are distinguished in St. Mark iii. 14; St. Matt. x. 5; St. Luke vi. 13; ix. 2; and in the XXIII. Article; the XXXVI. and L. Canons of 1604 require a licence. The Bishop under Christ being the fountain of spiritual power in his Diocese, by such an act or issue of his jurisdiction, delegates a portion of his authority, not absolutely, but revocably, to the clerk deputed to perform Ecclesiastical acts. A Rector or Vicar is entrusted with this Mission by Institution, "Missus a jure ad locum et populum curæ suæ:" a Curate by licence. No power can deprive a Clerk, or make his Orders void, in respect to the

desta, pudor constans, innocentiae puritas, et spiritualis observantia disciplinae. In moribus eorum praecepta tua fulgeant, ut suae castitatis exemplo imitationem sancta plebs acquirat, et bonum conscientiae testimonium praefidentes, in Christo firmi et stabiles perseverent, dignisque successibus de inferiori gradu per gratiam tuam capere potiora mereantur.

Terminando secreta: Per eundem Dominum nostrum, Jesum Christum, Filium tuum, qui tecum vivit et regnat in unitate ejusdem.

ACTIONES nostras, quaesumus, Domine, et aspirando praeveneri, et adjuvando proseguere; ut cuncta nostra operatio et a te semper incipiat, et per te coepta finiatur. Per.

BENEDICTIO Dei Patris et Filii, et Spiritus Sancti et pax Domini sit semper vobiscum.

Salisbury Use.

Salisbury Use.
Canon Missae ad
Sanctum Gregorium.
Sabbatum in XII. lect.
mensis primi.

MS. Leofric.
Exon. fol.
cccxxxii.

inward power conferred upon him by ordination; but admission, suspension, or deposition is competent to the Ordinary, in respect to the outward exercise of that power and ordinary ministration publicly in the Church, as well as in private, either for a set time, or during his life. Admission is given by a licence, the formal permission to perform certain sacred functions in specified places, to which an unbeneficed curate shall be appointed.

[*Almighty God, giver of all good things*] This prayer is also to be found in an Anglican Pontifical of the Monastery of Jumieges [ante ann. dcccc.], and in another of St. Dunstan [Martene de Ant. Eccl. Rit. vol. ii. p. 39]. Also in Egbert's Pontifical, and in Lacy's.

THE
FORM AND MANNER
OF
ORDERING OF PRIESTS.

1 Cor. xiv. 26. ¶ *When the day appointed by the Bishop is come, after Morning Prayer is ended, there shall be a Sermon or Exhortation, declaring the Duty and Office of such as come to be admitted Priests; how necessary that Order is in the Church of Christ, and also how the people ought to esteem them in their Office.*

Exod. xxviii. 2. 4. ¶ *First, the Arch-Deacon, or, in his absence, one appointed in his stead, shall present unto the Bishop (sitting in his chair near to the holy Table) all them that shall receive the Order of Priesthood that day (each of them being decently habited) and say,*

¶ *Deinde (i. e. post Evangelium) dicat Archidiaconus: Recedant qui ordinati sunt diaconi; accedant qui ordinandi sunt sacerdotes.* Salisbury Use.

Sermon or Exhortation] "Legebantur ordinandis Canones ecclesiastici qui de sacris ordinationibus agunt, aut Episcopus ipse sermonem ad eos exhortatorium habebat de dignitate officii-que singulorum ordinum, nisi id jam præstitisset Archidiaconus, qui (ut præscribunt antiqui libri rituales) eos de omnibus in suo ordine agendis prius instruxisse debuerat." [Martene, lib. i. cviii. art. viii. § 3, tom. ii. p. 48.] In the Winton Pontifical is this rubric, "Hos [Sacerdotes] domnus præsul de dignitate officii sacerdotalis diligentur instruens dicat." Then follows an Exhortation, setting forth the duty and office of such as are to be ordained Priests. [Maskell, Mon. Rit. iii. 202.]

First, the Arch-Deacon] In a Pontifical of Corbey of the twelfth century, the Archdeacon comes and presents him that is to be ordained Priest to the Bishop. In the Greek Church, the rubric is: "He that is to be ordained is led up by the Archpriest, and the Archdeacon coming forward shall say, 'Let us attend;' then the Patriarch reads the citation or diploma of election." [Eucholog. Morin, P. ii. p. 63.] In a later Ordinal, the Archpriest presents the Deacon for priesthood. By the Coptic Ordinal, when the Candidate is presented, the Priests first give testimony of his good works, and his knowledge of the word of doctrine, that he is gentle, kind, compassionate; that his wife is such as the law and Canon require; and that he is a Deacon. The Archdeacon says, "May the peace of our Lord be upon this man standing at Thy altar, and expecting Thy heavenly gifts, that he may be raised from the Order of Deacons to the Priesthood" [Ib. p. 445, E.]; and by the Syro-Nestorian Ordinal the Archdeacon leads him by the right hand, saying, "We offer to Thy holiness, holy Father, elect of God, my Lord Bishop, this God-loving man, who standeth here that he may receive the laying on of the divine hand to pass from the Order of Deacon to the Priesthood." [Ib. p. 336.]

or, in his absence] "Every Archbishop, because he must occupy eight Chaplains at Consecrations of Bishops, and every Bishop, because he must occupy six Chaplains at giving of orders, may every of them have two Chaplains over and above the number above limited to them" [21 Hen. VIII. c. xiii. § 24]. The number of Chaplains was intended to add dignity to the presence of an Archbishop, and one of the Bishop's might act as the deputy of the Archdeacon, besides assisting in the laying on of hands upon Deacons to be ordained Priests.

decently habited] The Salisbury Pontifical directs, "Omnes etiam provideant de vestibus sacris sibi necessariis." Also immediately before the Litany is the rubric, "Deinde accedentes qui ordinandi sunt Diaconi et Sacerdotes cum vestibus suis," &c. The rubric in the Bangor Pontifical is, "Deinde accedentes qui ordinandi sunt Diaconi et Sacerdotes cum vestibus suis et titulis, et stantibus cunctis," &c. The Winchester Pontifical agrees with the Exeter in calling up the Deacons and Priests separately.

The rubric in the Churching of Women uses the words "*decently apparelled*," and the Bishops in the Savoy Conference have explained the word "εὐσχημότως, in a fit scheme, habit or fashion, decently; and that there may be uniformity in those decent performances, let there be a ῥῆξις, rule or canon for that purpose." [Cardw. Conf. 346.] "The Ministers" included "garments under the name of decency" [p. 338], and the Bishops answer, "Reason and experience teaches that decent ornaments and habits preserve reverence, and are therefore necessary . . . to the solemnity of religious worship. And in particular no habit more suitable than white linen, which resembles purity and beauty, wherein angels have appeared [Rev. xv.], fit for those whom the Scripture calls angels, and the habit was ancient [Chrys. Hom. lx. ad Pop. Antioch. p. 350]."

1 Cor. iv. 15.
Isa. lxi. 6.
Heb. v. 4, 5.

REVEREND Father in God, I present unto you these persons present, to be admitted to the Order of Priesthood.

The Bishop.

Ezra vii. 10.
Ps. cxxxii. 9. 16.
Mal. ii. 7.

TAKE heed that the persons, whom ye present unto us, be apt and meet, for their learning and godly conversation, to exercise their Ministry duly, to the honour of God, and the edifying of his Church.

¶ *The Arch-Deacon shall answer,*

IHAVE enquired of them, and also examined them, and think them so to be.

¶ *Then the Bishop shall say unto the people;*

Isa. lxi. 6.
Ps. cxxxii. 9. 16.
Acts xxiv. 16.
1 Tim. iii. 7.

GOOD people, these are they whom we purpose, God willing, to receive this day unto the holy Office of Priesthood: For after due examination we find not to the contrary, but that they be lawfully called to their Func-

tion and Ministry, and that they be persons meet for the same. But yet if there be any of you, who knoweth any Impediment, or notable Crime, in any of them, for the which he ought not to be received into this holy Ministry, let him come forth in the Name of God, and shew what the Crime or Impediment is.

¶ *And if any great Crime or Impediment be objected, the Bishop shall surcease from Ordering that person, until such time as the party accused shall be found clear of that Crime.*

¶ *Then the Bishop (commending such as shall be found meet to be Ordered to the Prayers of the congregation) shall, with the Clergy and people present, sing or say the Litany, with the Prayers, as is before appointed in the Form of Ordering Deacons; save only, that, in the proper Suffrages there added, the word [Deacons] shall be omitted, and the word [Priests] inserted instead of it.*

¶ *Then shall be sung or said the Service for the Communion, with the Collect, Epistle, and Gospel, as followeth.*

OREMUS, dilectissimi, Deum Patrem omnipotentem, ut super hos famulos suos, quos ad presbyterii munus elegit, cœlestia dona multiplicet, et quod ejus dignatione suscipiunt, ipsius consequantur auxilio. Salisbury Use.

Then the Bishop shall say] Martene [ii. 122] cites the following: "Allocutio ad populum ad ordinandum Presbyterum: Quoniam, dilectissimi fratres, conversatio illius, quantum noscere mihi videor, probata ac Deo placita est, et digna, ut arbitror, ecclesiastici honoris augmento quid de ejus actibus aut moribus noveritis, quid de merito censeatis, Deo teste, consulimus. Sed ne unum fortasse vel paucos aut decipiat assensio aut fallat affectio, sententia expectanda est multorum." [Pont. Noyon., A.D. 800.] "Si quis autem habeat aliquid contra hos viros, pro Deo et propter Deum cum fiducia exeat et dicat." [Pont. S. Corn., ante A.D. 600.]

In the Harl. MS. 2906, fo. 11, is this Allocutio ad populum: "Fratres, rectori navis et navigio deferendis eadem est vel securitatis ratio vel timoris. Communis eorum debet esse sententia quorum causa communis existit. Nec frustra a patribus reminiscimur institutum ut de electione eorum qui ad regimen altaris adhibendi sunt consulatur et populus. Quia de actu et conversatione presentandi quod nonnunquam ignoratur a pluribus scitur a paucis; et necesse est ut facilius quos obedientiam exhibeat ordinato cui assensum præbuerit ordinando. Fratrum nostrorum et Presbyterorum illorum conversatio quantum mihi videtur probata et Deo placita est, et digna, ut arbitror, ecclesiastici honoris augmento. Sed ne unum fortasse vel paucos aut decipiat aut fallat affectio, sententia est expectanda multorum. Itaque quid de eorum actibus aut moribus noveritis, quid de merito censeatis, Deo Teste, consulimus. Debet hanc fidem caritas vestra habere quam secundum præceptum evangelicum et Deo exhibere debetis et proximo, ut his testimonium sacerdotii magis pro merito quam

affectione aliqua tribuatis, et qui devotione omnium expectamus intelligere tacentes non possumus. Scimus tamen quid est acceptabilis Deo. Aderit per Spiritum Sanctum consensus unus animorum, et ideo electionem vestram debetis publica voce profiteri."

The appeal to the testimony of the people at the ordination of Priests is alluded to by Lampridius, in the life of Alexander Severus; by St. Leo [Ep. lxxxviii.], who says: "Ut Sacerdos Ecclesiæ præfuturus non solum attestacione fidelium sed etiam eorum qui foris sunt testimonio muniatur;" and by St. Cyprian [Ep. xxxiii.], who says, that in Ordination, he was wont to consult beforehand with the brethren, and weigh the merits and manners of each with common counsel. [Comp. Ep. lxxviii., and St. Basil, Ep. clxxxi.] The edict of Theophylact, patriarch of Constantinople [Can. vi.], required Ordinations to be held "ἐν μέσῳ τῇ ἐκκλησίᾳ, παρόντος τοῦ λαοῦ καὶ προσφωνούντος τοῦ ἐπισκόπου εἰ καὶ ὁ λαὸς δύναται αὐτῷ μαρτυρεῖν;" and by the III. Council of Carthage [c. xxii.] no Clerk was to be ordained without examination by the Bishop and the witness of the people.

the Litany] No Litany was appointed in the Pontifical of Rheims. It first occurs in the Sacramentary of Pope Gregory. In the Greek Euchologium these petitions occur:—

ἵπὲρ τοῦ δὲ τοῦ νυνὶ προχειριζομένου πρεσβυτέρου καὶ τῆς σωτηρίας αὐτοῦ τοῦ Κυρίου δεηθῶμεν.

ὁπως ὁ φιλόανθρωπος ΘΕΟΣ ἄσπιλον καὶ ἀμάμητον αὐτοῦ τὴν ἱερωσύνην χαρίζεται δεηθῶμεν. [Assemani, P. iv. p. 109.]

the Service for the Communion] The Rubric of 1549 directed: "When the Exhortation is ended, then shall be sung for the

The Collect.

James i. 17

ALMIGHTY God, giver of all good things, who by thy Holy Spirit hast appointed divers Orders of Ministers in the Church; Mercifully behold these thy servants now called to the Office of Priesthood; and replenish them so with the truth of thy doctrine, and adorn them with innocency of life, that, both by word and good example, they may faithfully serve thee in this Office, to the glory of thy Name, and the edification of thy Church; through the merits of our Saviour Jesus Christ, who liveth and reigneth with thee and the Holy Ghost, world without end. *Amen.*

The Epistle.

Ephesians iv. 7 [—13].

* * * * *

¶ *After this shall be read for the Gospel part of the ninth Chapter of Saint Matthew, as followeth.*

St. Matt. ix. 36 [—38].

* * * * *

¶ *Or else this that followeth, out of the tenth Chapter of Saint John.*

St. John x. 1 [—16].

* * * * *

¶ *Then the Bishop, sitting in his chair, shall minister unto every one of them the Oath concerning the Queen's Supremacy, as it is before set forth in the Form for the Ordering of Deacons.*

¶ *And that done, he shall say unto them as hereafter followeth.*

John xiii. 17.
1 Cor. iv. 1.
2 Cor. v. 18—20.

YOU have heard, Brethren, as well in your private examination, as in the exhortation which was now

DEUS, sanctificationum omnium auctor, cujus vera consecratio plenaque benedictio est, Tu, Domine, super hos famulos tuos, quos presbyterii honore dedicamus, munus tuæ benedictionis effunde: ut gravitate actuum et censura vivendi probent se esse seniores, his instituti disciplinis quas Tito et Timotheo Paulus exposuit, ut, in lege tua die ac nocte meditantes, quod legerint credant, quod crediderint doceant, quod docuerint imitentur; justitiam, constantiam, misericordiam, fortitudinem, ceterasque virtutes in se ostendant, exemplo probent, admonitione confirment, ac purum et immaculatum ministerii sui donum custodiant]

[Salisbury Use.
Gregor.]

Introit to the Communion this Psalm: 'Expectans expectavi Dominum' [Ps. xl.]; or else this Psalm: 'Memento, Domine, David' [Ps. cxxii.]; or else this Psalm: 'Laudate nomen Domini' [Ps. cxxxv.]" These were some of the Psalms recommended to be said secretly by the Elect Bishop in old forms, whilst the congregation were praying for him.

The Collect This Collect corresponds to the Consecratio of the Pontificals, and, in its opening, to the Benedictio, the reading "all good things" being a translation of a corrupt reading, "honorum," noticed by the ritualists, for "honorum," which denoted ecclesiastical orders. In the Pontificals of Egbert and Dunstan, this Prayer is entitled "Consummatio Presbyteri." In the Greek Euchologium this Prayer occurs: Τέλειον ἀνάδειξον δοῦλόν σου ἐν πᾶσι, εὐαρεστοῦντά σοι καὶ ἀξίως πολιτευόμενον τῆς δωρισθείσης προορωστικῆς δυνάμεως μεγάλης ταύτης ἱερατικῆς τιμῆς. [Assemanni, Cod. Lit. tom. xi. p. 109.]

The Epistle and Gospel "In Ordinatione Presbyterorum: Lectio Libri Sapientiæ, 'Sacrificium salutare est attendere mandatis;' Sequentia, S. Evangelii secundum Matthæum, 'Vigilate ergo quia nescitis.'" [D. Hieron. Comes ap. Pamelium, ii. 60.] The Gallican Church read for the Epistle, Titus i. 1—6. The Gospel St. John x. 1 was read in that Church in Natali Episcoporum [Mabillon, lib. ii. No. lxxviii., lxxi.]. The Natalis of a Bishop was the commemoration of the day of his consecration [ap. Migne, lxxiv. 206]. In the German Liturgy, the Gospel was St. Matthew: "In illo tempore dixit Jesus . . . constituet eum;" or St. John: "In illo tempore loquente Jesu . . . opera Abraham facito." [Gerbert, 444.]

You have heard, brethren, &c. In a French Pontifical of the sixth century, there is an Exhortation to the people at the Consecration of a Bishop which resembles this address in spirit: "In locum defuncti talis successor præparatur Ecclesiæ, cujus

2 Cor. ii. 15, 16.
iii. 5. iv. 7.
viii. 23.
2 Tim. iv. 5.
Luke xii. 42, 43.
xix. 10.
2 Tim. ii. 2.
Acts xx. 31. 28.
1 Pet. ii. 25.
John xvii. 15.

made to you, and in the holy Lessons taken out of the Gospel, and the writings of the Apostles, of what dignity, and of how great importance this Office is, wherunto ye are called. And now again we exhort you, in the Name of our Lord Jesus Christ, that you have in remembrance, into how high a Dignity, and to how weighty an Office and Charge ye are called: that is to say, to be Messengers, Watchmen, and Stewards of the Lord; to teach, and to premonish, to feed and provide for the Lord's family; to seek for Christ's sheep that are dispersed abroad, and for his children who are in the midst of this naughty world, that they may be saved through Christ for ever.

2 Tim. i. 6.
2 Cor. iv. 7.
John x. 10, 11.
14, 15.
Matt. xx. 28.
2 Cor. xi. 2.
Eph. v. 23—27.
30—32.
Luke xii. 45—48.
Ezek. xxxiv. 2—
10. xxxiii. 7, 8.
Jer. xxiii. 1, 2.
11, 12.
2 Cor. vi. 20. 18.
Eph. iv. 11—13.
Heb. xiii. 17.
1 Tim. i. 18, 19.
iv. 13—16.
2 Tim. ii. 15. 25.
iv. 2.
Heb. vi. 1.
Eph. iv. 3—6.
13, 14.
Col. i. 28.
Rev. ii. 2, 3.

Have always therefore printed in your remembrance, how great a treasure is committed to your charge. For they are the sheep of Christ, which he bought with his death, and for whom he shed his blood. The Church and Congregation whom you must serve, is his Spouse, and his Body. And if it shall happen the same Church, or any Member thereof, to take any hurt or hindrance by reason of your negligence, ye know the greatness of the fault, and also the horrible punishment that will ensue. Wherefore consider with yourselves the end of your Ministry towards the children of God, to-

wards the Spouse and Body of Christ; and see that you never cease your labour, your care and diligence, until you have done all that lieth in you, according to your bounden duty, to bring all such as are or shall be committed to your charge, unto that agreement in the faith and knowledge of God, and to that ripeness and perfectness of age in Christ, that there be no place left among you, either for error in religion, or for viciousness in life.

Forasmuch then as your Office is both of so great excellency, and of so great difficulty, ye see with how great care and study ye ought to apply yourselves, as well that ye may shew yourselves dutiful and thankful unto that Lord who hath placed you in so high a Dignity, as also to beware, that neither you yourselves offend, nor be occasion that others offend. Howbeit, ye cannot have a mind and will thereto of yourselves; for that will and ability is given of God alone: therefore ye ought, and have need, to pray earnestly for his holy Spirit. And seeing that you cannot by any other means compass the doing of so weighty a work, pertaining to the salvation of man, but with doctrine and exhortation taken out of the holy Scriptures, and with a life agreeable to the same; consider how studious ye ought to be in reading and learning the Scriptures,

Rom. xi. 13.
1 Cor. iii. 9—15.
2 Cor. ii. 14—16.
iv. 1—7. 11.
v. 20.
1 Tim. i. 12.
1 Cor. ix. 26, 27.
viii. 9. 11. 13.
2 Cor. iii. 5, 6.
Phil. ii. 13.
John xv. 4.
Luke xi. 13.
John xvi. 23, 24.
1 Cor. iii. 7.
Luke vi. 39.
Matt. v. 13.
1 Tim. iv. 13. 16.
2 Tim. iii. 14—17.
Matt. xiii. 52.
2 Tim. ii. 22. 24.
25.
Tit. ii. 7.
1 Tim. iii. 2—6.
Deut. vi. 6, 7.
Luke v. 10, 11.
viii. 14.
Matt. vi. 24.
2 Tim. ii. 3, 4. 10.

pervigili cura et instanti sollicitudine ordo Ecclesiae et credentium fides in Dei timore melius convalescat. Qui praecipienti Apostolo in omni doctrina formam boni operis ipse praebet, cuique habitus, sermo, vultus, incessus, doctrina, virtus sit. Qui ut pastor bonus fide instruat, exemplum patientiae doceat, doctrinam religionis instituat, in omni bono opere confirmet caritatis exemplum Sit in [populo] quasi unus ex illis, omnia iudicii Domini nostri, non pro se tantum sed et pro omni populo qui sollicitudini suae creditur, contremiscens, ut qui meminerit de speculatorum manibus omnium animas requirendas, pro omnium salute pervigilet, pastoralis ergo creditas sibi oves Domini diligentiae ejus semper se flagrantissimum adprobans." [Morin, p. 265.]

Compare also with the earlier portion of the Exhortation, the following:—"Eja dilectissime frater, satage atque elaborare non desinas ad perficiendum opus quod inchoaturus es, ut oves tibi traditas tandem aliquando ad ovile Dominicum salubre et refectionis pabulo educatas representari te una cum eis merearis. Imploranda est et cum gemitibus crebrisque suspiriis Domini misericordia exoranda, ut opem ferat, quateenus oves quas vobis ad regendum tradidit, juxta Ipsius voluntatem in procella hujus saeculi regere possimus, atque ad ovile Ipsius vitam rectam instituantur, quae via recta est una nobiscum, perducere valeamus. Si pastores ovium semetipsos labore inficiunt ut oves dominorum

suorum absque damno custodiant, quid nos e contra in die districti iudicii dicturi sumus, quando apparuerit Pastor pastorum, Judexque virorum, et coeperit rationem ponere cum servis Suis de talentis quae tradidit?" [Exhort. ad Episc. Cons., Pont. Bisunt., ad ann. circ. dc., Martene, ii. pp. 166—168.]

to bring all such, &c.] Compare the concluding portion of the "Consecratio" in the Sarum Pont. [see also Pont. Egb. p. 23], "et per obsequium plebis tuae . . . et inviolabili caritate, in virum perfectum, in mensuram aetatis plenitudinis Christi in die justitiae et aeterni iudicii, conscientia pura, fide plena, Spiritu Sancto pleni persolvant."

Forasmuch then as your Office, &c.] The hint for this may have been taken from the opening clause of a short admonition in the Sarum Pontifical, addressed by the Bishop to the newly ordained Priests, immediately after the final benediction: "Quia res quam tractaturi estis satis periculosa est, fratres carissimi, moneo ut diligenter et honeste," &c.

as also to beware, &c.] "Cavere debent Presbyteri ne verbum Dei quod annunciant pravis actibus vel moribus corrumpant." [Serm. ad Presb., Martene, ii. p. 51.]

And seeing that you cannot.] "Praedicationi insta, verbum Dei plebi tibi commissae affluenter mellifluoque atque distincte praedicare non desinas. Scripturas Divinas lege, immo si potest

and in framing the manners both of yourselves, and of them that specially pertain unto you, according to the rule of the same Scriptures: and for this self-same cause, how ye ought to forsake and set aside (as much as your may) all worldly cares and studies.

We have good hope that you have well weighed and pondered these things with yourselves long before this time; and that you have clearly determined, by God's grace, to give yourselves wholly to this Office, whereunto it hath pleased God to call you: so that, as much as lieth in you, you will apply yourselves wholly to this one thing, and draw all your cares and studies this way; and that you will continually pray to God the Father, by the Mediation of our only Saviour Jesus Christ, for the heavenly assistance of the Holy Ghost; that, by daily reading and weighing of the Scriptures, ye may wax riper and stronger in your Ministry; and that ye may so endeavour yourselves, from time to time, to sanctify the lives of you and yours, and to fashion them after the Rule and Doctrine of Christ, that ye may be wholesome and godly examples and patterns for the people to follow.

And now, that this present Congregation of Christ here assembled may also understand your minds and wills in these things, and that this your promise may the more move you to do your duties, ye shall answer plainly to these things, which we, in the Name of God, and of His Church, shall demand of you touching the same.

1 Tim. iv. 12.
Col. ii. 6-8.
1 Pet. i. 13-15.

fieri, lectio sancta in manibus tuis, maxime in pectore semper inhæreat, ipsam vero lectionem oratio interrumpat." [Pontif. ap. Martene, l. ii. 166-168.]

that, by daily reading, &c.] Compare the following clauses in the "Consecratio" of the Salisbury Pontifical: "Ut in lege Tua die ac nocte meditantur, quod legerint credant, quod crediderint doceant, quod docuerint imitentur; justitiam, constantiam, misericordiam, fortitudinem, cæterasque virtutes in se ostendant, exemplo probent, admonitione confirmant, ac purum et immaculatum ministerii sui donum custodiant." [See also Pont. Egb. p. 23. MS. Pont. Harl. 2906, fo. 13. MS. Pont. Claud. A. iii. 47, b.]

Do you think, &c.] A short examination is cited by Martene, from a Pontifical "ad usum Ecclesiæ Suessionensis:—

"Vis Presbyterii gradum in nomine Domini acciperes? R. Volo.

"Vis in eodem gradu quantum pravales et intelligis secundum Canonum sanctiones jugiter manere? R. Volo.

DO you think in your heart, that you be truly called, according to the will of our Lord Jesus Christ, and the order of this Church of *England*, to the Order and Ministry of Priesthood?

Answer.

I think it.

The Bishop.

ARE you persuaded that the holy Scriptures contain sufficiently all Doctrine required of necessity for eternal salvation through faith in Jesus Christ? and are you determined out of the said Scriptures to instruct the people committed to your charge, and to teach nothing, as required of necessity to eternal salvation, but that which you shall be persuaded may be concluded and proved by the Scripture?

Answer.

I am so persuaded, and have so determined by God's grace.

The Bishop.

WILL you then give your faithful diligence always so to minister the Doctrine and Sacraments, and the Discipline of Christ, as the Lord hath commanded, and as this Church and Realm hath received the same, according to the Commandments of God; so that you may teach the people committed to your Cure and Charge with all diligence to keep and observe the same?

Answer.

I will so do, by the help of the Lord.

1 Tim. iii. 10.
i. 12.

2 Tim. iii. 15-17.
John xx. 31.
v. 39.
Deut. iv. 2.
xii. 32.
1 Cor. ii. 1. 2.
Rev. xxii. 18, 19.

Ps. cxix. 15, 16.
97.

Col. iv. 17.
1 Tim. i. 3.
Rom. xii. 6-8.
1 Pet. v. 2.
Matt. xxviii. 20.

"Vis Episcopo ad ejus parochiam ordinandus es obediens et consentiens esse, secundum justitiam et ministerium tuum? R. Volo." [Martene, Pont. Succ. A.D. 600, tom. ii. Ord. vii. c. 140, E.]

in your heart] That is, as if from his experience in the diaconate.

Are you persuaded] This question includes the fourth in the Ordering of Deacons, and differs from the third in this respect, that the Priest has to interpret the Holy Scriptures, whilst the Deacon requires a licence to preach. In the Roman Pontifical, the candidates for Priesthood repeat the Creed, "stantes profitentur Fidem quam prædicaturî sunt."

Will you then give, &c.] This and the question following it resemble the Fifth Question in the Ordering of Deacons. An illustration of them occurs in the following Canon:—"Placuit, ut omnes Sacerdotes qui Catholicæ Fidei unitate complectimur nihil ultra diversum aut dissonum in ecclesiasticis Sacramentis aga-

The Bishop.

Matt. vii. 15. 20.
Acts xx. 29.
2 Tim. ii. 17. 23.
25, 26. iii. 6, 7.
13.
1 Thess. v. 14.
James v. 14.
1 Tim. vi. 3—5.
20, 21.
Luke x. 16.

WILL you be ready, with all faithful diligence, to banish and drive away all erroneous and strange doctrines contrary to God's word; and to use both publick and private monitions and exhortations, as well to the sick as to the whole, within your Cures, as need shall require, and occasion shall be given?

Answer.

I will, the Lord being my helper.

The Bishop.

Acts vi. 4.
Eph. vi. 18.
Col. iv. 12.
1 Cor. ix. 16.
1 Tim. iv. 13—16.
1 Cor. ii. 1, 2.
Phil. iii. 7, 8.

WILL you be diligent in Prayers, and in reading of the holy Scriptures, and in such studies as help to the knowledge of the same, laying aside the study of the world and the flesh?

Answer.

I will endeavour myself so to do, the Lord being my helper.

The Bishop.

1 Tim. iii. 8—13.
iv. 12—16.
Ps. cxix. 9.
1 Pet. v. 23.

WILL you be diligent to frame and fashion your own selves, and your families, according to the Doctrine of Christ; and to make both yourselves and them, as much as in

you lieth, wholesome examples and patterns to the flock of Christ?

Answer.

I will apply myself thereto, the Lord being my helper.

The Bishop.

WILL you maintain and set forwards as much as lieth in you, quietness, peace, and love, among all Christian people, and especially among them that are or shall be committed to your charge?

2 Tim. ii. 22.
Matt. v. 9.
1 Pet. iii. 4.
1 Thess. iii. 12, 13.
Luke ii. 14.

Answer.

I will so do, the Lord being my helper.

The Bishop.

WILL you reverently obey your Ordinary, and other chief Ministers, unto whom is committed the charge and government over you; following with a glad mind and will their godly admonitions, and submitting yourselves to their godly judgments?

Heb. xiii. 17.
1 Pet. ii. 13.
v. 5.
Rom. xiii. 5.
1 Cor. xiv. 33.

Answer.

I will so do, the Lord being my helper.

¶ *Then shall the Bishop, standing up, say,*

Phil. ii. 13.
2 Cor. iii. 5.
Matt. xxviii. 20.
Phil. i. 6. 9—11.
Matt. xiii. 12.

ALmighty God, who hath given you this will to do all these things: Grant also unto you strength and power to perform the same; that he may accomplish his work which he hath begun in you; through Jesus Christ our Lord. *Amen.*

¶ *Sequitur præfatio sacerdotum, cum nota, Salisbury Use. stando.*

OREMUS, dilectissimi, Deum Patrem omnipotentem ut super hos famulos suos, quos ad presbyterii munus elegit, cœlestia dona multiplicet, et quod ejus dignatione suscipiunt, ipsius consequantur auxilio.

mus. Unus igitur ordo orandi atque psallendi nobis per omnem Hispaniam atque Galliam conservetur, unus modus in Missarum solemnitatibus, unus in Vespertinis Matutinisque officiis." [Conc. Tolet. IV., A.D. 633, c. 2. Labbe, tom. vi. col. 1450, B.]

Will you be diligent to frame, &c.] Priests and Deacons were required "professionem Episcopo suo facere ut caste ac pure vivant sub Dei timore ut dum eos talis professio obligaverit, vitæ sanctæ disciplinam retineant." [IV. Conc. Tolet., c. xxvii. Labbe, tom. vi. col. 1460, A.] By the Canons of the African Church [B. xiii. c. xxxvi.], and the III. Council of Carthage [c. xviii.], Bishops, Priests, and Deacons are not to be ordained until they have made every one in their household Catholic Christians [Martene, lib. i. c. viii. art. 2, § 17, tom. ii. col. 15, B, Ed. Rouen, 1700]. In the Legatine Constitutions of Cardinal Pole, Clerks are required "curare ut domesticorum suorum vita honesta et probata sit." [Decr. v., Cardw. Doc. Ann. i. p. 185. Compare Art. XXXII., and Mason de Min. Anglic. l. ii. c. viii.]

Will you reverently, &c.] Ordinaries by Canon Law are those

"quibus competit jurisdictio ordinaria de jure privilegii vel consuetudine." [Lynd. Prov. lib. i. tit. ii.] The Ordinary is (1) the Bishop, in the diocese; (2) the Dean, in the cathedral; (3) the Archdeacon, in the Archdeaconry. The "chief Ministers" are incumbents of parishes. St. Jerome says to Nepotian, "Esto subjectus Pontifici tuo et quasi animæ parentem suscipe" [Ep. xxxiv., Op. tom. iv. c. 261]; and St. Augustine, "Episcopo tuo noli resistere, et quod facit ipse, sine ullo scrupulo vel disceptatione sectare" [Ep. xxxvi. ad Casul., tom. ii. c. 81, E.].

The Council of Toledo decrees (Canon x.), "Placuit huic sancto concilio ——— ut debitum per omnia honorem, atque obsequii reverentiam præminentis sibi unusquisque dependat, juxta illud beati Papæ Leonis edictum: Qui scit se quibusdam esse præpositum, non moleste ferat aliquem sibi esse prælatum, sed obedientiam quam exigit, etiam ipse dependat." [Conc. Mansi, tom. xi. col. 143, ap. Mask. Mon. Rit. iii. 222.]

Almighty God] After the short examination cited above from Martene follows the prayer:—"Voluntatem tuam bonam et

1 Thess. v. 25. ¶ *After this, the Congregation shall be desired, secretly in their Prayers, to make their humble supplications to God for all these things: for the which Prayers there shall be silence kept for a space.*

Acts ii. 3, 4.
2 Cor. iv. 6.
Acts x. 38.
Rev. i. 4. iii. 1.
1 John ii. 20. 27.
John xiv. 26.
Isa. lx. 19.
Luke xxiv. 25—27.
Ezek. xxxvi. 25—27.
1 Tim. i. 14.
Ps. lxxviii. 1, 2.
cxxxii. 6, 7.
lxxviii. 24.
John xvii. 3.
xv. 26.
Rev. v. 12, 13.
iv. 8.

¶ *After which shall be sung or said by the Bishop (the persons to be Ordained Priests all kneeling) Veni, Creator Spiritus; the Bishop beginning, and the Priests, and others that are present, answering by verses, as followeth.*

COME, Holy Ghost, our souls inspire,

And lighten with celestial fire.

Thou the anointing Spirit art,

Who dost thy seven-fold gifts impart.

Thy blessed Unction from above,

Is comfort, life, and fire of love.

Enable with perpetual light

The dulness of our blinded sight.

Anoint and cheer our soiled face

With the abundance of thy grace.

Keep far our foes, give peace at home;

Where thou art guide, no ill can come.

Teach us to know the Father, Son,

And thee, of both, to be but one.

That, through the ages all along,

This may be our endless song;

Praise to thy eternal merit,

Father, Son, and Holy Spirit.

¶ *Expleta autem hac oratione (i. e. the "Con- Sa'isbury Use. secratio") genuflectendo coram altare incipiat Episcopus hymnum.*

VENI, Creator Spiritus,
Mentes tuorum visita:

Imple superna gratia

Quæ tu creasti pectora.

Qui Paraclitus diceris,

Donum Dei altissimi:

Fons vivus, ignis, caritas,

Et spiritalis unctio.

Tu septiformis munere,

Dextræ Dei tu digitus:

Tu rite promissum Patris,

Sermone ditans guttura.

Accende lumen sensibus,

Infunde amorem cordibus:

Infirma nostri corporis

Virtute firmans perpetim.

Hostem repellas longius,

Pacemque dones protinus:

Ductore sic te prævio

Vitemus omne noxium.

Per te sciamus da Patrem,

Noscamus atque Filium:

Te utriusque Spiritum

Credamus omni tempore.

Sit laus Patri cum Filio,

Sancto simul Paraclito:

Nobisque mittat Filius

Charisma Sancti Spiritus.

Amen.

Or this,

COME, Holy Ghost, eternal God,
Proceeding from above,
*Both from the Father and the Son,
The God of peace and love.*

Visit our minds, into our hearts
Thy heavenly grace inspire;
*That truth and godliness we may
Pursue with full desire.*

rectam ad perfectionem sibi beneplacitam Deus perducere dignetur." [Martene, Eccl. Rit. ii. 146.]

After which shall be sung] The rubric in Lacy's Pontifical is, "Episcopus cum ministris suis ante altare in medio genuflectat cantando Ymnium, 'Veni Creator Spiritus.' Et chorus prosequatur. Et incipiat Episcopus cum suis ministris quemlibet versum illius ymni et chorus prosequatur."

Come, Holy Ghost] The first version of this hymn was added in 1662: in the earlier Prayer Books the longer translation only was given. This hymn was probably introduced into the service

late in the eleventh century, when it occurs in the Pontifical of Soisson [Martene, Ordo vii., tom. ii. col. 141, C.]. Two centuries later, in the Pontifical of Mayence, there is this rubric, "Episcopus incipiat Clero prosequente 'Veni Creator Spiritus' . . . item chorus cantet sequentiam 'Sancti Spiritus adsit,' etc., et si multitudo ordinandorum requirit, addatur hymnus, 'Veni Creator.'" [Ibid. Ordo xvi. col. 221, B. Assemani, Cod. Liturg. Ordo ii., P. i. p. 308.] It is found in all English Pontificals with the exception of that of Winchester; and in two Pontificals, one printed by Morin [de Sac. Ord. P. ii. p. 281, D., 279, E.], the other by Assemanu

Thou art the very Comforter
 In grief and all distress ;
*The heav'nly gift of God most high,
 No tongue can it express.*

The fountain and the living spring
 Of joy celestial ;
*The fire so bright, the love so sweet,
 The Unction spiritual.*

Thou in thy gifts art manifold,
 By them Christ's Church doth
 stand :
*In faithful hearts thou writ'st thy law,
 The finger of God's hand.*

According to thy promise, Lord,
 Thou givest speech with grace ;
*That through thy help God's praises
 may
 Resound in every place.*

O Holy Ghost, into our minds
 Send down thy heav'nly light ;
*Kindle our hearts with fervent zeal,
 To serve God day and night.*

* Our weakness strengthen and confirm,
 (For, Lord, thou know'st us frail ;)
*That neither devil, world, nor flesh,
 Against us may prevail.*

Put back our enemy far from us,
 And help us to obtain
*Peace in our hearts with God and man,
 (The best, the truest gain ;)*

And grant that thou being, O Lord,
 Our leader and our guide,
*We may escape the snares of sin,
 And never from thee slide.*

Such measures of thy powerful grace
 Grant, Lord, to us, we pray ;
*That thou may'st be our Comforter
 At the last dreadful day.*

Of strife and of dissension
 Dissolve, O Lord, the bands,
*And knit the knots of peace and love
 Throughout all Christian lands.*

Grant us the grace that we may know
 The Father of all might,
*That we of his beloved Son
 May gain the blissful sight,*

And that we may with perfect faith
 Ever acknowledge thee,
*The Spirit of Father, and of Son,
 One God in Persons Three.*

To God the Father laud and praise,
 And to his blessed Son,
*And to the Holy Spirit of grace,
 Co-equal Three in One.*

And pray we, that our only Lord
 Would please his Spirit to send
*On all that shall profess his Name,
 From hence to the world's end.*
Amen.

† *That done, the Bishop shall pray in this wise,
 and say,*

Let us pray.

1 Thess. v. 25.
 Exod. vi. 3.
 Matt. vi. 9.
 John iii. 16.
 1 John iv. 9.
 Eph. i. 7.
 Heb. v. 9.
 John xix. 30.
 Heb. x. 14.

ALMIGHTY God, and heavenly
 Father, who, of thine infinite
 love and goodness towards us, hast
 given to us thy only and most dearly
 beloved Son Jesus Christ, to be our
 Redeemer, and the Author of ever-
 lasting life ; who, after he had made
 perfect our redemption by his death,
 and was ascended into heaven, sent

DOMINE sancte, Pater omnipo- Salisbury Use.
(Sacr. Greg.)
 tens, æterne Deus : honorum
 dator, et distributor omnium dignita-
 tum Unde et sacerdotales
 gradus, atque officia Levitarum, sacra-
 mentis mysticis instituta creverunt,
 ut cum pontifices summos regendis
 populis præfecisses, ad eorum societa-
 tis et operis adjumentum, sequentis

[Codex Liturg. Ordo iv., tom. i. p. 367, Rome 1755], there are the following rubrics :—“ Deinde Episcopo incipiente cantatur hymnus ‘Veni Creator Spiritus.’ ” “ Pontifex flexis genibus incipit alta voce, schola prosequente, ‘Veni Creator Spiritus.’ ” Dean Comber [Discourse &c. chap. vi. § i. p. 341] observes, that the composition of this hymn was ascribed to St. Ambrose. It is not, however, claimed by his Benedictine editors. In the Salisbury Breviary it occurs as a hymn for Pentecost, “ Ad Tertiam.”

Almighty God, and heavenly Father] This Prayer corre-

sponds to the Consecratio of the elder Pontificals. In MS. Harl. 2906, fo. 12, it forms part of the “ Vere dignum et justum est,” as it does also in the Salisbury Pontifical. A very similar Prayer is to be found in the Syro-Nestorian Ordinal : “ Domine Deus fortis et omnipotens, elegisti Ecclesiam Sanctam Tuam, et posuisti in ea Prophetas et Apostolos et Doctores et Sacerdotes ; et in opus ministerii et in edificationem corporis Ecclesiastici. Tu ergo respice etiam nunc in servos Tuos . . . ornet quoque et illustrent operibus justis filios Ecclesie sancte Catholice ad laudem Nominis Tui Sancti.” [Syr. Nest. Ord. P. ii. p. 386.]

Eph. iv. 8. 11—13. abroad into the world his Apostles,
 Rom. x. 13—15. Prophets, Evangelists, Doctors, and
 18. Pastors; by whose labour and minist-
 1 Pet. iv. 11. try he gathered together a great flock
 Ps. cxlv. 10—12. in all the parts of the world, to set
 lii. 1. forth the eternal praise of thy holy
 Matt. xxviii. 19, 20. Name: For these so great benefits
 Acts i. 21, 22, 24. of thy eternal goodness, and for that
 2 Tim. ii. 2. thou hast vouchsafed to call these thy
 Ps. lxxviii. 19. servants here present to the same
 1 John v. 14. Office and Ministry appointed for
 1 Cor. i. 1, 2, 4. the salvation of mankind, we render
 Eph. v. 20. unto thee most hearty thanks, we
 Ps. ciii. 1, 2. praise and worship thee; and we
 Hosea vi. 3. humbly beseech thee, by the same
 2 Pet. iii. 18. thy blessed Son, to grant unto all,
 Phil. iii. 13, 14. which either here or elsewhere call
 8, 9. upon thy holy Name, that we may
 Ps. cxxxv. 19—21. continue to shew ourselves thankful
 cxlix. 1. unto thee for these and all other thy
 xl. 16. benefits; and that we may daily
 Ps. lxxxvi. 9, 12. increase and go forwards in the know-
 Phil. ii. 9—11. ledge and faith of thee and thy Son,
 Rev. xi. 15. by the Holy Spirit. So that as well
 v. 13, 14. as by these thy Ministers, as by them
 over whom they shall be appointed
 thy Ministers, thy holy Name may
 be for ever glorified, and thy blessed
 kingdom enlarged; through the same
 thy Son Jesus Christ our Lord, who
 liveth and reigneth with thee in the
 unity of the same Holy Spirit, world
 without end. *Amen.*

1 Tim. iv. 14.

¶ *When this Prayer is done, the Bishop with the Priests present shall lay their hands severally upon the head of every one that receiveth the Order of Priesthood; the Receivers humbly kneeling upon their knees, and the Bishop saying,*

ordinis viros et secundæ dignitatis eligeres hac providentiâ, Domine, apostolis Filii tui Doctores fidei comites addidisti; quibus illi orbem totum secundis prædicationibus impleverunt

¶ *Benedicente eos Episcopo postea, et manum super capita eorum tenente, et nihil eis dicente, et una manu tangente, et omnes presbyteri qui presentes sunt, manus suas super capita eorum levatas teneant.*

When this Prayer is done, &c. The rubric in the Pontifical of Egbert is, "Et benedicente eum Episcopo, manus super caput ejus teneat. Similiter et presbyteri, qui presentes sunt, manus suas juxta manum Episcopi super caput illius teneant." It occurs also in the Sacramentary of Pope Gregory. In MS. Harl. 2906 [fo. 11], the rubric is, "Eo inclinato imponat manum super caput ejus et omnes Presbyteri qui adsunt cum eo pariter," &c. In the MS. Pontifical of the tenth century, Claud. iii. 45, b., the word "ponant" occurs instead of "teneant." In several French MSS. the word used was "teneant;" in the Ordo Romanus, and an English Pontifical cited by Menard, it is "ponant." In the Roman Pontifical, the Bishop and Priests lay both their hands on the head of the Candidate, after which they hold their right hands extended over them. The 3rd Canon of the IV. Council of Carthage directs: "Presbyter cum ordinatur, Episcopo eum benedicente, et manum super caput ejus tenente, etiam omnes Presbyteri qui presentes sunt, manus suas juxta manum Episcopi super caput illius teneant." [Maskell, Mon. Rit. iii. 205.] The Church of England has now prescribed only one imposition of hands, and confers explicitly in her form the power, [1] of Preach-

ing; [2] of Consecrating the Holy Eucharist; and [3] of Absolution of Penitents. The Greek Church does not give such a commission formally, but uses Invocation of the Holy Ghost, a Prayer of Consecration, a Benediction, and a Prayer that "the Priest may be presented unblameable at the altar of God, to preach the Gospel of His salvation, to minister the Word of His truth, to offer oblations and spiritual sacrifices, and to renew His people by the laver of regeneration." [Græc. Ord. ap. Morin. P. ii. p. 55.] The Commission to consecrate the Holy Eucharist was never given until the tenth century, when this rubric occurs [Morin, P. ii. 262; P. iii. Exerc. vii. c. i. § 16, p. 105]: "Let him take the Paten with the oblation and the Chalice with the wine, and say, 'Receive power to offer sacrifice to God and celebrate Mass.'" In England it appears in the Bangor Pontifical before the close of the thirteenth century [Maskell, Mon. Rit. iii. 213]. Compare the Pontificals of Beauvais, Mayence, Noyon, Besançon, Cambrai, Apamea, given by Morin [pp. 271, 277], and Martene [tom. ii. pp. 138, 174, 192, 197, 221].

the Receivers humbly kneeling] The Candidate kneels because in the presence of the ambassador and representative of

John xx. 21—23.
2 Tim. i. 6, 14, 13.
Exod. xl. 15.
xviii. 18, 20.
23.
Heb. v. 4.
Matt. xvi. 19.
2 Tim. iv. 1, 2.
Matt. xxviii. 19,
20.
1 Cor. xi. 23—25.
Luke xii. 42, 43.
Rev. ii. 10.

RECEIVE the holy Ghost for the Office and Work of a Priest in the Church of God; now committed unto thee by the Imposition of our hands. Whose sins thou dost forgive, they are forgiven; and whose sins thou dost retain, they are retained. And be thou a faithful Dispenser of the Word of God, and of his holy Sacraments; In the Name of the Father, and of the Son, and of the Holy Ghost. Amen.

¶ *Then the Bishop shall deliver to every one of them kneeling, the Bible into his hand, saying,*

Antequam dicatur postcommunio, ponat Episcopus manus suas super capita singulorum, dicens :

ACCIPE Spiritum Sanctum : quorum remiseras peccata, remittuntur eis : et quorum retinueris, retenta erunt.

our Blessed Lord, executing his office in His name, and by His authority; and also, as invoking the confirmation of His servant's words by the Saviour Himself.

Receive the holy Ghost] Archbishop Whitgift says, "Christ used these words: 'This is My Body,' in the celebration of His Supper, but there is no special commandment that the Minister should use the same, and yet must he use them because Christ used them; even so, when Christ did ordain His Apostles Ministers of the Gospel, He said unto them, 'Receive the Holy Ghost,' which words, because they contain the principal duty of a Minister, and do signify that God doth pour His Holy Spirit upon those whom He calleth to that function, are most aptly also used of the Bishop, who is God's instrument in that business in the ordaining of Ministers. St. Paul, speaking to Timothy, saith: 'Neglect not the gift that is in thee, which was given unto thee by prophecy with the laying on of the hands of the Eldership.' In which words the Apostle signifieth that God doth bestow His gifts and Spirit upon such as be called to the Ministry of the Word, whereof Ordination is a token, or rather a confirmation." [Defence, Tr. iv. vol. i. p. 490.] So Calvin, "Unde colligimus non inanem fuisse ritum, quia consecrationem quam homines impositione manuum figurabant, Deus Spiritu Suo inflavit." [Comm. in Epist. i. ad Timoth. c. iv. 14, tom. vii. p. 458.]

All sacerdotal power is derived from the Holy Ghost; the Church, therefore, holds that the reception of the Holy Ghost is necessary to constitute a Christian Priest, and that this gift can be conferred only through the hands of a Bishop. The priesthood is a grace of the Holy Spirit. "The Holy Ghost," says Bishop Cosin, "is then given to them, partly to direct and strengthen them in their ways, and partly to assume unto Itself for the more assurance and authority those actions which belong to their place and calling." [Serm. vi.] Being the very words employed by our Lord when He ordained His Apostles, they are the original Charter of the institution of the Ministry, from which alone the limits and extent of its authority are to be known. In the office of Holy Baptism, the Priest says, acting in the Name and person of Christ: "I baptize thee in the Name," &c. In the Holy Eucharist he repeats the very words of the Lord, and applies them to the sacred elements. In Absolution of the Sick, he says, "By His authority committed to me, I absolve thee;" and in the office of Matrimony, "I pronounce that they be man and wife together in the Name," &c. So here, because He gives a portion of His Spirit to those whom He sends, the Bishop, in His Name, says, "Receive the Holy Ghost;" that is, the enabling gift, the power, the qualifying grace (*χάρις διακονίας*) for the ministration of Divine things. [Eph. iii. 8. 2 Tim. i. 6. Eph. iv. 7. 11, 12.] As St. Cyprian says: "Intelligimus non nisi . . . Dominica ordinatione fundatis licere baptizare et remissam peccatorum dare" [Ep.

lxxiii.]; and St. Jerome: "Acceperunt Apostoli Spiritus Sancti gratiam qua peccata remitterent et baptizarent" [ad Hedib. Ep. cl.]. All the efficacy that there is in the administration of any Ecclesiastical office depends wholly upon the co-operation of the Holy Ghost: "whether we preach, pray, baptize, communicate, condemn, give absolution, or whatsoever, as disposers of God's mysteries, all words, judgments, acts, and deeds are not ours, but the Holy Ghost's" [Hooker, Eccl. Pol. b. v. c. lxxvii. 5. 8]; and the gift is the spirit of power, of love and soberness, the spirit of confirmation, and of ghostly strength.

It will be observed that the form is in the words of Scripture, "Receive ye . . . retained" [John xx. 22, 23]; and the words, "Be thou a faithful dispenser of the Word of God, and of His holy Sacraments," are simply a clearer rendering of "Ministers of Christ, and stewards of the mysteries of God" [1 Cor. iv. 1], being equivalent expressions denoting the Priest to be invested with the whole ministry of the Gospel committed unto him, the Word of God and His holy Sacraments forming wholly the mysteries of God. An objection having been made to the ancient form, as not sufficiently distinguishing between a Bishop and a Priest, on the advice of Bps. Gunning and Pearson [Prideaux, Valid. of the Orders, p. 72], the words, "for the office and work of a Priest in the Church of God, now committed to thee by Imposition of our hands," were inserted in the Form.

Whose sins thou dost forgive] The form for conveying the power of Absolution is comparatively modern. The actual words, "Receive the Holy Ghost: whose sins ye remit," &c., are first found in a book belonging to the Cathedral of Mayence, of the thirteenth century [Morin, 279, E.; Martene, ii. 327]. Martene cites the following passage from the life of a Bishop of Cambrai, who lived in the tenth century, where the writer is speaking of that Bishop being ordained Priest, and, among other circumstances, remarks, "Cumque ad manus impositionem pontificalis diceretur novo presbytero, 'Accipe Spiritum Sanctum, quorum remiseras peccata,'" &c. Martene, however, adds most justly, "Verum quid unicum testimonium tot pontificalibus libris opponendum." [Martene, tom. ii. 23.] It appears in the Bangor MS. of the thirteenth century, and in a Pontifical of Rouen of the fourteenth century [Morin, P. iii. Exerc. vii. cap. ii. § 2, p. 107, A.]. It is not in the early English MSS. of Egbert or Dunstan, or the Winchester Use; it is not in any of the foreign orders printed by Martene before the twelfth century; it is not in the old Sacramentaries of St. Gregory or Gelasius; nor, lastly, does one of the ancient ritualists, Isidore, Amalarius, Strabo, Aleuin, Micrologus, or Ivo Carnotensis, allude to it in the most distant terms [Maskell, Mon. Rit. iii. 220].

the Bible into his hand] In 1549, the chalice also was directed to be delivered to the Priest by the Bishop, thus

1 Cor. iv. 1, 2.
2 Cor. x. 13-16.
Tit. ii. 15.

TAKE thou Authority to preach the Word of God, and to minister the holy Sacraments in the Congregation, where thou shalt be lawfully appointed thereunto.

¶ *When this is done, the Nicene Creed shall be sung or said; and the Bishop shall after that go on in the Service of the Communion, which all they that receive Orders shall take together, and remain in the same place where hands were laid upon them, until such time as they have received the Communion.*

¶ *The Communion being done, after the last Collect, and immediately before the Benediction, shall be said these Collects.*

Ps. xxiv. 3-5.
cxix. 8.
Ps. cxxxii. 9.
1 Sam. iii. 19.
Isa. iv. 10, 11.
Matt. x. 20.
2 Thess. iii. 1.
Luke viii. 11, 15.
1 Pet. i. 23, 25.
1 Thess. ii. 13.
Matt. v. 16.

MOST merciful Father, we beseech thee to send upon these thy servants thy heavenly blessing; that they may be clothed with righteousness, and that thy Word spoken by their mouths may have such success, that it may never be spoken in vain. Grant also, that we may have grace to hear and receive what they shall deliver out of thy most holy Word, or agreeable to the same, as the means of our salvation; that in all our words and deeds we may seek thy glory, and the increase of thy kingdom; through Jesus Christ our Lord. *Amen.*

PREVENT us, O Lord, in all our doings, with thy most gracious favour, and further us with thy continual help; that in all our works begun, continued, and ended in thee,

ACCIPE potestatem offerre sacrificium Deo, missamque celebrare tam pro vivis quam pro defunctis. Salisbury Use.

¶ *Tunc vertat Episcopus, et dicat offertorium . . . Dum cantatur offertorium, ponantur tot hostiæ quot sufficiant presbyteris ordinandis ad communicandum.*

Post communionem Episcopi, Sacerdotes accedant ad communicandum.

BENEDICTIO Dei Patris✠, et Filii✠, et Spiritus ✠ Sancti, descendat super vos, ut sitis benedicti in ordine sacerdotali, &c.

following the rubric in the Salisbury Use, which directed, "Quo facto, accipiat patenam cum oblatiis et calicem cum vino, et det singulis, inter indices et medios digitos, cuppam calicis cum patena," &c. This rite of delivery of the sacred vessels was quite justifiably abandoned, for it had no prescription in antiquity, as Menard shows [Migne, lxxviii. 493]. It is not mentioned by Dionysius, or the Apostolical Constitutions, in the Pontificals of Rheims, St. Eloy, and others of ancient date, nor by the IV. Council of Carthage, or IV. Council of Toledo, nor by the early fathers, or ritualists, such as Isidore, Rabanus, &c.

in the Congregation] In the Prayer Books of 1549, 1552, it is *this* Congregation. The change to "*the*" is important. The commission, hitherto, was limited to the single diocese in which the Priest was ordained, but now was made general throughout the Church, in whatsoever part he was lawfully called to minister.

The words, "In the Church and Congregation whom you must serve," have just been used in the exhortation as synonymous, just as in the XXIV. Article, where in the title, "the Congregation," and in the body of it, "the Church," is used. In the early translations of the Bible, the word ἐκκλησία, now translated "Church," appears as "Congregation" [Matt. xvi. 18. Acts ii. 47; vii. 3; xii. 1. Eph. i. 22, 23], and in the Bishops' Bible, published in 1568, six years after the date of the Articles, although

"the Church" is the general translation, yet, in the words of the Saviour to St. Peter, the passage is turned, "On this rock I will build My Congregation;" in 1603, the word also appears, "the whole Congregation of Christian people" dispersed throughout the world." In the Latin version of the Articles XIX. XXIII. XXIV. "Congregation" is rendered by "Ecclesia." Dr. Reynolds in 1662 took exception to the words "in the Congregation," as implying that any man without lawful calling might preach and administer Sacraments out of the Congregation, but the Bishops replied, that, by the doctrine and practice of the Church of England none but a licensed Minister might preach, nor either publicly or privately administer the Eucharist [Cardw. Doc. Ann. No. cii. § 2]. Probably the word Congregation was used to avoid misapprehension, owing to the popular but mischievous appropriation of the word Church to designate the Clergy [Twysden's Answ., p. 13], or its application in the sense of an assembly or place of assembly [Fulke's Defence, ch. iv. § 2].

Most merciful Father] This prayer corresponds to the Consummatio of the elder Pontificals, and the Benedictio of the Harl. MS. 2906, fo. 13. To the Benedictio in the Exeter Pontifical this rubric is added:—"Et moneantur attentè audire."

we may glorify thy holy Name, and finally by thy mercy obtain everlasting life; through Jesus Christ our Lord. *Amen.*

THE peace of God, which passeth all understanding, keep your hearts and minds in the knowledge and love of God, and of his Son Jesus Christ our Lord: And the blessing of God Almighty, the Father, the Son, and the Holy Ghost, be amongst you, and remain with you always. *Amen.*

BENEDICTIO Dei omnipotentis, Salisbury Use.
 Patris ✠ et Filii ✠ et Spiritus
 ✠ Sancti, descendat super vos et
 maneat semper. *Amen.*

¶ *And if on the same day the Order of Deacons be given to some, and the Order of Priesthood to others; the Deacons shall be first presented, and then the Priests; and it shall suffice that the Litaney be once said for both. The Collects shall both be used; first, that for Deacons, then that for Priests. The Epistle shall be Ephes. iv, 7—13, as before in this Office. Immediately after which, they that are to be made Deacons shall take the Oath of Supremacy, be examined, and Ordained, as is above prescribed. Then one of them having read the Gospel (which shall be either out of S. Matt. ix. 36—38, as before in this Office; or else S. Luke xii, 35—38, as before in the Form for the Ordering of Deacons,) they that are to be made Priests shall likewise take the Oath of Supremacy, be examined, and Ordained, as is in this Office before appointed.*

And if on the same day] Lacy's Pontifical (p. 84), has the following rubric:—"Aliqui prælati faciunt simul vocare eos qui ordinandi sunt Diaconi et Sacerdotes, quibus sigillatim vocatis et introductis, Episcopus cum ministris prosternat se ante altare

dum Letania a choro cantatur. Aliqui vero dicunt Letaniam solum in ordinatione Presbyterorum. Finita Letania redempt Sacerdotes electi ad loca sua, remanentibus Levitis ad consecrandum."

THE FORM OF
ORDAINING OR CONSECRATING
OF AN
ARCH-BISHOP, OR BISHOP;

Which is always to be performed upon some Sunday
or Holy-day.

¶ *When all things are duly prepared in the Church, and set in Order, after Morning Prayer is ended, the Arch-Bishop (or some*

INCIPIT
CONSECRATIO ELECTI
IN
EPISCOPUM,

Quæ est agenda die Dominica, et non in alia festi-
tate, antequam missa celebretur.

other Bishop appointed) shall begin the Communion Service; in which this shall be

The form of Ordaining, &c.] The distinction of the Order of Bishops from that of Priests was definitely asserted for the first time in 1661, by the addition of the words in the Preface to the Ordinal, "Episcopal Consecration, or Ordination," and "every man which is to be ordained or consecrated a Bishop;" and in the heading, "form of ordaining or consecrating a Bishop," although previously implied in the Preface, which speaks of "these Orders of Ministers in Christ's Church, Bishops, Priests, and Deacons." It was not until the close of the sixteenth century that the distinction between the Orders of Bishops and Priests was asserted. On February 9th, 1589, Dr. Bancroft, in a sermon, maintained the superiority of Bishops *jure divino*; the doctrine was completely acknowledged during the primacy of Laud, and enforced by Bishop Hall in a well-known treatise on the subject. Many writers have held that although the Episcopate is distinguished from the Presbyterate *jure divino*, yet they together form but one order, because both hold the administration of the Word of God and Sacraments, and have the common trust of the power of the keys, and the Episcopate includes within it the Priesthood of the second degree, being its extension, consummation, and completion, i. e. being the highest Priesthood. Epiphanius condemned Acrius for asserting the identity of the orders [Hær. lxxv. Comp. St. August. de Hær. c. liiii.]. St. Jerome says: "In Episcopo et Presbyter continetur." [Ep. cii. ad Evang. tom. iv. c. 803.] St. Ambrose, or rather Hilary the Deacon, observes: "In Episcopo omnes ordines sunt; quia primus sacerdos est, hoc est, princeps est sacerdotum." [In Ephes. c. iv. 11, tom. ii. col. 241, D. App.]. "Episcopi et Presbyteri una ordinatio est. Uterque enim sacerdos est." [In 1 Ep. ad Timoth. c. iii. 10, col. 295, Ed. Par. 1690.] Anicetus, in the same sense, called the Priesthood "bipartitus ordo" [Ep. iii. § 1; Labbe, tom. i. c. 529, c.]; and so do Ælfric's Canons, A.D. 1052, § xvii.; Spelman's Conc. p. 576; Theodulf's Capitulars, A.D. 791, c. i.; Labbe, tom. ix. c. 185, A.; and our own Reformers, the Bishop of St. David's, with doctors Thirleby, Redman, and Coxe, held, that, in the beginning, Bishops and Priests were identical [Burnet's Hist. of Reform. B. iii. v. ii. p. 211], there being, as the Bishops held, no mention in the New Testament, but of two degrees or distinctions in orders, but only of Deacons or Ministers, and of Priests or Bishops [Ib. Add. p. 300]. Thorn-dike admits that the name of Priest [Sacerdos] is common to both estates, as in regard of the offices of Divine Service, which

are performed by both, so, in regard of the government of the Church, common to both [Prim. Gov. of Churches, ch. vii. vol. i. P. i. p. 33. Comp. Bp. Taylor's Episc. Asserted, § 28]. Bellarmine says, "Septimus ordo Sacerdotum est: at Ecclesia Catholica distinctionem agnoscit, ac docet jure divino Episcopatum Presbyterio majorem esse, tum ordinis potestate, tum etiam jurisdictione. Sic enim loquitur Conc. Trident. [Sess. xxiii. c. iv. can. vi. vii.] Eandem sententiam docent et defendunt Theologi doctores apud Magistrum in libro iv. Sent. dist. xxiv., et S. Thom. in ii. 2, qu. clxxxiv. art. vi. de clericis." [Cap. xiv. col. 265, A. C. Colon. 1620.] As Dodwell observes, "Philo sometimes reckons the High Priest in the same order with the common Priests, sometimes he makes him a distinct order by himself." [One Priest, etc., ch. xii. s. vi. p. 348, Lond. 1683.] Fulke timidly says, "The Orders of Bishops, Elders, and, as they be commonly called, Priests and Ministers, is all one in authority of ministering the Word and Sacraments. The degree of Bishops, as they are to be taken for a superior order unto Elders or Priests, is for government and discipline specially committed unto them, not in authority of handling the Word and Sacraments." [Defence, etc., ch. xv. § i. p. 461, Ed. Camb. 1843.] The Anglo-Saxon Church distinctly held that there were three orders [Soames, Hist. p. 271, ed. Lond. 1844. Bp. Lloyd, Anc. Gov. of Brit. Church, ch. iii. § 8. Comp. Becon, Catech. P. vi. p. 319, Ed. Camb. 1844]. So Bishop Jewel says, that the doctrine of the English Church is that there are three orders [Apol. Eccles. Ang. pp. 10, 11, ed. Camb. 1847, comp. pp. 271-274. Def. of Apol. P. ii. p. 271, vol. iii. Camb. 1848]. Isidore calls the Episcopate an order [Etymol. l. vii. c. xii. p. 62, H. col. 1617. Comp. Hallier, de Sac. Ord. P. ii. cap. i. § 1. 14, tom. ii. p. 14], and Estius agrees that it is so truly and properly [l. iv. dist. xxiv. § 28, col. 37, B.]. The distinction between the Episcopate and Priesthood lies in the special function of the former, the power of giving Ordination and administering of Confirmation: the Priest's authority to minister is derived from the Bishop who ordains him thereunto [Bp. Cosin, Sermon. vi. vol. i. p. 100. Hooker, Eccles. Pol. b. vii. c. 6, § 3. Bp. Taylor, Episc. Asserted, § 31, 3. 5. § 37, § 28. Prideaux, Val. of Orders, p. 46, Ed. Lond. 1716]. Besides, the Bishop receives an ordination by laying on of hands of Bishops, in order to receive his consecration to the Episcopate, having already received ordination to the Priesthood by the laying on of hands of a Bishop and Priests [Bp. Pearson, Def. i. vol. i. p. 277].

The Collect.

John xx. 21, 22.
Matt. x. 1. 8.
Acts ii. 4.
John xxi. 15, 16.
Acts xx. 28.
Eph. vi. 18—20.
1 Cor. xii. 7—10.
xiv. 33, 40.
2 Tim. iv. 1—8.
Heb. xiii. 7, 17.
2 Thess. i. 11, 12.
Rev. ii. 10.

ALMIGHTY God, who by thy Son Jesus Christ didst give to thy holy Apostles many excellent gifts, and didst charge them to feed thy flock; Give grace, we beseech thee, to all Bishops, the Pastors of thy Church, that they may diligently preach thy Word, and duly administer the godly Discipline thereof; and grant to the people, that they may obediently follow the same; that all may receive the crown of everlasting glory; through Jesus Christ our Lord.
Amen.

¶ *And another Bishop shall read the Epistle.*

1 Tim. iii. 1 [—6].

* * * * *

¶ *Or this, for the Epistle.*

Acts xx. 17 [—35].

* * * * *

¶ *Then another Bishop shall read the Gospel.*

S. John xxi. 15 [—17].

* * * * *

¶ *Or else this.*

S. John xx. 19 [—23].

* * * * *

¶ *Or this.*

S. Matt. xxviii. 18 [—20].

* * * * *

Sunday or Holy-day] Inferior orders were conferred at stated times; but Consecration of Bishops could be held on all Sundays [III. Carthag. c. xxxix., A.D. 397]. Leo the Great wrote to Hilary of Arles, saying, "Nec sibi constare status sui noverit fundamentum, qui non die Sabbati vespere, quod lucescit in prima Sabbati, vel ipso Dominico die fuerit ordinatus;" adding, that this was the ancient rule, "majorum disciplina." Hugo de St. Victor [Theol. de Sac. Erud., l. ii. P. ii. c. xx.] says, "The Sacred Canons permit consecrations of Bishops on Sundays only." [Comp. Surius, A.D. 1035, tom. vii. c. xv. Maii iv.] Alcuinus Flaccus, of the ninth century, declares that Bishops being vicars of the Apostles, as of Christ, are consecrated on Sundays, because on that day the Lord, by the gift of the Holy Ghost, vouchsafed to illuminate the hearts of the Apostles [De Div. Off. Sabb., in xii. lection]. As Bishops are successors of Apostles, the proper day was extended to festivals of Apostles, and then to holydays in general. Thus, Pelagius II. was consecrated on St. Andrew's Day [in vita ab Anastasio], and Udalric, Bishop of Aosta, on the Holy Innocents' Day [Surius, Julii iv.].

in the Church] The usual custom was for a Bishop to be consecrated in his own cathedral, as St. Cyprian says [Ep. lxxviii.], "Diligenter de traditione Divina et Apostolica observatione servandum est et tenendum, quod apud nos quoque et fere per provincias universas tenetur, ut ad ordinationes rite celebrandas, ad eam plebem, cui Præpositus [al. Episcopus] ordinatur, Episcopi ejusdem provincie proximi quique convenient, et Episcopus deligatur plebe præsentem." Julius I., in his "Epistola ad Orientales," preserved in the second Apology of St. Athanasius, objects that George was not duly, according to the Canons, appointed and made Bishop at Alexandria, by the Bishops of the province. "Non oportuit creationem novi Episcopi illegaliter et præter Canonem Ecclesiasticum fieri, sed in ipsa Ecclesia." So St. Augustine requested the primate of Numidia to come and consecrate the new Bishop of Fussala [Ep. cclxi.]. By the IV. Council of Toledo, c. xviii., "Episcopus ibi consecrandus est ubi Metropolitanus eligeret; Metropolitanus tamen non nisi in civitate Metropoli;" and Thomassin [Discipl. P. ii. lib. ii.] gives numerous infractions of the rule of consecrating in a Bishop's own church.

after Morning Prayer is ended] The ancient time was the third hour, in memory of the descent of the Holy Ghost at Pentecost, and was appointed by Pope Anacletus [Gratian, dist. lxxv. Honorius, lib. i. cap. clxxxix. Glossa, Juris Canon. Ordin. dist. lxxv.]. The part of the Service where the Office of Consecration began varied, but, as Martene shows, invariably preceded the Gospel; thus the Pontificals of Noyon, Autun, and Rouen prescribe it at the Secret Prayer, but those of Besançon, after the Use of Tours and Rheims (a MS. 600 years old), at the preface. In the Greek Church the consecration took place before the Epistle [Goar. Rit. Græc. p. 302]. In some instances in the

Western Church, it immediately joined with the Canon in the Liturgy [Martene, ii. p. 329].

the Arch-bishop] A Bishop ought to be consecrated by his Metropolitan, or by the licence of the latter. That Metropolitan existed in the early centuries of the Church is shown by the Apostolical Canons, c. xxvi., P. Clement I. Ep. i., P. Stephen, Epist. iii., and, P. Anacletus, Ep. i., who says,—"Reliqui provinciales Episcopi, si necesse fuerit, cæteris consentientibus, a tribus, jussu Archiepiscopi, consecrari possunt Episcopi; sed melius est, si ipse cum omnibus eum elegerit, et cuncti pariter saeraverint pontificem." The Metropolitan was at first designated *πρῶτος ἐπισκόπων*, or, *πρόκριτος τῶν λοιπῶν* [Const. Apost. l. viii. c. iv.]. The metropolitan cities are defined by Tertullian [De Præsc., c. xx.], to be, "Ecclesias apud unamquamque civitatem, a quibus traducem fidei et semina doctrinæ; cætera exinde Ecclesias mutuatæ sunt, et quotidie mutuuntur ut Ecclesia fiant." Hallier [P. iii. s. v. c. iv.], traces through successive centuries the indefeasible right of the Metropolitan to consecrate his suffragans. The Bishops of the same province were to assist at consecrations, as Anacletus says [Epist. ii. dist. lxi. c. Ordin.], "Ordinationes Episcoporum auctoritate apostolica ab omnibus qui in eadem provincia Episcopi sunt celebrandæ." [Comp. St. Cypr., Ep. lxxviii. Euseb., l. vi. c. x. Rabanus Maurus, de Inst. Cleric., lib. i. c. iv. Isidore, de Eccles. Off. l. ii. c. vi. I. Council. Nicæa, c. iv. Laodicea, c. 365, c. xii. Antioch, 341, c. xix. Sardica, 347, c. v. IV. Carthage, 397, c. xxxix. Riez, 439, c. i. Chalcedon, 451, c. xxv. Orange, 441, c. xxi. Orleans, 538, c. iii. II. Council. Auvergne, 533. II. Council. Tours. III. Paris, 557, c. iii. Constantinople, 691. Rome under Sylvester. Aix, c. ix. Vienne, and Anjou, &c.]

or some other Bishop] The rubric immediately following the Gospel is more explicit: it says, "some other Bishop appointed by lawful commission." In the absence of the Archbishop the Bishop senior, according to consecration or in point of rank [Hallier, u. s. § viii.], was consecrator. A Metropolitan was consecrated by (1) Bishops of his province, or (2), the nearest Metropolitan, or (3), by the patriarch or primate [Ibid. art. ii. § i. II. Council. Orleans, c. vii. III. Orleans, c. iii.]. In case of two Bishops only acting at a consecration, they and the Bishop elect were deposed [Morinus, P. iii. Exerc. iv. § ii. v.].

The Collect] This Collect is identical with that for St. Peter's Day, omitting the Apostle's name, and with some slight verbal differences, and the insertion of the clause, "and duly administer the godly discipline thereof."

And another Bishop] Three Bishops are thus required, the Consecrator, the Epistoler, and Gospeller. In a Greek ritual of the fifteenth century, three Bishops present the Bishop elect [Assemani, xi. 160].

The Epistle and Gospel] The Epistle [1 Tim. iii. 1] is given by Morin [P. ii. 264], from a MS. more than 700 years old in

¶ *After the Gospel, and the Nicene Creed, and the Sermon are ended, the Elected Bishop (vested with his Rotchet) shall be presented by two Bishops unto the Arch-Bishop of that province (or to some other Bishop appointed by lawful Commission) the Arch-Bishop sitting in his chair near the holy Table, and the Bishops that present him saying,*

Acts i. 21—26.

MOST Reverend Father in God, we present unto you this godly and well-learned man to be Ordained and Consecrated Bishop.

¶ *Then shall the Archbishop demand the Queen's Mandate for the Consecration, and cause it to be read. And the Oath touching the acknowledgment of the Queen's Supremacy,*

¶ *Ipse vero electus sacerdotalibus vestibus induatur, præter casulam, et pro casula induatur capa, et sic duo comprovinciales episcopi deducant eum per manus coram metropolitano examinandum, ipso metropolitano sedente in loco examinationis, dorso verso ad majus altare . . .* Salisbury Use.

his time. It is given also in the Syr. Maronit. Ord. [Ib. P. ii. 356]. It occurs also in the "Ordo Romanus" and a Pontifical of Compiègne, according to the Use of Soissons [Catalani, § xiv. p. 191], and in the Sacramentary of Leofric [Bodl. Lib. fol. 278].

It was used also in Germany [Gerberti, p. 416]. The Gospel was,—

St. Matt.—"In illo tempore circubat . . . infirmitatem."

St. Mark.—"In illo tempore circubat . . . sanabantur."

St. Luke.—"In illo tempore convocatis Jesu discipulis . . . curantes ubique."

The following Epistles and Gospels are given in the "Comes Hieronymi" [Pamelius, ii. 60, 61].

"In ordinatione Episcoporum. Lectio Epistolæ B. Pauli Apost. ad Timotheum."

"Carissime, fidelis sermo, Si quis Episcopatum desiderat."

"Sequentia S. Evangelii secundum Johannem, Nisi granum frumenti."

"Sequentia S. Evangelii secundum Matthæum, Vigilate ergo quia nescitis."

"Item Lectio Epistolæ B. Pauli Apost. ad Titum, Oportet Episcopum sine crimine esse."

"Sequentia S. Evangelii secundum Marcum, Circubat Jesus in circuitu docens."

"Item Sequentia S. Evangelii secundum Matthæum, Convocatis Jesus duodecim."

"Item Sequentia S. Evangelii secundum Lucam, Designavit Jesus duodecim."

"Item Sequentia S. Evangelii secundum Johannem, Ego sum Pastor bonus."

The Gospel in an old Pontifical printed by Morin [p. 246], is from St. Luke xxii. 24—30; but from St. Mark, in the Pontifical of Compiègne according to the Use of Soissons of the sixth century, quoted by Catalani [i. p. 191], and in the "Ordo Romanus." In the Salisbury Pontifical, the Epistle is from Hebrews, "Fratres, omnis Pontifex . . . Melchisedec;" and the Gospel from St. John, "In illo tempore dixit Jesus discipulis suis . . . unus Pastor."

The Gospel from St. John xx. 19, occurs in the Syro-Nestorian Use [Morin, ii. 395].

vested with his Rotchet By the Sarum Pontifical, the elect was to wear his Priest's habit, except having a cope instead of a chasuble. A Pontifical of Rouen of the eleventh century, requires an albe, stole, and cope. By the Prayer Book of 1549, he was "to have upon him a surplice and cope," the presenting Bishops "being also in surplices and copes, and having their pastoral staves in their hands." The Rochet was prescribed for the use of Bishops by the Council of Arenda, 1473 [c. iii.]. The word Rochet is derived from the Anglo-Saxon *roc* by Somner and Spelman, but Meursius, Gerard Voss [De Vit. Serm., lib. ii. c. xvi.], and Ferrarius, derive it from the German *roch*. According to Ceccoperius, the French form of the name was adopted at

Avignon when the Popes resided there. The rochet differs from the albe in reaching only to the knees, and from a surplice, in having strait sleeves. In 1298, rochets are mentioned in an inventory of St. Paul's [Monast. iii. p. 331]. Cardinal Baronius, Gavanti and Georgius, think the "linea" worn by St. Cyprian was the rochet. Until the thirteenth century it was known as the linea, or *camisia Romana*, and corresponds to the mantle [Cær. Rom. l. i. c. i.]. Chaucer uses the word "rokette" [Romaunt of the Rose, 1240], and Bishop Latimer, in his sixth Sermon before Edward VI., mentions that he travelled in his rochet [Comp. St. Elphege's dress, Act. Sanct. ii. 130].

shall be presented by two Bishops "Episcopus qui ordinandus est duo Episcopi per manum de Secretario . . . deducant ante altare." [Morin, 250. 234. Comp. Martene, ii. p. 340.]

It appears by old Pontificals of Salzburg, Besançon, and Bec, that the consecrator sat in a throne before the altar, the two assistant Bishops facing him, and the elect in front of all. Simeon of Thessalonica [De Sac. Ord. c. vii.] represents the assistant Bishops seated on either side of the consecrator. The Bishop, when presented, will be in the centre, with the senior Bishop on his right hand; in the old Pontificals, he is required to bend the head, as a mark of subjection to the consecrator, and of humility in receiving the gift of God. In old Pontificals of Besançon [ann. dc.], Mayence [dc. ann.], Lyons [ccc. ann.], and the Use of Tarento, the consecrator inquired of the presenters whether they knew the elect to be worthy; they answered, "Scimus et credimus illum esse dignum, quantum humana fragilitas nosse sinit;" and all said, "Deo gratias." But this custom was abandoned when the Popes took elections and confirmations into their own hands [Catal. i: p. 178].

Most reverend Father in God In many ancient Pontificals the form ran, "Reverende Pater," but in the acts of the Council of Chalcedon, the title "Reverendissime" is used. The ancient Bishops were called Fathers by their juniors [Jo. Filusac, de Sac. Episc. Ordin. cap. x. § iv.]; and in the I. Council of Toledo, Bp. Duthius says, "I am of the same opinion as my lord and father, Bp. Symphosius." St. Augustine calls the elder Bishops fathers, and the juniors brothers [Epist. cx. So Paulinus, Epist. xxiv.]. St. Epiphanius [Hær. lxxv.], says, "Episcoporum ordo ad gignendos patres Ecclesiæ præcipue pertinet. Hujus enim est Patrum propagatio." [See also Bingham, Aut. B. ii. c. ii. § viii.]

the Queen's Mandate Estius, lib. iv. dist. xxiv. § xxxi. xxxii., proves that the lay people have a voice in the election of a Bishop. However, in lapse of time, as Van Espen [Jus. Eccles. P. i. tit. xiii. c. ii.] says in the twelfth century, "Elections of Bishops passed to the Cathedral Chapters, owing to the tumults and factions raised among the laity in such circumstances." [See Juennius de Sac. Ord. Diss. ix. qu. i.] John XXI. in 1322 [Raynauld, tom. xv. in app.] first reserved to himself the elections of Bishops in the provinces of Aquileia, Milan, Genoa, Pisa, and Naples, owing to the riots which had taken place, but added,

shall be ministered to the persons Elected, as it is set down before in the Form for the Ordering of Deacons. And then shall also be ministered unto them the Oath of due obedience to the Archbishop, as followeth.

The Oath of due Obedience to the Archbishop.

Heb. xiii. 17.

IN the Name of God. Amen. I *N.* chosen Bishop of the Church and See of *N.* do profess and promise all due reverence and obedience to the Archbishop, and to the Metropolitan Church of *N.* and to their successors: So help me God, through Jesus Christ.

¶ *This Oath shall not be made at the Consecration of an Archbishop.*

¶ *Then the Archbishop shall move the Congregation present to pray, saying thus to them:*

Luke vi. 12, 13.
Acts xiii. 1—4.
Heb. iii. 1.
1 Cor. xi. 1.

BRETHREN, it is written in the Gospel of S. Luke, That our Saviour Christ continued the whole night in prayer, before he did choose and send forth his twelve Apostles. It is written also in the Acts of the Apostles, That the Disciples who were at Antioch did fast and pray, before they laid hands on Paul and Barnabas,

IN Dei nomine. Amen. Ego *N.* talis Salisbury Use. ecclesie electus, et a te, reverende pater, nomine *N.* Cantuariensis archiepiscopi, totius Angliæ primas, consecrandus antistes, tibi et sanctæ Cantuariensi ecclesie metropolitanae, tuisque successoribus in dicta ecclesia Cantuariensi canonice substituendis, debitam et canonicam obedientiam, reverentiam et subjectionem me per omnia exhibiturum profiteor et promitto . . . sic me Deus adjuvet, et sancta Dei evangelia. Et prædicta omnia subscribendo propria manu confirmo.

ADESTO supplicationibus nostris, omnipotens Deus, ut quod nostræ humilitatis gerendum est ministerio, tuæ virtutis impleatur effectus.

that he only took this step until, the storm being past (he alludes to the rival Pope at Avignon), full security in elections could be secured to churches. In 1448, by concordat between P. Nicholas V. and the Emperor Frederick III., elections were to be made in cathedrals and abbey churches; and by concordat between P. Leo X. and Francis I. at Bologna in 1516, it was agreed that elections should no longer take place in metropolitan or cathedral churches of the kingdom, Dauphiny, or the provinces of Die and Valence, but that on a vacancy the king should nominate a Doctor or Licentiate in Divinity or Law, of the age of twenty-seven years, within six months after such a vacancy, and the Pope should issue his bull. In Spain, by concordat between Charles V. and P. Adrian VI., it was agreed that the nomination of all Bishops and Abbots should be vested in the Crown [Mariana, lvi. c. v.]; and in Naples Clement VII. gave to Charles V. the right of nomination to twenty-four sees [See also Thomassin, de Vet. et Nov. Eccles. Disc. lib. ii. c. xxxv. Catalani, de Cons. Elect. i. tit. xiii.]. In some instances the king sent a precept signed by his own hand, or an indulus without the privy seal, nominating a Bishop; and in Spain [XII. Toledo, c. vi.], the Archbishop of Toledo acted as the king's delegate [Hallier, P. vii. S. v. § vii.]. Thomassin [P. ii. liv. ii. chap. 34, § 8], shows that in the sixth and seventh centuries the kings of France issued mandates for consecration.

Oath of due Obedience In the Greek Church, the oath of allegiance to the Emperor is required [King's Rites of Greek

Church, pp. 295—299]. By the XI. Council of Toledo, A.D. 675, an oath of obedience to his superior was exacted from a Bishop elect [Thomassin, P. ii. liv. ii. ch. 41]; and in the ninth century, Gaulish Bishops made professions of obedience to their Metropolitans [Ib. P. iii. l. ii. ch. 36]. An ancient form was as follows.—“Ego ille Sanctæ N. Ecclesie nunc ordinandus Episcopus subjectionem et reverentiam a sanctis Patribus constitutam secundum præcepta Canonum, S. sedis N. Ecclesie rectoribusque ejus in præsentia domini Archiepiscopi perpetuo me exhibiturum promitto et super sanctum altare propria manu firmo.” [Ex. Pont. Turon., ann. dcc. ætat. superante, Martene, II. 415.] In the Roman Pontifical, the oath of obedience to the Pope is here made by the Elect [Catal. i. 178—179].

In the Sarum Pontifical the profession given above is preceded by the question, “Vis sanctæ Cantuariensi Ecclesie et mihi, meisque successoribus subjectionem, et obedientiam per omnia exhibere, secundum canonicam auctoritatem, et decreta sanctorum pontificum? Resp. Volo.” The same question occurs with slight variations in the Winton and Bangor Pontificals. In that of Exeter is this remarkable addition, “Vis beato Petro Apostolo, cui a Deo data est potestas ligandi atque solvendi, ejusque vicariis, Romanis pontificibus, atque sanctæ ecclesie Cant.” &c. All three Pontificals omit the form in which the profession itself is to be made.

Brethren, it is written In the Gallican Liturgy is an “Exhortatio ad populum cum Episcopus ordinatur:” it ends, “Nunc

and sent them forth. Let us therefore, following the example of our Saviour Christ, and his Apostles, first fall to prayer; before we admit and send forth this person presented unto us, to the work whereunto we trust the Holy Ghost hath called him.

¶ *And then shall be said the Litany, as before in the Form of Ordering Deacons; Save only, that after this place That it may please thee to illuminate all Bishops, &c. the proper Suffrage there following shall be omitted, and this inserted instead of it;*

John xv. 16.
Eph. iv. 11, 12.
* i. 22, 23.
1 Pet. iv. 10, 11.

THAT it may please thee to bless this our brother Elected, and to send thy grace upon him, that he may duly execute the Office whereunto he is called, to the edifying of thy Church, and to the honour, praise and glory of thy Name;

Answer.

We beseech thee to hear us, good Lord.

¶ *Then shall be said this Prayer following.*

Matt. vii. 11.
Eph. iv. 11—13.

ALmighty God, giver of all good things, who by thy Holy Spirit hast appointed divers Orders of Ministers in thy Church; mercifully behold this thy servant now called to the work and Ministry of a Bishop; and replenish him so with the truth of thy doctrine, and adorn him with innocency of life, that, both by word and deed, he may faithfully serve thee in this Office, to the glory of thy Name, and the edifying and well-governing of thy Church; through the merits of our Saviour Jesus Christ, who liveth and reigneth with thee and the Holy Ghost, world without end. *Amen.*

¶ *Then the Archbishop, sitting in his Chair, shall say to him that is to be Consecrated,*

Oremus, dilectissimi nobis, ut huic Salisbury Use. viro ad utilitatem ecclesie provehendo, benignitas omnipotentis Dei gratiae suae tribuat largitatem. Per Dominum.

¶ *Et statim a duobus episcopis incipiatur: Kyrie eleison, Cum litania . . . et dicatur litania sicut in ordinibus, et cum ventum fuerit ad versum qui pro domino episcopo cantatur, surgat consecrator, et dicat conversus ad electum sic:*

UT hunc electum benedicere digneris.

Resp. Te rogamus.

Ut hunc electum benedicere et sanctificare digneris.

Resp. Te rogamus.

Ut hunc electum benedicere, sanctificare et consecrare digneris.

Resp. Te rogamus.

. . . . Domine sancte, Pater omnipotens, æterne Deus: Honor omnium dignitatum, quæ gloriæ tuæ sacris famulantur ordinibus Et idcirco huic famulo tuo, quem ad summi sacerdotii ministerium elegisti, hanc, quæsumus Domine, gratiam largiaris, ut quicquid illa velamina in fulgore auri signabant, hoc in ejus moribus actibusque clarescat. Comple, Domine, in sacerdote tuo ministerii tui summam

. . . ipso metropolitano sedente in loco examinationis . . . Tunc dicat metropolitanus:

igitur, dilectissimi fratres, testimonii boni operis electum, dignissimum sacerdotio consonantes laudibus clamate et dicite dignus est." [Migne, l. xxii. p. 325.] The elect was at this part of the service recommended in some old forms to say in private or secretly the penitential Psalms, and Ps. cxv., "Credidi;" Ps. lxxxiv., "Benedixisti;" Ps. lxxvi., "Fundamenta;" Ps. lxxxv., "Inclina;" Ps. cxxxi., "Memento;" Ps. lxxxvii., "Domine;" Ps. lxxxiii., "Quam dilecta."

The Litany] The Litany was enjoined by the "Ordo Romanus" and a Pontifical of Lyons of the third century [Catalani, i. 194]: "Tunc duo Episcopi incipiant Litaniam, et inter alia dicant, Ut fratrem nostrum electum pontificem in vera religione conservare digneris." [Morinus, 275. Assemani, e Cod. dc. ann., Cod.

Liturg. viii. 180.] The Litany always formed part of the Greek ordinations [Goar., Rit. Gr. p. 303. Assemani, Cod. Liturg. x. p. 13. Martene II., 362. 372. 404. Morin, 361]. The Greek petitions were, "Ἐπεὶ τοῦ δούλου τοῦ Θεοῦ, τοῦ δεινός, τοῦ νυνὶ προχειριζομένου Ἐπισκόπου καὶ τῆς σωτηρίας αὐτοῦ τοῦ Κυρίου δεηθῶμεν. Ὅπως ὁ φιλόανθρωπος Θεὸς ἑσπῆλον καὶ ἀνάμνητον αὐτοῦ τὴν ἀρχιερωσύνην χάρισθαι τοῦ Κυρίου δεηθῶμεν." [Goar. p. 303.] The Litany in the Church of Constantinople occurs in a later part of the Office [Goar. 303]; in the Syro-Nestorian ritual, after the Gospel [Assemani, x. 18]; in some western uses before [Martene II., 362. 372], in others after the Epistle [Ib. p. 404].

1 Tim. v. 22.
Actis xx. 28.
1 Tim. iii. 2. 7.

BROTHER, forasmuch as the holy Scripture and the ancient Canons command, that we should not be hasty in laying on hands, and admitting any person to government in the Church of Christ, which he hath purchased with no less price than the effusion of his own blood; before I admit you to this Administration, I will examine you in certain Articles, to the end that the Congregation present may have a trial, and bear witness, how you be minded to behave yourself in the Church of God.

ARE you persuaded that you be truly called to this Ministration, according to the will of our Lord Jesus Christ, and the Order of this Realm?

Answer.

I am so persuaded.

The Archbishop.

2 Tim. iii. 15.
Titus i. 7. 9.
ii. 1.

ARE you persuaded that the holy Scriptures contain sufficiently all doctrine required of necessity to eternal salvation through faith in Jesus Christ? And are you determined out of the same holy Scriptures to instruct the people committed to your charge; and to teach or maintain nothing as required of necessity to eternal salvation, but that which you shall be persuaded may be concluded and proved by the same?

Answer.

I am so persuaded, and determined, by God's grace.

ANTIQUA sanctorum patrum institutio docet et præcipit, ut is qui ad ordinem episcopatus eligitur, antea diligentissime examinetur cum omni caritate, de fide sanctæ Trinitatis, et interrogetur de diversis causis vel moribus, quæ huic regimini congruunt, et necessaria sunt retineri, secundum apostoli dictum, manus cito nemini imposueris; et ut etiam is qui ordinandus est antea erudiat, qualiter sub hoc regimine constitutum oporteat conversari in ecclesia Dei, et ut irreprehensibiles sint etiam, qui ei manus ordinationis imponunt.

EADEM itaque auctoritate, et præcepto, interrogamus te, dilectissime frater, caritate sincera, si omnem prudentiam tuam, quantum tua capax est natura, divinæ Scripturæ sensibus accommodare volueris?

Resp. Ita volo, ex toto corde, in omnibus obedire et consentire.

THE EXAMINATION.

An examination was appointed by the IV. Council of Carthage, c. i., and by II. Nicæan, c. xi. See also Martene, de Ant. Rit. lib. i. c. viii., Art. X. n. viii. The following form is from an Italian Pontifical, and one of the eighth century:—"Sedeat dominus Papa in sua sede, facto ibi silentio fiat examinatio talis. Antiqua S. Patrum institutio docet et præcipit, ut is qui ad ordinem Episcopatus eligitur, maxime, ut legitur in Canone Carthaginensi, antea diligentissime examinetur cum omni caritate de fide SS. Trinitatis, et interrogetur de diversis causis vel moribus quæ huic regimini congruunt, et necessaria sunt retineri, secundum Apostoli dictum 'Manus cito nemini imposueris,' et ut etiam is qui ordinandus est antea erudiat, qualiter sub hoc regimine constitutum oporteat conversari in Ecclesia Dei . . . eadem itaque auctoritate et præcepto interrogamus te, dilectissime frater." [Pont. of Bari, Catalani, i. tit. xiii. App. pp. 228, 229. Morin, p. 263, ex cod. dcc. ann. Martene, e cod. dcccc. ann., ii. p. 386.] In the Vatican MS. of Gregory's

Sacramentary, the rubric runs, "Examinatio in ordinatione Episcopi ante Litaniam facienda." [Migne, lxxviii. 223.] In the Sarum Pontifical the Examination is much longer than in the Prayer Book, and includes a series of questions on the Creed and articles of the faith. In the Greek Church the Bishop elect is also examined in the Creed and articles of the faith [Assemanni, P. iv. 233, &c.].

In the very ancient "Ordo Romanus" [Mabillon, Mus. Ital. i. p. 87], the Bishop of Rome, sitting in his chair, calls to him Bishops or Priests and bids them sit with him. The whole Clergy standing, he bids his chaplain desire the people of the city to enter. While he goes to bring them in, the Bishop chooses one of the Priests to answer his questions. When they are brought in, they are inquired of by the Bishop, "Quid est, fratres, quod vos fatigastis?" They answer, "Ut nobis concedas patronum. Habetis vestrum? R. Habemus. Quo honore fungitur? R. Diaconus," Presbyter, or what he is. "Quantos annos habet in Diaconatu aut Presbyteratu? R. —. De ipsa Ecclesia est an de alia? De ipsa," (but if of any other Church)

The Archbishop.

John v. 39.
Ps. cxix. 18.
Ezek. iii. 17.
Titus ii. 7, 8.
2 Tim. iv. 2.

WILL you then faithfully exercise your self in the same holy Scriptures, and call upon God by prayer, for the true understanding of the same; so as ye may be able by them to teach and exhort with wholesome doctrine, and to withstand and convince the gain-sayers?

Answer.

I will so do, by the help of God.

The Archbishop.

Titus i. 5. iii. 10.

BE you ready, with all faithful diligence, to banish and drive away all erroneous and strange Doctrine contrary to God's Word; and both privately and openly, to call upon and encourage others to the same?

Answer.

I am ready, the Lord being my helper.

The Archbishop.

Titus ii. 11, 12.
1 Tim. iii. 1—7.
iv. 12. v. 14.
Titus ii. 7, 8.

WILL you deny all ungodliness and worldly lusts, and live soberly, righteously, and godly, in this present world; that you may shew your self in all things an example of good works unto others, that the adversary may be ashamed, having nothing to say against you?

Interrogatio. Vis ea quæ ex divinis Salsbury Use. Scripturis intelligis, plebem cui ordi-
nandus es, et verbis docere et exem-
plis?

Resp. Volo.

Interrogatio. Vis mores tuos ab
omni malo temperare, et quantum
poteris, Domino adjuvante, ad omne
bonum commutare?

Resp. Volo.

"Dimissorium habet de Episcopo suo? R. Habet." They produce the letter. "Conjugem habuit? Disposuit de domo sua? R. Disposuit. Quid vobis complacuit de eo? R. Et castitas, hospitalitas, benignitas, et omnia bona quæ de eo sunt prolata. Videte, fratres, ne aliquam promissionem fecisset vobis. Scitis quod simoniacum et contra Canones est. R. Absit a nobis. Vos videritis. Habetis decretum? R. Habemus." It is then read by the chaplain, and when it has been read the Elect is brought in. The Bishop says, "May God protect us;" and then says to the Elect, "What seekest thou, brother?" to which he replies, "That of which I am not worthy; my fellow-servants led me on." "What honour have you fulfilled? R. Deacon or Priest," &c. "How long have you been in the Diaconate?" &c. He states the time. He is then asked, "Had you a wife," and "Have you disposed of your household?" whether he has made a simoniacal covenant, "What books are read in your church?" "Do you know the Canons?" to the last the Elect replies, "Teach us, sir;" to which the answer is, "Ordain at the proper seasons, January, April, September, December." The petition from the people is then read, and the consecration deferred to the morrow, Sunday. On that day the Bishop, with Bishops, and Priests, and clerks enter the church, and, after the Introit, follow a prayer and the Epistle from 1 Timothy, "Fidelis sermo." While the gradual is sung, the Elect is vested by the Archdeacons, sub-Deacons, and acolytes, with dalmatic, chasuble, and staff, and brought in: the Bishop says, "The Clergy and people of . . . have

chosen . . . to be consecrated Bishop; let us pray that our Lord God Jesus Christ may grant unto him the episcopal chair, to rule the Church and all the people." The Litany follows, and the Elect receives the benediction. After the Alleluia, follow the Gospel and Mass, and the newly-consecrated Bishop communicates the people.

In another "Ordo" of St. Gall (p. 91), at night, after the Introit, the Bishop of Rome says, "Gloria in excelsis;" and there is a prayer; then one Priest and one Deacon, going from the altar, lead in the Elect, having clothed him with albe (linea) and girdle, "analogium," the little dalmatic, brachiale, stole, and great dalmatic, whilst the choir sing "Immola Deo," the tract "Qui seminat," and the Gospel, "Misit illos binos ante faciem suam." He is then led up by a Priest on the right, and Deacon on the left. They then take off his chasuble, and the Bishop reads the brief, "Our citizens have chosen this man as their pastor, let us pray that Almighty God will pour down on him the Spirit of His grace, and that he may be worthy to govern in the episcopal chair." The choir sing the Kyrie and Litany. The Elect bows his head before the altar, and the Bishop, laying his hand upon him, says a prayer like a collect, and sings another as the Preface (contestata) is chanted. The newly-ordained Bishop kisses the Bishop's feet, and receives the kiss of peace.

Will you then faithfully exercise, &c.] The study of Holy Scriptures is required by the Council of Tours, 813, c. ii., iii., iv.

Answer.

I will so do, the Lord being my helper.

The Archbishop.

2 Tim. ii. 16. 22
—25. iv. 2.
Tit. i. 13. ii. 15.
1 Tim. i. 9—11.
v. 20. 19.
2 Cor. xiii. 10.

WILL you maintain and set forward, as much as shall lie in you, quietness, love, and peace among all men; and such as be unquiet, disobedient, and criminous, within your Diocese, correct and punish, according to such authority as you have by God's word, and as to you shall be committed by the Ordinance of this Realm?

Answer.

I will so do, by the help of God.

The Archbishop.

Titus i. 5.
2 Tim. ii. 2.
Acts xiv. 23.

WILL you be faithful in Ordaining, sending, or laying hands upon others?

Answer.

I will so be, by the help of God.

The Archbishop.

2 Tim. ii. 24.
Luke vi. 36.
1 John iii. 17.
Heb. xiii. 2.

WILL you shew yourself gentle, and be merciful for Christ's sake to poor and needy people, and to all strangers destitute of help?

Answer.

I will so shew myself, by God's help.

¶ *Then the Archbishop standing up shall say,*

ALMIGHTY God, our heavenly Father, who hath given you a good will to do all these things, Grant also unto you strength and power to perform the same; that, he accomplishing in you the good work which he hath begun, you may be found perfect and irreprehensible at the latter day; through Jesus Christ our Lord. *Amen.*

¶ *Then shall the Bishop elect put on the rest of the Episcopal habit; and kneeling down, [Veni, Creator Spiritus] shall be sung or said over him, the Archbishop beginning, and the*

Interrogatio. Vis semper esse divinis negotiis mancipatus, et a terrenis negotiis vel lucris turpibus esse alienus, quantum te humana fragilitas concesserit posse?

Resp. Volo.

Interrogatio. Vis humilitatem, et patientiam, in temetipso custodire, et alios similiter docere?

Resp. Volo.

Interrogatio. Pauperibus et peregrinis, omnibusque indigentibus vis esse, propter Nomen Domini, affabilis et misericors?

Resp. Volo.

Tunc dicat ei pontifex:

HÆC omnia et cætera bona tribuat tibi Dominus, et custodiat te, atque corroboret, in omni bonitate.

Respondeant omnes astantes: Amen.

Hæc tibi fides augeatur a Domino ad veram et æternam beatitudinem, dilectissime frater in Christo.

Et respondeant omnes: Amen.

.... *et dicat ordinator: Veni, Creator, ut supra in ordinibus.*

Will you shew yourself gentle, &c.] This kindness to the poor and strangers is enjoined by the Council of Tours, A.D. 813, c. iv. v. vi.

Almighty God] Assemanni [P. iv. 241] gives the following benediction as in use in the Greek Church:—*Ἡ χάρις τοῦ παναγίου Πνεύματος εἴη μετὰ σοῦ φωρίζουσα, στηριζουσα, καὶ σωτηρίζουσα σε πάσας τὰς ἡμέρας τῆς ζωῆς σου.*

Then shall the Bishop elect] After the benediction ("Adesto supplicationibus nostris," &c.), the Salisbury Pontifical has this rubric:—"Interim autem, dum hæc fiunt, innuat dominus metro-

politanus Archidiacono, et ipse descendens cum acolytis et sub-Diaconis vadat extra chorum, ubi expectat qui ordinandus est, et accipiens vestimenta induat eum cum sandaliis, alba, stola, manipulo, tunica, dalmatica, et casula, sine mitra et absque baculo vel annulo." By the Sarum Pont., two Bishops vested in copes lead the Elect up to the consecrator; by the Bangor, two Bishops in chasubles. By the Winchester Pontifical, the Archdeacon leads the Elect up to the Altar where the Metropolitan is standing, and presents him. The Winchester rubric, with regard to the vesting of the elect Bishop, is simply . . . "et accipiens vestimentum

Bishops, with others that are present, answering by verses, as followeth.

COME, Holy Ghost, our souls inspire,
 And lighten with celestial fire.
 Thou the anointing Spirit art,
 Who dost thy seven-fold gifts impart.
 Thy blessed Unction from above,
 Is comfort, life, and fire of love.
 Enable with perpetual light
 The dulness of our blinded sight.
 Anoint and cheer our soiled face
 With the abundance of thy grace.
 Keep far our foes, give peace at home:
 Where thou art guide, no ill can come.
 Teach us to know the Father, Son,
 And thee, of both, to be but One.
 That through the ages all along,
 This may be our endless song;
 Praise to thy eternal merit,
 Father, Son, and Holy Spirit.

¶ Or this:

COME, Holy Ghost, eternal God,
&c. as before in the Form of Ordering Priests.
 ¶ That ended, the Archbishop shall say,
 Lord, hear our prayer.

Answer.

And let our cry come unto thee.

Let us pray.

ALMIGHTY God, and most merciful Father, who of thine infinite goodness hast given thine only and dearly beloved Son Jesus Christ, to be our Redeemer, and the Author

[For the original of this hymn see form for Ordination of Priests.]

induat eum," omitting the list of vestments given in the Salisbury Pont. [Maskell, Mon. Rit. iii. 253, 254]. By the first Prayer Book of Edward VI., confirmed by Act 2 & 3 Edw. VI. c. i. [comp. Cranmer's Memorials, c. xxiv. 363—364], whensoever the Bishop shall celebrate the Holy Communion in the church, or execute any other public ministration, he shall have upon him beside his rochet a surplice or albe, and also a cope or vestment [i.e. cope or chasuble], and also his pastoral staff in his hand, or else borne or holden by his chaplain. Bp. Goodrich, of Ely, 1554, Bp. Bell, of Worcester, 1556, Bp. Fursglove, of Hull, 1579, and Archbishop Harsnet, 1631, are represented on their brasses in mitre, cope, and rochet, and holding the pastoral staff. The mitres and pastoral staves of Trelawny and Mews are preserved in Winchester Cathedral; Laud's staff is in St. John's College, Oxford, and there is one of Caroline date in the vestry of York Minster. Mitres were worn at a coronation in the last century; pastoral staves are now carried before several of our Bishops; copes are worn at coronations and royal marriages and christenings. The Primate wore his cope in Convocation in 1562 and 1640, and Bp. Cosin wore a white satin cope without embroidery. The *chimere* is a

dress of black satin with lawn sleeves [Soames, iii. 560], the latter properly belonging to the rochet. Hody says, that in the reigns of Henry VIII. and Edward VI. the Bishops wore their Doctor of Divinity scarlet habit with their rochet, the colour being changed for the present ugly and unauthorized black satin chimere late in the time of Q. Elizabeth. The following notices occur of the chimere, but the derivation of the name is unknown:—"Chimeres and Rochets" [Abp. Parker's Works, p. 475]. *Chimere*, a robe made of velvet, program, or satin, used also in riding [Archæol., xxx. 17], a gown cut down the middle, generally used by persons of rank and opulence [Halliwell]. "A scarlet episcopal gown" [3 Zur. Lett. 271]. "His upper garment a long scarlet chimere, down to the feet, and under that a white linen rochet." [Foxe, vi. 641.]

Veni, Creator Spiritus. In the Ordo preserved by Morin [p. 265], here follows the Sermon. In the Bari Pontifical, after the "Vere Dignum," the "*Veni Creator Spiritus*" is added in a later hand [Catalani, i. p. 230]. This hymn does not occur in the Sacramentary of St. Gregory, the ancient "*Ordo Romanus*," or the early Pontificals; but it appears from the Use of Lyons,

of everlasting life; who, after that he had made perfect our Redemption by his death, and was ascended into heaven, poured down his gifts abundantly upon men, making some Apostles, some Prophets, some Evangelists, some Pastors and Doctors, to the edifying and making perfect his Church; Grant, we beseech thee, to this thy servant such grace, that he may evermore be ready to spread abroad thy Gospel, the glad tidings of reconciliation with thee; and use the authority given him, not to destruction, but to salvation; not to hurt, but to help: so that as a wise and faithful servant, giving to thy family their portion in due season, he may at last be received into everlasting joy; through Jesus Christ our Lord, who, with thee and the Holy Ghost, liveth and reigneth, one God, world without end. *Amen.*

James i. 17.
Rom. i. 15. 11. 13.
x. 15.
2 Cor. v. 18. x. 8.
2 Tim. ii. 25, 26.
Matt. xxiv. 45.

Luke xii. 42. 44.
Matt. xxv. 21.
2 Tim. iv. 8.

¶ *Then the Archbishop and Bishops present shall lay their hands upon the head of the elected Bishop kneeling before them upon his knees, the Archbishop saying,*

John xx. 21, 22.
Matt. xxviii. 20.
Acts xix. 6.
xx. 17, 18, 28.
1 Pet. iv. 10.
2 Tim. i. 6, 7.

RECEIVE the Holy Ghost, for the Office and Work of a Bishop in the Church of God, now committed unto thee by the Imposition of our hands; In the Name of the Father, and of the Son, and of the Holy Ghost. Amen. And remember that thou stir up the grace of God which is given thee by this Imposition of our hands: for God hath not given us the spirit of fear, but of power, and love, and soberness.

. . . . Sint speciosi, munere tuo, pedes Salisbury Use. ejus ad evangelizandum pacem, ad evangelizandum bona tua. Da ei, Domine, ministerium reconciliationis, in verbis et in factis, in virtute signorum et prodigiorum. Sit sermo ejus, et prædicatio, non in persuabilibus humanæ sapientiæ verbis, sed in ostensione spiritus et virtutis. Da ei, Domine, claves regni cælorum, ut utatur, non gloriatur, potestate quam tribuis in ædificationem, non in destructionem Sit fidelis servus et prudens, quem constituas tu, Domine, super familiam tuam; ut det illis cibum in tempore opportuno *Terminando secreta:* Per Dominum nostrum Jesum Christum Filium tuum, qui tecum vivit et regnat, in unitate Spiritus Sancti, Deus. Per omnia sæcula sæculorum.

Et respondeant omnes: Amen.

that in certain churches a Mass of the Holy Ghost was sung, and in others that this hymn was used. In the Euchologium of Allatius after the profession of faith by the Elect, the consecrator said,—“*Gratia Spiritus Sancti sit tecum*” [§ xxi. tom. i. p. 201]. By the Pontifical of Mayence, about the twelfth century, the Mass of the Holy Ghost was ordered to be sung, and also by the Pontifical of Lyons, written in the fourteenth century [Catalani, § xiv. p. 191]. Thomassin has printed this hymn in his collection of very ancient hymns of the ancient Church [Op. tom. ii. p. 375. See also Brev. Sarisb. Pars hiemalis, fol. 97, MS. Sarisb.

fol. 71]. The first English version (added in 1602), has been attributed to John Dryden.

Receive the Holy Ghost] None of the old English Pontificals, except the Exeter, contain this “Form;” and Martene acknowledges, “*Verba illa toti antiquitati ignota fuerunt: adeo ut vix in ullo Pontificali annos 400 attingente reperiantur. Nam ex omnibus quæ percurrimus, tria tantum illa habent, Arelatense, Andegavense, et Gulielmi Durandi.*” The “Form” occurs in the Roman Pontifical. In the Greek Church the form is, Ἡ θεία χάρις, ἡ πάντοτε τὰ ἀσθενῆ θεραπεύουσα, καὶ τὰ ἐλλείποντα ἀνα-

¶ Then the Archbishop shall deliver him the Bible, saying,

1 Tim. iv. 13—16.
John x. 2, 12.
Acts xx. 28, 29.
1 Pet. v. 1—8.
Ezek. xxxiv. 2—
4, 11, 16.
1 Thess. v. 14.
Luke iv. 18.
ix. 10.
2 Cor. x. 1, 2, 8, 9.
ii. 3, 5, 6, 10.
1 Pet. v. 4.

GIVE heed unto reading, exhortation, and doctrine. Think upon the things contained in this Book. Be diligent in them, that the increase coming thereby may be manifest unto all men. Take heed unto thyself, and to doctrine, and be diligent in doing them: for by so doing thou shalt both save thyself and them that hear thee. Be to the flock of Christ a shepherd, not a wolf; feed them, devour them not. Hold up the weak, heal the sick, bind up the broken, bring again the out-casts, seek the lost. Be so merciful, that you be not too remiss; so minister discipline, that you forget not mercy: that when the chief Shepherd shall appear you may receive the never-fading crown of glory; through Jesus Christ our Lord. *Amen.*

¶ Then the Archbishop shall proceed in the Communion-Service; with whom the new Consecrated Bishop (with others) shall also communicate.

¶ Postea, det eis codicem evangeliorum, dicens: Salisbury Use.

ACCIPE evangelium et vade, prædica populo tibi commisso.

Quum datur baculus dicat ordinator:

Accipe baculum pastoralis officii: et sis in corrigendis vitiis pie sæviens, iudicium sine ira tenens, in fovendis virtutibus auditorum animos demulcens, in tranquillitate severitatis censuram non deserens.

¶ Et dominus metropolitanus, vel consecrator, peragat missam.

πληροῦσα, προχειρίζεται τὸν δέινα, τὸν θεοφιλέστατον Πρεσβύτερον, Ἐπίσκοπον. [Goar., Rit. Gr. p. 302.]

shall deliver him the Bible] St. Dionysius in Eccles. Hier., c. v., explains the delivery of the Gospels to imply the necessity of knowing, preaching, and meditating, on them. [See also Durandus l. ii. c. xi. Syn. Thess., c. vii. P. Damian, Serm. i. de Dedie. Amal. Fort. l. ii. c. xiv, and Haberti in Obs. ad Pont. Græc. p. 79.]

The IV. Council of Carthage, c. ii., directs, "Episcopus cum ordinatur, duo Episcopi ponant et teneant Evangeliorum codicem super caput et cervicem ejus: et uno super eum fundente benedictionem, reliqui omnes Episcopi, qui adsunt, manibus suis caput ejus tangant." In the first Prayer Book of Edward VI., 1549, this old tradition was observed, for the Archbishop was required to "lay the Bible upon his (the elected Bishop's) neck."

The Roman Pontifical requires the open Gospels to be laid without a word on the neck of the Elect, and Catalani says, that with this agree the Greek and Syrian rituals, a Pontifical of Mayence, and Roger Wendover, s. a. 1093.

A MS. of Arles quoted by Martene [De Ant. Eccles. Rit., l. i. c. viii. Art. X. n. xv.], leaves it indifferent whether open or closed, and so do Latin rituals, except the "Ordo Romanus" and that of C. Cajetan, which prescribe it to be closed; but the Apost. Constit. [lib. viii. c. iv.], Symeon of Thessalonica [c. vii.], and the Greek Maronite and Jacobite rites prescribe it to be open. Two old Pontificals require the Gospels to be laid between the shoulders and on the neck, the Greek rituals and Symeon of Thessalonica say it was to be laid on the back of the head and neck (τῆ κεφαλῇ καὶ τῷ τραχήλῳ) and the Nestorians, on the back. Three Deacons held the book [Const. Apost., lib. viii. c. iv.]; but the "Ordo Romanus" [IV. Counc. Carth., c. ii.], the Sacramentary of Gregory, and other rituals, appoint Bishops for the act. From the words of the Gospel which chanced to open, the superstitious of the Middle Ages drew auguries, and this custom seems to have led to the direction that the book should be shut. Amalarius

Fortunatus [De Off. Eccles., l. ii. cxiv.] says of this ceremony, "Neque vetus auctoritas infimat, neque Apostolica traditio, neque Canonica auctoritas;" Alcuin [De Div. Offic.] agrees with Amalarius. This statement must be somewhat corrected, as we find the rite enjoined in the Pontifical of Egbert, the Sacramentary of St. Gregory, and the IV. Council of Carthage. Hallier makes this, with the laying on of hands, two forms, as he notes two matters of Consecration, "Receive the Holy Ghost," and, "Take the Gospel" [P. iii. s. viii. c. ix. Art. 3]. Probably the custom of the delivery of the Bible was derived from the old English custom of giving the Gospel to the Deacons, mentioned 900 years ago as Martene shows [tom. ii. p. 314].

Give heed unto reading, &c.] The following passages may be cited as illustrating this charge:—"Sint speciosi muere Tuo pedes horum ad Evangelizandam pacem, ad Evangelizandum bona Tua. Da eis, Domine, ministerium reconciliationis . . . Utantur nec gloriantur potestate, quam tribuisti, in ædificationem, non in destructionem. Sint servi fideles et prudentes quos constituas Tu, Domine, super familiam Tuam, ut dent illis cibum in tempore necessario" [Morin, P. ii. 216. MS. Leofrici, fol. 280. Pont. Egberti, Eboracensis. Martene, p. 341. Gelasii Sacram. Muratori, Lit. Rom. Vet. tom. i. pp. 625, 626].

"Cum baculus datur.—Accipe baculum sacri regiminis signum, ut imbecillos consolides, titubantes confirmes, parvos corrigas, rectos diriges in viam salutis æternæ" [Morin, P. ii. 266, ex. cod. ann. dcc. ætat superante]. In the Greek ritual occurs, λάβε τὰς τὴν βακτηρίαν ἵν' ἐφ' ἣ στηριζόμενος θεοφιλῶς τὸ ποιμνίον σου, ὅτι καὶ λόγον μέλλεις ἀποδοῦναι ὑπὲρ αὐτοῦ τῷ Θεῷ ἐν ἡμέρᾳ κρίσεως. [Assemani, P. iv. p. 281.]

"Pascite gregem Dei, qui creditus est manibus vestris, et visitate illum spiritualiter, non violentem sed sponte, non propter lucra turpia . . . ut sitis bonum exemplar, ut cum apparebit Princeps Pastorum, accipiatis ab eo coronam quæ non marcescit" [Morin, Ord. Syr. Maron. P. ii. p. 355].

¶ *And for the last Collect, immediately before the Benediction, shall be said these Prayers.*

Ps. lxxvii. 1.
2 Tim. i. 2.
iv. 3—8.
1 Tim. iv. 11, 12.
14, 15.
2 Tim. iv. 4—8.
Rev. ii. 10.
1 Tim. vi. 13—16.

MOST merciful Father, we beseech thee to send down upon this thy servant thy heavenly blessing; and so endue him with thy holy Spirit, that he, preaching thy Word, may not only be earnest to reprove, beseech, and rebuke with all patience and doctrine; but also may be to such as believe a wholesome example, in word, in conversation, in love, in faith, in chastity, and in purity; that, faithfully fulfilling his course, at the latter day he may receive the crown of righteousness laid up by the Lord the righteous Judge, who liveth and reigneth one God with the Father and the Holy Ghost, world without end. *Amen.*

PREVENT us, O Lord, in all our doings, with thy most gracious favour, and further us with thy continual help; that in all our works begun, continued, and ended in thee, we may glorify thy holy Name, and finally by thy mercy obtain everlasting life; through Jesus Christ our Lord. *Amen.*

THE peace of God; which passeth all understanding, keep your hearts and minds in the knowledge and love of God, and of his Son Jesus Christ our Lord. And the blessing of God Almighty, the Father, the Son, and the Holy Ghost be amongst you, and remain with you always. *Amen.*

Most merciful Father] This Prayer is an adaptation of the "Benedictio super populum," by the newly-ordained Bishop, in the Salisbury Pontifical:—

"Deus, qui me indignum et peccatorem ad Pontificale officium dignatus est promovere, sua vos illustret atque sanctificet benedictione. Amen.

"Donet mihi per gratiam suam bene operandi facultatem: et vobis sui famulatus promptissimam obediētionem. Amen.

"Sicque vos doctrinis spiritualibus et operibus bonis replexi in præsenti vita concedat: ut ad pastua vitæ æternæ cum cæteris

ovibus suis vos pariter introducat. Amen."

A somewhat similar prayer is to be found in Assemani's collection [P. iii. pp. 55, 88, 89], at the delivery of the Episcopal ornaments, and in the Prayer of Consecration [P. iv. 165], Πόισον γίνεσθαι τοῦ Ἀληθινοῦ Ποιμένος, δδηγὸν τυφλῶν, φῶς τῶν ἐν σκότει, παιδευτὴν ἀφρόνων, φωστῆρα ἐν κόσμῳ, ἵνα, κατατίσας τὰς ἐμπιστευθείσας αὐτῷ ψυχὰς ἐπὶ τῆς παρούσης ζωῆς, παραστῆ τῷ βήματι τοῦ ἀκατασχόντως, καὶ τὸν μέγαν μισθὸν λήψῃται ὃν ἐταίμασας τοῖς ἀθλήσασιν ὑπὲρ τοῦ κηρύγματος τοῦ εὐαγγελίου, τοῦ.

FINIS.

GENERAL APPENDIX.

I.

THE "STATE SERVICES."

UNTIL the year 1859 modern editions of the Book of Common Prayer contained four services for special days of the year, which were commonly called "State Services," because they commemorated certain public events connected with the political history of the country; and because the use of them was enjoined by the State alone rather than by the Church and State together. These formed no part of the Book put forth by authority of Crown, Convocation, and the Houses of Lords and Commons in 1661, and therefore no part of the Book alone sanctioned by the Act of Uniformity¹. The authority for the three which have been discontinued was of a mixed character, partly civil and partly ecclesiastical; the authority for that which is still enjoined by the State is to this day solely that of the State, and of one branch of the State alone. In giving a short summary of the history and obligation of the several Forms, it will be convenient to mention the particulars of each case separately.

§ *The Form of Prayer for the Fifth of November.*

The Act of Parliament 3 Jac. I., cap. 1, provided for the annual observance of this day in commemoration of the discovery of the Powder Plot, and ordered that all ministers in every Cathedral and Parish Church should say Morning Prayer, and "give thanks to Almighty God for this most happy deliverance," and that all "persons inhabiting within this realm of England and dominions of the same" should resort to some Church and be present during such service. No particular form, however, was prescribed, and none was prepared by Convocation; but a form drawn up by the Bishops was issued by Royal authority in 1606. In April, 1662, this form was revised by Bishop Cosin, and adopted by Convocation on the 26th of that month, together with those for January 30, and May 29, and was attached to the Prayer Book by virtue of a Royal Proclamation, enjoining the use of all the three, of May 2, 1662. The form remained unaltered until the accession of William III., when, as he happened to have landed in England upon that day, and was regarded as the means of a similar deliverance to that then commemorated, various interpolations relating to his accession, as well as some alterations (e. g. the substitution of Luke ix. 51—57 as the

¹ At the end of the Printed Sealed Copies, the following is found in manuscript:—

"*The Formes of Prayer for the V of November, the XXX of January, & for the XXIX of May are to be printed at the end of this Book.*"

This notice was probably written by the Commissioners appointed to revise the standard copies [see p. xliii], but it is not found in the one manuscript of the Prayer Book which remains, that kept at Dublin, and it may be safely asserted that it had not the authority of the Crown, of Convocation, or of the Houses of Lords and Commons.

The history of the State Services themselves is fully given, from the two opposite points of view, in Rev. A. P. Perceval's "Original Services for the State Holidays," Lond. 1833, in which the original and altered Forms are exhibited in parallel columns, and in a pamphlet by Rev. T. Lathbury, "The Authority of the Services . . . considered," Lond. 1843.

Gospel, instead of Matt. xxvii. 1—10, the account of Judas's betrayal of his Master, "which for some good reasons, I suppose," says Wheatley, significantly, "was then thought proper to be discontinued") were made by Bishops Patrick and Sprat without the sanction of either Convocation or Parliament. This service was then re-issued by Proclamation of October 18, 1690, and was the form which continued to be enjoined until its recent removal.

§ *The Form of Prayer for the Thirtieth of January.*

This day was appointed to be observed "as an anniversary day of fasting and humiliation, to implore the mercy of God," by Act of Parliament 12 Car. II., cap. 30. The form of Prayer was prepared by a Committee of Convocation appointed May 16, 1661, which consisted of Bishops Warner of Rochester, King of Chichester, Morley of Worcester, and Reynolds of Norwich, together with eight representatives of the Lower House; it was approved April 26, 1662, and enjoined, with the preceding service, by Proclamation of May 2, 1662². Upon the accession of James II., however, certain alterations were made by royal authority alone, which were not improvements, intensifying in some degree the tone and language of the earlier service, and, especially, enlarging the introductory Hymn by the addition of various passages of Holy Scripture prophetic of our Blessed Lord's Sufferings and Death. This form (the order for the use of which was dated December 23, 1685) was not altered during the reign of William III., and was the one which remained in use subsequently.

§ *The Form of Prayer for the Twenty-ninth of May.*

The Act 12 Car. II., cap. 14, appointed May 29 to be observed with public thanksgivings for a double reason, as being the birthday of Charles II. as well as the day of his Restoration.

² It has not, we believe, been previously distinctly noticed that two editions and versions of a Form were issued "by His Majesty's direction," before that which was prepared by Convocation. One of these appeared in 1661, in which the introductory Hymn was longer than that in the subsequent service, some of the proper Psalms different, and a very long prayer, full of the strongest expressions, occupied the place of the first Collect, which, together with some portions of the other prayers, was taken from "Private forms of prayer, fitted for the late sad times; particularly a form of prayer for the thirtieth of January," a book in which Bishop Brian Duppa had a share, printed at London in 1660. By a singular oversight, the Collect for the Royal Family was copied without alteration from a Prayer Book of the reign of Charles I.; and consequently petition were offered in it for "Queen Mary, Prince Charles, and the rest of the royal progeny," when that Prince had become the reigning monarch. A second edition, corrected in this respect, appeared, with a proclamation for its use, dated January 7, 1662; it was somewhat curtailed, but was still longer than the Form finally adopted by Convocation. Burnet says that Sancroft drew for the three days "some Offices of a very high strain. Yet others of a more moderate strain were preferred to them. But he, coming to be advanced to the See of Canterbury, got his Offices to be published by the King's authority" (*Own Times*, i. 333). Probably these were the alterations introduced on James's accession.

The service was prepared, as in the preceding case, by a committee of Convocation, consisting of Bishops Wren of Ely, Skinner of Oxford, Laney of Peterborough, and Henschman of Sarum, together with eight members of the Lower House; its approval by the two Houses and issue under the authority of the Crown were simultaneous with those of the form for January 30. Since, however, various portions herein referred to the birth of Charles II., the use of which after his death would have been out of place, the form was revised upon the accession of James, who upon its re-publication issued an order for its observance, dated April 29, 1685, which mentioned the reason for its alteration, and stated that it was "now, by our special command to the Bishops, altered and settled to our satisfaction." From this time the form continued without any further change.

§ *The Form of Prayer for the Accession of the Sovereign.*

This is the only one for which there was never any degree of parliamentary authority, formerly or at present. The other services, although not specially prescribed, were recognized by the enactments which ordered that their several days should be observed with particular thanksgivings; but even this modified authority is wanting to the service for the Accession. In principle, however, it is the oldest of all the State Services. The first form was issued in 1578, to be used on November 17, the day of the accession of Queen Elizabeth; but during the reign of James I., the observance of the day appears to have been laid aside, his reign being sufficiently marked by the form for November 5, and that for August 5, the day of his escape from the conspiracy of the Gowries. A form, however, was issued in 1626 for the accession of Charles I., the history of the preparation of which is not known, but which appeared only under the King's authority. Among the Canons passed by Convocation in 1640 was one which recognized this form and enjoined the observance of the day; but an Act passed in 1661 (13 Car. II. cap. 12), expressly forbade the enforcement of these Canons, and the day and form alike remained unsanctioned, and were then disused, the King's accession being more fitly commemorated on May 29. But on the accession of James II. both were revived; a new form was prepared, which retained but one of the prayers in the previous form (that which commences, "O Lord our God, Who upholdest and governest"). It appeared with a proclamation for its use dated December 23, 1685, which sets out with stating, "Whereas not only the pious Christian emperors in ancient times, but also of late our own most religious predecessors, kings of this realm, did cause the days on which they began their several reigns to be publicly celebrated every year (so long as they reigned) by all their subjects with solemn prayers and thanksgiving to Almighty God; this pious custom received lately a long and doleful interruption upon occasion of the barbarous murder of our most dear Father of blessed memory, which changed the day on which our late most dear brother succeeded to the Crown into a day of sorrow and fasting. But now we thinking fit to revive the former laudable and religious practice, and having caused a form of prayer and thanksgiving to be composed by our Bishops for that purpose, our will and pleasure is," &c. During the reign of William III. the day and form were not observed, his accession being added to the service for November 5; but with Anne they returned into use, King James's service being revised and altered, and re-issued under the authority of a Proclamation of February 7, 1703-4. This remains the form still enjoined for use on June 20, the anniversary of the accession of Her present Majesty, except that during the reign of George I., part of the first lesson appointed in James's book (Josh. i. 1-9) was restored in place of the lesson substituted by Queen Anne (Prov. viii. 13-36).

From this brief summary it is evident that the three earlier forms had in their original condition sufficient authority; the days were appointed by Parliament for special services, such services were prepared by Convocation, and then were ratified by the Crown. The subsequent alterations lacked both parliamentary and ecclesiastical sanction, except in so far as the former was afforded by the recognition of the days and their services through the incorporation of the whole Prayer Book

Calendar, in the Act for the regulation of the Calendar, 24 Geo. II., cap. 23. Considerable difficulty was in consequence felt by many Clergy as to the legality of the forms, the reconcilability of their use with the terms of the Act of Uniformity, and the right of the State to impose them; added to which, the tone of portions of them jarred painfully in their bitterness and vehemence with that of the ordinary devotions of the Church. "Popish treachery," "hellish malice," "bloodthirsty enemies," and the like expressions, which were chiefly found in the form for November 5, were felt by most to be out of place in a service of solemn thanksgiving and intercession. In consequence, the observance of the several days gradually fell into comparative disuse, and was kept of late years only in Cathedrals, College Chapels, and in some (and some only) of the Churches where Daily Prayer was offered. The subject was considered in the Lower House of Convocation in 1857, and a Report from a Committee appointed to examine it (presented July 10), stated that the services as they then stood, with the alterations which had from time to time been made, rested on the sole power of the Crown. The mind of Clergy and Laity was therefore prepared to some extent for the debates in Parliament in June 1858 (in which special reference was made to the Report of Convocation) on the expediency of abolishing the observance of the three days, which resulted, in the first place, in Addresses to the Queen from both Houses, praying for the discontinuance of the Forms of Prayer. Upon these Addresses followed on January 17, 1859, the issue of the "Warrant" by Her Majesty, which ordered that the use of these forms "be henceforth discontinued," and that they "be not henceforth printed and published with, or annexed to, the Book of Common Prayer." The repeal of the several Acts enjoining the observance of the anniversaries (including also the Act of the Parliament of Ireland, 14 & 15 Car. II., cap. 23, for the observance in Ireland of the 23rd October in commemoration of the Rebellion of 1641) was then in the last place enacted by Stat. 22 Vict. cap. 2, which received the royal assent on March 25, 1859. It is, however, a matter for regret that the history of great national mercies and sins should by this total repeal have altogether lost its public religious aspect, in connexion with the teaching of the Church of the land; well would it have been if but one Collect for each day had been left by proper authority to preserve the memory and lessons of events which were of the highest national moment.

But if any doubt rested on the degree of obligation attaching to these three earlier forms, much more must it be a question how far the remaining service, that for the Accession, can still bind the Clergy to its use, when it rests simply and entirely upon the authority of Proclamation alone, without sanction from either Parliament or Convocation. Every true Christian Englishman who has a real sense of the dignity, greatness and responsibility of the Sovereign set over him by God, and a real interest in the welfare of the nation, must desire that the day which annually commemorates the perpetuity of our Constitution should be marked with a special offering of praise and prayer; praise for the great mercies vouchsafed to our land, and prayer that Prince and People may alike, from the consideration of those mercies, continually learn and practise better their own mutual duties. Greatly therefore is it to be wished that a form were prepared by Convocation and duly sanctioned by Parliament, in which all could gladly and without scruple take part; a form which would be indeed at once the annual solemn confession by the Church on behalf of the People that by God alone "Kings reign and Princes decree justice," and the annual witness to the old loyalty that jealously guards alike the Altar and the Throne.

OTHER SUPPLEMENTARY SERVICES.

§ *Service in Commemoration of the Fire of London.*

A Form of Prayer appointed to be used annually on September 2, in commemoration of the Fire of London (which commenced on that day), appears in some Oxford Prayer Books printed between 1681 and 1683. It was first issued for use, "by his Majesty's special command," on October 10, 1666, and contained, like other special forms, a hymn instead of the *Venite*, proper Psalms and

Lessons, &c.; but was without any special mention of the Fire or of the City of London. In 1696 it was revised and re-issued under Archbishop Tenison's authority, with a different hymn, and other changes, and with a Collect added which prayed for the preservation of the City from fire. The service was reprinted in a separate shape by the king's printers from time to time, even as lately as the year 1821: and a Latin version of it is included in the Latin Prayer Book published by Thomas Parsell, of which the last edition appeared in 1744. Its use was continued in St. Paul's Cathedral until the year 1859, when the observance of the day ceased, together with that of the state holydays abrogated by Parliament.

§ *The Office used at the Healing.*

Prayer Books printed in the earlier part of the last century, and particularly during the reign of Queen Anne, frequently contain the prayers used on the occasion of the touching by the sovereign for the cure of the king's evil. The earliest edition in which the office has as yet been found is of the date of 1707, and the latest is that printed by Baskett in Oxford in 1732 (*Bodl. Libr.*). A Latin version, however, continued to appear in the later editions of the Latin Prayer Book published by Thomas Parsell, of Merchant Taylors' School, to the year 1744. But as the service possessed no liturgical authority, and had no rightful place in the English Service Book, it is not necessary to notice it here in any detail. It was first, as it seems, compiled in a regular form in the reign of Henry VII., whose Office was printed by Henry Hills, the king's printer, in 1686, in quarto¹, and is to be found reprinted in Pegge's "*Curialia Miscellanea*," (Lond. 1818), and in vol. iii. of Maskell's "*Monumenta Ritualia*." The order of the service appears to have varied with each sovereign, and the ceremonial used by Queen Anne was considerably shorter than that adopted by her predecessors.

Although the service appears in Prayer Books of the Georgian era, it is said that it was never used by a sovereign of the house of Hanover. The power of touching was exercised by the son of James II. as James III. in the hospitals at Paris, and by Prince Charles Edward at Edinburgh; but it is not known whether the last representative of the house of Stuart, the Cardinal of York,

¹ This edition is in Latin, with English rubrics. An edition entirely in English was also printed by the same printer in the same year in duodecimo, of which a copy exists among Ant. & Wood's books in the Bodl. Libr., No. 893, iv.

ever claimed to use it, although two silver touch-pieces for distribution at the healing were struck by him as Henry IX.

An English form from a Prayer Book of 1710 is given, as well as the earlier Latin form, in Pegge's "*Curialia Miscellanea*," and from a Prayer Book of 1715 (also with the Latin form) in the Notes to A. J. Stephens' edition of the Prayer Book, vol. ii. pp. 990—1005, in both cases accompanied with notices of the rite; but the fullest historical account of the whole subject is to be found in a pamphlet by Edw. Law Hussey, Esq., M.R.C.S., of Oxford, reprinted in 1853 from the *Archæological Journal*, and entitled, "On the Cure of Scrofulous Diseases attributed to the Royal Touch."

The *Form of Consecrating Cramp-rings on Good Friday*, as a remedy against contraction of the nerves and the falling-sickness, — a practice used by Henry VIII. and Queen Mary, in the assertion of a similar power to that claimed to be exercised in the preceding rite, was never printed in the Prayer Book, as it was never used by any sovereign since the Reformation, although apparently revised and prepared for use in the reign of James II. It is printed in English (from a MS. of the latter date) in Pegge's "*Curialia Miscellanea*," and in vol. iii. of Maskell's "*Monumenta*;" a Latin form, prepared for Queen Mary in 1554, is to be found in Burnet, and in Wilkins.

§ *The Form used at the Meeting of Convocation.*

This Latin form was first printed in 1700 by the king's printer, and again in 1702, with the title, "*Forma precum in utraque domo Convocationis, sive Synodi Prælatorum et cæteri Cleri, seu Provincialis seu Nationalis, in ipso statim cujuslibet sessionis initio solemniter recitanda*." It is found in Parsell's Latin Prayer Book, of which the fourth edition appeared in 1727, and a later one in 1744; and, from thence, in Bagster's "*Liturgia Anglicana Polyglotta*," published in 1825. It consists of the Litany (which is said in the Upper House by the junior Bishop, and in the Lower by the Prolocutor) with a special supplication inserted after that for the Clergy, a prayer after that for the Parliament, and the following four Collects before the Prayer of St. Chrysostom, viz. that for St. Simon and St. Jude, the second for Good Friday, and those for St. Peter and for the fifth Sunday after Trinity. The form is reprinted in the "*Appendix to Perceval's Original Services for the State Holy Days*," pp. 102, 103.

W. D. M.

II.

THE SCOTTISH PRAYER BOOK OF 1637.

The Scottish "Service Book," as it was called at the time of its introduction, is alike interesting from the great names with which it is associated, from the calamitous circumstances of its first appearance, from its relation to the first Book of Edward, and from the influence which, in spite of its failure in Scotland, it exercised on the final revision of the English Book. A brief description of this Prayer Book—popularly, but incorrectly, called *Abp. Laud's*—is now presented to the reader.

To begin with its historic antecedents. A real Episcopacy—as distinct from what is known in Scottish history as the "*Tulchan Prelacy*"—was provided for Scotland by the consecration, in 1610, of Abp. Spottiswood, Bp. Lamb, and Bp. Hamilton, for the sees of Glasgow, Brechin, and Galloway. Spottiswood became Abp. of St. Andrew's in 1615: and in the same year he seems to have drawn up a list of the wants of the Scottish Church, among which was included the lack of a form of Divine Service [Grub's *Ecl. Hist. of Scotland*, ii. 305]. At that time Knox's "*Book of Common Order*" was used, along with extemporary prayer. In 1616, the General Assembly at St. Andrew's, under Spottiswood's presidency, agreed to the proposal (which King James had expressly supported), that an uniform order of Liturgy should be framed,

"to be read in all kirks on the ordinary days of prayer, and every Sabbath-day before sermon." "The King," says Mr. Grub, "certainly intended to pave the way for the introduction of the English Prayer Book," while many of the Ministers of the Assembly merely contemplated a book on the model of the "*Common Order*" [Grub, ii. 375]. James determined to accustom the inhabitants of Edinburgh to the presence of the English ritual (which he had once rudely and ignorantly satirized), by establishing it in the Chapel Royal at Holyrood, where, on Saturday May 17, 1617, it was for the first time performed with "singing of choristers, playing on organs, and surplices," in the King's own presence. A Celebration followed on Whitsunday, when Bp. Andrewes preached. The Dean of the chapel, Bp. Cowpar, at first declined to communicate kneeling: Laud, who was in attendance on the Court, gave offence by performing a funeral in a surplice; and it was evident that the example of the Chapel Royal would not be willingly followed by the Scottish kirks. One other public step was taken in James's reign—the promulgation, in 1620, of an Ordinal for Scotland—a very unsatisfactory rite, which ignored the Order of Deacons. But the King received from Abp. Spottiswood the draft of a Liturgy,

which he caused to be revised by Dean Young of Winchester, and then returned, with marks of his own, to Spottiswood [Lawson, Hist. Episc. Ch. i. 497].

Charles I., at his accession, resumed the project of a Scottish Liturgy, and carefully considered the book which his father had received. Rather more than a year after Laud's translation to the see of London—that is, in September, 1629—the Bishop (then just able to sit up after a severe illness) was visited by Dr. John Maxwell, one of the Edinburgh Clergy, who told him in the King's name that he was desired to communicate with some Scottish Bishops, including Abp. Spottiswood, concerning a Liturgy for that Church. "I told him," says Laud [Works, iii. 427], "I was clear of opinion that if His Majesty would have a Liturgy settled there, it were best to take the English Liturgy without any variation He replied that he was of a contrary opinion; and that not he only, but the Bishops of that kingdom, thought their countrymen would be much better satisfied if a Liturgy were framed by their own Clergy, than to have the English Liturgy put upon them; yet, he added, that it might be according to the form of the English Service Book." Laud replied, that if this were so, he would take no further step until he was able to see the King. This he did in October; Charles "avowed the sending of Dr. Maxwell, and the message," but acquiesced in Laud's opinion. "And in this condition," says Laud, "I held the matter for two if not three years at least." Maxwell, meantime, was the bearer of a Royal Letter to Archbishop Spottiswood, "pressing greater conformity to the Church of England." [Lawson, i. 449].

In June, 1633, King Charles was crowned at Holyrood; and Maxwell appeared among the prelates as Bishop-elect of Ross. A few days later, Laud preached in the Chapel Royal on the benefits of ecclesiastical conformity; and some thought that this would have been a favourable time for proposing the reception of the English Liturgy in Scotland. But it appears that in this summer—otherwise memorable for Laud's translation to Canterbury—Charles gave way to the urgency of some of the Scottish Bishops for a Liturgy of their own. They used not only the argument from national feeling, but another which would have great weight with the King and Laud: "that, if they did not then make the book as perfect as they could, they should never be able to get it perfected after" [Laud, iii. 343]. The King ordered an Episcopal committee in Scotland to prepare a Liturgy, and to communicate with Laud, who was commanded to give his "best assistance in this way, and work." "I delayed as much as I could," he says, "with my obedience, and, when nothing would serve but it must go on, I confess I was very serious, and gave them the best help I could" [Laud, iii. 428]. Bishops Juxon and Wren were to assist Laud. Charles, in the meantime, determined that nothing should be wanting for the due performance of the English ritual at Holyrood: in October, 1633, he sent orders for that purpose, one of which was, "that there be prayers twice a day with the quire, according to the English Liturgy, till some course be taken for making one that may fit the customs and constitutions of that Church." Laud also wrote repeatedly to Bishop Bellenden, Dean of the Chapel, exhorting him to preach "in his whites" on Sundays, and otherwise to see to the due order of the worship.

The compilation of the Scottish Liturgy appears to have occupied between two and three years. Of the Scottish prelates, some, as the Archbishop of Glasgow, were more or less indisposed towards the undertaking, others were decidedly favourable, as Lindsay of Edinburgh, who was afterwards denounced at the Assembly of Glasgow, as "a bower to the altar, a dedicator of churches," and even "an elevator at consecration;" Bellenden of Aberdeen, Whiteford of Brechin, and Sydsarf of Galloway, who was pelted in 1637 by female fanatics, and accused of Arminianism and Popery, and driven into exile, where, alone of Scottish Bishops, he survived until the Restoration. But the two chief compilers were Maxwell, Bishop of Ross, and Wedderburn, of Dunblane. In fact, if the book were to be called after any one man, it should be known as "Maxwell's Liturgy." He was a person of much practical energy, and very

obnoxious to the Scottish Puritans. As early as 1636, or earlier, he established the English ritual in his Cathedral of Fortrose, where he afterwards, for some time, upheld the Scottish; he was denounced in 1638, as "a bower at the altar, a wearer of cope and rochet," and as having "consecrated" Deacons. Wedderburn was a Scotsman educated at Oxford, had been intimate with Casaubon, and held prebends at Wells and Ely; Laud knew him personally, "wished him very well for his worth sake," and thought that although "a mere scholar and a book-man," he was certain to do good service, if "his heart" could be kept up. The Presbyterians denounced him as having, by lectures at St. Andrews, "corrupted divers with Arminianism," and left evidence "in all the nooks of the kingdom, of his errors and perverseness, having been special penner, practiser, urger of our books and all novations." As an orthodox theologian, he had objected to the inadequacy of the Ordinal of 1620, and he felt very strongly the desirableness of making the new Service Book more perfect, by conforming it in certain important points to Edward VI.'s first Liturgy; for Laud cites a note of his, to the effect that if the forms of administering the Sacrament be left as they stood in that Liturgy, "the action will be much the shorter; besides, the words which are added since, 'Take, eat, in remembrance,' &c., may seem to relish somewhat of the Zuinglian tenet" [Laud, iii. 357].

Archbishop Laud himself disclaims, and with perfect justice, the authorship of the Scottish Liturgy; but allows that he took a deep interest in, and prayed heartily for, its success. Again, he writes, "I like the book exceeding well, and hope I shall be able to maintain any thing that is in it, and wish with all my heart that it had been entertained there" [Laud, iii. 335]. We find him urging on the English printers, revising proofs, encouraging Maxwell, receiving his queries as to certain suggestions, and "notes" from Bishop Wedderburn, as to which he takes the King's pleasure, "sits down seriously" with Bishop Wren to consider them, remits them to Charles with remarks, receives back from him those which he has approved, and sends them to Wedderburn written in an English Prayer Book, April 20, 1636 [Laud, vi. 456]. One or two of the points which he takes, may illustrate the minute carefulness of his criticism. The Psalms cannot be well sung without a colon in the middle of each verse. As to the Offertory sentences, "we admit of all yours," but some others from the English Book are recommended in addition.—"God be thanked," he concludes; "this will do very well, and, I hope, breed up a great deal of devout and religious piety in that kingdom." He asks Wedderburn to send him a list of *desideranda* which would make the Liturgy still more perfect, whether the times will bear them or not: he may find some use for them. The King himself was eager and painstaking; having sanctioned a first draft of the book on September 28, 1634, he gave a royal warrant in April, 1636, for the revised form sent by Laud to Wedderburn; and most of Laud's alterations were written down in his presence. As early as September 30, 1633, Laud had urged Spottiswood to proceed strictly according to law, "because His Majesty had no intendment to do any thing but that which was according to honour and justice, and the laws of that kingdom" [Laud, iii. 429]. And he tells us that he ever advised the Scottish Bishops, both in the King's presence and at other times, both by word and writing, "to do nothing in this particular but by warrant of law," protesting that, as he knew not the Scottish laws, he must leave the manner of introducing the Liturgy wholly to them. "And, I am sure, they told me they would adventure it no way but that which was legal" [Laud, iii. 336].

The misfortune was, that some of the Scottish Bishops, as well as Charles I. himself, appear to have regarded as legal what to the Scottish nation seemed an intolerable excess of power. Spottiswood, if we may trust the report of his conversation with the Earl of Rothes, relied on royal prerogative as sufficient to warrant the introduction of the Liturgy, or indeed of any other ecclesiastical change [Lawson, i. 519]. But Maxwell took a higher line, to the effect that the Bishops, who "had the authority to govern the Church, and were the presentative Church of the kingdom," had as such concurred with the King

in introducing the Liturgy [Lawson, i. 511]. Maxwell on this occasion spoke of General Assemblies, as "consisting of a multitude;" whereas it is remarkable that Laud in his History expresses an opinion that "the Bishops trusted with this business went not the right way, by a General Assembly and other legal courses of that kingdom" [Laud, iii. 278]; and in letters to Strafford and Spottiswood, he speaks of the Bishops' "improvidence" in being too desirous to "do all in a quiet way," in not "taking the whole Council into consideration," "engaging" the lay lords, and "dealing with" the ministers. "The King," he writes, "ought to have dealt more thoroughly with the lords of the Council, and sifted their judgments" [Laud, vi. 555]; and he proceeds to impute treachery to one whom he had trusted; the Earl of Traquair: an imputation which Collier in his History repeats [viii. 114]. The gross mistake of publishing the Canons, which commanded the use of the Liturgy, before the Liturgy itself appeared, has often excited astonishment. The Canons were promulgated by letters patent, on the ground of royal prerogative in causes ecclesiastical, May 23, 1635, and published early in 1636. The Service Book was authorized by a royal warrant of October 18, 1636, and by an Act of the Scottish Privy Council, December 20, 1636. But although a new Ordinal, of which no copy is now supposed to exist, but which appears to have recognized the Order of Deacons, and to have had the form "Receive the Holy Ghost," appeared at the close of 1636 [Grub, ii. 368], the Service Book was not actually published until Lent 1637.

We may lay all due stress on the various instances of mismanagement in this memorable transaction; but if Charles I. had taken a moderate course, avoiding the display of high-handed authority and the appearance of English dictation, and laying the proposed book before the General Assembly and the Parliament, its chance of acceptance could not have been materially improved; although there might have been fewer outbreaks of fanatical wrath, fewer outrages in the name of religion¹. The book—although, as we shall see, not faultless—was, in fact, too good to be appreciated by a people so deeply alienated, as Mr. Grub observes [ii. 399], "from what had been the common heritage of Christendom for fifteen centuries." Bramhall, then Bishop of Derry, wrote to Spottiswood that the book was "to be envied, perhaps, in some things, if one owned all," and agreed with Dr. Duppa, afterwards Bishop of Winchester, that since the first six centuries there had been no such Liturgy; and Maxwell declared it to be "one of the most orthodox and perfect Liturgies in the Christian Church." But this, to the Scots, was no recommendation.

Passing by the disasters which followed the attempt to introduce it at Edinburgh, July 23, 1637, we proceed to take a survey of its contents:—

"Prefixed to it was the royal proclamation enjoining its use A preface followed, which made reference to the constant use of some prescribed order of prayer in the Church, to the desirableness of uniformity, and to the propriety of adhering to the English form, even as to some festivals and rites which were not yet received in Scotland" [Grub, ii. 382]. Then came some remarks on ceremonies, the order for the Psalms (which were taken from the Bible version) and the Tables of Psalms and Lessons. "The Lessons for Sundays are almost precisely identical with those in the Elizabethan Table of 1561 The same may be said of the Holyday Proper Lessons, except that some First Lessons are omitted, and a few unimportant substitutions" [Scottish Eccles. Journal, iv. 199]. By the King's express order (October 18, 1636), six chapters from Wisdom were appointed for three Saints' days, six from Ecclesiastics for three

¹ In the "Remains" of Dean Granville, of Durham, published by the Surtees Society (Part ii. p. 117), he states that on Holy Thursday, 1633, he had a conversation with Burnet, Archbishop of St. Andrew's, who, "sadly bewailed" the want of liturgical worship in Scotland, "as also that he had not at first, after the King's restoration, attempted to introduce the Liturgy of the Church of England, together with the Bishops: which he and the Bishops of Scotland were now convinced, they might have done with as little trouble as they did the other."

others. He also commanded that some names of Scottish Saints, especially those of royal blood, and some of the most holy Bishops (as David, Kentigern, Colman, Columba, Palladius, Ninian, Margaret), should be placed in the Calendar; no Lessons for ordinary days were taken from the Apocrypha; the space thus left being filled by a large increase of chapters from the Old Testament Canon. * Thus, instead of our four chapters from Leviticus, eight were prescribed; from Numbers, twenty-four instead of eighteen; from Ezekiel, twenty-eight instead of nine; and between November 22 and December 17, fourteen chapters from 1 Chronicles, and thirty-four from 2 Chronicles, two very important books passed over in our arrangement. Ecclesiastes was finished on July 27, and was followed by Isaiah. Jeremiah was begun on August 31; on Michaelmas-Day, which had no Proper Lessons, Ezekiel was begun at Evening Prayer; Hosea on October 19; and Malachi was finished November 22. Then, on December 17, the latter chapters of Isaiah were begun again, from the forty-seventh onwards; so that the sixty-sixth concluded the year, as in our course. The rubric before the Daily Office, ordered that the accustomed place of the church, chapel, or chancel, should be used, except it should be otherwise determined by the Ordinary; that chancels should remain as in times past; and that the "ornaments" of the Clergy should be such as should be prescribed by the King, according to the Act of Parliament in that behalf. The duty of saying the Daily Office, either privately or openly, was laid on the Clergy, "except they be hindered by some urgent cause; of which cause, if it be frequently pretended, they are to make the Bishop of the diocese, or the Archbishop of the province, the judge and allower."

In the Daily Office, the first sentence was, "Cast away from you all your transgressions;" and there were fewer sentences than in our book. The Confession was to be said by the people after or with the Minister. The "Presbyter" was to pronounce the Absolution, "standing up and turning himself to the people, but they still remaining humbly on their knees." This was a considerable improvement on the English rubric as it then stood, "the Absolution to be pronounced by the Minister alone;" and here we may observe a case in which the Caroline revisers of our own book looked to the Scottish Service Book, although they altered "Minister" into "Priest," avoiding (as they avoided some other faults) the concession to anti-Catholic prejudice implied by the substitution of "Presbyter." The "power and commandment" was said to be given to the Presbyters of the Church of God, the Ministers of His Gospel; but after "and His Holy Spirit," came a clause which might be interpreted in a sense which would favour Puritanism; "that we may receive from Him absolution from all our sins." The twenty-third Psalm was substituted for the Benedicite. "Presbyters and Ministers" were named in the third versicle before the Collects. The Collect for Clergy and People was called a prayer "for the holy Clergy." The second of our Ember Collects was placed before the Prayer of St. Chrysostom.

In the Athanasian Creed, one or two alterations were made in the English text; "He therefore that would be saved, let him thus think," &c. "So He who is God and Man," &c. Laud, writing to Wedderburn, April, 1636, had refused to allow any more emendations in this Creed. The Litany prayed for the governing of "the Holy Catholic Church universally."

There was a peculiar Collect for Easter Even, which has been the model of our present noble one, the work of the last revisers. It is:—

"O most gracious God, look upon us in mercy; and grant that as we are baptized into the death of Thy Son, our Saviour, Jesus Christ, so by our true and hearty repentance all our sins may be buried with Him, and we not fear the grave; that as Christ was raised up from the dead by the glory of Thee, O Father, so we also may walk in newness of life, but our sins never be able to rise in judgment against us, and that for the merits of Jesus Christ that died, and was buried, and rose again for us."

The Communion Office was in more ways than one indicative of Wedderburn's desire to return to the First Liturgy of Edward;

and "great need there was," said David Mitchell, afterwards for a few months Bishop of Aberdeen, "to return to it, *propter Sacramentarios*" [Lawson, i. 547]. Bishop Horsley's expressed admiration of the Scottish Communion Office, which is a revised form of the Office of 1637, is well known: he considered that it was decidedly better than the English Office of 1662, although the latter was "very good."

The introductory rubric ordered that the Holy Table (which was never spoken of in the Office simply as the Table) should have "a carpet, and a fair white linen cloth upon it, and other decent furniture, meet for the high mysteries there to be celebrated," and should "stand at the uppermost end of the chancel or church." The Presbyter was to begin "at the north side or end thereof;" our book has nothing about "end." He was to turn to the people when reciting the Commandments; a direction not given in England until 1662. An anti-Sabbatarian feeling expressed itself in the words, that the people were to ask God's mercy for their transgression of the Law, "either according to the letter, or to the *mystical importance* of the said Commandment:" and it is remarkable that the difficulty felt as to the prayer referring to the Fourth Commandment not only suggested this qualifying clause, but afterwards led many of the nonjurors to substitute the Evangelical summary of the Law, commonly called "the Short Law," for the Ten Commandments. Instead of "Have mercy upon the whole Church," the reading was, "Have mercy upon Thy Holy Catholic Church, and in the particular Church in which we live, so rule," &c.

It was expressly provided that the people should say, "Glory be to Thee, O Lord," at the announcement of the Gospel, and also "Thanks be to Thee, O Lord," at its end. The Nicene Creed was to be said or sung: this alternative was given in England in 1662. The Ofterory began with the account, in Genesis iv. 3, of Cain and Abel. The thanksgiving of David [1 Chr. xxix. 10, sq.] was one of the sentences; the Scottish Office, since the revision of 1755, has ordered it to be said at the moment of presenting the alms. There were no sentences from the Apocrypha. The alms were loosely called oblations (in the present English book a distinction is observed): and they were to be "humbly presented on the Holy Table," an order which our present book has adopted. There was another order for the "offering up and placing" of the elements upon the Lord's Table; and our present book has substantially adopted this also, and has a reference to the elements as "oblations" in the prayer, whereas the Scottish book had no such reference. The words "militant here in earth," were retained. Where we read, "all Bishops and Curates," the Scottish reads, "all Bishops, Presbyters, and Curates." At a Celebration these words were added: "And we commend especially unto Thy merciful goodness the congregation which is here assembled in Thy name, to celebrate the commemoration of the most precious Death and Passion of Thy Son and our Saviour Jesus Christ." The Liturgy of 1549 was not followed in its mention of the Blessed Virgin, the Patriarchs, Prophets, &c., nor in its commendation of the departed faithful to God's mercy; but other parts of the language of 1549 were adopted, the Prayer, after "any other adversity," proceeding, as now the Scottish form does: "And we also bless Thy holy Name for all Thy servants who having finished their

course in faith do now rest from their labours. And we yield unto Thee most high praise and hearty thanks for the wonderful grace and virtue declared in all Thy Saints, who have been the choice vessels of Thy grace, and the lights of the world, in their several generations; most humbly beseeching Thee that we may have grace to follow the example of their steadfastness in Thy faith, and obedience to Thy holy commandments; that at the day of the general resurrection, we, and all they which are of the mystical body of Thy Son, may be set on His right hand, and hear that His most joyful voice, Come, ye blessed of my Father, inherit the kingdom prepared for you from the foundation of the world. Grant this," &c. It is easy to see that the Caroline revisers had this before them when they framed the commemoration of the departed servants of God for the book of 1662.

The service then proceeded as it was settled in the Second Book of Edward, until the Preface: the word "blessed" being inserted before "Virgin" in the Christmas Preface. The Invitation, Confession, Absolution, Sentences, Preface, and Tensanctus were kept in the place which they held in the English rite, by Laud's desire; but the Prayer of Access was deferred until just before Communion. The rubric before consecration was:—

"Then the Presbyter, standing up, shall say the Prayer of Consecration, as followeth. But then during the time of consecration, he shall stand at such a part of the Holy Table, where he may with the more ease and decency use both his hands."

On this it is to be observed: (1) that Laud had expressly required that "every prayer or other action in the Communion should be named in the rubric, that it might be known what it was,—The Prayer of Consecration, the Memorial or Prayer of Oblation." And until 1662 the English book had no such words as "the prayer of consecration." (2) That from Laud's own words [Laud, iii. 347], and from the obvious sense of the passage, it is plain that the celebrant was intended to perform the consecration standing *in front* of the Holy Table. This was objected to in "Rome's Master-piece," as "smelling very strongly of Popery" [Laud, iv. 495]. In reference to such changes, Laud argues that "the north end of the table in most places is too narrow, and wants room, to lay the Service Book open before him that officiates, and to place the bread and wine within his reach." [Here again Laud allows the word "end" to stand for "side."] And (3) that this throws light on the present English rubric, which was clearly framed with the Scottish rubric in view; and discourages that interpretation of it which would have the Priest stand before the Table only while ordering, not while consecrating, the elements.

The actual Prayer is like our own until "Hear us," except that it reads "which" for "who" after "Father," and also inserts "and Sacrifice" after "precious death"—an insertion not taken from the Liturgy of 1549; then after the words, "beseech Thee," comes the Invocation, a passage of which Laud says [iii. 354]: "Tis true, this passage is not in the Prayer of Consecration in the Service Book of England; but I wish with all my heart it were. For though the consecration of the elements may be without it, yet it is much more solemn and full by that invocation." The form may be compared with those of Edward's First Liturgy and the present Scottish office.

e

First Book.

And with Thy Holy Spirit and word¹ vouchsafe to bless and sanctify these thy gifts and creatures of bread and wine, that they may be unto us the Body and Blood of Thy most dearly beloved Son Jesus Christ: Who in the same night . . .

And of Thy Almighty goodness vouchsafe so to bless and sanctify with Thy word and Holy Spirit these Thy gifts and creatures of bread and wine, that they may be unto us the Body and Blood of Thy most dearly beloved Son: so that we receiving them according to Thy Son our Saviour Jesus Christ's holy institution, in remembrance of His death and passion, may be partakers of the same His most precious Body and Blood: Who in the night . . .

1637.

Present Scottish.

And of Thy Almighty goodness vouchsafe to bless and sanctify with Thy word and Holy Spirit these Thy gifts and creatures of bread and wine, that they may become the Body and Blood of Thy most dearly beloved Son.

¹ It seems certain that by "word" is meant the words of institution.

It is remarkable that early in the eighteenth century, Bishop Rose of Edinburgh was accustomed, when using the English Office of 1662, to insert this Invocation: and it became one of the famous Usages. The present Scottish rite, since 1755, has placed the Invocation after the Oblation, and, since 1764, has omitted the Western phrase "to us," and the sentence, "so that we receiving," &c.

The English Office until 1662 had no directions for any "manual rites" in consecration. But the practice, as we infer from Laud's letter to Wedderburn, and from Cosin [Works, v. 340], was for the Priest to take the paten and chalice into his hands. But the Scottish Book prescribed all the four manual rites, just as the Book of 1662, evidently borrowing from it, has prescribed them. This is one of the most important instances of the beneficial effects of the Scottish Book on the Caroline revision.

After the words of institution came, "Immediately after this shall be said the Memorial, or Prayer of Oblation, as followeth:"

"Wherefore, O Lord and heavenly Father, according to the institution of Thy dearly beloved Son our Saviour Jesus Christ, we Thy-humble servants do celebrate and make here before Thy Divine Majesty, with these Thy holy gifts" [here the present Scottish Office, since 1743, has added "which we now offer unto Thee," an express oblation in this place being one of the greater "Usages," and ranking as such with the Invocation of the Holy Spirit, the mixed cup, and the non-exclusion, to say the least, of prayer for the departed¹;] "the memorial which Thy Son hath willed us to make; having in remembrance His blessed Passion," [the present Scottish adds, "and precious Death,"] "mighty Resurrection, and glorious Ascension; rendering unto Thee most hearty thanks for the innumerable benefits procured unto us by the same." [Here the present Scottish inserts the Invocation.] "And we entirely desire Thy Fatherly goodness," &c., as in our present book down to "humbly beseeching Thee," when following the book of 1549, it proceeded, "that whosoever shall be partakers of this Holy Communion may worthily receive the most precious Body and Blood of Thy Son Jesus Christ, and be fulfilled with Thy grace and heavenly benediction, and made one body with Him, that He may dwell in them, and they in Him. And although we be unworthy," &c., as in the present English. Then came the Lord's Prayer; Laud, it may be added, having thoroughly approved the placing of it and of the Prayer of Oblation before the Communion. Then the Prayer of Access; and then the Communion, the Bishop or the Celebrant being ordered first to receive, and then to administer to the other clergy, "that they may help him that celebrateth" (as it then stood in the English Book, "that they may help the chief Minister") "all humbly kneeling;" the English Book then had no such adverb; "meekly" was added in 1662. The benediction, "the Body of our Lord," &c. (which was much objected to by the Puritans, as suggestive of transubstantiation!) was to be said by the Celebrant himself when receiving, and to be followed by Amen; and the "Take and eat this," "Drink this," which had been first inserted in 1552, were, according to Wedderburn's request, omitted. Laud writes, "*I see, no hurt* in the omission of those latter words, none at all. And if there be any, it proceeded not from me." [Laud, iii. 357.]

After the administration, the Celebrant was to cover the remains of the Sacrament "with a fair linen cloth or corporal;" no such rule then existed in the English Book, but it was adopted—excepting the word "corporal," and with the addition of the word "reverently"—in 1662. The Collect, "Almighty and everliving God," then followed, as in the English Book; the strange error which from the First Book downwards had made this prayer, while addressing the Father, speak of "Thy mystical Body," was not corrected. The office was concluded by the Gloria in Excelsis and the Blessing. Among the rubrics after it there was a direction that after service what had been collected from the people should be divided

¹ Of these four usages the book of 1637 sanctioned only one, the Invocation.

in the presence of the Presbyter and churchwardens; half was to be for the Presbyter's use, "to furnish him with books of holy divinity;" half for purposes of piety and charity within the parish. There was also a careful provision,—which did not then exist in the English Book, but was adopted in 1662,—for the prevention of irreverent use of the consecrated remnants. To this was added: "And to the end there may be little left, he that officiates is required to consecrate with the least; and then if there be want, the words of consecration may be repeated again, over more either bread or wine; the Presbyter beginning at these words in the Prayer of Consecration: 'Our Saviour, in the night that he was betrayed, took,' " &c. This provision was also adopted, and made somewhat more definite, in 1662. The last rubric provided that every parishioner shall communicate at the least three times in the year, "of which Pasch or Easter shall be one; and shall also receive the Sacraments and other rites according to the order in this Book appointed." This, excepting the word Pasch, which was a peculiarly Scottish term for Easter, was then the language of the English Book; but the Scottish omitted the rule about parishioners reckoning at Easter with the parson, vicar, or curate, &c., and paying all ecclesiastical dues.

The only features in the Occasional Offices worthy of special notice are the following. In the first prayer at Public Baptism, before the entreaty that God would mercifully look upon these children, came the sentence, "Sanctify this fountain of Baptism, Thou which art the Sanctifier of all things." The First Book had placed this sentence, together with a signing of the Cross, in a Collect beginning, "O most merciful God, our Saviour Jesus Christ," which, with other prayers, was to be said after the water in the font had been changed, and before any child was baptized therein. Bucer had objected to this; "his fear was, lest it should engender the idea, that into the elements themselves, there was infused some magical efficacy" [Wilberforce on Holy Bapt., p. 247]. His objection, however unreasonable, had led to the omission of the benediction of the water in the Second Book; and the compilers of the Scottish Service Book resolved to return to the precedent of 1549, and to borrow from its elaborate benedictory office one sentence which should represent the idea, and might be inserted in the actual Order of Baptism. This was one of the points which gave great offence; it was a "consecration of holy water." And in the prayer before administration, "Almighty everliving God," which had stood at the end of the benedictory form of 1549, the reading was, "this water, which we here bless and dedicate in Thy Name to this spiritual washing." The Caroline revisers substantially imitated this, when they inserted the clause, "Sanctify this water," &c., into the latter of these two prayers.

The Commination address was to be heard by the people, "sitting and attending with reverence;" a direction not found in the English Book.

Such was the Service Book of 1637. Its history, to the thoughtful Churchman, is suggestive of much hope and comfort. After all the learned labour and devout solicitude bestowed upon it, after all the prayers made for its success, it comes forth associated with all that could most deeply prejudice the people of Scotland in its disfavour; it is made the occasion of sacrilegious outbreaks; it is spurned and denounced, with prayers that God would "confound" it; and it virtually kindles the first flame of civil war. Those who have been most heartily interested in it, have to mourn, as Laud did, over the failure of their hopes, and to prophesy that Scotland "will one day have more cause" than themselves for sorrow [Laud, iii. 338]. Bishop Wedderburn, driven, like most of the Scottish prelates, to seek a refuge out of Scotland, dies at or near Canterbury, in 1639 [Lawson, 611]. Bishop Maxwell, appointed by the King to Irish sees, plundered and wounded by Romanist insurgents, dies Archbishop of Tuam, February 14, 1646—being found lifeless on his knees; an end, surely, not unfitting for one who had so laboured to promote God's worship. Years pass away; the Restoration arrives, and the Church of England has to re-settle her Prayer Book. In this work, the ill-fated Scottish Prayer Book is unexpectedly and manifoldly influential; it assists the orthodox Caroline revisers to

raise the tone of the English Book, by various significant though gentle alterations, and in this way it materially strengthens the hold of Catholic belief and devotion on the hearts of the English race. In Scotland, indeed, the restored Church, for the most part, worships without a Liturgy; but when dis-established in 1689, after some years, it adopts from the Book of 1637 a Communion Office which, passing through several revisions, becomes the

known standard of a deeply earnest churchmanship, imparts one of its main features to the American rite, and may yet, in God's providence, do a work for Faith and Unity.

"Then I said, I have laboured in vain, I have spent my strength for nought, and in vain: yet surely my judgment is with the Lord, and my work with my God." [Isa. xlix. 4]. W. B.

III.

THE IRISH PRAYER BOOK.

The introduction of the Revised English Prayer Book into Ireland after the Restoration was effected not merely by Royal authority, or as an act of servile imitation and compliance, but as the result of deliberate and careful consideration on the part of the Convocation and Parliament of that kingdom. Among the MSS. of Archbishop King preserved in Trinity College, Dublin, is a volume containing the journals of the Irish Convocation in 1661—1665, from which it appears that in August and September the English book was examined by both Houses separately, and approved, the Lower House recommending the addition of Forms of Prayer for the Lord Lieutenant and for October 23. In November they resolved that an Act of Parliament should be asked for, enjoining the use of the Book on the Irish Church: but, from some unknown causes, the procuring such an Act was delayed for nearly four years¹. At length, on January 17, 1666, the Bill for Uniformity was read for the first time in the House of Commons; after the second reading, on February 1, it was referred to a committee, which reported that alterations were necessary in regard to dates which had already elapsed, and one or two other minor points. A new Bill was consequently introduced on May 18, 1666, which passed the House of Commons on May 22, and the House of Lords in due succession, and received the Royal Assent on June 18.

The English Prayer Book is therefore the Prayer Book also of the Irish Church by its own free adoption. But it contained, and still in a lesser degree contains, several additions which render it a distinct book, and which we now proceed to point out in brief detail².

I. In 1662 an Act of the Irish Parliament was passed (14 and 15 Car. II. cap. xxiii.) which ordered that October 23 be yearly kept as a day of thanksgiving for the discovery of the conspiracy to seize Dublin Castle and murder all the Protestants in 1641, which was revealed, as the Act states, not many hours before the time appointed for its execution, by Owen O'Connelly, "a meer Irishman," who had been brought up as a Protestant³. This Act ordered that Morning Prayer should be offered in all churches, without prescribing any particular form of thanksgiving; but on November 11 in the same year the Irish Convocation, in a declaration of acceptance of the revised English Liturgy, ordered that a new service be prepared for this day, as well as a Prayer for the Lord Lieutenant⁴.

Considerable delay ensued in the preparation of the form, and the execution of the necessary formalities for giving it legal

sanction, as well as in the extension of the Act of Uniformity to Ireland. In a letter from the Marquis of Ormonde, as Lord Lieutenant, to the Earl of Arlington, dated at Dublin, July 7, 1666 (preserved amongst Carfe's MSS. in the Bodleian Library, vol. li. p. 129) we read, "The Lord Primate [Margetsen] brought me the enclosed draught of a warrant for the King to signe, whereby certain prayers fitted for this kingdom are ordered to be added to the Booke of Common Prayer, which cannot be printed till his Majestie shall please to send the warrant signed." These prayers are consequently not found in the MS. Book of Common Prayer attached to the Irish Act of Uniformity, that Act having received the Royal assent on June 18, 1666, nor is October 23 mentioned there in the Calendar, in the list of "Certain solemn days." The warrant, however, for which the Primate asked was issued on August 15; and the service for October 23 consequently appears in the first Irish edition of the revised Common Prayer, which was published in the same year (1666), printed by John Crook at Dublin, in quarto⁵; although the service seems to have been added here after the rest of the volume (which was printed at different times) had been finished⁶.

On the accession of George I., all the State Services were revised by the Irish Bishops, for the sake of bringing them into accordance with the English altered versions of those which were in joint use, and the five (together with the prayers for the Lord Lieutenant) were then re-issued by a warrant from the King in Council, dated November 3, 1715.

This form retained its place in the Prayer Books in use in Ireland, (although since the Union it was not mentioned in the Order in Council prefixed to the State Services), until the discontinuance of the State Services in England, when the observance of the day was abrogated by the same statute which abolished three of the English State holidays, viz. 22 Vict. cap. 2., which received the Royal Assent, March 25, 1859. The abrogation, however, was not conducted according to the constitutional course which was followed with reference to the English offices. No Irish Convocation was summoned to consider the matter; and a Service which possessed the authority of the Church as well as of the State was abolished by being included in a bill which originally was contemplated only with regard to the three days, the disuse of the offices for which had been recommended by the English Convocation, and enjoined by Royal Warrant of 17th January, 1859, pursuant to previous addresses from the Houses of Parliament.

II. The Prayer for the Lord Lieutenant still used in the Daily Service, after that for the Royal Family, appears in the MS. Book of Common Prayer, but, strange to say, is omitted in the first printed edition. This appears to show that the earlier portion of that book was printed before the passing of the Irish Act of Uniformity to which the MS. was annexed. The prayer thus authorized by the three estates of the realm is the second of the two prayers which are printed in the present Irish editions, the first of these having been added (without any apparent reason)

¹ See "The Irish Convocation of 1661," an article [by Rev. J. C. Crosthwaite] in the "Irish Ecclesiastical Journal" for Dec. 1843, vol. ii. pp. 290—292.

² The original MS. of the Irish Book is fortunately still preserved in the Rolls' Office in Dublin; it was edited by Archibald J. Stephens, Esq., in 1849-50, in three vols. for the *Eccl. Hist. Soc.*, with full and elaborate historical introductions. A valuable sketch of the history of the Irish Book, by Rev. W. Keatinge Clay, B.D., is to be found in the "British Magazine" for Dec. 1846, pp. 601—629.

³ The observance of the day had been enjoined twenty years previously by "An Act of State made by the Lords Justices and Council of Ireland," Nov. 23, 1642, which was printed by Bladen at Dublin, at the same date. But the subsequent troubles had of course prevented the carrying out of this Ordinance. A copy of it is to be found in the King's Inn Library at Dublin, with the press-mark. N. 8. 16. [*Ex inform.* J. P. Prendergast, Esq.]

⁴ Stephens' *Introd.* to the Irish Prayer Book, vol. i. p. xc.

⁵ Only one copy of this edition is known to be extant, which was in the library of the late Earl of Charlemont. At the auction of that collection in 1865 it was sold for £5 10s., and is now in the British Museum.

⁶ Dr. Elrington in Stephens' *Irish C. P.*, vol. i. cxxiii., *British Magazine*, 1846, p. 619.

by the authority only of an Order of the King in Council, dated November 3, 1715. The following words, which originally formed part of the commencement of the other prayer, "by Whose will, providence, and Spirit powers are ordained, governments established, and diversities of administrations are dispensed," are found omitted in Prayer Books printed in 1700 and 1710, as well as in all later editions; an omission which probably commenced at the accession of William III.

A "praier for the Lord Deputie" is found in the earliest Irish Prayer Book, printed at Dublin in 1551, and is said to have continued in use, but with several variations, until the passing of the Act of Uniformity in 1666.

III. Another form peculiar to the Irish book is that "For the Visitation of Prisoners," consisting of three Offices, one to be used when "a prisoner is confined for some great or capital crime," another when "a criminal is under sentence of death," and a third "for imprisoned debtors." These were prepared in the Convocation held in Dublin in 1711, and were printed and annexed to the Prayer Book, "pursuant to Her Majesty's directions," by a warrant of the Lord Lieutenant and Council, dated April 13, 1714.

IV. "A Form of Consecration, or Dedication of Churches and Chapels, according to the use of the Church of Ireland," followed

by "An Office to be used in the Restauration of a Church," and "A Short Office for Expiation and Illustration of a Church desecrated or prophan'd" appears in the quarto edition of the Prayer Book printed by John Crook in 1700, and in subsequent folio editions printed by Grierson. These forms were reprinted from an edition printed separately by the former printer in 1666, but it is not known by whom they were prepared, or by what authority they were annexed to the Prayer Book. Although not now attached to the Book, the Form of Consecration is that which is still in use.

V. In the quarto edition of 1700 and the folio of 1721, the following unauthorized additions are also found: 1. "A Form for receiving lapsed Protestants, or reconciling converted Papists to our Church," which is said to have been written by Anthony Dopping, Bishop of Meath, and which was first printed separately in 1690; and 2. the Commemoration "Prayers for the use of Trinity College, Dublin." A Form of Bidding Prayer was prepared and enjoined by decree of Convocation of February 5, 1662¹; but it is not known how far its use was observed, or when it was discontinued.

W. D. M.

¹ Printed in Irish Ecc. Journ., *ubi supra*, p. 291, and Brit. Mag. xxx. 63.

IV.

ADDITIONAL NOTE ON THE LATIN PRAYER BOOK.

By an unfortunate oversight there is no reference at page xcix to a valuable Latin Version of our present Prayer Book, which was made by the learned and orthodox Dean Durel shortly after its settlement in 1662. The title-page of this Latin Prayer Book is as follows: "Liturgia, seu Liber Precum Communium, et administrationis Sacramentorum, aliorumque Rituum atque Cere- moniarum Ecclesie, juxta Usum Ecclesie Anglicanæ: unâ cum Psalterio seu Psalmis Davidis, ea punctatione distinctis, qua Cantari aut Recitari debent in Ecclesiis. Itemque Forma et Modus Faciendi, Ordinandi et Consecrandi Episcopos, Presbyteros, Diaconos. Londini, excudit Rogerus Nortonus, Reginus in Latinis, Græcis et Hebraicis typographus; vœneuntque apud Sam. Mearne, Regium Bibliopolarum in vico vulgariter dicto Little-Britaine, 1670."

There is some reason for supposing that this version was intended to be authorized as the standard Latin Book of Common Prayer, although no record remains of its being placed before the Convocation. Durel was Canon of Durham when he published it, having been appointed to his stall by Cosin, the principal Reviser of the Prayer Book, who had probably made his acquaintance during their exile when both were living at Paris. But for some years after the Restoration, Durel was Chaplain of the Savoy¹ and Deap of Windsor, the one post

¹ It was probably his connexion with the French chapel of the Savoy which led Durel to translate the Prayer Book into French. This version has been used ever since in the Channel Islands, though others of a Protestant character have also been introduced in modern times. The follow-

ing seems to associate him officially with the proceedings connected with the Restoration of the Church, and the other (as Confessor to the Sovereign) with King Charles II. Among Archbishop Sancroft's papers in the Bodleian Library there is also a letter from Durel submitting a specimen of his Latin version to the Primate for approval, and it is dedicated to the King in a very similar tone to that adopted by the last translators of the Holy Bible in their dedication of it to James I. These circumstances do not prove that Durel's Version had any actual authority given to it, but they seem to indicate that it was undertaken at the suggestion of men in high office and having great influence in ecclesiastical affairs; and it is not unlikely that further evidence may be discovered on the subject.

Dean Durel's Latin Version is a most excellent one, whether it is viewed as to scholarship, theology, or loyalty to the Church of England. The Psalms, Canticles, Epistles, and Gospels, are all printed from the ancient Salisbury Use; and the expressions of the latter are often followed, and even retained, in the Prayers, although most of these have been re-translated from the English.

ing is its title:—"La Liturgie, c'est à dire, Le Formulaire des Prières Publiques, de l'Administration des Sacraments, Et des autres Cérémonies et Coutumes de l'Eglise, selon l'usage de l'Eglise Anglicane, avec le Pseautier ou les Psaumes de David, Ponctuez selon qu'ils doivent estre ou chantez ou leüs dans les Eglises. A Londres: Pour Jean Dunmore et Octavien Pulleyn le Jeune à l'Enseigne du Roy en la petite Bretagne, 1667." Durel wrote several learned works, explaining the position, doctrines, and worship of the Church of England.

V.

ADDITIONAL NOTE ON THE LITANY.

At page 60, a suggestion is mentioned that "Son of David" was substituted for "Son of the Living God," in the latter part of the Litany, through some misunderstanding of the contracted form in which "Fili Dei vivi" was written. It has since been observed by Mr. Bright that "Jesu Fili David, miserere" . . . was a not uncommon expression in mediæval devotion.

In the book of records of University College, Oxford, there is

an entry to the following effect. "A composition twixt K. Henry VII. and y^e College concerning Dame Anne late Countess of Warwick, 8 H. 7. . . . and that the said Master, or any other Fellows of the said place that so shall sing the said high Masse in his stede that daye, shall devoutly remembre in his Masse these words in his second Memento: 'Jesu Fili David miserere animæ Famulæ tuæ Anne nuper Countesse Warwick' . . . and that

every poure scholer of the ten poure scholers founded by the charitable alms of the Founders of the said College shall say devoutly kneeling on their knees, betweene the Levation and the Reception of the most glorious and blessed Body of Criste, 'Jesu Fili David miserere Famulæ tuæ'

Similar words are also found in a Composition of a Benefactor to Magdalen College, Oxford, in the time of Henry VIII., "Jesu Fili David, miserere famuli tui Roberti." [Stat. Magd. Coll. Oxford, ii. 121.]

An interesting authority for the expression "all our sins, negligences, and ignorances," has also been discovered in an edition of

the Salisbury Hours of the Blessed Virgin, published at Paris in 1530. The following Suffrage is there directed to be used at the elevation of the Blessed Sacrament. "Sanguis tuus, Domine Jesu Christe, pro nobis effusus sit mihi in remissionem omnium peccatorum, negligentiarum, et ignorantiarum mearum." For this and one or two other additional illustrations of the Litany which are printed in the second edition of Part I., the Editor is indebted to the Rev. HENRY PHILIPPS, of Cheltenham, who has also contributed several valuable suggestions respecting the originals in some of the Occasional Offices.

VI.

ECCLESIASTICAL VESTMENTS.

In the Ritual Introduction to this Volume, Section III., a description is given of the *Material* and *Colour* of the "Ornaments of the Ministers" as anciently used by the Church of England in common, for the most part, with the Eastern and Western Communions. A few observations are here added as to their *Form*, in order to give a more distinct idea of their character than is conveyed by the mere names which designated them in the various documents there referred to, and to furnish an explanation of the Illustrations given in the accompanying Plates. As, also, the restoration of these Ornaments in many churches is constantly giving rise to inquiries about their signification, it is desirable to state the symbolical meaning involved in their use. The latter was done by authority so late as the year 1541-2 (only seven years before the publication of the First Prayer Book of K. Edward VI., and at the very time when the Convocation of Canterbury was revising the old Service Books) when there was drawn up, by Archbishop Crammer or under his direction, a "RATIONALE" of the "Ceremonies to be used in the Church of England, together with an Explanation of the Meaning and Significancy of them." [Collier, *Ecl. Hist.* vol. v. pp. 104-122, ed. 1852.] The descriptions given of the Vestments in this document are limited to those worn by the *Celebrant* himself, but they sufficiently indicate the importance attached to the Ministerial Ornaments; for the *Rationale* says that "The Priest . . . puts upon him clean and hallowed Vestments, partly representing the Mysteries which were done at the Passion; partly representing the Virtues which he himself ought to have that celebrates the Mass."

The Vestments mentioned in the *Rationale* are the following:—1. the Amice; 2. the Albe; 3. the Girdle; 4. the Stole; 5. the Phanon, i. e. the Maniple or Sudarium as it was also called; 6. the Chasuble. The Rubric in the Prayer Book of 1549 specifies only, 1. the Albe; 2. the Vestment or Cope; 3. the Tunicle; but, of course, it does not exclude the others named in the *Rationale*, and in fact the whole were in use under the First Prayer Book. These two lists, then, comprise eight Ornaments which are now to be described.

1. The AMICE, *Amictus* (the Armenian *Vakass* and, perhaps, the Eastern *Omophorion* seem to correspond to this, especially the former).—This is a broad and oblong piece of Linen with two strings to fasten it: in its more ornate form it is embroidered on the outer edge with a rich fillet or otherwise adorned. When used it is first placed on the head, then slipped down to and worn on the shoulders beneath the Albe; so that, when left somewhat loose, it has the appearance of an ornamental collar as shown in the drawing, Plate II.

The *Rationale* says—"He putteth on the Amice, which, as touching the Mystery, signifies the veil with the which the Jews covered the face of Christ, when they buffeted Him in the time of His Passion. And as touching the Minister, it signifies faith, which is the head, ground, and foundation of all virtues; and therefore, he puts that upon his head first."

2. The ALBE, *Alba* (the Eastern *Stoicharion* and the Russian *Podriznik*).—This is a loose and long garment coming down to the feet and having close-fitting sleeves reaching to the hands. Anciently it appears to have been made usually of Linen, though in later times rich silks of different colours were frequently used, while in the Russian Church velvet is often employed. It was very commonly ornamented with square or oblong pieces of Embroidery called *Apparels*; these were stitched on or otherwise fastened to various parts of it, especially just above the feet and near the hands, where they had somewhat the appearance of cuffs. The Rubric of 1549 directs the use of "a white Albe plain;" this may have meant a Linen Albe without *Apparels*, yet Silk or similar material seems not to be forbidden provided it be white: Embroidery, such as shown in the sketch; Plate I., appears sufficiently "plain" to be consistent with the language and intention of the Rubric. Old-fashioned Surplices are always thus ornamented about the shoulders, a tradition of ancient custom.

The *Rationale* says of the Minister that "he puts upon him the Albe, which, as touching the Mystery, signifieth the white garment wherewith Herod clothed Christ in mockery when he sent Him to Pilate. And as touching the Minister, it signifieth the pureness of conscience, and innocency he ought to have, especially when he sings the Mass."

The SURPLICE, *Superpelliceum*, Plate II. (whether with or without Sleeves) and the ROCHET, *Rochetum*, being both of them only modifications of the Albe, this language of the *Rationale* respecting it appears to apply equally to them.

3. The GIRDLÉ, *Cingulum* (the Eastern *Poyass*).—This is a Cord or narrow Band of Silk or other material (usually white) with Tassels attached; or, as in the Eastern Church, a broad Belt (often of rich material) with a clasp, hooks, or strings. It is used for fastening the Albe round the Waist.

The *Rationale* thus explains it:—"The Girdle, as touching the Mystery, signifies the scourge with which Christ was scourged. And as touching the Minister, it signifies the continent and chaste living, or else the close mind which he ought to have at prayers, when he celebrates."

4. The STOLE, *Stola* (the Eastern *Epitrachelion* of the Priest, the *Orarion* of the Deacon, the *Lention* of the Sub-deacon).—This is a strip of Silk about three inches wide, and about eight and a half feet long; it may be plain or richly ornamented; especially at the ends, of which examples are given in Plate II. The Priest wears it hanging over his neck, and when he celebrates it is usually crossed on the breast and passed under the Girdle: the Deacon wears it suspended over the left shoulder; but, when assisting at the Celebration, he often has it brought across his back and breast and fastened at his right side. As used by the Greek Priest it has the appearance of two Stoles joined together, the upper end having a hole through which the head is put, and thus it hangs down in front.

The *Rationale* says thus of it:—"The Stole, as touching the Mystery, signifieth the ropes or bands that Christ was bound with to the pillar, when He was scourged. And as touching the Minister, it signifieth the yoke of patience, which he must bear as the servant of God."

5. The MANIPLE, *Manipulus*, sometimes called *Fanon* or *Phanon* and *Sudarium* (the Eastern *Epimanikia* and the Russian *Pórutchi*; each of these are, however, a kind of Cuffs worn on both hands).—Originally it appears to have been a narrow strip of Linen, usually as wide as a Stole and about two and a half feet long [see Plate II.], and seems to have been employed as a kind of Sudarium for wiping the hands and for other cleanly purposes, whence it probably took one of its names. Subsequently, however, it became a mere ornament, being made of rich materials and often embroidered, or even enriched with jewels. It hangs over the left arm of the Celebrant and his assistants; it should be fastened near the wrist, in a loop, to prevent its falling off.

The *Rationale* describes its meaning together with the Stole in these words: "in token whereof" (i. e. of patience) "he puts also the Phanon on his arm, which admonisheth him of ghostly strength and godly patience that he ought to have, to vanquish and overcome all carnal infirmity."

6. The CHASUBLE or VESTMENT, *Casula* (the Eastern *Phelonion* and the Russian *Phelóné* or *Phalonion*).—This vesture is worn over the Albe: originally it was nearly or entirely a circular garment, having an opening in the centre through which the head of the wearer passed; and thus it fell gracefully over the shoulders and arms, covering the entire person in its ample folds and reaching nearly to the feet both before and behind: at a later period it was made narrower at the back and front by reducing its circular form, and so it frequently terminated like a reversed pointed arch; the sleeve part also became shorter, reaching only to the hands and thus avoiding the need of gathering it up on the arms. Ultimately, whether from economy, or bad taste, or supposed convenience, the sleeve parts were cut away to the shoulders in the Latin Communion; and even the Russian vestment has been so much reduced in the front that it covers little more than the chest: however, the older form has been for the most part retained in the rest of the Eastern Communion. The drawing on Plate I. shows the form which prevailed in the Church of England prior to the Reformation; it has the merit of being both elegant and convenient. The same picture shows the mode of ornamenting it, namely, by embroidering the collar and outer edge, and by attaching to it what is called the Y Orphrey; though very commonly the Latin Cross, and sometimes the Crucifixion, was variously embroidered on the back, only the perpendicular Orphrey (or Pillar, as it is termed) being affixed in the front.

The *Rationale* is thus given:—"The overvesture, or Chesible, as touching the Mystery, signifieth the purple mantle that Pilate's soldiers put upon Christ after that they had scourged Him. And as touching the Minister, it signifies charity, a virtue excellent above all other."

7. The COPE, *Cappa* (the Armenian *Phelonion* is a similar Vestment and is used instead of the Chasuble).—It is a kind of full, long Cloke, of a semicircular shape, reaching to the heels, and open in front, thus leaving the arms free below the elbows. Most commonly it has a Hood, as shown in the drawing, Plate II.; where also is represented the Orphrey and an illustration of the mode of enriching the material by embroidery. The mode of fastening it, by a *Band*, to which is often attached a rich ornament, called the *Morse* is there also exhibited. It is worn over either the Albe or the Surplice.

The *Rationale* does not mention it; probably because it was not one of the Eucharistic Vestments then or previously in use. But that it might be used at the Altar (though probably not by the Celebrant when consecrating the Oblations) is plain from the fact that the Rubric of 1549 in naming "Vestment or Cope," apparently allows a choice between it and the Chasuble; but it may only have been intended that, in a place where both are provided, the Chasuble alone should be worn where the whole Eucharistic Service was used; for a Rubric at the end of the Service specifies the *Cope* as the Vestment to be employed at those times when only the earlier portion of the Service is intended to be said, no *Consecration* being designed because of its being known that there would "be none to communicate with the Priest." The 24th Canon of 1603 does indeed recognize the Cope as the Celebrant's Vestment to be used in Cathedrals; but the Rubric of 1662, having later and larger authority, seems to point to the Chasuble of the Book of 1549 as the Vestment in which to consecrate.

8. The TUNICLE, *Tunica*; also called, as worn by the Deacon or Gospeller, DALMATIC, *Dalmatica* (the Eastern *Stoicharion* or *Saccus* of the Deacon).—This is a kind of loose coat or frock, reaching below the knees, open partially at the lower part of the sides; it has full, though not large, sleeves; in material and colour it should correspond with the Chasuble. Examples of its Orphreys and of the mode of embroidering it are shown in the two illustrations on Plate I. The Deacon's Dalmatic was usually somewhat more ornamented in the Western Church than was the Tunicle worn by the Sub-deacon or Epistoler.

This Ornament, like the Cope, is not mentioned in the *Rationale*, probably because, as was observed above, only the Vestments of the Celebrant are there specified.

T. W. P.

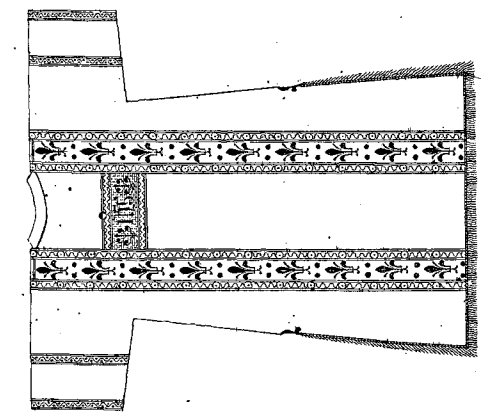

LONG DALMATIC.

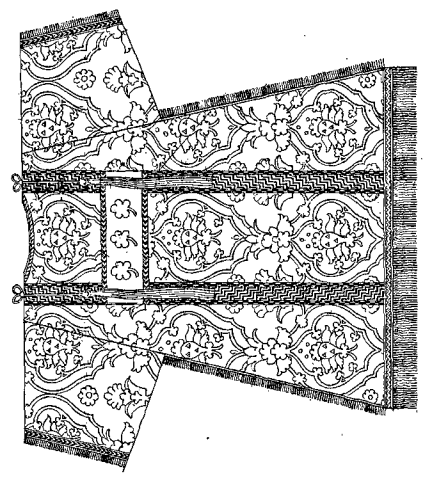

SHORT DALMATIC, 15th CENTURY.

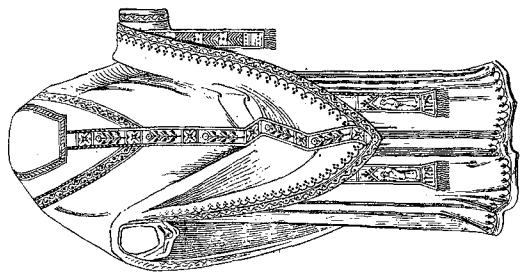

SKETCH SHEWING CHASUBLE &c. IN USE.

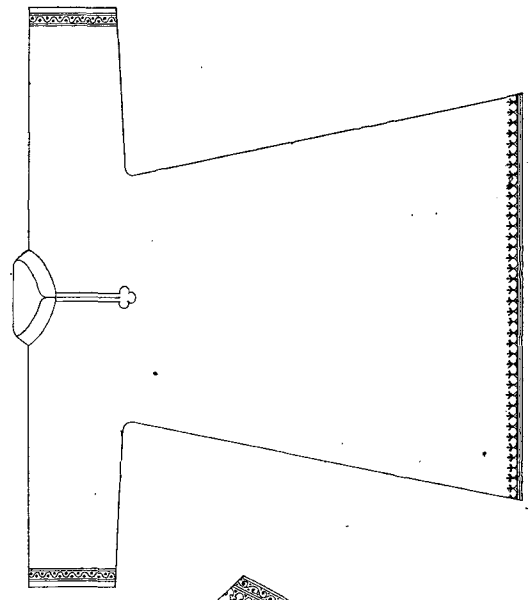

ALB.

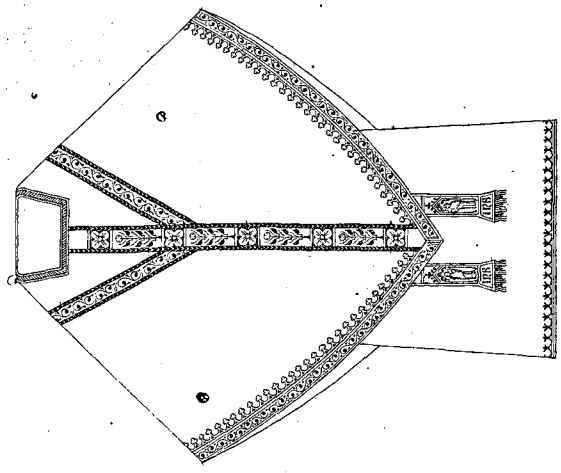

FRONT OF CHASUBLE WITH STOLE, AND ALB.

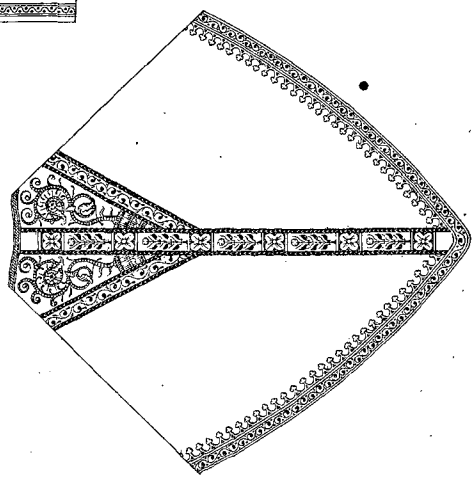

BACK OF CHASUBLE.

Scale markings: 1, 2, 3, 4, 5, 6, 7, 8, 9, 10, 11, 12, 13, 14, 15, 16, 17, 18, 19, 20, 21, 22, 23, 24, 25, 26, 27, 28, 29, 30, 31, 32, 33, 34, 35, 36, 37, 38, 39, 40, 41, 42, 43, 44, 45, 46, 47, 48, 49, 50, 51, 52, 53, 54, 55, 56, 57, 58, 59, 60, 61, 62, 63, 64, 65, 66, 67, 68, 69, 70, 71, 72, 73, 74, 75, 76, 77, 78, 79, 80, 81, 82, 83, 84, 85, 86, 87, 88, 89, 90, 91, 92, 93, 94, 95, 96, 97, 98, 99, 100. Feet.

ECCLESIASTICAL VESTMENTS.

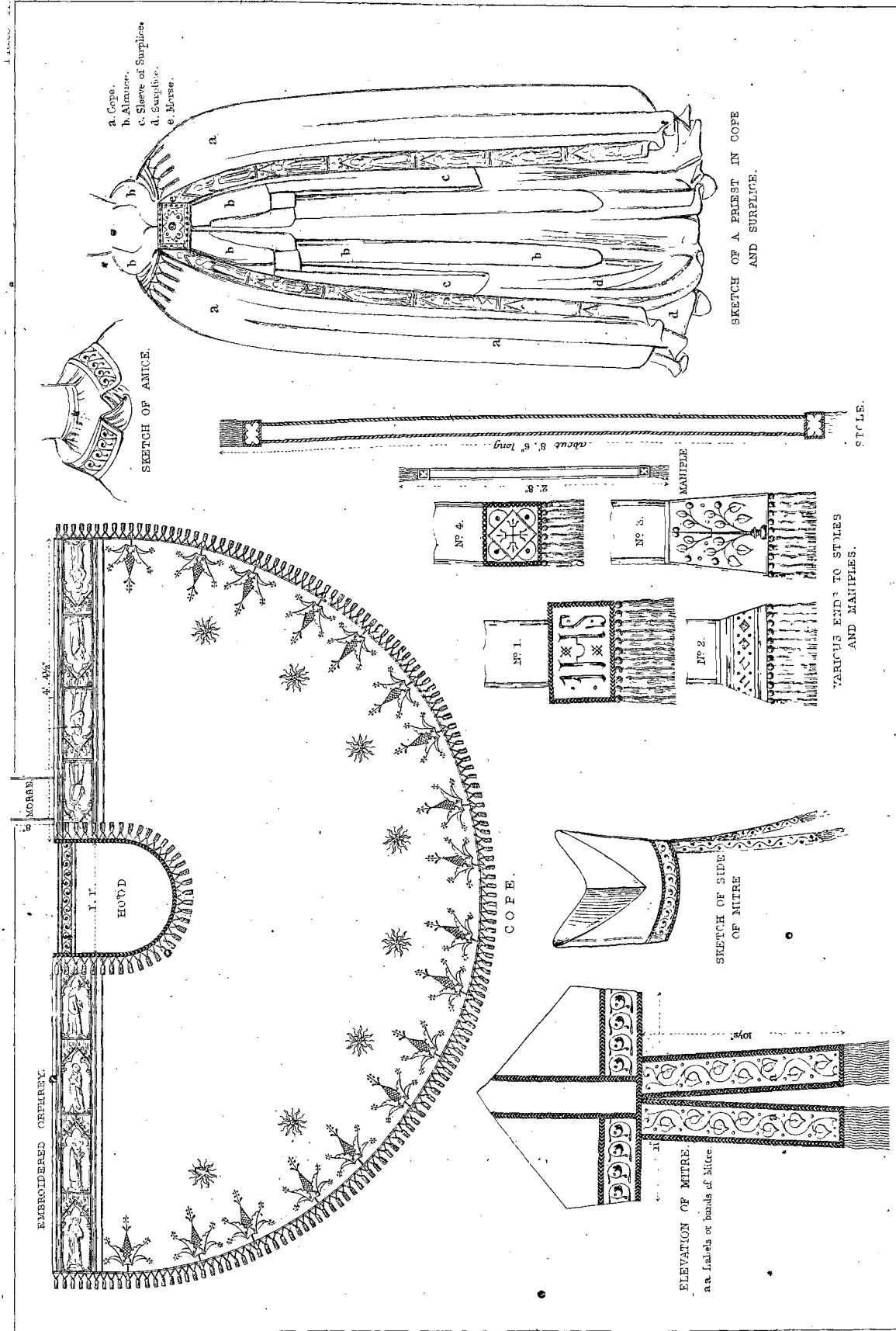

Drawn by George Edmund Street, F.S.A. A.R.A.

Published by Rivington, for The Annotated Book of Common Prayer.

HECLESIASTICAL VESTMENTS.

Herbert Broth, Ltd. London.

INDEX AND GLOSSARY.

- Abgarns, King of Edessa, his cure and conversion, 180.
- ABLUTION**, the rinsing of the Chalice after the Celebration of Holy Communion. It is done with wine and water, which are reverently drunk by the Priest. [See sixth Rubric after Communion Office.] 198.
- Abolition of early Liturgies of Europe, 147.
- ABSOLUTION**, the priestly act whereby the pardon of God is conveyed to penitents. Also the form of words employed.
- Absolution in Communion Office, 177; in Mattins and Evensong, 4. 177; Manual Sar. on, 285, n. 1; of Sick, 284; power of, when first stated, 539. 563; form of conveying power of, 563.
- ABSTINENCE**, a less rigorous kind of Fasting.
- Accession Service, [29]. 414. 579.
- Accessories of Divine Worship, Comparison of Rubrics, lxvi; the Reformers' standard in the time of Elizabeth, lxvi.
- "Accustomed duty" to Priest and Clerk, 268.
- Act authorizing drawing up of the English Ordinal, 535; same repealed, 536; authorizing use of Ordinal 1566, 536.
- Act of Uniformity, 1 Eliz., [4]; what it empowers the Sovereign to authorize, [2]; 13th and 14th Charles II., lxix.
- Act 5 Geo. IV., Omission of Burial Office, 293.
- Act 22 Vict., repealing the State Services, 579.
- Acta Sanctorum, 36.
- Acts of Queen Mary repealed, [4].
- Admission of Catechumen, how represented in our Office, 217.
- Admonition before Marriage, 264.
- Adoption included in New Birth, 214.
- Adullam, Cave of, 393. 515.
- Adults, Baptism of, 236.
- Advent "O Sapientia" Antiphon, 76; Ember days, 75; First Sunday—what is represented, 73; Fourth Sunday—alteration in the Collect, 75; general principle of its observance, that of our own Church, 73; how kept in the Eastern Church, 72; how observed anciently by the "Religious," 73; Hymns, to be sung daily up to Christmas Eve, 73; its observance primitive under another name, 72; said to be instituted by St. Peter, 72; observed as a Lent, 72; Rule for finding, [27]. 73; Epistles and Gospels for Wednesdays and Fridays, 73; as a preparation for Christmas, 73; Second, events preceding it, 450; period of, 445.
- Advents of the Lord, 383.
- Advertisements and Injunctions of Q. Elizabeth, lxvi, lxvii.
- Ælfric, Injunctions on vernacular teaching, xxiii; Canons of, on Communion of Sick, 289.
- AFFUSION**, the pouring of the water on recipients of Holy Baptism. [See **IMMERSION**.]
- Affusion, Baptism by, 211. 226.
- "After," its Liturgical sense, 3.
- Agatha, St., [41].
- Age, Canonical, for Ordination, 541. 544.
- Agnes, St., Benediction of lambs at her Church, [39]; touching saying of St. Augustine, [39].
- Aholiab, his inspired wisdom given for Ceremonial Worship, xlvi.
- Aidan, St., 37. 43.
- AISLE**, the side or wing of a Church, separated from the Nave by the arcade, i. e. the piers and arches.
- ALB**, or **ALBE**, the white linen robe worn by the Priest and his assistants at the celebration of Holy Communion. [See Ecc. Vestments, Plate I.]
- Alban, St., the first recorded British Martyr, [49].
- Albanopolis, Martyrdom of St. Bartholomew, 140.
- Aleuin, Quotations from, on Candlemas, 131.
- Alderson, Baron, on publication of banns, 262.
- Aless, Translator of the Prayer Book into Latin, xxx.
- Alexandria, St. Mark martyred there, 134; catechetical school of, 241; Liturgy of, 146; use of "Missæ Sicca" at, 197.
- Alexandrine Manuscript and the Te Deum, 11.
- All conditions of men, Prayer for, its authorship and intention, 65.
- "All holy Martyrs" festival, 114.
- All Saints' festival, 143; Sarum Psalms, 339. 359. 377. 423. 432. 435. 446. 459. 483.
- Allegation of impediment at time of Marriage, 265.
- Allegiance, Oath of, required of Bishops in Greek Church, 569.
- Allegiance and Conformity, Declaration of, in A. of Unif., 8.
- "Alloweth," old word for "approves and accepts," 220.
- Almanacks, Prohibited times for Marriage in, 263.
- Alms, Offering of, 174.
- Alphabet Psalms, 477, 478. 486.
- Alphege, St., [45].
- ALTAR**, the "Table of the Lord," whereon the Christian Sacrifice of the Eucharist is offered to God.
- Altar, a term properly applied to the Lord's Table, 158. 164; early names for, 158; of stone or wood, 158; wooden in Eastern Church, 158; in private house, 290; its position and decorations in primitive times, 159; of St. Peter at Rome, 158; of St. Cuthbert at Durham, 158; the, seen by St. John, its arrangement, xlix; rails, 165.
- Alterations at the Revision of 1559, xxxiv; Alterations in 1661—principles on which the Convocation acted, [13].
- Amalarjns, his use of the Benedictus, 16.
- Amalgamation of Offices for Private and Public Baptism, 234.
- Ambrose and Augustine, SS., and the Te Deum, 10.
- Ambrose, St., on Amen after Prayer of Consecration, 189; on Benediction of Water, 224; on burial, 295; case of private celebration, 290; on Confirmation, 251; tradition respecting him, [45]; excommunicates the Emperor—introduced Metrical Hymns, [45]; his influence over Western Church Music, lvii; his writings—contests with Heresy—saying attributed to him, [45]; on Marriage, 261; on Prayer of Invocation in Confirmation, 257; on trine immersion, 211; what he says of the Psalms, 316.
- Ambrosian Rite, 45, 46. 147.
- Amen, after Lord's Prayer, 6; after Prayer of Consecration, 188; on receiving consecrated elements, 190.
- American Church, Burial Office of, 299; Prayer Book, xlv; Prayer Book, its variations from that of England, xlv; Liturgy *in extenso*, 206; Liturgy referred to, 151. 167. 170.
- Amphibalus sheltered by St. Alban, [49].
- Ampulla of St. Remi, at Rheims, [57].
- Anabaptism, its growth during the Great Rebellion, [14]; rendered baptism of Adults necessary, 236.
- Anabaptist heresy protested against, 220.

- ANAPHORA**, the most solemn portion of the Eastern Liturgy, beginning with the *Sursum Corda*, and including the Consecration, 148.
- Ancient Customs in Baptism, 217. 221.
- Ancient English Collects, 38. 64. 113. 115. 133. 141.
- Ancient English Exhortation at Communion, 178; at Baptism, 229.
- Ancient English Questions and Exhortations in Communion of Dying, 292.
- Ancient English version of Nicene Creed, 169.
- Ancient English versions of Lord's Prayer, 31; of Apostles' Creed, 36.
- Ancient Form of Confession, Misereatur, and Absolution, 5.
- Ancient Offices for Churching of Women, 304.
- Ancient precedent for the Thanksgiving after Baptism, 228.
- Andrew, St., affecting words at his crucifixion, 129; his Festival, his History, 129; his labours and martyrdom, 129; patron of the Scotch and Russian Churches, 129.
- Andrewes, Bishop, on catechizing, 243; on Churching of Women, 305; on Eucharistic Commemoration of Departed, 192, 193; on the Absolution, 4; suggestion as to the sentences, 1; on meaning of *κατηχέω*, 241, n. 1; on Offerings at Churchings, 306; quotation, 51; used Wafer Bread, 198.
- Angel, primitive name for Bishops, 531.
- Angelic Hymn, 194.
- Angels, why commemorated, 141; their names, 141; their presence at Holy Eucharist, 184.
- Anglican Communion, aspect of, towards the rest of Christendom, lxxx.
- Anne, St., mother of Blessed Virgin Mary, [51].
- Annotine Easter, 107.
- Annunciation, The, mentioned by many of the earliest writers, 133.
- ANONING OF THE SICK**, an Apostolic practice of which Extreme Unction is declared in the Articles to be a "corrupt following." [See Visitation of the Sick.]
- Anointing at Baptism in Sarum rite, 227, Orig.; P. B. of 1549, 227, n.; Office of 1549 for, 237; Oil, 373.
- Anselm, St., "I put Thy precious passion," &c., 292.
- "Answer" of all the people, 8.
- ANTHEM**, a musical composition sung after the Third Collect at Mattins and Evensong. The term used to be applied to the Canticles. [Rubr. before *Venite exultemus*.]
- Anthem, Form of the word, in various languages, lxii.
- Anthem or Hymn, valuable Auxiliaries, lxiv; how they may popularize Church doctrine, lxiv; should respond to the service of the day, lxiv.
- Anthem, in Bur. Office, 297; in Vis. of Sick, 277; its proper place in the Service, lxiii; not rubrically recognized till 1661, lxiv; Synonym for Antiphonal, of Responsive Music, lxii; to what we owe the modern ones, lxii.
- Anthems, in the injunctions of Edward VI., xxvi.
- Antihymn*, mistake of Barrow and Johnson, lxii.
- Antichrist, instrument of the Evil One, 514; City of, 382; Church of, 400; final contest with him, 420, 421; ten kingdoms of, 435; Antichrist prefigured by Sehon, Og, &c., 509; subjugation of, 328. 447. 449. types of, 387.
- Antichristianism, a compromise, 331.
- Antioch, a great intellectual and theological Centre, lvi; its early Church Singing and Music, lvi.
- Antiphon of the Litany, 422; at burials in Mediæval Ch. 297; *Salvator mundi* in Vis. of Sick, 286; *Ne reminiscaris* in Vis. of Sick, 277.
- Antiphonal Singing, its early introduction, lvi; structure of Psalms, 506.
- Antiphons as examples of the use of Holy Scripture in Acts of Adoration, 76; for third and fourth weeks in Advent, 76.
- Anti-ritual party, 1564-65, Remonstrance of the Queen, lxvii.
- Apostles and Evangelists, Sarum Psalms, 339. 359. 377. 380. 397. 400. 453. 455. 476. 479. 483. 500. 511.
- Apostles, succession of Ministry from, 531; Bishops ordained by, 531; institution of the Order by our Lord, 530; power and authority of, 530; the three chosen ones pillars of the Church, 80; mystically signified by stars, 508; their office as rulers foretold, 407; their tribes, 407; care for the faith of their converts, 18.
- Apostolate, in substance an Episcopate, 530.
- Apostolic Christianity, how it reached Britain, xvii; "hours of prayer," constitutions quoted, 62; usages in H. Eucharist, 145; practice of Confirmation, 251.
- Apostolical Constitutions on Benediction of Water, 224; forbade single immersion, 211; on Gloria in Excelsis, 194; on Lord's Prayer after Baptism, 228.
- Apostolical Succession, Scriptural authority for, 531; Patristic authority for, 531.
- Appendix to Burial Office, 301; to Communion Office, 200; of four Prayers to Visitation of the Sick, 275. 287.
- Archbishop of Canterbury, *legatus natus*, 262.
- Archdeacon, duties of, in connexion with Ordination, 545. 554.
- Arian Form of Baptism, 211; heretics, their alteration of the Gloria Patri, 7.
- Arius, Heresy of, 42.
- Arles, Council of, on Lay Baptism, 212.
- Armenian Church, their time of observing Christmas, 83.
- Arnold's "Christian Life" quoted, 55.
- Article XXV., on Marriage, 273; on Sacraments, 249; XXVI. and XXXI. on Eucharistic Sacrifice, 188; XXVII. on Infant Baptism, 215; XXVIII., explanatory of "Black" Rubric, 199.
- Articles accessory to Divine Service not expressly mentioned, not forbidden, lxxi; of the Christian Faith, 245; "to stablish Christian quietness," 1536, 230, Orig., and n.
- Asaph and his brethren choristers, liii.
- Ascension Day noticeable, Ritual provision for it, 111; Sunday after, significant name of, 111; Psalms, 332. 341. 346. 380. 473.
- Ascension-tide, Sarum Psalms, 339. 341.
- Ash-Wednesday, Communion Service on, 307; Psalms, 322. 356. 367. 385. 457. 503. 516; its name ancient and popular, 91.
- Ashes, Benediction of, 92. 307.
- Assent and Consent of the Clergy, [7].
- Athanasian Creed, its reputed Authorship, 41.
- Athanasius, St., baptized some boys when himself a boy, 212; discouraged much musical inflexion in saying the Divine Offices, lviii; on Gloria in Excelsis, 194.
- Atheism, more subtle than open, 331.
- Athelstan's Psalter, Gloria in Excelsis in, 196.
- Augustine, St., and *Te Deum*, [53]; on burials, 295, 296; on catechizing, 241; on "children of God," 245; on Cross in Baptism, 209, n. 6; on Cross in Benediction of Water, 225, n. 1; effect on him of Church Music, lvii; regarding ceremonies, [21]; on Christianity in Britain, 453; on "the Lord is King," 453; on Infant Baptism, 215; on Lay Baptism, 212; on Manichæan rejection of Water, 210; on Marriage, 261; note from his Confessions, 10; on the early use of Psalm xxii., 342; on obligations of Sponsors, 248; prayed for his deceased mother, 301; Sermon on St. Stephen's Day, 78; on *Sursum Corda*, 133; visited the sick, 275.
- Augustine, St., of Canterbury, his Mission from St. Gregory, [47]; false impressions of, xvii; his difficulties with the British Church, xvii; Archbp. of Canterbury, [47]; revision of English Liturgy, 147. 149.
- Augustinian Canons, [53].
- Auricular Confession, 283; use of, 177.
- Authority, who in place of, [11].
- Average age of mankind, 445.
- Babylon, the Mystical, 381. 418. 510.
- Bacon, Lord, his saying respecting Nonconformists, xxxix.
- Baker, Sir Richard, on the Lord's Prayer, 6.
- Bancroft, Bishop, his collection of Canons, lxviii.
- Banns, the publication in Church of intended marriages, 171. 261.
- Banns, rubric on, incorrectly printed in modern Prayer Books, 262.
- BAPTISM, the initiatory Sacrament, wherein we are born again of water and of the Holy Ghost.
- Baptism, the actual administration, 226; of Adults, 236; ad-

- ministration of, in 6th century, 209; administration of, in Primitive Church, 209; allowed in private houses to royal children by a mediæval rubric, 215; ancient customs in, 217. 221; answers on, in Catechism, 244—246. 249, 250; by father of child, why not seemly, 216; clinic, 211; conditional, 235; earliest office for, 209; its effect, 213; essentials of, 210; evidence on, from Acts of Apostles, 209; "Form" in, 210; variation of, 211; history of, 208; how long after birth, 231; how typified in the beginning of Miracles, 85; of Infants, 208; Introduction to Offices for, 208; iteration of, 217; Jewish, 208; of St. John Baptist, 208; "Matter" in, 210; the Minister of, 212, 239; not to be delayed, 215. 231; of the world by the Deluge, 218; of our Lord, consecrated water, 84; of our Lord, anciently commemorated, 83; Private, 231; Public, Office for, 215; in Riper Years, 236; by sprinkling, 211; by surgeons, 212; by women, 212; time for, 217; uses of word in N. T., 208; Verbal and typical foreshadowings of, 208; Vows, 222.
- Βάπτισμα, Βαπτίζω, Βάπτω*, 208.
- Baptismal Office—its former Preface, 102.
- Barnabas, St., Festival, Epistle, and traditions respecting him, 136; on duration of world, 445.
- Bartholomew, St., identified by some with Nathanael, 139; traditions respecting him, 140.
- Barwick, Dean, first to restore the Choral service in 1660, xxxvii.
- Basil, St., on daily offices of the Primitive Church, 62; on Baptismal Renunciation, 222; his Epistle to Neocæsarea, 46; Liturgy of, 146; on Marriage, 261; on trine immersion, 211.
- Battle cry of "St. George for England," its probable origin, 45.
- Baxter, his obj. to prayer after marriage service, 272; Prayer Book of, xxxix. [12].
- "Beating the bounds," 48.
- Beauvais, Bapt. Office of, 220.
- Bede, The Venerable, 49; on the "Baptism of John," 208; on St. Cuthbert's Confirmations, 252; his Calendar, [36]; his Martyrology, [37]; his Shrine, [47].
- Bees swarming on lips of St. Ambrose, 45.
- "Before the people" in Commun. rubric explained, 186.
- Beheading of St. John Baptist, 53.
- Beleth, his authority for St. Jerome's Lectionary, 70.
- Belief, vow of, in Baptism, 222.
- Bell at Pittington, near Durham, its legend, 51.
- Bellarmino on the Episcopate as an Order *jure divino*, 566.
- Bells on Maundy Thursday, and Easter Eve, 103.
- Benedicite, its proper Doxology, 15; of Jewish origin, 13; when to be substituted for the *Te Deum*, 11. 15.
- Benedict, St., Life of, 6; his Rule, [43]; his Rule for the daily offices, [63]; his Rule, the earliest direct mention of the *Te Deum*, 10; his Rule on the *Gloria Patri*, 7.
- Benedict and Gregory, SS., their practice, on what based, [63].
- Benedictio Fontis, 224, 225, Orig.
- Benedictio Sacramentalis, after Marriage, 272.
- BENEDICTION, the priestly act whereby the blessing of God is conveyed to the faithful.
- Benediction in Confirmation, 260; in Communion Office, 195; of Elements, the nucleus of the Liturgy, 145; on Easter Even in Early English Church, 103; of Font, 209, 210. 584; of primitive antiquity in Liturgical use, 28; of the water, 224; of water, its spiritual import, 225; of water, separate from adm. of Baptism, 224; of water, in P. B. of 1549, 225; of water quite distinct from that of Eucharistic Elements, 226; of Palms, 96; final, after Marriage, 273; in Vis. of Sick, 286; Levitical, in Vis. of Sick, 287; Apostolic, in Bur. Office, 300.
- Benedictus, the proper Cantic after 2nd Lesson, 16; its position and Ritual meaning, 18; in Communion Office, 184.
- Bernard, St., his saying on the death of the Innocents, 81; on the Candlemas Festival, 131.
- Bethell, Bp., on Baptismal Regeneration, 230.
- Bethphania, a name for the Epiphany, 83.
- Betrothal, 236.
- Beverley, St. Mary's, register on prohibited seasons for Marriage, 263.
- Bezaleel, his inspired wisdom given for ceremonial worship, xlvi.
- Bible, delivery of, to Bishops, 538. 575; delivery of, to Priests, 538. 564; imposition of, on Bishop elect's neck, 575; the Great, title of, xxvii.
- Bidding of Holydays, 171.
- BIDDING PRAYER, a proclamation of persons commended to the prayers of the faithful, made by preachers before sermons (Can. 55).
- Bidding Prayer, 172; in Ireland, 586.
- Bidding Prayers; petition for giver of holy bread, 198.
- Bill, King's printer, royal mandate to him A.D. 1661, xxxvii.
- BISHOP, a Church officer of the highest order, having spiritual capacity to ordain and confirm in addition to the spiritual capacities belonging to the priesthood.
- Bishop and Priest, Names of, not at first distinguished, 531.
- Bishop or Priest, the proper Minister of Adult Baptism, 239.
- Bishops, a distinct Order from Priests, 566; superiority of, "*jure divino*" asserted by Bancroft, 566; inherit the ordinary parts of the Apostolic office, 530; ordained by the Apostles, 531; Order of, essential, 531; no Church without, 543; succession of, 542; Fathers in God, 546; Election of, 568; to be consecrated by their Metropolitan, 567; three, required at a consecration of one, 567; consecrated in their own Cathedral, 567; Consecration of, held on Sundays or Holydays, 567; elect, habit of, at Consecration, 568; vestments of, as represented on Brasses, 574; vestments of, by 2nd Prayer Book of Edward VI., 574; Summary of ancient Offices for Consecration of, 534, 535; Delivery of Bible to, 538; five consecrated according to the Ordinal of 1549, 536; one consecrated according to the Ordinal of 1552, 536; of the same Province to assist at Consecrations, 567; deposed if only consecrated by two others, 567; Senior, consecrator in absence of the Archbishop, 567; Service for Consecration of, 1662, 537; special powers of, 543; only to ordain in their own diocese, 541; sanction required for Adult Baptism, 238.
- "Black Rubric," 199.
- Blasius, St., B. and M., [41].
- Blessing in Communion Office, 195; in Marr. Service, 270.
- Blood-thirsty, application of term, 395.
- Blow on cheek in Confirmation, 252. 259.
- Boanerges, meaning of, 80.
- Bodleian Library Psalters, 314; MS., 292.
- Body of the Church, why permitted for Celebration of H. C., 165; the place for Marriage, 263.
- "Body prepared," LXX and Vulg., 370.
- Bona, on Collects, 68; on Gloria in Excelsis, 194.
- Boniface, St., 49; on Conditional Baptism, 235.
- "Bonour" and "buxum," meaning of, 267, n. 6.
- Book of Common Prayer, 1661, Preface of—its moderation—written by Sanderson, Bp. of Lincoln, 11; its chief Illustrators, and Commentators, v; National Versions of it, xlv; materials used in its composition, xxvii.
- Book of the Gospels, reverence anciently shown to it, xlix.
- Books of Hours, xxiv.
- Books of Reference to Lessons, Gospels, and Epistles, xxiv.
- Borromeo, Carlo, a Musical Commissioner, by appointment of the Council of Trent, lix.
- Bouchier, his Commentary and early Calendar, 36.
- Boughen, Edw., on Sign of Cross in Confirmation, 258.
- Boughton Monchelsea, Espousals in register, 267.
- Bowing at the Holy Name elsewhere than in the Creed, 20.
- "Boy-Bishop," [61].
- Boys, Dean, on the Prayer Book, v.
- Bracara or Braga, Council of, on burial of suicides, 294.
- "Bread," and "mingled wine," of Wisdom's Table, 152; breaking of, in Consecration, 187; fermented or leavened in Eastern Church, 198; for Sacramental use, 198.
- Breastplate of Aaron, 407.
- Breviary, Daily Services of, xxviii; its complex character, [63]; Hymns, unsuccessful attempts to translate them, lxii; Roman, Reformation of, xx; services, never familiar to the laity, xx.
- Bride and Bridegroom in 45th Psalm, 378.
- Bride, The voice of the, 330.

- BRIEFS**, declarations and recommendations read after the Nicene Creed to commend special objects for the Offertory.
- Briefs**, 171.
- Bright, Mr.**, on the Ancient Collects, 118.
- British Bishops**, their independence, xvii. 47; Church, founded in Apostolic age, 532; represented at Councils, 532; mentioned by Fathers, 532; its Rites, its Bishops, xvii; Museum Psalters, 314.
- Britius or Brice, St.**, [59].
- Broadwater**, Marriage custom at, 263.
- Brook, Lord**, Anecdote of, 51.
- Brougham, Lord**, on Lay Baptism, 213, n. 2.
- Bryling, Nicholas**, Greek text of Ath. Creed, 45.
- Bucer**, his desire for frequent Communion, 308; on frequent Communion, 177; his interference with Benediction of water, 225; his objection to answers of Sponsors, 224; his objection to the exorcism in Baptism, 219; his objection to prayers for the dead, 295; placed at Oxford by Somerset, xxx.
- Bull, Bishop**, recites Bapt. Off. from memory, xxxvi; on Nicene Creed, 171, n. 1.
- Bunsen**, on Liturgy of St. Mark, 146.
- Burial of the Dead**, 293; Office, in what cases to be used, 293; Ps. xlii. formerly used, 295. 372; Office, Psalms, 369. 445; Office with Evensong at St. Paul's, 296.
- Burial with Christ in Baptism**, 211.
- Burleigh, Lord**, his challenge to Dissenters, xxxix.
- Burney, Dr.**, on Modern Jewish Music, lvi.
- Burn's Ecc. Law on Baptism** by Midwives, 212.
- Burton**, author of Anat. of Melancholy, used Wafer Bread, 198.
- "Buxum,"** meaning of, 267, n. 6.
- Cæsarea**, Creed of, 170.
- Cæsarius of Arles**, on Sursum Corda, 183; his Rogations, 46; Sermons on Advent, 72.
- CALENDAR**, the list of months and days, together with the Sunday letters and Holydays.
- Calendar**, Additions in 1661, [37]; alterations in 1752, [27]; changes in 1561, xxxv; of Church of England, Changes and Reformation, [36], [37]; of the Church of England, always local in character, [36]; Ecclesiastical, what it comprises, [36]; English, necessary changes in, 36; English, its transitions, [36]; the existing English, with whom it originated, [39]; Introduction to, [36]; of Lessons, 1549, xxviii. [25]; table of its Transition, [36].
- "Calendarium Floriacense,"** 36.
- Calendars**, Byzantine, [37]; of the Church of England, published by Stationers' Company, [36]; their early use and origin, [36].
- Calvin's interference in the English Reformation**, xxx, xxxi.
- Candlemas Day**, why so called, 131.
- CANON**.—1. The Prayer of Consecration. 2. An ecclesiastical law so called. 3. The official designation of certain dignitaries in Cathedral and Collegiate Churches.
- Canon 71**, on private celebration, 290; 81, enjoins large stone font, 217; 18, on reverent gesture, 20; 20, requires flagon, 199; 29, altered in 1865, 216; its strictness partly accounted for, 217, n. 1; 30, on the Cross in Baptism, 227; 55, on Bidding Prayer, 172; 59, on Catechizing, 243; 60 and 61, on Confirmation, 253; 62, on Banns or Licence, 261, 262; 64, on bidding of Holydays, 171; 67, on Visitation of the Sick, 275; 68, on delaying Baptism, 216; on refusing to Bury, 293; 69, on deferring Baptism, 232; 112, on age for Communicants, 253; 113, on Seal of Confession, 283; Latin, of 1571 on Catechizing, 243; Law of Burial, 293, 294.
- Canon Missæ**, 145. 186. 201. 203. 205.
- Canonical limitations as to hours and seasons for Marriage**, 263.
- Canonization by the Popes**, [36].
- Canons**, early Eng., on Comm. of Sick, 239; how far binding on the Clergy and Laity, lxxviii; of 1640, their design, lxxviii.
- Cantate Domino**, why inserted in Daily Service, 34.
- CANTICLE**, a prose hymn used in Mattins and Evensong. All the Canticles are from Holy Scripture, except "Te Deum laudamus."
- Canticles**, The, Ancient Ritualistic use of Holy Scripture, 9; their leading principle, 10.
- "Canticum de Evangelio,"** spoken of by St. Benedict, 16.
- "Cantus Ambrosianus,"** extended use of the term, lvii; Antiphonalis, 315; Collectarum, lviii. lx; Directus, 315; Prophetarum, lviii. lx; Responsarius, 315.
- Capella**, Origin of the term, [59].
- Cappadocia**, Martyrdom of St. Matthias, 133.
- Caps of children to be removed in Baptism**, 226; to be worn by women to be Baptized, 240.
- Captivity of Church and Incarnation**, 436.
- Cardwell, Dr.**, his suggestions as to the Revision of 1552, xxxi.
- Carter on Eucharistic words**, 153.
- Carthage**, 4th Council of, on Marriage, 261.
- Cassino, Mount**, Cradle of Benedictine Order, [43].
- CASSOCK**, the garment worn by ecclesiastics under their official vestments and at other times. The "apron" worn by Bishops, &c., is a cassock curtailed.
- Catalonian Pontifical on Confirmation Address**, 256.
- Catechetical Lectures of St. Cyril of Jerus. and of St. Clem. Alex.**, 241; works of English Divines, 243.
- CATECHISM**, an oral instruction to be learned by young persons, that they may be the better prepared to receive Confirmation.
- Catechism**, basis of, 243; comprehensive but not exhaustive, 243; definition of in P. B., 244; on effect of Baptism, 213; Introduction to, 241; latter part of its history, 242; of 1549, Commandments in, 246; in P. B., origin of, 241; in Hermann's Consultatio, 242, n. 1; of Council of Trent, 242; in Latin and English of Poynt, 242.
- Catechisms**, Protestant, 242.
- "Catechismus,"** derivation of, 241.
- Catechizing in Church** not superseded by school work, 243; of our Lord, 241.
- Catechumens**, admission of, 209, n. 4, 210; instruction of, 241.
- Cathari, or Puritans**, their "baptism with fire," 210.
- "Cathedra Petri,"** an ancient Festival of SS. Peter and Paul, 131.
- Cathedral and Collegiate Churches** to provide copies of Book of Common Prayer, [10].
- Cathedrals, &c.**, to observe rule of weekly celebration at least, 198.
- Catholic Church of Christ**, position of English Church in, [13].
- Cantela Missæ**, 197.
- Caution to be observed in Vis. of Sick**, 283, n. 1.
- Cecil licensed Poynt's Catechisms**, 242.
- Cecilia, St.**, [61].
- Cedde, St., v. Chad**.
- Celebrant**, his office, his dress, his position at the Altar, 159; his posture in receiving, 189.
- Censing of the Altar**, 149. 200.
- Cephas**, 138.
- Ceremonial before Mosaic Ritual**, xlvi; Worship, xlvi; its principles, xlvi. l, li; recognized and observed by our Lord, xlviii; as set forth by St. John, xlix, l.
- Ceremonies of the Ch. of England**, explanatory Canon on, xxi; empty, condemned, xlviii; in some cases could not be reformed, [22]; their abuse illustrated, [21]; Christian, ordained by our Lord, xlviii; justification of, [20]. [22]; of human institution may be changed, [21], [22]; rights of National Churches to be respected [22]; St. Augustine on their excessive number, [21]; why some were rejected, [21].
- Certification of Private Baptism**, form of, 232.
- Chad, St.**, [43]; his custom in a thunder-storm, 50.
- CHALICE**, the cup that is used in the celebration of the Holy Eucharist.
- Chambers' translation of the Sarum Psalter**, 21; Sarum Psalter, ending of Collects, 70.
- CHANCEL**, the eastern division of a church, where the Altar and Choir are placed, and in which Divine Service is celebrated.
- Chancels**, their desecration in the last century, 64.

- Changes in Prayer Book after Hampton Court Conference, xxxiv ; Liturgical in 1549, their nature and principles, xxviii.
- Chant of the old Litany retained and harmonized, lx.
- CHAPEL, a building licensed for Church Services other than a Cathedral, Collegiate, or Parish Church.
- Charles I. and Liturgy for Scotland, 581; Martyrdom, Service abolished, [39]. 578.
- Charta, Cornutiana, 70.
- CHASUBLE, the outermost and distinctive vestment of the priest who celebrates the Holy Eucharist: it is never worn at any other service. [See Ecc. Vestments, Plate I.]
- "Child of God," a Scriptural term, 244.
- CHIMERE, the garment worn by a Bishop over his rochet, now usually of black satin, but properly of scarlet.
- Chimere, notices of, 574.
- CHOIR.—1. The *chorus* or body of men and boys who sing in the Divine offices. 2. That part of a cathedral, church, or chapel, in which they sing (chancel).
- "Choir," its early use for our present word "answer," 8; of the Temple, Levites, 313; Surpliced, their origin, 313.
- Choral Processions in the Jewish Church, li.
- Choristers of the Temple, liii.
- Chosen Disciples, The Three, their work and influence, 80.
- CHRISM, holy oil used in anointing at Coronations, or in the unction of the Sick, provided for in the 1st Book of Edward VI.
- Chrism, used in Baptism, &c., 209, 210, 222, 227, Orig.; used in Confirmation, 251, 252, 258; when it was Consecrated, 99.
- CHRISOM, the white robe formerly put on children when they were baptized.
- Chrisom, 209, 210, 222; formerly offered at Churchings, 306; in P. B. of 1549, 227.
- Christ, the True Bread from Heaven, 151; the Light, 485; the Representative Penitent, 322, 356, 385, 457, 516; and the Bride, 379, 502; bringing His sheaves home, 501; and the two-edged sword, 524; Creator of natural and spiritual world, 521.
- Christ's two Natures prophetically shown, 336, 351; glory that of His Church, 379, 480; Evening Sacrifice, 514; victory by Incarnation, 517.
- Christian Name used in offices of Church, 244; Service, the first, liv; Year, no way connected with January 1st, 83; the, beginning on Lady Day, 73.
- Christmas Day, how early the Festival was observed, 76; Sermons of Gregory Nazianzen and Basil, 77.
- Christmas Eve, coincidence in the Lesson and Psalm, 76, 379.
- Christmas and Epiphany Festivals, their association, 77; how it was anciently observed, 77; Psalms, 339, 377, 436, 441, 476, 504; Sarum Psalms, 377, 380, 414, 436, 441, 452, 454, 476—479, 484, 503, 504, 518, 520, 521.
- Chrysostom, St., on Baptism, 209; Christmas Homily, 76; eulogium of the Benedicite, 14; efforts to counteract Arian Hymns, lvii; Prayer of, first use in Western Ritual, 28; on Fasting, 90.
- Church, The, how it is made an Ark of safety, 87; of Jews and Christians continuous, 465; the true *anima mundi*, 459; its history in 106th Psalm, 467; its early refuges from persecution, 329; early British, 532; of England, Title found in Magna Charta, [2]; Music, its Divine authority, lii; no "Non-essential," lii; Song, its vicissitudes, lix; officers, representative, li.
- Churches of France and England, their early connexion, [39]. 147.
- Churches, their earliest form and arrangement, xlix.
- Churching of Women, 304; time for, 306; place for, 305; cloth, formerly at St. Bene't's Gracechurch, 304; Psalms, 482, 501.
- CHURCHWARDENS, lay officers appointed to take charge of the fabric and furniture of churches, to keep order during service, to present at visitations, &c.
- CIBORIUM, a vessel for the reception of the consecrated wafers, 173, n. 2.
- Citations, 171.
- Circumcision, Festival of, 82; its true idea, 83; Sarum Psalms, 339, 346, 377, 380, 439, 452—454.
- Clarendon, Lord, Anecdote of, xlii, n.
- Clee Church, dedication inscription, [59].
- Clement, St., of Alexandria, mentions Feast of Nativity, 77; catechized, 241; on Gloria Patri, 7.
- Clement, St., of Rome, [61].
- Clementine Liturgy, Position of Sanctus and Hosanna in, 183.
- Clergy and Lay people, distinction asserted, 540; nature of distinction, 540.
- Clergy and People, Prayer for, Cosin's proposed alterations in, 28.
- Clerk to accompany Priest in Vis. of Sick, 276, 277, marg.
- CLERKS.—1. Ordained clerics. 2. Laymen assisting in Choir.
- Clerks, commonly reduced to one, [64]; to sing at burial of dead, 296.
- Clinic Baptism, 211.
- Cloveshoe, Council of, xviii.
- Cloviss, Conversion of, [57].
- Coffins, baskets, or pots, in Ps. lxxxi., 433.
- Coke, Lord, on Confirming by name, 258, n. 2; on Pope Pius IV. and Prayer Book, xxxv.
- Colet, Dean, his intimacy with Erasmus, 242.
- COLLECT, a short prayer (methodically constructed) either proper to a day, week, or season, or common to all times.
- Collect of the day, 69, 168; its office, rules for its use, 24; 2nd Even Song, ancient English Version, 38; 3rd Even Song, Cosin's proposed alteration, 40; Third, Old Rubric, 25; for Purity, 166; for Sovereign, 167; for early Christmas-day Communion, 77; for St. Stephen's Day, its enlargement in 1661, 79; for Epiphany, 6th Sunday Original by Bp. Cosin, its peculiar suitability, 88; for Easter procession, 105; after Baptism, its doctrinal import, 228; in Confirmation Office, 259; in Vis. of Sick, 285; in Burial Office, 300; Epistle and Gospel in Comm. of Sick, 289; for St. Mary Magdalen's Day, [51].
- Collects, Origin of Name, 69; structure and characteristics, 69, 70; comparison of two composed at an interval of 1000 years, 69; come to us chiefly from the 5th and 6th centuries, 68; their primary use—from ancient Sacramentaries, 70; New, in 1552, 1661, 70; Occasional, at end of Communion Office, 195; for Easter and Low Sunday changed in 1661, 107.
- Colloquial Tone in Divine Service, lix.
- "Collusion" in connexion with Private Baptism, 232.
- Colours, Ecclesiastical, English, lxxviii; comparative table of, lxxix.
- Comber, Dean, on use of Jubilate, 17
- "Comes" of St. Jerome, 70.
- Comfortable Words, 182.
- Commandments, their Eucharistic use and its probable origin, 166; in the "Great Bible" translation, 247.
- Commemoration of Founders and Benefactors, Psalms for, 518, 520.
- "Commemorations," [16]; of Departed, 302; of Departed in Primitive and in English Liturgies, 156, 176; of Martyrs, [36]; of B. V. Mary, 134.
- "Commendatio Animarum," 287.
- "Commendatio Benefactorum," Elizabethan form of, 303.
- Commendation of Souls, Sarum Psalms, 486, 511.
- Commendatory words in Burial Office, 298.
- Commentators on the Prayer Book, v.
- COMMINATION, "A denouncing of God's anger and judgments against sinners," used on Ash-Wednesday, and "at other times as the Ordinary shall appoint."
- Commination, 307; when to be used, 307; formerly used on Sundays, 308; Psalm, 385.
- Commission to revise Calendar, xxxv.
- Committee of Convocation for Office of Adult Baptism, 237; for revision of 1661, xl; for Reform of Service Books, their cautious progress, xx, xxi.
- Committee of Revision, 1559, xxxiv; how their completed work was finally authorized, xxix.

- Common Order, Knox's Book of, xlv.
 "Common Prayer," a very ancient term, [2].
 Commons, House of, desire to enforce reverence, xlii; care to preserve Prayer Book and Act of Uniformity intact, xliii.
 COMMUNION, the receiving of the Body and Blood of Christ by the faithful in the "Lord's Supper," and the consequent union of them with Christ, and Christ with them.
 Communion with God by bodily acts chiefly, xlvi.
 Communion, variable parts of Service, very ancient, 68; on Good Friday, 101; "Table," an objectionable term, not found in P. B., 164; Psalm xxxiv. in Lit. of St. James, 359; spiritual, 291; after Marriage, 262, 263, 273, 274; of the Sick, 289; of Clergy and People, 151, 189. [See Holy Communion.]
 Compatriini et Commatrinæ (sponsors), 222, Orig., 224.
 "Compiled," a term inapplicable to our Prayer Book, vi.
 Compline and the departed, 506.
 Conception of B. V. Mary, [61].
 "Concerning the Service of the Church," [15].
 Concessions offered by the Bishops at Savoy Conference, xxxix.
 Condensation of Old Services, xxviii.
 Conditional Baptism, 235.
 Conditions proposed by St. Augustine to British Bishops, xviii.
 Confederacies against Christ, 435.
 "Confess," word formerly used where now "Confirm," 241, 255.
 Confession and Absolution in Communion Office, 149, 181, 200.
 Confession, Auricular, or private, 283; national, in 106th Psalm, 466; law of Ch. of Eng. on, 283; private, remedial, 177; of Sick, various directions for, 283; in Visit. of Sick, 283.
 CONFIRMATION, the laying on of hands by a Bishop, for the purpose of strengthening persons in the grace of Baptism by a further outpouring of the Holy Spirit.
 "Confirm," confusion in use of term, 241, 255.
 Confirmation, a Sacrament, 252; connected with Catechizing, 241; act of, 258; custom of modern Eng. Bishops in, 252, and n. 1; in mediæval English Church, 251—260; in Eastern Church, 252, 257, n. 1; "a lesser Ordination," 253; essential to perfection of Christian life, 251; effect of, 253; followed by Baptism immediately, 251; to follow Adult Baptism, 238; of Infants, 251; separated from Baptism in later days, 252; necessary before Holy Communion, 251, 260; frequency of, 253, and n. 2; Office, 254; Introduction to, 251; in P. B. of 1549, 254, &c.; act of, 258; Office, mediæval, 256, Orig. &c.; Address of Bp. Cosin, 256; age for, 253, and n. 3; blow on cheek in, 252, 259; change of name in, 258, n. 2; Chrism in, 251, 252, 258; the complement of Baptism, 253; sign of Cross in, 252, 258.
 Congregation, meaning of, 564; synonymous with Church, 564.
 CONSECRATION.—1. The priestly act whereby the Eucharistic elements become the Body and Blood of Christ. 2. The Episcopal act whereby other Bishops are made. 3. The solemn Benediction and de-secularization of churches, &c.
 Consecration of Bishops, anciently at the third hour, 567; always preceded the Gospel, 567; before the Epistle in the Greek Church, 567; of churches, service in Irish Prayer Book, 586; Service, the first, liii; Services, modern, liii; Prayer of, 186; of Elements, effected by words of Institution, 187; great exactness and reverence necessary in, 187, 188; in Holy Eucharist, its effect, 155.
 Consent, Mutual, 265.
 Constantinople, its Arian Hymnology, lvii; Council and Creed of, 170.
 Constitutions, Archbp. Grey's, Archbp. Peckham's, Archbp. Winchelsy's, lxxiv.
 Consuetudinary of Sarum, on Festival of Annunciation, 133.
 Contact of water necessary in Baptism, 212—226.
 "Contestatio," Gallican term for Proper Preface, 185.
 Contracts *de futuro* and *per verba de presenti*, 267.
 "Convenient," meaning of term, 274, 306; number to communicate required by ancient Councils, 197; place for Churching, 305.
 Convocation, Office for meeting of, 580; Prayer for, included in that for Parliament, 61.
 Conybeare and Howson referred to, Life and Labours of St. Paul, 181.
 COPE, a vestment like a long cape or cloak, worn in solemn services, processions, &c. [See Ecc. Vestments, Plate II.]
 Cope worn by Bishop Cosin, 574; substituted for Chasuble, 159.
 Copes, when worn by Bishops, 574; worn in Convocation, 1562 and 1640, 574.
 Coptic Liturgy of St. Mark, 146.
 Cornelius and his household baptized, 211.
 Cornelius à Lapide, calculation regarding the miracle of the loaves, 95.
 Cornu Altaris, 160.
 Coronation Office, Prayer of Oblation in, 174.
 Coroner's warrant for burial, 294.
 CORPORAL, the white linen cloth on which the Elements are consecrated; it lies upon and in the centre of that which covers the Altar.
 Corporal, 191.
 Correctors of the Press for Prayer Book of 1662, xlii.
 Cosin, Bishop, his Liturgical learning, Preface vi; his Durham Prayer Book, xli; his careful directions to the Printer, xlii; his statement on Rubrics, xxi; his prophetic desire to place the Rubric beyond controversy, lxxv; his note to the first Rubric, lxvi; Collects which he composed or compiled, 70; Additional Proper Psalms proposed by him, [26]; "Tables and Rules" from his Private Devotions, [27]; additions to Calendar from his Private Devotions, [37]; his wish to revive the use of invitatories, 7; his Rubric on Antiphonal use of Psalms, 8; his Rubric on singing the Lessons, 9; on "Jube," 307; his Ember Collect, 63; his Thanksgiving for restoration of peace, 67; his alteration of Collect for St. Stephen, 79; his Collect for Third Sunday in Advent, 74; his Collect for Sixth Sunday after Epiphany, 87; his Collect for Easter Even, 102; his Collect for Rogation days, 110; his Rubric as to position and furniture of Holy Table, 165; his Rubric on Epistles and Gospels, 168; his proposed Rubric with regard to Alms, 199; his classification of Offertory sentences, 174; his propositions with regard to Church Militant Prayer, 175; on Exhortations in Communion Office, 177, 180; his alteration of Prayer of Humble Access, 186; his alteration of Rubric on Confession in Communion Service, 182; his proposed restoration of ancient mode of Consecration, 186; alterations after Prayer of Consecration, 189; on position of Prayer of Oblation, 192; on Eucharist for Departed, 192, 296; his emendation of Rubric on Occasional Collects, 195; his alterations of Final Rubrics of Communion Office, 197; on Solitary Masses, 198; his emendation of Rubric in Baptismal Office, 217; his direction for kneeling at Font, 218; his directions for Gospel at Baptism, 220; his wish to restore old custom in Baptismal Confession of Faith, 223; on Benediction of Water, 225; his alterations in Form of Baptismal Renunciation, 222; his alterations in Baptismal Interrogations, 224; first introduced Vow of Obedience in Baptismal Office, 223; his alterations in Exhortation to Sponsors after Baptism, 229; his addition to Rubric on Minister of Baptism, 213; on certification of Private Baptism, 232; his transference of Lord's Prayer in Private Baptism, 233; his alteration at end of Office for Private Baptism, 234; on Office for Adult Baptism, 236; on latter part of Catechism, 242; on Sacrament of Confirmation, 252; on Confirmation Office, 254, 255; M.S. Confirmation Address of, 256; on lax practice in Confirmation, 253; on Impediments of Marriage, 262; on times for Marriage, [28], 262; on procession in Marriage Service, 271; his alterations in Marriage Exhortation, 264; his proposal regarding delivery of money in Marriage, 268, 269; on Comm. after Marriage, 274; on Confession of Sick, 283; his provision for responses in Visitation of the Sick, 276; his Rubric after Vis. Office, 288; on Puritan objection to Christian burial, 296; on burial in Divine Service, 296; suggested first Rubric of Burial Office, 293; on custom of Priest casting earth, 298; his introduction of Benediction in Bur. Office, 301; on time for Churching, 306; his Rubric for Churching of Women, 304; his

- alterations in Communion Service, 307; revised Service for Nov. 5, 578; his four sets of notes on the Book of Common Prayer, xli.
- Council of Laodicea ordered alternate use of Psalms and Lessons, 9.
- Council of Maçon enforced observance of Advent, 73; forbade Baptism save at Easter, 216.
- Conc. Nannetens. on Visit. of Sick, 280.
- Councils enjoined Visit. of Sick, 275.
- Covers for Chalices, 188, n. 1.
- Covering Consecrated Elements, 191.
- Coverings and hangings anciently used for Altars and Chancels, lxxviii.
- Cramp rings, their use and origin, [57]; Service for consecrating them, 580.
- Cranmer, *Abp.*, his answer to Devonshire rebels, 216, n. 1; asserted antiquity of the Prayer Book, xxx; his efforts for Ritual revision, xx; his letter to the King, xxi; on Rites and Ceremonies, [2].
- Creation, its true story truly told by the Creator, 461.
- CREED, a form of words in which the Church solemnly asserts the Catholic Faith. The three Creeds are also used as Christian Hymns or Canticles.
- Creed, Apostles', traced back to the time of the Apostles, 18; as stated by Irenæus, 18; its form in the latter part of the fourth century, 17; used in its present form in the eighth century, 17; ancient tradition of the early Church, 18; numerous versions of it in early English, 36, 37; ancient Trilingual version, 36; always used in the daily Offices of the Church of England, 17; its position in the Service, 19; an expository paraphrase of it, 20.
- Creed, Athanasian, supposed origin, 41; Confession of Orthodoxy against heresy, 42; in ancient usage always sung, 41; expository notes on, 42.
- Creed, Nicene, 169.
- Creed in Bapt. Office, 228; in Baptism, how divided in first Eng. Office, 223.
- CREDENCE, the side-table on which the Elements are placed previous to the lesser Oblation or Offertory.
- Credence Table, 159; sanctioned by the Queen in Council, lxxi.
- Creeping to the Cross, what it was, 100.
- Crisis of Old and New Dispensation, 480.
- Crispin, *St.*, [57].
- "Cristene," for "Baptize," in baptismal Form, 231, Orig.
- Critics, Modern, on the Psalter, 313.
- CROSS.—1. The sacred sign used in Holy Baptism, &c. 2. The Ornament placed over the centre of the Altar, and used generally as a badge of Christianity.
- Cross of St. Andrew, [45]; a part of our national banner, 129; sign of the Son of Man, 439; sign of Christ Triumphant, 436; in Baptism, 209, n. 6, 210; its lawful use in Baptism explained, 227, n. 1; over the Altar, 159; the reverence to it always popular, 100; sign of, in Benediction of Water, 225, and n. 1; sign of, in Confirmation, 252, 253; sign of, in Marriage Benedictions, 270, 273, 273; buns, their probable origin, 151, n. 4; quarter days, [53]. [59].
- CROZIER, the Cross borne by or before Archbishops only. The term is often, but incorrectly, applied to the crook or pastoral staff proper to the Episcopal Order generally.
- CURATE.—1. Any person having the cure of souls committed to him by the Bishop. 2. One acting for a beneficed cleric. [See Canons of 1604.]
- "Curate," old use of term, 23. 254. 551; comprehensive sense of word, 232, n. 1.
- Chrysostom, *St.*, Liturgy of, 146. 173; Prayer of, 196; on Eucharistic Commemorations, 156; on Amen after Prayer of Consecration, 189; on Sursum Corda, 183; on Gloria in Excelsis, 194.
- Curtains at ends of Altar, 165.
- Custom, gives some sanction to neglect of rule, lxxix.
- Cuthbert, *St.*, Confirmations by, 252.
- Cyprian, *St.*, on the Apostolic Hours of Prayer, [62]; on Common Prayer, 2; on Martyrdom of the Innocents, 81; on Sursum Corda, 183; on Baptism, 209; on the Minister of Baptism, 212; on Infant Baptism, 215; on Interrogatory in Baptism, 222; on Benediction of Water, 224; on heretical baptism, [55]; on Confirmation, 251; on Creed in Baptism, 223; on clinic baptism, 211; on burial, 295, n. 2.
- Cyril, *St.*, his exposition of the Lord's Prayer, 31; on Lord's Prayer at Greater Oblation, 191; on mode of receiving Elements, 190, 191; on Confirmation, 251.
- Cyril, *St.*, of Jerusalem on Eucharistic Commemorations, 156; on Sursum Corda and Tercius, 183; on Baptism, 209; on Bapt. Renunciation, 222; on Benediction of Water, 224; on Creed in Baptism, 223; on effect of Baptism, 213; Catechetical Lectures of, 91. 241.
- Daily Celebration, 161; no Canon respecting, in English Church, 162; provided for in P. B. of 1549, 162.
- Daily Morning Prayer, Cosin on its proper beginning, 5; Offices, whence derived, 62; Prayer enjoined, 20; where to be said, 64; Service Books, early endeavours to render them intelligible, xix; Service, duty of Laity, [20]. [63]; principle of clerical use of, [19]; coincidences of the Scriptures in, &c., 416.
- DALMATIC, the outer vestment of the Gospeller at the Holy Eucharist. [See Ecc. Vestments, Plate I.]
- Damasus, Pope, and the Benedicite, 15; and the Lectionary, 70.
- Daniel on Gloria in Excelsis, 194, 195.
- David, a declared Prophet, 333; his office as chief Psalmist, 313; type of Captain of our Salvation, 517.
- David, *St.*, [43].
- Davies's Rites of Durham on the Jube, 307.
- Day, John, his great choral work, lxiii.
- Daye's Hermann, 215. 217. 218. 220. 221. 256. 259, Orig.; on joining hands in marriage, 270.
- DEACON, a Church officer of the third order, whose duty it is to assist the priest in divine service and pastoral work.
- Deacon, his duties at the altar, 160; not to say Absolution, 4; not to celebrate marriage, 264.
- Deacons, Baptism by, 550; Delivery of New Testament to, 538. 552; Reading of Gospel by, 552; form and manner of making, 545; Habit of candidates, 546; Prayers common to various offices for making, 532; Revision of Service for making, 1662, 537; Summary of office for making, 532, 533; to continue in their office one year, 541.
- Deadly sins, the seven, 245.
- Death unto sin in Baptism, 213.
- Decalogue, probable origin of its Eucharistic use, 166.
- DECANI and CANTORIS, the two sides of a choir, on one of which is the stall of the Dean or other principal officer, and on the other that of the Precentor.
- "Declare," "Declaratory," meaning of, 5.
- Declaration on kneeling, 199.
- Dedication of Church, Sarum Psalms, 379, 380. 435. 439. 446. 452. 455.
- Delegates of press at Oxford, their alteration of rubric, 262.
- Delivery of Elements to each person separately, 190; various forms in, 189; into hands, 190.
- Deluge, its typical import, 218.
- Demoniacal possession, deep sense of it in the Early Church, 94.
- Demons cast out, a continuation of our Lord's personal victory over Satan, 94.
- Denial of Cup to Laity, 150.
- Denton on the Lord's Prayer, referred to, 248.
- Denys, *St.*, or Dionysius, [57]; Areopagite, of France, [39]. [57].
- "Depart," old Eng. word for part asunder, 267.
- Departed, commemorated in H. Eucharist, 156. 174. 175. 192; Sarum Psalms for the, 399. 482. 486. 496. 497. 503. 510. 511. 518. 520. 522—524.
- Depraving of Common Prayer forbidden, [4]. [5].
- Deprivation of Ministers, 233, n. 2.
- Descent into Hell, 20. 102. 440. 473.
- Desecrated Churches, Service for in Irish Prayer Book, 586.
- Development of Liturgy, a gradual process, 145.
- Devonshire Rebels, their demands, and Cranmer's reply, xx.

- Dickinson, his list of printed Service Books, xix.
- Diocletian persecution in Ps. lxxxiii., 434.
- "Dionysius the Areopagite," on Oblation of Elements, 172.
- Dipping of the Child in Baptism, 226.
- Diptychs, Names of Martyrs inscribed on, 36; their Eucharistic use, 149. 156.
- Directorium Pastorale on Abstinence, 91; on Baptism by surgeons, 212, n. 1; rules for avoiding infection, 292.
- Directory, Presbyterian form of Communion, 207.
- "Disciplina arcani" with regard to H. Eucharist, 146, n. 2.
- Discipline, disuse of, 162; the difficulty of enforcing it, lxxvii.
- Discretion, years of, 238.
- Dissenters, Burial of, 293; Prayer Book, xxxix.
- Distribution of Elements in Comm. of Sick, 290.
- "Divine Service," meaning of term, lxx. [15]. 296; Worship, its central point, 24.
- Doctors, Four great, [43]. [45]. [53]. [55].
- Doctrine of Holy Communion, 151.
- Documents relating to Act of Uniformity, lxxiv, lxxv.
- Dogs, Non-Christian Jews so called, 395, 396.
- Dominica Expectationis, 111.
- "Dominicæ Vagantes," 128.
- Dominical or Sunday letter, [29]. [34]. [35].
- Donne, Dr., Marriage sermon, 274.
- Door of the church ancient place for Churching of Women, 304.
- Doubtful Baptism, 240.
- Doubts, Ritual, how to solve them, lxx. [18].
- Doxology at end of Exhortation in Comm. Office, 180; of Lord's Prayer, 6; of 107th Psalm, 472; proper to Benedicite, 15; the Great, 194.
- "Duly," equivalent to Latin "*Rite*," 193.
- Dunstan, St., [47].
- Duppa, Bishop, his Prayer Book, 51; on Churching of Women, 305; private prayers, 578; opinion of Scottish Liturgy, 582.
- Durandus, a laborious and painstaking writer, 72; on connexion between Christ and His Martyrs, 78; on Canonical seasons for Marriage, 263; on Missa Sicca, 197; on the time of observing Lent, 89; on the use of the Venite, 8; on three Epiphanies, 83.
- Durel's Latin Prayer Book, 586.
- Durham Cathedral, Copes worn at, 159.
- Duty to God and our neighbour on tablets at Ely, 242; towards God, 247; towards neighbour, 248.
- Dying, Holy Communion administered to, 289.
- Dykes, Dr., on manner of performing Divine Service, li.
- Dymchurch, register at, on prohibited seasons for marriage, 263.
- Eadfrid, his gloss on the Evangelists, 31.
- Early Church, its witness to the principle of Ceremonial Worship, xlvi.
- Ears, opening or piercing the, 370.
- Earth cast on body at burials, 298.
- East, Turning to the, 7. 19.
- Easter, time of its celebration, [29]. 104, 105; error in tables, to find, [27]; festival, former extension to seven days, 105; its names, 104; notices given for its uniform celebration, 104; principal festival of the year in early Church, 103; Day, two celebrations in the Salisbury Use, 105; Anthems, Latin and English, 105; Psalms, 319. 392. 477. 479. 480. 484; Psalm, Sarum, 318.
- Easter Even "a high day" in the Jewish Ritual, 102; Baptisms on, in early Church, 102; ancient Collects and alterations, 102; Sarum Psalms, 318. 332. 333. 346. 349. 353. 388. 421.
- Eastern Church, its conservation of ancient customs and formularies, 68. 72; Liturgy of, 146; its prayers long and involved, 69; its regulations for vestments, lxxvii. lxxix; resistance to insertion of *Filioque*, 170; its form in Baptism, with possible origin, 211, n. 1; Form of Baptismal Renunciation, 222; uses Nicene Creed at Baptism, 223; Confirmation in, 252. 257, n. 1; Daily Morning Psalm, 320; Baptismal Office, 223. 225.
- Ecclesiastical censures, lxx.
- Ectene*, represented in our Offices, 46. 48. 167.
- Edgar, K., Canon of, on Comm. of Sick, 289.
- Edmund, K., his law of Marriage, 261.
- Edmund, St., [59].
- Edward, St., King of W. Saxons, [43]; translation, [49].
- Edward, Confessor and King, [57].
- Edward VI.'s First Liturgy *in extenso*, 202.
- Effect of Holy Baptism, 213.
- Egbert, Archbishop of York, his Confirmation Office, 252. 257; Excerpts of, on *Viaticum*, 289; Excerpts of, on burial, 294; on Spiritual Comm., 291.
- Egypt a type of Antichrist, 428.
- Ἐκκλησιασθήναι, Greek term for Churching of Women, 304, n. 1.
- Elborow on burial of dead, 298, n. 1; on veil at Churchings, 304.
- "Elect of the Elect" among our Lord's Disciples, 80.
- ELEMENTS, the outward visible signs or substances in the Sacraments, technically called *materies* or "matter."
- Elements, Oblation of, 174; offered by people in primitive Church, 198; delivery of, 189; remaining after Comm. of Sick, how to be disposed of, 291.
- Elizabeth, Queen, her measures to silence disputes, xxxiii.
- Elvira, Council of, on Lay Baptism, 212.
- Ely Cathedral, sculptures relating to St. Etheldreda, [57].
- EMBER seasons, the *Quatuor tempora* or four times in the year set apart for Ordinations, said to have been called *Quatember* from the Latin, and hence Ember.
- Ember Days, 63. 75. 92. 544.
- Emblems of Saints, 39—61.
- Embolismus, 6. 191.
- Emergency, Baptism in cases of, 211.
- Empire Spiritual, 319.
- "Endeavour themselves," illustrations of term, 256.
- Enemies of the Psalmist, of what typical, 322.
- "Engagement," substitute for ancient betrothal, 267.
- English Liturgy, its Gallican origin—revisions by SS. Augustine and Osmond, basis of present Vernacular Liturgy, 147.
- Entrance, Great and Little, 169. 173.
- Epact, meaning and use, [31].
- Ephesus, its importance as abode of St. John, 80; Liturgy of, 147. 225.
- Ἐφῶδιον, Eastern name for *Viaticum*, 289.
- Epiphanius, on Eunomian Baptism, 211; on Prayer for Dead, 301.
- Epiphany, as the close of Christmas-tide, 83, 84; Unity and fitness of Scriptures for, 84; 6th Sunday after, an addition of 1661, 87; 3rd Sunday after, Offertory sentence for, 86; of Christ as a Divine Healer of our infirmities, 86; Sarum Psalms, 351. 379, 380. 402. 414. 437. 451—453.
- Episcopate, Divinely instituted, 530; distinguished from Presbyterate *jure divino*, 566; called an Order by Isidore, 566; includes within it the Priesthood, 566.
- EPISTLE, the portion of Holy Scripture read before the Gospel in the Liturgy, generally taken from one of the Apostolic Epistles, sometimes from the Acts or Prophets.
- Epistle and Gospel read from "Jube," 307; and from a Lectern, 168.
- Epistles and Gospels, their arrangement, 70.
- Epistles, Ancient, at Consecration of Bishops, 570; at Ordering of Deacons, 549; at Ordering of Priests, 556.
- EPISTOLER, the minister who reads the Epistle and acts as sub-deacon at a celebration.
- Epitaph on two Infants, 81.
- Epitome of the Gospel, Ps. i.—iv., 321.
- Erasmus, possibly author of latter part of Catechism, 242, n. 6.
- Erle, Chief Justice, his decision respecting Chancels, [64].
- Escott v. Martin, case of, 213, n. 2.
- Escurial, Palace of, [53].
- Espousals, 267, n. 1.
- Essentials of Holy Baptism, 210. 226.
- Etheldreda, St., her history in Sculptures at Ely, [57].
- Ethelred, King, his Ecclesiastical Laws, 27.
- EUCCHARIST, the Christian sacrifice of praise and thanksgiving, wherein we "show forth the Lord's death till He come."

- Eucharist, its first celebration, liv; Power of Consecrating, when first expressly stated in Ordering of Priests, 539; conveys Divine Presence, 155; a Sacrifice for the benefit of the whole Church, 156, 192; a means of union with God, 157; a symbol, and a means, of union among Christians, 157; strengthening and refreshing the soul, 158.
- Eucharistia, a term applied to Holy Communion in Daye's transl. of Hermann, 217.
- Eucharistic Worship, the only distinctively Christian worship, [63]; preparation, Psalms for, xxvi., 349; xxxiv., 359; Sacrifice, its relation to Jewish Sacrifices, 155; its relation to the Sacrifice on the Cross, 155.
- Eudoxia, Empress, lvii.
- Eunomian form of Baptism, 211.
- Eunuchus, St., [55].
- Eusebius, Martyr of Alexandria, 78; what he records of St. Thomas, 130.
- Evangelical interpretation, Key to, 360.
- EVE or EVEN, the day before a Festival. [See VIGIL.]
- Evening Celebrations, condemned by Fathers, 161.
- Evens or Vigils, the distinction and reasons, [28].
- EVENSONG, the order for Evening Prayer, representing the ancient offices of Vespers and Compline.
- Evensong, its comprehensive meaning, lii; an anticipation of Rest, 35, 506.
- Evidence of a common early Formula, "A Rule of Truth," 18.
- Exactness necessary in adm. of Baptism, 226.
- Examination, Ancient, of Priests at Ordination, 558; by Bishop to precede Ordination, 541; in Consecration of Bishops, 571; of Sick person, 282.
- Examination for Orders, subject of, 542; days appointed for, 541.
- Examiners for Orders, 541; number of, 542.
- "Exapostelaria" and Collects, 68, 69.
- "Excellent things" in Ps. lxxxvii., 439.
- Excommunicate persons, Burial of, 293.
- EXCOMMUNICATIONS, forms of words by which notorious offenders are cut off from the privileges of Church membership.
- Excommunications, 171.
- Exeter, Bp. of, Speech on Marriage, 262.
- Exhortation in our office from "Order of Communion," 150; to Communion, Old English form of, 178; upon the Gospel in Bapt. Office, 220; to Sponsors after Baptism, 229; of Sick, ordered by ancient Canons, 280; previous to Marriage, 263; after Marriage, 273; Ancient, by Bishop at Ordering of Priests, 555.
- Exhortations in Communion Office, 176.
- Exorcism in Baptism, 94, 210; in Baptismal Office of 1549, 219.
- Expectation of the B. V. M., 133.
- Extreme Unction, 275.
- Fabian, St., [39].
- "Fair," its meaning as applied to linen cloth, 164.
- Faith, and superstition distinguished, 245; necessity of, 42-45, 245; St., [57].
- FALDSTOOL, the small kneeling-desk at which the Litany is sung or said; its use enjoined, 48.
- Falling sickness, Gospel used against, 210.
- Family prayer an imperfect substitute for Divine Service, [20].
- FAST, a time set apart for especial self-discipline and humiliation, and the practice of mortification. [See ABSTINENCE.]
- Fast before Easter, from the earliest Christian times, its duration varied, 90.
- Fasting enjoined before Holy Communion, 161; Homily on, 91; of the early Christians, its mode, 90; rules for practice of, 91.
- Fathers, Bishops anciently called, 568.
- Faulkner v. Lichfield, opinions of the Judges, lxxi.
- Feasts and Fasts, Tables and Rules for, 26.
- Felicitas, St., an African Martyr, 43.
- "Felo de se," burial of, 294.
- Ferial and Festival Lauds, Sarum, 399.
- FESTIVAL, a day set apart for the celebration of some great event connected with our blessed Lord or His saints, called also a Holyday.
- Festival, Christmas, its great importance in both religious and social life, 77; of three or seven days at Easter, 105.
- Festivals of our Lord, idea on which the whole cycle is founded, 83.
- "Fides Catholica," earliest title of Athanasian Creed, 41.
- Fifth of November Service, 578.
- "Fili David," an ancient Liturgical expression, 586.
- "Filioque" in Nicene Creed, 170.
- Final Court of Appeal, lxx.
- Fire of London Service, 579.
- First-fruits Offering, 3, 53.
- Five Prayers, The, after the Collects, when to be used, 25.
- Flagellants, their "baptism of blood," 211.
- FLAGON, the vessel used to contain the wine previous to the lesser oblation, sometimes used also in the consecration.
- FONT, the stone vessel which contains the water for Holy Baptism.
- Font, Benediction of, 209, 210, 222; blessed on Easter Eve, origin of custom, 216; proper position of, 217; to be emptied after Baptism, 225.
- Food of body, its action compared with that of Sacramental Food, 158.
- Forbes, Bp., on Nicene Creed, 171, n. 1; Eucharistic Sacrifice, 188, n. 2.
- Foreign Reformers, how far they influenced Prayer Book, xxvii-xxx.
- Foreigners thrust into important offices by Somerset, xxx.
- "Form" at Consecration of Bishops not found in early English Pontificals, 575; at Consecration of Bishops in the Greek Church, 575; of Vestments, lxxx.
- Forms and Ceremonies, xlvi; of Dean Granville for Private Confession, 283, n. 3; ordinary, 284.
- Formularies, Ancient, when found unsuitable, and why? xix; of the Church of England, always distinctive, xvii.
- Forty days of Lent, variously computed, 90.
- Fothergill, his Prayer Book in eleven vols.—collection of old English Service Books, vi; MS. on St. Barnabas, 136; MS. on Confirmation, 253.
- Founders and Benefactors, Psalms for, 518-520.
- Four meanings of Holy Scripture, 316.
- Fourth finger why ring finger, 269.
- France, King of, nominates Bishops by Concordat, 569.
- Freeman, Archd., on Gallican origin of English Liturgy, 147; on Gloria in Excelsis, 194; on likeness between Eastern Hymns and Western Collects, 68; on the 1552 Revision, xxxi; on Words of Institution, 187, n. 1.
- French Church, ancient Bapt. Office of, 217; early publication of banns in, 261; early Liturgy of, 147.
- French saints in the Calendar, 37.
- French translation of Prayer Book, 19, 586.
- Frequency of celebration of Holy Communion, 161; enjoined in English Church, 162.
- "Frères Cordonniers," their origin, [57].
- Frewen, Archbishop, xl.
- Friends and neighbours to be present at Marriage, 263.
- FRONTAL, the *antependium* or vestment that hangs around and in front of the Altar.
- Fulda, Abbey of, its Preces, 46, 53, 54.
- Furniture of God's House, should be reverent in character, li.
- Gabriel the Archangel, his day, 141.
- Gallican Liturgy, xviii, 147; Mass for St. Stephen's Day, 79; origin of Prayer in Benediction of Water, 224, 225, Orig.; ritè of Confirmation, 256; version of Psalters, 315.
- "Gang Days," 111.
- Gardiner, Bishop, accepted the Prayer Book xxx.
- Garter, Order of, [45].
- Gates of Brass and Iron, 342.
- Gauden, Bp., on Black Rubrics, 199.
- Gawdie, Sir F., case of, 258, n. 2.

- Γεγέννηται, κ.τ.λ., explained, 245.
- Gelasian and Gregorian Sacramentaries, 24—27.
- Gelasian Baptismal Office, on Deluge, 218; interrogatories in, 222; Sacramentary, rule for Processional Litanies, 47.
- Gelasius, Reconc. Pœnit., 285, marg.
- General Assembly of 1616, and Scottish Liturgy, xlv.
- General Confession, how to be said, 3; Thanksgiving, its authorship, 66.
- "General," &c., sense of, in 16th and 17th Centuries, 249.
- "Generally necessary," meaning of, in Catechism, 249.
- George, St., his cross united with those of SS. Andrew and Patrick in the national ensign, [45].
- George I., Litany at his Coronation, 48.
- German origin of Prayers in Bapt. Office, 218—221; use of *Media Vita*, 297.
- Germanus on Gallican Liturgy, 148.
- Gestures in Divine Service, li. 3. 7.
- Gibson, Bp., on use of Burial Service, 293.
- Giles or Egidius, St., [53].
- Glastonbury Prayer Book of Pollanus, 167.
- Gloria in Excelsis, 193; position of Priest at, 193, n. 1; its possible origin, 193; expanded form, 194; position of, in Liturgies, 194; limitation respecting its use, [20].
- Gloria Patri, Variations in, 7.
- Godfathers and Godmothers, number of, 216; mouth-pieces of child, 224. 246.
- "Godly discipline," 309.
- "God's help" invoked, a form of oath, 246; "holy will and commandments," 245.
- "God's board," an ancient designation of Altar, 178.
- Gold and silver given at Marriage, 268.
- Golden Numbers, [29]; Litany, word "buxomnes" in, 267, n. 6; Rose, 94.
- Good Friday, its various names, 100; how anciently observed, 100; the hours of, illustrated, 100; how observed in Eastern Church, 101; churches hung in black, 101; Psalms, 342. 370. 388. 408. 439; Sarum Psalms, 342. 349. 367. 370. 388. 395. 419. 449. 483. 497. 513—515.
- Good Physician, manifestation of His power, 86.
- Goodrich, Bp., reputed author of part of Catechism, 242.
- GOSPEL.—1. The history of the Life of our Lord as recorded by the Four Evangelists. 2. A portion selected from this history, appointed to be read in the Liturgy.
- Gospel, 70. 163; The, found in the Psalms, 317; for the Circumcision, Rubric after it, 83; in Bapt. Office, 220.
- Gospels, Ancient, at Ordering of Deacons, 549; at Ordering of Priests, 557; at Consecration of Bishops, 568.
- Gospels and Epistles later than essential portions of Liturgy, 146; changes in them, 71.
- GOSPELLER, the Minister who reads the Gospel, and acts as Deacon, at a Celebration.
- Goulburn on Communion Office, 70.
- Gown, once commonly used in preaching, 172.
- Grace, what it is, 158; Collect for, Gregorian and Roman forms, 25; prefigured by natural provision, 521.
- Gradual Psalms, 496—506.
- Grant on the Bills of Mortality, [14].
- Granville, Dean, his Office for private Confession, 284, n. 3; anecdote about Scottish Liturgy, 582.
- Great Sabbath, 102.
- Greater Festivals, their central position in a series of days, 72.
- Greek Ch., burial custom in, 298; Prayer for Dead in, 301.
- Greek original of Preface in Comm. Office, 182; terms connected with H. Eucharist, 153; words in *Kyrie* indicative of Eastern origin, 167; version of Prayer Book, [18].
- Gregory, St., his Sacramentary, what it represents, xviii; his revision of Roman Liturgy, 146; the great originator of mission to England, [43]; advice to St. Augustine, xviii; Proper Preface for Circumcision, 83; on Churching of Women, 304; reformer of Church music, lvii.
- Gregorian chants in Merbecke, lxi; Gregorian music, lviii. [43]; difficulty of adapting it to English words, lxi.
- Gregory Nazianzen, on Choir veil or screen, xlix; on Private celebration, 290.
- Gregory, of Nyssa, on trine immersion, 211.
- Gregory of Tours, on his predecessor Perpetuus, 73; Hist. Francor., quotations from, 46; and Gregory the Great, on Lord's Prayer, 191.
- Grindal, Abp., his order to use Communion Service on certain Sundays, 308; his order to read Ep. and Gosp. from Chancel-screen, 307; on Churching of Women, 304.
- Gueranger on corruptions of Roman Liturgy, 150.
- Guidetti, coadjutor of Palestrina in revising Church Song, lix.
- Gunning, Bp., his instrumentality in the restoration of the Prayer Book, 65; on Black Rubric, 199.
- Gunpowder Plot Service, 578.
- Habit of Bishop elect at Consecration, 568; proper for Candidates for Deacon's Orders, 546; proper for Candidates for Priest's Orders, 554.
- Hale's Precedents, Cases of Churching of Women in, 304; on Godly discipline, 309; referred to on hours of Marriage, 262.
- Hallelujah, 405; its first use in the Psalms, 464; in Prayer Books of 1549—1552, 1637, 1661, 7; the Great, 194. 479.
- Hammond on Catechizing, 243.
- Hampton Court Conference, 4; an effort to convince Non-conformists, lxxviii; abruptly broken up, xxxvi; on "lawful minister" of Baptism, 213.
- Hands to receive the Elements, 190.
- "Hard Sayings," illustrated, 428.
- Harvest Thanksgiving, admirable Collect for, 110.
- Harvey on the Creeds, 19. 41.
- Hawaiian Version of the Book of Common Prayer, xlv.
- Head of Child to have water poured on it, 226.
- "Healing," Note on Office for, 580.
- Heaven, The Worship of, l.
- Heber, Bp., on Prayer for the Dead, 381.
- Hebrew Chants, Melody to 51st Ps., lvi.
- Hellenism prepared the World for Christianity, lvi.
- Heman and Jeduthun, Choristers, liii.
- Hengstenberg on the Psalter, 313.
- Hereford Use in Espousals, 267.
- Heresies, cause of many, 428.
- Hermann, Archbishop, of Cologne, Ritual Reformer, xxi; his Consultation, xxvii. 181, 182; his form of Marriage Admonition, 265; Catechism in, 242, n. 1; origin of catechizing at Confirmation, 215, Orig., 255; Daye's transl., 256, Orig.; on Seasons for Baptism, 216; Bapt. Exhortation in, 220; Bapt. Collect in, 221; on Infant Communion, 217; Absolution in, 284; the probable origin of joining hands in Marriage, 270; Litany in, xxi.
- Hesychius in St. Leo, quoted on Consumption of Elements, 291.
- Heurtley's Harmonia Symbolica, 17. 36. 223, n. 1.
- Hickes on Eucharistic Sacrifice, 188, n. 2.
- Hickman, Mrs., Touching anecdote of, about Reformation Bapt. Office, 210.
- Hierapolis, Martyrdom of St. Philip, 135.
- Hilary, St., of Arles, [39]; commends faithfulness of British Bishops, [39]; reputed author of the Athanasian Creed, 41; on the Psalms, 316; on Christ's rest in the Church, 505.
- Hilary, St., of Poitiers, reputed author of part of Gloria in Excelsis, 194.
- Hilary Term of Law used to begin on the Festival of St. Hilary, Dec. 18th, [39].
- Hilsey, Bishop, his version of the Athanasian Creed, 41; his Primer, 1539, 22.
- History, Spiritual, its central point, 335.
- Holt, Lord Chief Justice, on change of name, 258.
- Holy Apostles, their commemoration, [37].
- Holy Bible, always publicly read, [15].
- Holy Communion, an ancient and Scriptural phrase, 163; its various designations, 145; originated by our Lord, and asso-

- ciated by Him with Ancient Rites, 152; doctrine of, 151; as a Sacrament, 152; as a Sacrifice, 152; may possibly supply omission of Baptism, 240; office, 68. 163; notice, or warning of, 171; on Good Friday, 101; at Burials, 295; at Burials, why proper, 296; at Burials, Office for, 303; at Churchings, 306. [See Communion.]
- Holy Cross Day, [55].
- Holy Days after Christmas, The three, 78; publ. of Banns on, 262, n. 2; bidding of, 171; Minor, [39—61].
- Holy Ghost, how given to the regenerate, 221; *Invoc.* of, in all Confirmation offices, 257.
- Holy Innocents, early notices of, 81; muffled peal on, 81; ancient Collect for, 81.
- Holy Sacrament, reserved in the Eastern Church, 99.
- Holy Scripture, Coincidences in ancient and present mode of reading it, [23]; its continuous reading, [25]; responsory system of reading it, [24]; its proper use and mode of interpretation, 43.
- Holy Thursday, 111.
- Holy Week, or Great Week, 96; its strict observance, official example of the emperors, 96.
- Homily, pre-reformation, on Confirmation, 253.
- Homily of Common Prayer, &c., on number of Sacraments, 249; of Repentance, on private Confession, 283.
- HOOD, a badge of academical status worn by graduates over their surplices. See Canon 58.
- Hooker, on the Divine Service, lii, note; on death unto sin in Baptism, 214; on iteration of Baptism, 217; on Lay Baptism, 212; on Marriage, 274; on delivery of money in Marriage, 269; on Offerings at Churchings, 306; on Puritan obj. to Christian burial, 296.
- Hooper, Bp., on sense of word "general," 249.
- Hope, Expressions of, in Bur. Office explained, 299.
- Horace on casting earth on dead body, 298.
- Horn Books, engraving of one, xxiii; introduced for the poor, xxiv.
- Hornby, register at, on prohibited seasons for Marriage, 263.
- Horsley, Bp., on Invocation of Holy Ghost, 187; on Scottish Liturgy, 192.
- Hosanna in Preface displaced, 1552, 183.
- Hosanna Sunday, 96.
- Hour for celebration of the Holy Communion, 161.
- Hours of Prayer, how observed by Apostles and early Christians, [62]; seven condensed, xxviii.
- House of Commons, amendments to Act of Uniformity, xlii.
- House of God, what it is, 1.
- Housel, Old Eng. term for H. Euch., 289.
- Hugh, St., [59].
- Human Nature, its perfect ideal personified, 318. 332.
- Humble Access, Prayer of, 185.
- Hyde, Lord Chancellor, corrects an error in MS. of P. B., xlii.
- Hymns and Hymnals, Latin and translations, 71.
- Hymns for Christmas-tide, 77; for St. Stephen's Day, 79; St. John the Evangelist, 80; the Holy Innocents, 81; for the Circumcision, to be sung till the Epiphany, 83; after the Octave of the Epiphany, 85; for daily use, the first and second weeks in Lent, 93, 94; for Passion Sunday, and daily use to Maundy Thursday, 96; for Low Sunday and Season, to be sung daily, 107; for the Ascension, to be sung up to Whitsunday, 111; from Trinity to Eve of Advent, 115; for Whitsuntide, 113; for St. Andrew and other Apostles, 130; their proper position in Divine Service, lxiv; sung by Christ, 480.
- Hypapante, Eastern name for the Purification Festival, 131.
- Hypothetical form in Baptism, 213.
- Idiots to be baptized, 230. 238.
- Idoltrous ceremonies, the origin of "pomps," 222.
- "I do," in Confirmation, 256.
- Ignatius, St., lvi; on "one Altar," 158; on Matrimony, 261; Tradition respecting Anthems, lvi.
- "Illatio," Gallican and Mozarabic term for Proper Preface, 185.
- Ilberis, Council of, on Lay Baptism, 212.
- IMMERSION, the dipping into the water of recipients of Holy Baptism. Affusion is now the usual practice.
- Immersion, Baptism by, 209. 211; the Apostolic mode of Baptism, 209; disuse of, necessitates special precautions, 226; trine, 211.
- Impediments of Marriage, 262. 265.
- Imposition of hands in Confirmation, 251, 252; of hands sometimes a mere elevation, 252.
- Imprecations of Psalms, 362. 410, 411. 475. 513.
- Incarnation of our Lord—its fruits in the three kinds of Saints, 78; in connexion with the Martyrs, 78.
- Incense, its use in ancient Church of England, 33; at Gospel, 169.
- Inclination, Prayer of, in Eastern Liturgies, 186.
- "Incomprehensible," its twofold meaning, 43.
- Indulgence Sunday, 96.
- Indwelling of the Holy Ghost, 506.
- Infant Baptism in Primitive Church, 210. 215; Confirmation and Communion, 217. 251.
- Infants, Baptism of, 215.
- Infection, precautions against, 292.
- Infidels, burial of, 293.
- Infrequent Communion of Laity, 150.
- "Inheritor of the kingdom of Heaven," Scriptural term, 245.
- "Inhumatio Defuncti," 293.
- Injunctions on Catechizing, 242, 243.
- Injunctions of Edward VI., xxv.
- Injunctions and Advertisements of Queen Elizabeth, lxvi, lxvii; on wafer bread, 198; and 18th Canon on reverence, 20; on age for Communicants, 253.
- Innocent, St., on Roman Liturgy, 146.
- "Innocents," i. e. idiots, regenerate in baptism, 230, Orig.
- Innovations connected with Holy Eucharist in Mediæval times, 150.
- Institution of a Christian Man quoted, 230.
- Institution of Holy Eucharist, 145. 152, 153. 163, n. 2. 176.
- Interlinear Translations of Office books, xxiii.
- Intermediate state typified in 130th Psalm, 503.
- "Interpretation Clause" of Prayer Book, lxx.
- "Interpretations and Considerations" of Queen Elizabeth, lxvii.
- Interrogation of Sick on Articles of Faith, 281.
- Interrogation preceded Baptism, 222.
- Interrogations in ancient Baptismal Offices, 210; represented modern Catechism, 241; formerly addressed to child, 224; in our Baptismal Office represent Apostolic practice, 222.
- Interrogatories from Sarum "Ritus Baptizandi," 222, Orig.
- Introduction to the Liturgy, 145.
- Introductory Rubrics to Baptismal Office, 215.
- Introductory Service to Baptism, 217.
- INTROIT, the Verse, Psalm, or Hymn which is sung as the Priest goes to the Altar.
- Introit, 71. 149. 200.
- Introits—their selection—ancient names, 71; a list as arranged in the first English Prayer Book, 68; given under each Sunday and Holyday, 73; for Advent, their spirit, 73; to Communion at Ordination Service, 1549, 556.
- Invention of the Cross, [47].
- Inventories of Ornaments, made in 1552, lxxii; of Vestments and Hangings, lxxvii.
- Invitation to Communicants, 180.
- Invitatories to Venite, 7.
- Invocation of the Holy Ghost, 187; in Baptism and Liturgies compared, 221.
- Invocation, Prayer of, in Confirmation Office, 257; of Trinity in Baptism, 209; of Angels and Saints, 47.
- Irenæus on Fasting, 90; on Infant Baptism, 215.
- Irish Clergy, their use of Burial Service, 293.
- Irish Common Prayer Book, xlv. 585.
- Irish Communion Book, 6th Century, 70.
- "Irregularity;" sense of word in Canon Law, 283, n. 2.
- Isidore on Fonts, 211.

- Israel, its History typical, 465.
 Italic Version of Psalter, 315.
 Iteration of Baptism, 217. 232, 233.
- "Jah," in 69th Psalm, 405.
 James, St., the Great, 139.
 James, St., the Less, 135; Liturgy of, 146; its prayer for living and departed, 156; Psalms before Communion, 182.
 James I., King, and Liturgy for Scotland, 580.
 Jasper, its symbolism, 407.
 Jebb's Choral Service, 59.
 Jenner, Sir H., on Prayer for Dead, 301.
 Jerome, St., and the Latin Vulgate, [55]; his three versions of the Psalter, 315; Lectionary, its Epistles and Gospels, 68. 70. 295, 296; on Advent, 72; on the Epiphany, 83; on Lay Baptism, 212; on Arian Baptism, 211.
 Jerusalem, Liturgy of, 146.
 Jesuits, their Symbol, [53].
 Jewell, Bp., on death unto sin in Baptism, 214.
 Jewish worship, its influence on Christians, [62]; origin of Churching of Women, 304.
 Jews, The, their state before the destruction of Jerusalem, 94; a great conversion of them foretold, 397; their enmity and rejection foretold, 393; their sin and punishment foretold, 403.
 Jews and Gentiles changing places, 396. 481.
 Job a type of Christ, 458.
 John, St., the Baptist, Nativity of, 136; his greatness and power as a Prophet, 136, 137; Advent proclamation of Christ, 74.
 John, St., the Evangelist, his relationship to our Lord, 79; his two escapes from death, his death at Ephesus, 80; Ante Portam Latinam, [47]; Liturgy of, 147.
 Johnson on Euch. Sacrifice, 188, n. 2; Canons referred to on Confirming by name, 258, n. 2; referred to for Marriage Law, 261; referred to on publicity of Marriage, 262; referred to on Catechizing, 241.
 Johnson, Dr., his practice of praying for dead, 301.
 Joining of hands in Marriage, 270.
 Joseph a type of Christ, 466.
 "Jube," a lectern on Chancel-screen, 307.
 Jubilate, seldom to be used, 17.
 Judas, in 109th Psalm, 474.
 Judaism has become heathenism, 396.
 Judaizing Christians, troublesome to the Early Church, 104.
 Jude, St., 143.
 Justin Martyr, his account of Celebration of H. Eucharist, 146, n. 5; his notice of Christian Hymns, iv; on Sursum Corda, &c., 183; on Amen, after Prayer of Consecration, 189; early reference to Gloria Patri, 7; on Infant Baptism, 215; on Comm. of Sick, 239.
 Juxon, Archbishop, xl.
- Kalends of January and Feast of the Circumcision, 82.
 Katharine, St., [61].
 Katharine, Queen, her Prayers and Meditations, 26.
Κατήχησις, meaning of, 241, and n. 1.
 Keble on Eucharistical Adoration, 154. 188.
 Kempe v. Wickes, case of, 293.
 Ken, Bp., on Catechizing, 243.
 Kennett, Bp., his MS. notes on P. B., 258.
 "Keys of the Kingdom of Heaven," 138.
 Key-stone of the Temple, 334.
 Kingdom of Christ, 414.
 King's Evil, Office for, [57]. 580.
 Kingship of Christ, 453. 477.
 Kiss of Peace, 149, 150. 200.
 Kneeling, Bishop Cosin's note on, 3; declaration on, 199; posture of celebrant in receiving, 189; posture in Marriage, 269; the proper posture in Adult Baptism, 240.
- Knights of the Garter, service at Windsor, &c., [45].
 Knox, his Book of Common Order, xlv.
 Knox, John, saying of, 51.
 Krazer de Liturgiis, xlviii.
 Kyrie Eleison, said in Greek, 21; in Communion Office, 167; expanded form of, 167.
- "Laither," meaning of, 267, n. 4.
 Laity, Daily attendance of, [63]; their part in offering of Eucharistic Sacrifice, 155—188.
 Lambert, St., [55].
 Lammas Day, [53].
 Lancashire, burial of Roman Catholics in, 293.
 Languages and Dialects into which the Prayer Book is translated, xlv.
 Laodicea, Council of, on Lenten Marriages, 263.
 Lasco, or Laski, John à, xxvii. 4.
 Last Supper confounded with Institution of Holy Eucharist, 163.
 Lathbury on State Services, 578.
 Latimer, Bp., on meaning of word "general," 249.
 Latin Prayer Book, [18], [19]. xxxv. 586; of 1560, Saints commemorated in, [36].
 Latin Service for Convocation, 580.
 Latin Version of latter part of Catechism, 242.
 Latter part of Catechism, its history, 242.
 Laud, Archbishop, and former Collect for Easter Even, 102; and the Scottish Prayer Book, xlv. 185. 580, 581.
 "Lawful authority," 27.
 Lawrence, St., [53].
 Laxity tolerated by some Bishops, xxxv.
 Lay Baptism, 211; allowed to be valid, 213; discouraged, 231, Orig. and n.
 Laying on of hands by Bishop in Ordering of Deacons, 551; by Priests in Ordering of Priests, 562; in Confirmation, 251.
 Lazamon's Brut, referred to, 267, n. 4.
 LECTERN, the desk from which the Lessons are read.
 Lectern for Epistle and Gospel, 168.
 Lecterns for Music-book and for Lessons, 168.
 Lectionary, changes made in the Salisbury Use, [25].
 Lectionary of St. Jerome, commemoration of Apostles, 129; SS. Peter and Paul, 137.
 Lectons, Scripture, how to be "read or said," lviii. lx, lxi.
 Legal obligations of Canons of 1603-4 and 1640, lxix.
 "Legatus natus" of Pope, 262, n. 1.
 Legends of Saints, SS. Hilary, [39], Prisca, [39], Anne, [51], Blasius, [41], Benedict, [43], John Baptist, [53].
 Lent, different usages as to its duration, 89, 90; abstinence other than from food, 81.
 Leo, Emperor, Churching of Women under, 304.
 Leo, St., his Epistle to the French Bishops, 42; on Holy Innocents, 81; on trine immersion, 211.
 Leonard, St., [59].
 Leonardo da Vinci, his picture of Last Supper, a means of propagating error, 163.
 LESSONS, portions from the Old and New Testament, read at Mattins and Evensong, and in the Burial Service.
 Lessons, The, not always Holy Scripture, [23]; proper for Holy-days, [25]; how anciently read, [23]; system established in 1549, [25]; in ancient Baptismal Offices, 209; in Burial Office, 295.
 L'Estrange on form in delivery of Elements, 189.
 Letters dimissory, 541.
 Levitical Benediction, ancient Irish, Gallican, and A. S. uses of, 287.
 "Liber Festivalis," xxv; its use of word "worship," 269.
 Library of Anglo-Catholic Theology, Works of Bishop Cosin, xli.
 Library of S. J. C. Oxon., MS. De Vis. Inf., 280; of Trinity Col. Cam., Trilingual Version of the Creed, 86.
 Licence for Marriage, 261; Special, 261, 262, n. 1.
 Lights on the Altar, 159.
 Lighted taper used in Baptism, 210. 222.

- Lighted tapers at Gospel, 169.
 Lightfoot on Jewish Baptism, 208.
 Lincoln, Diocese of, petition to King James for total abolition of Prayer Book, xxxvi.
 Linen cloth for covering Elements, 191; its use and symbolism, 159. 164. 191.
 Lion, The, a typical enemy, 323.
 Litaneia, use of the word by St. Basil, 46; its technical sense, 46.
 Litanias, Major, Minor, Septena, 47.
 Litanias Septena, 209; septiformis, 209, n. 5.
 Litanies, their general acceptableness to the people, 47; oldest Western Use, 57; proper, of Western Use chiefly, 46.
 LITANY, a "General Supplication" in the form of short petitions, to which the choir and congregation make responses.
 Litany in English, 1544, xxi, xxii; its mediæval use, 48; its excellence, testimonies to, 48; the simple Chant generally used very old, lx; published by Cranmer with musical notation, lx; Canon XV. on, [20]; as a separate service, 48. 175; place for singing it, 48; lesser, in Vis. of Sick, 277, 278, n.; use of, in Ordering of Deacons, 547; in Ordering of Priests, 555; in Consecration of Bishops, 570; additional note on, 586.
 Litera Dominicalis, [16].
 Littledale's Offices of Eastern Church referred to, 257.
 Liturgical studies, their gradual advance, vi.
 Liturgies, Oriental, three Great, 28; ancient, on Words of Institution, 187.
 LITURGY, the Eucharistic Office. The term is sometimes applied loosely to the whole of the Book of Common Prayer.
 Liturgy, inexact use of term, 145, n. 3; its primitive origin, 145; its divisions, 68; of the Roman and Gallican Churches, xviii.
 Liturgy of St. James, the Benediction, 28.
 Liturgy of St. Mark, Ps. xlii., 373; a Prayer for the Sovereign, 27.
 Lombard, Peter, on Sacraments, 250.
 Longley, Abp., on burial of unbaptized, 293; on Reservation for the Sick, 290.
 Looking up to heaven in act of Consecration, 187.
 Lord-Lieutenant of Ireland, Prayer for, 585.
 Lords, House of, vote thanks to Convocation for Revision of Prayer Book, xli.
 Lord's Prayer, specimen of old versions, 37; use with special intention, 6. 22; Versions of the 7th and following centuries, 31; anciently part of Introductory Service before Introit, 165. 200; a sort of Antiphon to Communion Office, 165; at greater Oblation, 191; in Bapt. Office, 220; after Baptism, 228; in Vis. of Sick, 278; expositions of, 6. 31, 32. 248; Sir Rd. Baker on, 6; Bp. Andrewes's Paraphrase, 6; Paraphrase by Keble, 32; familiar to mediæval people, 30.
 LORD'S SUPPER, a term applied to the Holy Eucharist. It is an elliptical expression, meaning *Sacrament* of the Lord's Supper.
 "Lord's Supper," a pre-reformation expression, 163; or "Holy Communion" Office, 163.
 Lord's Table, 158; a term properly applied to the Altar, 164.
 "Low Church party," official attempt to reconcile them, xxxviii.
 Low Sunday, 107.
 Lucian, St., [39].
 Lucy, St., [61].
 Luke, St., 142.
 Lushington, Dr., on use of Burial Service, 293.
 Luther, his Litany, xxi; his transl. of a Prayer in Bapt. Office, 218; his Version of sequence of Notker, 297; prayed for dead, 301.
 Lyndewood on Baptismal Affusion, 226, n. 1; list of Church ornaments, lxxiv; Prov. Const., on Visitation of Sick, 275.
 Lyons Pontifical, on Confirmation Address, 256.
 Machutus or Malo, St., [59].
 Machyn's Diary, 1560, lxiii.
 Magdalen College, Oxford, bells rung on Christmas Eve, 103.
 Magi, traditions respecting them—their relics—their names, 84; Royal Memorial of their offering, 84.
 Magnificat and Cantate Domino compared, 34.
 Magnificat, The, special reverence shown to it, 33; Puritans desired to banish it, 33.
 Mahometanism, Probable cause of, in India and the East, 94.
 Maledictions of the Psalms, 410, 411.
 Mamertus, his Rogation Fast, 46.
 Man, The Righteous, 318. 359.
 Manchester Cathedral, custom observed there, 7.
 Manichæans, their rejection of Water, 210.
 Manifestations of Christ's glory, three commemorated at Epiphany, 83; in the Temple, 84; on Sundays after Epiphany, 86, 87; still going on by miracle, 86.
 MANIPLE, a vestment like a short stole, worn on the left arm by the sacred Ministers at the Celebration of Holy Communion. [See Ecc. Vestments, Plate II.]
 Manna a type of Holy Eucharist, 151.
 Mansfield, Lord, on Publication of Banns, 262.
 Manual, Occasional Offices of, xxviii.
 Margaret, St., [51]; sometimes called St. Marina, [51].
 Mark, St., his Labours and Martyrdom, 134; Liturgy of, 134. 146; Psalms before Communion, 182.
 Marriage, Scriptural and Patristic view of, 261; a Sacrament, 261; proper, 268; impediments of, 262; licences, 261; hours for, 262; forbidden seasons for, [28]. 262, 263; Psalms, 501; by Deacons not authorized, 264; Concluding Prayers of Service, 272.
 Marshall's Primer, 4.
 Martene on Bapt. Offices, 220; his collection of ancient writers, [36]; on Confirmation Addresses, 256.
 Martin, St., his translation, [51]. [59].
 Martyr, Peter, placed at Oxford by Somerset, xxx.
 Martyrs in the age of persecution, 37; specially connected with Ch. of England, [37]; all the, Festival of, 143; Many, Sarum Psalms, 332, 333. 341. 346, 347. 359. 363. 483; three kinds, commemorated on three days after Nativity, 78.
 Martyrdom of our Lord life-long, 78.
 Martyrdom of King Charles I., Fast for, [39]; Service, 578.
 Martyrdoms recorded in Scripture, 136; both foretold and commemorated, 429.
 Martyrology of Bede, [36].
 Mary, B. V., her true sanctity, 134; Sarum Psalms for her Festivals, 339. 346. 377. 379. 439. 452—454.
 Mary Magdalen, St., [51].
 Mary, Queen, her proclamation superseding the Reformed Prayer Book, xxxiii.
 Maskell's Monumenta Ritualia, xxvii. [63]; on bidding of Prayers, 21; on Vis. of Sick, 280, 281.
 MASS, the old English designation of the Sacrament of the Holy Communion.
 Mass, explanation of term, 145; how the term fell into disuse, 163; ordered to be "altered into a Communion," 150.
 Mass of Holy Ghost, sung at Consecration of Bishops, 575.
 Masses, Solitary, 197.
 Massingberd's Lectures on P. B., 210.
Μαθηματικά, its full meaning, 208.
 Matthew, St., 140.
 Matthias, St., 133.
 MATRIMONY, HOLY, Christian Marriage, as solemnized by the Church.
 Matrimony, Solemnization of, 261; Psalms for, 404. 501.
 MATTINS, the Order for Morning Prayer, representing the ancient Offices of Mattins and Lauds.
 "Mattins," beginning of, in ancient Sarum Use, 1; in 1549, 6; to be said before Celebration of H. C., 163.
 Maundy Thursday, 408; its various names, 98; ancient Offices for, 99; Sarum Psalms, 411, 412. 414. 416. 418. 420—422. 483. 497. 513—515.

- Maundy royal, Office for, 99.
- Maximin, burnt a church full of Martyrs, 77.
- Maximum of ceremonial to be sought from tradition, 258.
- Maximus of Turin, De Adventu Domini, 72.
- Maxwell, Bp., and the Scottish Prayer Book, 581.
- Mede, on Christian Sacrifice, quoted, 158.
- Mediæval Bishops, their neglect of Confirmation, 258.
- Mediæval Church of England, H. C. at burials in, 296; processional Psalms at funerals in, 297; how its Services were accumulated, xxix; Liturgy of, 149.
- Melchisedek on Confirmation, 253.
- Melchizedek's offering, 152.
- Melitus, Bishop of Sardis, on Paschal Festival, 104.
- "Member of Christ" a Scriptural expression, 244.
- MEMORIAL COLLECT, that of the less of two coincident holydays, used after that of the greater by way of commemoration.
- Memorie, and Memorial Collects, 26. 65. 168.
- Menard, on Litanies in Baptismal Office, 209, n. 5.
- Menard's notes to Greg. Sac., 285, marg.
- MENSA, the slab of stone or wood used as the surface of the Altar or Lord's Table.
- Merbecke's Prayer Book noted, lxi; arrangement of Burial Service, 294.
- Meton, the Athenian, his Cycle of the Moon, 80.
- Metrical Hymns, early use by and against heretics, lvii; Cranmer's wish to retain those of Sarum, lxii.
- Metrical Hymn Music, its Grecian origin, lvi.
- Metrical Psalms, when introduced, lxii.
- Metropolitan, early existence and title of, 567; by whom consecrated, 567; cities, definition of, by Tertullian, 567.
- Mi Carême, The French, and festivity at Midlent, 94.
- Michael, St., two festivals anciently in his honour, 141; peculiarity in position of churches dedicated to, 141; Sarum Psalms, 332, 333. 339. 346. 359. 452, 453. 459. 510.
- Michaelmas, 141.
- Micrologus, on Collects, 69.
- Midwives licensed to baptize, 212, n. 1.
- Milan, Church of, its Liturgy, 147; Church of St. Ambrose at, its music, lvii; Oblation of Elements at, 198; Council of, on Visitation of the Sick, 275.
- "Millenary Petition," xxxvi.
- "Mincha" of Temple Service, 152, 153.
- Minimum of Ritual in present Rubrics, 191. 258.
- MINISTER.—1. The officiant at the Holy Eucharist or other Services. 2. Clerics or laymen acting as assistants.
- "Minister," Bp. Cosin's note on the term, 2; its technical meaning, 2. 213, n. 1; term applied to Bishop, 258, and n. 1.
- Minister of Baptism, 212. 239.
- Ministers, at the Altar, 160; quality of such as are to be made, 544.
- Ministry, Three orders of Apostolical, 540; succession of, from our Lord, 530; succession of, from the Apostles, 531.
- "Ministry of God's Word," meaning of, 177.
- Minors, Marriage of, 262.
- Minor Holydays, [89]. [62].
- Minor Saints, their representations in art, [39]. [61]; All Souls, SS. Thomas and Patrick in Calendars of Stationers' Company, [37].
- Miracles, "The beginning of," 85.
- Miracle of the Loaves, its mystical character, 95.
- "Mirror of our Lady," on Nicene Creed, 171; altered form of Gloria in Excelsis in, 195; on the Sanctus, 183; on Lord's Prayer at Greater Oblation, 191; on Triple Repetition of Lesser Litany, 22; on the word Collect, 69; on Reverent Gestures in Praise, 7. 12; on "Synge rede ond say," ix.
- Missæ, explanation of term, 145, n. 1.
- "Missæ Sicca," 197.
- "Missæ Sponsalium," 274.
- "Missæ Votiva" at Marriage, 271.
- "Missæ pro Rege et Regina," 27. 168.
- Missal of Sarum or Salisbury, xxviii. 68. 149. 184. 200.
- Miss. Gallic. Grimold., 287, marg.
- Miss. Bobiense, Muratori, 228, Orig.
- MITRE, the covering for the head proper to the Episcopal Order: it represents mystically the cloven tongues on the heads of the Apostles. [See Ecc. Vestments, Plate II.]
- Mitres and staves of Trelawny, Mews, and Laud, 574.
- Mixed Chalice, its authority and symbolism, 173.
- Monasteries, Ritual effects of their suppression, xix, xx.
- Monday in Holy Week, its distinctive memorial, 97.
- Monica, St., mother of St. Augustine, [53]; her dying request, 295.
- Monotone, different uses, lviii; in reading the Lessons, 9.
- Monotonic recitative, the basis of plain song, lviii.
- Monophysite Liturgy of St. James, 146.
- Moral Law binds Christians equally with Jews, 247.
- "Moriens," meaning of, 407. 439.
- Moses a type of Christ, 469.
- Mother of our Lord and "Mother of us all," 33.
- Mourning, its tokens used in Lent, 91.
- Mozarabic, a form of the Gallican Liturgy used in Spain, 147; Proper Prefaces in, 185; Liturgy, Epistle for Epiphany 4th, 87.
- Muratori, Reconc. Pœn., 285.
- Music, Ancient Christian, lvi; of Mediæval Church, lii; remodelled with the Services, lix; among modern Jews, lvi.
- Musical Intonation in Divine Service, li; character of Services retained, lxi; scales, their Grecian names, lvi; scales of St. Ambrose and St. Gregory, lvii; notation of Proper Prefaces, &c., 185.
- Mutual Consent, 265; Salutation, 22. 149. 200.
- "Myroure of oure Ladye," a Ritual Commentary, xix. 6.
- Mystical Body of Christ, how formed, 321.
- "N. or M.," explanation of, 244.
- Nadabar, martyrdom of St. Matthew, 140.
- Name, of Jesus, [53]; Christian, used in Catechism, &c., 244; changed in Confirmation, 258, n. 2; children confirmed by, 258, n. 2.
- Names given in Baptism, 209.
- Naples, King of, allowed to nominate to 24 sees, 569.
- "Natalis Eucharistica," 98.
- Nathanael, whether identical with St. Bartholomew, 139.
- National Flag, crosses of, [45].
- Nativity, of our Lord, its date, 76; of B. V. M., [55].
- NAVE, the central portion of the body of church. [See AISLE, CHANCEL.]
- Navy, The, its relations to the Church, lxxviii. 527.
- Neale on Primitive Liturgies, 148; on Words of Institution, 187, n. 1; on the Eastern Hymns, 69; on the Eastern mode of observing Epiphany, 84.
- Neale's Commentary on the Psalms, 59. 314; Hist. Eastern Church referred to, [63]. 222, n. 2; Liturgiology, essay on Liturgical quotations in N. T., 70.
- Neglect of Public Worship fineable, [5].
- Nero's persecution foreshadowed, 391.
- Neva, waters of, blessed, 218, n. 2.
- New birth in Baptism, 214.
- New Creation, the Lord of it, 85.
- New Names, Three of the Apostles distinguished by, 80.
- New Style, [30].
- New Year's Day, a conventional observance, 83.
- Nicæa, Council of, on Lay Baptism, 212; decree for ruling Easter, [27]; and forty days' Fast of n̄. ant, 90.
- Nicene Creed, its origin and Liturgical use, 170; used by Eastern Ch. at Baptism, 223; English, Greek, and Latin versions, 169, 170.
- Nicholl, Sir John, on use of Burial Service, 293.
- Nicholson, Bp., on Catechism, 243.
- Nicolas, St., [61].
- Nicomede, St., [49].
- Nixon, Bp., on Catechizing, 243.

- "Noble," its ancient signification, sense of it in the *Te Deum*, 13.
- Nocturnal Services, abolished, [28].
- Nocturns, meaning of, 314.
- Non-Communicating attendance, 157. 173. 179.
- Non-conforming ministers to vacate preferment, [8]; lecturers forbidden to preach, [9]; party in Church, lxxviii.
- Non-conformists could conscientiously use the Prayer Book but would not, xxxvii; Prayer for, 65.
- NORTH-SIDE of the Altar, that part of the front of the Holy Table, which is on the right hand of the Cross, and consequently on the left of the Celebrant.
- "North-side" rubric, 160. 165. 583.
- Northey, Sir E., his opinion on change of name in Confirmation, 258, n. 2.
- Notes "respecting the ministrations" in early Prayer Books, 120.
- Notice of Holy Communion, 171; to be given before Communicating, 163.
- Notker, author of *Media Vita* and *Dies Irae*, 297.
- Nowell, Alexander, reputed author of Catechism, 242.
- Nunc Dimittis, its early use, 35.
- Nuremberg Office, prayer from, 218.
- Oak, St. Augustine's, xviii.
- Oath of Supremacy, in Sealed Books, 549; ordered by 1 W. and M. c. 8, 549; ordered by 21 & 22 Vict. c. 48, 549.
- Oaths, when to be taken, by Clergy Subscription Act, 1865, 549.
- Obedience, oath of, to his Superior exacted from Bishop, 569; oath of, to Pope required from Bishop elect, by the Roman Pontificals, 569; profession of, by Bishop elect to Archbishop of Canterbury in Old Pontificals, 569.
- Obedience, vows of, in Baptism, 223.
- Obit Service at Windsor, 302.
- "Objections and Exceptions," raised against the Prayer Book at the Savoy, xxxix.
- Objections, their frivolous nature illustrated, [13].
- OBLATON, the act of offering the Body and Blood of Christ in the Holy Eucharist.
- "OBLATIONS," the Bread and Wine placed on the Altar preparatory to Consecration at the offertory or "lesser oblation."
- Oblation, of Elements, 149. 172; Prayer of, 191; Prayers of, in ancient Liturgies, 154; Prayer of, in Reformed Liturgies, 154; in Scottish Prayer Book, 583.
- Obscurements of the Litany, 51.
- Occasional Offices, hymns might be appropriately introduced in, lxxv.
- Occasional Prayers and Thanksgivings, 61.
- Occasional Thanksgivings, not fully authorized until 1661, 66.
- OCCURRENCE of Holydays, the coincidence of two or more on the same day.
- OCTAVE, the eighth day after a festival. The intervening days are said to be "of" or "within" its octave.
- October 23rd, Service for, in Irish Prayer Book, 585.
- Offerings at Churchings, 306.
- OFFERTORY, or lesser oblation, the offering up of the Bread and Wine, and of the Alms in the Holy Eucharist.
- Offertorium, a short Anthem (or offertory sentence) sung at oblation of elements, 173.
- Offertory, 172; sentences, classifications of, 174; money, application of, 199.
- Offices, daily Mediæval, their complex form, [63]; of the Eastern Church, [62], [63]; for anointing the Sick, A.D. 1549, 287; for the departed, Sarum Psalms, 321—323. 345, 346. 349. 370. 372, 373. 385. 401. 404. 482. 496, 497. 503. 510. 518. 520. 522—524; of the Primitive Church, of what they consisted, [62]; Mediæval, well adapted to Communities, [63]; consisted of seven separate Services, [63].
- Offrande, 198.
- Old Service Books, their directions minute and tedious, [21].
- Omission of an order not necessarily a revocation, 258.
- Omissions of Names in the English Calendar, [37].
- Onesiphorus prayed for after death, 301.
- "Open penance" not now possible or desirable, 309.
- "Open Prayer," meaning of, [4].
- Opposition to the Common Prayer, Reasons for, [12].
- Oratory, the first Christian one, how consecrated, liv.
- "Order of Common Prayer to be sung in Churches," lx.
- "Order of Communion," added to the Mass, 150; referred to, 177. 180. 195.
- "Order" for Daily Prayer, its simple meaning, 1; for the Visitation of the Sick, 277; of Prisoners, 586.
- Order of delivery of Elements, 190.
- Orders, derivation of the word, 540; Sacramental, 540; cannot be made void, 553; English, recognized by Pope Julius, 536.
- ORDINAL, the Offices for the Consecration of Bishops, and the Ordination of Priests and Deacons.
- Ordinal, English, Derivation of, 532; Revision of, 535; authorized and annexed by Act of Uniformity, 534; incorporated with the Prayer Book, xl; of 1549, 535; of 1552, 536; of 1662, 537; attempt for Revision, 1689, 538; absence of notes on, 532; introduction to, 530; preface to, 540; on Visitation of the Sick, 275.
- Ordinarium Missæ, 145. 148.
- ORDINARY, the Bishop of the Diocese or other person acting by his authority.
- Ordinary, definition of, 551. 559; and justices to determine offences and conviction, [5].
- Ordination, Canonical Impediments to, 542; Canonical Requisites for, 542. 559; Essentials of, 538; Words essential to, 539; Effect of, 539; Greek words for, 538; and Mission distinguished, 553; Power of, reserved to Bishops, 543; by Priests null and void, 543; Place of, 541; Times of, 544; Persons to be present at, 541; Testimony of People to precede, 541. 555.
- Origen catechized, 241; speaks of forty days' fast, 90.
- Oriflamme, the banner of St. Denys, [59].
- ORNAMENTS, all the several articles used in Divine Service, whether vestments of the ministers or furniture of the Church.
- Ornaments of Church and Ministers, lxx.
- "Ornaments," what they mean, distinction by the Judges, lxx; as in use in second year of King Edward to be retained, [6]; some omitted as inconsistent with our Prayer Book, lxxiii; Edwardian, what they were—four sources of information, lxxi; Comparative List, lxxii; of the Church, and ministers—specification of them desired by Bp. Cosin, lxxvi; intentionally legalized in the revision of 1662, lxxv; characteristic of military and other official classes, lxxvii; Essential and Supplemental, lxxvi.
- O Sapientia, [61]. [76].
- Osiander, a Foreign Reformer, xxvii.
- Osmund, St., his revision of English Liturgy, xviii. 17. 147. 149.
- OUR LADY, the old English designation of the Blessed Virgin, retained in our Table of Lessons.
- "Outward and visible Sign," 249.
- Overall, Bp., reputed author of latter part of Catechism, 242; his practice at Greater Oblation, 192; on Solitary Masses, 198.
- "Pædagogus" of St. Clement of Alexandria, 241.
- "Pain béni," 198.
- Palestrina, appointed by Council of Trent to reform Ch. Music, lix.
- PALL.—1. A covering for a bier. 2. A vestment woven of lambs' wool, formerly received from the Pope by Archbishops, and figured in the arms of the Abp. of Canterbury.
- Palls of Archbishops, how made, [39].
- Palmatus, case of, 223.
- Palm Sunday, why so called, 96.
- Palm bearing, 97; branches, Benediction of, 96.
- Palmer on Gallican Liturgy, 148; on Liturgy of St. Mark, 146; on the reading of Holy Scripture, [25]; on Private Celebration,

- 290; on position of Gloria in Excelsis, 194; on Vow of Obedience, 223.
- Pamelius, Liturgicon Ecclesiæ Latinæ, 70; on corrupt forms of Gloria in Excelsis, 194.
- Pamphlets against the Prayer Book in 1660, [12].
- Pantheon at Rome; its Christian dedication, 143.
- Parables, Christ speaking in them, 424.
- Parabolic Instruction, 423.
- Paraphrase of the Apostles' Creed, 20; of the Lord's Prayer by Keble, 32.
- Parents formerly forbidden to act as Sponsors, 216.
- Parish to provide Elements, 193; -Priests to frequently declare the vernacular form for Baptism, 231, Orig.
- Parishioners, what they are liable to provide, lxxiv; to provide true copies of the Book of Common Prayer under penalty, 10.
- Parish Registers, neglect of during the Rebellion, [14].
- Parker, Abp., Consecration of, 536; on wafer bread, 198; Q. Eliz., letter to, on Ritual, lxxvii; on interpretation of Canons, 243.
- Parkhurst, Bp., on wafer bread, 198.
- Parliament, Authorship of Prayer for, 64.
- Parliamentary debate on Settlement of Religion, in 1660, xxxvii.
- Parochial notices, 172.
- Pascha, Dominicæ Passionis, Resurrectionis; Annotinum, 104. 107.
- Pasque Eggs in North of England, 104.
- Passion of our Lord, how read in Salisbury Missal, 96.
- Passion Psalms, 319. 342. 408. 439.
- Passion Sunday, proposed change of Collect in 1688, 95; why so called, 95.
- PASTORAL STAFF, the crook used by Bishops, now generally borne by their chaplains. [See CROZIER.]
- PATEN, the plate on which the Element of Bread is placed for consecration and administration in the Holy Eucharist.
- Patient waiting, 371.
- Patras, martyrdom of St. Andrew, 129.
- Patriarchal age, its witness to the principle of ceremonial worship, xlvi. xlviii.
- Patristic writings, read occasionally as Lessons, [23].
- Paul, St., his Conversion now his only Festival, 131; meaning of his name, 407; and the Collect for Sexagesima, 89; Liturgy of, 147.
- Paul of Samosata, his Baptism held not valid, 212.
- Paul's, St., School, "Catechism with A B C" used at, 242.
- Paulinus, Bp. of Nola, private celebration for, 290.
- "Pax" after marriage, 274.
- Peace, Collects for, their introduction and connexion, 24. 38.
- Peace of God in the Church, 498.
- Peckham, Abp., his Const. on Catechizing, 241; his Const. on Communicants being Confirmed persons, 260.
- Pelagian heresy condemned by St. David, 43.
- Pell, Dr. John, reviser of chronological calendar, [27].
- PENANCE.—1. Repentance, as in Communion Service. 2. Penitential discipline, as in the 33rd Article.
- Penitential, Prefix, how appropriate to Daily Service, 1; Psalms, all used on Ash-Wednesday, 92; Ps. in Vis. of Sick, 277; Psalms, 322. 356. 367. 385. 457. 503. 516.
- Pentecost, its meaning and observance, Jewish and Christian, 112.
- People, The, reciting a Collect in Bapt. Offices, 221.
- Perambulations or Beating Bounds on Rogation Days, exhortation for, 110; Psalms for, 110.
- Perceval on the State Services, 573.
- Perpetua, St., [43].
- Perpetuus, Bp., of Tours, 73.
- Perry, Mr., on "Black Rubric," 199; on Reservation, 290.
- Persecutions, Literal and Prophetic, 429.
- Persons desiring Prayers of Church, Service for, 65.
- "Persuasion," its first introduction as indicating an opinion or sect, [13].
- "Perused," its technical sense, xxxi.
- Pestilence, private Communion in times of, 289. 292.
- Peter, St., claims of his successors at Rome, 138; customs of the Pope and people on his Festival, 137, 138; one of the oldest of the Christian Festivals, 137; united with St. Paul in the day of Commemoration, 137, 138; Liturgy of, 146.
- Peter and Paul, SS., alteration in the Collect by Bp. Cosin, 138.
- Peterborough, Anthem at, in Lent, 297.
- Petitions to restore use of Common Prayer, xxxvii.
- Philip, St., the Apostle, 134.
- Philip, the Deacon, 134; baptizing, 212. 222.
- Philippian gaoler, his Baptism, 211.
- Phillipotts, Bp., on Christ's continuous Sacrifice, 58.
- Physiological analogy respecting union with Head, 244.
- Pica type, [17].
- Pie, The, its complexity and difficulty, [16].
- Pirminius, Ancient Creed in, 17.
- PISCINA, a stone basin, with a drain to carry off water used in the ablutions of sacred vessels, &c.
- Pius IV. offers to confirm the Prayer Book, xxxv. 536.
- Plain Song, The Ancient, utilized at the Reformation, lix.
- Pliny, his mention of Christian Hymns, lv.
- Pollanus, his Glastonbury Prayer Book, 167. 196.
- Polycarp, St., quoted Gloria in Exc. at his Martyrdom, 194; on Visitation of the Sick, 275.
- "Pomp," meaning of, 222.
- Pontifical, varied for each diocese, 532; proposed, 1640, 536.
- Portiforia, or Fortuises, xx.
- Portraits of Christ, 377.
- Posidonius, Life of St. Augustine, 295, n. 2; on St. Augustine's Visitation of the Sick, 275.
- Position at Font of persons to be Baptized, 217, Orig.; of person making Baptismal renunciation, 222; of persons making Baptismal Confession of Faith, 223; of Priest and people at Font, 218; of Priest at the Altar, 159.
- Positions of child during trine immersion, 226, Orig.
- "Post Communio," meaning of, 68.
- POST-COMMUNION, the part of the Liturgy which comes after the Communion of the people.
- Post-Communion, 150.
- Poullain. See Pollanus.
- Pouring of Water in Baptism, 226.
- Poynet, Bp., reputed author of Catechism, 242.
- Præparat. Missæ, Psalm, Sarum, 348.
- Praise, a continuous Service, lii.
- Prayer Book, its general acceptance in 1549, xxx; its suppression A.D. 1645, xxxvi; great demand for, when prospect of Restoration, xxxvii; its authorization, xlii; its comprehensive directions, li; attempt to remodel it in the reign of William III., xliii; Baxter's, Dissenters', and Lord Burleigh, xxxix; of 1549, Holy Comm. at Burials in, 296; its Rubric for reservation, 289.
- Prayer, Common, public, open, distinguished, [2].
- Prayer for Church Militant, 174; its Title, 174; for a Sick Child or person in danger, 287; for Departed, from ancient Vesper Office, 301; of Humble Access, 185; of Consecration, 186; of Invocation in Confirmation Office, 257; of Commendation for one troubled in Conscience, 288.
- Prayers, of Oblation and Thanksgiving, 191; of the Church in New Testament, 69; after Versicles in Vis. of Sick, 278; commendatory at Ordination, 547; in Her Majesty's Navy daily, [20]; for the Sovereign and Family, 27; for the departed, 156. 175. 176. 301; not argued about but prayed, 297.
- Precautions in Administration of Baptism, 226.
- Precedence of Sovereign before Bishops, 53.
- Precentor, his part in Divine Service, li.
- PRECES, the petitions made by the Paſt at between the Lord's Prayer and the First Collect at Mattins and Evensong.
- Preces, Feriales translated, 21; Ambrosian, St. Fulda, Mozarabic, 46.
- Preface, to the Book of Common Prayer, [11]; of 1549, attributed to Crammer, [15]; of 1549 compared with that of Quignonez, [15]; of 1661, notes on, [11]; in Communion Office, 182.
- Prefaces, Proper, 184.
- Pre-sanctified Elements, 101.

- Presbyterians, their publications against Prayer Book in 1660, [12]; attempts to influence Charles II. against Prayer Book, xxxvii; their objection to Thanksgiving after Baptism, 228; their objection to proper position of Font, 217; their objections to answers of sponsors, 224; their objection to sanctifying of Water, 218; Form for "Communion, or Supper of the Lord," 206; Minister excused attendance on House of Commons, xl.
- Presence of Christ in H. Eucharist, 155; the cause of Christian Unity, 157.
- Presentation of Christ in the Temple, 131; an act of His humiliation, 132.
- Presentation of Candidates for Orders, Ancient form of, 547.
- PRIEST, a Church officer of the second order, whose distinctive "office and work" is, 1. To offer sacrifice to God. 2. To administer grace to men.
- Priest, Position of, at Altar, 159; after Marriage Service, 271; official dress of, 159. 588; "Priest alone," 4.
- Priests, Form and Manner of Ordering, 537. 554; summary of Service in Sacramentaries, Pontificals, and Ordinals, 533.
- Priesthood, Action of, in Ordination, 543; of the Laity, 22, 23.
- Primitive Church, Seasons for Baptism in, 215; catechizing in, 241; H. C. at burials in, 296.
- Principles of Ceremonial Worship in Early Church, xlvi; in Church of England, li.
- Prisca, St., [39].
- Private Baptism not to be without necessity, 231; provided for by ancient Rubrics, 231.
- Private Celebration, 289; Ritual requirements, 290; no novelty, 290; restrictions regarding, 290.
- Private Confession a recognized practice in Ch. of E., 283; when expedient, 284.
- Private recitation of Daily Offices by the Clergy, [19].
- "Pro-Anaphora," 148.
- Procession of the Holy Ghost, 170.
- Procession in Marriage Service, 271.
- Processional, English, of Cramer, xxii.
- Proclamations of Queens Mary and Elizabeth, xxxiii.
- Procter, on proposed revision of 1689, xliii.
- Profession of faith required at Baptism, 222; at Visitation of Sick, 281.
- Prohibited times for Marriage, [28]. 263.
- "Promise and vow" in Baptism, 245.
- Promptorium Parvulorum, on word "buximnesse," 267, n. 6.
- Pronouns, Change of, in Versicles, &c., 6; in Psalms, 324. 347.
- Proper Lessons for Sundays—principle of the Cycle, [26].
- Proper Psalms, Table of, [26].
- Prophecy, connecting the Old and New Dispensation, 16.
- Protestants, lapsed, Service for, in Irish Prayer Book, 586.
- Prothesis, Chapel and Office of, 173.
- Protocletos, a designation of St. Andrew, 129.
- Prymer, The King's, xxv.
- Prymers in English and Latin, xxiv; old English, translation and contents, xix.
- Psalms, The, by whom composed, 313; always intended to be sung, lx; our Lord's application of them, 316; their earliest Liturgical use, 313; Apostolic application of them, 316; manner of using in Divine Service, 313; three modes of saying or singing, 315; their weekly recitation, 314; their monthly recitation, its value, 315; Bible version of, 315; natural division of many into three portions, 331; Proper, principle of their selection, 24. 317; their purpose, 313; their many-sided application, 316; verses of, numbered, 316; to be said in private by Bishop Elect at Consecration, 570; their use as Introits, 68; of degrees, 496—506; in Bur. Office, 295; in Marr. Service, 270; in Vis. of Sick, 286; in Churching of Women, 305.
- Psalms, First Book, what they point to, 373.
- Psalms, Second Book, 373; their characteristic, 412.
- Psalms, Third Book, 416.
- Psalms, Fourth Book, 445.
- Psalms, Fifth Book, 470.
- Psalter, Introduction to, 313; its divisions, 313; ancient systems of, 314; pre-reformation use in English Church, 314; English, its gradual growth, 313. 315; English, what it represents, 316; English, order in which to be read, [23].
- Psalms, "Ecclesius Sarum et Eboracensis," 314.
- Public Baptism to be in the Church, 215; Confession and Absolution no novelty, 181.
- Pullain, his "L'Ordre de Prières Ecclésiastiques," 2.
- PULPIT, a raised structure of wood or stone generally used for preaching from.
- "Pulpit," how to be understood in Communion Service, 307.
- Punishment for offences against the Act of Uniformity, [+], [5].
- "Pupilla oculi," on Baptism of Christ, 209, n. 1; on Lay Baptism, 212.
- "Pure Offering" of Malachi, 152.
- Pure Water the matter in Baptism, 211.
- Purification of B. V. Mary, 131, 132; proper time of observing it—why, 132; its Title, Epistle, and Collect altered, 131.
- PURIFICATOR, a linen cloth used for wiping the Chalice after the Ablutions.
- Puritan leaven, its fermenting power, lxviii.
- Puritans, their antagonistic use of the Press, xxxv; their superstitious antipathy to the sign of the Cross, 227; their memorial against Lay Baptism, 212, n. 1; their objection to the Magnificat, 33, 34; their objection to public Confession by people, 181; their objection to Pr. of Invoc. in Confirmation, 257; their objection to Marriage Rubrics, 263; their obj. to word "worship," 269; their objection to word "depart," 267, n. 2; their obj. to Burial Service, 296; their wish to substitute transl. of 1611 for Commandments, 247; their wish to secularize Marriage, 274; their wishes with regard to Catechism, 243; their practice of sermons at funerals, 296; their scandal at the public irreverence, 3.
- Puritanism developed by foreign influence, xxx.
- Pusey, Dr., his letter to the Bishop of Oxford quoted, 50; his "Scriptural Views of Baptism" referred to, 213. 218, n. 2.
- Quadragesima, Sancti Martini, 73; Sunday, 88, 89.
- Queen Elizabeth, her Thanksgiving Prayer, 66.
- Queen's Mandate, History of, 568.
- Quignonez' Reformed Breviary, its influence, xx, [15]; manner of using Apostles' Creed, 17.
- Quinquagesima Sunday, 89.
- Quintin, St., companion of SS. Lucian and Denys, [39].
- Quintianus, his Rogation at Auvergne, 46.
- "Quires and places where they sing," 25.
- "Ratify and confirm," 255, 256.
- "Read," "Say," "Sing," Old technical language, lx.
- "Reading-desk," when invented, [64].
- READING-FEW, the Chancel stall occupied by the Officiant at Mattins and Evensong, 307.
- Real Presence, not denied in Black Rubric, 199.
- Reasons which influenced the Revisers of 1661, [11].
- "Reception into the Church," by the very act of Baptism, 227.
- Recitation of the Daily Service by the Clergy, [19].
- Reconciliation of Churches Service in Irish Prayer Book, 586.
- Recusants, The first, xxxv.
- Reformation, its Catholicity injured by Foreign influence, xxx.
- Reformed Liturgy of Church of England, 150.
- Refreshment Sunday, 94.
- Regeneration in Baptism, 213; most distinctly held by Ch. of E., 229.
- Regina v. Benson, case of, 262.
- Relics of SS. Lambert, [53]; Martin, [51]; The Holy Cross, [47]. [53].
- Remigius or Remi, St., [57].
- Remiremont, Bapt. Office of, 220.
- Renunciation in Baptism, Ancient English and other forms, 222, and n. 2.
- "Renunciation of the Devil," &c., 245; vow of, in Baptism, 222.

- Reordination sacrilegious and heretical, 540.
 Repeal of Acts respecting Divine Service, [6].
 Re-presentation in Eucharist, 155.
 Reproaches on Good Friday, 101.
RESEDOS, the ornamental structure that is placed above and behind the Altar.
 Reservation of Eucharist, 198; in time of Queen Elizabeth, 290; for the Sick in 1549, 289; recent instances of, 290; in Scottish Church, 290; by Nonjurors, 290.
 Reserve in personal application of Psalms, 439, 440.
 Reserve on subject of Holy Eucharist, 146, n. 2.
 Responds to the Lesson, [23]; Examples of, [16].
RESPONSES, the answers made by the choir and people after the Versicles or Preces, in the Litany, after the Commandments, &c.
 Responses after Commandments, 167.
 Responsive worship, on what the system is founded, 23.
 Restoration of Charles II. Service, 578.
 Restoration of Church Services in 1660, immediate, xxxvii.
 Resurrection, the, A Psalm of, 402.
RETABLE, a shelf or ledge behind the Altar, properly a part of the *resedos*, and often incorrectly called the *super-altar*. [See **SUPER-ALTAR**.]
 Reverence done to Gospel in Eucharistic Service, 169.
 Revised Prayer Book made unlawful by Q. Mary, xxxiii.
 Revision of Prayer Book in Elizabeth's reign, xxxiii; accepted by Parliament without discussion, xxxiv; well received by Romanists, xxxiv; in the reign of James after Hampton-Court Conference, xxxvi; of 1661, xl. 537.
 Reynolds, Bp., composed or compiled General Thanksgiving, 66; complained of shortness of Catechism, 242.
 Richard, St., [45].
 "Right hand," meaning of position in Marriage rubric, 263.
 Right hands joined in Marriage, 270.
 Ring, benediction of, 269, Orig.; delivery of, 268; of Edward the Confessor, [57].
 Riper years, Baptism in, 236.
 "Riper Years," limits of, 238. 240.
 Ritual Introduction, xlv.
 Ritualism, elaborate in heaven, xlix; Patriarchal, xlv; Mosaic, really Divine, xlvii; revelation to Bezaleel and Aholiab, xlvii; revelation to King David, xlvii; the old, transfigured by our Lord, liv; of the Apostolic age, lxviii; its revival—what should influence and regulate it, lxxx; usages of English Liturgy, 158; of Adult Baptism, 240.
 Ritus Baptizandi, 210; actual, 222.
ROCHET, the linen garment ordinarily worn by Bishops, 568.
 "Rock of Ages," mystical sense of, 351.
ROGATION DAYS, the Monday, Tuesday, and Wednesday before Ascension Day, set apart for special prayer and fasting.
 Rogation, meaning of, 109; Sunday and Week—their institution, 110; Fasts, Sevenfold Litany on, 47; Week, Collects for, by Bishop Cosin, 110; Epistles and Gospels for, 110; Services and Homily for, 110; observed yearly in the English Church before Ascension-tide, 46; Litanies decreed by various Councils, 46.
 Roman Catholics, burial of, 293; Attempt to reconcile extreme, xxxiv.
 Rome, Liturgy of, 146; never used by Church of England, 147, n. 2; "When at, do as the Romans do," saying of St. Ambrose, [45].
ROOD-SCREEN, the partition which divides the chancel from the nave. It ought always to be surmounted by the Holy Rood or Cross. [See xlix.]
 Routh, Dr., on Gloria Patri, 7.
 Royal Exchange, Legend on, 316.
 Royal Family; when first prayed for, 27.
 Royal Maundy, Office for, 99.
 Royal Proclamations, under Act of Uniformity, 27.
 Rubric, The First, necessity for it, lxxv; its prominent position, lxxv; why retained, lxxiv; on seasons for Baptism from 1549 to 1661, 216; of 1548 on Catechizing, 242; of present P. B. on Catechizing, 243.
 Rubrics, to what they point, li; their reform by the Convocation Committee, xxi; Four early reformed ones compared, lxvi; after the three Collects—their importance, 25; introductory to Liturgy, 163; after Communion Office, 197; on seasons for Marriage, 263.
 Rubrical directions for reading, saying, singing—what they mean, lx.
 Rufinus on a case of Lay Baptism, 212; his Comment on the Apostles' Creed, 17.
 Rule as to Accessories, authoritative, lxxv.
 Rule for Priests and Deacons saying Daily Service, [19].
 "Rule of Truth," what it was, 18.
 Russian or Eastern Liturgy of present day, 146.
 Sabellius, his heresy, 42.
 "Sacerdos," used in an inclusive sense, 224, n. 1.
 Sacerdotal power derived from the Holy Ghost, 563.
SACRAMENT, an outward visible sign of an inward spiritual grace, and a means whereby we receive that grace. [See the Catechism, 249.]
 Sacramentaries of 5th and 6th centuries, rather compiled than composed, 68; ancient, their Collects, [63]; of SS. Leo, Gelasius, and Gregory, proper prefaces in, 185; of Gelasius and St. Gregory on Confirmation, 251. 257; on Benediction of Water, 224.
 Sacramentary of Gelasius, Third Collect at Evensong, 39; of St. Gregory, what it represents, xviii; on Baptism, 209. 211.
 Sacraments, number of, 249.
 "Sacramentum," or military oath, 157.
 Sacrifice of Christ continuous, 58. 188.*
 Sacrifice, Eucharistic, 152. 188. 385.
 Sacrificial terms early applied to H. Eucharist, 153.
 Saints commemorated by Ch. of England, [37]; Eastern, Modern Roman, Salisbury Use, comparative view of, [38—60]; French, in Eng. Cal., [37].
 Saints' Days, origin of their observance, 79. 295.
 Salem, its typical sense, 421.
 Salisbury Breviary, Prayers for King and Queen, 27.
 Salisbury Manual, its Rubrics on Baptism, 212; on seasons for Baptism, 216.
 Salisbury Missal, 149. 200; preference given to it, lxxii; Rubric for First Sunday after Trinity, 116.
 Salisbury Rubric on Font or substitute, 217; as to position of persons to be baptized, 216, Orig.
 Salisbury Use, Ad faciend. Catech., 219, Orig.; in Vis. of Sick, 277, &c., Orig.
 Salisbury and York Vernacular Exhortation to Sponsors, 229, Orig.
 Saliva used in Baptism, 210.
 Salt used in Baptism, 210.
 Salutation in Vis. of Sick, 277.
 Salvation of unbaptized infants, 230.
 Samaritans; Confirmation of, 251.
 Sancroft, Secretary to Committee of 1661, xli; Supervisor of the Press in 1662, xlii.
 Sanctus in Communion Office, 183.
 Sand substituted for water in Baptism, 211.
 Sanderson, Bp., his mode of public service, during the 15 years persecution, xxxvi; his Preface to P. B., [11]. 236.
 Sarum Exhortations to Sick, 280.
 Sarum Liturgy, Analysis of, 200. 149.
 Sarum Manual on Spiritual Communion, 231.
 Sarum Rite, Dirge of, 294, &c.
 Sarum Rubric on Interrogatories in Baptism, 224; after Marriage, 263.
 "Sarum Use," or Prayer Book, what it was, xviii; Remodelled by St. Osmund, xix; in Matrimony, 261, &c., Orig.
 Satan's misquotation of Scripture, 446.
 Saturnalia, offered difficulties to Church, 82.
 Savoy Conference, what authorized by letters patent, xxxviii;

- how it ended, xli; exceptions of Presbyterians, 4; specimen of their frivolous character, 13, n.; leader of the Opposition, [12].
- Saxon Homilies, A.D. 700, 31.
- "Saying" explained, 2.
- Scambler, Bp., his lawless proceedings, xxxv. [64].
- Schoolmasters required to subscribe to the Act of Unif., [8].
- Scottish Prayer Book, Mr. Bright's History of, 580; not sanctioned by the General Assembly, xlv; its influence on English Book, 584; errors of law, &c. in publishing it, 582; vigorously and successfully opposed, xlv.
- Scottish Liturgy *in extenso*, 205; referred to, 151. 167. 175. 185. 186. 190. 192. 197. 199.
- Seager's, Mr., Edition of *Portiforium Sarisb.*, xix.
- "Seal" or "Sealing," terms applied to Confirmation, 251.
- Sealed Books, 405; what they were, lxiii; engraving of one, *front*.
- Seasons most proper for Baptism, 215.
- Second Prayer Book of Edward VI., xxxi.
- SEDILLA, seats near the Altar, to be used by the ministers during the sermon at Holy Communion.
- Sennacherib a type of Antichrist, 421.
- Sentences, Exhortation, &c., when prefixed, 1; used as Invitations, 1, 2; "Read with a loud voice" implies intonation, 2.
- Septuaginta, &c., names and reckonings, 88; Epistles and Gospels, 89.
- SERMON, an oral instruction or exhortation, delivered by the preacher at Holy Communion, and at other times, 172.
- Sermon after Marriage, 273.
- Sermons and Lectures to be in English, by injunction of Edward VI., xxvi; at funerals, 296.
- SERVICE, the Canticles and other parts of Mattins, Evensong, or the Liturgy, set to music, more elaborate than Chant or Plainsong.
- "Service of Song," sanctioned by our Lord, lv; its threefold division, lv, n.
- Seven Hours of Prayer, Aggregation and Condensation of, [63].
- Shakespeare [Henry VIII. iii. 2], 222; [King Lear, IV. vi.], 297.
- Sharpe, Abp., on prohibited seasons for Marriage in 1750, 263.
- Shell used for Baptismal affusion, 226.
- Shepherd, The, of Israel, 430.
- Shortening the Services, 5. 25. 40. 65.
- Shrine, Ven. Bede's, Anecdote of, [49].
- Shrove Tuesday, 89.
- Sick, The, a daily prayer for, 65; *Visita. of*, 275, &c.; Communion of, 289.
- Sidonius Apollinaris, Gallic processions, 46.
- Sign of the Cross, its abuse and disuse, [21]; sign of the Son of Man, 320.
- Signing with the Cross, 226; Canon on, 227; of the water in the Font, 218; in Confirmation, 258.
- Silvester, St., [61].
- Simon Magus, 92. ^a
- Simon Zelotes, St., 142.
- "Simplicity" no characteristic of primitive worship, 148.
- Singing, God's Church a singing Church, liii; during Communion of people, 190.
- "Singing cakes," a term applied to wafer bread, 198.
- Sins, Seven deadly, 245.
- Sion transfigured into the New Jerusalem, 439.
- "Si Quis," 542.
- Slander of the Church and Sacraments, 475.
- Smith, Sir Thomas, secretary to Queen Elizabeth, xxxiii.
- "So to eat," explanatory of phrase, 186.
- S. P. C. K.'s translations of the Prayer Book, xlv.
- Socrates on Antiphonal singing at Antioch, lvi; on *Missa Sicca*, 197.
- Solemn League and Covenant, Declaration against, 8.
- Solemnization of Matrimony, 261.
- Solitary Masses, 197.
- Solomon, a philosopher and yet a ritualist, xlviii.
- "Son of David," Note on, 586.
- "Song, Service of," lxi.
- Southchardefirth [South Charford, now annexed to Breamore and Hale, Hants] parish Manual, 229.
- Sovereign, The, always prayed for in the English Church, 26.
- Spain, King of, allowed to nominate Bishops and Abbots, 569.
- Sparrow, Bishop, Collection and Rationale of, 12; on time for Churching, 306; on Catechizing, 249.
- Special Prayers in *Vis. of Sick*, 287.
- "Spices, the principal," 378.
- Spiritual Communion, 291.
- "Sponsalia," 261.
- SPONSORS, persons who answer in the name of children who are brought to be baptized; "Godfathers and Godmothers."
- Sponsors simply the mouth-pieces of the child, 224; their responsibility in abeyance while parents live, 229; to wait at church door in P. B. of 1549, 217.
- Sprinkling in Baptism, 211; unauthorized and unsafe, 212. 226.
- Standard adopted as to accessories of Divine Worship, lxvi.
- Standing, posture for the Priest when speaking authoritatively, 4; posture, intention of the Reformers, 23; at the Gospel, 169; of Celebrant in receiving, 189.
- "Standing up," old Rubric, 22.
- Star of Bethlehem, what supposed to be, 84.
- "State of salvation," what, 246.
- "State Services," [39]. 578.
- Statute of Six Articles, its influence on Prayer Book, xx; its repeal, xxi.
- Statute 25 Hen. VIII. on Marriage Licences, 261; 4 Geo. IV. against Clandestine Marriages, 262; 26 Geo. II. on publication of Banns, 262.
- Stephen, St., 78.
- Steps into primitive fonts, Seven, 211.
- STOLE, a long strip of rich silk worn over both shoulders by Priests and Bishops, but over the left shoulder only by deacons.
- Structure of Primitive Liturgies, 148.
- Styrie, his description of Lent Services in Chapel Royal, lxiii.
- Styrie's Cranmer, [2]. [28]. 216, n. 1.
- Style, Change of, 73.
- Sub-deacon, his duties at the Altar, 160.
- "Sudden death," Objections and Answers, 51.
- Suffrages or Preces, 21.
- Suffrages of the Western Church allied to Great Collect of Eastern, 21.
- Suffrages in Bur. Office of 1549, 299.
- Suicides, Burial of, 293.
- Sumatra, martyrdom of St. Thomas, 130.
- Sundays after Epiphany, how reckoned, 88; and other holydays for Public Baptism, 215; in Lent, not Fast-days, 92.
- Συνεδοκεῖτε, explains old English "alloweth," 220.
- SUPER-ALTAR, a small portable slab of costly material formerly used at certain times to consecrate upon being laid upon the MENSEA. [See MENSEA, RETABLE.]
- SUPER-FRONTAL, the covering of the MENSEA, hanging over the frontal for about six or eight inches. [See FRONTAL.]
- Supremacy restored to the Crown by Act 1 of Elizabeth, xxxiii.
- Sursum Corda, 182.
- Survey of Church goods in 1562, lxxii.
- "Swine's flesh," singular reading of ancient Vulgate, 335.
- Swithun, St., [51].
- Symbolic usages, Divine authority for, lxv; may be combined with highest spiritual worship, lxv.
- Symbolism of linen cloths, 164; of Wedding-ring, 268; of Psalm lxxviii., 425.
- Symbols of the Name of Jesus, [53].
- "Symbolum Athanasii," always sung as a Psalm, 41.
- Symmachus, Bp. of Rome, placed Gloria in Excelsis in Liturgy, 194.
- Sympathy between animate and inanimate works of God, 522.
- Synodals explained, [16].

- Tabernacle of the Flesh, 332, 340.
- Table of the Condensation of the Services, xxix; of Contents, freely handled by modern printers—authorized form—successive changes, [2], [3]; of comparative colours of Vestments, lxxix; to find Easter, Quarto-deciman controversy, [29], [30]; of Proper Psalms, additions proposed, [26]; of Proper Lessons, 1559, 1661, [25]; of Apostolic statements corresponding with the Creed, 19; of Authorship and Compilation of the Psalter, 313; of Pre-reformation weekly use of Psalter, 314; of Scripture accounts of Institution of Holy Eucharist, 153; showing origin of various Liturgies, 147; comparing features of Primitive Liturgies, 148; of Burial Lectons, 295; illustrating Title of Prayer Book, [2], [3]; of Ornaments, comparative List, lxxii—lxxiv.
- Table-cloth on the Altar, an innovation, 164.
- Tables and Rules for the Feasts and Fasts, [27].
- Tables of Moveable Feasts for the 19th Century, [31], [32].
- Tabular View of variations in the Litany, 53.
- Tallis, his plain Song for the Reformed Litany, lx.
- Taper in Baptism, its symbolism, 222.
- Taylor, Bp. Jeremy, Statement regarding Cranmer, xxx; his prayer for benediction of water, 226; on Marriage, 268, 274.
- "Te Deum," 183; its Music, Ambrosian, lxi. 12; its supposed Authorship, 10; its Rubric, 15; special notice of 9th, 16th, 21st verses, 13; separate use of as a special Thanksgiving, 12; proposed Substitutes for Lent and Advent, 11, n.
- Telesphorus, Bp. of Rome, reputed author of "Gloria in Excelsis," 194.
- Temple, dedication of, 353; its glory merged in the Church, 418; Manifestations of the glory of the Lord therein, 84; Music and Singing, liii; Music, not extant, lv.
- Temporary Insanity, Verdict of, 294.
- Temptation of our Lord, its representative Character, 92.
- Ten Commandments, Compendium of, 246, and n. 1.
- Tenebræ, ancient Office in Holy Week, 98.
- Tersanctus in Communion Office, 183.
- Tersanctus in 99th Psalm, 455.
- Tertullian on Amen after Prayer of Consecration, 189; on Baptism, 209, 210; on trine immersion, 211; on renunciation in Baptism, 222; on Confession of Faith in Baptism, 223; on Benediction of Waters, 224; on Lay Baptism, 212; on Confirmation, 251; on Marriage, 261; on Wedding-ring, 268; on Burial, 295, n. 2; on Prayer for Dead, 301; on postures in Prayer, 189; on Early Christian Worship, [62]; on the Jews of Egypt, 315; on Fasting, 90; on meaning of the Psalms, 316.
- Thaddeus, St., Liturgy of, 146, n. 4.
- Thanksgiving after Baptism, 228; after Communion, 193; for Peace, its Authorship and Modification, 67.
- Tharsis and the Isles, 415.
- "Then," after the first Rubric, its force and meaning, 25.
- Theodore, Abp., Penitential of, on the *Viaticum*, 289.
- Theodoret on rejection of the Jews, 396.
- Theophania, Name anciently in use for Epiphany, 70, 77, 83, 84.
- Third hour for Celebration of H. C., 161.
- Thirtieth of January Service, 578.
- Thirty-nine Articles, assent of the Clergy required to them, Act Unif., 9.
- Thomas, St., the Apostle, 130; Christians of, still a witness to his labours in India, 130; St. Thomas's Day, Collect for, referred to, 245.
- Thomas, St., of Canterbury, his Festival, [37]; said to have instituted the Trinity Feast, 114.
- Thorndike on Prayer of Oblation, 192; on looking eastward, 19.
- Three estates of the Realm, xxxiii; Orders of Ministers held by Church of England, 566.
- Thrupp on the Psalms, 313, 426; on 139th Psalm, 512.
- Thursday in Holy Week, its special observances, 99.
- Time for Mattins and Evensong, [20].
- Times and seasons, their appointment and division, 24; how the Church has always intended to reckon them, 73.
- Tindal, Lord Chief Justice, on Marriage by Deacons, 264.
- TRIPLET, a hood of some black material which is not to be silk, worn by Ministers who are not graduates. [Can. 58.]
- "Title" of Prayer Book "Common Prayer," [2]; "other rites and ceremonies," what they mean, [2]; of P. B. "together with the Psalter," [2].
- Titles of our Lord, as used in the Advent Antiphons, 76.
- Toleration, Charles II.'s declaration of his intentions, xxxviii.
- Touching for the Evil, 580.
- Tower of London and Courts of Westminster, Sealed books for, 10.
- Traditional words of Christ on the Cross, 354.
- Traditions, what they imply, xlviii; respecting the Apostles' Creed, 16, 369—410.
- TRANSEPT.—1. The transverse portion of cruciform Churches.
2. The northern or southern end of this.
- Transfiguration of our Lord, [53], 84.
- Translation of King Edward, [49].
- Translations of the Common Prayer, xlv.
- "Transubstantiation" protested against in Black Rubric, 199.
- Tree of Life a type of Holy Eucharist, 151, 448.
- Trent, Council of, on Water in Baptism, 211; on age for Confirmation, 253; Catechism on Baptismal Affusion, 226, n. 1.
- Trine Affusion, 226; Immersion, 211, 226, Orig.
- Trinity, Holy, great significance of the Festival, 114; the Psalm of Praise to, 401; Sunday, 114; Sunday, Sarum Psalms, 339, 346, 380, 414, 452—454.
- Trinity Coll. Cambridge, Commemoration Service at, 302.
- Trisagion, 183.
- "Troth," meaning of, 267, n. 3.
- Truths of Heathen Philosophy, Church's application of some, 89.
- Tuesday in Holy Week, last day of our Lord's public Ministration, 97.
- TUNICLE, the outer vestment of the Epistoler at the Holy Eucharist: in the Rubric the term is applied also to the DALMATIC, which is almost identical with it in character.
- Twelfth day after Christmas, a memorial of our Lord's Baptism, 83.
- Twenty-ninth of May Service, 578.
- "Two Tables" of Law, 247.
- Types of Eucharist—their number, agreements, and diversities, 146; of our Lord in suffering, 408; of Intermediate State, 473.
- Typical character of David, 320, 324; persecutions, 320.
- Unbaptized infants dying, 230; burial of, 293.
- Unconsecrated Elements for use of Curate, 198.
- UNCTION, the anointing with holy oil at Coronations, and other rites of the Church. [See ANOINTING.]
- Uction in Confirmation, 251, 258; extreme, 275; of the Sick in reformed P. B., 275, 287, n. 1; a term applied to Confirmation, 251.
- "Ungodly," principal and instruments, 318.
- Uniformity, Act of, Edward's, xxxi, xxxii; repealed by Mary, xxxiii; Primo Elizabethæ, [4]; 14 Carol. II., [6]; Binding on the Clergy, [4]; documents respecting, lxxiv, lxxv.
- Uniformity of Services, xix.
- Union Jack, Crosses in, [45].
- Union with Christ in Baptism, 214.
- "United Ch. of England and Ireland" a misnomer, [2].
- Unity of the Church, 498.
- Unity of mind of the whole Catholic Church, 132, 133.
- Unity underlying divisions of Christendom, 158.
- Unmarried mothers to do Penance before being Churched, 304.
- Unworthy Communion, Great care of Eng. Ch. as to, 179.
- "Upper Room, The," liv.
- "Usages" of the Scottish Liturgy, 584.
- "Use" of the Church of England, [2]; of Holy Communion, 155; of Visitation Office, 275.

- "Uses" in England diverse previous to Reformation, xviii. [18].
147. 149; now to be one and the same, [18].
Uses of Salisbury, York, and Hereford, in Espousals, 267.
- Vaison, Council of, its Canon on the Gloria Patri, 7.
Valentine, St., [41].
Vatican, martyrdom of St. Peter, 139.
Vaughan's "Lessons of Life and Godliness" quoted, 55.
Veil, 191; formerly insisted on in Churching of women, 304; of Temple, its rending, 337; of Chancel, in Primitive Church, xlix.
Venantius Fortunatus, his Commentary on Athanasian Creed, 41.
Venerable Bede, his death in connexion with Ascension Collect, 112.
Veni Creator sung at Mass, 149. 200; Authorship of, 560; Translation of, ascribed to Dryden, 575.
Veni Creator Spiritus, use of, at Consecration of Bishops, 575.
Venite Exultemus, its use in the Temple Service and early Christian, 8; Invitatory to, 7; old custom of reverence, 9.
Veredemus, Companion of St. Giles, [55].
VERGER, a lay officer, who carries a staff before dignitaries in processions, attends to the placing of the congregation, &c.
Verity, Christian, explanation of term, 48.
Vernacular, its use always encouraged in the Church of England, xxiii; ancient form of Baptism in Sarum Use, 231, Orig.; ancient forms of Lord's Prayer, 30; ancient forms of "Apostles' Creed, 36; ancient forms of *V.* and *R.* for Peace, 21; ancient forms of Collects, 38. 64. 113. 115. 133. 141; ancient forms of Nicene Creed, 170; Confession at Holy Communion, 180; Exhortation to Holy Communion, 178; Gloria in Excelsis, 195, n.; Exhortation at Baptism, 229; in Marriage Service, 265—268; in Visitation of Sick, 281, 282. 292; Litany referred to, xxii. 48; Te Deum referred to, 13; Athanasian Creed referred to, 41; ancient origin of parts of Litany, 54. 56; ancient expositions referred to, xxiii.
Vernacular of our Lord and His Apostles, 315.
Versicles, explanation of term, [16]; from the ancient form translated, 21; before Collects, old Rubric on, 22; in Confirmation Office, 257; in Vis. of Sick, 278.
Versions, Ancient, of the Psalter, 315.
Verulam, [49].
Vessel for bringing water to Font, 217.
VESTMENT, the Chasuble; the term sometimes includes *all* the Eucharistic vestments, or may be applied to any one of them.
"Vestment," term applied to Chasuble as *the* Eucharistic robe of Christendom, 159.
Vestments, Eucharistic, 159, 160. 587; their colours, lxxviii; their material, lxxvii; their form and symbolism, 587; illustrations of, 588; to be used in Visitation of the Sick, 276.
"Viaticum," Communion of the Dying, 289.
Vicarious penitence of Christ, 386. 457. 503.
Victricius, reputed author of the Athanasian Creed, 41.
Vienne, City of, origination of Rogation Fast, 46.
VIGIL, the fasted Eve of a festival.
Vigil of Christmas, how observed in ancient Church of England, 77.
Vigil of Easter, ancient mode of its celebration, 103.
Vigils, Fasts, and Days of Abstinence, Table of, [28]; not observed in the Paschal Quinquagesima, 111; no longer an Evening Service, [28]; Collects used on, 72.
Vincent, St., [39].
Vine, The, illustrations of its mystical meaning, 431.
Visitation of B. V. Mary, [51]; of Dioceses on accession of Edward VI., xxv.
VISITATION OF THE SICK, an Office to be used with sick persons, with or without Communion or Anointing.
Visitation of the Sick enjoined by H. Scripture, Fathers, and Councils, 275. 412; a formal rite, 276; Introduction to, 275.
Visitation of Prisoners Service in Irish Prayer Book, 586.
Vocation to the Ministry extraordinary and ordinary, 539.
Voice, of the Church, 321; of the Lord sevenfold, 352.
VOLUNTARY, a piece of music played after the Psalms, and before and after service; sometimes during the Communion of the People.
Voluntary, after the Psalms, 9; substituted for the Agnus Dei at Durham, 9; at the conclusion of the Service, 25.
Vows, Baptismal, 222, 223.
Vulgar tongue, its gradual adoption in the Services, xxii.
Vulgate, The ancient, of St. Jerome, 315.
- WAFER, or WAFER BREAD, a small unleavened cake used for the Eucharistic Bread. The Rubric permits the substitution of fine wheaten bread of the ordinary kind, 198, 199. 498.
Walchius' Bibliotheca Symbolica for earliest forms of the Creed, 36; on Protestant Catechisms, 242.
Waldenses, regarded water as unnecessary in Baptism, 211.
Wales, Funeral Offertory in, 296.
Warburton, his discontinuance of use of cope, 159.
Washing of disciples' feet connected with Institution of H. Eucharist, 157; a sacramental act, as well as symbolical, 98.
Water, Benediction of, 224; "the outward visible sign or form in Baptism," 211; sanctifying of, 218.
Waters of the Neva blessed, 218, n. 2.
Waterland, his history of the Athanasian Creed, 41.
Wedderburn, Bp. of Dumblane, and the Scottish Prayer Book, 581.
Wedding breakfast, why after the marriage, 262.
Wedding ring, 268.
Wednesday in Holy Week, ancient Office for, 98.
Welsh Prayer Book, xlv. [10].
Westminster Abbey, Wafer bread used at, 498.
Westminster, Monks of, privileged in respect of age for Ordination, 541; Synod of, on Comm. of Sick, 289; Synod of, marriage enactment, 261.
Whitgift, Abp., memorialized by Puritans against Lay Baptism, 212, n. 1.
Whitsun, the English name of Pentecost, its origin, 112; Ember Days, of primitive observance, 114.
Whitsun Eve, Day, and Season, Sarum Psalms, 380. 404. 461.
Whitsunday, Collect for, how formerly used, 113; 1549, the English Prayer Book first used on, 113.
Whitsuntide Psalms, 380. 461. 518.
"Wilkins' Concilia," on use of Salisbury Missal, lxxii; referred to, 230, marg.
Will of God, law over all, 246; modes of its expression, 246.
William III., and the Lesson about Judas, 578.
William of Malmesbury on Altars of wood, 158.
Wilson, Bp., on Invocation of Holy Ghost, 187.
Wimbish, Register at, on prohibited seasons for Marriage, 263.
Windsor, Obiit Service at, 302; Obiit Sunday, Psalms for, 341. 520.
Wine used as Matter in Baptism, 211.
Winepress, its typical and prophetic meaning, 432.
"With," its Liturgical sense, 3.
Wolsey, Cardinal, his efforts to bring about a Reformation, xix.
Woman, her dependence on man, 267.
Women not to baptize save in extreme necessity, 231, Orig.
Wood (Ath. Oxon.), on Office for Adult Baptism, 237.
WORD, The, Personal, in all the Psalms of the First Book, 373; in 119th Psalm, 486; before the Sanhedrim, 433.
Words of Institution, 187; of Prayer consecrated by our Lord, 356, 357.
Worship of Heaven, as seen by St. John, xlix; Patriarchal, xlvi; Mosajo or Jewish, so called, but really Divine, xlvi; Spiritual, see Communion with God, xlvi; its principal parts, 2; offered to a person present to receive it, 1; Christian, supplemented

- not supplanted that of the ancient Church, liv; Ceremonial and Musical, our Lord's practice, liii; of the Church of England, application of the Ritual principle, l, li; Daily, transferred from the Cloister to the Parish Church, xx.
- "Worship," meaning of, in Marriage Service, 269.
- Wren, Bp., his order respecting Marriages, 263; his Injunctions on Churching, 305, 306; his Injunctions on Public Prayer for Sick, 288; his directions to Ministers, 136.
- Wyche, Sir Cecil, his discovery of an error in MS. of Prayer Book, xlii.
- Year, The Church's, beginning from Advent and Christmas, 73.
- York Manual, directions as to who are not to communicate, 291; vernac. Exhort. to Sponsors, 229.
- York Minster Library, Fothergil's MSS. in, 253.
- York, Use of, circ. A.D. 700, in Confirmation, 252. 257.
- York Use (Marriage), 264, &c.
- Zaccharie Ferreri de Vicence, reformer of Breviary Hymns, xx.
- Zebedee, Sons of, their aim at exaltation, how granted, 139.

THE END



