

THE · YOUNG · FARMER'S



PRACTICAL · LIBRARY



◆ HOME ◆
WATERWORKS
CARLETON · J · LYNDE

TD
927
L99

Cornell University Library
BOUGHT WITH THE INCOME
FROM THE
SAGE ENDOWMENT FUND
THE GIFT OF
Henry W. Sage
1891

A 257808 25/X/11

Cornell University Library

TD 927.L99

Home waterworks; a manual of water supply



3 1924 015 354 776

fine

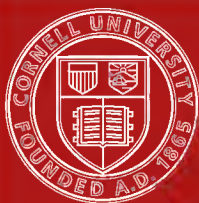

Cornell University
Library

The original of this book is in
the Cornell University Library.

There are no known copyright restrictions in
the United States on the use of the text.

<http://www.archive.org/details/cu31924015354776>

THE YOUNG FARMER'S PRACTICAL LIBRARY

EDITED BY ERNEST INGERSOLL

HOME WATERWORKS

BY

CARLETON J. LYNDE

The Young Farmer's Practical Library

EDITED BY ERNEST INGERSOLL

Cloth 16mo Illustrated each 75 cents *net*.

From Kitchen to Garret. By VIRGINIA
TERHUNE VAN DE WATER.

Neighborhood Entertainments. By RENÉE
B. STERN, of the Congressional Library.

Home Waterworks. By CARLETON J.
LYNDE, Professor of Physics in Mac-
donald College, Quebec.

Animal Competitors. By ERNEST INGERSOLL.

The Farm Mechanic. By L. W. CHASE,
Professor of Farm Mechanics in the
University of Nebraska.

The Satisfactions of Country Life. By
DR. JAMES W. ROBERTSON, Principal of
Macdonald College, Quebec.

Roads, Paths and Bridges. By L. W.
PAGE, Chief of the Office of Public
Roads, U. S. Department of Agriculture.

Health on the Farm. By DR. L. F.
HARRIS, Secretary Georgia State Board
of Health.

Electricity on the Farm. By FREDERICK
M. CONLEE.

Co-operation Among Farmers. By JOHN
LEE COULTER.

HOME WATERWORKS

A MANUAL OF WATER SUPPLY
IN COUNTRY HOMES

BY

CARLETON J. LYNDE

PROFESSOR OF PHYSICS IN MACDONALD COLLEGE, QUEBEC

ILLUSTRATED

New York
STURGIS & WALTON
COMPANY

1911

All rights reserved
L. L.

9391

A78

A.257808

Copyright 1911

By STURGIS & WALTON COMPANY

Set up and electrotyped. Published February, 1911

INTRODUCTION

BY THE GENERAL EDITOR

This is the day of the small book. There is much to be done. Time is short. Information is earnestly desired, but it is wanted in compact form, confined directly to the subject in view, authenticated by real knowledge, and, withal, gracefully delivered. It is to fulfill these conditions that the present series has been projected—to lend real assistance to those who are looking about for new tools and fresh ideas.

It is addressed especially to the man and woman at a distance from the libraries, exhibitions, and daily notes of progress, which are the main advantage, to a studious mind, of living in or near a large city. The editor has had in view, especially, the farmer and villager who is striving to make the life of himself and his family broader and brighter, as well as to increase his bank account; and it is therefore in the humane, rather than in a commercial direction, that the Library has been planned.

The average American little needs advice on the conduct of his farm or business; or, if he thinks he does, a large supply of such help in farming and trading as books and periodicals can give, is available to him. But many a man who is well to do and knows how to continue to make money, is ignorant how to spend it in a way to bring to himself, and confer upon his wife and children, those conveniences, comforts and niceties which alone make money worth acquiring and life worth living. He hardly realizes that they are within his reach.

For suggestion and guidance in this direction there is a real call, to which this series is an answer. It proposes to tell its readers how they can make work easier, health more secure, and the home more enjoyable and tenacious of the whole family. No evil in American rural life is so great as the tendency of the young people to leave the farm and the village. The only way to overcome this evil is to make rural life less hard and sordid; more comfortable and attractive. It is to the solving of that problem that these books are addressed. Their central idea is to show how country life may be made

richer in interest, broader in its activities and its outlook, and sweeter to the taste.

To this end men and women who have given each a lifetime of study and thought to his or her speciality, will contribute to the Library, and it is safe to promise that each volume will join with its eminently practical information a still more valuable stimulation of thought.

ERNEST INGERSOLL.

INTRODUCTION

If I lived in the country without "water on tap in the house," I would read this book again with care, use the information it contains and provide in an economical way this one of the important aids towards satisfactions in house-keeping. The volume in its subject matter and the manner in which that is presented is a valuable guide book to anyone who is thinking of installing a simple water-system or of improving one already in existence. The explanations are so clear and complete that the ordinary intelligent layman is enabled to understand the ways and means to be used to accomplish an end which is desirable for every home.

Water for drinking purposes is a necessity. Therefore that is always provided in quantity although sometimes doubtful in purity. For other household uses the supply is often scanty and not infrequently obtained with unnecessary

labour and in winter weather at the cost of comfort to the women. Want of thinking of the real advantages to the family, want of knowledge of the moderate cost and want of information as to how to go about it, are the chief reasons why this means of grace for health and good living has been neglected in the country. Water in the house, to use lavishly for all wholesome conveniences, seems at first thought beyond the means of frugal people, who have earned by hard labour all they have to spend. It looks to some, who have not closely considered the costs and the benefits, like an extravagance. Instead of that it is one of the greatest of house economies. Almost every farmer could afford the luxury of all water conveniences in his home. These are real luxuries, life their fellows, sunshine, wholesome food and fresh air, which do not weaken the muscular, mental or moral fibres of life. When one has been compelled to use any of these debased for a time how satisfying is the pleasure of purity and abundance.

As an investment for the home I know of nothing likely to yield so much in return in

saving women's strength, in increasing house comforts, in preserving health, in imparting satisfactions in housework and in elevating the general tone of the material side of living. The vague impressions of cost which prevent action should be replaced by adequate knowledge of the essential facts.

The chapters on sources of water supply, and their protection against defilement, are illuminating and should help to prevent disease and what is perhaps quite as damaging. "The effect of impure water is much like that of a dilute poison; it lessens the body's power to resist disease."

The book is suitable for reading and study by children in continuation classes and in High Schools. Everyone would be all the better for having clearer ideas regarding water, its sources, its uses and how the house supply may be protected against dangerous contamination, as Dr. Lynde says in Chapter I,—“All of this tends to bring about that for which we are all striving, a better home and a better chance for the children.” The Bible says in the book of Revelations,—“And he showed me a river of

water of life, pure as crystal, proceeding out of the throne of God and of the Lamb.”

An abundant supply of pure water in the home is one of the means within reach for bringing it nearer heaven.

JAS. W. ROBERTSON.

Feby., 1911,
Ottawa, Canada.

TABLE OF CONTENTS

CHAPTER	PAGE
I VALUE OF WATER INDOORS	3
II FIRST STEPS IN KITCHEN EQUIPMENT	8
III SOURCES OF WATER SUPPLY—UNDERGROUND WATER	27
IV SOURCES OF WATER SUPPLY—WELLS AND THEIR REQUIREMENTS	36
V SOURCES OF WATER SUPPLY—SPRINGS, RIVERS, LAKES AND CISTERNS	58
VI PROPERTIES OF AIR APPLIED IN PUMPS	68
VII PUMPS AND THEIR ACTION	84
VIII STANDARD TYPES OF PUMPS	96
IX RUNNING WATER—GRAVITY SUPPLY AND THE ELEVATED TANK	120
X RUNNING WATER—THE PNEUMATIC TANK	132
XI THE SIPHON—THE HYDROSTATIC PARADOX—THE KINETIC THEORY	147
XII METHODS OF PUMPING—HAND POWER, HORSE POWER AND WINDMILLS	159
XIII METHODS OF PUMPING—THE HYDRAULIC RAM	181
XIV METHODS OF PUMPING—THE HOT-AIR ENGINE	193
XV METHODS OF PUMPING—THE GASOLINE ENGINE AND STEAM ENGINE	204
XVI METHODS OF PUMPING—THE ELECTRIC MOTOR	221
XVII WATER POWER	231
XVIII PLUMBING AND SEWAGE DISPOSAL	244
ACKNOWLEDGMENT	257
FIRMS DEALING IN WATER SUPPLY AND PLUMBING MATERIALS	261
INDEX	267

HOME WATERWORKS

HOME WATERWORKS

CHAPTER I

VALUE OF WATER INDOORS

THOUSANDS of men living in the towns, villages and rural parts of the United States and Canada, out of reach of a public water system, have equipped their homes with water-supply conveniences equal to any found in cities. Thousands more who could well afford to do so and who could do so advantageously, have not done so for various reasons—because the idea has not occurred to them, or because they do not know how to go about it, or because they mistakenly think the expense too great. It is hoped that this book will prove useful to many of these.

An abundance of water in the house is a comfort to every member of the family and a labor-saving convenience for those who do the daily

recurring work of the household. This latter is the strongest reason for placing a water supply system in the home,—it is a labor-saving convenience for women.

This is the age of labor-saving machinery, and in no field of activity is this more apparent than on the farm. There the man's work is lightened by the use of the gang-plow, cultivator, disk harrow, horse rake, hay tedder, mower, binder, corn harvester, potato digger, root cutter, threshing machine, gasoline engine, etc. The advantage of labor-saving machinery in man's work is evident and easily reckoned in time and money saved. The advantage of labor-saving devices in the home is not so easily estimated. The mother's labor is so freely given that we are in the habit of considering it of no money value, whereas, when we think of it seriously, we realize that it is the most valuable asset of the home.

The energy a mother devotes to the work of the home and the care of her children is above money valuation, and anything that conserves this energy and makes it more effective is a gain to the whole family; labor-saving devices

in the home are an aid in this direction, and a water supply system is one of the greatest of these labor-saving devices. With a supply of hot and cold water on tap, with a kitchen sink and set laundry tubs, much of the drudgery of work in the kitchen is eliminated, and the energy thus saved is free to be devoted to the better care of the children and to the enjoyment of life with them.

In the normal home there are two chief workers—the man and the woman. The man, by his labor, provides the raw material; the woman, by her labor, produces from this material the flower called home life. The advantage of labor-saving machinery in man's work, on the farm or elsewhere, is not that he does less work, but that he does more and better work and still has time and energy left for higher forms of work, for self-improvement, and for enjoyment in life. The same is true of labor-saving appliances in the home; the mother does the same work in less time and with less expenditure of energy, and the time and energy saved are devoted to the higher needs of her children, to self-improvement, and

to the enjoyment of life with her family. All of this tends to bring about that for which we are all striving, a better home and a better chance for the children.

The home in the country or small town has many advantages over one in the city; it has fresh food, pure air, plenty of sunshine, and God's good out-of-doors. In one respect, however, the average city home has an advantage over one in the country; it has a water-supply equipment. Happily there has been a great improvement in this condition of affairs in the last few years. Thousands of homes in the country have been equipped with water-supply conveniences; many others are being so equipped; and for still others, such an equipment is being planned. It is hoped that this book will be of service in aiding this good work.

When a man sits down to plan a water supply system for his home, he must decide a number of questions, namely: how to obtain pure water in sufficient quantity; how to bring the water to the house; how to equip the house; and how much it will all cost.

To help answer these questions, the problem

of water supply is dealt with as follows:— Chapter II takes up the equipment of the kitchen and shows that many of the comforts of a convenient water system may be had at moderate cost. In Chapters III to V, the sources of water supply are discussed, showing how pure water may be obtained and how it may be kept pure. Chapters VI to XVII deal with the various pumping and water-supply appliances used in bringing water to the house and barns; and in order to show not only *how* they work but *why* they work as they do, the appliances are explained from the standpoint of the laws of nature upon which they are based. When a man understands the “why” of the various appliances, he is able: first, to choose with intelligence the equipment best suited to his own needs; second, to make any alterations needed to increase the efficiency of the system he proposes to instal; and third, to keep the apparatus in good running order after it is installed. Chapter XVIII deals with the equipment of the bathroom and water-closet, and with sewage disposal.

CHAPTER II

FIRST STEPS IN KITCHEN EQUIPMENT

IN many homes a convenient water system would be installed at once, were it not for the impression that the cost is necessarily very great. From the illustrations given below it will be seen that this impression is erroneous and that many of the comforts of abundant water may be had for a small outlay in materials.

In the typical country or village home the drinking water is obtained from a well and the water for washing from a cistern. Both pumps are outside of the house and all the water used must be carried in pails. This is hard work and it is usually the women who do it. In all kinds of weather, fair or foul, in rain, snow and slush, this water must be carried and the women do it. A little money well spent will bring this water into the house and add much to the health and comfort of the women folk.

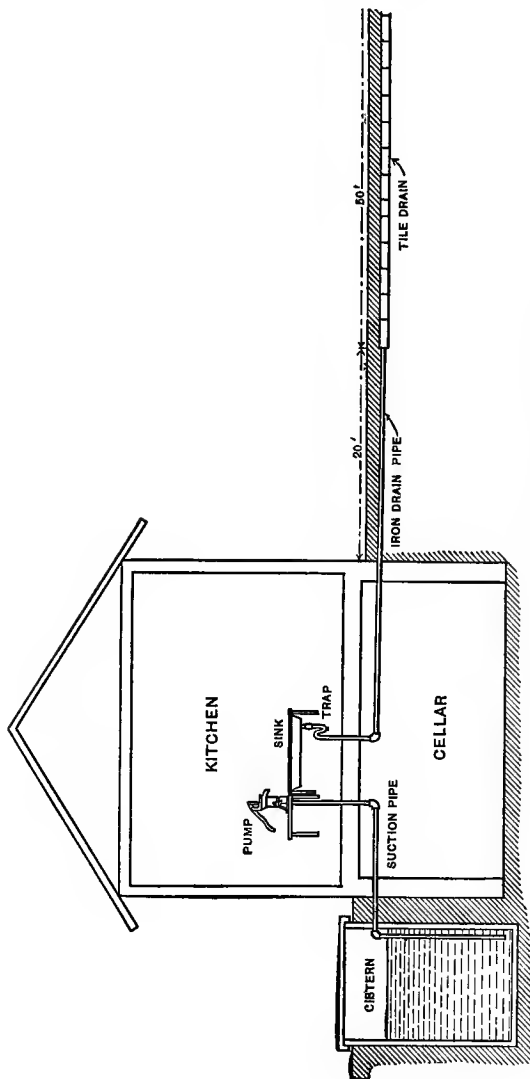

Fig. 1. Kitchen supplied with cistern water, sink and drain.

Cistern pump and sink in the kitchen. If the cistern is just outside the house, as is usually the case, a few feet of piping will bring the water from it into the kitchen and allow the pump to be placed at one end of the kitchen sink. The cost of this is as follows:

From cistern to pump, 20 feet 1¼ inch galvanized iron pipe at 10 cents per foot	\$2.00
Pitcher pump, 3 inch, brass lined	1.85
Porcelain lined sink 18 × 30 inches fitted for 1½ inch lead trap	2.35
Lead trap, 1½ inch, with iron pipe connections	1.40
From trap to drain 25 feet 1½ inch galvanized iron pipe at 12 cents per foot	3.00
50 feet 3 inch drain tile at \$14 per 1,00070
	<hr/>
Total	\$11.30

The prices given throughout this book are for materials only, and do not include the freight or cost of installing. The freight is usually a small item and the work of installing the apparatus may be done by the householder. All the large dealers will cut and thread the piping to the required lengths, if measurements are sent to them. The charge for this is nominal, generally under five cents per cut and

thread. Any man, then, who can use a brace and bit and a pipe-wrench can instal the apparatus.

The prices quoted were obtained partly by correspondence with dealers and partly from the catalogues of large retail-houses. For the convenience of those interested in water-supply equipment, a list of dealers in water-supply and plumbing materials is given at the back of the book. Catalogues and further information as to prices, etc., may be had by writing to these dealers, or to others.

The pitcher pump is described on page 96. It will lift water by suction fifteen or twenty feet. If the lift is greater than this, a well-pump such as that described on page 98 is used.

The sink is an important part of the kitchen equipment. In a great many houses, not only is all the water for drinking and washing carried *into* the house, but all the waste water is carried *out*; this means more needless drudgery for the women. A kitchen sink attached to a good drain, saves all the labor of carrying out the liquid wastes, and at the same time disposes of these wastes in an inoffensive manner. An

S-shaped trap is placed under the sink to prevent the foul air of the drain from coming up into the kitchen. A little water remains in the trap after each discharge and makes what is called a water-seal, which keeps back the foul air.

A proper method of disposing of sewage is a very important part of any plumbing system. The drain shown in Fig. 1 is made as follows: A one and one-half inch galvanized iron pipe runs from the trap to about twenty feet from the house, where it empties into fifty feet of three inch tile set with open joints eight inches below the surface of the ground and at a slope of about three feet in one hundred feet; here the drain ends.

The operation of this drain or sewage disposal plant, as we might call it, is as follows. The liquid waste enters the tile drain and gradually soaks out through the joints into the soil. The water disappears, but the organic impurities are held by the soil grains and serve as food for the millions of bacteria which live in the soil near the surface. These bacteria turn the impurities into harmless substances.

The tile drain is placed with the top only eight inches below the surface in order to take advantage of the good work done by the soil bacteria, which are most numerous near the surface. If the soil about the house is a heavy clay, through which water does not pass readily, the tile should be placed in a trench, about two feet wide and one and a half feet deep, filled with sand or loam, the top of the tile being not over eight inches below the surface.

The drain should be placed on the side of the house opposite to the well, and where the ground has a gentle slope away from the house. It should be placed where it will not be plowed up, as under a lawn or under the grass at the side of a path or road.

This drain will take care of the wastes from sink, laundry tubs, etc., in the kitchen of a moderate-sized family of, say, six or eight people. For a larger family the tile drain may be lengthened to seventy-five or one hundred feet. It will not take care of the sewage from a water closet. Various methods of doing this are described in the chapter on sewage disposal.

In cold climates where such a drain might freeze in winter, it may be protected by a heavy covering of barnyard manure; or the wastes from the kitchen may be carried to a cesspool through fifty feet of three-inch glazed tile placed four feet underground at as steep a grade as possible.

This kitchen equipment, consisting of cistern pump, sink and drain, can be installed at a cost of less than twelve dollars for materials. It adds to the comfort of the home, by doing away with the drudgery of carrying the cistern water into the house, and the waste water out of the house. A further comfort is added to the home by bringing the well water into the kitchen.

II. Well pump in the kitchen. The labor of carrying the drinking water may be saved by placing the well pump at the other end of the kitchen sink. This also gives another source of water supply. If the cistern water fails in a drought, the well water may be used for all kitchen purposes until a fresh supply is on hand. The cost of this depends of course on the distance from the well to the house, and also on the kind of pump used. If the well is, say,

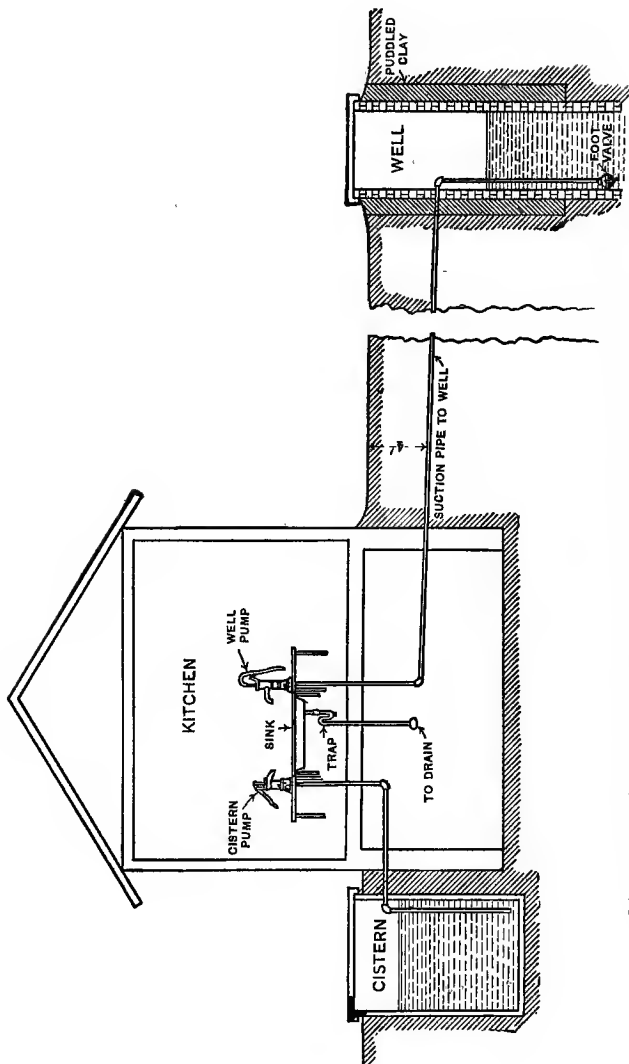

Fig. 2. Kitchen supplied with cistern water, well water, sink and drain.

seventy-five feet from the house, and the vertical part of the pipe is twenty-five feet long, one hundred feet of piping is needed. The cost is:

100 feet 1¼" galvanized iron pipe at 10 cents	
per foot	\$10.00
1¼" foot valve and strainer25
Well pump	3.00
	<hr/>
Total	\$13.25

The foot valve is placed on the lower end of suction pipe in the well and keeps the suction pipe full of water, so that the water comes quickly when the pump is started.

The equipment described under I and II above, decreases the work of the women in the home, since it saves them the heavy labor of carrying great pails of water into and out of the house. If the kitchen is supplied with running water, the work in the home is still further lightened, since the women obtain all the water needed by simply opening a tap, and the labor of pumping may be done by the men of the family or by some form of power pumping.

III. Running water in the kitchen. A supply of running water (Fig. 3) may be obtained by

placing in the attic or on the second floor a storage tank into which water is pumped from the cistern or well. In many cases an oil barrel is used as a storage tank; the head is broken in, the oil drained out, and that which clings to the sides burned off. For a moderate-sized family, one barrel of water is ample for one day's use in the kitchen. When a larger supply is needed two or more barrels may be connected at or near the bottom by one-inch piping, or a wooden or steel storage tank may be used.

The water is pumped into the tank by means of a force pump at the sink, and may be drawn for use through a tap in the spout or through a separate tap. A small telltale pipe is inserted near the top of the tank and drains into the sink, to indicate when the tank is full.

If the cistern is not large enough to supply sufficient water for use at all times, the system should be arranged to use well water part of the time. This may be done, either by replacing the well pump, shown in Figs. 2 and 3, by a force pump with a pipe leading to the tank, or, by so arranging the force pump, shown in Fig.

3, that it may be used to pump either well water or cistern water. To do this the well suction pipe is joined to the cistern suction pipe by means of a lateral "Y," and a gate valve is placed in each suction pipe below the "Y." When cistern water is needed the gate valve in the cistern suction pipe is opened and that in the well suction pipe closed; when well water is needed, the reverse. When both cistern and well water are available, the tank may be filled with cistern water on days when washing and scrubbing are to be done, and with well water on other days.

The cost of the whole equipment shown in Fig. 3, including tank, sink, force pump, well pump, etc., is approximately as follows. (Some of these prices were given under I and II, but they are repeated here to avoid confusion):

Cistern to force pump, 20' 1 $\frac{1}{4}$ " galvanized iron pipe at 10 cents per foot	\$2.00
Force pump, 3" brass lined with tap in spout	5.50
Pump to tank, 18' 1" galvanized iron pipe at 7 $\frac{1}{2}$ cents per foot	1.35
Oil barrel50
Telltale pipe, 20 feet $\frac{3}{8}$ " galvanized iron pipe at 3 $\frac{1}{2}$ cents per foot70

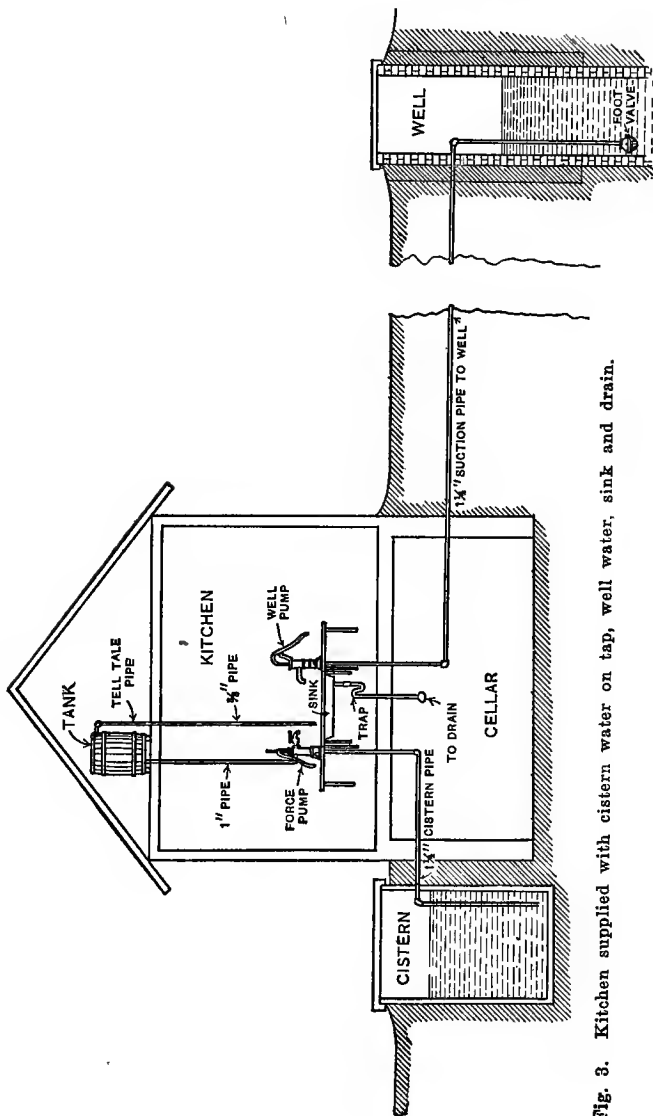

Fig. 3. Kitchen supplied with cistern water on tap, well water, sink and drain.

Porcelain-lined sink 18 × 30", fitted for 1½"	
lead trap	2.35
1½" lead trap with connection for iron pipe..	1.40
Drain pipe, 25 feet 1½" galvanized iron pipe	
at 12 cents per foot	3.00
50 feet of 3" drain tile at \$14 per thousand..	.70
Well pump	3.00
Suction pipe for well pump 100 feet 1¼" gal-	
vanized iron pipe at 10 cents per foot	10.00
Foot valve for suction pipe25
	<hr/>
Total	\$30.75

A few minutes' pumping each morning by the men of the family will fill the storage tank and provide an ample supply for the day's use.

Methods of pumping the water by windmill, hydraulic ram, gasoline engine, etc., are described in later chapters.

With the equipment shown in Fig. 3, the well water is brought to the kitchen sink; the cistern water is to be had by opening a tap; and all waste water is removed by the sink and drain. These are great aids to work in the kitchen. This equipment is good, but it may be made better by adding to it the appliances necessary to provide a supply of hot water on tap. A convenient and abundant supply of hot water in

the kitchen, is probably the greatest comfort of a water supply system.

IV. Hot water on tap. As soon as the kitchen is supplied with water under pressure, from a tank in the attic or otherwise, the com-

fort of an abundant supply of hot water on tap may be had at a small additional expense. The extra equipment needed, as shown in Fig. 4, is a hot-water tank, a water-

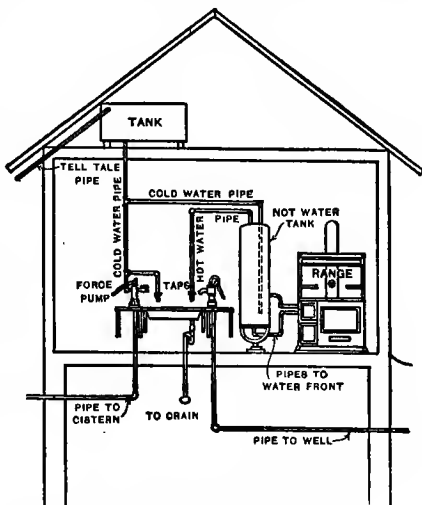

Fig. 4. Running hot water added to kitchen equipment.

front for the kitchen range, and piping to connect the cold-water supply to the hot-water tank, and to deliver the hot water at the sink.

The cost of this hot-water equipment is approximately as follows:

From cold-water pipe to hot-water tank 10 feet 3/4" galvanized iron pipe at 5 1/2 cents per foot	\$.55
30-gallon galvanized iron hot-water tank with stand and brass couplings	6.00
Hot-water front with connecting pipe	3.00
From hot-water tank to sink 12 feet 3/4" gal- vanized iron pipe at 5 1/2 cents per foot65
Hot-water tap50
	<hr/>
Total	\$10.70

The working of this hot-water system is described on page 244 below. In Fig. 4 the telltale pipe is shown projecting from the side of the building beneath the eaves. It is so placed that the water drops in front of a window through which it may be seen from the sink. This arrangement of the telltale pipe may be used in southern houses where there is no danger of its freezing in winter. In northern houses the arrangement shown in Fig. 2, should be used.

With hot and cold water on tap, but one convenience more is needed to make the kitchen equipment complete, namely, a pair of set laundry tubs.

V. Set laundry tubs. The work on wash day is the hardest of the week, and when the ordinary round wooden tubs are used, involving, as they do, the heavy labor of lifting, filling, and emptying them, the work comes under the category of heart-breaking drudgery.

The women may be saved all this unnecessary labor by installing a pair of laundry tubs, as shown in Fig. 5, each tub being fitted with hot and cold water taps and a drain

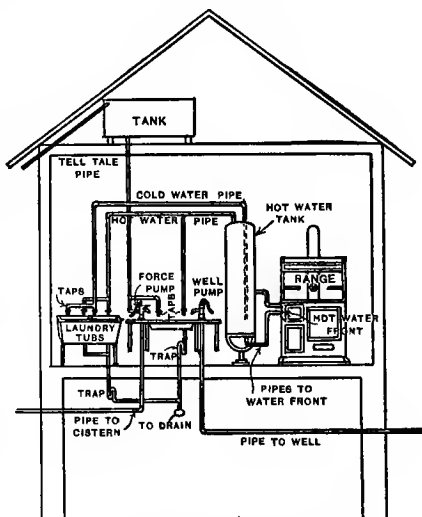

Fig. 5. Set laundry tubs added to kitchen equipment.

pipe; all the labor of filling and emptying them is entirely done away with.

The cost of adding laundry tubs to the equipment of the kitchen is approximately as follows:

Two compartment granitine laundry tubs 48 × 24 × 16", with iron legs, zinc rim, brass plug, strainer and waste connection..	\$ 5.70
4 taps at 65 cents each	2.60
Pipe from cold-water pipe to cold-water taps, 10 feet $\frac{3}{4}$ " galvanized iron at $5\frac{1}{2}$ cents per foot55
Pipe from hot-water pipe to hot-water taps, 10 feet $\frac{3}{4}$ " galvanized iron pipe at $5\frac{1}{2}$ cents per foot55
Trap $1\frac{1}{2}$ " with iron pipe connections	1.40
Iron pipe to drain, 10 feet $1\frac{1}{2}$ " galvanized iron pipe at 12 cents per foot	1.20
Total	<hr/> \$12.00

The laundry tubs take up little room in the kitchen, and if they are covered by a pine top, hinged at the back, they serve as an extra table when not in use as tubs.

In cold climates it is well to place the tubs, the sink and all piping on the side of the kitchen not exposed to the weather. At the same time it should be remembered that a great deal of the cleaning work is done at the sink, and therefore it should be placed in a good light. The kitchen table, range and sink should be close together, and all should be near the pan-

try, because in preparing the food and washing the dishes for a family, three times a day, a woman walks miles, and if the distances are greater than need be, a great deal of unnecessary labor is involved.

The water-supply equipment described in this chapter is a labor-saving device for women, and as with any other labor-saving device the gain is two-fold: first, the same work may be better done, in less time and with less expenditure of energy; second, the time and energy saved may be devoted to higher work. A woman has just so much energy to give to the care of her family. If a great deal of it is used up in such unnecessary drudgery as carrying great pails of water, there is just that much less left to devote to the higher needs of her children.

If we consider the question from the money standpoint—from which standpoint all things must be considered—the total cost of all the appliances shown in Fig. 5 is less than fifty-four dollars. The material will last as long as the house, but if we place the time at forty years, the cost amounts to less than one and one-half

dollars a year. This is not a great price to pay for the increase in comfort; and when we take into account the saving in doctor's bills, and the gain in health and happiness to every member of the family, the outlay must be looked upon as an investment bringing in the finest kind of returns.

CHAPTER III

SOURCES OF WATER SUPPLY

UNDERGROUND WATER

IN Chapter II we dealt with the question of water supply in its relation to the home, and it was shown that many of the conveniences of running water might be introduced into the home at a moderate cost. In this and succeeding chapters the general question of water supply will be considered; beginning with the sources of water supply, then taking up the various methods of pumping water, and ending with a chapter on plumbing and sewage disposal.

Sources of water supply. In the beginning the earth was stored with water, just as it was with air, rock, minerals, etc.; this great store of water is the ultimate source of all water supply. It is made available to us by the heat of the sun which causes water to evaporate (turn

to water vapour) from the surface of land, rivers, lakes and oceans; this vapour mixes with the air and moves with it over the earth's surface; in time it cools, condenses to water, and falls as rain or snow. The water which falls on the land in the form of rain or snow is the source of the water in cisterns, wells, springs, rivers and lakes, and these in turn are the immediate sources of water supply for mankind. There are then three factors involved in water supply: first, the original store of water on the earth; second, the sun which makes this water available in the form of rain or snow; and third, cisterns, wells, springs, rivers and lakes, which are the immediate sources of water supply for mankind.

When rain falls on a field it does not remain there for all time, but leaves in one or all of three ways: it may evaporate, run off over the surface, or sink into the ground. That which evaporates, mixes with the air and in time falls again as rain; the part which runs off over the surface, drains into brooks, rivers, lakes or the ocean, and is subject to evaporation all along its course; that which

sinks into the ground, also finds its way underground to brooks, rivers, lakes or the ocean, and is known as underground or ground water.

Underground water. We are particularly interested in underground water, because the great majority of homes in the country obtain their water supply from wells, and the wells in turn receive their water from the underground supply.

A great deal of the earth's surface is made up of great layers of soil one on top of another, underlaid by further layers of rock. For example, if we should dig down in a field we might find the following: a surface layer of loam; under it a layer of sandy or gravelly soil; then a layer of clay, then a layer of limestone, and under it a layer of sandstone, etc. These layers are called strata and vary greatly in thickness and extent. A pervious or porous stratum is one that allows water to move through it more or less readily, as for example a sandy or gravelly layer. An impervious or non-porous stratum is one that does not allow water to flow freely through it, such as clay and rock strata.

When rain-water falls on a sandy or loamy soil it sinks down until it comes to a non-porous layer; it then moves along on top of this non-porous stratum very much as surface water does on the surface of the ground. There are hills, plains and valleys in the underground strata which as a rule follow more or less closely the contour of the surface stratum, although not always. The underground water flows down the sides of these hills, over the plains and either comes to the surface in the valleys in the form of springs, or flows down the valley through underground brooks, rivers and lakes, until it empties into surface brooks, rivers or lakes farther down the valley.

The movement of the underground water is very slow compared to that of water on the surface, because it moves through a porous layer. Only in rare cases are there actual underground streams like those on the surface. In some limestone regions there are great channels and caves in the limestone rock, in which rivers flow and lakes are formed, as in the Mammoth Cave in Kentucky; but the usual underground stream is a seepage through a porous layer

along the lowest part of a valley in a non-porous layer.

A porous stratum through which water is moving is called a water-bearing stratum, and the surface of the underground water is called the water table or ground water-level.

The surface streams are the natural drains of the country through which they flow, and

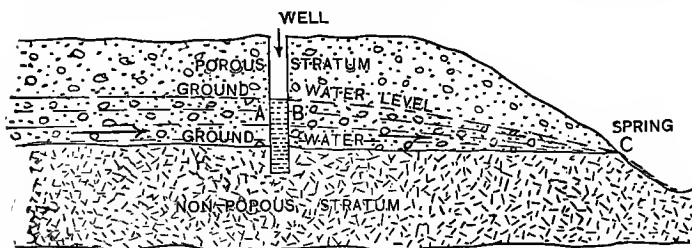

Fig. 6. Underground water, the source of water in wells and springs.

at their edge the ground water-level is the same as the water-level in the stream. At any distance from the stream, however, the ground water-level is always higher than the stream-level.

In Fig. 6 a porous water-bearing stratum is shown lying on a non-porous stratum. The dotted line represents the ground water-level which slopes towards the outlet, a spring in the

valley. The arrows show the direction in which the water is flowing. A well sunk in such a porous layer will be filled with water to the height of the ground water-level. This level rises in wet weather and falls in dry weather, and with it the level of the water in the well. The water in the well is continuously changing; it flows in on the upper side A and out on the lower side B; therefore the water in a well one day, is not the same that was there the day before. All the rain-water that sinks into the porous layer finds its way out into the valley through the spring C or through other springs similarly situated along the side of the valley. This is the source of water in springs.

Artesian wells, bored wells or deep wells. The drawing in Fig. 7 represents a series of strata of large extent, sometimes hundreds of miles. Stratum 3 is porous and has a non-porous stratum above it and another below it. Water falling on the hill between A and B sinks into this stratum, and since it cannot escape downwards through the non-porous stratum below, nor upwards through that above, the water-

level gradually rises until water flows out over the side of the hollow, as at C. If a well is sunk into this stratum, water will rise to the height of the water level fixed by C, and if C is above the level of the surface in the valley, the well is a flowing well. Such a flowing well is called an artesian well. In Fig. 7, D is a flowing well. The top of the well E is above

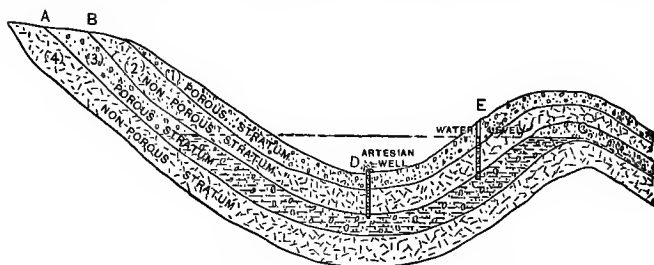

Fig. 7. Conditions producing artesian wells.

the water level fixed by C; therefore water does not flow from it, but rises to the water-level shown by the dotted line. The nomenclature of wells is in a rather unsettled condition. The name "artesian" is properly applied to a flowing well, but it is also commonly applied to any well that penetrates a non-porous stratum and taps a lower porous water-bearing stratum, whether it flows or not. The name

“deep well” is also applied to these wells, as they are usually deeper than the ordinary surface wells. The well is made by drilling and the bore is protected by a wrought iron casing, so that they are also called “drilled” or “cased” wells.

The water which appears in a well has been purified by Nature in two ways, namely, by evaporation, and by filtration through soil. When water evaporates (turns to a vapour) from the surface of fields or from brooks, rivers, lakes or the ocean, all the solid particles are left behind, and when this vapour is cooled and condensed to rain, it is pure water. If, then, after the rain of the first few minutes has washed the impurities out of the air, the rain-water is caught in clean vessels, it is as pure as can be desired. As soon as rain falls on the ground, however, it is contaminated by solid impurities and bacterial growths. If the water sinks into the soil it is again purified, partly by the filtering action of the soil, by which the solid impurities are strained out, and partly by the action of soil bacteria, which retain and destroy all organic matter.

By evaporation then, we are supplied with pure water in the form of rain, and by soil filtration the water contaminated on the surface of the ground is purified before it reaches the wells; that is, if these wells are properly constructed and properly located.

CHAPTER IV

SOURCES OF WATER SUPPLY

WELLS AND THEIR REQUIREMENTS

WELLS are known as dug wells, driven wells or drilled wells, according to the manner of their construction. The purpose in sinking a well is not merely to obtain water, but to obtain water that is pure. Unfortunately, the

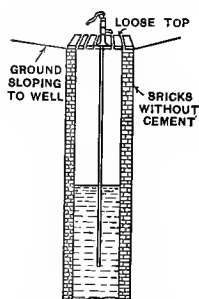

Fig. 8. A poor dug well.

latter point is not always kept in mind.

The dug well. The well shown in Fig. 8 is a poor well, because: first, the top is loose; second, the ground slopes toward the well; and third, it is lined with boards or with stone or brick set without cement.

Since the top is made of loose boards or planks, it is possible for insects, field mice, toads, frogs, etc., to drop into the well and die

there. The water is then comparable to that derived from a graveyard.

Since the ground slopes towards the well, surface washings run into the well during every rain shower, and contaminate the water.

Since the lining is not water-tight, surface water seeps into the well without having passed through a sufficient depth of soil to purify it and the water is contaminated.

Every well should be tested from time to time to determine whether the water is pure, and the best method of doing this is to put some of the water into a sterilized bottle and send it to the government analyst for examination. In many cases, however, a poor well may be recognized without this, as follows:

If the well is like that shown in Fig. 8 it is a poor well.

If after a heavy shower the water pumped up is cloudy, surface water is running into the well without having been properly filtered. The well is a poor one.

If from time to time the remains of dead insects, toads, field mice, etc., appear in the water pail, it is evident that the top of the

well is not properly protected. It is a poor well.

If members of the family are in poor health a great part of the time, the water may be the cause, and a sample should be sent to the government analyst for examination. The effect of impure water is much like that of a dilute poison; it lessens the body's power to resist disease. A strong man who works in the open air may be able to throw off this effect, but it is hard for women and young children to do so. If the resisting power of the body is lessened, a person may be taken down with a disease not directly caused by impure water—tuberculosis (consumption), for instance.

If members of the family have had typhoid fever, or other intestinal trouble, the water is probably the cause; the well may be a poor one. The water should be analyzed.

If the stock have been troubled with hog cholera or glanders, the water is the probable cause. The well is open to suspicion. The water should be analyzed.

If the well is located in a barnyard or within one hundred feet of a privy, it is a poor well.

Errors in locating a well. The well is usually placed near the house for convenience. For the same reason the privy is also located near the house, with the result that they are frequently very close together. The well receives its water from the underground water in the porous layer, but the liquid from the privy drains into this same underground water, and thus the water in the well is likely to be contaminated. (See Fig. 9.)

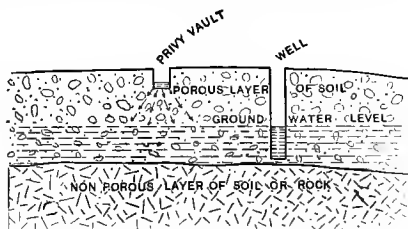

Fig. 9. Privy vault contaminating well water.

The soil is a wonderful purifier of water, but it cannot do the impossible, and sooner or later the well will be contaminated if it is too close to the privy.

Another very common error in locating a well is to place it in a barnyard. The surface of the ground is covered with manure, and in wet weather, especially in the spring and fall, the water which soaks into the well is liquid manure.

The recommendation of sanitary experts is

that a well should be located on ground higher than a source of contamination, such as a privy or barnyard, and at a distance of at least one hundred feet from it.

A good well. A good well is one that gives pure water in abundance. Whether the well will give an abundance of water depends on the nature of the country and somewhat on luck or skill in choosing a good spot to sink it. If other wells in the neighborhood give a good quantity of water, the chances are that water will be found in similar quantity at approximately the same depth.

As to whether the water will be pure depends on: first, the location of the well; second, its construction. The proper location of a well has been discussed above; it should be on higher ground than any source of contamination and at least one hundred feet from it. The proper construction of a well is such that no surface water can enter it without having been filtered by passing through a good depth of soil. It is the opinion of sanitary experts that ordinary surface water is sufficiently purified for drinking purposes if it has passed through ten feet of

soil. This is true for ordinary surface water but does not hold for the leachings from a privy vault or barnyard.

A good dug well. The well shown in Fig. 10 is a good dug well, because it is so constructed that no surface water can enter it

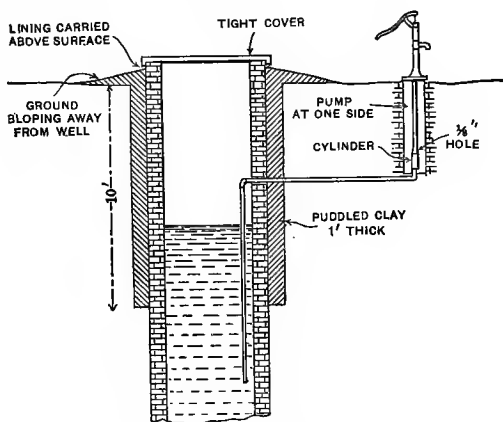

Fig. 10. A good dug well.

without having been filtered by passing through ten feet of soil. It is made as follows:

(1) It is lined with brick, laid dry at the bottom and set in cement for the upper ten feet. The upper ten feet is also backed by a

one-foot layer of puddled clay, which is not porous to water.

(2) The lining is carried nine inches or a foot above the surface and surrounded with puddled clay or cement sloping away from the well.

(3) It has a tight cover.

(4) The pump is placed at one side so that any water spilled does not pass back into the well.

It will be seen that with this construction surface water cannot enter the well without having passed through at least ten feet of soil.

A poor dug well may be improved in a number of ways. Some suggestions are given below. The object, in every case, is so to alter the well that no surface water can enter it without being filtered by passing through at least ten feet of soil. This may be done as follows:

(1) Tear out the old lining and replace it by a lining backed by a one-foot layer of puddled clay as described above, or—

(2) Place a lining of vitrified tile inside the old lining and fill the space between with coarse gravel and sand, the upper ten feet at least being sand, and below that coarse gravel. To admit water, the lower one or two tiles may be perforated; or the bottom of the well may be covered to a depth of one or two feet with coarse gravel and the lower tile placed on this. The joints of the upper ten feet of tiling should be set in cement. With this arrangement the surface water must penetrate at least ten feet of sand before it enters the well. The lining should be carried above the surface and the ground sloped away from the well in all cases; or—

(3) Place in the well an iron pipe with a strainer attached to the lower end, as described under driven wells below. Fill in with coarse gravel to about one foot above the top of the strainer, and above this with sand; or—

(4) The well may be the starting point of a drilled well, in which the surface water is kept out by the wrought iron casing as described under drilled wells below. Since this

well takes its water from the second porous layer, it is not necessary to fill it with sand or gravel.

The driven well. The driven well is a better

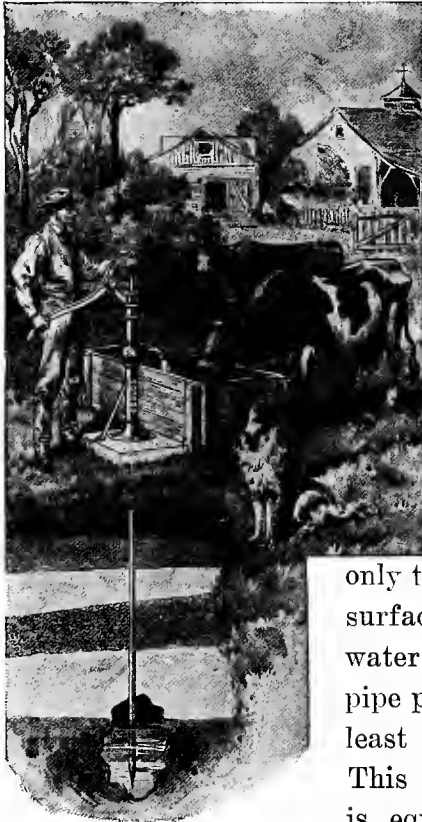

well than the dug well and costs very much less. It is simply an iron pipe fitted with a pointed strainer and driven down into the water-bearing layer (see Fig. 11). If the top of the strainer is

only ten feet below the surface, all surface water which enters the pipe passes through at least ten feet of soil. This driven well then is equal to the good

Fig. 11. A driven well.

dug well described above, because the surface water passes through the same thickness of soil. The cost of construction, however, is very much less; it is about one dollar for piping and about two more for the perforated drive point.

If the point is driven down about twenty-five feet, as is usually the case, all the rain water entering the well passes through at least twenty-five feet of soil. This well then is better than the good dug well described above because the surface water is filtered through a greater depth of soil. It is also very much cheaper, as the only material needed is the piping and the drive-point. The total cost is less than five dollars.

How to drive the well. The perforated drive-point is screwed to one end of a length of pipe and a drive-cap (Fig. 13) to the other. The pipe and drive-point are then driven into the ground with sledge hammers or with a drop weight similar to that of a pile driver. The drive-cap is then removed, another length of pipe screwed to the first, the drive-cap screwed to the top of the new length, the whole driven down, and so on until water is found. A plum-

met is let down inside the pipe from time to time; if it comes up wet, water has been struck. The point must then be driven down somewhat deeper to insure a good flow of water from the porous stratum; this is explained on page 50 below.

Another method of sinking a driven well is to use a pipe without a drive point. A length of ordinary one and a half or two inch galvanized iron pipe is fitted with a drive cap and driven down until the driving becomes difficult; the earth inside is then moistened with water and loosened by means of a drill; the mud thus formed is then removed by means of a sand pump. When the earth has been removed to the bottom of the pipe, the driving is continued. These operations are repeated until the water-bearing stratum is reached; then the drilling is continued for a distance below the bottom of the pipe to form a cavity with loose sides into which the water passes readily from the porous stratum.

The pump may be attached directly to the top of the drive pipe as shown in I, Fig. 12, or the cylinder may be attached to it at the bot-

tom of a dry well, as shown in II, Fig. 12. In either case the drive pipe acts as the suction

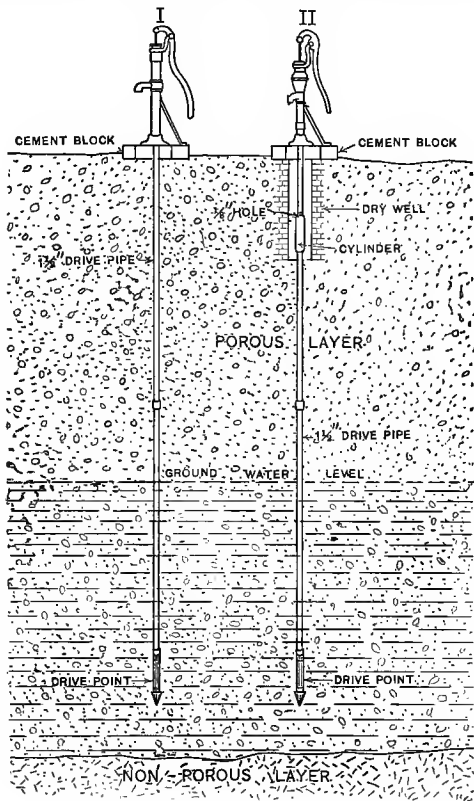

Fig. 12. Driven wells.

pipe and for this reason all the joints must be air tight. The arrangement shown in II is

used to bring the cylinder nearer to the water in the well and also to protect the pump from frost; for this purpose a small hole is tapped in the set length just above the cylinder; this allows the water to run out of the pump as soon as the pumping is stopped.

The drive-well point (Fig. 13) is of galvanized wrought iron, punched with elliptical holes



Fig. 13.



of uniform size and at equal distances apart.

This is covered with brass wire gauze which in turn is protected with a heavy perforated brass jacket. The pointed end or shoe is malleable iron swaged into the pipe and riveted. The drive-points vary in size, of course, according to the type of well; the one most commonly used is one and one-half inches in diameter, twenty-four inches long, with the perforated part eighteen inches long. The price varies also according to size and quality; they are advertised from one dollar up. The drive cap is heavier than the ordinary pipe cap and the thread is cut to the top of the cap, so that when

it is screwed home, the edge of the pipe touches the top of the cap and thus the strain of the driving falls on the edge of the pipe and not on the thread.

The driven well may be used in any soil that allows water to pass through it at all readily. It may be made to pass through a non-porous layer such as clay, into a porous layer beneath. This, in fact, is an excellent arrangement, because surface water does not enter the well at all. The drive-point cannot of course penetrate rock.

When the pump is first started the water brought up is always cloudy, due to the presence of fine particles of sand or grit, but after a little pumping the space about the drive-point is freed from these fine particles, and afterward the water comes up clear.

Depth of well. The amount of water in the drive-well pipe at any time is small, but as soon as the pump is started, water moves into the pipe from the water-bearing stratum. When the pump is working, the water level near the well is lowered and the line of the ground water-level slopes towards the pipe, making

what is called a cone of depression, as shown in Fig. 14. If the soil is very porous, the movement of the water is rapid and the cone is broad and shallow.

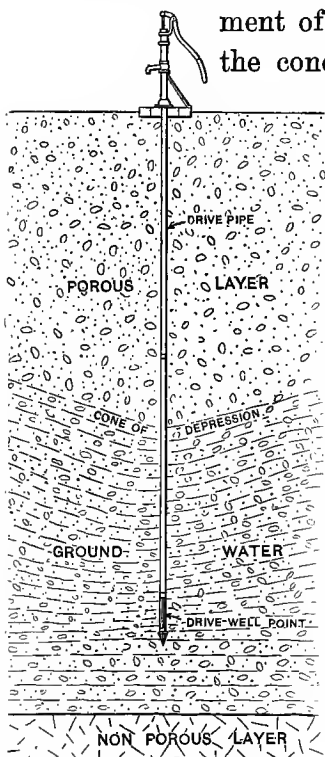

Fig. 14. Cone of depression.

If, however, the soil is not very porous, the cone is narrow and deep, since a greater head is necessary to force the required amount of water through the soil.

The drive-point should always be driven some distance below the ground water-level to make allowance for this lowering of the water-level near the pipe when the pump has been working for some

time. The less porous the soil the deeper it will need to be. The correct depth in each case can be settled only by a pumping test to de-

termine the quantity of water the well gives before it is pumped dry, and the time it takes it to fill again. If the quantity of water is not sufficient, the pipe may be driven down a foot or so and another test made, etc. A well driven without a point improves with use because the water makes for itself channels in the porous stratum through which it moves more readily to the well. This is also true of wells driven with a perforated drive-point, but the efficiency of the latter wells may in time be impaired by the clogging of the wire gauze with sand and grit.

Where the porous stratum is shallow, it sometimes happens that the point is driven through it into a non-porous stratum beneath; this of course shuts off the supply of water. If this should happen, the pipe may be drawn up again as follows: a collar is made of two stout timbers notched to fit the pipe and bolted together around the pipe below the drive cap; the lifting is done by means of two jack screws, one under each end of the collar. If the pipe sticks, a twist or two with a pipe wrench will generally loosen it.

The drilled well. The best type of well is the drilled well. The dug well and the driven well usually receive their water from the surface porous

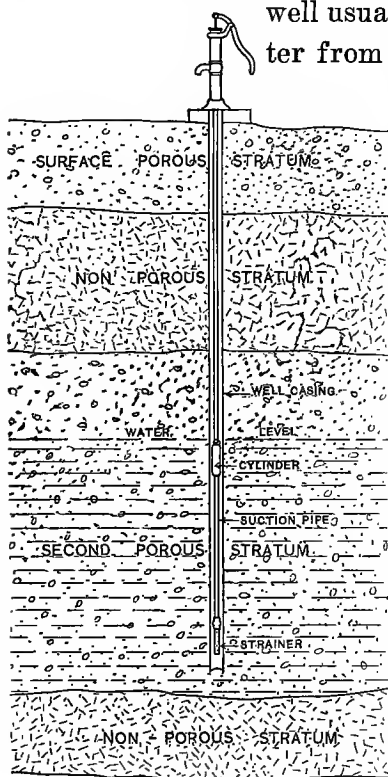

Fig. 15. The drilled well.

layer, and when they are properly located and properly constructed, it is reasonably certain that the water is sufficiently pure for drinking purposes. The drilled well, however, usually receives its water from a second or lower porous layer, as shown in Figs. 7 and 15. Since the water has traveled a great distance

(generally many miles) through the second porous layer it is perfectly filtered, and if

the well is so constructed as to keep out surface water, it is practically certain that the water is free from organic impurities. In any well the water may be hard, because it dissolves limestone and gypsum in its passage through the soil or rock. This is particularly true of the water in a drilled well, because of the greater distance it has traveled.

The drilled well is a hole from three to fifteen inches in diameter, which passes down through the surface layer of soil, and through the non-porous layer of clay or rock below it, into a second water-bearing layer beneath. The bore is protected with a water-tight wrought-iron casing, which, when rock is penetrated, is driven firmly into the rock to exclude surface water, but no casing is used through the rock. If the rock is within twenty feet of the surface, a dry well is dug to it and the casing, after being driven about two feet into the rock, is surrounded with concrete to keep out surface water.

Well drilling is a regular business, since somewhat elaborate machinery is required. The contract is usually made at so much a

foot, and the price averages about two dollars a foot for a four-inch well. This includes the casing and a pumping test of a certain number of hours' duration, to determine the capacity of the well. The drilled well has been in use for many years for irrigating purposes in the western part of the United States and Canada, and it is being rapidly introduced in the east, first, because the water so obtained is pure; and, second, because an ample supply may usually be secured by making the well of sufficient depth.

The pump. The water in a drilled well frequently rises above the surface; that is, it is a flowing well. If the pressure of the water is sufficient, the casing may be connected directly to the supply pipe for the house or barn, and no pumping appliance is necessary. If the water rises within twenty or twenty-five feet of the surface it may be lifted by suction with an ordinary pump placed at the top of the casing. If the water is thirty or thirty-five feet below the surface of the ground a dry well may be sunk five or ten feet below the surface to bring the pump-cylinder within twenty or twenty-five

feet of the water-level. This construction is also used to lower the cylinder below the frost line.

If the water is at a lower level than thirty feet a deep-well pump is used in which the cylinder, with suction pipe and strainer attached, is lowered into the well until the cylinder is below the water level when the pump is working. With this arrangement the cylinder is always primed. The deep-well pump and other pumps used in drilled wells are described in the chapter on pumps.

In Fig. 16 are illustrations of a number of wells showing the pumps in position. The wells as illustrated are of course very much shallower and of greater diameter than they would be in practice. The first on the left is a driven well with a dug well at the top, in which the cylinder is placed below the frost line. The drive-point is a good distance below the water line and the drive-pipe is the suction pipe. Next is a drilled well fitted with a force-pump standard. The cylinder is below the water line and is fitted with a suction pipe with strainer. The third well from the



Fig. 16. Wells with pump in position.

left is a drilled well with a dug well at the top. It is fitted with a pump having a three-way

cock, by means of which water may be delivered above the surface or underground to a service pipe. Each of the pumps in these three wells may be worked by hand or by means of a windmill or other power. Well number four is a drilled well with a dry well at the top. It is fitted with a working head and a pipe placed to deliver water to an underground service pipe. This type of pump is used almost exclusively for very deep wells, and requires a stronger engine than a windmill. Well number five is a dug well fitted with a pump with working head placed four feet beneath the surface. This pump is operated by a windmill or other power. Well number six is a drilled well with a pump having a large delivery pipe above ground. This pump is operated by windmill or other power, and is used chiefly in pumping water for irrigation.

CHAPTER V

SOURCES OF WATER SUPPLY

SPRINGS, RIVERS, LAKES AND CISTERNS

THE source of the water in springs, as is shown in Fig. 6, above, is rain or snow water which has sunk into a porous stratum until stopped by a non-porous stratum below. It flows along on top of the non-porous stratum until it finds an outlet at some lower point where the stratum outcrops.

Springs are a popular source of water supply, and deservedly so, since the water, having penetrated a great thickness of soil, is generally very pure. In some cases, however, the water is open to suspicion; for example, when the spring is on the lower side of a barnyard, or when a privy vault has been placed above and near it. An examination should always be made to determine whether there is a possible source of pollution above the spring.

If the water from a spring is to be piped to the house or barn, the spring should be walled up and fitted with a tight cover (Fig. 17) to protect the water from contamination by insects, toads, leaves, etc. The casing may be a half barrel set down over the spring, or for a more permanent job, may be made of con-

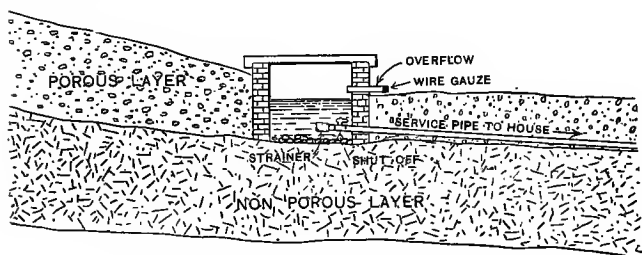

Fig. 17. A spring properly protected.

crete or of brick or stone set in cement. The cover may be an iron plate, a flat stone, or may be made of wood. Of whatever material the cover is made, the chief requirement is that it should fit snugly; because if insects fall into a walled spring, it is harder for them to get out than if the spring were unwalled, and dead insects do not add to the purity of drinking water.

If the spring has not a very large flow the reservoir may be made larger so that the night

flow may be stored for use during the day. If there are several springs near together the water from a number of them may frequently be piped to one reservoir.

The service pipe is fitted with a strainer to keep out anything that might obstruct the pipe, and the overflow pipe is covered with wire gauze to keep out insects.

The service pipe to the house or barn is placed underground to keep the water from freezing; a depth of two feet is sufficient, if the water is allowed to run continuously. If water does not run continuously it must be placed three and a half or four feet underground in cold climates. When the trench containing the pipe is being filled up, the stones should be left out. Stone is a better conductor of heat than earth, and since the water in a pipe freezes because heat is conducted away from it, a water pipe covered with earth containing many stones is more likely to freeze than one covered with earth free from stones. For this reason also, the pipe should not come into contact with the stone foundation wall; it should enter the cellar through a hole about one foot square. If

this hole is left open at the cellar end, the pipe will be protected from frost by being kept at the temperature of the cellar air.

When a pipe is being laid underground, care should be taken to avoid air pockets, and for this purpose, the pipe should be laid on as even a grade as possible. If the pipe is uneven, air from the water collects in the higher parts and forms what are called air pockets, which cut down the effective head and thereby decrease the flow of water. This is not of great importance if the spring has a good elevation or if the pipe is the discharge pipe from a pump, but it is a very important matter if the spring has a small elevation or if the pipe is the suction pipe of a pump.

A well on a hillside. In many cases in a rolling or hilly country, a well sunk on a hillside may be used to deliver water to a house or barn by gravity, as shown in Fig. 18. A glance at the figure will show why this is. The dotted line represents the surface of the groundwater which is flowing through the porous layer and on top of the non-porous layer. A well sunk in the hillside will be filled with water

to the ground-water level, and if this level is above the house a pipe line will deliver water to the house by gravity.

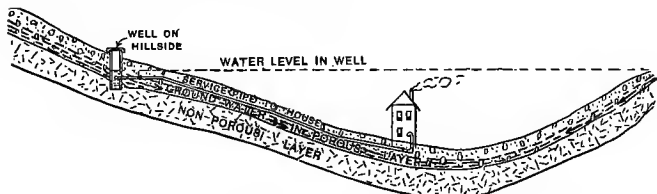

Fig. 18. Water supply from well on hillside.

This is an extremely simple and convenient system of water supply, and might be used much more commonly than it is.

Brooks, rivers and lakes. To take water from brooks, rivers and lakes, the intake pipe should be located in deep water, because: first, it will be less liable to damage by ice; second, as long as there is water in the brook or river there will be a supply for the pipe; and third, the deep water is more nearly free from pollution than that near the side. The method of locating the end of the intake pipe is shown in Fig. 19. It is fitted with a strainer and set a little above the bottom; thus the shifting sediment passes under it and not into it.

The strainer should have an area of open

spaces at least twice the area of the pipe. In rapid streams it should be connected at right angles to the intake pipe and turned so that the open end faces down stream. When the strainer is placed in this position, it readily sheds ordinary floating materials, and those which may cling to it, such as weeds, etc., trail out down stream in such a manner as to leave

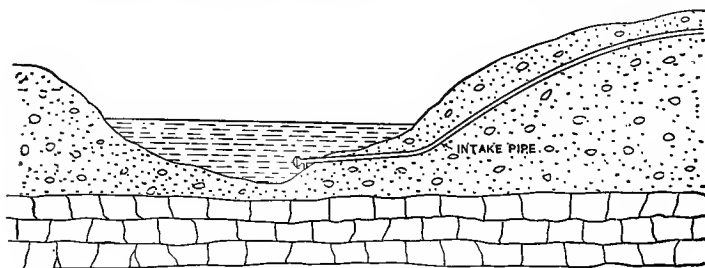

Fig. 19. Intake pipe in river or lake.

the waterway open. It is not advisable to place a foot valve on the end of the intake pipe, because if the valve needs repairing, the whole pipe must be raised from the river bottom. A much more convenient arrangement is to place a swing check valve in the pipe at some point above the water level. It should be placed at the bottom of a dry well and should be of a type easily opened for cleaning and repairs; to

protect the valve from frost, the dry well should be filled with some non-conducting material, such as sawdust, straw or barnyard manure.

Before the water from brooks, rivers and lakes is used for drinking purposes, an examination should be made of the region above the intake pipe to make sure that there is no source of contamination. In thinly settled parts of the country and in mountainous regions the water is generally pure. In the lower and more settled parts, however, this is not the case and every precaution should be taken to see that it is pure.

Well or gallery near a river or lake. A

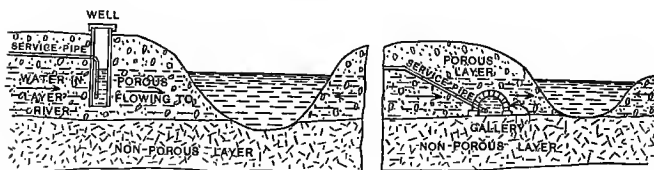

Fig. 20. Well and gallery near river or lake.

method frequently used to obtain water near a river or lake is to sink a well in the bank near the water, or a long gallery is run parallel to the bank, as shown in Fig. 20. It is generally supposed that the water obtained in such a well

or gallery is from the river, but as a matter of fact it is ground-water which is flowing from the land into the river. The dotted line in Fig. 20 represents the ground-water level and the arrows indicate the direction in which the water is moving. It will be noticed that the water enters the well on the land side and leaves it on the water side, and if the well is any distance from the river, the water level in it will be above that in the river.

It often happens that the water in the well differs from that in the river; for example, the river water may be soft and the well water hard, or the reverse. The water in the well is always found to be of the same character as the underground water, which goes to show that it is underground water and not river water.

The same explanation accounts for the fact that wells sunk close to the sea shore generally give fresh water. The impression formerly was that the sand filtered out the salt, but it is now known that the water is fresh because it is water flowing from the land into the sea.

Cistern water. One of the commonest meth-

ods of obtaining water for washing purposes is to gather rain-water from the roofs in cisterns. Rain-water is very pure and if kept so is excellent for all purposes. Since, however, dust, leaves, and bird excrement are usually washed into the cisterns with the water, it is rarely fit to be used for drinking purposes. If

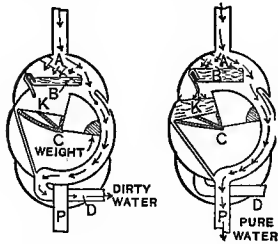

Fig. 21. Rain-water separator.

an automatic device, such as is shown in Fig. 21 is placed in the water pipe from the eave troughs, the first washings from the roof are allowed to run away and then after a few minutes of rain the pure water is turned into the cistern. With such a device in the pipe and with a clean cistern, the rain-water gathered may be used for drinking as well as for washing. The cistern should be thoroughly cleaned once or twice a year.

The device works as follows. The water coming from the roof strikes the tin plate A, which has a few holes in it; the water trickling through these holes slowly fills the small tank

B, below; when B is full it siphons into K, and the weight of this water in K turns the circular part of the apparatus about the axis C, and delivers the water into cistern pipe P. As long as the shower lasts the water trickling through A keeps the apparatus in this position; when the shower is over the water in K leaks out through a small hole, shown in the figure, and the weight moves the apparatus back to its first position, in which it is again ready to discard the dirty water coming from the roof at the beginning of the next shower. The separator might be made still simpler by doing away with the tank B and the siphon; the water would then trickle through A directly into K. There are a number of different rain water separators on the market.

CHAPTER VI

PROPERTIES OF AIR APPLIED IN PUMPS

IN Chapters III, IV and V, we have taken up the various sources of water supply and have learned where the water comes from, how it is purified, and what precautions must be taken to keep it pure. We will now make a study of the various appliances which are used in pumping this water. In order to take care of any piece of machinery one should know not only *how* it works, but *why* it works. In the case of pumps, everyone knows *how* they work, that is, the handle is moved up and down and the water comes; not everyone, however, knows *why* pumps work as they do. This chapter and the next are devoted to a study of the questions, how and why pumps work.

Air. Practically all forms of pumps make use of the physical properties of air, and before we can understand why pumps work, it

will be necessary to know something of these properties of air. Those made use of in the working of pumps are as follows.

First: air has weight. At the surface of the earth a cubic foot of air weighs one and one-quarter ounces, when its temperature is 32° F. Above the surface of the earth air weighs less per cubic foot, because there is less air pressing down on it from above, and therefore its density is less; also, if the temperature is above 32° F., air expands and therefore weighs less per cubic foot.

Second: our atmosphere, which is largely composed of air, exerts a pressure of about fifteen lbs. on every square inch of surface it touches, or over one ton on every square foot.

Third: air is perfectly elastic; that is, it compresses or expands in inverse proportion to the pressure upon it; also it exerts a back pressure equal to the pressure upon it. For example, if we have a certain volume of air confined in the vessel and put double the pressure upon it, it will be compressed to just one-half its volume, and will exert double the pressure it did at first, against the thing which is compressing it.

Similarly, if we make the pressure upon it just one-half what it was at first, it will expand to double its volume and will exert just one-half the pressure it did at first against the thing compressing it.

Air has weight. If one were asked off-hand, the question, "How much does air weigh?" the answer would probably be, "Air has no weight

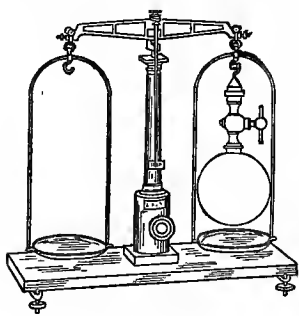

Fig. 22. Weighing air.

at all." When the necessary apparatus (Fig. 22) is at hand, however, a simple experiment may be made to show, that air has weight; that a cubic foot of air at 32° F. weighs one and one-quarter ounces;

and that the air in an ordinary dwelling-house weighs over a ton.

The experiment is as follows. A glass flask, fitted with a tap, is weighed when full of air, and then weighed again after some of the air has been pumped out by means of an air pump (not shown in the figure). It is found in every case that there is a loss in weight, which shows

that the air pumped out has weight. If now, the tap is opened, air will enter the flask again, and on making another weighing we find that the weight is the same as it was before the air was pumped out. This is a further proof that air has weight, since it shows that the air, which enters the flask, has weight.

In order to find out how much air weighs per cubic foot, we proceed as follows.

Weigh the flask when full of air, pump out as much as possible, close the tap, and weigh again to find the *weight* of air taken out.

Now, to learn the *volume* of air removed, we immerse the flask in water and open the tap under water; water enters to take the place of the air removed. If now we weigh it again, to find the weight of water which has entered the flask, we may ascertain the *volume* of water which has entered by dividing the weight of water by 62.5 (the weight of 1 cubic foot of water in lbs.). This gives the volume in cubic feet of the water which entered the flask, and this is the same as the volume of air in cubic feet which was pumped out of the flask. Knowing the weight of air and its volume in cubic

feet, the weight of air per cubic foot may easily be calculated. It is found in this way that a cubic foot of air at 32° F. weighs one and one-quarter ounces.

A house 40 ft. \times 40 ft. \times 20 ft. contains 32,000 cubic ft. of air; that is, $32,000 \times 1\frac{1}{4}$ or 40,000 ozs. of air; that is, 40,000 divided by 16 equals 2,500 lbs. Therefore, a house of the size given above, would hold over a ton of air. This result is rather startling at first, as we are in the habit of thinking that air has no weight at all; but when we remember that balloons and aëroplanes float in air, and that water is lifted in pumps and siphons by the pressure of the atmosphere, the fact is more easily realized.

Air exerts pressure. We have found that air weighs one and one-quarter ounces per cubic foot, and when we remember that we live at the bottom of an ocean of air some miles deep, we readily understand why our atmosphere exerts the pressure it does.

An experiment which may be made by anyone, and which illustrates atmospheric pressure in a striking manner, is as follows. Remove the screw cap from an empty gallon syrup can,

pour in water to the depth of about one inch, place it on a stove and allow it to boil for about five minutes. Then remove it from the stove, screw the cap on firmly and invert it in a shallow dish of cold water; in about half a minute the can will collapse. (Fig. 23.)

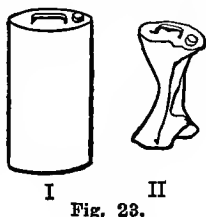

Fig. 23.

The explanation of this is as follows. When the water in the syrup can boils, the steam formed passes out at the top and carries the air with it. After a few minutes of boiling nearly all the air is removed and there is practically nothing in the can but water and steam. When the can is closed and cooled, the steam condenses and leaves a vacuum above the water. There is, therefore, nothing inside the can to press outwards, and since the can is not strong enough to withstand the atmospheric pressure on the outside, it is crumpled up. This illustrates the fact that the atmosphere exerts a pressure.



Fig. 24.

Another simple experiment (Fig. 24) which may be made by anyone, and which shows that

the atmosphere exerts pressure, is as follows.

If an ordinary glass tumbler is filled, or partly filled, with water, and covered with a piece of paper which is held on by the hand while the glass is inverted, it is found that the paper remains on when the hand is removed. The explanation of this is that the atmosphere presses in all directions, sidewise, down and up. In this case the atmospheric pressure upwards on the paper is greater than the weight of water in the glass, and therefore the paper is held on. This shows that the atmosphere exerts pressure upwards.

When an air pump is at hand, a number of interesting experiments may be made to demonstrate the pressure of the atmosphere. Two such experiments are illustrated in Fig. 25. In I, a thin rubber sheet is fastened over one end of a glass cylinder; air is pumped out at the other end, thus decreasing the pressure on the inside; and the atmospheric pressure on the outside forces the rubber sheet in, as shown in II. It makes no difference in what direction the cylinder is held, the sheet is forced in to the

same extent in every position. This shows that the atmosphere presses in all directions, down, up and sidewise, and with the same force in all directions.

Another interesting experiment is as follows.

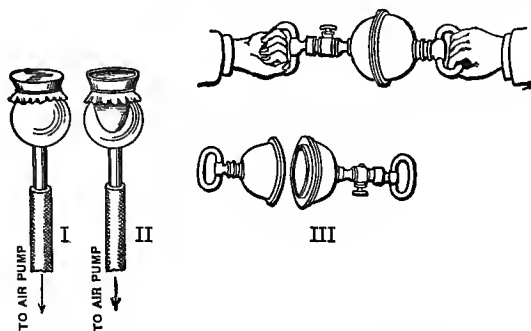

Fig. 25. The atmosphere exerts pressure.

In III is shown a pair of hollow iron hemispheres the edges of which are ground smooth, so that when they are placed together the joint is air tight. One handle may be removed and the air pumped out through the tap. When the air is removed, the tap closed, and the handle replaced, it is found that, with hemispheres of four inches diameter, it is all two strong men can do to pull them apart. When there is air in the inside, the hemispheres fall apart easily;

but when the air is removed there is no pressure from the inside outwards, and the atmospheric pressure on the outside must be overcome in order to separate them. This illustrates the fact that the atmosphere exerts pressure.

Atmospheric pressure nearly 15 lbs. per square inch. We have learned that air has weight and that as a consequence our atmosphere exerts a pressure on everything. Let us now find out just how much this pressure amounts to per square inch.

An Italian named Torricelli (1608-1647) was the first to prove that the atmosphere exerts a pressure, and to measure this pressure. He was led to the discovery as follows. It had been known from ancient times that if one end of a pipe is placed in water and the air is pumped out of the top, the water will rise in the pipe. The ancients explained this by the saying, "Nature abhors a vacuum," which of course was no explanation at all. About 1640 a deep well was dug near Florence and it was found that no matter how perfect the pump, water could be raised only thirty-four feet. It

seemed then that Nature's horror of a vacuum stopped at thirty-four feet. Torricelli came to the conclusion that the true explanation of the fact that water rises in such a pipe is that it is the weight of the atmosphere that forces the water up the pipe, and that this weight is equal to the pressure of thirty-four feet of water. Torricelli reasoned that if this be true, a liquid heavier than water should not be forced up so high as water is, and decided to make a test by using mercury (quicksilver) which is 13.6 times as heavy as water, and therefore should be lifted only 1-13.6 times as high as water.

Torricelli's experiment, 1643. A glass tube four feet long (Fig. 26), closed at one end, was entirely filled with mercury so that no air was left in the tube; the finger was then placed over the open end; the tube was inverted; and the open end, still covered with the finger, was placed in a dish of mercury. When the finger was removed from the open end under

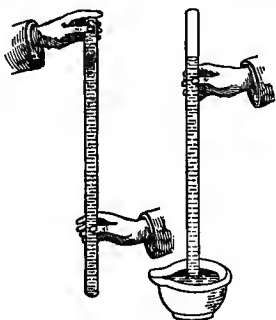

Fig. 26.

mercury, the mercury in the tube remained thirty inches above that outside.

It is found, in making this experiment, that it makes no difference what may be the diameter or height of the tube or dish, the height of the mercury inside the tube is always thirty inches above that in the dish.

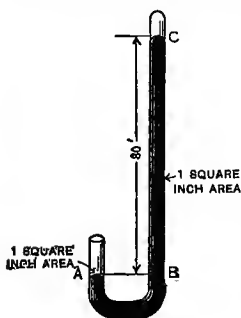

Fig. 27.

If a tube one square inch in inside cross-section shaped like the one shown in Fig. 27, is filled with mercury so that the long arm has no air in it, and then inverted, the level in the long tube remains thirty inches above that in the short tube.

There being a vacuum at the top of the long tube, there is no pressure on the mercury surface at C. The atmospheric pressure then on one square inch at A supports a column of mercury BC thirty inches high. Since the tube is one square inch in area of cross-section, this column contains 30 cubic inches of mercury, and since one cubic inch of mercury weighs .49 lbs., therefore the 30 cubic inches weigh $.49 \times 30 =$

14.7 lbs. The pressure of the atmosphere supports this weight and is therefore equal to 14.7 lbs. on one square inch. This proves that the atmosphere exerts a pressure of 14.7 lbs. on every square inch of surface exposed to it.

Atmospheric pressure will support a column of water 34 feet high.

Since water is only 1-13.6 times as heavy as quicksilver, the atmosphere will support a column of water 13.6 times as high as the column of quicksilver or $30 \times 13.6 = 408$ inches or $408 \div 12 = 34$ feet. That is, if we make an experiment similar to that described in the last paragraph, except that we use water instead of mercury, we find that the column of water supported by the atmosphere is 34 feet high instead of 30 in. high.

If a perfect vacuum could be produced in the ordinary pump the atmosphere would lift water to the plunger valve, even though it were thirty-four feet above the water in the well. In practice, however, this is not possible and twenty-five feet is about the maximum height, while fifteen feet is more common.

Another property of air. We have learned

that air weighs $1\frac{1}{4}$ ounces per cubic foot at 32° F. and that the atmosphere exerts a pressure of 14.7 lbs. (nearly 15 lbs.) on every square inch. (Hereafter we will use 15 lbs. per square inch when speaking of the pressure of the atmosphere.) Another property of air, its elasticity, is made use of in pumps. It is illustrated as follows.

An air-tight cylinder, C (Fig. 28), having an air tap, T, and pressure gauge, G, at the closed end is fitted with an air-tight plunger.

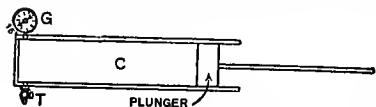

Fig. 28. Air is elastic.

If the tap is opened, when the plunger is in the position represented in Fig. 28 the air in the cylinder is at the same pressure as the air outside, and the gauge registers 15 lbs. per square inch. The gauge registers *absolute* pressure, not the pressure above atmospheric pressure, as is usually the case. On this gauge a vacuum is 0 pressure, atmospheric pressure is 15 lbs., etc.

If now the tap is closed, the air is still at a pressure of 15 lbs. per square inch, but if the

plunger is shoved in far enough to reduce the space that the air may occupy to just one-half what it was at first, as shown in Fig. 29, it is found that the plunger must be shoved in with a force of 30 lbs. per square inch and that the gauge registers a pressure of 30 lbs. per square inch. This shows that to compress a certain

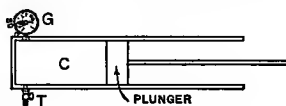

Fig. 29.

quantity of air to one-half its volume we must double the pressure on it; and that when air is compressed to half its volume it exerts twice the pressure it did at first. If the plunger is shoved in still farther, until the space that the air may occupy is just one-third what it was at first, it is found that the piston must be shoved in with three times the pressure, or 45 lbs. per square inch, and that the air exerts three times the pressure it did at first, or forty-five lbs. per square inch. Similarly, if the space is decreased to $\frac{1}{4}$, $\frac{1}{5}$ or $\frac{1}{10}$ the first volume, the pressure is 4, 5 and 10 times what it was at first. In short, if the pressure on air or any gas is multiplied by 2, 3, 4, 10, 20, etc., the

volume is reduced to $\frac{1}{2}$, $\frac{1}{3}$, $\frac{1}{4}$, 1-10 or 1-20, etc., and the air exerts 2, 3, 4, 10 and 20 times the pressure outwards.

Air under decreased pressure. If we decrease the pressure upon the air, it acts in the opposite manner; for example, if we open the tap and shove the plunger in until the volume is small the pressure is 15 lbs. per square inch, since the tap is open. If now we close the tap, and pull out the piston so that the space the air may occupy is twice what it was at first, we find that the pressure inside drops to $\frac{1}{2}$ or 7.5 lbs. per square inch.

Similarly, if we increase the volume the air may occupy to 3, 4 or 10 times what it was at the beginning, we find the pressure it exerts drops to $\frac{1}{3}$, $\frac{1}{4}$, 1-10 what it was at first. In short, if we make the volume which air or any gas may occupy 2, 3, 5 or 10, etc., times as great, the gas occupies the whole volume, but the pressure it exerts, decreases to $\frac{1}{2}$, $\frac{1}{3}$, 1-5 or 1-10, etc., of what it was at the beginning.

This relation between the pressure and volume of gases was discovered by an Englishman named Robert Boyle in 1666. It is called

after him, Boyle's Law, and stated in scientific language it is, "the volume of a gas varies inversely as the pressure upon it," and "the pressure a gas exerts is equal to the pressure exerted upon it."

CHAPTER VII

PUMPS AND THEIR ACTION

WE have now learned some of the properties of air, namely: First, a cubic foot of it at thirty-two degrees Fahrenheit weighs one and one-quarter ounces; second, the ocean of air (our atmosphere) exerts a pressure of fourteen and seven-tenths pounds (nearly fifteen pounds) per square inch or over a ton ($14.7 \times 144 = 2116.8$ lbs.) per square foot; third, air is elastic, that is, its volume varies inversely as the pressure upon it, and it exerts a pressure equal to that exerted upon it. We will now use this knowledge of the properties of air to help us understand *why* the different parts of the pump work as they do.

Classes of pumps. Pumps are divided into two classes: first, *lift pumps*, in which water is raised to the level of the pump spout; and second, *force pumps*, in which water is raised above the level of the pump.

The lift pump. The drawings in Fig. 30 show the different parts of the lift pump. In I

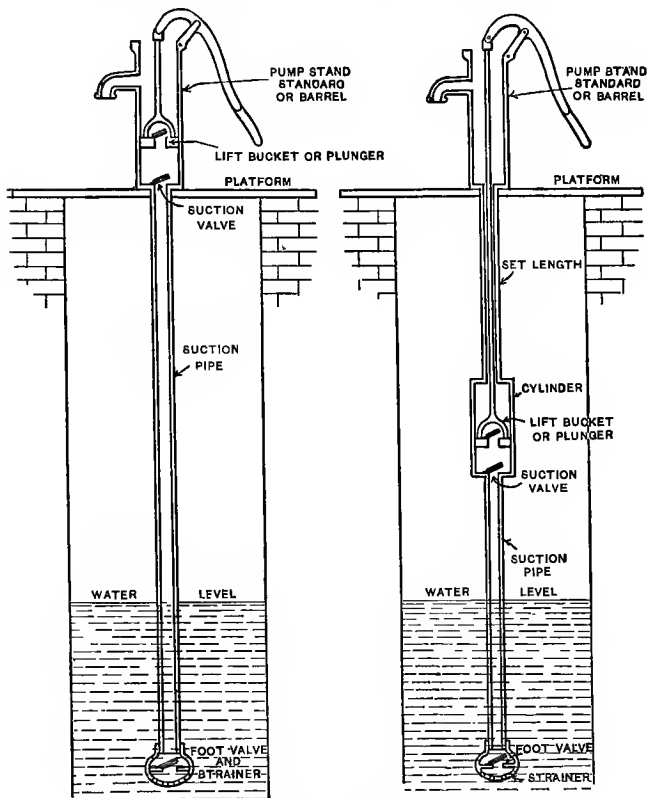

Fig. 30. Lift pumps.

the lift bucket or plunger works in the pump barrel. One valve is in the plunger and the

other, the suction valve, is at the bottom of the barrel; both valves open upwards. Below the suction valve is the suction pipe, and at the lower end of the suction pipe is the foot valve and strainer. The foot valve is not an essential part of the pump, but it is generally used on long suction pipes. It helps the suction valve to keep the pipe full of water, and thus water is obtained quickly when the pump is started. In II the pump is the same except that the cylinder is below the barrel and is connected to it by a four-foot set length. This arrangement is used to decrease the suction distance by bringing the cylinder nearer to the water in the well. It also helps to make the pump anti-freezing. For this purpose a small hole is tapped in the pipe just above the cylinder; this allows the water to drain out of the pump as soon as the pumping is stopped.

The drawings in Fig. 31 illustrate how and why the lift pump works. In general the action of the pump is as follows. The first two or three strokes of the plunger pump the air out of the barrel and pipe of the pump, and thus decrease the atmospheric pressure

on the water in the pipe, and the *atmospheric pressure on the water in the well* forces the water up the pipe and into the barrel. After this the plunger lifts water against the pressure of the atmosphere and the atmospheric pressure on the water in the well forces more water up the pipe and into the barrel.

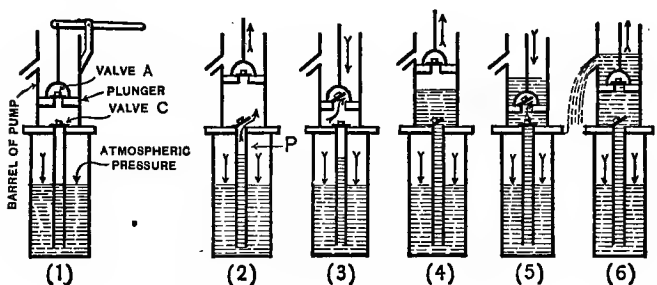

Fig. 31. How and why pumps work.

Let us follow this operation step by step.

In (1) the pump is full of air at atmospheric pressure. In (2) the plunger is being raised, the air in the barrel of the pump is thus given more room and expands to fill it; this decreases the air pressure on the valve C; the air in the pipe P, being thus at a greater pressure than that in the barrel, lifts the valve C and expands into the barrel. This decreases

the pressure on the water in the pipe P, and the atmospheric pressure on the surface of the water in the well forces some water into the pipe. In (3) the plunger is moving down and some of the air in the barrel escapes through the valve A; the air in the pipe remains the same, since valve C is closed. In the next one or two upstrokes the operation illustrated in (2) is repeated until the air in the pipe and barrel is removed, and until the atmospheric pressure on the water in the well has forced water into the barrel. After this the water above the plunger is lifted, against the atmospheric pressure by the up strokes of the plunger, and the atmospheric pressure on the water in the well forces water into the pipe and barrel.

We see then that a pump does not *draw* water, that is, it does not exert a pull on the water, but the plunger decreases the air pressure inside the pump, and the pressure of the atmosphere on the well water forces water into the pipe and barrel.

The force pump. In one style of force pump (Fig. 32) the plunger is solid. The suction

valve is at the bottom of the barrel of the pump just as in the lift pump, and the second valve is at the entrance of the discharge pipe. The first up stroke of the plunger gives more room to the air in the barrel. It expands to fill the whole space and the air pressure in the barrel and on the suction valve is decreased. The air in the suction pipe, being thus at a greater pressure, forces up the suction valve and expands into the barrel. This decreases the air pressure in the pipe and the atmospheric pressure on the water in the well forces water into the pipe until the weight of water, plus the air pressure in the pump, is equal to the atmospheric pressure on the water in the well.

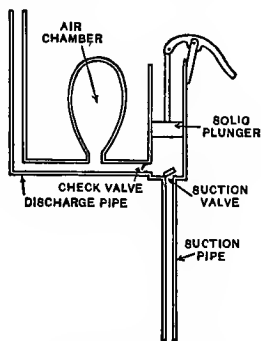

Fig. 32. Force pump with solid plunger.

On the first down stroke the suction valve closes and air is forced into the discharge pipe. The next two or three up and down strokes repeat this operation, and the air pressure in the pump is decreased to such an extent that

the atmospheric pressure, on the water in the well, forces water into the barrel of the pump. After this, the up strokes lift the atmospheric pressure from the water in the barrel and the atmospheric pressure on the water in the well drives more water into the barrel. On the down strokes, the water in the barrel is forced partly into the air chamber, and partly into the discharge pipe. The air chamber keeps up a continuous stream by forcing water into the discharge pipe while the plunger is on the up stroke.

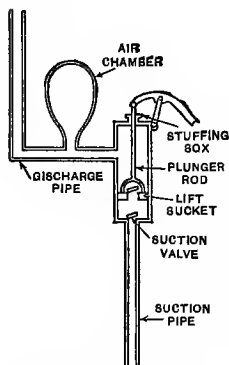

Fig. 33. Force pump with lift bucket.

The type of force pump in common use (Fig. 33) is like the lift pump, in that one valve is at the bottom of the cylinder and the other in the plunger. It differs, in that the top of the pump is closed and there is usually an air chamber on the discharge pipe. In some the top is closed by a water-tight stuffing box through which the plunger rod works (see Fig. 33). In others the plunger rod passes down

through a pipe, at the bottom of which there is an upper cylinder in which an upper plunger-bucket works. This serves to keep the water from flowing out at the top of the pump and also forces water into the discharge pipe on the down stroke (see Fig. 38). In this style of pump the barrel of the pump is generally used as an air chamber.

The air chamber makes the stream continuous. The air chamber is placed on the discharge pipe to prevent strains and to keep up a continuous supply of water in the discharge pipe. Its action, in keeping up a continuous discharge, is based on Boyle's Law mentioned above; namely, when the pressure on a gas is increased or decreased, its volume decreases or increases and the change in volume is in the inverse ratio to the change in pressure; also, air exerts a back pressure, equal to that upon it.

If at the beginning the chamber is full of air at atmospheric pressure, 15 lbs. per square inch, then when the air has been compressed to one-half its volume the pressure is two atmospheres, 30 lbs. per square inch, or 15 lbs.

per square inch above the pressure of the atmosphere. When the air is compressed to one-third its volume the pressure is three atmospheres, 45 lbs. per square inch, or 30 lbs. per square inch more than atmospheric pressure, etc.

On the up stroke of the plunger in Fig. 33 water is driven partly into the discharge pipe and partly into the air chamber. The air in the chamber is compressed and, during the down stroke of the plunger, it expands and forces water into the discharge pipe and thus keeps up a continuous stream.

Air chamber prevents strains. The air chamber prevents strains because of the following facts. Water is practically incompressible and it can escape from the discharge pipe at only a limited rate. If there is no air chamber and the pump and discharge pipe are full of water, any extra force exerted by the engine must be taken up in some way. The water cannot do this, therefore it is taken up by the pump or engine, that is, the pump or engine gives at some point and is strained. If, however, there is an air chamber, any extra force is taken up

in compressing the air and all straining is prevented.

Air chamber on the suction pipe. When the suction pipe is long, an air chamber is generally placed on it near the pump. Its action in this case is two-fold: first, it brings the water, moving in the long suction pipe to rest gradually, and thus prevents strains in the pump and suction pipe; second, it prevents jars on the plunger bucket and rod, on the up stroke of the piston. This is its chief function, which may be explained as follows.

Let us suppose that the distance from the water in the well to the bottom of the plunger is 12 feet. This height of water gives a pressure of about 5 lbs. per square inch. At the instant the plunger ends the down stroke and is just beginning the up stroke, the pressures are as represented in Fig. 34. On the water

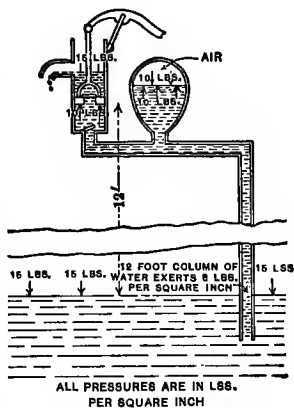

Fig. 34. Air chamber on suction pipe.

in the well the pressure of the atmosphere down is 15 lbs. per square inch. Against this is the weight of water in the suction pipe, 5 lbs. per square inch; this leaves $15 - 5 = 10$ lbs., pressing upwards on the bottom of the piston, and on the air in the chamber. The air in the chamber presses back on the water with the same force, namely, 10 lbs. per square inch.

The atmosphere presses down upon the plunger and therefore the engine, lifting the plunger, lifts $15 - 10$ or 5 lbs. per square inch. This is the lift if the plunger moves up so slowly that the atmospheric pressure on the water in the well has time to set the water in the suction pipe in motion, and keeps it pressing against the bottom of the plunger at the rate of 10 lbs. per square inch. When the plunger moves up rapidly, however, the water cannot be set in motion quickly enough to follow it, and the whole pressure of the atmosphere, 15 lbs. per square inch, is thrown on the plunger. The air chamber comes into effect here; as soon as the plunger begins to rise, the air in the chamber expands, and since there is very little water between it and the plunger,

it sets this water in motion quickly and keeps it pressing against the bottom of the plunger and decreases the lift for a short time. During this time the water in the suction pipe is set in motion by the atmospheric pressure on the water in the well and thus the pressure of the water upwards against the plunger is maintained at a little under 10 lbs. per square inch, and the lifting force required on the piston is uniformly a little above 5 lbs. per square inch. That is, if the pump has no air chamber on the suction pipe and the plunger is moving rapidly, the weight on the plunger, for a short time at the beginning of the up stroke, is 15 lbs. on each square inch of area of the plunger; whereas if the pump has an air chamber on the suction pipe, the weight on the plunger, during the whole up stroke, is very much less, in this case a little over 5 lbs. on each square inch of area of the plunger. Thus without an air chamber, there is an extra strain on the plunger, plunger rod and engine at the beginning of each up stroke; but with an air chamber, there is no such extra strain.

CHAPTER VIII

STANDARD TYPES OF PUMPS

The pitcher pump. The pitcher pump (Fig. 35) is generally used to lift water from a cistern or well to the kitchen sink. It is a lift



Fig. 35. Pitcher pump.

pump similar to that described on page 85. One valve is in the plunger; the other—the suction valve—is at the bottom of the cylinder which is also the body of the pump. The suction pipe is attached to the body of the pump below the suction valve. The handle is reversible so that water may be pumped from any side.

If a perfect vacuum could be produced in a pump, the pressure of the atmosphere on the water in the cistern would force water up thirty-four feet in the suction pipe and cylinder. In practice, however, a perfect vacuum cannot be produced in a pump, and as a result the pump

cylinder is generally so placed that the plunger valve comes within fifteen or twenty feet of the water level. The usual distance for the pitcher pump is fifteen feet or less.

The house force pump. The house force pump (Fig. 36) is usually placed at the kitchen sink to pump water from a cistern or well into a tank in the attic. There is a valve in the plunger and another at the base of the cylinder, as in the pitcher pump. The plunger, however, works through a stuffing box at the top, which prevents water from escaping when the pump is being used to force water above the level of the pump.

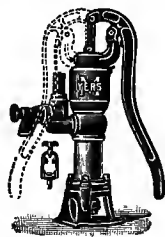

Fig. 36. Force pump.

The pump rod is jointed, to allow that part of it which is in the barrel to move in a vertical direction only. The cock in the spout of the pump, shown in Fig. 36 has three uses. When it is out, it closes the spout so that water may be forced from the pump to an elevated tank; when it is in, it closes the discharge pipe from the elevated tank, so that no water can pass from this pipe to the pump or spout. The

pump, may then be used as an ordinary lift pump. When the cock is half in and half out, water flows from the tank through the discharge pipe and out at the spout, or in other words, in this position it serves to draw water from the elevated tank.



Fig. 37.
Well lift
pump.

The handle of this pump is reversible and the pump is usually placed fifteen feet or less above the water level.

Well lift pump. The pump shown in Fig. 37 is a typical well lift pump; the part above the well platform is called the pump standard. The pipe from the standard to the cylinder is called the set length. The suction pipe, not shown in the figure, is attached to the lower end of the cylinder. The object in placing the cylinder below the well platform is two-fold:

first, the suction distance is decreased, because the cylinder is brought nearer to the water in the well; second, the pump is made anti-freezing, because the cylinder is below the frost line, and a small hole tapped in the pipe just

above the cylinder allows the water to flow out of the body of the pump when pumping is stopped.

The set length is usually four feet long, but this is not sufficient if the water in the well is very deep or if the climate is very cold in winter. For good suction the bottom of the cylinder should be within fifteen feet or less of the water in the well, and the best arrangement is to place the cylinder in the water. For very cold climates it is well to place the cylinder ten feet below the platform and better to place it in the water.

The pitcher pump and cistern force pump described above cannot be made anti-freezing in this manner, because the cylinder is in the pump standard, but this is accomplished by so arranging them that when the handle is raised to its full height, the plunger is let down to the bottom of the cylinder and trips the valves; that is, opens both valves, whereupon the water runs back into the well.

Well force pump. In the force pump shown in Fig. 38 the pump standard is the part above the well platform, below this is the set length,

then the cylinder, and the suction pipe (not shown) is attached to the lower end of the cylinder. The whole inside of the standard acts as



Fig. 38. Well force pump.

the air chamber; water is forced into it on each half stroke of the plunger, whereby the air is compressed and forces the water out through the discharge pipe in an even stream. The plunger rod passes down through the inner tube of the set length and the water passes up in the space between the inner and outer tube.

There are two plungers on the plunger rod; the lower one works in the outer cylinder and the upper one in the inner cylinder. The inner cylinder has just one-half the volume of the lower half of the outer cylinder. On the up stroke the lower plunger or lift bucket lifts water, of which half passes into the inner cylinder, and half up towards the air chamber. On the down stroke, that which passed into the inner cylinder is forced up towards the air cham-

ber. The pump, then, is double acting in the sense that it forces water into the air chamber at each half stroke, but it is not entirely double acting because it draws water from the suction pipe only on the up stroke. A small hole is tapped in the outer pipe of the set length, to allow the water to run out of the pump when pumping is stopped; that is, the pump is anti-freezing.

In deep wells the cylinder is divided; the inner cylinder, in which the plunger bucket works, is placed five feet below the well platform, and the outer cylinder, with the suction valve, is lowered into the water. The lift bucket works in the lower cylinder, and is joined to the upper plunger, by a three-eighths-inch steel rod. The frost vent may be placed at any point in the pipe, above the lower cylinder.

This pump may be used in any kind of well, but is especially designed for drilled wells. The cylinders are made small enough to pass through a well casing three inches in diameter. They are designed for wells of any depth to one hundred and fifty feet.

The branch pipe force pump. This pump

(Fig. 39) is so arranged that it will deliver water either to the spout above the platform or to an underground service pipe. The pump is fastened to the platform by a ring base not shown.



The suction or supply pipe is attached at the end of the lower cylinder marked "supply." The lower cylinder in which the lift bucket works may be placed as shown in the figure, when the pump is used in a shallow well or cistern. In deep wells, however, it is lowered into the water, and the plunger rod and connecting pipe are lengthened; the upper cylinder, in which the plunger bucket works, has the position shown,

whether the well is shallow or deep. The pump is double acting, in the same sense that the pump last described is; that is, it forces water to the discharge pipe on each half stroke, but draws water from the suction pipe only on the up stroke. The

Fig. 39.
Branch
pipe
force
pump.

standard, which is also the set length in this case, is a one-and-one-half-inch steel pipe. It is closed at the top and acts as the air chamber.

The three-way cock is placed four feet below the well platform and the water is directed to the spout or to the underground service pipe by means of the cam movement above the spout. The pump as shown may be operated by hand or power.

The siphon force pump. This pump (Fig. 40) is designed for use where the pumping appliance is not directly over the source of water supply; as for example, when water is being pumped from a stream or lake, and the windmill and pump are placed on the bank with the suction pipe extending into the water; or, when the windmill is on the barn, the pump is placed in the stable beneath,

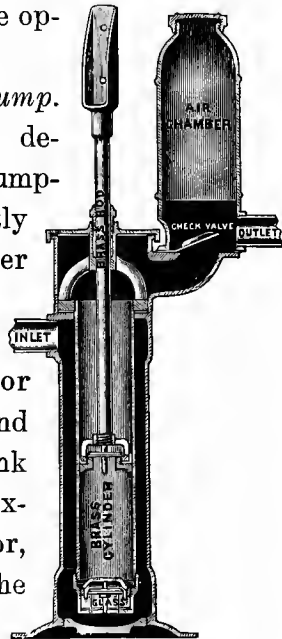

Fig. 40. Siphon force pump.

and the suction pipe extends to a well, stream or lake outside. It is used to pump water into an elevated tank and has a large capacity. It will lift water by suction the usual distance ver-

tically, and any distance up to five hundred feet horizontally.

The name siphon is rather misleading, as one is apt to think that this is an important part of the pump. There is a slight siphonage, since the inlet pipe is above the suction valve. For example, if this distance is one and a half feet, there is a siphonage of this amount, but this does not, and cannot, increase the height the pump may be placed above the water level. The gain in having the inlet pipe above the suction valve is that there is always some water left in the cylinder and thus the cylinder is always primed.

A good feature of this pump is, that by removing the top, the lift bucket and suction valve may be examined without disturbing the suction or discharge pipes.

Double-acting low-down force pump. The force pump shown in Fig. 41 is a true double-acting pump, because it draws water from the suction pipe and forces it into the discharge pipe at each half stroke. It is really two pumps in one, for there are two suction valves and two discharge-pipe check valves. Only one

suction pipe and one discharge pipe are used, however, because only one suction valve and one discharge valve are working at any one time. The plunger is double and moves horizontally in a single cylinder which is open at both ends.

The fact that the handle moves in a horizontal direction makes the pumping easier. In working an ordinary up-and-down-handle, a great deal of the work a man does is used in lifting the upper part of his body on each up stroke. This work is not done on a horizontal stroke and therefore the work is easier. The cog-wheel-and-ratchet arrangement of the handle and plunger also makes pumping easier: first, because the plunger rod has a straight-line motion and therefore there is little friction in the stuffing box; second, because the handle has its full leverage in all positions;

third, because the roller bearing at the back of the plunger rod decreases the friction on that

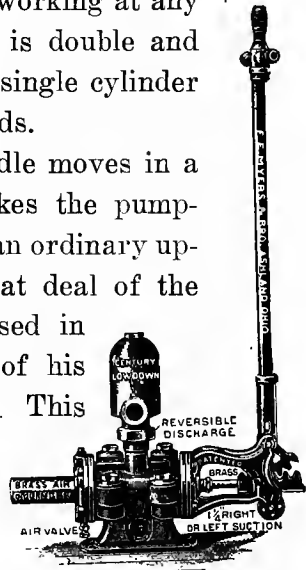
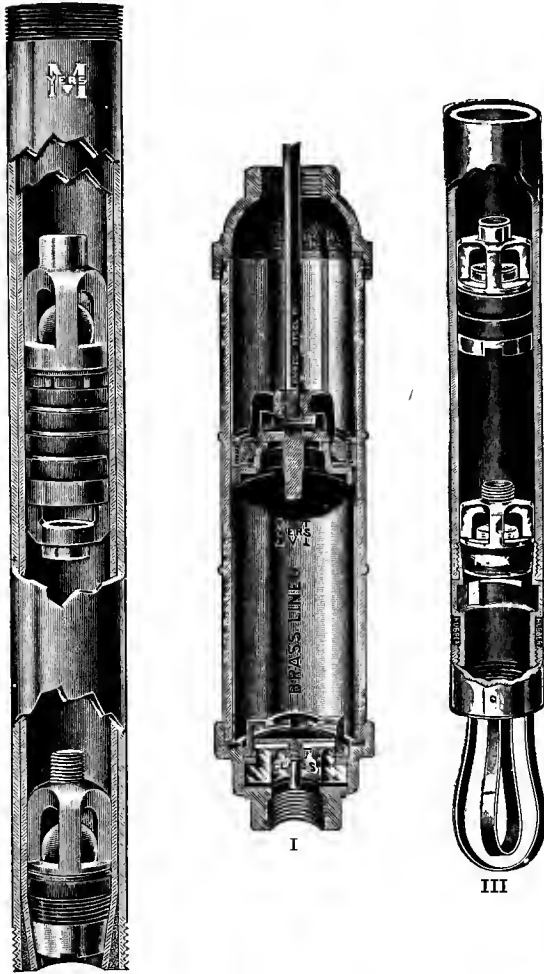

Fig. 41. Double-acting low-down force pump.

side. The pump will lift water the ordinary suction distance, and it is used to force water from a well or cistern into an elevated tank or into a pneumatic tank. The pump shown in the figure has a special arrangement for pumping air, when it is used in connection with a pneumatic tank. The air pump is the small cylinder shown at one end of the pump; it has a plunger connected to the main plunger rod. When air is needed in the tank, a tap is turned and air is forced into the discharge pipe with the water. When the tap is reversed, the air moves in and out of the cylinder at each stroke but is not forced into the discharge pipe.

Deep well cylinders. The cylinders shown in Fig. 42 are used in deep wells. They are placed at a sufficient depth to be below the water level when the pump is working at its normal rate; and they are connected to the working head of the pump by a discharge pipe through which the plunger rod works, and through which the water passes to the service pipe at or near the surface. Cylinder I is made especially strong for heavy work, the spring assuring quick closing of the plunger valve on the



II

I

III

Fig. 42. Deep well cylinders.

up stroke. Cylinder II with ball valves is the one in most common use for very deep wells. It is made one size smaller than the discharge pipe so that the lift bucket and suction valve may be removed for repairs without disturbing the discharge pipe. Cylinder III does not require a discharge pipe to hold it in place; it is fitted with an expansion ring by means of which it can be fixed at any point in the well casing. With this cylinder, the well casing serves to carry the water to the surface and the cost of a discharge pipe is saved.

The rotary pump. The rotary pump (Fig. 43) has neither plunger nor valves. It consists of a casing in which two runners revolve in opposite directions. The smaller pumps make from one to two hundred revolutions per minute, the larger ones used for fire purposes make as many as three hundred and fifty revolutions per minute. The suction pipe enters the casing at the bottom and the discharge pipe at the top.

The pump works as follows: The runner blades move upwards in front of the suction pipe and carry air with them. This creates a

partial vacuum in the suction pipe, and the atmospheric pressure on the water in the well forces water up the suction pipe into the casing. As soon as the water is forced above the runner blades it is driven by them into the discharge pipe, and a fresh supply is forced into the cas-

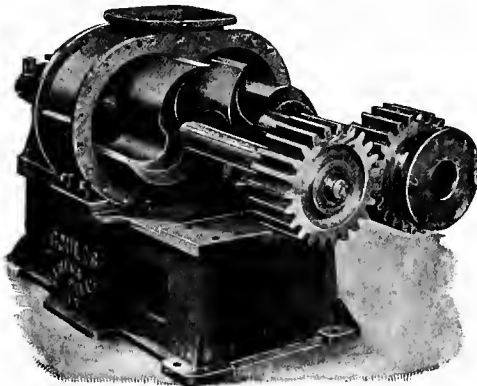

Fig. 43. Rotary pump.

ing by the atmospheric pressure on the water in the well. Rotary pumps lift water by suction the usual suction distance; the small pumps have a total lift, suction and discharge, of about seventy-five feet; the large fire pumps have a total lift of several hundred feet. Rotary pumps are usually driven by some form of engine.

The centrifugal pump. The centrifugal pump (Fig. 44) also has neither plunger nor valves except, in some cases, a check valve on the suction or discharge pipe. It consists of

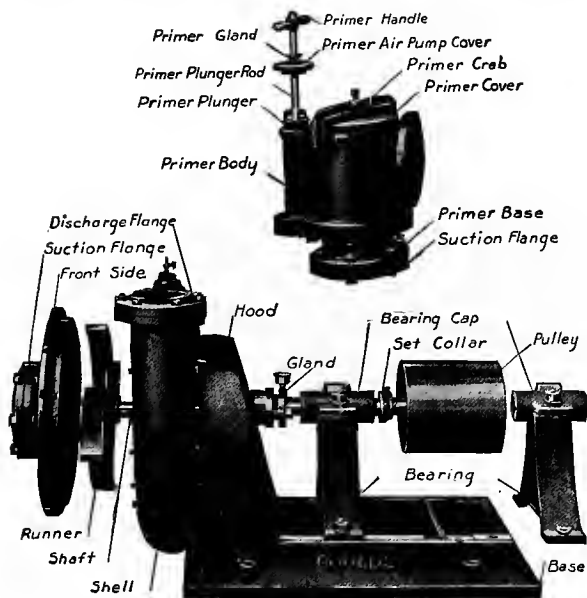

Fig. 44. Centrifugal pump.

a cylindrical casing inside of which revolves a single runner. The suction pipe enters the casing at the centre and the discharge pipe at the edge.

The working of the pump is as follows. Before pumping is begun, the casing must be filled with water to prime it, because the revolving runner does not create a sufficient vacuum to allow the atmospheric pressure on the water in the well to force water into the casing. When the pump is primed and the runner is started revolving, the water is forced to the outer rim of the casing and escapes through the discharge pipe; this leaves a vacuum at the centre of the casing and the atmospheric pressure on the water in the well forces water up the suction pipe into the casing. This water in turn is driven into the discharge pipe and more is forced up from the well, and so on; the process continues as long as the runner revolves.

The action of the pump may be illustrated as follows. If an iron nut, tied to a string, is revolved in a circle and the string let go, the nut flies off at a tangent to the circle. Similarly, the water is made to revolve in the casing and when it comes opposite the discharge pipe moves into it with the velocity of the runner but in a direction tangent to the circle.

This is the reason the discharge pipe is placed at a tangent to the circle of the casing.

The primer shown above the pump in the figure is used to prime the pump by hand. It is fitted to the suction pipe at the point the latter enters the casing. The primer is simply a small air pump operated by hand. There is a check valve on the discharge pipe which prevents air from entering the casing from that direction; therefore when the primer is operated, air is drawn out of the casing and suction pipe, and the atmospheric pressure on the water in the well forces water into them. In one form of pump in which the shaft is vertical and the runner and casing horizontal, the necessity for priming is obviated, by placing the runner and casing below the water level.

Centrifugal pumps are in use in all kinds of pumping and especially for irrigation and drainage. They have a large water way and no valves, and thus are able to pass stones, twigs, leaves, etc., which would clog an ordinary pump.

The air-lift pump. Another form of pump which has neither valves nor plunger is the

air-lift pump. The drawing in Fig. 45 shows the general arrangement of the Saunders air-lift pump. Above the ground there is the air

W. L. SAUNDERS
Air Lift Pump

No. 597,023.

Patented Jan. 11, 1898.

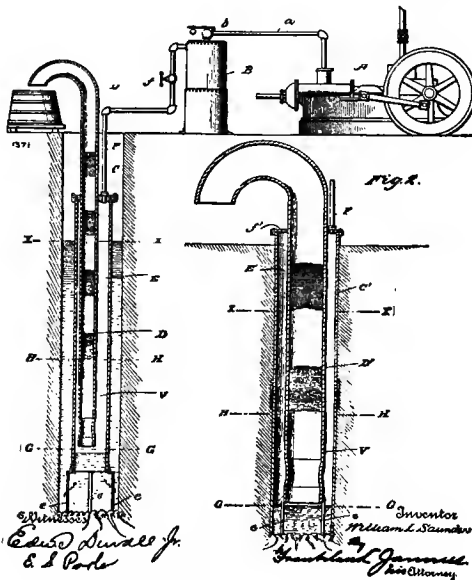

Fig. 45. Air-lift pump.

compressor A and the air-storage tank B. In the well is a double pipe, the outer one is the compressed air pipe and the inner one the dis-

charge pipe. This double pipe must be lowered into the well until at least half of it is below the water level when the pump is working at its normal rate. That is, there must be at least fifty per cent submergence when the pump is running. The reason for this will be seen later.

The action of the pump is as follows. The compressor A is run by some form of engine. It compresses air in the tank B, and when the tap "f" is opened, compressed air from the tank enters the outer pipe in the well and forces the water down from the level xx to the level GG. At the beginning there is a large column of water in the discharge pipe which must be forced out. After this is done the pump assumes its regular operation. It is as follows. Compressed air escapes into the discharge pipe; this decreases the pressure in the outer pipe and water rises above the level GG and enters the discharge pipe. The compressor restores the former air pressure and more air escapes into the discharge pipe and drives up the water above it. The pressure is thus again reduced and water again enters the discharge pipe, etc.

At one instant water enters the discharge pipe, the next instant air, etc. On the inside of the discharge pipe the condition is that shown in the figure; the column which is moving up the pipe is made up of alternate layers of water and air.

Now let us see why the water and air move up the discharge pipe. We can show this as follows:

In Fig. 46, I is a U-shaped tube containing water. The water level is the same in each arm because each column exerts the same pressure. If now we fill one arm with an oil which is lighter

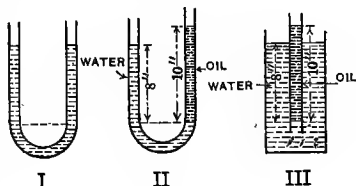

Fig. 46.

than water, the water will balance a higher column of oil. For example, if the oil is eight-tenths as heavy as water, a column of water eight inches high will balance a column of oil ten inches high, as is shown in II. This is also shown in III, where an outer column of water eight inches high is balancing an inner column of oil ten inches high.

This is precisely what happens in an air-lift pump. The heavier column is the water in the well from xx to GG. The lighter column is that in the discharge pipe; it is part water and part air, and since air is very much lighter than water, the average weight per cubic foot is very much less than that of water, and therefore it takes a greater length of column to balance the column of water in the well. Or, stating it another way, if there is enough air with the water in the discharge pipe to make its pressure per square inch at the level GG, less than the pressure of the water column in the well per square inch at the level GG, the water column in the well will force the air and water out of the discharge pipe. This explains why the submergence must be at least fifty per cent; that is, why the length of the pipe xx to GG must be at least one-half the length from the top of the discharge pipe to GG; because the water column in the well must have a sufficient length to make its pressure greater than that of the column of water and air in the discharge pipe.

Different methods of admitting the air to the

discharge pipe are shown by the drawings in Fig. 47. In 1 the air is carried down a branch pipe and admitted at the side. In 2 the air is admitted from a branch pipe through an annular ring which admits air to the discharge pipe equally on all sides. The system illus-

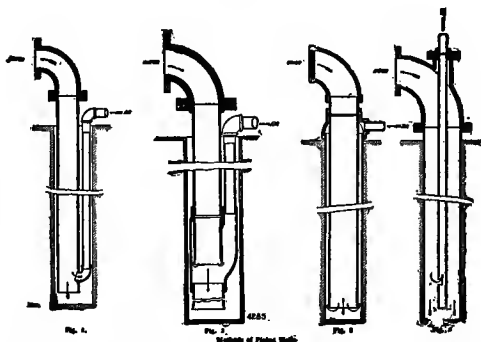

Fig. 47. Methods of admitting air to the discharge pipe.

trated in 3 is that described above. In 4 the air is carried down a central tube and admitted to the discharge pipe through a side vent.

The air-lift pump will lift water from a well of any depth and force it to practically any height, if the proper amount of submergence is secured.

The chain pump. The most primitive and unsanitary method of lifting water is by means

of a bucket attached to a pole or chain, because the top of the well is usually open to contamination by dust, disease germs, leaves, etc. To this class belongs the "Old Oaken Bucket." Like a great many other old and picturesque things, it is more poetic than commendable.

The chain pump (Fig. 48) is related to this

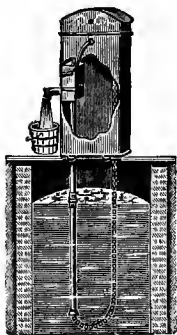

Fig. 48. Chain pump.

type of water-lifting appliance in that it lifts water in buckets. It is an immense improvement on the well-sweep and bucket, however, and is as sanitary as any pump, if the top is kept closed. In fact the buckets moving down into the water carry air with them, which has a beneficial effect on the water if the

air in the well is kept free from dust and its attendant disease germs.

The chain pump is different in principle from the pumps described above, in that it does not make use of any of the properties of air, since it raises water by a simple straight lift.

In the pump shown in Fig. 48 a series of

buckets which just fit the pipe are fastened together in a chain and, as they move up the pipe, each bucket lifts and carries up the water above it and delivers it at the spout.

CHAPTER IX

RUNNING WATER

GRAVITY SUPPLY AND THE ELEVATED TANK

THERE are three methods of supplying the home with running water: first, by gravity, from a well or spring on higher ground; second, by gravity from an elevated tank; third, by means of a pneumatic tank. For those who are so fortunate as to live near an elevated spring, the simplest and cheapest method of obtaining running water is to pipe it from the spring to the house, stables and fields. This method is only possible in a hilly or rolling country and even there the spring may be too low or too far away. In many cases, however, an artificial spring may be made by sinking a well on a hillside. If the water level in this well is above the house and barns, water will flow to them by gravity. This is a convenient and inexpensive arrangement since the water is brought to the

house and barns without pumping; for a fuller description, see page 61 above.

Elevated tank. The commonest form of

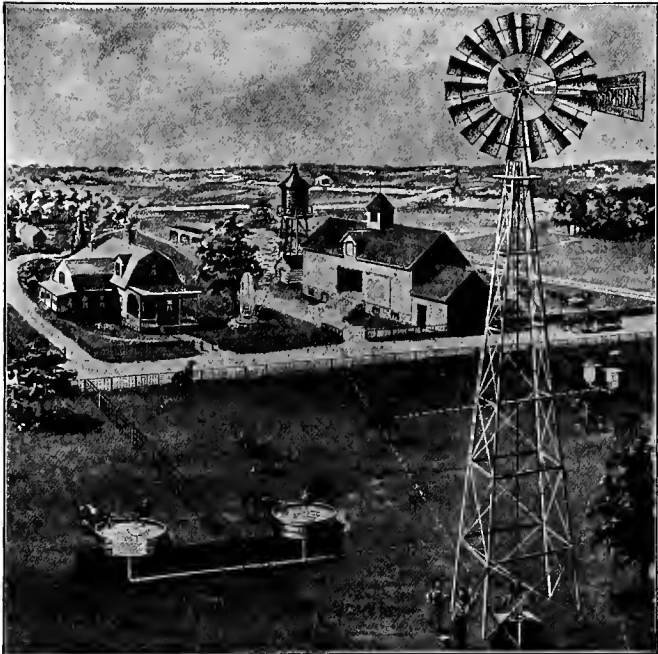

Fig. 49. General view of the elevated tank system of water supply.

gravity supply is by means of an elevated tank, into which water is pumped, and from which it runs to the house, stables and fields. A general view of such a system of water supply is

given in Fig. 49. The tank is on a special tower; the water is pumped into it by a windmill and pump placed over the well. Branches from the supply pipe deliver water to the stable, the house, and to watering troughs in the fields. Float valves in the watering troughs keep the water at a fixed level.

There are three points to be settled regarding a storage tank, namely, its size, its elevation and its location. The first is its size, and that depends upon the amount of water needed and upon the kind of power used for pumping. If the water is pumped by windmill it is advisable to have a tank that will hold at least three days' supply, to tide over a time when the wind is not blowing. If the water is pumped by hand or by an engine which is independent of the weather, a tank holding a supply for one day is sufficient. The table below is made up from figures supplied by manufacturers of water supply equipment.

WATER NEEDED PER DAY IN U. S. GALLONS

For each member of family for kitchen and	
washing	10

For each member of the family for all purposes, including bath and water closet .	25
Each horse	10
Each cow	10
Each pig	2
Each sheep	1

For example, on an average dairy farm of 100 acres, with a family of 6 and with stock consisting of 25 cows, 5 horses, 12 hogs and 15 sheep, the amount needed each day would be: family, for all purposes, 150 gals., cattle 250 gals., horses 50 gals., hogs 24 gals., sheep 15 gals. Total—489 gallons, say, 500 gallons.

If then, the pumping is to be done with an engine independent of the weather, a 500-gallon tank will be large enough. If the pumping is to be done by windmill, however, it is advisable to have a tank to hold a supply for three days, or 1500 gallons.

Dimensions of tank. If we wish to build a tank to hold a certain number of gallons of water, we must know its dimensions. We find the dimensions of a tank as follows. We know that a U. S. gallon holds 231 cubic inches and that a

cubic foot is 1728 cubic inches; therefore if we divide 1728 by 231 we find that there are nearly 7.5 gallons in one cubic foot. Let us suppose we are trying to find the dimensions of a tank which will hold 500 gallons. If we divide 500 gallons by 7.5, the number of gallons in a cubic foot, we find that a 500 gallon tank must hold $66\frac{2}{3}$ cubic feet, or say, about 70 cubic feet. If the tank is to be rectangular, we find its volume in cubic feet by multiplying the inside length by the inside width and by the inside depth. A tank to hold about 70 cubic feet, then, could be: 5 feet long by 4 feet wide by $3\frac{1}{2}$ feet deep; or, 6 feet long by 4 feet wide by about 3 feet deep; or, 6 feet long by 5 feet wide by $2\frac{1}{3}$ feet deep, etc.

If we wish to know the dimensions of a 1500 gallon rectangular tank we proceed in the same way: dividing 1500 gallons by 7.5, the number of gallons in a cubic foot, we find that the tank must hold just 200 cubic feet; therefore its inside dimensions might be: 10 feet long by 5 feet wide by 4 feet deep; or 10 feet long by 6 feet wide by $3\frac{1}{3}$ feet deep; etc.

To find the volume of a cylindrical tank, the

inside diameter is squared and divided by four; then this is multiplied by twenty-two sevenths and by the inside depth; for example, a cylindrical tank 6 feet in diameter and 7 feet deep will hold $\frac{6 \times 6}{4} \times \frac{22}{7} \times 7 = 198$ cubic feet.

If we wish to find the dimensions of a tank which will hold 500 gallons or about 70 cubic feet, we may calculate the volume using different diameters and depths until we strike one near 70 cubic feet; or we may decide on a certain diameter and calculate the correct depth; or decide on a certain depth and calculate the correct diameter. For example, if we decide to have the diameter 5 feet, we calculate the depth as follows. Let D represent the depth, then: $\frac{5 \times 5}{4} \times \frac{22}{7} \times D = 70$ cubic feet; or $\frac{275D}{14} = 70$; or $D = \frac{70 \times 14}{275} = 3.56$; that is, the depth D is a little over $3\frac{1}{2}$ feet. Similarly, if the diameter is taken as 6 feet, the depth works out to be 2.47 feet or a little less than $2\frac{1}{2}$ feet. In a similar manner, we may calculate the dimensions of a cylindrical tank large enough to hold 1500 gallons or 200 cubic feet, and of tanks of any volume we choose.

In each case discussed above we have found

the exact inside depth required to hold the quantity of water stated. This is the depth from the overflow pipe to the bottom of the tank, and since the overflow pipe is placed four inches below the top of the tank, the actual depths will be four inches greater than those found above.

Weight of tank when full. In placing a tank in an elevated position, care must be taken to see that the support is strong enough to hold it. This is especially true when the tank is placed in the attic of the house. A U. S. gallon of water weighs $8\frac{1}{3}$ lbs.; therefore, a tank holding 500 gallons holds $500 \times 8\frac{1}{3} = 4166$ lbs. of water, or over 2 tons. The total weight is this amount, plus the weight of the tank when empty. A 1500 gallon tank holds $1500 \times 8\frac{1}{3} = 12,500$ lbs. of water, or $6\frac{1}{4}$ tons.

The tank located in the attic or hay mow should, if possible, be placed over a strong partition and should be supported by a number of long, stout timbers running across the beams, in order to obtain as large a supporting area as possible. For this reason also, house tanks are usually made rectangular and shallow.

Elevation of tank. When the tank is at some

distance from the house it is usually placed at such a height that the bottom is ten feet above the highest water tap. This elevation secures a good flow of water at the upper taps. If the tank is just above the tap, as when it is in the attic, a less elevation will suffice, since the connecting pipe is short and therefore the friction in the pipe line is small.

Each foot of elevation gives a pressure of .434 lbs. per square inch at a water tap. This is calculated as follows. A cubic foot of water weighs $62\frac{1}{2}$ lbs. and there are 144 square inches in one square foot. The pressure on one square foot of water one foot deep is $62\frac{1}{2}$ lbs., and therefore the pressure on one square inch is $62\frac{1}{2}$ divided by 144, or .434 lbs.—that is, water one foot deep exerts a pressure of .434 lbs. on each square inch, and water standing 10 feet above a tap will exert a pressure of 4.34 lbs. per square inch at the tap.

Location of tank. The tank may be placed in the attic; in the hay mow; on a tower; or on high ground near the house and stables. The most difficult task in connection with an elevated tank, in northern latitudes, is to pre-

vent the water from freezing in winter. This difficulty is largely avoided if the tank is placed in the attic with the supply pipes along the inner walls of the house; or if it is placed in the hay loft, with the pumps in the stable and the supply pipe underground to the house.

The latter arrangement is generally used on farms in Canada and the northern part of the United States. The tank is placed in the hay mow, which is usually full of hay during the winter, and therefore the water in the tank is protected from frost. The pump and piping are placed in the cow or horse stable below, where the natural heat of the animals is sufficient to prevent freezing, and where the apparatus may be easily examined at any time, winter or summer.

If the windmill is the source of power, it is placed on the peak of the roof, which saves part of the expense of a windmill tower. If the water in the well is below suction distance (about twenty feet), a dry well may be dug below the stable floor, deep enough to bring the cylinder within suction distance of the water in the well; or the windmill and pump may be

placed over the well. In the latter case, the pump cylinder is lowered into the well, near to or under the water surface. In every case the piping from the tank to the house and to the well is placed underground. If the power is a gasoline or hot-air engine it is placed beside the pump in the stable, or in a house built over the well.

In warm climates the tank may be placed outside on the windmill tower or on a separate tower. This arrangement may also be used for a summer house where the water is needed only during the summer months. If it is used in cold climates the piping must be protected with three or four layers of insulating material boxed in. In very cold climates, a house is usually built to hold the tank, tower, engine and pump, and this is kept warm by a small fire kept burning continuously during the winter months.

The tank may be placed on a hill if there is one of sufficient height within reasonable distance of the house and barns. This is the best possible arrangement, because there is no expense for a tower and no danger of the tank's falling; also, if it is banked up with earth

and covered with a roof, and if the piping is placed underground, there is little danger from frost.

Tank supplied from the eaves. In another form of gravity supply a storage tank is placed in the house or barn, in an elevated position, but sufficiently low to allow the water to run directly from the eaves into the tank. This arrangement saves the labor of pumping. The chief obstacle to the introduction of this method is that the floors in the ordinary house are not strong enough to bear the weight of a large tank and a large tank is needed to hold sufficient water to supply the house from one rain shower to the next. In many cases two tanks are used, a small one elevated and a large one in the cellar to hold the overflow. In other cases, a medium-sized tank is used and the well force pump is connected to it, to furnish the supply when rain water fails.

Prices. To give the reader some idea of the cost of these tanks, the following retail cash prices are given. They are taken from the current price list of a large retail dealer.

ROUND 1½ IN. CYPRESS TANKS		ROUND GALVANIZED STEEL TANKS	
Gallons	Price	Gallons	Price
175.....	\$ 5.40	180.....	\$ 5.00
500.....	12.00	500.....	11.00
1000.....	20.00	1000.....	17.00
2000.....	28.00	2000.....	26.00

STEEL TOWERS

To hold a 1000-gallon tank, 20 feet high, \$40.00.

To hold a 2500-gallon tank, 20 feet high, \$64.00.

Towers 40 feet high cost about twice these amounts.

Those who are thinking of installing a storage tank are advised to write for further particulars to the large dealers, who will furnish catalogues and price lists.

CHAPTER X

RUNNING WATER

THE PNEUMATIC TANK

THE pneumatic-tank system of supplying running water has been on the market for the last ten or fifteen years, and has met with great favor. It is the best system, so far devised, for supplying running water to homes which are out of reach of a city water system and which have not a natural gravity supply.

The outfit consists of an air-tight steel tank, a force pump, and piping to connect well to pump, pump to tank, and tank to house pipes. The tank is fitted with a water glass to show the height of the water, and a pressure gauge to indicate the air pressure. The tank may be placed in the cellar of the house; in the stables; or it may be buried in the ground. The essential thing is, that it should be protected from frost. The pump may be placed at any conven-

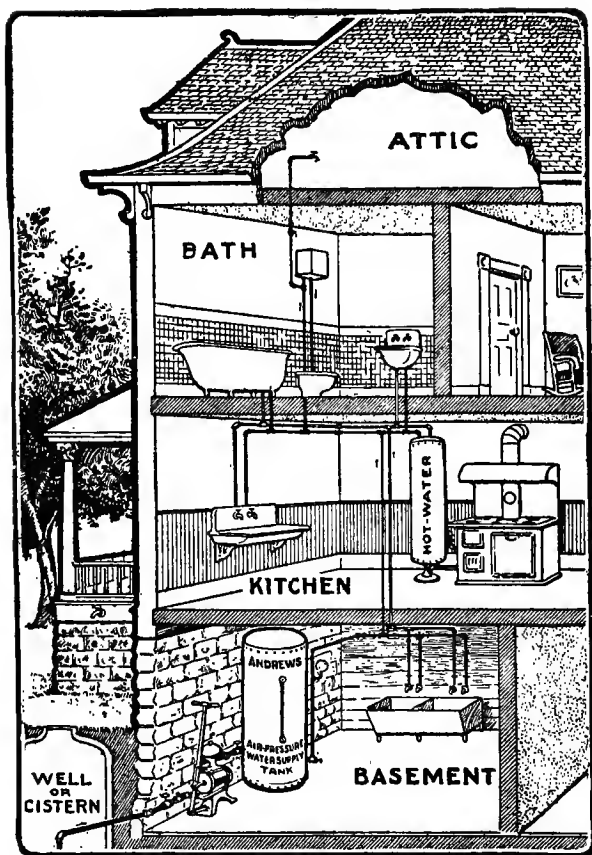

Fig. 50. Pneumatic tank water-supply system.

ient point: at the well, in the stables, or in the cellar. It may be operated by any form of power: hand power, windmill, gasoline engine,

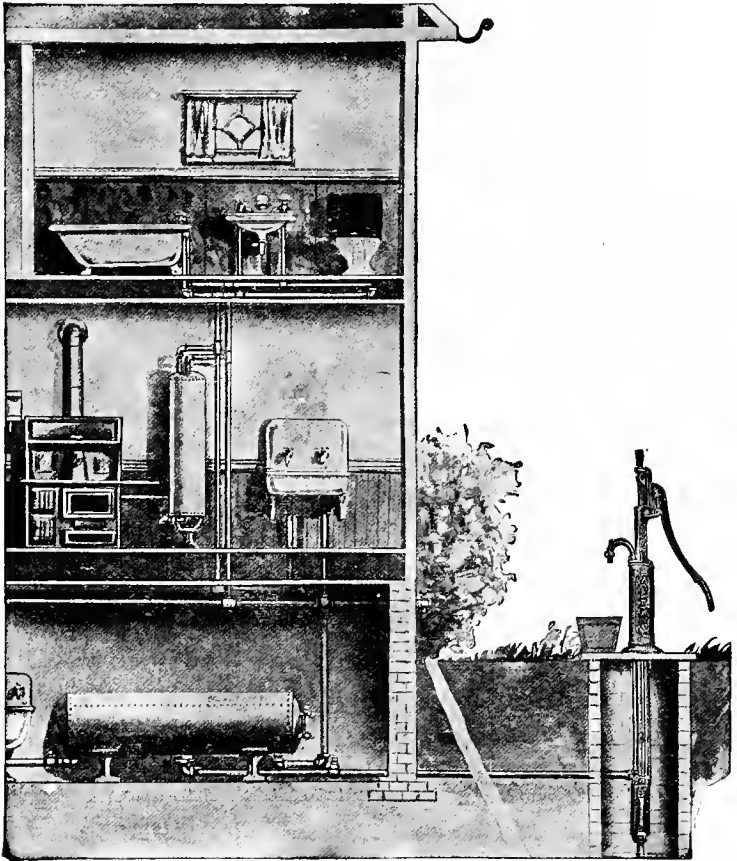

Fig. 51. Pneumatic tank water-supply system.

hot-air engine, electric motor, etc. These different sources of power are described in later chapters.

How the pneumatic system works. The working of the system (see Fig. 53) is as follows. The pump draws water from a well, cistern or other source and forces it into the air-



Fig. 52. Pneumatic tank.

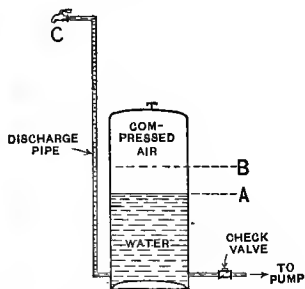

Fig. 53. Sectional view of pneumatic tank.

tight steel tank T. The air in the tank is thus compressed to smaller volume and exerts a greater pressure down on the water. This air pressure forces the water out of the tank, up through the discharge pipe and out at the tap C in the upper part of the house.

The property of air used in the pneumatic tank is that expressed by Boyle's Law explained in Chapter VI, namely: "The volume of a gas

varies inversely as the pressure upon it," and "the pressure exerted by a gas is equal to that exerted upon it." To understand how the pressure of the air in the tank varies as its volume is changed, we must understand the difference between *absolute* pressure and *gauge* pressure. Absolute pressure is the total pressure and gauge pressure is the pressure above atmospheric pressure. In the case of gases the absolute pressure is always 15 lbs. greater than the corresponding gauge pressure. For example, if a tank is standing open, the air in it is at an absolute pressure of 15 lbs. per square inch, because all our atmosphere is at that pressure; but the gauge on the tank registers 0, that is, the gauge pressure is 0. We must remember further that when air is compressed to $\frac{1}{2}$, $\frac{1}{3}$, $\frac{1}{4}$, etc., of its first volume, it is its absolute pressure which is raised to 2, 3, 4, etc., times its first absolute pressure. For example, in the tank T, Fig. 53, if the tank is open at the beginning, it is full of air at an absolute pressure of one atmosphere, 15 lbs. per square inch. If, now, the tank is closed, and water is pumped in at the bottom until the tank is half full, as at A,

the air is compressed to one-half its volume, and it exerts an absolute back pressure of two atmospheres.

If the tank is filled with water until two-thirds full, as at B, the air is compressed to one-third the volume it had at first and it exerts an absolute back pressure of three atmospheres. Similarly, if the air is compressed to $\frac{1}{4}$, $\frac{1}{5}$, $\frac{1}{10}$, etc., of its first volume it will exert an absolute pressure of 4, 5, 10, etc., atmospheres.

The air outside the tank is at an absolute pressure of one atmosphere, 15 lbs. per square inch. When the air in the tank is compressed to one-half its volume, it exerts an absolute pressure of two atmospheres, 30 lbs. per square inch, but only 15 lbs. of this is available for lifting water, because, when a tap is opened to draw water, the atmosphere presses against the water in the tap with a force of 15 lbs. per square inch. Therefore, although the air in the tank is exerting a pressure of 30 lbs., there is only $30 - 15 = 15$ lbs. of it available for lifting water. Similarly, when the air in the tank is compressed to one-third its volume it exerts an absolute pressure of three atmospheres, 45 lbs.

per square inch, but all that we can make use of to lift water is 45 — 15, or 30 lbs. per square inch. In other words, we must always subtract 15 lbs. per square inch from the absolute pressure of the air in the tank, in order to find the pressure we have available to lift water.

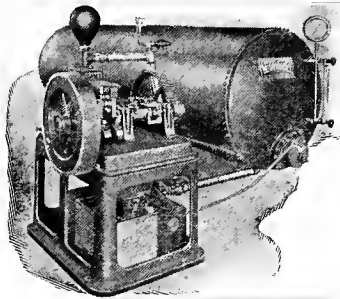

Fig. 54. Pneumatic tank operated by gasoline engine.

The gauge pressure, however, is the absolute pressure minus 15 lbs., therefore if the gauge registers 15, 30 or 50 lbs., etc., it means that we have 15, 30 or 50 lbs. pressure

per square inch available for lifting water.

The height the water is raised. If the air in the tank is compressed, each pound of pressure will lift water 2.3 feet. This is shown as follows. One cubic foot of water weighs 62.5 lbs.; therefore, water one foot deep exerts a pressure of 62.5 lbs. on one square foot or $\frac{62.5}{144} = .434$ lbs. per square inch. Stating this the other way round, .434 lbs. per square inch is the pressure exerted by water one foot deep.

Therefore, 1 lb. per square inch is the pressure exerted by water $\frac{1}{.434} = 2.3$ feet deep.

If the tank and pipe are both open to the air, the water in the pipe is at the same level as that in the tank. If now the tank is closed and water is pumped in until the air pressure indicated by the gauge is 1 lb. (that is, the air in the tank is at a pressure of 1 lb. above that outside), the water in the pipe will stand just 2.3 feet above that in the tank, because it takes a depth of 2.3 feet of water to exert a pressure of 1 lb. per square inch. If water is pumped in until the pressure of the air in the tank is 2 lbs., the water in the pipe will be $2.3 \times 2 = 4.6$ feet above that in the tank. Similarly, 10 lbs. pressure per square inch in the tank will lift water in the pipe $2.3 \times 10 = 23$ feet; 15 lbs. pressure in the tank will lift water $15 \times 2.3 = 34.5$ feet, 30 lbs. pressure in the tank will lift water $30 \times 2.3 = 69$ ft., etc.

Pressure of water at a tap. If the air pressure in the tank is, say, 15 lbs., as stated in the last paragraph, this will lift water in the pipe 34.5 feet above the water in the tank. If the highest tap on the second floor is, say, 20 feet

above the level of the water in the tank, the water pressure at the tap is equal to the pressure given by a depth of water of $34.5 - 20 = 14.5$ feet; or it is equal to the pressure that

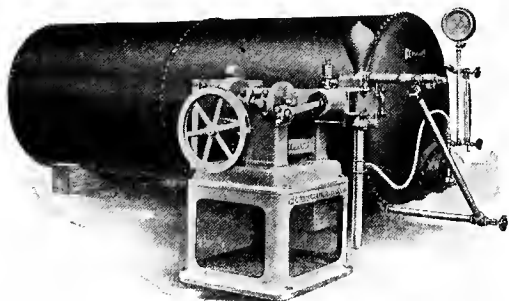

Fig. 55. Pneumatic tank with electrically driven pump.

would be given by an elevated tank in which the water stands 14.5 feet above the tap.

If the pressure in the tank is 30 lbs. per square inch, it will, as shown above, lift water in the pipe 69 feet above the water in the tank, or at a tap 20 feet above the water in the tank it will give a water pressure equal to that given by an elevated tank in which the water stands $69 - 20 = 49$ feet above the tap. If the pressure in the tank is 60 lbs. per square inch, it will lift water $60 \times 2.3 = 138$ feet in a supply pipe, or at a tap 20 feet above the water in the

tank, it will give a water pressure equal to that given by an elevated tank in which the water stands $138 - 20 = 118$ feet above the tap, etc. It is seen from this that by increasing the air pressure in a pneumatic tank on the ground, a water pressure may be produced equal to that given by any elevated tank.

Excess air pressure. As the water is forced out of the pneumatic tank, the air expands and therefore the air pressure decreases. In order to force all the water in the tank to



Fig. 56. Pneumatic tank operated by gasoline engine.

the fixtures; it is necessary to carry a certain amount of excess air pressure in the tank. Excess air pressure is the gauge pressure left when the last drop of water is being forced out of the tank. For the ordinary house it is advisable to have an excess pressure of 10 lbs., as this will lift the last part of the water $10 \times 2.3 = 23$

feet, or 3 feet above a tap which is 20 feet above the bottom of the tank.

A gauge pressure of 10 lbs. is an absolute pressure of $10 + 15 = 25$ lbs. If a tank has 10 lbs. gauge pressure or 25 lbs. absolute pressure when it is empty, it will have an absolute pressure of $25 \times 2 = 50$ lbs., when it is pumped half full of water, because, as we saw above, when the air is compressed to one-half its first volume, its absolute pressure is doubled. An absolute pressure of 50 lbs. is a gauge pressure of $50 - 15 = 35$ lbs.; therefore, a gauge pressure of 10 lbs. when the tank is empty, becomes a gauge pressure of 35 lbs. when the tank is half full of water. If the tank is filled two-thirds full of water, the air is compressed to one-third its first volume and the absolute pressure is trebled, or is $25 \times 3 = 75$ lbs. This is a gauge pressure of $75 - 15 = 60$ lbs.; that is, a gauge of 10 lbs. when the tank is empty, becomes a gauge pressure of 60 lbs. when the tank is two-thirds full of water.

An excess pressure of 10 lbs. is sufficient for an ordinary house; but if water must be delivered at a greater height, as in an office

building, the excess pressure must of course be increased.

The air is absorbed. From what has been said so far, it might be supposed that the air in the tank would last forever, and that it could be used over and over again. This is not quite true, however, because of a property of air which has not yet been mentioned. This property is—"Air is absorbed by water." All water in its natural state in rivers, lakes, etc., holds a certain amount of air absorbed in it. We realize that this is true, when we remember that fish live in water, and that they breathe by passing water through their gills where their blood is oxidized by the air absorbed in the water. The amount of air absorbed in water depends on the pressure of the air. A certain quantity is absorbed when the pressure is one atmosphere; twice this amount is absorbed at two atmospheres pressure; three times the amount at three atmospheres pressure, etc. For this reason, the air in the tank is gradually absorbed and passes out with the water; and the higher the air pressure used the more rapidly does the air disappear. To counter-

balance this absorption, a fresh supply of air must be pumped in from time to time. When air is to be pumped, it is well to remember two points: first, to do the pumping when the tank is nearly empty, because then the pressure is low and the work easy; second, to drive the plunger to the end of its stroke, because the first part of the stroke simply compresses the air until its pressure is equal to that of the air in the tank, and the last part of the stroke forces the air into the tank.

The size of the tank may be determined as was the size of the elevated tank in the last chapter. It must be remembered, however, that the tank is usually filled only two-thirds full of water, the other third being air. If a windmill is used to operate the force pump, a tank capable of holding three days' supply should be used. If the source of power is independent of the weather, a tank that will hold one day's supply is sufficient.

Advantages of the pneumatic system. This system of water supply has a number of advantages. First, the tank is on the ground; therefore there is no danger of its falling, and if it

should leak, the water does not flood the house. Second, it is usually placed in a cellar or underground, and thus the water is kept cool in summer and does not become too cold in winter; also, if the pipes are underground there is no danger of the water's freezing. Third, it is no trouble to secure ample pressure on the water at the highest fixture. Fourth, the tank being closed, the water cannot be contaminated by dust, insects, etc. Fifth, since the water is highly charged with air, organic impurities are rapidly oxidized and the water is purified. Sixth, the tank does not mar the landscape.

A modification of the pneumatic system has been placed on the market lately, known as the Perry system. In this system air is forced into an air-tight steel tank by means of a hand air pump or some form of power air compressor. The compressed air is led from the tank to the well and operates an automatic pump which is placed below the water level. As soon as a tap is opened in the house, the compressed air forces water from the pump through the house-supply pipe and out at the tap. The advantage claimed for this system is that the water sup-

plied to the tap is always water fresh from the well.

The cost. The price of the pneumatic tank outfit varies, of course, with the size of tank and the kind of power used. A small equipment, consisting of a 220-gallon tank (150 gallons of water), with hand pump and all fixtures except suction pipe and house pipe, may be had for sixty dollars. The first cost is greater than that of an elevated tank, but on the other hand the heavy steel pneumatic tank will outlast a number of elevated tanks.

CHAPTER XI

THE SIPHON—THE HYDROSTATIC PARADOX—THE KINETIC THEORY

IN Chapters VI to X we have studied the different types of pumps and the different systems of water supply in which they are used. Before going on to the study of the various appliances used to operate these pumps, we will devote a chapter to the siphon, the hydrostatic paradox, and the kinetic theory of gases, all of which have a bearing on the question of water supply.

The siphon (Fig. 57) is an appliance used to lift water over an elevation by means of atmospheric pressure. It may be so used when the outlet is below the level of the inlet, and when the elevation is not over from twenty to twenty-eight feet. It is an air-tight pipe in the shape of an inverted U, with one side longer than the other. The water is forced into the short side by atmospheric pressure and flows

out the long side. To start the siphon the air must be removed from the pipe by some means. One method of doing this is to fill the entire pipe with water, plug the ends, invert it, and place the short end in the water to be lifted. When the plugs are removed the water will flow in at the short end, up over the elevation and

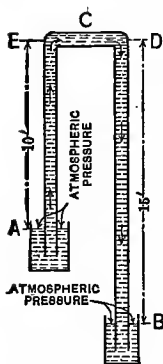

Fig. 57. The siphon.

out at the long end. Another method of removing the air, after the pipe is in place, is to place a force pump at either end and force water through the pipe. A better way is to attach a pump to the long end by means of a tee, close the long end, and pump until water comes; the water runs in at the short end, up over the bend, and down to the long end. If the pump is left in place, it may be used at any time to start the siphon, when the latter is stopped by the accumulation of air at the top of the bend.

The explanation of the working of the siphon is as follows. The pressure of the atmosphere will support a column of water thirty-four feet high if there is a vacuum above the water.

The siphon represented in Fig. 57 has the short arm ten feet above the water level A, and the long arm fifteen feet above the water level B. The pressure of the atmosphere is practically the same at A as at B, but if anything a trifle more at B than at A; the difference, however, is so small that the pressures may be considered equal. The atmospheric pressure on A holds up the column AE, 10 feet long, and that on B the column BD, 15 feet long. The column BD is heavier than AE; therefore the pressure on B has more to lift than the pressure on A, and as a result the pressure on A forces water over the elevation and out at B. Stating it in another way, the pressure to the right at the point C, is the atmosphere minus the weight of ten feet of water; the pressure to the left at C, is the atmosphere minus the weight of fifteen feet of water; therefore the pressure to the right is the greater, and the water moves to the right and out at the long end.

The siphon has many uses. It may be employed on the discharge pipe leading from a force pump into an elevated tank. It passes up over the edge of the tank and within about an

inch of the bottom; this saves all the trouble of making a connection at the bottom of the tank. The water is pumped into the tank through this pipe and drives out the air, and when a tap at the sink or elsewhere is opened, the water flows back over the edge of the tank and out at the tap.

It may also be used in a well on a hillside when the tap in the house or stables is below the water level in the well.

In many cases the spring and house are on opposite sides of a rise of ground. A siphon may then be used to carry the water over the rise, if the house tap is below the level of the spring, and if the top of the rise is not too high above the spring.

If a perfect vacuum could be kept in the siphon the atmosphere would lift water over a rise of thirty-four feet, but a perfect vacuum cannot be kept in the siphon because the air absorbed in the spring or well water escapes from the water, and gathers in the upper part of the siphon where the pressure on the water is slight. As soon as the top of the bend is filled

with air the siphon stops. The limit of the siphon in practice is about twenty-five feet.

The siphon should be absolutely air-tight, particularly at the bend; for this reason it is usually made of stout lead pipe from the spring or well up over the bend and down on the other side as far as the level of the spring or well. This pipe must be stout to resist the pressure of the atmosphere on the outside. With a lead-pipe siphon and a lift of about fifteen feet, the siphonage is seldom lost.

The hydrostatic paradox. The hydrostatic paradox is this: the pressure of water on any surface depends only on the *area* of the surface and the *height* of the water above it and not at all on the *quantity* of water above it. For example, if the lift bucket of a pump is raising water to a certain height, the lift (if we neglect friction) is the same with the same sized bucket whether the discharge pipe is 1 inch or 5 inches in diameter, although the quantity of water in the 5-inch pipe is 25 times as great as in the 1-inch pipe. Also if a tap is a certain distance below the level of the water in an elevated tank,

the pressure at the tap is the same, whether the tank holds 10 or 1000 gallons, although the quantity of water in the latter is 100 times that in the former. In a compression tank also, if the air pressure is say 30 lbs. per square inch, the pressure at a tap is the same no matter whether the area of the water in the tank, against which the air is pressing, is one square foot or a hundred square feet.

An illustration of the hydrostatic paradox is given in Fig. 58. In (1), (2) and (3) the

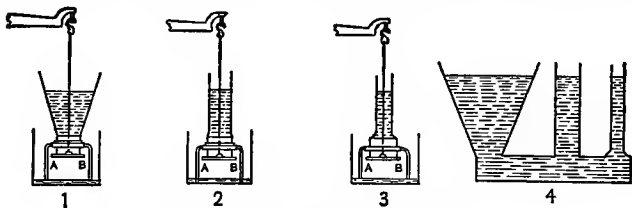

Fig. 58. The hydrostatic paradox.

base AB is the same in all, and the depth of water above AB is the same in all, but the volume of water is much greater in (1), than in (2), and in (2), than in (3). If the base is held on by weights placed on the pan of the balance, (not shown) it is found that the same weight is required in all three; that is, if a quarter-

pound weight is required to keep the water from running out at the base in (1), the same amount is required in (2) and (3), although the actual weights of water are very different. Therefore we say that the pressure water or any liquid exerts on a surface depends on the *area* of the surface and on the *depth* of water above the surface, but not at all on the *volume* of water above it. In (4) the same fact is illustrated. The water stands at the same level in all tubes no matter what may be their shape or volume.

The explanation of the hydrostatic paradox is: pressure in water is transmitted equally and undiminished in all directions at the same level. For example, if a pressure of 10 lbs. per square inch is exerted on a liquid at any point, this will exert a pressure of 10 lbs. on every square inch of the liquid at the same level. It is this law of liquid pressure that is made use of in all forms of the hydraulic press, the hydraulic elevator, the hydraulic lift, &c.

The kinetic theory of gases. We learned in Chapter VI that the atmosphere exerts a pressure of 15 lbs. on every square inch of surface it touches, and one method of illustrating

this was by means of the crushed syrup can,—when the air was removed from the can, the atmospheric pressure on the outside crumpled it up.

Let us look into this question of air pressure a little further. When the can is full of air it is not crumpled up, although the atmosphere is pressing on the outside; therefore the air in the can must exert a pressure outwards on the sides of the can, equal to that of the atmosphere inwards.

Let us suppose we had a syrup can in the shape of a cube, just one square foot on a side, with nothing in it but air. If we screw the cap on we have inside just one cubic foot or $1\frac{1}{4}$ ounces of air. The pressure of the atmosphere on the outside is 15 lbs. on every square inch of surface, and since the total surface is six square feet the total pressure on the outside is $6 \times 144 \times 15 = 12,960$ lbs. or over 6 tons. Since the can is not crumpled up the air inside must exert this pressure outwards, or $1\frac{1}{4}$ ounces of air exert a pressure outwards of over 6 tons.

This seems absolutely impossible, but nevertheless we know it to be a fact. If it is so, the

next natural question is: Why is it so? How can such a trifling amount of air exert such a great pressure? Scientists give the following explanation, which goes under the rather imposing name of The Kinetic Theory of Gases. It is: "Gases are made up of very small particles (molecules) which are in rapid motion; they are kept in motion by the heat they receive from their surroundings; when the gas cools the particles move more slowly and when it is heated they move more rapidly." This seems a rather far-fetched explanation, but it has been found that it explains everything about the behavior of gases which it could be expected to explain, and for this reason the theory is believed to be true.

How does it explain the pressure the small amount of air in the can exerts outwards? It does this as follows: there are millions of small air particles in every cubic inch of air; if they are in rapid motion they must strike against each other and against the inside of the can. Millions of these particles strike each square inch of the surface every second, and it is this bombardment that produces the pres-

sure outwards. This explains why a can, full of air, is not crumpled up by the pressure of the atmosphere on the outside. If the closed can is heated it bulges outwards, showing that the pressure inside is increased. The kinetic theory explains this as follows: since the air in the can is heated the particles are moving faster; therefore each one strikes harder, that is, they exert a greater pressure on the inner side of the can and it bulges out. Also if the closed can is cooled by pouring ice water on it it caves in, showing that the pressure inside is decreased. The kinetic theory explains this as follows: since the air in the can is cooled, the particles are moving more slowly and therefore are striking lighter blows, therefore the pressure they exert outwards is less and the pressure of the atmosphere forces the sides of the can in.

This theory also explains other facts we have observed above; for example, when the air in the air chamber of a pump is compressed to one-half its volume it exerts double the pressure on the water that it did at first. The explanation of this is that since there are twice as many

particles in every cubic inch of air, twice as many strike the surface of the water every second; that is, the air exerts twice the pressure on the water that it did before it was compressed. It also explains the fact that when air is compressed to one-third, one-quarter, etc., in volume, it exerts three, four, etc., times the pressure.

Also if air is pumped out of anything, we know that the pressure inside decreases; the explanation is that, since there are fewer particles in each cubic inch fewer strike each square inch per second, and therefore the pressure per square inch is less.

We learned in the chapter on pumps that when any volume of air is given a greater volume, it immediately expands to fill it. For example, if the bucket in a pump cylinder is lifted, the air below the bucket expands to fill the whole space. The Kinetic Theory explains this as follows. Since the particles are in motion there are millions moving towards the bucket at any instant; when the bucket is lifted they simply keep on moving towards it, and since all the particles are moving very rap-

idly and are striking each other many times a second, they are soon distributed evenly throughout the whole space.

The Kinetic Theory of Gases has been tested in many ways. It has led to the discovery of new facts regarding gases, and has furnished an explanation of all the facts it could be expected to explain, and for these reasons it is believed to be the true explanation of the pressure exerted by air and other gases.

CHAPTER XII

METHODS OF PUMPING

HAND POWER, HORSE POWER AND WINDMILLS

Hand power and horse power. If any considerable quantity of water is needed per day, the most expensive method of pumping it is by hand. A man can pump about 500 gallons of water an hour when the lift is 25 feet, and half this quantity when the lift is 50 feet. If we reckon a man's wages and board at \$1.50 a day, the cost of pumping the 500 gallons amounts to 15 cents each day or over \$50 a year. This is a pretty high water tax. Hand pumping is not only the most expensive method of obtaining a large supply of water, it is also the most arduous method. Anyone who has tried pumping water for an hour a day, every day of the year, will agree that it is hard, brutal work, and that it is work which should be done by some form of animal or mechanical power.

If a sweep or tread power is connected to a pump by means of a pump jack, water may be pumped by horse power. This is an improvement in comfort on hand pumping, and is also cheaper. A horse can pump about 4,000 gallons of water per hour on a lift of 25 feet, and if we take the cost of food and attendance for the horse at 35 cents a day, the cost of pumping the 4,000 gallons amounts to 3½ cents plus the cost of the man or boy attending the horse. This method of pumping is in common use, but it is not so cheap nor so convenient as other forms of power pumping, such as the windmill, hydraulic ram, gasoline engine, etc.

Windmills. One of the cheapest methods of pumping water is by means of a windmill (Fig. 59). There is no expense for fuel, and the only outlay is for oil and a small amount for attendance. The windmill is best suited to work which may be done intermittently and which requires only a small amount of power. The 12 and 16 foot power mills are used for such work as grinding grain, sawing wood, etc., but those in most common use are the 6 and 8 foot mills for pumping water.

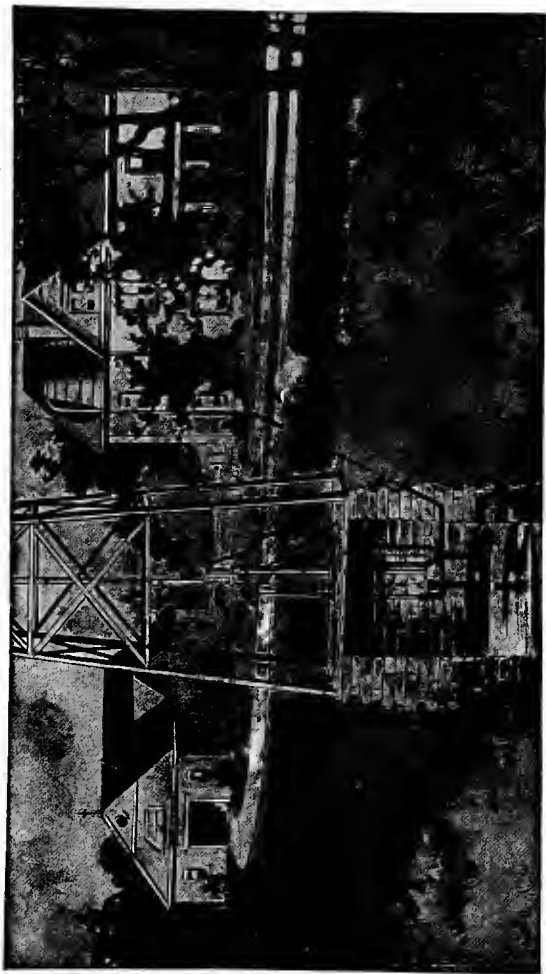

Fig. 59. Windmill pumping water into elevated tank.

The wind wheel. The windmill wheel is made of radial sails set at an angle to the plane of the wheel's motion. The wind strikes these sails and drives them sideways; this causes the wheel to revolve, and the rotary motion is turned into a reciprocating or up-and-down motion, by means of a crank, pitman and rocker arm at the other end of the axis of the wheel.

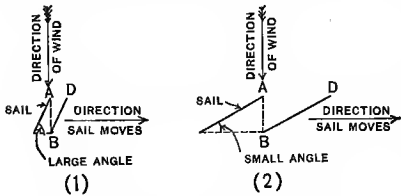

Fig. 60. Speed of windmill.

The pitman is attached to the pump plunger. The pitman gives the plunger an up-and-down motion which pumps water, and thus the windmill turns the energy of the wind into useful work. The speed of the wheel depends on the angle of the sails to the plane of the wheel; if the angle is great the speed is slow, if the angle is small the speed is great. The reason for this is shown in Fig. 60. In (1) the angle of the sail to the plane of the wheel's motion is large, and while the wind moves from A to B the wheel moves only from A to D; therefore

the wheel revolves slowly. In (2) the angle of the sail to the plane of the wheel is small and while the wind moves from A to B the wheel moves from A to D; therefore the wheel revolves rapidly. It will be noticed that in (2) the wheel travels much farther than it does in (1) although the wind travels the same distance in each case. That is, with the sails at a small angle as in (2) the speed of the wheel is greater than when the sails are at a large angle as in (1).

Wooden windmills are made with long narrow, wooden sails set at a large angle to the plane of the wheel, and therefore wooden wheels are slow-moving wheels. In mills of this class the pitman is usually connected directly to the crank on the end of the wheel axle, and therefore the pump piston makes one complete stroke for every revolution of the wheel. Steel windmills are made with broad curved sails of sheet steel, set at a small angle to the direction of the wheel's motion. They are therefore much faster than the wooden windmills, and when used for pumping, the wheel is

usually back-geared, so that it makes three or four revolutions for one complete stroke of the pump piston.

Power of the windmill. The pressure that the wind exerts on a square foot of surface varies as the square of the velocity of the wind. That is, if the velocity of the wind is doubled, the pressure it exerts on every square foot is four times as great. If the velocity is trebled, the pressure is nine times as great, etc. The pressure of the wind per square foot, according to experiments made at the Eiffel Tower, is expressed by the formula: $P = .003V^2$, where "P" is the pressure of the wind in lbs. per square foot and "V" is the velocity in miles per hour. For example, if the velocity is one mile an hour the pressure is equal to .003 pounds per square foot. If the velocity is twenty miles per hour the pressure is $P = .003 \times 400 = 1.2$ pounds per square foot, etc.

The pressure of the wind also depends on the weight of the air per cubic foot, and for this reason a wind with a certain velocity exerts a greater pressure in winter than it does in summer, because in winter the air is

colder and therefore denser, that is, it weighs more per cubic foot, and therefore, at the same velocity, a greater weight of air strikes the mill each minute in winter than in summer. This accounts for the well-known fact that a windmill does better work in winter than in summer, with the wind at the same velocity.

The power of the windmill is the amount of work it can do in a certain time. It depends not only on the pressure of the wind but also on the amount of air that passes through the wheel in a certain time. Therefore the power of the windmill varies as the *cube* of the velocity of the wind. For example, if a mill does a certain amount of work per hour in a ten-mile wind, it will do eight times that amount of work if the velocity of the wind is twice as great, or twenty miles per hour. The reason for this is as follows. Since the power of the windmill depends on the pressure of the wind and also upon the amount of wind which passes through the wheel, when the velocity is doubled the *pressure* is *four* times as great, and at the same time the *amount* of wind which passes through the wheel in a given

time is *twice* as great. Therefore the power or work done, is four times two, or eight times as much. That is, the power of a windmill varies as the cube of the velocity of the wind. This explains why the work done by a windmill increases so rapidly as the velocity of the wind rises.

Windmill governor. For the protection of windmills from damage by high winds, they are made self-governing. This is accomplished as follows. The wheel is kept facing the wind by a vane or tail placed at right angles to the plane of the wheel. The wheel is set a little to one side of the windmill head, so that when the wind is blowing, the wheel tends to swing around parallel to the tail. It is held in place by a governor, which is usually a spring or weighted lever so adjusted that when the wind reaches a dangerous velocity the wheel is allowed to swing parallel to the tail, and thus only the edge of the wheel is exposed to the force of the wind. When the wind decreases in velocity the governor swings the wheel back into the wind again. The governor can be set

for a wind of any velocity by adjusting the spring screw or lever weight.

Regulators. Various forms of regulators are used to stop the windmill when the tank is full and to allow it to start again when the water level has fallen to a certain point. In all forms of regulators, a wire is run from the governor to the regulator through the windmill head. The wire is attached to the governor in such a manner that when it is pulled down the wheel is pulled around parallel to the tail and stops working. When the wire is released, the governor swings the wheel into the wind again. The regulators differ only in the manner in which this wire is pulled down and released. One form is a hand reefing-gear. The wire is wound up on a drum by means of a crank arm and toothed gear. This pulls the wire down and throws the wheel out of the wind; when the wire is allowed to unwind, the governor swings the wheel into the wind again.

The best kind of regulator is one which is automatic in its action; it automatically stops

the windmill when the tank is full, and allows it to run again when the water level falls to a certain point. The majority of automatic regulators are worked by means of a wooden float placed in the tank, and connected to the regulator by means of wire and one or more rocker

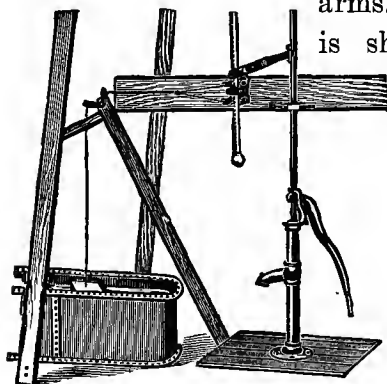

Fig. 61. Windmill regulator.

arms. This connection is shown in Fig. 61.

The regulator is connected to the pump rod by means of an arm which moves up and down with the rod all the time the windmill is running.

The wire from the governor is attached to the vertical notched bar as in Figs. 61 and 63 or to a notched wheel as in Fig. 62. When the water in the tank reaches a certain height, the float releases a dog which throws the regulator into gear. The motion of the arm attached to the pump rod pulls down the notched bar or turns the notched wheel, and these in

turn pull down the wire attached to the governor. This draws the wheel out of the wind, and the pumping stops. When the water level is lowered five or six inches the float lifts the

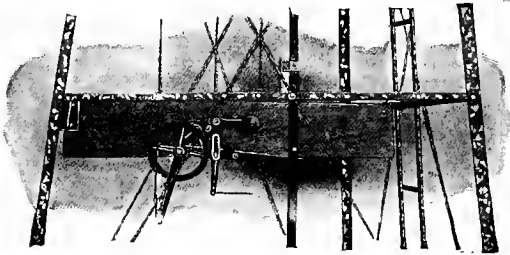

Fig. 62. Windmill regulator.

dog and releases the notched bar and wire. The governor then lifts bar and wire, throws the wheel into the wind, and the pumping begins again.

The automatic regulators shown in Figs. 61 to 65 are all worked by an arm attached to the pump rod, and are thrown in and out of gear by means of a float in the tank. They work equally well whether

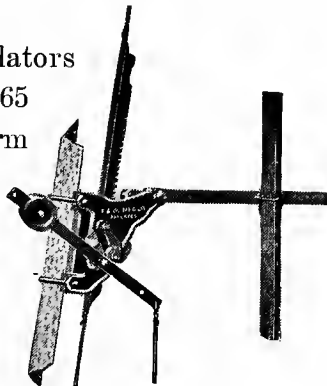

Fig. 63. Windmill regulator.

the tank is on the ground or in an elevated position.

A regulator of a different type is illustrated in Fig. 66. The float valve, Fig. 67, is placed in the tank on the top of the supply pipe, and when the water in the tank reaches a certain height

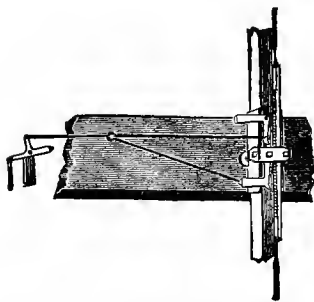

Fig. 64. Windmill regulator.

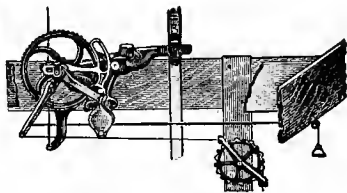

Fig. 65. Windmill regulator.

the valve closes the top of the supply pipe. As the windmill continues to pump, it forces water into the hydraulic cylinder, shown in Fig. 66. The water forces the cylinder down and the wire which is attached to the cylinder is drawn down and pulls the wheel out of the wind. When the level of the water in the tank falls to a certain point, the float valve opens and releases the pressure on the hydraulic cylinder. The wheel

governor then lifts the wire and cylinder and swings the wheel into the wind again. The complete regulator is shown in Fig. 72 below.

Towers. The windmill is placed on a tower to elevate it above any trees or buildings which might obstruct the wind. The general rule is to place the bottom of the wheel ten feet above any obstruction within six hundred feet of the mill. One method of doing this is to place the mill on the roof of the barn or stable. If the roof is

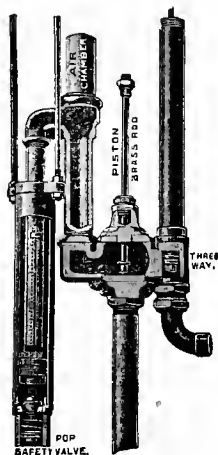

Fig. 66. Hydraulic cylinder.

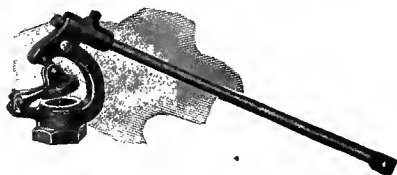

Fig. 67. Float valve.

strong enough, the tower is fastened to it. To do this, a squared timber is sawed lengthwise, the slant of the cut being the same as the slant of the roof; this timber should be long enough to take in five or six roof beams. The spread of the base of the tower is then

measured and each half timber is placed in the correct position on each side of the peak of the roof; then each is bolted to a four by four timber on the under side of the roof beams. This makes a good foundation; but if greater security is desired, the tower may be braced from the hayloft floor, by four by four timbers and by three-quarter inch rods bolted under the floor beams and above the timber on the under side of the roof, one timber and one rod being placed under each corner of the tower. In some cases the tower is brought down to the hayloft floor and fastened to it. The foundation then may consist of two pairs of four by four timbers; one timber of each pair being laid across the beams above the floor, the other below, and the two bolted securely together.

Towers were formerly made of wood, but good timber is scarce and costly, and as a result modern towers are made of galvanized steel. The chief points to be secured in a tower are strength and good anchorage. The advice of the manufacturers should be secured on these points, as they are careful to design each tower for the circumstances and service required. If

the tower is placed on the ground, the anchor posts are set in five or six feet and a cross-piece or anchor plate is fastened to the bottom of each, to prevent its being shoved into the ground or pulled out. To make sure that the posts will not be shoved into the ground, it is necessary to have a good foundation; this may be secured by placing flat stones or planks under each cross-piece or anchor plate. To make sure that the posts will not be pulled out, the cross-pieces should be loaded with heavy boulders; a good way to do this is to place timbers across each cross-piece and load the timbers with boulders. If towers buckle at all, they usually buckle in at the point the post leaves the ground; to brace this point a large boulder, or a stout timber five or six feet long, should be placed against each post on the inside, just beneath the surface, and backed with well tamped earth. If the tower is to hold a tank, each post should be imbedded in a concrete pier and a

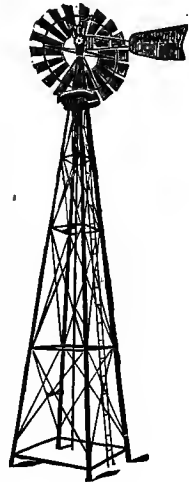

Fig. 68.

flat iron plate should be fastened securely to each post at the bottom of the pier and another at the top of the pier.

In order that the wheel may be examined and oiled, a ladder is placed on one side of the tower and a platform at the top. The tower and wheel should be examined from time to time to see that all nuts are tight.

Windmill and trough. In many cases a windmill is placed in a pasture to supply water to the stock, by pumping into a trough. In such cases the overflow pipe should carry the water a good distance from the trough, to avoid a mud puddle from which the water may soak back into the well; or a float valve and regulator, such as that shown in Figs. 66 and 67, may be used to stop the windmill when the tank is full and allow it to run again when the water level falls to a certain point. It is a bad practice to let the water run back into the well from the trough, because it is open to contamination of all kinds while in the trough.

Windmill and storage tank. The windmill is more generally used to pump water into an elevated tank or into a pneumatic tank. When

used in connection with an elevated tank, the tank is placed on a tower, in the hayloft, in the attic of the house, or on elevated ground. Fig. 69 shows the tank on the windmill tower. This arrangement is commonly used for summer homes where the water is not used in winter time, and in the southern part of the country where there is no danger of the water's freezing. It has the disadvantage, however, that the water becomes warm in summer.

In the northern part of the country the tank is usually placed in the loft over the stable or in the attic of the house. In one arrangement of this kind a closed steel tank of about thirty

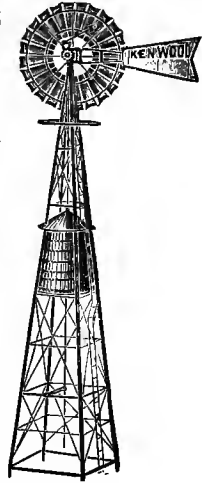

Fig. 69.

gallons capacity is placed in the house, and all the water is pumped through this tank, to a large storage tank in the hayloft above the stables. By this means the water in the house tank, from which the house supply is piped, is always the fresh water.

With the elevated tank in the stable loft the

windmill is usually placed above the peak of the roof. The pump is placed in the stable below, with a suction pipe running to the well, river or lake outside. With this arrangement the pump is easy to get at in winter and there is no danger of its freezing. If the water in the well, river or lake is below suction distance, a dry well may be made beneath the stable floor deep enough to bring the cylinder within suction distance of the water. If this is not feasible, the pump and windmill must be placed outside over the well or near the river or lake. If placed over the well, the pump cylinder is usually lowered into the water; if placed near the river or lake, the pump is placed in a dry well to protect it from frost. The suction pipe and the supply pipe to the tank are placed about

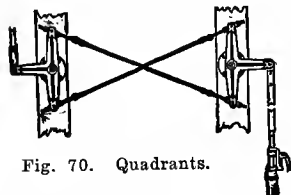

Fig. 70. Quadrants.

four feet underground for the same reason. In some cases the windmill is used to work a pump some distance away by means of the windmill quadrants shown in Fig. 70.

The proper plumbing between the pump and

elevated tank is shown in Fig. 71. The air chamber relieves the pump from sudden strains; the check valve holds the water when it is pumped; the union and gate valves allow repairs to be made in the piping to the pump without emptying the tank; the supply pipe also acts as part of the discharge pipe. The method of connecting it to the bottom of the tank with lock nuts is also shown. This pipe might also be passed over the edge of the tank and down to within an inch or two of the bottom. With this arrangement it is not necessary to make a hole in the bottom of the tank, for the water drawn off through the discharge pipe siphons back over the edge of the tank.

The windmill and pneumatic tank. The arrangement of the windmill in

connection with a pneumatic tank is shown in Fig. 72. The windmill is fitted with a hydraulic

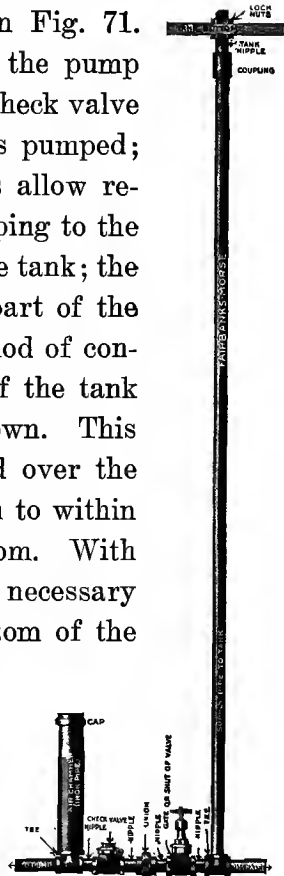

Fig. 71. Piping from pump to tank.

cylinder connected to an automatic regulator. This stops the windmill when the pressure in the tank reaches a certain point, and allows it to

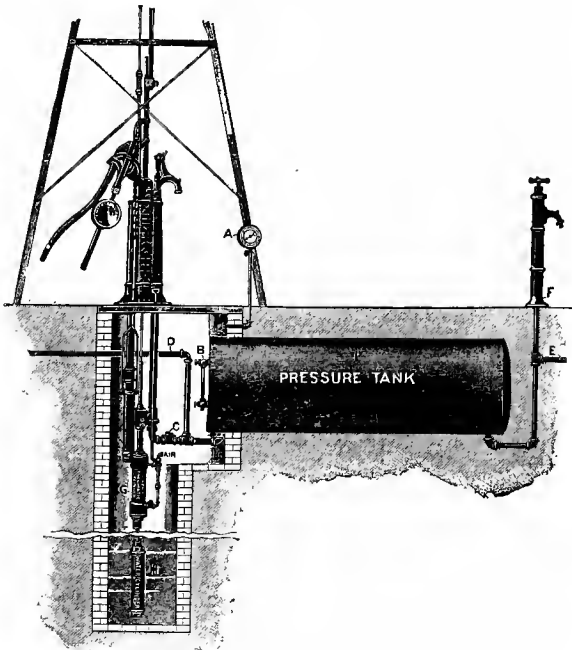

Fig. 72. Windmill operating a pneumatic tank.

run again when the pressure is reduced to a certain point. In addition the upper pump cylinder G is what is called a hydro-pneumatic cylinder. It is so arranged that by ad-

justing the handle shown just above the platform, either water or water and air is pumped into the pneumatic tank.

The pneumatic tank "i" may be placed in the ground as shown, or in the stable or cellar. It must be protected from frost. The water is pumped in at the bottom, and the compressed air is confined in the top of the tank. The compressed air forces the water to the house or stables through the discharge pipes E and D; the pressure gauge A registers the air pressure, and the water glass B shows the proportion of air and water in the tank. The hydrant F is used for a hose connection for watering the lawn, etc. Whether an elevated or pneumatic tank is used it should be large enough to hold at least three days' supply to allow for the time when the wind is not blowing.

Care of the windmill. It is not sufficient to buy a windmill and start it pumping. It must be cared for. If it is allowed to run without oil, and if the bolts and nuts are allowed to loosen, it will wear out in a short time. If the mill is used all day it should be oiled every day. If only for a few hours a day, once a week is

sufficient. If the mill is self oiling, it needs fresh oil only about once in three weeks. Every time the windmill is oiled, a wrench should be carried along to tighten any nuts that need it.

Prices. As in the case of all other water-supply equipment, the prices of windmills vary according to their size and quality. Windmills are advertised at the following prices: 4-foot steel \$13; 6-foot steel \$14; 8-foot steel \$18; 10-foot steel \$25; 8-foot wooden \$18; 10-foot wooden \$25; Towers, 40 feet high, 4 post, suitable for 8-foot mills, No. 1, weight 630 lbs., \$27; No. 2, 700 lbs., \$31; No. 3, 900 lbs. \$43; windmill force-pumps from \$7 up.

The windmill is an excellent servant; it requires no outlay for food or wages, and if given plenty of oil, and a little intelligent care, it will last many years and will do many dollars' worth of work each year.

CHAPTER XIII

METHODS OF PUMPING

THE HYDRAULIC RAM

Every foot-pound of work obtained from running water and from wind is clear gain. When coal, wood or oil is burned to drive an engine the work is done, but the fuel is gone forever. The work done is a gain, but against this must be placed so much fuel which cannot be used again. The work done by running water and by wind, however, is all gain, since the work done is a gain and the energy used would otherwise be wasted.

The hydraulic ram (Fig. 73) is one method of utilizing the energy of running water to pump water from a spring or brook into an elevated tank or into a pneumatic tank. It can be used where the running water has a fall of at least eighteen inches, although a fall of from three to ten feet gives better service. It will lift



Fig. 78. Hydraulic ram at work.

water from six to thirty feet for every foot of fall, according to the size and style of the ram; for example, if the fall from the brook to the ram is three feet, the ram will lift water from eighteen to ninety feet according to the size and style of ram.

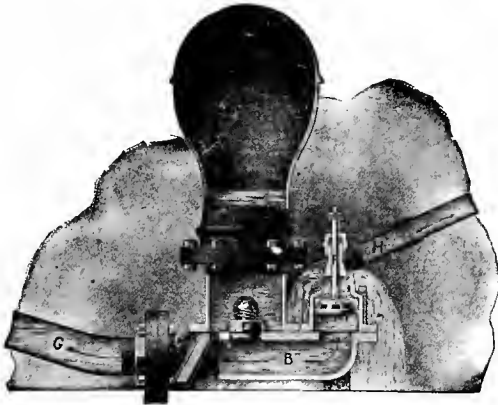

Fig. 74. Sectional view of Gould's standard ram.

How the ram works. The operation of the ram (Fig. 74) is as follows. The water from the brook or spring flows down the drive pipe G and out at the working valve F, as shown in Fig. 74. The rate of flow of the water rapidly increases and when it reaches a certain velocity the valve F is suddenly closed by the force of the water. The momentum of the water in

the drive pipe forces up the valve E and drives part of the water into the air chamber. The air in the chamber is compressed and thus exerts a back pressure on the water, which brings it to rest and starts it moving back up the drive pipe. This reaction or backward movement of the water closes the valve E and allows the valve F to open of its own weight. The water starts flowing down the drive pipe again, the valve F closes, and more water is forced into the air chamber, etc. This operation is repeated from twenty to two hundred times a minute according to the ratio of the fall to the height the water is pumped. The compressed air in the chamber forces water through the discharge pipe to the elevated tank, and from there the water flows to the house and stables by gravity.

At the base of the ram, just to the right of the flange of the drive pipe, is shown a small air valve C, called a sniffing valve. It serves to keep up the supply of air in the air chamber. Air is absorbed by water, and in time all the air in the chamber would be absorbed, and the chamber would become water-logged,

if a fresh supply were not admitted. The sniffing valve admits this fresh supply of air as follows: on the reaction or backward movement of the water a partial vacuum is created in the base of the ram B, and as a result, the pressure of the atmosphere forces a little air in through the sniffing valve; on the next forward rush of water, this air is carried into the air chamber.

In general the ram uses the energy of running water to force part of it to a higher level. If there were no loss of energy from friction in the pipes and valves, the fraction of the water raised would be the ratio of the fall to the lift; for example, if the fall were three feet and the lift thirty feet, three-thirtieths or one-tenth of the water would be lifted. There is loss of energy in friction, however, and only about one-fourteenth of the water is lifted when the ratio is one to ten; if the ratio is one to five, only one-seventh is lifted and similarly for other ratios, the amount lifted being always somewhat smaller than the theoretical amount.

In Fig. 75 is shown a sectional view of the Niagara hydraulic engine, a very efficient ram.

The water enters through the drive pipe A and flows out through the working valve 13. At a certain velocity the force of the water closes the valve 13 and the momentum of the water in the drive pipe drives a part of the water into the

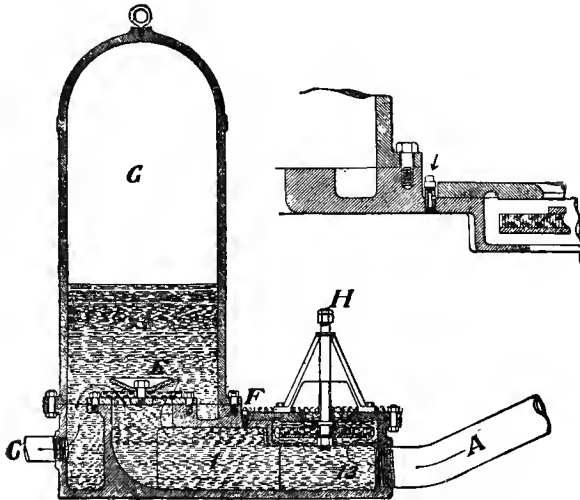

Fig. 75. Sectional view of Niagara hydraulic engine.

air chamber G. The compressed air in this chamber stops the rush of water and starts the reaction; this closes the valve E and allows the valve 13 to open again; also on the reaction a little air is forced in through the sniffing valve F by the pressure of the atmosphere. The com-

pressed air in G keeps a steady flow of water moving through the discharge pipe C. The upper drawing gives a better view of the sniffing valve.

The rate of flow of water is regulated by the set nuts H at the top of the stem of the working valve. If more water is wanted, the nuts are unscrewed so that the valve has a longer motion and works more slowly. The water in the drive pipe then acquires a greater velocity before the valve closes, and therefore it has a greater momentum. As a result, more water is forced into the air chamber at each ramming motion; the air is compressed to a smaller volume, and therefore exerts a greater force and drives more water up through the delivery pipe.

If less water is wanted, the nuts are screwed down so that the valve works more rapidly on a shorter motion. The valve closes when the velocity of the water in the drive pipe is small; therefore the momentum of the water is small and less water is forced into the air chamber. The air in the chamber is not compressed so much and therefore a smaller quantity of water

is forced through the discharge pipe in the same time.

The double acting ram. Rams are made to force water from a spring into an elevated tank by means of the power of a neighboring river or brook, the water of which may not be

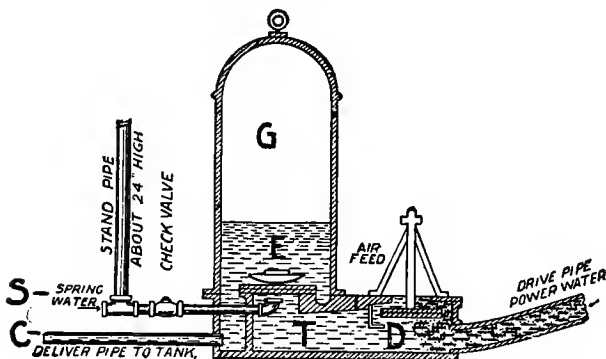

Fig. 76. Double-acting ram.

fit to drink. Fig. 76 is a sectional cut of the Niagara double-acting hydraulic engine. It is the same as the single-acting ram except that a supply pipe S from the spring is arranged to deliver water just below the valve E. The action of the ram is also the same as that of the single-acting ram, except that on the reaction the water enters the ram from the spring and

fills the base T. On the next ramming motion of the water from the brook, the spring water is forced into the air chamber and out through the delivery pipe C. The ram is so adjusted that there is an excess of spring water and some of it flows out through the working valve D. This is brought about by the stand pipe on the pipe from the spring. It is made high enough to give a rapid flow of spring water on the re-action. This excess of spring water prevents the river water from entering the air chamber and delivery pipe. The check valve on the spring-water pipe prevents the spring water from being driven back up the pipe by the ramming motion of the water in the drive pipe.

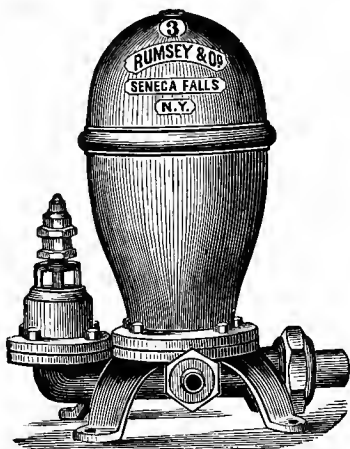

Fig. 77. A standard ram.

The equipment.

The drive pipe is made as straight as possible, to allow the water a free flow. Where a

bend must be made, as at the point it enters the ram, the whole pipe is bent in a long curve. The length of the drive pipe is important, and the manufacturers prefer to give information on this point for each installation. For the standard ram, however, the length is usually the same length as the lift. The end of the drive pipe in the spring or brook is protected by a strainer to keep out anything which might obstruct the valves. The area of waterway in the strainer should be two and one-half times the area of the pipe.

The ram is usually placed in a pit from which a large drain carries the excess water to a lower level. If the pipes are laid under ground and the ram is covered in winter, there is no trouble from frost, particularly when the ram is allowed to run continuously. The delivery pipe is laid with as few bends as possible to avoid friction, but this is not so important in the delivery pipe as in the case of the drive pipe. The elevated tank should be provided with a well arranged overflow pipe, as the ram keeps it full to overflowing the greater part of the time.

A satisfactory engine. Next to a natural gravity supply, the ram is the cheapest and most satisfactory means of obtaining running water. When once adjusted, it works away day and night, week in and week out, without attention, and after the first cost, which is not great, the only expense is for valves. These must be renewed every year or two according to the service.

The cost of the hydraulic ram outfit may be estimated from the following. Rams are advertised from \$5 up according to size and quality. A No. 4 standard ram such as those shown in Figs. 73, 74, 77, above, is a reliable engine, and provides an ample supply of water for a large farm; it costs \$14. The drive pipe is $1\frac{1}{4}$ inches galvanized iron pipe at ten cents per foot; the delivery pipe is $\frac{3}{4}$ inch galvanized iron pipe at 5 cents per foot; round wooden tanks of 500 gallons capacity cost from \$12 up, 1,000 gallons from \$20 up. A No. 4 standard ram requires a flow of from 3 to 7 gallons a minute from the brook or spring. It will pump from 15 to 35 gallons per hour. It raises this amount 20 feet when the fall is 3 feet, 70 feet

when the fall is 10 feet, and 120 feet when the fall is 17 feet.

In purchasing water-supply materials of any kind, it is well to remember that a cheap outfit is not necessarily an inexpensive one. It is better to pay a little more for a first-class outfit that will last a lifetime.

CHAPTER XIV

METHODS OF PUMPING

THE HOT-AIR ENGINE

THE hot-air engine is used almost exclusively for pumping water. The source of energy is the heat of combustion of some form of fuel. The energy is transferred to the power piston by means of air which is alternately heated and cooled, the same air being used over and over again. It pumps water from deep or shallow wells and is used in connection with either an elevated storage tank or a pneumatic tank. The



Fig. 78. Ericsson hot-air engine.

pump or pump head is attached to the body of the engine. Fig. 78 shows one form of the Ericsson hot-air engine, the Denney, arranged

for pumping water, from a shallow well or cistern. In Fig. 79 a sectional view of the same engine is shown.

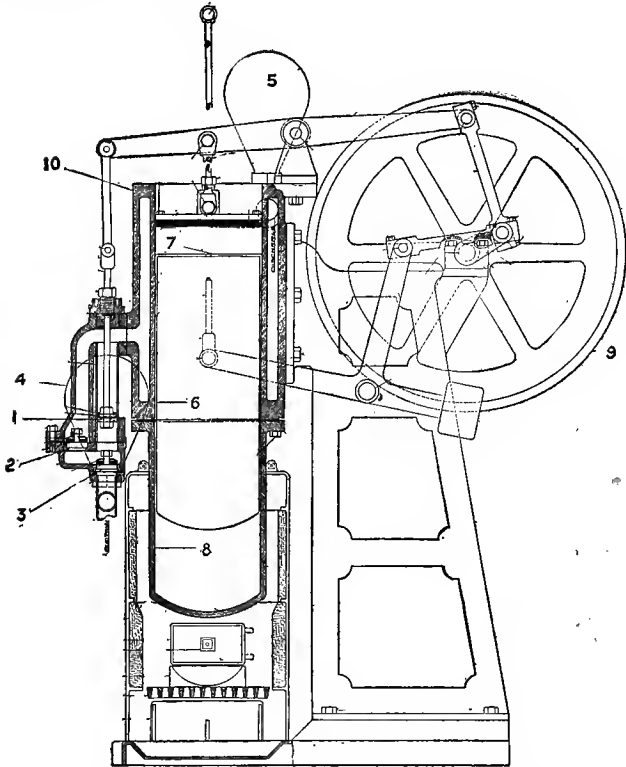

Fig. 79. Sectional view of Ericsson hot-air engine.

How the Ericsson hot air engine works.
In the Ericsson engine there is a single cyl-

inder, the lower end of which is heated and the upper end cooled. The air is alternately transferred from one end of the cylinder to the other. When at the hot end it expands and forces up the power piston; when at the cold end it cools and contracts and allows the fly wheel to drive the power piston down again.

In Fig. 79 the lower half of the cylinder 8 is in the furnace where it is heated, the upper half is surrounded by the water jacket 10 which keeps it cool. All the water pumped passes through this water jacket and serves as a cooling agent. Inside the cylinder are two pistons, the power piston 7 and the transfer piston 6. The power piston fits the cylinder so closely that no air escapes. The transfer piston, however, fits the cylinder loosely, and as it moves up and down the air passes between it and the cylinder readily. In doing so the air is alternately brought in close contact with the heating surface below and with the cooling surface above, and thus is alternately heated and cooled. The pistons are connected to the fly wheel 9 in such a manner that the transfer piston is always one

half stroke ahead of the power piston. They move in the same direction one half the time and in the opposite direction the other half.

In Fig. 79 the power piston 7 has made about one half of its up stroke and the transfer piston 6 has nearly completed its full up stroke. The air has been forced down by the transfer piston to the lower end of the cylinder where it is being heated; it is expanding and is forcing up the power piston. While the power piston makes the latter half of its up stroke, the transfer piston makes the first half of its down stroke, and one half of the air is forced to the upper half of the cylinder where it is cooled. This decreases the air pressure in the cylinder and the fly wheel is able to start the power piston on its down stroke. When the power piston has made one half of its down stroke, the transfer piston has made its full down stroke, and all the air is in the upper part of the cylinder being cooled. This decreases the pressure still further and enables the fly wheel to force the power piston to the end of its down stroke. By the time the power piston finishes its down stroke, the transfer piston has made

one half its up stroke, and half of the air is in the lower end of the cylinder being heated again. It expands and forces the power piston up. By the time the power piston has made half its up stroke, the transfer piston has finished its up stroke, and all the air is in the lower end being heated. All the air is at this instant expanding and is forcing up the power piston, etc., etc. This operation is repeated over and over again as long as there is sufficient heat in the furnace.

The pump or pump head is attached to the body of the engine. The lift bucket 1 is operated by the walking beam, which in turn is driven by the power piston. The water passes up from the supply pipe through the suction valve 3 and the check valve 2. It then flows around the water jacket and out through the discharge pipe. There are two air chambers, one, 4, on the supply pipe and the other, 5, on the discharge pipe. They serve to moderate the strain on the engine and pump.

The Rider hot air engine. The Rider engine works on the same principle as the Ericsson, but has two cylinders instead of one.

The air is alternately transferred from one to the other, being heated in one and cooled in the other. One form of this engine, the Denney, is shown in Figs. 80 and 81. In Fig. 81 the power piston 2 works in the hot cylinder 5, the lower end of which projects into the furnace. The transfer or compression piston

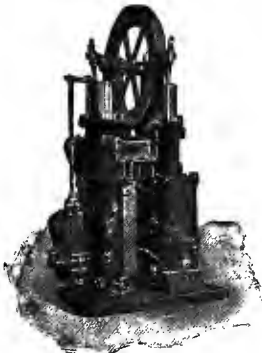

Fig. 80. Rider hot-air engine.

3 moves in the second cylinder, which is kept cool by the water jacket 7. Both pistons fit their cylinders so closely at the top that no air escapes. The pistons are attached to the fly wheel 1 in such a manner that the compression piston is always a half stroke behind the power piston. The air is transferred from the hot to the cold piston and back again through the chamber 4, called the regenerator, which is filled with thin metal plates one-eighth of an inch apart. It is called the regenerator because, as the hot air passes between the thin metal plates, it gives up part of its heat to them, and as the cool air comes back

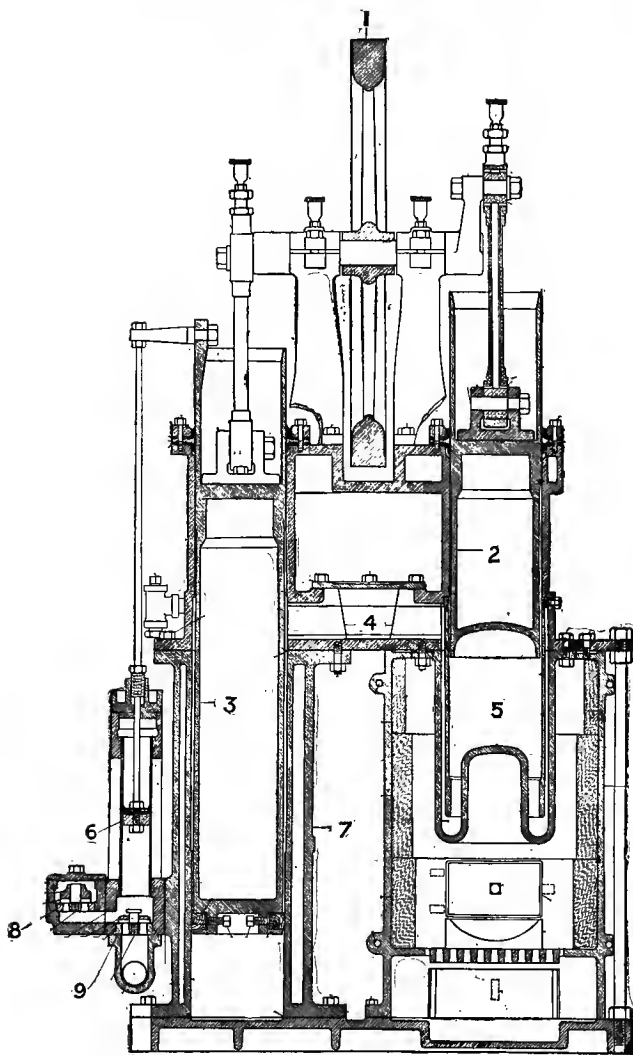

Fig. 81. Sectional view of Rider hot-air engine.

between the plates it takes up some of the heat again. A better name would be "economiser," as it economises heat.

How the Rider engine works. In Fig. 81 the power piston 2 and the compression piston 3 are both being forced up by the air which is being heated in 5. The power piston is near the top of its up stroke and the transfer piston has made about half of its up stroke. Part of the air is over in the cold cylinder being cooled. This decreases the pressure and allows the fly wheel to start the power piston on its down stroke. While the power piston is making the first half of its down stroke, the compression piston finishes its up stroke, and at this point the greater part of the air is in the cold cylinder and the air pressure is at its lowest. While the fly wheel is forcing the power piston through the latter half of its down stroke, the compression piston makes the first half of its down stroke, and the air is compressed in both cylinders.

The instant the power piston starts on its up stroke, the compressed air from the cold cylinder moves through 4 into the hot cylinder

5, and as it is heated it expands and forces up the power piston. All the time the power piston is making the first half of its up stroke, the compression piston is moving down and is forcing air over into the hot cylinder, where it is rapidly heated and adds to the upward pressure on the power piston. While the power piston is making the latter half of its up stroke the compression piston is also moving up. Air passes over into the cool cylinder and the pressure decreases so that the fly wheel is able to start the power piston on its down stroke, helped by the fact that while the power piston is making the first half of its down stroke the compression piston is still moving up and the air exerts an upward pressure on it. These operations are repeated over and over again as long as there is sufficient fire in the furnace.

The action of the pump is the same as in the Ericsson engine. All the water passes through the cooling chamber 7. There is an air chamber on the suction pipe and another on the discharge pipe, neither of which are shown in the figure.

To start the hot air engine a fire is lighted

in the furnace, and when the bottom of the cylinder has been heated red hot—a cherry red—the fly wheel is given a turn or two by hand. The engine will then continue pumping until the fire dies down. The light of the fire makes it difficult to tell when the heater pot is cherry red; but if a black shovel is placed between the fire and the pot, the color is easily seen. While the pot is being heated, the air-cock should be left open to allow any oil or water, which may have accumulated in the pot, to pass out in the form of vapor. If the oil is not expelled, it carbonizes and forms a soot which clogs the pistons. If the water is not expelled, the steam formed might blow out the power piston. Before the engine is started, the fly wheel should be given two or three turns by hand while the air-cock is open; the pistons, moving up and down, then force out the last of the oil and water vapors and draw in fresh air. The engine and pump should be kept well oiled; but care should be taken not to put too much oil on the pistons; they should be kept just moist and the oiling should be done with a rag on a stick,

or with a small varnish brush. It should not be done with the oil can.

The Rider and Ericsson engines have been on the market many years and have given excellent satisfaction as pumping engines. They may be adapted to any kind of fuel and use very little of it. They are practically noiseless and they do not require skilled attendance.

The cost. The cost of a hot-air engine equipment may be judged from the following. The price of the Ericsson engine with a six-and-one-half-inch cylinder is \$130. It has a pumping capacity of from 150 to 300 gallons per hour according to the height the water is pumped. The Rider engine, with power cylinder six inches in diameter, costs \$240, and has a pumping capacity of from 500 to 1,000 gallons per hour according to the height. These prices include engine and deep or shallow well pump; to get the total cost of the system it is necessary to add the cost of the elevated or pneumatic tank, according to which system is used.

CHAPTER XV

METHODS OF PUMPING

THE GASOLINE ENGINE AND STEAM ENGINE

ON thousands of farms the gasoline engine is doing work that was formerly done by hand. There are many reasons for this change: first, farm help is hard to get and the outlay in wages is high; second, the gasoline engine has reached such a state of perfection that it is thoroughly reliable; third, it is cheaper to do work with an engine than to do it by hand labor.

This last point is the chief reason for the general use of the gasoline engine in farm work. It is cheaper to have an engine do the work than to do it by hand. A short calculation will demonstrate this point as follows:— A gasoline engine uses about 1 pint of gasoline per horse power per hour. With gasoline at

16 cents a gallon the "horse power hour" of work is done at a cost of 2 cents.

An average man, working steadily all day, works at a rate of about $\frac{1}{8}$ horse power. At this rate it takes him eight hours to do one "horse power hour" of work. If we take his wages at the low rate of \$1.00 a day, it costs 80 cents to get the one "horse power hour" of work done by hand. This is very high when compared to 2 cents, the cost of one "horse power hour" of work when done by a gasoline engine. Of course, to the cost of the gasoline there must be added something for oil, and also a certain amount as interest on the cost of the engine and a certain percentage for depreciation, but with all these added, it is very much cheaper to do the work with an engine. There are many tasks on the farm and elsewhere that an engine cannot do, but when an engine can do the work, it should be made to do it. If a pint of gasoline costing 2 cents can do the work it takes a man eight hours to do, the gasoline should be made to do it.

Some of the many tasks a gasoline engine may be made to do are shown in Figs. 82 and

83. It may be made to saw wood, grind grain, cut roots, run the thresher, fanning mill, grind



Fig. 82. Gasoline engine at work.

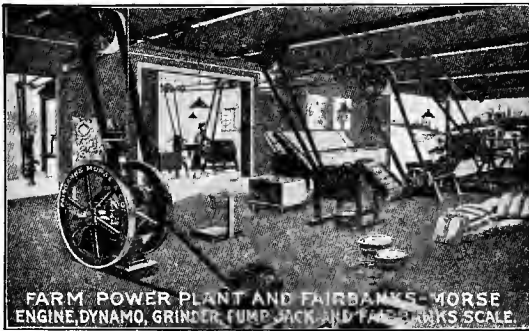

Fig. 83. Gasoline engine at work.

stone, washing machine, churn, cream separators, dynamos and pumps. In this book we are

interested chiefly in the gasoline engine as it is used to pump water.

If a gasoline engine is to be purchased for a farm, it is well to get one of six or eight horse power, capable of doing any task about the farm, the pumping included. In many cases, however, it is desirable to have a small engine for pumping water and for doing other light work. An engine of from one to two horse power is excellent for this purpose. A number of these are illustrated in this chapter.

How the gasoline engine works. The type of gasoline engine in general use on farms is called the four-cycle engine, because in every four strokes of the piston there is but one power stroke. Every engine is equipped with one or two heavy fly wheels. These heavy wheels are made to revolve rapidly by the power stroke and their momentum carries the load between power strokes. The working of the engine is illustrated in Fig. 84. It is as follows:—In (1) the fly wheel, is moving the piston down. This leaves a vacuum in the top of the cylinder, and the atmospheric pressure forces open the intake valve I and forces a mixture of gasoline va-

por and air into the cylinder, from the mixer, not shown in the figure. This downward motion of the piston is called the *charging stroke*.

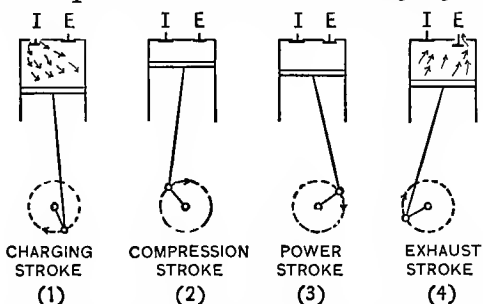

Fig. 84. Gasoline engine, one power stroke in every four strokes.

In (2) the fly wheel is forcing the piston up again. The intake valve instantly closes and the mixture of gasoline vapor and air is compressed to about one fourth its volume. This upward motion of the piston is called the *compression stroke*.

Just before the mixture is at its greatest compression an electric spark is produced in the cylinder by an automatic device, not shown in the figure. This spark ignites the mixture and the explosion or expansion produced causes a high pressure which forces the piston down. This downward motion of the piston is the *power stroke* or *working stroke*. It is shown in (3).

In (4) the fly wheel is forcing the piston up again. At the beginning of this upward stroke the exhaust valve E is opened by an automatic device, and as the piston moves up, the burned gases are forced out of the cylinder. This upward motion of the piston is called the *exhaust* stroke. On the next downward motion of the piston the atmospheric pressure forces a fresh charge of gasoline vapor and air into the cylinder and the whole operation is repeated.

Water-cooled and air-cooled engines. The mixture of gasoline vapor and air burns at a very high temperature, and to prevent the cylinder from being overheated it is necessary to cool it by some artificial means. In the water-cooled type of engine the cylinder is cooled by means of a water jacket, through which water circulates while the engine is running. In the air-cooled type the outer surface of the cylinder is made up of wide flanges which offer a large cooling

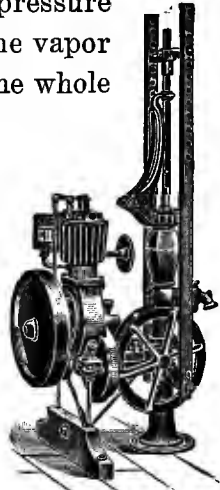

Fig. 85. Air-cooled engine.

surface, and the cylinder is cooled by radiation into the air. As the air near the cylinder is heated it expands and is forced up by the cooler air which takes its place. In some engines of this type, a small fan drives the cool air against the flanges and increases the cooling effect.

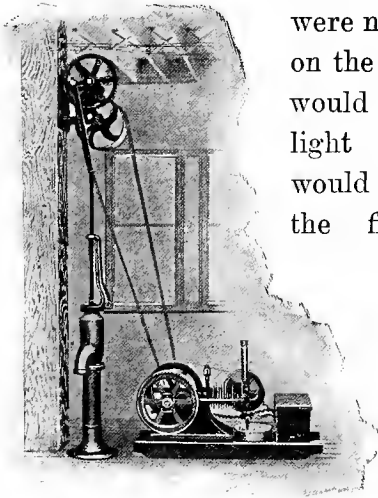

Fig. 86. Air-cooled engine.

The governor. If there were no governing device on the gasoline engine, it would run away with a light load, that is, it would run so fast that the fly wheel would burst, unless, indeed, some other part of the engine broke first.

The governor of the gasoline engine is a centrifugal device on the fly wheel. In one class of engine the governor controls the speed as follows. When the speed of the fly wheel reaches a certain point, the governor automatically opens the exhaust

valve and holds it open. Then when the piston moves up and down, air moves in and out of the cylinder through the exhaust pipe, but the cylinder does not receive a charge of the explosive mixture. As soon as the speed of the fly wheel falls below a certain point, the governor allows the exhaust valve to close, and on the next down stroke of the piston, a charge is drawn into the cylinder through the intake valve. The power strokes then continue to occur at their regular times until the speed of the fly wheel again reaches the point at which the governor holds the exhaust valve open.

In another class of engine, the governor controls a throttle valve in such a way that it cuts down the supply of gasoline when the speed becomes too great and increases the supply as the speed decreases. When properly adjusted, this form of governor keeps the speed of the engine nearly constant.

Gasoline engine and pump. The ordinary pump is connected to the engine by gears because the engine works more rapidly than the pump; for example, the two-horse-power engine makes from three hundred and fifty to five hun-

dred revolutions per minute, while the ordinary pump works at forty strokes or less per minute. For this reason the pump is connected to the engine by some form of pump jack which is back-gearred.

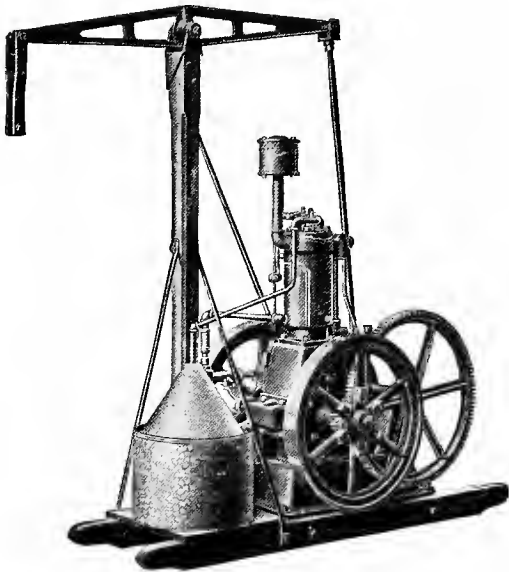

Fig. 87. Water-cooled engine geared to walking-beam pump jack.

If the pump works best at forty strokes per minute and the engine makes four hundred revolutions per minute, the jack must be back-gearred one in ten, that is, the gearing must be such, that, while the engine is making ten revolutions,

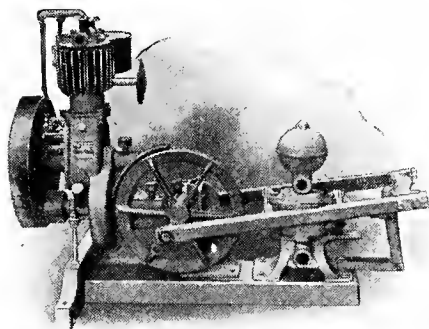

Fig. 88. Gasoline engine geared to horizontal pump jack.

the pump makes one complete stroke. An advantage of this back gearing is that the engine can lift a heavier load on the pump piston than it could if it were directly connected—with a back gearing of one in ten, ten times the load.

Rotary pumps may be connected directly to the engine. Those of small size run at a speed of from one hundred to two hundred revolutions per minute and are usually belt connected, but those of larger size, the fire pumps, run at three hundred

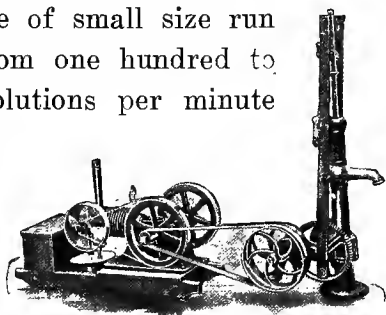

Fig. 89. Belt-driven pump jack.

and fifty revolutions per minute and over, and are usually connected directly to the engine. The direct connection is made by gears or by placing the pump on the main axle of the engine.

Centrifugal pumps also may be connected directly to the gasoline engine; they vary in speed from one hundred and fifty to over two thousand revolutions per minute. When these

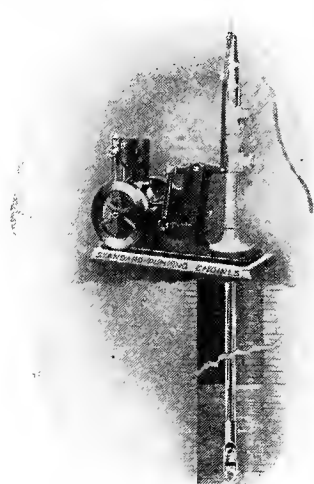

Fig. 90. Gasoline engine operating shallow well pump.

pumps are run in connection with other machinery, they are usually belt connected; but when they are run by a separate gasoline engine, they are generally direct connected.

Advantages of the gasoline engine.

The gasoline engine has many advantages as a pumping engine and as the source of power for other farm work. Some of these ad-

vantages are as follows:—It does not require the service of a trained engineer. Any man of ordinary intelligence can learn to run it in half a day or less, and learn to master it in two or three days, especially if he

takes it apart and learns the use of each part from an instruction sheet or otherwise. Like any other machine, the more intelligent care given to it, the better work it will do.

It is made in units of smaller horse power than the steam engine. It weighs less per horse power and can readily be shifted from one place to another as the work requires. There is no steam gauge to watch; no boiler to keep supplied with water; no ash to handle and the handling of fuel is limited to filling the fuel tank. It can be started in a few seconds; it gives more power than the steam engine for

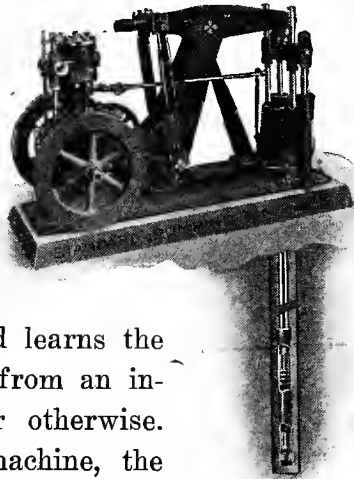

Fig. 91. Gasoline engine operating deep-well pump.

the same amount of fuel; and it will run all day without any attention whatever. It cannot possibly blow up. There is no danger of fire if the exhaust is properly guarded, and if the water is drained out of the water jacket and tank, there is nothing to freeze.

Compared to the windmill it is more powerful and is independent of the weather. The windmill has the advantage, however, that it requires no fuel.

Compared to a horse, it has the advantage that it will work without attendance and as soon as the work is done the expense stops, while a horse requires a driver and must be fed whether it is working or not. The horse has the advantage that for a short time it can work at the rate of five and even ten horse power, while an engine of one horse power can work at the rate of one horse power and no more. For this reason, it is advisable in purchasing an engine to get one of sufficient power to do the heaviest work that is likely to be required of it. The expense for fuel is nearly in proportion to the work done; for example, if a six-horse-power engine is working at the rate of only one horse

power, the gasoline used is only a trifle more than that required to run a one horse power engine. The horse can do many tasks that a gasoline engine cannot conveniently do, but on the other hand, there are many forms of work more easily done by an engine than by a horse, as, for example, running all kinds of stationary machinery. As to the relative expense, a horse does a day's work—ten horse power hours of work—at a cost of about thirty-five cents, for food and care in stable. A gasoline engine, using one pint of gasoline per horse power per hour, does ten horse power hours of work at a cost of twenty cents with gasoline at sixteen cents a gallon.

Prices. To give the reader an idea of the



Fig. 92. Portable engine at work.

cost of gasoline engines the following prices are quoted from the catalogue of manufacturers who sell direct from the factory to the consumer.

1 Horse power \$53.50; 2½ H. P. \$78.50; 5 H.

P. \$119.50; 7½ H. P. \$205; 10 H. P. \$265; 15 H. P. \$350.

The Steam Engine. The steam engine is rarely used exclusively for pumping water except in large municipal pumping plants. In many villages and towns, however, there are

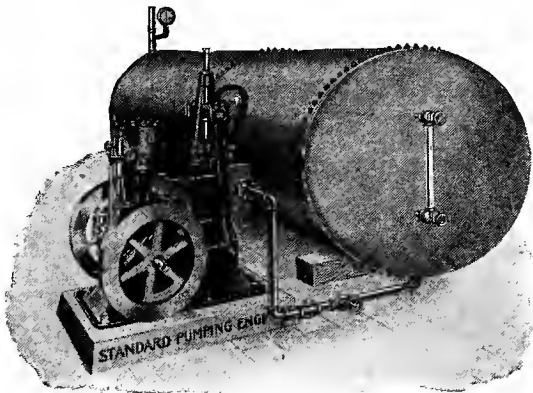

Fig. 93. Gasoline engine operating a pneumatic tank.

factories with steam power, which might easily be equipped to supply a whole section of the town or village with running water. One method of doing this is to instal a pump and elevated or pneumatic tank at the factory, with piping to the houses, or, if the factory runs night and day, a steam pump with an automatic

control valve may be used to pump directly into the supply pipe; the automatic valve is set for a certain pressure and it stops and starts the pump when the pressure goes slightly above or below this pressure. Any such pumping arrangement would be profitable to the factory as well as to the householders. The factory engineer could look after the pumping and since there would thus be no extra outlay in wages the revenue would be nearly clear gain to the factory. The householders also would receive a water service at less trouble and expense than if each had an individual water-supply system. On farms which have steam power, the equipment for water supply is also a simple matter. The steam engine may be used with any form of pump, and is connected to it by means of a pump jack or belt and pulleys. If there is only a steam boiler, as in some dairies and cheese factories, the boiler may be connected directly to a steam pump.

Prices. Vertical boilers connected to vertical engines are advertised at the following prices: two-horse-power boiler with one and one-half horse-power engine, \$103; three-horse-

power boiler with two-horse-power engine, \$122; four-horse-power boiler with three-horse-power engine, \$141.

CHAPTER XVI

METHODS OF PUMPING

THE ELECTRIC MOTOR

WHERE the electric current is available, the most convenient method of pumping water is by means of an electric motor. It may be made automatic in its action and after being once adjusted needs very little attention.

It would take more space than is available in this book, to give a detailed explanation of the working of the electric motor. In general, it may be said that an electric current is run into the motor and produces a rotary motion of the moving part of the motor, and this rotary motion is turned into a reciprocating, or to-and-fro motion, by means of a pump jack which operates the pump. The current is produced in a dynamo and the dynamo in turn is driven by means of a steam, gas, or gasoline engine, or by water power. The source of the electricity is,

then, the energy contained in fuel or in running water.

If we start at the fuel or running water, the operation, step by step, is as follows: the energy of the fuel or running water drives the engine or water motor; the engine or water motor runs the dynamo and an electric current is produced; this electric current is carried on wires to the motor and produces a rotary motion in the motor; the rotary motion may be used directly to drive centrifugal and screw pumps, or may be turned into a reciprocating motion by means of a pump jack, to drive an ordinary pump.

To the beginner in electricity the chief difficulty is not so much to learn how the various electrical machines work, as it is to get a clear notion of the meaning of the various terms used. Electricity is a comparatively new science and, of necessity, there have been a number of new terms introduced. Some of these terms are volt, coulomb, ampere, joule, watt. These are derived from the names of distinguished scientists and do not in themselves convey any meaning. A fair working knowledge of their mean-

ing may be obtained, however, by comparing the work done by an electric current, with that done by a current of water, as for example, at a waterfall.

In English-speaking countries we measure work in foot-pounds. When 1 lb. weight is raised 1 foot, 1 foot-pound of work is done. When 2 lbs. is raised 5 feet, or 5 lbs. 2 feet, 10 foot-pounds of work are done, etc.; also if a 2 lb. weight can fall 5 feet, it is capable of doing 10 foot-pounds of work, etc.

To measure the work which may be done by a waterfall we measure the height of the fall and the weight of water that passes over it per second. For example, if the height of the fall is 20 feet, and 55 pounds of water pass over it per second, it is capable of doing 20×55 , or 1,100, foot-pounds of work each second. Also we measure the rate of working in horse powers. If any engine can do 33,000 foot-pounds of work each minute, or 550 foot-pounds each second, we say that it is capable of working at the rate of 1 horse power. A waterfall 20 feet high, over which 55 lbs. of water pass each second, can do 1,100 foot-pounds of work per

second, and is capable of working at the rate of $\frac{1,100}{550}$ or 2 horse powers.

In measuring the work that an electric current can do, the volt corresponds to the foot used to measure the fall. The coulomb measures the quantity of electricity and corresponds to the pound which measures the quantity of water. If 1 coulomb of electricity passes along a wire in 1 second the current is said to be flowing at the rate of 1 ampere, 10 coulombs a second is a 10-ampere current, 10 coulombs in 5 seconds is only a 2-ampere current, because only 2 coulombs pass any point in 1 second. When 1 pound falls 1 foot it does 1 foot-pound of work. When 1 coulomb falls 1 volt, it does 1 joule of work, that is, the joule is a certain amount of work, just as the foot-pound is a certain amount of work. When the current does 1 joule of work each second, it is working at the rate of 1 watt; that is, the watt is used to measure the rate of working and is similar to horse power, which is a rate of working. If 50 joules of work are done in 1 second the rate of working is 50 watts. If 50 joules are done in 5 seconds the rate is only 10 watts or 10 joules

per second. It must not be understood that a volt is equal to a foot, or a coulomb to a pound, etc. The volt, coulomb, etc., are simply used to measure electrical power in the same way that the foot, the pound, etc., are used to measure water power.

In ordering an electric motor for pumping purposes, it is necessary to let the manufacturers know the quantity of water to be pumped, the depth of the well, the height the water is to be lifted into an elevated tank, or the pressure against which it must pump into a pneumatic tank. They must also know the voltage of the electric current used; whether the current is direct or alternating; if alternating, whether it is one-, two- or three-phase; and also the number of cycles. Information about the electric current should be obtained from the electric company that furnishes the current.

There are two kinds of electric current, the direct and the alternating. The direct current is one in which the electricity flows in the same direction all the time. The alternating current is one in which the direction in which the electricity flows is reversed many times in a second.

The number of reversals per second is known as the frequency or the cycles. Some dynamos produce one alternating current, some two and others three, and these currents are known as one-phase, two-phase and three-phase currents respectively. The two- and three-phase currents are generally used to run alternating current motors.

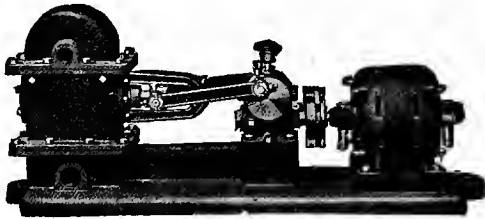

Fig. 94. Motor-driven pump.

The electric motor runs at a speed of about one thousand six hundred revolutions per minute and the ordinary pump about forty strokes per minute; therefore in connecting the pump to the motor a back gearing of about one in forty is required, so that the motor makes forty revolutions for each complete stroke of the pump. In the pump shown in Fig. 94 the back gearing is a worm gear which works in an oil bath. The worm gear is a compact form of

back gearing and the oil bath serves to keep the gear lubricated and also makes it practically noiseless.

Fig. 95 is an illustration of a pneumatic-tank outfit in which an electric motor and pump are used to pump water or water and air into the tank.

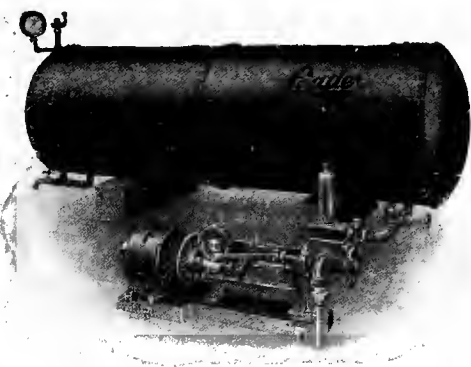

Fig. 95. Motor-driven pump operating a pneumatic tank.

Automatic switches. The electric motor may be started and stopped by a hand switch or by an automatic switch. The automatic system is extremely convenient, as, after it is once adjusted, a constant water supply is maintained with practically no attention.

One form of automatic switch, used in open tanks, is shown in Fig. 96; a spherical copper

ball floats on the water in the tank and is connected to the motor switch by a chain which has a weight at the other end. When the level falls to a certain point, the lever of the switch is forced up by the weight of the ball. This

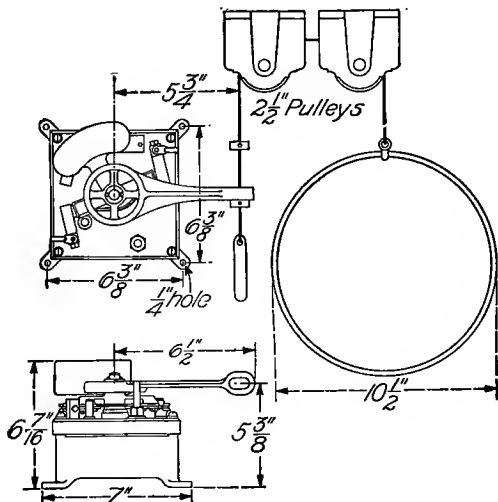

Fig. 96. Automatic switch for open tanks.

closes the electric circuit and the motor starts pumping. When the level is raised to a certain point, the lever is pulled down by the weight and the motor stops. With such a switch, the water level does not vary by more than five or six inches.

One form of automatic switch, used on closed pneumatic tanks, is shown in Fig. 97. When the pressure in the tank reaches a certain amount the switch is forced open and the motor stops. When the pressure falls below a certain amount the spring forces the lever back and the motor starts pumping again. With this switch, the air in the tank is kept within a few pounds of a certain pressure, and the only time the system needs attention is when air is pumped in, about once a week. In some outfits, the trouble of looking after the air supply is done away with by means of a float placed in the tank; it is so arranged that when the air supply is decreased to a certain amount, the float opens the air-cock in the suction pipe and air is pumped in with the water; and when the air supply is increased to the correct amount, the float closes the air-cock again.



Fig. 97. Automatic switch for closed tanks.

A convenient system. The electric motor

has many advantages as a pumping engine. The most important is the small amount of attention required. Closing a switch starts it and opening the switch stops it, and when this is done automatically there is practically nothing to do, as most motors are self-oiling. Another advantage of the automatic system is that a very much smaller tank may be used since the water level never falls below a certain mark. The motor takes up little space, it is clean, and there is no handling of ashes or fuel. It is practically noiseless, and when connected to a noiseless pump makes a very desirable combination for use in the house.

CHAPTER XVII

WATER POWER

THERE are three types of engines driven by water power, namely, water pressure engines; water wheels; and turbines.

The water-pressure engine works very much like a steam engine. It uses water under pressure in much the same way that a steam engine uses steam under pressure. There is a piston which moves back and forth in a cylinder. Valves operated by an eccentric admit the water first at one end of the cylinder and the piston is driven forward, then at the opposite end and it is driven back. While the water under pressure is being admitted at one end, the spent water is forced out at the other. The piston thus has a reciprocating motion and may be used to pump water from a well or cistern into an elevated tank.

One form of this engine known as the "water lift" is a water-pressure engine and pump

combined. Those on the market work with water at fifteen pounds pressure or over. In cities where the water supplied by the municipal plant is very hard, the water lift is in general use to pump soft water for washing purposes, from a cistern into an elevated tank.

The water lift can also be used in the country where water with sufficient pressure is available. We learned in the chapter on the pneumatic water-supply system that water 2.3 feet deep exerts a pressure of 1 lb. per square inch. According to this, 15 lbs. pressure requires a depth of $34\frac{1}{2}$ feet. If then water with a fall of 35 feet or over is available the water lift may be used to pump water from a well or cistern into an elevated tank.

A No. 4 water lift costs \$32.00, uses 200 gallons of water per hour at a pressure of 15 lbs., and will lift 100 gallons per hour to a height of fifty feet. The price does not include cost of pipe. Three-quarter inch piping at 5 cents per foot is used for supply, waste, suction and discharge.

If a water supply 35 feet high is fit for drinking, and is above the level of the house and

stables, the simplest method, of course, is to pipe it directly to the house and stables. If it is below the level of the house a hydraulic ram is the simplest and cheapest method of pumping it. If, however, the water is very hard, it may be piped to the house and part of it used as drinking water, and part of it used to run the water lift to pump soft water for use in the bath and laundry.

Waterwheels. The term waterwheel applies to water motors which receive the force of the water only on one side of the circumference of the runner, and the term turbine to those which are acted on by the water at all points of the circumference of the runner at the same time.

The waterwheel is used extensively in the West as a pumping engine for irrigating purposes. It is also used to some extent in both the East and West as a source of power for all forms of farm machinery. There are four types of water wheels: the undershot wheel; the breast wheel; the overshot wheel; and the impulse wheel.

The undershot wheel is used where the river

has a slight fall. It is made of a series of paddles attached to a horizontal axle, very much like the paddle wheel of a steamboat (see Fig. 98). When used in a large stream to pump water, it is placed between two pontoons

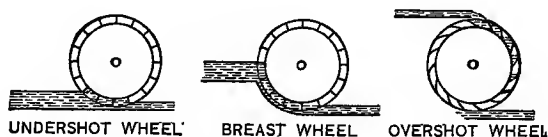

Fig. 98. Waterwheels.

anchored in the stream, and the water is either lifted in buckets attached to the wheel, or by means of an ordinary pump attached to the end of the axle by a crank and pitman. When used in small streams, the stream is generally narrowed to the size of the wheel.

If the fall in a small stream is only a few feet, a breast wheel is generally used (see Fig. 98). The water meets the paddles at the level of the axle and exerts a force due partly to its weight and partly to its velocity.

In the overshot wheel the paddles are made in the form of buckets (see Fig. 98). These are filled with water when at the top of the wheel

and emptied when at the bottom. The water exerts a force due to its weight only.

Impulse wheel. The two types of water motor in most common use are the impulse wheel, such as the Pelton wheel shown in Figs. 99 and 100, and the turbine wheel, such as the Leffel wheel shown in Figs. 101 and 102. The Pelton wheel is

a high-head wheel. It uses a small quantity of water at a high head. The turbine wheel uses a large

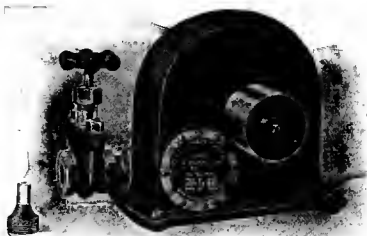

Fig. 99. The Pelton wheel

quantity of water at a low head. The Pelton is used on heads from twenty feet to over two thousand feet and the turbine on heads from three to one hundred and fifty feet or over. The Pelton is a steel or cast-iron wheel with curved buckets attached to the rim. The water is carried to the wheel in a sheet steel pipe and is discharged tangentially into the buckets through a small nozzle. The water strikes the buckets and is curved around so that when it

leaves them, it has no velocity relative to the earth, but relative to the buckets it is moving in the opposite direction to that at which it entered them. It is found that this wheel is most efficient when it moves at one-half the absolute velocity of the jet. On a head of one hundred feet the absolute velocity of the jet is eighty feet per second. If the buckets are moving with a velocity of forty feet per second, the water enters the buckets with a velocity, relative to them, of forty feet per second. This velocity is reversed and the water is given a backward velocity of forty feet per second relative to the buckets, but this is a velocity of zero, relative to the earth.

It is a maxim in hydraulics that the water moving into a motor should "enter without shock and leave without velocity." We have seen how the water leaves the buckets without velocity. It enters them without shock because it enters at the outer edge when this edge is almost parallel to the direction in which the jet is moving. The water is split by the middle partition and each half is directed backwards and also a little to one side so that it does

not interfere with the movement of the next bucket (see Fig. 100). The Pelton is very compact and gives a large amount of power from a small quantity of water on a high head; for example, a wheel only two feet in diameter on a head of one hundred feet gives about six horse power, uses



Fig. 100. Nozzle, jet and buckets of Pelton wheel.

forty-seven cubic feet of water per minute, and makes three hundred and fifty revolutions per minute.

The turbine. The turbine uses a large amount of water on low heads. The water is admitted at all points of the circumference through guides which may be opened or closed. There are three types of turbines, namely, the inward, the outward, and the downward discharge. The names refer to the direction in which the water moves. In the inward-discharge turbine the water enters at the outer circumference of the wheel and leaves at the inner. In the outward-discharge the

reverse, and in the downward-discharge the water enters at the top and leaves at the bottom. The guides are curved in such a manner that the water leaves them, and enters the blades, in the direction in which the blades are moving. The blades are curved in such a man-

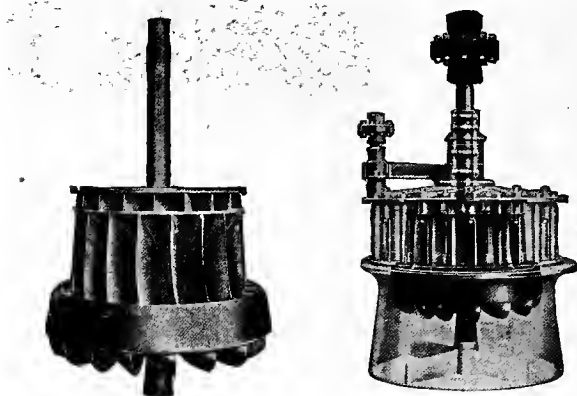

Fig. 101. The Samson runner. Fig. 102. The Samson turbine.

ner that the direction of the water is reversed as it passes through them, and when it leaves them it has only a small velocity relative to the earth.

The runner of the Samson turbine (Fig. 101) has two distinct types of wheels joined in one. Each part of the wheel receives its separate quantity of water from the guides. The upper

is an inward-discharge wheel and the lower an inward and downward discharge wheel. The runner is placed inside a guide casing, as shown in Fig. 102. The small vertical shaft at one side is used to open and close the guides. The complete wheel is placed in a penstock just above the tailrace. The water enters the penstock from the channel above, passes through the guides, exerts its force on the runner and passes out through the tailrace. A Samson turbine is compact and powerful. A turbine with twenty-four-inch runner develops over six horse power on a five-foot head. It uses nine hundred cubic feet of water per minute, and makes two hundred and eight revolutions per minute.

To find the horse power of a stream. Any machine is working at the rate of 1 horse power when it does 33,000 foot-pounds of work each minute. To calculate the rate at which a stream may be made to do work, it is necessary to know the weight of water that flows past any point in a minute and the number of feet fall. For example, if one thousand one hundred lbs. of water per minute fall 40 feet the

stream is capable of doing 44,000 foot-pounds of work per minute, or its rate of working is $\frac{44,000}{33,000} = 1\frac{1}{3}$ horse power.

To find the height of fall, the vertical distance from the lowest point to the highest point available is measured in feet. There are different methods of measuring the rate of flow of water. In large streams the velocity may be measured as follows:—Choose a part of the stream where the banks are nearly straight and parallel; measure the distance between two points on the bank; place chips of wood in the center of the stream and find the time it takes them to traverse the distance between the stakes. Take the average of four or five measurements and find the distance traveled per minute in feet. The velocity of the water in the center and at the surface is more rapid than that at the sides and bottom. Engineers tell us that the mean velocity of the stream is eighty-three hundredths of the velocity at the center and surface.

To find the cross section of a stream, a point where the sides are straight and parallel is chosen, and stakes are driven at equal distances across the stream, the end stakes being a half

space from the banks; for example, if the stakes are eight feet apart, the end stakes are four feet from the bank on each side. The depth at each stake is taken, these are added together and divided by the number of stakes, which gives the average depth; this average depth is then multiplied by the width of the stream from bank to bank, and the product is the area of cross section of the stream in square feet.

When we have found the fall, the velocity, and the area of cross section of the stream, we find the horse power of the stream as follows. The area is multiplied by the velocity in feet per minute and gives the quantity of water in cubic feet which flows past any point per minute. A cubic foot of water weighs sixty-two and one-half pounds. If the total number of cubic feet per minute is multiplied by sixty-two and one-half, the result is the weight of water in pounds that flows past any point in a minute. If this weight in pounds is multiplied by the feet fall and divided by 33,000 the result is the horse power of the stream. Example: if a stream is 40 feet wide: with an average

depth of 3 feet, a mean velocity of 22 feet per minute, and a fall of 10 feet, its horse power is as follows:—

$$\frac{40 \times 3 \times 22 \times 62\frac{1}{2} \times 10}{83,000} = 50 \text{ H. P.}$$

An estimate of the power of a small stream may be made in the manner described above for large streams. Two more accurate methods, the weir method and the miner's inch, are carefully described in the catalogues of manufacturers of water-power equipment. (For names and addresses of these firms see list in the back of this book.) A stream should be measured in the late summer when the flow of water is least, and after the measurement of horse power is made as above, it is well to divide the number by two, as there is always a certain amount of power lost and it is well to be on the safe side.

Water power on the farm. Water power is adapted to any kind of work that may be done by a steam or gasoline engine as, grinding grain, cutting roots, sawing wood, pumping water, etc. It may be used to run a dynamo to generate electricity to light the house and

stables, and for power purposes. In some cases a number of farmers club together to instal an electric plant large enough to light all their homes and barns. In the daytime the current is used to do other work by means of electric motors. Before such an enterprise is undertaken, the whole question should be gone into with the manufacturers of water-power equipment, or with manufacturers of electric equipment, to see what may be expected, what the cost will be, and what results the manufacturers will guarantee.

In Chapters XII to XVII, the different methods of pumping water have been described, namely, by hand power, horse power, windmill, hydraulic ram, hot air engine, gasoline engine, steam engine, electric motor, and water motor. Under given conditions one of these is the best to use; the descriptions given in these chapters will help the reader to decide which method of pumping is the best to use under the conditions in which he finds himself,

CHAPTER XVIII

PLUMBING AND SEWAGE DISPOSAL

IN this series of books, there is one on "Health on the Farm" which deals with plumbing appliances. This chapter is therefore limited to the discussion of a few general points.

Hot water supply. The working of the hot-water tank described in Chapter II depends on the fact that when water is heated it expands, and therefore, volume for volume, hot water is lighter than cold water.

If a pipe such as that shown in Fig. 103 is filled with water and heated on one side, the

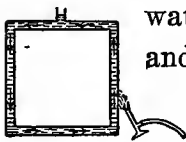

Fig. 103.

water on the heated side expands and therefore, volume for volume, is lighter than the cold water on the other side. The cold water being heavier sinks down and forces the hot water to the top; this cold water in turn becomes heated and is forced up by more cold water. The water on the un-

heated side is always colder than that on the heated side, therefore it is always somewhat heavier. As long as one side is heated the cold water sinks and forces up the warmer water, and the circulation continues in the direction shown by the arrows.

This is precisely what takes place in the hot-water tank and water front. The water in the water front is heated by the fire in the kitchen stove. The cooler heavier water in the tank sinks down and forces the hot water to the top of the tank. The cold water is in turn heated and is forced up by cooler water from the tank. This circulation continues as long as there is a fire in the stove. When a hot-water tap is opened cold water from the storage tank sinks into the hot water tank and forces hot water from the top of the hot water tank through the hot water pipe and out at the tap.

Bathroom equipment. The kitchen is the part of the home which should be first equipped with water-supply conveniences, because there the greatest saving in labor is made. A well-equipped bathroom, however, is a joy to every

member of the family, and the cost of adding it to the home is not great, as will be seen from the prices quoted below.

The bathroom may contain simply a bath tub with hot and cold water taps, or it may contain a bath tub and wash bowl, or bath tub, wash bowl and slop sink, or bath tub, wash bowl and water closet. If the bathroom has no water closet, so that all the wastes are liquid, the drain pipe may empty into a tile drain such as the one described in Chapter II. In this case the drain should be made from seventy-five to one hundred feet long. The tile may be laid in a straight line or with a number of shorter branch lines. If there is a water closet the waste must be taken care of by one or other of the methods described below.

The method of connecting the bathroom fixtures to the soil pipe, and the arrangement of the soil pipe are shown in Fig. 104. The waste pipe of each fixture is trapped before it enters the soil pipe, and the soil pipe is also trapped at some point between the fixtures and the cess-pool or septic tank. The latter trap is not necessary if the end of the soil pipe curves down

below the liquid in the septic tank or tight cess-pool as shown in Fig. 105.

To ventilate the soil pipe, a fresh air inlet pipe is connected to it, at some point between the house fixtures and the soil pipe trap, and the soil pipe is extended up above the roof and left open at the top. In cold climates the soil pipe trap and inlet pipe connection are usually placed in the cellar, to avoid the danger of the soil pipe's being frozen up by the cold air

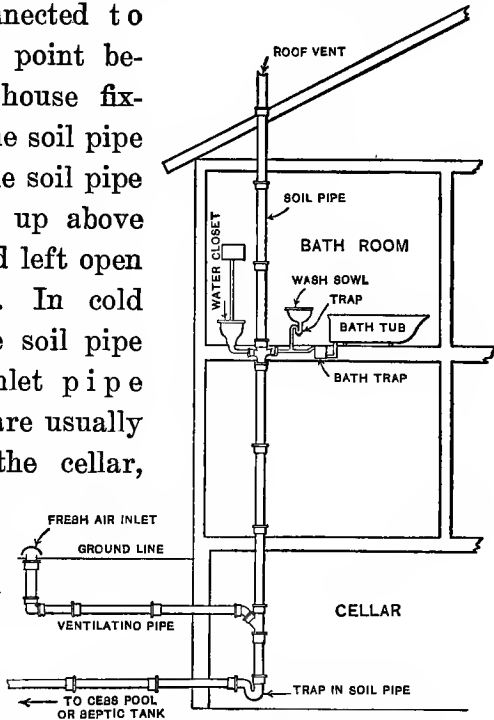

Fig. 104. Bathroom fixtures connected to soil pipe.

which enters the inlet pipe. In warm climates the soil pipe trap may be placed near the cess-pool or septic tank and the inlet pipe connection

at some point between the pipe and the house. The ventilation takes place as follows:— The soil pipe in the house is warm and the air in it is warmer and lighter than the air outside. The outer air being heavier sinks into the inlet pipe and forces the warm air up through the roof outlet. This cool air is in turn warmed and is forced up by more cold air from outside. In this way there is a constant circulation of air in the soil pipe, and both ends being open there is no chance for the sewer air to increase in pressure and force a way out through the soil pipe joints. On a warm summer day the outside air may be warmer than that in the house and in the soil pipe; in that case the circulation would be in the opposite direction.

Precautions. If a water closet is to be placed in the house, the services of an expert plumber should be secured. It is a difficult task to make the soil pipe joints tight and no one but an expert should attempt it. It was formerly the practice to place all piping in the partition walls, and to surround the bath tub, wash bowl and water closet with wood work. This, however, is no longer the case. All plumbing fixtures are

now left as open as possible so that they may be easily kept clean and easily repaired. The soil pipe particularly should be left exposed to view at all points so that any leak may be easily detected. If it is placed in a partition a long narrow door should be left from top to bottom so that the pipe may be inspected from time to time. The soil pipe usually passes down into the cellar and out through the cellar wall. It should never be placed beneath the floor of the cellar and covered up, because if the joints should open through the settling of the house or otherwise, the air of the house would be contaminated by sewer gas, and it would be difficult to locate the leak. Where the soil pipe passes through the cellar wall, the opening in the wall should be large enough to leave a space on all sides of the pipe, so that, if the foundation settles a little, the pipe is not affected. The soil pipe should be as short and as straight as possible to avoid the danger of obstruction and to remove the waste in the shortest possible time.

Prices. Bathroom outfits are advertised at \$40. They consist of cast iron enameled bath

tub, enameled iron wash bowl, water closet and flush tank; each complete with fixtures, such as taps, etc. The single items are advertised as follows: enameled iron bath tub complete, \$20 up; enameled iron wash bowl complete, \$10 up; water closet and flush tank complete, \$11.50 up; cast iron soil pipe is made in five foot lengths, and it is advertised as follows: 4-inch soil pipe, weighing $6\frac{1}{2}$ lbs. per foot, 15 cents per foot; 4-inch soil pipe, weighing 13 lbs. per foot, 25 cents per foot. These prices will help the reader to estimate the cost of a bathroom equipment for his own home. For further particulars he is advised to write for catalogues and retail prices to dealers in plumbing supplies.

Sewage disposal. The disposal of sewage is accomplished in a number of ways. Some of these are: by discharge into a sewer; by discharge into running water; by discharge into a cesspool; and by discharge into a septic tank. In villages and towns the best method is to discharge into a municipal sewer, if there is one. If there is a river or brook or larger body of water near, the sewage is usually discharged di-

rectly into it. This is a bad practice because the sewage contaminates the water and undecomposed solid wastes are deposited along the banks or shore, and the river or lake shore is then a nuisance instead of a thing of beauty. If the sewage must be discharged into a body of water it should first pass through a cesspool or septic tank and then into the water.

Cesspool. The cesspool is a hole dug in porous ground and lined with brick or stone dry set or with logs. The top is arched over with brick or concrete or simply covered with heavy timbers and earth. This method of sewage disposal is condemned by sanitary engineers because the leachings are likely to contaminate the water supply. If this method is used the cesspool should be placed from seventy-five to one hundred feet from the house on the lower side and the well an equal distance from the house on the other side on high ground.

A cesspool for the ordinary family of say six people is made ten feet square and ten feet deep; and to increase the distributing area, eight or ten drains are run out from the three sides farthest from the house. These drains

are made of three inch tile laid with open joints; they are about thirty feet long and are placed below the level of the soil pipe from the house.

In one form of cesspool the sewage empties into a water-tight chamber which is surrounded on the sides and bottom by a layer of gravel two feet thick (see Fig. 105). Near the top of the

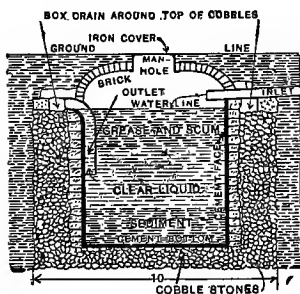

Fig. 105. Watertight cesspool.

water-tight chamber is an elbow of four-inch tile projecting below the surface of the liquid. When the chamber is filled with sewage the solid particles float on the surface or sink to the bot-

tom. The elbow allows the liquid, but not the solids, to pass out of the water-tight chamber. The liquid flows from the elbow into a box drain which extends around the chamber above the gravel. This drain distributes the liquid over the gravel. The liquid percolates through the gravel and into the porous soil. In the soil the organic impurities are filtered out and

are gradually destroyed by bacterial action. There is also strong bacterial action in the scum in the chamber. Anaerobic bacteria, which live without air, act on the solid organic matter in the scum and gradually liquify it. This prevents the accumulation of scum or sludge.

The septic tank. The best method of disposing of sewage so far devised is by means of a septic tank.

The septic tank system (Fig. 106) as commonly built consists of a tank with two chambers and a tile drain such as that described in Chapter II. The sewage enters the first cham-

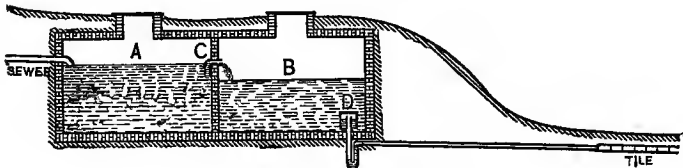

Fig. 106. The septic tank.

ber and fills it to the level of the outlet C. In time a layer of scum forms on the top of this liquid. This scum is the home of millions of anaerobic bacteria, the action of which is to liquify all organic solid matter floating on the surface. The elbow C allows only the liquid

to pass from A into the storage chamber B which is large enough to hold about twelve hours' sewage. When chamber B is filled to a certain height the siphon D automatically empties it into the tile drain. The tile are laid with open joints about eight inches to one foot below the surface at a slope of about three to six inches in one hundred feet, either in a straight line or better in rows about six feet apart. The length of tile needed varies with the character of the soil. In porous sandy soil about one foot to the gallon of sewage in one discharge, in heavy clay about three feet to the gallon. The tile may be laid under a lawn, or better, between the rows of trees in an orchard. If used in an orchard it makes an ideal system of sewage disposal because the wastes are disposed of in a safe and inoffensive manner and also the fertilizing value of the sewage is used to increase the yield of fruit. For a family of average size using five hundred gallons of water a day, each chamber of the septic tank should hold about three hundred gallons. Since a cubic foot contains seven and a half gallons, a chamber to hold three hundred gallons must have a capacity

of three hundred divided by seven and a half or forty cubic feet. If we allow one foot of space above the liquid, each chamber would be five feet long by four feet wide by three feet deep. The tank may be made of plank but for a permanent job it should be built of brick or stone set in cement with a lining of cement.

In conclusion. In planning a water-supply system one should keep two points in mind: first, all rooms in which water pipes are placed must be kept warm in winter; second, the sewage disposal system should be as carefully planned as the water-supply system.

ACKNOWLEDGMENT

The writer wishes to thank his friend and former chief, Dr. James W. Robertson, of Ottawa, Canada, for kindly consenting to write the introduction, and Professor Ernest Ingersoll of New York, and Arthur Allebone of Montreal, for valuable aid in revising the proof.

The writer also tenders his thanks to the following named firms for their kindness in lending cuts for illustration, as follows:—

Fig. 11. The Goulds Mfg. Co., Seneca Falls, N. Y.

Fig. 13. Sears, Roebuck & Co., Chicago, Ill.

Fig. 16. Fairbanks Morse Co., Chicago, Ill.

Fig. 21. J. Vanderleck, Macdonald College.

Figs. 35, 36, 37, 38, 39, 40, 41, 42. F. E. Myers & Bro., Ashland, Ohio.

Figs. 43, 44. The Goulds Mfg. Co., Seneca Falls, N. Y.

Figs. 45, 47. Ingersoll-Rand Co., New York.

Fig. 48. Sears, Roebuck & Co., Chicago, Ill.

Fig. 49. Stover Mfg. Co., Freeport, Ill.

Fig. 50. Andrews Heating Co., Minneapolis,
Minn.

Fig. 51. The Goulds Mfg. Co., Seneca Falls,
N. Y.

Figs. 52, 56. Leader Iron Works, Decatur,
Ill.

Figs. 54, 55. Kewanee Water Supply Co.,
Kewanee, Ill.

Fig. 59. The Goulds Mfg. Co., Seneca Falls,
N. Y.

Fig. 61. Montgomery Ward & Co., Chicago,
Ill.

Fig. 62. Stover Mfg. Co., Freeport, Ill.

Fig. 63. Flint & Walling, Kendallville, Ind.

Figs. 64, 65. Sears, Roebuck & Co., Chicago,
Ill.

Fig. 66. F. E. Myers & Bro., Ashland, Ohio.

Fig. 67. Flint & Walling, Kendallville, Ind.

Figs. 68, 69. Sears, Roebuck & Co., Chicago,
Ill.

Fig. 70. Montgomery Ward & Co., Chicago,
Ill.

Fig. 71. Fairbanks Morse Co., Chicago, Ill.

Fig. 72. F. E. Myers & Bro., Ashland, Ohio.

Figs. 73, 74. The Goulds Mfg. Co., Seneca Falls, N. Y.

Figs. 75, 76. Niagara Hydraulic Engine Co., New York.

Fig. 77. Rumsey Co., Ltd., Seneca Falls, N. Y.

Figs. 78, 79, 80, 81. American Machine Co., Newark, Delaware.

Fig. 82. International Harvester Co., Chicago.

Fig. 83. Fairbanks Morse Co., Chicago.

Fig. 85. Fuller & Johnson Mfg. Co., Madison, Wis.

Fig. 86. Gilson Mfg. Co., Fort Washington, Wis.

Fig. 87. International Harvester Co., Chicago.

Fig. 88. Fuller & Johnson Mfg. Co., Madison, Wis.

Fig. 89. Gilson Mfg. Co., Fort Washington, Wis.

Figs. 90, 91. Standard Pump & Engine Co., Cleveland, Ohio.

Fig. 92. The William Galloway Co., Waterloo, Iowa.

Fig. 93. Standard Pump & Engine Co.,
Cleveland, Ohio.

Figs. 94, 96, 97. Fort Wayne Engineering &
Mfg. Co., Fort Wayne, Ind.

Fig. 95. Leader Iron Works, Decatur, Ill.

Figs. 99, 100. Pelton Water Wheel Co., New
York.

Figs. 101, 102. Jas. Leffel & Co., Springfield,
Ohio.

Fig. 104. Chicago House Wrecking Co.,
Chicago, Ill.

FIRMS
DEALING IN
WATER SUPPLY AND PLUMBING
MATERIALS

UNITED STATES

PUMPS

- The American Well Works, Aurora, Ill.
The Deming Company, Salem, Ohio.
The Goulds Manufacturing Co., Seneca Falls,
N. Y.
F. E. Myers & Bro., Ashland, Ohio.

WINDMILLS, PUMPS AND TANKS

- The Aermotor Co., Chicago, Ill.
W. E. Caldwell Co., Louisville, Ky.
Flint & Walling Manufacturing Co., Kendall-
ville, Ind.
Fairbanks Morse Co., Chicago, Ill.
Montgomery Ward & Co., Chicago, Ill.
Stover Manufacturing Co., Freeport, Ill.
Sears, Roebuck & Co., Chicago, Ill.

GASOLINE ENGINES

- Abenague Machine Works, Boston, Mass.
Detroit Engine Works, Detroit, Michigan.
Fairbanks Morse Co., Chicago, Ill.
Fuller & Johnson Mfg. Co., Madison, Wis.
Gilson Mfg. Co., Fort Washington, Wis.
The William Galloway Co., Waterloo, Iowa.
International Harvester Co., Chicago, Ill.
Kewanee Water Supply Co., Kewanee, Ill.
Lunt Moss Co., Boston, Mass.
Montgomery Ward & Co., Chicago, Ill.
Standard Pump and Engine Co., Cleveland,
Ohio.
Sears, Roebuck & Co., Chicago, Ill.
Sherman & Smith Co., Independence, Iowa.
Seager Engine Co., Lansing, Mich.
Weber Gas Engine Co., Kansas City, Mo.
The Waterloo Gasoline Engine Co., Waterloo,
Iowa.

HYDRAULIC RAMS

- The Goulds Manufacturing Co., Seneca Falls,
N. Y.
F. E. Myers & Bro., Ashland, Ohio.
Montgomery Ward & Co., Chicago, Ill.

Niagara Hydraulic Engine Co., New York City.

Power Specialty Co., New York City.

Rumsey Co., Ltd., Seneca Falls, N. Y.

Rife Engine Mfg. Co., New York.

Sears, Roebuck & Co., Chicago, Ill.

PNEUMATIC WATER SUPPLY

Abenague Machine Works, Boston, Mass.

Andrews Heating Co., Minneapolis, Minn.

C. A. Burton Water Supply Co., Kansas City, Mo.

Chicago House Wrecking Co., Chicago, Ill.

Fort Wayne Engineering & Mfg. Co., Fort Wayne, Ind.

Johnston Manufacturing Co., Kansas City, Mo.

Kewanee Water Supply Co., Kewanee, Ill.

Leader Iron Works, Decatur, Ill.

Lunt Moss Co., Boston, Mass.

Montgomery Ward & Co., Chicago, Ill.

Standard Pump & Engine Co., Cleveland, Ohio.

Sears, Roebuck & Co., Chicago, Ill.

HOT-AIR ENGINES

American Machine Co., Newark, Delaware.

Rider-Ericsson Engine Co., New York.

ELECTRIC PUMPING ENGINES

Fort Wayne Engineering & Mfg. Co., Fort
Wayne, Ind.

Fairbanks Morse Co., Chicago, Ill.

Jarvis Engine & Machine Works, Lansing,
Mich.

Kewanee Water Supply Co., Kewanee, Ill.

Leader Iron Works, Decatur, Ill.

AIR-LIFT PUMPS

American Well Works, Aurora, Ill.

Hudson Engineering Co., New York.

Ingersoll-Rand Co., New York.

WATER WHEELS

Jas. Leffel Co., Springfield, Ohio.

Pelton Water Wheel Co., New York.

WELL-DRILLING MACHINERY

Austin Manufacturing Co., Chicago, Ill.

American Well Works, Aurora, Ill.

PLUMBING

Andrews Heating Co., Minneapolis, Minn.
Chicago House Wrecking Co., Chicago, Ill.
B. Karol, Chicago, Ill.
Montgomery Ward & Co., Chicago, Ill.
Standard Sanitary Mfg. Co., Pittsburg, Pa.
Sears, Roebuck & Co., Chicago, Ill.

SEPTIC TANKS

Andrew Heating Co., Minneapolis, Minn.
Ashley House-Sewage Disposal Co., Morgan
Park, Ill.
Cameron Septic Tank Co., Chicago, Ill.
Modern Iron Works, Quincy, Ill.

CONCRETE

Atlas Portland Cement Co., New York.

CANADA

WINDMILLS, GASOLINE ENGINES, PUMPS, TANKS, ETC.

R. H. Buchanan & Co., Montreal, Que.
Canadian Fairbanks Co., Montreal, Que.
Robert Donaldson & Sons, Montreal, Que.
Gould Shapley & Muir Co., Brantford, Ont.

Ontario Wind Engine & Pump Co., Toronto,
Ont.

Paul Lair, Montreal, Que.

GASOLINE ENGINES, PUMPS, ETC.

Gilson Manufacturing Co., Guelph, Ont.

The Scott Machine Co., London, Ont.

PLUMBING

Thos. Robertson Co., Montreal, Que.

The James Robertson Co., Ltd., Montreal,
Que.

INDEX

A

- Acknowledgment, 257.
Air chamber, 91 et seq.; is absorbed, 143; lift pump, 112; pressure of, 72 et seq.; properties of, applied in pumps, 68 et seq.; weight of, 70 et seq.
Atmosphere, pressure of, 72 et seq.
Automatic regulators on windmills, 167; switches, 227; for open tanks, 228; closed tanks, 229.

B

- Bacterial action, 12, 34, 253.
Bathroom equipment, 245; prices of, 249.
Bath tubs, 246; prices of, 249.
Brooks, water from, 62, 63.

C

- Cap, drive, 48.
Cesspool, 251; tight, 252.
Centrifugal pump, 110.
Chain pump, 117.

- Cistern pump, 10; water, 65, 66.
Cylinders, deep well, 106.

D

- Dealers in water supply and plumbing equipment, 261 et seq.
Double acting ram, 188.
Drain, 10.
Drive cap, 48.
Drive points, 48.
Drive pipe of ram, 190.

E

- Electric motor, 221; and pump, 226, 227; advantages of, 227.
Electric switch, automatic, 227; for open tank, 228; for closed tank, 229.
Engine, Ericsson hot air, 193; gasoline, 204 et seq.; hot-air, 193; Niagara hydraulic, 185; Rider hot-air, 197; steam, 218.
Ericsson hot-air engine, 193; sectional view of, 194;

- working of, 194; cost of, 203.
 Experiments on air, 70 et seq.
- F
- Firms dealing in water supply and plumbing equipment, 261 et seq.
 Force pump, 17, 18, 89, 90, 97, 99, 101, 103, 104.
 Front, water, 21, 22.
- G
- Gallery near river or lake, 64.
 Gases, Kinetic Theory of, 153 et seq.
 Gasoline engine, 204; advantages of, 214; air cooled, 209; and pump, 211; cost of, 217; cost of running, 204; four cycle, 207; governor, 210; water cooled, 209; working of, 207.
 Governor, windmill, 166; of gasoline engine, 210.
 Gravity water supply, 120.
- H
- Hand power, 159.
 Hillside, well on, 61, 62, 120.
 Horse power, 159; of stream, 239.
 Hot-air engine, 193; Ericsson, 193, 194; cost of, 203; how to start, 201; Rider, 197; working of Ericsson, 194; Rider, 200.
 Hot water supply, 224.
 Hydraulic ram, 181 et seq.; at work, 182; double acting, 188; drive pipe of, 190; how regulated, 187; location of, 190; prices of, 191; sectional view of, 183, 186; sniffing valve, 184; standard, 183, 189; water lifted by, 185.
 Hydrostatic paradox, 151.
- I
- Impulse wheel, 235.
 Intake pipe, 62.
- J
- Jack, pump, 212.
- K
- Kinetic Theory of Gases, 153 et seq.; facts explained by, 155 et seq.
 Kitchen equipment, 8 et seq.; cistern water in, 10; running water in, 14; well water in, 16.
- L
- Lake, gallery near, 64; water from, 61, 63; well near, 64.
 Laundry tubs, 23; cost of, 24.
 Lift pump, 85.

M

- Methods of pumping, 159 et seq., 181 et seq., 193 et seq., 204 et seq., 221 et seq.
 Motor, electric, 221; and pump, 226, 227; advantages of, 229.

P

- Pipe, drive of ram, 190; intake, 62; prices of, 10, 16, 18, 22, 24.
 Plumbing, 8 et seq., 244, 247; precautions in installing, 248; materials, firms dealing in, 261 et seq.
 Pneumatic tank, 132 et seq.; excess pressure in, 141; height water is raised by, 138; windmill and, 177; system, advantages of, 144; cost of, 146; general view of, 133, 134; working of, 135.
 Points, drive, 48.
 Pressure, atmospheric, 72 et seq.; excess air, 141; of water at tap, 139.
 Prices, 10, 16, 18, 22, 24, 130, 131, 146, 180, 191.
 Pumping, methods of, 159 et seq., 181 et seq., 193 et seq., 204 et seq., 221 et seq.
 Pumps and their action, 84 et seq.
 Pumps, air-lift, 112; air chamber on, 91 et seq.;

branch pipe force, 101; centrifugal, 110; classes of, 84; chain, 117; double acting, 104; force, 17, 18, 89, 90, 97, 99, 101, 103, 104; house force, 97; how and why they work, 87; jack, 212; lift, 85; pitcher, 10, 96; rotary, 108; siphon force, 103; standard types of, 96 et seq.; well force, 99; lift, 98.

Q

- Quadrants, windmill, 176.

R

- Rain water, 27 et seq.; Nature's purifiers of, 34; separator, 66.
 Regulator, windmill, 167.
 Rider hot-air engine, 197 et seq.
 River, gallery near, 64; water from, 62, 63; well near, 64.
 Running water, 120 et seq., 132 et seq.; in kitchen, 16.

S

- Septic tank, 253.
 Sewage disposal, 12, 244, 250.
 Sink, 10, 11.
 Siphon, 147 et seq.; force pump, 103; uses of, 149.
 Springs, 58; protection of, 59; sources of water in, 31.

Steam engine, 228, 229.
 Storage tank, 17; windmill and, 174.
 Strata, impervious, 29; porous, 29.
 Switches, automatic, 229.

T

Tank, dimensions of, 123 et seq.; elevated, 120 et seq.; elevation of, 127; hot water, 21, 22, 244; location of, 127; septic, 253; storage, 17; and windmill, 174; supplied from eaves, 136; weight of when full, 126; prices of, 130.
 Taps, hot water, 21; prices of, 22, 23.
 Tubs, laundry, 23; cost of laundry, 24.
 Turbines, 237.

V

Valve, foot, 16.

W

Wash bowl, 246.
 Water, cistern, 65, 66.
 Water closet, 264; front, 21, 22, 244; from springs, brooks, rivers, and lakes, 58 et seq.; gravity supply, 120; gallons of, needed per

day, 122; lift, 233; lifted by hydraulic ram, 185; Nature's purifiers of, 34; power, 231 et seq.; on farm, 242; running, 120 et seq., 132 et seq.; sources of, in wells and springs, 31 et seq.; supply materials, dealers in, 261 et seq.; underground, 29; wheels, 233.
 Weight of air, 72 et seq.; water, 126, 127.
 Well, artesian, 33; drilled, 52 et seq.; driven, 44 et seq.; dug, 36 et seq.; errors in locating, 39; good dug, 40-42; how to know a poor dug, 37, 38; near river or lake, 64; on hillside, 61, 62, 120; poor dug, 36; sources of water in, 31; with pump in position, 36.
 Wheels, impulse, 235; water, 233.
 Windmill, 161 et seq.; and pneumatic tank, 177; and storage tank, 174; care of, 179; governor, 166; power of, 164; prices of, 180; quadrants, 176; regulator, 167; speed of, 162; tower, 171; cost of, 180.

Y

Y, lateral, 18.

