

LUBRICATION

8 JANUARY 1971 (Supersedes LO 5-2410-227-12, dtd 16 March 1970)

ORDER

TRACTOR, FULL TRACKED; D E D; 9900 LB. DRAWBAR PULL,  
 W/DOZER BLADE, BACK RIP SCARIFIER (J.I. CASE MODEL  
 M-450) AND LOADER, SCOOP-TYPE; W/FORK LIFT  
 ATTACHMENT (J.I. CASE MODEL M-450-L)  
 W/ENGINE CASE MODEL G188D

Reference: LO 5-2410-227-12-2 and C9100-IL

Intervals are based on normal hours of operation. Adjust to compensate for abnormal operation and severe conditions. During inactive periods, sufficient lubrication must be performed for adequate preservation.

Relubricate after washing.

Clean fitting before lubricating.

Clean parts with SOLVENT, dry-cleaning, or with OIL, fuel, Diesel. Dry before lubricating.

Lubricate points indicated by dotted arrow shaft on both sides of equipment.

A dotted circle indicates a drain below.

Drain crankcase and gearcase when hot. Fill and check level.

FOLD

FOLD

LUBRICANT ● INTERVAL

INTERVAL ● LUBRICANT

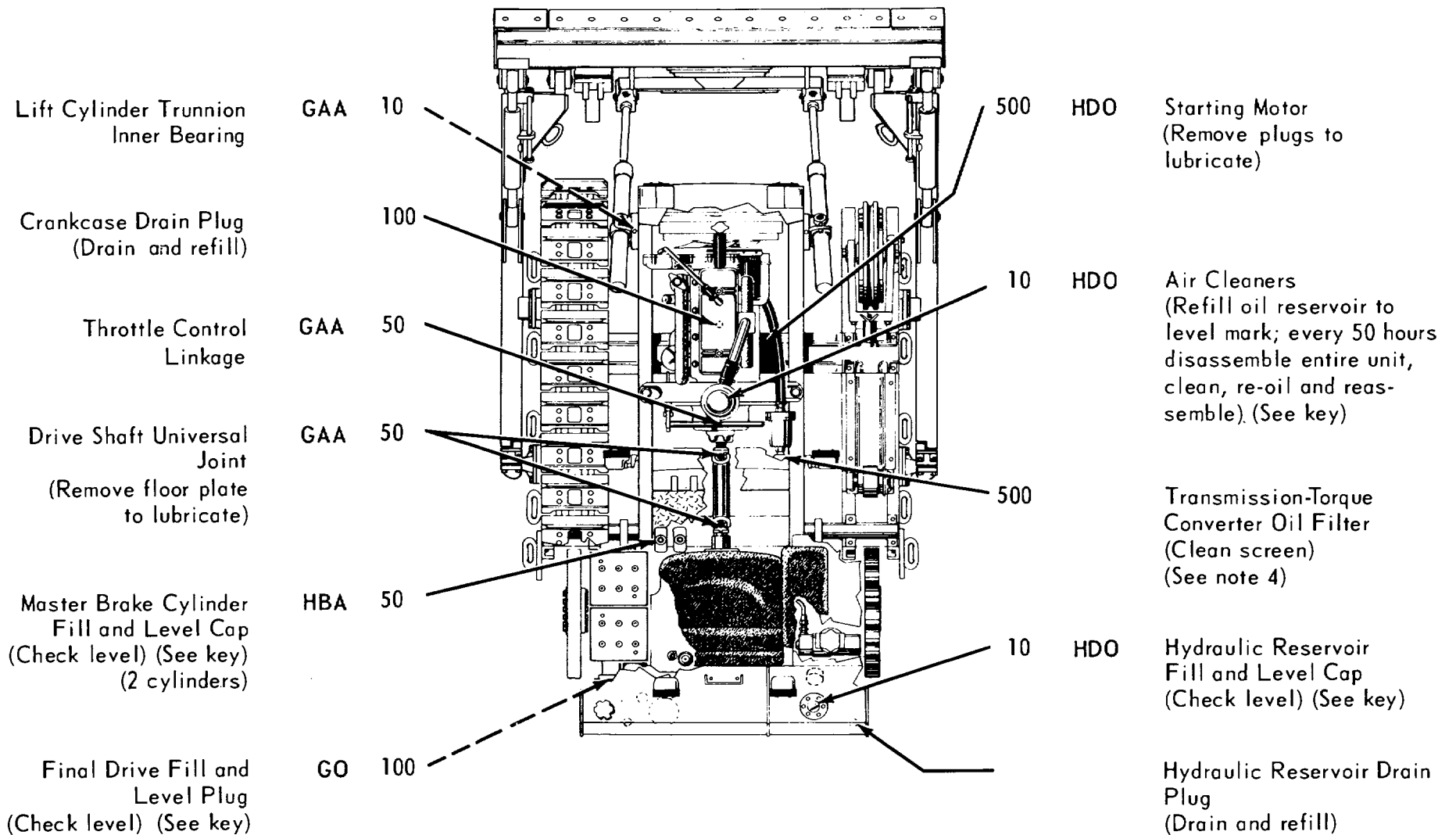

LUBRICANT ● INTERVAL

INTERVAL ● LUBRICANT

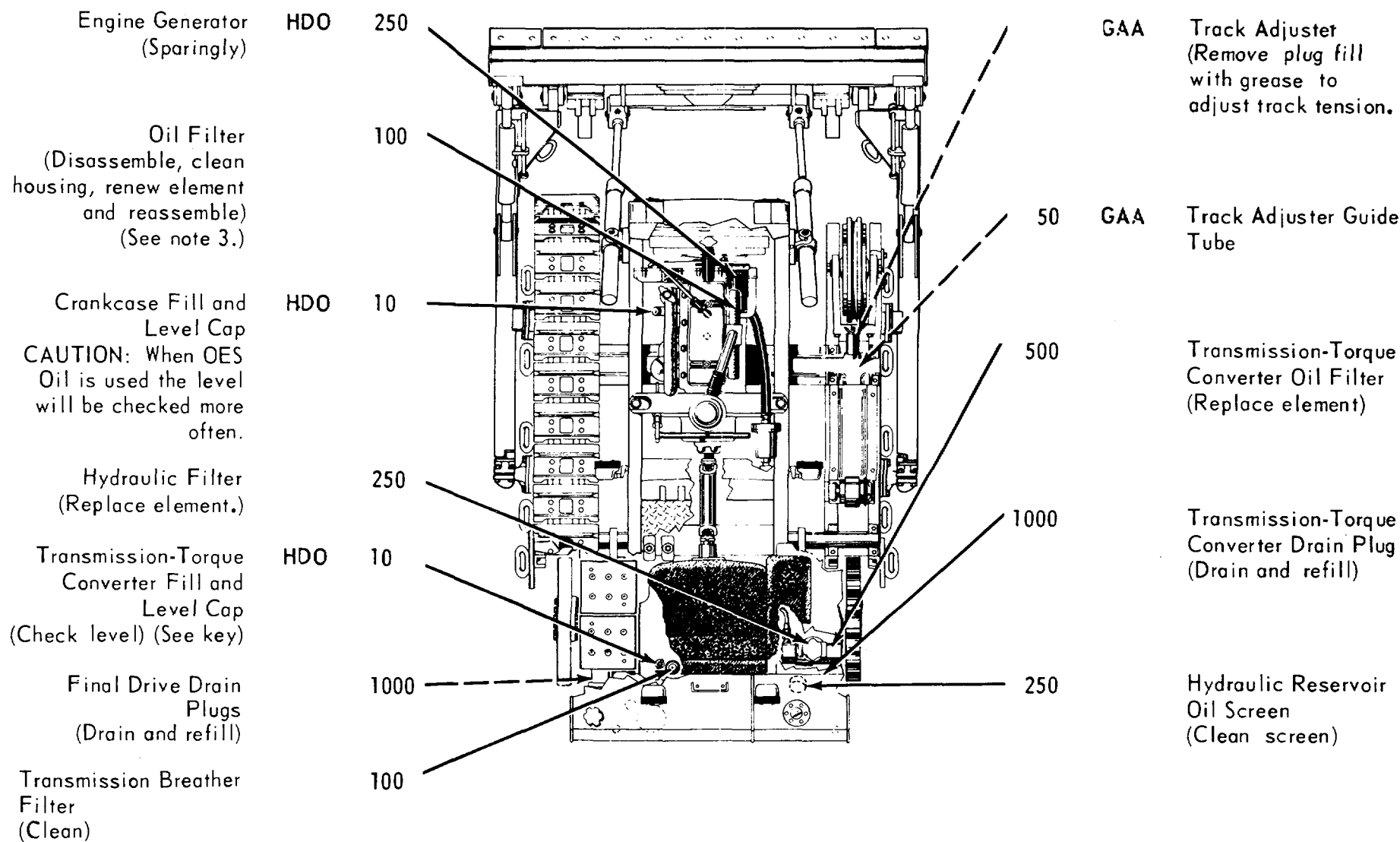

FOLD

FOLD

-KEY-

LUBRICANTS	CAPACITY	EXPECTED TEMPERATURES			INTERVALS
		Above +32°F	+ 40°F to -10° F	0°F to -65°F	
HDO-OIL, Engine, Heavy Duty					Intervals given are in hours of normal operation
Engine Crankcase W/Filter	7 qt	HDO 30	HDO 10	OES	
Air Cleaner	2-3/4 pt				
Torque Converter Transmission	32 qt				
Hydraulic Oil System Reservoir	30 qt	HDO 10	HDO 10		
Oil Can Points					
OES-OIL, Engine Sub-zero					
GO-LUBRICATING OIL, Gear,				GOS	
Final Drive	6 qt ea	GO 90	GO 90		
GOS-LUBRICATING OIL, Gear, Sub-zero					
HBA-BRAKE FLUID, Automotive		ALL TEMPERATURES			
Master Brake System	5/16 qt				
GAA-GREASE, Automotive and Artillery					

- NOTES:
- FOR OPERATION OF EQUIPMENT IN PROTRACTED COLD TEMPERATURES BELOW -10°F. Remove lubricants prescribed in the key for temperatures above -10°F. Relubricate with lubricants specified in the key for temperatures below -10°F.
  - OIL CAN POINTS. Every 50 hours lubricate control linkage, and all exposed adjusting threads with HDO.
  - ENGINE OIL FILTERS. Every 100 hours remove filter elements, clean housings, install new elements, fill crankcase, operate engine for 5 minutes, check for leaks, check crankcase oil level, and bring to full mark.
  - TRANSMISSION FILTER SCREEN. Remove and clean filter screen after initial 50 hours of operation, and every 500 hours thereafter.
  - LUBRICANTS. The following is a list of lubricants with the Military Symbols and applicable Specification numbers.
 

HDO MIL-L-45199	GO MIL-L-2105
OES MIL-L-10259	GOS MIL-L-10324
HBA MIL-H-13910	GAA MIL-G-10924
- Copy of this Lubrication Order will remain with the equipment at all times; instructions contained herein are mandatory.

BY ORDER OF THE SECRETARY OF THE ARMY:  
 W. C. WESTMORELAND  
 General, United States Army  
 Chief of Staff

OFFICIAL:  
 KENNETH G. WICKHAM  
 Major General, United States Army,  
 The Adjutant General.

LO 5-2410-227-12-1 DISTRIBUTION: To be distributed in accordance with DA Form 12-25, Section II, (qty rqr block #474) organizational maintenance requirements for Tractors, Tracked, Light.



This fine document...

Was brought to you by me:



## [Liberated Manuals -- free army and government manuals](#)

Why do I do it? I am tired of sleazy CD-ROM sellers, who take publicly available information, slap “watermarks” and other junk on it, and sell it. Those masters of search engine manipulation make sure that their sites that sell free information, come up first in search engines. They did not create it... They did not even scan it... Why should they get your money? Why are not letting you give those free manuals to your friends?

I am setting this document FREE. This document was made by the US Government and is NOT protected by Copyright. Feel free to share, republish, sell and so on.

I am not asking you for donations, fees or handouts. If you can, please provide a link to [liberatedmanuals.com](http://liberatedmanuals.com), so that free manuals come up first in search engines:

<A HREF=<http://www.liberatedmanuals.com/>>Free Military and Government Manuals</A>

– Sincerely  
Igor Chudov  
<http://igor.chudov.com/>