

WESTERN EDITION

LIBRARY
RECEIVED
APR 18 1910
U. S. Department of Agriculture

FARM AND FIRESIDE

THE NATIONAL FARM PAPER



ESTABLISHED
1877

APRIL 10
1910



An Unparalleled Offer From Farm and Fireside

A Letter to You From the Editors

FARM AND FIRESIDE wants to have more of your neighbors among its readers. You can help us to accomplish this, and we will pay you handsomely for your help. Our readers tell us that the new and greater FARM AND FIRESIDE has "made good." Thousands of our friends have written to us saying that FARM AND FIRESIDE is the best farm journal published at any price. We are glad of this because we have spared no money in making the best farm journal we know how to make.

Tell your neighbors what you think of the new and greater FARM AND FIRESIDE. Tell them about the Farmers' Lobby, and the big agricultural features. Tell them that the best farm writers contribute to FARM AND FIRESIDE. Tell them about the stories and pictures and household departments and patterns.

You can offer your neighbors an 8-month trial subscription for 25 cents.

Our Offer to You

Get two people each to give you 25 cents for an 8-month trial subscription to FARM AND FIRESIDE. Send us the 50 cents, and in return for the favor we will send you FARM AND FIRESIDE without cost for eight months after your present subscription expires. If you are not now a subscriber, your own subscription will be entered for eight months, without cost. In addition, the editors of FARM AND FIRESIDE will mail you a handsome present.

The present from the editors will be something unique, something that will please every member of your family. It will be sent to you absolutely without cost, in addition to the 8-month subscription to FARM AND FIRESIDE, in return for your sending us 50 cents for two 8-month trial subscriptions.

This offer is good for the next thirty days only. You should act at once. Write the names and addresses of your two friends and your own name and address on the coupon below and send to FARM AND FIRESIDE with 50 cents. You will receive FARM AND FIRESIDE for eight months, without cost, and will also receive the gift from the publishers.

Your Order Must Be Mailed Before May 10th

Use This Subscription Blank

This Gift Coupon

This coupon, if sent to FARM AND FIRESIDE before May 10th, together with two trial subscriptions at 25 cents each, will entitle you to a

Beautiful Gift

from the editors, in addition to an 8-month subscription to FARM AND FIRESIDE.

Farm and Fireside, Springfield, Ohio.

Dear Mr. Editor:—I send you herewith two 8-month trial subscriptions to FARM AND FIRESIDE at 25 cents each. I inclose 50 cents in payment for the same.

Please extend (or enter) my own subscription to FARM AND FIRESIDE for eight months, and send me, in addition, without cost, the Editors' Gift. (If you are now a subscriber, the 8-month subscription will be added to your present subscription.)

Your Own Name _____

Address _____

Write below the addresses of the two new subscribers:

Name _____

Address _____

Name _____

Address _____

(If you do not wish to cut this page, write your order on a piece of paper. You will receive the Editors' Gift just the same.)

Your Last Chance to get 5 Elegant Rose Bushes Absolutely Without Cost



Will Bloom This Season of 1910

THESE rose and other flower collections were grown especially for FARM AND FIRESIDE by one of the greatest nurseries in America, and now offered by FARM AND FIRESIDE without cost to its friends in order to add 100,000 new readers. FARM AND FIRESIDE guarantees that these plants will bloom this season of 1910.

Five Best Roses

(Order as No. 101)

1. **Climbing Meteor**—The brightest colored of all roses and a persistent bloomer.
2. **Mrs. Ben R. Cant**—Deep red and one of the hardest and finest varieties.
3. **Mlle. Franzisca Kruger**—Deep yellow—unique and distinct from all others.
4. **White Maman Cochet**—Snow white, tinged with the faintest suggestion of blush.
5. **Etoile de Lyon**—One of the hardiest and most beautiful yellow tea roses.

See our liberal offers below.

Five Fragrant Carnations

(Order as No. 103)

1. **Prosperity**—The largest Carnation ever offered.
2. **Rose Pink Enchantress**—One of the most famous varieties.
3. **Red Sport**—The showiest variety of Carnation ever grown. Color a flaming scarlet.
4. **Harlowarden**—A bright dazzling crimson. The largest and best of its color.
5. **Lady Bountiful**—Pure white, sweetly scented with the delightful old-fashioned clove fragrance. See our liberal offers below.

Four Elegant Ferns Three Splendid Hydrangeas

(Order as No. 104)

Of all plants for pot or interior decoration, ferns occupy the place of favor. The most popular and successful American ferns are very large and pure. This collection consists of the leading snow-white color. Blooms from early June varieties—**Boston, Emerald, Fountain** and through August. Perfectly hardy. Three **Asparagus**. See our liberal offers below. sturdy plants. See our liberal offers below.

To Get the Flowers

Send us only TWO 8-month subscriptions to FARM AND FIRESIDE at the special price of 25 cents each, and we will send you, without cost, any one collection of flowers offered on this page. The subscriptions may be new or renewal. One of the subscriptions may be your own. Tell your friends that an 8-month subscription to FARM AND FIRESIDE at 25 cents is a bargain that they can only get through you.

To Get More Plants

For THREE 8-month subscriptions to FARM AND FIRESIDE at 25 cents each, we will send you any two collections of flowers; for FOUR 8-month subscriptions at 25 cents each we will send you any three collections of flowers. We will send an additional collection of flowers for each additional 25-cent subscription you send us.

Send Your Order Before May 10th

Cultural Directions

Collections must be ordered entire. Accompanying each lot of plants are full directions for rooted, and will bloom the coming season planting, care, etc. Every flower collection will be sent carefully packed, with delivery charges prepaid by FARM AND FIRESIDE, and will be sent to any address you designate. We guarantee them to be exactly as described, to arrive in perfect condition, and to give entire satisfaction or your money cheerfully refunded.

SEND ALL ORDERS TO FARM AND FIRESIDE, - Springfield, Ohio

WARM AND FIRESIDE



Vol. XXXIII. No. 13

Springfield, Ohio, April 10, 1910

PUBLISHED
SEMI-MONTHLY

Tuberculosis on the Farm

By Dr. Mazÿck P. Ravenel



Dr. M. P. Ravenel

Doctor Ravenel is the head of the bacteriological department of the University of Wisconsin. His fame as an authority on tuberculosis, however, is not limited to a state, nor to this country. His papers have been features of all the late international congresses on tuberculosis. Next fall he will be one of this country's delegates to the congress of alimentary hygiene in Belgium. Doctor Ravenel was the first to locate the germ of bovine tuberculosis in the human system. What he has to say can be taken as the final word of scientific enlightenment on the subject of the great white plague and the fight against it.

EDITOR.

I ALWAYS feel some hesitation in speaking to practical farmers. I find quite wide-spread among them the idea that men like myself, who spend most of our time in the laboratory, are very apt to be carried away with what they consider book-learning and theories, but are deficient in practical knowledge. A little story may illustrate that sometimes, at least, such an opinion is wrong.

I once gave an address before an audience of farmers. At the close a farmer old enough to be my grandfather got up and said, "That's a pretty nice talk you have given us and I expect you think you are a pretty smart young man, but I don't believe you know as much as you think you do. Can you look at a bunch of calves and pick out the ones that will make the best milch-cows?" "Certainly I can," I said. "The heifer-calves every time." This turned the laugh on the old man, so I said, "You have started to ask me questions, I will make a proposition to you. We will ask each other questions, and the first man who asks the other a question which he himself cannot answer must set up cigars for the crowd."

He agreed quite readily. So I said, "Can you tell me how it is that a ground-squirrel can dig a hole and not leave any dirt around the top?" "I don't know. Why is it?" said he.

"It starts in at the bottom and digs up," I answered. "How does it get to the bottom?" said the old man. "I have never been able to find out," said I. "That's your question."

This ended the guying for the day. The subject on which I am writing is one of enormous practical importance.

Tuberculosis, which we ordinarily see in the form of consumption, is the greatest scourge which afflicts the human race to-day, and has been well called "the great white plague." Its victims number at least one hundred and fifty thousand in the United States each year. This means four hundred deaths occur each day. We are in the habit of rating the sanitary civilization of a community by the death-rate from typhoid fever, because it is a preventable disease and because it is conveyed most often by what all of us must use every day of our lives—namely, water. It is not unfair to apply the same method of reasoning to tuberculosis. Judged by this standard, we have much to learn and accomplish before we can face criticism on this point. What I have said would have no point were it not for the great fact that tuberculosis is a disease, the cause of which we know, and therefore is a preventable malady. Again and again let us insist on the question, "If it is

preventable, why is it not prevented?" Let every one ask himself this question and, further, see if he himself is doing his full duty in the prevention and eradication of this great scourge.

The cause of the disease is a small germ belonging to the lowest class of vegetable life. It belongs to the fungi. It was discovered by Robert Koch in 1882 in human beings and in animals. It can be made to grow on artificially-prepared soils which we make up in our laboratories. At first we used the watery part of the blood, which was coagulated by heat, but now we have succeeded in inventing quite a number of artificial soils on which it will grow readily and luxuriantly. It is, however, one of these germs which prefer the body of some warm-blooded animal for its home, and there is no evidence that it ever increases in nature outside of the body of men or animals. When thrown out in the expectation or from diseased organs, it does not multiply at all and sooner or later loses its life through the action of the elements. Sunlight is especially destructive to it. If exposed without any covering, sunlight will kill the germ in a few minutes, and as ordinarily thrown out in the expectation of consump-

tions and the air about them. The-germ is also found in their slobber, and the habit which cows have of licking each other's noses and faces passes the disease from one to the other. The bulk of the material which is coughed up by the cow from the lungs is, however, swallowed, and passes through the intestinal tract to be discharged with the feces. In this way the whole stable may become infected with the germ. Calves which are suckled by tuberculous mothers may become diseased in the ways just described, but also by the germs passing into the milk of the mother. The milk carries them into the digestive tract of the calf, and they pass from the intestine into the blood and soon reach the lung, where they lodge and produce disease.

Tuberculosis is often introduced into a herd through the by-products of creameries. For example, a creamery may serve one hundred patrons, ninety-eight or ninety-nine of whom perhaps have perfectly healthy herds. One or two may have consumptive cattle. When the patron who has only healthy cows takes away his skim-milk, he does not get the healthy milk which he delivered to the creamery, but a mixed product which may contain the milk from the one or two

patrons with consumptive cattle. In feeding this milk to his cattle or swine, he introduces tuberculosis on his farm. Another very frequent way in which tuberculosis is introduced into a healthy herd is by purchase. In Wisconsin in 1908 it was shown that of three hundred and sixty-three herds found to be infected with tuberculosis, two hundred and sixty-three had been infected in this way. The lesson is obvious. Never introduce new cattle into a herd without being sure that they are free from tuberculosis. In other words, purchases should always be made, where possible, subject to the tuberculin test.

Tuberculosis seems to be spreading with alarming rapidity among the swine in many states and in many other parts of the world. In the majority of cases it is apparently spread by the use of creamery by-products as above described, and, in view of the enormous losses in this way, laws have been passed in some countries requiring the sterilization of these products. Only two states, Iowa and Minnesota, have such laws in this country. Another fertile source of infection of swine is the droppings of tuberculous cattle. As mentioned above, cattle which they have raised from their lungs, and this is discharged with their evacuations. Hogs following cattle and feeding on this material contract tuberculosis very readily. There is not much evidence that hogs transmit the disease from one animal to the other.

The appearance of a cow does not at all indicate the extent to which she may be dangerous to the rest of the herd. In cattle, as in man, we find that the disease progresses with varying degrees of rapidity, depending upon various factors, some of which we do not understand. In general, however, it may be said that if a cow is well fed and well cared for, the disease will not show its ravages as rapidly as in an animal not so well treated. This condition is exactly what we find in the finest dairy herds, and an animal apparently in the most perfect health may be retained in a herd for years, all the time spreading the disease to other members of the herd. This has been well illustrated by a number of cases. At the University of Wisconsin a cow known to have tuberculosis was kept under observation for six years, all the while retaining her sleek and healthy appearance. The point which must

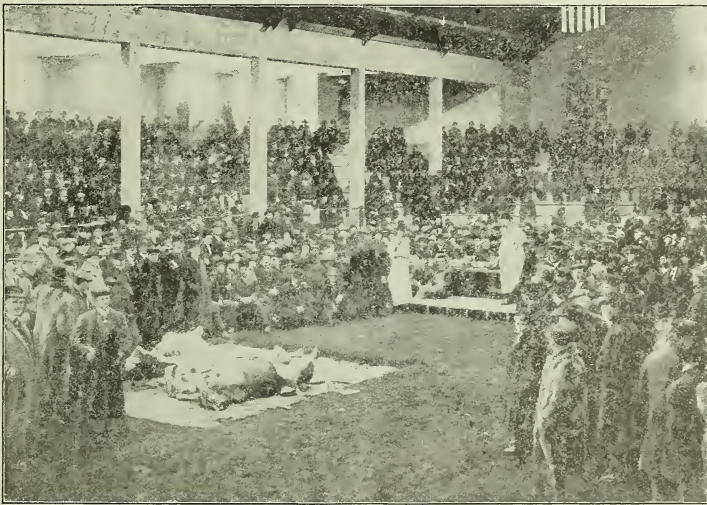

Showing Farmers Tuberculosis

Post-Mortem on Tuberculin-Tested Cattle at the University of Wisconsin Farmers' Course, February, 1910

tives, it will always lose its life in direct sunshine within forty-eight hours. The number of germs thrown up by a single person in twenty-four hours, however, reaches into the billions, and this is the chief source of danger to well people—the expectation of consumptives. Here then we have at once seen the chief method of prevention of the disease—the destruction of all material raised from the lungs of consumptives.

The disease in animals bears a close resemblance in many ways to the disease in mankind. It is spread in the same way, and it can be said with the utmost certainty that no case of tuberculosis ever arises spontaneously. Every case of tuberculosis comes from some previous case, whether it occurs in man or in animals. Tuberculosis in cattle is a matter of tremendous economic importance. If a single animal with the disease is introduced into a herd, it will sooner or later inevitably infect all the other animals with which it comes in contact. There are several ways in which this takes place. While cows do not spit in the ordinary sense after coughing, as human beings do, it has been shown that during coughing they throw out a considerable amount of spit which is rich in tubercle germs. In this way they infect the feed-boxes and

[CONCLUDED ON PAGE 19]

How Western Canada Inspects Her Grain

Where Organization Gives the Farmer Strength—By Arthur Hawkes

In our last issue Mr. Streeter showed in detail what an evil system of grain inspection American growers suffer under. What are we going to do about it? We might do worse than to take our cue, in this matter, from our cousins across the boundary. Canada's grain gets impartial government inspection; furthermore, her growers are so well organized that, when the system appears to work with over-severity, they can exert an effective check on it. This great cooperative Grain Growers movement will be the subject of another article by Mr. Hawkes in the near future. EDITOR.

THE advocates of state interference in private transactions may find a justification in the government inspection of grain in western Canada. A strict individualist might argue that the producer must sell his commodity in the best market he can reach and that the state has nothing to do with trade except to punish those found guilty of fraud.

But the state exists for more than the mulcting of the criminal. There are such things as freedom and justice, and the business of the state in a free country is to see that individuals do not oppress their fellow-men out of their rights. What is oppression? The answer is as long as the question is short.

Take one aspect of public and private right—that of taxation. You remember a glorious and immortal war for the recognition of this blessed article of political faith—that there must be no taxation without representation. There are other ways of taxing besides that of sending the demand note of a county whose managing body the tax-payer helps to elect. The tariff is one of them. Indeed, it is the most powerful weapon of government on this continent.

The national revenue is largely raised by the tariff. When you pay a dollar for a piece of woolen goods that the British manufacturer, if there were no tariff, could send you for seventy-five cents, you are paying your share of the expenses of the nation. It is the peculiar distinction of the tariff that, under its lee, there have been built many colossal fortunes whose real origin would have

been essentially the same if the possessors of them had sent around a demand on county paper, backed by all the force of state and federal law.

There is a line beyond which it is not right for one man's cunning against another man's industry to go. The trouble of defining that line is what makes real political differences, and creates commercial "interests" in the body politic. It is the need for such a line that puts all kinds of expedients on the statute book, designed to defend the honest against the dishonest, and to protect the unduly covetous against themselves.

This is good for the individual, the locality and for the nation in its collective capacity as trader. For success in trade depends very much on reputation; and if the nation, through the necessity for protecting the weak, did not legislate for honesty in trade, the crooked men who care no more for the nation than they do for their neighbor would soon plunge the greatest, purest nation in the world into disastrous disrepute. For nothing is truer than that honesty is the best policy, and that a few rogues, if they are left alone, will soon destroy a whole people.

See how this works out in the matter of selling grain for export. If there were no stringent law providing for uniformity, every smart, short-sighted fellow in the grain business in Winnipeg would be trying to pass off inferior grain as the very best; and, through the multiplicity of cars and the variety of tricks, there would be a confusion that would ruin the reputation of western Canada in the Old World. The sense of honor, the claims of fair play, which are so lacking in some men, have to be furnished for them by the community, sometimes with the aid of a turnkey. That is the meaning of government inspection of grain that is leaving western Canada for the mills of the East and of Europe.

How is it done? The system of inspection is governed by Dominion legislation corresponding to legislation emanating from Washington, as distinct from state legislation. The "Manitoba

Grain Act" sets up the machinery, which works well, on the whole, as a part of the Department of Trade and Commerce. The act established a Grain Standards Board of twenty-three members representative of Eastern and Western grain interests, two of the former and twenty-one of the latter. The Chief Grain Inspector, the Grain Inspector, and Warehouse Commissioner are ex-officio members of the board.

The act established a Survey Board of twelve members—three each being nominated by the Departments of Agriculture of the provinces of Manitoba, Saskatchewan and Alberta, and three by the Winnipeg Board of Trade. The Standards Board fixes the samples of the various grades, to which the deputy inspectors work. The Survey Board is the growers' court of appeal, when complaint against a grading is made.

Often as much as five-hundred-thousand-dollars worth of grain is inspected at Winnipeg daily and, although the process of grading is simple, the inspectors must necessarily be experts, for they are to the grain trade what the taster is to the wholesale tea business. As soon as a train of grain cars arrives in Winnipeg, seven samples of grain are taken from various parts of each car, mixed together, and a bag holding two and a half pounds is filled with the mixture. The car is resealed, the sampling taking just about two minutes. When the train has been sampled, the bags are sent to the Chief Inspector in the Grain Exchange Building. His assistants, working in a locked room, divide the bags into groups with only their car numbers to identify them, so that the deputy inspectors do not know who shipped or who will receive the grain.

The sample bag is opened and a pound of its contents poured into the weighing pan of scales which are marked to weigh only one pound and are graded into a hundred sections to give percentages. The grain is then put into a standard sieve of ten meshes to the inch and when the waste has passed through it is weighed again, the percentage of waste noted and the dockage set accord-

ingly. The sample is next submitted to a close scrutiny, examined for color, etc., and the grade fixed. The assistant can verify the grade which he has assigned the sample, by either weighing a quart (each grade has its fixed weight per bushel) or by comparing with the standard samples which are at his hand.

When the grade has been finally fixed, the sample is poured into small tin boxes to protect from mice, stored and filed. It is customary to hold these samples for a month. When all chance of a demand by the grower for reinspection has passed, they are dumped together and sold, the money going to the Dominion Treasury.

The Grain-Growers' Associations of western Canada—organizations of farmers, for business and mutual defense—became dissatisfied with what they held to be an unnecessary tendency to degrade their grain, compared with former standards. They knew that their wheat was the best in the world and was sure to hold its own with millers. But if wheat that at one time was called Number One Hard should become known as Number Two Northern, they said, the farmer would surely be at a disadvantage. So, when they sent a delegation to Ottawa to put the Dominion wise on the grain situation generally, they asked the Minister of Trade and Commerce to allow them to take samples alongside the government officers. "Certainly," said Sir Richard Cartwright, "if you can fix it with the other people."

Some difficulty was met with here, which was only to be expected. But it was finally arranged that the grain-growers should have a man to accompany the government samplers, watch the sampling of cars consigned to the Grain-Growers' Grain Co.—the selling end of the association—and secure a sample to be inspected at their office where an expert inspector fixes a grade and dockage. As the Grain-Growers' Grain Co. is now the largest grain firm in western Canada, the concession is worth a great deal, and will no doubt be succeeded by others.

The San Jose Scale

Are We Holding Our Own Against It?—By N. T. Frame

IF THAT question were asked in court, where a yes or no answer was demanded, I should have to look to my lawyer to object to the form of the question. But assuming the question to be put by a fruit-grower seeking my opinion, and one who pronounces the name San-ho-zay, proving that he has been accustomed to attend horticultural society meetings and is somewhat familiar with this insect, I am free to answer, "I think so."

There are probably a dozen counties in the Southern states where peaches have been grown commercially that will lose thousands of trees this year from San Jose scale. The climatic conditions are favorable to the breeding of the insect practically throughout the year, which fact, coupled with the evident infestation of hook-worm in some of the owners, has meant defeat in the fight against scale in these orchards; but in these counties, as elsewhere, the personal equation is a big factor. Other owners who have properly sprayed their trees two and three times yearly have fine orchards, practically free from scale.

Enlightenment spreads slowly, and in every county, North and South, many trees are sure to be killed by the scale because their owners are not commercial fruit-growers, do not know that the trees are infested with scale and have no equipment with which to spray, even if they know of the infestation.

Having made these admissions and fully realizing the seriousness of the pest, I base my optimistic reply on these facts:

First: Private letters from prominent fruit-growers in nearly every commercial fruit section in the country state that thorough spraying once (in some sections twice) yearly enables them to keep the scale completely in check.

Second: Nine out of ten of the speakers at the various state horticultural society meetings refer to the San Jose scale as a blessing, in that it has

forced the adoption of such spraying methods and of such general orchard practices as have materially improved the orchards and the fruit.

Third: The nurserymen all tell us that, in spite of their more than usual preparation, the demands for nursery stock this year much exceed their supply, and that a large part of the stock sold is for commercial planting. Surely fruit-growers, whose livelihood depends on their orchards, are not planting millions of acres in fruit unless they have confidence, born of experience, in their ability to control the San Jose scale successfully.

The general attitude of nearly all parties in interest makes me even more optimistic for the future. In New England, New York, New Jersey, Maryland, Virginia, Georgia, Ohio, Illinois, Michigan, where the fight against the scale has been going on for some years, the experiment station officials, as well as the large growers, now lay stress on the fact that successful spraying against the scale is very largely a mechanical problem. The kind of spray does not matter so much, so long as it hits the insect. There are thousands of competent fruit-men who use nothing but soluble oil year after year just as there are thousands who use nothing but commercial lime-sulphur, and still more thousands who will not try anything but home-made lime-sulphur. Such successes are due to the fact that every one of these men "put the spray on right." Those growers who have not been so



San Jose Scale on Bark of Fruit-Tree
(Magnified)

successful, who have been accustomed to blame the spray mixtures and change yearly to some new brand are now being urged to look to their method of application for the cause of their failure, rather than to the spray used. This sign, in my judgment, points in the right direction.

In other states, like Arkansas, Kansas, Iowa and Wisconsin, the activity of the authorities against the scale promises to limit

the fight in those states to much narrower sections than would have been the case had the scale obtained its foothold there some years earlier.

The present studious attitude, regarding the scale, of those who have never before been forced to fight it is in contrast to the mental panics which formerly caused otherwise sane men to sacrifice to the axe trees that could easily have been saved by treatment. Nowadays a man who has reason to suspect scale on his trees sends a branch that he believes infested to his state experiment station for examination, and asks for literature and advice. But he also generally realizes the value of having a check on the advice of one official and so he writes for bulletins from other states where comprehensive field experiments have been reported—like Bulletin on San Jose Scale of the Rhode Island Station, Kingston, Rhode Island; Bulletin No. 4 of the West Virginia Station, Morgantown, West Virginia; Bulletin No. 76 of the Tennessee Station, Knoxville, Tennessee; Bulletin No. 18 of the Missouri Station, Mountain Grove, Mis-

souri. At the same time he writes to manufacturers for their literature on commercial spray materials and spray pumps.

If it proves true that he has the scale, he buys a good pump, one guaranteed to maintain at the nozzles a pressure of over one hundred pounds, selects the kind of spray material which appears to fit in best with his local conditions and his other farm work, and the scale never becomes a serious problem to him because it never gets a substantial foothold.

Reinforcements which have come into the fight against the scale, but are sometimes not fully appreciated, are the manufacturers of spray materials and pumps. Many of these firms, spend thousands of dollars annually sending well-trained field men into individual orchards to hunt the scale and show the owner how to successfully control it. In every section are growers who take no stock in horticultural papers, or societies or even in experiment stations. Their infested orchards are a constant source of reinfestation to all the orchards around them. But many of these men each year become subject to the logical arguments of spray-pump men who are salesmen and understand human nature. They buy equipment and spray their orchards, to the very material benefit of the whole community. The continual and increasingly successful "hammering" of this kind against hard-shell orchardists by the dealers promises well for the future.

When the nurserymen were all denying the existence of scale in their nurseries and avoiding, so far as possible, proper fumigation or dipping methods, a great number of young trees were planted already infested with scale. But the frank attitude of most of the leading nurserymen at the present time, who admit their liability to scale, but take every possible precaution, by spraying the nursery rows with weak soap or oil

Mastery Over the Horse

How to Cure Some Common Vices—By David Buffum

Did you ever think that the horse has a mind quite like your own, differing "in degree, but not in kind?" A good horseman knows the mind of the horse and takes advantage of his knowledge to gain the mastery. A well-broken horse is one that recognizes man's supremacy. This article tells some of the ways in which you can impress that supremacy upon him. EDITOR.

IN ALL training of horses—whether breaking to harness, the cure of bad habits or teaching the tricks of the circus—the first essential is to understand the nature of the horse. For all scientific training is based upon certain features in the horse's mental make-up, and without a knowledge of these features no great success can be made. With it you can do things that the majority of those who use horses cannot do. And yet there is no magic in good horsemanship. It is an art, to be studied and learned like any other art. And although, as in other things, those who have the most natural aptitude for it can become the most proficient, yet its principles are simple and can be mastered by any one.

It was stated by Darwin many years ago that the minds of animals do not differ from those of men in kind, but only in degree, and this is so evident that I do not think any intelligent man, who has had much experience with horses, can doubt it for a moment. The horse has the same emotions as man—love, hate, fear, jealousy, and so on—and his reasoning faculties work in the same way, but subject always to the limitations implied by the law already stated, that they do differ, and differ a great deal, in degree. Hence, as we would naturally expect, the horse reasons a great deal more from experience and a great deal less from observation than man does. Indeed, horses that reason from observation, to any noteworthy extent, are rare.

A very familiar evidence of this limitation is seen in the halter-breaking of colts. The little colt, when first tied up, is tied by a halter that he cannot possibly break, and (reasoning wholly from this experience and in nowise from what he observes) it does not thereafter occur to him that he can break away, even if tied by a rope that he could snap like a thread. By the same principle he is taught the needed lessons in docility and obedience in other respects. But suppose that some time, when a little restive and tied by a weak halter, he does break his halter-rope. If he fully realizes what he has done, he will try the same thing again, even if tied with a rope strong enough to hold a ship.

It is in this way that bad habits are formed. The well-broken horse is kind because, whenever he attempted to do as he pleased, he found his master's will superior to his own. He learns a vice because, on some unfortunate occasion, he discovered that in at least that one particular he could do as he pleased after all and that his master was powerless to prevent it. He repeats the vice because, having committed it once with impunity, he feels all confidence that he can do so again. In the cure he must be met on his own ground and the matter reasoned out, by arguments that he cannot fail to understand, till he owns himself mistaken. To do this—to make a vicious horse unlearn the dangerous knowledge of his own power—will, manifestly, require different and more radical measures than are needed to check the colt in his first disposition to go wrong.

Your Will Against the Horse's Will

As the horse, in the practise of any vice, shows a rank disregard of his driver, the first step in its cure is to impress him, in a general way, with your supremacy and his own inability to successfully resist you. This you can never do by means of the whip or club. Whipping a horse punishes him, it is true, but it is powerless to compel him to do what you want and it also rouses his resentment in a way that makes his training all the more difficult. Remember that the first thing you are striving for is his complete subjection, that nothing can be done till this is accomplished and that it must be accomplished, not by punishment, but by a display of power. Furthermore, to succeed you must be very patient as well as persevering, always remembering that you are dealing with an intelligence inferior to your own and exemplifying the grand old Arab proverb "Fear and anger a good horseman never shows."

Copyright, 1910, by David Buffum.

In the treatment for kicking, the disposition to kick should, as far as possible, be taken out of the horse before he is harnessed. It is best to begin by laying him down a few times. A horse lying prone upon the ground is robbed of all his natural means of defense, and the knowledge that you can, at your pleasure, place him in this humble and defenseless position has a very chastening effect on his mind.

Having first selected a smooth piece of greensward where he will not hurt himself, put on him a bridle and surcingle and strap up his near forefoot

When the horse has lain on the ground for a few minutes—long enough, say, for his brains to settle a bit—release the straps and let him get up. Then repeat the operation and keep on till he ceases to make much resistance and shows, by his altered demeanor, that he has lost confidence in himself. He is now ready to harness. In this proceed as follows:

Have ready a strap one and one half inches wide and eight inches long, with a ring sewed strongly into each end. Attach this firmly to the top of the bridle, so that the rings hang just over the rosettes. Have an extra bit (a

the least as long as he behaves. When it is finally left off, have a check-rein made on exactly the same principle and adjust it so as to keep his head at the same height.

The device here described—which, for want of a better name, I call the "controller"—I first used some twenty years ago on an exceptionally bad runaway kicker, after having used several other contrivances which did not have quite the desired effect. I have since found it one of the very best means of control and correction, and I have used it with excellent results in the cure of other vices as well as kicking.

The Kicking Habit is Curable

Kicking is very properly classed as one of the very worst of vices and yet I have not known a case that could not be cured. All that is necessary is to apply the right treatment and to apply it intelligently and perseveringly. Some cases require much longer treatment than others, however, and it is impossible to state how long it will take to cure any particular case. One filly, for instance, that came to me with an evil record took over three months of patient training before her disposition to kick was wholly eliminated. On the other hand, I once bought a four-year-old colt that had become a kicker when being broken and was considered so bad that his breaker gave up the job, yet a fortnight's treatment was all that was needed to render him perfectly safe and gentle. Many times—indeed, generally—the tendency to kick is, in a large measure, cured at the very beginning of treatment. But the horse must still be used with his rigging on and watched carefully for a recurrence of the vice, and he cannot be considered cured till a convincingly long period of good conduct, without even a hint of his vice, indicates that his reformation is permanent.

For running away, unless accompanied by some other vice, simply put on the controller and bring the horse to a stand still whenever he attempts to run. The discovery that you have it in your power to stop him will have a very salutary effect upon him and it will not be long before his attempts to run will be much less frequent. The controller should be kept on him till he has gone long enough without showing any disposition to run to indicate that the habit is cured. This may take some time, but the treatment, to be effective, must be thorough, and, as already pointed out, the device does no harm and is not in the driver's way. When you finally do discontinue it, use a four-ring bit with over-draw check-rein and continue to use it as long as you have the horse. He may never run again, but safety should be your motto and there is no bit so good for holding a horse. It has also the great advantage of being an easy bit for the horse as long as he does not pull upon it—and this is a noteworthy feature, as you can never cure a vice or a bad habit if your means of correction is operative at other times than when the vice is exhibited.

I have purchased and used quite a number of runaway horses and have never had much trouble with them. Sometimes the inclination to run would show itself a little at intervals, and, more frequently, it seemed to become wholly eliminated. But in the use of horses on the road there is often more to rearouse this vice than some others and I would repeat my recommendation that the use of the four-ring bit and over-draw check-rein be never discontinued on a runaway.

Some Good in a Balker

Balking is not a dangerous vice but, of all equine short comings, it is perhaps the most intensely aggravating. And yet the old proverb that "there is always good stuff in a balky horse" has some truth in it. For horses of superabundant nervous energy are the kind that are by far the most likely to contract this vice. Dull, sluggish horses are not so subject to it.

Balky horses, though all exhibiting the same vice, are of such different kinds—each one, apparently, having a different kink in his head—that it is impossible to tell, in the first place, which one of several kinds of treatment will work best. But there are so many cases in which palliative treatment is all that is needed that this should always be given a fair trial before coercive measures are used. Use the horse horse-fashion and take his good conduct for granted and very often he will forget to

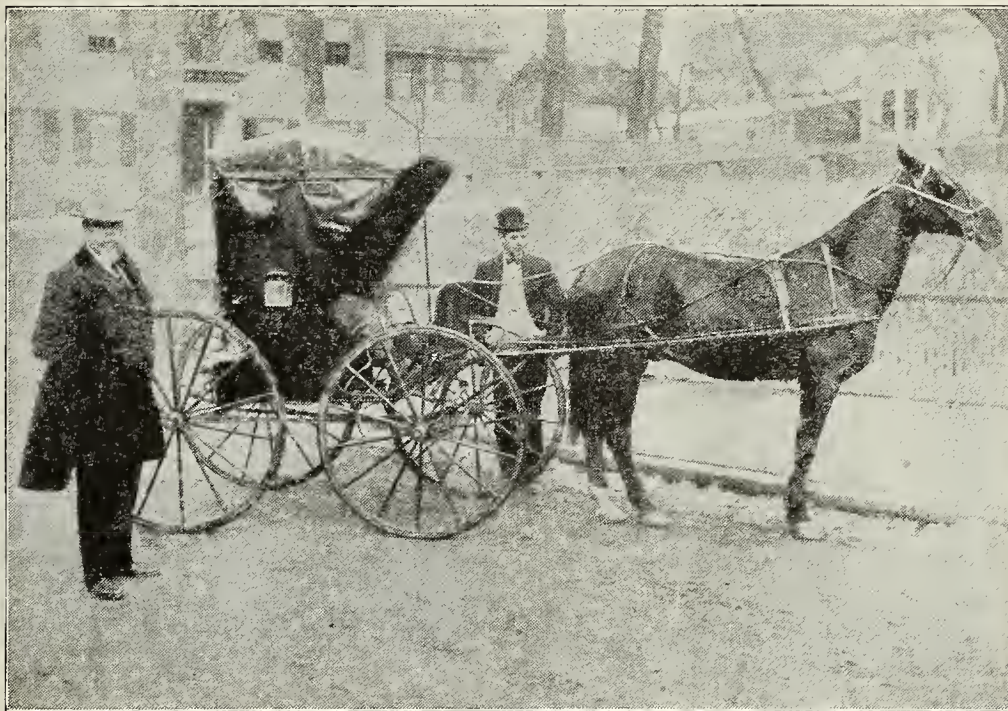

Showing the Controller When it is Hanging Slack—It Does Not Irritate the Horse, But Acts Simply as an Over-Draw Check-Rein

with a breeching-strap—the short loop around his foot, between hoof and fetlock, and the long one over the upper part of his leg. Fasten one end of a long strap to the off forefoot below the fetlock, pass the other end up through the surcingle and take it in your right hand, the bridle-rein being in your left. Push the horse sidewise and the moment he steps, pull sharply on the strap. This will bring him to his knees. If he is a horse of any spirit, he will generally make a valiant fight against this treatment, often springing high and plunging

straight one, not jointed) in your horse's mouth. Now take a strong cotton cord about as large as the little finger and, having one end in the breaking-cart, carry the other end forward through the off terret, up through the off ring on your short strap, down through the off ring of the extra bit, over the horse's nose, though near ring of extra bit, up through near ring on short strap, back through near terret and there tie to the long end, so as to form a check-rein. Adjust this so as to keep the head at the proper elevation, rather low than



The Way the Controller Acts When Pressure is Applied. The Horse is Unable to Kick or Plunge

desperately; but, having the use of only his two hind legs, he soon becomes wearied and rests with his knees on the ground. Now pull his head toward you and he will fall over the other way. By simply holding down his head, you can keep him on the ground as long as you please.

Simple as all this sounds, the trainer needs his wits about him and must be alert of foot and eye, as well as hand. Sometimes, with a really bad horse, it takes some little time even to get the straps adjusted and the foot fastened up, and if the horse is large and strong, the trainer should have an assistant, the latter holding the horse's head by a long rein attached to the bridle, while the trainer handles only the foot-strap.

high, but not too low. Tie a string from the top of bridle down between the eyes to the cord where it goes over the nose, so that it will not slip down.

Now, whenever the horse attempts to kick, pull sharply on the line and his nose will be twitched up in the air, rendering kicking impossible, for he cannot kick when his nose is sufficiently elevated. It also has a fine moral effect on him that is very consoling to those who have seen him kick a buggy or two to pieces. The arrangement should be used till the horse shows no disposition whatever to kick and in this it is best to err on the side of safety, giving him time for the most thorough repentance. The cord is not at all in the driver's way and it does not hurt or irritate the horse in

balk. When he does, try to fool him by saying, "Whoa," get out and adjust the harness or pick up his feet, one after another, as if looking for a lodged stone and finally hammer on one of them with a stone, keeping it in your hand long enough to thoroughly take his attention and perhaps weary his other leg a little. Then get into the buggy as if everything were all right and start him up in the usual way.

All this may work and it may not, but it is the first thing to try. I have had a great many balky horses and in quite a number of instances have applied no further remedy and have used them for years with no repetition of the vice.

But if palliative treatment is found insufficient, put on the controller and elevate the horse's nose whenever he stops. Hold it up strongly for a few seconds, then release the pressure and he will generally start.

Should it be necessary to treat the horse still further, proceed as follows:

Take the horse out of the shafts, strip off all of his harness and put on an ordinary halter. Tie the hair of his tail into a hard knot. Now run the halter-ropes through the hair above the knot, pulling his head well round toward his tail and fasten by a half-turn and loop which can be undone by a single jerk. Now stand back from the horse, touch him behind with your whip and he will begin to turn around in a circle. He will presently get very dizzy and, if not interfered with, will fall down. It is better not to go to this extreme, how-

ever, as, in falling, he may injure himself; watch him sharply and the moment he is thoroughly dizzy untie the rope. Now harness him as quickly as possible, put him in the shafts—and drive on. I have not often found it necessary to whirl the horse in this way more than once to make him start, but in some rare instances it has to be repeated; in such cases make him turn the other way.

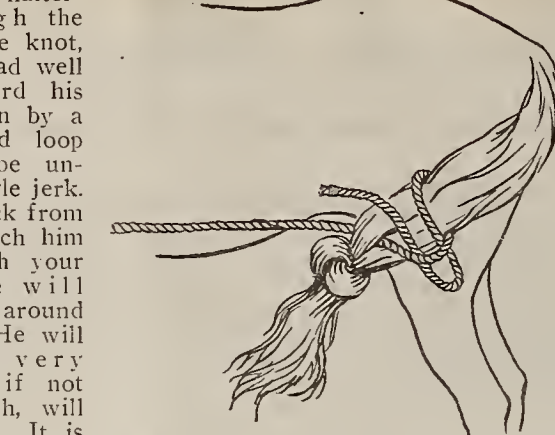

Safest Hitch in Tying Head to Tail

ever, as, in falling, he may injure himself; watch him sharply and the moment he is thoroughly dizzy untie the rope. Now harness him as quickly as possible, put him in the shafts—and drive on. I have not often found it necessary to whirl the horse in this way more than once to make him start, but in some rare instances it has to be repeated; in such cases make him turn the other way.

One point in respect to the whirling treatment can hardly be over-emphasized—it is essential to use a hitch that can be released instantly when the horse shows signs of tottering. If a knot is used that makes quick release impossible,

ease. After that recognition of your supremacy he has little inclination to defy you and, if always handled quietly and with no display of temper or irritability, will soon come to yield the cheerful and unquestioning obedience that is so essential.

There are very few horses that will not amply repay the time and trouble necessary to cure them of their vices; in many cases it is making a useful and valuable animal of one that was formerly worthless. But the wise horseman will always bear it in mind that prevention is better than cure, for, although accidents will sometimes happen even with the best of management, the great

majority of horses that have vices would never have contracted them if handled rightly from the first.

Many bad habits are formed when the horse is newly broken and beginning to work. It is then that he is getting his ideas of what he can and cannot do, and double vigilance is necessary to see that he does not make experiments in independence, that will lead to vice. Too often, the young horse is trusted too much, he is left standing, tied with a weak hitch-ropes or perhaps without hitching at all, used by inexperienced drivers or may be driven in an old ram-shackle wagon, with an old harness tied together with strings. Vice can almost always be traced to bad management of some kind. It is a good while before a young horse is fit to be used and trusted like an old one, and if this fact could be constantly borne in mind by those who use him, the proportion of accidents that happen and vices that are formed would be much less.

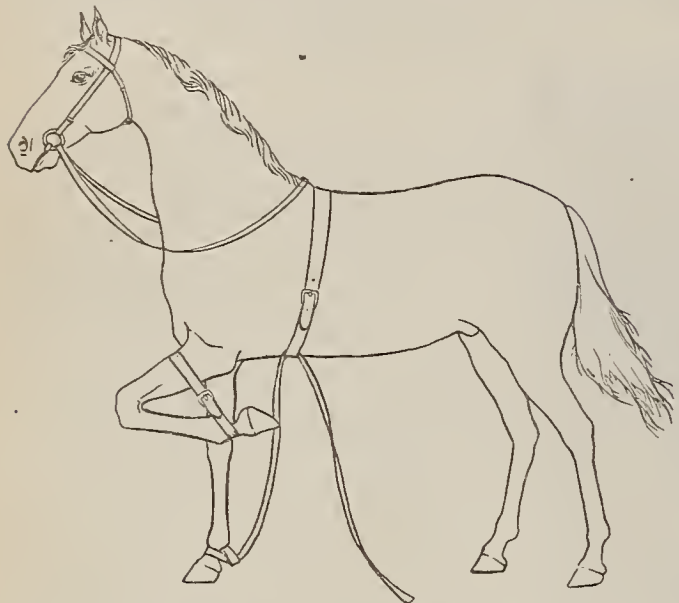

Straps Used in Throwing a Horse

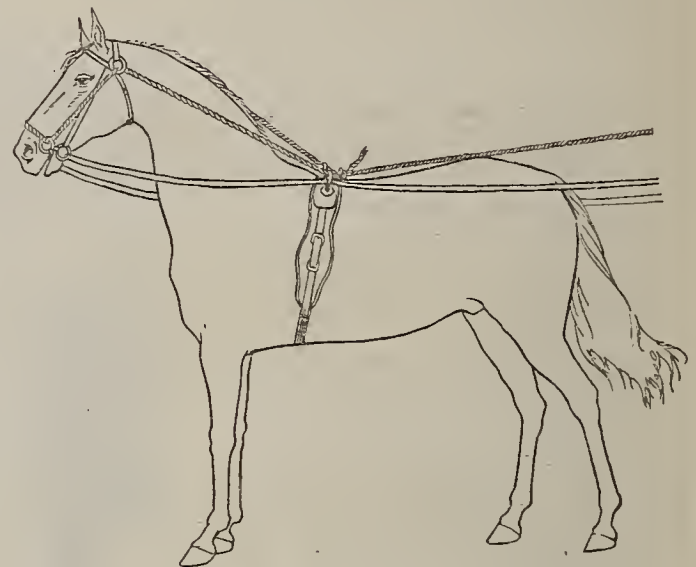

Showing Details of the Controller

The Knack of It

Handy Ways of Doing Things Around the Farm

Here are some handy schemes tried out by Farm and Fireside folks on their own farms. To most of our readers, we believe, they will be new; to a great many they will be helpful. If you have a way of doing or making some particular thing that is better than the common way, why not write us about it and let us pass the idea along? We will pay for all letters that we use, of course. EDITOR.

Cleaning Up a Disk

WE HAVE a handy plan for cleaning a disk. It takes two to do the work, but it can be done in fifteen minutes. Raise the disk off the ground. If the disk has a solid tongue without joint, a small buck can be put under the tongue and the whole machine lifted by levering on the tongue. It can be held off the ground by a couple of pieces of two-by-six with a piece of two-by-four nailed under them, to keep them from tipping. Put a crank over the nut at

ways pieces, completing the trough. A pair of two-by-fours are then nailed crossways on each end for legs, on the saw-buck plan.

This kind of a trough always has one clean side. If wet or stale feed gathers in one side, the whole thing can be turned over, the dirty trough dumped and the other one brought into play.

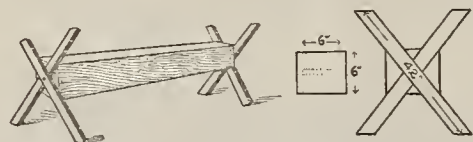

When it is not in use, turn it up edge-ways and both sides keep dry.

Let pieces about forty-two inches long bring the box to about the right height for a sheep. Their length can be suited to the height you want. W. F. BROCK.

A Time-Saving Hay-Stacker

FOR a foundation for your hay-stacker select two sills (the pieces running from right to left in the diagram) twelve feet long and twelve or fourteen inches in diameter. Slope both ends of each sill underneath so it can be pulled either way. Lay heavy planks ten feet long across between the ends of the sills and spike them. Spike down another plank connecting the centers of the sills. This center plank should be at least three inches thick, as the whole weight of the center pole rests on it. A still stronger scheme is to use another sill instead of this center plank. This latter scheme is followed in the diagram. This completes the foundation. Then select a straight pole twenty-three feet long and six or seven inches in diameter at the top, and put an iron band on each end to keep it from splitting. Bore a three-fourths-inch hole in the bottom of the pole and drive an iron pin in tight. This pin should project an inch or two and fits into a hole in the center plank. Next get four poles eighteen and one half feet long and four inches thick for braces; bolt them to each corner of the foundation and to the center pole six feet from the top. It is a good plan to spike a piece of heavy plank about ten inches wide and two feet long upright on each outside corner of the foundation. The four braces can then be bolted to these pieces.

Get a pole eighteen feet long and four inches in diameter for the cross-pole on top. Bolt this into the iron socket that goes into top of center pole. For this

socket I use a piece of one-and-one-fourth-inch pipe about eight inches long, having two straps of iron eight inches long, half an inch thick and one inch wide welded on one end and made in clevis shape, as shown in the diagram. This clevis part should be four inches wide and four inches deep, with holes drilled through the upright straps so a bolt can be run through the cross-pole on top. The cross-pole should extend five feet on one side and thirteen feet on the other. Bolt a brace to a short end of cross-pole which should reach to center pole six feet below the top. Place another brace on the opposite side in like manner. Run another piece from the middle of the brace to end of cross-pole. Four-by-four stuff is good for these braces. Have a ring made in two pieces as diagrammed. Put this around center pole six feet below top and bolt to braces. This ring should fit nicely, but not tight, as this ring turns on the pole. Also the socket on top turns, being set loosely into a hole in the top of the center pole. This allows the cross-pole to revolve in any direction.

Get three pulleys, fasten one to each end of cross-pole and one to corner of foundation. Thread the pulleys with seventy feet of three-fourths-inch rope,

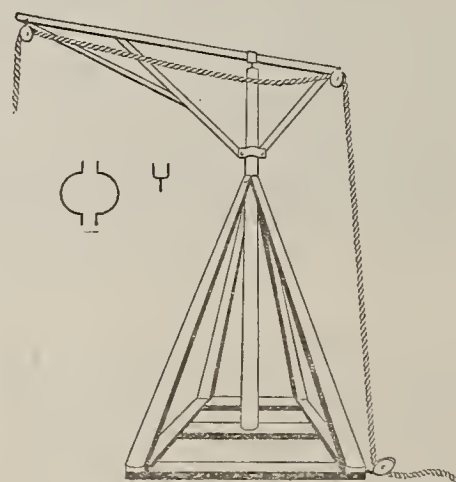

and fasten a harpoon hay-fork to one end and a single-tree on the other. Fasten one end of a sixty-foot trip-rope to the hay-fork and the other end to the long end of the cross-pole; the operator can then pull the cross-pole back after swinging it over the stack.

Always pull the load of hay up on the same side of the stacker that the lower pulley is attached to. This throws the rope, between the lower pulley and the

short end of the cross-piece, at an angle, and when the hay leaves the wagon, the horse pulling on the rope swings it round onto the stack. If you wish to make two stacks without moving, change the lower pulley to the opposite corner. Three persons can operate this stacker. A good team can move it easily. I have used this stacker two seasons with success. Most farmers have a scrap-pile where the necessary iron and bolts could be had at little cost. B. J. RAVER.

A Cure for Damp Cellars

OUR cellar was certainly damp. Everything in it used to be covered with a coat of mold. This is the way we went about curing the difficulty:



The walls had been cemented and made tight, but the bottom was dirt and constantly damp. We dug out the bottom about three inches deep next the wall and gradually sloped it toward the center, making the excavation about fourteen inches deep at that point; in the center we dug a hole about three feet deep and wide, and filled it with gravel, covering at the same time the entire bottom with gravel to the depth of about three inches at the walls and twelve at the center, leaving the center about two inches lower than the sides after tamping heavily until the gravel showed a smooth surface. A piece of tile twelve inches long was stood in the middle of the center hole; the upper end of the tile being flush with the top of the gravel and covered with galvanized screen. We then mixed Portland cement with sand in proportions of one of cement to three of sand, mixed thin enough to pour. This we poured on the gravel about one inch thick and tamped it until it made a solid mass with the gravel. We then troweled the top smooth. That floor gave us a perfectly dry cellar, and we can scrub it out with a broom any time we wish, the tile taking the water. It took less than five bags of cement for a cellar fourteen by fifteen.

We are convinced there is no use of having a damp cellar unless water rises in it at times, when it should be properly drained by tile. W. H. SHAY.

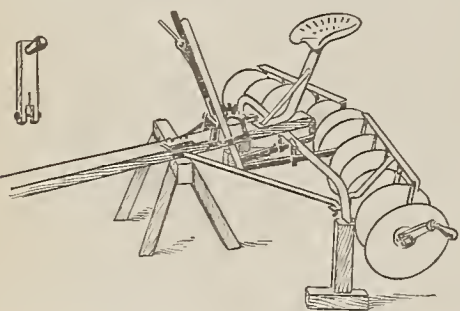

the end of the disk. A buggy-wrench can be used, or if you have none that fits make a wooden handle as shown in the small sketch, with the end sawed out to fit over the nut. Put a small bolt across the jaw of the handle to tighten it over the nut. One does the turning and the other holds an old wet broom against the revolving disks until they are clean. When they are dry hold an old paint-brush dipped in oil against the disks and revolve them. Then you leave your disk in as good shape as when it was new. H. F. N.

A Reversible Sheep Trough

A "DOUBLE-FACED" trough like that shown in the diagram is a fine thing in feeding sheep in the lot. Two one-inch boards six or eight inches wide and about four feet long are nailed to the edges of another inch board of the same length and width, so that looked at from the end they form a letter H. Boards are nailed on across the ends of the length-

How to Go About Draining

By W. Milton Kelly

TO RAISE good crops during unfavorable years, we must control the essential conditions of tillage, fertility, seed and moisture. Tillage, fertilizers and good seed are within the reach of all farmers. But moisture—there's the question. The man who owns a farm that is low and too wet for profitable crop growing, finds himself practically helpless, unless he has the capital to invest in underdrainage.

Putting in a complete system of tile drainage is a big proposition. In many instances it requires an investment of from thirty to forty dollars to the acre or more than the land is worth after the system is completed. We must view

amount of fall of the main line of tile and whether or not you are going to extend the system so that a larger main line would serve the purpose for two fields. After determining upon the size and number of tile needed for the main line and laterals, write to a number of tile manufacturers and get their lowest figures for the grade of tile you want in car-load lots f. o. b. at your nearest station. In this way you can save the dealer's profit, which is a big item.

For an eight or ten acre field, where very little water from higher land settles, a five-inch main tile line will carry the water off rapidly enough to prevent injury to the crops. For the twelve or

of us can afford to wait five or ten years for results. On forty acres of our vineyard the drainage system was installed about twenty years ago and it is doing better work to-day than it did for the first ten years after it was put in. The soil is a heavy clay and the tiles were laid from three to four feet deep.

Loafing acres can be made to return a profit by the judicious expenditure of a small amount of time and money for tile drainage. In fact, tile drainage is one of the best and most profitable investments a farmer can make, but, like all other good investments, it has to be managed intelligently to give results.

Ditching for Tile

IN LAYING drain tile the digging is usually done at the time of year when no real dependence can be placed in the weather. Hence a ditch when once commenced should be finished as soon as possible.

A simple and inexpensive, as well as a labor and time saving, way to start the ditch, after marking out the line it is to follow, is to hitch a team to the breaking-plow, and plow a furrow from eight to ten inches deep along the line. Then plow the other way beside this furrow, throwing the dirt in the opposite direction. This will make a furrow from eighteen to twenty-four inches wide. Next plow a furrow through the middle of this large one, making it deep as possible. In this way from sixteen to twenty inches of hard spading is saved, which you can easily figure means a big saving on a long ditch.

M. E. GEORGE.

Two Questions

M. F. T., Morris, Illinois—Soy beans can be planted with a corn-planter that has a wide adjustment in the drop. You can also plant them with an ordinary grain-drill. Cover up part of the holes in the hopper, so that the beans will be planted in drills about thirty-three inches apart. They can then be cultivated with a one-horse cultivator. Or you may be able to adjust your grain-drill to a different width that will be more suitable to your implements of cultivation.

The best ensilage is made by cutting up the corn and fodder together. You cannot husk the ears and then make good ensilage of the stalks. The right time to fill the silo is just when the corn is ripe enough for putting in the shock. Of course, that is too early for husking off the ears. Sometimes, where sweet corn is raised for a cannery, the roasting-ears are jerked off and sold, and the stalks are cut up and put into a silo.

J. C. B.



One Reason for Tile Drainage—Flooded Places Mean Not Only Waste Land, But Waste of Labor in Cultivating Around Them

tile drainage with the same business sagacity that we would any other farm investment. The trained business man with limited capital seeks investments which are safe and bring rapid returns. Unless we can secure similar results we should not invest in tile drainage.

The field that is fairly productive, that contains a few wet acres that delay plowing, planting and cultivating the whole field each year, causing a setback in the work of the farm, should receive our first attention. By draining those wet portions of the field, the yield will be increased, without the same cost of tillage and seed. By trying out the work on a few wet acres, we can find

fifteen acre field a six-inch main should be used. Keep in mind the fact that the main lines should be large enough to carry still more water if we should desire to extend the system to other parts of the farm. A well-planned system of tile drainage should be as permanent and enduring as the land itself. Where it is necessary to utilize open ditches for the outlets, great care should be exercised to prevent them from filling so that the water might rise above the level of the drain tile that flow into them.

The mains should be laid a number of inches lower than the laterals, to afford ample fall. The larger-size tile for the mains can be ordered with any desired size of hole to join onto the laterals. Every joint should be closely fitted to prevent dirt getting into the tile; the water will find its way through the closest joint you make. For laterals I would use the three-inch round tile. The smaller sizes might give equally good service, but the actual difference in the cost is so small that I would prefer to pay it, rather than to assume the risk of the smaller tile becoming displaced or filled with silt.

In a climate where there is danger of freezing, I would buy only the hard-burned tile. The soft tile absorbs large amounts of water and has a tendency to crumble when subjected to even a small amount of freezing. On the other hand, the hard tile absorbs very little water and is no more injured by freezing than ordinary stone. The water does not enter the soft tile through the walls, but through the joints, so the impervious character of the hard tile is no objection to its use. Farmers should give special attention to this point of durability and use only the best tile. Have the dealers or manufacturers submit samples and insist upon your order being up to the standard of the samples. When we invest money in drainage we want the work to last.

In determining the depth to lay the tile we must carefully consider the type of soil and the fall of the land. On a coarse-textured soil of loose silt, sand and gravel, where the object of the drainage system is to remove the water from around the plant roots, I would lay the tile three or four feet deep, but on a fine clay soil I believe that the tile should be laid as shallow as is consistent with the climatic conditions and the fall of the land; for on clay soil the chief object is to remove the surface water as rapidly as possible after every rain to prevent it injuring the crop, and to do this the water must have easy access to the tile.

On a clay soil it requires a number of years for a tile drainage system to become efficient if it is laid too deep. Few

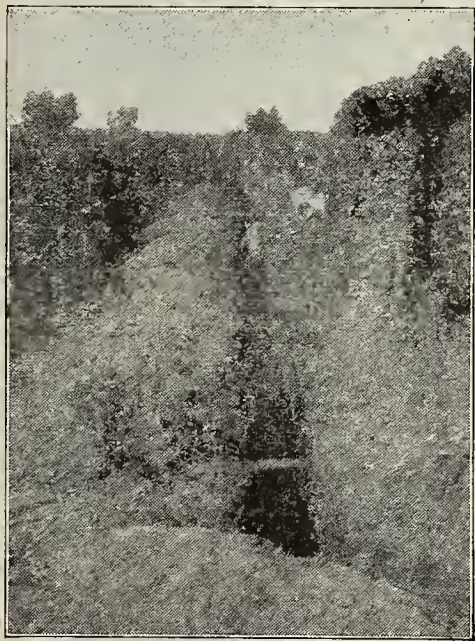

Laying a Main While Crops Are on the Ground

out what tile drainage is worth in increasing the productiveness of our farms and be prepared to do more intelligent work in laying new systems and making extensions to our first work. We are not all in a position to put in a complete system of tile drainage the first year, but we can plan our work so that what we are able to do from time to time shall not be haphazard and disconnected, but shall fit nicely into the previously-worked-out system and form a permanent part of it.

Use a surveyor's level and a tape-line in making out the plans of your drainage system. Never trust the eye or any present impression that the water can be carried off in one direction as easily as in another. Always seek the outlet that will cause the least trouble. Study the size of the field and the quantity of water to be removed. Consider the

Keep Your Buildings Well Painted

An application of Carter Pure White Lead paint will insure your buildings against decay. Carter forms a tough, elastic film that never cracks or scales—only years of wear will remove it.

CARTER

Strictly Pure

White Lead

"The Lead With the Spread"

is the most durable paint made. It excels in *whiteness*, beauty of finish and spreading qualities. The extreme whiteness of Carter assures strong, true, brilliant and durable colors—remember this.

Measured by square yards of surface covered and years of wear, Carter is the most economical paint you can buy. Sold by all reliable dealers. Request your painter to use Carter.

Send today for our valuable free book, which tells how to test paint for purity; how to choose a harmonious color scheme, and gives many other helpful suggestions. We send with the book a set of beautiful colored plates—suggestions for painting your buildings.



"To Be Sure It's Pure, Look for CARTER on the Keg."

Carter White Lead Co.

12051 So. Peoria St., Chicago, Ill. (17)

Factories: Chicago—Omaha



THE AUTOMOBILE FOR THE UPTO-DATE FARMER

\$1250 Complete with Remy High Tension Magneto, Generator, gas and oil lamps, tire repair and tool kit, and horn; 107 in. wheel base.

The "Regal 30" has 3 years of success behind it. It is the car that has demonstrated the simplicity, style, hardhood, durability and speed that others claim. The first car of its style and power to be sold for \$1,250.

Costs least to operate. Always ready to go. It is the ideal family car for the progressive American farmer as well as for his city cousin. Write TODAY for literature and information.

Regal Motor Car Co.

Beaubien and Piquette Aves., Detroit, Mich. Licensed under the Selden Patent



"Excuse me I know what I want and I want what I asked for Kellogg's TOASTED CORN FLAKES"

The name—Kellogg's—and the signature are protected by the laws of the U. S.

The flavor and goodness are equally impossible of imitation.

The original corn flakes is Kellogg's—imitated but never equalled—deliciously flavored—appetizingly crisped—wonderfully wholesome—Insist on the genuine for your own protection.

The Original Corn Flakes—the Kind with the Flavor—always bears this Signature. None other is Genuine

Made of the Best White Corn Only



W. K. Kellogg

UP HILL & DOWN



See That Knot

Anthony Fence

Is made with line wires of EXACTLY the same length. On the level—uphill—downhill, Anthony fence "sets right". The stays are upright, parallel with the posts—the tension of erection is put evenly on the entire fence. This means not only a HANDSOMER fence, but a more DURABLE fence. There is no straining of one wire and slacking on another.

The Anthony knot requires no kink in the line wire to hold it firmly. No pull can loosen or expand this knot. Extremes of heat and cold do not affect it. It is the tightest and most compact knot ever devised. It is small, yet strong, because made from the same size wire as the line wires.

NO HILL TOO STEEP—NO GULLY TOO DEEP

The tough, spring steel wire is highly galvanized and is inspected BEFORE, DURING and AFTER the process of weaving it into Anthony fence. The Anthony Fence machines do not injure the galvanizing and our triple inspection maintains this high standard of careful exactness and perfect uniformity. That's why we confidently claim it is "The Best Fence on Earth" and ask you to inspect and test sample for yourself. Write us today.

The Anthony Fence Co. 80 Michigan Street, Tecumseh, Mich., U. S. A.



P & O Canton Disc Cultivators

The highest type of Disc Cultivator yet produced—free from useless and complicated parts. It is simple and strong, like all P. & O. implements. Telescope axle, 42 in. wheels, dust-proof oil cups. Draft bars on a single pivot, giving a wide swing.

The gangs can be set in or out, and given any desired pitch. Discs held in ground by springs. Hard maple bearings, oil-soaked. Convenient oil tubes, plugged to keep out dust.

Five implements at the Cost of One Frame and Attachments.

Can be furnished with attachments so that it can be used as a Disc Harrow, as a Shovel Cultivator, or with Shovels and Discs combined, as a Spring Tooth Cultivator, or with a Front Arm Attachment for throwing the soil in or out. Made with Rigid or Pivot Tongue.

Has every necessary convenience and adjustment for close work. The best known Disc Cultivator made.

Insist on getting P. & O. goods from your dealer. Write for Catalog K99 We will also mail free a Beautifully Illustrated Pamphlet. Write Today.

Parlin & Orendorff Co., Canton, Ill.

"Pennsylvania" Quality Lawn Mowers stay sharp because they have crucible tool steel blades

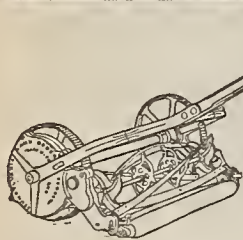

THESE blades are hardened and tempered in oil. They are self sharpening—always in the best cutting condition from the time the mower leaves the factory till the lower blade is ground flat. The "Pennsylvania" is the only mower in which all blades are of crucible tool steel.

It has a train of gears giving a wide wheel base which means increased power and speed. Highest grade material and workmanship throughout.

With a "Pennsylvania" the first cost is the only cost. Thousands of Pennsylvania Lawn Mowers in use a quarter of a century and more without repairs, prove their working and lasting qualities. Our book—"The Lawn—Its Making and Care," was written by a well-known authority. Sent free upon request.

SUPPLEE HARDWARE COMPANY, Box 1580, Philadelphia

Write for Price and Guaranty on This ACME Pulverizing Harrow, Clod Crusher and Leveler

For many years the favorite because it is "the harrow of all work"—the only implement a man needs for following the plow in any field—or stirring any kind of soil.

It Crushes, Cuts, Lifts, Turns, Smooths and Levels in One Operation

Yet it puts less strain on the horses than any other harrow, owing to the sharp, sloping knives. The knives cut through the sod or stubble turned under by the plow, leaving the trash below the surface, while other harrows drag this to the top, where its fertilizing value is wasted.

Also Best For Covering Seed. The curving coulters turn every inch of the soil. Made in different sizes, from 3 feet to 17½ feet in width.

Examine the Acme at your dealers. Ask for our new Free Catalog, containing also valuable articles on preparation of the soil.

Mfd. by **DUANE H. NASH (Incorporated), 127 Central Ave., Millington, N. J.**

Lowest Priced Riding Harrow Lightest Draft

FREE

Our new catalog contains articles by experts on "Preparation of the Soil," meaning larger and better crops for you. Write postal now.

Fruit-Growing

By Samuel B. Green

Stir the Orchard Soil

A FRUIT-GROWER at Yakima, Washington, wants to know about cultivating orchards. Almost every kind of orchard is benefited by cultivating throughout the growing season. The best way to do this is to plow lightly in the spring to the depth of perhaps four inches and then keep the land well dragged throughout the season, or use a disk harrow or orchard cultivator. The advantage of having a loose cover of dirt on orchard land is not generally enough appreciated. It acts like a mulch in preventing the ground from drying out and is especially important in dry seasons, and in the dry districts it is absolutely necessary for success. Where orchards are grown on steep hillsides, as is frequently the case, it may be out of the question to cultivate them as is here recommended, on account of washing. In such a case, the washing may occasionally be prevented by cultivating in such a way that the water will run off on a gradual slope along the hillside. To do this to best advantage, the trees should have been planted with a view to such a method of cultivation. I also know of orchards grown on steep hillsides that are mulched each year after having the soil spaded up around them for a distance of several feet, with good results.

The Bag-Worm

N. K. H., Whitehall, Illinois—The sample of insect that you send on is what is known as the "bag-worm." The specimens received from you are bags about two inches long, which are in reality cocoons, and these are covered over with small, very light pieces of evergreen. On cutting them open, you will find a bunch of fuzzy material, imbedded in which is a mass of eggs. In the spring these eggs hatch, and the bugs make their way out through the mouth of the bag and feed upon the leaves. They soon begin constructing for themselves a case made of leaf fragments, which they carry on their backs. As the insects grow, they add to these bags, which soon become so heavy that they hang down. The insect continues to feed, attaching the bag by means of a silken thread to twigs when not moving about from place to place. Late in the summer they attach these bags permanently to the trees or other objects, and the caterpillars go through their changes. The sacks that inclose the males are smaller than those which inclose the females. As the latter grows, she develops a tremendous number of eggs, so that the whole sack is filled with them. These insects are very destructive. The best remedy is to gather and burn the sacks in winter. In summer the best treatment is to spray with arsenate of lead at the rate of three pounds to fifty gallons of water.

Trees About the Garden

O. P. I., Westbrook, Minnesota—You state you have planted a row of white spruce and ask what to use in the space between the evergreens and the highway, which is about twenty feet. I would suggest that the space is rather narrow for any of our larger-growing trees and that for the spruce to do their best they ought to have nearly all this space; but you might plant out to advantage a small tree like the European mountain ash, alternating with the evergreens, but not nearer than thirty feet apart. There would be no objection to putting out another row of white or Norway spruce, but the effect would be rather somber.

You state, also, that you intend to plant gooseberries, currants, etc., near this evergreen hedge, and ask if there would be any danger from the evergreens drifting the snow onto them. I do not think so, as your evergreens would be on the south of the garden, and the few heavy snows that we get from that direction seldom last long enough to form the crust which by its settling causes the damage we ordinarily attribute to snow.

McIntosh Reds for Minnesota

The McIntosh Red has done fairly well in a number of locations in Minnesota. Top-working it on the Hibernial I think would increase its hardiness. The Hibernial is one of the hardiest trees I know of for top-working, far better than the Virginia Crab which formerly I recommended, but found liable to body blight occasionally.

Buds or even trees of the McIntosh Reds that are grown in the Bitterroot

and Flathead Valleys can be safely imported into Minnesota and will make just as hardy trees as would buds from the same apple-trees growing in Minnesota or the Dakotas. The hardiness of varieties is not affected permanently by the section in which they are growing. I prefer, for top-working, trees planted out two or three years to those that are larger. I always prefer branches not over three fourths of an inch in diameter and, better, one half inch in diameter for top-working.

Grape-Vines Not Bearing

A reader at Sand Lake, Michigan, states that his grape-vines make a tremendous growth and that they are kept pruned, but that in spite of all that can be done, when the berries are about the size of BB shot or a little larger, they dry up and fall off. I think the trouble with your grapes is a disease of some kind which attacks them when small. You will find this a common trouble throughout the vineyard districts of your section. The best way of overcoming it is to begin spraying with Bordeaux mixture as soon as the flowers fall and repeat once in two weeks until they begin to color, which I think will be sufficient spraying to insure you a crop. You can obtain full directions as to how to proceed in making and using Bordeaux mixture by addressing the Michigan Experiment Station at East Lansing.

Catalpa Out of Place

J. D., North Dakota—Catalpa Speciosa, commonly known as hardy catalpa, is not sufficiently hardy for planting in any portion of North Dakota or Minnesota. While it may be grown in protected locations in Minnesota as a park or ornamental tree and occasionally attains a foot or more in diameter, yet it is not a safe tree for general planting, as it usually kills to the ground in severe winters. The best forest trees for planting in North Dakota are the white willow and cottonwood. The improved forms of the cottonwood, like the Carolina or the Norway, are better than those ordinarily found along the streams.

Saving Girdled Trees

It is a common trouble to have the bark of apple-trees eaten off by rabbits. If they are barked entirely around and gnawed down to the wood, there is very little chance of saving them, without putting on them more work than they are worth. If the trees are young and newly set, it is probably best to throw them away and start in new again. If, however, they are large trees, something might be done by bridging over the wounds. In this case, scions are cut from the tree in early spring and inserted under the bark above and below the injured portion. They soon unite and form a bridge for the sap. When treated in this way, the whole wound should be covered with grafting-wax or clay.

Yellow Locust in Minnesota

M. D., Clontarf, Minnesota—The yellow locust is generally hardy as far north as St. Paul. It makes a very rapid growth and is valuable for post timber, being very durable in contact with the soil. One of the worst troubles with it, however, is that it is liable to be infested with borers. The Forest Products Company of Red Wing, Minnesota, is planting large quantities of it on the bottom lands along the Mississippi River. They regard it as one of the most profitable trees for forest purposes.

When to Cut Willow

It makes little difference what time of year willows are cut, so far as their durability is concerned. If other work permitted, however, I would rather prefer to cut them the latter part of June. At this time the bark peels easily and should be taken off at once and the wood dries out readily. It is desirable to allow them to be thoroughly cured before placing in the soil.

Filling in Around Trees

B. A. Brown, Phenix, Rhode Island—In my experience, the filling in around vigorous-growing maple trees to the depth of about eighteen inches has not hurt them, though I should prefer not to have this filling of very compact soil. If the trees are weak, however, filling in to this depth might result in serious injury.

LET ME ADD A BRIGHT SPOT **TWO HUNDRED Gladiolus Bulblets**

and 5 blooming size bulbs for 25c.

These are the finest mixture of Field's Giant Flowering Gladiolus Mailed postpaid anywhere in the United States.

Or 1000 bulblets and 25 bulbs for \$1.00

Full cultural directions with every lot. All the bulbs and some of the bulblets will bloom this year, all next year. Order at once before they are gone. They will grow and bloom anywhere, in any soil and for any one.

My catalog (mailed free) describes over 50 beautiful named varieties besides hundreds of other kinds of flowers and vegetables. Ask for it.

Henry Field Seed Co.
Henry Field, Pres.
Box 80 Shenandoah, Iowa.

TO YOUR GARDEN

Gardening

By T. Greiner

Potato Scab Preventives

I AM asked about the formalin treatment of seed-potatoes. Most drug-stores keep formalin. It is inexpensive. The proper strength of the solution is one pint to thirty gallons of water. Immerse the potatoes, uncut, in this for one and one half to two hours. Don't be afraid to handle them. They will not poison you or cause sore hands. Dry them, cut them if desired and plant. Better not use any of the treated tubers as food for man or beast, however. This treatment will kill all the scab spores without in the least injuring the tubers, although, if the latter have already sprouted, it may burn the tips of the sprouts.

I always treat at least my early seed-potatoes for scab by what is known as the greening process. This is simply exposure to direct sunlight, the potatoes being spread out on a floor or the ground or in shallow boxes, such as are used in many places for marketing or transplanting early tomatoes. The potatoes are placed in single layer, or, if in double layer, are shifted around so that every part of every potato will be exposed for a while to full sunlight. This kills the spores of the scab, and the potatoes may then be safely planted in scab-free soil. This is a good method for the home grower. It does away with the need of handling the poisonous corrosive sublimate, or with the trouble of securing formalin, etc.

Potatoes freed from scab by any method, if planted in new soil or on newly-turned sod, will usually produce clean tubers. But if scab is present in the soil, there is no known method to insure healthy tubers in a season favorable to scab. The application of alkaline substances—lime, ashes, etc.—to the soil increases the scab. Soil that is a little sour invariably produces clean tubers.

Wood-Ashes on Garden Crops

"What garden crops respond best to applications of wood-ashes?" asks a reader. I believe there is hardly a garden vegetable that would not be benefited by them. Wood-ashes, of course, are especially strong in potash, and in order to make a better balanced ration, I use superphosphate (acid phosphate) with them. Bone-dust would also go well with them. But the ashes in themselves are valuable for crops requiring much potash, such as cabbages, cauliflower, celery, etc., and in combination with the superphosphate or bone, for peas, corn, tomatoes, melons, cucumbers, bush fruits, etc. In early spring I usually scatter what wood-ashes are available on any of my garden beds where onions and other small stuff and close-planted vegetables are to be planted. A little later I put the ashes along the celery rows, around egg-plants, tomatoes, peppers, lima beans, and so on.

There is a chance of ashes harming potatoes by increasing scab tendencies.

Snap Beans for Late Market

An Arkansas reader proposes to plant an acre of snap beans for late market. I do not believe in attempting to grow any untried crop on an acre scale, unless you can get the benefit of your neighbors' experience. In some markets a green snap bean is wanted, in another a wax bean. Sometimes we find demand for a broad pod and again for a round pod, depending on the whims of your market or particular customers. The grower must find these things out for himself. With us it is a comparatively easy job to grow snap beans of any kind. All we have to do is to plant them on good warm soil, such as will raise a good crop of corn, and keep them cultivated as one would cultivate corn or potatoes, and especially keep the plants picked clean right along. When you allow pods to remain on the bushes to ripen seed, the plants will soon give out. Snap beans are always a paying crop, when you have a steady demand for them.

Bean Rust

Anthracnose or pod rust of the bean has often ruined a large proportion of our string beans. The infection usually perhaps always, comes from the seed-beans. If we save our own, as we should, we can take proper care to select only sound, rust-free pods for next season's planting and we will have no trouble from rust. Better not plant any beans that you know were diseased when gathered last year. Throw them away and chance another lot from another source.

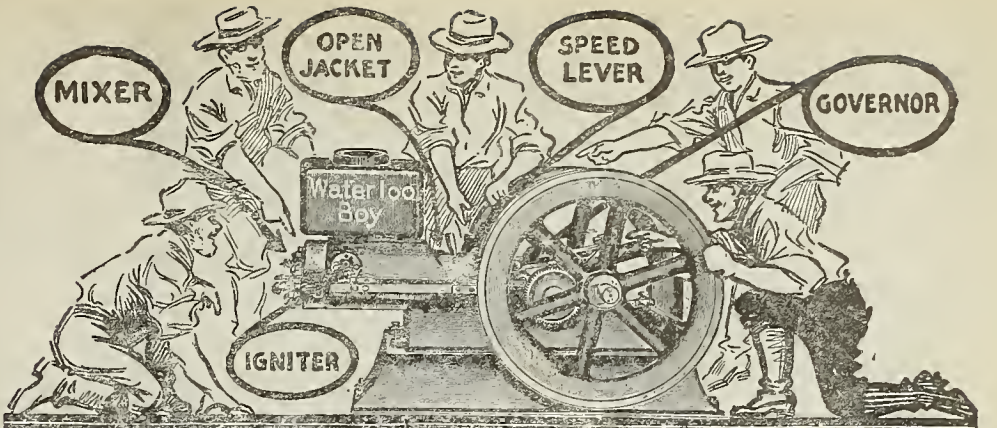

17 YEARS ON THE MARKET

The Waterloo Boy has all the Good Points that go into any Gasoline Engine

5 YEAR GUARANTEE

and it doesn't take the up-to-date farmer long to discover them and their value to him. It is the number of practical features embodied in an engine that determines the degree of satisfaction it will give to its owner. All gasoline engines have some good points, or there would be no sale for them and they would soon be taken off the market. Some engines have more good points than others, that's why some engines are better than others.

Waterloo Boy Gasoline Engines

have all the good points that go into any gasoline engine, besides many exclusive, patented features that increase their efficiency and durability; make them marvels of simplicity and wonderfully economical engines to operate. That's why we say the Waterloo Boy is the best engine for farm use.

You can buy a Waterloo Boy for less money than you will be asked for engines containing half of the good points we build into our engines. Besides we will send a Waterloo Boy to any responsible farmer and let him try it for thirty days on his farm doing whatever work he has to do. We will pay the freight both ways and return his money if after a month's use he cannot pick out the good points for himself—if he can't see that it is the one and only engine that will give him complete satisfaction.

Now, when you buy a gasoline engine you had better be sure that the engine you get was made by a concern that makes gasoline engines and nothing else. Our efforts are all directed toward making and keeping the Waterloo Boy the best engine in the world. We have no other interests—no side lines.

Don't you want to try a Waterloo Boy? Don't you want to see how much labor and time it will save you? Remember we are offering you a free trial for 30 days. Better write us today for our catalogue and free trial offer.

Waterloo Gasoline Engine Company
173 W. Third Avenue, Waterloo, Iowa.

30 DAYS FREE TRIAL

YEARLY CAPACITY 15000 ENGINES

Get all the Profit out of your grain with a New Huber Thresher

It bags all the grain you grow in clean, perfect condition—absolutely without waste and without crushing the grain. It saves the profits that the less thorough, ordinary thresher sends to the strawstack. It does the work quicker, yet requires less power to do it—that is where it saves you money. Every improvement which we have introduced has been thoroughly tested in actual use. The New Huber Thresher is staunchly built—will outlast any other make. You need a thresher, why not get the best—the one that will give you all the profit you should get from your grain? Write for our free illustrated book; it tells why you should have a New Huber Thresher on your farm. Write to-day.

THE HUBER MFG. CO., 606 CENTER ST., MARION, O.

35 YEARS GROWING EVERGREENS

and Forest trees. Over 35 tested hardy varieties. All Nursery grown. We have over 50 millions and ship safely to all parts of the country. Our trees live and grow, because they have good roots. Large as well as small trees supplied. \$4.00 and up per thousand.

Our new catalog is a mine of information. You can have a beautiful Windbreak, Hedge, Shelterbelt or Screen with the hardest of Evergreens at a very low cost. Our Bargain sheet describes 50 bargain lots from \$1.00 per 100 and up. Millions of Nursery grown Forest trees, Shade and Ornamentals, Shrubs, Roses and Vines. Send today for free Catalog and Bargain sheet.

D. HILL Evergreen Specialist
Box 233, Dundee, Illinois

POTATO DIGGER

The Hoover

Does perfect work. Fully guaranteed. Write for illustrated catalogue of Diggers, Pickers and Sorters.

THE HOOVER MFG. CO., Box No. 22, Avory, Ohio.

Transfer points—Buffalo, N. Y.; Detroit, Mich.; St. Paul, Minn.; Marshalltown, Ia.; Idaho Falls, Id.; Portland, Ore.; Spokane, Wash.; Winnipeg, Man.; Hamilton, Ont.; Fond du Lac, Wis.

GROW YOUR OWN FENCE POSTS

Strong, healthy seedlings of true Hardy Catalpa—Catalpa Speciosa 100 for \$1.00 Postpaid, or 300 for \$2.50 by Prepaid Express. Safe arrival guaranteed. Seed 25c per oz. or \$2.00 per lb. postpaid. Special Prices on large lots of seed or seedlings.

HENRY FIELD SEED CO., Dept. 80, Shenandoah, Iowa

Save Money on Berry Boxes and Baskets

Fruit and Vegetable Packages and Growers' Supplies of all kinds. Write for free money-saving catalogue and price list.

Largest Factory of its Kind in the Country.

NEW ALBANY BOX AND BASKET CO., Box 110, NEW ALBANY, IND.

PLANT VICKTOR POTATOES

You'll get a large crop of sound tubers free from the late blight rot. You can learn all about Vick Quality Seeds in Vick's Garden and Floral Guide for 1910—write for free copy.

JAMES VICK'S SONS, 415 Main St., Rochester, N. Y.

BEEKEEPING Its pleasures and profits, is the theme of that excellent and handsomely illustrated magazine, **GLEANINGS IN BEE CULTURE**. We send it for six months on trial for twenty-five cents, and also send free a 64-page book on bees and our bee supply catalog to all who name this paper.

THE A. I. ROOT CO., Box 7, Medina, Ohio.

ADMIRAL 2-MAN PRESS

3 FEED TO THE ROUND SELF FEEDER **CONDENSING PACKER**

ADMIRAL HAY PRESS CO. KANSAS CITY, MO.

LET ME START YOU IN BUSINESS!

I will furnish the advertising matter and the plans. I want one sincere, earnest man in every town and township. Farmers, Mechanics, Builders, Small Business men. Anyone anxious to improve his condition. Address **COMMERCIAL DEMOCRACY, Dept. 19, ELYRIA, OHIO.**

PATENTS SECURED OR FEE RETURNED.

Free report as to patentability. Illustrated Guide Book, and List of Inventions Wanted, sent free.

VICTOR J. EVANS & CO., WASHINGTON, D. C.

PATENTS WORTH FORTUNES

Inventors: Send 6 cts. for our Valuable Patent Books

E. S. & A. B. Lacey, Dept. 49, Washington, D. C. Est. 1869

This Hay Loader Will Outwear Several Others Because

It has no gears. It has no crank-shafts. It has no chains. It has no sprockets. It has no springs. It has none of the troublesome parts that are found on other hay loaders. It can be depended upon every hour during the haying season. What is more, it will do its work better with a lighter draft than any other loader and can be operated by one man. Its long, easy stroke makes it practically noiseless and prevents it from pounding itself to pieces, as other rake bar loaders do, with their short, pounding strokes. Drop us a postal and we will send you our Free Illustrated Circulars, which will interest every farmer. Write today.

LA CROSSE HAY TOOL CO. **Chicago Heights, Ill.**

It's Easy to Grow

100 BUSHEL CORN with Keller's Rotary Corn Planter Gauge

ALL your seed corn is bound to come up because every kernel gets planted the right depth. Our gauges fit any make of corn planter, and make the shoe cut just so deep, no matter what the speed or how uneven the ground. No clogging; no sticking; the wheels roll down the trash and make planting easy for you and your team. You harvest ALL the corn you plant, instead of only part of it, and get 100 bu. per acre where you've been getting 60 or 80. Our No. 1 Gauge has wheels 2 1/2 x 7 in., and single clamp. Price \$5 per set, complete with scrapers. No. 2 has wheels 3 1/2 x 10 in., and a powerful double grip clamp. Price \$6 per set, complete with scrapers. No. 3 is an improved Sled Gauge, made for those who still prefer this style. Long, wide blades, 3 1/2 x 20 inches. Price \$5 per set. All prices include free delivery to your nearest railroad station. Get our special money-making proposition, also our FREE BOOKLET. Don't risk forgetting it: write TO-DAY to

P. N. KELLER MFG. CO., Waterloo, Iowa

CYCLONE FENCES AND FARM GATES

INEXPENSIVE ARTISTIC DURABLE **CONVENIENT STRONG LIGHT**

There is no improvement you can make that will pay you better in satisfaction and in dollars than to surround your yard and garden with a neat and attractive **Cyclone Ornamental Fence**. They are made in many artistic patterns, of rust-resistant materials, and are so strong that they will require no repairs for years. Our special construction—called line wires and corrugated pickets—absolutely prevents the fabric from becoming unsightly on account of sagging or slipping of joints. **Cyclone Farm Gates** are made of the strongest material possible to secure for this purpose—special high carbon tubular steel. This makes a rigid durable gate that is light on hinges. The hinges, latches and all fittings are of malleable iron to insure against any need of repairs. By writing to-day for our catalogue you will obtain proof that it will pay you to buy **Cyclone Fences and Gates**.

CYCLONE FENCE COMPANY, Dept. 109, WAUKEGAN, ILLINOIS.

The Right Roof Saves Dollars

And dollars saved is money easily earned. The spring rains are coming and if your roofs need attention now is the time to get at them.

The roofing to use is

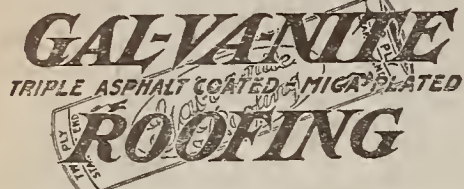

Because it is tough, pliable and easy to lay. Needs no painting or after attention; it is coated both sides with flaked mica, which protects the roofing from sparks and lightning, no rain or wind can blow it off, no heat no matter what the climate, can melt the asphalt waterproofing.

Valuable Book and Samples Free

The book gives valuable information about roofs and roofing problems; the samples will show the make up of Gal-va-nite, and to know its merits test the samples every way you can think of, then you'll decide in favor of Gal-va-nite.

Send for book and samples today.

UNION ROOFING & MFG. COMPANY

Main Office and Factories, 1141 to 1157 E. 7th Street ST. PAUL MINNESOTA

AUTOMOBILE BARGAINS!!!

AS THE LARGEST DEALERS IN THE WORLD in new and second hand cars, we have immense facilities to buy at great reductions and always have on hand a large stock of all the standard makes in the best condition at marvelously low prices. Send for our Bulletin, interesting to every owner or prospective owner of an automobile. Free on request.

TIMES SQUARE AUTO CO.

5 Big Houses ST. LOUIS Cor. Pine and 18th St. KANSAS CITY 1701-1703 Main Street CHICAGO 1332-1334 Michigan Ave. NEW YORK 215-217 W. 45th Street PHILADELPHIA 238-240 N. Broad Street

Send for Sample of PAGE WOVEN WIRE FENCE. We offer to send, free of charge, an actual sample of Page Woven Wire Fence, just as it comes from the big looms. Each one is a "sermon in steel." The tremendous success of Page Fence which is now on its Quarter Centennial Year, is due to the fact that its makers have always given full measure of honest value. It is the old reliable time-tried wire fence that outlasts them all. Admitted to be the strongest wire fence in existence. Send today! See the real Page Wire! Get next to the "Page Knot!" Get the great Quarter Centennial Edition of the Page Fence Catalog and learn the difference between Page Fence and the ordinary kinds. Find what Page Fence means in economy. Write at once and both the free sample of Page Fence and the big Catalog will be sent promptly. Address Page Woven Wire Fence Co. Box 239K Adrian, Mich.

Strongest FENCE Made. Made of High Carbon Double Strength Coiled Wire. Heavily Galvanized to prevent rust. Have no agents, sell at factory prices on 30 days' free trial. We pay all freight. 31 heights of farm and poultry fence. Catalog Free. COILED SPRING FENCE CO. Box 30 Winchester, Indiana.

Lightning Pitless Scales. New Pattern. Solid Channel Steel Frame. Channels are seven inches which is the height of platform from ground. Levers are octagon in shape giving greater strength. Bearing are Toolsteel. This Scale will last a life time with ordinary care. Equipped with compound Beam Free. Furnished absolutely complete except platform planks. Guaranteed accurate and tested to more than its capacity. Write for our prices and description before buying. KANSAS CITY HAY PRESS CO., 124 Mill St. Kansas City, Mo.

While West be Sure to Visit WALLA WALLA WASHINGTON. PRES. ROOSEVELT said: "Walla Walla made the pleasant impression on my mind of any city I visited in the Northwest." Come and Investigate. The Walla Walla Valley has a climate that is right, with Winters as mild as Kentucky and Summers as cool as St. Paul. Soil unsurpassed. Water plentiful. Results are certain. Values are still reasonable. HAS BEEN FAMOUS FOR ITS FRUIT FOR FIFTY YEARS - ALSO FOR ITS POULTRY. SPECIAL RATES on all railroads from March 1 to April 15. Buy ticket direct, or if bound for the Coast, get stopover at Pendleton, Oregon, (O. R. & N.), or at Pasco, Wash., (Nor. Pac.). Ask railroad agent or write to us. Commercial Club, Room 21, City Hall, Walla Walla, Washington. in the Southeast Corner of the Northwest State

Garden and Orchard

Dry Farm Gardening

MANY people here in western Kansas and Nebraska complain that they cannot raise as good gardens in the semi-arid belt as they can in other places. Now this may be partly true, but with a little more effort and judgment and attention good gardens can be raised here.

First select as good a piece of land as you have and as convenient to your well as possible for irrigation when necessary. Next select good seeds from as early-maturing varieties as you can procure, either for early or late planting. Then prepare the soil in as fine shape as you can, not too highly manured, but rich enough to insure rapid growth. If the ground is level, run the seed rows east and west, but if rolling, plant the rows according to the slope of the ground along the side hill so they will be nearly level.

Be careful not to plant too deep nor too shallow. As a general rule all flat seeds should be planted one half to one inch deep, and round seeds one to two inches deep. To make sure that the seeds will germinate properly, open the furrows and put in as much water as will make the soil very damp, then sow the seeds and cover with loose, partly dry soil to form a mulch. If the weather is favorable, the plants will be up in from a few days to two or three weeks, according to variety planted.

If it should rain before the plants appear, go over each row gently with a good rake to break the crust and also to form a mulch to hold the moisture. If it becomes necessary to irrigate, run your ditch on the north side of the rows that are planted east and west, as close to the row as possible, and let the water run along the ditch till the soil is well moistened. Then when the water is well settled in the soil, fill the ditch with dry, fine soil to prevent evaporation. When the ditch is put north of the row, the plants shade the ditch and it will remain moist much longer. Where the rows are on rolling land, put the ditch on the upper side of row, make the ditch considerably deeper and put in more water, as the sun will dry it faster. Keep the soil mulch loose, and if you keep the weeds out, you will get a good garden. Rotate the garden crops every year.

J. F. RAMBO.

The farmers of the more humid regions have much to learn of the "dry farmers." The above directions for raising gardens in the sub-humid regions may well be studied by all of us as hints for carrying our gardens through dry spells anywhere, east or west of the Missouri. EDITOR.

Look Out for Potato Canker

THIS disease has overrun Europe for the past thirteen years and has at last found lodgment in America. It was first discovered in Hungary in 1896, and was at first thought to be a disease common to the beet root in Africa, but on microscopic examination was found to be an entirely new disease. In 1898 its ravages became so alarming that legislation was passed to stay its spread. But with all these precautions it has become common in Europe and has ruined potato culture in some sections.

Since its advent in Newfoundland the Dominion has taken stringent measures to stamp out the evil there. But its proximity to our states make the strictest precautions necessary lest it get a foothold here.

The disease is known as black scab, canker potato or cauliflower scab. The most dangerous aspect of the disease is that its presence cannot be detected by the growth of the plant aboveground—that may be normal, while underground the crop may be entirely ruined. It resembles potato scab somewhat, but, unlike it, this disease entirely destroys the tubers. The disease begins at the eyes and spreads rapidly through every part of the tuber. It has the appearance of a warty growth of sprouts in and around the eye. This consists of a mass of microscopic excrescences much like the crown gall on the apple. It is not detachable from the tuber, but continues its growth until the tuber loses all resemblance to a potato.

The spores retain their vitality for several years, rendering successive crops on the same soil impossible. Singularly no other vegetable is affected by it.

Its introduction can be prevented by inspecting closely all seed imported for planting. If the potato is infected, the eye will be found of rusty brown and covered with a microscopic warty fungus. Such seed should be destroyed.

Circular 52, Bureau of Plant Industry, on this disease, says present laws give the secretary of agriculture no power to establish quarantines against plant diseases. There is something for farmer's organizations to agitate.

All importers of foreign potatoes, especially seedsmen, should take every precaution against the disease. Prevention before cure should be the rule in this case. J. H. HAYNES.

Manuring Potatoes After Planting

D. D. I. (no state named) asks: "Would it be any use to attempt to fertilize Irish potatoes after planting? If so, what kind of fertilizer is best and how should it be used?" It depends on soil and weather conditions. The outcome is at best problematical; the best "guesser" may give the best answer. I prefer to put in before planting whatever fertilizer I use and mix it well with the soil, especially underneath and surrounding the seed pieces. If that has been neglected, however, and the land is thought to be too poor to raise a good crop, a dressing of such fertilizer in a broad band over the rows, at the rate of four hundred or more pounds per acre, may be some help, but the sooner applied after planting, the better.

If soil is deficient in nitrogen, apply a light dressing of nitrate of soda (one hundred pounds per acre) the same way. In a dry season, however, little can be expected from any of these treatments. More effective, usually, is a heavy mulch of coarse manure or litter. T. GR.

Seeding a Lawn

AN ILLINOIS friend asks about seeding a lawn on which he has spread six to ten inches of black sandy soil, covering the old sod. I would suggest that you give it a coat of fine manure, unless the top soil is of best quality. I would then rake fine and sow it with a mixture of ten pounds of best Kentucky blue-grass seed, half a pound of redtop-seed and half a pound of white-clover seed. This should be thoroughly mixed together and sown broadcast over the lawn as early as possible, at the rate of about three fourths of a pound to each square rod of surface. If your seed is clean and good, you will succeed in getting a better lawn by so doing than you will by using sod, and the expense in one case will be a mere trifle of the cost in the other. In the case of old lawns that are thin, it is a good plan to put in an inch of black loam and reseed with the above mixture. SAMUEL B. GREEN.

Money in Early Tomatoes. One of my customers sold \$102.35 worth of big, red tomatoes from 100 plants in his back yard. Another from 14 plants in her flower garden, sold \$12 lbs. during July and August for \$16.70. It's all the knowing how and in using the right seed. They used my new tomato—Field's Early June. Earlier than Earliana, as handsome as Stone, as solid as Ponderosa, and a greater yielder than any of them. The greatest new tomato in 25 years. Small pkt., 20c; 3 for 50c; 4 oz., \$1. (This for specially selected seed, saved early.) My Garden Manual and Seed Catalog will give lots of pointers and good advice about gardening. It's well worth reading. Get it and see. Henry Field, Pres. HENRY FIELD SEED CO. Box 80, Shenandoah, Ia.

16% SEED BARGAIN. Here is a joy collection, beating the world, composed of 10,000 kernels. Richest, juiciest, tenderest seeds. 1500 Each, Lettuce, Turnip, Rutabaga. 1000 Each, Onion, Celery, Carrot. 1000 Each, Rarest Radishes, alone worth 16c! 100 Each, Parsley, Melon, Tomato. 1200 Brilliant Flower Seeds, 50 Sorts. In all 10,000 kernels, including big catalog, all postpaid, only 36c in stamps. Send us a name for our new breed of corn before May 10th, and if it is accepted, you will win \$500 IN GOLD. The new corn is not for sale, but it brings sample packet. You need not get sample to enter contest, however. Just give us the best name. If another sends in same (acceptable) name as you do, the prize will be equally divided. Mammoth catalog loaded with Seed News free. Address JOHN A. SALZER SEED CO., 119 So. 8th St., La Crosse, Wis.

SAVE MONEY ON ROOFING. \$1.00 buys full roll (108 sq. ft.) of strictly high grade roofing, either rubber or flint coat surface, with cement and nails complete. Most liberal offer ever made on first class roofing. Better than goods that sell at much higher prices. Don't spend a dollar on roofing until you have seen UNITO ASPHALT ROOFING. You send no money when you order Unito Roofing. Satisfaction Guaranteed. Write today for free samples for test and comparison and our unparalleled selling plan. UNITED FACTORIES CO., Dept. A49, Cleveland, O.

TREAT YOUR SICK ANIMALS. Wonderful home book by famous German Veterinary Surgeon. Describes diseases—symptoms of horses, cows, hogs, sheep, poultry, dogs. Makes all plain. Gives remedies in plain English. Saves money—doctor bills. Nothing like it. Free circular. D. MEINERT PUB. CO. Toledo, Ohio

CANADA LANDS. For many years past we have been the largest sellers of Canada Lands in the United States and refer to hundreds of satisfied buyers. Now we offer choicest selection in TRAPPING LAKE AND HOUGHTON LAKE DISTRICT. First Excursion in April, via our Private Car Lines. For low fares, meals and berths, address 221 Germania Life Bldg. ST. PAUL, MINN. LUSE-LAND AND DEVELOPMENT CO. FRESH-PAINT BOOK FREE. Don't buy a gallon of paint till you get my book on O. L. Chase Made-to-order Paint. I let you try 2 gals. out of any 6-gal. order or over, and pay the freight. That's my FREE TRIAL, FREIGHT-PREPAID OFFER. Return balance at my expense if not satisfactory and get ALL your money back. Write postal for book now. O. L. CHASE, THE PAINTMAN, Dept. 19, St. Louis, Mo.

WE SELL GUNS AND TRAPS AT LOW PRICES. WE BUY FURS AND HIDES PAY HIGH PRICES. Send for catalog No. 27. NORTHWESTERN HIDE AND FUR COMPANY, Minneapolis, Minn.

\$25.00 a day. New invention; horse owners wild about them; agents are coining money; sell on sight; write at once; free sample to workers. Automatic Co. G 1022, Cincinnati, O.

FARM WANTED. We want to hear from OWNER having good FARM for sale in good locality. State lowest price, as you will have no COMMISSION to pay. If you want to buy property of any kind it will be to your interest to write us. AMERICAN INVESTMENT ASSOCIATION, 815 Pulnce Bldg., Minneapolis, Minn.

PATENT YOUR IDEAS. They may bring you wealth. 61-page Patent Book Free. Fitzgerald & Co., Attys., Box N, Washington, D. C. Est. 1880

CLOVER and ALFALFA. Seed. Guaranteed pure—absolutely no weed seeds. Sold subject to State and National test. Write for free samples and special prices. HENRY FIELD SEED CO., Box 80, SHENANDOAH, IA.

MONTRUSS METAL SHINGLES. Last a lifetime. Nothing better sold. Used over 21 years. Fireproof, Ornamental, Inexpensive. Catalog Free. Montruss Co., Camden, N. J.

WHOLESALE PRICES. On Strawberry, Raspberry, Blackberry, Currant and Grape Plants. 18th annual descriptive and illustrated wholesale and retail catalogue FREE. Remember the name: IWAN. Made by Ivan Bros. A. R. WESTON & CO., B. D. 9, Bridgman, Mich.

IWAN POST HOLE and WELL AUGER. Buys itself in Two Days. Does a day's work in two hours. Fits a 3-foot hole in any kind of soil, wet or dry, in three minutes. Bites its way through solid clay, hard-pans, sand, gravel. If it isn't the best you ever saw, get your money back on request from dealer. With our simple, cheap pipe extensions it's easy to dig 40 to 60-foot wells. Thousands in use. Good dealers everywhere have it. Remember the name: IWAN. Made by Ivan Bros. See your dealer or write us today, mentioning his name, for free book "Easy Digging," full of tips on digging methods. Dept. H. (H) IWAN BROS., South Bend, Ind.

Garden and Orchard

How to Get Strawberries

MUCH is written every year on this subject, but as there is a constantly-increasing list of new growers who perhaps need some hints, a few such may not be amiss.

The work is simple, the main point being to keep it up the season through. No fruit responds more generously to care than does the strawberry. It has been our ideal fruit for fifty years, in which time we have tested about everything brought out and have grown thousands of our own seedlings.

A few things are indispensable for success in this work. Rich soil is necessary. We do not mean "naturally rich,"

berry-growers get their four ounce berries.

There are two classes of blooms in the strawberry—the perfect, or staminate, and the imperfect, or pistillate. The latter are the more robust plants, but must be fertilized by using staminates about every fourth row.

If you want to experiment with seedlings of your own, seed from the pistillate kinds are used.

The beginners should plant the standard varieties that are known to be hardy and productive. Experiment with new kinds lightly till better posted. The engraving is of a standard quart box of seedling berries—fifteen in the box—the largest was nearly ten inches in circum-

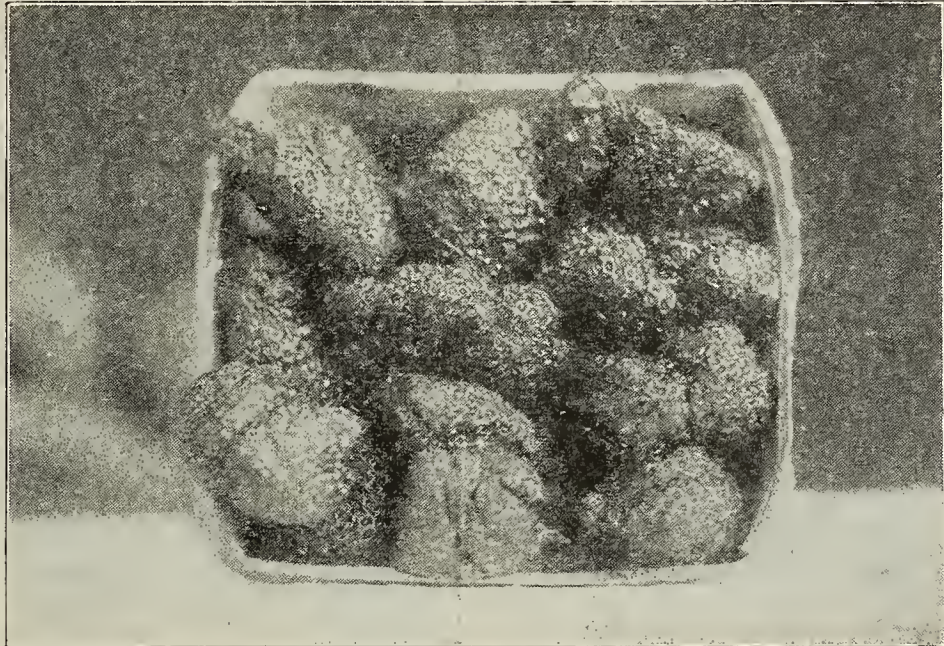

One Quart of Lusciousness

but rich in the elements to grow this fruit. Poor soils properly fertilized give more and better fruit than the rich black soils, which give too strong a plant to make good fruit. Even very sandy land if enriched makes the finest berries; the only hindrance being droughts after fruiting that kill out the beds. All soils should be well and deeply stirred so that the roots can go deep for moisture and nutrition.

Early planting is best if conditions are favorable, although we have planted any month in the year. If our own plants are used, we plant direct from the bed into the field. If purchased plants are used, a special bed is prepared in which they are set and cared for until they recover from the moving and form a mass of new fiber roots. When removed to the field they grow rapidly. Before removing them from this bed we soak it thoroughly; this makes the soil adhere to the roots. In setting, some get the plants too deep, others too shallow. The plant should be set with its crown just level with the surface.

There are three methods of culture, each having its good points according to what is wanted.

If we want lots of berries with little cost and work, we employ the matted-bed system—that is, we plant in rows five feet apart with plants two, three or four feet apart in the row, according to their habits of growth. Where the plant is a shy maker of runners, we plant two feet apart. The Bubach is this type. Such varieties as the Crescent and Dunlap can be set four feet apart and make a full bed in the season. No restrictions are put upon the new plants they produce.

If we want less, but larger, fruit, we use the hedge-row plan. Rows are three and one half feet apart and plants two feet apart, and then we allow each plant to give six or eight plants (no more) and these are stationed so as to form a bed about two feet wide. This system requires more work, but better and larger berries result.

If we want very large berries, we adopt the single-hill system. The rows are three and one half feet apart and plants one and one half feet apart and all runners are kept off. This gives us the finest of fruit but requires much labor. We have grown single-hill plants that a bushel would not cover without touching the foliage. If very large berries are wanted on these plants, the fruit is thinned, only the largest specimens shown in the first blooming being allowed to remain. The crown berry is the center berry in the clusters that bloom earliest. Here is where

ference, somewhat cock's-combe! in shape. These were grown in a matted-row bed.

The main point to remember is: Care for your strawberry-bed all through the season. J. H. HAYNES.

How I Set Out a Young Tree

I TAKE particular pains to select a place for the tree that is most suited in soil and location for its growth. I like a good dark sandy loam for apple and peach trees. I never set a tree in the shade of another or too near a building. These will be certain to prevent a healthy growth.

I dig a hole the right depth and diameter to admit the roots of the young tree so they may sprangle out sufficiently. A young tree never grows well when roots are doubled together or wound about one another. The soil in the bottom of the hole should be well pulverized before the tree is set into it. This gives the roots easy access to the soil. The tree is placed so that when the hole is filled the soil will come to the point on the tree reached by it in the nursery. I tramp the dirt about the roots as the hole is filled up, being careful that the tree is kept upright.



After the hole is about two thirds filled, I pour about the tree a couple of buckets of water. It will soak about the roots and settle the soil closely about them. The hole is then filled with dirt and some hay or trash thrown about the base of tree as a mulch. All broken and useless branches are cut away, and sometimes the limbs are trimmed back a good deal. I have seldom lost a tree set out by this plan. W. D. NEALE.

Agricultural News-Notes

It looks now as if the railway demonstration trains are likely to affect the attendance at the farmers' institutes.

In Belgium the four to five inch fresh shoots of the hop-vines are boiled and eaten like asparagus. Beginning with March they are found on the bills of fare of the large restaurants. The yield is seventy pounds to the acre. Why not test the quality of the hop shoots here?

At the great apple show held at Spokane, the first grand prize of one thousand dollars was awarded to the Spitzenbergers from Medford, Oregon, and the second prize to Grimes' Golden from Sunnyside, Washington. The largest apple exhibited was a Wolf River, which weighed twenty-five ounces and was sixteen and five eighths inches in circumference. *

**\$5000 A YEAR
AND MORE**

**FROM A TEN ACRE FARM
OUT IN THE UNION PACIFIC COUNTRY**

How do we figure it? Many ways—here's one: The superior quality of Oregon and Washington apples has set new prices for this fruit. They sell for about \$1.00 per bushel box, while special qualities from well advertised regions sell for \$2.00 or even \$2.50 per box. The trees run 100 to the acre and yield from 20 to 30 boxes per tree when in full bearing. Taking even 20 boxes per tree as the yield, and \$1.00 per box as the price, makes \$2,000. On a ten-acre farm, of which six acres was orchard, this would be \$12,000 or allowing for even the heaviest expenses, a net income of \$10,000.

But apples would be only one part of the income. Hogs fatten on the culls; strawberries, etc., grow at the rate of \$200 worth per acre between the rows of trees, and there are many other sources of incidental income.

One man sold out in Indiana, went to Eastern Washington and invested his capital of \$4,000 in 160 acres of land. Today he rents half of it for \$3,800 per year, and last year sold \$4,000 worth of apples from a small orchard that formed part of the other half. He also sold \$1,300 worth of blue-stem wheat.

See this country for yourself. Take

Union Pacific

"The Safe Road to Travel"

Electric Block Signals. Dining car meals and service "Best in the World."

Low Colonist fares will be in effect March 1 to April 15, inclusive, 1910.

For more complete information, or facts and figures about particular locations and what they mean to you, address

E. L. LOMAX, General Passenger Agent
Union Pacific R. R., Omaha, Neb. 43

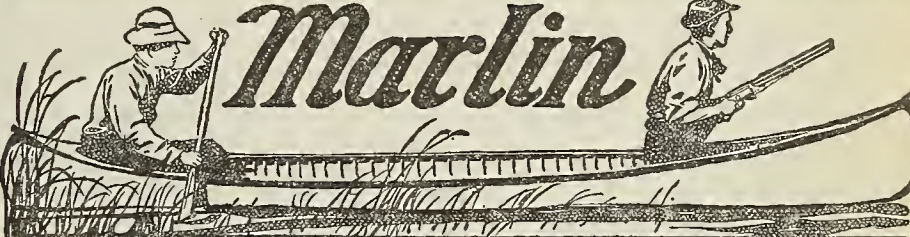

Marlin

WHETHER you live in the city or country, you'll find no .22 calibre repeating rifle like the *Marlin Model 1897*.

For the city man it is a perfect companion for the vacation or outing trip. It's light, takes down and packs in a small space. The ammunition is inexpensive. The gun can be used with .22 shorts for target and is equally capable of handling .22 long or long-rifle cartridges without change of mechanism.

On the farm the rifle is a necessity. The short cartridge is sufficient for sparrows, squirrels and small game; and the long-rifle cartridge makes the *Marlin Model '97* a distinctive weapon for geese, foxes, hawks, etc. up to 200 yards.

The "*Marlin Book*" of 136 pages, with handsome art cover, is jam full of up-to-date information for all gun-lovers and gives full description of all *Marlin* repeaters. It's FREE for 3 stamps postage.

141 Willow St., **The Marlin Firearms Co.**, New Haven, Conn.

GASOLINE PUMPING ENGINE

A Special Machine for a Special Purpose



A Lot of Power for a Little Money

This is the Engine for Pumping Large Quantities of Water for Watering Stock, Irrigating, Draining, Pumping out Mines, Quarries, Excavations or other places where a compact, powerful and low priced pumping outfit is wanted.

This Back-Geared Pumping Engine with Stuffing Box, as shown, ready to receive pipe connections, and capable of raising 260 barrels of water per hour to an elevation of 25 feet, 66 barrels to an elevation of 100 feet, or proportionate quantities to any height. F. O. B. Chicago

\$100

A complete pumping outfit assembled in one compact machine ready to receive the well connections and go to work just as soon as they can be attached. Cylinder, pipe and rod all fitted ready to screw together, for any lift from 25 feet to 100 feet, furnished for \$45.

This is an emergency outfit which can be shipped on an hour's notice and can be set up in complete working order within an hour after it is received.

This engine was specially designed for pumping. It can also be used for running a grinder, fodder cutter, saw or other light machinery; but, where operating machinery is the principal work, our \$75.00 2-H. P. general purpose engine with fluted cooler is cheaper and more suitable. Larger sizes at proportionately low prices.

If you need a small engine to operate "any old hand pump" our \$37.50 pumping engine is just the thing.

Remember that these engines are manufactured by the company which made the steel windmill business. Thousands of these engines are in use.

AERMOTOR CO., 2508 12th St. CHICAGO

Live Stock and Dairy

Grow Cows and Keep Them

I THINK I can see good money for the careful men who in the years coming will give intelligent attention to the breeding of good cows—not the general-purpose cow, but rather the pure dairy cow, the one that was not ordained for a single thing under the sun but to consume a lot of farm-grown feed and turn it into milk, year in and year out. This cow is the one that does not carry a lot of cheap cow beef in her frame, but lives for the single end of making milk.

Cows of this kind are in demand, and in dairy regions sell now for about twice as much as they did a few years ago. It is not a far cry to find the cause. Increased city consumption has stimulated dairy operations. Some men, when they want more milk, induce their cows to meet the demand by feeding them better and by putting more thought and work into their care. Other men simply go out and buy more cows, and there are enough of such men to keep the demand active and constant.

Then we have a class of dairymen who feed a cow all she will eat and have her ready for the butcher when she goes dry, and to the butcher she goes, and another fresh cow is bought to take her stall. This kind of moving-picture dairying uses up cows. The law of the survival of the fittest is not in force with dairymen of that class. But there is another law that is in force and has now come strictly into its own—the law of supply and demand. The fellows who buy, feed and slaughter cows are doing it faster than good cows can be produced. These rushers get on and off with a cow in seven or eight months. The average breeder takes two and one half years to produce a cow and two years more to bring her to maturity.

It is a fact that not one out of fifty of our dairymen is raising calves into cows to replenish the normal dairies, in which a cow is usually kept as long as her work justifies her being kept—and sad to record, often very much longer. Where a cow is needed, she is bought and she is always a cow that some one is anxious to sell. I am speaking from Pennsylvania experience, but to a greater or less extent the rule holds good everywhere.

I think I can see good money in breeding superior dairy cows for those good brothers who know they must have cows and think they cannot spare the time and effort to produce them themselves. A pure-bred, prepotent dairy bull used on average good cows will produce offspring that can be developed into the kind of cows that are demanded at good prices.

The obsolete idea that a cow can be milked for some years and then fattened into beef is largely responsible for the comparatively low market value some men put on cows. They weigh a cow on the beef scale instead of the butter-fat scale. The feed that will make two pounds of beef worth ten cents will make a pound of butter-fat worth thirty-three cents, so it is nothing but counting backward to talk about cow beef. A cow that will drop a good calf and during the year give seven thousand pounds of five-per-cent milk is a good one and has been well fed. A sensible dairyman should not think of selling such a cow for less than one hundred and fifty dollars to two hundred dollars, for the very good business reason that she will pay an excellent percentage on that investment in her.

That is the kind of cow it will always pay to produce, own and keep. When you have that kind, keep her price up. A good cow is like a good friend—always to be valued highly.

W. F. McSPARRAN.

Holding Hogs Humanely

ANY lice or mange on your brood sows? If there is, the best time to attend to it, of course, is before the pig crop arrives. Whenever you do it, let it be done on a reasonably warm day, and done with care and humanity.

Put the animals in a barn or shed out of the wind. Get a good stock-dip—write to your experiment station and find out what kind they use—and mix it according to directions in water that is about milk-warm. Then get a new, clean paint-brush—preferably a round one of good size—and try the following way of holding a hog:

Get a three-eighths-inch rope, eight or ten feet long, tie a small iron ring in one end, loop it just like the old-fashioned way, but, instead of putting it in the mouth and over the upper jaw, and having the hog pull back with all of its might and weight with the rope cutting its gums and mouth, put the rope

over both jaws, as far back as the mouth opening is, back the hog in a corner, tie or loop the rope to a post, slat or something that is behind the hog, and you can put on dip and kill lice with a great deal more ease to your mind and body, and comfort to the hog, than you can by having some one holding ears, legs and tail, or by the old scheme of the rope in the mouth.

I have dipped and handled dozens of pregnant sows this way, by myself, and they have never showed any bad results from it. When ringing, I use the rope in this way, and stand by the hog's side, and I can place the ring just where it should be. I have rung hogs by this system that ranged in weight from one hundred to six hundred pounds, without any help. It is the most humane way of holding a hog that I know of.

Never ring pregnant sows or dip them in a tank. Always see that they are well rung before they are bred; but if the rings work out and they root the sod up, it is better to put them in a lot or yard



"Back the hog into a corner"

rather than attempt to cut their nose or ring them, for such work is liable to cause abortion. Never ring any kind of hogs in a way that will interfere with their breathing. Ringing in the partition of the nose or in either side of the nose above each nostril is positively injurious and should never be practised.

ILLINOIS BOY.

Care and kindness in handling live stock have a balancing power not possessed by any other ration yet discovered.

The nature of some women is to cry over spilt milk. The nature of others is to call the cat and talk baby talk to her while she feasts on the milk.

EMPIRE Cream Separators

In Greatest Demand—Dairymen Investigate

40% more cow owners chose Empires last year than in any other year of their long, successful history. No other separator of any price or style even approached this great increase in demand. It proves that dairymen are realizing more and more how much quality counts and that they are investigating more carefully before they buy.

And Dairy Commissioners have been making the rules of cleanliness more strict. That's another reason why more cow owners are choosing Empires. They are kept perfectly sweet and clean without effort, no taint remains to spoil next skimming as is the case with ordinary separators, having nooks, corners, slots and crevices in the bowl parts.

Different Styles

The Empire Line includes not only various sizes and capacities, but different styles of construction, offering widest choice—every machine backed by the Empire Guaranty—as good as a Government Bond. Take your choice, the Frictionless Empire or the Empire Disc—each years ahead of all others in improvements. Let us prove to you that Empires turn easily, skim perfectly and give no bother for many years after ordinary separators have gone to the scrap pile.

FREE—Dairyman's Guide to Dollars. Let us send you our catalog of the complete Empire Line, setting forth the unbiased truth about different styles of separators. Address: EMPIRE CREAM SEPARATOR CO., Dept. A, 1225 Wabash Ave., Chicago Factory, Bloomfield, N. J.

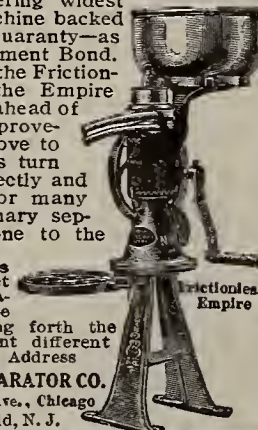

70c up to \$4.25 Buys the Most Useful Article Any Farmer Can Own

It is the great Burr Automatic Safety Tackle Block—the one rope tackle block that does a chain block's work. One man can do the work of four in changing wagon boxes, lifting injured animals, stretching wire fences, and many other farm jobs that need strength. It has no teeth, wedges and eccentrics to bite, tear and wear rope. It locks unfailingly and holds firmly and safely on greasy and wet rope, and in any position—even up side down. The simplest, strongest, handiest farm help ever invented. You couldn't afford to be without it if it cost twice the money. Capacity, 600 up to 5,000 lbs. Write today for catalog and complete instructions. BURR MFG. CO., 146 Viaduct, Cleveland



AGENTS are making big money in commissions and cash prizes taking orders for The Twentieth Century Peerless Atlas in combination with our periodicals. Some have devoted themselves to this work for ten, fifteen or twenty years, clearing from \$1,000 to \$3,000 annually. Returns proportionately good for those who give only part of their time. If interested, please write to

ATLAS DEPARTMENT

The Crowell Publishing Company, Springfield, Ohio

SAVE YOUR HARNESS

BY THE USE OF

HARNESS SOAP
HARNESS OIL
HARNESS DRESSING

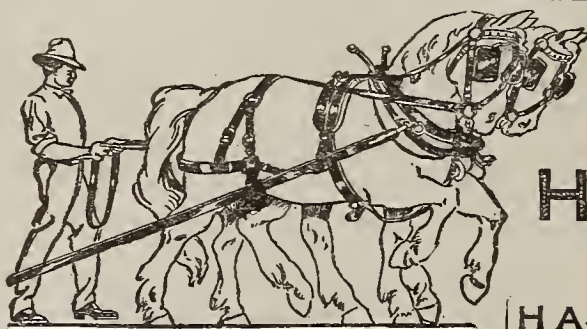

FRANK MILLER'S

Occasionally a dealer may try to substitute something on which his profit is larger, but the majority will recommend the old reliable Frank Miller's.

"BLACK BEAUTY" FREE

We want you to have a copy of this wonderfully interesting book, the "Uncle Tom's Cabin" of the horse. Probably no book has ever received such universal and unanimous praise from both the secular and religious press.

Write us to-day, mentioning this paper, and enclose 6 cents in postage, to cover mailing expense, and we'll promptly mail you a copy of "BLACK BEAUTY," 200 pages, colored covers, free of charge. Don't delay. Supply limited.

THE FRANK MILLER CO.

ESTABLISHED 1836
349-351 West 26th St., New York City



Let Us Divide the Middlemans Profit!

Cut out the middleman and buy from the factory. Try the MONARCH CREAM SEPARATOR at our expense for thirty days free. Then you will see that it is the closest skimming, easiest running and most compact separator on the market. The prices of Monarch Cream Separators range from \$29.75 up according to the capacity. Each Separator has an unlimited guarantee which will protect you for twenty years. Sell your poorest milk cow and buy a MONARCH, and the cream it will save will buy back the cow in just a few months' time. MONARCH CREAM SEPARATORS are sold on easy payments when desired. Our payments are arranged so that the cream you save pays for the separator. Write at once for catalog and particulars. LISLE MFG. CO., 971 Main St., Clarinda, Iowa.



Price \$29.75 and up



For 38 Springtimes thousands of the most successful stock and poultry men have tided their animals over the critical period between Winter and Spring by means of

Pratts Animal Regulator

for their live stock—and

Pratts Poultry Regulator

for their poultry.

For 38 Springs these unquestionably reliable preparations have given the Stock and Poultry of the country the elements they vitally needed—and couldn't get from ordinary food—the elements that made them healthy and strong and good producers.

There's a record unparalleled in the annals of stock and poultry regulators in the Continent of North America.

The above preparations are those you should use this Spring.

Remember they are absolutely guaranteed—and back of the guarantee is an honorable record of nearly half a century.

Pratts Powdered Lice Killer

Just the thing your hens need right now—prevents and kills lice.

At your dealers, or by mail for 25c.

The New Pratt Books

are ready! Have you sent for yours? If not, write to-day for the one that interests you most. Here they are.

Poultry Wrinkles. By Michael K. Boyer, Poultry Editor of the Farm Journal; author of "Poultry Secrets," etc., etc.

Things you ought to know by eminent vet-about horses and cows erinarians—both of them specialists on the care and health of live stock.

Write for whichever book interests you most. We want to send you a copy free.

Pratt Food Company

Department D Philadelphia

THE LARGEST AND BEST LINE OF

WELL DRILLING

MACHINERY in America. We have been making it for over 20 years. Do not buy until you see our new Illustrated Catalogue No. 15. Send for it now. It is FREE.

Austin Manufacturing Co., Chicago

OSGOOD "Challenge" Wagon Scale

Who weighs the products that you buy and sell? If you use somebody else's scales, you're going more or less "by guesswork." Install an Osgood Scale of your own and KNOW your weights—get full value for everything. Many styles to select from. Prices within your reach. Write for Catalogue OSGOOD SCALE CO., BOX 165 BINGHAMTON, N.Y.

WELL DRILLING Machines

Over 70 sizes and styles. For drilling either deep or shallow wells in any kind of soil or rock. Mounted on wheels or on sills. With engines or horse powers. Strong, simple and durable. Any mechanic can operate them easily. Send for catalog.

WILLIAMS BROS., Ithaca, N. Y.

Live Stock and Dairy

Would a Goat-Dairy Pay?

SEVERAL middle Western subscribers have asked that question. It would seem that in this country land is not yet high enough in price to warrant such intensive conditions as those which would be brought about by the use of goats as producers of dairy products. It is in countries where land is extremely high in price or mountainous, so that dairy cows would not do well, that the goat finds place, especially for producing milk for cheese.

The time is rapidly approaching in the middle Northern states between Iowa and Ohio inclusive, when farmers will realize the importance of more intensive farming and dairying. Farms will be made smaller and, although the likelihood is that they may be owned by large land-holders, still the tenant or farmer

cream and makes it so much the harder to get off. Her first operation was to thoroughly rinse the vessels with cold water. That freed most of the loose particles of matter that might remain in them. Then she took the hot water. Treated in that way not much soap was needed. But if she did use soap, she took care that it was the best.

This over, our friend, the good butter-maker, used a nice, clean, well-washed towel; not a rag, mind you, that would shed more lint and stuff than it took off, but a good firmly-woven cloth. This cloth was used faithfully, too. She was not afraid of rubbing off the tin. Tin is cheaper than carelessness, any day.

Now she used the cold water again, freely, thoroughly, with no cloth this time. Then, knowing the purifying power of fresh air and sunshine, she took her milk things out to a rack and



The Present Place for Goats in This Country is on Range Land Where They Are Raised for Fleece, Not Milk

will in the future be farming smaller areas. This is due to the fact that land in these states is becoming very high in price and at the same time much fertility is being lost, so that, acre for acre, much smaller crops are being raised now than a few years ago.

As a result of these conditions the farmer must keep more animals, thus retaining a large amount of fertility and marketing not grain, but animals and their products. The first improvement as pertaining to dairy farming must be a substitution of good cows for the poor ones. It has been truthfully estimated that about one third of the cows now upon our farms do not return very much profit to the owner and in many cases are an absolute loss. Dairymen are realizing this, and by the Babcock test and scales many of the more up-to-date and progressive are determining which cows are the losing kind, and disposing of them or bettering conditions of care, feed and environment, to give them a better chance to produce.

So long as there is so great a possibility to improve and make more profitable dairying by the substitution of good cows for poor ones, the likelihood is that the farmer in general will be more inclined to increase and make more intensive his dairy-farming operations in this way rather than by the substitution of goats for dairy cows.

HUGH G. VAN PELT.

Where She Hit It

IT WAS a source of wonderment to many of the neighbors of a farmer woman I know, why her butter always commanded a higher price than their own. They quizzed themselves about it first, for most of us are a bit proud when it comes to matters of this kind; but not getting much satisfaction that way they began to quiz her carefully, for they did not exactly like to own up their own lack of any of the details of butter-making. This is what they learned:

That woman knew how to wash the milk utensils with which she did her work. Does that seem to be a little thing? Little things mark the line between success and failure more times than we are apt to give them credit for.

The pails, cans, pans and other things were not permitted to stand around an hour or two after they were empty, before they were washed, so that the milk or cream or whatever it was did not get dried fast to the sides of these utensils. The first thing after they had been used, she made tracks for them.

Most of the neighboring butter-makers naturally gravitated into the kitchen and poured a lot of hot water into their pails the first pop. Not this woman. Why not? Because she had found out that hot water sets milk and

left them where they would be sterilized by Nature, the greatest agent any of us know.

And this was the great secret of that woman's success. Of course, she carried that system of neatness right on into all the details of her work. She never touched milk, cream or butter with her hands. The packages her butter went into were scrupulously neat. And she took the blue ribbons, while her neighbors were wondering how she did it.

E. L. VINCENT.

The Importance of Clipping Horses



before they are put at the hard spring work is now recognized as the proper thing by progressive farmers everywhere.

Horses are soft in the spring and sweat easily. Long hair holds this sweat and dirt, making it difficult for the skin to perform its functions properly. The wet coat is slow to dry, too, and leaves the horses liable to coughs, colds, pneumonia, and other ills. **Clipped horses dry out quick**, rest well, and get more good out of their food. A blanket, on cold nights, is much better than long, wet hair. Clipped horses look better, feel better, and do better work every time.

You can clip a horse in 30 minutes with the

Stewart Ball-Bearing Clipping Machine, only \$7.50

It is the finest clipping machine ever made. We have been making clipping machines for 20 years and it is our masterpiece. It's the only ball-bearing clipping machine. The gears are all cut from solid steel, are made file hard, and are shut in away from dust and dirt. They run in oil, too, doing away with almost all friction and wear. The knife is the famous Stewart single nut tension pattern, highest grade. **So good is this machine that we guarantee it to you for 25 years** No other machine ever made is so well worth the money.

You can get this machine from your dealer, or send \$2.00 and we will ship C.O.D. for balance. Get one NOW, Write for big, new catalogue.

CHICAGO FLEXIBLE SHAFT CO.
124 LA SALLE AVE., CHICAGO

Elkhart Buggies

are the best made, best grade and easiest riding buggies on earth for the money.

FOR THIRTY-SEVEN YEARS

we have been selling direct and are **The Largest Manufacturers in the World** selling to the consumer exclusively.

We ship for examination and approval, guaranteeing safe delivery, and also to save you money. If you are not satisfied as to style, quality and price you are nothing out.

May We Send You Our Large Catalogue?

Elkhart Carriage & Harness Mfg. Co.
Elkhart, Indiana

Save \$30



Freight Prepaid On "Breco" Rubber Roofing

DON'T spend a dollar for roofing until you have seen and tested our old reliable "BRECO"—guaranteed waterproof, fire-resisting, durable Rubber Roofing. Made by our own special process, of long-fibre wool felt, saturated in asphalt. **Free Cement and Special Roofing** Heavily coated on both sides.

Send for Free Samples and Booklet Get these samples of 1-ply, 2-ply and 3-ply roofing. Put them to every test you can think of and prove to your own satisfaction that "BRECO" Rubber Roofing is the highest quality roofing on the market. We give the

Longest Guarantee Send for samples or order now on our strong guarantee of satisfaction or money back. We pay freight to all points east of the western boundary line of Minnesota, Iowa, Missouri, and north of south line of Tennessee. Don't delay ordering; these special prices may not be offered to you again. Take advantage of them and write now, today—**THE BREESE BROS. CO., Roofing Dept. 24 Cincinnati, Ohio**

Lowest Factory Prices

Freight Prepaid on 100 lbs. or more

35-lb. Roll—108 **\$136**
Sq. Ft.—1-Ply
45-lb. Roll—108 **186**
Sq. Ft.—2-Ply
55-lb. Roll—108 **226**
Sq. Ft.—3-Ply

Order today, or write for Samples and Booklet

MOVING PICTURES

OF THE WONDERFUL WORLD CHAMPION

DAN PATCH 1:55

ABSOLUTELY FREE POSTAGE PAID

THIS IS THE LATEST HORSE SENSATION AND GREATEST TRIUMPH IN THE MARVELOUS AND REALISTIC MOVING PICTURE ART

It is a **New Invention** that you can carry in your pocket and show your friends instantly, day or night, either once or a hundred times and without a machine, curtain or light. It is the first successful moving picture ever taken of a World Champion horse in his wonderful burst of speed. A marvelous race sensation.

A MILE OF THRILLING RACE PICTURES 2400 MOVING RACE PICTURES OF DAN PATCH 1:55

and every picture shows the King of all Horse Creation as plainly as if you stood on the track and actually saw Dan Patch 1:55 in one of his thrilling speed exhibitions for a full mile. 2400 distinct moving pictures taken of Dan in one minute and fifty-five seconds means twenty-one pictures taken every second all of the way around the entire mile track from the back seat of a high power automobile. You can see Dan shake his head to let his driver know that he is ready for a supreme effort and then you can watch every movement of his legs as he flies through the air with his tremendous stride of 29 feet. You can see his thrilling finish as he strains every nerve to reach the wire, you can see his driver dismount and look at his watch while thousands of people crowd around, you can see his caretaker force his way through the crowd and throw a beautiful woolen blanket over Dan to prevent his catching cold and then you can follow him up the track before the madly cheering multitudes. As a study of horse motion it is better than the actual speed mile because you can see Dan right before you for every foot of the entire mile. When first shown to the public this marvelous picture caused people to stand up all over the theatre calling "Come on Dan!"—"Come on Dan!"

This remarkable moving picture is the most realistic and the most thrilling ever presented to the public. My Free Offer Subject To Withdrawal Without Further Notice.

I have taken a part of the original 2400 wonderful and sensational pictures and made them into a **Newly Invented Moving Picture** that you can carry in your pocket and show to your friends at any time, day or night. It does not need a machine, it does not need a curtain and it does not need a light. It is all ready to show instantly either once or a hundred times and Creates A Sensation Wherever Shown.

THIS MOVING PICTURE WILL BE MAILED TO YOU ABSOLUTELY FREE, WITH POSTAGE PREPAID, IF YOU ARE A FARMER, STOCK OR POULTRY RAISER AND CORRECTLY ANSWER THE THREE QUESTIONS.

If You Are A Farmer, Stockman Or Poultry Raiser I Require A Correct Answer To These Three Questions. → You Must Answer These Questions.

1st. In what paper did you see my Moving Picture Offer? 2nd. How many head Each of Horses, Cattle, Sheep, Hogs and Poultry do you own? 3rd. How many acres of land do you own or how many acres of land do you rent?

I Personally Guarantee To You One Of These Wonderful Moving Pictures Free If You Are A Stockowner And Answer These Questions And Write Me Today. Signed—M. W. SAVAGE.

IF YOU ARE NOT A STOCKHOLDER AND WANT THE MOVING PICTURES SEND ME 25 CENTS FOR POSTAGE

Packing, etc., In Silver or Stamps and I will mail you this Wonderful Moving Picture of Dan Patch 1:55, the fastest harness horse the world has ever seen.—If you send me Twenty-five Cents in Silver or Stamps—EVEN if you do not own any stock or land, I will mail it to you postage prepaid. Reproduction cost me thousands of dollars.

Address

Largest Stock Food Factory in the World
Capital Paid in \$5,000,000

INTERNATIONAL STOCK FOOD CO.,
M. W. SAVAGE, Proprietor
MINNEAPOLIS, MINN.

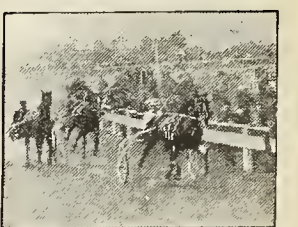
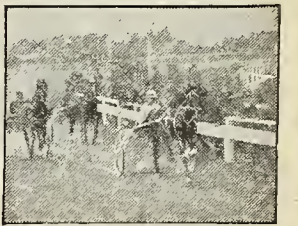

Live Stock and Dairy

These letters have vital interest to every dairyman East or West whose cows are consuming high-priced concentrates. This gospel of "grow your own protein" is of even greater importance to the man who has not been buying concentrates and whose cows have worried along on a ration lacking protein. EDITOR.

the Eastern man cannot compete and pay ten times as much freight. The answer for the Eastern dairyman, and for the dairyman anywhere who is buying his concentrates, is to learn how to grow the protein needed on the farm. When he has studied and mastered this question and grows clover, alfalfa, peas, beans and vetches, he will not only make more money, but will improve the fertility of his land. R. P. KESTER.

Don't Buy What You Can Grow

A GOOD increase in the milk and butter product of the average cow could be made by a more intelligent feeding of the animal, and often at no great increase of cost of feed. It is not economy in the first place to feed a good cow sparingly. Her profitableness depends on the amount over and above what she needs for the up-keep of her own body. Up to a certain point the bigger the surplus, the bigger the milk-flow. Anything short of this maximum amount lessens her possible yield. The first thing to find is the largest amount of feed she can profitably use.

It is well to remember that a cow must be full, in order to do her best; hence she needs a considerable amount of bulky feed. And this bulky material is best furnished by generous feeds of hay. Many farmers think because they are feeding grain heavily this filling may be of straw or corn-stover, too often of poor quality. This is not profitable for some of the energy gained from the grain ration is used in digesting and taking care of the excess of fiber found in straw.

Neither does ensilage alone make the right sort of bulky material. Good hay should be supplied in addition, and if this is not to be had she must be given something else, even if it is straw.

On the feeding scheme of the average farm, too much is expected of the carbohydrates and roughage. Many cows are limited to hay, corn-stover, straw and corn-chop, because these are handiest. To produce any given article we must have the required raw material, and the feeds named do not contain the raw material out of which milk is manufactured. Protein is deficient and milk-making takes protein. To balance up the ration from the articles named we may add materials like wheat-bran, middlings, gluten, linseed, cotton-seed, buckwheat-middlings, etc.

The increasingly high price of these by-product feeds is a matter of serious concern, to the Eastern dairyman especially. The states that were formerly the source of supply have gone extensively into dairying and are using these feeds at home and shipping dairy products to Eastern markets. Since one car-load of dairy products represents approximately ten car-loads of feed, it is obvious that

THE other day I heard a man hurl this question at another man who had asserted that the dairyman was making good money at present prices for dairy products:

"How can a dairyman make money when he is paying thirty-four dollars a ton for gluten feed, thirty-seven dollars for cotton-seed meal and thirty-eight for linseed-oil meal, and selling his milk at thirty-six dollars a ton?"

Let us reason together. Suppose the cow is eating thirty pounds of silage, worth three and a half cents; twelve pounds of hay, worth nine cents, and eight pounds of fine feeds, worth fourteen cents. This totals twenty-six and a half cents. This cow getting such a full feed, if she is any good, must give twenty-five to thirty pounds of rich milk a day. Thirty-six dollars per ton means one dollar and eighty cents per one hundred pounds for milk, and twenty-eight pounds of milk will bring fifty cents, or, to be exact, a profit of twenty-three and nine tenths cents per day.

This is not a bad showing on its face, but that profit is not net profit. There are fixed charges for labor, for interest on the investment in cow, barn and dairy fixtures, a charge for depreciation of the cow. There is always the possibility that the cow that does well this year may slump next year; consequently, in dairy figuring, it is always necessary to allow a margin for the unexpected.

It will be observed that in this estimate of cost the largest item was for concentrated feeds—fourteen cents. This is all out-paid money, but with a credit item in its favor for the increased value of manure, by reason of the nitrogenous character of the feed. The other items in the ration cost, being for home-grown feeds, represent a profit for the farmer which he charges to himself as a dairyman.

Corn-silage was priced in the ration at three dollars a ton, but considering its real feeding value in relation to present cost of other feeds, it is my opinion that good corn-silage is worth nearer three dollars and a half a ton. If the yield is fifteen tons per acre, the acre value would amount to fifty-two dollars and fifty cents. If you dispose of it in your own dairy barn, you are getting a good profit out of feeding it, supposing it is worth that price.

This crop teaches the farmer-dairyman a lesson in farm economics. If he can raise this one crop so profitably, why cannot he grow almost the whole ration? If it pays to go to the mills and buy that fine feed at the rate of fourteen cents a day per cow, may it not pay him well to raise on his farm such feeds as will, if not entirely, take the place of what he is buying, at least considerably reduce it? As crops he may consider the production of, I strongly recommend alfalfa, soy beans or cow-peas, according to the region. I am taking it for granted that he is raising corn to the extent of his capacity.

A good dairy cow will do pretty strong work on a ration of corn-silage and alfalfa-hay. Of course, she will do better if she gets a meal mixture in addition, but at the present high prices of the fine feeds it becomes a problem for the dairyman to figure out how much of them, if any, it will pay to use. He will probably settle on four or five pounds a day.

I believe if he will grow sweet clover and cut it into his silo with his corn, say one part clover to three of corn, and will grind into a fairly fine meal part of his alfalfa-hay, and make a daily ration from the following formula, he need buy no commercial feeds to make his good cows very productive ones: Corn and clover silage, thirty pounds; alfalfa-meal, seven pounds; corn-and-cob meal, four pounds; alfalfa-hay (or good mixed hay), twelve pounds.

The use of the ground corn suggests, of course, that all the corn crop does not go into the silo; and when corn is husked we have stover, which, when cut early and stored carefully, is a pretty good cow forage and an excellent one for horses and hogs. It can be added to the above ration as a gratuity for the cows in their well-doing.

W. F. McSPARRAN.

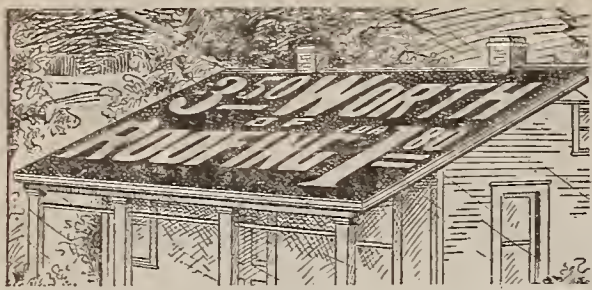

READ THESE ROOFING BARGAINS

and Remember That We Sell Only the Most Dependable Grades of ROOFING

Dealers' Prices		Our Prices
\$1.00	Rolls of Two-Ply Tarred Felt Roofing, containing 108 square feet	\$0.54
1.50	Rolls of Asphalt Felt Composition Sanded or Rubber Roofing - -	.89
2.00	Rolls of the highest grade of wool felt asphalt Best-ov-al Rubber Roofing	1.25
2.75	Rolls of the highest grade of wool felt asphalt Best-ov-al Rubber Roofing	1.50
3.50	Rolls of the highest grade of wool felt asphalt Best-ov-al Rubber Roofing	1.80

Send for These Free Samples and This Free Roofing Catalog

It quotes the very lowest prices on every kind of roofing, showing also a full line of steel roofing, painted or galvanized finish, at prices 25 per cent below market quotations. Every roofing sample is marked with the number and price, making it easy for you to compare values with what you can obtain locally. Our Roofing Catalog tells exactly why we give you better roofing for your money than you can obtain elsewhere.

Write your name and address plainly in the coupon below and as soon as we receive it we will send you by return mail our free Roofing Catalog and our complete line of roofing samples.



Sears, Roebuck and Co.
Chicago, Ill.

Roofing— Farm and Fireside

Name _____

Postoffice _____

R. F. D. No. _____

State _____

P. O. Box No. _____

Street and No. _____

CUT OUT COUPON AND MAIL TO US.

Sears, Roebuck and Co., Chicago

\$15⁹⁵
AND UPWARD

THE LOW DOWN AMERICAN SEPARATOR

EXCELS ANY SEPARATOR IN THE WORLD

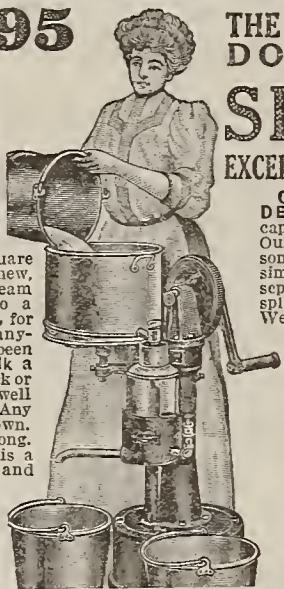

THIS OFFER IS NO CATCH. It is a solid, fair and square proposition to furnish a brand new, well made and well finished cream separator complete, subject to a long trial and fully guaranteed, for \$15.95. It is different from anything that has ever before been offered. Skims 1 quart of milk a minute, hot or cold, makes thick or thin cream and does it just as well as any higher priced machine. Any boy or girl can run it sitting down. The crank is only 5 inches long. Just think of that! The bowl is a sanitary marvel; easily cleaned and embodies all our latest improvements. Gears run in anti-friction bearings and thoroughly protected. Before you decide on a cream separator of any capacity whatever, obtain our \$15.95 proposition.

OUR LIBERAL TRIAL ENABLES YOU TO DEMONSTRATE THIS. While our prices for all capacities are astonishingly low, the quality is high. Our machines are up to date, well built and hand-somely finished. Run easier, skim closer, have a simpler bowl with fewer parts than any other cream separator. Thousands of machines in use giving splendid satisfaction. Write for our 1910 catalog. We will send it free, postpaid. It is richly illustrated, shows the machine in detail and tells all about the American Separator. Our surprisingly liberal long time trial proposition, generous terms of purchase and the low prices quoted will astonish you. We are the oldest exclusive manufacturers of hand separators in America and the first to sell direct to the user. We cannot afford to sell an article that is not absolutely first class. You save agent's, dealer's and even catalog house's profits by dealing with us and at the same time obtain the finest and highest quality machine on the market. Our own (manufacturer's) guarantee protects you on every American Separator. We ship immediately. Western orders filled from Western points. Write us and get our great offer and handsome free catalog. ADDRESS,

AMERICAN SEPARATOR CO., BOX 1058, BAINBRIDGE, N. Y.

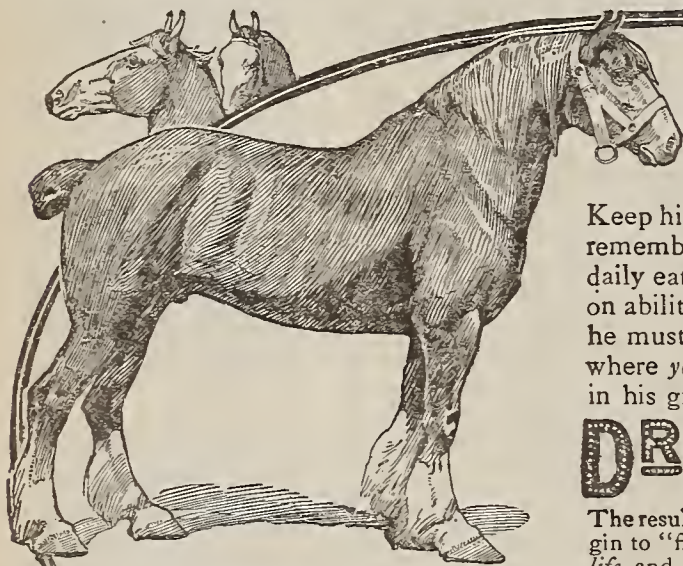

Don't Let Your Horse Lose Spirit

Keep him vigorous, full of power and ambition. Your horse, remember, takes a small ration compared with the great bulk daily eaten by a steer or cow. His "fitness" therefore, depends on ability to get *all the nutrition* out of this smaller feed. Plainly, he must have a *strong and regular power of digestion*. Here is where you can help your horse. Give him, morning and night, in his grain, a small dose of

DR HESS STOCK FOOD

The result will be almost instantly noticeable. If thin, your horse will begin to "fill out"; his dull coat will show gloss; his eyes will sparkle with life, and your dispirited, dragged-out "hack", appear with the "get up" of a prize winner. All because Dr. Hess Stock Food acts upon

his digestive organs, gives them strength and tone, and relieves minor ailments. Improving condition, increasing growth and milk production by improving digestion, is "The Dr. Hess Idea." The dose is small and is fed but twice a day. Sold on a written guarantee.

100 lbs. \$5.00;
25 lb. pail \$1.60.

Except in Canada and extreme West and South. DR. HESS & CLARK,
Smaller quantities at a slight advance. Ashland, Ohio.

Also Manufacturers of Dr. Hess Poultry Pan-a-ce-a and Instant Louse Killer.

Free from the 1st to the 10th of each month—Dr. Hess (M. D. D. V. S.) will prescribe for your ailing animals. You can have his 96-page Veterinarian Book free any time for the asking. Mention this paper and inclose 2c. stamp.

DR. HESS POULTRY PAN-A-CE-A

Give a little of Dr. Hess Poultry Pan-a-ce-a to your laying hens every morning; and don't forget the growing chicks, or the old fowls you're fattening to sell. Pan-a-ce-a is a wonderful help—in fact, it's the *necessary basis* on which to build a *successful* poultry business. It increases the hen's power of digestion so that a *large* percentage of her food goes into eggs and flesh—that means *economy and profit*. In the same way (by aiding digestion) it helps the little chick and the old fowl. It also cures Gapes, Cholera, Roup, etc. A penny's worth feeds 30 fowls one day. Sold on a written guarantee.

1 1/2 lbs. 25c, mail or express 40c; 5 lbs. 60c; 12 lbs. \$1.25; 25 lb. pail \$2.50.
(Except in Canada and extreme West and South.)
Send 2 cents for Dr. Hess 48-page Poultry Book free.

INSTANT LOUSE KILLER KILLS LICE

Live Stock and Dairy

\$27⁹⁰ to \$42⁵⁰

The Lowest Prices Ever Quoted for Practical Dairy Separators.

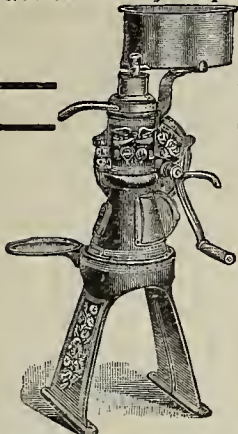

We do not advertise or sell small capacity kitchen separators made to set on a table. Some dealers are representing such toys as practical dairy machines. Our Economy Chief Separators are all big, strong, solid, substantial machines, built for the business of dairying, guaranteed to do the work and produce the profits. Every one is mounted on its own solid base and is of the finest and most substantial construction. Even the smallest Economy Chief, at \$27.90 complete, has a skimming capacity of 300 pounds, or 145 quarts per hour. It will skim any quantity from 1 gallon up. Sixty days' trial to every buyer. Fill out this coupon for our free Dairy Guide, the book that tells you all about the Economy Chief Separator.

Sears, Roebuck and Co., Chicago, Ill.
Please send me your free Dairy Guide.

Name _____
Postoffice _____
R. F. D. No. _____ State _____
P. O. Box No. _____ Street and No. _____
Farm and Fireside _____

SEARS, ROEBUCK AND CO., CHICAGO

Spare the Runt—Sometimes

THE runt that was shown in the picture on Page 22 of February 10th FARM AND FIRESIDE might well have been killed on first sight, as the writer said, as there were quite enough pigs left on the sow after the six were overlaid, without the runt. But suppose that there was a scarcity of pigs on the farm. The runt will not always stay a runt if given an opportunity to develop. Once I remember giving the runt of a litter of eight a chance to develop. It was eight weeks old the day it was separated from its mates, and weighed exactly twenty pounds, while its mates averaged thirty pounds each. This was June 1st. The pig was put on a ration of wheat-middlings and buttermilk at first, then when corn began to get hard it was fed a light ration of that. On the twenty-first of November the pig dressed one hundred and ninety-seven pounds. The heaviest feeding that it ever got was eight ears of corn at a feed twice a day, and this only for two or three weeks before it was slaughtered. Another time a runt, separated from the others at nine weeks old, was fed



This Fellow Was a Runt Once

in the next three months a total of three hundred and eighty-four pounds of corn, oats and buckwheat, ground, mixed with wheat-bran and water to make a slop. It dressed at one hundred and three pounds at five months. Another idea is suggested by that article. It was stated that the sow had farrowed seventeen pigs in that one litter and overlaid six of them before they were two days old. Would it not have been better if there had been only ten of them and none killed? It seems to be the popular idea to breed for large litters, but eight or ten pigs are as many as one sow can take care of. I owned a sow that never farrowed more than ten at a litter and another that averaged twelve or thirteen, but the average of pigs raised was as good for the first sow as the second. Is it not better to select for our breeding sows the kind that give only medium litters? This would not tax the mother's system so heavily and would reduce the number of runts farrowed. A. J. LEGG.

THE advice to kill all runts as soon as found seems to me to be rather too sweeping. Circumstances alter cases. If the runt is to be left to take its chances with a litter of stronger pigs, it had better be killed at once as an act of mercy, for it will be pretty sure to die after a lingering struggle against heavy odds. But if conditions will permit the runt to be taken away from the sow and given a little special care, it will very often pay as well as any hog on the farm. Three years ago one of our sows came in from the woods with four pigs about eight or ten days old. We put her in a yard with good shelter and began feeding her. One noon when she had been shut up a week she would not come out of her bed. We did not disturb her, thinking perhaps we had fed her a little too heavily. At night she came for her feed as well as ever, but in the bed were eight pigs instead of four. She had had two litters of four each two weeks or more apart. One of the last litter was the runtiest kind of a runt—the tiniest specimen of a hog that I ever looked at. Of course, he had no show against seven other pigs all stronger than himself, so my sister took him and raised him as a pet. He flourished from the very start. Through the summer he had the run of the orchard, and when he was killed at ten months old he weighed three hundred pounds. No hog we had that year gave a larger profit than this runt. The accompanying picture shows him at about nine months of age. There is much said in some quarters about the "Razor-Back" of the Ozarks. Well, the picture shows a typical one.

This is the common stock that runs over the hills and valleys of these Ozark Mountains. COURT W. RANSLOW.

We fear that the Ozark standard of nose and bristle for the razor-back is miserably low! Down in the piney woods of Alabama it is said that the pure-bred razor-back may be detected by measuring the distances from the top of the head to the tip of the nose and the tail respectively. If the distances are the same, the animal is eligible to registration. Mr. Ranslow's hog could never break into such select circles of elm-peelers. EDITOR.

Skin Comfort for Sheep

A READER at Morenci, Michigan, has several sheep that were troubled with ticks. He used one of the regular commercial dips, parting the wool every two inches and pouring on the dip. It abolished the ticks, but he is doubtful about trying it on all the flock for fear of damaging the wool. The dip used will not degrade the quality of the wool at all. Many flockmasters are practising this method of treatment, if they have only a few members in the flock affected with ticks, but when there is a large flock, this becomes a long and tiresome piece of work. A better plan is to wait a little while longer until the weather gets warmer and more settled, and shear your sheep first and then dip them in any of the recommended coal-tar dips, which make a clean job of the whole affair. It is customary among sheepmen to dip their sheep twice a year, in spring after shearing and in fall before the weather gets cold, so that they will go clean into winter quarters and will not be annoyed by this pest, which makes them restless day and night. A big waste of feed is the result, as a good deal of the feed taken by the sheep is used up keeping all those ticks alive, until it seems like putting grain into a bag with no bottom to it. Dipping does not harm sheep; in fact, it is good for their skin and promotes the growth of their wool. FRANK KLEINHEINZ.

Anti-Sucking Schemes

AN INQUIRY about the cure of a cow that sucks herself comes from Phoenix, Arizona. Most hardware and implement stores handle a patent anti-sucking device that can be hung on the cow's nose in such a way that sucking becomes impossible. If it is impossible to obtain one of these, the halter can be arranged in such a way as to break her of the habit. Take six-penny nails, file the points down sharp and drive them through the nose-band of the halter quite close together. Between the nail-heads rivet a strap tightly to the inside of the nose-band in such a way that the nails are held firmly, the sharp points outward. Put the halter on the cow and she will soon be glad to relinquish the self-sucking habit. H. G. V. P.

Are They Afraid?

Twice this year we have publicly and widely made the following fair offer to manufacturers of common cream separators. We again repeat it:

If any maker of common cream separators will print the names and addresses of all persons who—for any reason whatever—exchanged Tubulars for his machine during 1909, we guarantee to print a list AT LEAST TEN TIMES AS LONG of those who discarded his class of machines for Tubulars during 1909.

No manufacturer has accepted this offer. Are they afraid? Is not their silence the best proof that Sharples Tubular Cream Separator sales exceed most, if not all, others combined—that Tubulars probably replace more common separators than any one maker of such machines sells? Could you ask any better reason for choosing the simple, sanitary, easy-to-clean Sharples Dairy Tubular—The World's Best? World's biggest separator factory. America's oldest separator concern. Branch factories in Canada and Germany.

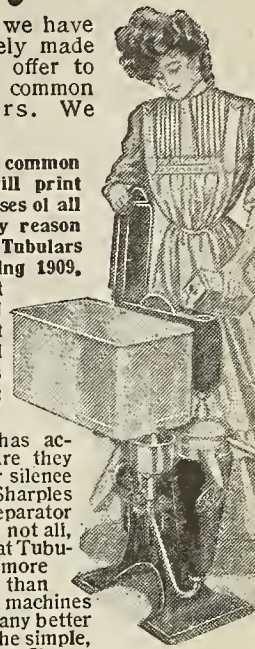

To oil the Dairy Tubular, pour a spoonful of oil into the gear case once or twice a week. Self oiling. No oil cups, tubes or holes.

Write for New Catalog No. 112.



THE SHARPLES SEPARATOR CO., WEST CHESTER, PA.
Chicago, Ill. San Francisco, Cal. Portland, Ore. Toronto, Can. Winnipeg, Can.

BEES PAY BIG

and require little care. All the little honey-gatherers and money-makers demand of you is to provide a home for them. They make the honey and you get the profit. What little work you must do can be made 100 per cent. easier and your profits 100 per cent. bigger if you have the RIGHT KIND OF SUPPLIES. If you are a bee-keeper or are thinking of going into the bee business you ought to have our beautiful illustrated New Bee Book—just off the press. It's a complete guide to profitable bee culture. Tells you how to buy bees, what kind are best, where to locate the hives, how to care for them summer and winter, how to prepare the honey for market—in fact it tells you all you need to know to make bees highly profitable as a business or a side-line.

SEND FOR THIS FREE BOOK. We sell everything the bee-keeper needs and can save you money whether you keep few bees or many. Buy direct from headquarters at rock-bottom prices. Get our bee book and save money. Write now for a copy as the edition is limited. BLANKE & HAUK SUPPLY COMPANY, 222 Blanke Building ST. LOUIS MO.

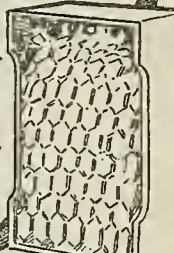

EXCELL STEEL ROOFING and IRON & SIDING

Direct To You from our own factory at lowest factory prices. We are manufacturers and handle no 2nd hand nor short length stuff. Every part of our roofing and siding is made in our factory from genuine Charcoal Iron, Double Refined Puddled Iron or Steel. Put on the kind of roof that wears. Ours is guaranteed. If it isn't the best you can buy anywhere, don't pay for it. Easy to lay. No experience needed. Tell us about your building and let us quote you factory prices. Write for Metal Goods Catalog. It is free. THE UNITED FACTORIES CO., Dept. No. R49, Cleveland, Ohio

ABSORBINE

Cures Strained Puffy Ankles, Lymphangitis, Poll Evil, Fistula, Sores, Wire Cuts, Bruises and Swellings, Lameness, and Allays Pain Quickly without Blistering, removing the hair, or laying the horse up. Pleasant to use. \$2.00 per bottle at dealers or delivered. Horse Book 5 D free. ABSORBINE, JR., (mankind, \$1.00 bottle.) For Strains, Gout, Varicose Veins, Varicocle, Hydrocele, Prostatitis, kills pain. W. F. YOUNG, P. D. F., 284 Temple St., Springfield, Mass.

ELECTRIC Handy Wagons, Steel Wheels.

Save your strength a thousand times with the low lift. Easier on the horses; easier on you. Wagon for all work. No shrinking, no breakdowns or repairs. All widths of tire. 20 to 60 inch wheels. Send for free catalog of up-to-date farm wagons to ELECTRIC WHEEL COMPANY, Box 13, Quincy, Ill.

Fernald Dash Rein Holder

protects you against runaways when horse is left unwatched. Keeps the reins from under horse's feet. Switching tail cannot jerk reins loose. Fits tight on any dash. Lasts as long as the buggy. No bolts or screws required. Simply slips on dash and stays in place. Is ornamental too. Nickel or baked japan finish. Too low priced for you to be without it. Ask your hardware or harness dealer or write us. Fernald Mfg. Co., North East, Pa.

Steel Wheels

will make your old farm wagon as good as new. Save money because they never need repairs. Write for our big free book telling all about them and how they pay. Empire Mfg. Co., Box 763, Quincy, Ill.

"Cow Troubles"

Is the title of our Book 6-A that is sent free, telling how to relieve Caked Bag, Sore or Injured Teats, Spider in Teat, Cow Fox, Udder Troubles, and prevent Heifers from becoming hard milkers with

"Cows Relief"

\$1.00 per Box Delivered, or at Dealers' O. H. MFG. CO., 38 Chapel St., Lyndon, Vt.

SEND US \$1.00

for this IMPROVED IMPERIAL BIT and control any vicious horse. Easy, humane, powerful. Insures safe driving of any horse by women or children. The best bit for tender mouthed horses and those that pull on one rein. Driving made safe, comfortable. Imperial Bit and Snap Co., 1320 14th St., Racine, Wis.

DISTEMPER, COUGH,

and all throat and nasal troubles cured and prevented with PRUSSIAN COUGH AND DISTEMPER CURE. It purifies the blood and tones up the system. Guaranteed. Price at dealers 50c; by mail 60c Prussian Remedy Co., St. Paul, Minn.

MACO STOPS COLIC

Scours and all intestinal inflammations in Horses, Calves and all live stock. Every stock owner should have Maco. Prompt use will save life and loss. Large 10 oz. bottle \$1.50 delivered. MAMEDION CHEMICAL CO. 307 E. 79th St., NEW YORK

No More Sore Shoulders

Never lay off your horse. This \$1.25 Lankford Cotton Filled Collar beats the world. Galls and Sores are impossible because it is an absolute fit. Light, pliable, long lasting, humane. Fits any shaped neck. Booklet tells all. Write for it, Free. THE POWERS MFG. CO., 139 Sycamore St., Waterloo, Iowa

YOUNG'S "UNO" SELF CONFORMING HORSE COLLARS

Look for the "UNO" Trade Mark. give horses collar comfort, prevent galls and sores, because the heavy facing of Young's "UNO" self-conforming mixture perfectly adjusts itself to every peculiarity and irregularity of the shoulder. They will save you money, because "UNO" Collars far outwear ordinary collars—the self-conforming mixture is backed with selected, long, rye straw—every collar has triple strength throats, heavy sole leather top pads, strong rims to hold hames perfectly—are made only of bark tanned leather cut from best part of hides—\$3.75 to \$5.00.

BRIDLE ROSETTES FREE. Write us the name of a dealer who does not handle "UNO" Collars, and we will send you a pair of beautiful nickel-embossed bridle rosettes free. BENJAMIN YOUNG, Dept. 68 MILWAUKEE, WIS.

U. Cream Separators

The modern dairymen want a Cream Separator that fulfills to the highest degree these three requirements: Close Skimming, Easy Running, Long Life. The U. S. is the only separator that combines leadership in all three of these essentials. The U. S. has received more and higher awards (acknowledging its superiority) in 1909 than all other makes combined. A request for Catalog 69 will show you all about this thoroughly practical separator and tell you all about our latest awards. Holds World's Record. Holds Grand Prize.

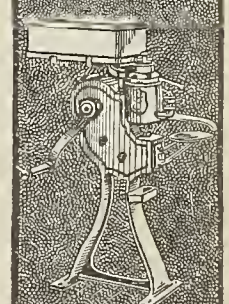

Wear Ruthstein's STEEL SHOES

Our 1910 Model

These shoes of steel, with leather uppers, are the most wonderful working shoes in existence. So economical that one pair will outlast three to six pairs of all-leather shoes—saving \$5 to \$10 of your shoe money in a year. So absolutely waterproof that you can work in mud and slush without getting wet feet and consequent colds and rheumatism. So light and resilient that your feet never ache or blister or swell. So shapely they cannot cause corns. And they cost less than leather shoes.

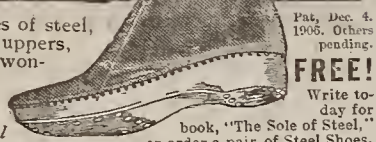

FREE!

Write today for book, "The Sole of Steel," or order a pair of Steel Shoes.

How Steel Shoes Are Made

The soles and an inch above the soles are stamped out of a special light, thin, rust-resisting steel. One piece of steel from toe to heel! The soles are protected from wear by adjustable steel rivets, which give a firm footing. Rivets can easily be replaced when partly worn off. Fifty extra rivets cost only 30 cents, and will keep your shoes in good repair for at least two years. No other repairs are ever necessary.

The uppers are made of the very best quality of soft, pliable, waterproof leather, riveted to the steel and reinforced where wear is greatest.

Steel Shoes are lighter than all-leather work shoes. The rigid steel soles prevent the shoes from warping and twisting out of shape. No "half-soleing" or patching! Steel Shoes have thick, springy, Hair Insoles, which add to ease of walking—absorb perspiration and odors. Insoles easily removed, cleaned and dried each night.

Wear "Steels"—Save Doctors' Bills

All classes of workmen can avoid colds, rheumatism, stiffness, blistered, sore and aching feet by wearing Steel Shoes. They keep the feet dry, warm and comfortable under all circumstances. The saving in medicine and doctors' bills will pay for Steel Shoes many times over. Water cannot saturate "Steels."

Steel Shoes Give Most for the Money

Sizes 5 to 12—6 in., 9 in., 12 in. and 16 in. high. Steel Shoes, 6 inches high, \$2.50 a pair; better grade of leather, \$3.00 a pair; extra grade of leather, black or tan color, \$3.50 a pair.

Steel Shoes, 9 inches high, \$4.00 a pair; extra grade of leather, black or tan color, \$5.00 a pair.

Steel Shoes, 12 inches high, \$5.00 a pair; extra grade of leather, black or tan color, \$6.00 a pair.

Steel Shoes, 16 inches high, \$6.00 a pair; extra grade of leather, black or tan color, \$7.00 a pair.

One Pair of "Steels" Will Outwear 3 to 6 Pairs of Leather Shoes

The comfort of Steel Shoes is remarkable. Their economy is simply astounding! Practically all the wear comes on the rivets in the bottoms and the rivets can be replaced very easily. Don't sweat your feet in rubber boots or torture them in rough, hard, twisted, shapeless leather shoes. Order Steel Shoes today. Sizes, 5 to 12.

Guaranteed as Represented

We strongly recommend the 6-inch high at \$3.50 per pair, or 9-inch at \$5.00, as they give the best satisfaction for general service.

In ordering, state size shoe you wear. Enclose \$3.50 for 6-inch size, and the best and most comfortable working shoe you ever wore will promptly be shipped to you. Your money refunded without delay if not found exactly as represented when you see the shoes. Send today!

Steel Shoe Co., Dept. 381, Racine, Wis.

Canadian Branch: Toronto, Can. (33) Great Britain: Northampton, England

Hatch Chickens By Steam

The most satisfactory incubators on the market are the Wooden Hen and Excelsior. They not only solve every problem of heat, moisture and ventilation, but hatch a chick from every fertile egg. The simplicity of construction and economical operation of the

Excelsior Incubator or WOODEN HEN

make them the most popular incubators—run themselves. Send for free catalogue on growing Incubator Chicks, four teen colored views.

GEO. H. STAHL
Box 5-W, Quincy, Ill.

BROODER WITH THE BEST

Bonded SURE HATCH

During this month we will send a brooder for actual half price to every person ordering a

Sure Hatch Bonded Incubator

This is the only incubator guaranteed and backed by a \$1,000,000 surety bond of the Bankers Surety Co., Cleveland, Ohio. We pay the freight.

SURE HATCH INCUBATOR CO.
Box 66, Fremont, Nebr.

Steel Shingles Save Five Times Their Cost

Lightning and Fireproof—Last a Lifetime

An Edwards "Reo" Steel Shingle Roof outwears four wood roofs and costs only two-thirds as much as one. One \$60 Steel Shingle Roof is worth four \$90 wood roofs and there's \$300 difference in cost.

A roof which could be shingled with Edwards "Reo" Steel Shingles for \$60 could be covered with composition tar roofing for \$50. But one Steel Shingle roof outwears six of the others and saves \$240.

Besides, "Reo" Steel Shingles are fireproof and reduce insurance rates from 10 to 20 per cent.

Edwards "REO" Steel Shingles

will not rust, corrode nor taint. They are stamped in sheets of best quality Bessemer Steel 5 to 10 feet long, covering width of 24 inches. Galvanized or painted.

\$10,000 Guarantee Against Lightning

Our iron-clad bond guarantees to refund amount you pay us for steel shingles in case your roof is struck and damaged by lightning.

THE EDWARDS MANUFACTURING CO., 309-339 Lock St., Cincinnati, Ohio

Practical Poultry-Raising

Solving the Turkey Riddle

WE HAVE to raise turkeys under unnatural conditions. My experience has been that the best results come from care that provides, as nearly as possible, natural conditions. Hundreds of people say that turkeys are so hard to raise that it is the most uncertain branch of the poultry industry. I used to find this true. They say the sin of ignorance is winked at, but I have an uneasy conscience when I think of being brought to judgment for the turkeys I have killed through ignorance.

The first requisite is proper care for the breeding stock. After keeping my breeding turkeys in a large field through one season I would never go back to the plan of letting them roam where they pleased and make nests where they chose. A great many farmers keep only four or five hens to breed from and they usually can set the children to watch them go to their nests; but with twenty to thirty hens it is a different proposition. If you have a large field (an orchard is best) with a wire netting fence with barbed wires above it, they can be kept at home, especially if you hobble them. Take a shingle or thin piece of board and make two holes in it near each end close to the edges. Lay this against one of the turkey's wings, and fasten it there by running soft cords through the holes and around the wing. This prevents the spreading of that wing, and hinders the bird from flying over a high fence, though it may reach a low perch. Your birds must lay inside the inclosure and you can gather the eggs every day. Put them in a cool place and turn them every day or two. I provide nests, using barrels turned over on their side, scattered about the inclosure. When your turkey is ready to sit, you can put fifteen to eighteen eggs under her and place nine under chicken-hens at the same time. I always keep the date when they begin to sit and know exactly when to expect the new brood, and have places fixed for them.

Newly Arrived Poult

Their houses are large square dry-goods boxes made of matched boards. We saw out a hole a foot on one side and tack wire netting over it. We make a lath door, fastened at the top with wooden buttons, which keeps the old turkey in and lets the young poults out. Out of the boards sawed out I make a tight door, that shuts them in securely at night. Then you have the satisfaction of knowing no marauders can molest them, except two-footed sneak-thieves, and they prefer waiting until the turkeys are raised. The ventilating netting window on the side allows the door to be shut perfectly tight and still give enough fresh air. Around the coop I make a good-sized yard out of twelve-inch boards, which keeps the poults from wandering off. When they are all hatched, I take the little turkeys in a basket, carefully wrapped up, to the house and either paint a box with liquid lice-killer and put the hen in for an hour or two or dust her all over with the lice-powder. I grease the heads of the little turkeys and dust them with the lice-powder all over. Now the little fellows are ready to begin life and have their first feed.

Some feed bread and milk in a saucer as soon as the poults will eat, some ad-

here to an absolute grain diet, while others feed everything they imagine the poults will eat. It should never be forgotten that in the wild state their food was the bugs, worms, seeds, etc., which they found for themselves, while now they are quite too often forced to eat unnatural foods that are furnished in hopes of forcing them to an unnatural growth. I have tried several methods of starting young turkeys, but have had the best results by feeding them for their first feed bread soaked in sweet milk and then squeezed dry with the hand. Then with this I mix hard-boiled eggs, ground rather fine, shells and all. Never use sour milk, nor should bread thus prepared ever be fed after it has become sour. Feed this mixture, a little at a time, every hour or so, for two or three days or more. After a few days of this, follow it with a ration of finely-broken grain (most of the commercial chick foods are excellent) and include a little finely-cut meat, which must be pure and sweet. Nothing is worse for poults than tainted or infected meat of any kind. Lean beef, well cooked and ground fine, is very good. Be very cautious about feeding green meat or bone. If any of this is fed, have it cut quite fine, giving but little at first. Cooked meat I find is better. Coarse sand is excellent for grit, and if sufficient of this is at hand no other grit will be needed; but plenty of grit of some kind is a necessity. Clean, fresh water should be before them at all times. This is an essential.

Beware of Overfeeding

Food should be given quite early in the morning and at frequent intervals during the day. Never overfeed them. Give them all they will eat up clean willingly and no more. Avoid the use of rich foods, grains in hulls and millet-seed, which is not good for them while they are young. A little of this seed, however, may be fed as they grow older. Too much hard-boiled egg is bad, while a reasonable amount with bread is beneficial. An excess has a tendency to clog the bowels, and the writer has seen poults die from the effects of a diet exclusively of egg and millet-seed. Milk curds fed alone have the same effect, though a little milk every day is very beneficial.

After the young turkeys are sixteen to twenty days old I begin to feed lightly on cracked corn, wheat, etc., and occasionally baked corn-meal or johnny-cake, which is simply corn-meal mixed with sweet skim-milk or water and a very little salt, and thoroughly baked. This is moistened slightly before feeding. When the young poults begin to get their long wing flight feathers, they require extra care and attention. These feathers seem to grow so rapidly sometimes as to sap their vitality, and when they begin to walk around with their wings drooping, I pull these flight feathers out. By the time they start again, the young birds are much further advanced, and it does not seem to affect them.

Many partly-grown turkeys are lost during wet weather, after they have been given liberty to roam at will. This may be largely avoided by keeping watch of them to see that they do not become chilled or lost. By the time the poults are six weeks old I feed more liberally on grain, and I also find it a very good plan to keep cottage-cheese or pot-cheese, in which is put onion-tops chopped fine, before them. After they shoot the red, at which time most of their troubles are over, I place clabbered milk where they can get it whenever they want it, which is an excellent feed at this time. Knowing that it is always waiting for them, they will return from time to time during the day from their foraging to eat it, and thus they form the habit of coming home at stated periods.

From this time on they are practically given their liberty to roam over field and wood, receiving a light feed of grain at night just before they are shut up. This induces them to return without trouble. From all this it will be seen that the first four weeks or so of the turkey's life is the critical time. A baby is less care, I have often thought, than a lot of young turkeys, but when in the fall they flock around for their daily ration, plump and fat with the plumage a wave of iridescence and sheen which no artist could place upon canvas, and you know that each one represents two or more big round dollars on the market, one feels amply paid for all the care, vigilance and attention bestowed upon them in their infancy.

A. E. VANDERVORT.

Blackhead in Turkeys

A SUBSCRIBER in Florida writes: "I have tried raising turkeys for two years, but I lose a great many. When they are about two thirds grown they seem droopy for several days, eating very little, then drop their wings down and bend their necks out and die. They seem very thirsty for several days before they die—droppings are very loose, yellow and green. They are fat and seem in good condition until taken sick."

From the data given I think your turkeys have a common disease among turkeys called blackhead. This is caused by a micro-organism named the amoeba meleagridis which invades the mucous membrane of the intestines and also affects the liver. If you had dissected any of the dead birds, you would probably have found that the liver was greatly enlarged, quite solid and full of yellow lumps, and that the gizzard seemed very dry and the crop full of water. The only relief is through a preventive. Where the disease has been present on a farm for some time or where a number of sick birds have been discovered, it is advisable to dispose of all the turkeys on the farm. So far as possible, disinfect the ground over which they have been running the most. One of the most satisfactory plans is to top-dress the ground with a good coating of air-slaked lime and plow it in. In starting a new flock the eggs should be from sound, healthy turkeys and hatched in incubators or under common hens. The poults should be raised or started on ground that has not previously been used for turkeys.

A number of remedies have been recommended from time to time for the cure of blackhead, but none of them have proved satisfactory. Get rid of your present flock and start new. Feed and care for them right and I think you will have no further trouble. A. E. V.

Starting the Goslings

A FEW of the points I have learned in several years of experience with geese may have value to some beginner. I raise the large gray Toulouse, or land geese, which, however, are very fond of water, though they always come to their nests to lay.

They usually begin to lay in early March, here in northwestern Ohio, though most people do not figure on hatches till later. Be careful the eggs do not get chilled, and set them as soon as possible after they are laid, five eggs to a medium-sized hen or seven to a large one, chicken-hens being much easier managed than geese. The fourth and last week the eggs should be sprinkled once a day with warm water and should be watched while hatching, as the goslings sometimes need helping. When taken from the nest they should be put in a rat-proof coop, for rats are as fond of young goslings, "as niggers are of 'possums."

Goslings will eat grass almost as soon as hatched, and will live and grow on that alone, but it is better to give them a little corn-meal, which must be salted a little. They must be sheltered from the rain until their backs are well feathered, for they down easily before that.

They grow much faster during spring than summer. They do best by themselves in a shady, grassy yard. The little ones do not care much for the hen mother, who soon becomes disgusted and leaves her unappreciative family. When full grown they should be picked every six weeks; the feathers bring seventy-five cents a pound in some markets.

MARY E. BLAIR.

Another Big Turkey

FARM AND FIRESIDE:— I think I have the turkey outclassed of which mention appeared in FARM AND FIRESIDE of February 10, 1910. It was hatched in the spring of 1908, and sold in the San Francisco market Thanksgiving, 1909; live weight thirty-eight pounds, at twenty-five cents per pound, price \$9.50.

MRS. T. S. PAINTER.
Dos Palos, California.

Unless the best of quarters can be given, chicks hatched too early in the season often prove unprofitable. Owing to the cold and wet weather of early spring they will often be outstripped in growth by those coming a number of weeks later, when the weather is more favorable.

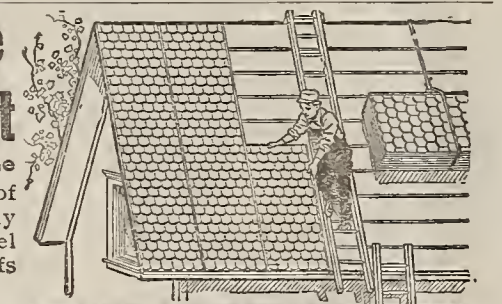

Easiest to Put On

You can lay the roofing yourself. No special tools, no soldering. Our patent interlocking device covers seams and protects nails from rust; also allows for contraction and expansion.

We Pay the Freight

We are the largest makers of Iron and Steel Roofing and quote the lowest prices, freight prepaid, on all kinds of metal roofing—Plain, Galvanized, Corrugated, V Crimp, Imitation Stone and Brick, etc.

Send for Free Catalog 339

Write today for our liberal proposition to represent us in your territory. Big opportunity.

(17)

Have You Got Johnson's Book?

He says to tell you that he has filled it with good things this year. 350 photographs in the book. Every other page a poultry sermon. The best free poultry book ever published.

His 1910 Old Trusty Incubator is covered with asbestos and again covered with handsome sheet metal. 52,000 metal covered incubators last year. Making prices to sell 70,000 this year. Don't pay two prices for untried incubators or the score of imitations of the Old Trusty. Write Johnson today and get special direct prices. 40-60-90 days' free trial. A whole year if you want it.

Johnson "the incubator man" has made more incubators than any three men in America. He knows how to make them to hatch for the novice or expert. His 10-year guarantee makes you safe. Address for book

M. M. JOHNSON, Clay Center, Neb.

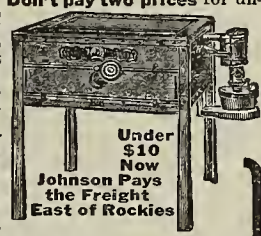

Under \$10 Now Johnson Pays the Freight East of Rockies

90% Hatches

from the Cyphers—in every country and climate—for old-timers and beginners. For you.

CYPHERS INCUBATORS and Brooders are non-moisture; self-regulating; self-ventilating. Write for 160-page Catalog. Address Nearest City.

Cyphers Incubator Co., Department 72 Buffalo, N. Y.; New York City; Chicago, Ill.; Boston, Mass.; Kansas City, Mo.; Oakland, Cal.



STANDARD CYPHERS INCUBATOR Fire Proof-Insurable

\$7.55 Buys Best 140-Egg Incubator

Double case all over; best copper tank; nursery self-regulator. Best 140-chick brooder, \$4.50. Both ordered together \$11.50. Freight Prepaid. No machines at any price are better. Write for book today or send price and save waiting. Satisfaction guaranteed.

BELLE CITY INCUBATOR CO., Box 100, Racine, Wis.

FOY'S BIG BOOK, MONEY IN POULTRY And Squabs. Tells how to start in small and grow big. Describes largest pure-bred Poultry Farm in the world and gives a great mass of useful information about poultry. Lowest prices on fowls, eggs, incubators and brooders. Mailed for 4c. F. Foy, Box 10, Des Moines, Iowa



We ship quick from St. Paul Buffalo Kansas City or Racine

Double case all over; best copper tank; nursery self-regulator. Best 140-chick brooder, \$4.50. Both ordered together \$11.50. Freight Prepaid. No machines at any price are better. Write for book today or send price and save waiting. Satisfaction guaranteed.

BELLE CITY INCUBATOR CO., Box 100, Racine, Wis.

FOY'S BIG BOOK, MONEY IN POULTRY And Squabs. Tells how to start in small and grow big. Describes largest pure-bred Poultry Farm in the world and gives a great mass of useful information about poultry. Lowest prices on fowls, eggs, incubators and brooders. Mailed for 4c. F. Foy, Box 10, Des Moines, Iowa

Lowest prices on fowls, eggs, incubators and brooders. Mailed for 4c. F. Foy, Box 10, Des Moines, Iowa

Trinidad Lake Asphalt

has no equal as a waterproofer. After we have used it for thirty years, everybody is learning its value for every waterproofing purpose.

Genasco Ready Roofing

is made of genuine Trinidad Lake asphalt.

There is no roofing substitute for Genasco—none will last so long.

Ask your dealer for Genasco. Mineral or smooth surface. Look for the hemisphere trade mark. That's a surer guide than the looks of the roofing. It is your real guarantee, but we'll write you a guarantee, if you think you need it. Write for the Good Roof Guide Book and samples.

THE BARBER ASPHALT PAVING COMPANY
Largest producers of asphalt, and largest manufacturers of ready-roofing in the world.

PHILADELPHIA
New York San Francisco Chicago

Cross-section, Genasco Stone-surface Ready-Roofing



Gravel
Trinidad Lake Asphalt
Wool Felt
Trinidad Lake Asphalt
Wool Felt



GENASCO
THE STANDARD OF EXCELLENCE
TRADE MARK
REGISTERED

Write for this FREE BOOK

This instructive, interesting book of 168 pages and 150 illustrations is free to farmers and to others interested in building. In it you will find directions—written by experts—for making and using concrete, with plans, diagrams and specifications for farm structures, such as stables, barns, piggeries, cellars, chicken houses, etc. Write for this book, "Concrete Construction About the Home and on the Farm" to-day.

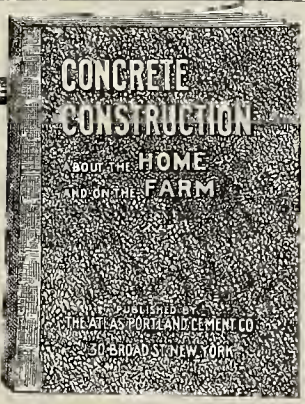

ATLAS PORTLAND CEMENT

Makes The Best Concrete

When you begin to build with concrete be sure that ATLAS Portland Cement is used, for the strength of a concrete building depends on the strength of the cement used. ATLAS is the standard American brand of Portland Cement. There is only one quality of ATLAS manufactured—the best that can be made and the same for everybody.

The United States Government uses ATLAS on the Panama Canal, 4,500,000 barrels having been ordered for that purpose.

ATLAS Portland Cement is made of genuine Portland Cement rock. It contains no furnace slag.

Ask your dealer for ATLAS. If he cannot supply you, write to

The ATLAS Portland CEMENT Co.
Dept. 122 30 Broad Street, New York
Daily Productive Capacity Over 50,000 Barrels—the Largest in the World.



NONE JUST AS GOOD

Poultry-Raising

The Poultry-Yard in April

THIS is the month when the largest number of chicks are hatched. Less artificial heat should be given than was given the March chicks. One farmer's wife quite successfully keeps motherless chicks warm through the day in a large box with glass fitted in the top. This is set in the sun and gives comfortable shelter when the wind is cool. April chicks should be allowed to run out during the day upon ground free from filth and protected from preying animals by small meshed wire. This ground should be covered with a growth of clover or rye sown the previous fall. Another fenced run should be sown with oats early in April. In about two weeks the first run will be unfit for use and the second will be in fine shape.

A satisfactory arrangement is a row of coops dividing a pen in the middle, one side sown to clover and the other to oats. The coops have doors at each end, those admitting them to the clover pen being open. When advisable to admit them to the oat-sown section, the doors on the opposite side of coops are used.

For a flock of forty or fifty young chicks with mothers, three coops and two runs each six by twelve feet are needed. Shallow boxes of sea-shore sand furnish excellent grit for young chicks. Do not give much moist feed the first week after hatching. Equal parts of cracked wheat and cracked corn

and chopped cooked egg three times a day is a satisfactory diet. When the chicks are two weeks old, the noon feed may be a mixture of one third bran, one third corn-meal and the remaining third of equal parts of linseed-meal, beef-meal and charcoal, the entire mixture being fed in a moist, crumbly state. Hot milk or hot water is used to moisten it. At night the feed should be whole wheat and cut clover. Parched cracked corn prepared by ten minutes' exposure to oven heat may be fed in equal portion to the wheat at night.

If lice appear, the coops should be whitewashed with lime and sulphur, and the bodies of the chicks dusted with some good insecticide not injurious to chicks.

If chicks are mothered in the usual way, the hen will come into good laying condition on the same rations which the chicks receive and ought to begin laying in three weeks after hatching her brood without interfering with her maternal duties.

M. ROBERTS CONOVER.

Promising All-Purpose Fowls

THE Cornish Fowl is a comparatively new breed being a cross between the Jungle fowl of India and the English Game. The standard weight of the cock is nine pounds; hen, six and one half. The Cornish is a quiet peaceable bird, altogether different from the so-called Pit Game. The old name, "Cornish Indian Game," was applied to them because they descended from the India Wild Fowl and originated in Cornwall, England.

The Cornish is one of our best all-purpose breeds. From a practical stand-



A Typical Cornish Cock of Imported Ancestry

point, as a farmer's chicken, they have proved to be good egg-producers and stand in the front rank as table fowls, the meat savoring of wild game. They have a low, pea comb which will not freeze and a small amount of feathers. The Cornish hen lays an egg as large as the Plymouth Rock and weighs about twice as much as the Leghorn.

The "Cornish Indian Games" of the past were tall, thin and small-bodied, and generally conceded to be of no account. But the Cornish standard has changed, and in recent years many typical specimens imported from England have improved the flocks in this country. The present-day Cornish chicken has a wedge-shaped body with a deep, full breast; broad back; short, thick shanks set well apart, and a short, low tail. The bird in general is compactly built, vigorous and majestic looking.

The hens make very fine sitters, and watch and protect their young at the risk of their own lives. The chicks are quick growing; at ten weeks of age they have been made to weigh three pounds. They are also extremely hardy, and will live and thrive by self-support, if allowed.

Farmers hunt for the best breed of hogs, horses or cattle, and it is just as important to hunt for the best farm chicken. I have bred nearly every kind, but like the Cornish best of any I have ever handled, and I believe that in a few years it will be seen as a common barn-yard fowl.

F. E. VANDERHOOF.

Gritty grit is the only stuff for hens. Some of it is too smooth to grind much food for your biddies.

With poultry and eggs at present good prices there are but few farmers who will not admit that they would rather have them to sell than to buy.

AMERICAN FENCE

Made of Hard, Stiff Wire, of Honest Quality

Fences Cost the Least and give the most returns of any improvements on the farm

Look around and see the farmer who has money in the bank and who buys another quarter-section every few years. See his farm—it is fenced hog-tight. What is good for him is good for you. Enough feed is wasted on the average quarter-section of unfenced fields to feed a large drove of hogs.

Any American Fence dealer will quote you figures that may astonish you on fencing your farm with heavy, hog-tight fence. You have no idea how little money it takes, considering what you will actually save.

American Fence is made of hard, stiff steel. It is made of a quality of wire drawn expressly for woven-wire-fence purposes by the largest manufacturers of wire in the world. Galvanized by the latest improved process—the best that the skill and experience of years has taught. Built on the elastic, hinged-joint (patented) principle, which effectively protects the stay or upright wires from breaking under hard usage.

The real test of a fence is the service you get out of it. Test, judge and compare American Fence under any and all conditions and you will find that the steel, the structure and the galvanizing are equal in durability, strength and efficiency to the hardest usage.

F. Baackes, Vice-Pres. & Gen. Sales Agent
American Steel & Wire Co.
Chicago New York Denver San Francisco

NOTE—Dealers Everywhere. See the one in your town and have him show you the different designs and give prices. Also get from him booklet entitled "HOW TO BUILD A CHEAP CONCRETE FENCE POST," furnished free for the asking.

At Last, the Perfect Incubator

100 EGG INCUBATOR \$7.00
100 Chick Outdoor Brooder \$5.00
BOTH, FREIGHT PAID \$10.00

The Advance—Took 20 years to perfect. Thousands now making money with 310 outfit, raising for market—breeding—selling. Copper tanks, double walls, self-regulating lamp and thermometer complete. Its equal for the money does not exist. Order direct, or full description free for postal.

ADVANCE MFG. CO.
Box 85, Dayton, Ohio.



Send Us a Postal for a Price

Just your name and address on a postal brings special low prices on all sizes of

RACINE Incubators and Brooders

—guaranteed to hatch highest percentage of eggs. Liberal Trial Plan. Best Incubator Proposition on the market. Postal brings all printed matter and special prices at once. Address

RACINE HATCHER COMPANY
Box 96, Racine, Wis.



Asbestos and Metal Covered

125 Egg Incubator \$10 and Brooder Both \$10

If ordered together we send both for \$10 Freight paid east of Rockies. Hot water, copper tanks, double walls, double glass doors. Free catalog describes them.

Wisconsin Incubator Co.
Box 79, Racine, Wis.



120-EGG IDEAL \$7.50 Hatcher—Freight Paid

Other sizes (also Brooders) very low. Metal-covered all 'round. Safe; simple; guaranteed. Delivered free east of Missouri River and north of Tennessee. If further, write for delivered price. Get poultry guide, free.

J. W. Miller Co., Box 31, Freeport, Ill.



GET FREE BOOK

THE GUARANTEED ROOFING- CONGO

A SURETY BOND with every roll



Congo is the only ready roofing carrying a National Surety Bond in every roll.

These Legal Bonds absolutely guarantee your roofs for 10 years if covered with Congo 2 or 3 ply. We know from experience that it is probable you will get even longer service.

The National Surety Company is one of the best known insurance companies in the country. They have over \$2,000,000.00 assets.

It is therefore a matter of keen satisfaction to us that they are willing to stand behind Congo.

Of course we have to pay them a regular insurance premium. We are glad to do this, however, because we feel satisfied that we will more than get our money back in increased business.

We feel that when the people of the country realize that we are willing to back up Congo with an honest and legal Guarantee they will buy Congo—and Congo only.

If you will send us your name and address, we will be glad to send you samples of Congo and a copy of the Surety Bond so that you can see exactly how liberal this offer is. Write promptly.

UNITED ROOFING AND MFG. CO. 553 WEST END TRUST BLDG.
Chicago San Francisco PHILADELPHIA, PA.

Farm Notes

Plan for Better Oats

How to improve the oats crop is a problem. Oats are not highly profitable, yet we should secure the largest possible yields until we are able to substitute a better crop in the rotation.

In the average stock-farm rotation, oats succeed a cultivated crop, and the many failures are not surprising when we consider the preparation of the ground, the kind of seed sown and the haphazard system of seeding. Inferior seed reduces the yield every time. The cost of improved seed is very low compared with its good results. Good seed does not necessarily mean high-priced seed, but good, plump and vigorous oats that will make a rapid growth early. We seldom see a large crop from a field that makes a slow growth in the spring.

Sowing oats from the bin is expensive and undesirable. At least thirty per cent should generally be taken out. The light oats mostly fail to germinate, or produce weak and delicate plants. Here the fanning-mill is a necessity, not a luxury. As much labor is required to sow light seed and harvest a poor crop as to sow good seed and harvest a good crop. Run the seed through the fanning-mill two or three times, so that only large and plump seed will be left for sowing.

If thirty per cent of the oats in the bin are unfit for seed, the farmer who is sowing one hundred bushels is throwing away thirty bushels which he might use for feed. If he sowed thirty bushels of good seed instead, the improvement in the one year's crop would pay for the fanning-mill and cleaning.

Actual experiments show that the yield of oats may be increased from ten to fifteen bushels to the acre by the use of large, plump seed-oats. The fanning-mill removes not only the light oats, but the weed-seeds. This is especially important when we are buying seed-oats. It does not do to take chances of buying new weeds at the same time.

Smut in oats frequently reduces the yield more than six per cent. It can be prevented by the formalin treatment, which is simple, effective and inexpensive. One pint of the formalin (formaldehyde forty per cent) mixed with forty gallons of water will treat forty bushels of oats. Spread the oats five or six inches deep on a tight floor. Then add the pint of formalin to a barrel containing forty gallons of water. Use a sprinkling-can and shovel the oats while the mixture is being applied so that each oat will have a thorough and effective treatment. After the application of the formalin mixture, shovel the oats into a long pile and cover with canvas, blankets or sacks and leave the pile covered for eight or ten hours to prevent the formalin evaporating. After removing the cover spread the oats on the floor and shovel them over frequently so that they will dry out rapidly.

The amount of oats to sow to the acre depends on various conditions, such as the quality of the seed, the manner in which the ground has been prepared, the fertility of the ground and the methods of seeding. The less the amount of seed sown, the more the plants tiller—Nature attempts to make a full stand. However, I prefer a thicker stand, for I believe that the straw that grows direct from the seed possesses more vigor and produces larger and heavier heads of grain.

On a well-prepared oats-field containing plenty of available fertility, I would recommend the use of three and one half bushels of cleaned seed to the acre. The largest crop of oats that I ever raised averaged eighty-three bushels to the acre on a ten-acre field. This crop resulted from sowing three and one half bushels of cleaned seed to the acre. However, if we are sowing grass or clover seed with the oats crop, the seed will be wasted if we sow the oats too thick. It is more profitable to be content with a lighter yield of oats and secure a good seeding of clover or grass. This is one of the reasons that prompted me to substitute winter wheat for the oats crop in the rotations practised on my own farms.

The ideal seed-bed for the oats crop is secured by thoroughly disking and harrowing a potato or corn field early in the spring. Never give the field one disking, or the crop will be uneven and show streaks, or never try to remedy this by cross-disking, or the streaks will show both ways. The best method is to drive so that the disk harrow will overlap one half, allowing the outside disk to turn the small narrow strip left in

the center. This should be followed by a thorough harrowing, the more thorough, the more ideal the seed-bed will be established. Fall-plowed land should be given about the same treatment, although it will not usually need as much working.

On spring-plowed ground a firm and compact seed-bed must be established before the oats are sown. When grass and clover seed are sown with the oats, a roller is essential, followed by a light smoothing harrow to crush the lumps and level the surface.

On soils containing an excess of nitrogen or where stable manure has been applied the oats crop often lodges. We frequently hear farmers complain that their soil is too rich for the oats crop and that this causes oats to grow so large they lodge. These men are harboring a great fallacy, for the fact is that their soil is too poor, it lacks the essential element necessary to give strength and stiffness to the straw. The generality of soils on farms where grain crops are grown are deficient in mineral fertility. Phosphoric acid enters largely into the formation of the grain. Potash gives strength to the stalk and prevents the lodging of the grain. It is because the soil lacks potash and not because it is too rich that often causes failure with the oats crop. On the average farm I believe that it is profitable to apply a fertilizer carrying considerable potash to our oats ground.

W. MILTON KELLY.

Elevators Run at Cost

YOUR editorial of January 25th about Canadian elevators is the most important item I have seen in FARM AND FIRESIDE for some time.

Last summer I recommended to the city council of this city—Bowling Green, Ohio—that it was not best to force manufacturing, but, instead, to build an elevator and to buy and ship grain and live stock at cost. This good market would bring the people to town for twelve to fifteen miles and do more for the small city than the one hundred thousand dollars that has been spent here for factories and other improvements, as some of the factories have burned and gone out of business, some have failed and some have pulled up and moved to another city for more bonus, while some small factories still remain here.

These run-at-cost elevators are good for the farmers; now suppose we make them good for all the people. Let the elevators grind the different kinds of grain and retail the flour at cost, and butcher the animals and sell the meat at retail at cost; this would reduce the cost of living about forty per cent. This would help all classes and bring the good times we are all looking for.

M. E. WOODBURY.

Such letters as the above indicate the intense interest of the people in the matter of economical marketing. We need not suggest the improbability of any ordinary town's adopting the idea in the letter, nor the doubts which must arise as to both the practicability and the legality of the suggestion. It emphasizes the necessity of better marketing systems, however, and we gladly publish it for the stimulus it contains. The farmers must get together and make their own systems of cooperative marketing. The towns and villages will not, and probably cannot, do much more than to give incidental aid and moral support. EDITOR.

The San Jose Scale

[CONTINUED FROM PAGE 4]

solutions or other spray during the summer to clean off the soft scale, by fumigating strictly according to state rules and in many cases by voluntary additional dipping of the stock in standardized soluble oil solutions, reduces to a minimum the chances taken by the buyer of nursery stock.

To any person who is asking the question that heads this article and who is hesitating about planting or buying orchards for fear of the San Jose scale, my advice will be that of the summer girl who sat on the sea-shore in the gloaming of the last day of the season beside the man whose attentions she had been cultivating for some weeks. Turning her head temptingly, she asked, "Were you getting ready to kiss me?" "Why—why, NO." "Then, why did you pucker up your mouth?" "I got some sand on my tongue." "You had better swallow it and get it in your system."

BROWN FENCE

STOUT—STRONG—DURABLE—CHEAP

Let us prove to you that Brown Fence will outlast any other because of heavier wires and heavier galvanizing. Investigate before you buy. 160 styles for all purposes. 15c per rod up—We Pay the Freight. Send today for prices and free sample of all No. 9 Rust Proof fence. The BROWN FENCE & WIRE CO., Dept. 21W, Cleveland, O.

SAMPLE FREE



4.50 Buys Best All-Steel Farm Gate

Cheap as wood. Lasts a lifetime. 12 ft. long; 54 in. high. Resists all kinds of stock. Also Farm Fence, Ornamental Wire and Wrought Iron Fences. Catalogue free. Write for Special Offer. The Ward Fence Co., Box 306, Decatur, Ind.

Get This Money Making American

SAW MILL



We have a size to suit your power and requirements. Get one of these guaranteed outfits now. Lumber is high. The mill will soon pay for itself. No experience needed. No Belts, Springs or complicated parts to get out of order or cause trouble. The sawer has complete control of Variable Friction Feed with one hand; slight motion of lever changes speed. Other time and labor saving devices enable this mill to saw more lumber with less power and less help than any other. Free Mill Book explains and lists our complete line of wood working machinery. Write for it today.

AMERICAN SAW MILL MACHINERY CO.
130 Hope St., Hackettstown, N. J. 1576 Terminal Bldg., New York

— GET THE — RIGHT ENGINE ON FIRST PURCHASE

YOU don't want to experiment with an engine. It's too expensive. Buy right the first time and your power troubles are over—at once and for all. The engine question isn't a hard one to answer—if you investigate thoroughly. For you will find I H C engines far superior. Others cannot compare in efficiency, simplicity, economy and strength.

Profit by the experience of those who are discarding other engines for the I H C. Buy an I H C first—and save the cost of a "one year" engine.

I H C Gasoline Engines

There is one to meet your needs exactly. For the I H C line offers wide choice. Ask the local I H C agent to tell you about these styles and sizes. I H C Vertical engines—made in 2, 3 and 25-horsepower; Horizontal (portable and stationary) in 4, 6, 8, 10, 12, 15, 20 and 25-horsepower; Famous air-cooled engines—in 1, 2 and 3-horsepower; Hopper-cooled—in 2, 2½, 3, 4, 6 and 8-horsepower; also sawing, spraying and pumping outfits.

International tractors have been successful in every contest, winning the highest honors at home and abroad—an ideal plowing and general purpose tractor—made in 12, 15 and 20-horsepower sizes.

Whichever I H C engine you buy will save you a world of time, work and money. You can find no better power to run the cream separator, wood saw, feed cutter, churn, grindstone, fanning mill, corn sheller, thresher, shredder, and the many other machines on your farm. There is no better power to pump water. And the I H C does these things quickly, surely and cheaply. It's the engine that pays for itself—and pays the biggest dividend on its cost. Investigate. Then judge for yourself. See the I H C dealer in your town. Or, if you prefer, write direct to us for catalogues you are interested in.

International Harvester Company of America Chicago U S A
(Incorporated)

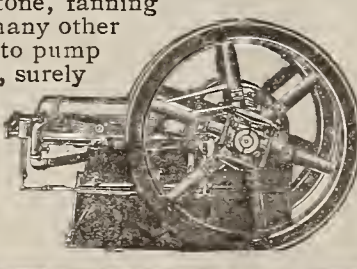

I H C LINE

Farm Notes

The Simple Secret of Big Corn and Wheat Yields

FOR the benefit of others, I wish to outline what I have demonstrated in connection with corn and wheat raising. My father-in-law owned this farm for twenty-five years and his last crop of corn was one hundred and thirty-three bushels (of ears) per acre. He was considered the best corn and wheat farmer in the vicinity. He scored deep and planted deep, cultivated once with harrow, twice deep with the two-horse cultivator and once shallow. I have produced on the same farm over one hundred and fifty bushels per acre (of corn in the ear—not shelled corn).

It is of the utmost importance to have good seed. It is well to plow deep and bring up a small amount of subsoil or new ground when plowing for corn. I harrowed thoroughly and scored two thirds the depth I plowed. The corn came up in fine shape. It was the best stand of corn in the township, according to the testimony of the supervisor, a neighbor farmer. I cultivated four times with the two-horse cultivator and part of it once with the one-horse cultivator. The results demonstrated that shallow cultivation was the proper thing. After husking was done I had every crib full and lots of other places. I had another field which produced above one hundred bushels per acre. I planted this corn one grain to the hill, eleven inches between the hills.

Now I wish to describe what I believe was the largest corn crop ever raised in Pennsylvania or elsewhere from ten acres and how it was obtained. John Sheaffer, a neighbor, produced it.

His land has been well manured, then seeded to wheat and allowed to remain in grass two years. It was then manured and plowed in the spring, then given a top-dressing of manure and a light application, about forty bushels, of lime per acre (lime burned in stack). It was planted as soon as possible, two grains per hill, twenty-two inches between hills, and cultivated three times to an ordinary depth, not deep. It was the grandest field of corn I ever saw, stalks ten to twelve and a half feet high and nearly twice as large in diameter as other corn in the neighborhood.

There were, practically, no "nubbins," or small corn. The oldest husker carried a small hatchet to chop off the ears he could not break. They had from twenty to thirty rows of grains on the cob, and the cobs were as large after the grain was removed as most corn is with grain on. The yield was twenty-five hundred and fifty bushels from the ten acres, or two hundred and fifty-five bushels per acre of ear-corn. If that is not raising corn, what is?

Relative to wheat, I never could raise a fine large crop of wheat from sowing one and one half bushels per acre. So I began experimenting. I sowed two bushels and found it increasing the yield. Then I tried two and one third bushels and raised thirty-five bushels per acre. The average before had been twenty bushels, farming otherwise in the same manner.

Now I am beginning intensive cultivation. I harrowed my wheat-ground five times, rolled it twice and dragged it twice, and I wish I could have gone over it ten times more. I had it in magnificent condition for sowing, but we cannot get the seed-bed too good or fine for wheat. The whole secret of good wheat is: The best seed, the best fertilizer and the best seed-bed.

JOHN M. H. WISE.

This letter from Perry County, Pennsylvania, is very interesting, as showing what a good farmer has actually seen and done. His doctrine of shallow cultivation is in line with the best thought everywhere. Thousands of farmers grow good corn until late in June and then half kill it by deep plowing—mistakenly thinking they are doing a "good job." Mr. Wise's experience in thick sowing of wheat accords with the experiments of the Ohio station, where increasingly better yields were obtained with the increase of the seed sown, up to ten pecks. But our friends in the drier West cannot accept the same standard. Mr. Campbell, the Dry Farming apostle, gets his best results by sowing from half a bushel to three pecks per acre, though at the Dry Farming Congress Mr. Fairfield of Lethbridge, Alberta, gave experiences showing better results by thicker sowing. A thick-sown crop passes moisture into the air too rapidly, in the arid or semi-arid belt. Elsewhere, however, it seems as if the standard our fathers used can be increased, with profit.

EDITOR.

Tuberculosis on the Farm

[CONTINUED FROM PAGE 3]

be emphasized is that such an animal, although apparently in the best of health, may be all the time spreading the disease.

Herds infected with tuberculosis may be converted into healthy herds in two ways. The most rapid method is the slaughter of all animals which react to the tuberculin test and the substitution of animals which have been shown to be free from the disease by this test. It must be remembered always that the barn in which animals suffering from tuberculosis have been kept is infected with the germs, and if new animals are put into such a barn before it has been thoroughly cleaned and disinfected, these animals will almost surely contract the disease in a very short time. In every case, therefore, in which tuberculous animals are taken out of a barn, the barn should be thoroughly cleaned, well aired and disinfected. It is also a necessary precaution to test new animals within six months and get rid of those which may react. Retesting of the entire herd must also be done. I know of some very fine herds which were badly infected, but which have been thoroughly cleaned out by this method. It is expensive, however, if only first cost is considered.

In Denmark, Professor Bang has devised a method which goes by his name, which is equally efficient and less expensive, though it is much slower. When a cow is found to be suffering from tuberculosis, it is removed from the rest of the herd and kept in a barn where only tuberculous animals are allowed. Calves born of such cows are removed from their mothers immediately after birth and are reared on the milk of healthy cows or on milk which has been sterilized. In this way healthy animals are raised from quite badly-diseased mothers.

The whole method depends upon the fact that tuberculosis is not inherited, as so many people believe, but is a disease which gains entrance to the system after birth. The milk of tuberculous cows may be used for many purposes if properly Pasteurized or sterilized.

Bang's system has worked remarkably well in Denmark and many farms which were badly infected now have entirely healthy herds without any great expense having been incurred. A number of states in this country allow this system, but it is seldom practised because of the indemnities paid by the government in this country for condemned animals and because of the expense of operating two barns. With the increase in population of our country, it is probable that this system will come more into use.

I have not spoken of the danger to mankind from the use of milk containing the bovine germ. This subject will be discussed in a subsequent paper. At present it is enough to say that the subject has been thoroughly investigated in Germany and England by governmental commissions, both of which have found that the bovine germ causes a considerable number of deaths in children; and in America and several other countries private workers have demonstrated the same thing.

The points which I would like to insist on in this discussion are as follows:

First, tuberculosis is a communicable disease. Every case arises from some other case, just as surely as every oak tree has its origin from some other oak tree.

Second, the germ of the disease is well known. We understand how it is thrown off from the body of the diseased animal and how it gains entrance to the body of the well animal. The methods of prevention are well understood, and are fortunately not difficult to carry out.

Third, a diseased animal is always a menace to the health of all other animals in the herd.

Fourth, the disease may not show itself plainly in an animal, but the animal is none the less dangerous to its fellows.

Fifth, tuberculosis of swine is becoming more common every year and has its origin almost invariably from the disease in cattle.

Sixth, healthy herds should be maintained, not only because they pay better, but also because diseased herds are dangerous to human health.

* * *

The practical farmer measures all that he hears, reads and sees, and then uses his best judgment when putting this combined knowledge to practical use. His contributions to the agriculture press are read with interest, for he knows what he knows, and says what he does.

WM. M. K.

Amatite ROOFING



The Roof for Hard Use!

PROBABLY no ready roofing but Amatite would give any satisfaction under such conditions of exposure as on the roof of the American Sanitary Works, illustrated herewith. The smoke of the railroad and from the factory's own stack, the heat and the fumes incident to the manufacture of sanitary ware, especially the heat of the kilns, all combined to test a roofing to the utmost.

In 1905 this factory was roofed with Amatite—15,000 square feet of it. Four years later the manufacturers write us as follows:

"Washington, N. J.,
June 17, 1909.

Dear Sirs:—We have used your Amatite Roofing for the last four years and are pleased to recommend same, as we think it is the most durable roofing of its kind in the market to-day. We placed it on a dry kiln about four years ago, which is a severe test on any roofing material, and it has given perfect satisfaction. Having built a new kiln this year we used the same material. We have also used it on the addition to our factory which was built this year.

Yours very truly,
AMERICAN SANITARY WORKS.
H. A. MAYO, Asst. Treas."

Undoubtedly any ordinary ready roofing would have required painting at least every year under these conditions. Amatite, however, never requires painting because it has a mineral surface which is better and more durable in every way than paint could possibly be.

That is the way a roof ought to be made. A roofing which has to be painted every little while so that it will not leak is no roof at all. Any kind of paper or cloth could be used for a roof if you were content to paint it often enough and thick enough. The paint on ordinary roofings constitutes the real roof.

Next time you need a roofing, remember that it is now possible to buy Amatite, which needs no painting. Remember also that Amatite, despite its "no-paint" feature, costs no more than other ready roofings.

Free sample on request.

BARRETT MANUFACTURING COMPANY

New York Chicago Boston Philadelphia St. Louis Cleveland Cincinnati
Minneapolis Pittsburg New Orleans Kansas City London, Eng.



HIGH SPEED CONCRETE TILE MACHINE \$41⁵⁰

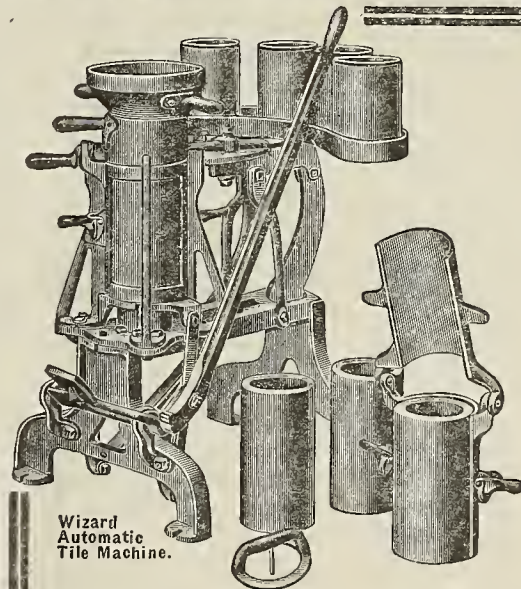

Wizard Automatic Tile Machine.

UNDER ACTUAL TEST two of these Wizard Tile Machines operated by five men have turned out as many concrete tile in one day as the big \$1,000 machines which require an engine and seven men to operate. A day's output of the Wizard Tile Machine is from 900 to 1,200 perfect tile 10 inches long with 4-inch opening and 5/8-inch wall, and selling readily for 7 cents each. \$63.00 to \$84.00 is the value of your day's product, and the profit above cost of material and labor is about \$35.00 a day.



The Wizard Block Machine. Fastest and best on the market.

Wizard Automatic Block Machine, \$42.50

The only really successful and by far the fastest automatic block machine on the market, sold at less than half the price others charge for inferior machines. Guaranteed to make perfect blocks on the face down principle. Faster than any other machine sold.

Our Triumph Block Machine at \$16.95 is by far the best low priced block machine on the market.

Fence Post Molds

Our Fence Post Molds, making concrete fence posts either by semi-dry or slush system, are the best molds on the market and are sold at lower prices than ever before asked for a practical mold.

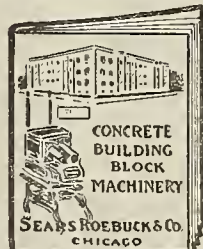

Send today for Concrete Catalog No. 71F36

Write for This Free Catalog

Handsome molds for post columns, piers, balusters and capitals. A full and complete line at record breaking low prices. We sell more concrete block machines, molds and supplies than any other concern in the world. Our catalog tells the story. It is the most complete book of information on concrete machinery, whether you are contemplating concrete building for yourself or for others. This book shows you how to save money on your own concrete buildings and how to make a profit in the concrete material business. We will send it free on request the very day you ask for it.

Triumph Fence Post Mold. \$7.95

Sears, Roebuck and Co., Chicago

SUBSCRIPTION PRICE

One Year (24 numbers) 50 cents
Canadian Subscriptions . 1 Year, 75 cents

Entered at the Post-Office at Springfield, Ohio, as Second-Class Mail Matter.

Subscriptions and all editorial letters should be sent to the offices at Springfield, Ohio, and letters for the Editor should be marked "Editor."

The date on the address label shows the time to which each subscriber has paid.

Subscribers receive this paper twice a month, which is twice as often as most other National farm journals are issued.

Silver, when sent through the mails, should be carefully wrapped in cloth or strong paper, so as not to wear a hole through the envelope.

When renewing your subscription, please say it is a renewal, and if possible send the label from a recent copy. If all our subscribers will do this a great deal of trouble will be avoided.



PUBLISHED BY

THE CROWELL PUBLISHING COMPANY

SPRINGFIELD, OHIO

Branch Offices: 11 East 24th Street, New York City

Tribune Building, Chicago, Ill.

Copyright, 1910, by The Crowell Publishing Company

ABOUT ADVERTISING

FARM AND FIRESIDE does not print advertisements generally known as "readers" in its editorial or news columns.

Mention FARM AND FIRESIDE when you write to our advertisers, and we guarantee you fair and square treatment.

Of course we do not undertake to adjust petty differences between subscribers and honest advertisers, but if any advertiser in this paper should defraud a subscriber, we stand ready to make good the loss incurred, provided we are notified within thirty days after the transaction.

FARM AND FIRESIDE is published on the 10th and 25th of each month. Copy for advertisements should be received twenty-five days in advance of publication date. \$2.00 per agate line for both editions; \$1.00 per agate line for the eastern or western edition singly. Eight words to the line, fourteen lines to the inch. Width of columns 2 1/4 inches, length of columns two hundred lines. 5% discount for cash with order. Three lines is smallest space accepted.

Letters regarding advertising should be sent to the New York address.

Coal and Congress

A COUNTRY without coal could not remain civilized according to our present standards. In a way our national life must flourish or decline as coal is plentiful and cheap or scarce and dear. Our houses, our machinery, our clothing, our food, our paper, our books, our travel, our commerce, all are manifold expressions of power derived from coal. Most of us buy coal as coal; all of us buy coal already burned as expressed in things manufactured, and we all sell things the value of which is determined by coal to be burned in transportation and manufacture. Hence no substance is more important to us all than coal.

We, as a nation, own vast bodies of coal. We have sold to private parties for almost nothing great areas of coal-lands, but we have much left. A long time ago a law was enacted authorizing the sale at not less than thirty dollars an acre of coal-lands if within fifteen miles of a railway, and at not less than twenty dollars an acre if more than fifteen miles. Notice the words, "not less than." Our land department adopted the astounding rule that this meant "not more than." Even though we know this to be true, it seems incredible. If a person should send an agent to market with a car of fruit with instructions not to sell at less than five dollars a barrel, and he should refuse to accept more than five dollars, no matter what the market price might be, we should say without a moment's hesitation that the man was insane, idiotic or bought.

Roosevelt and Garfield changed that, by having the coal-lands classified and sold on the basis of the coal in them. But even under this new and more justifiable plan, the coal will be in great part lost to us. It is being sold at a few cents a ton, and only that already discovered can be sold. All of which we do not know is lost to us. All increases in price are lost. It should not be sold at all. It should be kept by the government and mined by lessees who would pay a royalty on each ton dug. The government could keep it out of the hands of coal combines by this plan, and coal from the government mines would compete with other coal and we should all be delivered from the clutches of monopoly. Coal would be more plentiful and cheaper, and all our lives fuller, easier, more highly civilized.

The administration "conservation bill" provides for just this system of holding coal-lands and having them worked on lease. It is a bill that the President asks passage for. The people who want to monopolize coal, who have been getting lands for "not more than" when the laws says "not less than," and who are now getting it for a few cents a ton for that only which has been discovered, are opposing the conservation bill. It is rumored that the administration does not much hope to pass the measure this session.

But public opinion may demand its passage so loudly as to force the hand of a reluctant Congress. This editorial will probably be read before Congress adjourns. If so, every reader may do something to impress upon congressmen and senators the fact that public opinion is awake. Public meetings may be called. Resolutions may be passed. Letters may be written. All these things should be done. Nothing could be better for the nation than for the very hills and roadsides and prairies to take fire with indignation at the very thought of a failure to pass this bill. It may be the privilege of some reader of this to set in his own neighborhood the fire, which shall so grow as to tinge with red the western sky, as seen from Washington, with the flame of the righteous passion of a people whose dearest rights have been trifled with too long.

* * *

Hurry is the worm that eats the heart out of many of our farm operations. Just one more time across with the harrow, a little more time taken with the plow, a trifle more of care in carrying out what seem small details—these will bring better crops, better soil conditions and better success generally.

Some men by the care and earnestness they put into their work will do better farming with an old tool than others will with the most costly implements. It is the man and not the machine that counts.

Nowadays we employ highered help.

Gullies are like hollow teeth—need filling.

One of the fates, at least, is friendly to the farmer—phosphate.

The man who tries to do better than the average raises the average.

There is a difference worth noting between the high cost of living and the cost of high living.

The farmer who makes love to Mother Earth and caresses her with proper tillage will win her best favors.

The farmer who robs the soil may be immune from legal punishment, but not from ignominy in the hearts of posterity.

Are you going to farm this season "hit-or-miss" fashion, or are you reducing your efforts to a system? The first means more labor and less returns; while the other will require less physical effort, with greater profits. Take your choice!

Do These Things Mean Invasion?

IS THE country about to be invaded by a migration from the city to the farm? If so, what is the significance of the movement—if there is such a movement—to us who are already on the farm? That the "back-to-the-land" cry in this country has deeply affected the minds of thousands in every large city, as well as many in small towns, there can be no doubt. That the space which has been recently given in the press to puffery of the profits of farming is filling perhaps millions of minds in city skulls with deceptive dreams of opulence from farming, and that it has vastly and unfortunately accelerated the "back-to-the-land" tendency, must be true. And when city schools begin to teach agriculture, and city night-schools take up the same science, we may as well sit up and take a little notice of a threatened invasion of the plowed fields from the pavement.

The Bedford branch of the Young Men's Christian Association, of Brooklyn, New York, is now giving a course of twelve practical lectures on country life for city men. The best specialists in the country are telling these town people how and where to locate, the equipment they will need, teaching of the soil and its fertilization and its improvement by mechanical means, demonstrating in a lesson on fruit-growing how to graft, prune and bud and manage an orchard or a small fruit-patch, how to lay out, plant and handle a vegetable-garden, and how to fight garden pests. There are two lessons on poultry-raising, one on live stock, one on dairying, one evening devoted to practical suggestions for beginners and one to first-hand reports of individual successes—a regular farmers' institute.

Of course, these twelve lessons will not make a farmer; but with the Saturday-afternoon trips to farms near New York City, the course will give the greenest beginner a push toward farming. It will make the man who has been making the best use of his back yard for a few years a better man in his specialty than is many a man who is making a living from the soil, and render him better equipped for doing business on a larger scale than the "sure-enough" farmer might at first be willing to believe.

The fact that the cities are stirring with this tendency to return to the farms is of great significance to us as farmers. Much of it will disappear when the present false notions as to the excessive profits of farming are dispelled by time; but back of it all there seems to be a real impulse which is likely to move large bodies of people.

Well, if they come to the farming neighborhoods with more progressive ideas than we have, it will help us. If they come needing help, we should be ready to help them. And we should see to it that they are not permitted to become the exclusive possessors of scientific agricultural education. We should see to it that our rural schools are as much farther advanced in agricultural teaching than the city schools, as they are more important to the business of farming. That duty rests on us. Are we doing anything to discharge it?

Get Ready for the Corn Crop of 1920

HERE you have ten ears of seed-corn that look equally good. You have selected them with care from the stalk, so as to get the progeny of good individuals. You believe in good breeding in corn as in cattle, and you think you have done your duty. Yes, you believe—but is it that sort of dynamic belief that never rests until it is worked out in practice?

If you plant those ten ears of corn, thinking that they will bring you returns as uniform as their appearance, you have only a kind-of, sort-of belief in corn-breeding. As a matter of fact, you cannot tell within thirty bushels of corn to the acre which is the best seed. There is an old adage that you have to summer and winter with a man before you know him, and it holds good in a still greater degree with corn. There may be in that group of ten ears one that will bring you three times the yield that the one lying beside it will bring. The only way to tell is to plant the ears separately, and see.

The corn-breeders of the Minnesota Experiment Station out of six uniformly good ears got a yield under identical conditions at the rate of 57.8 bushels per acre from Ear No. 6, and 82.9 bushels from Ear No. 1. Correcting the result by taking into account the greater percentage of marketable corn in the best ear, the difference was thirty bushels per acre. Mind, this was not the difference between good and bad seed, but between two ears of apparently good seed. Every farm should have its ear-to-row breeding-plot, and every farmer should summer and winter with his seed-corn, and know for years back what the ancestors of his corn have done. Lots of trouble? Yes—but think of the trouble of growing that odd thirty bushels with inferior seed. Can you think of any easier way to double your yield, with the same work, in the crop of 1920?

* * *

Better to have a good grip on yourself than to have a tight grip on the money-bags.

The kind of farmer who combs his hair only when going away from home or receiving company usually carries his horses only when he drives out on the road, and then the slickest part of the job is intended to be only on the spots that show the most.

Here's something worth while writing us, for the benefit of the cause of good farming. Is there an abandoned or run-out farm in your neighborhood, the history of which you know? If so, why not write and tell us the story of it, giving the causes that led to its deterioration. We should like to print some of these stories in FARM AND FIRESIDE and pay for them, of course, if we print them. They ought to be brief and clear, and point a moral that farmers can find real value in. Another thing: Do you happen to know intimately a case of some man's taking one of those run-out farms and restoring it to productiveness? Do you know how it was done? If so, write us that story. We believe a good many people would find it enlightening. Let your light shine.

Cow-Peas for Ensilage

AT FAIRHOPE, Alabama, this winter the writer saw as fine ensilage as any one could ask for, made exclusively from cow-peas. It was being fed to registered Jerseys whose appreciation of it was evident. The owner asserts that cow-peas are an ideal silage crop in southern Alabama. The crop must be left in the field until the pods are yellow before being placed in the silo. Here on the eastern shore of Mobile Bay is being tried a most interesting experiment in dairying. The cows are tested scientifically and fed by the soiling system. No pasture will be provided for. The barn and buildings are so constructed as to economize labor in every way and the expectation is that a man, his wife and one hand will take care of twenty cows, feed them, cultivate the crops and haul out the manure every day. The South is deficient in pasture; but if the system entered upon on this farm can be shown to be commercially profitable, there would seem to be a great future for the dairyman in the South, in spite of the lack of blue-grass and timothy.



The FARMERS' LOBBY.

By Judson C. Welliver

Investigation of High Cost of Living by Friends of High Tariff . . . Conversation Manual for Congressional Candidates . . . Solicitude About the Consumer's Nickels and Negligence About His Dollars . . . Where Some of the Latter Go . . . How You and I Pay for Water in Stock.

IF YOU were circumstanced so that day by day you could watch the interesting performance which is being staged by the Senate Committee to investigate the high cost of living, you would by this time have got a pretty accurate impression of the parliamentary procedure which is technically known as a "whitewash." A whitewash is an investigation that does not investigate, an inquiry that is careful not to inquire, ending with a verdict of "not guilty" based on the presentation of only part of the facts.

This present investigation, however, is intended to accomplish more than the usual formal verdict of not guilty. It is designed to bring forth and lay before the public a mass of testimony from which a certain kind of argument may be developed—argument in support of the Aldrich-Payne tariff law.

That law is going to be the largest issue in the congressional campaign the coming autumn, and it is of the utmost importance to the high-tariff interests that the material be gathered together, from which the most artful and effective defense may be made of the new law. In effect, therefore, this investigation has taken a commission to prepare a handbook, a campaign manual, out of which may be adduced "arguments" and "facts" in support of the Aldrich law.

I don't say this complainingly; certainly not with any purpose to criticize unduly the party in power. I know that the Democrats, when they have been in power, have done very similar things many a time. That is part of the game of politics, and probably it is inseparable from popular government. There isn't any doubt that you can fool some of the people all of the time, and almost all of them some of the time, and it is a regrettable fact that the forces nowadays in control of politics—politics in both parties—include a large proportion of leaders who conceive that their highest successes in statecraft are accomplished when they most effectively bunco the largest possible number of folk for the longest possible period.

* * *

BUT you will want to know how it is being done in this investigation. Bear in mind that the chairman and dominating spirit in the investigation is Senator Henry Cabot Lodge, of Massachusetts. He is the same shrewd statesman who, when this tariff bill was reported a year ago, sent word to the textile manufacturers of New England, through the Boston newspapers, in substance thus:

"The cotton and woolen schedules are such a good thing that I really don't dare to talk much about them."

Well, Senators Dolliver and LaFollette sat up o' nights and studied those schedules, and told the country about the concealed jokers which warmed the cockles of the Lodge heart and made Lodge anxious that no undue attention should be attracted to those schedules. Mr. Lodge wanted the public to know as little as possible about the beauties of those schedules in which his New England friends were interested, lest too much knowledge might be dangerous to the graft.

Mind, then, this is the same gentleman who is now directing the "broad, impartial and searching" investigation that is to prove—that the tariff is all right!

The committee started out to look into the retailer. Retail dealers, particularly in groceries, meats, fish, game, butter and eggs, milk and the like, were summoned from many cities to tell about the conditions of their trade, the prices they pay and those they receive, the tastes of the buying public, etc. Early in this branch of the inquiry a groceryman from Baltimore was examined. He told about the immense increase of prices of necessities of life, said half the retailers in Baltimore were earning a bare living and on the verge of bankruptcy and that most of them would be glad to retire if they could only find buyers for their business. And then he went on:

"The five-cent shows are ruining business in those parts of the city where the working people live. The people spend their money on the moving-picture shows, instead of paying their bills."

Whereupon the five-cent show business received a rigorous inquisition, and the fact of the public's reckless extravagance in attending these shows was brought out in all its hideousness!

You might think that at this stage of the investigation some thought would have been given to the steadily mounting railroad rates which have been the rule of the last ten years, taking money by millions and adding the rate taxation to the burden which the

consumer must pay in his price. But no; the hundreds of millions of increase in transportation tolls has not been deemed worthy of consideration as yet. The committee has been too busy getting at the horrendous truth about the wild extravagance of the workingman's family which goes to a five-cent theater!

* * *

AND along about the same time that this inquisition into the villainies of the five-cent show was going on, Senator Lodge made a speech in a New Jersey town. The investigation by his committee was the theme of his remarks. The senator pointed out the difficulty of proving the real causes of high prices. That the tariff cannot have anything much to do with it, he undertook to illustrate by showing that the price of raw cotton, which is not protected and is not controlled by a trust, has been steadily advancing for years; the price of sugar, which is highly protected and controlled by a trust, has been steadily going down and the price of oil, controlled by a trust, but not protected, has been likewise going down.

The senator was in error in describing oil as unprotected, for under the Dingley law it was highly protected by a countervailing duty, despite that it was nominally on the free list. But that is a fair sample of the reasoning and the facts used by the proponents of the extreme high-tariff program.

It is hardly necessary to answer the Lodge statement. Raw cotton has been rising in price because the world's supply has not been keeping pace with the demand, and also because of the increasing volume of money everywhere, which tends to raise all prices. Sugar has fluctuated somewhat in recent years; but the small reductions in price may be traced directly to the reduction of tariff duties under the reciprocity agreement with Cuba and under the free-trade arrangement which lets in a vast tonnage of sugar from our colonies free of duty. Sugar, in short, far from proving that neither the tariff nor the trusts make high prices, is the perfect proof that the tariff and some of the trusts are most intimately related. Kerosene? Yes, kerosene is cheaper than it was forty years ago; a good deal cheaper. But it is costing the consumer about fifty per cent more than it would cost him if the Standard Oil Company were willing, or were forced, to take only a reasonable profit on its actual investment.

* * *

BUT when I set out in this letter I had in mind to tell about the greatest of the causes of high prices, the particular cause that the Lodge committee is not bothering to investigate, and will not hereafter worry about. That is inflation of capitalization.

If you have a hardware-store worth ten thousand dollars and incorporate it, you would naturally incorporate it for ten thousand dollars capital. That would be honest valuation of what you have.

But suppose when you incorporate you decide to increase the capital to one hundred thousand dollars. That doesn't mean that you have added anything to the stock or made the business more valuable. You have simply marked it up because it pleased your vanity to have a one-hundred-thousand-dollar, instead of a ten-thousand-dollar, corporation.

You sell your one hundred thousand dollars of stock to various people who were innocent enough to believe that a one-hundred-thousand-dollar corporation must have one hundred thousand dollars of property. These innocents finally discover they paid too much. They must either lose their money or else make the business earn more. How can they make it earn more—enough more to pay dividends on ten times as much capital as it ought to have?

By no possible process except increasing the prices of what it sells. That is perfectly plain. But you can't do that with your hardware-store, because there is another store across the street that is still struggling

along with a primitive, honest capitalization. The man running it will not raise his prices with you, and if he declines to raise, you can't.

That is why overcapitalization is no grave menace where the competitive field is open and everybody has a chance. But turn to a railroad, which is naturally and inevitably a monopoly; to the street-car lines in a city; to the gas and electric plants; the waterworks; the telephone exchanges; the heating and lighting systems. These things, nowadays, are beyond the pale of potential competition. In some cases competition is physically impossible; in all it is economically undesirable and extravagant; in most, it has been effectively ended by actual control of all possible competitors.

So, competition being eliminated as the guarantee of reasonable prices, the financial manipulator is free to increase his capitalization and then to make it earn dividends by boosting the price of what he sells—gas or gypsum or sausage or street-car tickets or steam railroad transportation or copper or telegraph messages. The public is compelled to patronize; and when the price is based on the requirement that the business shall earn dividends on five times the actual investment, why—the cost of living goes up.

I have before me a copy of Moody's Manual of Corporation Securities for 1909. There are over three thousand one hundred pages of the fine-print text, in which it very briefly describes the great business concerns of the country. There are so many of them that you will find plenty of ten-million-dollar corporations dismissed with ten lines or less of space. Now, I have been something of a student of considerable classes of these great concerns of the progress of railroad capitalization, consolidation and reorganization, of several of the great trusts. And I venture to say that among these thousands of huge corporations, with billions of property and tens of billions of capitalization, not ten per cent of those dealt in on 'change are honestly capitalized. They are inflated to the limit.

* * *

JAMES J. HILL bought something over one hundred million dollars of stock of the Chicago, Burlington and Quincy Railroad, and straightway issued bonds to the amount of two dollars for every dollar of the stock. That is, he doubled the face of the capitalization. Who pays the interest on that added one hundred million dollars of capital?

Manifestly, the people who use the railroad.

Has the railroad been earning these increased dividends?

It certainly has, and a surplus besides.

Have rates on the Burlington system gone up or down, during this period?

They have gone steadily upward as to freights, producing many millions of additional revenue. As to passenger rates, there have been slight reductions, but the increased business induced by lower rates has increased the revenues and profits from this traffic, too.

There is the case of one railroad system's inflation. You, Mr. Farmer, pay for that inflation, so does the man whose extravagance in attending the five-cent theater gave shivers to Senator Lodge's committee. So does everybody who uses a railroad or consumes anything that gets shipped over a railroad.

The Steel Trust took about four hundred million dollars worth of property, capitalized it at one billion four hundred million dollars and has made the public pay prices which have earned returns on that billion of fiat capital.

Everybody knows about these things in a general way. I might cite hundreds of cases; I might tabulate the figures to show how many billion of dollars of fiat wealth has been manufactured by this process. But it is unnecessary.

What I want to get at is that the Lodge committee on cost of living is not worrying itself at all about these matters. It is too busy studying the social and economic effects of the five-cent moving-picture show!

It is going to find, when it gets done, that the people are too extravagant. I woen it will worry itself before it is very far along about the farmers' automobiles and discover that the farmers' wild excesses are really responsible for the fact that we folk in town are hard up all the time.

But it isn't going to discover anything discreditable to a tariff-protected trust or a water-logged railroad combination or an inflated industrial corporation. That isn't what it is there for.

The Mysterious Envelope

Or the Missing One Hundred Thousand Dollars

A Two-Part Story by Charles Edmonds Walk

Illustrated by R. Emmett Owen

Chapter V. (Continued)

"WHERE'S it at?" he demanded.

"Never mind. Before making any disclosures, I want to know what you mean to do."

"Well, all I see that's to be done is to get you two up to headquarters and let the old man take a turn at," he jerked a stubby thumb toward Truesdell, "him."

"That's just what you are not going to do," said Miss Brandon decisively, adding

with a significance that impressed the detective, "if you want to catch your man and recover the money. To succeed in both means ten thousand dollars, don't forget."

Mr. Sharp's demeanor showed very plainly that he had not forgotten. Still, it was also quite clear that he was in something of a dilemma. At last:

"What would you advise, lady?" he inquired.

Her manner was direct and businesslike.

"This," replied she, "call a taxi, and the three of us will go to Mr. Beckley. I venture to say that the entire mystery will there be cleared within thirty minutes. But, whatever you do, don't let Fisher escape."

"Fisher!" ejaculated Mr. Sharp.

"Yes, Fisher—Hartwell Fisher. When I get my hands upon a certain envelope, I believe I can show you just how he disposed of the money. He did it under the very noses of you officers, too."

Mr. Sharp indulged in a long breath. It was manifest that the girl was a little too much for him.

"Well," he said with some reluctance, "I sure ain't wise to what you've got up your sleeve; but I don't see any harm in going first to Mr. Beckley, seeing that he wants to keep things quiet. I'll just punch this button and have the waiter call a cab."

While waiting, Truesdell naturally could not restrain his curiosity; but when Miss Brandon importuned him not to say a word and to abide in patience the outcome of her coup, he fell silent and contented himself with glowering at the thick-set man from Central.

He had to submit, too, when the girl insisted on paying his breakfast check. "I have a reason," she whispered to him, smiling into his eyes. "You had your way once this morning; pray let me have mine now."

"How did you find us?" she asked Mr. Sharp.

"Easiest thing in the world," replied that worthy. "A detail of men made a round of the banks this morning to see if any thousand-dollar bills had turned up. I went into the Drover's National just as this party," another jerk of the stubby thumb indicated Truesdell, "left. The teller pointed him out. Didn't pinch him then because I thought he didn't have all that bundle in his clothes. I trailed him here; but when you blew in I nearly backed off the platform. I just run in on the siding and piped your patter."

Miss Brandon blushed furiously.

"You heard all of it?" she cried aghast.

"No'm; only after youse two got to scrappin'."

Miss Brandon sighed with relief. And the arriving taxicab put a period to the colloquy.

Chapter VI.

MR. ELM BECKLEY, New York manager of the Seaboard Express Company, was a nervous, abrupt man, weighted down with the multitudinous responsibilities attaching to his position. When the party of three were ushered into his private office in the third story of the Seaboard's building, he jerked his desk-chair around and scowled at the daring intruders, until he observed that one of them was Miss Kitty Brandon. Then a smile transformed his oppugnant expression to one of marked pleasure.

"Mr. Beckley," impetuously began the girl, "I've recovered the money."

He shot from his chair as if tossed by a powerful spring.

"What!" he roared. "You!" Then he sank limply back again and uttered a fervent, "Thank God!" But in a moment he pulled himself together sufficiently to go on:

"So that's where you've been all morning, is it? I had to use Ashton's stenographer—the dunce!—and the mess my letters are in—" He groaned and brought down his fist upon the pile of correspondence on his desk. But the greater worry all at once predominated and he inquired eagerly:

"Where is it? Lord have mercy! but the suspense

and anxiety of the past two days have aged me twenty years."

The girl gave him a sympathetic look and spoke gently.

"This gentleman has it," she smiled at Truesdell; "give it to me, Scott."

His hand went unhesitatingly after the envelope; but before he could produce it, Mr. James Sharp, with round, staring eyes, rose slowly to an upright position and ejaculated:

"Him? All that dough on him and him chasin' 'round the streets, like he's been all morning?" His look became one of admiring awe. "Say, young fellow, let's see it, will you?" he asked in a voice husky with emotion. "I never see such a roll as that in all my life."

But as Miss Brandon took the fat envelope, she bent a glance upon the big man that made him drop into his chair again, where, rather abashed, he remained watching the various speakers with uncomprehending eyes. Mr. Sharp was fitted for coping only with the obvious and he was not at ease until he began to understand.

"Truesdell, Truesdell," repeated Mr. Beckley after the young man had been presented. "Miss Brandon, isn't that the name of the old duffer that you were hobnobbing with yesterday?"

She darted an embarrassed glance at Truesdell.

"He was this Mr. Truesdell's uncle," she explained.

"I addressed this envelope for him yesterday. Here is the money intact."

"No," Truesdell added, handing the manager the one thousand dollars in smaller bills. "This makes the even one hundred thousand." He wondered hazily how Kitty had divined the deplorable state of his finances, and was overwhelmed with confusion when two copper pennies fell from the roll of notes and jingled upon the floor before the assembled group.



"Trembling with rage, he cried hoarsely, 'I can't stand this; I'll tell you all about it'"

"But how the devil does he come to have—" Mr. Beckley began; but the girl calmly broke in.

"I'll try to make it clear; I think I can." She turned to Truesdell. "Scott, I'm Mr. Beckley's private stenographer—"

"A mighty good one, too," that gentleman vigorously interpolated, with a despairing glance at the heap of letters on his desk. But the girl went on evenly, as if accustomed to these untimely interruptions.

"Yesterday afternoon I had occasion to go downstairs to the local offices on the first floor and who should I run plump into but your Uncle Seth. Of course, I was overjoyed to see him—not especially because he is your uncle; I know there was never any love lost between you—but he was somebody from Colton, and I haven't seen a soul from there in all the years I have been in New York."

"Well, it seemed that you had left him—were some place in town—and that he had sold out everything and was on his way to South Dakota. He wanted to send you one hundred dollars and, as he lacked a definite address, the company refused to assume the responsibility of delivery."

"To make a long story short, he was in a hurry to catch his train and he finally made up his mind to leave the money with me. I was to write to you, care of general delivery and, when I heard from you, send you the money."

"I typed a brief note, and then addressed the same envelope he had the money in—a hundred-dollar bill it was. It was late in the evening before I got to it and Hartwell Fisher was in the room, waiting to take the last batch of mail to the post-office."

Miss Brandon's manner all at once grew more serious. She faced the manager, saying:

"Now, Mr. Beckley, I want you to send for Hart-

well Fisher; I want him to hear the rest of my story." She turned quickly to Sharp.

"You," she said crisply, "keep an eye on him; no telling what may happen before I get through."

"Ps-s-st! Trust me, lady," Mr. Sharp confidently assured her. "That duck's like a man with the willies right now; he's sure slated for a fall and I have a hunch that it's you yourself that's going to start him down the toboggan. Watch us."

In a moment a tall, pale young man, with a nervous manner and shifty eyes, entered the room. When he saw the company he recoiled, as if intending a precipitate retreat. But in a flash Sharp was between him and the door. He roughly pushed the man toward a chair.

"Forget it," said he. "Here's where you get yours, sport; stay and take it like a little man."

Chapter VII.

FISHER staggered to the chair, his face ashy, his dry tongue feverishly caressing his lips. Miss Brandon could not repress a smile at the confidence she was beginning to inspire in the husky detective.

"Day before yesterday," she pursued, "a certain bank, which I need not specify, consigned with the Seaboard a large shipment of currency for delivery to one of its up-state correspondents. It was one hundred thousand dollars, all in new one-thousand-dollar notes."

"The money went through the regular channels—or, at least, the slips of the various clerks who handled it showed that it had; but it failed to arrive at its destination yesterday morning, as it should have."

"The matter was kept quiet and a prompt investigation soon narrowed suspicion to three men: Hartwell Fisher, a clerk

in the out-money department; John Griggs, city messenger, and the express messenger on the train.

"Mr. Fisher was late that night; it was eight o'clock before he had some twenty odd packages of money ready for Mr. Griggs, and the latter was growing impatient. He knew he had only a short time within which to make the Grand Central, and he was naturally in a hurry to get off."

"Fisher knew this and he took advantage of it. Delaying his work as long as possible, he finally handed Griggs the various packages—all except the biggest consignment—and Griggs signed the slip without taking time to verify it—just what Fisher counted on. He barely made the train, and the train messenger did the same thing, a bit of negligence which I dare say neither will ever be guilty of again."

"Why, it was the easiest thing in the world to do. Fisher simply held out the package, destroyed the company envelope and hid the notes somewhere in his office. He could take his time to it, for he was alone after Griggs left."

"When the three suspects were put through the third degree, the police had no lever

with which to force a confession. A search of every likely place where the money might be hid brought nothing to light and late yesterday afternoon the hunt drifted to the out-money office.

"In anticipation of this Fisher took the bills from their hiding-place and put them into his pocket. As Mr. Beckley left for home, he directed Fisher to wait and get the mail before going to supper, and while Fisher waited for me to address the last three or four envelopes, Mr. Sharp and his colleagues were searching the out-money office."

"I noticed that Fisher was nervous and fidgety, but attributed it to his impatience to be off, since he had to return after supper."

"All at once I saw him pick up a long envelope and scribble something on it, and when I offered to address it for him on the machine, he thrust it into his pocket and told me gruffly to never mind."

"If you are in such a desperate hurry," I said to Mr. Fisher, 'you might inclose and stamp the letters.'

"He commenced doing so immediately; there were thirty or forty altogether, and with these in his hand he started for the door. Just then the door opened, and Mr. Sharp appeared and called him into the out-money office."

She paused and again turned to Sharp, who was darkly eyeing the crushed Fisher.

"Tell me just what happened then, please," she requested.

"Why," began he, "we thought we had the duck dead to rights; the bills just couldn't be anywhere else but in his clothes. 'No post-office to-night,' I says when he pokes the bundle of letters at me. 'I'll just drop 'em down the mail-chute in the hall while me friends Clancy and Donigan go over you with a fine-tooth comb.'"

[CONCLUDED ON PAGE 34]

With the Editor

WHEN I was a boy in central Iowa, we used to have just two guesses as to the identity of the man seen scooting across the prairies in a top-buggy—or, as we always called it, a "covered carriage."

The first guess was that it was the sheriff—and we watched the equipage as far as we could so as to know what unfortunate farmer was sued for his store-bill or on a note for machinery or was having notice of the foreclosure of a mortgage served upon him.

If the first guess was wrong, the second was almost sure to be right—it was the doctor. And we could reckon with a good deal of accuracy how many visits from the doctor would cause one from the sheriff. Nobody but the doctor and the sheriff could afford a top-buggy—and they had to have them!

Wheat was our great crop. From the time when the shocks were off the stubble-field until the earth froze, it was my job to plow for the next year's sowing. And when the year's work was done, and the grain hauled to market and sold for from fifty cents to seventy cents a bushel, there was mighty little in the way of reward. As for corn, we sometimes burned that for fuel. It was contended by some of the neighbors that it was wicked to burn corn, but my father was unable to see why he should haul the corn fourteen miles to market and get so little for it that the coal it bought had less heat in it than the corn.

It was a time of debt and deprivation. There were few Sunday suits, few pleasure carriages of any sort, few books, few papers, few comfortable houses, few bank accounts and few of what the political economists call the "luxuries and conveniences of life."

FARM AND FIRESIDE'S GREAT OFFER TO READERS

To introduce Farm and Fireside to your neighbors who are not now subscribers, the editors make you this unparalleled offer:

Get two people each to give you 25 cents for an 8-month trial subscription to Farm and Fireside. Send us the 50 cents, and in return for the favor we will send you Farm and Fireside for 8 months without cost after your present subscription expires. (If you are not now a subscriber, your own subscription will be entered for 8 months without cost.) In addition, the editors will send you a Beautiful Gift, with their compliments. This offer is good for one month only, until May 10th.

You will find a subscription blank on Page 2.

FARM AND FIRESIDE Springfield, Ohio

Very few farmers' beds were anything but box-like affairs with posts at the corners and a rope cord to hold the bedding up. Many large families lived in houses with but two or three rooms—and lived not altogether unhappy and quite self-respecting lives. And the clothes we wore—men, women, girls and boys—would make fine pictures of us for the Sunday papers if they could be reproduced as evidences of poverty.

And all this time, we were producing the grain and the produce generally that crushed the Eastern farmer to the very earth. And not only the Eastern farmer, but the European farmer, too. The more we raised, the more we broke the market, both for ourselves and for the older states. We had nothing to do but work, and we established new records of the capacity of a man to till the soil. It was originally supposed that five men were required to keep up with a Buckeye dropper or a McCormick or Champion reaper "binding stations"—but the pressure of need forced the boys of the middle West to run from sheaf to sheaf, with the blood almost bursting from their temples with the heat, that each might bind a third of what a team would cut, in spite of heat waves and brash straw. It was in the middle West that the farmer began the plowing of the row of corn on both sides at once, of tying two harrows together at the corners and sweeping forty acres a day like a young tornado, of running gangs of plows, of husking a hundred bushels of corn a day, of driving a seeder and leading a team with a drag. The old adage ran to the effect that a man to get rich must live like a hermit and work like a horse. The mid-Western farmer in those days lived like a beggar and worked like a fiend. And the more fiendishly he expended his life in producing wheat and corn and beef and hogs, the lower the market went.

If times are a little better for him now, isn't he entitled to the change?

According to Bradstreet's editor, bread-stuffs are a hundred per cent higher now than on July 1, 1896, and I have been referring to a time much earlier than that—a time of even lower prices. Live stock is one hundred and sixteen per cent higher. Provisions have gone up seventy-three per cent—and we produce

most of the provisions. Fruits are forty per cent higher, leather fifty-five per cent, wheat a hundred per cent, corn one hundred and six per cent, potatoes one hundred per cent, eggs two hundred and sixteen per cent, milk sixty-six per cent, cotton one hundred and thirteen per cent, wool one hundred and eighteen per cent, live beeves seventy-two per cent live sheep fifty per cent, live hogs one hundred and fifty-two per cent, (this comparison was worked out before the recent sensational rise in hogs). That the things the farmer sells are higher than in 1896, by from fifty to one hundred per cent, must be quite true. It isn't all clear gain, for while the living expenses of the rest of the world have gone up, the farmer's have risen with them. But while living expenses have increased, the margin above them has done so, too, and it is with this margin that he pays debts.

And what do debt-free farms mean to the farmers of East, West, North and South?

They mean that for the first time in half a century it looks as if they would be able to live freely and breathe easily, consuming the fruits of their own labor. It means a different standard of living. It should mean more time devoted to clubs and institutes, and the study on the part of both men and women of the things that make people modern and up-to-date. It means modern houses and less typhoid, scarlet fever and diphtheria. It means—or it should mean—a better kind of rural schools, in which the pride of occupation that makes all workers successful shall be instilled into the farm children: they are about the last to receive it. It means a new life based on

farm conditions and not slavishly modeled on city life.

Farmers will have pleasanter rooms in which to live, and more and better furniture in them. There will be more buying of automobiles by farmers. They will not buy them until they are able to, if they are wise; but those able to support them will have them, and will run them more cheaply and efficiently than will most city men—for the farmer is always more or less of a mechanic. There will be many more engines and windmills and water-wheels doing work on the farm in the future than in the past. The farming population, to a great extent

emancipated from debt, will become the heaviest buyers of "the elegancies and conveniences" of life in all the country.

What does all this signify? It signifies that the farmer will no longer go without the things which progress has brought to the race. For fifty years he has seen others reap where he has sown, he has seen other men eat bread in the sweat of his brow. Will he continue to do so? He is still mostly blind to the benefits of farmers' organizations, and of coöperative marketing; will he continue to be so? No, the broader view is coming, and with it will come still better conditions.

The farmer is not responsible for the high cost of living. This has resulted from the scarcity of farmers and their products, rather than from any control over prices possessed by farmers. That control they have not now, nor did they ever have it. But along with the high cost of living—which has been felt by farmers as by others—have come conditions which promise better times for the farmer who owns his land than we have ever seen in the memory of man. And if there is anything in justice, the farmers are entitled to the good time coming, no matter how good it may be. The low prices from which the Bradstreet's editor counts these rises in prices meant industrial slavery for the farmers. If they are now higher, they ought to be. Why do they stay up? Merely because the rewards of farm life have not been sufficient to tempt into the business men enough to glut the market. The nation as a whole will be better off, even with high cost of living, if it is never again glutted.

Robert S. Linn



YOU can do it-yourself—that's the secret of the wonderful success of Jap-a-lac. With a can of Jap-a-lac and a brush, you can make your porch chairs look like new and have them any color you wish; Jap-a-lac comes in seventeen beautiful colors, and natural or clear. Look at your chairs today, don't they need refinishing? Why not do it yourself? There are articles about every home that the housewife can

RENEW WITH JAP-A-LAC

REG. U. S. PAT. OFF.

Jap-a-lac can be used on everything of wood or metal from cellar to garret.

The Jap-a-lac Model Floor Graining Process solves the problem of "What shall I do with my old carpeted floor to make it sanitary and refined?" Your painter can do it at a little expense or you can do it yourself. Insist on Jap-a-lac. For sale by Paint, Hardware and Drug Stores.



"THE JAP CHAP"

Write for illustrated booklet containing interesting information and beautiful color card. Free on request. If your dealer does not keep Jap-a-lac, send us 10c to cover cost of mailing, and we will send a free sample, quarter-pint can of any color (except gold which is 25c) to any point in the United States.

Our Green Label line of clear varnishes is the highest quality manufactured. Its use insures perfect results. Ask your paint dealer.

The Glidden Varnish Company

5420 Glidden Bldg., Cleveland, O.

The quality of Jap-a-lac has no substitute. It has never been equalled.

10 DAYS FREE TRIAL We will ship you a "RANGER" BICYCLE on approval, freight prepaid to any place in the United States without a cent deposit in advance, and allow ten days free trial from the day you receive it. If it does not suit you in every way and is not all or more than we claim for it and a better bicycle than you can get anywhere else regardless of price, or if for any reason whatever you do not wish to keep it, ship it back to us at our expense for freight and you will not be out one cent.

LOW FACTORY PRICES We sell the highest grade bicycles direct from factory to rider at lower prices than any other house. We save you \$10 to \$25 middlemen's profit on every bicycle. Highest grade models with Puncture-Proof tires, Imported Roller chains, pedals, etc., at prices no higher than cheap mail order bicycles; also reliable medium grade models at unheard of low prices.

RIDER AGENTS WANTED In each town and district to ride and exhibit a sample 1910 "Ranger" Bicycle furnished by us. You will be astonished at the wonderfully low prices and the liberal propositions and special offer we will give on the first 1910 sample going to your town. Write at once for our special offer.

DO NOT BUY a bicycle or a pair of tires from anyone at any price until you receive our catalogue and learn our low prices and liberal terms. **BICYCLE DEALERS**, you can sell our bicycles under your own name plate at double our prices. Orders filled the day received.

SECOND HAND BICYCLES—limited number taken in trade by our Chicago retail stores will be closed out at once, at \$3 to \$8 each. Descriptive bargain list mailed free.

TIRES, COASTER BRAKE rear wheels, inner tubes, lamps, cyclometers, parts, repairs and everything in the bicycle line at half usual prices, and containing a great fund of interesting matter and useful information. It only costs a postal to get everything. Write it now.

MEAD CYCLE CO. Dept. B-83, CHICAGO, ILL.

The Four and a Half Million "Bell" Telephones in This Country Are Western-Electric Telephones

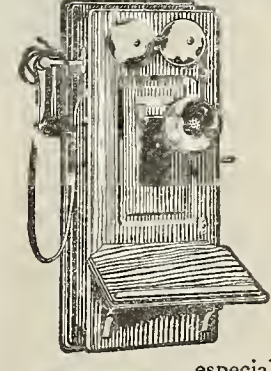

The telephones that carry messages from New York to Chicago, from Boston to Washington—that transact the business of the large cities—all are Western-Electric telephones. Knowing this fact, would you, or anyone, buy any other instruments than

Western-Electric Rural Telephones

especially when they cost no more than inferior makes. In all respects they are the same as the "Bell" Telephones. Reliable instruments that you can depend upon are even more important for rural service than city service. You know the reliability of Western Electric Telephones—the world's standard telephones. What do you actually know about others? Don't let yours be the instrument to fail at some critical time in your local service.

All you need do is to fill out the attached coupon and mail it to our nearest house listed below and we will mail you free this book. It explains how you and your neighbors can get all material and build your lines in a few days.

WESTERN ELECTRIC COMPANY

Write Our Nearest House

New York,	Chicago,	Saint Louis,	San Francisco,
Philadelphia,	Indianapolis,	Kansas City,	Los Angeles,
Boston,	Cincinnati,	Denver,	Seattle,
Pittsburg,	Minneapolis,	Dallas,	Salt Lake City,
Atlanta,	Winnipeg,	Omaha,	Berlin,
Montreal,	Vancouver,	Antwerp,	Paris.

Your name and address written in this space will bring complete information

Booklet No. 50

Name Address

Keeping the Boy on the Farm

By Eugene Wood, Author of "Back Home," Etc.

"How to keep the Boys on the Farm." That's a good subject. Easy, too. A simple proposition in algebra.

Let x equal eight o'clock of a rainy winter evening at a house on the left-hand side of the road that turns off at the Bolinger place as you go toward East Liberty. You know where the Bolinger place is. It's about six miles from New Caledonia, and about four miles from Milford Station. This house that x equals is two miles, or maybe two and a half, from where you turn off. You can't miss it, because it's the first one you come to, and there's only one other between the New Caledonia pike and the river road. And that is on the other side of the road. I didn't choose it because only old man Huffaker and his wife live there. This house that x equals has a son in it besides the farmer and his wife. The son is about twenty years old. You must get it very clearly in your mind that this house is where it is, and that it holds a farmer and his wife, and their only child, a son about twenty years old, that it is eight o'clock of a winter evening, that it is thawing weather and that it has been raining steadily for two days. You'll want to think what



"When he can kind o' take a-holt . . . why he up and leaves me"

the roads would be like, but you mustn't. You must just remember that this is x .

Let y equal eight o'clock of the same rainy winter evening somewhere around Broadway and 42d Street, somewhere in that section where the air is thick with the smell of gasoline and tremulous with automobiles, out of which step men in fur-lined overcoats and evening clothes, and young women whose cheeks (when you get an eighth or quarter side view) have the color and curve of a ripe peach. Whether they have the same firmness and flavor is something that you can tell only by biting. And we haven't time for that now. The women's bared shoulders are protected by fluffy wraps of such delicate texture and hue, salmon or pink or pale blue or pale green or lilac or lemon, that you might imagine that the late clouds of a summer sunset had been spun into threads of gossamer, woven into fabrics, formed into garments, and trimmed with lace made out of sea-foam.

Maybe it is the opera they are going to, the opera where the loveliest voices in all the world will flutter presently, as it were butterflies snared in an air-drawn net of harmony whose meshes are the throbbing tones of the violins, the rich full tones of clarinets, the silvery tones of flutes, the slender acid tones of oboes and English horns, and the solemn trombones—all the multifarious tone-colors of the modern orchestra knotted together to snare these lovely voices. Or maybe it is only a foolish play that they are going to, a foolish play so funny that the muscles of your stomach will ache because you have to laugh so much.

Out on the road to East Liberty a rainy night is gloomy and dispiriting, but on a rainy night Broadway and 42d Street never looks so splendid, for the wet sidewalks and asphalt pavement seem like a sea of glass mingled with fire, as the mirroring surface gives back the splendor of those globes of light that either rival the full moon or the sun itself as it yellows toward its setting; as it reflects the brilliance of all the advertising signs whose letters are written in golden electric lamps, framed in green electric lamps, and around the frames serpents of red electric lamps chase each other tirelessly. It will be no trouble to you at all to remember that this is y .

Now all you've got to do is to make x equal y . When you've done that, then the problem of "How to Keep the Boys on the Farm" is solved.

I said it was an easy one. So it is, if you look at it that way.

When I was ciphering my way through Ray's Third Part Arithmetic, after I had got the answer to the

example about how many men it would take in so many days and a half to mow a meadow so long and so wide, provided each man mowed so much in a day, I could begin on the next example of how many bricks it would take to build a wall so long and so high and so thick the bricks being of such and such dimensions. The two problems had no living thing to do with each other except as they were all worked by the same set of rules. But when you cipher your way through the arithmetic of life you find that every problem in it is intimately and indissolubly connected with every other problem in the past, in the present and in the future. So that you cannot help respecting those who attempt to give you a short and succinct solution of "How to Keep the Boy on the Farm." Such courage merits respect.

I have thought about the matter many times, and if I were to write down the whole thing properly for FARM AND FIRESIDE, it would take up so much space that there wouldn't be any room left for good advice as to when is the proper time to spray the turnip-trees. Just to show you how much more complicated the problem is than perhaps you have any notion of, let me say that gold-mining, and practising law, and the price of currency, and retail stores, and the price of meat, and reaping machines, and the Constitution of the United States, and wives taking their husbands' names, and war, and slavery—in fact, every event in the whole history of the human race up to now, and what will be in the future, is sewed up in the problem of "How to Keep the Boy on the Farm," not with chain-stitch, but with lock-stitch that cannot be ripped out. I can't go into the whole history of the human race, past, present and to come. The editor won't stand for it. Not a minute!

And what makes the problem still more ticklish is its moral aspect. Suppose I am the farmer who lives in that house out on the road to East Liberty, and the young fellow twenty years old is my son. He's a fine, strong, hearty fellow. A good boy, too, if I do say so myself. He's had a very careful bringing up, and his mother and I have looked after him the best we knew how. He has no bad habits. He's a little headstrong sometimes, and has the conceit that he knows more than his daddy, especially when I don't give in to tom-fool notions about farming that he picks up the land knows where, these "professors' ideas"—I understand how young fellows are. I was once a young fellow myself. But what gets me is that he wants to leave the farm and his mother and—me, and try his luck in the city. That looks downright wicked.

Between you and me, it's ungrateful. That's what it is! After all I've done for him, fed him and clothed him when he was only an expense to me, and sent him to school when it was so that I could



"Eight o'clock somewhere around Broadway and 42d Street"

spare him from work, and now just when he's getting so that he's some account to me, when he can kind o' take a-holt and let me lay back and take things easy, telling him what to do and seeing that he does it right, why, he up and leaves me. And I've got to hire a man to take his place. I don't need to tell you how do-less and trifling a hired man is, how lazy and good-for-nothing, how little interest he has in his work, how prone to give back-talk, how he can hog down victuals and how grasping he is about wages, never satisfied with what he is getting. I don't need to tell you about all that. You know. And for my own son to do me this way—It's worse than foolish; it's downright wicked.

This matter of the boys leaving the farm is a

moral problem. Distinctly so. And when you consider moral problems you step right off into deep water where it's 'way over your head. Moral laws, as well as civil laws, are enforced by certain people and sets of people, and they compel obedience to different precepts, some of which are undoubtedly for the good of humanity as a whole, and some of them are for the good of the people or the class of people that do the enforcing. It isn't always as easy as rolling off a log to determine which precept is for which class' benefit. I guess I'd better not consider the moral aspect of "How to Keep the Boy on the Farm."

I can easily put myself into the position of the farmer in the house on the East Liberty road this rainy evening. I can just as easily—I don't know but more so—put myself into the position of the would-be wandering boy who is thinking of packing his



"Why—er—why—er, x isn't so bad after all"

grip and starting out to see what kind of dirt there is at the far end of the big road. Looking at it from his viewpoint, if x is that house on the East Liberty road, and y is Broadway and 42d Street, and it is eight o'clock on a rainy evening, why, there is no sort of question in my mind that y is about four million times as great as x . But I'm only "putting" myself in the boy's place. It's *me* all the time that's there. And y also carries with it the supposition that one of the gentlemen in the fur-lined overcoats, handing out a young woman with a cheek like a ripe peach from an automobile, is the gifted author of the lines you now peruse.

But—here's a good place to pay strict attention—if the gifted author of the lines you now peruse hasn't the dollar and a half in his pocket with which to buy a seat in the back of the topmost gallery of all, some eight flights up from the street-level and walk every step of it; if he has, instead, fifteen cents in his pocket with which to hire a bed for the night in a lodging-house which he will share with six-legged gentry that do not pay for their lodging; if it is a rainy night, and no umbrella, and there are shoes that need half-soling, and it is a long walk down to the Bowery, why—er—why—er, x isn't so bad after all.

And you don't have to be so hard up as all that either to find y the little end of the horn. Fifteen dollars a week to spend in the house on the road to East Liberty is simple affluence; fifteen dollars a week to spend at Broadway and 42d Street is wretchedness unspeakable. It isn't enough to starve to death on—that is, decently. And even if you have more than that, if you have twenty-five dollars a week—yes, if you have fifty dollars a week, you cannot be as all-around comfortable as in the house on the road to East Liberty. You can get more luxuries, you can have more fun and more excitement, but, in the last analysis, the human animal subsists largely upon food; it requires air to breathe; it must have sleep. And I say to you that quiet, undisturbed sleep in New York City is something you cannot buy for fifty dollars a week, nor can you get sweet, pure air for that as a regular thing, and it comes pretty near to there being no such thing as food for that—that is, if you are one of those fussed creatures who like to feel reasonably safe about opening a boiled egg. As for chicken or sausages in the city—well, I hope I have learned some sense by this time.

To be sure, a young man of twenty born and brought up on the farm has so much vitality that he can stand 'most anything for quite a while. He'll pay for it after he is forty, but that's twenty years away. Never mind about that. By that time he will be so much

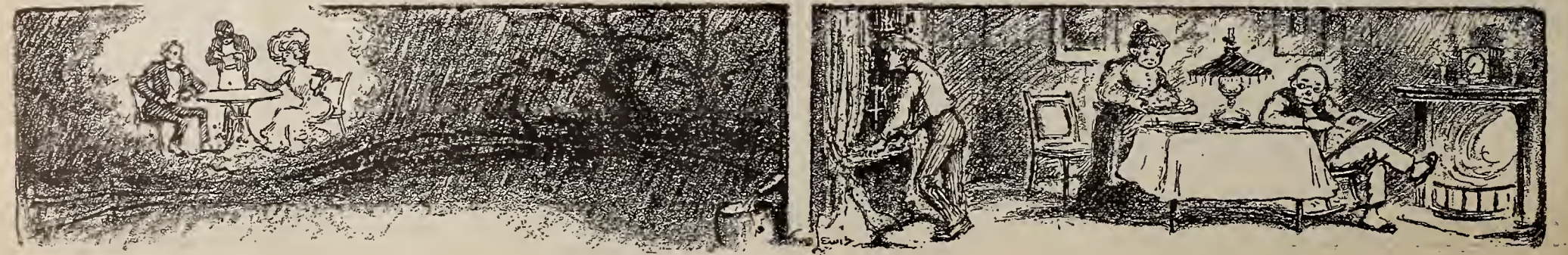

better off than he would be if he stayed on a farm that he can make up for it. Why, look at all the multi-millionaires who in the early period of their lives had to bawl: "Who-haw, Nellie! Git ep, Bill!" Look at all the plain millionaires. They say that those who have only a million dollars are the unhappiest of men. I don't know this for a positive fact. I've only heard say so. One of 'em told a particular friend of mine and he told me. It comes to me pretty straight, but I intend to try it and find out for myself if it's so. I'll tell you later. And not only the multi-millionaires and the plain millionaires, but the ever-increasing host of those whose income is five thousand dollars a year and upward. Besides these there is the still larger host, still more rapidly increasing, of those who haven't made out so very well, but who keep on hoping, and keep on hoping and will keep on hoping till they get buried. They generally stop hoping about that time. If you want to make money, you've got to go where money is. And there is money in the city. Oodles of it. Oodles and oodles of it. And more on top of that. Only, you mustn't forget that the rich city is composed of poor people, so poor that one in every ten has to be buried in a pauper's grave. You know a person has to be pretty poor for that, friendless and alone, with nobody that can or will pay for the funeral. And there's one in every ten in New York City in just that fix. That, in my estimation, kind o' throws additional light on the algebraic proposition of whether y is much greater than x, take it as a general thing. One in every ten is pretty thick, you know, and you don't really begin to get so that you have much comfort out of life in New York City short of five thousand dollars a year. You can rub along on less, but it's rubbing along.

* * *

It all depends upon what kind of a boy that young fellow is in the house on the road that turns off past the Bolinger place. Roughly speaking there are two kinds of men in the world, the makers and the marketers. Every sort of man or occupation falls into the classification, either plainly and obviously or indirectly and obscurely, but certainly nevertheless.

You, young fellow in the house on the lonely road, let me ask you a few questions as to your qualifications for launching out. Have you ever done any horse-trading? You have, eh? How did you make out? Pretty well, eh? Well, I tell you: "If you can get the best of the bargain nine times out of ten, if you can swop off some old, spavined, knee-sprung rack of bones that ought to be looking out for the sign that reads: "This Way to the Glue-Factory;" and get in exchange a fine, first-class animal, with boot of a shot-gun (you may need that in your business) and a watch that will go part of the time, long enough to sell it, anyway, you've no call to stay on the farm. You are needed in the city in financial circles. I predict for you a career of unexampled prosperity. Don't hesitate. Don't underrate yourself. It is easier to swing a transaction amounting to two hundred million dollars than a transaction amounting to two hundred dollars, if you have a horse-trading record such as I have outlined.

If you are a good salesman, don't stay on the farm. Prices are going up all the time, much faster than the income wherewith to pay the prices. Consequently it takes more and more skill to induce a purchaser to buy what he cannot really afford. Anybody can make commodities. Machinery is constantly being perfected toward the point where neither strength nor skill is required to make things, where not even judgment is required, only an automatic stupidity that can make two or, at most, three motions all day long, year in, year out. But when it comes to marketing the commodities, that's a different matter. You must be smart to do that. And you must be smarter and smarter every year. And your reward becomes greater. Be-

cause the commodities have simply GOT to be sold or there's no sense in producing them. The money isn't in the manufacturing; it's all in the marketing.

But if you are handy with tools, if you delight in making things, if it is a pleasure for you to devise the best and the quickest way to accomplish a job, if you have a disposition that leads you to inquire into the nature of living things, I kind of think the farm's the best place for you. Certainly the city will scald your heart out. You may think you'd like to try railroading. What's that poetry about the joys of railroading? "Gits to Peru every night and sees the show." You'll probably have a chance to hire out to some railroad or other before long. The wages are so poor and the work is so hard that the men will strike for conditions a shade less inhuman, and you can offer yourself and help prevent other men from getting a living wage. It's a healthful occupation. You're out of doors a good deal of the time, and it isn't very much more dangerous than going into battle. Quite a number of railroad men die natural deaths.

You may be "fond of machinery" and think you'd like to learn the machinist's trade. There isn't any. There are no more trades to learn. Learning a trade is oush-ker-shpeel. They do everything by machinery nowadays. You may think you'd like to become a mechanical or chemical engineer. You can hire some mighty good men in those walks of industry for twenty dollars a week. A man that would marry on twenty dollars a week these days ought to be shot as a sanitary precaution for the good of the community.

If you have in you the Instinct of Workmanship, that instinct is just as well satisfied to express itself in one direction as another, provided it can express itself adequately. I tell you that all other industries than agriculture have got about as far as they can go now without agriculture. That has stuck pretty much where it was in 1850. All the others have gone away ahead of it and have called to them the nimblest and most ingenious minds. With the result that they have gone ahead of the power to feed themselves. That's why the cost of living goes up by leaps and bounds, and will go on leaping and bounding until it gets to the point where farming will be as remunerative as any other employment.

My own notion is (and it is distinctly my own notion: FARM AND FIRESIDE is not in the least responsible for it) that the factory method will have to be applied to raising crops. Those who get this idea into their heads first, and are right there with the goods, will make a few dollars. They will make enough to enable them to get around and see things, and have a good time, and enjoy life.

And I won't say that there won't be a place for those who can drive a sharp bargain. Only, the agricultural class must take a leaf out of the book of the other industrialists. They long ago got out of the way of each proprietor of a dinky little factory, or buying what they need in competition with all the others in their line. They sell collectively, and they buy collectively. The farmer is at the wrong end of the bargain, in selling and in buying. But if the farmers all together hired a few sharp bargainers to sell their product collectively and buy their supplies collectively—why, say, do you know how much a dollar's worth of work of the farmer is worth when it comes to buying a dollar's worth of work of other productive workers? About seventeen cents. If this arrangement can be made, I don't know that Broadway and 42d Street would have much of anything on the house on the East Liberty road. I don't know but what x would measure up with y pretty well.

Yes, sir, if I were that young fellow twenty years old in that farm-house this rainy evening, I'd— Maybe I wouldn't, though. Maybe I'd be just such another one.

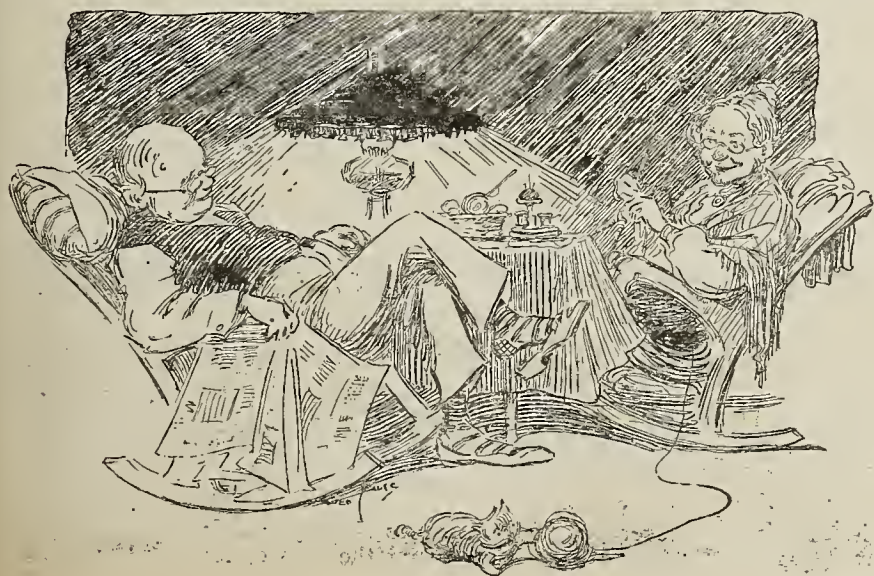

Haste and Waste

Stop and think for a moment the next time you are about to buy soda crackers.

Instead of hastily buying soda crackers that go to waste because broken, soiled or soggy, buy

Uneeda Biscuit

in separate five-cent packages. Soda crackers in large packages soon become broken, stale and unpalatable. On the other hand, Uneeda Biscuit in handy, moisture proof packages are *always* fresh, clean, crisp and whole—not one wasted.

(Never Sold in Bulk)

NATIONAL BISCUIT COMPANY

Surprise Package of 50 Beautiful Post-Cards

EVERY lover of beautiful post-cards will want this collection of 50 cards. Every card is printed in 12 colors. The set contains the choicest assortment of delightful cards—birthstone cards, showing the precious stone and the flower appropri-

Fifty Surprises

We do not show pictures of any of these beautiful cards because that would spoil your surprise. Every card will be a surprise—50 surprises in all.

ate to people born in each of the 12 months; friendship cards, each one picturing a beautiful flower and an appropriate verse. Besides these, there are many more beautiful and artistic post-cards. This set of 50 cards comprises the most popular and beautiful post-cards of sentiment ever brought together.

How to Get the Cards

We will send you the Surprise Package of 50 beautiful Post-cards without cost by return mail if you will send two 8-month trial subscriptions to Farm and Fireside at 25c each. One may be your own. Don't fail to get them.

Use that Coupon

FARM AND FIRESIDE
Springfield, Ohio

FARM
AND
FIRESIDE
Springfield, O.

Send me your
Surprise Pack-
age of 50 Post-
cards, and send
Farm and Fireside
for 8 months to the
names below for which
I inclose 50 cents.
Yours truly,

Sender

Send This Coupon

Old Man Potter

By Winifred Kirkland

Illustrated by Anna W. Speakman



THE sawmill hangs wedged in the ravine where Crow Brook comes leaping out from the brown pine-wood. Above the door, straggling home-made letters announce, "G. Potter and Son." The pines of the slope press close to the weather-stained slab walls of the mill, and from its window slits and door you can look off up into the brown shadows and hear the crows calling among the windy pine-tops. There on the slopes, when the changing years brought the springtime, Ella always

found the first arbutus bloom.

Now, in late June, the dusk of the pines was broken by spots of pink laurel. Below the mill, its side wall facing it, stood the house, trim and white, even to the filigree cornice of the side porch on which the kitchen opened. The grass was fine-clipped, unlike most farm-house grass-plots. To the front two flower-beds showed stunted, sulky bush and stalk as if their days of vigor and bloom were long over. The fence-paling was freshly whitewashed, but within, a row of sweet peas clung in sickly fashion, not yet sprung more than a foot above the soil. Over the clean freshness of the turf were scattered here and there bones half gnawed and the feathers and feet of a chicken recently plucked. A few feet from the porch the grass ceased, leaving a space of raw soil, oozy with soapuds and sprinkled coffee-grounds, into which some young chickens were poking hungry bills. About one pillar of the porch some one had once planted a Virginia creeper, but the stalk stood now raw and dead, cut off short by some impatient hand. Flies swarmed into the kitchen through the screen door left half open and buzzed about the breakfast-table in the sultry air. The breakfast was set at one end of the table on the bare board; at the other side the stained table-cloth was turned back over last night's supper-dishes, still unwashed.

It was one of Mate's black days. The two men, seated to right and left of her, ate furtively, ashamed of their appetites. Yet Old Man Potter was hungry, having been busy at the mill since five o'clock, while his son Walt was sleeping, and Mate was lying moodily watching the sunshine on the dingy pane and letting the breakfast-hour creep later and later. The hand that lifted the saucer of black coffee to his lips trembled a little with weariness and the heat, hale as Old Man Potter was at seventy-five.

Across from his father, Walt ate with one elbow resting on the table. His pale brown eyes watched Mate stealthily, his weak, good-natured mouth ever ready to frame itself into a smile to cheer her.

Between them, at the end of the table, Mate, Walt's wife, ate in silence, now and then fishing a fly from her coffee-cup with her spoon and dashing it savagely on the rag carpet of the kitchen floor. A shapeless Mother Hubbard wrapper did not conceal the flowing lines of her opulent young figure. She was a large woman, her work-reddened hands large and shapely, her arms, bare to the shoulder, white and firm. The wrapper, unbuttoned at the neck, showed a throat beautifully molded. Her hair, ash-colored, dusted with gold, was piled high in an uncombed mass. Her blue eyes beneath lowered lids were cloudy and sullen, her mouth moody. In spite of all, the rich grace of her youth triumphed over her slovenliness and her evil mood.

Beside his two children, Old Man Potter, in his healthy, clean-scrubbed, pink-and-white old age, was a figure out of place in that grimy kitchen. His shirt, though collarless, was always glistening white. His overalls, the blue bib of which was held in place by straps across his shoulders, were spotless. In spite of rough work, even his finger-nails were clean, for Ella, his dead wife, had loved daintiness.

Old Man Potter was quietly philosophic. True, he loved to see the children happy, was himself merry as a small boy on the days when Mate's mood was as inexplicably gay as it was to-day dark and depressing, but when Mate was unhappy he tried to forget her. It was not hard this morning, for his keen old brain was busy trying to find a means to unravel the mistake Walt had made in the letter to Griggs and Company, a mistake that might cost them a cool two hundred. His father wondered mildly, as he and Ella had often wondered, where Walt got his incapacity. Not from himself; in all modesty he could hardly think that, and certainly not from his mother. What was it that had made Walt so different from Rosie, their other child? Old Man Potter's gaze

passed over Walt's head to the window, where once morning-glories had laughed against a pane diamond bright, in the days when the house was Ella's. His thoughts were far away as he gulped down his coffee. Mate had put sugar in it, which he abhorred, something she always did on dark days.

A furry ball of a Maltese kitten pushed its way in through the screen door and came to nestle against Old Man Potter's ankle. He took a crumb of sausage from his plate and stopped to feed the little friendly purring thing, but Mate snatched the kitten up.

"Don't you know no better than to feed her meat, father!" she rebuked him sharply, as she fondled the gray mite fiercely against her bare throat.

The old man's blue eyes rested upon them, thoughtful and far away. When he saw the tenderness in Mate's caressing fingers, he wished, as he had so often done, that she had a child to nestle that way on her breast. Women were different when there were babies, and when there were none men should be very patient. A smile came to his old lips. "She grows fast, don't she?" he said, his eyes upon Mate's kitten.

Mate shrugged her shoulders angrily, as if the mere sound of his voice irritated her, and he realized that he had better keep quiet that morning. Mate now poured her coffee-cup full of milk and let the kitten lap it, whereupon Walt teasingly soused the little head in the cup, so that the poor kit came up sneezing and sputtering. Walt roared with laughter and Mate smiled upon him indulgently. The old man reflected an instant upon her certain ferocity if he had touched her kitten, and then again half smiled, remembering how Mate loved Walt. He often wondered why Mate's love did not make Walt more of a man, for Old Man Potter himself was one who had walked reverently all his days because of a woman's faith in him. He still went on doing every day what Ella wanted, and the south chamber, where she had died, was still kept by his own hands clean as a shrine.

Mate at length put the kitten down and pushed it from her, sullenness again settling on her lips. Some chance words of Walt's to his father brought down the storm.

"Father, do you want I should drive over to Jeph Pierce's this morning and see about hauling them pine-logs. If you think so I'll go over right away."



"It was one of Mate's black days"

"No—" began his father, but was interrupted by Mate, who turned upon Walt somewhat angrily.

"Walt, ain't you partner in the mill, even if your father don't allow you but a fourth part? Why don't you go for the logs if you want to, without asking, 'May I?' as if you weren't but six years old? 'Tain't your fault, I know, that you ain't more independent, but ain't you never goin' to be growed up and have your own say-so, I want to know?"

From lowered lashes Walt regarded his father deprecatingly, his question still unanswered.

"No—" the old man began again, in mild explanation, but again Mate's rush of words.

"No, and 'no,' and 'no.' I notice it's always 'no' when Walt wants to do anything about the business, big or little. It's 'no' when Walt wants to get Pierce's logs and 'no' when he wants his half of the partnership. But the trouble is there's some folks wants it all."

Old Man Potter's lips turned a little pinched, although he had heard this before when Mate was in a tantrum. Again he began, "We ain't got no room for Pierce's logs until—"

"Oh, 'room,' no room for Pierce's logs and no room for Walt; that's about what it is. Ain't you never goin' to let Walt have his chance? Haven't young folks got no rights? There'd be room enough for

Walt if you'd get out and let him have it. Don't you know when you're old and have had enough? Room enough—" her voice was shrill; as usual, she had lashed herself to a frenzy. "I tell you, there's some folks whose room is better than their company."

"Shut up, Mate!" cried Walt, for wholly unexpectedly to himself, a tear had suddenly splashed down on Old Man Potter's nose. He brushed it aside, got up unsteadily and hurried out down the porch toward the mill. Mechanically he kicked aside a bone from the little path he tried to keep neat. Through misty eyes he saw the stunted sweet peas and wondered why he could not make flowers grow as Ella had made them grow. The kitten came bounding over the grass in the sunshine. He picked it up and pressed its furry head to his wistful lips. He entered the clean-swept room of the mill, into which the sun slanted through the open door in a bar of dancing notes. Through the window he could look up into the cool pine-wood. He started an instant, for it seemed as if up there on the shadowy slope he saw Ella's sunbonneted form stooped to pluck a blossom from the ferny mold; but it was only a mass of laurel. The air was resinous with fresh sawdust, and in the silence of the buzzing saw the gurgle of the brook beneath the floor was loud and monotonous. He sat down on a pile of fresh-sawed boards, the frisking kitten on his knee.

He sat there a long time, stroking the kitten, and thinking and wondering. Once he heard a sound of scraping and the rattle of wheels as the buggy was brought out from the barn shed. Several times he tried to rouse himself to set the gear in order and start the saw, but each time an unaccustomed weariness held him fast; he would wait till Walt came to help. All the time the old man wondered, wondered. Sometimes there flashed across his brain a vision of Rosie's home, clean as Ella's and always ruddy-warm with welcome. Then suddenly he was startled.

"Say, father!" It was Walt in the doorway, peering in, a hand on each lintel post. Walt dressed in Sunday brown, a white straw hat pushed back on his curly hair.

"Say, do you mind, father, I thought I'd drive Mate over to Kenton. Maybe it'll cheer her up a bit, and we'll have dinner at the hotel. Do you reckon you can spare me to-day? Shall I stop and send Ed Smith up to help this afternoon?"

"He charges a good bit," the old man hesitated, "but I reckon you'd better send him."

"You don't mind us going off?"

"No." And at last he raised his tired eyes, and far off and very keen they studied all Walt's face self-excusing, fatuous, helpless, affectionate—the old eyes saw it all, saw what a woman may love. Presently the beat of hoofs died away in the distance, and Old Man Potter was all alone. He did not go down to the house. In these later years the mill had become more homelike than Ella's house, with the trail of the slattern over it all and the din of a shrewish voice in the old happy rooms. At last a little smile came to his eyes and mouth, a smile quietly humorous. He shook himself, stretched out his legs, spoke out loud, "Well, ma, do you reckon I'm giving out? Kind of late to go back on you now ain't it, ma?"

Ears dulled by the clatter of the brook, he had not heard a step until he was startled by a woman's voice, a rich ringing voice.

"Hello there, pa!"

Radiant, trembling, he jumped to greet her. It was Rosie, his other child, unexpected, as always, still hot and panting from her walk from the station. Her stout, middle-aged form filled the sunny doorway.

"Couldn't find nobody down to the house, couldn't find nothing there but dirt! Dearie me, I'd rather set down on one of your boards up here than on any of them chairs! Land of Goshen, pa, that woman! And when I think of mother and what you've been used to!" The easy tears rolled down her rosy cheeks, and she mopped them away with a large cotton handkerchief gaily bordered. She breathed heavily, not being used to the tight black dress she thought proper for travel. Her hands in black mitts showed the stunted nails caused by rough work. Her hat was bright with cheap roses. Her black hair fell in straight wisps at her temples and over her collar. This was Rosie, and the hearty health of her, the warmth and sweetness and love of her, wrapped the tired old man around in a rich motherliness like Ella's.

Rosie sat down on the pile of boards beside him, patting his hand rhythmically with her large firm one, as if her father had been one of the baby boys at home. Her shining happy eyes held his.

"Pa," she said, "you can't guess why I've come." His eyes dimmed and shifted from her gaze, for he could guess why she had come; the cup of temptation was held close to Old Man Potter's lips that morning.

"I've come to take you home!" she said, and his breath caught at the stab of longing her words caused

[CONCLUDED ON PAGE 34]



THE HOUSEWIFE'S CLUB



EDITOR'S NOTE—Most every woman has originated some sort of a device or convenience to make part of her housework easier and less burdensome, and to all who have, we would ask that you write and tell us about it. Aside from making a little pin-money for yourself, you will be helping others, and this is what "The Housewife's Club" is for. We will give \$2.00 for the best description and rough sketch of an original home-made household convenience or labor-saving device, and \$1.00 for the next best, or any that can be used. We will also give 25 cents each for good kitchen hints and suggestions, also good tested recipes that can be used. All copy must be in Contributions must be written in ink, on one side of the paper, and must contain not more than 250 words. We would suggest that contributors retain copies of their manuscripts as no contribution will be returned. Address "The Housewife's Club," care of Farm and Fireside, Springfield, Ohio.

by the tenth of May.

An Original Sewing-Basket

A VERY convenient sewing-basket may be made from a cheese-box. The top, or cover, is used for the lower shelf and broomsticks for the legs, which should be two feet long. Bore holes near the edge of the cover and insert the sticks. With brass tacks nail them to the sides of the cover. The lower shelf is then finished. The box should be screwed through the bottom and the ends of the sticks. Now give the completed affair a coat of paint in any color desired and then enamel it. I lined the box with cretonne and put pockets in it to hold needles, thread, thimbles, buttons, scissors, etc. This sewing-basket is convenient for holding the week's mending.

Mrs. W. R. L., Texas.

Old-Fashioned Light Pone

SIFT together one quart of white corn-meal, one cupful of wheat-flour, one teaspoonful of salt. Rub in cold one teaspoonful of lard or butter. Add two tablespoonfuls of sugar and one well-beaten egg and one half cupful of good yeast. It must be beaten smooth with the least possible amount of slightly warm water. The process of mixing is the most important. Use a strong spoon, because, unless it is mixed stiff, the pone will be a failure. Set it in a warm place until it becomes light—about three to five hours is long enough, provided you use good yeast, and that it is kept warm, but not hot. When the surface cracks, it is light. When it is light, stir in one fourth of a teaspoonful of bread soda dissolved in one fourth of a cupful of cold water and turn into round baking-pans. Have a batter of flour and milk (or water) and spread over thinly. Bake in a moderate oven. Serve hot.

Mrs. A. F. T., Pennsylvania.

For Pie-Makers

WHEN making berry-pies, put the sugar in the bottom of the crust, instead of on top of the berries. This prevents the juice from spilling over and in no way affects the flavor of the pie.

Always make your pie-crust with cold water—ice-water, if possible. It will make the crust crisp and flakey.

Keep all fruit-juice and bits of fruit left over from dessert and pie making. Put it in a jar, add a little vinegar and then strain. This makes good, strong vinegar.

Mrs. M. J. B., Oregon.

Useful Kitchen Desk

I FIND this home-made kitchen desk invaluable and I think every housekeeper needs one. The desk was put up by

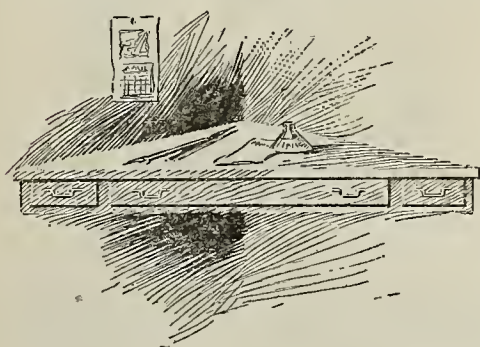

my husband. It is made of a box fitted into one corner of the kitchen and is supported by two iron brackets. It contains three drawers—two small ones for money, stamps, etc., and a large one for my record books, memorandum books in which I keep my kitchen accounts. On top I have a tray for my pens and pencils, blotters and ink, and hanging on the wall just above the desk is a small calendar. Whenever I want to write or refer to the cook-book, I know just where to go.

Mrs. C. S. N., New Hampshire.

Coloring for Candies

SAVE the juice from beets; add to each pint of juice one pint of sugar and let boil until it thickens. Then put it into a bottle for future use. This is excellent for coloring ices, cakes and candy.

A. V. S., Missouri.

Hints Worth Knowing

Hot alum-water is the best insect-destroyer that I know of. Put the alum into hot water and let it boil until it is dissolved. With a brush apply the hot solution to all cracks, closets, bedsteads and other places. Mrs. S. E., Kansas.

To prevent a bruise from turning black, apply at once a small piece of laundry starch. Moisten with cold water. Mrs. A. A. M., Massachusetts.

I find that if hot water is used my cake will not be tough. I think it is much more satisfactory than milk.

To make the stove black and glossy rub it over with a cloth dipped in cold coffee. Mrs. H. B. C., Massachusetts.

To remove ink-stains from the fingers, moisten the part with water and rub the spots with the sulphur end of a match.

C. B. N., Colorado.

The juice squeezed out of finely-scraped raw turnips and then warmed is excellent to pour in the ear for an ear-ache.

Suffering caused from a burn can be relieved by wrapping the part with a cloth saturated with witch-hazel.

Mrs. D. C., Missouri.

Improvised Steamer

IT OFTEN happens that when one wants to steam a pudding or some other dish that the regular steamer is in use.

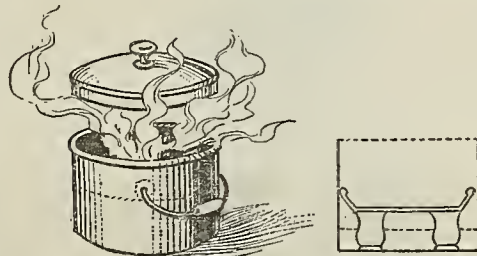

And so it is very helpful to know how to improvise an extra steamer from a few kitchen articles. For instance, take a six-quart pail and put two or three cups in the bottom and fill the pail with hot water half-way to the tops of the cups. On the cups place a tin plate as shown in the illustration. The article which is to be steamed is placed on this plate, the cover put on the pail and your steamer is complete.

Mrs. V. C. D., Pennsylvania.

To Clean Brass

THE simplest and most satisfactory method of cleaning brass of any kind is to dampen a cloth with ammonia, then rub it briskly over a piece of pumice-soap. This mixture applied to the brass acts like magic.

A. V. S., Missouri.

Apple-Puff

BAKE six large apples. While hot take one pint of their pulp, add one cupful of sugar, one half teaspoonful of grated lemon-rind and the juice of half a lemon. Beat the mixture light and add three well-whipped egg-yokes, then the whites beaten to a stiff froth and lastly a pinch of salt. Rub cold pudding-dish with butter, cover with some browned bread-crumbs, add the prepared apple, sprinkle with more crumbs and bake twenty minutes. Serve with sugared cream. Z. I. D., Michigan.

Setting Color in Wash Goods

GREEN and red may be set in garments before laundering them by soaking the goods an hour or two in two gallons of salt-water, into which a lump of alum about the size of a walnut has been dissolved.

Blue can be set by soaking the material in two gallons of soft water, in which a teaspoonful of copperas and a pinch of lime as large as a sparrow's egg have been dissolved. A tablespoonful of turpentine to a gallon of water will also set blue very nicely.

Salt or black pepper in the water will set black.

A garment that has faded may be bleached white by soaking it fifteen minutes in two gallons of soft water into which one pound of chlorid of lime and a spoonful of sal-soda have been dissolved. Rinse thoroughly and dry in the sunshine.

Mrs. H. M. R., Tennessee.

Good Nickel Polish

BUY five cents' worth of whiting, put a teaspoonful in an old dish and mix to a thin paste with a little kerosene. Apply this to the nickel. Let it dry until it looks white and then rub it with a flannel rag. The nickel will glitter like new. The kerosene helps to keep the nickel from rusting or becoming greasy. Five cents' worth keeps my range shiny for a year.

Mrs. A. M., Michigan.

Belt for Iron-Holders

I WAS always dropping or misplacing my iron-holders until I originated this simple device. I made a belt of

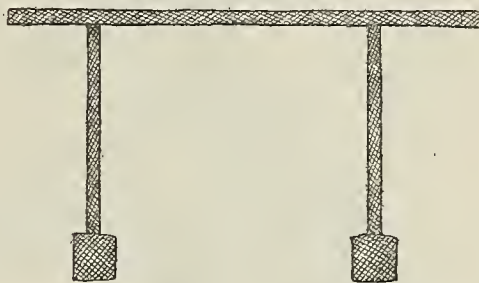

gingham and sewed on it two strips. To them I attached the iron-holders. The belt fastens over my apron, and in this way the holders are always at hand when needed. If desired, the belt may fasten with a button and buttonhole.

A. C. P., Massachusetts.

To Sugar Doughnuts

HERE is a good way to sugar doughnuts. Take a small paper bag, put in it some confectioner's sugar and as the doughnuts are taken from the fat put one in the bag, draw the top together and shake up and down until the doughnut is well covered with sugar. Continue until every one has been sugared. We always like our doughnuts with plenty of sugar and I think this idea for sugaring them is a good one.

B. M. E., Connecticut.

A Mending Hint

I WANT to tell our readers how I darn loosely-woven underwear and stockings. I buy mosquito-netting in the color desired, and as soon as I find a thin place in the stocking I baste a piece of the netting on the under side, darning in and out and carefully following the meshes of the netting.

Mrs. V. S., New York.

Broken Umbrella-Handles

CLEAN the hole in the handle where the rod came out and fill it with powdered sulphur. Heat the rod until it becomes red hot and press it down into the sulphur. Do not handle the umbrella until the rod is cold, and it will be as firm as when new.

A. M. C., Pennsylvania.



Right Finishes for Every Purpose

That's the Acme Quality idea. Whatever you want to paint or finish, indoors or out, about the home or farm, there's an Acme Quality Paint, Enamel, Stain, Varnish or other finish made especially for the purpose.

Acme Quality products have become a household necessity, and the best dealers carry a complete line in stock, have color cards to make selections from, and are thoroughly informed on the proper materials to use for all purposes.

The ACME QUALITY Guide Book

is a standard authority on painting and finishing. It is consulted by professionals and amateurs alike. We will send you a free copy on request.

Acme White Lead and Color Works

Dept. X, Detroit, Mich.



It is to your advantage to mention Farm and Fireside in writing to advertisers. Farm and Fireside folks get the very best attention.

Martha Washington Comfort Shoes

Genuine comfort—that's what it means to wear the stylish Martha Washington Comfort Shoes.

They fit like a glove, and insure complete rest and relief. No buttons or laces—just slip them on and off like a slipper. Elastic at the sides provides perfect fit over any instep. You will never know how comfortable a good looking shoe can be until you have worn

MARTHA WASHINGTON COMFORT SHOES

Beware of imitations. Only the genuine have the name Martha Washington and Mayer Trade Mark stamped on the sole. Refuse substitutes. Your dealer will supply you; if not, write to us.

FREE - If you will send us the name of a dealer who does not handle Martha Washington Comfort Shoes, we will send you free, postpaid, a beautiful picture of Martha Washington, Size 15 x 20.

We also make Honor-Bilt Shoes for men, Leading Lady Shoes, Yerma Cushion Shoes, Special Merit School Shoes and Work Shoes.

F. Mayer Boot & Shoe Co.

MILWAUKEE, WIS.

When You Buy a Piano
 you want to know you are
 getting the best for your money.

CORNISH

Sent To You For A Year's Free Trial

Cornish Pianos for real merit, are unexcelled by any other, whatever the price, or name or reputation



Save One-Third—Buy On The CORNISH PLAN—Easy Terms

Send For The New CORNISH BOOK

The most beautiful piano catalogue issued—it explains things that you ought to know whether you buy from us or elsewhere. The book is yours for the asking. Write for it now.

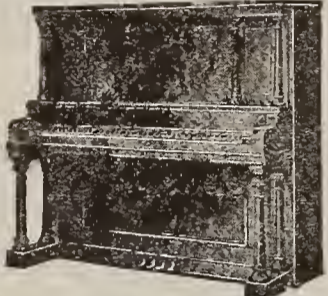

Washington, New Jersey Established Over 50 Years

CORNISH CO

\$2.50 a Month
 BUYS A GENUINE
KIMBALL ORGAN
 AT FACTORY PRICES



FREE Music Instructions by our DIAGRAM SYSTEM and Piano Stool, if you write us at once.

You can now buy the famous Kimball Organs direct from the makers at factory prices. We will send them to reliable people anywhere, to be paid for on our extremely easy payment plan—\$2.50 monthly and upwards, if desired.

Operating the largest organ factory in the world, employing the largest capital, buying raw material in the greatest quantity for cash—the Kimball system of manufacturing and distributing positively saves you \$20 to \$50 on strictly first-class organs.

If you want an organ at all, you want a good one; a mere pretty case with no music in it will not do. Secure at once the old reliable Kimball Organ at Factory Prices and pay on convenient terms, and get Free our New Diagram System of Self-Instruction in Music, with which anyone can learn to play in a short time.

SEND TO-DAY FOR MONEY-SAVING PLAN AND 30 DAYS' FREE TRIAL OFFER

Under no circumstances can you afford to buy or consider any other organ until you have our money-saving proposition.

Our half a century's manufacturing experience; our financially strong guarantee means much to you.

The most inexperienced buyer, a thousand or more miles away, can deal with us as wisely as the shrewdest trader, or as though you were here in person, for your organ will be selected by an expert. A fine stool and music book free with each organ. Write TO-DAY for Free Catalog.

W. W. KIMBALL CO., 355 Kimball Hall, Chicago, Ill.

THEODORE ROOSEVELT'S
 own account of his African trip—now appearing in
SCRIBNER'S MAGAZINE

is the most popular magazine contribution for years and of great interest to a large number of new readers. 100,000 subscription orders already placed—here is a great opportunity for subscription agents. Liberal cash commissions and many extra prizes are offered those who can devote even a little time to soliciting subscriptions. Representatives wanted in every town of America. For particulars address, at once, Desk 10, Scribner's Magazine, 155 Fifth Avenue, New York City.

MEMORIALS & MONUMENTS
 FOR CEMETERIES SCHOOLS & PARKS
 LARGE VARIETY OF DESIGNS FOR EVERY PURPOSE—DELIVERED ANYWHERE—SEND FOR CATALOGS STATE REQUIREMENTS—AGENTS WANTED
MONUMENTAL BRONZE CO.
 347 HOWARD AVE., BRIDGEPORT CONN.

STEM WINDS SET WATCH RING & CHAIN GIVEN
 FOR SELLING POST CARDS
 We positively give a STEM WIND, STEM SET, BEAUTIFULLY ENGRAVED, PLATED WATCH, equal in appearance to Solid Gold Watch, American made, guaranteed and a beautiful Ring set with an Im. Diamond, for selling only 20 pkgs of beautiful high grade art post-cards at 10c a package. Order 20 packages, and when sent send us \$2, and we will positively send you the Watch, Ring and Chain.
 Wells Mfg. Co., Dept. 476 Chicago

Send Your **Old Carpet**
 We Will Make **New Rugs**
 Beautiful designs to your taste—Plain, Fancy, Oriental—fit for any parlor. Guaranteed to wear ten years.
Rugs, 50c and up
 Ours is the largest factory of its kind in America. Established 37 years. Originators of OLSON FLUFF RUG (Grand Prizes at 3 World's Fairs).
We Pay the Freight!
 Old carpets are worth money; don't throw yours away.
FREE Write today for book of designs, prices and complete information.
OLSON RUG CO.
 1044 Madison St, Chicago

Some Practical

Fabrics and Accessories



Two fabrics which stand specially in the foreground this spring are foulard and shantung. The shantungs are most fashionable in natural color with trimmings of black and chantecler, which is scarlet, while the foulards are seen in many colors and designs. They are usually trimmed with folds of plain silk in the same color as the figured fabric of which the dress is made. The gown shown in illustration Nos. 1494 and 1495 would be very smart, indeed, if made of natural-colored shantung, with the sleeves and yoke embroidered in black. The pipings should be made of scarlet silk and the finishing touch a scarlet leather belt.

in Russian colors are used with foulard dresses, as well as the leather belts. It is an odd combination, but a fashionable one.

Leather belts are also worn with shirt-waist dresses made of linen, gingham, cotton rep and madras. A very attractive dress may be developed in any of these serviceable wash fabrics if made like the design shown on opposite page in pattern Nos. 1543 and 1544. It is strictly tailored, the only trimming being machine-stitching and buttons. And buttons are much used for trimming purposes this season. Buttons representing mother-of-pearls, changing from the light to dark tones of a color, are among the newest shown this spring. They were designed specially for such gowns as the shirt-waist dress illustrated on opposite page.

This gown would also be extremely attractive and serviceable, too, made of dark blue foulard in polka-dot design. The lace yoke could be the same shade of blue as the foulard and the pipings of the fashionable red. The red leather belt should also complete this costume. This design can also be used for materials like linen or chambray, with cotton braid for the trimming.

The skirt of this dress is really very modish, for although plain and draped skirts will be much worn, plaited skirts are returning to take their place at the head of tailored fashions. Some of the new skirts show the upper part of the skirt plain, with the portion below the knees plaited regularly or in groups, while other skirts are plaited from the waistline and stitched as far down as the knees. Really the necessary finishing touches of a shirt-waist dress fit in beautifully with the new dress accessories, for the separate belt is accompanied by the stiff tailored collar, with a tie of black satin or matching the belt with which it is worn.

With the return of the two-piece gown comes the vogue for the separate belt, and it has never been more popular than this season. The black patent leather and the black suede belts are much worn and so are very gay little belts of leather in such shades as red and apple-green. Linen belts rather coarsely embroidered



No. 1545—Kimono With Inverted Plaits at Back

Pattern cut for 32, 36 and 40 inch bust measures—small, medium and large. Quantity of material required for medium size, or 36 inch bust, ten yards of twenty-two-inch material, or seven yards of thirty-six-inch material, with one and seven eighths yards of contrasting material for trimming-bands



No. 1495—Nine-Gored Skirt With Plaited Insets

Pattern cut for 22, 24, 26 and 28 inch waist measures. Length of skirt all around, 42 inches. Quantity of material required for medium size, or 26 inch waist, six and three fourths yards of thirty-six-inch material, or four and three fourths yards of forty-four-inch material



No. 1494—Tucked Waist With Yoke

Pattern cut for 32, 34, 36 and 38 inch bust measures. Quantity of material required for medium size, or 36 inch bust, two yards of thirty-six-inch material, or one and three eighths yards of forty-four-inch material, with one and one fourth yards of contrasting material for the buttoned-over yoke and deep pointed cuffs



No. 1477—Long-Waisted Dress in Panel Effect

Pattern cut in 4, 6, 8 and 10 year sizes. Quantity of material required for medium size, or 6 years, three and five eighths yards of twenty-four-inch material, or two and one half yards of thirty-six-inch material, with three eighths of a yard of tucking for yoke and wristbands

MADISON SQUARE PATTERNS

FOR every design illustrated on this page, we will furnish a pattern for ten cents. Here is our latest liberal offer in regard to Madison Square patterns. We will give one Madison Square pattern for only two yearly subscriptions to FARM AND FIRESIDE at regular price of fifty cents each. Your own subscription may be one of the two. This offer holds good up to May 1st. We will send FARM AND FIRESIDE one year, new or renewal, and only one pattern for fifty-five cents. Send orders to the Pattern Department, FARM AND FIRESIDE, 11 East 24th Street, New York City. When ordering, be sure to comply with the following directions: For ladies' waists, give bust measure in inches; for skirts, give waist measure in inches; for misses and children, give age. Be sure to mention the number of the pattern you desire. Satisfaction guaranteed. A distinctive feature of the Madison Square patterns is the originality of their designs—up to the moment in style, but never extreme.



How Reporter Rabbit Succeeded

By Alice Jean Cleator

DE CITY Editor Rabbit, ob de "Rabbitville News," he turn from de telephone an' say to Reporter Rabbit, "Git outen to Squirreltown on de double quick! Big fire ober dare. Doan' yo' lef dem 'Foxtown Gazette' fellers git ahaid o' yo'! Does yo' un' stand?"

Now de rabbit fellér he ain't been on de staff ob dat paper mo'n free, fo' weeks. He putty young in de writin' sperience; but he shets he teefs tight an' hushles he note-book inter he pocket an' kotch de berry fust car gwine in de direction ob Squirreltown.

Wal, when dat car gits to its determination at a leetle lake, de rabbit hab to git a boat to cross de lake where dey runs a car fo' Squirreltown. Now who kims dashin' down to de boat landin' wif a ker-ridge an' two yaller mules but Reporter Fox, ob de "Foxtown Gazette." He's gwinter git a boat too.

De rabbit he hushles an' gits one ob de wolf boat-boys to take him ovah in a row-boat. Dey gits started fore de fox. Now when de fox sees de rabbit gittin' de start he sudden fixes 'pon an idee. He hires de wolf boat-house keepah to call dat boat in.

"Hi, dar" calles de boat-house keepah to de boy what's takin' de rabbit across de lake. "Come back wif dat boat. Doan' yo' know bettah'n to take Mistah Rabbit outen a leaky boat?" So de boy rows back. Howsomever de rabbit he know dat a fake story 'bout de boat bein' leaky, but he say when he see de fox feller steppin' he foots inter anudder boat, "I reckon yo' kin take two passengers jis 's well as one in dis yere boat, kint yo'?"

"Landy, but I'se powerful sorry," say de boathouse keepah, winkin' at de fox an' jingling de silber what de fox done paid him, "De fac' o' de mattah am, Mistah Rabbit, hit shore ain' safe to take mo'n one passenger in dis yere boat what I'se jis hired to Mistah Fox. All de odders am outen de lake er in scanlous need o' repair. Dat sholy am too bad, Mistah Rabbit, I 'clare to my soul I hates to dis'p'int such a perlite, respectable gemmelman as yo' 'pears to be!"

Wal, de rabbit he ain' 'ply nuffin back, but he gibs dat boat-house keepah sech a p'digious look ob scorn dat make him feel small's a free-cent piece trimmed offen at de aidges.

De fox he see de rabbit stannin', not knowin' what to do, an' he waves he note-book at de rabbit an' holler from de boat, "Ha Ha! Why doan' yo' swim crost?"

Now dat de berry las' straw to de rabbit, caze he mighty sens'tive 'bout not bein' able to swim like de res' o' de animal fellers; but he doan' spen' no time bein' sassy.

He hushles 'long de bank, feelin' powerful dis-

tressed, not knowin' what to do. Den he say to hisself, "I jis won't gib up, dat I won't. Scouragement an' de blues ain't de stuff what a reporter feller am made of. I'll git dat scoop, I will dat," he say, "Lef me see, I'll g'long furdur up de sho.' Mebbe I'll see suthin' to help me out."

Bimeby he do see suthin'! What yo' think? Tuz a bear! De rabbit he so tirrible skeered he fotch es a jump uppen de air, like a grarshopper.

De bear he a fishin' fo' trout an' pickerel. He ain' want to be disturbed, so he mighty short like when de rabbit gits breff to say, "Howdy, Fren' Bear? Kin yo' help a feller outen a peck o' trouble?"

"Ump!" 'plys de bear, not turnin' he head, "G'long wif yo'. Ain' yo' see I'se fishin'?"

De rabbit he see de bear ain' in no kind o' mood to do a favor, but he thinks he try onst mo'. Den a plan 'curs to him. He knows de bear an' de fox ain' no great fren's, count o' some trouble dey granddaddys



"'Howdy, Fren' Bear? Kin yo' help a feller outen a peck o' trouble?"

had in de pas'. So de rabbit tells de bear all 'bout de scanlous mean trick dat fox feller played on him.

Now de bear all 'tention when he hears anything 'bout a fox. He commence fotchin' he line in an' say, "Dis am a almighty fine fishin' day; de air am de berry breff o' heaben here 'mid de willers an' de cedahs; de win's in de wes', an' dis am a place where fishin' means cotchin'. But," say de bear, "I'll gib it all up, I will dat, to help yo' git ahaid o' dat rascal fox. Come erlong! I'se got a nappity launch down by de alders. Yo' see dem red barns an' dat w'ite house crost de lake? Dat am my farm prop'ty. I'll git yo' ober dare in one, two minutes. Den I'll take yo' to dat fire in my auto. De fox'll hab to wait harf an hour cross de lake fer dat car to Squirreltown. Huh! Huh! I'll git yo' to dat fire long 'fore he's set he foots on de groun's, doan' yo' borry no trouble 'bout dat," say de bear.

Purt' soon de bear an' de rabbit am pop-pop-poppin' crost de lake in de nappity launch. De bear say, "Mebbe yo'd like to heah what de trouble my granddaddy had wif dat fox's granddaddy once 'pon a time. Tuz like dis: One day my granddaddy workin' in de woods layin' open some 'lasses bar'ls what's been lef in a deserted lumbah camp. He get putty hetted up, so he throws he big fur obercoat crost a stump neah-by. Who comes erlong unknownt to him but dat fox's granddaddy, an' cuts offen de tail ob dat fur obercoat. Dat why de bears ain' got no tails! I tell yo' dat reporter fox takes after he granddaddy fur's meanness goes, he sho' do," say de bear.

Wal, in no time de bear, de rabbit an' de driver am choo-choo-in' ober de smooove roads in ter Squirreltown. "I tell yo' de two-minute hoss ain' in it wif dis yere auto," say de bear. "I spec' dat fox am still yit outen that leetle driftin' thing-a-ma-jig ob a row boat!"

When dey gits to de fire, de rabbit hushles he pencil mighty fas' an' gits a fine scoop on dat "Foxtown Gazette." De bear purt' nigh busses heself a-laffin' on de way back thinkin' how's de fox feller'd git leff.

Nex' mawnin' de rabbit newsboys am outen on de streets a-callin', "Rabbitville News! Rabbitville News! All 'bout de big fire at Squirreltown!"

Reporter Rabbit he gits he salary raised 'fore long. De city editor pats him on de back an' say, "Yo'll do putty well, yo' will fer a beginnin' chap! I kin see in yo' de makin' ob a beeg editor man one o' dese days!"

De fox he purt' nigh los' he place on de "Foxtown Gazette." He feel mighty sore 'bout de mattah, an' eber sence den he's been tryin' to git ahaid o' de rabbit feller. He ain't done it yit, an' in my pinionation o' de mattah he nebber, nebber will!

The Letter-Box

DEAR COUSIN SALLY:—"Ohayo! Ohayo!" I enjoyed your letter about the Japanese so much and wish you had written a whole page about Japan, for I love to hear about other countries and other people. Mama was also interested in reading your letter. She saw and talked with several Japanese at the World's Fair, but of course she could not understand what they said. Please write more about other lands. A new member of the C. S. C. EVERETT BLACKMAN, Age Nine, Milan, Missouri.

DEAR COUSIN SALLY:—I have been interested in our corner for a long time. I would like to be one of your cousins and one of your club members, too. I am sending five cents in stamps for one of the club buttons. I know I shall love it.

My schoolmates and I have organized a branch club and call it the Help-One-Another Club—for short, we say the Hoac. None of the members is over fourteen. With love to you and the other cousins,

Your interested cousin,
IRMA MARTHA FIFE,
R. F. D., No. 5, Box 35, Cadiz, Ohio.

DEAR COUSIN SALLY:—I have been a constant reader of FARM AND FIRESIDE for several years and I feel as though I could scarcely get along without it. I am so interested in our own page. I do enjoy reading your letters. I wish you would write and tell us more about the great city in which you live. I live away out here in the mountains of Arkansas, and they are so pretty. I think it is great sport to climb them in the springtime. Love to you and all the cousins.

Your Arkansas cousin,
ROSA REDDINE, Mena, Arkansas.

Honor Roll

Ruth M. Melvin, Chicago, Illinois; Ruth Lee, Montevallo, Alabama; Donna Lannon, South Vienna, Ohio; Leland Baird, Edgmere, New Jersey; Porterfield O'Neal, Ashland, Virginia; Annabel Rhoads, Oakville, Kentucky; Newman Cook, Bovina, Mississippi; Rufus McCaul, Trenton, Tennessee; Leona Miller, Roselle, New Jersey; Irene Kitsmiller, Grangeville, Idaho; Ethel Deardorf, Washington, D. C.; Jerry De Young, Theresa, New York; Ressie Chubb, Tacoma, Washington, and Ruth Green, Belgrade, Montana.



Monthly Prize Contest

THIS month our prizes are for verses. *Subjects:* "Let's Pretend" or "The Message of Spring" or "May Flowers" or "The Doll I Love Best" or "Out for a Sail" or "The Morning Dew." This is a splendid list from which to choose. You may write a poem on two or more subjects if you like. For the ten best verses we will give prizes of paper dolls, water-color paints, books, post-card albums, pocket-knives. For the five best drawings on any subject which you may select we will give prizes of books and paints. The contest is open to all boys and girls under seventeen years of age.

Please write on one side of the paper only, and put your name, age and address at the top. Your work must be original. The contest closes May 2d. Address Cousin Sally, care of FARM AND FIRESIDE, 11 East 24th Street, New York City.

Prize-Winners in February 10th Contest

EMMMA PETERSON, age fifteen, Minden, Nebraska; Edna Timmel, age thirteen, Oconomowoc, Wisconsin; Lottie W. Cater, age thirteen, St. Cloud, Minnesota; Flossie Marchmont, age twelve, Villa Rica, Georgia; Paul R. Loomis, age thirteen, Rock Branch, North Carolina; Lilly L. Larsen, age thirteen, Laurel, Oregon; Olive Mangold, age fifteen, Carrollton, Pennsylvania; Anna L. Flory, age fifteen, Pequea Creek, Pennsylvania; Adelaide Markert, age thirteen, Lakeville, Minnesota; Wallace E. Chamberlin, age fourteen, Greenfield Centre, New York.

Besides these hundreds of pictures were give to the boys and girls under twelve years of age who guessed all the answers to the puzzles. The cousins who were twelve years old and those who did not give any age, were not considered. The answers were Troy, Tacoma, Bridgeport, Dallas, Hartford, Salem, Norfolk, Denver, Washington, Newark, Reading and Omaha.

Cousin Sally's Club

DO you boys and girls want to join a big, helpful, fun-loving club? Do you want to wear on your coat a button that you will be proud of? Do you want to be a helper in the world and do something to cheer and gladden others whose lives are not so happy as yours? And do you want to grow up to be just the finest and best type of man or woman who merits the name of "American?" Then I would say to you: "Join Cousin Sally's Club!" We have members in all parts of the United States, and if you are a member and should one day visit in some other city, you may meet a boy or girl wearing one of our club buttons. Wouldn't that be fine? Why, you'd be friends at once—and friends always. The club button costs only five cents. The color-scheme is royal blue and white—blue for loyalty and white for purity. The monogram "C. S. C." stands for Cousin Sally's Club and our motto, which only club members may know. With every button I will send a letter, telling the club's motto and what is expected of members.

When the club was organized, I knew it would grow to be one of the largest children's clubs in the United States, and from the increasing demand for buttons I feel sure that my dreams and ambitions are being realized.

Isn't it nice to feel that you are doing a little good in the world—no matter how little that "good" is? It doesn't cost anything to pluck a flower from that precious garden of yours and take to the lonely little shut-in who lives down the road, who never knows what it means to get out into the sunshine and breathe the sweet spring air as you do.

It's just as easy to say a kind word instead of an unkind word! And it doesn't hurt to help mother, when she does so much for you. I tell you, dear little friends, it is the boy and girl with a bright, smiling face and who always says kind things that the world loves and needs. So, if you join the club, you will find that it helps you in many ways.

But don't think that our club is all work and no play, for we certainly do have a great many jolly good times together. "All work and no play made Jack a dull boy," and we want no dull boys in Cousin Sally's Club.

Send your request for the button on a separate sheet, if you are entering contest, and state age. Address Cousin Sally's Club, care of FARM AND FIRESIDE, 11 East 24th Street, New York City.

Our Puzzle School

Conducted by Sam Loyd

Aladdin's Wonderful Lamp

HERE is a puzzle that will prove equally interesting to young and old, even though it does require a little thought and patience.

Of course, all good children, and their parents as well, have read about Aladdin and his wonderful lamp; how with its aid he could do anything that he desired. He could turn anything into something different. Now here is your chance to prove yourself almost as clever as Aladdin himself.

First cut out the five pieces as shown and arrange them into one large pyramid, then rearrange them so as to make two pyramids. Again rearrange them so as to make two squares, after which show how Aladdin made them all into one big square. If this is done correctly, it will show how Aladdin performed four of his most wonderful and clever tricks.

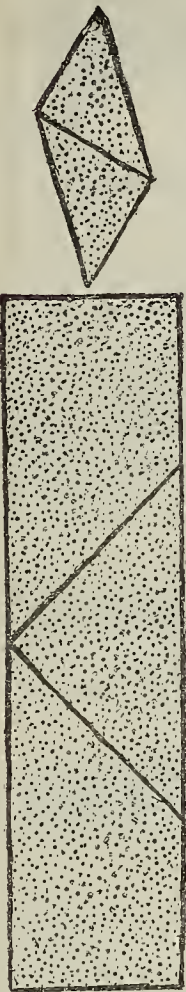

A Charade

If you a journey ever take,
No matter when or where,
My first would surely have to pay
Before you can get there.
My second you would scarcely see
If London through you go;
But still 'tis what I hope you are;
Few better things I know.
I say my whole with secret pain,
Though hoping soon to meet again.

Quite Mathematical

Biddy was very sensitive on the matter of her age. So for the last twoscore years she has invariably answered queries pertaining to her earthly sojourn by the following little verse, which was doubtless quite correct when first perpetrated:

Five times seven and seven times three
Add to my age and it will be
As far above six nines and four
As twice my years exceeds a score.

Can you tell how old the census man figured out the age of Biddy?

Brain Sharpeners

Where lies the path of duty? Through the Custom House.

Why should turtles be pitied? Because theirs is a hard case.

When does a ship tell a falsehood? When she lies at the wharf.

Why should the male sex avoid the letter A? Because it makes men mean.

Why should young ladies set good examples? Because young men are so apt to follow them.

Why should you never tell a man to take a back seat? Because, if you do, he'll be likely to take affront.

What is the difference between a hungry man and a glutton? One longs to eat and the other eats too long.

Why must chimney-sweeping be a very agreeable business? Because it suits (soots) every one who tries it.

Why is a baby like wheat? Because it is first cradled, then thrashed and finally becomes the flower of the family.

Why is a joke less durable than a church-bell? Because after it has been told (toll'd) a few times it is worn out.

Why is Ireland likely to become the richest country in the world? Because its capital is always doubling (Dublin).

Why are crockery-ware dealers different from other merchants? Because it won't do for them to crack up their goods.

Tom went out, his dog with him; he went not before, behind, nor on one side of him, then where did he go? On the other side.

What is the difference between a mother and a barber? The latter has razors to shave and the former has shavers to raise.

What becomes of the chocolate-cake when your only son eats it? It vanishes into the empty heir (air).

Concealed Geography

In the following sentences the name of some town or country is concealed between two words. Can you guess them?

34. It is the belief of the ancients that heroes' souls soar to islands of the blessed.

35. He has my R. N. as a monogram on all his note-paper.

36. He brought horses to Hannah, antelopes to Carrie.

37. A Psyche in marble he adored as if alive.

38. I am her stupid sister.

39. Kate can't tell a wren cemented, from a wren demented.

40. In adjusting the baby-jumpers, I adjusted the baby, so that it fell out. (A country.)

41. The calmest man is sometimes made irate. (An island.)

42. Away they went and over the race-course spuu.

43. The sale must commence at one o'clock.

44. Would you bid a cow or ox bury their dead?

45. What do you call Mr. Rarey? A horse-tamer, I call him. (A country.)

46. The only animal taken was a Kangaroo. (An island.)

47. The moment I waked I saw three crows on the bedpost.

48. After singing a "te deum," bag, O soldier, your booty. (A lake.)

49. The Ojibbeway retired and the Mosquito led on his troops.

50. They made a hue-and-cry, but, ah, of no avail. (A state.)

51. You should see Parepa Rosa cram entomological specimens into her hand-box.

52. Socrates considered a warming-pan a matchless affair.

53. King William wrote a letter to a hunter.

A Puzzling Query

Here is one of the old-time rebus puzzles of the days of our granddaddies.



The question is to tell how we know that this man is preparing a great feast?

Guessing-Match

A guessing-match about cats is entertaining. Write out the following list for each competitor without giving the answers, which are here printed in parentheses, and the ones guessing the largest number wins:

- An aspiring cat (catamount).
- A cat that can swim (catfish).
- A cat that can fly (cat-bird).
- A cat that will be a butterfly (caterpillar).
- A cat's near relations (catkin).
- A horned cat (cattle).
- A cat that throws stones (catapult).
- A tree cat (catalpa).
- A water cat (cataract).

Answers to Puzzles in February 10th Issue

The florist had a 50-cent piece and a 25-cent piece. They pooled all their money, then the florist takes the \$1. the 5 and two 2 cent pieces; the lady the 50, 10, 10 and 1, and the boy 25 and 3, which gives each their proper change.

Concealed Geography gave the names Ravenna, Cairo, Damascus, Naples, Saco, Taunton, Bethel, Buffalo, Dover, Ely, Skagerack, Frankfort, Mobile, Paris, Denver, Nineveh, Trenton, Beersheba, Gorham, Bethlehem and Hartford.

The Twenty-One Palindromes are Anna, Eve, Ada, nun, madam, bib, pap, gig, level, ewe, noon, eve, pop, pup, pip, mum, gog, eye, tenet, peep and deed.

There would be forty-two pieces in that cheese.

Decapitation Puzzle employs the word "shark."

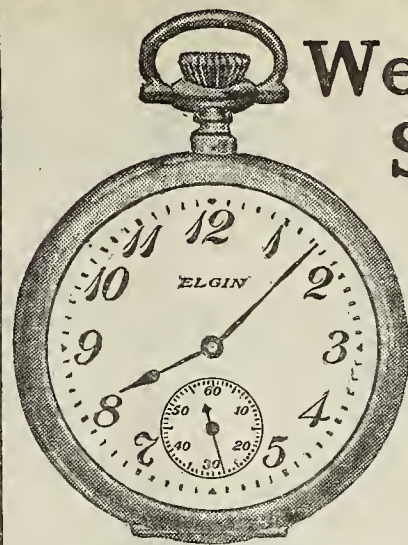

We Will Help You Select a Watch

In buying a watch, even the reliable Elgin, let it be a model that meets your special needs.

One very popular Elgin model is the G. M. WHEELER grade. While its price is moderate it has all the accuracy for which all Elgin watches are so famous.

It may be that among our many other

G. M. WHEELER GRADE
Popular 78 Dial. 17 Jewels.
Open Face and Hunting Case.
Made in Standard Sizes.

Elgin

models there is some one grade even better adapted to your special needs. We will help you select your watch if you will first write us outlining your requirements and giving your occupation. We will carefully consider what you tell us and will write you fully, explaining *without any cost to you* the particular Elgin you need, and will tell you where you can get it.

In this way you are assured of a service unobtainable elsewhere at any price. Write to-day.

ELGIN NATIONAL WATCH COMPANY, Elgin, Ill.

Get this catalog and save 25%—40%

Don't think of buying a buggy until you see the big 1910 MURRAY Style Book of vehicles and harness—the most complete published—contains 192 pages, 345 illustrations, including the new

Murray Highest Award Auto-Buggy

In this buggy you get 7 valuable features contained in no other buggy, and save two profits—save middleman's profit and save on the prices offered by all other makers. Sold on trial, guaranteed two years. Safe delivery insured. Get catalog for details—it is Free.

THE WILBER H. MURRAY MFG. CO., 322-328 E. 5th St., Cincinnati, Ohio

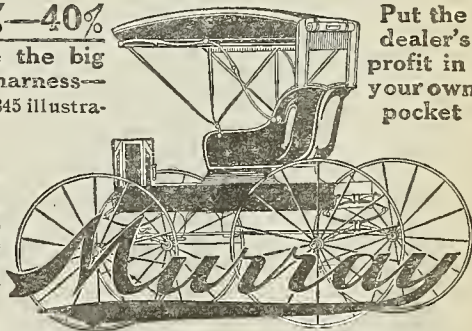

Put the dealer's profit in your own pocket

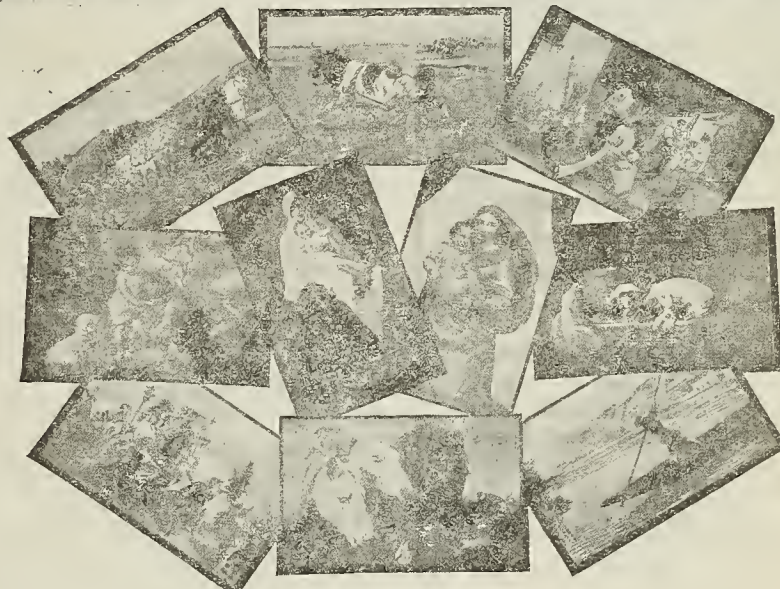

A Few of the Famous Pictures

The World's Most Famous Paintings On Post-Cards Without Cost to You

FIFTY of the most famous paintings in the world have been reproduced on post-cards for FARM AND FIRESIDE readers. You can get them all without cost, as explained in the offer below. Every picture is in twelve colors and is an art masterpiece itself.

These are not ordinary post-cards at all—you have never seen such beautiful cards. They represent the greatest perfection ever attained in post-cards. You here get 50 of the greatest paintings in the world, each one shown in all its original colors. The originals of these paintings hang in the famous art-galleries of Europe.

WE show here miniatures of only ten of these Famous Pictures. You will receive a set of 50—all different, every one a famous masterpiece, every one printed in twelve colors, every one an exact reproduction of the original painting. Accompanying each picture is a description of the painting, together with the name of the artist and the name of the art-gallery in which the picture hangs. To have this set of 50 great pictures with the accompanying description of each is to have in your own home the world's art masterpieces. Never before has so valuable a set of post-cards been offered by any paper.

How to Get Them

We will send you this complete set of 50 Famous Paintings Post-cards without cost by return mail if you will send two 8-month trial subscriptions to Farm and Fireside at 25c each. One may be your own. Don't fail to get them.

Use That Coupon
FARM AND FIRESIDE
Springfield, - - - Ohio

FARM AND FIRESIDE
Springfield, O.
Gentlemen:—
Please send me the Famous Paintings Post-cards. Send Farm and Fireside for 8 months to the names below for which I inclose 50 cents.
Yours truly,

Many a Clever Housewife

Has learned that to
serve

Post Toasties

Saves worry and
labor, and pleases each
member of the family
as few other foods do.

The crisp, dainty,
fluffy bits are fully
cooked—ready to serve
from the package with
cream or good milk.

Give the home-folks
a treat.

"The Memory Lingers"
Pkgs 10c. and 15c.

Postum Cereal Company, Ltd.,
Battle Creek, Mich.

The Housewife's Letter-Box

We shall be glad to have our readers answer any of the questions asked, also to hear from any one desiring information on household matters. We want this department to prove helpful to our readers, and from the letters we have received we feel sure that our aims have been realized. While there is no payment made for contributions to these columns, still our readers may feel that their help and assistance is doing a great deal for others. All inquiries and answers should be addressed to "The Housewife's Letter-Box," care of Farm and Fireside, Springfield, Ohio.

Questions Asked

L. J., Ohio, would appreciate a recipe for brown bread, bag pudding and batter pudding. The recipe for old-fashioned corn-pone is given in this issue.

Virginia Lassie would like to have some one tell her how to exterminate roaches.

Mrs. S., Nova Scotia, is at a loss to know why cream turns bitter before churning, and afterward the butter becomes rancid. She says that the milk when kept for a couple of days shows no sign of turning rancid. Can some one help her?

Mrs. G. DeM., California, would like to know how to remove grease-spots from wall-paper and a good recipe for caramel-cake.

I am anxious to obtain the pattern of the tulip quilt. I've lost mine and would be glad to have some reader send it to me. L. A. P., Pennsylvania.

Can some one tell me what is wrong with my canned tomatoes. They look nice and red and are not moldy, but contain so much acid that sugar will not sweeten them. The tomatoes are in tin cans and glass and stone jars, but still they contain so much acid. Mrs. J. M. H., Ohio.

I would appreciate a recipe for preparing Saratogo potatoes. K. D. C., Pennsylvania.

Will some reader please tell me how to cook egg-plant? E. S., New York.

Can some one tell me how to color furs and other skins black? J. S., Ohio.

I would like to know how to make, from either granulated or brown sugar, syrup that will not granulate. I have to make it too thin, or else it goes to sugar.

I would also appreciate directions for hardening tallow for candles. Miss E. R., Ohio.

Mrs. C. L. F., Kansas, would like to know: 1. How to keep the brass fixtures of gas-lights looking bright and new. 2. How to keep a nickel base-burner bright in summer. 3. How to keep dish-towels white.

M. E. S., Kansas, would like to know how to remove ink-stains from table-linen.

Questions Answered

Miss A. C. Phelps, Massachusetts, sends in the following answer to "A Subscriber," Wisconsin: "Perhaps you make your chocolate-frosting too stiff. I generally use cocoa, about two tablespoonfuls, according to the size of the cake; one half cupful of granulated sugar, and three or four tablespoonfuls of milk. Put in bowl and steam over the tea-kettle until all is dissolved and glossy. Then add vanilla and when cold spread on cake. If it looks too dull, dip a case-knife in cold water and then spread frosting, dipping the knife in the water as often as necessary.

FROSTING FOR CHOCOLATE-CAKE, for A Subscriber, Wisconsin—The icing will be shiny if bitter chocolate is used.

Take one cupful of granulated sugar, with just enough water to moisten, and let boil until it threads when dropped from a fork. To this add three heaping tablespoonfuls of chocolate, moistened first with a little hot water, and let all boil up well. Then pour over the beaten white of one egg, heating slowly until it is thick enough to spread. Then flavor with vanilla. I have used this recipe a long time. If a plain boiled frosting is desired, omit the chocolate. I hope "A Subscriber" will find this recipe helpful.

Mrs. E. H. P., California.

For Mrs. C. G., New York—Mix four quarts of salt, four pounds of light brown sugar and four ounces of saltpeter to one hundred pounds of beef. Sprinkle some of the mixture on the bottom of cask, put in a layer of meat, then more of the mixture, and so on, then weight. It will make its own brine. Leave in brine four or five weeks and dry. Before the fly makes its appearance tie it up in twenty-five-pound sugar-sacks and place sacks inside paper flour-sacks. Keep in as even a temperature as possible. In very damp weather it may mold, so it should be taken out, thoroughly washed with cold water and a little vegetable brush, dried, put into clean sacks and stored away. I have tried various methods such as ashes, salt and oats, but this has proved the most satisfactory and the least troublesome. I have kept it from March until November in this manner.

Mrs. S. E. J., Ohio.

D. S., Kansas—Mrs. E. C., Ohio, noticed that you asked for directions for washing white plumes, so she sends in the following information which may prove of help

to you. Take gasolene and corn-starch and make a real thin paste of it. Put the plumes in and shake them up and down for about five minutes, running the fingers through the flues. Then take them out in the air and shake them until they are dry. Repeat the process about four or five times. Keep the plumes away from the fire for a day, then shake them over a hot stove and they will become fluffy and soft. Don't clean them near a fire, as the gasolene is highly explosive.

Wit and Humor Ma's Tools

AT HOME it seems to be the rule
Pa never has "the proper tool"
Or knack to fix things. For the stunt
That stumps ma, though, you'll have to hunt.

The caster in the table leg
Fell out. Pa said a wooden peg
Would fix it up. But ma kep' mum
An' fixed it with a wad of gum.

We could scarce open our front door,
It stuck so tight. An' pa, he swore
He'd "buy a plane" as big as life—
Ma fixed it with the carving-knife.

The bureau drawer got stuck one day,
An', push or pull, 'twas there to stay.
Says pa, "Some day 'twill shrink I hope."
Ma fixed it with a piece of soap.

The window-shade got out of whack,
'Twould not pull down, nor yet roll back.
Pa says, "No one can fix that thing."
Ma fixed it with a piece of string.

I broke the stove-door hinge one day.
'Twas cracked before, though, anyway.)
Pa said we'd put a new door in.
Ma grabbed her hair an' got a pin.

The bath-tub drain got all clogged up.
Pa bailed the tub out with a cup—
He had a dreadful helpless look.
Ma cleaned it with a crochet-hook.

One day our old clock wouldn't start.
Pa said he'd take it all apart
Some day an' fix the ol' machine.
Ma soused the works in gasolene.

So when my things gets out of fix
Do I ask pa to mend 'em? Nix!
But ma just grabs what's near at hand
An' togs things up to beat the band.
JESSIE T. CLAPP.

Rather Disconcerting

"MAMA," said little Ethel, with a discouraged look on her face. "I ain't going to school any more."
"Why, my dearie, what's the matter?" the mother gently inquired.
"Cause it ain't no use at all. I can never learn to spell. The teacher keeps changing the words on me all the time."—Success Magazine.



For The Overworked Woman

or the one who
would rather do
one hour's easy,
pleasant work
than hire a wash
woman for a whole day.
One hour of light,
easy work, that is all
that the biggest wash-
ing means to the
woman who
has an

O. K. WASHER

Let us prove to you that the O. K. Roller Gearing Rotary Washer is the easiest to operate; that it cleans the clothes quickest; is easiest on the clothes, never injuring the most delicate fabric; that it lasts longest, and that, in every way, it will save you more work and give you better satisfaction all around than any other washer, regardless of price.

Guaranteed to You

Our legally binding guarantee is tucked inside the machine. Guaranteed because it is mechanically perfect, a child turns it easily, legs never wobble, being formed of lengthened staves huilt in with the tub, steam-proof lid keeps water hot. Don't ruin health and disposition over the wash tub when this complete relief is at hand for so little money. Write for our free washer hook. We'll tell you how to buy the right washer at the right price.

H. F. Brammer Mfg. Co.
1452 Rockingham Road, Davenport, Iowa

This contractor got results

He knew how to feed his men.
Some years ago a contractor building a railroad in a warm climate was troubled a great deal by sickness among the laborers. He turned his attention at once to their food and found that they were getting full rations of meat and were drinking water from a stream near by. He issued orders to cut down the amount of meat and to increase greatly the quantity of Quaker Oats fed to the men. He also boiled Quaker Oats and mixed the thin oatmeal water with their drinking water. Almost instantly all signs of stomach disorders passed and his men showed a decided improvement in strength and spirits. This contractor had experience that taught him the great value of good oatmeal.

53

Test "IMPERIAL" 30 an In Your Own Home at OUR RISK



If it does not prove the best
looker, cooker and baker you
ever saw, send it back at our
expense.
Direct from factory to you
at WHOLESALE PRICE.
Freight prepaid.
Has exclusive features
not on any other range—
such as Stone Oven Bot-
tom, Odor Hood, Oven
Thermometer, Ash Sif-
ter, etc., etc.
Easy credit terms if wanted.
Write to-day for Free Cata-
log and prices.

The Imperial Steel Range Co., 868 State St., Cleveland, Ohio

The Mechanical Wash-board

Always remember
the name **G** GRANDMOTHER rubbed, mother rubbed,
and you rub too, but here is a machine
that will rub for you.



Other machines pound, tumble, or churn the clothes. They do not rub them and that is the only way to get them clean. The Boss rubs and squeezes the clothes between two rub-boards just as when washed by hand. The scalding suds are forced through every thread. The loosened dirt drains into a special chamber away from water and clothes,—an exclusive feature. Every piece from lace curtains to blankets comes out spotlessly clean. Not one is worn or torn.

A child can operate the Boss, or you can run it with a gasoline engine or any other light power. Lasts a lifetime. Successfully sold for 20 years. Over a million in use.

Write for booklet giving wash-day hints, showing wash-day in all countries, and telling how you can try the Boss in your own home at our risk.

The Boss Washing Machine Co.,
Dept. 21, Norwood Station, Cin'ti, O.



The pure, high grade scientifically blended cocoa made by Walter Baker & Co. Ltd., and identified by the trade-mark of the Chocolate Girl, acts as a gentle stimulant and invigorates and corrects the action of the digestive organs, furnishing the body with some of the purest elements of nutrition.

A beautifully illustrated booklet containing a great variety of recipes for home made candies and dainty dishes, sent free.

WALTER BAKER & CO. Ltd.
DORCHESTER, MASS.
Established 1780

TRAVELING SALESMEN
EARN BIG SALARIES
From \$1,000 to \$10,000 a year and expenses. If you want to enter the easiest, best paid profession in the world, our free catalogue, "A Knight of The Grip," will show you how. We place thousands of our graduates in good positions with the best firms all over the United States and Canada. Write or call for particulars today. Address nearest office. Dept. 429, NATIONAL SALESMEN'S TRAVELING ASS'N Chicago Kansas City New York Minneapolis San Francisco Atlanta

GET TELFERS NEW 1910 RUG BOOK
Showing newest 1910 designs in carpets, rugs, linoleums, lace curtains and portieres in actual colors. We ship direct, freight paid. Order by mail.
SAVE \$5 TO \$10 on every carpet and room size rug you purchase. Get better goods, later styles, better values. Send postal today and get our magnificently illustrated catalog and liberal freight proposition.
60 Pages 150 Color Plates
FREE
TELFER CARPET CO.
820 Walnut St. Des Moines, Ia.
We Pay Freight

Here Is Something New From Kalamazoo
Prove for yourself in your own home, that the Kalamazoo is the most perfect—most economical—most satisfactory range for you to use—Your money back if it's not.
Send for Catalog No. 183 with special terms and compare Kalamazoo prices with others
Cash Or Time Payments
We want every housewife to know the comfort and convenience of a Kalamazoo in her home. You can buy on easy time payments or pay cash if you like. Either way—you save \$10 to \$20 on any stove in the catalog. We make it easy for responsible people to own the best stove or range in the world.
We Pay the Freight
Kalamazoo Stove Co.
Kalamazoo, Mich.
A Kalamazoo Direct to You

Our New Premium Offers

Handsome Prizes Easier to Get Than Ever Before

NEVER before has FARM AND FIRESIDE made it so easy for its friends to obtain these great premiums. All you have to do is to ask a few friends to give you 25 cents for a trial subscription to FARM AND FIRESIDE. Through you they can obtain an eight-month subscription to FARM AND FIRESIDE for only 25 cents, although the regular price for an eight-month subscription is 35 cents. You can easily get a dozen subscribers in an afternoon.

Handsome Sugar-Shell Given for only Three 8-month Subscriptions at 25 cents each

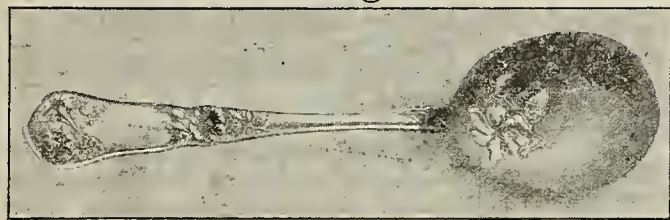

This handsome sugar shell is made by the famous Oneida Community. It is the Wild-Rose pattern and matches the spoons shown below. It is a desirable, good-looking piece of silver and

has the famous gray finish. It is the very finest style. You could not help admiring it. It will delight you with its richness and beauty. It is guaranteed for ten years. It is heavy and elegant and has all the richness of the solid silver.

The Famous Tension Shears

Given for only Four 8-month Subscriptions at 25 cents each

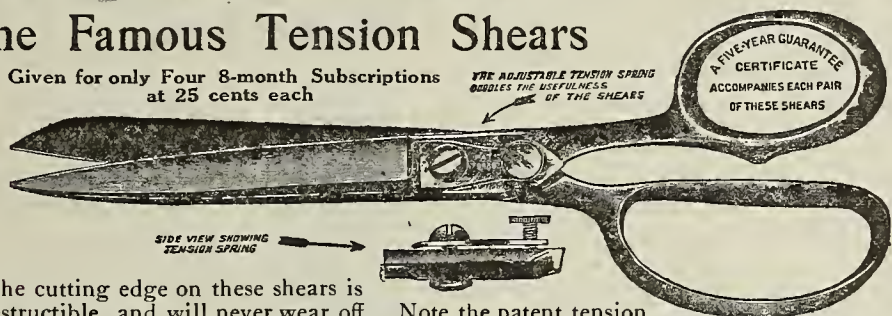

The cutting edge on these shears is indestructible, and will never wear off. Note the patent tension spring, which does away with re-sharpening. These shears are 8 inches in length, made of highest grade steel, perfectly tempered and heavily nickel-plated. A simple turn of the thumb-screw will adjust the blades to cut anything from wet tissue paper to a horse blanket. Your shears will never be dull, and they are guaranteed by the makers for five years.

Two-Bladed Pocket-Knife

Given for only Four 8-month Subscriptions at 25 cents each

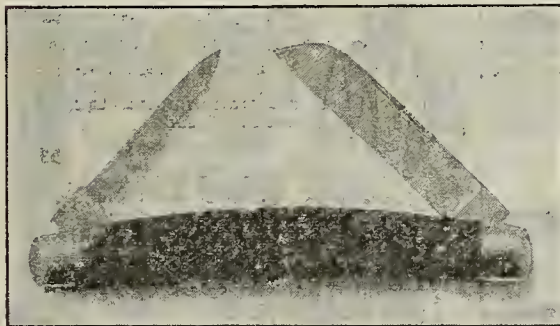

This is a strong, well-made, durable knife, suitable for ordinary usage, and appropriate for every one. The handle is of stag and the tips of German silver. It has one large and one small blade, both welded from good steel. This knife is intended primarily for the boy's use and it is for this purpose that we recommend it.

Handy Fountain-Pen

Given for only Four 8-month Subscriptions at 25 cents each

Every one needs this Fountain-Pen. You can get one without cost.

You will be delighted to have so fine a fountain-pen. You will use it many times a day. It is the most convenient pen that any one could have. This one is guaranteed to write well.

The Handy Fountain-Pen is the best pen made for usefulness and wearing qualities. It has a

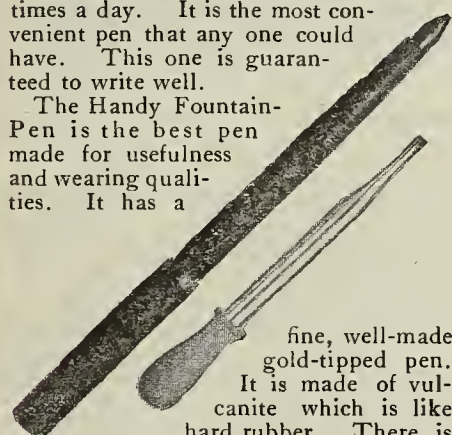

fine, well-made gold-tipped pen. It is made of vulcanite which is like hard rubber. There is a close fitting dust-cap to protect the pen-point. It is easily filled and a filler is furnished with each pen. The special feature of the Handy Pen is its free flowing ink, requiring no shaking.

King Air-Rifle

Given for only Eight 8-month Subscriptions at 25 cents each

Boys have use for it every minute — hunting in the woods, shooting at targets, drilling as soldiers, and innumerable uses that only boys can discover. Every boy can get one of these rifles without cost.

A True Shooter

The King Air-Rifle is a repeater. It shoots 150 times without reloading. It is strong, durable and shoots accurately. It cultivates trueness of sight and evenness of nerve.

This rifle is harmless. It uses no powder—just air. There is no smoke, no noise. Air is plentiful and shot costs but 10 cents for ,000.

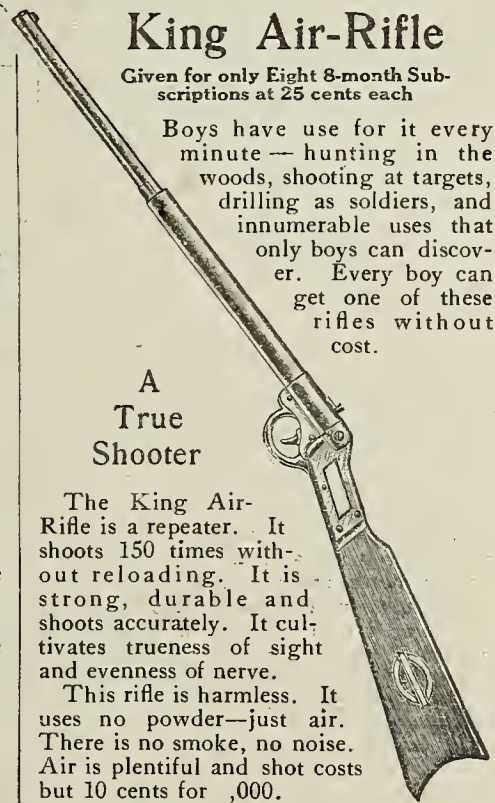

Noah's Ark Animal Cut-Outs

Given for only Three 8-month Subscriptions at 25 cents each

These Cloth Cut-Outs are very popular among the children because all children are fond of animals. This sheet, 19 by 28 1/2 inches in size, has four complete animals printed upon it in colors, and when sewed and stuffed will outlast many times the child's other toys.

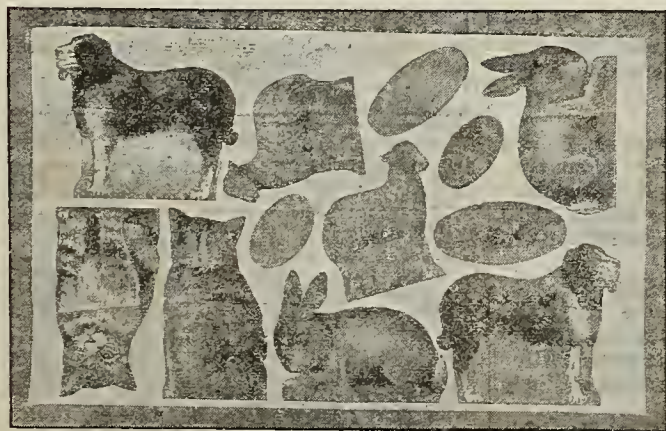

JUST look at these magnificent rewards. We are sure you would be delighted to have some of them. FARM AND FIRESIDE guarantees each one to give satisfaction. It will be better than you expected. You can easily get them without costing you one penny. Show FARM AND FIRESIDE to your friends. Tell them how your folks like it—that it is the biggest, best and handsomest farm and family journal in the country. They will be glad to take a trial subscription.

The Lenox Plant-Sprayer

Given for only Four 8-month Subscriptions at 25 cents each

Spraying Means Lots of Flowers

The Lenox makes a misty shower like a good dew. It gets on the under side of the leaves, works like an old-fashioned lemon squeezer. You can either drench or moisten lightly—out doors or in doors.

A cake of Tobacco Soap included with each sprayer.

Spraying with tobacco water, particularly on the underside of the leaves destroys the rose bug and its eggs; in fact, all sorts of insects, like the red spider, mealy bug, green fly, mildew, etc., on vines, plants, in the flower-bed, strawberry-patch, or in the family garden.

Useful in hundreds of other ways. This sprayer can be used for sprinkling clothes, whitewashing, disinfecting rooms, animals, birds, etc., etc. It is a necessity in every home. YOUR PLANTS NEED IT.



Weeden Steam-Engine

Given for only Six 8-month Subscriptions at 25 cents each

Every boy wants a Steam-Engine, and here's the best one in the market, the well-known, guaranteed Weeden Engine. It has all the parts of a regular engine, fly-wheel, cylinder, piston, whistle, etc., and is a practical and instructive toy for any boy.

An Engine That Runs

Every engine is tested before it leaves the factory and is in good running order when it leaves our hands. We can furnish duplicate parts in case of accidental breakage. Every real boy at some time in his life wants a mechanical toy. He wants to see the wheels go around. That's why you should get this engine for your boy. You get it for nothing, and it will be a lot cheaper to let him tinker with this engine than to take his father's watch apart to see how it works.

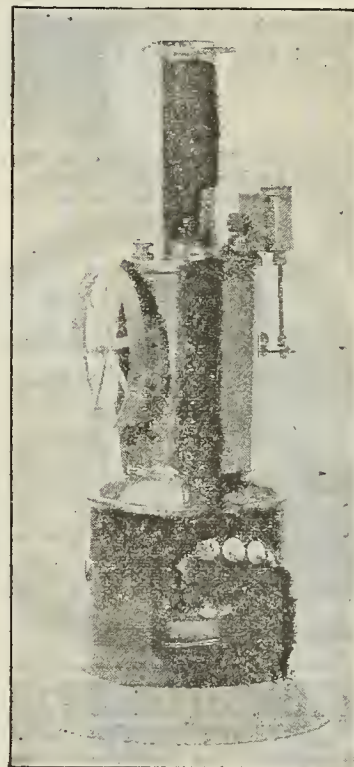

Silver Teaspoons

Given for only Eight 8-month Subscriptions at 25 cents each

These teaspoons, also, are made by the Oneida Community, and are guaranteed for ten years. The Wild-Wood pattern is elegant and chaste. These spoons are heavy and slightly, and have all the richness of the solid-silver article.

This is certainly the most beautiful design for silver spoons we have ever seen. It requires an expert to tell the difference between these spoons and regular Sterling ware.

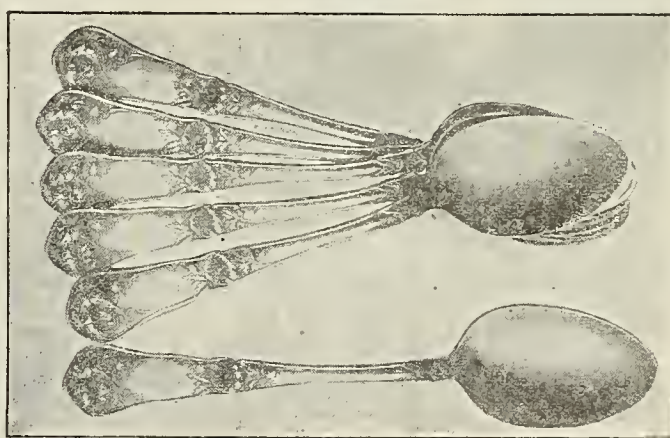

Men's Sheepskin Purse

Given for only Three 8-month Subscriptions at 25 cents each

Any man would be delighted to have a purse like this. Here is a substantial, durable purse for the man. This purse is made of stout sheepskin, and is well sewed and strong. It has two compartments for currency and bills and is just the thing for every-day use. The purse is much larger than the cut, twice as large in fact, and is an ideal article for the farmer's use.

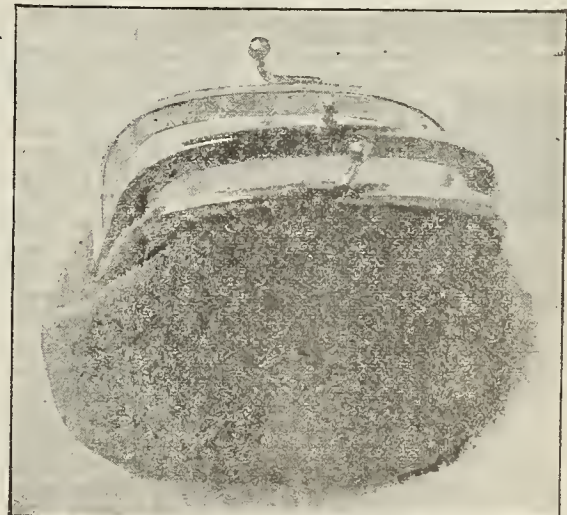

Send your orders to FARM AND FIRESIDE, Springfield, Ohio

Panhandle Land At \$10⁰⁰ an Acre

Plenty of it at that price and some of the best for \$20. Enough rain, just at the times you need it, to produce big profit—grass and alfalfa crops three times a year.

Enough sunshine in between to yield an average of 30 bushels of corn—8 tons of sorghum cane—800 pounds of beans—over a ton of broom corn—20 bushels of wheat—no less than 30 bushels of oats, rye and barley and 100 bushels of potatoes to the acre.

Pumpkins, melons, fruits, garden vegetables—big crops of cotton—minus the boll weevil. No disease among cattle, hogs, sheep and poultry. No pests in your orchards or fields.

Million of Acres

of unimproved land in Northern Texas, Northwestern Oklahoma, Northeastern New Mexico and Southwestern Kansas. Near the big markets, therefore low freight rates.

Send me your address. I'll tell you all about the Panhandle and other good lands at low prices in other Rock Island territory. Let me point you to success.

Tell me the sort of farming you prefer and I'll tell you where conditions are ideal to make more money with less hardships than you can on high priced land at home.

Low excursion fares first and third Tuesdays of each month.



L. M. ALLEN, Passenger Traffic Manager
235 La Salle Station, Chicago

They die outdoors!

No mixing
No Spreading—
No MESS—No Trouble
Just crumble up a
Rat Bis-Kit
about the house. Rats will seek it, eat it, die outdoors. Easiest, quickest, cleanest way.
See all druggists, or direct prepaid.
The Rat Bis-Kit Co.
45 N. Limestone St.
Springfield, Ohio

\$360 TOMBSTONES \$385⁰⁰ AND MONUMENTS FINE ARTS IN STONE CRAFT DIRECT FROM QUARRY TO CEMETERY



This Dark Barre Granite Monument for \$69.95
More than 500 other kinds, styles and sizes in granite and marble at \$3.60 to \$385.00. If you want the best in stone craft at quarry to cemetery prices, write for our Tombstone Catalog No. 72F38

SEARS, ROEBUCK AND CO., CHICAGO, ILL.

ANCHOR FENCE

means fence satisfaction. A fence easy to put up, that is made right and that lasts.
Free Sample and Catalog.
ANCHOR FENCE & MFG. CO., Dept. D Cleveland, O.

LAWN FENCE

Many designs. Cheap as wood. 32 page Catalogue free. Special Prices for Churches and Cemeteries. Coiled Spring Fence Co. Box 403 Winchester Ind.

ORNAMENTAL FENCE

25 DESIGNS, ALL STEEL Handsome, cheaper than wood, more durable. Special prices to churches and cemeteries. Don't buy a fence until you get our free catalog. Kokomo Fence Machine Co. 427 North St., Kokomo, Ind.

FENCE News and Prices

Do not buy a foot of fence till you have procured our Prices and Free Book on Metal Fence, from the finest "ornamental" styles down to "cheaper-than-wood" kinds. We save you money. Hundreds of styles. Get Free Catalog.
The Ward Fence Co., Box 176, Decatur, Ind.

14 1/2 Cents a Rod

For 22-in. Hog Fence; 15 3/4-c for 26-inch; 18 3/4-c for 31-inch; 22-c for 34-inch; 25-c for 37-inch Farm Fence. 50-inch Poultry Fence 33-c. Sold on 30 days trial. 80 rod spool Ideal Barb Wire \$1.55 Catalogue free.
KITSELMAN BROS., Box 272 MUNCIE, IND.

Old Man Potter

[CONTINUED FROM PAGE 26]

him. "Yes, pa, home with me, away from all you've put up with for five years. My, how I've cried over you, pa, till 'seems tho' I couldn't stand it one day more, and Dave says yesterday, 'I'll stay with the kids Saturday and you go and fetch him. And I'm goin' to take you back, too, either you or your signed promise you'll come next week. Oh, I just plain can't stand it—to think of you here, all alone, and gettin' old!"

"I ain't feelin' old," he protested. "I ain't complainin'."

"I know you're not, and better for you if you did complain sometimes, I'll bet! Anyway, you're a-comin' with me!"

"I kind of feel I'm needed here, dearie," the old man answered quickly, but how firmly Rosie knew only too well.

"Needed! Who needs you? Not her, that's certain! And as for Walt—" she hesitated.

"Yes, Walt," answered her father, as if she had conceded him his argument.

But indignation flared in her eyes, an indignation reaching back into her childhood's days of impatience with a spoiled little brother. "What's Walt done that you should wait on him till you die? Let him look after himself for once. He's never done one thing for himself all his life, except get married, and that was the poorest job he could have done!"

"Rosie, you warn't never very patient," reproved her father mildly.

"And I ain't patient now, and I ain't never goin' to be patient so long as you stay here, pa!" but entreaty and sweetness trembled through the fiery impatience of her words. She held his hands tight. "Come home with me, pa," she pleaded, and to his eyes her woman's face was just his little girl's of years ago, imploring him, so that he could not look at her. He dropped his tired lids as he silently shook his head.

"But the children," she still begged, "why, pa, you've never hardly seen the children, 'cause of thinkin' you always had to stay here by the mill; and you were always so soft over babies! They'd keep you cheered up, the five of them! And the baby, oh, pa, the baby! He's as lively as that kitten and just as cute!"

"Tain't because I don't want to come, Rosie!" he faltered.

"Then what is it, pa?" He groped for an excuse. "Maybe I'd get lonesome, there in town. I'm used to the country. I'd kind of miss the pine trees up the holler there, and hearin' the crows. And I'd kind of miss thinkin' of ma down at the house, or seein' her up there gettin' flowers," his voice grew dreamy. "She didn't never seem no older than the May-flowers, and she don't seem so now. I reckon I'd feel easier to stay where ma was."

But Rosie was relentless. "Pa, tell me the truth now. Ain't it the same for you as for me?" Her eyes grew tense in the round, good-humored face. "Ain't it harder to see it all so different from what ma used to have it? When I see the way you try to keep things neat! Don't its being ma's place make it harder than if you was to go away where maybe you could look back and think of it the way it was—with ma? Say, pa, truly, wouldn't you rather go away?"

His face grew pale, his lips worked tremulously without any words. Rosie sobbed into her gay handkerchief, all the mother longing of the empty years came back upon her. At last her father spoke.

"I guess I'd better stay, Rosie." Rosie's face was pinched, the hope with which she had come gone out of it. Still she offered her last plea.

"Pa, don't you think ma would want you should go? Don't you think she'd want you should be happy with me and the children, and you gettin' old? Don't you guess ma'd say you ought to go?"

But at her words his eyes cleared, his lips grew firm, sturdy resolve squared his drooping shoulders, his voice was strong. "No, that's what I'm sure she wouldn't. Ma, she'd say, 'stay here.'"

"Are you sure, pa?" questioned Rosie, wistful, waiting, not understanding.

"I can keep things goin' here. We're doin' pretty good this summer. And Walt, he's no great hand for business, you know. Besides," here he hesitated, looking away from her, seeking an euphemism which might touch but gently the weakness of his boy, "besides, when I'm around, I can keep him from goin' to the hotel so often. He means well, but he's easy—and she, she don't suspicion nothing about that any more than she mistrusts Walt ain't right smart about business. So I kind of guess I'm needed here, Rosie," and he smiled, the old gentle humor touching his lips.

"Oh, pa, I wish you weren't so good! Why shouldn't she know what she's married? She'll have to know some time."

"Not so long as I can help it," he answered firmly. "Why, Rosie, that's all she's got, the way she feels about Walt. She ain't right fond of folks, only Walt, that's all. I should hate for her to lose that," the clear old eyes grew remote, then

brightened with a dream, the deathless dream of his youth. "It kind of seems as if I owe Mate that," he concluded, obscurely.

"Owe that woman what?" questioned Rosie, round-eyed.

Her father looked into her eyes, his own bright and far distant. He was hardly conscious of his words, as he strove for this once to formulate the deep things of his life.

"You're fond of Dave, aren't you, Rosie?" He must try to make it clear to her.

For an instant a glory transfigured Rosie's tearful, commonplace face. "I guess I am!" she answered, with a sharp little laugh.

"Well then," Old Man Potter went on, "this is the way I seem to see it. I owe it to Mate to let her keep on thinking Walt is better than he is as long as she can. I owe it to her because ma believed in me that way. Seems as if I'd ought to pass it on, don't you understand, dearie?"

Rosie nodded, biting back her disappointment with teeth on her lower lip. The old face, ringed with the snow-white curls of hair and beard, was illumined like a boy's. "Ma, she always thought I was all right, and she'd want I should try to let Mate believe Walt's all right, too, as long as I can. I know she'd want I should. One thing ma always thought about me, she used to say I wouldn't run away from anything I thought was right to do. And I ain't never run away yet, on account of her thinkin' that. If I should go with you now, dearie, it would seem like running away. And it would be running away from ma herself, too. Seems if maybe, if I left Walt and Mate I mightn't feel ma so close by all the time the way I do now. Look up the holler there now, see that bunch of laurel? Don't it seem to you to look as if ma was there smelling the ferns the way she used to?"

He paused. Rosie was sobbing quietly, one hand gripping his tight. There was no sound out the gurgling of the brook and the scurry of the kitten's little padded feet across the sun and shadow of the mill floor.

At last the old man went on, speaking quietly and slowly. "Don't you mind, dearie, 'bout me. I don't mind much. 'Tain't so bad. Don't you worry. Only I guess I'd better stay here, don't you, dearie, until ma comes to get me?"

The Mysterious Envelope

[CONTINUED FROM PAGE 22]

Miss Brandon clapped her hands. "Don't you see!" she cried. "When you took the letters from him you took the money—and dropped it down the mail!"

Fisher suddenly sprang to his feet. Trembling with rage, he cried hoarsely, "I can't stand this; I'll tell you all about it."

He looked at the girl and his voice broke. "I did it for you, Kate," he went on chokingly. "I've loved you from the day you first stepped foot in this office; it's terribly bitter to watch you spin the rope that's to hang me."

"Cut that hangin'!" Mr. Sharp broke in with a scowl. "It's only a trip up the river for you."

Fisher sat down again and continued without another look at Kitty:

"I knew they were searching the office and it would be my turn in a minute. 'What was I to do? Here was Miss Brandon and there the police."

"Suddenly I was seized with an inspiration. I picked up one of the big envelopes—it already had a two-cent stamp on it—and wrote my name and address. I meant to put the notes in it and drop it down the mail-chute, knowing that it would be safely delivered at my home in the morning, where I could pay due postage; but right then Miss Brandon offered to address the envelope for me and I was scared out of my wits."

"When she turned to her machine again I had only time to get the notes into the envelope, seal it and mix it with the mail."

"And," concluded the girl, "you put them in the stamped envelope I had addressed to Mr. Truesdell."

"I suppose so," groaned Fisher. "I was nearly crazy when the postman failed to leave the envelope at my boarding-house this morning."

Of the reward, five thousand dollars went to Truesdell and a like amount to Kitty Brandon. But Truesdell was generous; he handed Mr. Sharp the one hundred dollars which Uncle Seth Truesdell had left with Kitty.

That night Truesdell and Kitty went to M. Victor's, who reserved the curtained recess for them. Mr. Beckley had promised the young fellow the long-sought-for "job," and the two were correspondingly happy.

"Kitty," said Truesdell, "that kiss this morning wasn't wasted, after all."

"After all!" she indignantly echoed. "Wasted!"

"And I want one just for its own sake—because I love you, Kitty."

She did not box his ears this time.



Reg. U. S. Pat. Off.

"Turn on the light." My name, Macbeth, on my lamp-chimneys means that I am willing to be judged by them. They're the best lamp-chimneys made and they

do not break from heat.

They are sold by the best grocers.

My book insures your getting the right chimney for your lamp. And it gives general suggestions about the care of lamps. It is free. Send name and address to

MACBETH, Pittsburgh

Wanted

We will present you with a handsome and valuable gift in exchange for a small amount of your time.

We want information of the proposed organization of telephone companies in your part of the country, also names of farmers who contemplate putting in telephones. If you can get reliable information of this kind, write us at once. We guarantee you will be delighted with the gift we will send you.

We sell a high-grade telephone complete for \$10. Anyone can install it and be in constant touch with his neighbors and the nearest town. Our telephones are used by the Government. This proves their quality.

Acme Telephone & Mfg. Co., Dept. 50
Factory and General Offices, Albia, Ia.

Watch Fob Given to Bicycle Riders

Send your dealer's name with 4c postage and we will mail this handsome fob. Also catalog illustrating and pricing our high-grade

Indianapolis
G & J TIRES
Admitted by bicycle manufacturers and riders to be the best made. Wear longest, ride easiest and are most convenient to repair.

G & J TIRE CO.
Indianapolis, Ind.
Address Bicycle Tire Dept.

OREGON ORCHARDS

We are now planting 500 acres apple for last season's buyers in our IRRIGATED LANDS in the Sutherlin Valley Go out with our next Excursion in our Private Car Luseland and see Sutherlin for yourself. We make a special low rate for Railroad Fare, berth and meals. If we may submit our proposition address 221 Germania Life Building.

ST. PAUL, MINN. LUSE LAND AND DEVELOPMENT CO. LD

Fertile Farms in Tennessee \$5 to \$10 per acre

Fortunes are being made on fertile Tennessee farms. They raise big crops of Cantaloupes, Cabbage Tomatoes, String Beans, Green Corn, etc., also Horses, Cattle, Sheep, Swine, Poultry and Eggs. Write me at once for Free Literature. I'll tell you how to get one of these splendid farms for \$5 to \$10 per acre. Act quickly!

H. F. Smith, Traf. Mgr., N. C. & St. L. Ry., Dept. S. Nashville, Tenn.

PATENT YOUR IDEAS

\$3,500 for one invention. Book, "How to Obtain a Patent" and "What to Invent" sent free. Send rough sketch for free report as to patentability. Patents advertised for sale at our expense in fourteen Manufacturers' Journals. Patent Obtained or Fee Returned

CHANDLEE & CHANDLEE, Patent Att'ys
Established 16 Years
935 F. Street, Washington, D. C.

PATENTS-PATENTS Trade-Marks Designs and Copyrights

Booklet containing full information furnished on request.

LANGDON MOORE,
(Formerly Examiner U. S. Patent Office)
524 9th St., Washington, D. C.

Maryland Best in the Union

THIRTY FARMERS are invited to settle in the state of Maryland, where they will find a delightful and healthy climate, first-class markets for their products and plenty of land at reasonable prices. Maps and descriptive pamphlets will be sent free upon application to State Board of Immigration, Baltimore, Md.

Ladies & Gents Watches GIVEN

We give all grades of Watches for selling our Blue Art Post Cards at 10c per pkg. Order 20 pkgs. today. When sold, send us the \$2.00 and we will send you an elegant 5 YEAR GUARANTEED WATCH, also a FINE MIGNET RING and a CHAIN, postpaid, as per our premium list. IT COSTS YOU NOTHING. Write us today.

BELMONT MFG. CO., Dept 90, CHICAGO

PATENTS Inventors Books free. Trade-marks registered.

BEELER & ROBB, 22-26 McGill Bldg., Washington, D. C.

AGENTS WANTED Men or Women to sell Consumers, Big Profits. Groceries, Coffees, Teas, Extracts, Perfumes, Soaps, etc. With or without premiums. Write for catalogue A.

Bushway Flavoring Extract Co., 951 N. Water St., Decatur, Ill.

SUNDAY READING

The Symphony of Life

EVERY human soul becomes at birth a note in the scale and helps to make up the symphony of life. Some notes are deep and strong, others clear, sweet and far-reaching in appeal. They differ in value, pitch and importance, but all give out their tone, and all are essential. They must resound at the touch of the Master of Life—the Great Musician of Soul-Music.

But in order that the symphony shall be perfect in harmony, these notes must be in tune with each other, so that each shall be a part of the perfect whole. They must sound with due regard for each other and the Master's music.

Their value and position in the scale is all indicated plainly and, as the fingers of the Great Musician touch each in turn, he expects to hear a certain note that shall not only be perfect of itself, but shall blend into the Wondrous Melody.

And the Master's fingers never stray, never strike the wrong key. They are sure and certain. If the note is flat or harsh, it is out of tune; and the Master's ear is offended at the response. Then he seeks to remedy the matter.

There are some notes to which are given greater value and perhaps a higher position on the staff; but neither one note nor many can make a symphony; and those that seem least important must link the rest.

Sometimes the fingers of the Player touch softly—then again they seem made of iron, and the instrument groans and wails beneath them. Sometimes it seems as though the melody were drowned by jarring discord, but that is not of the Master's making.

And the notes cannot see the music, which is for the Master's eye alone, nor is it given to them to hear the wondrous sweetness of the melody of which they form a part. But they know that each has its value there in the Music of God.

FANNY MEDBURY PENDLETON.

When Sunshine Counts

ONE'S ability to "keep sweet" is never really tested until he is treated with downright unfairness. There is no credit in being sunny while everything is sunny around us. Any one can be courteous and loving and agreeable while others are so, and while everything that is his right is being given to him. But how many of us make it the deliberate purpose of our lives to be courteous and loving and positively radiant of sunshine when our rights are rudely overridden, and we are ignored or snubbed or even misrepresented? Then, and then only, we have a real opportunity to show whether our Christianity is kept chiefly within the leaves of our New Testament or is the controlling force in our lives. One whose life shines out only more brightly the more his feelings are hurt has little difficulty in persuading others that his Christ is a friend worth knowing.—The Sunday-School Times.

Resolved That—

I will endeavor to be kind at all times, both to mankind and animals.

I will be courteous and considerate to the aged, realizing that the burden of their years makes the lightest burden seem heavy.

I will be gentle to women and little children, with due regard for their weaknesses and frailties. To the sick and afflicted I will be merciful and kind.

I will keep my troubles and heartaches to myself, so that other hearts will not be burdened by the weight of my misfortunes.

I will endeavor at all times to be cheerful, and smile, so that my smile may be an incentive for others to smile. I will endeavor to be unselfish, not striving for more than what is mine in all fairness, and realizing that others have rights and deserve consideration.

I will earnestly try to avoid saying unkind things to people and about them, realizing that slander is a blow from behind, and the act of a coward, and I know that kind words have eternal life. In short, I will try to make this sad old world less sad, because I will never pass this way again. Every influence, ignoble or unkind, goes out from me like the vapor from the bottle and can never be recalled. This is my resolve, and may the Power that rules the world keep me steadfast.

Does God Help Men?

BROTHERHOOD is the slogan of the twentieth century. Man is a dependent being. So God set the solitary in families and ever since men have organized into the clan, tribe and nation to help one another. Our towns and cities are honey-combed with fraternities. But the strongest men have sought more than human help—Washington prayed in the winter forests while his shattered army was starving and freezing at Valley Forge, Lincoln was "driven to his knees" because he had nowhere else to go. Does God answer man's cry?

There is a beautiful reply in the song of Moses. It is the graphic scene of the eagle teaching her young. As an eagle stirreth up her nest, fluttereth over her young, spreadeth abroad her wings, taketh them, beareth them upon her wings, so God taught the great captain of Israel. No doubt the young eagles would prefer to remain in the soft, warm nest and be fed, but the mother bird will not have it so. She understands that they would never gain strength to find food for themselves or know the glory of soaring far up into the eye of the sun. So she tumbles them out of the nest—she brings thorns and sticks them in the sides of the nest—and when the eaglets are out she hovers above them as if to encourage them to fly, and after they have tried their own feeble wings and are exhausted and ready to fall, with one swift circle she swoops beneath them and bears them up on her pinions. Thus God led Moses.

So God helps every one. He first allows us to try for ourselves. He brings discomforts into our lives; He tumbles us out of the easy places. As Brown- ing has it, He

"Turns earth's smoothness rough"

that we may develop all possible strength in ourselves. God never does for us what we can do. When the resolute man meets a difficulty or obstacle his impulse is to resist and "face it plump" and in this resistance he acquires strength, like an athlete punching a big leather ball in the gymnasium to toughen his arm. Then when we have fought as hard as we could and have done our best and are ready to drop weary and disheartened by the roadside, the Almighty Father comes, as we call for Him, and places beneath us the everlasting arms and bears us up. They that wait upon the Lord shall renew their strength, they shall mount with wings as eagles, they shall run and not be weary and—what is harder than all else—they shall patiently walk and not faint.

REV. CHARLES F. WEEDEN.

Kind Words

IF ANY little word of mine
May make a life the brighter,
If any little song of mine
May make a heart the lighter,
God help me speak the little word
And take my bit of singing
And drop it in some lonely vale
To set the echoes ringing.

If any little love of mine
May make a life the sweeter,
If any little care of mine
May make a friend's the fleetier,
If any little lift may ease
The burden of another,
God give me love and care and strength
To help my toiling brother.

Look Pleasant

WE CANNOT, of course, all be handsome,
And it's hard for us all to be good.
We are sure now and then to be lonely,
And we don't always do as we should.
To be patient is not always easy,
To be cheerful is much harder still,
But at least we can always be pleasant,
If we make up our minds that we will.

And it pays every time to be kindly,
Although you feel worried and blue;
If you smile at the world and look cheerful,
The world will soon smile back at you.
So try to brace up and look pleasant,
No matter how low you are down,
Good humor is always contagious,
But you banish your friends when you frown.

* * * * *

The inner side of every cloud
Is bright and shining,
I therefore turn my clouds about,
And always wear them inside out,
To show the lining.

The Overland The King of Cars

No other car has so large a sale—none has made such amazing records. Price, \$1,000 up.

It requires four factories employing 4,000 men—turning out 140 Overlands daily—to meet the flood-like demand for these cars. Yet two years ago a hundred rivals had a larger sale.

The reason lies largely in the car's utter simplicity. Its able designer made it almost trouble-proof.

He created an engine which, for endurance, is the marvel of engineering.

He designed the pedal control. One goes forward or backward, slow or fast, by merely pushing pedals. The hands have nothing to do but steer.

A child can master the car in ten minutes. A novice can drive it a thousand miles without any thought of trouble.

The Overland always keeps going, and almost cares for itself. All the usual complexities have been eliminated.

That is why each car sells others, and our orders for this year's Overlands amount to \$24,000,000.

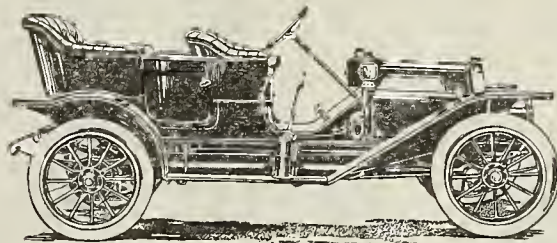

\$1,000 to \$1,500.—According to size, style and power

Another fact is that no other car gives nearly so much for the money. This is due to our enormous output, and the fortunes invested in our automatic machinery. It would bankrupt a smaller maker to try to compete with us.

You can get a 25-horsepower Overland, with a 102-inch wheel base, for \$1,000. You can get a 40-horsepower Overland, with a 112-inch wheel base, for \$1,250. The prices include lamps and magneto.

This car, which has captured the country, is the car you will want when you know it.

Two Free Books

Nothing is published about automobiles so interesting as the facts about Overlands. They are told in two books which we want to send you. Every motor car lover should have them. Cut out this coupon as a reminder to write for the books today.

The Willys-Overland Co.
Toledo, Ohio

Licensed Under Selden Patent
Please send me the two books free.

OREGON WANTS YOU

In the Willamette valley—Oregon's garden of sunshine and fertile soil—the climate is fine. Irrigation not necessary. Fruit lands finest in Oregon; garden and general farm products best in the world. Demand for these products far ahead of supply and top notch prices guaranteed. Excellent steam, electric and water transportation. Oregon needs you. Come.

Tell us about what you want—number of acres, for what purpose, etc., and we will send literature and general information. We are the largest operators in the Northwest and have splendid opportunities for you. Our reference is any bank or mercantile institution in Portland.

THE JACOBS-STINE CO.

142 Fifth Street Portland, Oregon

When Were You Born?

Would you like to have your birthstone and the appropriate flower of the month in which you were born on a post-card? You can get them without one cent of expense.

THESE twelve beautiful post-cards, one for every month, have pictured on each one the stone or jewel that should be worn by persons born in that month. The post-card also tells what the jewel signifies.

Send To-day for Them

We will send you these beautiful post-cards without cost, if you will send us 10c (silver or stamps) for a three-month subscription to Farm and Fireside. Our only requirement is that the subscription must be for some one who is not now a regular subscriber. Make sure to get these birthstone post-cards and write today. Address

FARM AND FIRESIDE, Springfield, Ohio

Here's Good News on My 1910 Split Hickory Buggies

We have the largest exclusive vehicle and harness factory in the world. We buy all high-grade materials in enormous quantities—making tremendous savings. You share in these savings because we sell direct to you at factory price. That's why we save you 25% on any Split Hickory Vehicle you want—from our 125 styles.

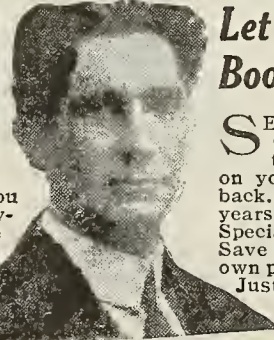

H. C. Phelps
Manufacturer of
Split Hickory Vehicles

Let Me Pay Postage on My Big, New Book of 125 Styles to Your Home

SEND me your name now. I'll send you my book. Choose the Split Hickory you want. I'll guarantee to save you 25% on the retail price. Try it 30 days on your own roads. If it isn't all you expect—send it back. If you want to keep it—I'll guarantee it for 2 full years. If you decide to take my Split Hickory Auto-Seat Special—I'll save you \$26.50. Buy direct from the factory. Save the in-between profits. Keep them at home in your own pockets.

Just write me now—a postal. Know my offers before you buy. Just a penny to find out how to save 25% on the buggy you want. Write me.

The Ohio Carriage
Manufacturing Co.
Station 23, Columbus, O.

Save
\$26.50
Cash

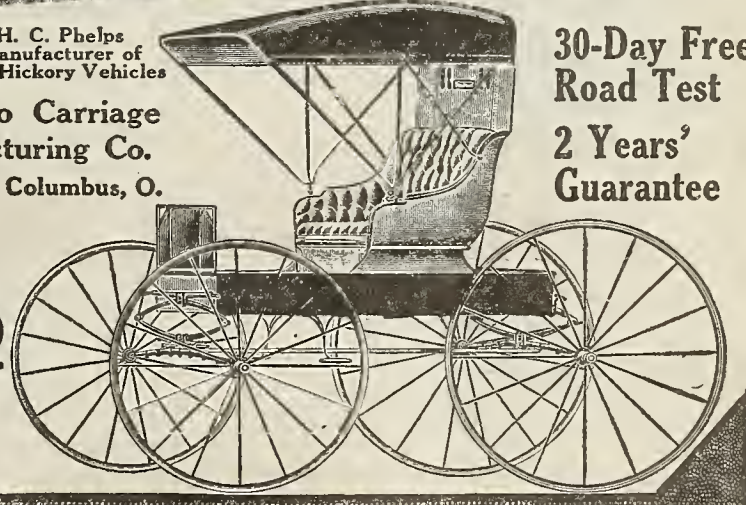

30-Day Free
Road Test
2 Years'
Guarantee

The BEST CREAM SEPARATOR

That's What the
WORLD'S STANDARD
DE LAVAL

Has Been From the Very Beginning of Cream Separators 32 Years Ago

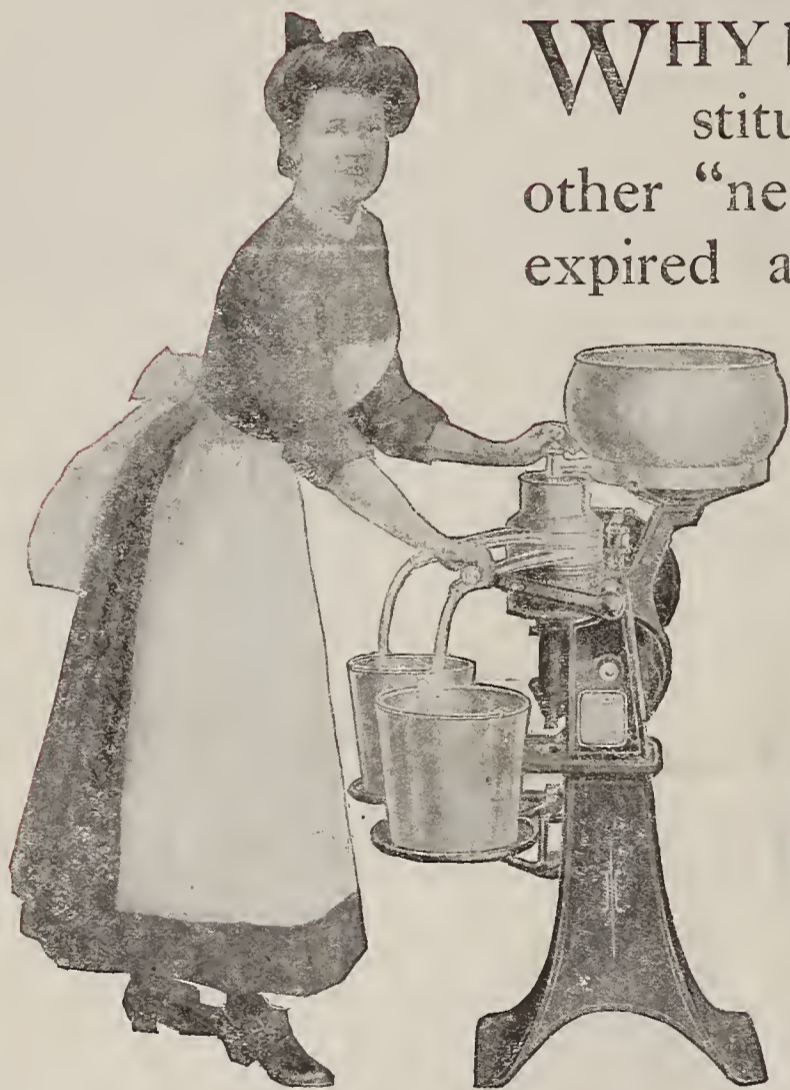

WHY bother with "copies," "imitations," "substitutes," "equivalents," "just-as-goods" and other "near" separators, that merely utilize the expired and cast-off DE LAVAL inventions and types of construction of from ten to twenty and thirty years ago?

There is no other cream separator made that comes within ten years of the IMPROVED DE LAVAL of today.

See, Compare and Try

a 1910 DE LAVAL for yourself beside any other separator made and you cannot help so decide.

That is what any DE LAVAL agent will be glad to help you to do. It will cost you nothing and may save you a great deal. You have but to ask for his name and address if you don't know it.

THE DE LAVAL SEPARATOR CO.

165-167 BROADWAY
NEW YORK
173-177 WILLIAM STREET
MONTREAL

42 E. MADISON STREET
CHICAGO
14 & 16 PRINCESS STREET
WINNIPEG

DRUMM & SACRAMENTO STS.
SAN FRANCISCO
1010 WESTERN AVENUE
SEATTLE

EASTERN EDITION

FARM AND FIRESIDE

THE NATIONAL FARM PAPER



ESTABLISHED
1877

APRIL 25
1910



Surprise Package

of 20 Beautiful Post-Cards

For Every Reader

The choicest assortment of delightful cards. Birthday, Best Wishes, Good Luck, Congratulations. Any time you need a postal you find one that just exactly suits. Every lover of beautiful post-cards will want our surprise collection of 20 cards. Every card is printed in 12 colors. Every card is an art masterpiece and they are all different.

Without Cost

FARM AND FIRESIDE has been able to obtain the choicest collection of post-cards ever made by the most celebrated makers of post-cards in America. By buying a large number of sets of these exquisite cards, we are able to offer them to FARM AND FIRESIDE readers absolutely without charge, as explained below. Never before has FARM AND FIRESIDE made such an offer to its readers. We make this offer now because we want to obtain a few more good readers for FARM AND FIRESIDE in your neighborhood.

A Choice Collection

FARM AND FIRESIDE's surprise package of 20 post-cards contains the choicest assortment of delightful cards—birthstone cards, showing the precious stone and the flower appropriate to people born in each of the 12 months; friendship cards, each one picturing a beautiful flower and an appropriate verse. Besides these, there are many more beautiful and artistic post-cards. This set of 20 cards comprises the most popular and beautiful post-cards of sentiment ever brought together.

How to Get the Cards

We will send you this surprise collection absolutely without cost to you if you will send us 25 cents for one new 8-month subscription to FARM AND FIRESIDE. The subscription must be from some one who does not now get FARM AND FIRESIDE.

Tear off the coupon below. First write your own address, and then the name and address of the new subscriber, and send to us with 25 cents. In return, we will send you the surprise package of 20 post-cards, postage prepaid by FARM AND FIRESIDE.

FARM AND FIRESIDE guarantees that you will be delighted with the post-cards.



FARM AND FIRESIDE, Springfield, Ohio.

Please send me at once the surprise package of 20 post-cards above. I inclose twenty-five cents for a new 8-month subscription to FARM AND FIRESIDE.

Your Name

Address

New Subscriber

Address

F F 4-25-10.

Agricultural College Reports on Paints



PROF. E. F. LADD, of the North Dakota Agricultural College, has surprised, not only the general public, but the manufacturers of honest paint materials themselves, with his discoveries of the extent and boldness of the paint frauds sometimes perpetrated. Water is used for linseed oil and charged for at oil prices. Chalk and various ground rocks and earths are made to simulate white lead and charged for at white lead prices.

¶ No wonder many paint jobs go wrong! The property-owner's only protection is to buy his white lead and linseed oil separately and have them mixed into paint on his premises. This made-to-order paint is safe. It gives a dollar's worth of protection for the dollar expended.

¶ We guarantee our white lead absolutely pure. The "Dutch Boy Painter" is the mark to look for. Pure linseed oil can also be had. If you are in doubt write us and we will give the name of a reliable brand.

¶ We have some very valuable booklets on painting and decoration—the latest ideas—free to those interested. Ask for "Dutch Boy Paint Adviser No. 47."

Our Pure White Lead ("Dutch Boy Painter" trade mark) is now packed in steel kegs, dark gun-metal finish, instead of in oak kegs as heretofore. Ask your dealer.

NATIONAL LEAD COMPANY

An office in each of the following cities:

New York Boston Buffalo Cincinnati Cleveland Chicago St. Louis
(John T. Lewis & Bros. Co., Philadelphia)
(National Lead & Oil Company, Pittsburgh)

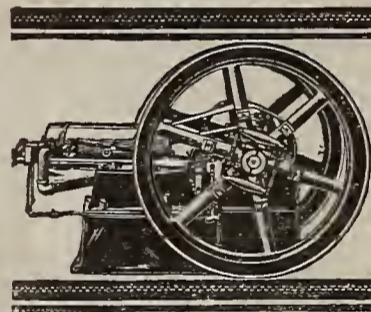

WHY YOUR ENGINE IS IN THE IHC LINE

YOU want the simplest, most economical, most reliable and most durable engine made. You want the one that saves the most work, time and money. In short, you want the engine that pays the biggest dividends. That is why your engine is in the IHC line.

After carefully investigating other engines, thousands have chosen from the IHC line. They now know what perfect power-service means, for IHC engines are unequalled for running the many machines on the farm—such as cream separator, wood saw, feed cutter, churn, grindstone, fanning mill, corn sheller, thresher, shredder, pump, etc.

Wherever you go—IHC engines are giving satisfactory service. Judge by what they are doing for thousands. Judge by comparison—point by point—with other engines. To be absolutely sure of getting the engine that will mean most to you—choose out of the line of

IHC Gasoline Engines

A Size and Style To Suit Every Need

You will get the engine that is best adapted to your work. You will get the engine that will work simplest, cheapest and best. You will get a simple engine that you can depend on. IHC engines are made in many sizes and styles. Whichever one you choose—is best in its class.

IHC Vertical engines are made in 2, 3 and 25-horsepower; IHC Horizontal engines (portable and stationary) are made in 4, 6, 8, 10, 12, 15, 20 and 25-horsepower; Famous air-cooled engines are made in 1, 2 and 3-horsepower; Hopper cooled engines are made in 2, 2½, 3, 4, 6 and 8-horsepower; and there are also IHC sawing, spraying and pumping outfits—besides the International tractors—successful in every contest, winning the highest honors at home and abroad—made in 12, 15 and 20-horsepower sizes.

See the local International dealer at once. Let him tell you all about the IHC engine that meets your needs exactly. You will be well repaid for your visit. If you prefer, write direct to us about the engines you are most interested in and we will promptly send you catalogues and any special information you request.

INTERNATIONAL HARVESTER COMPANY OF AMERICA
(Incorporated)
CHICAGO U S A

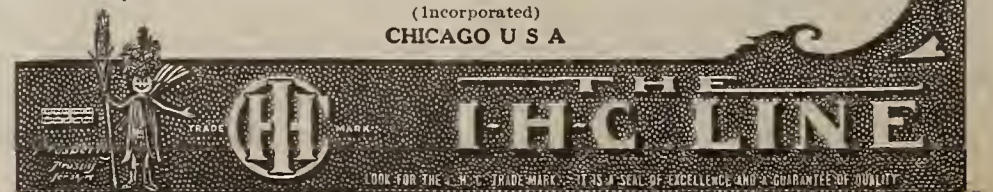

FARM AND FIRESIDE

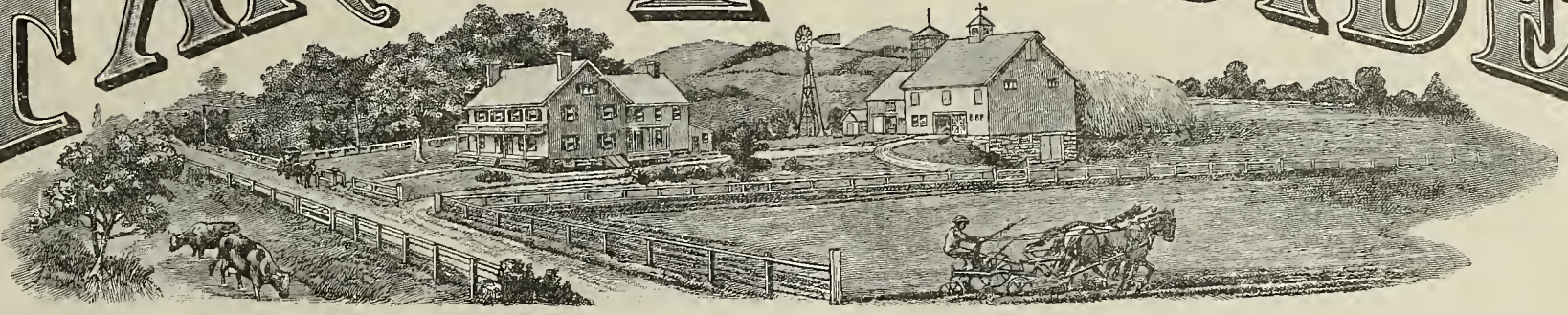

Vol. XXXIII. No. 14

Springfield, Ohio, April 25, 1910

PUBLISHED SEMI-MONTHLY

Doubling the Yield of Our National Crop

Every Farmer Can Breed Better Corn—By Prof. R. A. Moore

Professor Moore is head of the agronomy department of the University of Wisconsin. It has been under his inspiration and leadership that the Experiment Association of that state have doubled the average corn yields of their farms. Their success is only a sample of what farmers are attaining everywhere by working along the lines here sketched. In the words of a celebrated advertisement "Others have done it—why not you?" EDITOR.

NO SINGLE farm crop admits of such great improvement at the present time as our national crop, corn. When we consider that in money value the corn crop of the United States more than equals all other cereals combined, we can then appreciate what it would mean to the farmers even to increase the yield four or five bushels per acre. In Wisconsin, where special stress has been put upon corn improvement during the past eight years, we have found it possible to nearly double the yield. A test in which six hundred and three members of the Wisconsin Experiment Association took part and which ran through a course of five years (1905-1909, inclusive) show an average yield of the Wisconsin No. 7 corn of sixty bushels per acre, which was ten and a half bushels of shelled corn above that of the best variety compared with it. The average yield for the state in accordance with government statistics during the same period was thirty-five bushels per acre and the average yield of the United States was twenty-seven bushels per acre.

The Silver King corn (Wisconsin No. 7) has become known far and near throughout Wisconsin for its high yield and neighboring states have been purchasing the seed extensively during the past three years. On the station farm, the season of 1908, a yield of ninety-three and six tenths bushels of shelled corn per acre was secured and several members of the Experiment Association reported yields of from ninety-five to one hundred bushels per acre. For eight years Wisconsin has been at work breeding varieties of corn especially for Wisconsin conditions until we now have six varieties which are being grown and disseminated in cooperation with the Experiment Association, an organization of sixteen hundred former students of the college of agriculture. These young men while at the college became familiar with the corn work and were furnished the pure-bred seed to start what are known as corn centers. The farmers of the state are now able to secure seed properly cured and acclimated by applying directly to the members of the association growing corn in their respective localities. In this way the select and pedigree seed grains are widely disseminated. In 1909 no less than one fourth of the entire corn crop of the state was one variety, the Silver King.

Members of the association furnish seed-corn in the ear, the only reliable way of getting good corn. By this method a farmer can tell whether or not he has corn of one breed and is enabled to cast out any ears that may be deficient in any particular.

If it is possible to increase the yield of corn from ten to thirty bushels per acre, we should all be made aware of that fact in the shortest possible time, for it makes a great difference to the farmer who is on high-priced land whether he is growing thirty-five bushels of corn per acre or sixty. It is possible. The methods which have been used by the Experiment Association and by good corn breeders everywhere can be applied by any farmer on his own place, to his lasting profit.

A large portion of the advanced yield of corn in Wisconsin has been brought about by using definite select breeds of kiln-dried seed that has high energy and vitality. Better culture has, of course, contributed to the result, but the great factor has been the use of seed from corn carefully selected, cured and tested.

We now have six standard varieties of corn for Wisconsin, and these standard varieties have been so widely disseminated that in the near future seed-corn growers located in practically every county of Wisconsin will be able to supply the farmers with select seed that has become properly acclimated to the environment of the particular locality in which it is to be used.

We cannot emphasize too much the importance of having seed-corn grown in close proximity to where it is to be used. It usually takes several years continual growing before a corn becomes thoroughly acclimated to the surrounding environment of soil and climate, and if a radical change is made, the corn will deteriorate. As far as possible, every farmer, after getting started with highly-bred seed, should grow

and husked. The ears that are not uniform in character are rejected and only those that show good type are saved for the second year's work. These ears should be thoroughly cured and put away where mice will not molest them or where they will not be subject to frequent variation in temperature.

The second step in corn breeding is known as the ear-to-the-row method of breeding. For this we use the ears selected the previous year. The ears are tested for germination and only the strongly germinating ears kept. Of these the butts and tips are rejected and the middle two thirds of the ear is generally used.

Ground should be selected upon which similar crops have been grown from year to year so that the soil will be in a uniform condition. Each ear is planted in a separate row, until fifty or one hundred ears are used. The hills are an equal distance apart and the same number of kernels, usually three, are planted to the hill.

The outcome is astonishing. Some of the ears of corn planted have the energy, vitality and projected efficiency to produce as much as ten times the amount of select seed-corn that other sister ears are able to produce. There are factors that make up an ear of corn that are not visible to the naked eye, and the only way we have of testing its general worth is by putting it to the growing test. The rows that are to be the heavy yielders of good seed-corn early become noticeable for their general uniformity which they hold throughout the entire row.

The next year's seed-corn should be secured from these high-yielding rows, and it will transmit this special function of yield and perfection of ears to its progeny of the next year's crop.

By this method of breeding, some of the silks on the high-yielding rows will be fertilized by pollen of the low-yielding rows, but by running an ear-to-the-row plot each successive year, planted from the seed of the high-yielding rows, the tendency is soon to eliminate any damage that has been done by the first injurious crossing.

In some instances every alternate row is detasseled so as to prevent close fertilization and the seed-corn selected then from the detasseled rows.

Each and every farmer should have a select seed patch of two or three acres planted of the same variety as that of his general field and grow in connection thereto. This seed patch should be planted in accordance with the ear-to-the-row method, as above described. By selecting the seed from the high-yielding rows, great advancement can be made in the way of securing seed of a much higher yielding efficiency.

Good seed-corn does not, of course, guarantee good crops. Poor soil poorly cared for will give a poor crop no matter how good the seed is; but using good seed you are sure good care will not be wasted, by the failure of the seed in germinating or breeding power.

While the rotation of crops and proper planting and culture go hand in hand with breeding in securing large yields of corn, yet, with these essentials well attended to, if we plant scrub stock low in vitality we get poorer corn each year, until finally we are forced to change seed after suffering great loss.

Tending a seed-breeding plot takes time, but counting the sure and increasing yields as wages, it is time well paid for. The ear-to-the-row breeding plan is distinctively a farmer's method. The farmer's object is to produce the largest possible yield per acre. The ear-to-the-row plot singles out the heavy-producing ears, which pass that characteristic on to their offspring.

For this country to double its average yield is a theoretical possibility not so very far-fetched. For many a farmer to double the yield of his own place is a present, practical possibility. He has the means ready to his hand.

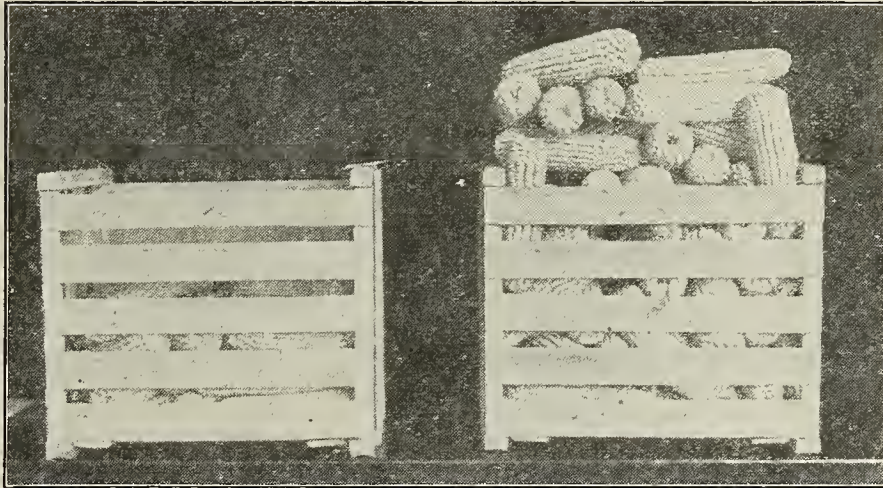

Ear-to-the-Row Corn Breeding. Crate on Left, Row Eighteen, Twenty-Nine Pounds of Good Seed-Corn; Crate on Right, Row Eleven, Sixty-Two Pounds. The Two Ears From Which These Rows Were Planted Looked Equally Good

and develop his own seed from year to year. By following this practice his corn becomes more acclimated to his special conditions, while at the same time, by the practice of rigid selection, it becomes better from year to year.

How can he bring this improvement to pass? His first efforts should be toward selecting for an ideal corn-plant. He should have in his mind those special characteristics he desires to perpetuate. Such ideal corn-plants are to be found in his general field. Their selection is the first step in corn breeding.

In order to do this well the farmer should go through the field, following definite rows, at a time when the plant will show its general characteristics to the best possible advantage. This is usually when the corn is in the milk, as then the leaf, ear and stalk can be studied to good advantage. We should select a medium stalk which puts out one good ear about three feet above the ground. The stalk should have numerous broad healthy leaves. The leaves reflect the character of the corn and should be made the subject of careful study.

When the ideal stalk is found it should be marked so as to recognize the plant after the corn has ripened. After the first plant is found, other plants are selected that conform closely to the first selected stalk. In this way two or three hundred stalks are marked and after the corn is well ripened the ears from them are picked



The Difference Between Ordinary Scrub Corn and the Well-Bred Silver King (Wisconsin No. 7)

The Eye-Tooth and What Came of It

By L. L. Klinefelter — Illustrated by Fred E. Lewis

OF ALL the days of the year there is none that comes back more distinctly to an old man than the old-fashioned "Butchering Day." I think I hear a hundred gray-headed readers of FARM AND FIRSIDES say, "I believe that's so, but I hadn't thought of it before." This may be due to the fact, for it is a fact, that the very name of "Butchering Day," with its attendant suggestion of slaughter, has a forbidding effect which has caused gentle minds, like yours and mine, beloved, to avoid the thought of it.

However, when we come to think it all over, we find it difficult to see just why the slaughter of a thousand men on the field of battle should stir the poet to write an epic, while the slaughter of a dozen pigs produces literary nausea.

It can hardly be the mere fact of slaughter, since both are slaughter. We have been told so often that to kill an enemy in battle is a glorious thing to do, that we forget the killing and think only of the glory. On the other hand, we have been taught, also, that "the merciful man is merciful to his beast," and we do not look upon the infliction of pain with pleasurable emotions. Perhaps, if we saw the thousand men who fall in battle, writhing in their death agonies, we might be less charmed by the epic of the past.

It may be that we are able to glory in the death of the thousand because we do not see them die, and are shocked by the death of the pig which takes place before our eyes. Who can tell?

Religious teaching has much to do with this, too.

The Doukhorob of western Canada will not eat meat, because he holds life too sacred.

He will refuse pie if lard has been used in the crust, but convince him that it was shortened with Cottolene, and pie "goes" with the Doukhorob.

The Jew eschews pork, but chews beef like the rest of us.

In a Jewish quarter of New York a teacher in the public schools adopted the old-time plan of punishing pupils who used bad language by washing out their mouths with soap. The parents arose in rebellion, because lard is used in soap-making and it was sin for any form of pork to enter the mouth. But the school-ma'am, wise above her generation, proved that she had used soap made of cotton-seed oil, and peace reigned once more in the Ghetto.

The Hindoo believes in the transmigration of the soul and refuses to eat meat for fear he may devour a deceased relative.

The Sepoy rebellion, one of England's hardest wars, broke out because the Sepoy soldier was required to bite off the end of cartridges greased with tallow.

And who can blame the Sepoy for rebelling? How could he know that in biting off the tallow-soaked paper of the cartridge he might not be biting off his grandfather's nose!

The discussion of Butchering Day is leading us far afield, isn't it?

It branches out into literature, history, religion and science.

I nearly forgot the science, but I just happened to think of our eye-teeth.

And what have our eye-teeth to do with Butchering Day, you ask.

A great deal. Perhaps they furnish us with our only rational excuse for the destruction of life which it implies.

The eye-tooth is the remnant of the fang and proves our kinship with the beasts that prey.

The fang is the hall-mark of the carnivore—the flesh-eater.

Man, having an eye-tooth, is a carnivorous animal, and Nature meant that he should eat meat.

But eating meat presupposes killing, and thus science comes to our relief and hallows Butchering Day by her august assent!

Were the Doukhorob scientific he would eat the lard-permeated pie-crust without a qualm of conscience.

Were the Jew as familiar with zoölogy as with the Talmud he would recognize the presence of lard in the soap in the anatomy of his offspring as a perfectly legitimate element in the development of moral utterance, while the

scientific Sepoy would merely thrust his tongue against his eye-tooth and content his soul with the knowledge that to bite off his grandfather's nose was a perfectly natural act and not forbidden by the doctrine of transmigration. If his grandfather had entered into a bullock, should he not expect to be bitten?

I have been trying to think how science justifies the



"Victims of the eye-tooth"

slaughter of men in battle, but cannot think of any way, since the soldier does not eat the enemy he slays, and the eye-tooth stands for killing for food only.

Possibly there is no natural justification and the poet was off his base when he wrote the epic.

At the age of ten one does not bother himself with religion, history, science or much of anything else, for that matter.

At ten one does not insist that science should hallow Butchering Day, for it is itself a holiday (and what is that after all but a hallowed day?).

Yes, my fellow-graybeards, you remember how you got up early that frosty morning and saw from the window down in the meadow the fire heating water in two big copper kettles and the big slanting hogshead partly buried in the ground.

You shivered while you dressed yourself, of course, and at any other time you would have cried out against the hardship of such early rising. But, as you shivered, you watched the ghostly figures of the men as they flickered in the firelight through the palings of the garden fence.

In your haste you got your trousers on wrong side in front and that took valuable time. Boys wore trousers fifty years ago (or perhaps they were pants, but not knee pants).

You were pulling on the last boot (boys wore boots, if they had 'em, fifty years ago) when a rifle-shot rang clear in the morning starlight and you knew you would be too late for the opening of the matinée.

And so you were, for you arrived just as four or five men were dragging a three-hundred-pound hog over the frosty sward to the barrel. But you were in time to hear the mighty splash as the great porker went head first into the scalding vat. You saw the boss butcher take him by the hind feet and wallow him about a few times until his practised hand told him to pull him out, tilt him over and souse the latter end into the barrel. Another wallowing or two and all hands grappled with the slippery ears and nose and forefeet, and drew the subject out upon the scraping-table, made of the old family sled by removing the box.

Talk about "hair-pulling." There was where they had it, and in a few minutes, with many a grunt and "heave-oh," the white carcass hung on the gibbet, head downward, like a malefactor in the days of old.

A few deft strokes of a long sharp knife and the entire department of the interior rolls out into the bushel basket.

No, not all. Only the "interls." The lights and other divisions of the interior department require special manipulation, during which the boss butcher holds the back of the long-bladed knife between his teeth and an absent look comes into his eyes, as he gropes for various important items in the budget.

But presently number one is disposed of and there is another rifle-crack and number two follows over the same route to the gallows.

By a little after sunrise the ghastly disemboweled forms of half a dozen gambrel-supported victims of the eye-tooth swing in the crisp air and all hands go in to breakfast on buckwheat-cakes and maple syrup.

Carnage and waiting for the second table combine to give you an appetite.

After breakfast the work of cutting up begins, and the boss butcher is the biggest "cut-up" in the bunch.

On the long oak benches are laid the long fat sides of the late deceased and with deft strokes here and there the boss butcher carves out oval hams and square shoulders which disappear in the pork-barrel in the cellar.

You don't go to school to-day because you convinced

mother that you needed to do a lot of things (which you never do). But you inflate miniature balloons and have a good time. Perhaps you carry straw to put under the beef when it is dressed behind the barn, but that is about all you do, except to stand around and watch the boss butcher slice off the long white ribbons of fat meat for the big kettles which have been brought around to the front of the house where a more convenient fire-place has been laid off.

And when the boss butcher tosses a kidney into the boiling water you wait until it is "done" and fish it out with the long-handled iron fork. Given a dash of salt, a stewed kidney and a boy, and you may see why Nature never quite obliterates the fang. 'Tis then the primeval eye-tooth declares its first intent.

Nowadays, in Chicago and Kansas City and Omaha—where every day is Butchering Day out in the stock-yards where the pigs are chased into the great beyond by car-load lots, with a government inspector looking on—butchering is a business, an industry, a factory process. On the farm of your boyhood and mine it was an art, and the part that came after supper—the sausage-making part—was a fine art, fit to rank with music and sculpture and painting. If you don't agree with this, it just shows you never tasted country sausage with a lot of gravy to put over the pancakes, on a cold morning.

All day long the women have been cleaning the casings. These good ladies had reputations as artists in cleanliness, and they could tell to a degree how hot the water might be without injury to the delicate fabric which later served to hold the appetizing sausages whose long festoons would next day hang from darkened beams in the smoke-house, while the pungent fumes of rich hickory smoke permeated them for a day and left a flavor envied by the gods.

But all good things must come to an end and bed-time will come, even on Butchering Day. You go to bed about eleven and your last thought is a sort of wonder how they could have got through it all without your help.

And for weeks to come your dinner-pail at school holds choice tidbits and left-overs from Butchering Day.

All Sorts of Weeds

EVERYBODY despises weeds; yet were we buying a farm we should pay a higher price for the farm that produces weeds of rankest growth, the taller and healthier the better. Why? Because if that farm is fertile enough to grow thrifty weed crops we can depend upon it that the same soil under careful culture will produce similar crops of the kind we want. When we went upon our present farm fifteen years ago, one field had been left the previous season to grow up in mustard and ragweeds higher than our shoulders. The following season we raised the best corn there that we ever had, and now scarcely a ragweed shows its head there.

It is hard to estimate all the ways in which weeds injure the farmer. They make the farm unsightly when left to run rampant in the fields. They crowd the growing corn, causing spindling stalks and small nubbins. In the potato-fields they make the harvesting of the crop laborious. The hay-field is a place where we should especially endeavor to keep them down for they not only lessen the yield of hay, but depreciate its quality for feed or sale. The seeds get into the grass-seed and the manure-pile to be sowed back upon the fields.

One kind of weed the farmer inflicts upon himself. In the corn-field we find too many stalks of corn in the hill, making more stover and not as good ears, because we planted too thick. Had we used a grader our seed-corn would have been uniform and each hill would have been planted evenly. There corn is a weed to its own crop. In the oats-field we find that grain sown too thickly in the drill rows crowds the proper growth of the plant and its development of grain. Winnowing the oats over a good fanning-mill removes the small and light grains and avoids this.

The wheat-field is full of weeds if you allow rye to spring up far above the wheat-heads. Of course you sowed it there, either last autumn or in a previous seeding. Best go through with a knife or sickle and whack off the rye tops as soon as they have sprung their heads. At least take time to cut out enough so your wheat-seed for next year will be clear of rye.

Weeds—the kind you sow and the kind that sow themselves—rob the soil of moisture, of elements of food required by other plants, steal light and space from the farm crops, harbor insect pests and cut production everywhere.

Then there is the crop of boys and girls on the farm. It is perfectly right for them to "grow like weeds" as the saying goes, but it is your fault, father and mother, if they grow up worthless, like unto the weed crop. This season, while you are giving your crops just a little extra care and culture to keep the weeds out of the hill, see if you cannot give the girls and boys sufficient care and culture to keep the noxious weeds from growing in their hearts.

GEORGE W. BROWN.



"In biting the cartridge he might be biting his grandfather's nose"



"The old-time plan of washing out their mouths with soap"



"The fang is the hall-mark of the carnivore"



"You got your trousers on wrong"

Buttermilk Cheese—A New Farm Product

Easily Made and Meets With Ready Sale—By J. L. Sammis

Here is a discovery that makes milk worth more. Twelve to fifteen pounds of cheese can be made from one hundred pounds of buttermilk, which means that twenty-five to thirty per cent of the amount of butter produced can be produced in pounds of this new cheese, on a home or commercial scale. EDITOR.

BUTTERMILK is liked as a drink by most people because of its fine flavor. Cottage cheese from skim-milk is often made on the farm and finds a ready sale among town customers.

At the Wisconsin Agricultural Experiment Station it was found recently that a superior kind of cheese can be made from buttermilk, by a process much like that used for making cottage cheese from skim-milk. Buttermilk cheese looks like cottage cheese, but its flavor is much better than that of cottage cheese, just as buttermilk tastes better than sour skim-milk. Buttermilk cheese never becomes rubbery or hard to chew, as cottage cheese sometimes does when heated too hot in making. It is not necessary to add cream to buttermilk cheese to improve its flavor, as is generally done with cottage cheese. Buttermilk cheese is easily spread on bread like butter and, when well salted, many people prefer it, especially when butter is worth thirty or forty cents a pound. On this account any one who makes buttermilk cheese can find a ready sale for it, in almost any locality.

Most farmers' wives who make butter know how important, in churning, it is to have the cream neither too hot nor too cold, but just right so that the butter will come after about half an hour's churning. On many farms this is so well understood that a thermometer is always used in churning, instead of guessing at the temperature of the cream, thus saving time and labor.

A thermometer should be used about cottage-cheese making, too, so as to have the skim-milk at about one hundred degrees, where it will sour most quickly, and to avoid getting a dry, tough curd by heating too high after the milk is curdled. In buttermilk-cheese making it is even more important to use a thermometer. Neglecting to heat up the buttermilk properly will not spoil the flavor, but it may cause some of the cheese to run through the bag and be wasted, when it is put to drain. There is no need of buying an expensive thermometer for this work. Any accurate thermometer that is so made that it can be easily cleaned will do.

The cream should be churned quite sour, if you want to make the best flavored buttermilk cheese. Collect the buttermilk from the churn in a tin pail or clean wash-boiler or any suitable vessel that can be

heated on the stove. Do not use a galvanized pail for this purpose. Do not mix any water or skim-milk with the buttermilk.

As soon as convenient, set the buttermilk over the fire and stir it briskly, so as to heat it as quickly as possible to seventy-eight degrees. Keep the thermometer bulb in the liquid when reading the temperature. As soon as the temperature reaches seventy-eight degrees, remove the pail of buttermilk from the fire and put it where it can stand undisturbed for one

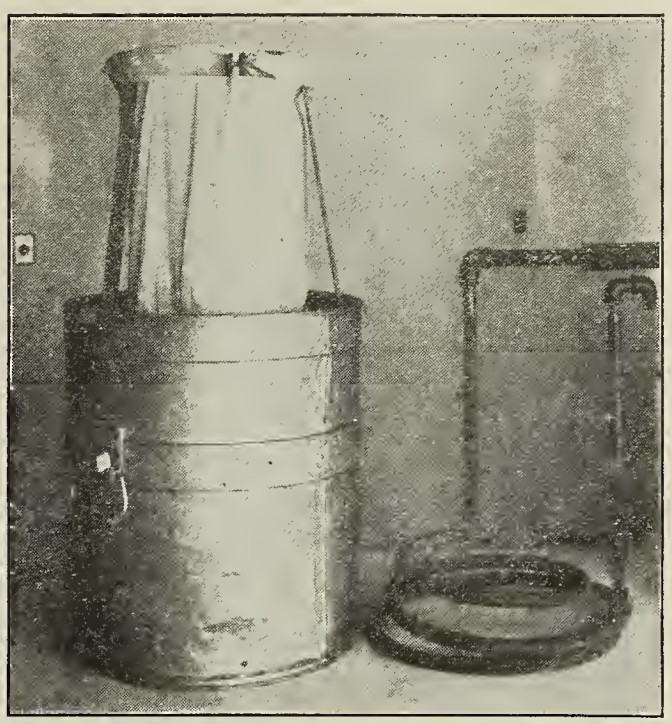

Handy Attachment for Draining Buttermilk Curd, and a Coil of Steam-Pipe for Heating Buttermilk on Large Scale

and one half or two hours, without cooling off very much. By that time the buttermilk will be fully curdled so that the clear green whey can be seen in the pail, with a large cake of floating curd.

If the cream was not very sour, the buttermilk may not be curdled so that the whey is clear, in two hours. Then the buttermilk should be left, without stirring, several hours longer at this temperature. It will final-

ly get sour enough so that the curd will separate from the whey as it should. It is better to ripen the cream well before churning.

Some farm butter-makers use an acid test, such as Farrington's Alkaline Tablets, to test the acidity of cream before churning. The same test can be applied to buttermilk. If the fresh buttermilk shows five tenths of one per cent acid or more, it will curdle properly in one and one half hours at seventy-eight degrees. If the acidity of the buttermilk is only about four tenths of one per cent, it can be curdled by heating to ninety degrees, instead of seventy-eight, or it can be left to stand at seventy-eight for several hours without stirring, as directed above, until it has ripened and curdled in a satisfactory manner. The buttermilk thus is finally changed into clear whey with a large cake of curd floating in it.

Set the vessel on the fire again as soon as convenient, stir the curd and whey gently and heat up to one hundred and thirty degrees, by the thermometer. Set the buttermilk off the fire where it will stay at about this temperature and leave it quiet for an hour to settle.

Have ready a cheese-cloth bag such as is used in draining cottage cheese. Do not stir up the curd and whey, but with a skimmer take off any floating curd and put it in the bag. Then tip the pail carefully and pour out as much clear whey as possible, without losing any of the curd. A thick layer of curd will be found at the bottom of the pail, and this curd with the remaining whey is poured into the bag. If this is carefully done, after a little experience, no curd need be wasted. After draining half a day or overnight, the curd is taken out of the bag and mixed with salt, using one ounce of salt to about five pounds of cheese. The cheese is then ready for sale. It should not be drained drier than necessary, as consumers like it rather moist, and more of it can be sold. From twelve to fifteen pounds of cheese can be made from one hundred pounds of buttermilk, and a steady demand can be found for it in almost any locality where it is put on sale.

If it is more convenient, the first heating to seventy-eight degrees can be done at noon when the stove is hot. The curdled buttermilk can then be left undisturbed till supper-time before heating it up to one hundred and thirty degrees. After supper the settled curd can be put to drain.

Where steam is available for heating, a large can or tub of buttermilk can be heated by means of a coil of half-inch or three-eighths-inch iron pipe connected by a piece of hose to the steam pipe. Such a coil, [CONCLUDED ON PAGE 6]

Growing Apples With No Worm-Holes

How Spraying Conquers the Codling-Moth—By N. T. Frame

Wormy apples are an unnecessary evil. The worms, alias larvæ of the codling-moth, can be put out of business by a simple course of spraying. Mr. Frame, speaking from his experience as an officer of the West Virginia Horticultural Society, here tells how. EDITOR.

WE HOPE we shall not be criticized as irreverent in admitting that years ago our ancestors endured bedbugs—because other folks did. Today we would not dare to have them in our house, unless we were willing to endure a local reputation as lazy or careless. The bedbug pest is a thing of the past, because experience has proved that they can be eradicated.

Wormy apples ought also soon to be a thing of the past. Even now they are to be found only in the cider-apple piles in those up-to-date apple-growing sections where orchardists have proved it practicable to grow apples without worm-holes. In some states the laws already prohibit the shipping of wormy apples. The time is rapidly coming when even the general farmer will be as ashamed to put a wormy apple in a barrel as he now is to sell milk that does not test up to the standard for butter-fat or to keep as his favorite roadster (I came near saying "car") one that takes the dust all of the way to the county fair and home again.

This worm that makes the objectionable hole in our fruit always eats his way in and generally through the blow, or calyx, end. To keep him out we must place some poison where he will eat it and die before he enters the apple. Arsenic seems to be the one poison strong enough and cheap enough to do this. The codling-moth worm is not controlled by contact insecticides like lime and sulphur or soluble oil or by fungicides like Bordeaux (made of copper sulphate and lime). Spraying with these is useless against the apple worm. But the very tiniest amount of arsenic causes him to curl up and die in short order.

The best known commercial preparation containing arsenic in convenient form is Paris green. Many fruit-growers still use it, but the great majority now depend on arsenate of lead. The threatened loss in New England of all her shade as well as fruit trees from the gipsy and brown-tail moths forced the chemists to develop an arsenic-bearing preparation which would stick to the leaves instead of washing off like Paris green; and the demands of the apple-growers of Colorado and the Northwest for an arsenate which could be used liberally without "burning" the fruit or foliage as Paris green sometimes does, hastened the rapid introduction of arsenate of lead. Now it may

be secured at leading drug and hardware stores, and all the general seed-houses catalogue it.

How much arsenate of lead to use, how often and in what manner to apply it so as to get the maximum percentage of clean fruit at a minimum of cost is a matter being warmly discussed among official experimenters and leading fruit-growers.

The general practice, in the East at least, is typically shown in the report of Professor Gossard, of Ohio, on apple spraying in 1908. First spraying, as soon as possible after the blossoms fell the entire orchard was given a heavy spraying with arsenate of lead (Bordeaux being combined in same spray for some varieties), two and a half pounds, in fifty gallons of water applied as a fine mist with a pump maintaining a pressure of one hundred to one hundred and twenty-five pounds. Second spraying, arsenate of lead was



The Trail of the Codling-Moth

again applied at same strength and in same manner about July 20th, in order to kill the second brood of worms, which were due to hatch out about that time in Ohio.

Officials of the far West, like Professors Ball, of Washington, and Melander, of Washington, have for several seasons, as the result of their experiments, argued that practically perfect results can be obtained by using one pound of arsenate of lead to fifty gallons of water applied only once during the season, just after the petals have fallen, but before the calyx cups have closed. They attribute their success to the use of

coarse spray nozzles, generally known as Bordeaux nozzles, through which the spray is driven at a pressure of two hundred pounds and more (not guessed at, but actually registered on the pressure gage of the pump) straight into the open calyxes of the blossom clusters, without reference to the spraying of the foliage.

The wonderful saving in time, labor and material of this one-spraying method has commended it to fruit-growers in all parts of the country. However, even in the Northwest the majority stick to the use of larger amounts of poison and more applications; and in the East experimenters like Professor Sanderson claim that the method will not work, that our climatic conditions are not suitable and that orchardists should not rely on one spraying—in contradiction to which are the results obtained by Professor Rumsey, of West Virginia, last year where the one-pound, one-spray, coarse-nozzle method gave practically perfect results alongside unsatisfactory results from the mist-spray method repeated twice during the summer.

A sort of a compromise between these two methods seems to have been reached by Professor Taylor, of Missouri, who gets the benefit of a thorough job at the first application by driving a coarse spray into the blossoms just as the petals fall, filling every calyx cup to the brim, following this up in ten days or two weeks, as an additional safeguard against the curculio and fungi as well as codling-moth, by a mist spray of arsenate of lead and Bordeaux, with still another mist application ten days or two weeks later. Where curculio and fungi are not threatening, the middle application may be omitted.

The accurate and rapid handling of a ten-foot bamboo rod with a nozzle on the end of it so as to drive the spray into every blossom cluster and fill every calyx cup to the brim is something of an art. The man with the biggest brains and the most accurate hands, the boss himself, will do well to practise this art until he can show the boys with accuracy and precision just what he means when he tells them to "spray thoroughly."

The results will be worth the effort. He will have the satisfaction of putting into the cellar apples that will keep because they are sound and free from worms; the satisfaction of telling his neighbors and friends that he knows that the codling-moth can be controlled; the especial satisfaction of getting from sixty-five dollars to six hundred and fifty dollars per acre more in cash money for apples free from worms than would have been received had he allowed the codling-moth in his orchard just "because folks didn't used to have to spray to grow apples."

Success in Dixie

Growing Prize Corn at a Profit—By James M. Moss

Mr. James M. Moss won the state prize for the best five acres of corn in South Carolina last year. Every corn-grower, north and south, should be interested in studying his description of the way it was done—the former for hints by which he may improve his methods by importing good things from another climate, and the latter for the things in it which he may copy. The underlying doctrine so well worked out by Mr. Moss is of universal application. EDITOR.

THE land on which this crop was grown was originally poor and sandy, and designated by the United States Soil Survey as "Norfolk Sandy Loam," the subsoil being a yellow sand, with clay underlying at a depth of from eighteen to twenty inches. By the constant application of stable manure, year after year, it had been brought up to a high state of fertility, producing previous to the test as much as two five-hundred-pound bales of cotton per acre with an application of from eight to ten dollars' worth of fertilizer.

The breaking was done with a three-horse sulky plow to a depth of about eight inches on the third and fourth of February, 1909. The rows were laid off five feet apart, and on the twenty-fourth of March there was applied four hundred and fifty pounds of dissolved bone, fourteen per cent, and fifty pounds of muriate of potash, broadcast with a one-horse distributor. Two furrows were then thrown from the lay-off furrow with a one-horse Chattanooga turn plow, leaving a ridge twelve inches wide which was thrown out deeply with a two-horse middle-burster. This furrow was then subsoiled to a further depth of eight inches with a two-horse Chattanooga subsoil plow, the soil being dry and in fine condition throughout. On April 9th a V harrow was run in this furrow, expanded sufficiently to draw in a small quantity of fertile soil, and a one-horse John Deere edge-drop corn-planter followed, planting the corn in hills seven inches apart, one grain to the hill.

The variety of corn used was the improved Garrick, which has been planted in this section for about ten years, and is noted for its fine yields. It has been accurately tested alongside of eight of

the noted varieties of the South and easily led all. In 1909 the prize one-acre field was also planted with it.

The stand secured was almost perfect, the corn being eight inches below the level and in beautiful condition for cultivation. The first cultivation was done with a one-horse Keystone weeder, running up and down the rows, one row at a time. The second cultivation was with a one-horse Syracuse harrow expanded sufficiently to clean the row with two furrows. There were four subsequent shallow cultivations. On May 27th fifteen hundred pounds per acre of the following mixture were applied on both sides of the row: Three hundred pounds of dissolved bone, fourteen per cent; five hundred pounds of kainit; five hundred pounds of fish-scrap, and two hundred pounds of cotton-seed meal. On June 14th three hundred pounds per acre of nitrate of soda was sown by hand on both sides of row, and corn laid by very little above the level.

Rains were excessive during the tasseling, silking and earing period. At one time seven inches of rain fell in two days. On June 15th a destructive hail and wind storm reduced the yield at least twenty-five per cent, as estimated by the committee of gentlemen who harvested the crop. One hundred bushels an acre was the certified yield. The financial report is as follows:

Land value \$50, interest at 6 per cent	\$ 15.00
Plowing	8.80
Harrowing55
Fertilizers	135.25
Applying fertilizers	5.35
Seed	1.25
Cultivation	6.35
Harvesting	58.75
Total expenses	\$231.30

Value of 500 bushels of corn at \$1.00	\$500.00
Stover	100.00
Total	\$600.00

Net profit, \$73.74 per acre.

While the result of this contest shows that corn-growing, even by main-force methods, may be made profitable, we do not get from it the most needful lesson for the South. We should grow as large and even larger crops on all of our acreage by much less expensive method.

In 1906 on a field of twelve acres of much poorer land I secured a yield of twelve hundred bushels at a cost in fertilizer of ten dollars per acre. This land had been planted in oats the previous year, followed with peas planted immediately after harvest. Peas were planted with a twelve-disk grain-drill, without any plowing. The grain-drill was drawn by four mules, and the land planted

in about three fourths of one day, cutting the expense of planting to a minimum. The peas were cut early, giving a yield of about one ton of choice well-dried pea-vine hay per acre. The harvest of this hay was followed by a luxuriant and vigorous second growth, which attained a height of from eight to twelve inches. This crop was turned under about eight inches deep with a three-horse Oliver sulky in November and December.

The following spring this land was harrowed deeply with a cutaway disk harrow and all subsequent preparation and cultivation was similar to that given the five acres in the above report. From this experience I concluded that while we cannot have the much-valued clover and alfalfa, the soil-renewers of other regions, we must be grateful to our beneficent Creator for another plant

which has no superior the world over, and which puts us on a parity with the most favored section. The beloved Massey of our sister state has been persistent in extolling its praises, and he can confer no greater boon upon the South than to convince her farmers of the wealth that can be extracted from our soils by its growth.

I do not want to take too much the attitude of exhortation, but I write from practical experience and the sum of my small success has been due to the lessons learned from our leading scientific agricultural writers. I am convinced that the South can never fully come into her own until her farmers adopt as their talisman these words: Diversification, Rotation and Live Stock.

Nor has there ever been a time when the average farmer should see his way so clear to the abandonment of the all-cotton plan. With fat pigs selling at ten cents a pound, live weight, at the center of pork production, mules at three hundred to three hundred and fifty dollars a head, corn at a dollar a bushel and every other article of food priced in proportion, is it not time for the Southern farmer to awake to the fact that he can grow all of these products cheaper than he can buy them? Should he not realize the fact that every acre diverted from cotton enhances the value of that product and decreases its cost of production? I am convinced that half the present cotton area can by diversification be made to yield all the world needs.

By diversification we fill our soils with the so-much-needed humus, without which we can do no successful farming, and which is as much needed for cotton as any other crop. My poor sandy land under the old system gave a yield of three hundred pounds an acre of inferior lint—to-day these lands yield six hundred pounds of choice staple to the acre. Where I found it difficult to get an average yield of twenty-five bushels of corn per acre, I now get fifty bushels. The value of diversification might be summed up thus: The more we live at home, the better are we paid for living at home. God speed the day when the intelligent yeomanry of the South shall make her what she deserves to be, the garden-spot of the world.



"The Pines"—Home of Mr. Moss

Corn Likes Home

Acclimated Seed Versus Imported Seed—By F. A. Welton

IN THESE days of corn shows and corn institutes when so much is being said from the platform and through the press to arouse interest in this "king of crops," and especially when reports of the fabulous prices paid for winning exhibits are published, there is no doubt many a good corn-grower who is earnestly asking himself the question: "Will it pay me to buy some of this high-priced prize-winning corn for seed?"

After all is said and done, we are, I think, all agreed that the ultimate aim of corn-growing is to get the greatest number of bushels of shelled corn per acre. True, a limited number of growers find it profitable to aim for beauty, but this is accomplished usually at the expense of yield, because the best show corn is often the result of extremely favorable conditions, such as strong soil, thin stand, etc., conditions which are favorable to the growth of fewer but larger ears and which usually result in a marked reduction of the total yield. The problem, therefore, in the selection of such is to secure such ears as will, under normal conditions, produce the maximum yield of shelled corn.

Unfortunately, no one has yet been endowed with the power by which to determine at sight whether an ear, when planted, will be a high or a low yielder. But we do know something about the advisability of using home-grown rather than imported seed and it is this phase of the question to which I wish to call attention in this article.

For the past few years the Ohio station has been conducting tests in which imported seed-corn was compared with that which was already acclimated. Inasmuch as the results of the several tests point uniformly in one direction, a report of one test only will be sufficient to emphasize the importance of using home-grown seed.

In 1908 three varieties—the McAuley, Boone County White and Hildreth—were obtained from Kansas, one variety—Reids—from Illinois and three varieties—Reids, Leaming and Darke County Mammoth—from southern Ohio. It should be said that all the varieties mentioned are good yielders when grown in their native localities. These varieties were grown on the station farm in one-tenth-acre plots beside a strain of Reids, a strain which had been grown on the station farm for several years and which was therefore well acclimated. The sta-

idea of the quality of the grain. The comparative dates of tasseling may be taken as a fairly accurate guide as to the comparative dates of ripening. From these it would be inferred that the Kansas varieties were from eleven to fifteen days later, the Illinois eight days and the three from southern Ohio from three to six days. As would be expected, these later-maturing varieties grew taller and consequently produced a much larger amount of stover, the excess of one variety, the Hildreth, being nearly one and one half tons per acre.

the figures in the column giving the weight per bushel of shelled corn show the quality of the corn grown from the imported seed to be inferior to that produced from the home-grown seed even after it was equally well dried out.

Similar tests conducted in various counties, tests in which typical varieties of a given county and of adjoining counties were brought together and grown in plots upon one farm in comparison with local varieties, have resulted almost universally in favor of local seed.

These facts emphasize the wisdom of going slow in the use of unacclimated seed.

Variety	Date of Tasseling	Average Height of Plants ft. in.	Stover Per Acre	Yields Based On		Per Cent Shrinkage	Weight Per Bu. Shelled Corn
				Fall Weights	Spring Weights		
McAuley, Kansas.	Aug. 7	10 — 6	5,440	78.25	56.34	28.0	47.50
Boone Co. White, Kansas	Aug. 4	10 — 6	4,700	83.40	67.98	18.5	51.50
Hildreth, Kansas.	Aug. 8	11 — 6	6,720	67.41	55.28	18.0	49.00
Reids, Illinois ...	Aug. 1	10 — 6	4,700	75.80	64.05	15.5	50.00
Reids, S. Ohio..	July 30	10 — 0	4,240	76.86	65.72	14.5	50.50
Leaming, S. Ohio.	July 27	9 — 9	3,770	80.11	69.91	12.7	52.50
Darke Co. Mammoth, S. Ohio..	July 28	9 — 10	4,167	83.26	71.00	14.7	53.50
Reids St. 84, Expt. Station..	July 24	9 — 10	3,760	86.91	77.78	10.5	54.50

tion farm is about one hundred and fifty miles north of the home of the varieties from "southern Ohio."

The corn and stover from each plot were harvested and weighed separately. In order to test the quality of the corn, fifty-pound samples of representative ears of each variety were placed in well-ventilated boxes where they were left until spring and then reweighed.

The accompanying table shows the quantity of stover and corn produced by the different varieties and gives some

The yields of grain, however, showed quite a different relation. While the home-grown variety outyielded the highest-yielding imported variety by 3.51 bushels, it led the lowest one by 19.50 bushels. These yields are based upon the weights of corn just as it came from the field at husking-time. In the spring after the corn had dried out to a uniform water content, the home-grown variety led the highest-yielding imported variety by 6.78 bushels and the lowest one by 22.50 bushels. And, furthermore,

Buttermilk Cheese—A New Farm Product

[CONTINUED FROM PAGE 5]

which can be made at home, is shown in the illustration.

One can often get buttermilk from the nearest creamery for ten or fifteen cents a hundred pounds and this can be made into buttermilk cheese worth seven to fifteen cents a pound.

The same general method of making buttermilk cheese can be used in creameries, where large quantities of buttermilk have heretofore been wasted. It can be shipped or sold in tubs to dealers, bakers or grocers, wherever cottage cheese is used. Creameries use a curd rack and cloth, instead of cheese-cloth bags, for draining the curd in large quantities. In a creamery the whey is drawn with a siphon, since the vat cannot be tipped to pour it out. The sale of cheese will often pay running expenses.

Bulletin No. 195, describing buttermilk-cheese making, will be sent to any one on request, from the Agricultural Experiment Station, Madison, Wisconsin.

Sweet Sorghum

Its Worth and Its Culture—By J. C. Mohler

IN ADAPTABILITY sorghum covers about as wide a range of conditions of soils and climate as corn, which is our most cosmopolitan crop, and sorghum succeeds in some semi-arid sections where corn often fails. On account of sorghum's notable dry-weather-resisting qualities its acreage is greatest in the states of the plains, but it is also esteemed for forage in the more humid regions, because of big yields of valuable feed, producing as a hay, when properly grown, from five to fifteen tons to the acre, depending on the soil and season, or more than can be produced by any other known crop. In Kansas it is considered the most valuable annual forage crop.

There has been considerable said, here and there, about sorghum "being hard on land." As a matter of fact, it takes no more fertility from the soil than does

to avoid as much as possible the deteriorating effects of the hot sun, dews and rains while lying in the swath. As a hay it is excellent and well worth a trial by those who are unfamiliar with it. In round numbers sorghum-hay, containing thirty-six per cent of moisture, has about eight elevenths of the feeding value of prairie-hay, containing twelve per cent of moisture. A good yield of prairie-hay is one to one and one half tons per acre, to sorghum's five to fifteen. Hence, an acre may produce four or five times as much feed when planted to sorghum as it will in prairie-grass. Compared with corn-stover and other annual forages, sorghum is the heavier producer and can be more cheaply grown.

For forage and seed the same careful preparation of the seed-bed should be given as when hay is the chief con-

them off with a hay-knife, store properly and thresh at convenience. This harvesting of the heads may be done any time after the process of curing has been thoroughly completed.

Where the producing of the seed is the chief end, and the forage is not so important, it is better to plant a smaller quantity, about three pounds to the acre, but in other ways the crop is handled as described in the foregoing. Some use a header in harvesting the seed. This is profitable and economical, and after the seed is taken off, the stock may be turned into the field to dispose of the stalks left standing. The corn-harvester, however, is preferred, for the bound forage is vastly easier to handle, and by this method a great deal of waste is saved. The corn-harvester gathers up the sorghum cleanly even when badly blown down. The make of machine should be one that throws the bundles in such a way that they will not interfere with the horses in following rounds. The difference in machines in this respect is well worthy of attention.

There is no danger whatever in feeding any kind of stock sorghum forage and hay that has been properly cured, but there is danger in the second-growth sorghum, and cattlemen generally avoid it. When sorghum is fed green, care must be exercised, for it has a tendency to produce bloat, but this is no more pronounced in sorghum than in many other common crops. As a matter of fact, cattle have been successfully pastured on both the first and second growths of sorghum without apparent harm; but as many have died very suddenly on such feeding, in other instances, suggests that it is wisdom to take no chances. Where animals are hungry and allowed for the first time to eat the plants greedily there is great danger. When they have gradually become accustomed to such pasturage, and have their stomachs pretty well filled with other forage before being turned onto the tender sorghum plants, sorghum may be successfully grazed, though the practice cannot be recommended as a general one.

In Kansas, next to alfalfa and clover, sorghum is considered the best forage crop, as it yields abundantly even on the poorer ground, is relished by stock and withstands dry weather better than any other annual plant known to our agriculture. Milo, possibly, may endure drought better, but it does not rank with sorghum at all in the forage line, being principally valued for its grain. Where hay is scarce or high-priced, sorghum is an excellent substitute or supplemental feed, and where other feeds are abundant, sorghum will add to the variety of the feed, and return sure and creditable profits.



"The common method of harvesting . . . is with a corn-binder"

a like crop of any other forage or grain. But it does take more moisture from it than most other crops—and by so doing is capable of resisting dry weather the better—so that the physical condition of the soil may be impaired and the following crop suffer if timely rains in the meantime do not saturate the soil. Of course, in regions where rains are abundant this difficulty would not come up for consideration, and in the drier portions fall plowing, after sorghum, will do much toward putting the soil in better physical condition, and the subsequent crop should not be appreciably diminished simply because it followed sorghum.

Two systems are common in growing the sweet sorghums. One is practised when a hay crop is the object, and the other when seed and forage are desired.

For hay, after the ground is plowed and thoroughly prepared, sow broadcast or in close drills, using about a bushel of seed per acre. In broadcasting, the harrow should follow, to cover the seed. Most Kansas growers think it best to sow from the fifth to the twentieth of May, or following corn-planting. They prefer varieties that mature slowly and require a full-length season, rather than early varieties, and regulate the time of sowing with a view to having the seed ripen, say, in September. Further north the Early Amber and like varieties would be suitable, for the shorter seasons, but in Kansas the Collier, a late variety, is a general favorite. Folger's and Colman are regarded as best for early and medium sorghums, respectively. Sorghum sown early and cut early is more often spoiled by rains and hot weather. May or early June sowing is probably best in all the Northern states, though sorghum has been successfully sown as late as July 4th, for hay, in Kansas, maturing ready to cut before killing frost.

In harvesting sorghum-hay, the ordinary mower and rake are used, and the sorghum put in large cocks of one thousand to two thousand pounds, well topped out, and left there until fed, usually. It should be cut when the kernels are well in the "dough," and put in the cock as soon as consistent after cutting. Perhaps a good rule to go by is as with clover, putting it up as soon as it is wilted sufficiently, the idea being

consideration. If one wishes to list, it is best to double list, or plow and then list, using perhaps ten pounds of seed per acre. If preferred, seed can be put in with a corn-planter, as it is not so easily washed out as the listed seed. Cultivate thoroughly throughout the season, as with corn. For forage and seed sorghum should be put in as a general thing right after corn-planting. Where there is plenty of rain, select the poorer, rather than the richer, soils for this crop, for on the better soils it will grow too rank and be too cumbersome in harvesting. Of course, in the drier regions this does not hold, and the better soils may be profitably employed.

The seed, having a bitter taste, is not relished by stock, but there is a ready market at from seventy cents to a dollar per bushel for it, and the yield runs from fifteen to twenty bushels per acre. Most of the Kansas-grown seed, for instance, is shipped to Texas, where sorghum is much grown in the districts where corn is not reliable. The forage remaining after the seed is off is valuable, comparing favorably with corn-fodder, and cattle are "roughed" through the winter with little or no other feed. It is preferable, though, to use it with clover or other hay, one feed of each per day. Sorghum forage is rich in sugar or carbohydrates, but contains little protein, so a balanced ration with sorghum would require concentrates rich in protein, or protein as applied in alfalfa or clover. It is usually advisable to feed the sorghum early or before, say, the middle of January, for later unfavorable weather conditions may greatly depreciate its value, although if the weather stays dry there is no danger of that. Grown for seed, it is especially valuable where corn does not reach its best development, giving as it does this excellent supply of forage, besides a money crop in the seed.

The common method of harvesting for forage and seed is with a corn-binder, letting the sheaves or bundles lie until partly cured, which requires, say, two days of ordinary fall weather, then putting up in good-sized shocks. The crop should be cut when the seed is ripe. Two men are required for cutting the heads. One of the best methods for this that has come to the attention of the writer is to take a rope and tie up the heads of the shock tightly and cut

You Need Never Paint Another Roof



There is a Roofing for your barn—that will never wear out—one that will last a hundred years.

It isn't an artificial roofing—yet the quality and durability of all artificial preparations are measured by it. It is not expensive, never dries out in Summer—never retains snow or ice in Winter—never cracks, splits, blisters, warps or cracks. It is the one roofing that never needs paint or frequent repairs—the only kind you can depend upon.

Sea Green and Purple Roofing Slate

is used wherever absolute durability—long service and satisfaction is demanded. Look around and you will find it on the roofs of the best-built homes, barns, schools, churches, private and public buildings of all kinds—not because it is cheaper, (as it is) but because it is absolutely dependable, satisfactory and will not attract lightning.

When you build or order a new roof of any kind—specify that Sea Green or Purple Slate be used and save money, all future trouble, and eliminate all fire and spark risks besides.

Send for Free Booklet "Roofs"

Containing sixteen pages of specific, practical, timely and helpful hints that will save you money in the final selection of a new roofing for any building on your farm. Simply sign and mail the coupon below and we will send your copy by return mail.

The American Sea Green Slate Co.
(Roofs that never wear out)
113 Clark Street, Granville, N. Y.

Sign and Mail This Coupon Today
The American Sea Green Slate Co.,
113 Clark Street, Granville, N. Y.

Send the Book "Roofs" and name of the nearest dealer in Roofing Slate to this address:

Name

Address

Town

Style Roof

Approximate Size

Try "The Delin"

With Your Money In Your Pocket No Deposit No Cash With Your Order

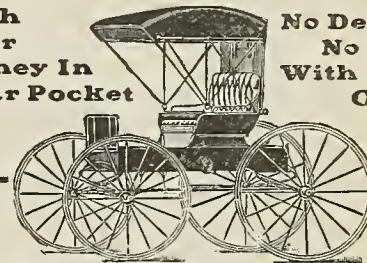

We are now selling all our buggies, runabouts, surreys, wagons, road carts, concords, phaetons and harness direct to the user at money saving, factory prices and most liberal terms ever offered: **30 DAYS APPROVAL—NO DEPOSIT—NO CASH WITH ORDER**—you pay for the goods if they are satisfactory after you thoroughly test them. You cannot get elsewhere the same high class, stylish work at the low prices and liberal terms we offer. Look into our offers before placing your order—it will pay you big. Write for **FREE** Catalog No. 20. Our **STYLES, PRICES and TERMS** will surprise and interest you.
THE DELIN CARRIAGE CO.
(Formerly The Buckeye Carriage and Harness Co.)
Central Ave. and York St. Cincinnati, O.

MAKE YOUR BICYCLE INTO A MOTORCYCLE

at small cost by attaching the **ERIE MOTOR**. This includes all parts so that anyone can make a strong, durable machine that will climb steep hills and run for 4c per mile. 1,000 in use. Sample sold at cost. Send 2c stamp today for catalog F.
Motorcycle Equipment Co., Hammondport, N. Y.

Here's Good News on My 1910 Split Hickory Buggies

Let Me Pay Postage on My Big, New Book of 125 Styles to Your Home



H. C. Phelps
Manufacturer of Split Hickory Vehicles

The Ohio Carriage Manufacturing Co.
Station 27, Columbus, O.

Save \$2650 Cash



30-Day Free Road Test
2 Years' Guarantee

SEND me your name now. I'll send you my book. Choose the Split Hickory you want. I'll guarantee to save you 25% on the retail price. Try it 30 days on your own roads. If it isn't all you expect—send it back. If you want to keep it—I'll guarantee it for 2 full years. If you decide to take my Split Hickory Auto-Seat Special—I'll save you \$26.50. Buy direct from the factory. Save the in-between profits. Keep them at home in your own pockets. Just write me now—a postal. Know my offers before you buy. Just a penny to find out how to save 25% on the buggy you want. Write me.



Get our FREE Books and Get More Profit from Your Farm

The Business Farmer doesn't sell out and buy new lands. He makes his old lands new by fertilizing.

Get our Free Books which go into the whole subject of Nitrate of Soda fertilizing and show how little it costs to get larger crops and more profits.

Nitrate of Soda

is an investment that's bound to pay. Thousands have proved it. So can you.

HAY—Nitrate of Soda, used 100 lbs. to the acre has increased the yield of barn-cured Hay 1000 lbs.

CORN—Nitrate of Soda, used 100 lbs. to the acre, will increase the yield of corn 280 pounds of grain.

ALFALFA—Nitrate of Soda is also highly successful in starting Alfalfa right.

Special directions and books on the crops you are interested in—free of charge and postpaid.

Send a post card for your book or books Today

Dr. Wm. S. Myers, Director Nitrate Propaganda
John St. and 71 Nassau St., New York

WESTERN CANADA

Prof. Shaw, Well-Known Agriculturist, Says:

"I would sooner raise cattle in Western Canada than in the corn belt of the United States. Feed is cheaper and climate better for the purpose. Your market will improve faster than your farmers will produce the supplies. Wheat can be grown up to the 60th parallel (50 miles north of the International boundary). Your vacant land will be taken at a rate beyond present conception. We have enough people in the United States alone who want homes to take up this land." Nearly

70,000 Americans will enter and make their homes in Western Canada this year.

1909 produced another large crop of wheat, oats and barley, in addition to which the cattle exports was an immense item.

Cattle raising, dairying, mixed farming and grain growing in the provinces of Manitoba, Saskatchewan and Alberta.

Adaptable soil, healthful climate, splendid schools and churches, and good railroads. For settlers' rates, descriptive literature "Last Best West," how to reach the country and other particulars, write to Sup't of Immigration, Ottawa, Can., or to the Canadian Government Agent.

H. M. Williams, 413 Gardner Bldg., Toledo, O.; J. G. Duncan, Room 30, Syracuse Savings Bank Bldg., Syracuse, N.Y.
(Use address nearest you.) (6)

ALUNDUM GRINDER

STEEL FRAME—FOOT POWER Fully Guaranteed Pat'd
With Emery Dresser, Wrench, Mower Wheel Clemp, Alundum Wheels for sharpening Mower Knives, Tools, Saws, Disks, Shears, Slaters, Etc. Alundum—the most wonderful sharpening substance known. So hard it cuts glass like a diamond, grinds ten times faster than emery without drawing temper. Price complete... \$9.50
WESTERN IMPLEMENT CO., 284 Park Street, Port Washington, Wis.



Don't let your flowers and growing plants drag on the ground. Use the

MODEL PLANT SUPPORT

to keep your tomatoes, peonies, dahlias, golden glow, chrysanthemums, etc., erect and vigorous.

PRICES
Per Dozen, \$1.75
Per 50, \$7.50 Per 100, \$12.50
Send for Price List and Catalogue of our full line of flower supports.

IGOE BROTHERS
67-71 Metropolitan Ave., Brooklyn, N. Y.

BEEKEEPING Its pleasures and profits, is the theme of that excellent and handsomely illustrated magazine, **GLEAMINGS IN BEE CULURE**. We send it for six months on trial for twenty-five cents, and also send free a 61-page book on bees and our bee supply catalog to all who name this paper. THE A. I. ROOT CO., Box 7, Medina, Ohio.

Farm for Sale

\$3,575 Income Last Year
\$1,800 from potatoes alone, widow includes machinery and tools; 80 acres in level fields, 208 acres in pasture and wood, 2,000 cords wood to sell, variety fruit; 9-room house, large barn, blacksmith shop, poultry, milk and ice houses; \$3,300, part cash is the quick sale price; picture and all details page 69. "Strout's Big New Farm Catalogue No. 30," just out, copy free. E. A. Strout Co., Station 2899 Union Bank Bldg., Pittsburgh, Pa.

YOUR BOY CAN DO AS MUCH WORK AS A MAN if he has a KRAUS PIVOT-AXLE SULKY CULTIVATOR

He simply steers it—the machine does all the work. A slight pressure of the foot moves the wheels and shovels simultaneously to the right or left at the will of the driver, while the width between gangs and depth of shovels are instantly and easily adjusted while machine is in motion.

Hillsides, Uneven Land and Crooked Rows as Easily Cultivated as Level Ground.

Simple in construction—nothing to get out of order. Made entirely of steel and malleable iron—every part interchangeable. Built for wear and work. Light draft. High or low wheels or "Pivot-gang." Also Clipper Hammock Seat.

There is just one Kraus—if your dealer does not have it accept no other—but write us. Send today for free catalog.

AKRON CULTIVATOR CO.
DEPT. 16, AKRON, OHIO

Gardening

By T. Greiner

The Radish Maggot

AN ALASKA reader tells me his troubles in raising radishes, especially the injury done by the attacks of maggots. "I tried lime, salt, sprays of various kinds and everything I could think of," he says. "The most effective remedy was boiling water poured at the root. This killed the worms without hurting the plants, although many of the plants were too far gone to save."

The radish fly is bound to make its appearance in early spring, and to lay its eggs on or near the roots of the radish-plants it happens to find, and the eggs will hatch, and the young maggots will bore into the radishes. No method of manuring, whether with stable manure, old compost or chemical fertilizers, will protect the plants. Boiling water will, of course, kill the maggots or eggs it touches, but it cannot be applied freely enough to kill those already inside the root without also killing the plant. It is not a complete nor a safe remedy.

The free application of tobacco-dust, with or without bone-meal, next to the rows of plants, will tend to keep the fly away and prevent in some measure the deposition of eggs. Many sprays, especially tobacco-tea, kerosene emulsion and probably lime-sulphur solution, will also kill the worms touched by them; but the applications should be made repeatedly at short intervals so as to catch the maggots before they find a safe retreat inside of the root. This treatment also applies to cabbages and cauliflowers for the same enemy. This year we have a new compound remedy in a combination of lime-and-sulphur solution with lead arsenate and wool fat. This looks to me promising for the various root maggots, and I am going to test its virtues. Whether it should be used for radishes, on account of the lead arsenate, except in the earliest stages of the plants' development or before they have bottomed much, is a matter of doubt. I can see nothing in the way of using it on cabbages and cauliflowers. Always try to hit the stem of the plant, letting the liquid run down to the root.

Your Own Pepper-Seeds

A Maryland reader asks whether imported or American-grown pepper-seeds are better. I grow my own, unless of some newly-introduced sort. Pepper-seed is easily grown and gathered. Why should we get imported seed? Our own gives us thrifty plants and big yields of them. That is all we require. The same thing is true of egg-plant, with the exception that it is not as easily gathered and cleaned as pepper-seed. But I manage to raise and plant egg-plant seed of my own growing, and the eggs are as big and as good as could be wished.

Weevils in Seed-Peas

A Colorado reader says he has been trying to raise his own garden-pea seeds, but they are full of weevils, so he wants me to give the particulars of the carbon bisulphid treatment. All larger drug-stores and many local ones keep carbon bisulphid, usually in cans, hermetically sealed. It should not cost more than twenty-five cents a quart, even in small quantities. It is a bad-smelling liquid, evaporates quickly if in an open vessel and the gases or fumes are heavier than air. If you will put the seed-peas, as soon as gathered and threshed, into a tight barrel or box, place a saucer with a tablespoonful of the drug on top of the peas and close the barrel or box tightly, leaving it thus for a day or two, there will not be a live weevil left, even in the very bottom of the lot, to tell the story. It is an easy task to banish the weevil from a neighborhood if every neighbor will abstain from letting old peas stand around to propagate weevils and sow only pea-seeds entirely free from weevils. If you raise your own seeds, never fail to subject them to the treatment here suggested.

Cabbage-Worm Makes Trouble

From Wyoming comes this query: "Do you know of any practical method of combating the green cabbage-worm? Could the white butterfly be attracted to and destroyed by a light after night?" No, is my reply to the latter question. The white butterfly goes out only in the day-time. It is not a night-flyer like the cutworm moth, which, I believe, could be caught and destroyed by lighted traps. But it is easy enough to protect cabbages from the green worm. Fre-

quent spraying with almost any spray material—tobacco-tea, kerosene emulsion, hot soap-suds, lime-sulphur solution, solutions of arsenical poisons, etc., will clear the worms out. The application of almost any fine dusty material, even road dust or flour, will also give relief. The best powder to apply, however, is buhach, or any other good fresh insect-powder which kills the worms on contact. But don't let your cabbage-heads be half eaten up and riddled by this voracious worm and then imagine you can repair the damage in a jiffy. Prompt action is needed on first appearance of the enemy.

Lemon Cucumber

A Kansas reader forwards to me seeds of the "lemon cucumber" and says: "I have no use for the garden lemon and vegetable peach; but I have raised the lemon cucumber for the past two seasons and like it better for slicing or eating with salt than the other varieties. When peeled and sliced, you don't find much difference, except that the lemon cucumber is more tender and more delicate in flavor." This is probably a true cucumber, not a mongrel affair like the garden lemon, vegetable orange or peach. A trial will tell the story.

Baring Out the Worms

A Portland, Michigan, reader complains that her grapes are wormy and there are webs among the clusters. I suppose this lady just has a few vines for home use and she can well afford to take a little extra pains with them. It may be too much trouble to spray the vines; in fact, it might not be necessary if the vines are not usually affected by mildew or black rot or other fungous or insect enemies. If she can have them sprayed—a neighbor might be induced to do it—all the better. But it is comparatively easy to keep the clusters free from spiders and from the grape worm without spraying. Get a lot of two-pound grocery bags. They do not cost much. Bag every good cluster of grapes. The bag is slipped over the bunch and the top twisted or pinned around the cane that holds the bunch. The clusters do not need exposure to light and air. They will develop and grow to perfection within the bags, and come out in all their bloom and glory. By all means, bag the clusters.

Wireworms and Grubs

A Danbury, Connecticut, reader asks me to give him a remedy for wireworms and grubs that are eating his potatoes. The remedy comes too late for this season. It consists of plowing the land late in the fall. The worms and grubs go into winter quarters then. Plowing breaks up their snug domiciles and exposes the worms or grubs to the tender mercies of birds and other enemies, also to the bad weather conditions. Most of the worms will come to grief in such cases. Fall plowing is an excellent practice, especially for growing potatoes, anyway. I try to have all my garden-plots plowed just before winter, and afterward, during winter, covered with manure as fast as we make it. As for the present I know of nothing much that can be done to prevent the attacks of the worms and grubs now alive in the soil.

Celery Going to Seed

From Leadville, Colorado, I have the following: "What causes celery to go to seed instead of making nice stalks for the table? I raised my plants in hot-bed, our seasons being short, and almost every plant I set out ran up to seed." I start my plants under glass late in February and through March, and transfer them to nursery rows in open ground in April or early May. In May or June the plants are set out in the rows where they are expected to make the crop. Last year I did not have more than one plant in a thousand go to seed. In other years, especially when I sowed the seed extra early (early in February), I have had a large percentage of plants of some varieties go to seed. White Plume seems more given to this disagreeable habit than other sorts. Chicago Giant has been entirely free from it thus far. Don't get discouraged. Try another variety or strain of seed. Sometimes celery will act badly one year, go to seed or be attacked by blight, etc., and another year give a good crop free from any of these troubles.

SEEDS.

3 Pkts. FREE.
Park's New Everblooming Petunias. Finest known. A glorious, fragrant bed, 20 feet across, lovely shades and markings, the envy of your neighbors. Free.

- 1 Dark Purple, Rose, Carmine, Crimson.
- 2 Fancy Striped, Eyed, Veined, Spot'd, Star'd.
- 3 Edging Dwarf White, Spangled, Throated.

5 Fine Gloxinias, 5 colors, 25c
7 Dble Begonias, 7 colors, 25c

My Flower Friend, write me a letter (not postal) and I'll send these Grand Petunias (Worth 50c) and culture, with Guide—all about flowers, packed with good things, nearly 1000 plain and colored engravings. I want to know you. Will you not write me today?

And When Writing Why Not Enclose 10 Cents for year's trial of Park's Floral Magazine, just what you need to help cheer and brighten your home. The **Oldest** and **Best** floral monthly in the world, and a welcome visitor in over 500,000 homes. Why not in yours? With it I'll send **Park's Surprise Seed Package, 1000 Sorts**, for a big bed that will delight you with flowers new and rare every morning the entire season. Money back if not pleased. Club of three 25 cts. Club with friends.

Address **GEO. W. PARK, Box 39, La Park, Pa.**
Magazine and 10 pkts choicest Flower Seeds 15 cts.
Magazine and 10 pkts choicest Vegetable Seeds 15 cts.
Magazine and 20 pkts. enough for both gardens 25 cts.

GARDENER'S FRIEND

Handy Cultivator and Weeder

80 Inches of Cutting Edge
Protects Young Plants
Saves two-thirds of your garden work! One man can do the work of three. Boy can do two men's work. It draws—no chopping, back-straining, hoeing work. Thirty inches of cutting edge—five times that of a hoe.

Adjustable and reversible—will make planting rows and cover them. Has shield to protect young plants. Only one-sixth the price of wheel hoe, yet works in loose, sandy, uneven and littered ground where wheel hoe fails. Every one absolutely guaranteed. Only \$1.50. We pay express. Try one and be convinced. Thousands have done so. Write at once. Also ask for free book and testimonials.

A Snap for Agents Liberal terms to agents if you make big money. One man made \$18.50 in one day. Article sells itself. Use sample. We need to lay in big stock. Write today for particulars. This offer limited. **ULRICH MFG. CO., 132 River St., ROCK FALLS, ILL.**

Always Successful BLIZZARD Ensilage Cutter

Cuts any feed dry or green and elevates any height. No waste power. Can't strain. Has the only knives adjustable while running. Self feed. Mounted or unmounted. Every machine tested and GUARANTEED. A labor-saver and money-maker. Ask for free book, "WHY BILLAGE PAYS."

Write for New Catalogue Free

Jos. Dick Mfg. Co.
1444 W. Tuscarawas St.
Canton, Ohio

Storekeepers who are interested in MAKING BIG MONEY

by getting their customers to read Farm papers should write us to-day. Profitable and helps the rest of your business.

The Crowell Publishing Company
11 East 24th Street, New York City

SPRAY FRUITS AND FIELD CROPS

and do whitewashing in most efficient, economical, rapid way. Satisfaction guaranteed if you use BROWN'S

HAND OR POWER Auto-Sprays

No. 1, shown here, is fitted with Auto-Pop Nozzle—does work of 3 ordinary sprayers. Endorsed by Experiment Stations and 500,000 others. 40 styles, sizes and prices in our FREE BOOK—also valuable spraying guide. Write postal now.

THE E. C. BROWN COMPANY
18 Jay St., Rochester, N. Y.

Monarch Hydraulic Cider Press

Great strength and capacity; all sizes; also gasoline engines, steam engines, sawmills, threshers. Catalog free.

Monarch Machinery Co., 603 Cortlandt Bldg., New York

CAN Your Fruit and Vegetables

AND MAKE BIG MONEY

Our Free Book tells how. Write for prices on Our Gold Medal Canning Outfits

Family to Factory sizes, \$5.00 and up. Best that experience and skilled labor can produce. Most complete machine for the money. Send for price-list or Cans, Labels and Supplies before placing your order. Our Cans are guaranteed against leaks, cleanest made and have no equal. **AGENTS WANTED.**

Robinson Can Co., Dept. 23, Baltimore, Md.

Binder Twine 7½ lb.

Fully guaranteed. Farmer Agents wanted. For samples and catalogue write

THEO. BURT & SONS, MELROSE, OHIO

POTATOES—Dovee, Carman, Cobler, Coin, Giant, Hustler, Ohio, Jewel, King, Mountain, Murphy, Queen, Quick, Reliance, Rose, Longfellow, Six-Weeks, Wonder, 85 kinds. C. W. Ford, Fishers, N. Y.

FREE 200-PAGE BOOK ABOUT MINNESOTA
Compiled by the state, describing industries, crops, live stock, property values, schools, churches and towns of each county, and Minnesota's splendid opportunities for any man. Sent free by State Board of Immigration, Dept. G, State Capitol, St. Paul, Minnesota.

SAVE MONEY ON ROOFING

\$1.00 buys full roll (108 sq. ft.) of strictly high grade roofing, either rubber or flint coat surface, with cement and nails complete.

Most liberal offer ever made on first class roofing. Better than goods that sell at much higher prices. Don't spend a dollar on roofing until you have seen

UNITO ASPHALT ROOFING

You send no money when you order Unito Roofing. Satisfaction Guaranteed. Write today for free samples for test and comparison and our unparalleled selling plan.

UNITED FACTORIES CO., Dept. A49, Cleveland, O.

Fruit-Growing

By Samuel B. Green

Fighting Plum Rot

THE sample of diseased plum received from Hemlock, Michigan, has plainly been destroyed by what is known as "brown rot of plums." This is frequently destructive to cherries, apricots, peaches and other stone fruits as well as plums. It is a fungous disease, that may even attack the flowers, causing them to rot, but generally does not do much damage until the fruit is about half grown. The plums blacken and some fall, while others dry on the tree. The disease spreads most rapidly in moist, warm weather.

The best treatment is to spray the trees before the buds open with Bordeaux mixture, and immediately after the flowers fall, and repeat at intervals of two or three weeks, applying Bordeaux until the fruit begins to color, when it should be withheld. This treatment is not only satisfactory in preventing loss from brown rot, but to a great extent prevents a number of other fungous diseases, including the so-called "shot-hole fungus." The Bordeaux mixture must be applied in a fine spray, and for this purpose you will need a spray pump, in order to use it to best advantage. Bordeaux mixture is made as follows:

Copper sulphate (blue vitriol), five pounds; quicklime (not slaked), not less than three and one half pounds, nor more than five pounds; water, fifty gallons.

Dissolve the copper sulphate and dilute to from twenty-five to thirty-five gallons. Slake the lime and add enough water to it to complete the required fifty gallons; then pour the two solutions together. Lastly, add any arsenical poisons which are to be combined with the Bordeaux mixture. This is a general fungicide for all fruit plants.

Sprays of this kind are preventive and not curative, and therefore must be applied before the injury becomes apparent, since after the fungus has secured lodgment in the plant it cannot be reached by fungicides.

Dwarf Pears Becoming Standards

T. A., Almagorda, New Mexico—A dwarf pear-tree is made such by reason of a pear being grafted or budded upon the quince. The portion of the tree above the union is just the same as it would be were it grafted upon some different kind of stock, and if this portion of the tree is planted deep, so that roots are sent out from above the union of pear and quince, the roots above the union will become large and put the pear-tree on its own roots, in which case the tree will take on the normal pear-tree size and form. In the case of dwarf pear-trees that are set with the union deep in the ground, this will naturally occur, and as a rule does occur when they are planted by those not familiar with them. In case they are set as they should be, in order to keep the pears dwarfed, this setting out of roots from the pear stock may be encouraged by making a mound about one foot high about the trees for a distance of several feet in every direction. This rooting is also helped if the bark of the pear-tree is slightly scarred with a knife deep enough to cut through the bark, as roots come from such places quicker than they do from the uninjured portion of the bark.

Wood-Ashes for Small Fruits

A. C. G., Chippewa Falls, Wisconsin—An application for unleached hard-wood ashes would probably help your strawberries and raspberries. I doubt whether you would get satisfactory results from lime, and unleached pine-ashes or coal-ashes would probably give you little or no fertilizing material. On the other hand, the use of these materials might under some circumstances improve the mechanical condition of your soil and thus prove beneficial. If you feel sure that your soil is deficient in lime, however, it would be well to try it, although if you apply wood-ashes, there will probably be sufficient time in them to supply the soil with all it needs.

Apple Grafts and Others

C. H., Montreal Junction, Quebec—Apple roots are often used for the stronger-growing varieties of pears, but as a rule cannot be used successfully for the better varieties. The root of the Blue Damson plum cannot be used as a stock for the pear or the cherry. Neither can you graft the cherry on the

pear scions or on Blue Gage plums. Blue Gage plum shoots from an ordinary tree will bear the same kind of fruit as the parent tree, provided that the parent tree was a seedling tree, but if the parent tree was a grafted or budded tree, then the shoots from the old tree are probably nothing but wild stock and worthless.

It is a pleasure to get questions of this kind from a man ninety-four years old, and I hope you may live long to enjoy the fruits of your labors. It seems to me it is a pity that more of our young men are not interested in matters of this kind, instead of in mere money-getting.

English Walnuts in Ohio

L. O. H., Bidwell, Ohio—English walnuts have sometimes been grown in Ohio in a small way, but the quality of the nuts is not first class and the trees are not perfectly hardy except in favorable locations. This tree is not ordinarily handled by Eastern nurserymen, as little or no progress has been made in cultivating this fruit in the Eastern states and only in a limited section in California can they be grown at a commercial profit. If you wish to try them, I would suggest that you take up the matter with some of the larger nurserymen, who can undoubtedly secure trees for you. I think that seedling nuts would be good enough for you to start with, and it is probable that on inquiry you may find there are a few trees of this growing within your region in Ohio.

Prairie Trees for Minnesota

G. W. B., Hutchinson, Minnesota—I think that on strong land, especially that which is somewhat moist, but not too wet for cottonwoods, you would get as good profit from Norway poplar as any tree that you would be likely to plant. Of course, it is only a form of the cottonwood, but now cottonwood lumber compares very favorably in price with most of our second-grade lumber and will make a saw-log in a short time. Plant them about twenty feet apart in rows eight feet apart. They will grow as thick as this for perhaps seven or eight years without injury, after which time every other tree must be taken out. Planted at this distance between the rows, there is good chance to cultivate them carefully for a much longer time than if the trees were set four feet. I should cultivate them until they shaded the ground well.

Freezing Apple-Seed

While I always prefer to freeze apple-seed before planting, yet I do not regard it as being absolutely necessary, and some growers get good results without freezing. If I expected to get apple-seed, as, for instance, seed shipped from Europe, after the warm weather of early spring comes on, I should soak the seed in cold water until it is plump and full, and should expect it to come up when sown. Some of our growers have tried the experiment of scalding the seed, but it is so easy to overdo this that I should hardly recommend it. If cold weather should come after the seed has been soaked, then I would put it out at night and allow it to freeze. One of my friends has experimented with some of our native tree seeds by freezing them in an ice-cream freezer, and felt that he got results that made it worth while for him to do so.

When to Prune Apple-Trees

L. C., Glens Falls, New York—The best time for giving apple-trees a light pruning is early in June. If, however, a heavy pruning is needed, the work should be done some time when the tree is dormant and preferably on mild days in the latter part of winter. All the wounds over three fourths of an inch in diameter should be covered with grafting-wax or a heavy coat of white lead. If trees are properly attended to, however, all they will need is a light pruning in June.

Two Crops on One Plot

IN PLANTING sugar corn, if you wish to raise two crops at once, without either interfering with the other, plant two or three hills of bunch (or bush) beans between each two hills of corn. If possible wheel manure between the rows to act as mulch and fertilizer after each plowing and hoeing. You can cut the corn any time and let the beans grow. C. E. DAVIS.

Amatite on Roof of Dunn Edge Tool Co., Oakland, Me.

Amatite Roofing
NEEDS NO PAINT

EVERYTHING nowadays is constructed with the view to save time; to save labor; to save money.

These are the primal points which have made Amatite successful. That these things have been achieved such letters as the one below fully prove.

"Oakland, Me., Feb. 2, 1910.

Barrett Mfg. Co.

During the past twelve years we have used several different brands of Ready Roofing; some of these have cost much more than Amatite, but we are free to say that we prefer the latter. Not only does it give fully as good service, but it requires no painting or coating, as some of the others do. We consider this a most desirable feature.

Yours truly,
DUNN EDGE TOOL CO.,
By R. W. DUNN, Treas."

These letters come to us constantly.

Amatite doesn't leak, and never needs to be painted. Its cost is low; its service long. It saves time, labor and expense.

Its real mineral surface and coal tar pitch waterproofing are responsible for this. We know what Amatite will do. We want you to know. Therefore we offer you a sample free.

Just send your name on a postal to nearest office.

BARRETT MANUFACTURING CO.
New York Chicago
Philadelphia Boston
Cincinnati Minneapolis
Cleveland Pittsburgh
New Orleans
Kansas City St. Louis

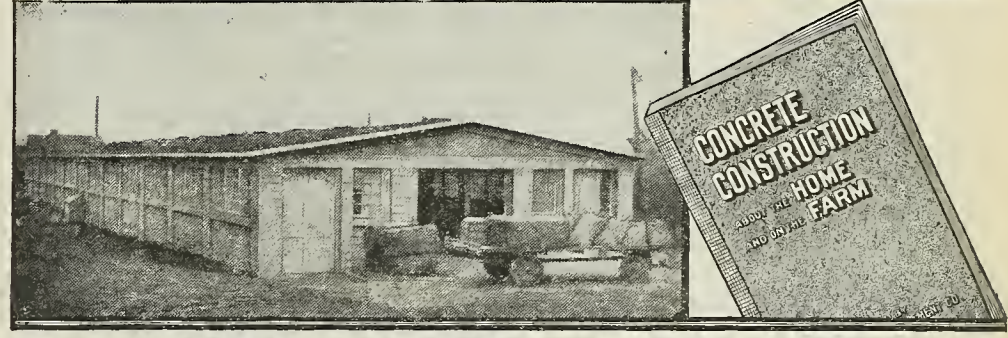

ATLAS PORTLAND CEMENT

Makes The Best Concrete

Progressive farmers are now making most of the small improvements around their farms of concrete. Any farmer can learn to build with concrete in a hundred useful ways.

When You Build With Concrete

When building with concrete be sure that ATLAS Portland Cement is used—and you can be sure of the strength and durability of your structure.

ATLAS stands every test for strength, composition, color, fineness and uniform quality. It is the standard American brand. There is only one quality manufactured—the best that can be made, and the same for everybody.

ATLAS Portland Cement is made of genuine Portland Cement rock. It contains no furnace slag.

The U. S. Government has ordered 4,500,000 barrels of ATLAS for use on the Panama Canal.

Write For Free Book

Our illustrated book, "Concrete Construction About the Home and on the Farm," tells how to mix and use concrete and gives diagrams and specifications for many farm structures. It contains 168 instructive pages with 150 illustrations. Write for it today.

Ask your dealer for ATLAS. If he cannot supply you, write to

THE ATLAS PORTLAND CEMENT COMPANY
DEPT. 122, 30 BROAD STREET, NEW YORK
Daily Productive Capacity, over 50,000 Barrels—the Largest in the World.



Fountain-Pen Without Cost

Our Offer

THE Handy Fountain-Pen is one of the best pens made for usefulness and wearing qualities. It is a fine, well-made gold-tipped pen. It is made of vulcanite, which is like hard rubber. There is a close-fitting dust-cap to protect the pen. For steady use this pen cannot be beaten. It is easily filled and a filler is furnished with each pen. The special feature of the Handy Pen is its free-flowing ink, requiring no shaking. This Handy Fountain-Pen will be the most useful article you could have. It is simply perfect and will be a constant delight. Show them a copy of FARM AND FIRESIDE. If you haven't one, send us a postal. We have delighted many people with this pen. Send us the \$1.00 and the four names, and we will at once send you this Fountain-Pen by return mail, without cost. Address

FARM AND FIRESIDE, SPRINGFIELD, OHIO

You can get this useful Fountain-Pen if you will get four of your friends each to give you 25 cents for an 8-month subscription to Farm and Fireside. Tell them this is a special reduced-price subscription offer that only you can offer them. (The regular price for an 8-month subscription is 35 cents.) You can easily get four friends to subscribe, for they will be only too glad to get the biggest, best, and handsomest farm and family paper for eight months for only 25 cents.

WANTED—RIDER AGENTS

IN EACH TOWN and district to ride and exhibit a sample 1910 Model "Ranger" bicycle furnished by us. Our agents everywhere are making money fast. Write at once for full particulars and special offer.

NO MONEY REQUIRED until you receive and approve of your bicycle. We ship to anyone, anywhere in the U. S. without a cent deposit in advance, freight, and allow **TEN DAYS' FREE TRIAL** during which time you may ride the bicycle and put it to any test you wish. If you are then not perfectly satisfied or do not wish to keep the bicycle you may ship it back to us at our expense and you will not be out one cent.

LOW FACTORY PRICES—We furnish the highest grade bicycles at prices possible to make at a small profit above actual factory cost. You save \$10 to \$25 middlemen's profits by buying direct of us and have the manufacturer's guarantee behind your bicycle. **DO NOT BUY** a bicycle or a pair of tires from anyone at any price until you receive our catalogues and learn our unheard of factory prices and remarkable special offer.

YOU WILL BE ASTONISHED when you receive our beautiful catalogue and study our superb models at the wonderful low prices we can make you. We sell the highest grade bicycles at lower prices than any other factory. We are satisfied with \$1.00 profit above factory cost. **BICYCLE DEALERS**, you can sell our bicycles under your own name plate at double our prices. Orders filled the day received.

SECOND HAND BICYCLES—a limited number taken in trade by our Chicago retail stores will be closed out at once, at \$3 to \$8 each. Descriptive bargain list mailed free.

TIRES, COASTER BRAKE rear wheels, inner tubes, famps, cyclometers, parts, repairs and everything in the bicycle line at half usual prices.

DO NOT WAIT—but write today for our Large Catalogue beautifully illustrated and containing a great fund of interesting matter and useful information. It only costs a postal to get everything. Write it now.

MEAD CYCLE CO. Dept. B-83, CHICAGO, ILL.

MONTROSS METAL SHINGLES

Withstood hardest kind of service over 21 years. No experiment. Last life of building. Outwear wood shingles. Easily laid. Galvanized or Painted. Fire, Lightning and Stormproof. Ornamental. Inexpensive. Catalogue gives full information of their superior value, testimonials, illustrations, prices, etc. WRITE TODAY.

MONTROSS METAL SHINGLE CO., Camden, N. J.

GET THIS FREE BOOK BEFORE YOU BUY ANY KIND OF VEHICLE HARNESS



30 days' trial.
2 years guarantee.
Safe delivery insured.

See **Murray's big values** and compare them with others—before you place your order

Be your own dealer. Save 25% to 40%

The easiest—and the only way to be sure of getting the best vehicle for YOUR particular purpose at the very lowest price is to send for the big

1910 Murray Style Book of Vehicles and Harness

and compare carefully point by point the various vehicles shown in it with the vehicles offered by others.

Send for this catalog today. Make this comparison from YOUR OWN STAND-POINT. See which vehicle has the greatest number of desirable exclusive features and is best fitted for your own use. Then place your order with the firm who offers you most. Murray will abide by your judgment.

Murray is the oldest and best known big maker in America. He sells direct—undersells all others—save you two big profits.

And the Murray Style Book is the largest, most conveniently arranged, best illustrated vehicle catalog published.

It offers by far the greatest variety—offers you splendid opportunity for savings, no matter what kind of vehicle you want.

Every vehicle is sold on thirty days trial—with a two years guarantee—and safe delivery insured. Send for this book at once. Compare it with all others.

It will surely save you money. Write us today.

The Wilber H. Murray Mfg. Co.
1322-1328 E. 5th St.,
Cincinnati, Ohio.

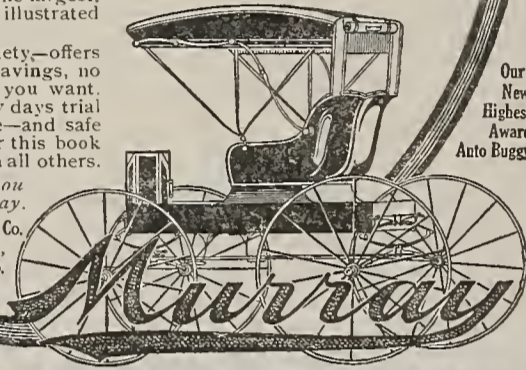

Our New Highest Award Auto Buggy

A Penny Postal brings you 192 Pages—345 illustrations of unmatched Murray values. Send NOW!

Read This Farmer's Experience

With **Galvanite** Reprinted From "Experience Column" St. Paul Farmer Dec. 1st 1909

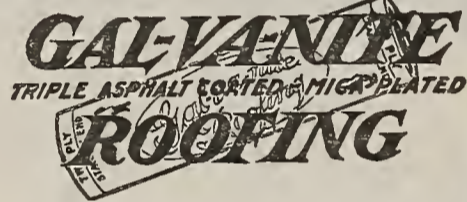

THINKS ROOFING ALL RIGHT

To The Farmer:

I noticed in the Farmer for last month an article by a man, who, in giving his experience with roofing, claims all kinds of prepared roofing a failure and avers that shingles are the only thing. Now I have tried shingles, and as a result, my dwelling house burned down five years ago, being set on fire by a spark from the chimney. Some may say, why did you not paint your shingles? That is all right; I have seen painted shingle roofs, on which the shingles were rotted right in to where the water runs on to them from the shingles above. No more shingles for me. I have now on my new house some kind of roofing that is called galvanite, and I got it five years ago when I built. It has stood the test of water and fire, as big balls of fire lit on it two years ago when the big brush fires were raging up in this country, and it did not show on the roof at all. It is coated with mica and it is not, like the roofing coated with crushed stone, stiff and hard to lay, but very soft and pliable. It is asphalt coated; no pitch will run down your roof in the hot summer weather, and it is today just as good as the day I laid it five years ago. It looks as though it is going to last as long as I live.

CHARLES OSTERLIN.



Booklet & Samples FREE

Send for them today, a postal will do.

Union Roofing & Mfg. Co.

Main Offices & Factories
1143-1157 East 7th Street,
ST. PAUL, MINNESOTA

It is to your advantage to mention Farm and Fireside in writing to advertisers. Farm and Fireside folks get the very best attention.

\$15.95
AND UPWARD

THE LOW DOWN AMERICAN SEPARATOR
EXCELS ANY SEPARATOR IN THE WORLD



THIS OFFER IS NO CATCH. It is a solid, fair and square proposition to furnish a brand new, well made and well finished cream separator complete, subject to a long trial and fully guaranteed, for \$15.95. It is different from anything that has ever before been offered. Skims 1 quart of milk a minute, hot or cold, makes thick or thin cream and does it just as well as any higher priced machine. Any boy or girl can run it sitting down. The crank is only 5 inches long. Just think of that! The bowl is a sanitary marvel; easily cleaned and embodies all our latest improvements. Gears run in anti-friction bearings, and thoroughly protected. Before you decide on a cream separator of any capacity whatever, obtain our \$15.95 proposition.

OUR LIBERAL TRIAL ENABLES YOU TO DEMONSTRATE THIS. While our prices for all capacities are astonishingly low, the quality is high. Our machines are up to date, well built and handsomely finished. Run easier, skim closer, have a simpler bowl with fewer parts than any other cream separator. Thousands of machines in use giving splendid satisfaction. Write for our 1910 catalog. We will send it free, postpaid. It is richly illustrated, shows the machine in detail and tells all about the American Separator. Our surprisingly liberal long time trial proposition, generous terms of purchase and the low prices quoted will astonish you. We are the oldest exclusive manufacturers of hand separators in America and the first to sell direct to the user. We cannot afford to sell an article that is not absolutely first class. You save agent's, dealer's and even catalog house's profits by dealing with us and at the same time obtain the finest and highest quality machine on the market. Our own (manufacturer's) guarantee protects you on every American Separator. We ship immediately. Western orders filled from Western points. Write us and get our great offer and handsome free catalog. ADDRESS,

AMERICAN SEPARATOR CO., BOX 1058, BAINBRIDGE, N. Y.

The Cow in the Making

A FEW years ago we bought a calf that we brought home covered up from head to foot with a blanket. The little thing stood all the way, no doubt wondering what in the world she had done to be worthy of such a punishment. The dear good woman who sat on the seat with me kept cautioning me to "keep the blanket tucked in;" and why?

Well, she had a bit of pride about the matter. Nobody ever had seen such a looking calf on our farm and she felt that it would somehow be a bit of disgrace to us if now we should be seen carrying home in a wagon, as if we had found some great prize, a calf that was, as she put it, "about as big as a pint of cider!" The calf really was not such a beauty to look upon at that time, and yet she has for a long time been the best cow on the farm.

It seemed to me there was something about that calf that promised well. It was well born, from registered stock. The mother was surely a good cow if looks counted for anything and then, too, she had the figures to back the appearance up.

We brought that calf up really and truly by hand. Knowing how the mistress of the farm felt about it, I put in some extra good licks in care and feeding, so that I might not altogether prove my utter lack of sense in the matter of picking out a calf. The calf had been having stock-food, and to drop that and get it over on real milk was indeed pretty ticklish business; but by beginning carefully with skim-milk and not a very heavy ration of that, and adding some grain to the amount given, it was not long before the calf began to show real signs of living. I never have been afraid of a calf with a big belly since then. That is a thing we may some day be thankful for. To eat and digest a good supply of food, the cow must have plenty of room. This conviction was afterward deepened when, in corresponding with a gentleman of whom I had bought another thoroughbred calf, I remarked that "she is somewhat inclined to be pot-bellied." The man, took that up quick and replied that the time would come when I would be thankful my calf did have a good big body. And he was right.

Our plan of feeding that calf was to give a small quantity of milk at a time, and give it often. There is a great deal more danger in feeding too much in two rations a day than there is in giving the same amount at three or four feedings. I have seen fine calves spoiled by being overfed. The owner was in a hurry to see them grow fast and overdid the matter. Slow at the beginning is the best rule.

And then, I have learned the value of buckwheat shorts as a calf-feed. I know of nothing better. But this should be fed dry and never stirred into the milk. It is plain why not if we stop and think. Calves are like people. They need to chew their food. If swallowed whole, as grain must be if given in the milk, down it goes and forms a harsh mass in the stomach. But if fed in a box dry, the calf can lick it and moisten it with the saliva and so digest it more readily.

Very soon after we got the calf home—it was then five or six weeks old—we began to feed hay. Taking a potato-crate, we filled it with nice bright hay and set it near the calf. At first about the only use the calf had for it was to bunt it over in the course of its fun; but really it did us good when the little thing got to feeling well enough to kick up her heels and show signs of living. But it was not long before she began to pick out here and there a spear of hay and nibble it. It tasted good; here was something to chew, and that means much to a calf, so it was not long before that crate of hay began to mean something to her. That ended all danger of bowel trouble, for if you can get a calf to eating hay regularly, it will regulate the bowels and act as a tonic.

That is the way we brought up that calf. It was work, but we enjoyed it as we went along; and surely there never has been a time since we began to milk her that we have not been proud of Juno, the best cow on the farm.

E. L. VINCENT.

Early education with a colt is as important as it is with the boy.

The farmer is a sort of a god in the eyes of his stock—if he treats it right.

Don't let milk dry on the utensils. And when set away, don't let the vessels be where dust can reach them. Dust is full of bacteria.

What can be done with two cows was shown last year by Mrs. Albert Smith, near Covington, Tennessee. These cows supplied a family of seven with all the butter they wanted. Besides, Mrs. Smith sold six hundred pounds at an average of twenty cents per pound, or a total of one hundred and twenty dollars.

Driven Home

This personal, unsolicited letter is from the first purchaser of a

Sharples Tubular Cream Separator

in Kearney County, Nebraska. You could not ask a better one.

"Minden, Neb., March 1st, 1910.

To Farmers: I bought the first Sharples Tubular No. 4 that was sold in Kearney County, 11 years ago. This machine has been in constant use ever since and I believe it is as good as the day I bought it. I have been milking from 6 to 14 cows during these years, until two years ago, when I turned the machine over to my son, who is still using it on the farm. This machine has not cost us one cent for repairs of any kind. It turns easy and skims perfectly. It



is easy to oil, as you just pour a cup of oil on the wheels and the wheels run in oil. It is easy to clean, as there are only two pieces to the bowl to wash. It is always in shape, as there is less machinery about it than any other machine.

PETER SODERBERG."

Tubular superiority has driven home to farmers the fact that Tubulars are The World's Best. Sales easily exceed most, if not all, others combined. Tubulars probably replace more common separators than any one maker of such machines sells. World's biggest separator works. Write for Catalogue No. 112

THE SHARPLES SEPARATOR CO.,
WEST CHESTER, PA.
Chicago, Ill. San Francisco, Cal. Portland, Ore.
Toronto, Can. Winnipeg, Can.

EXCELL IRON and STEEL ROOFING and SIDING

Send today for Free Book and bottom Factory Prices on Metal Roofing and Siding. Made in our own factory. Better than you can buy elsewhere at any price. Shipped at our risk. You **Send No Money** so you take no risk. Our guarantee and see-what-you-buy-before-paying-Plan specify you pay nothing unless fully satisfied. Lowest prices on all roofing and roofing supplies sold straight to you from Factory at real Factory Prices. Don't buy till you get our prices and **FREE Roofers' Guide**—Write for this Book today. The United Factories Co., Dept. R49, Cleveland, O.

OSGOOD SCALE

Pitless Indispensable on every farm; saves the time and money you would spend on a public scale, and assures perfect accuracy all ways. Priced within your reach; good for a lifetime. Osgood Scale Co., Box 125 Blghampton, N. Y. Write for Catalogue \$45 to \$80

ELECTRIC Steel Wheels

for your wagon. Use your old running gears—our steel wheels will fit them and make your wagon good as new. Send for free catalog of solid metal wheels (sizes to fit all axles) that cannot swell, dry apart or rot. Make a new wagon out of your old one. Write for the book now to **ELECTRIC WHEEL CO., Box 13 QUINCY, ILL.**

Battleship Post-Cards

20 Views of Our Biggest Fighters in Colors. We will send you the complete set of 20 Battleship Post-Cards if you will send us 10 cents each for two three-month trial subscriptions to FARM AND FIRESIDE: The two trial subscriptions must be new subscriptions. Send the 20 cents for the two subscriptions in coin or stamps.

FARM AND FIRESIDE, SPRINGFIELD, OHIO

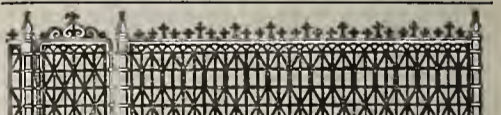

Ornamental Fence Cheaper than wood for Lawns, Churches, Cemeteries, Public Grounds. Also Wrought Iron Fence. Catalogue free. Write for Special Offer. **THE WARD FENCE CO., Box 176, Decatur, Ind.**

FENCE Strongest Made

Made of High Carbon Double Strength Coiled Wire. Heavily Galvanized to prevent rust. Have no agents. Sell at factory prices on 30 days' free trial. We pay all freight. 37 heights of farm and poultry fence. Catalogue Free. **COILED SPRING FENCE CO., Box 18 Winchester, Indiana.**

DON'T DIG WHEN IT'S QUICKER TO BORE

Standard Post-Hole Auger is the tool you need for fence work, tree planting, post-holes, etc., etc. Bores like a drill; dumps like a shovel. Get Our Free Catalogue 26 **STANDARD EARTH AUGER CO., 1128-1134 Newport Ave., Chicago, Ill.**

PATENTS SECURED OR FEE RETURNED.

Free report as to patentability. Illustrated Guide Book, and List of Inventions Wanted, sent free. **VICTOR J. EVANS & CO., WASHINGTON, D. C.**

PATENT YOUR IDEAS. They may bring you wealth. 64-page Patent Book Free. Fitzgerald & Co., Atty's., Box N, Washington, D.C. Est. 1880

CALVES RAISE THEM WITHOUT MILK

Booklet Free **J. W. BARWELL, Waukegan, Ill.**
Wanted! Young Men! Railroad! Brakemen. Baggage-men, Electric Motormen, Conductors. Experience unnecessary. Instruction by MAIL. Application blank and book for stamp. Inter Ry. Inst. No. 36, Indianapolis, Ind.

The U.S. will
**SAVE ALL YOUR
CREAM**

The 1910 Interlocking Style

**U. S. CREAM
SEPARATORS**

are money earners, being cream savers. Pan-American World's Record proves it, Seattle

Grand Prize assures it.

Buying a U. S. is not an "Expense" But an "Investment" paying big dividends



The envy of competitors The joy of owners

Year in and year out they run without a hitch, ever making money, never making trouble.

- 1st. The U. S. skims the cleanest.
- 2nd. The U. S. is built the strongest.
- 3rd. The U. S. is the easiest to clean.
- 4th. The U. S. is the most convenient.
- 5th. The U. S. requires least power.

The U. S. defeated all other Separators at Seattle on these five essential points and

WON GRAND PRIZE

If your dealer cannot supply you, send us his name and ask for Catalogue 69 just out. The best ever issued by any Separator company.

Vermont Farm Machine Co.
Bellows Falls, Vt. U.S.A.

Live Stock and Dairy

Why Cow-Testing Associations Pay

VERMONT has recently organized a State Cow-Testing Association, this being considered the best way to promote the work. The officers are men in charge of first-class dairies, either as owners or managers. President Wiggin, of Quechee Fells Farm, recently said: "To get two cows into the hide of one lightens labor, lessens feed-bills, increases profits. It prompts the better care of stock, better feeding methods, better results, hence better profits. It would be money made to confiscate and destroy the cow which robs her owner. Testing picks her out. It also helps to keep track of the creameryman's test, shows whether the separator skims clean and increases the value of all the cows one has for sale. As proof from my own herd, testing and weeding has raised the average yield from two hundred and six to two hundred and sixty-five pounds."

Three of Vermont's seven associations have been organized three years and

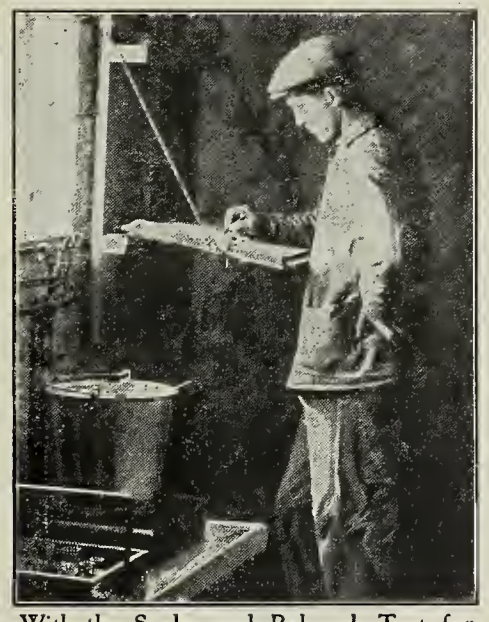

With the Scales and Babcock Test for Working Tools

every member is well pleased with the results. A new association being formed at St. Albans will add about one thousand cows to the list of those under test, which now number four thousand. Dean J. L. Hills, of Vermont Agricultural College, agitates the matter at every opportunity. Addressing the State Dairymen's Association, he said: "Cow-testing associations once more? Yes, twice, thrice, a hundred times more, until they are thicker on the map of the Green Mountain State than were the freckles on my boyhood's face. He who lets but one cow eat grass where two used to eat it merits applause, provided that one makes as large a return as did the two. That is just what this associated effort is directed toward. Its purpose is to discard dead-beats and detect drones. Let farmers in their several communities form Amalgamated Associations for Bovine Betterment, with scales, Babcock test and the ax for their working tools; with 'more milk' and 'more money' for the pass-words; with 'breed, weed and feed' as the three cardinal maxims, and 'Excelsior' for their motto—and then let them stick to it through thick and thin, and improvement is certain."

Canada has over fifty associations and, aside from these, which are aided by the Department of Agriculture, many individual farmers have taken up the work on their own behalf. As a sample of what the tests show, the cows in one association gave an average yield of 26.6 pounds of fat in thirty days, in another 32.2 pounds fat in the same time. The point is that the lesser yield might be raised to equal the greater by weeding out. Said Dean Hills: "A simple word of advice that means thousands of dollars to our farmers is just this, get rid of the poor cows and feed the pretty good cows more liberally."

There is no association near enough to include our dairy. We do not own a Babcock tester, but as our cream is sold under the cream-gathering plan to a near-by creamery, we are not without facilities for testing. Bottles are obtained at the creamery, samples of milk taken and the man at the creamery tests for patrons free of charge. It is his interest to do so. By weighing the milk from time to time, testing twice or three times during the milking period and being observant of the time the cow goes dry, the amount of hay she consumes, whether she responds to extra feeding,

etc., a pretty fair estimate is formed of her worth. This is not as accurate as the work done by our association, but it is far and away ahead of no testing, is inexpensive and sets a man thinking on things that he is too apt to leave unnoticed. No one after once knowing what their herd was actually doing would ever go back to the old haphazard way. It would be like turning off electric-lights to sit by a tallow-dip.

In these days of high prices for feed, help and building-material, only the good cow pays her way. Statistics show that the average per cow throughout the country is only about one hundred and forty pounds. Taking into account the many extra good ones, the record of many others drops to an appallingly low figure. Such cows should be weeded out—and how are they to be found except by testing?

The quantity of milk does not tell the story. I had a neighbor who swapped cows with another neighbor. The cow swapped for gave a lot of milk, but she had been tested and her owner knew that she never made half a pound of butter a day in her life. The new owner, however, considered her the best cow he had. He kept her and raised her stock until nearly his whole herd consisted of it, then grumbled at his butter checks and tests, believing the creamery cheated him. A little time and trouble testing would have put five hundred dollars in his pocket in the years he owned those cows.

J. W. M.

Not Quite Orthodox

IN THE ISSUE OF FARM AND FIRESIDE OF January 10, 1910, Mr. Kester writes upon methods of ripening cream and of churning, in some points of which it seems he is not quite orthodox. He writes: "Cream is ripened and the flavor produced by the development in the cream of certain bacteria. These enter it either by chance or by the addition of a 'starter' that is, a small portion of cream already containing them and kept from one churning to another."

We agree with the writer that the bacteria, good, bad and indifferent, introduced by design and chance are the vital factor. But we know that some of the adverse type that have a decided affinity for the butter-fat in the cream are indefinitely carried forward with his cream starter. Thus the quality of the butter is thrown off and this is especially true when the cream for the churning is ripened to the stage where the whey separates from the cream and of course advances in fermentation while cooling down awaiting a convenient time to churn. It would seem to be a much better practice to create a starter from carefully-drawn whole milk or skim-milk, to which a very small part of buttermilk of fine flavor may be added to start fermentation of the "starter" if it were wanted promptly.

Again we think sixty-eight degrees too high for the maximum temperature for winter churning; we think it would injure to some extent the quality of the butter and that the churning would not be very exhaustive. There would be more than one tenth per cent of butter left in, the buttermilk.

READER.



THE BEST INVESTMENT ANY COW OWNER EVER MADE

That's what MORE THAN A MILLION COW OWNERS the world over have found the DE LAVAL CREAM SEPARATOR to be, after thirty years of separator use.

A DE LAVAL FARM SEPARATOR costs from \$40.- to \$175.- according to capacity. It saves butter fat and produces a cream of superior quality over any setting system or any other separator every time it is used,—twice a day every day in the year.

It involves far less labor than any setting system, and runs easier, has greater capacity and lasts from two to ten-times longer than any other separator.

That's how a DE LAVAL separator saves its cost at least the first year, and frequently in a few months, and then goes on doing so right along for an average of twenty years.

Any desired separator information can be had of the nearest DE LAVAL local agent or of the Company directly.

The De Laval Separator Co.

165-167 BROADWAY NEW YORK	178-177 WILLIAM ST. MONTREAL
42 E. MADISON ST. CHICAGO	14 & 15 PRINCESS ST. WINNIPEG
DRUMM & SACRAMENTO BLDG SAN FRANCISCO	1018 WESTERN AVE. SEATTLE

You can lay it yourself

Congo is the ready roofing you will hear about from your neighbors. It gives such good satisfaction, costs so little, is so easy to lay and is so waterproof that you cannot help talking about it. There is absolutely nothing in Congo that will cause it to rust, rot or dry out, or be affected by acid.

A 10 year Guarantee Bond in every roll of 2 or 3 ply. Sample free for the asking—also copy of the Bond.

UNITED ROOFING & MFG. CO.
553 West End Trust Bldg. Philadelphia, Pa.
Chicago San Francisco

WHEELS, FREIGHT PAID \$8.75

for 4 Buggy Wheels, Steel Tires. With Rubber Tires, \$15.20. 1 mfg. wheels 3/4 to 4 in. tread. Buggy Tops \$3.50, shafts \$2.00. Top Buggies \$35; Harness \$5. Learn how to buy direct. Catalogue Free. Repair Wheels, \$5.50. Wagon Umbrella FREE. P. E. 200B, Cincinnati, O.

LET ME START YOU IN BUSINESS!

I will furnish the advertising matter and the plans. I want one sincere, earnest man in every town and township. Farmers, Mechanics, Builders, Small Business men. Anyone anxious to improve his condition. Address **COMMERCIAL DEMOCRACY, Dept. 19, ELYRIA, OHIO.**

Try Kerosene Engine

30 Days Free

Gasoline Prices Rising

You can't run a farm engine profitably on gasoline much longer. Price of gasoline going sky high. Oil Companies have founded the warning. Kerosene is the future fuel and is now 6c to 10c a gallon cheaper than gasoline. The Amazing "DETROIT" is the only engine that uses common lamp kerosene (coal oil) perfectly. Runs on gasoline, too, better than any other. Basic patent. Only 3 moving parts. Comes complete ready to run. We will send a "Detroit" on free trial to prove all claims. Runs all kinds of farm machinery, pumps, saw rigs, separators, churns, feed grinders, washing machines, Silo fillers and electric lights. Money back and freight paid both ways if it does not meet every claim that we have made for it. Don't buy till you get our free catalog. 2 to 24 h. p. in stock. Prices "stripped," \$29.50 up. Special demonstrator agency price on first outfit sold in each community. 2000 satisfied users. We have a stack of testimonials. Write quick. (52)

The Amazing "DETROIT"

DETROIT ENGINE WORKS, 133 Bellevue Ave., Detroit, Mich.

The Importance of Clipping Horses



before they are put at the hard spring work is now recognized as the proper thing by progressive farmers everywhere. Horses are soft in the spring and sweat easily. Long hair holds this sweat and dirt, making it difficult for the skin to perform its functions properly. The wet coat is slow to dry, too, and leaves the horses liable to coughs, colds, pneumonia, and other ills. **Clipped horses dry out quick, rest well, and get more good out of their food.** A blanket, on cold nights, is much better than long, wet hair. Clipped horses look better, feel better, and do better work every time.

You can clip a horse in 30 minutes with the **Stewart Ball-Bearing Clipping Machine, only \$7.50**

It is the finest clipping machine ever made. We have been making clipping machines for 20 years and it is our masterpiece. It's the only ball-bearing clipping machine. The gears are all cut from solid steel, are made file hard, and are shut in away from dust and dirt. They run in oil, too, doing away with almost all friction and wear. The knife is the famous Stewart single nut tension pattern, highest grade. **So good is this machine that we guarantee it to you for 25 years** No other machine ever made is so well worth the money.

You can get this machine from your dealer, or send \$2.00 and we will ship C.O.D. for balance. Get one NOW. Write for big, new catalogue.

CHICAGO FLEXIBLE SHAFT CO.
124 LA SALLE ST., CHICAGO

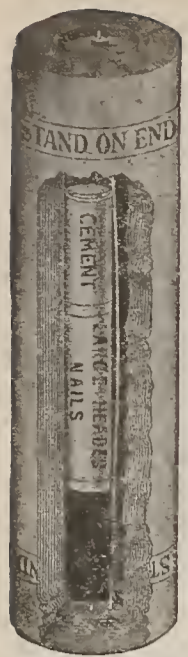

INDRUROID ROOFING

Requires no Coating or Paint.
Acid and Alkali Proof.
Elastic and Pliable Always.
Strong and Tough.
Absolutely Waterproof.
Climatic Changes Do Not Affect It.
Practically Fire Proof.
Can Be Used on Steep or Flat Surfaces.
Any Workman Can Put It On.
No Odor.
Will Not Shrink or Crack.
Light in Weight.
Does Not Taint Water.

Write for samples, prices and circulars.

H. F. WATSON CO.
ERIE, PA.
Chicago. Boston
Mention F. & F.

SIMPLE, PRACTICAL, \$5.00



Why pay a fancy price for a separator when you can buy one which produces more and better cream in the shortest time—takes up less room and costs one-tenth as much as an intricate and expensively operated machine. The **ARRAS CREAM SEPARATOR** is simplicity itself. No inner tubes, corrugations, or deep angles to clean; no corrosion, no submerison, no pan lifting, no dilution. Used and proven highly satisfactory by thousands of our customers in all parts of the country. Strongly built and absolutely guaranteed. Money refunded if not satisfactory after 20 days. Send for free instruction catalogue—it contains money-getting information regarding milk and butter.

ARRAS CREAM SEPARATOR CO., 52 Main Street, Bluffton, O.

Shoe Boils, Capped Hock, Bursitis are hard to cure, yet

ABSORBINE

will remove them and leave no blemish. Does not blister or remove the hair. Cures any puff or swelling. Horse can be worked, \$2.00 per bottle, delivered. Book 6 D free. **ABSORBINE, JR.**, (mankind, \$1.00 bottle.) For Boils, Bruises, Old Sores, Swellings, Gout, Varicose Veins, Verrucae, etc. Always Pain. **W. F. YOUNG, P. O. F., 23 Temple St., Springfield, Mass.**

SILOS

Recognized as the standard because of their massive strength, surpassing durability, perfect convenience, proven merit. Used by U. S. Government. Send for catalog. **HARDER MFG. CO., Box 31, Cobleskill, N.Y.**

BROWN FENCE

STOUT—STRONG—DURABLE—CHEAP
Let us prove to you that Brown Fence will outlast any other because of heavier wire and heavier galvanizing. Investigate before you buy. 160 styles for all purposes. 15c per rod up—We Pay the Freight. Send today for prices and free sample of all No. 9 Rust Proof fence. The **BROWN FENCE & WIRE CO., Dept. 216, Cleveland, O.**

SAMPLE FREE



THE RATCHET WIRE SPLICER

Will wrap with ease the hardest steel wire in the narrowest space in a woven wire fence. Sells at sight. Big money for agents. By mail post paid for 50 cents. **A. B. PROBASCIO, Lebanon, Ohio.**

LEARN TO WRITE ADVERTISEMENTS IF YOU ARE EARNING LESS THAN \$25 A WEEK we can positively show you by mail how to increase your salary. Send for beautiful prospectus, mailed FREE.

PAGE-DAVIS SCHOOL, Dept. 25, Chicago, Ill.

FARM WANTED We want to hear from OWNER having good FARM for sale in good locality. State lowest price, as you will have no COMMISSION to pay. If you want to buy property of any kind it will be to your interest to write us. **AMERICAN INVESTMENT ASSOCIATION, 815 Palace Bldg., Minneapolis, Minn.**

PATENTS WORTH FORTUNES Inventors: Send 6 cts. for our Valuable Patent Books **B. S. & A. B. Lacey, Dept. 49, Washington, D. C. Est. 1869**

14 3/4 Cents a Rod

For 22-in. Hog Fence; 15 3/4-c for 26-inch; 18 3/4-c for 31-inch; 22c for 34-inch; 25c for a 47-inch Farm Fence; 50-inch Poultry Fence 35c. Sold on 30 days trial. 80 rod spool Ideal Barb Wire \$1.55 Catalogue free. **KITSELMAN BROS., Box 271, MUNCIE, IND.**

It is to your advantage to mention Farm and Fireside in writing to advertisers. Farm and Fireside folks get the very best attention.

Live Stock and Dairy

Safe Calving

A LETTER from a subscriber at Raspeburg, Maryland, opens the whole interesting and important subject of the management of the cow preparatory to and after calving. That is the time when her owner can do the cow the most good or, if he proceeds wrongly, the most harm.

I believe that the manner in which a cow is prepared for freshening and the manner in which she is fed for the first thirty days following freshening decides very materially the work she will do for the entire year. Invariably the cow should be turned dry for at least six weeks prior to freshening and fed well during her vacation.

In the past it has largely been the practice to feed dry cows very little because they were not making milk. As a matter of fact, the greatest profit to be received out of feed given to dairy cows is for that feed which the cow gets while she is dry. A cow freshening in strong, thrifty, vigorous and a rather fleshy condition will not only give more milk, but her milk will test richer than if she freshens poor and emaciated or tired out from her previous year's campaign.

After the cow has freshened, it matters less what kind of food is given or in what quantities. It is impossible to raise materially for any length of time the percentage of fat in the milk. By storing fat up on the body while the cow is dry, however, it is possible to transfer that fat later to the pail in the form of milk or butter-fat, and by so doing the quantity of milk is not only increased, but also is the quality.

There was a time when it was not advisable to follow this plan because a fleshy cow is more susceptible to milk fever than a cow that is poor. This argument does not stand any longer, since the air treatment and oxygen treatment have been demonstrated as so efficient in curing this malady.

It is difficult to turn some highly-bred, persistent workers dry. In order to do this they should be placed on dry feed, in sparing quantities, for a few days. The cow during this time should be milked only once a day—later once every other day, always leaving a small amount of milk in the udder. It should take only a few days where the feed is withheld, especially all succulent feed, until the cow is sufficiently dry so that she needs to be milked only occasionally, if at all.

When the cow stops giving milk, feeding should begin at once for the following year.

When the cow is dry, there are three specific purposes for which she should be fed. In the first place, if she is a good, hard-working cow, her last year's work has been wearing on her and she should have a rest. The digestive apparatus of a dairy cow is the first part of her anatomy to give away under heavy feeding and this in particular should be rested up. To accomplish this purpose, feeds of a cooling and light, bulky nature should be fed. If the cow is dry in the summer-time, there is nothing better than blue-grass. In the winter, nothing better than silage.

Secondly, we need to build up the future calf. During the last six weeks of gestation the fetus makes its largest growth and this growth is entirely of cartilaginous material and muscle. Experiment after experiment has demonstrated that nothing will grow bone and muscle, blood, hair, horn and hoof except the nitrogenous or the protein portion of the feed. For this purpose give all the alfalfa or clover hay that a cow can eat as roughage and, by way of a grain ration, oil-meal and bran. These last, also, are resting and cooling to the digestive apparatus and keep it in good order.

The third purpose is to store up in the animal's body fat to be drawn upon later, as well as stamina for her work during the next year. To make fat, nothing is better than corn given in the form of corn-silage with a small amount of grain finely ground. There is nothing that will impart stamina to an animal with more efficiency than oats. Horsemen have always realized this. So, although oftentimes oats are too expensive to feed at any other time during the year, I am confident that the cow should be fed well on ground oats during her resting period. They also rest the digestive apparatus and supply protein.

The basis of the dry cow's ration, then, should be as much corn-silage, alfalfa or clover hay as she will clean up; then a mixture of equal parts of finely-

ground corn and oats, oil-meal and bran. This should be fed in amounts according to the condition of the cow. If she is in poor flesh, she should be gradually brought to a ration of from eight to ten pounds of grain daily. If she is running on good grass, then the grain ration, of course, will be sufficient without the roughage named.

It will be surprising when the cow approaches freshening to see what a wonderful udder development she will begin to make, and by the time she has freshened, her feeder will be surprised to note that she has a larger and much better developed udder than he has ever seen on her before under different conditions.

It is true that at calving-time such a cow needs more care than one not so well prepared for her year's work, and during the first forty-eight hours she should be watched closely and at the first symptoms of milk fever the air treatment should be applied.

During the freshening period a cow should be reduced to a bran-mash mixed in warm water—an excellent one is two pounds of bran, a pound of oats, a pound of oil-meal and a handful of salt. Such a ration given twice daily, providing she is not sick with the fever, at which time no feed should be given, will carry her through in good condition. If at calving-time the cow is not in a laxative condition, it is wise to give her a pound of Epsom salts. If she will not eat the salts in her feed, they should be given her in a liquid form—in a drench if care is taken not to strangle her. Of late, however, I have been inclined to believe that there is more danger in drenching cows than in most diseases. Doctor Roberts, the cattle specialist, has advised me that the manner to give medicines is to insert a probang direct to the stomach and give the medicine through this. The probang is only a long hose-like affair which, I presume, can be obtained from any veterinary medical-supply house. **HUGH G. VAN PELT.**

No Doubt About Mangels

AN OHIO subscriber is doubtful whether beets or mangels are beneficial to dairy cows in increasing butter-fat or otherwise.

Sugar-beets and mangels are very beneficial in that they increase the production of milk without decreasing the percentage of butter-fat, and in this way the total amount of butter-fat produced is increased.

In the old countries mangels, especially, are used very largely, the cows receiving as high as fifty to seventy-five pounds daily, and much of the ration is thus constituted. I believe there is nothing better for dairy cows, especially during the winter. They supply succulence which takes the place of the water or succulence which is found in green grass in June, at which time the cows do better than at any other time during the year.

Of course, it must be remembered that roots, containing as they do about ninety per cent of water to every one hundred pounds, must be fed in conjunction with feeds containing more dry matter, in order to provide for large and economical milk and butter-fat production. Clover-hay is very valuable in conjunction with roots; with a mixture of ground corn, ground oats and oil-meal or bran, fed in limited quantities, this makes up an ideal ration. **HUGH G. VAN PELT.**

Humane Dehorning

IN DEHORNING the young heifers, the most humane way is to wait until the horn just begins to appear through the hair. With a sharp knife peel off the outer covering of the horn, immediately underneath which will be seen a small white point a little larger than a pin-head. Hold the calf and rub this point with caustic potash, which can be purchased in sticks at any drug-store. Care must be taken not to burn the skin surrounding the horn, or else it is liable to cause a sore on the animal's head. If this operation is thoroughly done, the horns will never grow. If it is not thoroughly done, scurs are liable to grow on one or both sides. At best it renders the animal very homely in appearance and therein lies the objection of dehorning in this manner.

Many breeders prefer dehorning by sawing or clipping the horns off at a later date. This gives the animal more pain and is more difficult for the operator, and, on the whole, if the caustic is applied properly it should accomplish the purpose more easily. **H. G. V. P.**

Curing Crankiness

A WISCONSIN subscriber writes: "Please advise me how to treat a mare that switches on turning or any time the buggy tongue rubs her leg. She acts as if she would kick. She acts cranky when I harness her, tries to crowd in the stall and has tried to kick me when I put the crupper under her tail. She is five years old in the spring and is in colt. I feed her five ears of corn in the morning and about three quarts of ground corn and bran at night, and I only work her every other day or so, haul a little wood in from the woods and go to town once a week, about seven miles."

The fact that your mare is in foal makes it unwise to try very radical treatment on her at present, but several things can be tried now to advantage. If she kicks when you put on the crupper, have a cord reaching from the ceiling and when you are ready to harness her, hitch her to this with her head pretty high. A handy way is to have a cord of just the right length—or, better, two cords—with snaps in the end to snap into the bit on each side.

After harnessing, braid a few strands of hair on the inside of her tail into a braid about the size of a clothes-line and finish it in such a way that it will not come undone. Pass a shoe-string through this braid and tie it firmly to the breeching. This will prevent her from switching her tail and is so inconspicuous that few people will notice it. Keep this on until she forgets the habit.

Be as quiet as you can with this mare. You must, of course, be firm, but refrain from speaking harshly and from any undue or needless use of the whip. It is quite possible that she needs more radical treatment, but, if so, it must be deferred till after she drops her foal. In the meantime follow the suggestions here given and it may be that they will prove all that is necessary. The work you are giving the mare is all right if you do not hurry her, and see that the traces do not press hard against her sides. But while carrying a foal and working, too, the feed she is having is hardly sufficient. She is having enough corn, but the bran can be profitably increased. **DAVID BUFFUM.**

Death to Calves

A SUBSCRIBER at McMinnville, Tennessee, describes a calf which has had a watery discharge from the navel cord since birth, and which within the last two weeks has had swollen hocks. It is thin and weak, but still has a good appetite. The full description leads me to believe that the trouble is navel ill, caused by an infection before the umbilical cord became closed. Calves thus affected will oftentimes linger along for weeks, but in my experience I have never known one to recover. They are affected in different ways and oftentimes exactly as you describe—swelling of the hocks and a discharge from the umbilicus. When the calf dies, without doubt, if you cut open the hocks, you will find them badly infected and filled with pus.

There is nothing that I have ever found that would cure this disease and in view of the fact that the calf in question is only a grade, I do not believe it is worth while to try to save it, if it is still alive.

It is, however, very easy to prevent this disease. Of course, the stables and calf-pens should be disinfected and cleansed of the germ if possible, but this seems to be rather a difficult matter in itself. A more effective manner is to disinfect and tie up the navel cord immediately upon the birth of the calf. Take a strong string, well disinfected, and a two-per-cent solution of carbolic acid or a solution of any of the commercial disinfectants to be found upon the market, bathe the umbilicus well and tie the string tightly around the cord. This will prevent the entrance of the germs into the cord and thus prevent the disease. **H. G. V. P.**

The man who always talks to his horse as if it were a man will never talk to any man as if he were a brute.

If you will use a separate set of cans in which to carry the skim-milk back to the farm from the creamery, you may save getting bad bacteria into your milk.

A Tennessee farmer who brought a hog to market weighing 472 pounds was delighted to get ten cents per pound, and was further pleased because he had so little trouble figuring up what was coming to him—\$47.20.

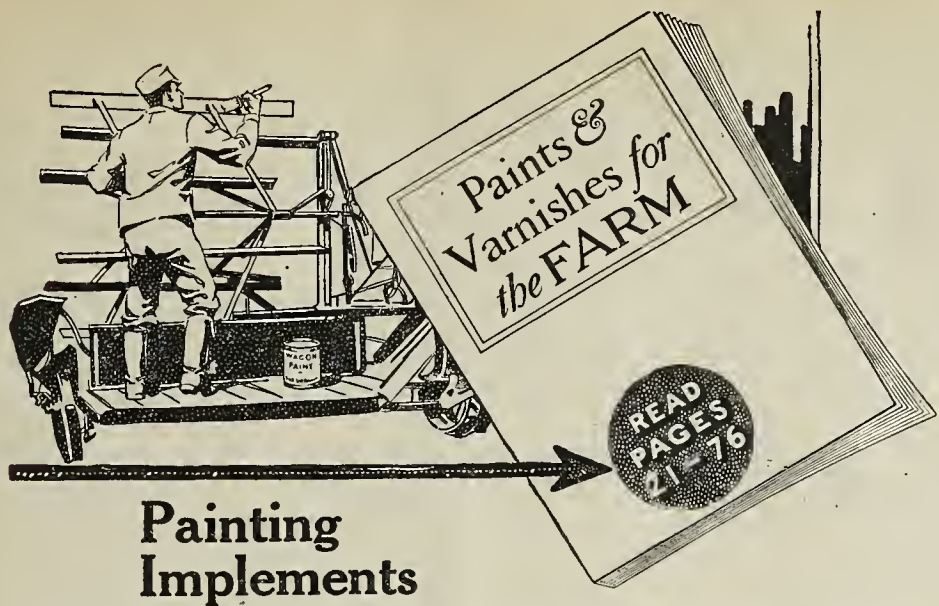

Painting Implements

FULL information regarding the best paint for use on farm buildings, implements and wagons is contained in this 116 page free book which every farmer should have. It explains the economy of using good paints and varnishes frequently and gives information regarding the painting of everything about the farm and the special paint for the purpose.

SHERWIN-WILLIAMS

PAINTS AND VARNISHES FOR FARM USE

There is a Sherwin-Williams' Paint for every purpose about the farm, and you are always sure of the right paint, no matter what your requirement. If you want to paint your barn, you have Sherwin-Williams' Commonwealth Barn Red; for your floors, Sherwin-Williams' Floorlac or Inside Floor Paint; for your wagons, implements and machinery, Sherwin-Williams' Wagon and Implement Paint, and every other conceivable kind of paint for every possible purpose.

This book gives a lot of painting information that every farmer should have, and shows how frequent use of good paint saves good money on the farm. Every farmer should have it—and we'll send it free to everyone who'll ask for it.

The Sherwin-Williams' dealer in your town can furnish you with the Sherwin-Williams' Paint for any purpose.

SHERWIN-WILLIAMS PAINTS & VARNISHES

Address all inquiries to The Sherwin-Williams Co., 691 Canal Road, Cleveland, Ohio. In Canada, to 639 Center Street, Montreal.

Elkhart Buggies

are the best made, best grade and easiest riding buggies on earth for the money.

FOR THIRTY-SEVEN YEARS

we have been selling direct and are

The Largest Manufacturers in the World

selling to the consumer exclusively. We ship for examination and approval, guaranteeing safe delivery, and also to save you money. If you are not satisfied as to style, quality and price you are nothing out.

May We Send You Our Large Catalogue?

Elkhart Carriage & Harness Mfg. Co. Elkhart, Indiana



There's Money in Lumber

AMERICAN SAW MILLS

Make most money because they do best work in quickest time with least power and smallest crews, owing to their simple construction and improved, patented devices. Portable and stationary. All sizes. Variable Friction Feed, Combined Ratchet Networks and Quick Reeder and other superior features. Free Catalog and Prices will interest you. Lists our complete line of wood working machinery.

American Saw Mill Machinery Co. 130 Hope St., Hackettstown, N. J. 1676 Terminal Building, New York

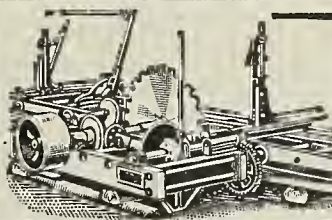

It is to your advantage to mention Farm and Fireside in writing to advertisers. Farm and Fireside folks get the very best attention.

GASOLINE PUMPING ENGINE

It costs about ONE CENT AN HOUR to pump water with this engine. If your time is worth more than a cent an hour you cannot afford to pump by hand: It will raise 32 barrels of water per hour to an elevation of 25 feet, 10 barrels to an elevation of 100 feet, or proportionate quantities to other heights.

This engine can be connected to "any old pump" in 30 minutes. After you have watched it pump water for five minutes you will wonder how you ever got along without it. The longer you have it, the better you will like it. It is right on the job all the time. A turn of the fly-wheel and it is off. A child can operate it. The ladies often start it to pump a pail of water. They rest while it works.

\$37.50
F.O.B. Chicago

It is shipped complete with walking beam, supporting frame and everything ready to set it up in complete working order, except three stakes for driving in ground.

Next to a windmill, this is the most economical outfit for pumping. We are selling many thousands of them every year, but our sale of Aeromotors is still increasing.

A PULLEY for running cream separator, churn, washing machine, ice cream freezer, grindstone or other light machinery is furnished with this engine for \$1.50 extra.

If you need an engine for pumping large quantities of water for irrigating, watering large herds of stock, or for other purposes, our Heavy Back-Geared Pumping Engine for \$100.00 is just the thing you have been looking for. It will raise 125 barrels of water an hour to an elevation of 50 feet, or proportionate quantities to any height.

Our \$75.00 2 H. P. General Purpose Power Engine with Fluted Cooler is the best thing going. Larger sizes at proportionately low prices.

AERMOTOR CO.

2510-12TH ST., CHICAGO.

Friend Mule

BUT a short time ago a now wealthy farmer told me that he had never driven anything but a pair of mules until he was twenty-five years old. That, in a way, sums up the conditions in many farming communities years ago. Then, mules were used almost exclusively, and were worked with satisfaction.

Somehow or other, but a short time ago, many got the idea that the man who used mules was old-fashioned. Five years ago there were but two spans of them in our entire neighborhood, and whenever their owners went to town, they were received with so much "joshing" that the sons of the families refused to drive them and they were sold.

At present the mule is coming back to his own. Of late there is an unprecedented demand for them all over the country. Construction work in the West requires thousands. With this new demand many farmers are discovering that they let a good thing slip and now they are going after it.

Perhaps the most striking example of the value of the hybrid on the farm is shown in Wayne County, Ohio. This county has a reputation for turning out more finished high-class drafters than any other section in the country. Last year nearly six thousand fine animals



Safe, Sane and Serviceable

were shipped from the vicinity to Eastern markets. Horse-feeders around here have the reputation for fitting animals of the type which take prizes at the International. Here one would expect to find the drafter in his element.

But you find him in the stable, while most of the real farm work is done by mules. It is a curious sight to go into a stable of the finest drafters that money will buy and to see the harness put on mules. But the horse-feeder says that a good pair of mules will outwork a pair of horses and feel like doing another day's work when they come in at night. They can be handled more easily in the field, often only a single line being used. There is no bother about shoeing and sore shoulders. Finally they say that mules require less currying and will do a given amount of work on a shorter allowance for feed.

All that seems like a good array of argument, but it must not be thought that mules are cheap. A pair of mules costs far more than a span of horses of the same weight. It is seldom that a really good pair sells for less than four hundred and fifty dollars, while a fancy pair sells still higher. Five hundred and fifty dollars was refused for the pair to which the one in the illustration belongs.

The meanness of the mule is proverbial. Be it enough to say that the old idea is exploded and that the ordinary mule does not live up to his reputation. Many employers are beginning to call the hybrid the "hired man's horse," for in many cases where valuable horses might be ruined by carelessness, the mule solves the problem. CLYDE A. WAUGH.

Driving Up the Cows

INSIGNIFICANT as the act may seem, there's a right way and a wrong way to drive up the cows, and many farmers choose the wrong way.

Going after the cows on foot is a waste of time and energy, but is preferable to putting a boy on a horse, to gallop them up with a whip and a shout, which is sure to cause worry and a loss of flesh and milk.

We often see the yelping dogs sent after the milch-cows. Only the other day we saw a boy on horseback, going pell-mell on this errand, the dog joining in the chase with bark and bite. If that lad's father did nothing to check this business, he doesn't deserve any more profit than he secures from his herd.

But there is no necessity of driving up the cows at all. Teach them to come at your call, by always giving them a little treat when they come up—a little grain, some fresh vegetables, a lump of sugar, a taste of salt, bran or anything they relish. They are quick to appreciate such kindness and soon it will only be necessary to call when you want them. They take their leisure in coming; and the easy gait, the absence of excitement and the pleasant anticipation of kindly treatment, all combine to stimulate the milk-flow. M. A. COVERDELL.

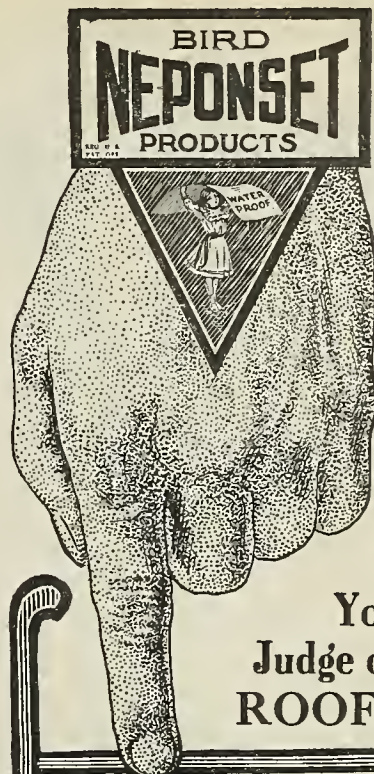

We Make You the Judge of our ROOFING

OUR OFFER: When you see your building, if you are not satisfied tell us and we will send you a check for the full cost of the roofing and the cost of laying it. Back of it all, if any BIRD NEPONSET PRODUCT ever fails because of defective manufacture we will replace it. If a broader guarantee than this could be made we would make it.

PAROID is sold by proof not promises. Let us show you a PAROID Roof—near you—that has been on for years, that has stood all kinds of weather. Judge by the roof itself. Judge by what the owner says.

Roof your buildings with PAROID, PROSLATE or NEPONSET RED ROPE ROOFING according to the nature of the structure, then give your verdict.

If you are not convinced that BIRD NEPONSET ROOFINGS are the most slightly, substantial, smooth laying roofings, say so and get your money back. If you find, years after, that exposure to the weather brings out some defect in manufacture, say so, and we will replace any such article.

We make the offer because our experience has taught us how to make a roofing that will look right at the start and wear right to the end.

You are as safe in buying BIRD NEPONSET PRODUCTS as we are safe in making this extraordinary offer. Every thing connected with BIRD NEPONSET PRODUCTS we make ourselves—the felt, the saturation, the coating, and even the rustproof cap and nails.

Are You Building or Repairing?

Our Building Counsel Department, experienced in the construction of every kind of building, is placed at your disposal. Write us particulars of any work you have in hand. Our suggestions or advice are offered free of charge. It may save you many dollars.

If your dealer does not carry BIRD NEPONSET PRODUCTS write us.

F. W. BIRD & SON

Established 1795

Main Mills and General Offices
28 Neponset St., East Walpole, Mass.
New York, Chicago, Washington, Portland, Ore.
Canadian Mills and Office: Hamilton, Ontario
Winnipeg Montreal St. John



BREEZE 7 Handsome Models \$275

Travel the worst roads with ease and comfort And Up SEND FOR CATALOG "U" The Breeze is strong, simple, speedy and safe. Best motor vehicle built for country roads—mud, deep sand or high hills. 13-18 H.P. engines. Lowest cost of upkeep. Least tire trouble. Handsomely finished. THE JEWEL CARRIAGE CO. CINCINNATI, OHIO

NEWTON'S HEAVE

COUGH, DISTEMPER AND INDIGESTION CURE
The Standard Veterinary Remedy. 20 years sale. Send for booklet.
SAFE TO USE
BEST CONDITIONER
Makes the horse sound, stay sound.
DEATH TO HEAVES
The first or second \$1.00 can cures. The third can is guaranteed to cure or money refunded. \$1.00 per can at dealers, or express prepaid. THE NEWTON REMEDY CO., Toledo, Ohio

BROODER
WITH THE **SURE HATCH**
60 DAYS FREE TRIAL
During this month we will send a brooder for actual half price to every person ordering a
Sure Hatch Bonded Incubator
This is the only incubator guaranteed and backed by a \$1,000,000 surety bond of the Bankers Surety Co., Cleveland, Ohio. We pay the freight.
SURE HATCH INCUBATOR CO.
Box 66, Fremont, Nebr.



Hatch Chickens By Steam
The most satisfactory incubators on the market are the Wooden Hen and Excelsior. They not only solve every problem of heat, moisture and ventilation, but hatch a chick from every fertile egg. The simplicity of construction and economical operation of the
Excelsior Incubator or WOODEN HEN
make them the most popular incubators—run themselves. Send for free catalogue on growing Incubator Chickens, for a free colored views.
GEO. H. STAHL
Box 5-W, Quincy, Ill.



At Last, the Perfect Incubator
100 EGG INCUBATOR \$7.00
100 Chick Outdoor Brooder 5.00
BOTH, FREIGHT PAID \$10.00
The Advance—Took 20 years to perfect. Thousands now making money with \$10 outfit, raising for market—breeding—selling. Copper tanks, double walls, self-regulating lamp and thermometer complete. Its equal for the money does not exist. Order direct, or full description Free for postal.
ADVANCE MFG. CO.
Box 35, Dayton, Ohio.



90% Hatches
from the Cyphers—in every country and climate—for old-timers and beginners. For you.
CYPHERS INCUBATORS
and Brooders are non-moisture; self-ventilating; self-regulating. Write for 160-page Catalogue. Address Nearest City.
Cyphers Incubator Co., Department 72
Buffalo, N. Y.; New York City; Chicago, Ill.; Boston, Mass.; Kansas City, Mo.; Oakland, Cal.
STANDARD CYPHERS INCUBATORS
First Profit—Hourly!



\$7.55 Buys Best 140-Egg Incubator
Double case all over; best copper tank; nursery self-regulator. Best 140-chick brooder. \$4.50. Both ordered together \$11.50. Freight prepaid. No machines at any price are better. Write for book today or send price and save waiting. Satisfaction guaranteed.
BELLE CITY INCUBATOR CO., Box 100, Racine, Wis.

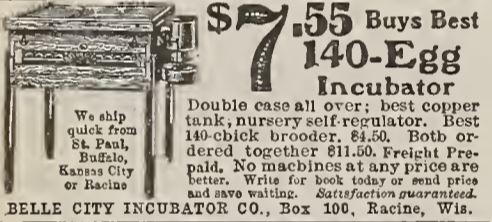

POULTRY PROFITS DOUBLED
If you want \$2 profit where you now get \$1, either from eggs or poultry for market, simply send us your name and address and let us tell you the real poultry secret that has doubled the profits of poultry raisers. Its the only real way to poultry success. Make every fowl a profit earner. Write at once for this information when you have 3 fowls or 300. It's free to you.
Blanke & Hawk Supply Co., 122 Blanke Bldg, St. Louis, Mo.

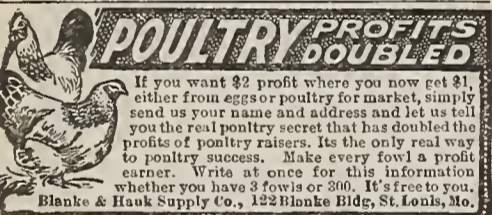

\$7.50 For 120-Egg Hatcher, Delivered
Improved; ideal; metal-covered. Safest, surest made. Other sizes east of Missouri River and north of Tennessee. Write for delivered price beyond. FREE—Guide to Poultry Profits, big book.
J. W. Miller Co., Box 31, Freeport, Ill.



Breed Prize Winners
We have the stock at right prices—all leading varieties; 100 pens. Write us. Booklet on "How to Raise 48 Chickens Out of 50 Hatched," 10c; Poultry Paper, 1 year, 25c; Catalogue Free.
ROYAL POULTRY FARM
Dept. 180, Des Moines, Iowa



FOY'S BIG BOOK, MONEY IN POULTRY
And Squabs. Tells how to start in small and grow big. Describes largest pure-bred Poultry Farm in the world and gives a great mass of useful information about poultry. Lowest prices on fowls, eggs, incubators and brooders. Mailed for 4c. F. Foy, Box 10, Des Moines, Iowa

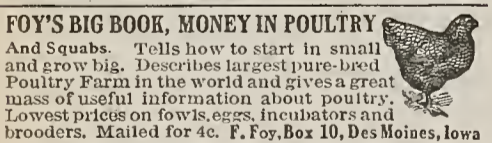

Chicken Business There's Fortunes in It
Get Busy. We start you. Most successful Poultry Farm. Thousands to choose from. Buy Eggs for Start. Low prices on fowls, eggs, incubators, etc. Big illustrated, valuable book, "Profitable Poultry," sent for 3 cents.
BERRY'S POULTRY FARM, Box 20, Clarinda, Iowa.



It is to your advantage to mention Farm and Fireside in writing to advertisers. Farm and Fireside folks get the very best attention.

"BREGO" Freight Prepaid
Rubber Roofing Don't think of using any kind of roofing till you test sample of old reliable Guaranteed "BREGO." Why pay more? Investigate, and you will order here today.
BOOK AND SAMPLE Free
Book proves and shows testimonials of Brego Service. Waterproof and fire-resisting qualities. Cement and nails free. Write today.
The Brees Bros. Co.
Roofing Dept. 24, Cincinnati, O.



Practical Poultry-Raising

Sunflowers for Poultry

SUNFLOWERS is one of the best crops the poultryman can raise. The sunflower has the advantage of not taking up much room on the ground, and giving a fine shade, aside from its feed value. The plants grow prolifically in nearly every state, and their culture is not confined to this side of the water.

In the summer the poultry can be allowed to run among the shady rows out of the sun's heat in the middle of the day. It makes one of the finest shelters for the young ducks that can be imagined. The seed is planted early in the spring and does well in a rather sandy soil or light loam. Seed should be planted in rows about forty inches apart and about one to three feet apart in the row, according to how high the stalks are wanted to grow. The sunflowers will hold their shade-producing qualities until they have been bitten by the frost and the leaves begin to drop.

One of the beauties of feeding sunflower-seed is that the chickens will harvest it themselves. The tops or blossoms are cut as soon as they are ripe, as sparrows are especially fond of the seed, and if left on the stalk until dry it is easy for them to extract the seed before the usual time of harvesting comes. There is little difficulty about keeping sunflower-seed if the heads are dried out after gathering in some place where the air circulates freely and where rats cannot get at them. The seed must be kept from freezing until it is thoroughly dry. After the heads are cut and have dried enough so that the seed can easily be removed by the fowls, whole heads are thrown to the chickens for them to work at.

Poultry like sunflower-seeds as well or better than anything that I ever feed them, and there is never sunflower-seed lying about the coop. One can not blame the fowls for liking it, as about the only thing that keeps the seed from being eaten as human food is the difficulty of cracking the seed.

I have never kept track of the amount of seed I have raised on a small strip, but the North Carolina station claims the astonishing yield of sixty-five bushels per acre of the seed. Mammoth Russian sunflower-seed weighed twenty-six and seven tenths pounds per acre, while the Black Giant produced thirty-two pounds.

The Corn and Sunflower Combination

More sunflowers and corn are planted together in the Eastern states than there used to be. The two grow well together, as the conditions that favor one also are congenial to the other. They both call for much sunshine. The sunflower-seeds are mixed with the corn in the planter, the aim being to plant the corn grains about one foot apart, and to use about three pints of sunflower-seed of the Mammoth Russian variety on each acre of land. As one of the seeds is much lighter they should be stirred frequently so they will feed evenly. The crop is cut with the corn-harvester, the large cutting-box doing the best work. The combination is grown for the silo and the two crops are run through the ensilage cutter at one time. Some of the growers complain that the heads of the sunflowers are heavy to handle, but the increase in protein over the clear corn product is enough to pay for the harvesting of the sunflowers.

The analysis of fresh sunflower-seed is given as protein, 16.3 per cent; carbohydrates, 21.4, and fats 21.2; while the analysis of dent corn is protein, 10.3 per cent; carbohydrates, 70.4, and fats 5. The air-dried seed has a little less fat and protein.

For poultry, a few rows of sunflowers can be raised close to the fence around the yards where there would likely be nothing else grown, on so small a space that they will apparently be raised only for shade; but there will be quite a bit derived from them in the form of seed.

EDWY B. REID.

Indigestion in the Flock

A MICHIGAN subscriber writes: "About two months ago my White Wyandottes began to show signs of diarrhea. The droppings are whitish color and very watery looking. They seem to be healthy otherwise. I feed bran and ground corn in morning with a little salt all mixed with warm water, also put a patent poultry food and black pepper in their mash, and give a little corn at noon, perhaps three or four kernels apiece. In the evening I feed corn, about one quart to twenty-six chicks." As this is not cholera—in which the

discharge is, as a rule, white, due to blood breaking through the intestines devoid of the red corpuscles—it must be due to one of these causes—typhilitis bacteria or indigestion, both of which can cause a congested liver. Such a liver throws too much work upon the kidneys, hence this abundance of kidney secretion, which is always white or white slightly tinged with yellow.

My own idea is that indigestion is at the bottom of the trouble, and in time the fowls would show sickness and die. Give each affected fowl two grains of calomel to begin with. Follow this with from one half to three-fourths of a teaspoonful of Epsom salts to each—give this, say, from four to six hours after the calomel. For a week afterward, with each mash, give enough soda so that each fowl gets about four grains a day. This is the only sure remedy known for anything causing liver congestion and kidney overwork. If bacteria be the cause, the calomel rids the system of them.

You are feeding too much corn. Give the bran dry and feed wheat or oats in the evening. Shut off on the pepper and on patent food, unless—for the latter—once a week.

I. M. S.

Spring Poultry Pointers

Early and well-matured chicks should not be fed with the late-hatched ones, as they will crowd them out, eat up their feed, trample on them and otherwise use them up. This is one of the reasons why people have poor luck with late-hatched stock.

Young chicks, on starting their first feathers, show signs of feebleness and are droopy. Change their diet, give them range and exercise, and furnish better shelter. A little sulphur in their food will be beneficial.

Rapidly-growing chicks frequently have what is known as leg weakness, sitting upon their hocks most of the time, and when walking they are weak and tremble in the legs and knees. With bone-meal added to their feed, a little tincture of iron in their water and clean, well-ventilated coops they will usually get strong and active again.

Eyelids of young chicks watering and sticking together is generally caused by their taking cold and approaching a roup condition. The drop of temperature morning and evening leads to this. Young chicks if a little hungry will stay out from under the hen too long and become chilled, while well-fed chicks will immediately seek the care and warmth of the brood hen.

Watch for lice and mites, and keep them down and out. A lousy hen cannot lay eggs, nor can young chicks grow if covered with lice. More losses are caused by lice than any other cause. Spray your houses, nests, perches and brood coops often with a good liquid louse killer or kerosene.

At last the farmer has come to understand that if he wants his poultry to pay, he must get rid of the mongrel stock and install thoroughbreds and the old dilapidated roosting-shed must be replaced with a warm and comfortable hennery. They can be no slipshod work in this business.

A. E. VANDERVORT.

All About Gapeworms

IT IS wonderful what ideas some people do have about the gapeworm—the syngamus trachealis for long if you want to call it that. Its history is well known to poultry scientists and yet I heard a woman say the other day she knew they hatched from the big lice, because every chick she found with the gapes also had lice. As some poultry writers speak of the gapes as a disease, in that case that woman's chicks had two diseases—so called. But as all who raise chicks should know, gapes is no more a disease than lice, and while the gapeworm comes from an egg just as lice do, the egg of each produces only its own kind.

The gapeworm is one of the strangest living things on earth. It is not a worm, but two worms, male and female, the male being much the smaller and growing out of the female's body just below the head. Spread them out under the weakest sort of a microscope or even a reading glass and you can see them plainly, round sucker mouths, circulatory apparatus and the unhatched eggs. Tiny stickers along the body hold them close to the windpipe where, spread out like the letter Y, they suck away the

chick's life blood as well as finally strangling it to death.

They live in the ground, and old chip-yards are full of them. They infest little pools of water. They are often found under the floor boards of a coop and close outside—in waiting for the chicks.

The life cycle of these double worms is about nine days. The female, when fully matured, is slightly over a half inch in length, the male not quite one-fourth. When the worms have completed their destiny they pull apart, letting loose the eggs, then die. I have found them dead in the chick's trachea.

The chicks pick up both worms and eggs from the ground and drink them from water pools in the yards. It is claimed that the eggs will hatch in the crop. Of this I cannot say, but this I know by examination, the eggs let loose in the windpipe will hatch, for I have seen, under the microscope, a drop of blood taken from a chick's throat, swarming with them. Experiments made time and again show that they reach the crop first, in the worm state, anyway, and from there those not hurried into digestion make straight out and for the windpipe—an easy matter.

That fishing-worms do hand some of them over to chicks, I know. Gape-worms will, if possible, enter a coop where chicks are kept from the ground. They nearly disappear in hot dry weather. Older fowls do have them. Crows and pheasants die of them. I saw a turkey-hen once with her throat full of them, also a pullet. The older chicks that quirk and sneeze so at night have them. But the older the chick, the less harm is done.

Gapeworms are easily killed. This is why turpentine, garlic, onions and even certain disinfectants kill all present in the crop. Once let them reach the windpipe and medicine cannot reach them, for anything injected into the windpipe will often kill the chick than save it.

Three doubled and twisted horsehairs—no less than three—is the best remedy. Wire gape-extractors or blue-grass hurt a chick's throat and cause too much bleeding. Anybody can learn to gape chickens. I have gaped over two hundred in a season. If chicks get the trouble at a week old, even gaping will not save them at times, but chicks at two weeks old and over need not be left to die. Gapes is the curse of my poultry premises. Lime and sulphuric acid have decreased, but never entirely eradicated it. I keep the same horsehairs from year to year, stuck in a bottle half full of turpentine. It's too much trouble to hunt up horsehairs every time a chick needs to be gaped. Then some hairs will not stay twisted.

Sit on a low step, and with a good light on the chick's throat, hold its feet tight between your knees; pull up on the throat with the left hand as you hold the mouth open with two of the left-hand fingers. Then you can look into the windpipe and see the worms. If the chick seems exhausted after two or three trials with the horsehairs in its throat, blow in its mouth and wet the top of its head.

I. M. S.

More About Guineas

IT SEEMS that there is quite an interest in guineas and many inquiries for further information about them are coming in. The eggs are smaller than the chickens and the shells are harder so that eggs for hatching are safely shipped for long distances if well packed. Persons having a surplus of either stock or eggs might make it pay to advertise their stock for sale.

Guineas mate off in pairs if there are as many male birds as females in a flock; but from three to five hens can be mated to one cock, which is more economical. Furthermore, all the hens mated to a cock will usually lay in the same nest which increases the chances of finding the nest and also avoids so many nests being hid about the farm. Guineas take a wide range if allowed the run of a farm, but will return to their usual roosting-place at night.

It is not necessary to dispose of the male birds hatched from a sitting of eggs and go to the expense of purchasing new ones, under ordinary conditions. Of course, new blood should be introduced into a flock occasionally, but the eggs from a sitting usually represent the blood of several birds.

A. J. LEGG.

Ducks are seldom penned in small numbers for breeding, but are usually mated about thirty ducks and six drakes in one flock.

Farm Notes

Human Corn-Shellers Best

ONE of our neighbors was much criticized a few years ago because he advocated hand shelling of seed-corn, but to-day many of our best farmers agree with him, especially those who make a specialty of raising fine corn to supply a seed trade.

That man tried to tell his neighbors fifty years ago how corn shelled by machinery would rot in the ground, under unfavorable circumstances, when hand-shelled corn would go through in fair shape. But shelling on a sheller was so much easier that few people paid any attention to the argument. Now, as the question is studied to the minutest point, it has been found that this, in large measure, is true. Not only is this phase of shelling important, but there is another, that of purity. Corn needs the closest attention, to prevent cross-pollination—or, to be plain, to keep the

losses of the soil due to bad farming, and the farmer who sets fire to a broom-sedge field is doing what he can to counteract her efforts to restore fertility. It would be much better to run the mower over the field just about the time the broom-sedge stem has reached its full height, but before it gets hard. Broom-sedge straw rots more readily if cut at this season, and if it is left on the soil, it will act as a mulch and save not only fertility, but moisture. The clipping will also discourage the growth of weeds and running briars.

A. J. LEGG.

Broom-sedge isn't the only good thing we burn up. Stubble, straw, leaves and corn-stalks send up their smoky protest to heaven all over the country against being burnt. The editor of this paper spoiled the fertility of an Iowa corn-field in his boyhood by burning off its corn-stalks. He wanted to see the furrows turn over clean and black, and the stalks were in the way. It took some years to put back what his "neat farming" robbed the soil of. Vegetable matter ought not to be burned unless it is infected with disease or noxious seeds.

Ridding Land of Dewberries

J. B. B., of Wetzel County, West Virginia, writes me that he has a six-acre field now overrun with dewberry-briers which he wants to get into grass. His plan of running the disk over the field before plowing is a good one, but I do not think fall is the best season to do it.

The tips of the vines take root in the fall and spread like raspberry-vines. I have had better success plowing the ground in the spring. I would cut the vines with the disk after the leaves begin to come out, leave them a few days to wither, then turn them under, pulverize the soil well and sow an early variety of cow-peas. I would drill them in with a wheat-drill and one hundred and fifty to two hundred pounds of a good grade acid phosphate and potash with them. The peas should be sown about June first in this region, most seasons. New Era peas would ripen by the middle of August. Hog the peas off or pasture with cattle, work the land up well and sow to wheat with grass in the fall and to clover in the spring. Or, if buckwheat does well in that locality, it might be a good plan to turn the wheat-stubble after wheat harvest and sow to buckwheat, timothy and clover. Grass and clover do better here sown with buckwheat in July. Then mowing the grass will discourage the growth of running briars and hold them in check.

I prefer the cow-peas to corn, as the peas enrich the soil, which is desirable where the later crop of grass is the main object sought.

A. J. L.



How the Writer Shells His Seed-Corn

pollen of one variety from getting on the ripe silks of another variety, which will cause a cross—a mixture.

Many farmers fail to note the dust-like clouds of pollen over their fields in tasseling-time. This pollen-laden breeze often ruins a near-by field of another variety, so far as the worth for seed is concerned. The corn-breeder often has a tough problem to keep his pure-bred corn isolated from other varieties. His neighbor often enough insists on planting yellow corn just over the fence from his pure white corn. Then, too, insects from fields quite a distance away often come flying, dusty with pollen, and strike a silk which is in a receptive condition.

The writer shells each ear by hand for his own planting, carefully watching for any kernel showing even the slightest trace of yellow, all such being discarded. However, when shelling yellow corn, the mixed kernels should be removed before shelling, as the mixed kernels show only a white cap, which is hard to detect when shelled. Then, too, shelling each ear separately gives one a chance to discard ears showing grains with brownish-tinted tips, also those showing a kernel of a shape off standard.

The best bred corn to-day has one fault, that of setting an occasional grain between the rows. The writer thought this might be eliminated by taking out this kernel, and possibly the ones surrounding it, but the past season's work in this direction shows no decided change. Yet I think a few years of carefulness along this line will bring marked improvement.

Often improvements are possible by this single-ear hand shelling. For slipshod corn-raisers the method may be "entirely too tedious and slow," but all the good things in plant-breeding come slow.

OMER R. ABRAHAM.

Fertility in Smoke

IT is a common thing all over this section to see a sheet of fire running over the pasture-fields. Broom-sedge burning is in season at any time during late winter or early spring when it is dry enough.

The old dry broom-sedge is burned in order to get it out of the way of the young, tender growth, but the practice is not well-considered. There is a large amount of humus-making material sent up into the air and lost to the soil which produced it. Nor is this all—the manure remaining on the ground from the previous year's pasturing is also lost. After the flame has passed on and left a charred stubble, there will still be curls of smoke here and there that on examination are usually found to come from dried animal excrement burning. The fire will not go out until all this burns.

Broom-sedge is a natural wild grass that covers old worn-out fields. It is a weak effort of Nature to repair the



3 HARD HITTERS

Here are Three Hard Hitters from our 43 different models. Every gun made in The Factory of Precision, be it Rifle, Shotgun or Pistol, hits hard and true.



FAVORITE No. 17.
List Price \$6.00

There are more Stevens Favorite Rifles sold than any other Rifle Model in the world, because they are more accurate than Rifles of other makes that sell up to fifty dollars.

Used by boys because of the price—used by men because of Bull's-Eye Accuracy. We make 1,800 Favorite Rifles a week—that's why we can sell them at the price we do and make them by the same methods and with the same skill used in making our heavier Rifles that hold World's Records.

This rifle is guaranteed by the STEVENS GUARANTEE, which is a guarantee that binds.

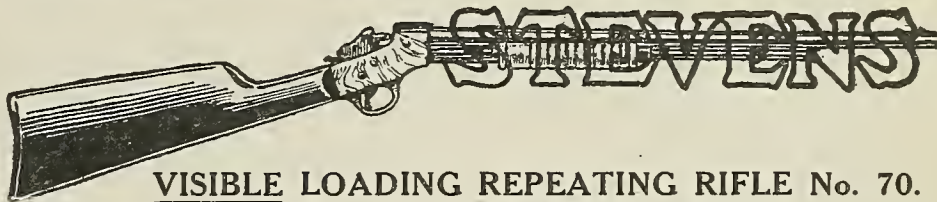

VISIBLE LOADING REPEATING RIFLE No. 70.
List Price \$8.00

You have fifteen quick shots without reloading—twelve if you use .22 Long Rifle cartridges. Two Models: One takes .22 short only, the other takes any one of three cartridges—.22 short, .22 long and .22 Long Rifle, but the greatest accuracy is obtained by using .22 Long Rifle exclusively in this model.

You SEE the cartridge go into the chamber, you KNOW when the rifle is loaded and ready to shoot.

This model is used extensively throughout the country for exterminating such pests as gophers, weasels, rabbits, rats, squirrels, raccoons, woodchucks, hawks, hares, crows, and other crop thieves. The rifling in this barrel is so precise that the same cartridge will shoot straighter and with greater penetration than it will in any other rifle.



REPEATING HAMMERLESS SHOTGUN No. 520.
(Solid Breech) List Price \$27.00

You cannot buy another Repeating Shotgun at any price that has all these advantages:

1. The safety of a solid steel wall between you and the shell.
2. The Non-Balkable feature which makes it impossible for the quickest hand to clog it.
3. Easy working mechanism that with Non-Balkable feature gets in six shots with lightning-like rapidity.
4. Perfected balance and racy lines which make this gun a Natural Pointer.

Young shooters get into the "sure shot class" and old shooters improve their scores quicker with a Stevens than with any other Repeater known. The balance and general finish of the gun make this possible.

The next time you are near your Sporting Goods Dealer or when you pass your Hardware Store ask them to show you the Stevens Line and if they do not carry the particular firearm you would like to see, write us and we will ship same to you direct, EXPRESS PREPAID, on receipt of List Price.

What Kind of Shooting Are You Interested in? SHARPSHOOTING, TRAP SHOOTING OR HUNTING?

Write us which one and we will send you a detailed letter giving you invaluable points and hints on either target work, trap shooting or in hunting big or little game. Furthermore we will send you by return mail, FREE, our 160-page Gun Book with 209 illustrations telling you all about Rifles, Shotguns, Pistols and Rifle Telescopes—the largest assortment of high grade firearms in the country all made under one roof.

J. STEVENS ARMS & TOOL COMPANY, Dept. 734, CHICOPEE FALLS, MASS.
THE FACTORY OF PRECISION

WEIGHT DIFFERENCE?

Going to buy a fence? Then beware of the mistake of counting waste weight as strength. Study carefully those points where wire meets wire. In all fences with wraps, ties or clamps remember that every ounce of wire in those wraps, ties or clamps is waste wire, dead weight. These bunglesome holding devices add nothing whatever to strength, but detract from appearance, effectiveness and durability. You know that you have to pay for that waste weight—also you pay freight on waste weight.

Now look at the

"PITTSBURGH PERFECT" FENCE

Not an Ounce of Waste Weight!

Wires electrically welded at every contact point—the weld is even stronger than the wire. The selling price of any other fence made of the same gauge (size) wire as the "Pittsburgh Perfect" Fence is greater than the selling price of the "Pittsburgh Perfect". Judge the strength of a fence by the size of the wires. Get a fence with stay wires as large as line wires—weaker stay wires make a weaker fence. Every wire in the "Pittsburgh Perfect" is of open hearth steel, galvanized by our improved process. Insist on seeing this fence. It is made in 73 different styles for every fence purpose.

Your dealer sells it. Write for free catalog.

PITTSBURGH STEEL CO., Pittsburgh, Pa.



AGENTS \$30 A Week

NO EXPERIENCE NEEDED—We show you everything—help you get started. Only honesty and industry required. Just show and take orders—anyone can do it. A beginner should make 75 sales out of every hundred calls—\$75 made. You can triple your income by just spare time work—a nice, clean, good clothes job and big money selling the

THOMAS FIRE EXTINGUISHER

The easiest, quickest, fastest selling article ever offered the public. One to six sold to a customer. People can't resist buying it. You can't blame them. THINK OF IT—A FIRE EXTINGUISHER WITHOUT WATER. A child can use it. Always ready. Acts instantly. Absolute protection from horrible fire accidents in homes, schools, factories, mines, stores, office buildings, theatres, etc. AGENTS WANTED IN EVERY COUNTY. Enormous sales and big profits possible. New to the market, stores can't get it. Full particulars, best talking points, fastest selling plans, etc., FREE. Write now.

THOMAS MFG. CO. 3346 Wayne St. DAYTON, O.

Going Fishing?

Then You'll Need Fishing Tackle—Here are Three Fine Assortments

Number One

Contains 34 Pieces of finest quality fishing tackle, assorted as follows: One Electric Wooden Minnow Blended Rainbow; One Double Propeller Glow Spinner; One Weedless Casting Spoon, Nickel Convex, Copper Concave; One Carleton Spinner, Polished Nickel both sides; One Original Casting Spinner, Nickel Convex, Copper Concave; One Original Casting Spinner, White Enamel over all; One Hercules Cable Wire Leader, 36 inch; 1/2 Dozen Cincinnati Bass Snelled Hooks, Double Gut, Gold Medal Quality; 1/2 Dozen Sproat Snelled Hooks, Single Gut, Gold Medal Quality; 1/2 Dozen Carlisle Snelled Hooks, Single Gut, Gold Medal Quality; 1/2 Dozen Connecting Links, Nickel Plated, assorted sizes; 1/2 Dozen Patented Bass Casting Swivel Sinkers, assorted sizes.

Number Two

Contains 21 Pieces of excellent, durable tackle, assorted as follows: One Magic Wooden Minnow, Aluminum finish; One Furnished Line, near silk line, Float, Hooks, etc., complete; Ten Carlisle Filled Point Ringed Hooks assorted; Six Carlisle Hooks, tied to silkworm gut, assorted; One Hank of 15 feet best quality braided line; Two Clincher Grooved Sinkers, assorted.

Number Three

Contains 15 Pieces, assorted as follows: No. 2265 assortment consists of one good quality 15-foot Draht Line on Fancy Jap. Bamboo Winder, complete with Hooks, Sinker and three-color Enamelled Adjustable Float, one extra 15-foot Linen Finish Line, four extra Ringed Carlisle and Kirby Hooks, assorted sizes, and six Split Shot Sinkers.

Our Offer

For only sixteen 8-month trial subscriptions to FARM AND FIRESIDE, at 25 cents each, we will send you, postpaid, Outfit No. 1, nicely packed in a box made expressly for this purpose.

For only five 8-month trial subscriptions to FARM AND FIRESIDE, at 25 cents each, we will send, postpaid, Outfit No. 2.

For only two 8-month trial subscriptions to FARM AND FIRESIDE, at 25 cents each, we will send, postpaid, Outfit No. 3. Send your orders at once to FARM AND FIRESIDE, Springfield, Ohio

Practical Farm Notes

Extra Intensive Gardening

THIS is the way I make a garden of my small lot twenty-five by one hundred and twenty-five feet.

In the twelve feet in front of the house I have my flower-garden with a sequence of crocus, hyacinths, tulips, roses and all choice flowers from early spring till Jack Frost settles the whole business. The house takes thirty feet, a grape-arbor ten feet, leaned to the back of the house, which leaves me a space seventy-three feet by twenty-one feet wide. The brick walk and a strip for flowers by the fence take the other four feet.

The first crop is three rows of rhubarb, twenty-one roots. By placing a box with the bottom out over each root, I find I can pull rhubarb several days earlier and twice the length of what I have grown without boxes, giving us plenty all summer and some to spare, which I sell to the neighbors for five cents a dozen.

Next a cold-frame occupies a place twelve by six feet. This I keep going all the time. Over winter, one half is full of lettuce-plants sown September 16th. I keep thinning them up to Christmas and there are thousands left. In the other half are three rows of parsley and about five hundred early Wakefield cabbage-plants sown September 16th which are ready to plant out by the end of March. A year ago last Christmas I planted between the rhubarb twelve of the strongest cabbage-plants I had, just for experiment, and they pulled through all right.

I used to cover the glass with canvas in sharp weather, but found that it was not needed. Cabbage and lettuce are three parts hardy, anyway. It is dampness, not cold, that kills them. Give plenty of air in fine weather; do not allow a drop of water to hang on the glass inside the frame. Four years ago I lost all my plants through covering the frame too close. They all damped off. Yet if it is covered with snow for two or three weeks, I never clear it off. After the snow melts away, the plants look so much better—it seems to preserve them. After losing my plants of four years ago, I gave seventy-five cents a hundred for the regular market plants and only saved half of them. Three years ago I planted out a hundred of my

own plants March 26th. Next morning there was three inches of snow, tips of leaves just sticking through. The day after the snow was gone they looked as if they had had an April shower on them, and I began cutting cabbage June 2d.

I always plant six rows sixteen inches apart each way, giving ninety-six cabbage-plants, and a lettuce-plant in every square, giving eighty lettuce-plants. I reckon that patch is worth ten dollars to me on an average for the one crop. By the first of August the same ground is planted with three double rows of White Plume celery—two hundred and ten plants, worth five dollars, making a total of fifteen dollars, besides a crop of radishes between the rows of celery, on a space of ground nine feet wide and twenty-one feet long. Our milkmen have often told me I grow more on my lot than some farmers do on two acres. I suppose it is the time I put in that counts.

After clearing my frame of cabbage-plants last year I transplanted one hundred and seventeen celery-plants (White Plume) into the six feet square just as an experiment for self-bleaching. Even with another twelve-inch board on top of the frame, making it twenty-two inches deep, by September the celery was three inches above the frame. I began using it right away, pulling every other root. September 18th I wanted the frame for sowing cabbage-seed so I stripped it all out and dug a hole thirty inches deep, two feet wide and packed the celery in straight and close, root and top just as it grew, and covered the hole with boards. It was the best celery we ever ate. All it needs when in the frame is plenty of washing-water every week and the frame is not wanted for anything else at that time.

Last year on April 16th I planted eight rows of dwarf peas fifteen inches apart, cleared them June 23d, replanted with four rows of bush limas two feet apart with radishes between the rows. On April 18th I planted four rows of bush beans, cleared June 28th and planted the same day four rows of Savoy cabbage, radish between; April 19th planted nine rows of onion-seed ten inches apart, pulled them August 28th and sowed early-turnip seed the same day. April 19th planted seven rows of early carrot ten inches apart, five rows of parsnips twelve inches apart and two rows of beets twelve inches apart; these three crops lasted all season. The space I have left I sow with radish and cress every other row, which I keep thinning out to fill in with tomatoes. The space at the head of the cold-frame bears lettuce and cucumbers. That finishes my cropping. They have nothing else to do but grow with the hurry-up attention I give them. I am a night watchman and I put all my spare time in the garden, so am never stuck for a job. I give my garden a good three-inch thickness of stable manure and trench it all over twelve to fourteen inches deep in December, and put on a good dressing of air-slaked lime and stir it in as soon as the weather is open for planting.

C. AKHURST.

We are all interested in any system by which the most is made of land. Mr. Akhurst here shows us how by extra-intensive culture he equals the Chinese and Japanese of whom Professor King tells. There is a lesson here for the farmer, as well as for the city-dweller. It is by such devices that Mr. Martin, of Nebraska, made himself well-to-do on a twenty-acre farm.

EDITOR.

Alfalfa-Growing in Colorado

IN PLANTING alfalfa-seed the soil should be well prepared. If it is to be planted on an old grain or sugar-beet field, a good disking, followed by a thorough harrowing, will put the seed-bed in good condition.

As the plant is tender until the second leaf appears, seeding should be delayed until danger of severe frosts is past. The seed should be put in with a drill, about twenty pounds to the acre, though some sow as much as thirty pounds, and a few as little as ten. Oats are usually sown with it as a nurse crop; but wheat is better, as it has less foliage to shade the young alfalfa. It is a good plan to cut the grain in the hay stage, especially in an irrigated country, as the alfalfa needs watering before the grain is ripe enough to cut.

The seed germinates quickly, from one to five days in germination tests.

The second year the field will be ready for business and should be cut when

about half the stalks show blossoms. Rake the same day and cure in cocks, stacking before it is dry enough to scatter its leaves badly. If the weather is damp, salt may be scattered over the hay when stacking. Keep the middle of the stack very solid and top off with a thick layer of old hay or wild grass. Weighted baling wire should extend from end to end and several times across.

The hay should be fed dry to cattle, but if it is a little dusty it should be dampened for horses. Young calves and poultry relish the loose leaves. If green feed is at a premium in the spring, turn the cows on it when it first comes up; in this case the cattle should be well filled up on hay before going to the field, and they should on no account be turned in before the dew dries or after a shower.

The field may be pastured in the same way in the fall if only two cuttings of hay are desired, or the second crop may be allowed to ripen for seed, in which case a good crop of fine-flavored, extra-white honey may be looked for if the farmer keeps bees. If straight hay is all that the owner wants, he can get three and sometimes four cuttings. Where seed is raised, the thrashings make good feed for loose horses or young cattle.

VARAH A. ARMSTRONG.

Growing Crops for Humus

MOVING onto this farm in September of 1908 and having but one horse and no implements, I had a neighbor put in an acre of rye, figuring that I would have pigs to eat it off the next summer. This acre of ground was about as devoid of humus as the big road, and although we had several good showers just before it was broken, it broke up very cloddy, some of the clods being as large as a peck measure and almost as hard as a rock. But by the next summer they had disappeared completely.

The rye barely came up before winter set in and grew very slowly in spring. Having given up the idea of getting the pigs, I plowed the rye under when it was in bloom; in places it was four feet tall, while on the poorest soil it was not more than a foot tall and thin on the ground. I harrowed and dragged till the soil was in nice shape and sowed three pecks of cow-peas and some millet. It made a quick growth and by September was in good shape to cut for feed, but I turned it under. Before doing so I spread five two-horse loads of manure on the poorest half of the acre.

While oat-stubble was so dry one could not plow it, this piece was moist and mellow, and harrowing and dragging put it in fine shape for another sowing of rye. Where the manure was spread, the rye was six inches tall by December and that on the naturally better soil which did not get any manure was two or three inches tall.

With that rye plowed under this spring and the piece planted to corn, I expect to get fifty bushels off the acre, which would not have produced five bushels of corn before the rye and cow-peas were turned under. I sowed one hundred and twenty-five pounds of a two-eight-six fertilizer with first crop of rye, but the other two crops had none at all. I would like to tell FARM AND FIRESIDE readers later on just how much corn I get from this acre of ground.

W. D. COLLINS.

Stopping the Washes

IN THOSE sections where spring rains are frequent and heavy the farmer is confronted with the necessity of filling the washes in his fields. How must this be done? It is unwise to haul out the manure-pile and dump it into the washes as some farmers do. This robs the soil of what naturally belongs to it and it accomplishes nothing, as the manure will be washed down the gullies into the branches and on to the rivers. Neither is it wise to pile the old straw-rick into the washes unless there are obstructions to hold it when a freshet is on. If stakes are driven across the gully at intervals, however, straw piled above them serves very well to catch the sediment. Brush and rocks also can be dumped in to hold the loose dirt. I have sometimes used old stumps very effectively. The point is not how much you can dump into the gully, but how much you can get to stay there.

A gully may often be stopped by the planting at its head and along its bottom of some vigorous shrub or tree which will catch the debris of the run-off and, when the evil is cured, may be removed if desired.

W. D. NEALE.



The Worst Rain Storm Cannot Affect It

THE soaking, driving, pelting, sleeting, down-pouring rains which rust and pin-hole tin and sheet iron roofs, rot and loosen shingles, wash away gravel, and crack the so-called "rubber roofings," make not the slightest impression on

REX FLINTKOTE ROOFING

It will withstand the fiercest "Weather-racket" you can imagine. You can absolutely rely on it. It is backed by a business reputation of over 70 years. If interested in roofing for your home, barn, shed or other building and want a roof of proven economy, send for our large, new book, "Storm Facts." It gives Facts! Yours for the asking.

FOUNDED 1837

J. A. & W. BIRD & CO.
24 India St., Boston, Mass.

AGENTS EVERYWHERE



Farm Notes

Building Up the Pastures

THE improvement and maintenance of permanent pastures on land that cannot be economically cultivated is an important problem. In the Old World, the grass crop has long been rated at its true value, and systematic methods have secured the maximum growth, until these countries occupy an enviable position in the live-stock world. We in America have followed a less intensive practice. Every year, however, sees an increased need of such improvement. We have the best of grasses for grazing and a sufficient variety to be adapted to almost any kind of soil.

Some make a great mistake by overstocking pastures. So long as this is continued there is not much use of talking improvement. The ground is robbed of its covering, the sun gets at the unprotected grass roots and shrivels them, while the soil moisture rapidly evaporates, leaving the surface baked to about the consistency of an oak plank. Personally, I prefer to divide such land into three lots and pasture each in turn, thus giving the grass a chance to grow and the cattle a frequent change. My plan is to renew one of these lots every three years. Each spring one lot is given a thorough harrowing, together with a light application of barn-yard manure, say five or six tons to the acre. This is where a manure-spreader is almost indispensable for spreading this small amount of manure evenly over the whole area; this gives much better results than when a large quantity is used, as would be necessary with hand spreading.

In seeding for pasturage, the purpose should be to so mix the different varieties as to secure a succession of grasses maturing at different times throughout the season. Moreover, the selection must be governed largely by the nature of the soil, the requirements of uplands being radically different from those of low-lying section lands. Here in Ontario, however, the following standard mixture has proved good almost everywhere: Orchard grass, four pounds; meadow fescue, four pounds; tall oat grass, three pounds; timothy, two pounds; meadow foxtail, two pounds; alfalfa, five pounds; alsike clover, two pounds, and white clover, two pounds, making a total of twenty-four pounds of seed per acre. This amount is, of course, intended for the first seeding, when establishing a pasture. As reseeding becomes necessary from time to time, only those grasses that are growing scant need be sown, and then only in such quantities as the circumstances demand.

Because of its extreme earliness and its ability to resist droughts, orchard grass has a decided value in any pasture. It thrives on almost any kind of soil, doing well on low lands and in shaded locations. A quick-growing aftermath is furnished, which is relished by stock, particularly horses and sheep. Close grazing will not hurt it and rather tends to reduce the bunched appearance that is characteristic of the plant. Its susceptibility to injury by frost will sometimes retard growth during the earlier part of the season.

Meadow fescue is essentially a permanent pasture grass, as it does not become well established until the third year. Like orchard grass, it commences growth early in the spring and will continue green, until late in the fall. It is not a poor-land grass, doing its best, on rich and fairly moist loam, though quite suitable to a variety of soils.

In dry districts and on light, sandy land the tall oat grass is perfectly at home. It grows throughout the season, stands drought and yields a good aftermath. Though it is somewhat bitter, stock eat it well. On low fertile clays and clay loams meadow foxtail should form part of the grass mixture. It requires about three years to become established, but under good conditions will sometimes maintain itself for twenty years.

Timothy, though popular, is not a first-class pasture grass in the same sense as most of the foregoing. It will not withstand close grazing and suffers severely from drought. Under the most favorable conditions it affords only a scant aftermath. During the early part of the season, however, it makes a good growth and is relished by all stock. On low-priced or low-grade pasture it pays to give it a place, as it will thicken the sward during the first year or two until the more permanent grasses are established.

Every pasture ought to have some of the clovers in it. They raise the feeding value of the forage, and are no

small factor in producing a heavier growth, through their ability as soil improvers. Of this family, alsike is best adapted to comparatively wet lands; white clover generally does well on rather poor upland soils, while alfalfa prefers an intermediate location.

It will be seen that to build up a pasture into an asset of real value, it is good economy to study the characteristics of the grasses one may wish to sow. It is unnecessary to sow blue-grass seed, as on suitable lands it comes in naturally. The same may be said of many inferior grasses, that are practically weeds, so far as feeding value is concerned. Ungrazed patches show they are distasteful to stock. Pasturing mixed stock—not too many—of horses, sheep and cattle, would in such cases prove economical, as what was undesirable to one might be preferred by some of the others.

First, know your soil and the grasses you wish to grow, then test your knowledge in a small way, say at the rate of a dollar's worth to the acre each year. Keep at it and gradually add new varieties. Crowd out the weeds and encourage a vigorous growth by a regular top-dressing with good barn-yard manure. If this treatment does not ultimately enable you to maintain a cow to the acre, it will, at least, pay you a handsome profit on your investment.

J. HUGH MCKENNEY.

Cow-Peas for Iowa

AN IOWA reader has asked me about the Iron cow-pea. This is a medium late-maturing variety, a vigorous grower that makes a heavy vine which holds its leaf perfectly green until the pods are ripe. The peas are small, but the pods are long. Less seed per acre is required than in the case of larger-sized seeds. I should think the Iron pea was rather a late-maturing variety for Iowa. It requires the full growing season to mature seed here in southern West Virginia. The New Era pea matures about one month earlier and is a good, all-around variety.

A. J. LEGG.

The Overland The Simplest Car

The Overland outsells all other cars, largely because of its matchless simplicity.

The Overland—hardly more than two years old—has become the sensation of motordom.

Four factories, employing 4,000 men, turn out 140 Overlands daily to meet the overwhelming demand.

Texas takes 1,500, Kansas 1,000, Iowa 1,000, Nebraska 750—all for this season's delivery. So it is in every section where this remarkable car has been known for a year.

One reason is that the Overland is almost trouble-proof. The usual complex features have all been eliminated.

A child can master the car in ten minutes. A novice can run it and care for it.

One simply pushes pedals forward or backward to get on low speed, high speed or reverse. It is as simple as walking.

The car almost cares for itself. Many an owner has run from 7,000 to 10,000 miles without even cleaning a spark plug.

No expert is needed. And the cost of upkeep is the smallest of any capable car.

Then the Overland gives more for the money than any other car in existence. This is due to our enormous production and our automatic machinery.

For \$1,000 you can get a 25-horsepower Overland with a 102-inch wheel base. No other car of such size and power sells nearly so low.

For \$1,250 you can get a 40-horsepower Overland with a 112-inch wheel base. All prices include five lamps and magneto.

Know the Facts

More people are buying Overlands than any other car. There must be some very strong reasons, and those reasons will appeal to you.

We have two free books which will tell you the facts. Every motor car lover should read them. Cut out this coupon as a reminder to write for these books today.

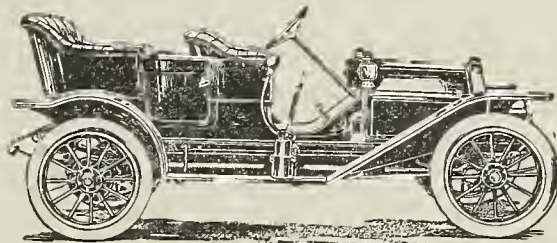

\$1,000 to \$1,500.—According to size, style and power.

The Willys-Overland Co.

Toledo, Ohio

Licensed Under Selden Patent
Please send me the two books free.

(E-12)

(48)

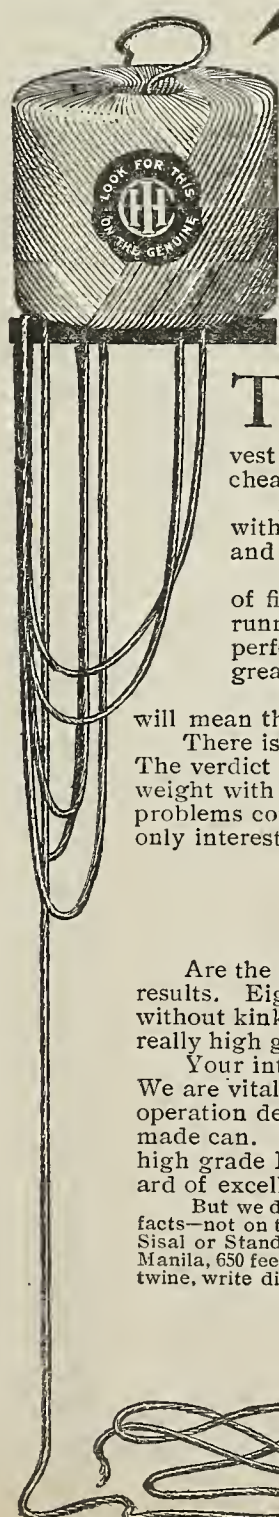

LET THE EXPERIENCE OF THE MAJORITY OF FARMERS BE YOUR GUIDE IN BUYING TWINE

THE time has come to order your binder twine for the 1910 harvest. Twine dealers are placing orders for their season's stock. The mills are running. Now is the time for you to decide the twine question. It is something that requires careful consideration. The success of your harvest will depend on the uninterrupted work of your binder, for no binder can work well if you use a cheap grade of binder twine.

It is our aim to have every farmer who uses IHC twine go through the 1910 harvest season without a break in the field. We have much more at stake than merely selling twine. Your interests and ours are the same.

We know that the raw materials from which IHC twines are spun have the quantity and quality of fibre that insure greater strength than is found in any other twine. They are evenly spun—smooth running—do not tangle in the twine box—work well in the knoter, insuring perfect binding and perfect tying. They insure your being able to work your binder through the entire harvest season with greatest speed and economy and are therefore practical profit insurance.

Those who buy cheap twine will certainly have trouble—delays due to tangles, knots and breaks will mean the loss of valuable time—and every delay at harvest time will cut down your profits.

There is a sure way to avoid this. Let the experience of the past be your guide in purchasing your twine. The verdict of the majority of the farmers of this country is a safe guide. Their decision should have more weight with you than the statement of any twine manufacturer. These farmers know. They have the same problems confronting them that you have. They have no axe to grind. They do not sell twine. They are only interested in results.

I H C Brand of Sisal—Standard Sisal Manila or Pure Manila

Are the twines used by the majority of the farmers of this country. They have been proved to give the best results. Eighty-five to 90 per cent of the farmers use Sisal. It is smooth running and works at steady tension without kinking or tangling in the twine box—insuring perfect binding and perfect tying. Its only equal is the really high grade Manila twines such as bear the IHC trade-mark.

Your interests and ours are identical on this twine proposition. We have more at stake than selling twine. We are vitally interested in the successful operation of hundreds of thousands of binders. On their successful operation depends our success—and we know they cannot operate successfully with poor twine. No binder made can. For this reason we have given the twine problem careful study. When we say "Stick to Sisal or high grade Manila bearing the IHC trade-mark"—we do so because we know them to be the highest standard of excellence in binder twine.

But we don't ask you to do as we say. We want you to be the judge. But your judgment to be right should be based on facts—not on the statement of any twine man. And the fact is—that the majority of the farmers of this country use IHC twine. Sisal or Standard (which is made from pure Sisal) comes 500 feet to the pound; high grade Manila, 600 feet to the pound; Pure Manila, 650 feet. See your local IHC dealer at once and let him know how much you will need. If you want more facts on binder twine, write direct to

International Harvester Company of America Chicago U S A

(Incorporated)

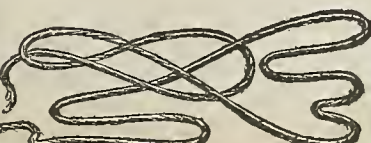

SUBSCRIPTION PRICE

One Year (24 numbers) 50 cents
Canadian Subscriptions . . 1 Year, 75 cents

Entered at the Post-Office at Springfield, Ohio, as Second-Class Mail Matter.

Subscriptions and all editorial letters should be sent to the offices at Springfield, Ohio, and letters for the Editor should be marked "Editor."

The date on the address label shows the time to which each subscriber has paid.

Subscribers receive this paper twice a month, which is twice as often as most other National farm journals are issued.

Silver, when sent through the mails, should be carefully wrapped in cloth or strong paper, so as not to wear a hole through the envelope.

When renewing your subscription, please say it is a renewal, and if possible send the label from a recent copy. If all our subscribers will do this a great deal of trouble will be avoided.



PUBLISHED BY

THE CROWELL PUBLISHING COMPANY

SPRINGFIELD, OHIO

Branch Offices: 11 East 24th Street, New York City

Tribune Building, Chicago, Ill.

Copyright, 1910, by The Crowell Publishing Company

ABOUT ADVERTISING

FARM AND FIRESIDE does not print advertisements generally known as "readers" in its editorial or news columns.

Mention FARM AND FIRESIDE when you write to our advertisers, and we guarantee you fair and square treatment.

Of course we do not undertake to adjust petty differences between subscribers and honest advertisers, but if any advertiser in this paper should defraud a subscriber, we stand ready to make good the loss incurred, provided we are notified within thirty days after the transaction.

FARM AND FIRESIDE is published on the 10th and 25th of each month. Copy for advertisements should be received twenty-five days in advance of publication date. \$2.00 per agate line for both editions; \$1.00 per agate line for the eastern or western edition singly. Eight words to the line, fourteen lines to the inch. Width of columns 2 1/2 inches, length of columns two hundred lines. 5% discount for cash with order. Three lines is smallest space accepted.

Letters regarding advertising should be sent to the New York address.

Laws Should Favor Fertility

AT THE Minnesota Conservation and Agricultural Development Congress, President Charles R. Van Hise, of the University of Wisconsin, repeated his demand that our laws be so framed as to prohibit the exportation of our phosphates. Doctor Van Hise is one of our greatest educators and is also a broad thinker along sociological lines. He first stated this demand in a way to attract attention in the White House conference of governors—which conference was the beginning of the real growth of the conservation movement.

The Van Hise phosphate doctrine is radical, but fundamentally appealing. If, as we are taught, the soil is permanently depleted by every crop taken off, the time will come when our farms will be no longer productive and we shall have to starve or reimport from some now undiscovered deposit the phosphates we are now sending to the depleted soils of Europe. The world will be phosphate-hungry and we shall have to buy back on a dear market the natural wealth we have allowed to be drained off at cheap rates. There is a phosphate combine, the control of which is in the hands of Schmidtman, a German capitalist, who is the Rockefeller of the phosphate business. Nearly all the phosphate mills of this country and Europe are controlled by him. Our supply is being rapidly decreased and this great combine of mills is under such control as to cut off all hope that the needs of our soils will receive the slightest consideration at its hands. Our own trusts are not expected patriotically to look out for posterity; how much less may such solicitude be looked for from a German corporation or one controlled by foreigners?

Doubtless the phosphate people would fly to the courts to have declared unconstitutional a law forbidding them to take away the fertility of our continent, but we believe that the law asked for by Doctor Van Hise would be supported, and that the matter should be studied and the law passed if needed. We are all interested, east, west, north and south.

The laws should favor fertility, and the railway companies should out of enlightened self-interest, sedulously seek to keep in their own territories all the elements of plant-food which can possibly be retained. Most of our wheat is shipped as wheat, instead of as flour. This involves to this country an enormous waste of the fertility in the loss of the bran and by-products. In the bran of every bushel of wheat is fertility which is worth in the market not less than twenty-five cents at present prices for fertilizers. All the wheat of Canada should be milled in the United States, in so far as it is possible to do so. This is impossible, though our milling capacity is ample, because of our tariff and our railway rates. The tariff laws have allowed the exporting miller to draw back nearly all the duty he paid on importing the wheat, but he was not allowed to sell the by-products duty free in the local markets. Our tariff laws literally forced the exportation of all this fertility. A ruling has recently been made allowing the bran and other by-products to be sold locally, on payment of a duty of twenty per cent of their actual value. This is better, but it is still wrong. The bran we need to buy for our cows should be let in free, to enrich the soils of the United States. Canada's soil exploitation would then benefit us instead of Europe.

* * *

Get a little of that good land out from under the stumps and stones on your farm this year.

Indiana has won the prize for the largest and best ear of corn at the National Corn Show several years in succession. The man who won the prize the last time says he worked up to this ear seven years. A bumper crop isn't made in a season.

Bob Seeds, of Birmingham, Pennsylvania, known as the farmer-lecturer, who has been lecturing all over this country on "How God Made the Soil Fertile," has now published his lecture in book form. Mr. Seeds—there is something agriculturalish about the name—lectures to sell his book, and then sells his books to create a desire to hear him lecture again.

Work for the International Sheep Fair

A NEW international stock show at Chicago is projected. This is to be, according to its prospectus, "exclusively for sheep," but will not be so exclusive as to exclude goats. The separation of these two animals is apparently to be deferred to a later, if not the last day. Collie and shepherd dogs will also be allowed "in," and there will be demonstrations of shearing, sorting, grading and other operations in wool and mohair, and contests in dipping, butchering and other shepherd's work.

If the show is decided upon, it is to be hoped that the economic side of the wool business will not be neglected. Most of our flock-masters have been taught to think that sheep cannot be successfully grown except under the protection of a tariff. This places the wool business in a most ticklish situation; for the wool tariff has fewer friends outside the sheepmen and the wool manufacturers than almost any other schedule. Even Mr. Taft is against it, though he stonily defends every other schedule in the Aldrich-Payne bill. Wool-growers should study the matter and see just how much they need this tariff. We know that sheep are grown profitably by English shepherds on land higher in price than ours, and in competition with the world. Why can't we do the same? Could we not do it if we knew our business? Do we know our business? These questions may well be discussed at such a fair as this in contemplation. For there are a lot more people who wear clothes than there are wool-growers, and we may find ourselves without a tariff at almost any time now.

* * *

Foresight is better than looking five times after it is too late.

Give the boys a big patch to farm, and they won't leave the old home.

There is too much grumbling and too little song in the world. If you sing, you won't throw clods at the horses.

Only the ignorant now take patent medicines. The ignorant do not read the first-class periodicals. Therefore, it no longer pays to advertise patent medicines in the first-class magazines.

If any of our readers have had experience in applying coarsely-crushed limestone to the soil, we should be glad to have their reports. The sort of limestone used is important to be stated.

A National Bureau of Health

THERE is something anomalous about the present condition of the United States Government health service. It is a branch of the military. Once the Weather Bureau was under army control, and the weather observers were officers of the army, with allowances for forage for their horses and other nonsense. When the service became really important, it was transferred to civil life and became a part of the machinery of the Department of Agriculture. Public health, one would think, would be better served by a Bureau of Public Health, as recommended by President Taft in his message. The great questions which confront us in the conservation of the public health are for the civil investigator, not the military surgeon. The latter have done great work, but in so far as it has been great work, it has been unmilitary. Doctor Stiles has immortalized himself by his brilliant and classic study of the hookworm, but it was not an army necessity at all which prompted the work. So many tasks confront us in the matter of public health that they transcend in importance the whole army and the whole navy. The bureau which deals with them should be a civil unit with capacity for independent growth. When we become a little better acquainted with the matter, we shall find it quite as necessary to take the control of our river improvements from the army engineers and give the work to civil engineers better qualified for it than army engineers can be. The army and navy may well be freed from these anomalous duties.

The Rural Schools on Trial

THOSE who think the present rural schools as good as we need must be prepared sooner or later to support their case with argument; for the rural schools are due to be reexamined as never before. The report of the Country Life Commission, advocating "a new kind of rural school," has only accelerated the existing movement for different schools.

Farming communities here and there are becoming convinced that their boys and girls are not having a square deal. It is not a square deal to the country boy to send him out into the world without industrial training, while the city boy receives industrial training. Such a deprivation will place the country boy for the first time in our history at a disadvantage, in both city and country.

The industrial education which every school, rural or urban, should seek to give is training for the life by which the pupils are surrounded. Rural schools should impart education in rural industry. If they fail to do this, they fail to give the country boys and girls a square deal.

The inherent lack in the country schools is that they seek to imitate the city schools. The city schools have been in the past rather poorly adapted to the real life of the city, but they have not been adapted at all to the life of the country. Our rural teachers are apt to come from the city schools, and they try, of course, to mold the rural schools to the forms of the only schools they know. The great mass of knowledge that lies about the country child's vocation is never touched. We give the farm boy or girl the schooling which the merchants, clerks and day-laborers of the city have prepared for their children.

There is a movement on foot in the cities to teach agriculture in the city schools. With this we have little sympathy. The city schools should be adapted to the making of good, skilful, city-dwellers. The country is the place where agriculture should be infused into every period of the school year. Let the city children stay in the city, where their home life is a valuable part of their education. Let the country children stay in the country, where they find the life out of school a half-training for the life of the farm. Swapping populations with the city involves enormous waste. The city people coming to the country will scarcely ever become good farmers, and the farmers going to town have to forget their old trade and learn new ones. This is wasteful in the extreme. With the one part of it, farmers have little to do; but the evil of the flocking of farm children to the city, we can do much to remedy by making every rural school, not only a place where reading, writing and arithmetic are taught, but where everything in the way of instruction shall be faced toward the cultivation of the land and the life of the farm. As a preparation for this, we need much work among teachers and school officers, and much thought by all of us. For, after all, the rural schools are what the farmer makes them, and always will be.

"On the Side"

THERE are many people who make money "on the side." Poultry is a side line for most farmers. It pays because the fowls pick up things that would otherwise go to waste. The dairy was almost universally a side line thirty years ago in the middle West, and is such on thousands of farms yet. There are many other side lines which farmers might take up with profit, if they only thought of them. Few are the farms which have not the facilities for something of the sort. FARM AND FIRESIDE hopes soon to print some letters giving actual experiences of those who have made successes "on the side." We shall be glad to have letters from those who can tell of actual experiences, either of themselves or others. Let us have names and dates and places, but not for publication unless desired. If we use your letter, we shall pay for it, of course. If not, you will have the satisfaction of having offered the world of farmers a bit of helpful information, anyhow. Please let us have your experiences and observations relating to "Agricultural Side Lines."

The Inside of the Great Investigation

A Complete and Accurate Statement of the Evidence Brought Out in the Pinchot-Ballinger Inquiry

By Judson C. Welliver, Editor of the Farmers' Lobby

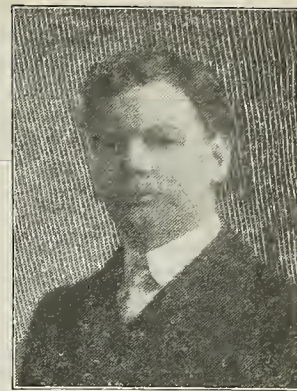

JUDSON C. WELLIVER

THE congressional committee investigating the Ballinger-Pinchot feud has been taking testimony for several weeks and, at this writing, is not in sight of the end of its labors. Something like two thousand printed pages of testimony have been taken which probably very few people, aside from the lawyers and the committee, will ever read. Out of the maze of testimony it is perfectly apparent now that adroit special pleaders are going to be able to find wherewithal to sustain almost any theory or set of conclusions they want to promulgate.

In the beginning of an effort to state in simple form the substance of what has developed thus far a word about the joint committee of twelve which is conducting the investigation. The committee's procedure, its attitude toward witnesses, its treatment of evidence, have all justified the impression that it would attempt to vindicate Ballinger. Senator Nelson, of Minnesota, chairman of the committee, has been extremely antagonistic to the Pinchot case and to the Pinchot witnesses. Senator Root, of New York, though somewhat more diplomatic about it, has been quite as biased in favor of Ballinger. Representatives Olmsted, of Pennsylvania, and Denby, of Michigan, must be similarly classified. Senator Flint, of California, has been more nearly fair, but on the whole, like Senator Sutherland, of Utah, is disposed to be mildly antagonistic to the Pinchot case.

Indifference on the Minority Side

SENATORS Purcell, of North Dakota, and Fletcher, of Florida, Democrats, while taking no very active part, have indicated a disposition to be fair. But they are both new senators, utterly inexperienced in this sort of work and entirely incapable of coping effectively with the legal knowledge of Root or the intimate knowledge which Nelson possesses of everything concerning the public domain. If the Democrats of the Senate had been sincerely concerned about making the investigation a real one and getting more out of it than a mere political play, they would have insisted that two experienced and thoroughly-trying men, equipped to cope with such veterans as Nelson and Root, should represent the minority on the committee.

Of the other members of the committee, Mr. McCall, of Massachusetts, has taken very little part in bringing out testimony, but has been distinctly fair. Mr. Madison, of Kansas, is the representative of the Republican insurgents of the House. He has indicated a decidedly strong partizanship of Pinchot and antagonism for Ballinger. But I am bound to say that anybody watching the case day by day must agree that he is the one man on the committee who has indicated a desire to make the inquiry bring forth illumination of the things the people of the United States want to know about. Finally there are two Democratic representatives on the committee, Mr. James, of Kentucky, and Mr. Graham, of Illinois, both strong critics of Ballinger throughout.

Half a Billion Tons of the People's Coal

NOW as to what has been actually brought out. Mr. Pinchot had charged that the public interest in the public domain was unsafe under the guardianship of Mr. Ballinger as Secretary of the Interior. Lewis R. Glavis had charged that the department under Ballinger had been friendly to the so-called "Cunningham group" of claimants to very valuable coal-lands in Alaska. The Glavis and Pinchot people long ago insisted that the Morgan-Guggenheim Alaska syndicate were certain to get these coal-lands if once they were patented to the Cunningham claimants. Cunningham and his associates denied this, and the Ballinger people branded it as mere imagining.

The thirty-three Cunningham claimants have filed on about five thousand acres of coal-lands in the midst of the Katalla coal-field in southern Alaska. The lands are so located that they dominate the entire field. Representatives of the Guggenheim-Morgan syndicate recently testified, before the Senate Committee on Territories, that whoever controlled the Cunningham claims would control the entire Katalla field. They said that in that field were at least 500,000,000 tons of available coal, in the mining of which there would be a profit to whoever controlled the field

of from \$200,000,000 to \$250,000,000. There, in brief, is what the Cunningham claims stand for.

Was Pinchot dreaming and was Glavis crazy when they charged that Cunningham meant Guggenheim and that if these lands were once patented to the Cunningham claimants they would at once become the property of the Guggenheim syndicate? Stephen Birch, managing director of the Guggenheim-Morgan syndicate, answered that question when he frankly told the Territories Committee that the syndicate had bought an option on the Cunningham claims for \$250,000 and would take them over just as soon as they were patented! Cunningham himself had made an affidavit that the Guggenheim-Morgan syndicate had no interest whatever in the lands. Plainly, either Cunningham or Birch had lied. Plainly, likewise, Birch didn't lie, for the statement he made was decidedly adverse to the interest of his syndicate.

Not only did Cunningham tell a falsehood in this affidavit, but that false affidavit was turned over to Ballinger to be presented to Secretary of the Interior Garfield as the conclusive argument why the Cunningham claims should be put to patent. Ballinger accepted this service during 1908, in the interim between his retirement as Commissioner of the General Land Office and his return to official life as Secretary of the Interior.

To say the Cunningham affidavit was false does not prove that Mr. Ballinger knew it was false. But leaving that aside, Mr. Ballinger in accepting this very questionable legal employment, was specifically violating a law which forbids an official, after retiring from service in one of the government departments, from prosecuting in that department any claim against the government for a long period after his retirement. Mr. Ballinger, then, may have been entirely innocent in the matter of lugging the perjured affidavit all the way from Seattle to Ohio in order to present it in person to Secretary Garfield. It is hard to believe so good a lawyer as he is reputed to be could have been ignorant of the fact that in any case he was violating both the law and common decency in performing such service under the circumstances.

Cunningham Gets the Benefit of Every Doubt

WE WILL NOW go back to the time when Mr. Ballinger was Commissioner of the General Land Office and Cunningham was trying hard to get these precious claims patented. Louis R. Glavis, special agent, had been investigating these claims. An agreement among the individual claimants to combine their holdings after securing their patents would have made all the claims illegal and fraudulent. Glavis told Ballinger he believed there was such an agreement, but admitted he could not yet prove it. That was in December, 1907. Notwithstanding this adverse report, Ballinger, within a few days thereafter, ordered the Cunningham claims patented. Glavis learned of this order and telegraphed a heated protest to Washington. By the time it was received the patents were actually drawn up ready for execution and delivery; a fact which alone indicates that the Land Office was working with remarkable and unaccustomed celerity in the matter of getting this particular set of claims to patent. Such speed was almost without precedent.

The determined protest of Glavis prevented the patents being issued after they had been drawn. They are still being held up.

Now as to Mr. Ballinger's justification for ordering that these patents be issued, in the face of Glavis' adverse report on them. The Ballinger people claimed that another special agent, D. K. Love, had reported in favor of patenting the claims. Ballinger claimed he was simply acting upon the Love report and ignoring the Glavis report. But when the Love report was put into the testimony, it was found he had only partially investigated and that his report was to all intents and purposes adverse. By no possible construction could it be made reasonable excuse for issuing the patents in the face of the opposition of Glavis, with his much more complete information.

But assuming that the Love report, on its face, was favorable to the claims. In accepting the advice of Love in preference to that of Glavis, did Mr. Ballinger display the wise discretion of a good executive officer?

The answer to that has been clearly brought out in the testimony. Glavis himself, after the patents had been held up, proved his case by getting from Cunningham the documentary evidence that there was a combination and unity of interests among the claimants which made them fraudulent!

At the time of these transactions Ballinger was Commissioner of the Land Office. After he became secretary, he nominally turned over all matters relating to these claims to Assistant Secretary Pierce. But, in fact, it is shown that without special reference to this set of claims he issued various general orders designed to hasten all pending matters to conclusion. Haste was just what the Cunningham claimants wanted.

One of the last things Mr. Ballinger did before retiring as Land Office Commissioner was to appear before the House Public Lands Committee, urging a bill that would have enabled the Cunninghams to get their patents, despite that the claimants had entered into a combination. Before it passed, this bill was amended in such fashion as to leave some uncertainty whether it cured the defect incident to the combination. That question was submitted to Assistant Secretary Pierce, who made a ruling that the new law did meet this point. Under this ruling, if it was correct, the last excuse for refusing to patent the claims had been removed.

Ballinger Tries to Keep the Cat in the Bag

AND here comes a curious coincidence. Glavis happened to be in Washington when that ruling was made. He protested to Secretary Ballinger that Pierce was wrong in his construction of the law and urged that the question be sent to the attorney-general for an opinion. Secretary Ballinger agreed; Glavis, assisted by some other people in the Interior Department, prepared a letter to the attorney-general, and left it with Mr. Ballinger for signature. Mr. Ballinger gave Glavis to understand that he would forward it to the attorney-general; but instead of doing so he sent this letter also to Assistant Secretary Pierce, thus, of course, destroying all chance of getting the Pierce ruling reversed.

Glavis, sorely disgusted, told his troubles to Henry M. Hoyt, then one of the government's law officers, and asked his advice. Hoyt looked up the matter, became convinced Glavis was wrong and went to the attorney-general and the President about the matter. The result was that through this channel, which Mr. Ballinger had seemingly been so anxious to keep out of, there was secured from the attorney-general an opinion which reversed the Pierce ruling, and held that the claims were fraudulent and could not be patented, despite the new law. Mr. Hoyt, while on the witness-stand before the investigating committee, recounted these transactions in most convincing fashion and his testimony probably did as much to break down any remaining confidence in Secretary Ballinger's sincere purpose to protect the government as any development since the controversy began.

Whitewash, Tar and a Ray of Light

THE foregoing, I believe, covers pretty well the substance of what has been developed by the investigation thus far. Those who have studied it most carefully have been most impressed that it makes an exceedingly bad showing for Secretary Ballinger.

As to the conclusions of the committee, it seems probable that three reports will be submitted. I should venture the guess that Senators Nelson, Root, Flint and Sutherland, and Representatives McCall, Olmstead and Denby, constituting just a majority of the committee, will plaster Secretary Ballinger with an iridescent coat of whitewash. I should guess further that Senators Purcell and Fletcher, and Representatives James and Graham, all Democrats, will make a very strong anti-Ballinger finding. And, finally, I would venture that Mr. Madison will make the one report which will commend itself to unbiased and temperate people as a fair statement of the case, devoid on the one side of partizan rancor and on the other side making no attempt to whitewash Ballinger or to conceal a disaffection with his course, amounting to conviction that he is an unfit person to be continued at the head of the Interior Department.



Money-Making for Women

Raising Squabs and Pigeons

By Sarah T. Lyon

With Photographs by Author

WHEN one stops to consider, it is surprising what a variety of things present themselves in which women can succeed.

The fields that are open to her are so many and varied that there is considerable latitude allowed her in the matter of choice.

Of all the phases of rural pursuit, none proved more interesting to me than that of raising pigeon squabs, and one does not have to be an expert, either, to succeed from the very start, as I can vouch from actual experience.

To read the catalogues of breeders of homing pigeons, who sell birds to the beginner, some of the most misleading and extravagant claims are made as to the money-making possibilities in this field of effort.

One catalogue reads that "Every pair of homing pigeons will rear eleven pairs of squabs a year, or a pair every month in the year, except the month of February."

Such statements are gross misrepresentations to lure the inexperienced, for experience has proved again and again that five pairs of squabs from a pair of good breeders is a fair average, and even at this the profits are considerable.

To make a start does not require much capital, as a building eight feet wide, eight feet high and twelve feet long, with wired flight yard, will afford ample and comfortable quarters for a hundred or more breeders.

While a number of breeders advocate a cross between the homer and the Runt, claiming that the squabs will be much larger because of the Runt blood in the parents, yet experience has proved again and again that the pure homing pigeon is the best. They are hardier, better feeders of their young and not so prone to disease as the cross breeds. It is wise to buy from reliable and experienced breeders.

If you make your start with a few pairs of mature homing pigeons, under no circumstances give them their liberty, for, true to the instinct that gives them their names, they will fly away and try to return to their former quarters.

As a matter of fact, none of the birds really need a greater range of flight than that afforded them in their houses together with the attached flight-yards, which should be wired in on all sides.

Some expense can be saved by utilizing existing buildings on the place and attaching wired-in flight-yards to the same. Pigeons readily make themselves at home and are contented with what they get, provided they are properly protected from the elements and supplied with food and water.

It is a shame to raise pigeons in old boxes nailed to the sides of a barn, as the birds suffer during severe weather, and when having such freedom, often do much damage to the fields and gardens and are prey for hawks, owls and pot hunters. Such quarters are, to say the least, untidy, and a variety of reasons urge us to confine them in proper quarters where they are constantly under our control.

Have one or more panes of glass in the south side of the structure used, with holes cut through the front of the building near the top, with alighting-boards on the outside, and have the openings open into the flight-yard, which should be as wide as the building, about eight feet high and about twenty feet long.

The flight-yard should be boarded up on the sides and end to a distance of two feet. They should be

covered with one-inch-mesh wire net to keep out sparrows and other enemies which molest the pigeons.

Have at least three alighting-poles in each yard, resting on the wire net about five feet from the ground, as the birds greatly enjoy a resting-place some distance from the ground.

As pigeons breed in pairs, it will be necessary to provide in each house a home for each family, and for this purpose boxes two feet long by one foot wide with a partition in each box and an alighting-board are the very best.

When nailed to the walls of the house, each box is open in front, with the exception of a strip of wood that should be nailed across the front to prevent the young squabs falling out of the box.

It is not an uncommon thing for a pair of birds to have young squabs in one side of the box and eggs in the other.

The interior of the house and the nesting-boxes should be white-washed and kept spotlessly clean. Cleanliness is more necessary in a pigeon-house than in a hen-house. It is well to store all pigeon-manure in barrels, as florists are generally glad to pay a fair price for it.

Pigeons require plenty of water and, therefore, care should be taken to see that drinking-fountains are near them and that the water is always clean. Strange as it may seem, pigeons are most particular about the water they drink. They will not take defiled food or drink unless they are actually starved into it.

The feed for the pigeons should be near them in hoppers, built on the gravity plan, and under no circumstances should the birds be fed in open boxes, as they are certain to scatter the contents all over the floor.

The floor of their house should be thoroughly whitewashed and a liberal allowance of gritty sand sprinkled over the floor, for grit is absolutely essential to the good health of the birds.

A great many people feed their pigeons quantities of hemp-seed and then wonder why they die.

A little now and then is all right, but too much is fatal.

For feed, give them two parts whole corn, two parts wheat and one part buck wheat, with an occasional dash of whole oats. Under no circumstances feed them cracked corn.

Cracked oyster-shells should always be near in a pan and, as pigeons are fond of salt, a piece of dried salt codfish should be nailed where they can peck at it.

Always keep the feed-boxes filled up so that the pigeons can have access to food at all times, when they have young ones to feed.

Both the male and female set on the eggs, the male during the day and the hen at night.

The eggs hatch in sixteen days and it is astonishing how fast they grow. The parent birds take good care of their young and assume all responsibility of feeding and rais-

ing them until they are ready for the market. Pigeons are faithful creatures and remain in pairs for years, and if an accident happens to one of them, will frequently refuse to mate a second time the same season.

Avoid all violent action among the birds, and if it becomes necessary to catch a bird nothing is better for the purpose than an ordinary crab net.

Filth and lice can be overcome in a large measure by giving the birds proper attention and using one-inch-mesh wire netting in the flight-yards to keep the sparrows out.

By frequent baths, the old birds kill most of the lice, and a little insect-powder scattered in the nest-boxes



The interior of a sanitary pigeon-house, showing alighting-boards

will keep the babies comfortable and clean. Pigeons bathe daily.

Pigeons are susceptible to disease and the best cure is prevention.

"Going light" is a disease and is a tubercular affection of the bowels, and such birds as are affected should be removed from the flock.

Squabs are sometimes afflicted with a cankerous mouth, and burnt alum should be applied to the sores.

Never under any conditions buy white wheat—always buy red, for the former very often causes diarrhea.

To fatten squabs for the market, once a week give them a meal of stale bread which has been steeped in skim-milk and squeezed almost dry again.

The squabs are ready for market when they are ready to fly from the nest and are easily caught.

The matter of color is one of choice and some breeders prefer the white homers to the slate colored, as the dressed squab presents a more attractive appearance.

Squab-raising may be repellant to most women when it comes to the killing and dressing for market, but this objection can be overcome as in the matter of raising poultry for market.

A man can be hired to do the killing and picking at stated times or else the birds can be sold alive.

If any woman shrinks from this phase of the business, she need never kill the squabs, but can rear them to maturity and sell them as breeders to those starting in the business. There is always a ready market for first class breeders, the prices ranging from one dollar to two dollars a pair, while in the case of good specimens often as much as four dollars a pair can be realized.

If you start with a few pairs of birds, the best way to increase the number is to sell the squabs, and use the money to buy mature birds, for it takes pigeons six months to reach maturity, and it is necessary to have two extra houses in which to keep the growing birds, as they should not be allowed to remain in the regular brood-pen. If, however, you have specially-mated birds and desire to raise their progeny, you must watch the nests, and as soon as the young ones get out on the floor (the old ones generally push them out when the eggs in the second nest hatch) they can fend for themselves, and should be removed to a nursery-house, where all feed must be cracked to the size of rice for several weeks. When one desires to build up size and good points, it is necessary to have two nursery-houses, and so be in a position to select the best birds from different parentage to mate.



A picture of two baby squabs which are just one week old

With the Editor

A good deal is said from time to time about work for work's sake. There is a lovely theory sometimes preached that we ought to just simply love making bricks, running engines, operating machines, following the plow and washing dishes.

All this is nonsense. Fortunately much of the necessary work of the world is pleasant. Fortunately the human mind is so constituted that it finds pleasure in the efficient performance of work. But, after all, much of the day's work all along the line is and must be hard and unpleasant. We work because we have to. We have to, because we must live. And by the "we" who must live is meant the wife and the children.

And, really, most of it simmers down to a matter of the children, doesn't it? The children keep the lamp burning over the sewing-machine until dawn the days before school opens. The children cause the thrill of terror at the thought of the unpaid mortgage rapidly maturing. The children give the joy to the Sunday afternoon walk about the fields as the corn jumps three inches overnight after a shower, and the yellowing wheat pulsates toward harvest in waves of light and shadow. These things are in themselves as beautiful as a poet's dream; but back of much of their beauty is the feeling that corn and wheat and cattle and sheep mean well-fed, well-clothed, well-raised and happy children.

Then why not live more completely for the children? Why not take them more definitely into our plans? Why not think over the question as to whether or not we are doing the square thing by them?

I claim that, while we spend millions for schools, we are wasting most of the money. I claim that the country child is not getting his share of progress. I claim that the rush of our young people to the cities is natural and quite to be expected in view of the fact that we are educating them in schools that impress them with the feeling that the happy life is to be found in the city, and the unsuccessful, frustrated, narrow, humdrum life is to be lived in the country. The first proposition is false. And whatever truth is to be found in the second is largely the fault of the fact that our training in the rural schools is not adapted to making the most of country life.

The American rural schools made the pace for the world a century ago—yes, fifty years ago. They were not what schools should be now in country districts, but they were, on the whole, perhaps the best schools for the making of men and women in the world.

Are they as good now? Some people would say "No;" but I am not one of these. I think that the school to which your children go is probably better than the one their grandparents attended. But to compare the school of fifty years ago with a school of to-day is as unfair as to put the covered wagon that grandpa and grandma moved in beside the railway train that carries the "home-seeker" to-day.

And that's the point I want you folks to think of. Aren't your children in the country school getting the school of the covered-wagon period when they are entitled in justice and right to the school of the railway period?

I was at St. Paul recently attending the Conservation and Agricultural Development Congress. I saw hundreds of Minnesota farmers sit in tense interest listening to conservation speeches and to none of them did they give heartier applause than to those appealing for better boy-harvests and higher-quality girl-crops.

"I was once at a place in Virginia," said one speaker—Professor Dunton, I think it was, "where hundreds of boys and girls were being taught the work of their lives along with the things in books. They were employed every day in the actual learning of better ways to do farming, housekeeping and mechanical labor. Their school was not so much a preparation for life—it was life itself.

I said to myself, 'I wish my children could attend such a school! This is real education!' And only one thing prevented this—my children are white. This best of schools is for negroes only.

"And at a place in Pennsylvania I saw a great number of young people being trained for occupations, as well as for scholarship. The girls sewed and cooked. The boys plowed and sowed and pruned. And along with it all went lessons on the why as well as the how, so that they made faster progress in their books than they would have done if they had had nothing but books. But I was saddened to think that my children could not go to this school—because they are not Indians. For it is an Indian school.

"And up in Wisconsin I saw a school where boys had such lessons that their brains and hands worked at the same time. Most of these boys came to this school hating the thought of it. But they loved it so after a while that when the time came for their leaving, they sometimes refused to go. But my boy could not attend this school, because he had never committed a crime. The negroes, the Indians, the criminals are given good educational opportunities, while the white boys and girls who are good are still fed on the husks dried for the use of a century ago!"

Is there anything in what he said? It seems to me that there is. It seemed to the Country Life Commission that there is something in it, or they would not have recommended "a new kind of country school." It must have seemed to the farmers who heard the speech that

there was something in it, or they would not have applauded so long and so heartily. It must seem to Jessie Field, of Page County, Iowa, that there is something, or she would not have made her fine battle for a different kind of country school there. It must seem to millions of people over the land that there is something in what the speaker said, or Miss Field's splendid work would not have given her national fame.

I hope all of our readers will read what Miss Field is writing for us, and ponder over it. Miss Field is not saying the last word on this matter, but she is saying a noble and inspiring word. She is telling from her own experience how the little one-room school-house may be made the temple of a better school system, without its costing a cent additional. Not that the newer, greater things of agriculture in the rural schools can be had without costing anything. Good things have to be paid for. But the greatest part of the price of better schools can be paid in the coin of unselfish labor and community planning.

On the train the other day I met a man who told me of the work that the University of Cincinnati is doing to make productive labor go hand in hand with schooling. Certain manufacturers take students of engineering into their machine shops where they work for a week and then go a week to the engineering school. By the time they have passed through the university they are master machinists, ready to take charge of almost any sort of work. And all the time they are keeping up with their classes, so that at the end of four years they are not only skilled mechanics, but high-class theoretical engineers.

While such improvements are being introduced into city and institutional schools, is it fair for farm children to be taught nothing of the new things in farming?

The great governing principles of farming are as easily taught to young children as are the effects of stimulants and narcotics or physiology or United States History or any of the common branches. And the things studied could be worked out in the great laboratory of the farm day by day and season by season. All that is needed is interest. Not half so much money as keen interest. Cannot the readers of FARM AND FIRESIDE all over the nation be the movers in awakening such interest?

Robert L. Dyer

FARM AND FIRESIDE'S OFFER TO READERS

To introduce Farm and Fireside to a few of your neighbors who are not now subscribers, the editors make you this unparalleled offer:

Get two people each to give you 25 cents for an 8-month trial subscription to Farm and Fireside. Send us the 50 cents, and in return for the favor we will send you Farm and Fireside for 8 months without cost after your present subscription expires. (If you are not now a subscriber, your own subscription will be entered for 8 months without cost.) In addition, the editors will send you a Beautiful Gift, with their compliments.

FARM AND FIRESIDE Springfield, Ohio

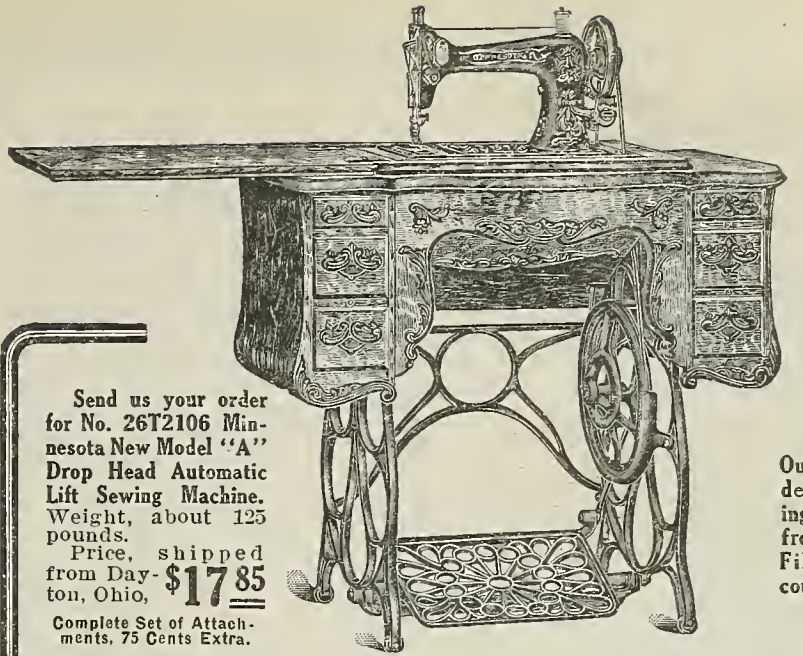

Send us your order for No. 26T2106 Minnesota New Model "A" Drop Head Automatic Lift Sewing Machine. Weight, about 125 pounds. Price, shipped from Day—\$17.85 ton, Ohio, Complete Set of Attachments, 75 Cents Extra.

Our Catalog describes Sewing Machines from \$8.45 up. Fill out the coupon.

This Six-Drawer Automatic Lift Drop Head Style Sewing Machine

Has the following special features which have made this model famous:

- Ball Bearing
- Short Needles
- Extra Long Shuttle
- Disc Tension
- Automatic Bobbin Winder
- Special Needle Plate
- Independent Positive Cam Take-Up
- Automatic Tension Release
- Extra Large and Strong Feed
- Round and Hardened Needle Bar

OUR SPECIAL SEWING MACHINE CATALOG is a book you must have if you contemplate buying a sewing machine. It shows all our various models, many of them in colors just as they appear; illustrates the various parts, tells you all about everything you want to know, explains fully our twenty-year guarantee, our three months' trial contract, and describes the uses of all the special attachments. Fill out this coupon carefully with your name and address. The very day we receive it we will send you a free copy of our special Sewing Machine Catalog.

Sears, Roebuck and Co. Chicago, Ill.

S. M.—Farm and Fireside

Name _____

Postoffice _____

R. F. D. No. _____ State _____

P. O. Box No. _____ Street and No. _____

Sears, Roebuck and Co., Chicago, Illinois

Don't You Need a New Watch?

The present day demands for reliability and "on time" precision make an accurate timepiece not only necessary, but imperative. No one knows this better than the man who lives on the farm and whose requirements for watch-accuracy are just as many and just as exacting as those of the man in town.

In selecting a watch, remember that the

Elgin

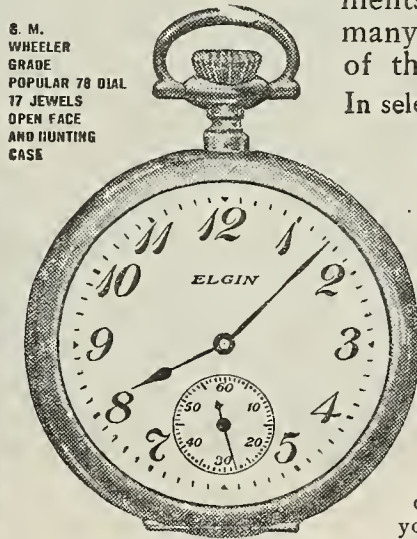

S. M. WHEELER GRADE POPULAR 75 DIAL 17 JEWELS OPEN FACE AND HUNTING CASE

is recognized everywhere as the watch of unflinching accuracy. One Elgin movement in particular that is very popular, both as to price and dependability, is the G. M. WHEELER grade. Perfectly adjusted for temperature and three positions. Made in the standard sizes. Among the various other Elgin models there may be some particular one that most fully meets the requirements of your occupation. If you will write us indicating what you do and your special needs for a watch of unflinching precision, we will write you fully, explaining the very Elgin watch made for you, and will direct you to the nearest jeweler handling it. There is absolutely no charge for this service. Write us to-day.

ELGIN NATIONAL WATCH CO., ELGIN, ILLINOIS.

Here Is Something New From Kalamazoo

Prove for yourself in your own home, that the Kalamazoo is the most perfect—most economical—most satisfactory range for you to use—Your money back if it's not. Send for Catalog No. 183 with special terms and compare Kalamazoo prices with others

Cash Or Time Payments

We want every housewife to know the comfort and convenience of a Kalamazoo in her home. You can buy on easy time payments or pay cash if you like. Either way—you save \$10 to \$20 on any stove in the catalog. We make it easy for responsible people to own the best stove or range in the world.

We Pay the Freight

Kalamazoo Stove Co. Kalamazoo, Mich.

A Kalamazoo Direct to You



Grandmother-Hunting

By Beulah Hughes

Illustrated by Ruth M. Hallock



PAUL was being undressed for bed. Of all the day this hour was most filled with joy for him, because he could have his father all to himself and there were so many things to talk about.

"Well! Faver, did you find her to-day?"

"No, son; not yet," answered the man, half sadly.

"Gran'movers is purty hard to find, ain't vey?" Then, holding his pink toes nearer the merry blaze of the open fire, he added very earnestly, "You don't fink Mis' McMurfy would do, do you?"

Mrs. McMurfy was the kind-hearted housekeeper of the family hotel in which they were living.

"Well, hardly, son! Here, let's fasten your nightie." "Has her name just got to be like ours?" insisted the child; for, otherwise, he thought the housekeeper would do very well.

"Oh, her name's bound to be Stanforth, old man," he answered. Then to escape further questioning the father switched off the lights and with Paul over his shoulder started on a prancing journey around the room, and the delighted child cried in ecstasy: "Who wants to buy a pig?"

But the man's gaiety was all assumed. Life, and especially the future of his little son, had become a problem to Philip Stanforth since the death of his wife. He had laid his whole heart at the feet of the little woman who had come so near paying with her own for the life of their boy. Only by the aid of the best medical skill had the five following years been possible. And such happy years had they been; marred only by one great disappointment—the failure to undo a mistake of Stanforth's boyhood.

Little Paul had been rarely out of his mother's presence and the first lonely nights of the heartbroken husband were filled with a sense of his own inability to comfort the child.

The wife had been an orphan when he married her, but Mr. Stanforth felt that in spite of his long unrewarded search there was somewhere in the world a woman who would love the baby son with an unselfish devotion, and that woman was the man's own mother.

Impetuous by nature, Stanforth had almost from infancy been at constant friction with his harsh, domineering father, for whom he bore no love. All the affection of his young heart was given to his patient long-suffering mother; but even her love could not compensate for his father's tyranny. And so one night, after a particularly severe and unjust punishment, he had left home.

It was many years before he realized the enormity of the burden he had laid upon his mother, and when from an industrial school where he was learning the printer's trade he wrote to her, his letters were returned. With the last one came a note from the postmaster of the small town saying that several years before the father had gotten into trouble and, taking his wife, had sneaked out of town, leaving no address.

Then had commenced the search in which, after their marriage, he had been joined by his wife. Stanforth had never lost heart, for he felt sure that success would eventually reward his efforts.

But now, remembering his own unhappy childhood, the immediate welfare of his motherless boy became his chief thought. He had no intention of telling Paul about the little woman for whom he was seeking; but one night the child had cried so hard for his mother that, in a desperate effort to comfort him, the father had suggested trying to find a grandmother. Paul had several small friends who possessed grandmothers, and having some idea of their many virtues where boys with hungry little minds and stomachs were concerned, he ceased his wailing to ply his astonished parent with questions. The father, overjoyed at finding something to divert his boy, entered readily into a lengthy discussion: and what had at first been the hint of a mere possibility became a definite promise, the binding character of which Mr. Stanforth was aware ere many days had passed.

The child lost the poignancy of his grief in the enchanting occupation of grandmother-hunting. Almost every night at bed-time he had, as in the case of Mrs. McMurfy, some new suggestion to offer and often so besieged his father with inquiries that to protect himself the puzzled man would start a romp as he had done this evening.

Soon wearied by the animated game, the child breathlessly demanded: "Now let's sing!"

Knowing the part he was expected to play, Stanforth feigned astonishment.

"Sing! Whew! Whoever heard of such a thing? Why, what could we sing?"

"Old Mother Hubbard," laughed the boy, scrambling to his father's arms in the easy chair. "One—two—three—go!" and they launched into a nightly program of the Mother Goose rhymes with which Paul's mother had put him to sleep. While singing about the sins of Tom, the Piper's Son, the wee man's voice trailed into a sleepy murmur and Stanforth, drawing his boy closer, began crooning a little lullaby he had found in a paper some weeks before. The words of the poem had found an echo in the heart of the lonely man, and he had set them to a little air his wife had sung to their child.

You cried in your sleep for your mama dear,

Baby, Baby!

I would you could call her back to us here,

Baby, Baby!

All the lambs are asleep on the sod,
And my own lambkin's beginning to nod,
And back of the starlight your mama's with God,
Baby, Baby, Baby!

Sleep has come to the birds with the dew,

Baby, Baby!

Her eyes were as blue as the eyes of you,

Baby, Baby!

Dreams for your slumbers come up from the deep,
I'll hold as she held you till morning lights peep,
And mama in heaven will watch while we sleep,
Baby, Baby, Baby!

The fire had died down to a red glow. In its reflection the man sat with his sleeping boy in his arms, and the silence was broken only by the plaintive tone of a violin in the suite below.

Suddenly there came an energetic knock at the door. Rousing himself from his thoughts and reaching for the light-key, Stanforth said: "Come in— Oh, walk right in, Mrs. McMurfy. I wish to thank you for your kindness to Paul since his nurse left."

"Ah, sure and ye ain't got anything to thank me fer. Sure it was a pleasure to have him follerin' 'round after me. Here, sir, is a letter I picked up in the hall on me way. Now bless the baby, ain't he that sweet in his nightgown you could just eat him? An' what do ye think he said to me to-day, the darlin'?"



"'Has her name got to be just like ours?' insisted the child"

Sure, says he, an' how'd you like to be a grandmother? But here I am 'most fergittin' what I come fer. I hope, sir, as how you won't think I was gossipin' when I told Mrs. Bardley, the music-teacher as has the suite just under ye, what a time ye were a-havin' keepin' a good nurse fer the baby here. An' says she to me, 'Why don't he take the child 'round the corner to the private nursery and kindragarden?' That's where she leaves her own baby when she goes to give lessons on the fiddle an' says as how the lady what keeps it is mighty kind to the children."

"What time does it open?"

"You mean in the mornin', sir? Well, usually about eight, sir, but the lady told Mrs. Bardley when she stopped this evening for Clara that she had some business to look after to-morrow and won't be there till after nine. But, sir, I'm to fetch Clara there in the mornin' and could just as well take the two of 'em. Then ye can stop on yer way home for the boy, an' seein' ye like the place, it might be yer wish ter send him there every mornin'. Ah, there's me bell; I must be goin'. Shall ye be wantin' the boy to go in the mornin', sir?"

"Yes, thank you, Mrs. McMurfy. Good-night."

And as the door closed Stanforth rose to put Paul in his bed, saying softly to himself, "It won't hurt to try the plan."

Coming back into the sitting-room, Stanforth picked up the letter Mrs. McMurfy had left on the table. Finding it to be from a friend who was legally aiding the search for his mother, he hastily tore it open to read these words:

DEAR LEISTER:—

Have found a clue which seems to be working splendidly. Have written the lady to bring papers, etc., and meet me to-morrow morning. She is a widow and has been living for several years in the far West and has been here only a short time, but, remembering past failures, don't bank too much on it.

Will drop by News office about four-thirty and let you know the results. Can't get there a minute sooner; but that will give you time to call on the lady if you think it worth while.

So long, old man. We'll find a grandmother for that boy yet.

Sincerely, etc.,
HOLDEN.

After a restless night, Stanforth wakened his son the following morning for a good-by kiss. Paul grew enthusiastic over going to a place where there were other small boys; but not even this new attraction could dim in any way what had come to be his dearest wish—and just as his father was leaving the bedroom he was called back and a troubled little voice inquired: "You're sure Mrs. McMurfy wouldn't do, faver?"

"Oh, quite sure, son!"

Then as the outer door was closing, "Faver, come back just one more minute."

"What now, you rascal?" laughed Stanforth.

"W'y, maybe she wouldn't mind changing her name."

"See here, young man, don't you go to proposing to the housekeeper in any such fashion! No, dear, we will look a bit farther. Now good-by, be a good little man and to-night I may have something to tell you."

Proudly escorting her two charges, Mrs. McMurfy was received at the door of the kindergarten by a prim little maid who registered Paul's name and took the children into the sunny play-room where a sweet-faced motherly-looking woman was playing with a crowd of boys and girls.

She came over and spoke to Clara, and turning to Paul she exclaimed, "And here is a new little pupil."

The boy was charmed by her smile, and though he had no idea in the world what a pupil might be, he was glad to be one. He hoped she wasn't mistaken.

"And what is your name, dear?"

"Paul."

Without stopping to question him further the lady thrust a flag into his hand and said, "All right, Paul, you may carry this. We are going to march."

His boyish soul delighted in marching, and forgetting the strangeness of the place, he fell in line and started sturdily around the room, endeavoring to hold the flag straight and at the same time keep from stepping on the heels of the tiny girl in front.

After the marching there were other games to set the little people laughing, and at lunch-time came a real party at the tiny tables.

The children sat in small green chairs and had bread and butter and some jam and mugs of nice sweet milk and, best of all, little crackers cut to look like animals and at each place was a red juicy apple.

When the party was over there were beads and bright-colored papers to put on long strings. Some of the children, trying to do this, grew drowsy and were taken to the nursery for a nap, but though Paul's eyes grew heavy, he fought sleep with a determined energy which soon vanquished the sandman. He had no idea of missing any part of the unusual day.

Several of the older children remained in the play-room and were amused a while by watching the snowflakes which had been falling since early morning. Then there were stories, and for the first time since his mother's death Paul heard several of the old favorites which even his father did not know. This, the crowning glory of an enchanting day, was broken into by some of the parents calling for their children, and by five o'clock, much to Paul's delight, he was left alone with the teacher.

After telling the maid she was expecting a business caller and asking her to make all the arrangements with whomever came for the boy, she took Paul into her sitting-room.

The child accepted an invitation to sit on her lap and, being asked his opinion of the kindergarten, replied: "I fink it's fine. You know lots of stories, don't you? How'd you wike to be a gran'muver?"

Paul had been charmed by Mrs. McMurfy's kindness, but this day had displaced her, and he had been many times on the verge of asking his new divinity the all-important question; but the minute it was out he was sorry. The lady looked as if she was going to cry. In his haste to set matters right he asked:

[CONCLUDED ON PAGE 31]

"Murmuring of Spring"

M. GREENWALD,

Valse de Salon

INTRODUCTION
Tempo di Valse

Composer of
"Stilling the Storm," Meditation;
"Soul's Awakening," Reverie, etc., etc.

The musical score is written for piano and consists of 12 systems of music. Each system contains a treble and bass staff. The piece begins with an introduction marked 'Tempo di Valse'. Dynamics include *mf cresc.*, *sf*, *mf*, *Fine.*, *rit.*, *a tempo*, and *p*. The score concludes with a double bar line and a section marked *D. S. al Fine.*

Copyright, MCMX, by LEO FEIST, Feist Building, New York
International Copyright Secured and Reserved

D. S. al Fine.

CORNISH

Sent to You
for a Year's
Free Trial

Cornish Instruments for real merit, are unexcelled by any other, whatever the price, or name or reputation.



We will send direct from our Factory, any Cornish piano or organ that you may select from our catalog, on any terms of payment that you may choose with the distinct understanding that if the instrument does not come up to your fullest expectations you will be under no obligations whatever to keep it, and that the

Trial Will Cost You Absolutely Nothing

If the instrument does not prove better value for the money than you can get anywhere else—if it is not as good an instrument as you can buy for one-third more than we ask—if at any time within a year you feel that you have not a good bargain, send it back; we won't find one word of fault with your decision, and you will not be one cent out of pocket for freight or for use of the instrument.

Two Years Credit if Needed

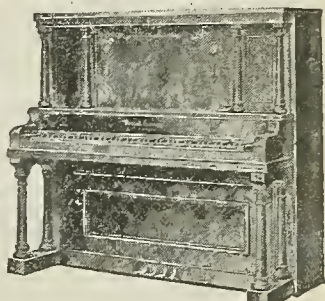

We Save You \$100 and More On a Piano

We Give You a Legal Bond of Indemnity

Easy Terms

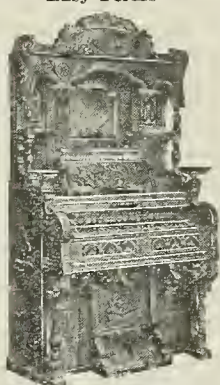

Buy On The Cornish Plan—Save One Third

which holds us strictly to this offer. You risk nothing. We assume all responsibility, because we know all about the great beauty of material and workmanship in Cornish pianos and organs and we know all about the pure, sweet, rich tone quality of our instruments and we know what a quarter of a million satisfied purchasers think of them.

If you keep the instrument it will cost you the Rock-Bottom Factory Price, not one cent more, and you will receive with it our Bonded Guarantee which insures the instrument for 25 years against defect in material or workmanship.

Send For The Cornish Book

Don't think of buying before reading it. It is the handsomest piano and organ catalog ever issued. It explains things you ought to know whether you buy from us or not and it is yours for the asking. Write for it now and please mention which you are interested in—piano or organ.

CORNISH CO. WASHINGTON, N. J.
Established Over Half A Century.



Reg. U. S. Pat. Off.

I make all sorts of clear glass for all sorts of uses; each the best glass for its particular purpose.

For my Pearl Glass lamp-chimneys—that bear my name, Macbeth—I make the best glass ever put into a lamp-chimney.

These chimneys are clear as crystal, and they won't break from heat; proper shapes and lengths, and they fit.

I'll send you, free, my lamp-chimney book, to tell you the right chimney for any burner. Address

MACBETH, Pittsburgh.

50ct. SHEET MUSIC

15 CTS. EACH, POSTPAID

SONGS—Words and Music for Piano or Organ

- | | |
|--------------------|---------------------------------|
| Rainbow | Carry Harry Harry, Big Hit |
| My Pony Boy | I've Got Rings on My Fingers |
| Red Wing | Down in Jungle Town |
| Just Some One | I Wish I Had a Girl |
| Red Head | Yip-I Addy-I-Aye |
| Star of the East | By Light of Silvery Moon |
| Oh! You Kid | Sweet Bunch of Daisies |
| Senora, A Dandy | Silver Threads Among the Gold |
| Smarty, Kid Song | My Wife's Gone to the Country |
| Baby Doll | That's What the Rose Said to Me |
| Dreaming | Put on Your Old Grey Bonnet |
| Are You Sincere | Way Down in Cotton Town |
| No One Knows | Isn't That Enough For You |
| Honey Boy | I Remember You |
| Daisies Won't Tell | Napaneo |
| Jolly Lee | I'm Bringing Up the Family |
| Beautiful Eyes | Be Jolly Molly, March Song Hit |
| Always Me | Lonesome |
| That Italian Rag | The Land of To-Morrow |
| Garden of Dreams | Cubanola Glide, Great Hit |
| | I Love My Wife But Oh You Kid |

INSTRUMENTAL—Music for Piano or Organ

- | | |
|---------------------------|--------------------------|
| Kiss of Spring, Waltz | Wild Cherry, Rag |
| Sicilian Chimes, Reverie | Frog Legs, Rag |
| Let Er Go, March | Love Sparks, Waltz |
| Rainbow, Two Step | Moon Winks, Three Step |
| Star of Sea, Reverie | Maple Leaf, Rag |
| Morning, Cy, Barn Dance | Beautiful Star of Heaven |
| Turkey in the Straw | Ben Hur Chariot Race |
| Red Wing, Two Step | Kerry Mills Barn Dance |
| Red Head Rag, A Hit | College Life, Two Step |
| Curly, Two Step (New Hit) | Rose Song, Reverie |
| Burning of Rome, March | Princess Royal, Caprice |

Our Music is the same—in every particular—as you purchase in any Music store—the only difference being the price.

THE MYREX COMPANY, 248 West 36th Street, NEW YORK

"The Cheapest Music House on Earth"

Send 2c. Stamp for "Money Saving" Catalog

The Wrong Miss Jane

By Newton A. Fuessle

Illustrated by C. F. Neagle



BILLY CABEEN, lawyer and former Yale foot-ball star, wrapped in the soft folds of his dressing-gown, extended his slippers toward the hard-coal fire sleeping warmly on the grate and thanked Providence that there was such a thing as solid comfort in New York City on a cold night torn by the blustering winds of December.

Suddenly there was a knock at his door. It was the hand of fate, in the guise of a special-delivery letter-carrier, who brought a letter from Miranda, Billy's cousin, who attended the select seminary for girls at Wilkesbury, New York.

Now, girls at boarding-school are not given to despatching special-delivery letters unless something important is fretting their minds; wherefore Billy lost no time in breaking the seal. When he had read the missive, he gave a long-drawn whistle.

"I am going to ask you to do me a great favor," ran the letter. "My chum Jane, whom I've written you so much about, arrives at the Grand Central Station at ten o'clock to-night. She will have to wait till twelve for her train home to Hartford. Please be there to meet her and see that she doesn't get lonesome between trains. You've never met her, but that won't matter. I'm not telling her about writing to you, for she'd think it too unconventional. So please pretend that you've met her by pure accident and that you've recognized her from pictures I've shown you. She has seen many pictures of you and will know you at once. I wish I had a picture of her to send you. But you can't miss her. She will wear a dark gray suit, black furs, gray suedes, a black pompon, a pepper-and-salt veil and carry a silver-mounted hand-bag. She is very beautiful. Her complexion is delicious. Her eyes are gray and heavily browed. She is of medium height and you'll find her a perfect dear. I hope this letter will reach you in time. Now be a good cousin and do as I've asked. Affectionately, Miranda."

To Cabeen's face mounted a look of bewilderment. No doubt Miranda had written him reams and reams about Jane, yet to save his life he couldn't even recall her family name. How like Miranda to forget all about mentioning this important detail! Heavens! It might be anything from Jane Abbott to Jane Zandt!

A pretty figure he would cut searching the vast station for a girl named Jane, described in feminine riddle-words. Suedes, pompons, pepper-and-salt veil! The words were worse than Arabic. Smiling indulgently at Miranda's thoughtlessness, he reached for his unabridged dictionary. At that moment the clock on his mantel struck ten.

Ten o'clock! Already Miranda's lovely chum was alone in the great friendless station. Miranda would never forgive him if he failed her. He threw off his slippers and dressing-gown, rammed his feet into his shoes, paused in front of the mirror to adjust hair and cravat, flung into his great-coat and dashed down into the street. On Fifth Avenue he leaped into a taxicab and went whirling toward the scene of his quest.

As visions of lovely maids went weaving in endless procession through his brain, he was conscious of a delicious tingling of his blood at thought of the novel adventure on which he had embarked. Delicious complexion! Would it be the glowing pink of the rose or the softer hue of the olive? "Delicious" would fit either. Yet, rose or olive, all the romance in his soul, all the spirit of adventure which had smoldered beneath the dry details of his pursuit of the law, were aroused by Miranda's letter.

The taxi came to an abrupt pause and Cabeen darted into the station entrance. To have seen the hand of fate, in the guise of a special-delivery to the station, his face formal and impassive, one would never have guessed that he was a prey to strong excitement. His eyes began to rove the great room and, of a truth, he felt anything but assured as he wandered about among the hundreds of travelers and wondered whether he would be able to single out the girl of his quest. More and more hopeless seemed his task as the seconds raced on into minutes. On every hand he beheld comely young women. Fortune seemed to have singled out this very night to deflect hordes of beautiful girls into the Grand Central Station.

Suddenly he found himself staring full into the eyes of a beautiful girl. Gray, he realized vaguely, was the dominant note of her attire. And gray, he recalled nervously, was to be the chromatic distinction of the girl's garb whom he sought. He also realized confusedly that certain peculiar decorations were attached to her coat. These he mused must be "pompons." And her complexion was all of delicious. Billy pulled himself resolutely together, approached her, doffed his English fedora and quite unconscious that he was blundering dismally, said:

"I beg your pardon; but are those tom-toms?"

At first a startled look came into her eyes, then it melted into a smile and she gaily laughed at her questioner. She turned to a group of people behind her, spoke a few low words to them, and they all looked over in Billy's direction and laughed, too. Billy was dumbfounded, desolated, mortified. He

could feel his ass' ears growing bigger every second. It was too much. He turned and strode savagely in the opposite direction.

His first impulse was to flee the premises, give up his quest in confusion, and return home and write Miranda precisely what he thought of her for getting him into this unparalleled mess. But his native stubbornness came to the rescue and he resolved to return warily to the job. He had been idiotically impulsive, that was all, he mused. He should have looked for the black furs and the gray eyes. He recalled now, but too late, that the girl he had accosted had owned a pair of the bluest eyes he had ever seen. It was these which must have had their mesmeric influence on him, luring him upon thin ice.

Even in the most halcyon days of Billy Cabeen's athletic triumphs at college he had never been known as a "fusser," and two or three incipient love affairs had died early and natural deaths. Hence such things as pompons, suedes, pepper-and-salt veils blocked the course of his quest as formidable barriers. He longed despairingly for a moment's counsel with a *modiste*. But he could do nothing, save trust to Providence to lead him to the side of her who was shrouded in the effective mystery of the weird phrases of Miranda's letter.

But again his pulses quickened as he beheld a lass of medium height, wondrous complexion and wrapped



"What if she were the creature of his quest?"

in dark furs. It was Jane! There could be no doubt. She was gazing hesitantly about her, timid and alone. Still dazed by his first disastrous essay, the youth, however, took both courage and a step nearer her. But just as he was making ready to greet her, she wheeled suddenly and cast herself into the arms of an elderly gentleman. By the exchange of their greetings, Billy knew that they were father and daughter.

Cabeen congratulated himself warmly on the fortuitous arrival of the girl's father, which had spelled his lucky escape. Already it was eleven o'clock. Time was speeding and Jane was alone. Something must be done.

Once more he looked about him for young women boasting unusual beauty, but no one looked the way he had pictured the fair Jane.

At length he perceived a dazzling vision of a girl. What if this were the creature of his quest! Slowly he became aware that height and eyes and garb and complexion fulfilled precisely the specifications in Miranda's letter. Moreover, a certain divination told him it was she, and, scorning the recollection of former disasters, he approached her boldly.

"Good-evening," said Cabeen. "Why, upon my word, I should have known you anywhere after all of my cousin's descriptions of you."

"How do you do?" she rejoined quickly, the white of her teeth flashing through a smile. Then she extended her hand, and the touch of her gloved hand went warmly through the young man's blood.

"I'm glad you recognize me," he answered. "A strange coincidence," he added, mindful of Miranda's instructions, and sending a mute prayer to heaven for forgiveness for the necessary falsehood, "that we should both happen to be here to-night. What a kind fate it was that led me here!"

"It is a great pleasure, I'm sure," murmured the girl.

"You are waiting for your train home, I suppose," pursued Billy.

"Yes, the one that goes at twelve o'clock."

"Then why not come to a near-by restaurant and have a bit of supper," asked Billy, consulting his watch.

"It's very good of you. I'd like to ever so much," she said.

In half a minute the two were inside a taxicab and three minutes later, to be quite exact, they were at the restaurant. An orchestra was playing, there were crowds of evening diners, lights blazed and the head-waiter grandly ushered the two arrivals to a table for two.

"And now," smiled the youth, "I shall have to ask you to tell me your last name. Cousin Miranda, after the fashion of girls at Wilkesbury Seminary, I presume, has always referred to you only as Jane. It's horrid of me to have to ask. Personally, I should be content with Jane alone, but for the sake of conventionality—"

Billy stopped abruptly. His words froze on his lips as he beheld the look of utter bewilderment which had risen to the girl's face.

"You—you—must have made—a horrible mistake," she said weakly. "My name isn't Jane. I—I—don't know anybody named Miranda. And I've never been at Wilkesbury Seminary in my life."

"You don't mean," he stopped, astounded, then rushed on for an explanation, "that you are—that you aren't the girl Miranda has written me so much about!"

The girl nodded dismally. "I must go—I must leave here at once," she added. "It's perfectly horrible—idiotic—this mistake I've made—you've made—both of us have made!" Her words ended with a gasp.

"I am frank to say," smiled Billy, with returning courage, "that it's the most sensible thing I've ever done in my life."

The girl smiled in spite of herself. "But I must go," she insisted firmly.

"Please don't," he protested, overcome with chagrin as she pushed back her chair diffidently from her untouched fare.

"I shall never be able to forgive myself for this terrible mistake," she moaned.

"Please don't blame yourself," he said desperately. "It was my fault entirely. Listen," he added, suffering incalculable tortures at thought of this vision vanishing so soon from his sight. "Let's analyse the situation and then, if you insist on going, I'll take you back to the station, leave you where I found you and will promise to try and blot the incident from my memory."

She paused, hesitantly, but Billy went on: "Please eat while I'm talking." And to his huge delight, her diffident fingers sought her fork. "Here is the plot," he continued, "and may heaven bear witness that I'm telling the truth."

He told the story of Miranda's letter, then added: "That is all. When I saw you I was positive that you were Jane and went on with the program. I beg your forgiveness a million times for my mistake."

"Then Jane must still be at the station, alone," replied the girl. "It is your duty to return there at once."

And before Cabeen could weigh his words, he blurted: "I wouldn't miss half an hour with you for all the Janes in the world!"

"Don't," objected the girl. "You are adding—"

"Insult to injury?" questioned Cabeen in despair.

"I wasn't going to put it exactly like that," she replied with a smile—a smile which gave Billy a ray of hope.

"I knew by your tone that you weren't going to say that," he rejoined.

"It is good to be with folks who can tell things by one's tones," answered the girl, half-banteringly.

"I must ask your forgiveness again," he continued. "I've been talking to you all this time without even introducing myself. My name is Cabeen—W. H. Cabeen—Billy Cabeen for short. And now will you tell me—"

"I can't," murmured the girl, anticipating his question.

"Why not?" he demanded, again in despair.

"You mustn't ask me," and her voice was soft as she spoke. "Please don't think me too ungenerous. And please don't ever mention this mortifying mistake to anybody. You won't, will you?"

The youth agreed.

"Thanks, so much. And now, please let me go?" she queried.

Billy's thumping heart sank like lead. "It can't be so wrong—so very wrong," he murmured, without answering her question, "for you to finish your supper. Some strange fate has thrown us together. Why must we let the city widen between us so soon, and our paths diverge perhaps never to meet again?"

There was something magnetic in his voice, his manner, that made the girl's resolution waver for a moment, and she remained motionless in her chair, held by the caress of her companion's gaze. And suddenly, before he could realize what he was saying, quick words poured from his lips.

"Before you go," he went on hastily, "you must let me tell you something more. I cannot let it be unsaid. I would never forgive myself. All my life I have known in some inexplicable way that sometime I should meet that wonderful girl of my dreams whom I have worshiped ever since I was a boy, and will you believe it when I tell you that I have met the girl of my dreams?"

Cabeen paused and looked earnestly at the girl,

[CONCLUDED ON PAGE 31]



THE HOUSEHOLD



Five-Minute Recipes

THESE recipes will be found invaluable to the housewife when company drops in unexpectedly to tea.

FRIED BANANAS—Six bananas, two tablespoonfuls of butter, two tablespoonfuls of flour and two tablespoonfuls of powdered sugar.

Put the butter in the pan, keep very hot, but not boiling, for five minutes. Peel the bananas, cut in two lengthwise and roll lightly in flour. Put the slices into the butter and fry brown on both sides. Place on hot dish and sprinkle with the sugar. Serve hot.

BREAD SAUTÉ—One thick slice of bread, two tablespoonfuls of butter, two tablespoonfuls of grated cheese, one half cupful of cream, a pinch cayenne pepper and two tablespoonfuls of chopped ham.

Cut the crust from the bread, put the butter in the pan; when hot, brown the bread on both sides. Take it out and put into ham and cheese and cream. Add the cayenne pepper. Mix well together and when hot, spread the mixture on the cooked bread.

BRAISED ONIONS—Two tablespoonfuls butter, four onions, salt and pepper.

Melt the butter in pan, add onions peeled and cut into strips. Cook until onions are tender and a light brown. Season and serve at once.

GREEN PEPPERS SAUTÉ—Green peppers, two tablespoonfuls of butter or olive-oil, salt.

Slice the peppers and remove the seeds and pulp. Beat the butter or olive-oil and add the peppers. Cook until they are brown and tender. Season and serve with cold meats.

CORN OYSTERS—One pint of corn pulp, two eggs, one teaspoonful of salt, one saltspoonful of pepper, two tablespoonfuls of flour and butter.

Mix the corn, beaten eggs, salt, pepper and flour thoroughly and fry in small cakes in melted butter. Moisten the corn with two tablespoonfuls of milk before cooking.

TOMATO-CUTLETS—Tomatoes, bread-crumbs, two eggs, salt and pepper, olive-oil or butter.

Cut firm, ripe tomatoes into thin slices, season and roll them first in bread-crumbs and then in eggs and then again in crumbs. Cook in oil or butter until light brown and serve hot.

Three Spinach Dishes

CREAMED SPINACH—Cook, drain and chop the spinach in the usual way. Season to taste, return to the fire and stir in two tablespoonfuls each of butter and cream.

SPINACH CUPS are substantial and dainty to serve at lunch in place of meat. Measure the spinach before cooking and for one peck allow the yolks of five or six hard-boiled eggs. Cook the spinach as directed for other dishes, drain well, chop fine and season with salt, pepper and a tiny grating of nutmeg. Mix lightly in the smoothly-mashed yolks of eggs and press into small buttered cups. Keep hot over hot water until time to serve, then turn them out carefully on a platter, sprinkle lightly with lemon-juice or vinegar and serve with cream sauce.

Another pleasing luncheon dish is made thus: Cook the spinach as usual and have ready rounds of crisp hot buttered toast. Drain and chop the spinach, season well, spread it over the toast and on each round drop a nicely poached egg. Put a dust of salt and pepper on each egg and a small bit of butter. Serve at once.

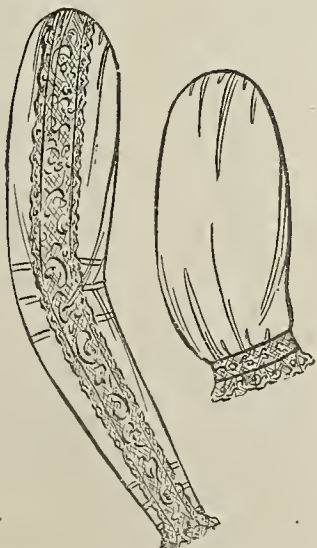

An effective way to remodel a short sleeve on a lingerie waist

About the House

Save the pieces of broken window-panes, take to a glass-cutter and have him cut them down to cover little pictures and photos. Bind together with passe-partout picture-binding to harmonize with other furnishings. This costs but a few cents and is pleasant employment for busy fingers.

Japanese cement is a strong colorless paste quite easily made at home. Mix some rice-flour to a thick paste with cold water, then pour over it boiling water to reduce it to the proper consistency. Pour it into a saucepan and let it boil briskly for one minute, then turn into small bottles or jars.

A great many cooks prefer to boil puddings in a mold, rather than in a pudding bag. When this is done, a piece of buttered white paper that will entirely cover the top should be laid in place and a piece of doubled cheese-cloth or butter muslin should be tied down tightly over the top. This will effectually keep the water out. After using, the pudding-cloth should be put to soak in boiling hot soda-water and left there until the water begins to cool; it should then be well washed in soda-

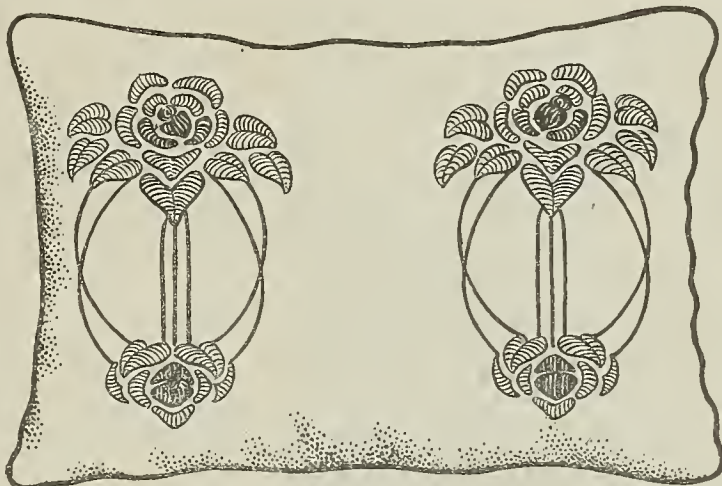

No. 59—Cushion of Gray Crash

The embroidery is carried out in three shades of dull rose and green. With the thread we send a diagram showing the placing of the colors. The centers of the flowers are French knots worked in brown.

Stamped on Gray Crash (Twenty-Four by Sixteen Inches) 70 Cents
Perforated Pattern of Motif 20 Cents
Embroidery-Cotton 45 Cents

This cushion may be ordered from the Embroidery Department, Farm and Fireside, Springfield, Ohio. In ordering, write name and address plainly. Remit by money-order, currency or stamps.

water, rinsed in clean hot water, then in cold, and smoothly ironed before putting it away. Needless to say, it should be kept strictly for this one use.

To make the carpet-broom both tough and pliable, dip it in boiling hot suds for a minute or two once a week. It will last longer, sweep better and be easier on the carpets or rugs. A new broom or whisk should always be steeped in warm water before using.

A saucepan that has been stained by its contents burning while cooking is easily cleaned in this way: Dissolve quite a quantity of soda in a little hot water, put it into the saucepan, fill it up (as far as the stain extends) with cold water and let it stand for two or three hours. Then place it over the fire and let the water come to boil. Keep it simmering five or ten minutes, then rub off the burned particles and wash thoroughly.

Remodeling Short Sleeves

A GREAT many times a good waist is discarded because it has short sleeves and the owner has grown tired of them. There are many attractive ways to make over short sleeves and one exceptionally good one is given herewith.

In making them over, these general directions are the rule: Rip your old sleeve carefully apart and press well. Provide yourself with a pattern of a one-seam close long sleeve which has been cut to fit your arm exactly, for in making over there must be no mistakes.

In the sleeve here pictured there was no left-over material to make it, so it was split and a wide insertion of lace run the entire length. A close sleeve was then cut, and the pieces from each side of under the arm were added to make sufficient length, the piecing being made under a tuck, and two tucks added to give a better effect. A scant ruffle of very narrow Valenciennes lace might be added on each side of the lace strip, but it adds materially to the trouble of laundering the waist.

Rhubarb Favorites

RHUBARB BLANC-MANGE—Cut the rhubarb into small pieces and cook until tender, but not broken in a rich sugar syrup. Drain off the syrup carefully and let the rhubarb get cold. Make blanc-mange after the usual rule, only allowing three and a half cupfuls of milk instead of four to four tablespoonfuls of corn-starch. When it is done add half a cupful of hot strawberry-juice from preserved or canned fruit. Mold in small cups. When firm turn each one out carefully on a pretty china dessert plate, arrange the pieces of rhubarb around neatly and garnish with whipped cream.

RHUBARB-BUTTER—Wash and chop the rhubarb fine. To each pound allow one pint of sugar and just enough water to keep it from burning. Let it simmer very gently for an hour or longer. The time required will depend upon the age of the rhubarb. Keep an asbestos mat under the preserving-kettle and stir the rhubarb frequently. To vary this delicious butter add half an orange pulp and a delicious marmalade will result.

RHUBARB-FRITTERS—Cut rhubarb into two-inch lengths and cook until tender (but not broken) in a rich sugar syrup. Let lie in the syrup until cold, then drain each piece carefully, place two or three together and dust thickly with powdered sugar. Make a batter with one cupful of milk, two beaten eggs, and one and one half cupful of sifted flour in which one small teaspoonful of baking-powder and one teaspoonful of sugar have been sifted. Add the milk and the sugar to the eggs with a pinch of salt, then the flour mixture. Mix thoroughly, then dip each little bundle of rhubarb in the batter and fry in deep hot fat. Drain on unglazed paper, roll in granulated sugar and serve at once with the syrup drained from the rhubarb.

RHUBARB TUTTI-FRUTTI CAKE—Make a short-cake by any preferred recipe, split and butter it quickly, and spread at once with a filling made as follows: Cook together for five minutes two cupfuls of rich thick stewed rhubarb and one cupful of mixed stoned dates and raisins chopped fine. Spread over each layer while both cake and filling are hot and put a thin layer of whipped cream on top of each layer of fruit before covering with the next layer of the short-cake. This dessert should be served at once with plenty of good whipped cream or with plain thick sweet cream and sugar.

If You Dread WASH DAY—Read This—

You can do in one hour, what now requires a whole day. 1 hour of easy turning of a wheel while you sit. Clothes will be whiter will last longer. Use an

O. K. Washer

Large tub of red cypress, will never warp, cannot wobble. Lid is steam-proof, keeping water hot. No strength needed to operate. Simple Roller Gearing makes it easy for child to operate. Our guarantee with each.



H. F. Brammer
Mfg. Co.
1452 Rockingham
Road
Davenport, Ia.

Write For
Free Book

The family that eats plenty of

Quaker Oats

is a healthy, rugged family.

The most popular food in the world because it does most and costs least.

Test "IMPERIAL" 30 an "IMPERIAL" Days In Your Own Home at OUR RISK



If it does not prove the best cooker, baker or ever saw, send it back at our expense.

Direct from factory to you at WHOLESALE PRICE.

Freight prepaid. Has exclusive features not in any other range—such as Stone Oven Bottom, Odor Hood, Oven Thermometer, Ash Sifter, etc., etc.

Easy credit terms if wanted. Write to-day for Free Catalog and prices.

The Imperial Steel Range Co., 868 State St., Cleveland, Ohio

Day After Day

One will find

Post Toasties

a constant delight.

The food is crisp and wholesome and so dainty and tempting, that it appeals to the appetite all the time—morning, noon and night.

Some folks have pronounced Post Toasties the choicest flavoured bits of cereal food ever produced.



Popular pkg. 10c.
Family size 15c.

"The Memory Lingers"

Postum Cereal Co., Ltd., Battle Creek, Mich., U. S. A.



OUR YOUNG FOLKS' DEPARTMENT

CONDUCTED BY COUSIN SALLY



The Daughter of a Mason

By Mary Minor Lewis

THE cool white farm-house with its green shutters and vine-covered porch stood half a mile back from the county road. Away to the left stretched meadows of blossoming pink clover from which the place took its name—"Cloverfields."

On the doorstep of the farm-house, book in hand, sat a little girl, her faithful dog by her side. She read tales of the Crusades—of brave Richard Cœur de Lion, of tournaments, battles, castles besieged and fair ladies rescued by brave and devoted knights! So peaceful was the scene, so still and warm the day, that it seemed almost impossible to believe that the country was at war and the "Old Dominion" a battle-field.

Inside the house at an open window Mrs. Huntington sat sewing. Presently she took from her work-basket a much-worn letter and read it. As she did so, tears came to her eyes and fell upon her work. Looking up from her book, Helen saw her mother's tears and hastened to her side.

"What is it, mother dear?" Helen asked.

"I was reading over your father's letter, child, and the tears would come. God knows I try to be brave and believe that he will come back safe to the old home when this cruel war is over. But the time seems so long. Helen, and I never feel strong now. He has been gone over a year and the letters come so seldom—I'm very anxious. My heart is heavy to-day, but I know that I should be thankful that you and I are well and that we have not suffered as so many have from the depredations of hostile bands of soldiers. At least, the home is safe."

"I could not bear it if anything happened to this dear old place!" cried Helen. "Next to you and father, I love 'Cloverfields' better than anything in the world!"

"So do I," answered her mother, "for I was born here, and here I have known the happiest days of my life."

"Come," said Helen, "let us tie up the honeysuckle and trumpet vines on the porch. Let us keep everything just as father would like to see it—if he should come home!"

Together Mrs. Huntington and her daughter went into the vine-clad piazza.

"Perhaps, who knows?" mused Mrs. Huntington. "He may come almost any day."

The vines being trained to their satisfaction, they went across the lawn to the garden. Here Big Jim, an old colored man, was working among the gay flower-beds. Birds sang, bees droned among the bright blossoms and a great stillness and peace lay over the smiling Southland. Then, far down the road, which wound like a ribbon across the distant fields, there appeared a cloud of dust.

They were startled by Carlo's barking and hastened toward the house. Down the turnpike the heavy cloud of dust was approaching! Nearer—and they heard the clank of arms, the rattle of spurs and the tramp of many approaching horses' feet, mingled with the loud, harsh voices of soldiers. Swiftly—with blanched faces, a nameless fear at their hearts—mother and child passed through the garden gate and hurried into the house.

A party of blue-coated soldiers was riding into the lawn, led by a burly Irishman with a sergeant's straps on his shoulders. Dismounting, they entered the house uninvited, distributing themselves through the clean, cool rooms with much jangling of spurs and loud talk and

laughter. Mrs. Huntington remonstrated with their leader while Helen looked anxiously at the soldiers.

"I will have your men served with refreshments on the lawn and I will have your horses fed," said she, "only, I beg of you, do not despoil my home!" But the sergeant only smiled and gave no heed to her request.

The dining-room was raided, the pantry, the kitchen, the dairy, then the "smoke-house" in the yard where the hams and bacon were kept, the hungry soldiers eating all that they could and packing into their saddle-bags whatever might be of use to them on the march.

Helen stood against the wall in the lower hallway and watched the pillage of her home dry-eyed, but her small face white as the dress she wore. Presently she heard a soldier say to his leader:

"I hear that this is Captain Huntington's house. It was under this roof that three escaped rebel prisoners were kept concealed while we scoured the country for miles around in search of them!"

"Ha! exclaimed the sergeant, "then we will burn the house to the ground! It shall harbor no more enemies to the Union!"



"She raised the apron above her head, crying, 'Stop! Will a Mason see a Mason's home destroyed?'"

For a moment, only, Helen stood still, while the dreadful truth sank into her mind. These soldiers meant to burn the "Cloverfields" house! By sunset the dear old home would be nothing but a heap of ashes!

With flying feet, she rushed up the stairs to her mother's room. She knocked, but there was no answer, so she pushed open the door and rushed in. Her mother lay upon the floor with closed eyes and face as white as death. The excitement and fright had been too much for her—she had always been very delicate—and she had fainted.

Dashing some cold water into her face, the child ran to the window and raised it. The fresh air flowing in somewhat revived the unconscious woman and she stirred slightly. The little girl turned again to the window. Already men were carrying bundles of straws and sticks to the corner of the house, where the sergeant stood with lighted torch.

"What shall I do?" she cried brokenly. "Oh! what can I do?"

And then suddenly she remembered something her father told her long ago—a story about an order that he called the "Masons." And she remembered he said that if a Mason were in trouble, every other Mason who knew about it would feel in honor bound to help him or any one belonging to him. And then she remembered her father's Masonic apron, always kept in the drawer of the desk. She flew into the next room and opened the desk drawer.

"Where is it? Oh, where is it?" she cried. And then, under some folded papers, she found it. Unrolling the apron as she ran, she held it before her as she descended the stairs and reached the top step of the piazza.

The wind blew the dark curls back from her pale face. Her eyes were bright as stars and her voice rang out sweet and clear as she raised the apron above her head, crying, "Stop! See! I am a Mason's daughter? Is there no Mason among you? Will a Mason see a Mason's home destroyed?"

A silence fell upon the rough crowd. Several hands went involuntarily to caps, and more than one homesick man's eyes filled with tears.

"God bless the bonnie lassie!" cried a red-haired Scot. The sergeant crossed the open space and silently gripped the hand of a brother Mason. "And it's meself that's thinkin' you have a brave heart," he said, turning to Helen. "And right proud might any Mason be of such a daughter!"

"Hold! men," he called. "Spare the house! It is a Mason's home. A Mason's a Mason, whether he wears the Blue or the Gray!"

"Three cheers for the Mason's brave little daughter!" cried a blue-eyed youth. And as the rough soldiers raised their hats and cheered her, Helen sank down upon the doorstep, buried her face in the Mason's apron and sobbed for very thankfulness!

Late that night, long after all the soldiers had gone, there came a tap at the shutters of the sitting-room, which opened upon the porch. Startled, Helen and her mother sprang to their feet and tremblingly approached the window. The sound of a beloved voice caused the shutters to be quickly thrown wide and—bearded and bronzed, in a uniform of shabby gray—Helen's long-absent father rushed into the room and clasped both wife and child tenderly in his arms.

Cousin Sally's Letter About Holland

DEAR BOYS AND GIRLS:—

Do you remember my telling you about a club in which I am interested, called "The Busy Bees?" I am sure I told you about it and that I was an honorary member. Well, anyway, some of the girls were asked by their teachers to write a composition on Holland, and one day Marjorie (the president) came running in to ask if I would give a little talk about Holland at their next club meeting. Now, when Marjorie comes and throws her arms around my neck and asks me in that soft voice and with such a wistful look in her pretty eyes, I haven't the heart to refuse, no matter how busy I may be.

A week later the meeting was held and it was a big success. I was extremely pleased when the girls said my talk on Holland had been of real help to them. I had a splendid selection of picture post-cards of Holland and Marjorie said that it seemed like a real lecture with magic-lantern views.

The girls enjoyed the "lecture" so much that I am going to tell you part of what I told them. I will describe a few of the pictures as interestingly as I can.

In Holland it would seem that the sea and land were ever at war with each other—the land fights for its existence and the sea for its supremacy. To prevent the flooding of the low lands, dikes have been built on the coast and there are few places in Holland where sea-dikes are not necessary. It seems as though the early settlers of Holland sailed there on boats and built dikes around them, doesn't it? With its many winding canals, its dikes, endless windmills, it is a most picturesque country. Imagine living in a quaint little house with your room looking out on a winding canal where boats ply back and forth all day long—and such quaint boats! Just as quaint and old-fashioned as the people.

Look at this picture of three little Dutch maidens and notice the way they are dressed. How tight fitting their little bodices are, and how typically Dutch are the sleeves! The skirts, you see, are the bulgy kind like those found in all Holland, and on their feet are little wooden shoes. The Dutch girls are good to look upon, for they have

complexions that any girl might envy—cheeks red as apples, hair golden and silky, and eyes as clear and blue as the sky.

The women of Holland are always scrubbing or sweeping or cleaning or patching. If you should walk through a street, let us say a street in Amsterdam, you would see groups of women gossiping and laughing together and others scrubbing the pavement or polishing the brass trimmings on the doors. They scrub anything they can lay hands on, for the Dutch are noted the world over for their cleanliness. The brass doors look almost like gold as they glitter and shine in the sunlight. When entering the house the wooden shoes must be left at the door so there will be no danger of them soiling the matting.

Of course, you want to know what the interior of a



A characteristic scene in one of the farming districts of Holland

Dutch house looks like, and this next picture will give you a good idea of one of the rooms. How cozy and homelike the blue-tiled fireplace looks, with the newly-polished brass and copper cooking-utensils hanging around it. In some of the old houses there is but one main room which serves as a kitchen, living-room and bedroom. The bed resembles a bunk in a ship, for it is built in the wall.

A noted writer once said that Holland was a land of artistic patches and I think he is about right. The men's shirts are patched and patched, until the whole garment has practically been made over.

The next picture shows a boat, laden with cheeses, plowing its way through one of Holland's picturesque canals. Suppose we imagine ourselves on board with the captain, a good-natured-looking man, wearing the inevitable patched shirt and baggy brown breeches. Hardly before we know it we are far away from the quaint town and are sailing out into the country. Can't you picture how fresh and sweet and clean the country looks, with its vividly green meadows broken here and there by little winding canals, which glisten and sparkle in the golden sunlight; the windmills, with their arms silently revolving in the light wind, and close by some old-fashioned farm-houses, with their red tiled roofs, suggesting everything that is homelike and cozy. Here and there are groups of little trees, and under them spotted black cows are brousing in the grass and solemnly chewing their cuds. And look! away over in the meadow comes a farm boy carrying pails of foamy milk which are suspended from a yoke across his shoulders.

But see! we are approaching a little bridge over the canal and before we can pass we are stopped by the toll-man who stolidly lowers a wooden shoe suspended by a string from a short fishing-rod. Our boatman places in it the requisite toll. The bridge is raised and we pass on.

Write soon and tell me if you liked my letter.

Boys and girls wishing a club button should send five cents to Cousin Sally's Club, care FARM AND FIRESIDE, 11 East 24th Street, New York City. State age when writing. Faithfully always, COUSIN SALLY.

Our Girls At Home

BOOKS FOR GIRLS

Questions From Girls

Please Advise Me

"I am seventeen years of age and know a young man that I like very well and I think he likes me. Would you advise me to invite him to my home and encourage his affections?"

You are a little young to think seriously of any young man, but I see no reason why you cannot be friends. It would be all right for your mother to ask the young man to call. Or, why not give a little party and invite him? In this way he will surely ask if he may call on you some evening.

Acknowledging an Introduction

"When introduced, how should I acknowledge the introduction? Also, please tell me how to begin a conversation? Must it be by mention of the weather?"

All that is necessary is to repeat the name of the person to whom you are introduced, with a pleasant bow and smile. If you choose, you may add, "I am very glad to meet you."

There is nothing original in speaking about the weather, but perhaps it is as good a topic as anything else. If you have nothing to say, wait for some one else to begin talking.

Parents Object

"I am engaged to be married and most unhappy because my parents object to my fiancé. He is a man of excellent character and education, and his business circumstances are exceptionally good. My parents have asked me to choose between them and my lover, and I am heartbroken. I am twenty-two years old."

It seems to me that you are old enough to know your own mind, and if the young man is in every way worthy of your hand, I see no good reason for your parents' objection to your marriage. Probably once you are married, they will yield and everything will be happy again.

About a Boy Friend

"I am sixteen years old and have a boy friend about the same age. He is at sea, and last summer he sent me cards and a letter occasionally. I think he likes me quite well, but I don't care to think of him in any other light but that of a friend. He urges me to answer his letters and really forces his friendship, and I am at a loss to know what to do. Will you please advise me?"

I see no reason why you could not send him a card once in a while if he is a friend you have known for some time. If you write letters, be careful that they are not in any way personal. Should his messages grow serious, then stop the correspondence if you do not care for him. Anyway, you are entirely too young to accept attentions from young men.

Perfumed Note-Paper

"Is it good form to use perfumed note-paper?"

No, not as a rule. But if it is used, the perfume must be very delicate. A thin envelope filled with powdered orris root and placed in the box will give just the right flavor.

Chinese Glove Purse

If you feel like treating yourself to a little present or want to give one of your girl friends



Glove Coin-Purse of suede with a Chinese penny as a dangle Any lucky coin may be used for the dangle.

a gift and do not feel that you can afford to spend much, there is a little novelty which is so inexpensive that you won't have to think twice about whether or not you can spare the money. It is a most unique purse, costing but twenty-five cents. It is made of suede and is so small and soft that you can easily slip it into your glove. It is large enough, however, to hold a quarter. The purse comes in brown suede, and depending from it and attached to a suede strap is a Chinese penny. The strap and dangle act as a safeguard so that the tiny purse is not easily lost.

Care of the Hands

No girl can afford to neglect her hands. If they chap easily, she should rub a good salve or cold cream into them every night before retiring, first washing them with soap and warm water. A very simple remedy for chapped hands is a few drops of carbolic acid in a bottle of glycerin and rose-water, and daily massaging them with cold cream.

Lemon-juice is excellent for softening and bleaching the skin. It is very healing and if used often will keep the hands soft and white. If possible, always use a freshly-cut lemon, rather than lemon-juice which has been bottled, for it is more efficacious. Scissors should not be used on the nails; always file them and care should be used in shaping them. First file them, then soak in warm soapy water, after which push back the cuticle with an orange-wood stick, cutting away all ragged edges. When this is done, apply a little cold cream around the cuticle, wipe off and polish with a buffer and nail-powder. Rose-paste may be used, if desired, to give the nails a nice pinkish appearance.

Home-Made Music-Cabinet

The music-cabinet shown in the above illustration will appeal to the girl who has a piano or organ and wants

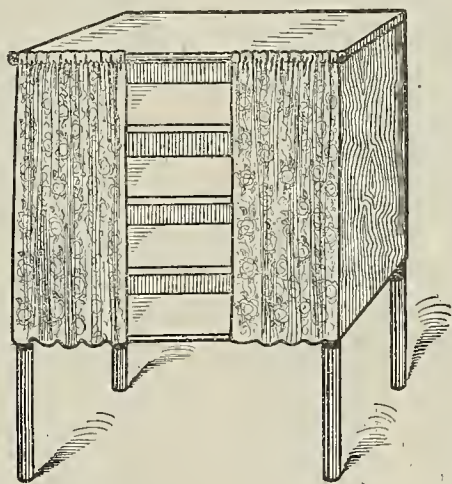

some convenient place to keep her music sheets. It is not always possible to buy a cabinet that is inexpensive and at the same time attractive. But any energetic girl can make this cabinet with a little assistance from her brother. It is made of a box three feet high, fourteen inches wide and ten inches deep. The four legs are made of old broom-sticks and are nailed to each corner before the three shelves are nailed in. The shelves are made of thin pieces of white wood. When the cabinet is complete, it should be given three coats of white paint and one of white enamel. A cretonne or silk curtain hung on a brass rod over the front of the cabinet will add to its attractiveness and also protect the music from dust.

Fob-Set for Mounting

For artistic charm and originality there is nothing like the handcraft jewelry. Some thing which will appeal to the average girl is a watch-fob that can be purchased complete or ready for mounting. One of gray-finished silver with an etched design and with or without a jeweled center is most attractive. Or sometimes the fob is of etched brass or copper. Those made of silver with a jeweled center cost one dollar and fifty cents, while in brass or copper without a jewel, the fob may be purchased for one dollar. These fobs look well mounted on either black moire ribbon or a black crochet band. The girl who has little time for crocheting these silk bands will be glad to know that she can buy a fob already made. We will be glad to tell readers where the purse and fob may be bought if a stamped and self-addressed envelope is inclosed. Address Editor Our Girls at Home, FARM AND FIRESIDE, 11 East 24th Street, New York City.

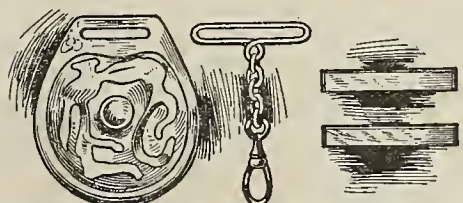

Handcraft Fob-Set for mounting on crochet silk band, ribbon or leather. Made of the new etched silver

Talks on Vocal Culture

Part V.

By Benjamin Schwering

Note—Mr. Schwering will be glad to answer any questions about singing that our readers care to ask, provided a self-addressed and stamped envelope is inclosed. Address Benjamin Schwering, care of FARM AND FIRESIDE, Springfield, Ohio.

Gaining of Temperament

In the preceding lessons you have studied the long vowel sounds, and if you have practised faithfully, they should be mastered by this time. This, really, is one of the most difficult things to learn. It is very important to learn the long vowel sounds carefully, for the short and intermediate sounds are drawn from them. You have now come to a point where you can sing a song, and so one of the important things to be considered first is the gaining of temperament. As you perhaps know, temperament is the ability to give just the right kind of feeling and expression to a song. The best way to get this is to read the words of a song over carefully several times and try to feel the sentiment of the words. A song without feeling or temperament is utterly lifeless and without beauty.

Another thing upon which the beauty of a song considerably depends is proper breath control. In singing, breath must only be taken where there is a pause in the words of a song, and a phrase or group of words that you would speak without a pause must be sung in one breath. To illustrate, I will copy the song "Annie Laurie," putting in a star to indicate the breathing-places.

Maxwilton's braes are bonnie,*
Where early fa's the dew;*
And it's there that Annie Laurie,*
Gied me her promise true,*
Gied me her promise true,*
Which ne'er forgot will be.—*
And for bonnie Annie Laurie,*
I'd lay me down and dee.*

Division of Air Current

In the voice are three tone divisions, known as "chest tones," or "lower range," "mixed tones," or "middle range," and "head tones," or "upper range."

In the lowest tones the greatest part of the air current must be directed against the palate. But no matter how low the tone may be, part of the breath must flow into the nasal cavities.

In the chest tones or middle range the greater part of the air current must flow into the nasal cavities and only a small part be directed against the palate. Under no circumstances, however, must all of the breath be directed into the head, for that makes the tone sound nasal. No set rules can be laid down for the division of breath; this must be acquired by practice and experience. Always bear in mind, the higher you go, the more breath must be directed into the nasal cavities. It is very important that enough breath be directed into the head, for this is what gives the tone life and carrying power and that brilliant bell-like sound which we admire so much in trained singers. If not enough air is directed into the head, the tone sounds hollow and unmusical. This division of the breath is accomplished by force of will-power through the soft palate and the little hanging peak known as the uvula. In order to accustom yourself to its action, look into a mirror and proceed as follows: Open your mouth and take a full breath through the mouth. In doing so you will notice that the soft palate rises up away from the tongue. Then expel the air through the nose and you will see that the soft palate lowers itself toward the back of the tongue, almost pressing against it. In this way the passage through the mouth is shut off and the air goes through the nose.

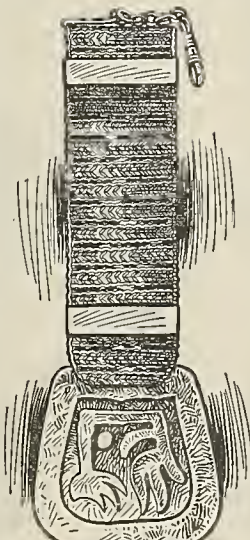

Showing a completed Fob. Mountings on this Fob are of etched brass

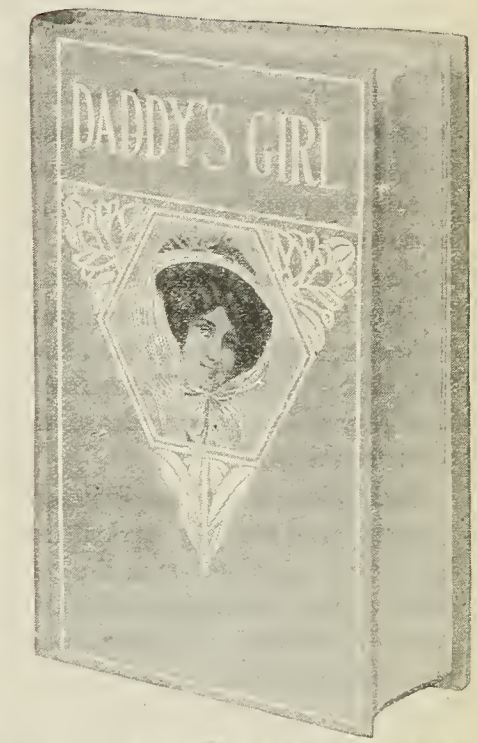

READ THIS LIST

- Adventures of a Brownie.....Mulock
- Alice's Adventures in Wonderland.....
-Carroll
- Andersen's Fairy Tales.....Andersen
- Arabian Nights.....
- Aunt Diana.....Rosa N. Carey
- Averil.....Rosa N. Carey
- Bad Little Hannah.....L. T. Meade
- Bailiff's Maid, The.....E. Marlitt
- Bella's Blue Book.....
- Black Beauty.....Anna Sewall
- Book of Golden Deeds.....Yonge
- Brownie of Sanford.....Carrie L. May
- Bunch of Cherries.....L. T. Meade
- Cuckoo Clock.....Mrs. Molesworth
- Daddy's Girl.....L. T. Meade
- Deb and the Duchess.....L. T. Meade
- Dog of Flanders.....Ouida
- Erl Queen.....N. Von Eschstruth
- Esther.....Rosa N. Carey
- Faith Cartney's Girlhood.....
-Mrs. A. D. T. Whitney
- Four Little Mischiefs.....Mulholland
- Frances Kane's Fortune.....L. T. Meade
- Girls and I.....Mrs. Molesworth
- Girl of the People, A.....L. T. Meade
- Girl in Ten Thousand, A.....L. T. Meade
- Good Luck.....L. T. Meade
- Grimm's Popular Fairy Tales
- Honorable Miss, The.....L. T. Meade
- House That Grew.....Molesworth
- Helen's Babies.....John Habberton
- Jackanapes.....Mrs. Ewing
- Jarl's Daughter.....Mrs. Burnett
- Leona.....Mrs. Molesworth
- Late Miss Hollingsford, The.....Mulholland
- Little Lane Prince.....Miss Mulock
- Little Susie Stories.....Mrs. Prentiss
- Merry Girls of England.....Meade
- N naughty Miss Bunny.....Mulholland
- Next Door House.....Molesworth
- Old, Old Fairy Tales.....Miss Mulock
- Only the Governess.....Rosa N. Carey
- Our Bessie.....Rosa N. Carey
- Out of Fashion.....L. T. Meade
- Pilgrim's Progress.....Bunyan
- Polly, A New Fashioned Girl.....Meade
- Princess of the Moor.....E. Marlitt
- Queechy.....Mrs. Wetherell
- Rab and his Friends.....Brown
- Robin Redbreast.....Molesworth
- Ruth Lovell.....Carrie L. May
- School Favorite.....Mrs. Meade
- Six Little Princesses.....Prentiss
- Six to Sixteen.....Mrs. Ewing
- Stepping Heavenward.....Prentiss
- St. Cuthbert's Tower.....Florence Warden
- Sweet Girl Graduate.....Mrs. Meade
- Sylvia's Burden.....Carrie L. May
- Tales from Shakespeare.....
-Charles and Mary Lamb
- Taming a Tomboy.....Von Rhoden
- Tanglewood Tales.....Hawthorne
- Those Western Girls.....Florence Warden
- Three Bright Girls.....Armstrong
- Through the Looking Glass.....Carroll
- Rime of Roses.....L. T. Meade
- "Us".....Molesworth
- Very Odd Girl, A.....Armstrong

These books, as you will see from the titles, are standard works peculiarly suited to the girl. The printing is clear, on good paper, and the cloth bindings are substantial and attractive.

To obtain your choice of any one of these fine books for girls, send us only three 8-month trial subscriptions to FARM AND FIRESIDE, at 25 cents each. We will then send you, postpaid, any book from the above list that you may select. Send all orders to

FARM AND FIRESIDE, Springfield, Ohio

Farm and Fireside's Offer to You

The Editors Ask Every Subscriber to Read This Notice

FARM AND FIRESIDE wants to have more of your neighbors among its readers. You can help us to accomplish this, and we will pay you handsomely for your help. Thousands of our friends have written to us saying that FARM AND FIRESIDE is the best farm journal published at any price. If you, also, feel that FARM AND FIRESIDE is a mighty good paper, please tell your friends so.

Tell them about the Farmers' Lobby, and the big agricultural features. Tell them that the best farm writers contribute to FARM AND FIRESIDE. Tell them about the stories and pictures and household departments and patterns.

As an inducement to your friends to subscribe now you can offer to any of your neighbors an 8-month trial subscription to FARM AND FIRESIDE for only 25 cents. We will appreciate it if you will ask at least two friends to become readers of FARM AND FIRESIDE.

Our Offer to You

Get two friends each to give you 25 cents for an 8-month trial subscription to FARM AND FIRESIDE. Send us the 50 cents, and in return for the favor we will send you FARM AND FIRESIDE, for eight months, without cost, after your present subscription expires. If you are not now a subscriber, your own subscription will be entered for eight months, without cost. In addition, the editors of FARM AND FIRESIDE will mail you a handsome present.

The present from the editors will be something unique, something that will please every member of your family. It will be sent to you absolutely without cost, in addition to the 8-month subscription to FARM AND FIRESIDE, in return for your sending us 50 cents for two 8-month trial subscriptions.

This offer is good for thirty days only. You should act at once. Write the names and addresses of your two friends and your own name and address on the coupon below and send to FARM AND FIRESIDE with 50 cents. You will receive FARM AND FIRESIDE for eight months, without cost, and will also receive the gift from the publishers.

FARM AND FIRESIDE
Springfield, Ohio

Send This Order-Blank

GIFT COUPON

This coupon entitles any reader sending two trial 8-month subscriptions, at 25 cents each, to an 8-month subscription extension as explained above, in addition to

A Beautiful Gift

from the editors of FARM AND FIRESIDE.

Your Name _____

Address _____

Write below names of two trial subscribers:

Name _____

Address _____

Name _____

Address _____

If you do not wish to cut this page, write your order on a piece of paper.

Good-Style Clothes From Madison Square Patterns

THE temptation to have twice as many dresses this summer as you need is really a very big sort of a temptation. The new fabrics are so alluring that each one seems just suited to a certain type of gown. For instance, there is a granite linen, which resembles a basket weave and has a sheen through it, which is just the smartest sort of material for a one-piece dress or a skirt-and-coat suit. Then there are shantung linens which are serviceable substitutes for the silk by that name, and as for our old friends, the ginghams and zephyrs, they are the smartest things out, and the silk and cotton mixtures have never been so beautiful as they are this summer. There are really a dozen different materials for each style of gown and it certainly is not difficult to find several equally-appropriate materials for the dress shown in pattern No. 1512. With its becoming long lines and fashionable double sleeves, it makes a very smart gown for church or summer afternoons. The undersleeves are separate and the gown can be made either with them or with just the fancy three-quarter-length sleeve. Of course, the most fashionable mode is the double one, secured by using the oversleeve and the undersleeve.

The well-dressed young girl is the girl who dresses as though she were a young girl. Clothes which her mother might wear or gowns suitable for her older sister are not only inappropriate for her, but, let her remember, are not fashionable for her, either. Simplicity should always be the style key-note of the young girl's dress and a dress which is truly that is shown in the design of pattern No. 1498 and No. 1499. Leaving out the small youngster, there is no one to whom this Russian blouse style is so becoming as the young girl. The one illustrated on this page is such a simple little frock that any young girl can easily make it herself. The blouse is loose and belted in at the waistline. It has a square yoke and the bishop sleeves are finished with a cuff. The skirt is a plain five-gored model with inverted plaits at the back. Made of plaid gingham, with plain dark-toned gingham for trimming-bands, this makes a very stylish frock for summer days. Or, another pretty idea is to have the dress of plain material with trimming-bands of the same color in a darker tone.

IT's a blessing to most of us that the fashions to-day offer more leeway than they ever did before. If we have good taste, we can really dress almost as we please and yet have the satisfaction that our clothes are in the mode. For instance, both short sleeves and long sleeves are being worn; waists are made with high necks and cut with the low, round necks. Both are fashionable. The normal waistline should be emphasized, however, as the newest Paris dresses are all made in this way. The high waist or the exaggeratedly long waist are no longer in vogue. It is surely a happy fact to hear that the more simple the gown, the more effective and fashionable it will be this season.

FASHION certainly is kind these days to the woman who must economize and make last year's dresses do duty this year. Several years ago it was almost impossible to make a second-season gown look like new. Now, however, this is not only possible, but very smart, up-to-date costumes can be secured by combining two old dresses. For instance, you may have a black and white striped cotton voile which you wore all last summer. It is soiled and ragged around the bottom of the skirt, the tight sleeves are worn through at the elbows, and around the neck it is shabby. For a gown of this sort there are a number of surprising possibilities.

Then you may have a black cloth gown which you have made over and over again. Now if you are clever with your needle and are informed of the new styles, you will quickly see that you can take these two old frocks and make them into what will seem an entirely new gown. You will take the striped voile and cut it off a little below the knees. The skirt of the black dress you will cut up and form into a deep band which you will put on the bottom of the black and white striped voile upper. You will cut the voile waist out square at the neck, cut the sleeves off at the elbow and then change the whole appearance of the waist by finishing the square neck with a bias fold made from bits of the old black skirt. You will make it about an inch wide and will machine stitch it with black silk. Then you will make a two or three inch black cloth cuff, which will fit snugly around your arm, just below the elbow. To make the dress high neck and with long sleeves, you will have the yoke and undersleeves of all-over embroidery or fine lawn. You will make a stitched two-inch belt of the black cloth. And there you are. A new gown to everybody but yourself and not an extra penny spent.

Then, too, you may have a lingerie waist, a silk waist or one of net which is a little worn or soiled. At first you will think you can do nothing with it. Then you will remember that you can make it not only go through another season, but very stylish by having one of the fashionable overblouses so much the vogue.

Although the most correct style is to have your waist match the skirt with which it is worn, you can easily secure this effect with a white lingerie waist, by having the overblouse the color of your skirt. First you will carefully mend and clean the bad places of your old waist, and then you will invest in two or three yards of chiffon or cotton voile and make one of these new overblouses, with the waist and sleeves cut in one. You will edge the collarless neck and sleeves with silk folds or lace.



No. 1512—Princesse With Double Sleeves

Pattern cut for 34, 36, 38 and 40 inch bust measures. Quantity of material required for medium size, or 36 inch bust, ten yards of twenty-four-inch material, or seven yards of thirty-six-inch material, with one and three fourths yards of contrasting material twenty-two-inches wide for undersleeves and yoke.

This is an especially good pattern to own, for it can be developed in any number of materials and yet seem quite the appropriate design for each one. For instance, an every-day dress could be cut from it and, made of gingham or chambray, be very practical, or, if you are looking for a dressy gown, you could make one of silk or poplin, which would be extremely smart.



No. 1498—Misses' Russian Blouse

Pattern cut for 12, 14 and 16 year sizes

No. 1499—Misses' Five-Gored Skirt

Pattern cut for 12, 14 and 16 year sizes

Madison Square Patterns

FOR every design illustrated on this page, as well as every fashion illustration in our big spring catalogue, we will furnish a pattern for ten cents. It is an easy-to-use pattern and the gown you make from it is invariably a success, for the pattern is perfect in its every detail. Here is our latest liberal offer: We will give one Madison Square pattern if you send us only one new subscription to FARM AND FIRESIDE for eight months at the special price of twenty-five cents. The subscription must be for some one not now a subscriber to FARM AND FIRESIDE. This offer holds good up to May 10th. Send orders to the Pattern Department, FARM AND FIRESIDE, 11 East 24th Street, New York City. Follow these directions when ordering: For ladies' waists, give bust measure in inches; for skirts, give waist measure in inches; for misses' and children, give age. Don't fail to mention the number of the pattern you desire.

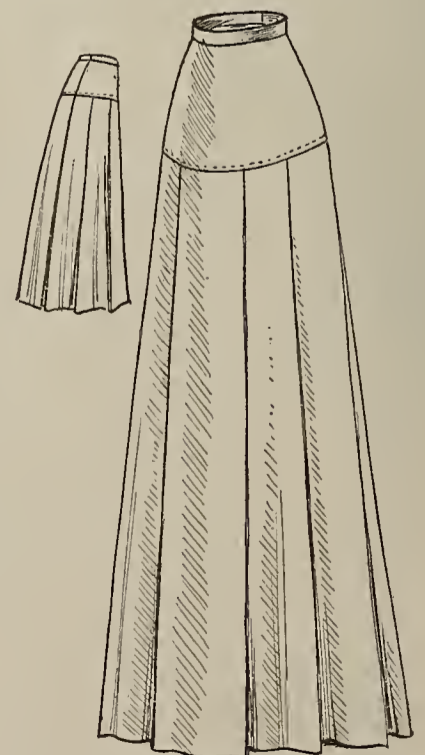

No. 1524—Plaited Skirt With Yoke

Pattern cut for 24, 26, 28 and 30 inch waist measures. Quantity of material required for medium size, or 26 inch waist, six yards of thirty-six-inch material, or four and one half yards of forty-four-inch material

Miss Gould's Dressmaking Lesson



This low-necked short-sleeved shirt-waist can be made from the same pattern as the tailored waist. It is cut in the same sizes, from 34 to 44 inch bust measures inclusive. Quantity of material required for the low-neck waist, with the collar-and-cuff set, in medium size, four and one half yards of twenty-four-inch material, or two and five eighths yards of thirty-six-inch material.

IF YOU need to keep your eye on the pennies and plan to be our own dressmaker, be sure and use the Madison Square patterns. They are the most economical patterns you can find and the chief reason is because of their adaptable qualities. You can buy a pattern and pay but ten cents for it and often from this pattern make two entirely different garments, such as two waists or two skirts. This dressmaking lesson tells about one of these adaptable patterns. You really get very much for your money, for from the one pattern you can make not only the smart-looking tailored shirt-waist illustrated in the center of the page, but the more dressy waist shown in the upper left-hand corner as well as the very latest design for a collar-and-cuff set, which you can wear, not only with the low-neck waist here pictured, but with many of your dresses which perhaps need a new touch to make them presentable this year.

The envelope for pattern No. 1515, Shirt-Waist in Two Styles, contains fourteen pieces. Each piece is lettered and referred to by letter so it would be impossible to confuse the pieces. There are many small pieces in this pattern that look alike, and without this method of lettering the amateur dressmaker might make a mistake.

The front of the shirt-waist is lettered V, the back T, the belt X, the shirt sleeve K, the cuff J, the neckband I, the collar L, the collarband F, the puff sleeve M, the armband E, the flaring cuff H, the fancy collar W, the tab N and the jabot A.

Before cutting, decide which style of shirt-waist you wish to make and select the pieces belonging to that particular style. The front, back, belt, neckband, collar, collarband, shirt sleeve and cuff are for the tailored shirt-waist.

For the low-neck waist use front, back, belt, puff sleeve, armband, flaring cuff, fancy collar, tab and jabot.

Smooth the wrinkles from the tissue before placing the pattern pieces on the material. Lay the edges marked by triple crosses (XXX) on a lengthwise fold of the material. Place the other parts of the pattern with the line of large round perforations in each lengthwise of the goods.

Be sure to mark all perforations and cut out all the notches before removing the pattern pieces from the material.

To Make the Tailored Shirt-Waist

Form the plaits in each front by bringing the corresponding lines of triangle perforations together. Stitch on these lines and press flat. Now join the pieces by corresponding notches.

Gather at the waistline between the double square perforations. Arrange the belt on the under side of the waist along the lines of square perforations which indicate the waistline. Match the centers of waist and belt, back and front, and bring the large round perforation in the belt to the under-arm seams. Distribute the fullness at the waist evenly and pin securely before basting the belt to position.

Try on the shirt-waist and see if the gathers are arranged in a becoming manner. Sometimes the fullness will look better if it is drawn closer to the front, while on other figures it looks well to have the gathers extend all the way back to the under-arm seam. After you have arranged the fullness at the waist in a becoming manner, stitch to position. Two rows of stitching, one at the upper edge of the belt and one at the lower edge, will hold the gathers in place if the fabric is heavy. Turn hems on the shirt-waist fronts and belt by notches. Join the neckband to neck by notch. Now lap the fronts, matching the center lines of large round perforations, and button through the hem.

Work the buttonholes through the hem on the right front directly on the line of large round perforations and sew the buttons on the left front on the corresponding line.

The hems may be stitched in one fourth of an inch from the edge and also one and one fourth inches in from the edge to hold the loose end in place

matching the center lines of large round perforations, and fasten to the neckband with collar-buttons.

To Make the Low-Neck Waist

First cut out the fronts V shape at the neck by line of small round perforations. Then make the body portion of the shirt-waist and adjust the belt as directed for the tailor-made waist. Face the neck edge of the waist with a narrow straight strip of the material, using a selvage edge if possible. Gather the puff sleeve at upper and lower edges between double crosses. Join the armband to the lower edge of the sleeve according to notches. Distribute the gathers in the lower part of the sleeve evenly and pin to the armband before basting. Join the flaring cuff to the lower edge of the armband by notches. Hold the sleeve toward you when arranging it in the arms-eye. Place the seam in the sleeve at the notch in front of shirt-waist and bring the notch in the top of sleeve to the shoulder. Pin first at these two points and then continue as directed for the shirt sleeve.

Three-eighths-of-an-inch seam is allowed on all edges of this pattern, except at the shoulder and under-arm seams, where one inch is allowed, designated by lines of small round perforations.

The Collar-and-Cuff Set

The patterns for the collar-and-cuff set may be used separately, and these little accessories can be worn with different shirt-waists.

The neck edge of the collar should be finished with a straight half-inch band of material and arranged around the neck of the low-neck waist.

Form the plaits in the jabot by creasing on the lines of triangle perforations and baste in one half inch from the edge of each crease. Press the plaits flat, then remove the bastings.

Now lap the plaits at the top until the jabot is just one inch wide and join the tab to the upper edge of the jabot. Stitch tab and jabot together at the top, and then pin to the waist at the point of the collar.

Almost every fashionable well-dressed girl is having some of her waists cut out at the neck. The most attractive way to finish these low-cut blouses with elbow sleeves is to have the low wide collar, the jabot and the turn-back cuffs embroidered in some bright tone, such as royal blue, Indian yellow or lavender. If one does not care for embroidery, lace inserts with a lace edging would be very attractive. The pattern for the collar set does not come stamped for embroidering, so it will be very easy to develop the different pieces in the most becoming design.

Miss Gould will be glad to answer any questions pertaining to home dressmaking which may perplex the readers of Farm and Fireside. She will send by return mail a personal letter to the writer if a stamped and self-addressed envelope is inclosed. Direct all letters to Miss Gould's Dressmaking Department, care of Farm and Fireside, 11 East 24th Street, New York City

No. 1515—Shirt-Waist in Two Styles, Including Collar-and-Cuff Set

Pattern cut for 34, 36, 38, 40, 42 and 44 inch bust measures. Quantity of material required for this tailored shirt-waist in medium size, or 38 inch bust, three and five eighths yards of twenty-four-inch material, or two and one fourth yards of thirty-six-inch material. The price of this pattern is ten cents. Order from the Pattern Department, Farm and Fireside, 11 East 24th Street, New York City

on the under side, or only one row of stitching may be used in center along line of large round perforations.

Slash the shirt sleeve at the back on the line of small round perforations and face the edges of the opening. Gather the sleeve at upper and lower edges between double crosses. Make the cuff for this shirt sleeve double. Stitch the lower and side edges, but leave the cuff open at the top. Then slip the lower edge of the sleeve in between the two thicknesses of the cuff. Join the under side of the cuff to the sleeve as notched. Then baste the upper side of the cuff over the edge of the sleeve and stitch securely. The cuff opens at the back.

Hold the sleeve toward you when arranging it in the arms-eye. Bring the seam in the sleeve to the notch in the front of the shirt-waist and bring the notch at the top of the sleeve to the shoulder seam. Pin first at these two points. Then pin the plain part of the sleeve smoothly in the arms-eye. Draw up the gathers at the top of the sleeve to fit the remaining space. Distribute the fullness evenly and pin carefully before attempting to baste the sleeve to position.

Join the collar to the collarband as notched. Work buttonholes in the neckband and collarband at center back and front. Arrange the collarband around the neck. Lap the ends in front,

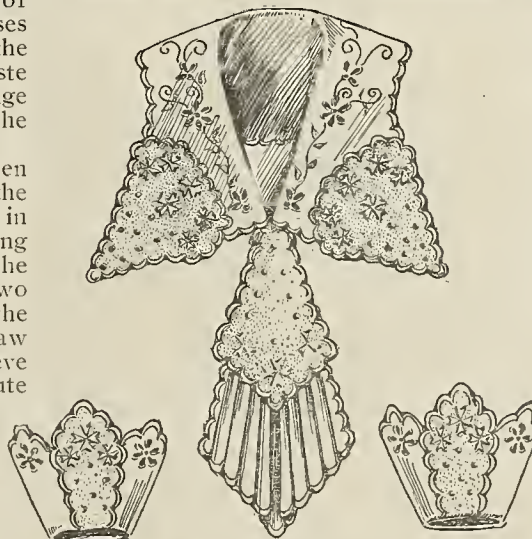

The jabot collar and cuff set which is included with pattern No. 1515

POSTUM FOR MOTHERS

The Drink that Nourishes and Supplies Food for Mother and Child

"My husband has been unable to drink coffee for several years, so we were very glad to give Postum a trial and when we understood that long boiling would bring out the delicious flavour, we have been highly pleased with it.

"It is one of the finest things for nursing mothers that I have ever seen. It keeps up the mother's strength and increases the supply of nourishment for the child if partaken of freely. I drank it between meals instead of water and found it most beneficial.

"Our five-year-old boy has been very delicate since birth and has developed slowly. He was white and bloodless. I began to give him Postum freely and you would be surprised at the change. When any person remarks about the great improvement, we never fail to tell them that we attribute his gain in strength and general health, to the free use of Postum and this has led many friends to use it for themselves and children.

"I have always cautioned friends to whom I have spoken about Postum, to follow directions in making it, for unless it is boiled fifteen or twenty minutes, it is quite tasteless. On the other hand, when properly made, it is very delicious. I want to thank you for the benefits we have derived from the use of your Postum."

Read "The Road to Wellville," found in pkgs. "There's a Reason."

Ever read the above letter? A new one appears from time to time. They are genuine, true, and full of human interest.

A FLOOD OF LIGHT FROM KEROSENE, Coal Oil!
Burning common kerosene the ALADDIN MANTLE LAMP generates gas that gives a light more brilliant than city gas, gasoline or electricity. Simple, odorless, clean, safe and durable. **AGENTS MAKE BIG MONEY** is revolutionizing lighting everywhere. Needed in every home. Every lamp guaranteed. Sells itself. Our Sunbeam Burners fit other lamps. Ask our nearest office how you can get a lamp free or apply for Agency Proposition. **THE MANTLE LAMP CO. of America, Desk 314**
Chicago, Portland, Ore.; Waterbury, Conn.; Winnipeg, Montreal, Canada.

Get Your **Rose-Bushes** At Once To Bloom This Summer

Your Last Chance to get Rose-Bushes without cost that will bloom this summer

Five Favorite Roses

(Order as No. 101)

1. Climbing Meteor—The brightest colored of all roses and a persistent bloomer.
2. Mrs. Ben R. Cant—Deep red and one of the hardiest and finest varieties.
3. Mlle. Franzisca Kruger—Deep yellow—unique and distinct from all others.
4. White Maman Cochet—Snow white, tinged with the faintest suggestion of blush.
5. Etoile de Lyon—One of the hardiest and most beautiful yellow tea roses.

This Rose Collection

was grown especially for FARM AND FIRESIDE by one of the greatest nurseries in America, and FARM AND FIRESIDE now offers it without cost to its readers.

Guarantee

All plants will be large, healthy and well rooted, and will bloom the coming season. We guarantee them to be exactly as described, to arrive in perfect condition, and to give entire satisfaction or your money cheerfully refunded.

How to Get Them

Send us only TWO 8-month subscriptions to FARM AND FIRESIDE at the special price of 25 cents each, and we will send you without cost, this collection of fine Rose-Bushes; or we will send it for one year's subscription to FARM AND FIRESIDE.

FARM AND FIRESIDE, one year } 50c
Rose Collection, without cost }

The subscriptions may be new or renewal. One of the subscriptions may be your own. Send all orders to

FARM & FIRESIDE, Springfield, O.



Haste and Waste

Stop and think for a moment the next time you are about to buy soda crackers.

Instead of hastily buying soda crackers that go to waste because broken, soiled or soggy, buy

Uneda Biscuit

in separate five-cent packages. Soda crackers in large packages soon become broken, stale and unpalatable. On the other hand, Uneda Biscuit in handy, moisture proof packages are *always* fresh, clean, crisp and whole—*not one wasted*.

(Never Sold in Bulk)

NATIONAL BISCUIT COMPANY



A Few of the Post-Cards

Decoration Day Post-Cards

These Decoration Day Post-Cards, fifteen in all, are the most up-to-date and beautiful you ever saw. We show only a few to give you some idea of what they are like. You will be delighted with their heart-inspiring beauty and their solid worth. You can get them without cost.

Don't Fail to Get Them

These are such interesting post-cards. Everything connected with Decoration Day is shown in the most exquisite colors and gold. There are children in white dresses, with garlands for decorating the veterans' graves; white-haired veterans in their blue uniforms (some are gray, too); the G. A. R.

emblem—the five-pointed star with the American flag; the emblems of the Sons of Veterans and the Daughters of the Regiment; the knapsacks, canteens and campaign hats. In fact they are simply wonderful, heart-inspiring. They are sensible and fine. You will enjoy sending them to friends.

Get Them Without Cost

We will send you these fifteen Decoration Day Post-Cards without cost (every one different), if you will send us one new 8-month subscription to FARM AND FIRESIDE at 25 cents. The subscription must be for some one who does not now take FARM AND FIRESIDE.

FARM AND FIRESIDE guarantees that you will be delighted with these cards. Send the subscription today and we will send you the fifteen Decoration Day Post-Cards by return mail. Send your order to

FARM AND FIRESIDE

Springfield, Ohio

The Beauty of the Helping Hand

By Edgar L. Vincent

A BARE rock is not the most likely place in the world to look for water. And yet, one day in a time when the earth was dry and the farm creatures were panting for a cooling drink to slake their thirst, we climbed the side of the hill in the pasture and at a place where a damp spot appeared right on the surface of a flat rock we struck the pick down deep into the heart of the ground. In a little while a tiny stream trickled down to moisten the earth at our feet, and hope sprang higher when the rivulet grew into a bubbling fountain strong enough and lasting enough to furnish water for the thirsty cattle through all the days.

Help came out of the rock.

The sturdy men of old who built up the language of the Anglo-Saxon race knew no better way of making words than to put into them something of life, thought or action. And when they wished to give expression to the longing of their hearts to tide over a hard place, not simply by lifting the one in trouble in their arms, but by giving him power to do the trying thing himself, they gave us the word "help." Short, strong, like the stout arms of the men who first used it, and yet tender as the heart of the mothers who rocked the children of the north in their bosoms.

What is our idea of help to-day? Is it not to stoop down and carry some one over hard places in life? Yes, that is in the word, but help, real help, is more than that. To help another in the highest and best sense is to put the power into his arm to strike for himself and strike successfully.

I know a father and mother who have done grand things. Beginning away down at the foot of the ladder on the farm, they struggled on through years of hardship, sufferings and privations until the farm was paid for. No one will ever know their names outside the little circle of the home acquaintances, and yet they have done a finer work than the man who wins a mighty fortune and lets that burn his heart out.

But that father and mother are trying to shield their boys and girls from the hard things they have known. They make life so easy! They cannot bear to have the dear ones know what it is to do without anything they want if it be within their power to get it for them. All the good clothes, all the beautiful home surroundings, all the jewels which wealth can command, these children have, and no wish of their hearts goes unsatisfied. Is this help of the best kind?

The spring up on the hillside does not do everything for the thirsty creatures that need its limpid waters. Every day the long line of cattle must climb the steep pasture path. They must wait at the fountain for each other. They must

stoop and take for themselves the draft that will quench their thirst. It was love that opened the stream which flows out of the rock, but it was a love that leaves something undone for those who would enjoy its benefits.

Stop a moment, dear young folks, and think of this.

Help that leaves you weak and nerveless is not really help. What you want, what you must have, if you would take the place in life you ought to take, is help that gives you power to act for yourselves. The strongest manhood comes from winning the prize for one's own self. You would not be satisfied, would you, to have dropped into your hands prizes you had not earned? For the moment there might be something of pride in hearing your companions say, "I congratulate you!" But the light of pride will soon grow dim and fade away. Better by far know the joy of honestly earning the thing you seek. When your own right hand brings the reward, the heart has a right to bound with happiness. The treasure we dig from the mine ourselves is the richest of all.

Climb the hill, then, and drink at the spring that some one has dug for you.

All the world has been making ready for you. You are in a place where you may reap the golden grain which has been sown all through the ages gone by. Men have worked hard to place within your reach all you will ever need to make you happy and successful. They have worked and sacrificed and dreamed and wept that you may live a better life than any who have ever dwelt on this old earth. But that does not make it right that you should just sit down and say, "I am going to sit down here and wait for all these things to come to me." If you do, you will never know the joy and the beauty of the helping hand.

For it is the one who helps that gets the most good. It may be just to say some kindly word. Perhaps to speak the word which shall comfort some troubled heart may be all you can do. Never mind how poor the thing you can do may seem to you, do it, and do it with a pure heart and a strong purpose. It will make you happier than you ever were before in all your life. It will give you strength to do something better by and by.

Don't let any one rob you of the joy of helping yourself. If you are beginning to feel the paralysis of selfish waiting creeping over you, arouse yourself now and strike hard blows for yourself, and keep on striking as if for dear life, until you have felt the fire of independence thrilling your heart and spurring you on to grander things than you have ever done before.

Then you will know the beauty of the helping hand.

Good Thoughts and Good Verses

My Creed

I would be true, for there are those who trust me; I would be pure, for there are those who care; I would be strong, for there is much to suffer; I would be brave, for there is much to dare. I would be friends to all—the foe, the friendless; I would be giving, and forget the gift; I would be humble, for I know my weakness; I would look up, and laugh, and love, and lift.

HOWARD ARNOLD WALTERS.

Be not afraid to pray—to pray is right.

Pray, if thou canst, with hope, but ever pray.

Though hope be weak or sick with long delay,

Pray in the darkness if there be no light.

HARTLEY COLERIDGE: Prayers.

Now is the time! ah, friend, no longer wait

To scatter loving smiles and words of cheer,

To those around whose lives may be so drear:

They may not need you in the coming year—

Now is the time!

When wealth is lost, nothing is lost; When health is lost, something is lost; When character is lost, all is lost.

—Motto over the walls of a school in Germany.

The supreme joy of life is the joy of right living.

Life consists of many little beginnings which culminate in one great ending.

Some farmers allow a little thing like a line fence to come between them and their neighbor. A line fence should divide farms, not friends.

When the farmer goes to worship, he should leave his farm at home. It will be there when he gets back.

If you'll sing a song as you go along, In the face of the real or fancied wrong,

In spite of the doubt if you'll fight it out,

And show a heart that is brave and stout;

If you laugh at the jeer and refuse the tears,

You'll force the ever-reluctant cheers

That the world denies when a coward cries,

To give to the man who bravely tries. And you'll win success with a little song

If you'll sing the song as you go along!

ROBERT McCLAIN FIELDS.

A trouble either can be remedied or it cannot. If it can be, then set about it; if it cannot be, dismiss it from consciousness or bear it so bravely that it may become transfigured into a blessing.

LILIAN WHITING.

MISCHIEF MAKER A Surprise in Brooklyn

An adult's food that can save a baby proves itself to be nourishing and easily digested and good for big and little folks. A Brooklyn man says:

"When baby was about eleven months old he began to grow thin and pale. This was, at first, attributed to the heat and the fact that his teeth were coming, but, in reality, the poor little thing was starving, his mother's milk not being sufficient nourishment.

"One day after he had cried bitterly for an hour, I suggested that my wife try him on Grape-Nuts. She soaked two teaspoonfuls in a saucer with a little sugar and warm milk. This baby ate so ravenously that she fixed a second which he likewise finished.

"It was not many days before he forgot all about being nursed, and has since lived almost exclusively on Grape-Nuts. Today the boy is strong and robust, and as cute a mischief-maker as a thirteen months old baby is expected to be.

"We have put before him other foods, but he will have none of them, evidently preferring to stick to that which did him so much good—his old friend Grape-Nuts.

"Use this letter any way you wish, for my wife and I can never praise Grape-Nuts enough after the brightness it has brought to our household."

Grape-Nuts is not made for a baby food, but experience with thousands of babies shows it to be among the best, if not entirely the best in use. Being a scientific preparation, of Nature's grains, it is equally effective as a body and brain builder for grown-ups.

Read the little book, "The Road to Wellville," in pkgs. "There's a Reason."

Ever read the above letter? A new one appears from time to time. They are genuine, true, and full of human interest.

The Wrong Miss Jane [CONTINUED FROM PAGE 24]

whose mouth twitched nervously. She was about to speak, but Cabeen talked on rapidly: "I realize how foolish, how insane, all this must sound to you, how wild, how unreasonable. But it is true—what I have told you—and I could not let it go unsaid. At college I played foot-ball, and while my team-mates were playing with their hearts up in the grand-stand where their sweethearts sat, I was always playing for this girl I'd dreamed of all my life. She has been very real to me—so real that when I saw you in the station, I knew at once that you were she. Please don't think ill of me for telling you this. I wouldn't have, had I been able to restrain myself. I don't suppose you would ever care anything for me. I have no doubt that you will never even look at me again after my conduct to-night. Yet I will always have the consciousness of having actually seen and talked to you and listened to your voice."

Then, hardly knowing what he did, he extended his hand and touched hers, but so lightly that she did not seem to know. And then he withdrew it quickly, grateful and almost surprised that the vision opposite was actually of flesh and blood. And suddenly, before the girl could reduce to words the strange emotions which swam in a bewildering stream through her soul, an interloper appeared.

"Why, uncle!" she exclaimed, perceiving a distinguished-looking middle-aged gentleman who had paused at the table. "You in town, my dear!" he exclaimed. "Why on earth didn't you let us know you were going to be in New York?"

"Uncle," added the girl without waiting to answer the other's question, "I want you to meet Mr.—Cabeen. Mr. Cabeen met me at the station," she added. "I intended to catch the twelve o'clock train for home—"

"You sha'n't do any such thing," interrupted the gentleman. "You're coming along with me to visit the folks. The machine's waiting. And Mr. Cabeen must permit us to drop him at his door on our way."

"I'm afraid I should put you to unnecessary bother," replied the youth.

"It will be an honor, I assure you," rejoined the other. "My niece and I have watched you and your team-mates ram defeat into the ranks of Princeton and Harvard more than once."

Later, when the three entered the ton-

neau of the magnificent six-cylinder motor car and Cabeen sank into soft cushions beside the magic creature whom a singular fate had brought at last into his life, he could hardly believe he was not dreaming. All too soon the car stood at the door of the club on Forty-Fourth Street. Again he felt the touch of the girl's dainty hand as he bade her and her kinsman good-night. The youth stood watching the car until it whipped around the corner and vanished from his sight.

Two important letters were in Billy's mail next morning. One was from Miranda. The other was in a square envelope, daintily addressed in a strange hand-writing.

DEAR MR. CABEEN:—There is something I must write and tell you before I go to sleep, something I dared not tell you last night. I saw you often while you were at Yale, wanted to meet you, never did. At one of your fraternity dances I was to have danced with you, but you were ill and did not come. Somehow, I have always felt that we should meet after all. And last night at the station when you spoke to me, though I knew you thought I was some one else, I was weak and selfish enough to let you. Not until we were at supper did I have the courage to tell you of your mistake. Can you ever forgive me? I wonder now whether you actually said what I thought you did as we sat at the table together. It seems that I must have been dreaming. If I did not only dream and you really care to see me again, please prove it by discovering my identity and coming to see me. I shall be at my uncle's home visiting one week.

THE WRONG MISS JANE.

Thrice the youth's eyes devoured the missive, while in his heart the fires of happiness burned like a lambent furnace. It is not often in this work-a-day world that the dreams of youth, the more extravagant dreams, ever come true. Seldom had Billy dared hope that his fragile gauze-made dream would ever attract the conjurer's wand and gain the strengthening fibers of reality!

Then he opened Miranda's letter. It was brief, and held also its surprise:

DEAR BILLY:—Can you ever forgive me for writing you that letter yesterday? It was all a practical joke. I am dying to know what happened at the Grand Central Station. Please don't be angry. I'll never do such a terrible thing again. I did it to get even with you for that trick you played on me last Christmas. MIRANDA.

Billy grinned. Then he wrote and sent the following telegram to Miranda: "If you had not, I could never have forgiven you. Billy."

Grandmother-Hunting [CONTINUED FROM PAGE 22]

"Has you got any little boys all your own?"

And now Paul himself was ready to weep. The last question hadn't helped any and she was really going to cry.

"I wish my faver or Mrs. McMurphy would come!"

This remark had a most astonishing effect. His hostess hurriedly dried her eyes and spoke.

"I ought to be ashamed of myself. I've been so nervous all day."

Having, from past experience, a vague idea of the word "ashamed," Paul thought she was scolding herself; so he sympathetically raised one chubby hand and gently patted her cheek. This made the dear lady laugh and soon she was singing a gay little song about a froggy who lived over in a meadow.

Rather disappointed at the result to secure this wonderful lady for a grandmother and being tired out with his strenuous day, Paul soon fell asleep, and as the woman placed him on the couch she sighed and said softly, "Is it only the old longing that has made me think you look like my own baby? Oh, I've prayed all day that my boy may come to-night."

"Mr. Stanforth, ma'am," said the maid at the door and, turning, she knew her petition had been answered.

"Mother!"

"Oh, my boy, can it be you after all these years of waiting?"

While trying, with their arms about each other, to explain away the past separation, Stanforth caught sight of the brown curls of the sleeping boy.

"Why, who is this baby?"

Without waiting for her answer, he walked to the couch and in his surprise stood for a moment speechless before exclaiming: "Mother, this is my own boy! Why, how did it happen?"

She told him while in the gladness of reunited hearts they looked upon the slumbering baby so dear to both.

Disturbed by the voices, Paul stirred in his sleep and was swept up in his father's arms.

Pressing a kiss on the rosy mouth, Stanforth said joyfully, "Wake up, you young scamp! We've found you the dearest grandmother in all this big world!"

The **BAKER'S** Genuine **Breakfast Cocoa**



with the *delicious* natural flavor and the rich red-brown color characteristic of this high grade cocoa is made only by

Registered U. S. Pat. Office
Walter Baker & Co. Ltd.
Established 1780 DORCHESTER, MASS.

Paper 3 rooms at the cost of one



Put new life into the looks of your rooms with stylish and attractive wall-paper. Buy direct from us at manufacturer's price. Then hang it yourself (we tell you exactly how) and you save half the usual cost of paper, and all the cost of labor. Total saved—two-thirds. Free sample book of latest patterns, and full instructions how to hang the paper. Write for it to-day.
Penn Wall-Paper Mills
Dept. 6, Philadelphia

Battleship Post-Cards

20 Views of Our Biggest Fighters in Colors

We will send you the complete set of 20 Battleship Post-Cards if you will send us 10 cents each for two three-month trial sub' tions to FARM AND FIRESIDE. The two trial subscriptions must be new subscriptions. Send the 20 cents for the two subscriptions in coin or stamps.

FARM AND FIRESIDE
Springfield, Ohio

WATCH RING & GIVEN
FOR SELLING POST CARDS



We positively give a STEM WIND, STEM SET, BEAUTIFULLY ENGRAVED, PLATED WATCH, equal in appearance to Solid Gold Watch, American made, guaranteed, and a beautiful Ring set with an Im. Diamond, for selling only 20 pkgs of beautiful high grade art post-cards at 10c a package. Order 20 packages, and when sold send us \$2 and we will positively send you the Watch, Ring and Chain. Wells Mfg. Co., Dept. 476 Chicago

MEMORIALS & MONUMENTS
FOR CEMETERIES SCHOOLS & PARKS

LARGE VARIETY OF DESIGNS FOR EVERY PURPOSE. DELIVERED ANYWHERE. SEND FOR CATALOGS. STATE REQUIREMENTS. AGENTS WANTED.

MONUMENTAL BRONZE CO.
347 HOWARD AVE., BRIDGEPORT CONN.

EARN Watch, Ring AND CHAIN
FOR SELLING POST CARDS



We positively give both a Famous Alton Watch, Stem Wind, handsomely designed case, American movement, factory tested, guaranteed five years, also a nice Ring set with a Congo Gem, sparkling and fiery, for selling 20 packages beautiful high grade Art Post Cards at 10c per package. Order 20 packages, when sold send \$2 and we will positively send you the watch, ring & chain. Satisfaction guaranteed. ALTON WATCH CO., Dept. 481, CHICAGO

PATENTS Secured and SOLD
Five practical, useful booklets concerning the obtaining, financing and selling of patents. Sent Free. Write Today. Advice and searches Free. Dept. T, PATENT DEVELOPMENT CORPORATION, Washington, D. C.

LAWN FENCE



Many designs. Cheap as wood. 32 page Catalogue free. Special Prices to Churches and Cemeteries. Coiled Spring Fence Co. Box 414 Winchester, Ind.

ORNAMENTAL FENCE



25 DESIGNS, ALL STEEL Handsome, cheaper than wood, more durable. Special prices to churches and cemeteries. Don't buy a fence until you get our free catalog. Kokomo Fence Machine Co. 427 North St., Kokomo, Ind.

ANCHOR FENCE



All styles for FIELD AND LAWN. Best material and construction. Free sample and catalog. Dept. D, ANCHOR FENCE & MANUFACTURING CO. Cleveland, Ohio

POST-CARDS WITHOUT COST

We will send you the complete set of 24 Roosevelt In Africa post-cards if you will send us 10 cents each for two three-month trial subscriptions to FARM AND FIRESIDE. The two trial subscriptions must be new subscriptions. Send the 20 cents for the two subscriptions in coin or stamps.

FARM AND FIRESIDE
Springfield, Ohio

This Air-Rifle

Without Cost

This is the wonderful King Air-Rifle. It is a Repeater—shoots 150 times without re-loading. It is just the rifle for a Boy. Here is your chance—you can get it without cost.

Fill out and mail the coupon below and we will send full particulars by return mail.

For Our Boys

Would You Like to Get One?

You can get one without spending a cent. FARM AND FIRESIDE will help you earn it. You would be glad to do just a little work to get it. Thousands of happy boys already have earned a rifle easily from FARM AND FIRESIDE.

A True Shooter

Boys, this rifle shoots accurately. Look out, crows and hawks, if a boy ever gets after you with this King Air-Rifle. It cultivates trueness of sight and evenness of nerve.

It uses no powder—makes no noise—uses air and shot. You will have use for it every minute.

Expert workmanship has made this a wonderful gun. This rifle is provided with pistol-grip, true sights, and is so strongly made it is almost impossible to get out of order. It is extremely simple in construction.

Any child can use it and become an expert shot. It makes boys grow to be manly, self-reliant men. Every boy should learn to handle a rifle. It makes them healthy and strong—sends them out of doors.

Any boy would be happy to get this rifle. No wonder every boy should want one, we are glad to help every boy get one—without having to pay a cent for it.

How To Get It

We will send you this air-rifle if you will get eight friends each to give you 25 cents for a special 8-month subscription to FARM AND FIRESIDE, the best and biggest farm paper published. We will help you get them if you send the coupon below or just write a postal saying, "tell me how I can earn a rifle."

Send This Coupon To-day

FARM AND FIRESIDE, Springfield, Ohio.
Please tell me how I can get the famous King Air-Rifle without having to pay a cent for it.

Name

Address

Mail the Coupon for full explanation of our great 10 day free trial offer.



Sharpen Your Tools At MY Expense!

I will send you a **Harman Special Carborundum Farm Tool Grinder**, with seven Genuine Carborundum Grinding Attachments, right to your farm for an absolutely **free trial** lasting 10 days.

I will guarantee that this Carborundum Grinder will **not** draw the temper from steel.

I don't want you to send me any money—not a cent. I want to make you an offer so **liberal that you simply cannot afford to refuse it.**

I will give you the use of this magnificent outfit for **ten days absolutely FREE**.—no red tape, no papers to sign, no obligations of any nature. Just get the outfit, use it for ten days just as though it were your own, on your own work, sharpen your sickles, plow shares, cultivator blades, scythes, axes—anything that is dull—then, if you wish, return it to me at my expense.

Now, I want to tell you why I am making this offer

We know that every progressive, up-to-date farmer realizes the advantage of always having sharp, bright tools to work with. You know how much more work can be done with tools which are always in good condition. You know how much easier your work is and how much longer your tools last. You know all these things and yet—you **DO** sometimes work with dull tools, don't you?

I want to prove to you that you can **easily** keep **all** your farm tools in good condition, **all** the time, with this wonderful, **simply wonderful** outfit which I will send you **free**.

Grind your tools better and 25 times quicker than with a grindstone. 4,000 revolutions a minute.

7 MACHINES IN 1

- | | |
|------------------|--------------------|
| 1. ROUGH GRINDER | 4. SICKLE GRINDER |
| 2. FINE GRINDER | 5. POLISHING WHEEL |
| 3. SAW GUMMER | 6. RUST REMOVER |
| | 7. HONE |

Genuine Carborundum (Dia-mond) Grinder—NOT an Emery Wheel

And Carborundum is the most wonderful abrasive in the world, even harder than the diamond. It is really manufactured diamonds, for it is made of the very same substances which go to make up the diamond. Carborundum is the most perfect grinding substance known. It is just as much harder than emery as emery is harder than ordinary chalk. A grinding wheel made entirely of pulverized South African Diamonds would not grind one bit better or faster than the genuine Carborundum wheels which we furnish with this superb machine.

Carborundum is an absolutely new substance. It is not simply a substance which is dug up out of the earth, in fact, it does not occur in nature at all. Carborundum is manufactured in the most terrific heat which man has ever been able to produce. A heat so great that it will actually burn up a common brick like so much gun powder. And in this incomprehensible heat is produced Carborundum. **It is the heat in which the worlds were formed.** Every one of the beautiful iridescent, needle-like crystals is so hard that it will actually scratch the diamond itself. It is these crystals which are crushed up and made into the grinding wheels. It is these inconceivably hard and sharp crystals which cut through the hardest steel more easily than the finest emery wheel will cut through soft copper.

SAVES TIME—EFFORT—MONEY!

You can do the same work in two minutes on a Carborundum wheel that would take you at least a half an hour on a grindstone, and do it better. **And you can operate The Harman Special Farm Tool Grinder for half an hour with less effort than would be required in running a grindstone for two minutes.** Carborundum will grind 25 times faster than the grindstone and 8 times faster than the emery wheel.

We want to prove these things to you and at our expense. We want to send you the Harman Special Farm Tool Grinder for a ten days' trial right on your own farm. See for yourself how it will grind and sharpen every tool on your farm. See for yourself that it is time to throw away the grindstone. Send the free coupon for our free booklet describing this wonderful substance Carborundum. *Mail the coupon today.*

LASTING—BINDING—GUARANTEE

Carborundum wheels are so much harder than the hardest steel that no amount of grinding seems to have the slightest effect on them. Carborundum will cut the biggest steel file you have in two in five seconds. We give a lasting, binding guarantee with every tool grinder.

Carborundum will NOT draw the temper from steel

Carborundum wheels will not wear in spots or become lopsided. They will not glaze over. They are not only hard, but they are equally hard throughout. There are no soft spots in a Carborundum wheel. Many have been in use for 10 years and show hardly a bit of wear. Carborundum wheels will positively not draw the temper of the finest tool. The reason for this is that Carborundum does not heat the article which is being ground as does an emery wheel or a grindstone. Carborundum cuts and cuts quickly—it cuts so quickly that the steel does not have time to heat.

HARMAN SUPPLY CO.,
Dept. 3544, 160 Harrison St., Chicago, Ill.

Without any obligations on me please send me **FREE** your catalog explaining your Carborundum Special Farm Tool Grinder, also full particulars of your ten days' **FREE** Trial Offer, also the interesting story of Carborundum.

Name

Address

NO LETTER IS NECESSARY; JUST SEND THE COUPON

THOUSANDS IN USE

Read These Letters of Praise

Best For All Kinds of Tools

Enclosed you will please find money order for Harman Grinder which I received about ten days ago. Will say that I have tried it on everything from a razor to a plow point and am well pleased with the machine. It is the most complete section grinder I ever saw, and for grinding all kinds of tools I never saw its equal.

W. L. PRYOR,
Titusville, Ind.

Abused But Still Works Well

We think the grinder is a great machine. It does fast work; we have tested it to the extent of abuse, but all rough tools yield to it; just what is claimed for it.

HOOVER & PERSHING,
Muncie, Ind.

Beats All Grinding Machines

The Harman Grinder arrived yesterday in good shape. I put it together and tried it on a set of mowing machine bars, and I was astonished at the work it did. It beats all the grinding machines I ever saw, and I have seen at least six different kinds. I can set the bar holder just right and it will grind two sections on the side of the stone without touching it (the bar). I also tried the grinder I found five cold chisels and a center punch, which as usual with all farmers, were as dull as possible, some of them being one-eighth of an inch on the edge. I ground them to a fine edge and finished a very smooth fine edge on polishing wheel, and just think, I was just 12 minutes and did not hurry at all. And you know cold

chisels sent out with mowing machines are generally tempered pretty hard. I am certainly going to keep the machine, and if I could not get another I would not take any money for it.

PHILIP CARLYOU,
Dunkirk, N. Y.

She is a Dandy, Very Well Satisfied

I received your machine all right and am very well satisfied; she does better than I expected. She is a dandy. Every farmer ought to have one.

ANDREW GINHAL,
Brainerd, Minn.

Cuts Steel Like Wax

Enclosed please find check for the grinder. I am very much pleased with it and I find it cuts down steel as fast as wax in a fire. Thanking you for your attention and living up to your advertisement, I am,

A. SIMPSON,
Cambridge, Mass.

Makes Cross Cut Saw Good as New

I received your tool grinder the 20th and have given it a thorough trial. It does the work fine. I have gummed a cross cut saw and it is as good as new. The Harman Grinder is a dandy, and I would not be without one.

S. A. BAUGHMAN,
Bloomfield, Ia.

It Cuts Splendid

I received the grinder on the 16th inst., have tried the tool wheel and it is O. K. I like the way the machine works as far as tried; it cuts splendid.

C. J. TOWELL,
Annville, Jackson Co., Ky.

SEND THIS FREE Coupon

Remember 10 Days' Free Trial

Send the Coupon Today and Get our Grinding Tool Catalog **FREE**. Also our free booklet explaining all about Carborundum, the newest and most wonderful substance known.

Don't wait a minute. Send the free coupon today and post yourself on this wonderful offer. Learn all about the Harman Special Carborundum Farm Tool Grinder. Sharpen every dull tool on your place positively free. **We let you keep the machine for 10 days, and then if you wish, send it back at our expense.** But mail the coupon today and get our free booklets and circulars, and get our **FREE** trial request blank. There is no obligation. You will be amazed at the wonderful results you will get from using Carborundum. Anything you sharpen is sharpened better and quicker. Send for our free booklets today. Let us tell you what Carborundum is and what it will do with every tool on your farm. Get our free booklets and our special limited offer. Remember 10 days' free trial.

SEND THE FREE COUPON NOW.

HARMAN SUPPLY CO. 160 Harrison St. **Chicago**
Dept. 3544



FARM AND FIRESIDE

THE NATIONAL FARM PAPER



ESTABLISHED 1877

MAY 10, 1910



“Power on the Farm,” a Series of Valuable Articles by M. O. Leighton, Begins in This Issue

With the Editor

AT THE Conservation Congress the writer made conversation with a farmer from near Moorhead. He was a middle-aged Scandinavian, who had been for a long time a subscriber to FARM AND FIRESIDE. He was rather well-to-do, as it seemed, and doing pretty well on a farm of a quarter section admirably adapted to grains and clover. A solid, competent, intelligent man, of the sort with which that section is so richly blessed.

"Why do you take FARM AND FIRESIDE?" he was asked.

"Because it pays," he answered.

"Do you carry out the advanced ideas taught in its columns?"

"Some of them," he said. "But I ain't fixed to take up with all of them. I don't farm the way I used to, but I took up the new ways a little at a time. I know a thing sometimes for years before I do it. Some things I never do, when I know I ought to. Our soil is pretty rich and we don't have to be so awful careful of it."

"Of what use is the paper to you," queried the editor, "unless you follow its advice?"

"Well," said he in effect, "I use the paper like a business man uses his lawyer—I advise with it. I ask it questions. I keep a note-book in my pocket, and while I work I think. When anything comes up that I don't feel clear about, I write and ask FARM AND FIRESIDE. I keep the answers to the letters in a file I bought for a quarter, under the names of the department in the paper that they belong to—Live Stock and Dairy, Farm Notes, Poultry or whatever it may be. All these letters are about things relating to my own farm. I may not always think they are the best advice, but generally I find that they are worth following. A good deal of the knowledge I have of my own farm and my farming I have learned from these letters. They are worth a whole lot more to me than the papers themselves. My wife and girls read the paper more than I do, but I get the advice of trained experts on things that bother me, for the price of my subscription. It's worth a dollar for three years to me to have a lot of trained, practical farmers and college professors to ask questions of, even if I don't always follow their advice. Maybe I'd do better if I always followed it."

Now here was a man who was living up to one of his opportunities with his paper. He was in one way really using it. He had filed away a plan for replanning his farm for a scientific rotation, and more intensive farming, which one of our experts had made for him. And on further conversation, it transpired that he was following the ideas imbibed from these columns much closer than one might at first have thought from his remarks.

The mail which comes to this office bears thousands of letters every year which we answer directly, as we answered most of his, without any note of it in the paper. It is only when the query is of general interest that it is answered in print—but it is always answered. We have on our subscription-books the names of men and women whose correspondence has cost us more in labor and postage than their subscriptions amounted to.

Are we displeased at this? Why, bless your souls, no! We like it. It is the one part of the expense of running the paper which we like to see grow. We should be glad to add another clerk to the payroll to-morrow, just to receive and classify this correspondence.

Why are we glad to do this seemingly unprofitable work? Is it because we are unselfish? No. We are as selfish as most people. We like to do it, because it pays in the long run. It is the deepest principle of human labor that there is nothing which is ultimately profitable but service. The occupation which is not service will sooner or later fail to pay. If FARM AND FIRESIDE could do something to make it serve its subscribers twice as well as it now does, it would soon become four times as popular as it is.

Moreover, by your questions you educate us and make us better able to make a good paper. Every question is a peep-hole through which we can see the inner needs of one farm.

Such glimpses are worth much to us. They educate us as much as we educate you. Maybe more.

If your questions should cease to pour in, for a single week, the editorial force would be frightened. We should begin to inquire for the reason. It would be like passing a friend on the road and receiving no answer to our "Good-morning." It would be like having an accustomed service refused. That is, it would mean that something was wrong—radically wrong.

FARM AND FIRESIDE is one of the greatest intelligence offices, one of the busiest bureaus of information anywhere. It has the ambition to be still greater and still busier. It might easily be such, if one in ten of our readers should get the Minnesota farmer's habit of using the paper as he might.

We're here, hooked up to help. If you don't ask for it, it must mean one of two things. Either you are buying something which you are not receiving—by not asking for it—or your knowledge of the complex business of getting the most out of your farm is so exhaustive as to place you beyond the need of advice.

If the former is the case, a word to the wise ought to be sufficient.

If the latter is the reason, please send us your address. We need people who know it all to help answer the letters of those who don't.

This matter of the relations of the farm paper with its subscribers is something new in the world. Do you know that the good farm papers of this nation are the only ones that apply the Golden Rule to their readers as regards advertisers?

Look into it, and you will see that this is so. You take a daily paper, probably. If so, look at the advertisements. See the flaring advertising of patent nostrums that are whisky thinly disguised or opium to be administered by ignorant young mothers to their babies. See the displays of so-called specialists who live by exciting the terrors of people as to their health, and then sucking their blood in fees. See the get-rich-quick schemes flaunted to rob the ignorant or gullible of their earnings. The paper may be edited and owned by men high in business and social life, but in taking such advertising it is as much in league with crime as if it received stolen goods.

Don't think for a minute that we are ignored by the advertisers having such things and such dis-services to sell. Far from it! We could fill these columns with questionable ads. next issue if we would, at rates far above our regular ones.

I like to think that the reason of this is at least partly because the men who own and make the best farm papers are on a higher plane of business morality than the men who own and make the daily papers and most of the magazines. I like to think that in assuming this attitude the best farm papers occupy high ground to which the daily and magazine press will one day rise. I hope that the time will one of these days come when men will no more be allowed to send poison into the homes of the land in the form of advertising, and excuse themselves by saying that they were paid for it!

I hope that some day, and that soon, the thief and swindler will be as rigidly excluded from the respectable man's newspaper, as from his parlor. I hope the day will soon come when there be no avenue of publicity open to the fraud and the fake.

Whether or not this is to come true, the time has even now come when the readers of this paper may accept the assurance that its advertisers have been fanned and winnowed to remove all who are not worthy. We have the courage of our convictions that this is so, and guarantee our subscribers against loss by the failure of our fanning-machine. When you say to one of these advertisers, "I saw your ad. in FARM AND FIRESIDE," you have taken out a policy of insurance against crookedness.

When every newspaper and magazine in the land does the same (and they will be doing nothing more than their plain duty), the advertising in their columns will be purged of its impurity and purified of its fraud. And that will be a reform well worth while.

Robert S. Grier



Scratch Our Back and We Will Scratch Yours

To introduce Farm and Fireside to your neighbors who are not now subscribers, the editors make you this unusual offer: Get two people each to give you 50 cents for a year's subscription to Farm and Fireside. Send us the one dollar, and in return for the favor we will send you Farm and Fireside for one full year without cost after your present subscription expires. (If you are not now a subscriber, your own subscription will be entered for one year without cost.)

FARM AND FIRESIDE, Springfield, Ohio.

FARM AND FIRESIDE

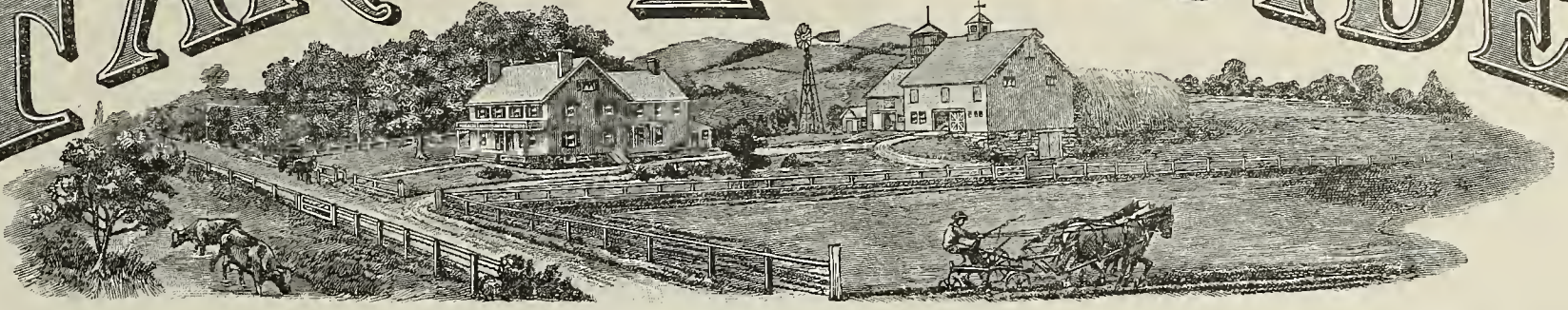

Vol. XXXIII. No. 15

Springfield, Ohio, May 10, 1910

PUBLISHED
SEMI-MONTHLY

How to Use Your "White Coal"

By Marshall O. Leighton

This article is the first of a great series which will place before our readers the best methods for supplementing muscle power with machine power on the farm. Mr. Leighton is Chief Hydrographer of the United States Geological Survey. Among hydraulic engineers he has an international standing as an authority, and in matters of farm power he speaks as a specialist. EDITOR.

AROUND the big cotton-mills of the south, that have so changed the industrial complexion of that region during the past decade, one finds row upon row of wooden structures, identical in design, fairly liberal in construction and modern in equipment. These structures are the homes of the mill operatives. They form communities, usually of a high moral tone and, to all outward appearances, pervaded by peace and contentment. To the extreme credit of the mill corporations, they have grasped the fact that it is the well-housed, well-satisfied workman who is the productive employee. With due regard for religion, education and morality, these corporations have established or fostered churches and schools. They have shut out the saloon and have maintained a watchful, though not officiously paternal, eye over the habits of individuals.

The mill-hand of such a community is the native American who has come from the farm, bringing his wife, sons and daughters. Each one who has entered these places of industry has thereby reduced the number of native Americans in agricultural pursuits. A step inside of one of these community homes will reveal the fact that, notwithstanding the advantages already enumerated, there is much that might be desired and which the old farm life must have furnished. If the ex-farmer be asked why he exchanged the freedom of his acres for the cramped quarters and the fifty-foot lot of a mill community, there is but one reply; with all pretenses and evasions exhausted, there is the final phrase: "Tired of farming."

Why is this so? What is there in the farmer's life that leads him to prefer the grind of machinery attendance and the conventions of a gossipy village? Carry the question further. Ask the farmer or the farmer's boy as he sits in his narrow room above the roar of the hot city pavement. He, too, is "tired of farming" and seeks repose in tumult. In every calling, in every environment, we find former tillers of the soil, living under conditions in a thousand ways inferior to, and with prospects in no wise as good as, those of the earlier days; and all with the same pretext. Why is this so?

There are many reasons, oft-quoted and discussed, but, after sifting, in almost every case one reason remains. It is the steady grind of manual labor. However rugged and willing a man may be, the constant toil of the small farm brings gradually an irksome discontent, beside which the lighter labors of a position of smaller opportunity appear altogether attractive. It is true that modern farming implements have accomplished much in the lightening of this load; but they have not relieved and cannot relieve the burdensome succession of comparatively trivial tasks that come daily and tax muscle and sinew. It would change the farmer's point of view if he could accomplish these tasks quicker. Anything that will insure him a fair share of diversion and recreation is calculated to increase his productivity and in proportion increase his profits.

The use of power has revolutionized almost every occupation but that of the small farmer. In varied forms, it has been utilized on the great ranches of the West; but, except in comparatively few instances, Eastern and Southern planters are still doing heavy

manual labor or are hiring it done at high rates. More than a million farmers are bending their backs over pumphandles. Hundreds of thousands more are chopping, sawing and splitting their firewood by hand and stacking their hay with a three-tined fork. A trip over some sections of the country will show a surprising number threshing grain with the flail. The cutting of fodder, the sharpening of blades and a score of other duties are each and all done by the expenditure of muscle. Each, in itself, may amount to little, but all combined figure largely in the burden of the day.

Discontent is by no means confined to the head of the family; it extends to the wife and the growing children. In thousands of cases the farmer has sought and found other means of livelihood in response to

of the small water-power, the appliances necessary and the cost of installation. Small water-power privileges are located on thousands of farms in every part of the country. The energy which might be developed at small cost and put to a score of profitable uses is going to waste. The discussion will lead into the various methods by which the farmer with power at his command may perform not only his own work, but that of his neighbors with profit. Following this will be taken up the various types of power engines that are simple in operation—the gasolene-motor, for one. A chapter will be devoted to the hydraulic ram, the machine that never sleeps.

The common rejoinder that will be made to the proposals in these articles will be, "I cannot raise the money to buy all these things." The answer is, "Have you ever tried?" The majority of men who fail to prosper do so, not by reason of lack of ability, but because of lack of knowledge concerning the extent of their abilities. It never occurs to them to reach out or else they are deterred by the bad example of those who reached too far. Yet the actual number of failures compared with the number of successful attempts is very small.

It should further be borne in mind that an investment of this kind, when considerably made, is a means of increasing productiveness as well as increasing comfort. Few farmers in this day hesitate in investing in a mowing-machine. By some means, they procure one. The reason is that by so doing they are enabled to harvest more hay. The investment for power appliances should be considered in the same way. While they may not in all cases return an actual financial income, they will serve to give the farmer more leisure and more comfort. They will give him a chance to get a grip on himself and thus to attack his daily problems with confidence and wisdom.

Harnessing the Rivers

Water-power privileges are of two kinds. The first is the one that most commonly suggests itself—namely, the cataract. Where a brook or a river goes tumbling down over the side of a ledge, the roar, the foam and the spray immediately suggest power. No argument is needed to convince any one of the fact that energy is being wasted. The second kind of power privilege is not as noisy as the first. Many a farmer has been making a daily journey over his property for years and has not yet noticed that he owns a water-power. Such a privilege is afforded by a stream whose channel runs sharply down hill and whose water makes no clatter except a low ripple murmur, but which, nevertheless, may furnish more power than the picturesque cataract.

We will take, for example, two streams. On one there is a cataract ten feet high. A column of water going over this ledge will develop, we will say, one hundred horse-powers. On the other stream there is no cataract, but the river falls ten feet in a horizontal distance of five hundred feet; that is to say, if we start at a certain point on the stream and walk down the channel, we will, when we have walked a distance of five hundred feet, be on ground ten feet below that on which we started. The power developed on that stream by a quantity of water equal to that which falls over the precipice is one hundred horse-powers, or exactly the same as the cataract. The difference lies in that, whereas the power of the cataract is concentrated in one place, that in the other stream is distributed all along the five hundred feet of channel. At any point along this channel there is some power, but the amount is too small to use. To get the full power we would have to add these points together. The principle is the same as that illustrated by driving a spike

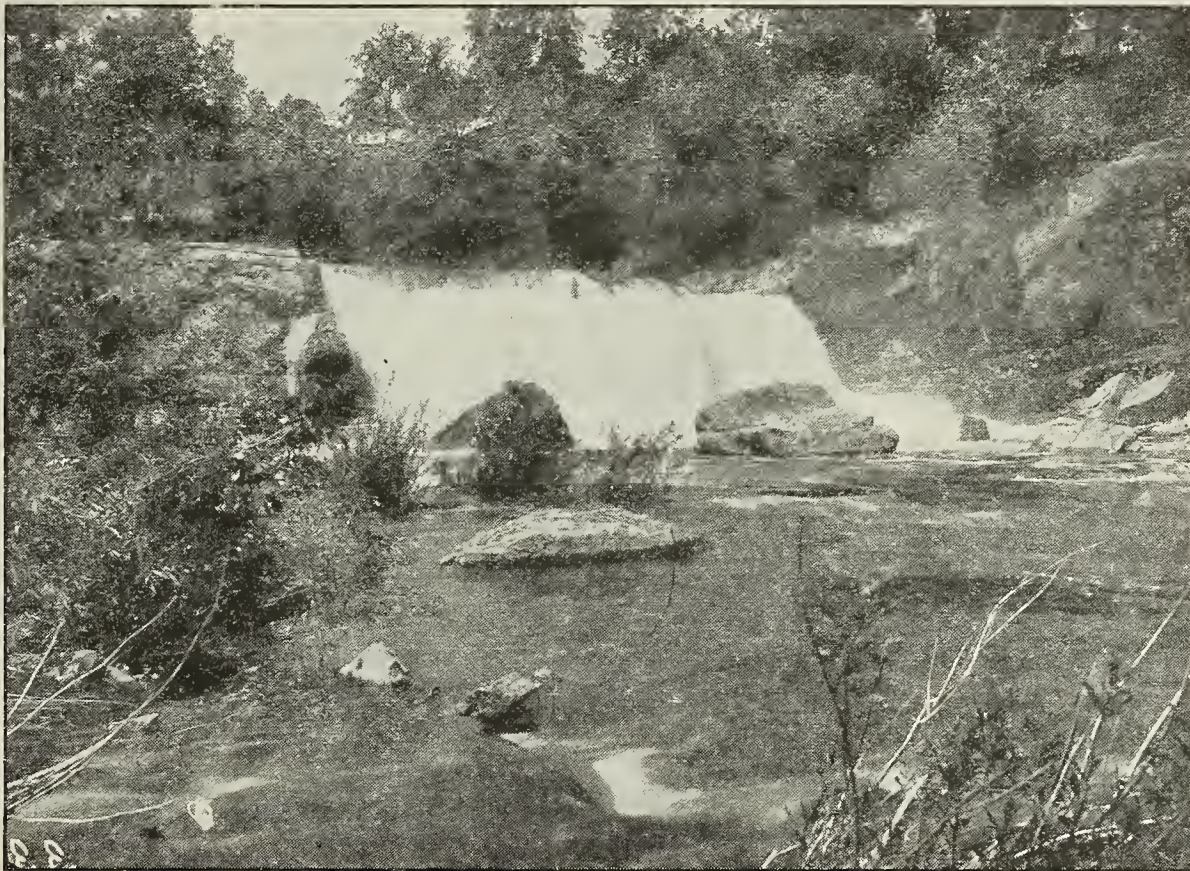

"The roar, the foam and the spray immediately suggest power"

the demands or oft-expressed wishes of his dependents. Nor is the reason far to seek. The average farm-house is not a model of comfort and convenience. It lacks the equipment that every town housewife now considers essential. The toil incident to the duties of the farmer has the ameliorating quality of variation; that of the farmer's wife is dull routine. We shall explain how power on the farm may be used to her advantage and comfort, all of which will change her point of view toward farm life.

The son, just reaching maturity and leaving the farm for the city, is another victim of discontent. He goes for the same all-sufficient reason, "tired of farming." It is true that our great industrial leaders are drawn from the farm, but they are the pick of the flock and sad is the process of culling. The great majority are in nowise as well off, morally, physically or financially, as they would have been had they remained at home.

For all those millions whose daily life on the farm partakes in greater or less degree of the conditions above described, this series of articles has been prepared. The ultimate purpose is to teach how a ready adaptation of forces and means at hand or to be cheaply purchased may lighten the load, increase the profits and render the life of the average farmer so much more attractive than it is to-day, that the call of the mill and the counting-room, the city street and the cramped living quarters will be less enticing, that we may conserve for the ultimate good of the nation its greatest resource of bone and sinew, courage and character—namely, the native American farmer.

It is proposed to consider the development and use

If one tries to drive it with a small tack-hammer each blow of the hammer will make very little impression on the spike, but if the blows be repeated long enough the spike will finally be driven home. On the other hand, if the spike be struck properly with a twenty-pound sledge it will go home on the first blow. But the energy actually consumed in driving the spike home with the small hammer is the same as that with the sledge. So it is with the two power privileges. In the case of the cataract we get in the sledge-hammer blow, while in the case of the five-hundred-foot channel the power is made of numerous small units corresponding to the blows of the tack-hammer.

Now, the cataract water-powers are comparatively rare; but streams of steep slope abound in almost every section. Therefore it behooves every farmer who has a stream running across his place to examine it carefully for power. But how shall such a stream be developed so that it will strike the sledge-hammer blow? Let us see.

We must transform our stream into a cataract. The process is very simple. It is merely necessary to start at the head of the stretch of swift water and build a flume that will run almost level to the foot. Of course, it will be necessary to give the flume some slope, but a few inches distributed over the whole distance will be sufficient. A flume built in this way will, by the time it has covered the five-hundred-foot stretch, be almost ten feet above the level of the stream at that point. Then it is merely necessary to turn the water from the stream into this flume at the upper end and we shall have the water coming out in a cataract at the lower end. We will by this method have concentrated almost all the fall over that five-hundred-foot stretch into one place. The power produced will be as good as though it were produced by a natural cataract.

Have You Power on Your Farm?

We will now take up the various steps by which any farmer may determine whether or not he has a water-power on his property. There are, in general, two factors governing water-power: The first is the fall and the second is the quantity of water. The fall is easily determined, either by use of the surveyor's level or by more simple methods. As the services of a surveyor can always be commanded in practically any locality, for a reasonably small fee, it is far better to engage one. The results of an instrumental line of levels such as a surveyor makes are more satisfactory, especially in case of sale, transfer or suit at law. If, however, for any reason it is inexpedient to procure a surveyor's services, the slope of a stream may be determined approximately by the use of the ordinary carpenter's level. There are many methods by which this may be done. The one described below is as simple as any, and will give results accurate enough for the purpose.

Select a board six to eight inches wide and ten to fifteen feet in length, with straight and parallel edges. The exact length should be carefully measured. A suitable place for a starting-point should be selected on the bank of the stream at the head of the stretch of swift water. This point should be made fairly permanent by driving a stake into the ground so that the top thereof will be practically level with the ground surface. Then proceed with the leveling as follows:

The board should be used "edgewise"—that is, the two edges should be horizontal and the two flat faces vertical. One end should be placed on the top of the stake and the other end extended over the water surface. The level should be placed along the top edge and the end extending over the stream raised or lowered until the bubble is centered. The board is then supported in this position by placing under the water end a staff or, better, a crotched stick. Then swing a plumb-line and bob down from the lower edge of the board until the lower point of the bob just touches the water surface. The length of the line from the bottom of the board to the bottom of the bob gives the height of the stake above the water surface. This distance should be carefully set down in a note-book.

Starting again with the first stake, a distance equal to the length of the board should be measured off and at that point another stake like the first should be driven into the ground. This should be continued until the entire distance is covered, and the course marked off by a line of stakes, the distance between each being equal to the length of the board. As straight a course as possible should be taken from the start to the finish, without regard to the stream course except that it will usually be convenient to so direct the course of the stakes that they will all be on the same side of the stream.

The levels from one stake to another should be taken in the following manner: One edge of the board is placed on the first stake, as above described, and the direction of the board is swung to the next stake. The level should then be placed on the top of the board and the lower end raised or lowered until the bubble comes to the center. Support the board in this position and measure with rule or line the distance from the lower edge to the top of the second stake and record the result in the note-book. The upper end of the board should then be brought down to the second stake and the same measurement should be taken on the third, and so on, until the end of the course is reached.

There will then be in the note-book a record of the difference of level between the various stakes, the sum of which differences will, of course, give the total difference of level between the first stake and the last. Wherever possible, the course of the stakes should be chosen so that each will be lower than the one preceding, so that the simple addition of the various differences in level will equal the total of difference. There are conditions—for example, those in which the stream cuts through a hill or ledge—in which it may be necessary to go up-hill for a certain distance and then down in order to cover the course of the stream. All these up-hill measurements should then be subtracted from the sum of the down-hill ones and the result will be the correct total difference in level over

the whole stretch. Finally, the height of the last stake above the water surface of the stream at that point should be measured in the same way as described for the first stake.

It will be remembered that in starting the level measurements we first took the elevation of the first stake above the water. Assume this was three feet. We will likewise assume that the elevation of the last stake above the water was two feet. Let us further assume that the total difference in level between the upper and the lower stakes is ten feet. It should be clear then that the total slope of the bank is greater than the slope of the stream-bed. But it is the stream-bed slope that we want. We would then subtract the lower from the upper, or two from three, and the difference, one, would be subtracted from ten, which gives the total fall of nine feet in the stream. Supposing, however, that the elevation of the last stake above the water were six feet instead of two feet. Then the proper procedure would be to subtract three from six and to add the difference to ten feet, making thirteen feet fall in the stream. In other words, when the elevation of the last stake above the water is less than that of the first stake, subtract the difference from the total difference in elevation of the first and last stakes; when the last is greater than the first, add the difference.

Having determined the slope of the stream, it now becomes necessary to measure the amount of water.

Every one knows that streams are sometimes high and sometimes low. It follows that the amount of power any stream will develop changes from high to low, according to the amount of water. It should be plain that, in developing a stream for power, the equipment installed should not be of size sufficient to take care of the extreme high flow, because this high flow persists only a short time and during the remainder of the year a great part of the equipment would be idle. On the other hand, an equipment sufficient to utilize only the extreme low-water flow can be kept busy throughout the entire year. In times of high water all the flood in excess of that which can be used by the equipment can be sent down the stream without passing over the wheels. This, however, will involve a loss. Even as the flood period lasts only a short time, so the extreme low flow is at the most only one or two months long. A large amount of power over and above the low flow is available during the greater part of the year. On the farm it is profitable to have machinery of sufficient capacity to use all the power that is available in, say, six or eight months of the year. Machinery should be installed that will utilize the low-water flow, so that some power will be available at all times, while at seasons of higher water (not extreme floods) the full power afforded by the machinery may be used to provide for extra power



A Swift Stream Properly Harnessed Equals a Cataract for Power

and the farmer can so arrange his work that he can use the power when it is available.

The foregoing statements readily suggest that in measuring the flow of the stream one should select a time at or very near the low-water period. Having determined this low flow, a water-wheel can be installed that will utilize it and also be able to handle an amount of water equal to, say, twice that of the low-water flow. For ordinary farm uses a turbine that will operate with twice the low-water flow will also provide during the extreme low-water period sufficient power for all ordinary purposes. Of course, in the establishment of commercial powers the capacity of the turbine is determined far more accurately than this; but on the farm that simple rule will generally suffice.

Taking Stock of Available Water

Having chosen the time at which the stream is near the low point, we proceed to measure the amount of water.

For all power calculations the amount of water in a stream is expressed as the number of cubic feet flowing in one second, and to determine this it is necessary to have the speed of the water and the area of its cross-section.

The cross-section of any stream is the area in square feet found by multiplying the width of the stream by its average depth. Consider, for example, a trough one foot wide and one foot deep. If water were run through this trough so that the surface would be just level with the top, the cross-section of that stream would be one square foot—that is, the width, one foot, multiplied by the depth, one foot. Now, if we assume that the water in this trough were running at a speed of one foot per second, we would merely have to multiply the cross-section area above determined by the speed, one foot per second, and we would have the flow, in this case one cubic foot per second. The same method applies to all other streams.

We take a certain stretch of the channel, say one hundred feet in length, fairly regular in width and depth, and without curves or bends, and first determine the depth. Of course, the depth is greater at the

middle than at the sides. Therefore, it is necessary to take a number of observations across the stream. We begin, say, about one foot from the edge of the water on one side and take the depth there, then at a distance of another foot toward the center of the stream, and so on, until the other side is reached. We would then have ten or fifteen depths, which should be added together and divided by the number of depths plus two, for the average. This would represent the depth of the stream from side to side. Multiplying this result by the average width of the stream, from one edge of the water to the other, we have the area of the cross-section.

Having determined the cross-section, it then will be necessary to determine the speed of flow. For this purpose the one-hundred-foot section along the uniform channel above described should be measured carefully and staked off. A block of wood, say two inches square, should then be thrown into the stream above the upper stake and near one of the shores. The observer should stand at the upper stake, watch in hand, and when the block of wood crosses the line the minute and second should be carefully noted. A stopwatch, of course, is useful. Having noted the time at which the block crosses the lower boundary. The number of seconds required by the block to pass over the one-hundred-foot stretch should then be figured. The block should be recovered, or another one similar to it used, and the process repeated, each time placing the block a little farther from the shore than before, until, by placing the block at different positions, say one foot apart clear across the channel, the entire series of measurements are taken. All the results should then be added together and the sum divided by the number of observations and this will give the average number of seconds required by the stream to flow one hundred feet. If now we divide one hundred by this number, we shall have the number of feet per second that the stream flows.

A Sample Computation

But this measurement was made at the surface, where the water flows faster than it does at the bottom and sides. A measurement of speed at the surface gives a higher result than the whole stream actually accomplishes. The difference is about one tenth. Therefore, we must divide the above result by ten and subtract the amount from the original figure, and the result will represent the average speed. This should then be multiplied by the cross-section area and the final result will be the discharge in cubic feet per second.

The computations are illustrated below, assuming that our stream is of an average width of ten feet.

DETERMINATION OF CROSS-SECTION AREA

1 foot from water's edge	4 inches deep
2 feet from water's edge	12 inches deep
3 feet from water's edge	9 inches deep
4 feet from water's edge	14 inches deep
5 feet from water's edge	15 inches deep
6 feet from water's edge	11 inches deep
7 feet from water's edge	7 inches deep
8 feet from water's edge	6 inches deep
9 feet from water's edge	3 inches deep
Total	81 inches

As there were nine points of measurement and two shore points of zero depth, average depth is about seven inches. Cross-section area equals six and a fraction square feet.

DETERMINATION OF SPEED OF CURRENT

1st block traversed 100 feet in	20 seconds
2d block traversed 100 feet in	17 seconds
3d block traversed 100 feet in	16 seconds
4th block traversed 100 feet in	19 seconds
5th block traversed 100 feet in	21 seconds
6th block traversed 100 feet in	17 seconds
7th block traversed 100 feet in	19 seconds
8th block traversed 100 feet in	20 seconds
9th block traversed 100 feet in	22 seconds
Total	171 seconds

As there were nine blocks, the average speed would be one hundred and seventy-one divided by nine, or nineteen seconds. As the water traversed one hundred feet in nineteen seconds, the distance traveled in one second would be one hundred divided by nineteen, or about five feet. But, as above explained, this is the speed at the surface. It must be reduced one tenth to give the average speed of the whole stream. One tenth of five equals one half. Five minus one half equals four and one half, which is the final speed figure.

We have a cross-section of six and a fraction square feet, and speed of four and one half feet per second. The discharge will be the result of multiplying one by the other, or about twenty-seven cubic feet per second.

It should be understood that the above figures do not apply to any special case. They are merely random amounts set down in order so that the process may be clear. The reader should, therefore, follow the process rather than the actual quantities.

* * *

Making a living is a small thing beside the making of a life worth while.

The farmer of the future will be on an intellectual equality with the doctor, lawyer and minister.

Many farmers hire a hand simply because he can turn off a large amount of work, no matter whether his actions or language are fit for the children to model after or not. This is criminal negligence and indifference.

When I pay a man, I always get a receipt, record all particulars in my farm log-book and file the receipt away, and when the man dies or goes out of business, seal up all his receipts in a special envelope and mark with his name, and keep.

How Orientals Solve the Fuel Problem

Crops That Supplement Wood and Coal—By Prof. F. H. King

IN FEBRUARY, 1905, before the annual meeting of the Missouri State Board of Agriculture, we said, "With the vast and ever-increasing demands made upon the materials for food, for apparel, for furnishings and for cordage, which are the products of cultivated fields, better soil management must become more and more important as populations multiply. With the increasing cost and ultimate exhaustion of mineral fuel; with our timber vanishing rapidly before the ever-growing demand for lumber and paper; with the inevitably slow growth of trees and the very limited area which the world can ever afford to devote to forestry, the time must surely come when, in short period rotations, there will be grown upon the farm the materials from which to manufacture not only paper and substitutes for lumber, but fuel as well." We did not then know that, long before, such a stage of density of population and of demands upon the soil had been reached by the Mongolian race in China, Korea and Japan. Such, however, is the fact.

Not only is a large part of the fuel of the Far East grown upon the cultivated lands, but these people have adopted such customs and dress as permit them largely to dispense with the use of fuel in warming dwellings. The first illustration shows an aged Shantung farmer in winter dress. Observe his wadded, quilted frock and trousers tied about the ankles, belted at the waist, and his cloth shoes with thick felted soles. Beneath these outer garments there are, one cannot say how many, others, all thin—but, with the alternating layers of confined air which they insure, they conserve marvelously well the warmth of the body, making outside heat less necessary. It is estimated by missionaries of long experience that a farmer's dress in China, when once his wardrobe is complete, can be maintained at a cost not exceeding five dollars, Mexican, per annum, or about \$2.25, gold, meaning by this that after he has his outfit \$2.25 will keep it in repair and procure new garments and shoes as others wear out.

No Warming-Pans Needed in China

But the economies do not stop with dressing to make fuel for warmth alone, in the home, less necessary. Beds are laid on the chimney to absorb and utilize the warmth escaping from the kitchen. This is how it is managed: Instead of carrying the chimney directly out through the roof from the cooking-range, it is built horizontally along the floor through two or more sleeping apartments and built broad and high enough so that beds may be spread directly upon it. It is constructed from bricks twelve inches square, four inches thick, made from the clay subsoil of the fields worked into a plastic mass and mixed with straw or chaff. When dried in the sun they are laid up flatwise in mortar of the same material. These bed-chimneys are thus massive structures capable of absorbing the waste heat of the cooking for a whole day and of imparting congenial warmth to the bed and sleeping-apartments during the night.

Nor do the economies of the chimney-beds stop with the warmth utilized from them. Through the action of the heat, of the gases from the combustion and through the natural processes of fermentation between the soil and the chaff incorporated in the brick, the walls of the flue become, in three or four years, sufficiently porous and open so that the draft is so defective as to require that the chimney be removed and rebuilt. These removals and rebuildings require much labor, but the subsoil which has thus served in the chimney flues has acquired qualities making it highly esteemed for use in the preparation of the earth compost so much used in northern China in fertilizing the fields, and for this reason the large amount of extra labor thus necessitated is not regarded as either too large or as lost.

We know from our own observations that heating a soil increases the solubility of the plant-food it contains. It doubtless also improves its physical and perhaps its biological condition as well. These brick are very carefully worked into the compost fertilizers, after having been pulverized, and used on the fields.

There is another practice somewhat allied to this which is worth mentioning here, showing the economies of the people and growing out of the extensive use of earth floors. In course of time the soil of the floors, to a depth of several inches, becomes so strongly charged with lime nitrate through the process of nitrification as to render the floors wet and sticky through the absorption and retention of moisture, the lime nitrate being deliquescent, or having the power to withdraw sufficient moisture from the atmosphere to dissolve it. It then becomes necessary to replace this layer with fresh soil and there are men who make it their regular business to go from house to house in a village and purchase the soil of the floors to a specified depth, paying for it in proportion to the amount of nitrates present. This soil is then leached to recover the lime nitrates present, and the leachings are percolated through plant ashes for their conversion into potassium ni-

trate so extensively used in the manufacture of fireworks and gunpowder.

Rev. A. E. Evans, of Sungking, informed me that so general is this practice of niter-gathering in that portion of China that the government levies a license tax of eighty cents per month upon the man who engages in such a business, and an acquaintance of his, he learned upon recent inquiry, had sold eighty dollars'



"An aged Shantung farmer in winter dress"

worth of the manufactured nitrate as the product of four months' labor. Where the highly-nitrified soil of floors is not used in this manner for the manufacture of potassium nitrate, it is used, when removed, in the manner of the chimney brick, as fertilizer. Even the earth walls of houses, especially if they have been whitewashed, acquire rich accumulations of nitrates and these, too, are used for fertilizing the fields when, through accidents of fire or otherwise, the walls must be torn down.

The stems of all agricultural crops which are to any extent woody, unless they can be put to some other use, are consumed as fuel in the homes and in manufactures. Rice-straw, tied in bundles as seen in the second illustration, and cotton-stems pulled by the roots after the lint has been gathered are brought to the cities in enormous quantities. The stems of windsor beans, of rape and of the large and small

millet, as well as those of many other crops, are similarly used as fuel both in domestic economy and in the burning of brick, of tile for the roofs of houses, of earthenwares in great variety and pottery, as well as in the manufacture of oils, tea, bean-curd and a thousand other processes.

We witnessed the manufacture of cotton-seed oil and cotton-seed cake where rice-straw and rice-chaff were the fuel. In a large, low, one-story, tile-roofed building, serving at once as store, warehouse, factory and dwelling, a family of four generations were at work, all with faces of seeming contentment; the smiling old grandfather still at the helm in the mill and the grandmother leading in the home and the store where the cotton-seed cake and oil were selling at thirty-three cents, gold, and \$2.24, gold, per hundred pounds respectively.

Back of the store and the dwelling-rooms, in the mill compartment, three water buffaloes, blindfolded, were propelling three granite mills, grinding the seed. Three other cows for relay service lay at rest or stood eating, waiting the shift in the ten-hour working day. Two of these mills were of granite stones four feet four inches in diameter, the upper revolving upon the lower once with each circuit of the cow; the third mill was a pair of stone rollers five feet in diameter, two feet thick, mounted on a short horizontal axis three feet apart and made to roll upon a larger stone plate about a vertical axis between the two, thus securing both a shearing and a crushing effect.

After the seed had been twice ground, the meal was subjected to a steaming process by which the oil was rendered fluid so as to be more readily expressed. The steamer consisted of two screen-bottomed wooden pails fitting closely into openings in the top of an iron kettle of boiling water, the steam being forced through charges of the meal weighed in a scoop counterpoised on the arm of a bamboo balance to insure standard weight for the cotton-seed cake.

Light Fuels and Forced Draft

On the ground in front of the furnace sat a boy of twelve years steadily feeding rice-hulls into the fire with his left hand at the rate of thirty handfuls per minute, while with his right hand, in perfect rhythm, he worked the plunger rod of a long, rectangular box bellows, maintaining a forced draft. At intervals, too, the man bringing in the fuel would feed into the furnace a bundle of rice-straw, giving the boy's left arm a respite.

When the steaming has rendered the oil fluid, the meal is transferred to ten-inch bamboo hoops, two inches deep, made from braided strands and deftly packed with the bare feet under the weight of the body. When a stack of sixteen hoops, each separated by a sprinkle of straw or cut chaff to prevent the cakes uniting when under pressure, has been completed, these go to the press, one man charging the hoops for four press-men.

The presses consist of two parallel timbers framed together far enough apart to receive the hoops crosswise, on edge, sixteen in a set. The pressure is secured by three parallel series of wooden wedges forced against the hoops through the followers by three iron-hooped master wedges driven into the lines of the other wedges with a heavy beetle weighing twenty to thirty pounds. One line of wedges is tightened and then another, the attendants working back and forth, removing the loosened master wedge, adding extra smaller ones to take up the slack, driving the master wedge again, until the sixteen cakes, each acting as follower for the other in their elastic hoops, have been sufficiently compressed. By this very simple, easily constructed, inexpensive mechanism enormous pressures are secured, such as are only now possible through the modern costly hydraulic presses. When the desired pressure is secured, the operator lights his pipe, sits down to rest and waits for the oil to drip.

A second boy sitting on the floor was making wooden wedges to take the place of those worn out. So that, with the men tending the mills, altogether there were eight men and two boys, doing duty with the six cows working in relays of three. Six hundred and forty cakes constituted the day's work and these were selling at \$20.04, gold.

But fuel from the stems of agricultural crops has nowhere in these countries been sufficient to meet the needs of the yellow races even when they have reduced their demands for fuel to cooking and the manufactures, and so immense areas of mountain and hill lands are taxed to their limit in the production of fuel. Quantities of pine boughs, for instance, are gathered in the Shantung hill lands and brought down on mule-back to the plains cities and villages. In the use of these materials for fuel, as in almost every other line, the utmost economy and good judgment are practised, as they have been for centuries.

The hill and mountain lands, wherever accessible to the densely-peopled plains, have for centuries been cut over persistently and as regularly has afforestation been

[CONCLUDED ON PAGE 6]



"Rice-straw tied into bundles . . . and brought to the cities"



29 Years in service without repairs is the record of this

"PENNSYLVANIA" LAWN MOWER

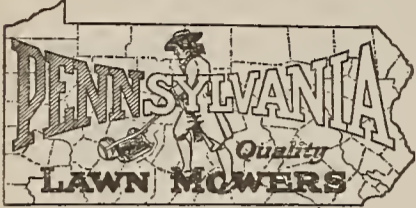

This is not the *only* "Pennsylvania" with such a record. There are thousands of others like it.

A "Pennsylvania" Lawn Mower lasts because the blades are made of the highest grade *crucible tool steel*—hardened and tempered in oil. It's the *only* mower in which *all* blades are of *crucible tool steel*. They're self sharpening, *always* in the best cutting condition. Castings are *ground true*.

If you want the "final word" on lawns and mowers, send for a copy (FREE) of our book—"THE LAWN—ITS MAKING AND CARE." It's from the pen of a well-known authority.

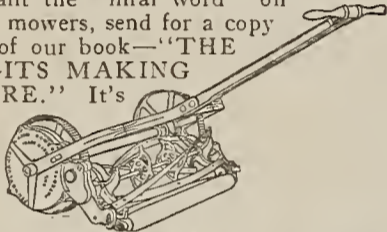

SUPLEE HARDWARE COMPANY, BOX 1580, PHILADELPHIA

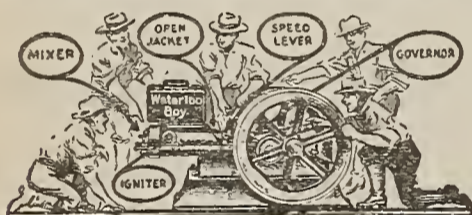

17 YEARS ON THE MARKET THE WATERLOO BOY HAS ALL THE GOOD POINTS THAT GO INTO ANY GASOLINE ENGINE 5 YEAR GUARANTEE

All gasoline engines have some good points, or there would be no sale for them and they would soon be taken off the market. Some engines have more good points than others, that's why some engines are better than others.

WATERLOO BOY GASOLINE ENGINES

have all the good points that go into any gasoline engine, besides many *exclusive*, patented features that increase their efficiency and durability; make them marvels of simplicity and wonderfully economical engines to operate. That's why we say the **Waterloo Boy** is the *best engine for farm use*. You can buy a Waterloo Boy for *less money* than you will be asked for engines containing half of the good points we build into our engines. Besides we will send a Waterloo Boy to any responsible farmer and let him try it for *thirty days* on his farm, doing whatever work he has to do. We will pay the freight both ways and return his money if after a month's use he cannot pick out the good points for himself—if he can't see that it is the one and only engine that will give him complete satisfaction. Better write us today for our catalog and free trial offer.

WATERLOO GASOLINE ENGINE CO. 173 W. Third Ave., Waterloo, Iowa 30 DAYS FREE TRIAL



Anthony FENCE

It always "sets" right because made right, with line wires of absolutely equal length—stays always parallel to posts. The famous Anthony Knot makes no kink in the line wire inside the knot.

WE KNOW HOW

to make the "Best Fence on Earth," and WE MAKE IT. We use the best hard steel spring wire—the best fence machines (built specially by us) and the most skillful workmen. Anthony Fence is a heavy, strong, service FENCE—not a wire netting. Prove this by asking for a small sample—write us to-day.

THE ANTHONY FENCE CO. 30 Michigan St., Tecumseh, Mich., U. S. A.

Success With Figs—By Prof. A. M. White

In the past most Gulf State farmers have grown fig-trees on a door-yard scale, but few have succeeded with them in commercial orchards. Now, given the right soil and culture, many are finding profit in figs. Fig-orcharding will probably never stand on a par with apple or orange growing; but for those who enter it with due foresight and knowledge it presents some attractive possibilities. EDITOR.

THE fig industry has reached such proportions that it can hardly be considered any longer in the infantile stage. At present the fig is grown throughout the entire Gulf Coast region and even farther inland.

During the early times of Spanish and French settlement the fig was introduced on the Gulf and Atlantic coasts, where it found climate and soil congenial to its full development, and there it is found growing in the open without any winter protection, bearing at an early age, as well as in abundance, on soil adapted to its culture. During very severe winters the trees may be frozen to the ground in some of the higher latitudes, but if the root system is well established, sprouts will spring up rapidly which will bear a crop the following year. Figs usually bear the first year from cuttings or on well-rooted one-year-old trees. In the intermediate counties, and where there is danger from winter killing, it is advisable to allow the trees to grow into bush form; from four to six shoots should be left, and low branching should also be encouraged for the protection from the hot sun in the summer and the cold of winter.

The fig will grow in a variety of soils, but delights in a warm, moist sandy soil rich in humus and an abundance of lime. The soil should be well drained to a depth of three feet; low-lying lands, which do not overflow for any length of time, are ideal for fig-orchards. The soil should be prepared by deep plowing with either a turning or a disk plow, then disked and harrowed down fine. The alluvial lands of the Mississippi Valley near the coast grow fine figs; these soils are retentive of moisture and are rich in lime and humus from decayed matter and the silt deposited for generations.

The fig is a surface feeder and is therefore difficult to cultivate on some soils without injuring the roots, but by cultivating deep from the time of setting out this trouble may be alleviated to some extent, since the deep cultivation causes the feeders to root more deeply.

In lining out the fig-orchard the rows should be laid off twenty feet apart each

way; this space allows ample room for cultivation and also permits the growing of various crops up to the third or fourth year. The holes for the trees should be dug deep and wide, generally about two by three feet. Never expose the roots of the fig to the sun for any length of time. Cut out all dead portions of the root which may be decayed or broken, and do not place the trees in the holes any deeper than they grew in the nursery. Fill in with good moist top soil, run a raised ring around the trees with a hoe and water copiously. A good drenching at the time of planting will settle the soil around the roots and cause the trees to become established much more quickly. After the water has all soaked in the ground, dust mulch the top with a few shovelfuls of dry soil to retain moisture. In the irrigated districts it is best to irrigate the land before planting and also around the trees after planting.

Figs will grow on thin soils, but a system of planting leguminous crops must be resorted to in order to keep up fertility and humus. The fig is a voracious feeder and will grow to a height of six to ten feet the first year. In the warmest sections of the coast country the tree can be pruned twelve to eighteen inches above the crown base and allowed to form into any shape desired, but only one main trunk should be permitted to remain, while the lateral branches should be trained for low heads. Do not allow weeds and grass to get a big start—keep clean by shallow plowing or harrowing.

Frequent pruning of the fig-tree is detrimental; the quality of the fruit is not in any way improved and the quantity is usually decreased. Prune only sufficient to shape the young tree, remove injured wood and thin out the head of the tree, but not too much—just enough to admit light and air. When pruning, make your cuts at a joint; but as a rule branches should be entirely removed, which prevents the tree from becoming irregular in shape and hastens the development of lateral branches. Pinch back the buds of young growing trees; this is desirable when low-branching trees are desired. The same effect can be produced by allowing two to four main stems to start from the root; the latter form of tree is less liable to break down under a heavy crop.

The Alvin and the Algoa districts are at present the leading fig-growing points in Texas. The time is coming when car-loads of fresh figs will be shipped packed in quart berry-boxes, thirty-two boxes to the crate, and shipped in iced

cars to Northern and Eastern markets for immediate consumption or to be held over in cold storage. The first growers to embark into a proposition of this kind will make some good money.

The fig, thus far, has been comparatively free from diseases on the coast, though "fig sour" is sometimes caused by prolonged wet weather; but it disappears as soon as the weather dries and warms up. The fruit-depredators are birds, wasps, ants and bugs; but do not begrudge the little fruit the birds eat—they more than pay for it by the destruction they visit upon insects injurious to other crops. Fungus diseases are few, and do not effect a great amount of damage. Leaf rust sometimes defoliates the tree, but does not accomplish a great deal of harm. Keep your trees nourished, but avoid the use of stable manure or any organic fertilizers; if any of the trees show signs of weakening from deficient nourishment, apply a top-dressing of nitrate of soda, using two to five pounds per tree and raked or harrowed in. Watch for the fig-tree borer—he works near the crown; dig him out with your penknife.

The fruit must be fully ripe before it is fit to eat; if not fully ripe, it should be peeled first, since the skin contains an acrid juice which has a tendency to make the lips and mouth sore. Do not bruise the fruit in gathering for the market; it should be handled tenderly and quickly. A great deal of the fruit can be reached from the ground with the hands, but for tall trees a simple home-made gatherer can be used to advantage. Take an ordinary tomato-can or any other can of convenient size and tack to the end of a pole; file a portion of the rim of the can to a sharp cutting edge and place in the bottom of the can cotton or some soft material to prevent the fruit from being bruised. The can may be tacked on the pole upright or at right angles, to suit. A step-ladder can also be used to good advantage in gathering. The wood of the fig is very brittle, so it is unsafe to climb the tree; the result will be broken and damaged limbs.

The cost of setting out a fig-orchard ranges from fifteen to thirty dollars per acre. The cost of preparing the land runs from ten to twenty dollars per acre, depending on the amount of timber on the land. The cost of cultivation is small; in fact, the crop planted in the orchard will more than compensate the grower in profits for his labor. Growers in favorable locations have reported profits of from two hundred dollars to four hundred dollars an acre, dating from the time the trees are four years old.

How Orientals Solve the Fuel Problem

[CONTINUED FROM PAGE 5]

encouraged or deliberately secured, even to the transplanting of nursery stock grown expressly for the purpose. We had read so much regarding the reckless destruction of forests in China and Japan, and we had seen so few large trees, that when Doctor Haden, an old missionary, insisted that the Chinese were deliberate foresters and that they regularly grew trees and transplanted them for fuel, we informed him that we "were from Missouri and would have to be shown," and a two-days' journey by house-boat in Kiangsu, beyond Moo Too, was planned to see the wood-cutting on the hills and the afforestation which follows. When we reached our destination and Doctor Haden began making inquiries of the people regarding the cutting of fuel from the hills and their replanting, the matter was so well understood that a little boy of eight years, listening to our inquiries as to where we might see some pine-tree nurseries, understood, and the lad did lead us up the hillside into the shady woods to two such nursery beds and we brought back photographs of them. Here the hillsides were owned in narrow holdings extending directly up the slope, some of them not more than thirty feet wide, and on one of these, which had been completely cut over the year before, taking out everything even to the roots, we counted eighteen young pines coming up as volunteers in a strip six feet wide by thirty long, extending across the narrow holding, and the whole strip on the steep slope was already well started and would be ready to yield another crop in five to ten years. Nowhere did we see stumps, but we often saw the trunks of large trees in the market, to be sawed into lumber, still bearing all of the main large roots. When these forest hillsides are cut over, everything is saved, even the roots, smallest stems and the leaves.

Much charcoal is made in these countries and this is even put into briquets, formed in molds of iron, compressed by hand labor by means of heavy blows on a steel ramming bar, small quantities of the powdered charcoal being added at a time until the mold is full; or both charcoal and coal-dust may be formed into balls in the hand as we shape snowballs, using a thin paste made of clay or a viscid fluid which is the waste of the manufacture of syrup from rice. There are enormous beds of coal in China and we might wonder why these have not been used to a greater extent; but it must be remembered that it is only since the introduction of cheap, rapid, long-distance transportation that the general use of coal by western nations as fuel has been rendered possible.

The prices of plant-stem fuels from agricultural crops we found ranging between \$1.30 and \$2.85, gold, per ton, when the price of anthracite coal was \$7.76 per ton; and the per acre value of these fuels ranged between \$1.03 to as high as \$8.51, gold. At Mukden the stems of the large millet, kaoliang, were selling, tied in bundles, at the rate of \$2.76 per ton, and fifty-six hundred pounds per acre was regarded a good yield, the grain associated with it bringing the gross earnings up to \$25.34, gold.

While the world extension of rapid cheap transportation and the utilization of mechanical appliances and power will meet the demands for fuel in this country for some centuries to come by making coal and peat widely available and will relieve the strain in China, Korea and Japan to a large extent, it appears inevitable that within a comparatively few years farmers must, at least, grow the bulk of the stock which shall meet the world's rapidly-increasing demand for paper, and it seems clear, too, that there must come a large increase in the

manufacture of fabrics from the stems of plants along such lines as developed centuries ago in the Far East, where the practice still exists. How large an industrial factor this is to-day can be appreciated from the following figures giving the value of different articles manufactured in subsidiary occupations of the rural population of Japan during 1906.

Straw and wool braid.....	\$ 2,365,078
Bags, matting and package cases from rice-straw.....	6,000,000
Mats and matting materials..	4,215,038
Paper	6,861,114
Bamboo, willow and vine work	1,085,984

Total\$20,527,214

What a godsend such opportunities might be to the unemployed of our cities if they could be transplanted from their deplorable surroundings into the morally and physically pure atmosphere and unlimited sunshine of our open country and if they could be led to inherit something of the patience, the industry and the economy which are the salt of the yellow races!

We wish to correct two errors contained in Professor King's last article, published March 25th. The citation from Merrill should have read "no less than 27 pounds of nitric nitrogen (N₂O₅) per acre, 8.86 pounds of potash (K₂O), 1.07 pounds of phosphoric acid (P₂O₅) and 159 pounds of lime (CaO)." Toward the end of the article the statement "by the fermentation of the organic matter nitrates of potash and carbonates of magnesia and lime have been formed in the fuel ashes and in the soil," etc., should have read "by the fermentation of the organic matter nitrates have been formed from the potash, magnesia and lime carbonates in the fuel ashes and in the soil," etc. These errors represent deviations from Professor King's manuscript.

Practical Farm Notes

Improving Corn by Cross-Breeding

DURING the past five years I have had excellent success in improving corn by careful selection and cross-breeding. I began five years ago with Iowa Gold-Mine, a variety with long kernels, yellow and ripening early. After raising it two years, I was satisfied that it was run down from in-breeding. The ears were most of them small, there were many nubbins, the stalks were spindling and often barren of ears. So, three years ago, I mixed with my Iowa Gold-Mine seed one fifth as much of Reid's Yellow Dent, a variety which grows so big and rank that in this latitude (thirty-six miles southwest of Chicago) it will not ripen, if planted by itself. This gave me a yellow corn mixture which partook of the characteristics of both varieties, but had much larger ears than the Gold-Mine, which did get ripe and which added many loads, I believe, to my corn harvest.

The next season (not knowing at that time how to take the best care of seed-corn) I did not have a good stand. So I planted in with hoes, after the first planting was up, White Cap, a variety which ripens here if planted as late as the twelfth of June. This gave me a corn with the traits of all three of the above varieties—long kernels, big ears and early ripening. Last spring I got two other varieties of big yellow corn and mixed it, half and half, with the mixture I already had, and my corn crop was by far the biggest I ever had, and part of it was the biggest corn I ever saw in this latitude. One field of my corn, as near as I could measure by reckoning the number of rows sixty rods long to the acre and counting a double wagon-box rounding full as thirty bushels, yielded sixty-four bushels per acre. Another yielded seventy-two bushels per acre. The third piece I mostly cut for fodder and husked it daily through the winter. I cannot tell what the yield was, but it was big corn, and I feel safe in saying that my average yield per acre last season was over sixty bushels.

My first crop of corn, with the Iowa Gold-Mine seed, five years ago, was about thirty-two and a half bushels per acre. Of course, improvement of the land by deep plowing, manuring, wholesale clovering, etc., partly accounts for that gratifying increase in corn production. Better knowledge of farming and more strength for work (for I was an invalid minister when I began five years ago) also must be taken into account. But these things do not account for it all by a good deal. I had, this last season, whopping ears, sound and solid, thousands of them ten and a half inches long, and many twelve inches long, with twenty-two to twenty-six rows of long kernels on them. I picked out all nubbins in two forty-bushel loads, and there were not two bushel-baskets even full of nubbins.

I was so gratified, and also so sure of my theory that corn degenerates by in-breeding, that I reported my experiments to Prof. C. G. Hopkins of the Illinois Experiment Station. From him, under date of November 13, 1909, I quote: "Your results are in accord with ideas of some of the scientists concerning the beneficial effects of cross-breeding in corn. Corn is naturally a cross-fertilized plant, and in-breeding wherever it has been tried has proved detrimental." He then says that my experiments are in accord with what he himself has had in mind to do "for the last year or two," that all varieties of corn have been developed by more or less in-breeding, and that something of vitality and yielding qualities have been sacrificed to produce a distinct variety, true to some particular type. He also says that, as a result of experiments conducted some years ago at the Illinois Experiment Station, the conclusion was reached that if any two varieties of corn were mixed, half and half, the product in corn produced would be bigger corn than either parent variety. My own experience leads me to the same conclusion, for, though I was reared on a farm and have always kept an eye on it, I have never seen such a large growth of stalk, so large a proportion of big ears and so few nubbins in corn as resulted from this intermixture of big and early-ripening varieties. Such being the case, I believe we ought, every year or two, get more or less seed-corn from outside sources to mix with our own, just as we get roosters from the other flocks to improve our poultry.

I selected a number of the finest, most

perfectly formed ears, intending to make an exhibit at the corn show at Omaha. Later I learned that the artificial (as they seem to me) rules of judging corn, such as uniform color, uniform shape and type, would throw me out. What farmers want, however, and what the world needs for food for man and beast, is not corn which conforms to artificial rules, but big-yielding corn of good quality, regardless of uniformity. This, I am sure, can be best produced by cross-breeding.

WALTER E. EVANS.

There is no doubt that many corn breeders are sacrificing utility to fancy points. There is equally no doubt that the evil effect of in-breeding must be guarded against. Mr. Evans' experience goes to show that cross-breeding is a practical way to offset this. Is it the best way or the only way? We would like to hear from others of our readers who have had experience in this line.

EDITOR.

Queen's Golden Pop-Corn

WITH me this has proven the best of all the pop-corns. Growing large and tender stalks. The ears are large both in grain and cob. Its popping quality is excellent, there being no hard center, but large, tender and very palatable white kernels.

While the large stalk and the large yellow grains remind one of some of the yellow field-corns, yet one is happily disappointed when they pop and eat it.



A Corner of Mr. Van Aken's Field

This corn readily brings two dollars per bushel on the ear in the home market and is a profitable crop to grow, needing only the same amount of fertilization and cultivation as common field-corn.

SYLVANUS VAN AKEN.

Two Sides to the Wind-Break

IT HAS been interesting to read about all the benefits to be derived from planting a wind-break to the north of farm buildings, but so far no one has told of the damage that may be caused to those on the other side of the grove. Let me tell you how my neighbor fares in that position.

He owns the best farm in the township—a beauty, with an even slope, no spring holes or sinks, and deep rich soil, the very acme of fertility. The whole farm was like that a few years ago until his neighbor on the south side cleared his farm and left a strip of the old forest for a wind-break. All was fairly well so long as the old woods with its tall trees and no underbrush remained in the primeval condition: but

later a thick second growth filled in the gaps where the old trees fell till now, thirty years later, the growth is so thick a man cannot walk through it.

Our prevailing wind in this part of Maine is from the northwest and that drives the snow into that woods some winters twelve feet deep. As the strip is over twenty rods wide and about sixty rods long, it is easy to realize what an enormous amount of snow fills into that woods. Now the lay of the land is such that every drop of water from that huge snow-drift must drain down over the other man's farm, and as we never or seldom have any rain to melt the snow in the spring, it melts by the slow process of thawing by the sun. Some seasons this takes into the first week of June—it did last year. The owner could not sow these fields till the middle of June, and as a result the grain did not ripen last fall. He had to cut it partly green.

To make matters still worse, in wet seasons like last year those woods hold the water back so it takes several days longer for the land to dry up after a heavy rain. The Hon. Willis Moore to the contrary, forests do conserve moisture and dole it out slowly.

This wind-break does further damage by shading a strip of land some five or six rods wide so that it is no use to sow anything on it. It has been in grass for many years now, and the grass on a strip five rods wide, close to the woods, would not keep two sheep alive through the summer. Conditions are getting worse every year, as the undergrowth gets thicker and taller.

A man that plants or leaves a wind-break on his farm should first see to it that he does not ruin his neighbor with it.

V. T. LINDVAN.

Breeds His Own Corn

THERE is a good deal of discussion nowadays about corn, the selection of seed and the breeding of it. While all this has been going on, though I have sent out no seed-corn specials and offered no premium or made any noise about it, I have been working on my own hook, not on field-corn, but on that little article called pop-corn. I began with the ordinary White Rice, planted a little patch in my garden and for about ten years have selected the seed which was truest to my ideal type (for corn has points as well as chickens) until now I have a corn which is so different from that with which I started that it is almost like a new breed.

Instead of an ear with twelve or fourteen rows, it has sixteen or twenty and frequently thirty rows. That means one third more corn to the acre and its popping qualities cannot be excelled.

Raising pop-corn may, to some, seem a small business. No smaller than raising cherries or peaches, and where it is raised on a large scale by the hundreds of acres, it pays a good profit. Every farm should have its patch of pop-corn. Give it to the boys to take care of, and besides laying up lots of fun for the winter evenings, they may get out of it quite a little pocket-money, for it has a ready sale at two cents or more a pound, in almost any town.

E. J. SMITH.

The advisability of each farmer breeding his own strain of corn cannot be questioned, whether he intends breeding up a type of his own or not. Corn likes the soil of its ancestors. Moving harms it, for a while at least.

EDITOR.

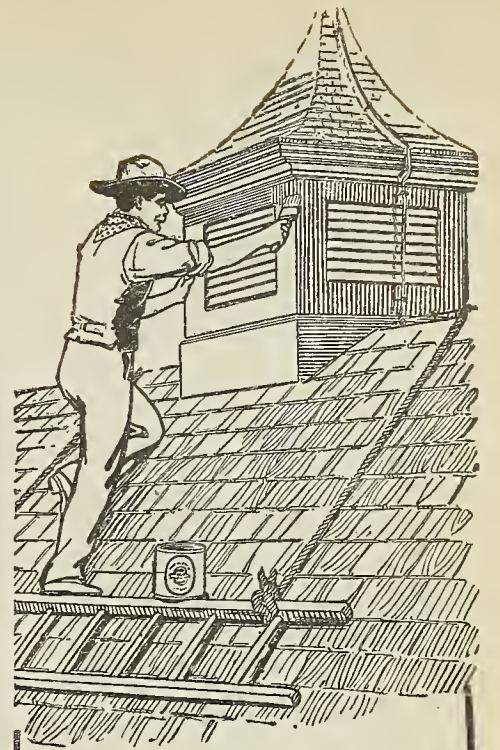

Special Paint for Barns and Roofs

ACME QUALITY, of course. Made expressly for painting barns, roofs and out-buildings. Preserves the wood, looks well, is economical in first cost and holds its surface and color for years. Yet Acme Quality Barn and Roof Paint is only one of the many

ACME QUALITY Paints and Finishes

Among them are special kinds for carriages, wagons, farm implements, and every other purpose, indoors and out. Write for a copy of the

Acme Quality Guide Book

Tells just which paint, enamel, stain or varnish to use; how much to use and how it should be applied. Illustrated in color.

Your dealer probably has Acme Quality Paints and Finishes.

If he cannot supply you, write to

ACME WHITE LEAD AND COLOR WORKS

Dept. X Detroit, Mich.



WELL DRILLING Machines

Over 70 sizes and styles, for drilling either deep or shallow wells in any kind of soil or rock. Mounted on wheels or on sills. With engines or horse powers. Strong, simple and durable. Any mechanic can operate them easily. Send for catalog.

WILLIAMS BROS., Ithaca, N. Y.

MONTRoss METAL SHINGLES
Last a lifetime. Nothing better sold. Used over 21 years. Fireproof, Ornamental, Inexpensive. Catalog Free. Montross Co., Camden, N. J.



H. C. PHELPS, Manufacturer of Split Hickory Vehicles

FREE To You—Let Me Pay Postage On My Big Book To Your Home and Save You \$26.50

Just send me your name and address on a postal. That brings you my book and prices. Then compare values—and buy where you get the biggest bargain. We are actual manufacturers and sell direct to you. You save all middle profits. I save buggy buyers thousands of dollars each year. Let me save you \$26.50 to \$40 this year on the buggy you want. Choose from my book of 125 styles. Try any Split Hickory Vehicle on your own roads for 30 days. If you keep it, I'll stand back of it with my 2 years' guarantee. Get my book first—I'll pay the postage.

See My 1910 Split Hickory Auto-Seat Special

This is my 1910 leader—my best bargain for you. I save you at least \$26.50 on it. It is the most dashing, stylish buggy made. Has 125 special features—laminated auto-seats; easy springs; lots of leg-room; extra long waterproof top; Sheldon springs—and everything else needed for style, service and satisfaction. See it in my book—in full colors. It's just a hint of what I save you on any vehicle you buy from me. Write that postal now—send it by next mail. Don't buy a buggy till you get my color-illustrated book.

Ohio Carriage Mfg. Company, Station 23, Columbus, Ohio

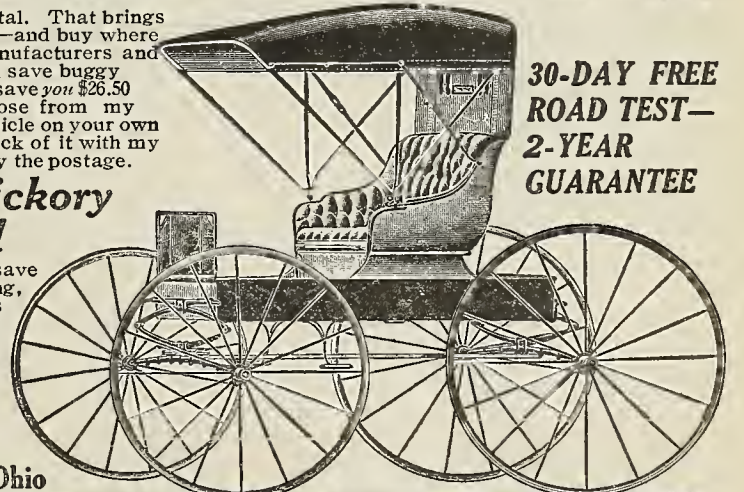

30-DAY FREE ROAD TEST—2-YEAR GUARANTEE

The American Flag

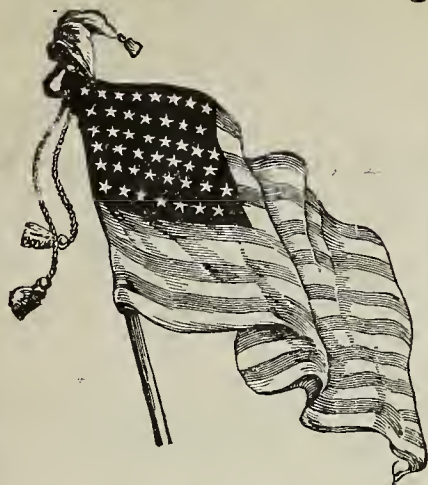

FOR decorating rooms, porches, churches or schools, nothing is so fine or beautiful as The Flag. Decoration Day and the Fourth of July are near. You will want this flag the worst way, and find use for it many, many times.

This beautiful flag is 2 1/2 feet wide and four feet long. It is guaranteed fast colors. The red and white stripes are 2 1/2 inches wide and the stars are two inches wide. It has a white tape edge with brass eyelets set into the corner, for fastening to a rope on a flag pole.

How to Get One

We will send you this American Flag without cost to you if you will send us only three eight-month subscriptions to Farm and Fireside at 25 cents each. Your own can be one and you can easily get two of your neighbors to take Farm and Fireside. Then send us the three subscriptions and you will have the flag by return mail. Address

FARM AND FIRESIDE, Springfield, O.

Fruit-Growing

The Battle Against Fungi

A FRIEND of mine, a man who has always made money in his own line of business, took up some few years ago the growing of fruit in a commercial way and has so far made a failure of it. Talking with him recently, we discussed the subject of fungi and fungicides. He announced that his plan of control consisted in wrappings of burlap around the tree-trunks to keep the fungi from crawling up the trees. From present indications, if his orchards continue to suffer from this same lack of information, what is left of them can soon be purchased at a bargain price by some one who knows that fungi are not 'crawling insects, but are analogous to the germs that attack animals. They produce real tree or fruit diseases that are best treated by methods which prevent their ever getting started.

The number of these different fungi are legion, and in different sections different preventive measures are necessary. Every orchardist who places any value on his trees should find out from his state experiment station what to guard against in his locality and how to do it; and a dollar sent to the secretary of the state horticultural society for membership and a copy of the society report will show what practical fruit-growers of the state have to say, not only about fungus, but other fruit-growing problems.

The commercial spray-material manufacturers, the spray-pump people and the big seed-houses all publish spray calendars. Every man with one or more fruit-trees, berry-bushes or grape-vines ought to have half a dozen of the different spray calendars at hand at all times for ready reference whenever spraying topics are under discussion.

In general, where careful winter spraying is done against the San Jose scale, the crevices of the bark and the wooly tips of the spurs are cleaned of fungus spores which otherwise would grow into troublesome fungi on the arrival of favorable weather. So also clean cultural methods, careful drainage to prevent stagnant water, proper fertilization, pruning, codling-moth spraying and all other orchard practices influence directly and indirectly the growth of fungi. These remedial measures against fungus diseases are so interrelated with all those other problems that sometimes the definite danger from fungus is overlooked.

Because simple rules for spraying against fungus are hard to give, except as a part of other rules for spraying against San Jose scale and codling-moth, etc., the necessity is, therefore, all the more urgent for every fruit-grower to make a careful personal study of the fungus diseases which his state officials and brother fruit-growers advise him are liable to attack his orchards and garden.

The spores of some forms of fungi carry over from one season to another in mummied fruit. Therefore, as one rule of action, pick every fruit. Never leave mummies on the trees as possible sources of trouble another season. The blight which so noticeably and injuriously attacks pear-trees in many sections should be cut out in the late autumn and the wounds disinfected with bichlorid of mercury, or corrosive sublimate. The black knot of plum and cherry trees ought, also, to be cut out by careful aseptic tree surgery. Peaches are sometimes subject to a most destructive disease called "yellows." Neither surgery nor spraying seems to control it. Immediate and prompt destruction of the infested tree is absolutely necessary. Any suspicion of peach yellows should be reported to the state officials with an urgent appeal: "Come over into Macedonia and help us."

Fungi are vegetable growths, not to be warded off or killed after development by poisons like Paris green and arsenate of lead. Sulphur in combination with lime; copper in combination with lime (as Bordeaux), and some of the special coal-tar products are the common fungicides. Spraying operations against fungus diseases must include one of these fungicides.

One interesting exception to the general rule is the practice now coming into use of controlling the brown rot of peaches by killing with arsenate of lead the curculio insect and thus preventing the new-moon-shaped punctures in the skin of the peach made by that insect, without which the brown rot spores cannot enter the pulp of the fruit and begin their growth. But if the right kind of arsenate of lead is not used at the

right time the injury to the peaches by the burning of the soluble arsenic in the spray may be worse than the brown rot. The experiment station at Mountain Grove, Missouri, has published a most interesting bulletin on this subject.

Bordeaux mixture still remains the standard fungicide for apples to use in combination with arsenate of lead at the spraying done just after the blossoms fall, again for ten days to two weeks later, and again ten days or two weeks still later. There may be special conditions due to excessive rain or other causes which will require additional fungicidal sprayings. When such arise, the competent grower meets them. Even though there be no fruit to save he realizes that the lungs of his trees, the leaves, must be kept in breathing condition, or the tree will not have vitality to set the fruit buds which another year may develop into fruit.

With some varieties of apples, like Ben Davis, Bordeaux cannot safely be used just after the blossoms fall because of the russetting and disfigurement of the fruit which almost surely results. For best results from the use of Bordeaux every apple-orchardist needs to study the varieties and treat each according to the method to which it best responds.

Prof. W. M. Scott, Department of Agriculture, Washington, has published bulletins about the use of lime-sulphur preparations as summer fungicide on apple-trees, as well as peach and plum, in place of Bordeaux. Many large growers are adopting his suggestions, hoping to avoid the troubles which have sometimes resulted from the use of Bordeaux—troubles mostly due, however, in my judgment, to improper preparation or lack of individual care in treating different varieties of apples. All fruit-growers should, however, study Professor Scott's reports and keep in touch with the developments regarding lime-sulphur as a summer fungicide. Peach-growers in particular who have been afraid to use other fungicides on peaches in foliage seem to be successfully using the self-boiled lime-sulphur described in these bulletins.

But fungicides should be of interest not alone to the fruit-grower. When we realize that the lack of "copper plating" (with Bordeaux) at the right time on the potato-vines often cuts down the yield of tubers from fifty to one hundred per cent, and that grapes, berries, tomatoes and most other intensive crops are often subject to fungus diseases which, when not checked, destroy the larger part of the yield. It occurs to us that Mr. Hill and the other prophets who fear natural starvation ought not to overlook "fungicides" in the warnings they send out. N. T. FRAME.



Shortly after his election to the Presidency Theodore Roosevelt visited Oakland. In a letter written in Oakland at that time to a friend in Washington, he said: "Oakland is a city, just across the bay from San Francisco, where one finds the soft air of Italy and the beauty of English villages combined with a spirit of Western Progress and commercial advantages which will some day as far as I am able to judge from my limited investigations, make it the greatest railroad terminal on the Pacific Coast."

Oakland is a bustling, fast growing American city with thousands of investment opportunities and 300,000 population—an ideal place in which to live and enjoy life to the utmost, whether at work or at play.

Write for free souvenir book of views taken in midwinter. Address Dept. X, Oakland Chamber of Commerce.

OAKLAND California

The City of Opportunity

BROWN FENCE

For Rabbits, Chickens, Hogs, Sheep, Horses, Cattle. 160 styles. Big heavy No. 9 galvanized Coiled Spring rust proof wires. Will defy stock, wind and weather. Free sample & cat'g. 15 to 35c per rod. We pay freight

The Brown Fence & Wire Co., DEPT. 21 W Cleveland, O.

Post-Cards Without Cost

We will send you the complete set of the famous 24 of Roosevelt in Africa post-cards if you will send us 25 cents for one 8-month trial subscription to FARM AND FIRESIDE. The trial subscription must be a new subscription. Send the 25 cents for the subscription in coin or stamps.

FARM AND FIRESIDE Springfield, Ohio

Goin' Fishing?



Then You Will Want This Fine Three-Piece Bamboo Rod, Complete With Reel, Line, Sinkers, Float and Six Hooks

We have selected this fine, three-piece bamboo rod, click reel, oil silk line, sinkers, float and assortment of hooks, as

A Gift to You

We particularly want you to have this bait-casting rod, and, of course, you'll want the other supplies, especially when we explain that the complete outfit will be sent without one cent of expense to you.

For particulars how to obtain this outfit, write at once to FARM AND FIRESIDE SPRINGFIELD, OHIO

I Say
Genuine Joy
Genuine Appetite
Genuine Health
and therefore
Genuine Complexion
All come from
eating the
GENUINE



Kellogg's TOASTED CORN FLAKES

The standard set by Kellogg's is unequalled in any other flakes made from corn. The best white corn alone is used. Thus its crispy flavor is unequalled — its wholesomeness unquestioned.

The good effect of its continued use, upon the health, is evidenced by the clear complexion of its best patrons. But you must get the right kind.

None Genuine without this Signature

W. K. Kellogg



Judge by a Roof—Not by a Two-Inch Sample



PAROID ROOFING

is manufactured by a firm that has been in one line of business since 1795. It lasts because it is made *right*, from start to finish. Let us show you a roof that has stood exposure; see how it looks. Let us give you the owner's name; hear what he has to say.

Our Offer: When you see Paroid on your building, if you are not satisfied, tell us and we will send you a check for the full cost of the roofing and the cost of laying it. Back of it all, if any Bird Neponset Product ever fails because of defective manufacture, we will replace it. If a broader guarantee than this could be made we would make it.

Are You Building or Repairing?
Our Building Counsel Department is at your disposal. Give us full particulars and we will gladly give you, free, expert advice on all roofing and water-proofing questions.

If your dealer does not carry Bird Neponset Products, write us.

F. W. BIRD & SON
Main Mills and General Offices:
48 Neponset St., East Walpole, Mass.
New York Chicago Washington Portland, Ore. San Francisco
Canadian Mills and Offices:
Hamilton, Ont. Winnipeg Montreal St. John

Live Stock and Dairy

Her Ladyship, the Cow

I WONDER if we always remember how quiet and placid a creature a good, properly-raised cow is? True if the calf has along with its milk a surplus of dry matter, in the shape of kicks, blows and cuss-words, it develops a timidity that will probably go with it through life. Like the human mind, the baby calf "is wax to receive and marble to retain impressions." If the calf grows up in an environment of bad usage, is partly fed and moved from place to place in the barn with dung-fork persuasion, and is taken to and chased from pasture by a worthless, snarling, barking dog, it cannot have implanted in its nervous structure that reposeful dignity and de-liberation so becoming the well-bred, finely-organized lady of the dairy. But lead the calf, the heifer, the cow in green pastures and by still waters, have her ways ways of pleasantness and all her paths peace; let her always feel that you are a kind, generous, careful gentleman, her master and provident protector, and she and her children will rise up to make you blessed with the rich churnable milk of human kindness.

The cow is a thoroughly domestic animal. She loves peace and quiet. Her neck is not fitted to the yoke, her shoulder is not built to press against heavy loads, she is not an animal of speed, constructed to withstand great tests of physical endurance. She is not of the line of the survival of the fittest, but an evolution of the refinement of the finest. She is not ordained to be driven, but to be coaxed and led—she is feminine.

The more comfortable, the more at ease, this cow can be kept, the greater her production, with the minimum of expenditure of vital forces; hence quiet stands for profit in the cow. We do not know exactly how the cow from the resources of her blood elaborates her milk, but we are led to believe that it is an operation of her nervous functions, since we find the heavily-producing dairy cow one of highly nervous organization. Her comfort and quiet contribute to the pro-

ductive operation of her functions, while discomfort and excitement divert their tendencies and arrest secretion and production. The excited, abused or neglected cow is not the normal cow, and it is the normal cow that gives a uniform quantity and quality of milk.

Among all our domestic animals none better repays careful contemplation of her characteristics and habits than the contemplative cow. Some schools make much of the "humanities" in their schemes of intellectual enlargement. This good cow is a living illustration of the text. She is patient, slow to anger, nor wears in well doing, she responds readily to kindness and is long suffering under abuse. She becomes a mother and provides for her offspring, far in excess of its requirements; she furnishes complete nourishment for the new-born babe, the invalid and the adult of our superior race. She takes the crude grains, grasses and fodders of the field, and by her marvelous alchemy—never equaled by the cunning of man—transmutes them into this wonderful, universal food. She asks not distinction or reward—only justice. She probably weighs eight hundred pounds and in a year, in addition to producing a calf, will give six to eight thousand pounds of milk that may be churned into three hundred to four hundred pounds of butter.

She loves much, serves much and dedicates all the good of her life to the uses of mankind. Let us render unto her the things she deserves.

W. F. McSPARRAN.

GAL-VANITE
TRIPLE ASPHALT COATED MICA PLATED
ROOFING
A Healthy Roof

When your stomach is right, you don't know you've got one. That's just the way with Gal-Va-Nite Roof,—you don't know it's there, because it never bothers you.

It doesn't require any medicine in the way of paint or patches, or you won't have any doctor bills for leaks or rotten places.

Gal-Va-Nite is made to *stay* right; the oils in it are kept there by a coating of mica on each side. Mica resists the weather better than other minerals, and is much lighter than gravel or crushed stone.

No roofing is easier to put on. Every roll contains cement, nails, and careful instructions. Get your hammer and jack-knife and you can quickly do the job.

Use Gal-Va-Nite—do the job right. Ask for free samples and booklet.

Union Roofing & Mfg. Co.
Main Offices and Factory:
1141 to 1157 E. 7th Street,
ST. PAUL, MINNESOTA



Try My Stanchions Stalls, Feed and Litter Carriers at My Risk

W. D. James SANITARY BARN EQUIPMENT MAN

I guarantee satisfaction with every part of my equipment, whether you buy one stall or a complete barn equipment.

JAMES SANITARY STALLS, ALIGNING STANCHIONS, FEED AND LITTER CARRIERS and other conveniences are endorsed by the best business dairymen for convenience, sanitation and economy. New improvements place JAMES goods more than ever beyond comparison with others. Write for prices and full particulars.

W. D. JAMES, Mgr., KENT MFG. CO., 160 Cane St., Ft. Atkinson, Wis.



An Udder Trouble

A SUBSCRIBER at Pearl, Michigan, has a cow one of whose teats swells occasionally. At these times no milk can be gotten unless the teat is opened with a straw, and the milk is stringy.

It is never a wise plan to use straws or the like to insert in the opening of a cow's teat. You are liable to insert germs that will cause endless trouble.

It is impossible, even were I to see the cow, to tell you whether or not she is tubercular. The only way is to apply the tuberculin test. Some cows that look healthy and are healthy in every other way are tubercular. For instance, many of our prize-winning animals at fat stock shows, when killed, are found to be tubercular. On the other hand, cows are often poor and emaciated from other causes, but perfectly free from tuberculosis. The test is very simple and is the quickest and most efficient; in fact, the only way to determine whether or not a cow has this disease.

Tuberculosis may or may not be the cause of the swelling of the teats and the stringy milk. I have never known of a cow thus affected. It is possible to insert teat plugs which your druggist can secure for you with directions for using them. These plugs are metal and can be thoroughly disinfected with a solution of carbolic acid or some other disinfectant before inserting them in the opening of the teat. They answer the same purpose as straws and there is no danger of infecting and ruining the udder.

I take it from your letter that as a rule the cow milks all right and only occasionally there is any trouble with her. Were her teats always in this condition it would then likely be due to an infection, but if the cow is giving good milk without trouble most of the time that could hardly be the case.

H. G. V. P.

Guaranteed Ensilage Cutter BLIZZARD

Sold on merit backed by 33 years' success. Proved strongest, most durable, smoothest running. Cuts green or dry feed and elevates any height. Knives adjustable at any time. Perfected construction throughout. Mounted or unmounted. Ask for free book, "Why Silage Pays."

Write for New Catalogue Free

Jos. Dick Mfg. Co.
1444 W. Tuscarawas St.
Canton, Ohio



Get out of the rut

Give your buildings the benefit of progress—same as you give the farm itself. Cover every building on the farm with Genasco Ready Roofing—the economical roofing that protects and lasts.

Genasco Ready Roofing

is made of Trinidad Lake asphalt—Nature's everlasting waterproofer. It prevents cracks, breaks, and leaks, and does away with damage and repairs. Easily applied without experienced help.

The Kant-leak Kleet does away entirely with cement and large-headed nails. Keeps seams absolutely watertight. Saves time in laying. Makes a beautiful finish. Ask for Genasco rolls with the Kleet packed in them.

Ask your dealer for Genasco. Mineral or smooth surface. Be sure you see the hemisphere trade mark. A written guarantee, if you want it. Gold medal (highest award) Seattle, 1909. Write for samples and the Good Roof Guide Book.

THE BARBER ASPHALT PAVING COMPANY
Largest producers of asphalt, and largest manufacturers of ready roofing in the world.

PHILADELPHIA San Francisco Chicago
New York

Cross-section, Genasco Stone-surface Ready-Roofing
Gravel
Trinidad Lake Asphalt
Asphalt-saturated Wool Felt
Trinidad Lake Asphalt
Asphalt-saturated Wool Felt

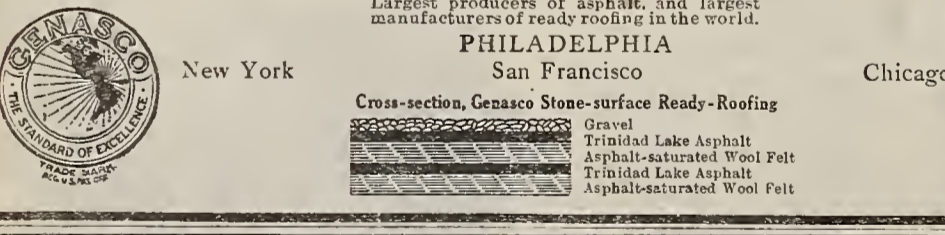

Biggest Hay Press Profits
Made With **DAIN Presses**

Dain Pull Power or Belt Power Presses make largest number of perfect bales each day with fewer hands, lightest work, smallest repair expense. Simple steel construction. No clumsy step-over pitman, no troublesome toggle joints. Patented tucker makes smooth ended bales that pack closely and sell quickest. Don't buy a press before you get some very important information from us. Write today.

DAIN MFG. CO. 860 Vine St. Ottumwa, Ia.



THE PROOF OF THE HAY PRESS

is its capacity and earning power. Spencer Hay Press Catalogs make great and definite claims. Every claim is proven by the press in action or no sale. Contract protects you. It covers every claim by positive figures. The nature of the contract itself should convince you of the absolute superiority of the press. Send for our new catalog D. Please mention this paper when you write.

J. A. SPENCER
Dwight, Ill.

Write us now.



SAVE YOUR HARNESS

It can be made to look like new, made softer and easier on horses, made to wear longer, by occasionally using the old reliable harness preparations:

FRANK MILLER'S HARNESS SOAP HARNESS OIL HARNESS DRESSING

For nearly four generations the name "Frank Miller" has stood for the very best in harness oils, dressings, etc. The goods have often been imitated, but never equalled. Occasionally a dealer will offer a substitute because his profit is larger, but the majority will recommend the best—Frank Miller's.

"BLACK BEAUTY" FREE

We want you to have a copy of this wonderfully interesting book, the "Cute Tom's Cabins" of the horse. Probably no book has ever received such universal and unanimous praise from both the secular and religious press.

Write us to-day, mentioning this paper, and enclose 6 cents in postage, to cover mailing expense, and we'll promptly mail you a copy of "BLACK BEAUTY" free of charge. Don't delay. Supply limited.

THE FRANK MILLER CO.
349-351 WEST 26TH STREET ESTABLISHED 1838 NEW YORK CITY



A Tennessee "Mule-Day"

THE March 10th issue of FARM AND FIRESIDE contained a note to the effect that more than one thousand mules had been on the market at Columbia, Tennessee, in January. Upon the publication of that, a letter from Columbia brought us the following additional information:

"Instead of one thousand for the month, there were more than that number handled here in a single day (the first Monday in January). The manager of the Columbia stock-yards stated that one thousand was a conservative figure." As for the rest of the month, our correspondent says: "I know of several heavy dealers in the county and town not included in this list. I do not pretend to say how many mules were handled here in January, but certainly one thousand or more were handled on the streets that one day. With the exception of St. Louis, Kansas City and Atlanta, Georgia, we claim to be the biggest mule market in the world. I saw six hundred and twenty-five dollars offered and refused for one pair of mules"

JIG-SAW PUZZLES

Would you like to get one of the new Jig-Saw Puzzles that have made such a tremendous hit in popularity? These Jig-Saw Puzzles are extremely popular. Parties are given where every one plays with Jig-Saw Puzzles, trying to put them together. They have made a big hit entertaining folks and make lots of fun.

Our Offer

We will send you a fine Jig-Saw Puzzle, postage prepaid, if you will send us 10 cents in coin or stamps for a three months' trial subscription to FARM AND FIRESIDE. The trial subscription must be for some one who does not now take FARM AND FIRESIDE.

Address FARM AND FIRESIDE, Springfield, Ohio

Make With An American Money SAW MILL

Lumber is high. A car load or two pays for an American Mill. Supply your needs and your neighbors'. No experience needed. Haul mill to timber if desired. All Sizes—All Prices. The Variable Friction Feed, Combined Ratchet Set Works and Quick Receptor means most work with least power.

For a Catalogue lists all kinds of wood working machinery. Ask for it.

American Saw Mill Machinery Co.
130 Hope St.
Hackettstown, N. J.
1576 Terminal Building
New York



LIGHTNING HAY PRESSES

Tested for over 25 years. Made in many styles, Horse Power, Belt Power and Self-feed Attachment. Simple and Durable with Greatest Capacity. They make a Profitable Investment.

We can suit you. Write for Catalog and Prices.

KANSAS CITY HAY PRESS CO. 124 Mill St., Kansas City, Mo.



Choose Your Paint With Care

Labor represents three-fourths the cost of every painting job. Your painter will charge as much to apply cheap, shoddy, paint as the best white lead. Therefore, you should choose your paint with care.

To be certain of durable and economical paint, request your painter to use

CARTER

Strictly Pure

White Lead

"The Lead With the Spread"

It is the best of all white leads—the purest, whitest, finest, most economical and durable.

Carter Lead never cracks or scales—no expensive burning or scraping off the old paint when Carter is used.

Send today for our beautiful and instructive book, "Pure Paint," with set of modern color schemes. It tells how to test paint for purity, how to choose a harmonious color scheme, and gives many other helpful suggestions. Sent free on request. (18)



"To Be Sure It's Pure, Look for CARTER on the Keg."

Carter White Lead Co.
12051 So. Peoria St.,
Chicago, Ill.
Factories: Chicago—Omaha

Holds World's Record The New 1910 Model U. S. SEPARATOR

is emphatically the BEST and the only one for YOU to buy.

1. It skims the cleanest.
2. It's built the strongest.
3. It's the easiest cleaned.
4. It's the most convenient.
5. It requires least power.

The U. S. defeated all other Separators at Seattle on these five essential points and

Won Grand Prize

Vermont Farm Machine Co.
Bellows Falls, Vt., U. S. A.



Send for Cat. 69
It tells you all.

Boys!

Read This Offer

A FINE FIELDER'S GLOVE, well made and durable and of latest design. This glove is substantially fashioned and is all ready for use. Requires no breaking in and is well padded.

A STRONG MASK, made of heavy, bright steel wire, well padded and finished in the approved manner. An excellent protection to the face.

A CATCHER'S MITT of the latest model, well padded and serviceable. It is the same in design as those used in the big leagues and will wear well.

THE OFFICIAL BASE-BALL GUIDE. This guide is brimful of base ball information. All the rules, records and pictures of the best known players. Everything that you want to know about base-ball.

A Gift To You

For full particulars, explaining how you can secure any or all of these fine Base-ball supplies, write at once to

FARM AND FIRESIDE
Springfield, Ohio

Your Humble Servant, the Horse

IN SELECTING horses for general farm work the chief points to consider are size, strength, quickness and disposition. The highly nervous horse is out of place on a farm where he is compelled to do heavy work. One of the first essentials of a good farm horse is that he be a good, prompt walker. Much of his value will depend on this gait. I am not in favor of training colts and putting them into hard work until they have reached a fair maturity, yet we make a mistake if we allow them to reach maturity without being harnessed and trained to perform light work and to walk up promptly. If the colt is allowed to grow up into a large awkward animal before he is given his first lessons, he is sure to be an ill-gaited, slow walker. I believe that there are more slow walkers caused by methods of training than by inherited qualities.

Farm teams should not be highly pampered, but given good care and a liberal amount of substantial foods to sustain them in a vigorous and sprightly condition. A team that is in low flesh will not accomplish one half the work that one would that is well cared for.

The work teams should be fed early in the morning so that they will have time to eat plenty of food before they begin work. The horse should never be put at heavy work immediately after a hearty meal.

The harness, and particularly the collars, should be accurately adjusted to the horse. If the collar is too tight or too loose, it galls the horse and interferes with his respiration. It gives the teams great comfort if the harness is removed during the noon-hour while they are feeding. If a team is allowed a brief rest after they are fed, they will be fit for better work than if they are started as soon as they finish eating.

A warm and sweaty team should never be placed in a cold stable at once or kept standing in the cold or in currents of air. It is safer to move them about slowly until heat and pulsation are abated. After this give them a good grooming and dry them off. The team that has been out in a cold rain should not be left to dry off. Rub them with a brush or comb and follow this up with wisps of hay or straw and then blanket them for a few hours. Never turn a horse in the pasture when the weather is cool and his hair and skin are moist.

When the team is wet from work in the winter, they should be stabled at noon and carefully blanketed. We can afford to go out of our way to observe these precautions. It is cruel and dangerous to allow horses to become chilled while feeding and possibly contract colds.

One other thing I wish to protest against is dosing and doping of work teams. More good horses have been ruined by doping them with these so-called medicated foods, overfeeding and idleness than by hard work. The work team should have a little exercise every day and not stand day after day in the stable and then be taken out and made to do a heavy day's work.

W. MILTON KELLY.

Good Feed, Good Work

PEOPLE come to me telling of feeding a horse two quarts of shelled corn and one of bran or oats at a feed (in winter) or six and eight ears of corn. To my notion this is entirely too much, as most of these overfed horses are always in poor condition. My horse weighs about eleven hundred pounds and gets one quart of shelled corn and one quart of wheat-bran, mixed (often scalded and cooled), at each feed, or a quart of oats instead of corn. This is supplemented with half a bundle of fodder or a forkful of hay for roughage, three times per day.

When hard at work, the quota of feed is increased about two quarts per day, and during the long summer days the horse is watered three or four times in the day. It does not matter so much what the feed is, so long as it is given at a regular hour, even when on the road. Irregular or hurried meals give any man dyspepsia in a little time, and I hold that they will do the same for a horse.

Few horsemen pay enough attention to the teeth of the old horses, and then wonder why they look out of condition. It pays to let an experienced veterinarian examine and put the teeth in condition at least every year. I paid a man two dollars to file the teeth of a horse twenty-two years old, but it added years to his usefulness.

No horse can thrive on musty bran, oats or corn. Insist on getting pure, clean feeds. You can tell them by tasting a sample. This is an old miller's method. Half the horses that take sick or die, do so because of hasty or injudicious feeding. Hasty mistakes are costly.

CLIFFORD E. DAVIS.

The best gall cure is common sense in keeping the harness properly adjusted.

Amatite ROOFING

A Frank Statement

HOW many manufacturers of ready roofing will tell you frankly how their goods are made?

Mighty few.

They will talk about "secret formulas," "special waterproofing compounds," etc.—all nonsense.

They don't tell you what the goods are made of because they don't dare.

From the start we have never hesitated to tell the buying public just what Amatite is made of and just what it will do.

How Amatite is Made

Amatite is made of two layers of Coal Tar Pitch—the greatest waterproofing material known.

Alternating with these two layers of pitch are two layers of coal-tar-saturated wool felt to give it tensile strength.

On top of these four layers is a real mineral surface—five layers of protection.

The mineral surface is permanent, fireproof, and absolutely requires no painting.

It Needs No Painting

Roofings that require painting are a worry and an expense. Every year or two you have to climb up and give them a coating with some special compound sold by the manufacturers, or you are pretty sure to have a leaky roof.

Amatite is Making Good

We are constantly receiving letters from customers telling us how satisfied they are with Amatite—how much better it is than the old-fashioned roofing.

Year after year, in all weather, Amatite will give perfect service without any painting or attention of any kind.

Surely this is the kind of service that wins and keeps customers.

Free Sample

Before you go to your dealer and buy a roofing, we should be very glad to send you a sample, so that you can see for yourself just what we are talking about—what a solid, substantial, reliable roofing we are offering to the public.

Something Back of It

Remember, in this connection, that Amatite is made by the largest manufacturers of roofing materials in the world, and that when you buy this roofing there is something behind it. We stand back of every roll. We know we are offering the best and the most economical ready roofing on the market.

For the sample and booklet, address our nearest office.

BARRETT MANUFACTURING CO.

New York Chicago Philadelphia
Boston Cleveland St. Louis
Minneapolis Pittsburg Cincinnati
New Orleans Kansas City London, Eng.



Amatite on Lumber Sheds of B. F. Harris & Sons, Brushton, N. Y.

We'll make that old-time watch a modern timekeeper

The sentimental as well as the practical value of a keepsake watch is increased by having it put in condition to carry as a timekeeper. It then becomes a more constant remembrance and more closely associated with its present owner.

Our factory has many facilities for making, at very moderate cost, changes in old watches to fit them for service as convenient modern timekeepers. Cases can be changed to hold present day movements, and an accurate, serviceable watch made of an heirloom of any age or make, foreign or domestic. Such changes generally do not affect the original individuality of the watch to any appreciable extent.

Write us description of watch and we will answer with a personal letter giving details.

ELGIN NATIONAL WATCH COMPANY
ELGIN, ILLINOIS

The Most Sacred Spot

In any community is the last resting place of loved ones, and if only as a mark of respect it should be fittingly kept and made proof against desecration.

Cyclone Cemetery Fence and Gates

are designed to harmonize with and beautify the old burying grounds. They last for years, are stock proof and much cheaper than wooden fences. Write for our fine, free illustrated catalogue. Address
CYCLONE FENCE CO., Dept. 109, Waukegan, Illinois.

WHITMAN'S HAY PRESS

New Model Steel Beauty

40 Years Standard of the World

FINEST IN AMERICA
Yet costs no more than the ordinary kind

Also Power Balers

Let us prove that our New Model is the Strongest, Most Durable, Most Economical and Simplest Hay Press in the World—does the best work—has greatest capacity—saves time, labor and trouble—contains exclusive feature found in no other press—with or without self-feed, pull back and hopper condenser—fully guaranteed—we also make largest line of Balers in the world—write for illustrated catalogue.

THE WHITMAN AGRICULTURAL COMPANY, 6914 S. Broadway, St. Louis, Mo.

THEY THINK You Don't Know

Any one who thinks he can hide from you the fact that disk-filled or other common cream separators are complicated and hardest to clean, must think you never use your eyes. Any one who tries to convince you that disks or other contraptions are necessary in a modern separator must think you know nothing of facts.

Sharples Dairy Tubular Cream Separators

have neither disks nor other contraptions, yet produce at least twice the skimming force, skim at least twice as clean, wash many times easier, and wear a good many years longer than common, complicated separators.

That is why farmers all over the world call Tubulars "The World's Best," and it explains why Tubular sales exceed most, if not all, others combined and why Tubulars probably replace more common separators than any one maker of such machines sells. World's biggest separator works. Branch factories in Canada and Germany. Write for Catalogue No. 112

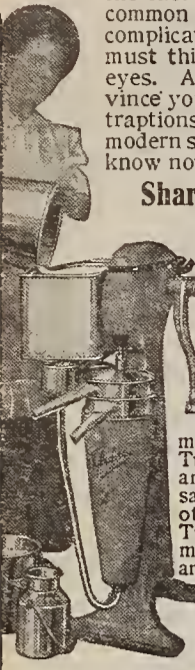

Sharples Dairy Tubular. The World's Best. 30 Yrs

THE SHARPLES SEPARATOR CO. WEST CHESTER, PA. Chicago, Ill., San Francisco, Cal., Portland, Ore., Toronto, Can., Winnipeg, Can.

THE BIGGEST FREE VEHICLE AND HARNESS BOOK

Before you buy compare Murray's splendid offers with others. Send for our new

1910 Style Book of Vehicles and Harness

See for yourself how you can save money—get better values on any kind of vehicle or harness you want. Murray sells direct—gives four weeks trial—insures safe delivery—two years guarantee. We want every farmer to get this Free Book. Send for it today.

The Wilber H. Murray Mfg. Co. 322-328 E. 5th St., Cincinnati, Ohio

GET THIS BOOK AND COMPARE VALUES WITH ALL OTHERS BEFORE YOU BUY ANY KIND OF VEHICLE

TUGS CAN'T JERK OR WORK LOOSE

You are doubly protected by the Fernald Double Trace Holder. Tugs are always held tight by this patented grip. Cheapest excellent insurance on earth. You can attach it in five minutes. Mud or snow can't clog it. Costs so little you can't afford to be without it. Best dealers everywhere.

Ask your hardware or harness dealer or write us. FERNALD MFG. CO., North East, Pa.

Elkhart Buggies

are the best made, best grade and easiest riding buggies on earth for the money. Save \$30

FOR THIRTY-SEVEN YEARS we have been selling direct and are The Largest Manufacturers in the World

selling to the consumer exclusively. We ship for examination and approval, guaranteeing safe delivery, and also to save you money. If you are not satisfied as to style, quality and price you are nothing out.

May We Send You Our Large Catalogue? Elkhart Carriage & Harness Mfg. Co. Elkhart, Indiana



\$15.95 AND UPWARD

THIS OFFER IS NO CATCH. It is a solid, fair and square proposition to furnish a brand new, well made and well finished cream separator complete, subject to a long trial and fully guaranteed, for \$15.95. It is different from anything that has ever before been offered. Skims 1 quart of milk a minute, hot or cold, makes thick thin cream and does it just as well as any higher priced machine. Any boy or girl can run it sitting down. The crank is only 5 inches long. Just think of that! The bowl is a sanitary marvel; easily cleaned and embodies all our latest improvements. Gears run in anti-friction bearings and thoroughly protected. Before you decide on a cream separator of any capacity whatever, obtain our \$15.95 proposition.



AMERICAN SEPARATOR CO., BOX 1058, BAINBRIDGE, N.Y.

Live Stock and Dairy

When Should Heifers Freshen?

There is a great difference of opinion relative to how old a heifer should be before freshening with her first calf. Some hold that she should freshen very young, in order to start on her life's work early, while others say that she should have sufficient age so that her growth might practically have been made prior to that time.

The consensus of opinion differs with different breeds. Breeders of larger dairy cattle contend that the heifers should be two and one half to three years old before freshening, while breeders of Jerseys and Guernseys have, as a rule, contended that a heifer should freshen with her first calf at the age of twenty-four months.

A subscriber has asked about a heifer that is half Durham and half Ayrshire. It would undoubtedly be advisable for her to freshen at the age of from twenty-four to twenty-six months, before the beefy nature she has inherited from her Durham ancestors asserts its influence. If she does not freshen before she is two and a half to three years old, she will begin converting a large portion of her feed into beef or fat and depositing it over her body. On the other hand, if she freshens at two years or even a little before the time she has reached maturity, she will begin at once to convert her feed into milk and butter-fat.

Gaining the habit thus early in life, she will in all likelihood make a very good dairy cow and milk largely and economically. If, however, she is allowed to begin converting her feed into beef and fat, it will be very difficult if not almost impossible to change this habit later in life and in all likelihood she will be an unprofitable producer of dairy products. HUGH G. VAN PELT.

To Cure an Inflamed Udder

J. J. H., Cache County, Utah, writes: "About four months ago my valuable cow had a calf and after calving one quarter of the udder became caked. All I could get from it was blood, and it is swollen and in that condition at the present time. Will it ever get all right?"

From the description it is evident that the udder of the cow has become infected from some cause or other. With proper care at the right time the udder should give milk again. However, the udder of a cow is one of the most difficult portions to treat, as it is so hard to determine exactly what conditions might be found were one able to see the interior. The only way of treating an udder in such a condition is to bathe it well and frequently with either hot water or cold water, as such fomentations, together with the rubbing and massaging with the hands, starts the circulation of blood and renders active the milk-producing glands.

The udder should be milked out very frequently and, while it is infected, even ten or twelve times daily. By thus frequently milking the infected quarter, together with the stimulation of the blood circulation, the infection is gradually taken from the udder. One never can say that the udder will again be in perfect condition until that state of affairs has arrived. All that can be done is to treat carefully and thoroughly in the above manner.

Oftentimes it is helpful to apply hot antiphlogistine to the affected part, covering it with cotton and placing a bandage around the udder up over the hips to hold the cotton and antiphlogistine in place. This is rather difficult of application, but where possible there is nothing better to relieve inflammation. H. G. V. P.

A Hog Barrier

It is often desired to keep the hogs in one pasture or lot while other stock are allowed to go from one to the other at liberty. A barrier that will turn hogs of any size and at the same time allow horses and cattle to pass may be made as follows: In the gap or open gateway nail boards across the opening making a low fence about twenty inches high. Drive two short posts and make another low fence the same length and height as

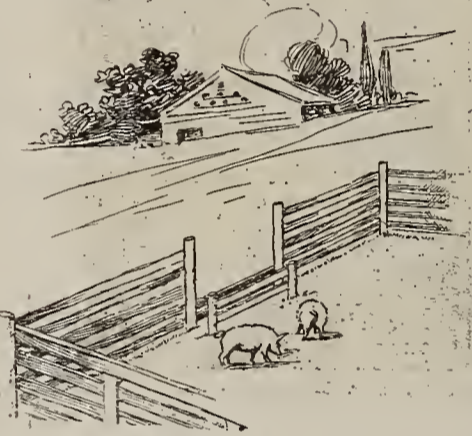

The Open Gate is Hog-Proof

this and parallel to it, about eighteen inches from it on the side where the hogs are to be confined. When the hogs take a notion they would like to see what's on the other side, they will go up to the first barrier, follow along till they get to the end, then go in between the two and out at the other end—for there will not be room enough for them to turn between the two and unless a hog can turn with his head toward it he surely can't jump a board fence. If he is small enough to turn in an eighteen-inch space, he is too small to jump over twenty inches, so there you are. Horses and cattle can step over the two low fences or over one at a time. H. F. GRINSTEAD.

Tracing a Milk Odor

When milk has an acid odor, several different difficulties are to be suspected. If the milk does not have an odor when it is drawn, but develops it afterward, it is probably being contaminated by germs which get into the milk from unclean vessels somewhere in the process of handling it. The remedy is care, scouring and scalding of all utensils regularly. If, however, the milk has the odor when freshly drawn, it is most probably due to some feed, that is being given to the cow, or something she finds in the pasture.

To determine this, however, it is necessary to keep her in the barn for two or three days where all the feed she consumes is known. The difficulty can then be traced down.

A third possibility is an infection or injury to the udder. This, however, generally shows itself in other ways, by swelling, inflammation, pain or an abnormal appearance to the milk. H. G. V. P.

A covered milk-pail with a small opening will lessen the contamination of the milk. The old-fashioned, open-topped pail lets in from twenty to thirty times as many noxious bacteria as the best improved pail.

Contaminated milk from your barn may kill somebody's baby in the city. And uncontaminated milk is simply a matter of clean cows, clean barns, clean utensils and clean people. None of these things is very expensive.

Dairy Facts

LAST year dairy products sold for over \$800,000,000.00. Did you get your share?

Butter-fat brought a higher price this year than ever before. Did you get a higher price?

The Pure Food Law has made perfect cleanliness in the dairy a necessity. Are all of your utensils absolutely sanitary?

Here is the point: Users of Empire Cream Separators got their full share of the eight hundred million dollars; got their full share of the higher price per pound for butter-fat and, without effort, they kept their machines as clean and sweet as the most strict laws or careful creameries could demand. These are facts. Write for the proof.

EMPIRE CREAM SEPARATORS

make cow owners successful because they not only extract all the cream, but Empire cream is quality cream. Also, an Empire lasts—does perfect work for years, not weeks or months, which means that it pays for itself over and over again. Always easiest to turn, easiest to clean, best work savers and biggest money-makers.



Free Dairy Book Shows Different Styles

Take your choice—Frictionless Empire or Empire Disc—Each style made in all capacities—All backed by the Empire Guarantee, as good as a Government Bond. Send postal for book, the best guide to more dollars ever published for dairymen. Address—

EMPIRE CREAM SEPARATOR CO. Dept. A, 1225 Wabash Ave., Chicago, Ill. Factory: Bloomfield, N. J.

THE PRODUCT OF EXPERIENCE AND HONOR

20 YEARS' EXPERIENCE has taught me what is best in Gasoline Engine Construction. The result of that knowledge is

THE CALDWELL SPECIAL

I will ship you an engine and let you set it alongside of any high priced engine on the market and if it doesn't do as good work as any engine built you don't need to keep it—send it back at my expense.

My engines are fully guaranteed for five years, sent on sixty days' free trial if you wish. Write for catalog.

CALDWELL-HALLOWELL MFG. CO. 525 Commercial St. Waterloo, Iowa

Satisfaction Guaranteed



BALE 3 TONS AN HOUR

easily and safely with an Auto-Fedan Hay Press. Only two men required to run it, thus saving one-third the cost of labor. There's nothing complicated to break and get out of order. Three-stroke, self-feed. Easy draft. Smooth, neat bales. Shipped on trial to responsible parties. Send for free catalog No. 7. (3)

THE AUTO-FEDAN HAY PRESS CO. 1507 W. Twelfth St. Kansas City, Mo.

ABSORBINE

will reduce inflamed, swollen joints, Bruises, Soft Bunches. Cures Boils, Fistula or any unhealthy sore quickly; pleasant to use; does not blister under bandage or remove the hair, and you can work the horse. \$2 per bottle at dealers or delivered. Horse Book 7-D free.

ABSORBINE, JR., for manking, \$1.00 per bottle. Reduces Varicose Veins, Varicocele, Hydrocele, Gout, Wens, Strains, Bruises, stops Pain and Inflammation. W. F. YOUNG, P. D. F., 284 Temple St., Springfield, Mass.

No More Sore Shoulders

Never lay off your horse. This \$1.25 Lankford Cotton Filled Collar beats the world. Galls and Sores are impossible because it is an absolute fit. Light, pliable, long lasting, humane. Fits any shaped neck. Booklet tells all. Write for it. Free.

THE POWERS MFG. CO., 138 Sycamore St., Waterloo, Iowa

PATENT YOUR IDEAS

\$8,500 for one invention. Book "How to Obtain a Patent" and "What to Invent" sent free. Send rough sketch for free report as to patentability. Patents advertised for sale at our expense in fourteen Manufacturers' Journals. Patent Obtained or Fee Returned. CHANDLEE & CHANDLEE, Patent Att'ys. Established 16 Years. 935 F. Street, Washington, D. C.

ADMIRAL 2-MAN PRESS SELF FEEDER

CONDENSING PACKER ADMIRAL HAY PRESS CO. KANSAS CITY MISSOURI

Live Stock and Dairy

"Pigs in Clover"

WITH hogs soaring above eleven cents, though corn is fifty-five cents here in Indiana, the neighborhood talk is of the "money in hogs." Of course we have no guarantee that this relation of corn and hogs will continue another year. If it does, the farmer certainly deserves his profit, for he goes right ahead supplying the nation with pork regardless of profits.

In any event, we want to make as large profits on hogs the coming season as it is possible to make, honestly. Practice and experience have demonstrated that corn alone is a very poor hog-feed, but the greatest hog-feed known, when properly balanced. Clover is the premier balancer. Here at Valley View Farm, we always have a piece of clover to fatten hogs on each season. If it is not grown on one of the lots close to the feeding-lots, we figure on what part of the open fields we wish to feed them. This is determined by the amount of shade, the handiness of water and the

fifteen head per acre, and if they were not turned in too early and the season was at all favorable, we might get a load of hay off the same lot. Always allow plenty of space, for it is a sore setback to have your hogs run short of clover right in the pinch of the game.

Plenty of shade and plenty of water are absolute necessities when the warm days come, for the hog that lies and pants the whole day long is working, and his fat goes with his labor.

OMER R. ABRAHAM.

Foot-Rot in Sheep

ON LAND at all subject to foot-rot many sheep will fall lame—more especially the close-wooled breeds on grass. It is especially needful to keep the ewes sound before lambing time, for if not kept in check they may be in a terrible state of lameness when they are too heavy in lamb to be handled. Indeed, the only way to dress a ewe's foot then is to take her by the wool under the throat and pass the other hand under



"The Best Thing We've Got Yet is Twenty-Six-Inch Woven Fence"

quality of the soil, as we always want to feed on the poorest part of the field if other conditions are fairly favorable. Water and shade, though, are two very essential points, in connection with the clover feed-lot.

We have tried several plans for "fencing off a patch" in one of the large clover-fields. First we tried rails. The constant rubbing of the young porkers, fresh from the wallowing-hole, sent these fences tumbling. Plank was too expensive. Wire fence was all right, but the setting of posts and, worse, pulling them at the next plowing put us to harder thinking, for we are like the balance of the human race in this respect, we like to get out of as much hard work as possible.

The best thing we've got yet is twenty-six-inch woven fence.

Full length fence-rails are set to serve as corner posts. These are anchored back to stakes driven in the ground, or, better, a piece of rail set in. Put the anchors pretty well back, say ten or twelve feet, and anchor from the top of your long rail corner post. With only twenty-six-inch-fence at the bottom, this holds nicely.

We cut off some blocks of slippery elm and split them into stakes, something like thirty-six to forty inches long. They were made quite sharp and it would surprise you how fast they can be driven with a maul when the ground is reasonably soft, one staple at the top and one at the bottom is about all that is necessary for fastening the fence to the stakes. As the stretching is done from the corners, it is well to fasten it securely there. We never have had any trouble in keeping fattening hogs in an enclosure of twenty-six-inch woven fence and often our old sows are fenced in with it. Of course, the pigs don't get over, either, but sometimes go through.

We make a gate and haul the "old wagon" into the inclosure. This we feed from, moving it about from place to place as often as necessary.

We almost invariably use an iron kettle or two to water in. A fountain on a barrel we have found to be all right, but they usually get "out of whack" easily. Wood troughs are all right for slop, but become too dry to hold water.

If there isn't any wallowing-hole, we make one. All it needs is a puddle for a starter and his hogship does the rest, provided there is sufficient water when necessary.

The number of hogs per acre depends on the stand of clover, the season and the earliness of turning in. Formerly, for a good set of clover, we figured thirteen to

her belly, take hold of the far side hind leg and pull it gently from under her, so that she goes down easily on her side. Then with the knee over her neck, pinning the head close to the ground, she will probably lie quiet. But this method even should only be resorted to in extreme cases.

On hard ground, on mountain runs and often on strong plow land the wear of the foot will be equal to the growth, and here the foot requires little if any paring. But on soft meadow land the growth of horn will so exceed the wear that it will commence to shell and leave cavities to fill with dirt and set up trouble. Foot-rot is considerably helped on by pastures which have much grass in wet weather.

In curing foot-rot the most important thing is the paring. All the loose horn must be cut away. It is no use being too tender-hearted, as if the whole of the dressed surface is not exposed, treatment is of little use. One good way to apply the remedies is in a long narrow trough which the sheep walk through in single file. When this is used the sheep should be run on straw for an hour, so that the feet will be clean, and then allowed to walk through the trough on the straw again. A strong carbolic solution with sulphate of copper dissolved in it will not only cure, but prevents others falling lame. One form of foot-rot is very contagious, and when a flock is falling lame rapidly, every foot should be dressed as a preventive. They should always be kept in the dry for some hours after dressing, and in a bad attack they should be looked through two or three times a week. In extreme cases I have found it best to keep the sheep on the straw in a shed, and poultice with bread and linseed after putting on the ointment.

There are many ointments used. This is a good one: Burnt alum, one half ounce; corrosive sublimate, ten grains; carbolic acid, two drams; precipitated chalk, two ounces; vaseline, six ounces. Another good one is sulphate of copper, four ounces; sesquioxido of iron, four ounces; acetic acid, three ounces; glycerin, one ounce. Mix with linseed-oil to a paste. Ointments are better than lotions.

With a bad foot I prefer to put plenty of ointment between the claws, then a bit of cotton or clean waste to keep it in, then ointment all over the outer diseased parts, a little waste over that, then a bit of sacking about six inches square, tied fairly tightly just above the hoof, which will not easily come off.

W. R. GILBERT.

Sheep Thrive in Arkansas

IT is often a matter of wonderment to me why there is not more interest taken in sheep in this, the hilly and mountainous portion of Arkansas. Only here and there small flocks are kept, and those usually of the most common scrub breeding. I believe we have an ideal place down here, both as to climate and natural range, for both sheep and goats. There are a few flocks of Angora and grade goats, but not many.

I am past sixty years old and have been keeping sheep on a small scale ever since I was old enough to own property. I have lived in four of the Northern states and for the past twenty-five years here in central Arkansas, and can say that I never saw another place where sheep are as healthy and as easy to take care of. I have not seen nor heard of a case of scab, foot-rot nor lamb scours since coming here. We have dry range, some of it hilly and even mountainous, rocky on the hillsides, an abundance of pure spring water and outside range that will not be closed up for many years at any rate. We have no summer weather too hot for work in the fields, and mild, short winters, so that feeding is not necessary more than three or four months. Bermuda grass makes permanent pasture nearly equal to the blue-grass further north. Japan clover grows thick in every old field that has been turned out and is taking the hillsides and every place where the forest leaves are not too deep.

In southern Michigan I have doctored sheep for foot-rot until I was sick myself and tired of the sight of a sheep. In northern Missouri I dipped for scab until I could smell tobacco for a week. (I don't use the weed myself). And in both places lambs died by the dozens with scours.

The only trouble here is the dogs. To keep sheep out on the range here one wants enough of them so that he can afford to keep some one with them during the day and bring them up at night.

We have no government land now in this immediate neighborhood, but there is plenty of land for sale with range available. Most of the outlying lands have been cut over, but the timber companies prefer to keep such lands, foreseeing the time, I suppose, when timber land will be worth more than cultivated farms.

I am not speculating in land nor sheep, but would like to see this country fill up with those looking for such as we have.

BONNIEVIEW FARM.

The color of milk does not indicate the richness of it. Oftentimes milk which is rich is blue in color and oftentimes milk which is yellow and rich looking is of a rather poor quality.

Did you ever think how little real good is done to milk by straining it? After all, straining milk is a method of keeping ourselves and others from knowing about the dirt. Keep the dirt out. Perfect dairying would be strainerless.



IMPORTANT TO CREAM SEPARATOR BUYERS

Don't make the mistake of assuming that the inexperienced buyer can't see the difference between cream separators.

You can't see the difference in results, in quantity and quality of product, ease of operation, cleaning and durability, of course, without comparative use of different machines.

But there is not a sensible man anywhere who in comparing the DE LAVAL and any other cream separator side by side—the design, construction, finish, assembling and un-assembling of parts, simplicity, manifest ease of cleaning and all around practicability—cannot appreciate the superiority of the DE LAVAL to the other.

And when it comes to practical test, every responsible person who wishes it may have the free trial of a DE LAVAL machine at his own home without advance payment or any obligation whatever.

WHY make so important an investment as a cream separator without being SURE that you are right? You simply have to ask the nearest DE LAVAL local agent or write the Company directly.

The De Laval Separator Co.

165-167 BROADWAY NEW YORK	178-177 WILLIAM ST. MONTREAL
42 E. MADISON ST. CHICAGO	14 & 16 PRINCESS ST. WINNIPEG
DRUMM & SACRAMENTO STS. SAN FRANCISCO	1016 WESTERN AVE. SEATTLE

TRAVELING SALESMEN

Earn the Biggest Salaries of any class of men in the world. Over 600,000 employed in the United States and Canada. The demand for good salesmen exceeds the supply. We will teach you to be one by mail and assist you to secure a good position through our FREE EMPLOYMENT BUREAU. We receive calls for thousands of Salesmen and have assisted thousands of men to secure good positions or better salaries. A great many of our graduates who formerly earned from \$25 to \$75 a month, have since earned from \$100 to as high as \$300 a month and expenses. Thousands of good positions now open. If you want to secure one of them or increase your earnings our Free Book, "A Knight of The Grip," will show you how. Address nearest office for it today. Dept. 429, NATIONAL SALESMEN'S TRAVELING ASS'N Chicago New York Kansas City Minneapolis San Francisco Atlanta

GASOLINE PUMPING ENGINE

It costs about ONE CENT AN HOUR to pump water with this engine. If your time is worth more than a cent an hour you cannot afford to pump by hand: It will raise 32 barrels of water per hour to an elevation of 25 feet, 10 barrels to an elevation of 100 feet, or proportionate quantities to other heights.

This engine can be connected to "any old pump" in 30 minutes. After you have watched it pump water for five minutes you will wonder how you ever got along without it. The longer you have it, the better you will like it. It is right on the job all the time. A turn of the fly-wheel and it is off. A child can operate it. The ladies often start it to pump a pail of water. They rest while it works.

It is shipped complete with walking beam, supporting frame and everything ready to set it up in complete working order, except three stakes for driving in ground.

Next to a windmill, this is the most economical outfit for pumping. We are selling many thousands of them every year, but our sale of Aermotors is still increasing.

A PULLEY for running cream separator, churn, washing machine, ice cream freezer, grindstone or other light machinery is furnished with this engine for \$1.50 extra.

If you need an engine for pumping large quantities of water for irrigating, watering large herds of stock, or for other purposes, our Heavy Back-Gear Pumping Engine for \$100.00 is just the thing you have been looking for. It will raise 125 barrels of water an hour to an elevation of 50 feet, or proportionate quantities to any height.

Our \$75.00 2 H. P. General Purpose Power Engine with Fluted Cooler is the best thing going.

Larger sizes at proportionately low prices.

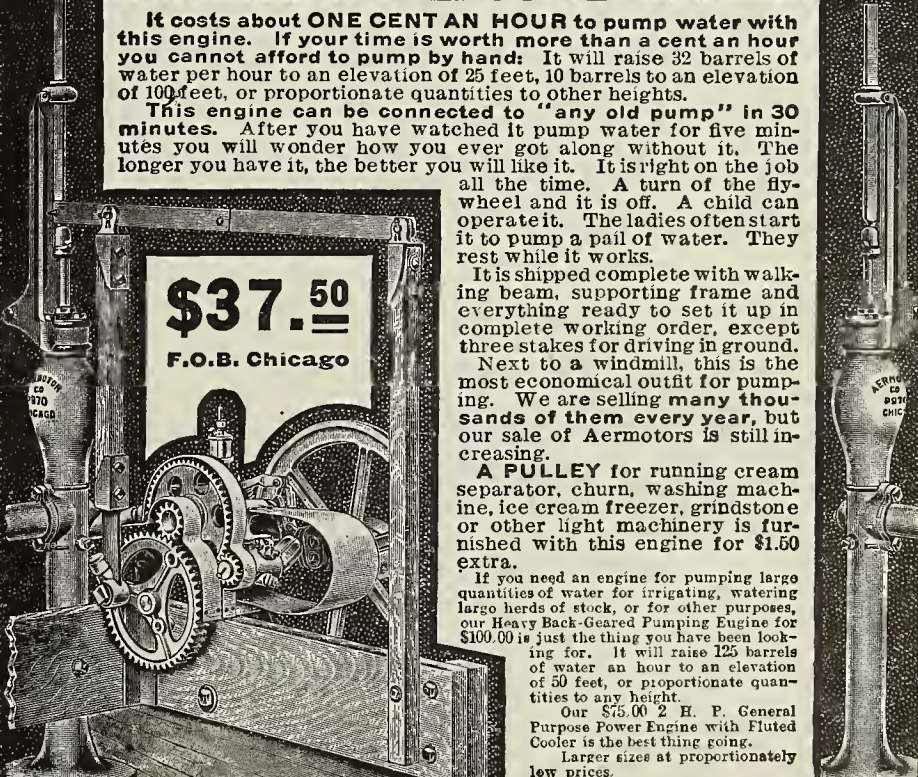

AERMOTOR CO.,

2510-12TH ST., CHICAGO.

CONGO



NEVER LEAK ROOFING

Congo on Armour Fertilizer Works, Buena Vista, Va.

EACH roll of Congo not only carries along the necessary galvanized caps, cement, etc., to lay it properly, but also a *genuine Guarantee Bond*. This Bond guarantees 2 or 3-ply Congo absolutely for 10 years. It is clear-cut and comprehensive. It amply protects the user, and were not Congo the most thoroughly good and reliable ready-roofing of its class, always dependable, always pliable,—no matter where used,—we couldn't afford to do this.

It is a distinct step forward in the roofing business. We not only tell you Congo will last ten years, but we back it up with a *Surety Bond*.

When buying Roofing, get Congo, and you will not make a mistake, or have any regrets—you are buying *certain protection*. Samples and copy of the Bond for the asking.

UNITED ROOFING & MFG. CO.
553 West End Trust Bldg., Philadelphia, Pa.
Chicago San Francisco

120-EGG IDEAL \$7.50 Hatcher—Freight Paid

Other sizes (also Brooders) very low. Metal-covered all round. Safe, simple, guaranteed. Delivered free east of Missouri River and north of Tennessee. If further, write for delivered price. Get poultry guide, free.



MAKE YOUR BICYCLE INTO A MOTORCYCLE

at small cost by attaching the ERIE MOTOR. This includes all parts so that anyone can make a strong, durable machine that will climb steep hills and run for 4c per mile. 1,000 in use. Sample sold at cost. Send 2c stamp today for catalog F.

Motorcycle Equipment Co., Hammondsport, N. Y.

90% Hatches

from the Cyphers—in every country and climate—for old-timers and beginners. For you. **CYPHERS INCUBATORS** and Brooders are non-moisture; self-ventilating; self-ventilating. Write for 160-page Catalog. Address Nearest City.

Cyphers Incubator Co., Department 72 Buffalo, N. Y.; New York City; Chicago, Ill.; Boston, Mass.; Kansas City, Mo.; Oakland, Cal.

Chicken Business There's Fortunes in It. Get Busy. We start you. Most successful Poultry Farm. Thousands to choose from. Buy Eggs for Start. Low prices on fowls, eggs, incubators, etc. Big illustrated, valuable book, "Profitable Poultry," sent for 3 cents. BERRY'S POULTRY FARM, Box 20, Clarinda, Iowa.

Practical Poultry-Raising

The Poultry-Yard in May

THE chicks that were hatched very early are now of a size to meet the demand for broilers. Previous to the period of fattening they should have had plenty of range. The male birds are best used, the pullets being kept for early fall laying. Select the males by their larger combs and heavier feet and legs and confine them in crates eight by four feet and comfortable height. Ten birds in a crate is sufficient. Feed all they will eat of corn and chopped clover and give plenty of drinking-water. For the noon feed I would recommend a soft mash of corn-meal, seven eighths; linseed-meal, one-eighth; moistened with warm skimmed-milk.

Those that attain the desired weight of about two pounds are disposed of. Others that do not come to proper weight in ten days are given their freedom, to be again confined after an interval of a few days.

Where there are no facilities for separating the younger from the older fowls, a very satisfactory feeding-pen is a box-like frame two feet high, eight feet long and four or five feet wide, with upright strips tacked along the sides far enough apart to admit the smaller fowls while the large ones are excluded.

Chicks hatched in May need no artificial brooder heat. They should not be allowed to use the runs occupied by the April-hatched chicks.

Beef-meal may be omitted from the rations of both the May chicks and the grown fowls that run at large as the grub and insect world affords abundant animal food. M. ROBERTS CONOVER.

Of What Use Are Games?

A GENTLEMAN visiting my farm the other day made this remark: "I can see the utility of Wyandottes and Leghorns, but of what use are Games?" The exhibition Game is probably the most interesting fowl we have to-day. There are indications that the "cock crow" which Peter heard was from a game cock and it is a well-known fact that the Romans at the time of Caesar were great admirers of this variety. Whether Caesar introduced the fighting-cock into England or whether he found it there and introduced it into Rome is a matter of historical controversy, but the records indicate that from early times the Englishman was fond of fighting-cocks.

About seventy years ago, when England enacted rigorous laws prohibiting Game fighting, the fanciers undertook to make of it an exhibition bird, selecting only those with feathers true to a certain standard and, as in the fighting days, the bird that was most upright

was the most likely to win, so the tendency has been to develop the uprightness or "station" as it is called in the Standard. Unfortunately the tallest birds are the most delicate and this has somewhat hurt the breed.

"Why are they not more raised?" The only explanation is that in our poultry development in the United States we have followed the line of least resistance, and paid more attention to quantity than quality. But now in regard to the usefulness of the Game I will say that, after breeding them several years, I have found that the hens during a year produce as many eggs as any other average hens, and any one who is a judge of the quality and flavor of a medium boiled egg will give the prize every time to an egg from a Game fowl. Furthermore, there is no fowl which equals a good Game fowl, about a year old, on the table. The fowl has a gamey flavor and is as different from an ordinary market fowl as is a turkey.

As I have said, we have worked along the line of least resistance and raised those fowls most easily raised. Most



A Golden Duckwing Game Cockerel

people, when they have failed in trying to raise Game fowls, blame the breed, not the faults of their methods. The Game, like all other well-bred animals, does require a little more attention, but when once it is started it is as hardy as any other fowl. Certainly the Game is a fowl worthy of more consideration by farmers, as well as fanciers.

A GAME BREEDER.

Many folks think that hens can and will eat anything that is given them and do well on it. They will eat everything, but they will not do well on it. Hens ought to have good clean pure feed to keep healthy and lay lots of eggs.

Hens and Space

THE inquiry is often made by those who are thinking of taking up poultry-keeping, "How many hens can I care for on an acre of land?" Just now an inquiry comes from a subscriber, "Will you please tell me how many hens I ought to keep on two acres?"

It is not very clear whether the last-named friend means that he would like to grow all the crops he can on his two acres and wonders how many hens he could support on such a place or whether he would depend mostly on feeding grain and other things bought in the market. So only a general answer can be made.

If the colony plan is adopted, not more than one hundred hens should be placed on an acre. This method calls for a number of houses some distance apart, with yard for inclosing the stock. Only twenty-five or thirty hens should be thus yarded together, and four houses to the acre is about right.

Some of the best poultrymen, however, believe they get the most satisfactory results by closely confining their stock. The number of fowls can then be much greater and no one could definitely fix it. No one that has not had experience ever should take up this method; he will be sure to fail. The best way, no matter what method is in view, is to begin with a few hens, not more than a year old, and gradually work up. Take the case of the friend with two acres. Begin with a few good hens. Let them have free range. Do not overcrowd them. Study your business. Watch your stock. Gradually add a few to your number. As the size of the flock grows, build more houses. As you learn how to manage poultry better, try smaller pens and closer confinement.

Poultry kept in small yards must be kept absolutely clean and otherwise well cared for. Means must be taken to make the birds exercise, they must be fed on time every day, on a good variety of food.

I have now in mind a man who thought he could do an intensive poultry business on a small piece of land. He hatched chicks by the thousand—and lost them by the thousand. He soon went out of the business discouraged; but the worst of it is that same man is to-day trying to make a fortune telling how much money ought to be made by following the plans he tried himself so disastrously.

E. L. VINCENT.

Managing the Chicks

NOW that the young chicks are coming in endless numbers, it is a steady task to supply their wants in regard to food, shelter, exercise and protection. They should have a house by themselves to sleep in, whether with their mother hens or in a brooder. This house should be accessible to them in the day-time in case of storm. If they are trained properly from the start, they will cause but very little trouble and seek shelter at the right time. In this house there should be roosts set low, so that as soon as any are large enough they will of their own accord occupy them. This prevents huddling and crowding together.

Although it may be necessary to confine the mother-hens, the young chicks should have reasonable range, where they can obtain exercise and all the grass they desire. They should not, of course, be allowed to wander everywhere without the hen's escort, or some are certain to be lost or killed, but a large run is an advantage. If the old hens are confined closely, they must be supplied with some kind of green food.

At least every second day a part of the lot should be spaded, in order to let both hens and chicks get at the worms and bugs, which will be a regular feast for them and also keep them exercising. It will also furnish a place for a dust bath, which will be highly beneficial. I prefer feeding in troughs and hoppers. Have fresh water always on hand. Sweet milk, or a mixture half water and half milk I have found very beneficial to growing chicks.

Water should be given in a vessel so protected that chicks cannot muddy it. Shade should be provided and their premises kept clean and frequently sprinkled with air-slaked lime, to purify and disinfect. I give regularly small quantities of pulverized charcoal to insure good health.

In case of mites a thorough application of coal-oil on roosts and sleeping-quarters will usually clean them out. This should be done in the morning so the smell of coal-oil will have abated by roosting-time.

MRS. C. S. B.

Thrifty Chicks Make Paying Fowls

That's reason and common sense. What the chick is, the fowl will likely be. The important matter, then, for every poultry raiser is to give the growing chickens a *good start*. Not at all a difficult thing to do, either, if you get Dr. Hess Poultry Pan-a-ce-a to help you. This is a Tonic to mix once a day in the soft feed—a system known among poultry men as "**The Dr. Hess Idea**" of feeding. Only a little of it is needed, but its effect is surprising. You can almost see and measure the daily development of the little peepers, from tender weaklings to vigorous, growing young fowls.

DR. HESS Poultry PAN-A-CE-A

Will carry them on from the growing stage to early maturity and pay you abundantly for the little extra attention you have given them. It cures Gapes, Cholera, Roup, etc.; it makes the pullets lay *early* and keep it up the whole season round, because it acts on the *digestive organs* of the hen and gives her power to assimilate large quantities of food and turn it into eggs. In the same way it helps to fat the cockerels and other birds you wish to sell. It gives strength to pass the moulting season and *good health* always. A penny's worth feeds 30 fowls one day. Sold on a written guarantee.

1½ lbs. 25c; mail or express 40c.
5 lbs. 60c, 12 lbs. \$1.25, 25 lb. pail \$2.50.
Except in Canada and extreme West and South.
DR. HESS & CLARK, Ashland, Ohio.

Send 2c for Dr. Hess 48 page poultry book, free.

DR. HESS STOCK FOOD

Is a guaranteed animal tonic, formulated by an experienced live stock farmer (Dr. Hess, M.D., D.V.S.) for the sole purpose of bringing about an economical system of feeding. It acts on the *digestive organs*, keeps them healthy and *active* and relieves the minor stock ailments. The animal receiving it can consume and *put to use* a large ration. Thus it helps the cow to give more milk and the steer, sheep or hog to fat quicker. No live stock owner can afford to do without Dr. Hess Stock Food. Fed twice a day in small doses. Sold on a written guarantee.

100 lbs. \$5.00; 25 lb. pail \$1.60, except in Canada and Extreme West and South. Smaller quantities at a slight advance. Send 2c for Dr. Hess Stock Book, free.

INSTANT LOUSE KILLER KILLS LICE

Farm Notes

Ant-Proof Hive-Stands

EVERY bee-keeper has more or less trouble with ants that gain entrance to the hives. They are not only a nuisance, but a cause of loss as well.

At the request of a bee-keeper I designed the stand illustrated in Fig. 1, which gave excellent satisfaction. The hive is placed in the center of it, entirely surrounded by a groove or channel in the concrete, which may be filled with oil or water, thus making it an impossible barrier to ants and small vermin; while the part on which the hive rests is made large enough so that the bees have ample room to alight and enter the hive without coming in contact with the protective composition in the channel.

The entire stand is made of concrete in an easily-prepared home-made mold

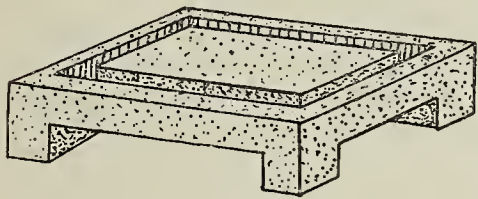

Fig. 1

which enables them to be built at a cost of less than ten cents each, which is as low as any good stand may be built; furthermore, the concrete stand is everlasting as well as an ornament to the yard.

To make the mold, a board is prepared for the bottom or pallet, as large as the entire stand is to be. Upon this a three-fourths-inch strip is nailed so that it reaches entirely around the edge of the pallet one inch in from the outside edge, as shown in Fig. 2. This molds the channel or groove in the top of the stand for the oil or water. Four boards are now prepared, long enough to reach entirely around the outside edge of the pallet; these are seven inches high, which makes the stand six inches high when a board one inch thick is used for pallet. These four boards are cut out in the center by sawing into them three inches

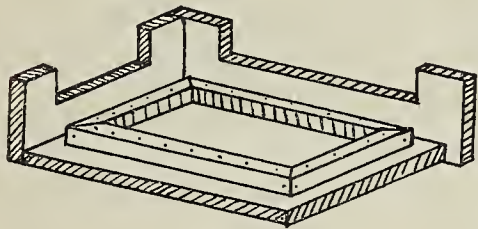

Fig. 2

at a point six inches from each end and breaking out this piece, to make them the form illustrated, which permits the legs to be easily molded. These boards when finished are hinged together at three corners and the fourth corner fastens with a hook and eyelet; so that when the work is molded the form may be unhooked at one corner and folded back from the work.

The concrete is filled into form and tamped down solid up to the top edge of the cut-out part of the side molds. Then a form is made by nailing two seven-inch boards together at right angles; these are three inches wide and are laid on the concrete already placed at each corner, so that a square form is made there, into which the concrete is tamped, thus molding the legs to the stand, as illustrated in Fig. 1.

A number of these stands can be molded in a day, it being possible to provide several pallets and use one set of outside and leg forms on all of them.

A. A. HOUGHTON.

Intensive Schooling

FIVE years ago two adjoining school districts in Lynd Township, Lyon County, Minnesota, each needed a new building. Mr. O. C. Gregg, then state superintendent of farmers' institutes, suggested consolidation. The question was discussed for some months among the farmers and the final vote was for a two-room semi-graded school. The children began to come in to the better school from surrounding districts and within two years the building was too small to accommodate them all. This year they have a four-room graded school which has just been put on the state list for six hundred dollars special state aid. The rural districts did not receive aid from the state.

Figures taken from the clerk's reports of seven adjoining rural districts show that, last year, the average cost per pupil was a little over thirty dollars, the

schools being open an average of one hundred and three days, while the Lynd consolidated school kept one hundred and one children in school for an average of one hundred and thirteen days at a cost of fifteen dollars per pupil.

The transportation of pupils was one of the most difficult problems. Each family living one and one-half miles or more from the school-house receives twenty dollars for the extra trouble of sending the children to school during the year, the district furnishing the barn for their horses. Nine families were paid in this way last year and at the annual school meeting the plan was voted a success and five hundred dollars raised to continue it, although all of this amount will not be used.

Increase of taxes did not prove so serious as the transportation question. Taxes did rise, but the rise in value of all property in the district more than made up for the rise in taxes. There is little dissatisfaction from this source now.

That the children receive better training is not questioned. Better equipment, better-paid and better-trained teachers make the difference in favor of the consolidated plan. On the whole, the tax-payers of Lynd are very well pleased with the change they made.

H. R. PAINTER.

Make Fewer Acres Do More

A. P., INDIANA, says he is renting a large place which he is farming, but he has purchased forty-five acres near a large city, on which he owes two thousand dollars. He is in a quandary as to what he shall do, drop the large place and move onto the small farm or stay where he is. If he is doing well, he would better stay where he is, at least until he pays off the debt on the other farm. If he is not doing well or he and his family are working too hard, it would be best, after this season, to sell his implements and extra stock and go to the smaller farm.

Hundreds of farmers are discovering that they can make two to ten times as much clear cash a year farming a small place that they own than farming a large place somebody else owns. The owner of a tenant farm gets from one third to one half of every penny a tenant farmer can wring from the soil. A farmer once said to me: "When I fully understood that half of every penny I made went into the pocket of my landlord, I think I turned pale. I had worked tenant farms nearly ten years before I saw the light. Then I made up my mind that I was done farming as a tenant, if I had to get down to one acre that was my own." He bought ten acres one mile from a large town and began intensive farming for himself. He grew potatoes, sweet corn, pop-corn, cabbage, turnips, melons, squash, strawberries, raspberries, grapes, cherries, etc., and was soon making more than he ever made on the large farm.

A. P. will have to learn intensive farming on his little farm. Intensive farming is doing ordinary farm work so thoroughly that the yield of the crops grown is brought up to a maximum, instead of an "average." Three fourths of the land will yield from a third to a half more than it now does when it is farmed right. In a few more years the slash-and-slasher method of farming will disappear and the work will be done skilfully and thoroughly. There will be more profit in such farming.

FRED GRUNDY.

Occasional Notes

Combination is still the order of the day. The phosphate deposit owners in the South met at Tampa, Florida, February 17 and 18 and formed an association which is to meet annually. From Tampa alone one million seven hundred thousand tons were shipped in 1909. To do things, organization is essential.

In the maritime provinces of the Dominion of Canada field-crop competitions under the supervision of the Department of Agriculture are creating much interest in advanced methods of farming. Prize money is granted by the government for increased yields and improved quality.

The Japanese seed-oyster of the famous oyster districts of Hiroshima is being imported at Seattle for transplanting in the Willapa Bay, Washington. The Japanese oyster is known as the quick-growing one and is the only one that is well adapted for culture in the cold Northwestern waters. J. W., JR.

GET A GUN!



Kill Off The

Crop Thieves and Poultry Pilferers

Gophers Weasels Rabbits Hawks Crows Skunks Wood Chucks Blue Jays Sparrows

A big family of farm pests. The four-footers outrun your dogs—the others laugh at your scare-crows. But there's one thing they can't get away from and that is a bullet fired from a

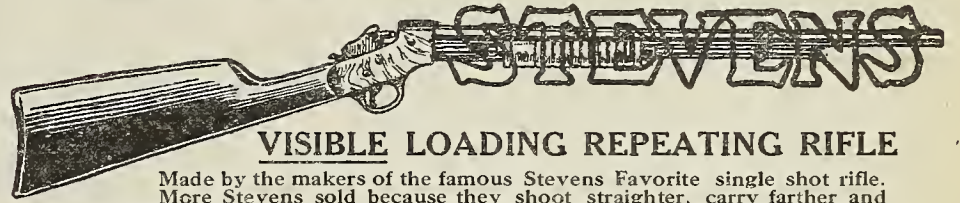

VISIBLE LOADING REPEATING RIFLE

Made by the makers of the famous Stevens Favorite single shot rifle. More Stevens sold because they shoot straighter, carry farther and hit harder on account of the extreme care used in our system of accurate rifling. If your dealer hasn't it we will send express prepaid on receipt of List Price \$8.00. Ask for Number 70. With this wonderfully accurate Rifle (which only weighs 4½ pounds) you can send a hail storm of lead into the boldest weasel or the craftiest fox that ever robbed a hen coop.

Two models: The first takes fifteen .22 Short cartridges only. The second takes any one of three cartridges—.22 Short, .22 Long and .22 Long Rifle but the greatest accuracy is obtained in this model by using only .22 Long Rifle cartridges. You see the cartridge go into the chamber—you know when the rifle is loaded. You don't have to think whether you have another shot or not! Each cartridge as it comes out of the magazine shows plainly before it passes along into the chamber. We guarantee this Rifle to be the most accurate .22 Calibre Repeater in the world. Rifled in the Stevens Factory of Precision—which is celebrated for turning out the most accurate rifles in the world—the Visible Repeater is one of the very best of the celebrated Stevens family. This Visible No. 70 is a man's gun for man's work but it is light enough for your boy to use and is a splendid rifle to practise with. With this wonderfully exact gun you absolutely know that the bullet will go just where it is aimed. It isn't every gun that will shoot straight. The Visible will do its share of the hitting—it's up to you to do the aiming. After the first shot remember that you have fourteen more lightning shots without reloading.

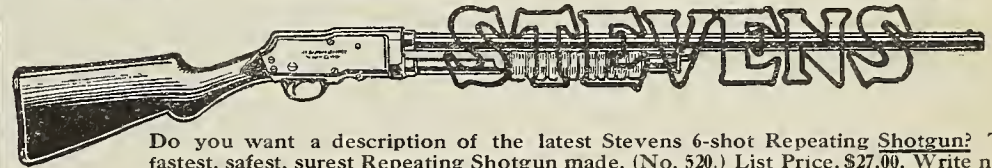

Do you want a description of the latest Stevens 6-shot Repeating Shotgun? The fastest, safest, surest Repeating Shotgun made. (No. 520.) List Price, \$27.00. Write now; right now—while you remember it.

Points for the Sharpshooter, Hunter & Trapshooter:

Write us and tell us what kind of shooting you are most interested in and we will write a letter of advice with many valuable pointers for the Hunter and Sharpshooter. We will give you short cuts to expert marksmanship, which will not only make you a better shot than you already are but will cut down your ammunition bills as well.

J. STEVENS ARMS & TOOL COMPANY, Dept. 735, CHICOPEE FALLS, MASS.

THE FACTORY OF PRECISION

List Prices of Stevens Rifles

Little Scout No. 14	\$2.25	Favorite No. 17 (The Only Boy's Rifle used by Men)	\$6.00
Stevens-Maynard Jr. No. 15	3.00	Visible Loader No. 70	8.00
Crack Shot No. 16	4.00	Ideal Rifle No. 44 (Man's heavy Single Shot Rifle)	10.00

(For Young Shooters. Accurate and made for real work.)

Watch Fob Given to Bicycle Riders

Send your dealer's name with 4c postage and we will mail this handsome fob. Also catalog illustrating and pricing our high-grade Indianapolis G & J TIRES. Admitted by bicycle manufacturers and riders to be the best made. Wear longest, ride easiest and are most convenient to repair. G & J TIRE CO. Indianapolis, Ind. Address Bicycle Tire Dept.

Unfailing Speed When You Need It

Distance is a real danger in farm emergencies. The R. S. Motorcycle eliminates distance, summons help, takes aid or messenger on the wings of the wind, brings back the man and the remedy. No matter how urgent your need—you cannot make a call on R. S. speed, power, reliability and endurance that the mighty R. S. engine can not meet with enough and to spare. Write for catalogue and name of nearest R. S. agent. Agents wanted where we are not represented.

READING STANDARD CO. 423 Water Street, Reading, Pa. Makers Renowned Reading Standard Bicycles

It is to your advantage to mention Farm and Fireside in writing to advertisers. Farm and Fireside folks get the very best attention.

10 DAYS FREE TRIAL

We will ship you a "RANGER" BICYCLE on approval, freight prepaid to any place in the United States without a cent deposit in advance, and allow ten days free trial from the day you receive it. If it does not suit you in every way and is not all or more than we claim for it and a better bicycle than you can get anywhere else regardless of price, or if for any reason whatever you do not wish to keep it, ship it back to us at our expense for freight and you will not be out one cent.

LOW FACTORY PRICES We sell the highest grade bicycles direct from factory rear wheels, inner tubes, lamps, cyclometers, parts, repairs and everything in the bicycle line at half usual prices. Highest grade models with Puncture-Proof tires, Imported Roller chains, pedals, etc., at prices no higher than cheap mail order bicycles; also reliable medium grade models at unheard of low prices.

RIDER AGENTS WANTED in each town and district to ride and exhibit a sample 1910 "Ranger" Bicycle furnished by us. You will be astonished at the wonderfully low prices and the liberal propositions and special offer we will give on the first 1910 sample going to your town. Write at once for our special offer. DO NOT BUY a bicycle or a pair of tires from anyone at any price until you receive our catalogue and learn our low prices and liberal terms. BICYCLE DEALERS, you can sell our bicycles under your own name plate at double our prices. Orders filled the day received.

SECOND HAND BICYCLES—a limited number taken in trade by our Chicago retail stores will be closed out at once, at \$3 to \$8 each. Descriptive bargain list mailed free.

TIRES, COASTER BRAKE and everything in the bicycle line at half usual prices.

DO NOT WAIT but write today for our Large Catalogue beautifully illustrated and containing a great fund of interesting matter and useful information. It only costs a postal to get everything. Write it now.

MEAD CYCLE CO. Dept. B-83, CHICAGO, ILL.

SUBSCRIPTION PRICE

One Year (24 numbers) 50 cents
 Canadian Subscriptions . 1 Year, 75 cents

Entered at the Post-Office at Springfield, Ohio, as Second-Class Mail Matter.

Subscriptions and all editorial letters should be sent to the offices at Springfield, Ohio, and letters for the Editor should be marked "Editor."

The date on the address label shows the time to which each subscriber has paid.

Subscribers receive this paper twice a month, which is twice as often as most other National farm journals are issued.

Silver, when sent through the mails, should be carefully wrapped in cloth or strong paper, so as not to wear a hole through the envelope.

When renewing your subscription, please say it is a renewal, and if possible send the label from a recent copy. If all our subscribers will do this a great deal of trouble will be avoided.



PUBLISHED BY

THE CROWELL PUBLISHING COMPANY

SPRINGFIELD, OHIO

Branch Offices: 11 East 24th Street, New York City

Tribune Building, Chicago, Illinois

Copyright, 1910, by The Crowell Publishing Company

ABOUT ADVERTISING

FARM AND FIRESIDE does not print advertisements generally known as "readers" in its editorial or news columns.

Mention FARM AND FIRESIDE when you write to our advertisers, and we guarantee you fair and square treatment.

Of course we do not undertake to adjust petty differences between subscribers and honest advertisers, but if any advertiser in this paper should defraud a subscriber, we stand ready to make good the loss incurred, provided we are notified within thirty days after the transaction.

FARM AND FIRESIDE is published on the 10th and 25th of each month. Copy for advertisements should be received twenty-five days in advance of publication date. \$2.00 per agate line for both editions; \$1.00 per agate line for the eastern or western edition singly. Eight words to the line, fourteen lines to the inch. Width of columns $2\frac{1}{4}$ inches, length of columns two hundred lines. 5% discount for cash with order. Three lines is smallest space accepted.

Letters regarding advertising should be sent to the New York address.

The Way to Gain by the Canal

WE HAVE suggested that Admiral Evans' anxiety regarding our merchant marine is rather uncalled for; but his fine articles in Hampton's on the best use to make of the Panama Canal are the most thought-provoking yet published on that important topic.

The admiral pleads for a canal which shall be free of tolls, a real people's highway from the Atlantic to the Pacific. He shows that if tolls are collected which will pay interest on the cost of construction, merchant vessels cannot use it. A few might do so, but that no considerable number will, he proves by figures dealing with the expense of coal and labor, as against the cost of passing through the Panama ditch.

This is most important. We are spending nobody knows how many millions on the canal, but probably well toward \$400,000,000. Naval authorities say that while it will be convenient in transferring warships from coast to coast in time of peace, no fleet could be sailed out of it in the face of a foe, since there is no way for it to emerge save in single file, and even a small fleet in line of battle outside could sink vessels as fast as they appeared. Therefore, if the canal in which we are investing so much treasure is to be of any considerable use, it must be of commercial utility. Our money will be wasted, and we shall meet with national disappointment, unless we can make our money back in lowered freight rates.

This Admiral Evans thinks we can do if we make the canal free of all tolls. He asserts that freight might be brought from coast to coast by ship through a free canal at one fourth the charges now paid the railways. Most people will say on first thought that perishable freight could not go through the canal by reason of the heat of the tropics and the long time required. As a matter of fact, the time would be only about eighteen or twenty days, and that is much less than the refrigerator car requires. As for the heat, it must be remembered that there are refrigerator ships as well as refrigerator cars, and that an enormous tonnage could go with no danger of damage and in ordinary vessels.

* * *

The managements of the transcontinental railways doubtless had these things in mind during the long years of their successful opposition to the Isthmian canal. Let nobody think that that opposition is over because we have the canal within sight of completion. Every chief engineer who made good on the canal was tempted away by the railways, until Colonel Goethals, an army officer, was detailed to take charge. When the railway people read accounts of the way the expenses of the canal are running up, they are doubtless pleased, thinking that the fixed charges will be so great as to keep rates through the canal high enough to make it harmless as a competitor that would force down transcontinental rates.

The time is past for toll roads owned by the people. We have undertaken to build the canal, and we can afford to pay the interest on \$400,000,000, huge as the sum is, rather than lose the principal. The cutting of transcontinental rates in half will make the transaction a profitable one. A free canal would give an impetus to agricultural prosperity on the Pacific Coast, for which it has long waited, and it would give the entire country cheaper oranges, lemons, grapes and all the varied products which the coast produces for us. In all probability it would cause readjustments of freight rates in the mid-continent regions, especially those tributary to the Great Lakes and the Mississippi River.

Furthermore, the free canal seems to be the best way to develop a merchant marine. For the trade from coast to coast, while carried on in great ocean freighters, is in law a coastwise trade, and must be done in American vessels. The British ships, whose activities so vex the soul of the good admiral, would be out of it. We should gradually build up for the Isthmian trade a fleet of ships admirably adapted to auxiliary use in time of war as colliers and the like. Altogether, should we not demand that the canal be made free? And if not, why?

Guesswork receives guess wages.

On the down-hill jaunt it is no credit to set the pace.

The plants that spring from the seeds of hate bear bitter fruit.

If people resemble what they eat, the world should become less hoggish as pork gets scarcer.

Half a loaf may be better than none, but it will pay to put in a little more energy and get a whole loaf.

Rough lumber will make a house, weather-boarding a residence, architecture a mansion—but only human love can make a home.

Feeding the dairy cows well one day and giving them a half ration the next is a plan that will insure a decrease in the milk-flow, as well as a falling-off in cow-flesh.

Food Riots in New York

WE HAVE read of mobs marching through streets howling "Bread or blood!" but it has not seemed possible that such things could ever happen in America. And yet, recently, in the congested East Side districts of New York City, there have been riots of protest against the high price of meats. A boycott against meats originated in Harlem and the Bronx regions of the great city, and spread to the lower East Side. Being mostly confined to the Jewish population, it affected most strongly the dealers in "kosher" meat, or meat that is "clean" according to the Jewish ritual. From boycott, it intensified into combined boycott and riot, affecting nearly all the restaurants and shops where kosher meat is sold. Women were most fanatical, as is the case with most city mobs. They poured kerosene upon meat in the hands of purchasers and delivery men, and even entered shops and oiled the meats in stock. The dealers closed their doors and marched in their turn on the United Dressed Beef Company, the local concern of the Beef Trust, and made such a threatening demonstration that the police had to be summoned.

We have never attached much importance to these boycotts and riots as movements likely to affect the price of live stock. Habits of eating are changed permanently only through the compulsion of stern necessity. People will not abstain from meats because they resolve to do so, but only when they must, and it is this possible "must" that makes the food riots of selfish concern to farmers. As indications of checked consumption of meats through inability to buy, they may mean much. The increased cost of living amounts to a lowering of the actual wages of labor (not the nominal wages, which may even increase), and with this comes that lowered standard of living on the part of wage-earners which makes for low prices for farm produce. The increases lately reported in the money pay of large numbers of wage-earners may serve to save the situation. In the meantime, we must all be impressed at the thought of food riots in America.

* * *

Lots of folks are down in their luck because they're not up in the morning.

If you expect the soil to deliver the goods, you must pay it the price in advance.

A Nebraska farmer who hauled a four-hundred-pound hog to market in an automobile remarked that he received such a price for it that he felt as if he had been chauffeur to a trust magnate.

Many a farmer is ignorantly selling the birthrights of his sons and daughters, not as did Esau, for a mess of pottage, but for a lack of potash and other fertilizers to rejuvenate the soil he is robbing.

A man representing himself to be in the employ of the government has been calling on farmers with the intelligence that if they wished their rural routes continued to sign a petition to that effect on a form he carries. Later the signature shows up in the shape of a small check at a local bank.

Bluebirds, Wrens and Martins

THE blessings showered on us without our efforts are seldom appreciated. The forests formerly sent to our caves, our walls and our hollow trees the wrens, bluebirds and martins that made the place vocal with bird-music—and we never appreciated them as we now do. Blessings brighten as they take their flight—and the bird choir is a blessing of that sort.

That pest of the land, that feathered vermin, the English sparrow, is driving the pretty and companionable birds away. But we can still do something to keep the old friends alive and in some sort of prosperity. Wren-houses may be made, into which the sparrows cannot enter. Houses for bluebirds and martins may be built and put up where the sparrows can be fought off from them in autumn, winter and such spring and summer months as the notions of the legitimate occupants will permit. A boy with one of those air-rifles that shoots a double B shot will make the place one of bad repute for the sparrows, and if he never shoots at any other bird, they will gradually learn that the popping of the gun means nothing for them.

Besides, the sparrows may be poisoned. The United States Department of Agriculture publishes a bulletin on modes of destroying them. If we should all get together and move all along the line in a war for the extermination of the sparrows, we might not win completely, but we should make life easier for the song-birds and our farms much pleasanter places in which to live. As for the profit, there's that to be figured on, too.

Think of your woods and orchards without birds!

Of empty nests that cling to boughs and beams

As in an idiot's brain remembered words

Hang empty 'mid the cobwebs of his dreams!

Will bleat of flocks or bellowing of herds

Make up for the lost music, when your teams

Drag home the stingy harvest, and no more

The feathered gleaners follow to your door?

* * *

It is more important for the farm to support a home than a bank account.

One way to indorse our neighbor's work is to imitate him, but it is due him, as the beginner, first to offer words of commendation and in a way get his consent.

A Vanishing Postal Deficit

THE administration proposal to raise the rates on second-class mail was ostensibly occasioned by a deficit of \$17,480,000 handed down from the preceding year. On the last of March, Postmaster-General Hitchcock was able to predict that all but about \$7,000,000 of this will be wiped out this year. The Post-Office Department made money the first quarter of the present year. It made \$2,115,000, to be exact. It seems to be making more money than ever before in the history of the country. Still, however, Mr. Hitchcock harps on second-class mail rates, and still he is silent on railway mail pay. "I am now firmly of the opinion," says he, "that a proper postal charge on periodical matter would wipe out not only the postal deficit, but would cause a sufficient surplus of receipts to warrant one-cent letter postage."

It is to be hoped that it is his desire to cheapen letter postage to one cent, and not any grudge at the periodical press that inspires this continued dwelling on the "proper charge on periodicals." Everybody but the administration, however, seems of the opinion that the periodicals are to be credited with much of the first-class mail on which the department makes its profits, and that a thorough overhauling of the department's business methods would result in economies which would make penny postage possible with no change in second-class rates. No reputable periodical wants special favors in the way of rates. But they all demand reforms in methods, following searching investigation of the deficit and its causes. Moreover, the passing of the deficit will not excuse the continuance of bad methods. The investigation and reorganization should go on, anyhow. Lax and antiquated methods and the wastes incident to the mixing of machine politics with postal business should be eliminated before any one's rates ought to be boosted.



The FARMERS' LOBBY.

By Judson C. Welliver

Forebodings of a Political Overturn . . . A Disappointed President, a Disgruntled Cabinet . . . Warnings From Massachusetts and New York . . . Senator Hale Goes Into Retirement, Aldrich Into Ambush . . . An Insurgent-Democratic Congress the Probability Next Fall

THERE is some mild effort at legislation in Washington, but nobody talks or thinks seriously about anything except politics and the possibilities for next fall. In other years, at this time, talk has concerned the legislation and its probable effect on the fortunes of the party in power. To-day, nobody seems to think the doings of the current congressional session will have any particular influence; and, frankly, I agree with everybody.

There has been of late a cumulation of political happenings that has prepared the public mind for something revolutionary, and nobody seems to doubt that it will happen. I hear Republicans on all hands expressing the belief that the next house of representatives will be controlled by the Democrats; and they don't even seem to mind it much. It is always bad form to quote the President; but he has said of late to a long list of people, in substance, that he expects the country to elect a Democratic house the coming autumn, and he feels that in doing so it will make an unfair and premature judgment of his administration. He believes that if the next house is Democratic, it will foreclose all his opportunity to "make good" with the country. He believes that if he could have four years of opportunity, he would leave as a monument the greatest and most effective showing of constructive legislation that any President has achieved since the Civil War. But, sincerely believing all this, the President also anticipates that his party will lose in the autumn elections; that it will not have another chance during the administration; and that there is serious prospect that the next President will be a Democrat.

These are plain statements of fact, so well recognized and so constantly talked about in Washington that nobody regards them as in any wise seriously confidential. President Taft is utterly discouraged with the country's attitude of mind. He considers that the tariff legislation has been utterly misrepresented to the country, that the press has been hostile without cause and that his side has not been anywhere stated. Indeed, I violate no confidence in stating that the President has been more than once quoted lately as saying that if there were a way out of it all, he would be glad to quit and get out. He knows there is no way. No President has ever resigned, and Mr. Taft is not the sort of man to establish a precedent of that kind. He is going courageously ahead, keeping up a good front and hoping that the turn of events will bring a situation in which his administration may yet be tardily done the justice that he firmly feels has thus far been denied to him.

* * *

THE President's cabinet is reputed to be gravely affected with the inevitable disaffection incident to a discouraging political situation. There have been insistent reports that Secretary Knox and Secretary MacVeagh are anxious to leave and that Postmaster-General Hitchcock will not remain long. None of these stories seems to have much foundation, though politicians are agreed that the cabinet has been one of the causes of the slack confidence in the administration.

Secretary of State Knox resigned a seat in the Senate from Pennsylvania, which he would probably have been able to hold so long as he lived, to enter the cabinet. It was explained at the time that Mr. Taft had declared that Mr. Knox was to be a real premier—a chief adviser—a lieutenant and right hand of the President in making policies. If Mr. Knox expected any such new eminence in the cabinet, he must be a disappointed man. Far beyond all others of his official family, Mr. Taft has taken Attorney-General Wickersham to his bosom and to his confidence. This is reputed greatly to have miffed Mr. Knox, and without doubt it has offended the sensibilities of many people in and out of Congress who are narrow enough to fail to understand how a Wall Street lawyer, as Mr. Wickersham had been all his life until he entered the cabinet, could well change front so completely as to be an effective prosecutor of about everything in Wall Street. Mr. Wickersham, in short, has been an unpopular member of the administration. Mr. Knox's foreign program, as to Nicaragua and Manchuria, has not pleased the public. The administration's tariff law has been almost universally unpopular, and the railroad bill of the present session has been violently attacked.

All this was nebulous and vague until the returns came in from the Fourteenth Congressional District of Massachusetts and from the Rochester district in New York. Less than two years ago each district elected a Republican to the House by immense majorities, the Massachusetts district by fourteen thousand, the New York district by ten thousand. Now, each of them has so far reversed itself as to have elected a Democrat by large majorities. Likewise, only a few weeks earlier, a Missouri district in an extra election turned up the largest Democratic majority it had shown in a decade, despite that nothing like a full vote was polled.

These things are not to be accounted for as merely local and sporadic manifestations; and nobody regards them longer in that light.

The feeling of impending disaster to the Republicans might not have been so weighty, however, but for some things which took place right on the heels of the election in the Rochester district. I refer, of course, to the announcement by Senator Aldrich, of Rhode Island, that he will not again be a candidate and to the letter issued by Senator Hale, of Maine, saying that he is withdrawn as an aspirant for reelection.

* * *

SENATOR HALE is the putative and Senator Aldrich the actual leader of the Republicans in the Senate. Hale is leader under the Senate tradition which makes the oldest senator, in point of service, of the majority party, the chairman of the caucus of his party, head of the steering committee and chairman of the Committee on Committees. By virtue of that last position, Hale determines, practically, the make-up of the entire committee list of the upper body; and that means that he controls the color and attitude of the entire organization. Of course, Aldrich and Hale have long divided the powers and the honors of the Republican leadership. The tariff session brought the first real revolt against their domination. They won at all points; but a short year afterward we see them simultaneously withdrawing in the face of bitter opposition at home.

It is difficult to overstate the sensation caused in Washington by the announcement on the same day that these two leaders were to retire. The insurgent Republicans in Maine have been fighting hard for a year to defeat Hale, whose successor will be chosen by the legislature elected the coming autumn. They had made such progress that they were already confidently claiming the victory, when Hale withdrew. Likewise, in Rhode Island, although they knew the Republican gerrymander of the state and the ancient town system of districting gave them no chance, the anti-Aldrich forces were organized and determined that they would cast a big majority of their state's votes against Aldrich, just by way of showing that they wanted to repudiate him, even if they could not actually rid themselves of him. For you must understand that, as Rhode Island is districted, eleven per cent. of the people, distributed among the small country districts, are able to elect a majority of the legislature and determine who shall be the senator, while eighty-nine per cent. of them get no hearing at all.

* * *

THE Hale withdrawal is accepted as sincere. But nobody believes that Aldrich is really out of the Rhode Island race. The expectation is that he will keep his personality out, allow the anti-Aldrich fight to die out and then, after the Republicans have comfortably elected a majority of the next legislature, will become a candidate again "under strong pressure of demand from my friends and fellow-citizens," and be elected to succeed himself.

To have these two Senate leaders retire together, however, is equal almost to the accomplishment of

revolution. Senator Dolliver stated the case literally when, being asked who would "get the mantle of leadership," he replied: "Oh, we are going to take that interesting old garment out, wrap it in moth-balls and consign it to the mercies of a tender oblivion. There will not be any more leadership. The Senate will try running itself and doing its own business."

The Senate after March 4, 1911, is going to be a radically different body. The Republicans will lose a number of members to the Democrats, and the conservative or pro-Aldrich Republicans will lose several more to the radical or progressive faction. After these changes are made, the combination of insurgent Republicans and Democrats will have a comfortable majority. But, of course, when that situation arises, the effort to force united action between the progressive Republicans and the Democrats will be vastly more difficult than in the past.

The marvelous geographic differences between political conditions east and west of the Alleghany Mountains are among the most significant features of the national situation.

East of the Alleghany Mountains the fight is between Democrats and Republicans. There is no effective, organized insurgent Republican fight for control within the party. Disaffected Republicans, with no apparent hope of wresting control of their own party from the old organizations, quietly vote with the Democrats, as they did in the Massachusetts district which elected Foss, and in the New York district which elected Havens. That is what they are going to do the coming fall all through New England, New York, Pennsylvania, New Jersey, Delaware and for the greater part, according to advices, in Ohio. On the other hand, in Indiana, Wisconsin and the states west of there, the insurgent Republicans will fight for control within their party, and where they are able to control the nominations, will secure a vast number of votes from liberal Democrats.

In Indiana and the states to the westward the old-line, or "stand-pat," Republicans will for the greater part be the irregulars—the ones who will join with the Democrats, in order to defeat liberal Republicans. East of Indiana the reverse will be true, with thousands of progressive Republicans joining the Democrats to turn out Republicans who are suspected of being too conservative.

Out of it all the Democrats will probably carry the new house. The Republicans will gain a considerable number of insurgents, of the Norris-Murdock-Cummins-La Follette stripe; and they will lose some regulars of the Cannon persuasion.

* * *

ALREADY the Democrats in the House are quarreling over their own policy in the next Congress. Expecting to get control, they want to make it as effective as possible. There are jealousies and rivalries among various aspirants for the speakership, but Champ Clark, of Missouri, the present leader of the Democrats in the house, seems likely to win the caucus nomination of his party and become the speaker of the House. That will make him a serious presidential possibility, along with Mayor Gaynor, of New York City; Governor Harmon, of Ohio; Governor Marshall, of Indiana, and no doubt Mr. Bryan, whose friends believe he is not yet to be counted entirely out of the situation.

The Republican situation is conceded to depend greatly on what ex-President Roosevelt will do when he comes home. Many Republicans believe it is possible that Roosevelt may run for Congress in the Oyster Bay district, announce himself a candidate for speaker and carry the House for the Republicans with his own personality and popularity. I think it safe to set such suggestions down as pure vaporings. Mr. Roosevelt, according to the best advices, will take very little part in the autumn campaign. He has friends on both sides of the Republican factional line; and he left America last spring a good deal displeased with the treatment that had been accorded to him by President Taft. Of that there is now no doubt whatever. Mr. Roosevelt is a strong party man and whatever he does will be done with the interest of his party in mind; but the interest of Mr. Roosevelt as a possible President from 1913 to 1917 will also be kept in the consideration, and it need be no surprise if the Macedonian call goes up to Roosevelt for help in the autumn campaign, and brings very feeble and ineffectual response.

Page County Ideal for Its Rural Schools

By Jessie Field, County Superintendent of Schools

I GREW up on a farm and attended country school until my teacher told me one spring morning that she thought I had learned all I could there and advised me to go on to high school. So that night after supper I said to my father, "Teacher says I've learned all I can in the country school. Won't you let me start to high school?" My father looked up from his paper at his little brown-eyed tomboy of a daughter and laughed heartily, saying, "Why, yes, start to-morrow." To him the very idea that his girl had learned already all there was to be learned in the country school—of which, by the way, he had been director for years and years—was a good joke. I believe now that it was.

But he had told me I could start to town school in the morning and, in all seriousness, I took him at his word. Bright and early in the morning I was up getting my feet into unaccustomed shoes and stockings and trying to make my cropped hair stay parted in the middle, instead of on the side as I had been accustomed to wearing it, for, you see, it was a very strange and wonderful event to venture into this unknown world—the town high school. I think mother understood and was glad that I wanted to go on, for she did not laugh, she only said, "Andrew is going to town this morning with a load of cobs. You could ride with him if you are ready." So, with my pink sunbonnet tied securely—very securely, so that it would not pull off and hang down my back as it always wanted to do—and my dinner-pail in hand, I climbed onto the load of cobs and, on reaching town, braved the superintendent's office and came home that night fairly launched on the sea of high-school life.

I walked the two miles to town usually, often stopping at the corner near the country school. Sometimes to wish very much that I was back there. Sometimes to help my small brother fight his battles, for I always thought the big boys "picked on him." After I was past this corner I breathed a sigh of relief, happy to be once more in the country. I would skip over the hills to the dear "Sunnyside Farm" with its silver-leaved maple trees. And I would wish that one never learned so much that they had to leave the beautiful country and go to town school. And my father—the fun always twinkled in his eyes over my starting to high school, until I brought home a card that said I ranked first in my big class. After that they still twinkled, but in a different way.

I earned my own way through college, stopping to teach country school for part of it, when I was old enough. But when I graduated from college, the larger salaries offered in city work attracted me, so I took up high-school work and later became principal of a school in the West. From there I was called back by the people to help with the schools of Page County in Iowa.

I tell you this so that you may know me better and so understand why I am so anxious that the country boy and girl should have a "square deal" in school matters. Why, I believe that every country boy and girl is entitled to a chance for an education at least equal to that offered to any child in our land. I was a country girl. I loved the country. I am proud to be a country woman now. I believe in country people. I believe in country boys and girls. I believe in country schools. I believe your boy and your girl can make no better decision for future usefulness and happiness than to decide to stay on the farm and, with high ideals of living and intelligent methods of agriculture, to develop all its great possibilities.

So much for what I believe. This story is to tell you how teachers, people and superintendent have put this belief into practice, with the hope that it may bring better opportunities to other country boys and girls. I will tell you what we have done to make our school houses and grounds more attractive, pleasant and healthful. How we have been able to secure teachers who believe in the country—teachers who refuse town positions in order to stay by their country schools. Last, I will tell you what things we are teaching in our country schools that relate to the farm and the real, home life of the boys and girls. And these things we have done will all be things that are practical, inexpensive and which can easily be done in any country school in America.

Coming from city work in the West where there are modern buildings of beautiful architecture, sanitary precautions of every kind and the best equipments, the first thing that struck me when visiting the schools in Page County was that the school buildings and grounds would be much better if the country boys and girls were to have a "square deal."

There were school-grounds without trees, without fences; school-houses without paint. Sometimes there were holes in the foundation, dingy walls and other signs of neglect. Yet the ground in the school-house yard was fertile—for the weeds found no trouble in growing—and there was every possibility of making beautiful things grow there. And everybody knows that to keep buildings painted and in repair is cheaper than to let them run down. I know that's true. I've watched as I traveled around my county and it never fails. Good corn crops, a big bank account and a beautiful well-kept home go together. Poor crops, mortgages and tumble-down, unpainted, neglected buildings are inseparable.

One of my first investments was a good camera. The trouble was that the people were so used to seeing the tumble-down fences, the unpainted school-houses and all the rest that they really didn't notice it. Some good photographs showing contrasts would help them see. Pictures of neat school-houses and of the "shiftless" kind; of school-grounds with trees and without; of coal-houses

A story of vital interest to parents and teachers, telling how to give country boys and girls a square deal in education and, by so doing, to create in them a love for the best place in the world—the farm.



For the sake of a country child



Starting a garden on a country school-ground



Room for a playground where the children make merry



A class of boys eagerly watching the progress of a tulip-bed

well built and poorly built; of well-equipped school interiors and the opposite, were published in the local papers.

Always for the views of good conditions the name of the school was given and appreciative recognition of the work of teacher, parents and directors given. The pictures of poor conditions were never labeled as to their locality—but somehow the people to whom they belonged invariably seemed to recognize them. So the camera, with the help of the local press, has been a good missionary and never failed to secure results. This line of work has been strengthened this year by adding a portable stereopticon to the equipment of the office.

Arbor Day has been set aside as a day for real work. Schools organize for this. The day is spent in carrying away cinder-piles, raking the yard, planting seeds, vines and shrubbery, and thoroughly scrubbing and cleaning the house. The work of the day is reported to me by the children of the school. Usually some recognition of the work done is sent out—bulbs or seeds or shrubbery obtained from local nurserymen or seedsmen.

The following is a report sent in by a pupil:

Arbor Day at Fairview

At nine o'clock on Friday our teacher, Mrs. Rilla Waugh, and her seventeen scholars met at Fairview, surrounded with small trees, bushes, vines, flower-seed, garden-seed, wash-rags, pails, brooms, hoes and rakes, to see what we could do to celebrate Arbor Day on that bright, sunny, cool morning.

The first thing we did was to plant the trees, bushes and plants so that they would not wilt. Then we cleaned the yard, raked it and swept it nicely. Afterward we made flower beds and gardens. The flowers we planted were pinks, Johnny-jump-ups, asters, marigolds, poppies, peonies, sweet peas, blue and yellow flags, bridal wreath, two or three lilac-bushes, fifteen rose-bushes, a snowball-bush and live-forever. We also started three house plants—a feverfew, some English violets and a begonia.

We then set out wild cucumber-vines so they would climb over the outbuildings. One flower-bed was made with a brick border, the other two being made of planks. The two gardens were planted with corn, onions, lettuce, radishes, strawberry and raspberry plants.

We did not plant so very many trees this year, only two plum-trees and four peach-trees, for there are ninety-four large trees on our grounds now.

Many years ago, when the country was new, Hon. S. E. Field set out all these except two, and now Mrs. Waugh teaches the children to have much respect and gratitude to him for this kind act.

After our refuse was all burned and everything finished outdoors, we went into the school-house and cleaned it up nicely. We washed the woodwork, pictures and desks. Our stove came in for a share of improvement and wears a shining black face.

After scrubbing our floors, outbuildings and sidewalks and seeing to all the small things, we went home very tired, but we had all done our best for our school on that lovely spring day.

Every year, also, a report is made by the teacher of the permanent improvements made by the school. Three county meetings of school directors and officers have been held to discuss school problems and have been very well attended.

When we make improvements, we make them as good and as permanent as possible. We believe in cement walks; the best jacketed stoves or, better still, a furnace; strong, durable woven-wire fence on three sides and posts with cable or gas-pipe in front, and the posts painted. Inside, the best and most up-to-date maps; slate blackboard; the latest edition of an international dictionary, calcimined walls or, if they have already been papered, some plain attractive wall-paper; single seats of the strongest construction; sectional bookcases that can be added to from time to time as the library grows, filled with only good, wholesome books; a porcelain sink or bowl with a drain-pipe leading outdoors and a drinking-tank with individual drinking-cups. Not one of these things can a country school afford to be without. They will not only be money-savers, but will make your school mean more to your boy and girl, make them care more for school property and for the country, bring to you better teachers and be a source of pride for the entire community.

We have had considerable success with Dutch bulb gardens on our country school-grounds. They grow easily and blossom before any of the schools close. One fall I distributed six thousand tulip bulbs among the schools. The children planted and cared for them, and the next spring the blossoms were rapturously enjoyed by them. I had hardly realized that children could love flowers so well.

One spring morning as I drove up to one of my schools the children greeted me with, "You'll think we have a pretty tulip-bed." "Come and see our tulips." And surrounded by teacher and pupils I was hurried to see them. They were beautiful, a gold and crimson mass of blossoms.

In this school is a boy in whom I am much interested. His mother died when he was a little fellow, and his father is a rough coal-miner. The boy is the natural product of such surroundings. He would swear like a trooper and had used tobacco since he could remember. When his teacher, after having talked to him about the sin of swearing, found him at it again, she said, "Walter, I have talked to you about swearing and it seems you have forgotten again. I think I'll have to whip you for it this time." The boy answered, "I just as soon you'd lick me and lick me hard if it will make me remember

[CONCLUDED ON PAGE 26]

Our Puzzle School

Conducted by Sam Loyd

The Missing Letters

FOR a long time, the pupils of the public school on Main Street have been so intent upon deciphering a broken fence sign, that Mrs. Wiggs, the principal of the school, says the puzzle must



be guessed, the fence removed or the school closed. Can our puzzlists tell what letters were painted upon the broken boards?

Of course, it has no connection with the puzzle, but our readers will remember that the fence was demolished by the accident to the fire chief's automobile over a year ago.

Deeply Injured

Her eyes were wild, her hair was in disorder, her face was flushed, her hands were clenched. She was a deeply injured, desperate woman.

"Oh, cruel one," she cried, in anguished tones, "I have borne with you too long! You have injured the very foundations of my being. Day by day you have tortured me, and yet I could not bear to give you up. When first we met, how your ease and polish attracted me! When you became my own, how many friends envied me! Yet your understanding is too small for my large soul. You are opposed to my advancing myself. You have ruined my standing in society. If we had never met, I might have walked in peace. So begone. We part forever."

There was a moment's convulsive breathing, a gritting of teeth and a sharp sigh. It was all over. By a supreme effort she had removed her —?

Concealed Geography

In the following sentences the name of some town or country is concealed between two words. Can you guess the answers?

54. They have nice sweet potatoes at Parker's.
55. She looked very trim in India rubber boots.
56. The major, seizing a can of kerosene, gallantly dashed forward. (Country.)
57. Some men would lag at heaven's gate.
58. December lingering chills the lap of May.
59. Do you keep your clothes in the attic or in the cellar?
60. He ran down the street with the mob at his heels.
61. If you would make your lawns symmetrical, cut tall trees off and leave the short ones.
62. He rode a camel bare-back through the city, to the consternation of the people. (An island.)
63. In Milan singers of note love to congregate.
64. The animal taken was all cut and bruised. (An island.)
65. A Tartar rag on a Russian flag is the Cossack signal of revolt.
66. An ape ruined my rose-bush. (Country.)
67. Was it a lynx, are you sure of it? (Country.)
68. I never sail lest I should upset.
69. Ten to one I dare do it. (Lake.)

Brain Sharpeners

What would you call a boy who eats all the green melons he can get? He is what we call a pains-taking youngster.
 What is an eavesdropper? An icicle.
 Why is a neglected damsel like a fire that has gone out? Because she has not a spark left.
 Why are bells used to call people to church? Because they have an inspiring influence.
 What is that which goes up the hill and down the hill and yet stands still? The road.
 When is a bill like a gun? When it is presented and discharged.

Poetical Decapitations

Here is an odd little bit of decapitation, where the removal of the first letter, then the second, third and fourth in the three missing words makes the meaning clear:

The lilies on the bank are —,
 While in our little bark we're —,
 Our course to favoring breezes —,
 Like birds upon the —.

With lily-pads the oars are —,
 As eager hands the blossoms —;
 Each shouts, "Dull care away —,"
 And echo answers, "—."

It seems to me a strange —,
 That we should pay so great —,
 For trifles like a little —,
 Or such a common thing as —!

A Clever Cutting Puzzle

Checkers is almost a national game among the Scottish people, who devote as much time to it as others do to bridge or whist. A party of excursionists from Glasgow got caught on a train without a checker-board, so they gave "saxpence" to a poor woman to allow them to play a few games on a checkered patch on her shawl. It was an odd-shaped patch, as here shown, with two of the squares misplaced:

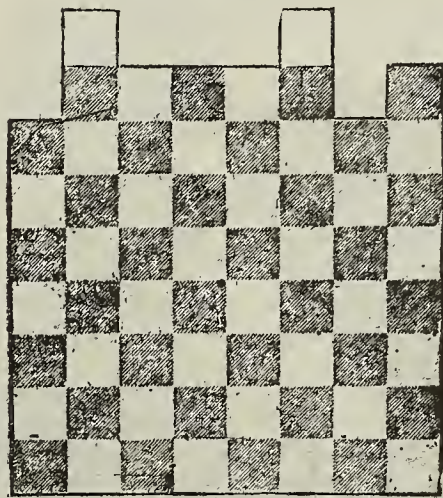

Show how to cut the above irregular form into pieces which will fit together so as to form a perfect eight by eight checker-board.

Speaking of checkers suggests a puzzle which may prove of interest to many of our readers, for it is almost safe to say that every one is possessed of some knowledge of this widely-known puzzle. What is the shortest possible game wherein one player defeats his opponent?

Answers to Puzzles in March 10th Issue

In the apple-woman's puzzle Mrs. Jones lost 21 cents.
 The answer to the rebus is "rail."
 Answers to Evolution Puzzles: Cat to dog: Cat, cot, cog, dog. Boy to man: Boy, bay, ban, man. Wood to coal: Wood, wool, cool, coal. Lion to lamb: Lion, limn, limb, lamb. Hate to love: Hate, have, hove, love. Warm to cold: Warm, worm, word, wold, cold. Fish to meat: Fish, fist, fiat, feat, meat. More to less: More, lore, lose, loss, less. Fire to cold: Fire, fore, core, cord, cold. Ride to walk: Ride, wide, wade, wale, walk.
 Answer to Missing-Word Anagram: A vile old woman on evil bent Put on her veil and away she went. "Levi," she cried, as she went on her way.
 "How are we going to live to-day?"
 Answer to The Hindoo Flower Trick:

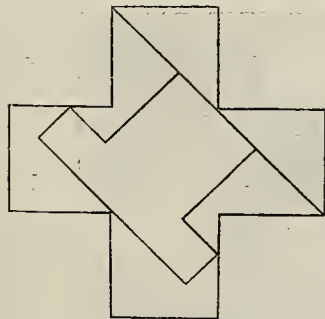

Many correct answers to all of the puzzles were received and prize puzzle books have been mailed to them for their clever work. Fifty books, containing the finest collection of puzzles ever issued, will be distributed among those sending the best answers to Sam Loyd, Box 826, New York City.



LOOK at this—the illustration represents what you can do with Jap-a-lac—a scratched and scarred refrigerator transformed so that it looks like new. Which one does yours look like? You'll be surprised to find how easy it is to

RENEW WITH JAP-A-LAC

REG. U. S. PAT. OFF.

Jap-a-lac can be used on anything of wood or metal from cellar to garret. Made in seventeen beautiful colors, and Natural or clear.



"THE JAP CHAP"

The Jap-a-lac Model Floor Graining Process solves the problem of "What shall I do with my old carpeted floor to make it sanitary and refined?" Your painter can do it at little expense or you can do it yourself. Insist on Jap-a-lac. For sale by Paint, Hardware and Drug Dealers.

Write for illustrated booklet containing interesting information and beautiful color card. Free on request. If your dealer does not keep Jap-a-lac, send us 10c to cover cost of mailing, and we will send a free sample, quarter-pint can of any color (except Gold which is 25c) to any point in the United States.

Our Green Label Line of clear varnishes is the highest quality manufactured. Its use insures perfect results. Ask your paint dealer.

The Glidden Varnish Company

5520 Glidden Bldg., Cleveland, O.

Jap-a-lac is like Uncle Sam's gold certificates, it's the standard.

Don't Throw it Away

Does Your Granite Dish or Hot Water Bag Leak?

USE **MENDETS** PATENT PATCH

They mend all leaks in all utensils—tin, brass, copper, granite, hot water bags, etc. No solder, cement or rivet. Any one can use them; fit any surface; three million in use. Send for sample pkg. 10c. Complete pkg. assorted sizes, 25c postpaid. Agents wanted. Collette Mfg. Co., Box 148, Amsterdam, N. Y.

A FLOOD OF LIGHT FROM KEROSENE (Coal Oil)

Burning common kerosene the ALADDIN MANTLE LAMP generates light that gives a light more brilliant than city gas, gasoline or electricity. Simple, odorless, clean, safe and durable.

AGENTS MAKE BIG MONEY

Is revolutionizing lighting everywhere. Needed in every home. Every lamp guaranteed. Sells itself. Our Sunbeam Burners fit other lamps. Ask our nearest office how you can get a lamp free or apply for Agency Proposition. **THE MANTLE LAMP CO. of America, Desk 414** Chicago, Portland, Ore.; Waterbury, Conn.; Winnipeg, Montreal, Canada.

It is to your advantage to mention Farm and Fireside in writing to advertisers. Farm and Fireside folks get the very best attention.

PATENTS WORTH FORTUNES

Inventors: Send 6 cts. for our Valuable Patent Books R. S. & A. B. Lacey, Dept. 19, Washington, D. C. Est. 1869

PATENTS SECURED OR FREE RETURNED.

Free report as to patentability. Illustrated Guide Book, and List of Inventions Wanted, sent free. **VICTOR J. EVANS & CO., WASHINGTON, D. C.**

As the Flower Tempts the Honey Bee



So Post Toasties

with cream and sugar, tempts the appetite.

Ever taste this crisp, brown appetizing food?

Always ready to serve — always delicious —

"The Memory Lingers"

Popular pkg. 10c; Large Family size 15c.

Postum Cereal Co., Ltd., Battle Creek, Mich.

Young Hustlers

Farm and Fireside Boys and Girls Who Have Won Success



Iona Morton and "Dandy"
Kernersville, N. C.



Leonard Foreman and "Bonny"
Osceola Mills, Pa.



Alf. Erickson and "Beauty"
Stanhope, Iowa

EACH year, for several years, FARM AND FIRESIDE has conducted a Pony Contest for its boy and girl readers. Dozens of ponies, with their outfits, several pianos and thousands of other prizes have been awarded in these contests. The pictures and letters on this page introduce to FARM AND FIRESIDE readers a few of the boys and girls who have been made happy by their success in these contests. Some of the letters, as you will see, are from children who did not win ponies, but who were delighted with the prizes they did receive, for FARM AND FIRESIDE tries to reward fully all its boy and girl hustlers for the time they spend in the contests, even though they do not win ponies. These boys and girls came from all sections of the country.

OUR readers will be especially glad to become acquainted with the faces of some former pony-winners at this time, because the 1910 FARM AND FIRESIDE Pony Contest is just beginning, the Pony Man's first announcement appearing on Page 27 of this issue. As in the past, the prizes will be awarded according to the number of FARM AND FIRESIDE subscriptions secured by each contestant during the term of the contest, which begins with the appearance of this issue and which will close on July 30th. Most every reader will have some young friend entered in the contest, and will want to help the youngster by suggesting the names of people who should subscribe to FARM AND FIRESIDE, as well as by giving his own renewal subscription.

Letters From Our Pony-Winners

DEAR PONY MAN:—

My pony "Bonny," saddle and bridle arrived Thursday evening, and such a crowd of boys and girls as there was to meet him you never saw. I cannot begin to tell you how happy I am in being the owner of such a fine pony. He is a perfect beauty and everyone that sees him likes him. I certainly have been well paid for the little time I spent in getting subscriptions. It was no trouble at all, every one thinks FARM AND FIRESIDE is a fine paper.

Yours very truly,

LEONARD FOREMAN, Osceola Mills, Pa.

DEAR PONY MAN:—

Inclosed you will find a picture of myself, "Wuzzy" and his cart taken October 5th just after the parade of the Fraternal Order of Eagles. We led the parade and the pony was not afraid of bands or anything else. The pony is a beauty. I have been offered \$200 cash for the pony alone. It was no trouble at all to get subscribers when I told these big-hearted Kentuckians that I represented FARM AND FIRESIDE and that I was working to win a pony. Hardly any one refused to subscribe to the paper. They all seemed to be so glad that I took such an interest in the contest. FARM AND FIRESIDE always do more than they promise.

MARGUERITE LAWSON,
Hopkinsville, Ky.

DEAR PONY EDITOR:—

My pony arrived at Franklinville at 3:20 o'clock to-day. Oh, it is a beauty! There were lots of my friends at the depot and we certainly gave him a royal welcome. There was a man there who is a judge of Shetland ponies and he pronounced "Duke" the best he ever saw. Now, I want to thank you for the fair treatment I received from FARM AND FIRESIDE. Some people told me I would not get a pony, and he was a fake, etc., but I kept on working and now I have my reward.

DOROTHY A. MILLER, Franklinville, Ohio.



Marguerite Lawson and "Wuzzy"
Hopkinsville, Ky.

Talking-Machines and Other Prizes

DEAR PONY MAN:—

FARM AND FIRESIDE certainly did more than they agreed to. Instead of sending me a fifty-dollar Victor Talking-Machine they sent a seventy-five-dollar Columbia, and instead of six records which my prize called for, they sent me ten. For other contestants, I can say that it takes a little hustling. Do not get discouraged and don't stop until the last minute, and I know FARM AND FIRESIDE will do all they can for you.

Yours very truly,
MARIUS RITER, Paterson, N. J.

DEAR PONY MAN:—

I received my bicycle safely and it certainly is fine. I am learning to ride it now. I am very pleased with it and ever so much obliged to you for your kindness. As ever your little friend,

ELLEN M. LOVE, Dayton, Ohio.

DEAR PONY MAN:—

I was very much surprised to learn that I was so fortunate as to be a Grand-Prize winner in FARM AND FIRESIDE Pony Contest. I would have secured more subscriptions, but sickness in family prevented. The sewing-machine you sent me is simply beautiful and I could not possibly be more pleased than when I received it. It was not difficult to get subscriptions and every one I heard speak of FARM AND FIRESIDE thinks it a splendid paper.

Thanking you, I remain respectfully yours,
H. J. JARVIS, R. F. D. 2, Delaware, Ohio.

DEAR PONY MAN:—

The Music-Box I won in the Pony Contest is a beauty in every respect and is a joy forever to us all. You certainly treated me nicely and I am going to try and win a pony the next time you have a contest.

Your little friend,
HOLLAND B. ALEXANDER, Dixon Springs, Tenn.

More Letters From Farm and Fireside Pony-Winners



Orrin E. Hill
Kennedy, N. Y.



Helen Owings
Briceville, Tenn.



Herman Morton
Kernersville, N. C.

DEAR PONY MAN:—

I received my pony and the four-wheeled cart with harness all in good condition, and I cannot express myself in words, how grateful I am to you. The pony is a little dandy, and as pretty and gentle as you find anywhere, and the cart and harness are far above my expectations and far better than you advertised them to be, so you have certainly done as you agreed to, and a whole lot more.

It is as easy as falling off a log to get subscribers for FARM AND FIRESIDE after seeing the quality of the paper, and then get busy. If I had had a little more time. I could easily have gotten first prize, but am more than satisfied with the second. Every one who has seen the outfit (and they are quite a few) says it is the handsomest rig they ever saw, and that is certainly speaking well for you. I wish if you have another contest, that I could get into the race again, but wish you and all the contestants good luck in all your undertakings. Now I wish to express my most heartfelt thanks to you for your honesty and fair treatment.

Ever your friend,
ALF. ERICKSON,
R. R. No. 2, Stanhope, Iowa.

In the spring of 1908 Herman Morton won "Billy," the second-prize pony, and the following year, 1909, his sister Iona entered the pony contest and won "Dandy," the first prize, so that this brother and sister now have a team. Here are some of their letters. Herman wrote:

DEAR PONY MAN:—

I can't begin to tell you how happy I am in being the possessor of such a fine pony, cart and harness as you sent me. If I had started to get subscribers when the contest first opened, I believe I



Dorothy Miller and "Duke," Franklinville, Ohio



LaVerne Fulton and "Cupid," North Lawrence, Ohio

would have won first prize, but I couldn't wish a finer pony than "Billy." I wish I could enter another contest and win another pony, but I suppose I can't because I have won one already!

HERMAN MORTON, Kernersville, N. C.

Iona received her trap and harness before her pony "Dandy" arrived, and wrote on July 7, 1909:

MY DEAR PONY MAN:—

The little trap came yesterday and I must write you and thank you so much for it. Papa put it up for me. I do hope "Dandy" will be as fine as "Billy." Billy is fat and slick, and after "Dandy" stays here a while he will be fat, too. Herman sends his love to the Pony Man. Mother and father send their regards to you also.

Your little friend,
IONA MORTON, Kernersville, N. C.

A little later, after she received "Dandy" Iona wrote:

"In saying what pleasure I derive from my pretty pony "Dandy," is putting it mildly indeed. I think he is rightly named. I don't believe there ever was a prettier pony. IONA MORTON, Kernersville, N. C.

DEAR PONY MAN:—

"Prince" is a beauty. I would not part with him for any price. He had hardly reached here before all the boys in the neighborhood were on hand to see him. I surely have been more than paid for what I have done for you. I found it very easy to get subscriptions to FARM AND FIRESIDE. People were anxious to take it. I tried the half-work and half-play plan last year. This time I cut out the play and hustled—and I won. Any one can win if he hustles. Your friend,
HOWARD G. LAIDLAW,
Walton, N. Y.



Myrtle Markley
Raspeburg, Md.



Howard Laidlaw
Walton, N. Y.



Florence Boyer
Meyersdale, Pa.

A Revolutionary Dress Silk Offer from New York

"From the Silk Mills Direct to You"

ROYAL SILKS

WE give the retailer's profit on dress silks to you instead of to him. Do you realize that this is from 40% to 50% of the wholesale price? Send us 25c and tell us what kind of gown you are thinking of—evening, street, dinner, or any other use you have for excellent, pure silks and we will immediately send you samples and prices—generous samples from which you can judge weight, texture and color. The 25c will be applied on your first order; or we will immediately return it to you if you return the samples to us.

We absolutely guarantee satisfaction to all customers.

ROYAL SILK MILLS COMPANY, Dept. F, Retail Salesrooms, 47 West 34th St., New York (Mills at Plainfield, N. J.)

Bargains in Magazines

A Wonderful Chance to Get Farm Papers at Reduced Rates

We will send FARM AND FIRESIDE and your choice of any one of the following papers for only 50 Cents. They may go to one or separate addresses.

- Paris Modes (with pattern)
- Woman's World
- Poultry Keeper
- Green's Fruit Grower
- Missouri Valley Farmer
- Up-to-Date Farming
- Poultry Standard
- Farm Poultry
- Southern Planter
- The Housewife
- Farmer's Voice
- Farm Life

Any One With Farm and Fireside

50 Cents

Send all orders to

FARM AND FIRESIDE, Springfield, Ohio

ANCHOR FENCE
means fence satisfaction. A fence easy to put up, that is made right and that lasts. Free Sample and Catalog.

LAWN FENCE
Many designs. Cheap as wood. 32 page Catalogue free. Special Prices to Churches and Cemeteries. Coiled Spring Fence Co., Box 403 Winchester Ind.

Ornamental Fence
Cheaper than wood for churches, Public Grounds. Also Wrought Iron Fence. Catalogue free. Write for Special Offer. THE WARD FENCE CO., Box 176, Decatur, Ind.

ORNAMENTAL FENCE
25 DESIGNS, ALL STEEL Handsome, cheaper than wood, more durable. Special prices to churches and cemeteries. Don't buy a fence until you get our free catalog. Kokoro Fence Machine Co., 427 North St., Kokomo, Ind.

MEMORIALS & MONUMENTS
FOR CEMETERIES SCHOOLS & PARKS
LARGE VARIETY OF DESIGNS FOR EVERY PURPOSE. DELIVERED ANYWHERE. SEND FOR CATALOGS. STATE REQUIREMENTS. AGENTS WANTED. MONUMENTAL BRONZE CO., 347 HOWARD AVE., BRIDGEPORT CONN.

\$5 a Day Easy
One good man in each town wanted (spare time or all time) to take orders for our made-to-measure clothes. Up-to-date styles, very low prices; orders come easy. High-class permanent business, splendid profits. No money or experience needed. We ship on approval, express prepaid and guarantee perfect fit. Write quick and we will send you samples and agent's outfit free explain everything and make a special inside price on a suit for yourself. It's a wonderful opportunity. Banner Tailoring Co., Dept. 411 Chicago

EARN WATCH RING and CHAIN
BY SELLING 18 CARDS of 10c. ART JEWELRY WE GIVE a plated GOLD WATCH like years, (together with chain), also imitation DIAMOND RING having two sets for selling 18 cards of jewelry at 10c each. LADIES' size WATCH for selling 24. Order jewelry—sell it—send pay—get premiums. L. F. Spencer, Horton, N. Y.

EARN Watch, Ring and CHAIN
FOR SELLING POST CARDS
We positively give both a Famous Alton Watch, Stem Wind, handsomely designed case, American movement, factory tested, guaranteed five years, also a nice Ring set with a Congo Gem, sparkling and fiery, for selling 20 packages beautiful high grade Art Post Cards at 10c per package. Order 20 packages, when sold send \$2 and we will positively send you the watch, ring & chain. Satisfaction guaranteed. ALTON WATCH CO., Dept. 481, CHICAGO

Ladies & Gents Watches GIVEN
We give all grades of Watches for selling our fine Art Post Cards at 10c per pkg. Order 20 pkgs. today. When sold, send us the \$2.00 and we will send you an elegant 5 YEAR GUARANTEED WATCH, also a FINE SIGNET RING and a CHAIN, postpaid, as per our premium list. IT COSTS YOU NOTHING. Write us today. BELMONT MFG. CO., Dept. 90, CHICAGO

\$10,000 FOR A SONG RECENTLY PAID
Send me your song poems for examination and offer. H. KIRKUS DUGDALE, Dept. 107, Washington, D. C.

AGENTS WANTED
Men or Women to sell Consumers. Big Profits. Groceries, Coffees, Teas, Extracts, Perfumes, Soaps, etc. With or without premiums. Write for catalogue A. Bushway Flavoring Extract Co., 951 N. Water St., Decatur, Ill.

PATENTS
Inventors Books free. Trade-marks registered. BEELER & ROBB, 22-26 McGill Bldg., Washington, D.C.

PATENT YOUR IDEAS. They may bring you wealth. 64-page Patent Book Free. Fitzgerald & Co., Attys., Box N, Washington, D. C. Est. 1839

20 Post Cards 10c
Decorated Day, 4th of July, Birthday, Floral, Best of all. All different. Best value. Lovely colors. No trash. STAR POST CARD COMPANY, 144 S. 8th Street, Philadelphia.

SUNDAY READING

When God Helps

By Rev. Charles F. Weedon

HE HELPS when we help ourselves. God always requires that we do our part. We forget that. Help implies the cooperation of two or more. When the shepherd lad went out to fight Goliath, he chose five smooth stones from the dry bed of the brook. Then he ran to meet his boastful foe. God gave the young warrior a clear eye, a cool nerve, a steady arm and, whirling his sling, he sent the stone hurtling into the Philistine's head. David did his part. God and David killed the giant. So of the Master at Lazarus' grave. "Roll ye away the stone!" That was man's part. "Lazarus, come forth!" That was God's part. "Heaven helps those who help themselves."

God helps us when we are intimate with Him. Marching through the wilderness of Shin, the pillar of fire was bright to the Israelites, but to the Egyptians unintelligible darkness. The latter were not acquainted with Jehovah. We must know the spiritual alphabet that we may learn to spell out God's meaning. Here is a little child who stumbles before you on the walk. He only cries more lustily when you try to comfort him. But along hastens the mother, catches the little one in her arms, lays his head gently upon her shoulder, strokes the soft curls and throbbing temples, calls him all the pet names that mother and child know together so well, until gradually the sobs grow fainter and fainter and at length a shy, sweet April face smiles up through the tears at the mother. The mother understands the child, the child is on intimate terms with the mother and can receive her help. To be in close relationship with God gains His help. "As one whom his mother comforteth so will I comfort you."

Does God pay attention to our prayers? Pray definitely and try Him. Let the school boy or girl pray over a vexed lesson, a merchant over the investments of his money, the farmer about his crops and lands, the housewife, wearied over nine hundred and ninety-nine things that a man doesn't know anything about, let her ask for patience and wisdom.

What a privilege to carry Everything to God in prayer.

One of the most comforting sayings of Jesus are the words: "Come unto me, all ye that labor and are heavy laden, and I will give you rest." But do we always get rest? Under proper conditions, yes.

A woman who resided in my vicinity was stricken with disease. No one for a time went near her, and when at length some church friends called, they expected to find her morose and complaining. Instead, she was cheerful and happy. Somewhat perplexed, the women asked the reason for her contentment. Holding up one finger straight, she said: "Do you see that? That was God's will." Placing the forefinger of her other hand across the first uplifted finger she said: "That was my will. Then I had a cross." Her face brightened into a beautiful smile as she raised both hands and placed one finger beside the other, saying, "My will lies right along side of God's will and I have no cross to bear now." "Oh," cried Miss Havergal, "if we only knew the joy of an accepted sorrow."

God helps us when we keep in the line of our duty. Just humdrum, plodding duty. In Longfellow's legend beautiful you remember a monk, while contemplating Holy Writ, sees a wonderful vision. While he is joyfully gazing upon it, the bell of the monastery rings, a signal for him to feed the poor at the gate. He hesitates. Should he leave the vision? Then conscience spoke:

Do thy duty, that is best, Leave unto thy God the rest.

He performed his menial task and on returning expected to find only the bare walls of his cell, but to his surprise the vision was still there more radiant than before. It was a vision of the Christ, and the lips seemed to part and to say: "Hadst thou stayed, I must have fled." God can help us when we are faithful at the post of duty.

I know not where His islands lift Their fronded palms in air, I only know I cannot drift Beyond His love and care.

God helps of all by the gift of Christ. He gives us confidence in our last earthly hour. Sometimes the world says: "You Christians seem as afraid to die as any one." Perhaps so. The nerves and body become weak and fagged and we may shrink from the final dissolution. But we can afford to admit it. For the Christian answers the challenge with the question, "Have you any hope in death?" This is the believer's comfort, "The righteous hath hope in his death." As he nears the dark waters he hears the familiar words: "When thou passest through the waters I will be with thee and through the rivers they shall not overflow thee." Christ helps us by His sympathy, gentleness, strength, promises and love. He is not a far-off Zeus upon some cold-peaked Olympus, but near us and made real as a man of flesh and blood. The name Jesus means Savior. He charts our course, planting a lighthouse here, a beacon yonder, a buoy where the rocks and shoals hide and where the treacherous undercurrents run. He is the Great Captain and Elder Brother. Does the lane seem long and the time endless and the evil of the world bold and successful?

Truth forever on the scaffold Wrong forever on the throne, But that scaffold sways the future And behind the dim unknown Standeth God within the shadow Keeping watch above his own.

My friend, if you are disheartened, take courage. The Lord of Hosts is with us. The God of Jacob is our refuge.

Listen for the Beautiful

AN AMUSING story is told of the late Miss Ingelow, the poet. She was spending some time in the country with some friends, when she remarked in her conversation that although she had often written about nightingales, she had never heard one sing. One beautiful moonlight night her friends took her out to the meadows where the famous singers were pouring out their sweet music. After waiting for some little time, Miss Ingelow asked, "Are they singing?" Then it was learned that the poetess had a dread of drafts and before going out had stuffed her ears full of cotton. So it is with many of us, we have our ears stuffed with so many other things we fail to hear the beautiful and the good; and some of us have our ears open for the bad and closed to the good. "He that hath ears to hear let him hear."

A Pure Heart

It is surprising to look into the Word of God and see how much is said about the human heart. It seems that all the Scripture deals more or less with the heart. In fact Christianity is the only religion that does deal with the heart in its teachings. It insists on having the heart and having it clean and pure. The physical heart is the seat of physical life, it is the great central organ from which flows human life, but the heart spoken of in the Word of God is the spiritual heart, the seat of the affections and the center of spiritual life, from which flows our moral or immoral acts and deeds. A recent moralist has affirmed that the human heart is like a jug: "No mortal can look into its recesses, and we can only judge of its purity by what comes out of it." Christ said, "Blessed are the pure in heart, for they shall see God."

Keep Close to Things Heavenly

In an old art palace in Germany there is a painting called "The Clouds." When you first come up to the canvas it looks like big daubs of paint thrown here and there on it in a careless way; but get up a little nearer and you begin to see the outlines of characters. Come still nearer and fix your eyes upon the canvas, and faces begin to appear, then while you are intent on looking at the old painting there appears innumerable angels floating in a sea of clouds. So it is with us when we first begin to draw near heavenly things. At first they may seem so vague and far off that it is hard to understand, but the nearer we get to heaven the more of its beauty we will see.

The First Mistake

EUGENE C. DOLSON

Could each his first wrong step foresee, The danger would be less; The truant from the school may be The exile from success.

SIMPSON REG. U.S. PAT. OFF. EDDYSTONE FOUNDED 1842

Reputation
Over sixty-five years' reputation is back of every yard of Simpson-Eddystone Silver-Grey Prints

These exceptional calicoes are widely used for cotton dresses because of their fast color, pretty designs and enduring quality of cloth.

If your dealer hasn't Simpson-Eddystone Prints write us his name. We'll help him supply you. The Eddystone Mfg. Co., Phila., Pa. Established by Wm. Simpson, Sr.

How often do you eat this food?

A short time ago there appeared in the columns of one of the prominent magazines an article on building brain and muscle by the proper selection of the foods you eat.

A good many people were surprised to find oatmeal placed at the top of the list of foods recommended; but if the article had appeared in an English or Scotch paper every reader would have expected to see first place given to good oatmeal.

As a matter of fact Great Britain and Europe come to us for tremendous quantities of Quaker Oats because it represents to them perfect food, being the richest in flavor and best in cleanliness and purity, of all oatmeals.

Americans should eat more Quaker Oats; the results would soon show themselves in improved conditions of health and strength.

FREE Beautiful Organ Book
Shows organs in natural colors of the wood. Tells about the finest and sweetest toned organs made. Send me your name and address and I will send you this book and write you full particulars. Send organs anywhere in the United States on free trial and have hundreds of satisfied customers in all parts of the country. I sell Direct from Factory On Easy Terms

—less than ten cents a day will pay for a Purcell organ. My direct price beats them all—saves you jobbers' and dealers' profits. Don't decide until you get my proposition. I. S. PURCELL, Factory to Home Piano and Organ Man 18 Western Ave., Chicago, Ill.

FAMILY FOOD Crisp, Toothsome and Requires no Cooking

A little boy down in N. C. asked his mother to write an account of how Grape-Nuts food had helped their family.

She says Grape-Nuts was first brought to her attention in Charlotte, where she visited.

"While I was there I used the food regularly. I gained about 15 pounds and felt so well that when I returned home I began using Grape-Nuts in the family regularly.

"My little 18-months-old baby shortly after being weaned was very ill with dyspepsia and teething. She was sick nine weeks and we tried everything. She became so emaciated that it was painful to handle her and we thought we were going to lose her. One day a happy thought urged me to try Grape-Nuts soaked in a little warm milk.

"Well, it worked like a charm and she began taking it regularly and improvement set in at once. She is now getting well and round and fat as fast as possible and on Grape-Nuts.

"Sometime ago several of the family were stricken with La Grippe at the same time, and during the worst stages we could not relish anything in the shape of food but Grape-Nuts and oranges, everything else nauseating us.

"We all appreciate what your famous food has done for our family." Read "The Road to Wellville," found in pkgs. "There's a Reason."

Ever read the above letter? A new one appears from time to time. They are genuine, true, and full of human interest.

Disappointing Daisy's Prince

By James Raymond Perry

Illustrated by C. F. Neagle

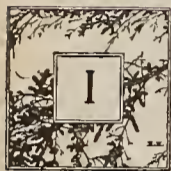

AM GOING driving, Max; do you want to go?" Daisy asked me one day. I told her I should be delighted. I thought perhaps she would have Dolly hitched up, and we would have a comfortable and pleasant drive. Dolly is a gentle and lovable creature, and though she has no special affection for me—none of her tribe has—on the other hand, she has nothing in particular against me. She wouldn't go out of her way to make trouble for me as Prince would. Prince would go miles out of his way—gleefully, enthusiastically, go out of his way—to do me an injury. You see, the beast regarded me as a sort of rival in the affections of Daisy.

I sighed inwardly when I saw that it was to be Prince, but outwardly evinced no concern. At least I tried not to.

"Would you rather drive?" Daisy asked.

"Oh, no," I said, "I know that half the pleasure for you is in driving."

Daisy smiled. "But you're my guest and I ought to be willing to sacrifice my own pleasure if it would contribute to yours."

"Don't worry," I said a trifle shortly, perceiving her drift. I heard Prince chuckling. You might have said 'twas a cough, but it wasn't; it was a chuckle.

When Daisy Held the Reins

We went down the smooth road at a smart pace, Daisy sitting trimly erect, a perfect understanding between her, the reins and Prince.

For me it was a mixture of exhilaration and humiliation. I knew that I should have wanted to drive and I knew Daisy knew it. This, then, was the humiliation; the exhilaration lay in the whirling motion—whatever other faults Prince had, slowness was not one of them—of our light buggy over the gravel road, with that self-possessed trim little figure daintily touching the outer side of my right coat-sleeve.

At the end of a mile there was a little brighter sparkle in her eyes, a little deeper rose in her cheeks. "Isn't he splendid?" she asked, ever so caressingly manipulating a rein in the deft dislodgment of a fly from Prince's flank.

"Fine!" I said, rather less grudgingly than you would imagine. With Daisy driving it certainly was a pleasant experience. She is a most accomplished horsewoman and I felt the utmost confidence in her ability to handle Prince. In fact, it was my conviction that in her case ability was not needed—though she undoubtedly possessed it. Prince would have done anything she wished, he was that fond of her.

"Just look at all that lovely goldenrod!" Daisy cried, "I must gather some to take home. Hold the reins, please!" and she had cramped the wheel and was out on the roadside before I could offer to gather it for her.

Never especially fond of gathering goldenrod I have ever regarded the occupation with vastly more favor than sitting in a buggy holding the ribbons over the back of a spirited horse and waiting for the inevitable exhibition of its known animosity toward me. Moreover, it was fly-time. Cordially loathing myself for cravenly attempting any sort of compromise with my hated foe, I nevertheless began some clumsy efforts to relieve him of sundry clinging tormentors that had promptly fastened themselves on his hide the moment we halted. Prince stomped first one foot and then another, and switched his tail with great vigor. Then, noting the effects of my amateurish efforts with the reins, he glanced around at me in disgusted surprise. "If you think I'm going to accept any assistance from you—" the look said. Then he began to back, the cramped wheel grating ominously.

He paused a moment, not because he was hesitating at all in his preconceived intention, nor, as you might imagine, for the decent purpose of giving me a chance to show what I knew about handling a horse under such circumstances, but merely to prolong the sickening apprehension which he had calculated to a nicety his actions would arouse in me.

Now though Daisy is a mere slip of a girl, barely eighteen, and I am a man grown—if I am ever going to be—nevertheless she is very much accustomed to horses and I am very much unaccustomed to them; so for these reasons I hoped that she would heed the ominous grating of the cramped wheel and decide that she had plucked enough goldenrod. But she continued to gather the plummy sprays of gold oblivious, apparently, to the impending tragedy.

The Hero at a Disadvantage

Then Prince, after a soft snicker—it seemed a mighty fine joke to him, I suppose—began stealthily

but steadily backing again, the cramped wheel slowly but surely guiding the buggy out of the roadway into the gutter. The vehicle was already tilted disagreeably. I knew exactly what Prince intended to do, without his telling me. He intended to back clear around till he was headed the opposite way and then make a spectacular dash for home. He knew he could fix it up with Daisy afterward and that I would get all the blame, anyway. If on the race back he could manage to overturn the buggy and spill me and my brains along the roadside, so much the better. Nothing would please him more. I knew all this as well as if he had gone before a notary public and made affidavit to it. I knew, furthermore, that if I attempted to circumvent him in his purpose by using the whip or slapping the reins over him, he would start off at the same spectacular gait in the direction he was headed. It would make no particular difference to him which direction he took. I had been in a similar situation at least three times before during my career, and on each occasion the beasts had acted precisely in the manner here indicated.

"Daisy!" I called.

She looked around, a great mass of swaying gold in her arms. "Whoa! Prince; whoa! boy!" she called, coming unconcernedly back into the road. She went up to the brute's head and patted his neck and nose and told him he was a nice old boy. (Nice old boy, indeed!) Then she led him up into the road again and came and climbed into the buggy after handing me the goldenrod.

"We'll go back now," she said rather coldly. Gathering up the reins—which I handed over to her with unmixed relief—she steered Prince round on the narrow road in a manner to make one sick with envy and started briskly back the way we had come. Due to the fact that an eighteen-year-old girl had known what to do and how to do it, my neck was still safe and in good working order. But I felt that its present immunity from peril had been purchased at an exorbitant price. Daisy's respect for me and my respect for myself had constituted a portion of the price paid.

"I wish I'd let him run away and break my neck as he'd planned," I reflected miserably, when I saw that Daisy had not been deceived. She said nothing. But I knew, and she knew, and Prince—the cunning and culpable cause of it all—knew that I had been scared. He was delighted—his debonaire manner showed it—Daisy was coldly disapproving, and I was crushed and quite miserable. So we came back to the house, all of us silent, except that unmannerly beast of a Prince who snickered and coughed more than once on the way.

It Doesn't Pay to Sulk

Of course, I sulked the rest of the day, as persons will who have behaved badly, and Daisy was so very busy with her own affairs she had no time to talk to me. However, the sun rose the next morning in quite its usual manner, and under its cheering influence it occurred to me that sulking never did any one any good and that your face felt better when you smiled. So I cracked a joke or two with Daisy's mother, who came out on the piazza to sit with me, and didn't pay any particular attention to Daisy, except to give her a cheerful smile as she passed me on her way down to the gate. Prince stood there hitched to the buggy, and Daisy offered him an apple. It was a rosy and very good-looking apple, indeed—rather better than you commonly give to a horse, it struck me. Daisy had taken a bite from it first, and then held it up to Prince's mouth. I reflected that I should have found such a big rosy apple under such circumstances extremely delicious. But I was not given a chance to test the sensation: Prince was getting it!

"Daisy is going over to take Josephine Blake for a ride," explained Daisy's mother. Daisy had had very little to say to me all the morning. I can't say that her neglect of me had been exactly studied, but it had been brisk and businesslike. She seemed too much occupied with other and more important matters to pay much attention to me.

"I'm going to take Dolly and drive into town this morning," continued Daisy's mother, "and if you would care to go, I should like to have you."

I said I should be charmed. And I pretty nearly meant it: for, next to Daisy, Daisy's mother is one of the most delightful of companions. Besides, if Daisy was going to be away, there was no special reason for my staying at the house.

After bestowing upon Prince sundry loving caresses, Daisy came up the walk, remarking, as she passed into the house, "I've got to put on a cooler dress; it's grown dreadfully warm."

The stable-boy brought Dolly round to the gate and then took himself off down the road on some errand or other.

"I'll be ready in a minute," said Daisy's mother, rising and going into the house. She had been gone only a moment when Katie Porter came running toward me, breathless and excited. The Porters are Daisy's nearest neighbors.

"Oh, Mr. Dawson!" she cried, "Archie has swallowed a Jew's-harp and is choking. Can you go for a doctor quick?"

"Swallowed a Jew's-harp," I repeated stupidly.

"Yes. Hurry, please, or he'll be dead!" Saying which Katie started back home on a run.

I glanced at Dolly and then at Prince. Both stood there harnessed, ready for the race. It was a good two miles to the nearest doctor and Prince would cover those two miles a third quicker than the mare.

"The idea of a boy swallowing a Jew's-harp, anyway!" I muttered. "I suppose he'll swallow a music-box next."

"Well, Mr. Prince," I said, unhitching him, "if you cut up any of your deviltry, you'll have that boy's life on your conscience. I've told you about it and now it's up to you!"

The Hero Wins Out

With a final regretful glance at Dolly, peacefully standing unhitched behind us, I sprang into the buggy and the beast thereto attached started off so suddenly as to nearly throw me out before I could get seated. "All right!" I muttered, "if you can't act like a Christian, don't!"

He was veering wildly toward the gutter, but grasping the reins firmly I steadied his course a little and down the road we tore. I didn't know whether he was running away or not, and I don't think he knew himself. I supposed, of course, he was and probably he supposed so, too. Nevertheless, I had a firm grip on the reins—and I wasn't scared, in fact, after the first dozen rods, I felt a kind of exultant delight in the situation. "If he doesn't break our necks, we'll have the doctor in a jiffy," I thought, and I cautiously drew the whip from the socket. I remembered Daisy had told me only yesterday that Prince had never felt a whip. "This is an excellent time for him to have a taste of that harmless and rather common experience," I said to myself, touching him lightly with the lash. What exhibition of wrath and malevolence he might have displayed under other and less bewildering circumstances I cannot say, but now the brute was too astonished, I suppose, at my daring to drive him at all to have any surplus emotions for grappling with the fact that I was driving him like mad and whipping him to boot! The only effect it had on him was to make him raise his speed to an even 2:10 gait.

The few persons that we passed stared, apparently in the same doubt that Prince and I were in. One man, less doubtful or more courageous than the others, made as if he intended to stop us, but we swept by him unheeding. I said nothing to Prince nor he to me. We were both attending strictly to business.

"If I can stop him when we get to the doctor's, Archie and I have a fighting chance," I mused, "but can I—can anything short of a smashup?"

Nevertheless, a dozen yards from the doctor's gate I said—not loud, but very decidedly—"Whoa, Prince!" and we drew up as neatly as I have ever seen it done.

"Stand still!" I commanded in the same calm and decided way, and without stopping to hitch him hurried to the doctor's door.

A Record-Breaking Drive

In thirty seconds the doctor was in the buggy with me, and whirling around in the street in the precise daring fashion I have so often envied, we went tearing back toward home, Archie and the hushed Jew's-harp.

The doctor was used to horses and no coward, but said he; "Don't you think you are driving a bit recklessly?"

"This is no time," I answered, "for saving the horse: a life hangs in the balance."

He made no further comment, but I could detect distinct relief on his face as he leaped from the buggy in front of Archie's home.

A strain or two of unmusical music, low and husky, reached my ears, and glancing up at an open window on the second floor I saw Archie softly playing on a harmonica. Katie came to the door. "Oh, it's you!" she said. "We got it out. Mama stood him on his head and he coughed it out. I guess he's all right now."

A few minutes later we were sitting on the piazza drinking lemonade. Daisy was out by Prince, absently rubbing his nose, but she was looking at me. Her eyes were bright and friendly.

"No, sir," said the doctor reminiscently as he sucked at his straw, "I don't think I ever rode quite as fast behind a horse before. You handled him very well, too, Mr. Dawson."

Later in the day Daisy came and stood quite close and looked up into my eyes. "You'll forgive me, Max," she said. "I'm glad it wasn't true."

"But it was," I said.

"Well, it isn't now if it was then," she answered, "and it never will be again."

"I'm not so sure of that," I said. "I don't like the beasts and never did."

"But speaking of forgiveness," I added, "I'll forgive you on one condition." She looked into my eyes, and suddenly all triviality of speech and thought was flown.

A half-hour later we passed within sight of Prince's paddock. He was gazing out at us, his head sunk dejectedly. "Poor Prince!" Daisy murmured, and then, in full sight of my envious and disappointed rival, she deliberately lifted her lips to mine.

Fashions for Big and Little Folks

Designs by Miss Gould

AN EXCEPTIONALLY attractive design, suited specially to the new cotton Bedford cords, the new dimities and zephyrs is illustrated on this page in patterns Nos. 1510, and 1511. Here we have just the daintiest sort of a waist made with a chemisette and a deep sailor collar. The sleeves are in an approved style. They are three quarter length with a group of tucks at the top and finished with a flaring cuff which should be of a contrasting material from the sleeve proper and should match the sailor collar. The skirt is one of the new flounce models, having a panel front with the upper part circular and finished with a gathered flounce. Both the waist and the skirt fasten at the left side of the front.

Few well-dressed women these days are satisfied with just a smart-looking gown, but they insist on having every accessory pertaining to their costume harmonious both in color and in style, and stockings are one of the most important of these accessories. To-day women can buy exquisitely fine lisle thread stockings scattered with pretty flower designs at the most reasonable prices. These hose are almost as attractive as silk.



No. 1339—Dressing-Sacque Tucked Back and Front

Cut for 32, 36 and 40 inch bust measures. Material required for medium size, four and three fourths yards of twenty-two-inch material, with three yards of embroidery for trimming

No. 1161—Child's Rompers

Pattern cut for 2, 4 and 6 year sizes. Quantity of material required for medium size, or 4 years, three and three fourths yards of twenty-seven-inch material, or two and three fourths yards of thirty-six-inch material

No. 1473—Girl's Apron—High or Low Neck
Pattern cut for 4, 6 and 8 year sizes. Quantity of material required for medium size, or 6 years, three and one half yards of twenty-four-inch material, or two and three eighths yards of thirty-six-inch material

No. 1342—Apron With Pointed Bib Collar
Pattern cut for 4, 6 and 8 year sizes. Quantity of material required for medium size, or 6 years, three and three fourths yards of twenty-four-inch material, or two and five eighths yards of thirty-six-inch material



No. 1510—Waist With Sailor Collar

Pattern cut for 32, 34, 36, 38 and 40 inch bust measures. Material required for medium size, two and seven eighths yards of twenty-seven-inch material, or two and one eighth yards of thirty-six-inch material, with seven eighths of a yard of contrasting material for collar and cuffs and five eighths of a yard for chemisette

No. 1511—Panel Skirt With Flounce

Pattern cut for 22, 24, 26, 28 and 30 inch waist measures. Material required for medium size, 26 inch waist, eight yards of twenty-seven-inch material

Madison Square. Patterns

THESE are the patterns that are right in fit, right in style and right in price. For every design pictured on this page we will furnish a pattern for ten cents. If there are any little folks in your family, you will find many designs on this page that are just the sort you have been looking for. Rompers, aprons and simple dresses for children are specially featured in the patterns illustrated in this issue.

We have a liberal offer to make you in regard to these patterns. Here it is: We will give one Madison Square pattern if you send us only one new subscription to FARM AND FIRESIDE for eight months at the special price of twenty-five cents. The subscription must be for some one not now a subscriber to FARM AND FIRESIDE. This offer holds good up to June 10th. Send orders to the Pattern Department, FARM AND FIRESIDE, 11 East 24th Street, New York City.

Follow these directions when ordering patterns: For ladies' waists, give bust measure in inches; for skirt, give waist measure in inches; for misses' and children, give age. Don't fail to mention the number of the pattern you desire. Satisfaction guaranteed.

A distinctive feature of the Madison Square patterns is the originality of their designs—up to the moment in style, but never extreme.

If you have not seen the new pattern catalogue of Madison Square patterns, you will find it to your interest to send for it. The price of this catalogue is ten cents. Order the catalogue from the Pattern Department.

HERE are a few clever renovating ideas worth knowing. Princesse gowns may be changed materially in appearance by the simple addition of a crush girde of soft silk or satin. The girde may reach only around the sides of the waist from under the front panel to disappear under the sides of the back panel, the girde to have a slight dip in the front. Or, the girde may be made to meet at the back with a buckle finish.

Princesse gowns may be further changed by cutting them down to within three or four inches of the waistline, thus making an attractive skirt to wear with separate blouses.

Old coat suits of the elbow-sleeve variety may be converted into charming one-piece dresses. The coat with the addition of a chiffon or net yoke and undersleeves, will make the waist and probably provide straps for the skirt, which may be applied as tailored touches.

Perhaps you do not feel that you can afford a new suit this season and so you will be glad to know that to turn one's suit is really not the difficult task it sounds. Where the fabric is the same or almost the same on the wrong side, the effort is usually worth while.

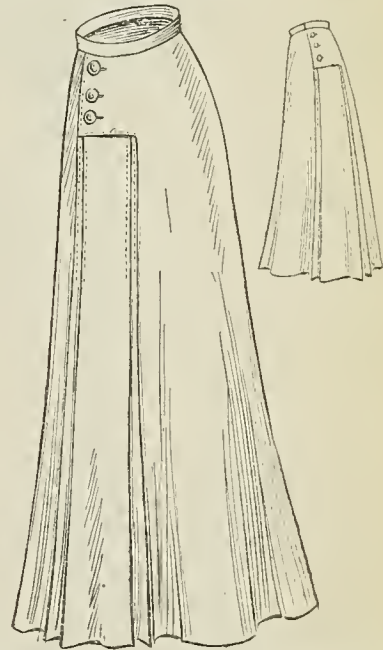

No. 1485—Skirt With Box-Plaits Back and Front

Cut for 24, 26, 28 and 30 inch waist measures. Material required for medium size, or 26 inch waist, five and one half yards of thirty-six-inch material

No. 1330—Child's Guimpe Dress

Pattern cut for 6, 8, 10 and 12 year sizes. Material required for medium size, four and three fourths yards of twenty-two-inch material, with one and one half yards of thirty-six-inch material for the guimpe

No. 1470—Child's Yoke Dress

Pattern cut in 1, 2, 4 and 6 year sizes. Quantity of material required for medium size, or 2 years, two and five eighths of twenty-four-inch material

Madison Square patterns are for all members of the family—mothers, grown-up daughters and even the very little girls—and there is nothing like these patterns for the busy mother or the daughter learning to do her own dress-making, for they are the simplest patterns to use and they always insure a perfect fit. Each Madison Square pattern costs ten cents.



No. 1161

No. 1473

No. 1342

No. 1330

No. 1470

Copyright, 1910, by The Crowell Publishing Company



THE HOUSEWIFE'S CLUB



EDITOR'S NOTE—Most every woman has originated some sort of a device or convenience to make part of her housework easier and less burdensome, and to all who have, we would ask that you write and tell us about it. Aside from making a little pin-money for yourself, you will be helping others, and this is what "The Housewife's Club" is for. We will give \$2.00 for the best description and rough sketch of an original home-made household convenience or labor-saving device, and \$1.00 for the next best, or any that can be used. We will also give 25 cents each for good kitchen hints and suggestions, also good tested recipes that can be used. All copy must be in ink. Contributions must be written in ink, on one side of the paper, and must contain not more than 250 words. We would suggest that contributors retain copies of their manuscripts as no contribution will be returned. Address "The Housewife's Club," care of Farm and Fireside, Springfield, Ohio.

by the tenth of June. Contributors must be written in ink, on one side of the paper, and must contain not more than 250 words. We would suggest that contributors retain copies of their manuscripts as no contribution will be returned. Address "The Housewife's Club," care of Farm and Fireside, Springfield, Ohio.

To Conquer Stubborn Corks

WHEN a bottle has an exceptionally short cork it is often a hard and trying matter to draw the cork out. As soon as the cork is first drawn with the cork-screw, push a new wire hair-pin through cork from the bottom and twist the two points to form a handle, as shown in the illustration. The next time you want to take out the cork you will have something to get a grip on and the cork may easily be drawn without the slightest difficulty, thus saving time and vexation.

A hair-pin device for pulling out corks. MRS. S. J. H., Wisconsin.

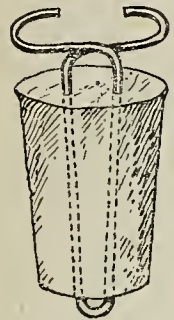

For Shiny Goods

TO REMOVE the shiny look from black coat collars, sleeves, etc., where the nap of the cloth is not entirely worn off, ammonia water is excellent. If the whole coat needs a thorough cleansing, use strong black coffee, to which a few drops of ammonia have been added, and sponge the garment with a piece of black woolen cloth. B. E. S., Minnesota.

To Stretch Lace Curtains

A GOOD way to dry lace curtains without a stretcher is to tack some sheets or old quilts down on the floor, then pin each scallop of the curtains to the sheets. Several curtains may be dried at once if all are of the same size. MRS. J. L. R., Ohio.

A New Use for Sealing-Wax

FANCY hat and lace pins are much worn this season and they are seen in many bright colors. Sometimes only one color is used and often two or three are combined in one pin. It is not always easy to secure attractive pins of this order and so I want to tell you how you can make them at home and with little cost. The materials needed are a lamp with a chimney, a box of sealing-wax in several colors and some pins. If you want to make hatpins, use the ordinary hatpin with a ball top, and if you want to make lace-pins you will need the regular common pins or plain black-headed ones. The latter are better, as the pins have sharper points. Melt the wax over the chimney of the lamp, being careful that it does not get into the

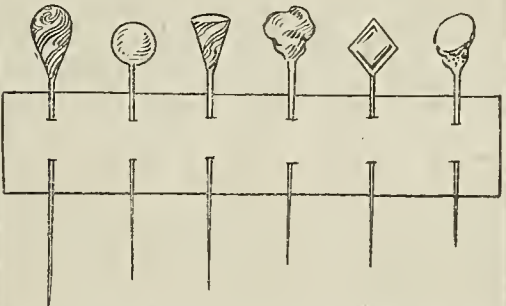

Ordinary steel pins transformed into fancy pins by making the heads of sealing-wax in any attractive colors and novel shapes

flames; put the wax over the head of the pin and keep on adding it until you have enough to make the sized pin-head desired. While the wax is soft twirl it between the thumb and fore finger. By doing this a smooth oval pin-head is formed, and when this is done it should be dipped in cold water, so that the wax will harden. To make variegated ones, wax in two or three different colors may be used on the same pin. The colors should be applied when warm and then by twirling between the thumb and forefinger the result will be a very attractive color combination. A dozen of these pins on a little piece of feather-stitched silk make a very pretty attractive gift. MRS. F. J. M., Massachusetts.

A True Housewife's Ladder

THIS handy ladder has proved a great help to me when cleaning windows or picking fruit, and I wish to tell our readers about it. The ladder is twenty-seven and a half inches long and is nailed five inches from the top to a soap-box twenty-six inches long, sixteen inches wide and five and a half inches deep. There is a brace near the foot of the ladder which is fastened to the box. Even though the device may be a little awkward to handle, the housewife has the happy consciousness of knowing that there is absolutely no danger of the ladder doubling up and falling over while she is on it. MRS. C. E., New York.

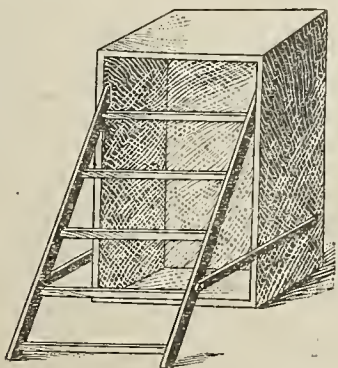

Step ladder fastened to a soap-box

Sandals From Old Rubbers

A GOOD way to prolong the life of over-shoes when the heels have worn out is to cut the heels out of the rubbers and bind the cut edges with black silk tape, stitching it firmly in place. In this way I make my overshoes into sandals which not only look quite well, but give very



good service. The sketch given above will give a good idea of how the old rubbers are transformed into sandals. M., Virginia.

Our Sons and Daughters

I HAVE learned that it is wise to begin the forming of character in the child's extreme youth. Take the habit of neatness. Most little ones will leave toys of all kinds on the floor just as they were used. A mother will be surprised to see how soon the child will learn to pick up all these things and put in a box when through with them if the box is provided and the child is taught that he is "helping mama." Many habits can be formed this way.

The tiny girl learns to dust the chairs, to wipe the spoons, and other useful things. At night she folds her clothes, putting them on her own little chair while brother does the same with his. Neatness and industry are inculcated early and last through life. Every trait thus formed in childhood goes to the making of character and grows more interesting as the loom of time works its marvelous changes to the full dawn of adult life. To the mother it is given to closely watch this loom that the threads go not astray and at last she will look upon the characters of her loved ones with satisfaction.

We Must Remember

that in our work as mothers we must use no iron-bound rules. Too often this mistake is made. We should study the disposition of each child. What would be a punishment for John might not be suitable for James. A plan of study for Mary might be altogether wrong for Anna. We should try to bring the good points to the front. Whatever the growing boy or girl develops a love for, give them full scope. Their life work will come later along this line. Watch it. Inculcate the idea that whatever your children become, he or she will have their heart in the work and strive to bring it to the highest level obtainable. Success comes to those who, knowing one thing, knows that *one* well, but is ever alert to possibilities of betterment along that specialty. S. D. G., Texas.

To Can Tomatoes

LAST year I canned twenty-two quarts of tomatoes with great success and I thought our readers would like to know my method of doing them. I always had trouble in keeping them until I tried this plan. My canner is a zinc pail large enough to hold three glass quart jars placed in an upright position. Have a lid to fit the pail; invert a pie-plate or place a cloth in the bottom of the pail and the home-made canner is ready for use. Pare sound tomatoes, fill the jars, put on the rubbers and screw on the lids. Place jars in the canner, which should be filled with water until it rises almost to the top of the jars. Bring the water to boiling-point and allow jars to remain in the water until the contents boil. Then take them out, tighten the lids again, stand them aside to cool and they are ready to put away until used. MRS. J. M. L., Florida.

Keeping an Egg Record

WE HAD tried various schemes to keep account of the eggs gathered each day, but all failed until we tried the following plan: A large calendar was procured and tacked to the inside of the cupboard door. A pencil hung from the same tack and every evening the number of eggs gathered was marked opposite the date. The number of eggs marketed each month was placed on the margin of the calendar, thus at the close of the year we knew exactly how many eggs we had used and how many were sold. L. H., Iowa.

Substitute for Molasses

AFTER promising the children some gingerbread, I found there was no molasses, so rather than disappoint them I poured the syrup from preserved pears into a dish, added a tablespoonful of vinegar to each cupful of syrup and proceeded to make the gingerbread in the usual way. The result was so satisfactory that occasionally I use pear-syrup instead of molasses, as we like it sometimes for a change. Other fruit syrups may also be used. MRS. M. C. S., Missouri.

Mucilage at Little Cost

BUY five cents' worth of gum arabic. Dissolve it in warm water and you will have a better and cheaper mucilage than you can buy at the store. M. H., Montana.

A Sewing-Machine Secret

TAKE out the screw that holds the foot plate, remove it and you will be surprised at the amount of lint that has accumulated there. With a penknife clean under the whole of the plate and the little grooves. Of course, the needle in the machine must be taken out before the work is begun. Sometimes this accumulation of lint is the main cause of the machine running hard or not carrying the work and it is a secret that is well worth knowing. I have just cleaned mine this way and it runs like a new machine. B. E. S., Minnesota.

Three Useful Hints

ALITTLE powdered borax added to starch will make the clothes glossy. To set delicate colors in embroidered handkerchiefs, soak them ten minutes previous to washing in a pail of tepid water in which a dessert-spoonful of turpentine has been well stirred.

Imitation bronze articles may be re-colored by mixing together one part of muriatic acid and two parts of water. Be sure to see that the bronze article is perfectly free from grease and dirt, and apply the diluted acid with a cloth. When it dries, polish with sweet oil. O. M. H., Virginia.

A Clever Suggestion

DOES the woman live who never had her machine-oil bottle spill oil all over machine and drawer contents? To do away with this, get an empty mucilage or ink bottle of squat proportions, fill with oil and cork tightly. Get a paste board box or lid just the size of the interior of machine drawer at the back end and cut a hole in the box to admit neck of this bottle. Now place at the back of the most unused drawer in your machine and it is ready when needed and there will be no danger of it upsetting. A. R. M., Illinois.

Hints on Butter-Making

I AM sure that the women who make butter will be glad to know that the butter is not spoiled or even hurt if the cream happens to get too hot or scalded. Simply take off the butter, pour cold water over it and set it in a cool place until it hardens. Then with a paddle you can work all the milk out, and the butter will become firm and hard and sweet. It is the milk scalded into the butter that causes it to look white and puffy and to taste sour. This is my own idea and used with success for years. MRS. F. P., Tennessee.

The Genuine BAKER'S Breakfast Cocoa



with the *delicious natural flavor* and the rich red-brown color characteristic of this high grade cocoa is made only by

Registered U. S. Pat. Office
Walter Baker & Co. Ltd.
Established 1780 DORCHESTER, MASS.



Reg. U. S. Pat. Off.

Half the money spent for chimneys would be saved if everybody bought Macbeth "Pearl Glass" lamp-chimneys.

Because Macbeth lamp-chimneys *never break from heat—they will melt first.*

Then they're handsome—clear—crystalline—and give a lamp a well-bred look.

Unless my name is on a lamp-chimney it is *not* a Macbeth.

I have a book which tells which chimney to get for any burner made. It is free. Address

MACBETH, Pittsburgh.

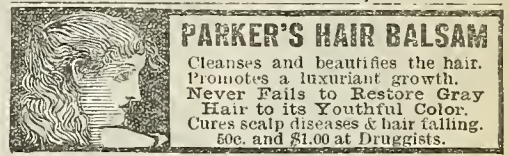

PARKER'S HAIR BALSAM

Cleanses and beautifies the hair. Promotes a luxuriant growth. Never Fails to Restore Gray Hair to its Youthful Color. Cures scalp diseases & hair falling. 50c. and \$1.00 at Druggists.

IT SLUGS HARD

Coffee a Sure and Powerful Bruiser—

"Let your coffee slave be denied his cup at its appointed time! Headache—sick stomach—fatigue like unto death. I know it all in myself, and have seen it in others. Strange that thinking, reasoning beings will persist in its use," says a Topeka, Kansas, man.

He says further that he did not begin drinking coffee until after he was twenty years old, and that slowly it began to poison him, and affect his hearing through his nervous system.

"Finally, I quit coffee and the condition slowly disappeared, but one cold morning the smell of my wife's coffee was too much for me and I took a cup. Soon I was drinking my regular allowance, tearing down brain and nerves by the daily dose of the nefarious concoction.

"Later, I found my breath coming hard and frequent fits of nausea, and then I was taken down with bilious fever. "Common sense came to me and I quit coffee for good and went back to Postum. I at once began to gain and have had no returns of my bilious symptoms, headache, dizziness, or vertigo.

"I now have health, bright thoughts, and added weight, where before there was invalidism, the blues, and a skeleton-like condition of the body.

"My brother quit coffee because of its effect on his health and now uses Postum. He could not stand the nervous strain while using coffee, but keeps well on Postum.

"Miss F., I know personally, was incapable of doing a day's work while she was using coffee. She quit it and took up Postum and is now well and has perfectly steady nerves."

Read the little book, "The Road to Wellville," in pkgs. "There's a Reason."

Ever read the above letter? A new one appears from time to time. They are genuine, true, and full of human interest.

From Oven Door to Farm House Door

That sums up the whole story
when you buy soda crackers by
name—

Uneda Biscuit

As soon as they are baked they are
placed in moisture-proof packages. In
this way they are kept free from dust,
damp and other harmful conditions.

This means that you are *always*
assured of fresh, clean, crisp, unbroken
soda crackers no matter *where* you
buy them or *when* you eat them.

They come in five cent packages.

(Never sold in bulk)

NATIONAL BISCUIT COMPANY

RUBS Clothes Clean

Always
remember
the name



DOES not pound, tumble or churn them. But *rubs* them between
these two rub-boards just as when washed by hand. The
only way to get them *clean*.

The board at the right fits into the bottom of the
machine. 15 shirts or their equivalent are placed
in it. The lid is lowered and the other board
presses the clothes.

A child turns the operating wheel or can be
run with a gasoline engine or any other light
power. The two boards oscillate back and
forth in opposite directions, *rubbing and squeezing,*
rubbing and squeezing, *rubbing and squeezing,*
and *squeezing.*

The loosened dirt drains through the lower board
into a special chamber away from water and clothes—
an *exclusive* feature. In a few minutes every piece is
spotlessly clean. Anything, from lace curtains to
blankets, is washed *without wear or tear.* Success-
fully sold for 20 years. Over a million in use.

Write for booklet giving wash-day hints,
showing wash-day in all countries, and telling
how you can try the Boss in your home
at our risk.

The Boss Washing Machine Co.

Dept. 21, Norwood Station, Cincinnati, O.

Beware of painted machines. Paint hides de-
fects. The Boss shows the natural grain of the
Louisiana Red Cypress, that steam-tight wood
from the Louisiana swamps. No splitting.

Here Is Something New From Kalamazoo

Prove for yourself in your own home, that the Kalamazoo is the most
perfect—most economical—most satisfactory range for you to use—Your
money back if it's not.

Send for Catalog No. 183 with special terms and compare Kalamazoo prices with others

Cash Or Time Payments

We want every housewife to know the comfort and convenience of a Kala-
mazoo in her home. You can buy on *easy time payments* or pay cash if
you like. Either way—you save \$10 to \$20 on any stove in the catalog. We
make it easy for responsible people to own the best stove or range in the world.

We Pay the
Freight

Kalamazoo Stove Co.
Kalamazoo, Mich.

A Kalamazoo
Direct to You

You'd Rather Wash With an O. K. Than Have A Woman Around

Why wear yourself out by a whole day over a wash tub
or why go to the bother and expense of a washwoman around
the house all day? With *one hour's* easy, pleasant work you can
dispose of the biggest washing with an

O. K. Roller Gearing Rotary Washer

Makes clothes white as driven snow without injury. Runs so easy a
child can turn it. Nothing to get out of order. Never wobbles or warps.
Steam-proof cover keeps water hot longest. Handsome and durable.
Our Guarantee Inside. Send postal today for Free Washer Book.

H. F. BRAMMER MFG. CO.

1452 Rockingham Road, Davenport, Iowa



Round About the Farm Home

By Edgar L. Vincent

THE average farm home might be made quite a bit brighter and better than it is. Don't you think so? Ride across the country most any day and how many such homes will you see that you would really like to live in? Isn't it true that you will see a great many more than that would make ideal farm homes? Let's not draw any contrasts, they might hit some of us pretty hard; but let's just be fair and say that a good deal yet remains to be done before the average farm is just as nice and homy as it should be.

Now, it is all right to point out weak spots in anything. Somehow our eyes seem to have been trained so that they look first of all for the things that are not just as they should be. It is so easy to criticize! The poor spot in the piece of goods, the flaw in the metal—we can all find these, but how to make them better is another matter.

How would it do for us to sit down a little while and think out this matter of the farm home all by ourselves?

But, in the first place, let us say that if anybody is handicapped for money to do the things that need doing, there is no reason why we may not do something, and every little helps. We have our hands and know how to use tools fairly well. We have a reasonable amount of good common sense and can apply it with some degree of success if we set out to do it. So why stop and say, "I can't do anything!" Let's do the very best we can and that will help on to something better.

There is a passion, too, with a great many men to put into the bank every cent they can rake and scrape over and above the cost of living. That isn't always the best form of investment. Better put a little into making the old home nicer than to lay it up in the bank to be a bone of contention after you are gone.

Well, so far, so good. Now what can we do? How would it do to paint the old house over? It will cost something for paint, but we can get a brush and put it on ourselves. I painted some on our farm buildings myself. At first there were some streaks I didn't like; but, mind you, I began around on the back side, where folks wouldn't see what kind of a job I was doing, and before I got through with it I wasn't ashamed to have anybody know that I was my own painter. Anybody can do as well as I did.

And, then, most farm-houses need a slicking up around them. Let's see what we can do about this the coming season. Right up the fences, trim out the bushes and things that have no business there and, above all, mow the yard and keep it cleaned up all summer long.

It would be a good plan to let in more sunshine than gets into most of our farm

homes. It is enough to give a man the blues to go into some farm-houses. How dark and dismal they are? It is a shame. No wonder we have to take medicine and have the doctor a good share of the time. Let the air and sunshine into the house. Then the doctors can take a vacation.

The down-cellar of many farm-houses is a sight to behold. Don't you think so? If I could, I would have a big bee and raise every farm-house in this whole country up, out of the ground not less than two feet, lay a good wall under the sills, dig the cellar all out clean, and then sit down and enjoy myself. The cellar ought to be just as neat and clean as the parlor. Air and light ought to sweep through it, and there should be a cement or flagging floor on the bottom.

But let's not stop till we have put some porches and bay windows in the old farm-house. These add so much to the appearance and comfort of the place. Take an old house and build a neat porch along the side, open up the sunny end and extend a bay window out a few feet, put some plants in the recess and it will make such a difference in the looks of things that people who pass will say, "Wonder if a new man has moved in?"

Keep the good work up until you have set out some climbing vines here and there, planted some roses and other homely flowers wherever there is a corner for them. Your farm will take on a look of comfort that will set everybody around the neighborhood doing the same. Measles is not the only thing that is catching. Start the good work, and before you know it somebody else will be up to the same caper. Isn't it worth while to set a good movement going? Sometimes the world makes a great stew about the man that starts a new lodge or company of some sort; but, honestly, I believe it is a hundred times better to do something to make the country home better and happier and more comfortable than to organize a company or start a bank.

There isn't a bit of doubt in my mind that the surroundings of the farm home have more to do with the health and happiness of the men and women who live in them than any of us knows. Just to step into a farm-house where everything is neat, bright and full of harmony is enough to make the heart better for days to come. To ride along the road and catch a glimpse of a place where all is in place, the buildings in good condition, the grounds cared for and somebody singing as she goes about the house, why, the world grows brighter, the heart leaps up and out in a new song and every shadow flies out of the sky.

And who of us would not like to have a hand in helping the world that way?

We may all do it! What! You and I? Yes, just you and I!

Page County Ideal for Its Rural Schools

[CONTINUED FROM PAGE 18]

Seems as though when I get to playing ball and the boys do something I don't like, I just forget." Such a boy was Walter, rough, uncouth, without ideals or without strength to live out the ideals that he had, manly in a way and frank and good-hearted. He was the hope and despair of those who wished to help him.

And this is the wonder of that tulip-bed. The boy who appreciated the tulips most was Walter. Down on his knees by the bed he dropped, his torn straw hat by his side and touching almost reverently a great crimson blossom he said, "See, this is mine. Is it not the prettiest of them all?" I was not surprised when his teacher said to me very quietly, "Walter does not swear or use tobacco any more." The boy who learns to love one beautiful thing has no longer any room in his heart or soul for impurity or vice. The picture of that boy, in his blue overalls, with his straw hat at his side, the morning sun touching with gold his tousled hair, as he bent lovingly over those bright flowers and touched them so gently with his brown hands, will be with me always.

I will close with an account of what was done for this school house and grounds during the past two years as told by the teacher, Mrs. Anna Hobson.

"When I took this school in the fall of 1907 I found very little to inspire one to make much effort in trying to beautify the surroundings. I soon learned why so little had been done to improve it. There was only one half acre of playground and a dilapidated wire fence on three sides, with the front unfenced. There was no means of protecting things. They said the playground was too small to plant trees.

"The county superintendent, myself and two of the directors set the ball rolling and before the next year had passed the school board had purchased one half acre more, put up a splendid woven-wire fence, remodeled the closets, moved the coal-house which had always stood partly in the road, dug a well, put in a new iron

pump, painted the school-house and planted twenty-two elm trees.

"When I came, there was practically nothing on the grounds but the school-house, coal-house and outbuildings. Where I found cinder-piles, there are now blooming beds of flowers. Many of the mole-hills are converted into flower-beds, too. The yard has been raked and trash carried away. The parents generously gave what they had. One parent even came and put things out for us and tended to them in the summer when needed. Another parent sent some rose-bushes.

"This year when school was out I divided the care of the plants with the children. One girl has charge of the two geranium-beds, two boys weed and cut the sweet peas and nasturtiums, another cares for six evergreens we planted this year, another hoes the sunflowers, another looks after the woodbines we planted to run over the coal-house and over the screens that we put in front of the closets, and others are to look after any other plants that needed attention when they visited the school-grounds.

"We closed our school with a picnic. The parents came and guides were appointed to show them what we had done. It was hard to say which enjoyed this most, the parents or the pupils.

"They used to have rings in the school-house, and teacher and pupils would tie their horses there to protect them from the wind. Near one of these favorite hitching-posts we have a fern-bed now.

"Inside we kept the house clean. It has been scrubbed five times this year. Through the efforts of the school a sectional book-case, a dictionary and shelf, shades and draperies have been added. The room was always clean, and the stove black.

"The best part of the work has been that the interest has increased each year. I can truthfully say that my people and children are thoroughly interested and I feel that our work will be cared for and in years to come, the results will show."

Do you want this Pony?

For
Our
Boys
And
Girls



This is "Fuzzy," and his cart and harness. He will be given away by Farm and Fireside to some lucky boy or girl July 30th

Read How to Win "Fuzzy"

"Fuzzy" is the name of this beautiful pony and you can win him and his cart and harness without spending a single cent.

How would you like to have your father or mother tell you that you could have one of the prettiest Shetland ponies in America all for your very own? Wouldn't you be happy? Well, FARM AND FIRESIDE is going to give away "Fuzzy" on July 30th to some boy or girl who will do us a favor. Wouldn't you just love to hitch up "Fuzzy" and take your friends for a drive in his pretty cart? You would be the envy of all your friends, for "Fuzzy" is the prettiest Shetland pony the Pony Man could find for his boys and girls, and he has looked the country over for pretty ponies.

But "Fuzzy" is not the only pony that FARM AND FIRESIDE will give away on July 30th. Altogether we shall give to our boys and girls

**Three Beautiful Shetland Ponies
100 Magnificent Grand Prizes and
Thousands of Dollars in Prizes and Rewards**

Just think of it, three Beautiful Ponies for our boys and girls, and three magnificent pianos! Never before has FARM AND FIRESIDE offered such fine ponies, and so valuable rewards. Never before have our boys and girls had such a chance to win a Beautiful Pony. Dozens of lucky boys and girls have won ponies from FARM AND FIRESIDE, and they have been the happiest boys and girls in America, I can tell you. In addition to the Ponies and Pianos, the Pony Man will give away on July 30th hundreds of Magnificent Prizes, including bicycles, gold watches, sewing machines, shot guns, talking machines and almost everything else you can think of that is beautiful and useful. Don't you want some of these prizes? You can win a fine prize *sure* if you try. These are not ordinary prizes at all nor is this an ordinary prize contest, for in this contest there will be

A Prize for Every Enrolled Contestant

That is FARM AND FIRESIDE's guarantee to its boys and girls, and this guarantee is backed up by a reputation of over 33 years and by hundreds of thousands of dollars capital. We mean every word of it. Just as soon as you become an enrolled contestant you will be entitled to a Prize. All you have to do to win "Fuzzy," or one of the other Ponies or Grand Prizes, is to get enough friends to subscribe to FARM AND FIRESIDE. That is very easy, because FARM AND FIRESIDE is the best farm journal published, and everybody likes it. In addition to your prizes we will pay you liberally in *cash* for every subscription you get. FARM AND FIRESIDE also guarantees that every contestant will be rewarded according to the number of subscriptions he or she gets. Could any offer be more liberal? Just as soon as you get started you will be a Prize-Winner *sure*, and nothing in the world can keep you from winning "Fuzzy" or one of the other Grand Prizes if you hustle enough. Just think, there are three Beautiful Ponies, all sound as a dollar and gentle as kittens—all to be given away on July 30th. Don't you want one?

How to Get "Fuzzy"

Write your name and address on the coupon below (or a postal-card will do), cut it out and send it to The Pony Man, FARM AND FIRESIDE, Springfield, Ohio. That is my address and just as soon as I hear from you, I will send you a lot of pictures of the other Ponies and Prizes and a lot more valuable information that will help you to win "Fuzzy" and I will send you a lot of other things besides. Write at once and I will send all this valuable material to you Free. Be sure and write to me to-day if you want to win "Fuzzy."

The Pony Man.

Farm and Fireside, Springfield, Ohio.

P. S.—If you want to make sure of a Prize the very first thing, don't wait to hear from me but get ten of your friends to take FARM AND FIRESIDE or to renew their subscriptions at 25 cents each for an 8-months subscription. Then you will be an Enrolled Contestant and a Prize-Winner *sure*, with a running start for "Fuzzy." Keep five cents out of each 25 cents you get as your cash commission. Don't wait! Start to-day!

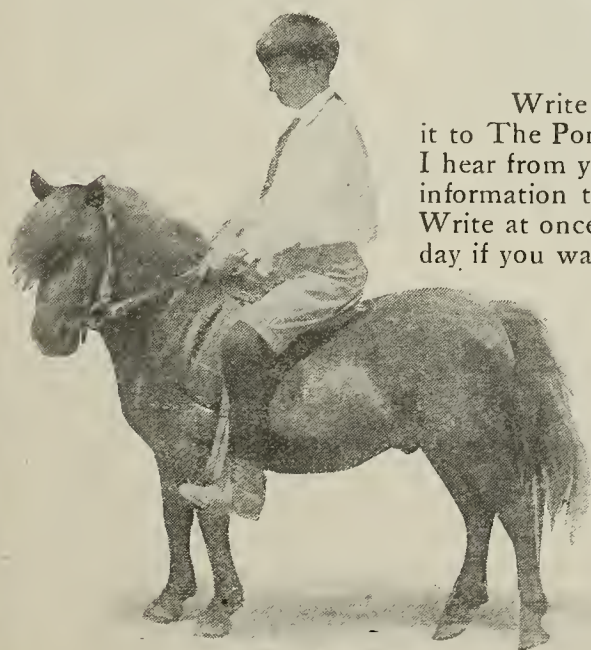

Don't you love "Fuzzy?"

CUT OUT THIS COUPON AND MAIL TO-DAY—DON'T WAIT.

DEAR PONY MAN:—
Please send me at once all the pictures of the ponies and all the other things you promise, and tell me just how to win "Fuzzy." I am very anxious to win "Fuzzy," so save me a place in the contest. I will send my ten subscriptions as soon as possible.

Name.....
R. R. or Street.....
Town.....
State.....
5-10

The Housewife's Letter-Box

We shall be glad to have our readers answer any of the questions asked, also to hear from any one desiring information on household matters. We want this department to prove helpful to our readers, and from the letters we have received we feel sure that our aims have been realized. While there is no payment made for contributions to these columns, still our readers may feel that their help and assistance is doing a great deal for others. All inquiries and answers should be addressed to "The Housewife's Letter-Box," care of Farm and Fireside, Springfield, Ohio.

Questions Asked

Will some one please tell me—

A formula to make snow-white soap from oil, spermaceti and wax or oil, spermaceti and bayberry-wax; also one for making orange-flower water from the essence of neroli? How much essence and water should be used?
B. W. M., New Jersey.

How to remove wagon-grease from a light tan coat without harming the cloth?
A SUBSCRIBER, Wisconsin.

How to cook Brussels sprouts?
Mrs. M. E. C., Ohio.

How to rid the house of fleas?
Mrs. M. M. B., Missouri.

How to make artificial honey?
L. A. N., Oregon.

How to make hulled corn with wood-ashes or other means?
A NEW HAMPSHIRE READER.

How to make pork cakes with eggs?
Mrs. J. W. D., Minnesota.

Mrs. E. J. C., of Ontario, would be grateful if readers would answer the following questions:

How to make the pulps from apples, pears, plums and berries?

Will some one kindly send me different uses of hops in "ferment" and "beverages?"

I would appreciate it if some one would send me different ways of potting meats and soups, to be kept an indefinite length of time.

I would like a good way to preserve cider sweet for home use, also different ways for making sweet wines from fruit. I live on a fruit farm and answers will be appreciated.

Mrs. S. B., Ohio, would appreciate some patterns for making tatting collars.

Mrs. J. F. E. O., of Illinois, would like pattern for a crocheted windmill design.

Questions Answered

Two Curtain Ideas

For Mrs. M. L. L., Oklahoma

I have made some very attractive curtains for my home out of lawn. I like them every bit as well as scrim. Take white lawn and make the curtains as long as you wish them. Mine are a few inches below the window-sill. Run a rather wide hem down the side and along the bottom, and about two or three inches away from the hem run a piece of lace insertion, which, to look well, should be the same width as the hem. Cut the lawn away from underneath the insertion and your curtains are finished. These curtains are most inexpensive and are very appropriate for the dining-room and bedroom. They will launder beautifully.

Mrs. J. S. K., Pennsylvania.

Take your scrim and cut off a piece ten and one half inches deep for your top curtain. A hem should be made at the top, for the rod to slip through, and at the lower edge of the curtain the hem should be one and one half inches deep. Then cut the remaining piece of scrim down the center.

The two long pieces will make the straight long curtains which hang on a rod concealed under the edge of the upper curtain. These long curtains should be hemmed at the bottom and up the inner sides. The hem should be the same depth as the one on the upper curtain. The hem at the top of these two curtains should be deep enough to run the rod through.

Mrs. M. E. G., Illinois.

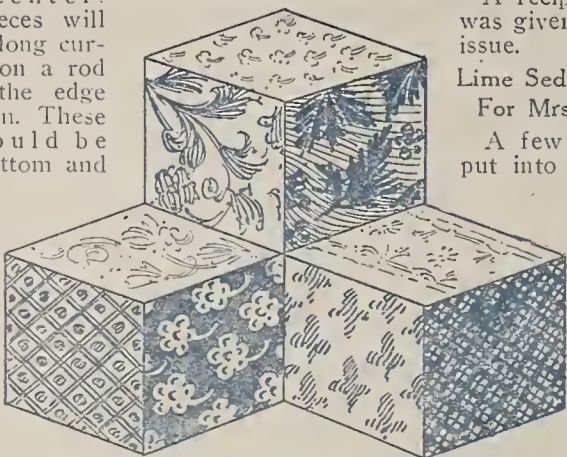

Block design contributed by Mrs. S. R. D., of New York

Description of Box Quilt Pattern For H. A. D., Ohio

Three colors are required for the box quilt. Dark and medium dark for the sides of the box and light for the lid. Cut your material in diamonds of any preferred size, and sew the dark and medium dark pieces together in a zig-zag strip the length you wish the quilt to be; then fill in the corners with the light diamonds, these make the tops of the boxes. Piece another strip like the first and join it to the first strip with the dark and medium dark against the light and so on across the quilt. Even the outside edges with half diamonds. Be careful to keep all the dark pieces on the same side so that the shadow of the boxes will fall evenly. To go with light gray I would suggest dark gray for the shadow side of the box and delicate pink for the lid.
E. N., Oregon.

For Mrs. S. A. G., Ohio

To turn sweet cider into vinegar, add a pint or more of sweet milk to a barrel of cider.
Mrs. O. F. W., New York.

Another suggestion from Mrs. M. B., Kentucky, is: Set the sweet cider in a jug with a thin cloth over the top and set the jug in a warm place.

For Mrs. R. H. T., New York

A recipe for Graham crackers was published in the Household Department in our March 25th issue.

To Tan Small Furs For Mrs. R. M. S., Kentucky

The following is a good method for tanning skins with the fur on. For fresh skins, salt at once, before attempting to remove blood or flesh. Let stand several hours, remove the salt and scrape the skin thoroughly. While scraping, the skin should be placed over a log or beam and the flesh scraped until the grain of the hair is reached. The tail should be split to the end and given the same treatment. Now wash the skin in strong soap suds into which a quantity of borax has been dissolved. Rinse six times in clear water and when partly dry shake and manipulate the skin with the hands to soften it. Again scrape the interior with a dull knife to remove all the water.

To make the tanning fluid, stir three ounces of sulphuric acid into one gallon of rain-water and dissolve as much salt as possible in the solution; and it is ready to apply. Place the solution in a shallow vessel and immerse the flesh side of the skin several times, allowing a few minutes between times. Wrap the flesh side in and allow it to remain thus for twelve hours, after which stretch it on a board, tacking the edges. Allow it to remain eight hours and after some time the interior will become white. Right at this point, it must be greased well with olive-oil, neat's-foot oil or butter. Remove from the board and hang in the shade to dry. While it is drying, work it occasionally with the hands. Too much work of this nature cannot be applied. If Mrs. R. M. S. will follow these directions, I am confident she will be pleased with the results.
A. H., New York.

For Mrs. E. R., Oklahoma

A recipe for head-cheese was given in our April 10th issue.

Lime Sediment in Tea-Kettle For Mrs. T. T., Kentucky

A few porcelain marbles put into the tea-kettle will help considerably in collecting the hard substance that forms. I keep six or more marbles in my tea-kettle. They become heavily coated and the substance can be very easily cracked off of them.
H. A. M.

Reo \$1000

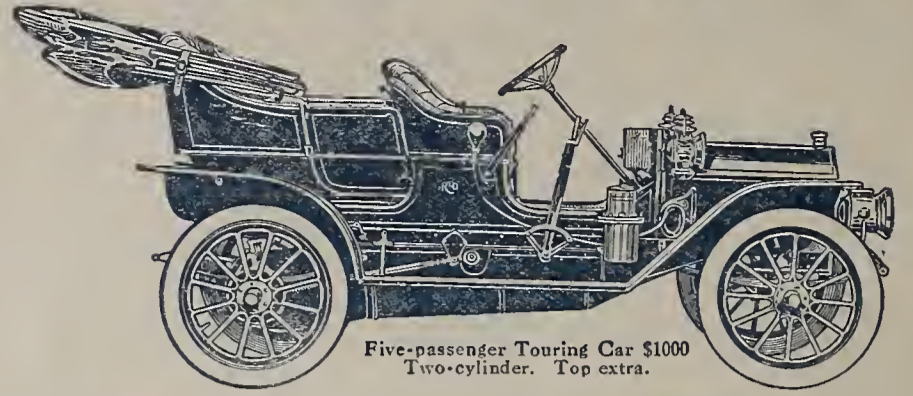

Five-passenger Touring Car \$1000 Two-cylinder. Top extra.

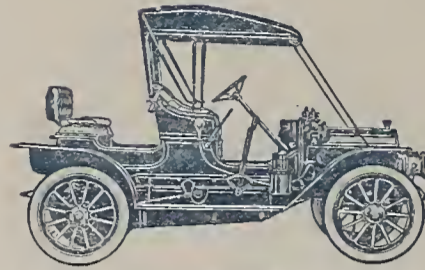

Roadster with emergency seat and top \$1000

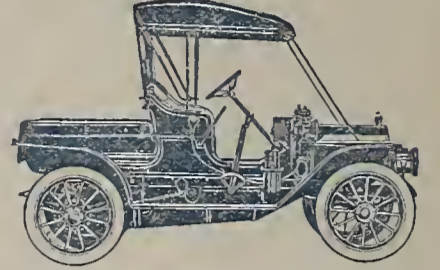

Delivery Car fully equipped with top \$1000

The Reliable Convertible Car

Whether you use your car for business or pleasure, the one thing you want first of all is to be sure of getting there and back. That is what 25,000 Reos are doing to-day and every day of the year.

The Reo has proved this over and over again—in Endurance Contests (where it has always won perfect scores), but most particularly in private use. A Reo owner always knows positively that he will reach his journey's end on time—it makes no difference what kind of weather or roads, snow, rain, mud, good roads, bad roads, or what kind of hills.

You can change your Reo from the roomy touring car that you see in the picture above to a roadster or delivery car in two or three minutes. It is the handy car for work or pleasure, or both.

Reo Runabout \$500

This single cylinder car is the most reliable runabout under \$1000. The ideal car for the busy man who has lots of getting-about to do and wants to keep his costs down.

With the folding seat (\$35 extra) it easily carries four passengers.

Write immediately for catalogue and address of Reo dealer nearest to you. He will tell you all you want to know about Reo cars.

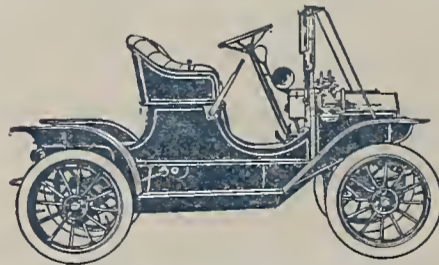

Reo two-passenger Runabout \$500. Top and Windshield extra. Extra seat holding two \$35

R M Owen & Co

Lansing, Michigan

General Sales Agents for

Reo Motor Car Co

Licensed under Selden Patent.

It is to your advantage to mention Farm and Fireside in writing to advertisers. Farm and Fireside folks get the very best attention.

Freight Prepaid on "Breco" Rubber Roofing

Don't spend a dollar for roofing until you have seen and tested our old reliable "BRECO"—guaranteed waterproof, fire-resisting, durable Rubber Roofing. Made by our own special process, of long-fibre wool felt, saturated in asphalt. Heavily coated on both sides. Free Cement and Special Roofing Nails included in each roll—Hammer lays it—Use it on ALL Buildings.

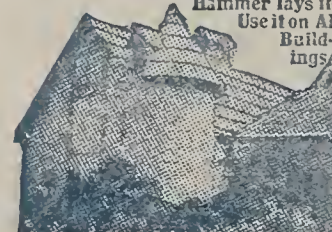

Send for Free Samples and Booklet—Get these samples of 1-ply, 2-ply and 3-ply roofing. Put them to every test you can think of and prove to your own satisfaction that "BRECO" Rubber Roofing is the highest quality roofing on the market. We give the Longest Guarantee. Send for samples or order now on our strong guarantee of satisfaction or money back. We pay freight to all points east of the western boundary line of Minnesota, Iowa, Missouri, and north of south line of Tennessee. Don't delay ordering; these special prices may not be offered to you again. Take advantage of them and write now, today—THE BREESE BROS. CO., Roofing Dept. 24 Cincinnati, Ohio

Lowest Factory Prices

Freight Prepaid on 100 lbs. or more	
35-lb. Roll—108 Sq. Ft.—1-Ply	\$136
45-lb. Roll—108 Sq. Ft.—2-Ply	186
55-lb. Roll—108 Sq. Ft.—3-Ply	226
Order today, or write for Samples and Booklet	

EASTERN EDITION

LIBRARY
RECEIVED
MAY 23 1910
U. S. Department of Agriculture

FARM AND FIRESIDE

THE NATIONAL FARM PAPER

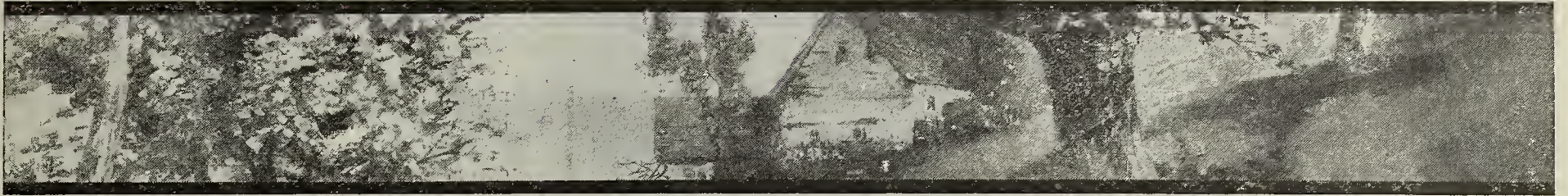

ESTABLISHED
1877

MAY 25
1910



ALONZO KIMDALE

Another of Dr. M. P. Ravenel's Fine Articles in This Issue

A Visit With the Editor

IN OUR issue of March 10th the editor suggested to his readers that public opinion is growing and developing in the matter of the relations of the railways and waterways. We have now reached the stage in this development at which the National Waterways Commission feels called upon to say that the water traffic of the nation should be protected against railway competition of the sort which has destroyed water-borne commerce in the past.

Inasmuch as the first demands for such restraints upon competition were voiced within five years, the question "What is Conservatism?" was made the title of the editorial.

This elicited the following letter from the general passenger and ticket agent of a mid-Western railway:

EDITOR FARM AND FIRESIDE:—

I have just finished reading the editorial, "What is Conservatism," in your issue of March 10th, and while the subject is fresh in my mind I beg your permission to mention a conversation which occurred between the captain of a Mississippi River steamboat, running regularly between St. Louis and Memphis, and myself, while on a recent visit to the former city. Having read with much interest President Taft's promise to do all in his power to secure a twelve-foot stage of water at all times of the year for the Mississippi, even to recommending a national bond issue of thirty millions of dollars for that purpose, and desiring to obtain the views of a practical riverman on the subject, I requested the captain to give me his opinion of the proposition. This is in substance his reply: "There is absolutely nothing in it but a political 'jolly' to the million or more people inhabiting the territory to be affected and very fat pickings for the contractors who expect to do the work. There is always a good stage of water between St. Louis and Memphis, so that we need never miss a trip: Our freight rates are as low as those of the railways and our time is as good, yet we cannot secure any considerable portion of the traffic, for the simple reason that the great majority of shipments are in car-load lots, loaded on the sidings in the big factories at one end of the line and unloaded in the warehouses or other factories at the other end of the journey, while every pound of freight which we carry must be trucked and hauled and trucked at each end of the line.

"Steamboating was all right before the advent of the railways, but it has been on the decline steadily since they came, and nothing within the power of our well-meaning President or of the Congress can check it."

Evidently the steamboat captain thinks the whole business of waterway improvement a delusion and a snare.

Impliedly, our esteemed correspondent agrees with him.

Both are specialists, it may be assumed. The one devoted to water traffic, the other to land haulage.

If they are right, we should stop improving the rivers at once. We should make up our minds that our products must be forever and ever hauled from the interior to the sea by railways exclusively and that the rivers, that are so great a part of the transportation systems of Europe, are in this country useless.

If they are right, the people who are so earnestly advocating waterway improvement are befooled and deluded.

To the farmers of the nation, this matter is of the utmost moment. For it comes at the very time when the railways seem to be breaking down. To be sure, the roads seem to be handling the business fairly well just now, but we must not forget that three and a half years ago now, the freight-yards were so full of cars that they were paralyzed. The homesteaders of the Northwest froze in their houses because the railways could not haul them fuel, it took on the average a month to get a car of freight past the Chicago yards, wheat rotted in the fields and beside railway spurs in the wheat regions for the lack of cars, cotton rotted beside warehouses crammed full because of freight congestion, and live stock were finished, grew overripe and went back into the money-losing state on thousands of farms because the railways were stalled, broken down and despairing.

It was in this crisis that Mr. James J. Hill said: "In view of the inability of the railways to move the heavier classes of freight, there has been no subject before Congress for twenty years which interests so many people, and will prove so great a benefit to the entire basin of the Mississippi and Missouri rivers, as the deep channel from St. Louis to the Gulf of Mexico."

It was at this time that railway presidents everywhere purged themselves of blame for the prostration of the nation's freight business by asserting that the railways were inadequate to the job of handling it. It was Mr. Hill who said that the immense sum of \$5,500,000,000 was needed to make the railways equal to the traffic then existing, to say nothing of increased and increasing tonnage.

At a time just subsequent to this railway breakdown I was engaged in writing the series of magazine articles since expanded into a book and published under the title "American Inland Waterways." When this writing was doing, the freight situation was excellent. There was no longer a congestion. Things were running on swimmingly. Yet the circumstances compelled the statement that this good condition is but temporary, and that the business which the railways have done so much to create is sure to break them down again. The flood tide of prosperity will bring a freight situation that for the interior states, and in large measure for all states, must cure the evil by curing prosperity.



This was three years ago. The words have been quoted with more attention in Europe than in America. But only the other day Mr. Hill submitted to an interview, in which he was quoted as saying that we to-day face a situation similar to that of 1906-7, only far worse. If he is correctly reported, he foresees conditions toward which the producers of freight in the interior of the continent may well look forward with concern. And he now says that the enormous sum of \$9,600,000,000 is needed to place the railways in position to handle the business and that it cannot be done in less than six years.

If our steamboat-captain friend and our esteemed correspondent are correct, we must abandon the waterways just at the time when railways are definitely proven insufficient, and also at the time when foreign nations are proving more clearly than ever that river and canal haulage is far better, far cheaper and far more efficient than railway haulage for the heavy, low-grade freight that makes the freight congestion.

The fact is, there is every reason for believing that the best interests of the railways as well as of the people demand such legislation as will make the waterways again the bearers of a great part of our tonnage.

Such legislation has been devised and well worked out in Germany, for instance, where water commerce is enabling German freight to reach the markets of the world at rates which are putting the British manufacturer gradually at a disadvantage, to the great damage of the British railways.

The steps necessary are few, though neither simple nor inexpensive.

The railways must not be allowed to make war on waterways. In Germany the railways are not allowed to charge less than one hundred and twenty per cent. of the water freight rates over competing lines. This law may not be a proper one for us, but it is a hint at laws which will take the knife of the railway from the throat of the boat line.

The railways must not be allowed to monopolize water-fronts of cities and docks. This is one of the ways in which the American roads have banished the traffic from rivers and lakes.

The cities must provide docks and wharves furnished with handling machinery and with other agencies which the shippers expect and which the railways give. The old-fashioned levee down which freight is rolled, and thence up a gangplank and under an overhanging deck is too costly a thing for these days. Freight, where it exists in large volume, must be handled by machinery, and boats must be built so as to save the last fraction of a cent per ton in loading and unloading.

The rivers and canals must be deepened as required. The engineers must work out standard depths and widths so that barges may be transferred from waterway to waterway as cars are now run from railway to railway on standard-gage tracks.

The railways and waterways must be operated harmoniously, freight must be exchanged and a thousand problems worked out to the end that that harmony between waterway and railway may be attained which is for the best interests of both and of the people, and which the French statesman, M. de Freycinet, described in an utterance which states the position of the French government on this matter. "It is conceded," said he, "that the waterways and the railways

are destined not to supplant, but to supplement each other. Between the two there is a natural division of traffic. To the waterways gravitate the heavy commodities of small value which can only be transported where freights are low. In procuring for manufactures cheap transportation for coal and raw materials, they create freights whose subsequent transportation gives profit to the railways."

All these things will cost money—a great deal of money. But while the railways are spending five billions or ten billions, as the case may be, on every dollar of which we shall be obliged to pay interest in freight rates and passenger fares—and justly so—the people may well pay out as many millions as may be

required to prevent industrial strangulation and to make great free highways for the serving of this great interior of a continent.

In a few years from now, after another great transportation crisis, we shall be willing to pour out our money for waterways. Better far to foresee and plan. For we shall fail if we do not adopt the methods that have made the waterways of Europe the handmaidens of the railways in freight service. The old ways will not do. Neither will the old boats, nor the old docks and wharves.

But the oldest of all ways of moving freight—floating it in water—is still the cheapest and the best. The interior of no continent has ever reached full industrial development through land haulage alone. The present freight situation justifies the conclusion that such development is impossible.

And the blight of bad transportation, when it alights on us, touches the farms first. It was so in 1906-7, and it will always be so. The farmer originates "heavy low-grade freights." He is most interested in waterways.

Robert S. Hill

One Good Turn Deserves Another

We want you to help us introduce Farm and Fireside to your neighbors who are not now subscribers. We will make you this unusual offer. Get two people each to give you 50 cents for a year's subscription to Farm and Fireside. Send us the One Dollar, and in return for the favor we will send you Farm and Fireside for one full year without cost after your present subscription expires. (If you are not now a subscriber, your own subscription will be entered for one year without cost.)

FARM AND FIRESIDE, Springfield, Ohio.

FARM AND FIRESIDE

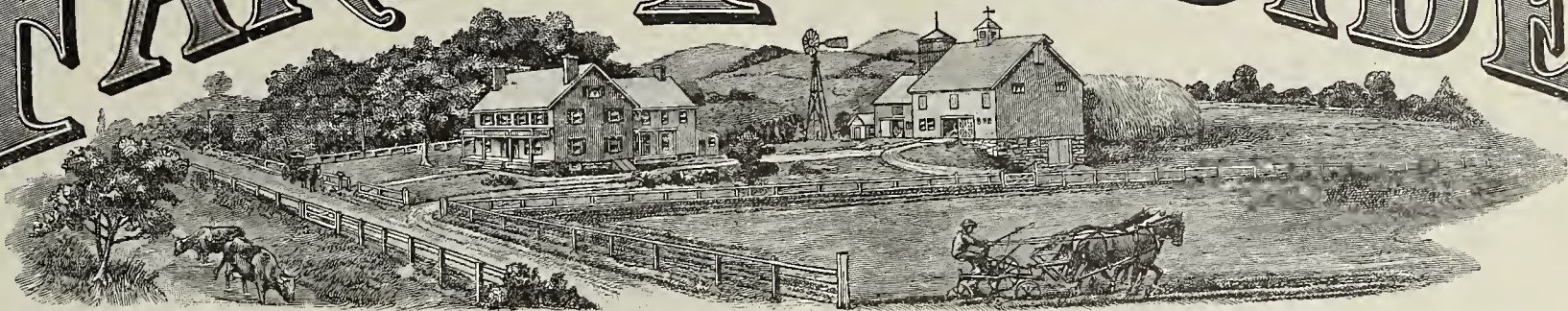

Vol. XXXIII. No. 16

Springfield, Ohio, May 25, 1910

PUBLISHED
SEMI-MONTHLY

Shying and How to Cure It

Another Lesson in Horsemanship—By David Buffum



Standing at Attention

SHYING is a very common as well as an extremely objectionable vice, completely spoiling many otherwise valuable horses—for there is neither pleasure nor safety in driving a bad shyer. It is first caused by genuine fear. In the majority of instances—in fact, always, except in the case of nervous or hysterical shyers—had the horse, from the first, been gradually

accustomed to the objects he fears and shown that they would not hurt him, he would never have become a shyer.

The average colt, when being broken to harness, is constantly meeting some object that—in greater or less degree, according to his nature—excites his fear. Perhaps it is only a stump or a rock or a log by the roadside half concealed by the grass. A good horseman, in such a case, will be very patient, allowing the colt to stand still for a moment and look at the object of his fear; then moving him gradually a little nearer and convincing him that his fear is unfounded. Every such experience renders the colt less nervous and timid, for it increases his confidence in his driver.

But, too often, the essential factors in the case are overlooked. The driver, knowing that the colt does not fear such objects in the pasture, foolishly assumes that he, therefore, ought not to fear them in the road—forgetting the entire novelty of the position and that, in the strangeness of his new experiences, the colt's excited imagination readily transforms the log or stump into some great beast, ready to spring upon him. So the colt, instead of being shown his error in a rational way, is presently engaged in a foolish tussle with his driver, and it is ten to one that, before it is over, the colt, in some measure, has got the best of it. This needless tussle and his partial victory he will afterward associate with the object of his fear; and he will not only feign terror of it when he has really got over his fear, but will be more likely to find fresh objects to shy at.

To cure the shyer when his fear is genuine, there is no way but to do what should have been done in the first place; begin all over again, be both patient and resolute, and properly accustom him to all objects that he fears. When it is certain that he is only feigning terror, coercive measures must be used, for it is absolutely necessary that, in some way or other, the horse be got by the object. He will never be good for anything if allowed to turn around and retrace his steps. In many cases I have found a good whalebone whip and a four-ring bit all the adjuncts that were necessary. But, generally speaking, the controller, described in my last article, affords the best means of treatment, for the horse is obliged to stand perfectly still when its pressure is applied, and when it is released he is frequently ready to pass quietly by. With reference to the whip, its use is so often abused that it is never to be recommended except to those who know exactly when and how to use it.

Fit the Treatment to the Case

The fact that the fear is sometimes real and sometimes assumed makes it especially difficult to give detailed instructions to fit any and every case. It is essential that the trainer know the one from the other and I find it about impossible to describe the actions of the horse in each instance so that my reader can distinguish the difference. And yet there is a difference, and a difference that any one who has had much experience with horses can readily perceive. In the assumed fright, the horse is acting a part and his actions do not ring true.

It often happens that a horse fresh from the stable will shy at an object that he would scarcely notice when tired. This does not always prove that he is

Copyright, 1910, by David Buffum.

shamming—nor is it to be confounded with neurotic or hysterical shying, of which I will speak later. When fresh, his nerves are keyed up to such high tension—are all on such a tiptoe of expectancy, as it were—that the impression is telegraphed to the brain with lightning rapidity and an involuntary shrinking is the result. Later, when he is tired, the nervous action is slower.

Although, as a general rule, it is preferable to drive a horse by an object that he fears rather than to lead him, there are a great many cases where the latter is necessary and it is highly important to know how to do it. Strangely enough, this thing, which seems so simple, is almost invariably done in the wrong way. Under the impression that the horse needs coaxing and persuading, the ordinary driver will stand facing him and grasping the two reins close to the bit, walk sideways, constantly speaking words of encouragement as he endeavors to "work" the animal by the object. No wonder that the horse believes the occasion a momentous one. From his driver's behavior he is led to believe he must nerve himself to pass some terrible object.

Now the right way is this: Grasp the near rein in your right hand about a foot from the bit. Now, holding it firmly, but looking right before you and paying no apparent attention to the horse, walk on in a nonchalant way—just as if the circumstances were nothing out of the ordinary and you assume, as a matter of course, that your horse will follow quietly. If your previous attitude toward him has been such as to win his confidence, he will do so, for he is taking close note of your behavior and is satisfied by it that he has nothing to fear.

It not infrequently happens that people owning highly-bred horses are puzzled and annoyed by a vice—usually shying or bolting—which is manifested only occasionally. A horse, for instance, is thoroughly accustomed to automobiles and you have driven him on perhaps twenty occasions when he has shown no fear of them. But on the twenty-first he evinces the most extreme terror, shying badly or perhaps even bolting over the roadside wall. That the fear is genuine is evident to an experienced horseman and the vice is tenfold worse in that we never know when to expect it.

Horse Hysterics

This vice (for which the horse is not to blame) is really an hysterical outbreak, and though the shyer of this class may be held in check at the time by some such device as the controller, we must, in order to effect a real cure, go beyond any mere coercive treatment and look for the cause of the trouble where it really is—in the nervous system. The way in which this nervous disorder operates may be illustrated by a phase in human nature familiar to all.

A boy is afraid of the dark, although he knows his fear is foolish and that there is nothing to hurt him. He goes into a dark cellar twenty or thirty times, always holding his unreasoning fear in check by an effort of his will. But there comes a time when, his nervous mechanism not being in as good order as usual, his fear gets the best of him and he makes a mad rush for the door. He knows there is nothing in pursuit, but he has lost his self-control and he is in as abject fear as though menaced by a real danger.

The case of the neurotic shyer is of like kind. The horse has learned that the object he once feared will not hurt him, but the association of ideas is such that a slight effort of his will is necessary, each time he passes it, to hold his fear in check. But on some day, when his nerves are a trifle out of order, even this slight effort becomes impossible.

I have owned and also treated for others a number of neurotic shyers and bolters, and they were all horses that had a large percentage of warm blood. The trouble is not one that cold-blooded horses are liable to.

This vice is of so peculiar a nature and so many horses are never cured of it—at least during the best years of their lives—that its cure might seem, at first blush, a difficult matter. But, once understood, there is no trouble in effecting a cure and the treatment is extremely simple, consisting only in judicious feeding accompanied by work—work, the natural and God-appointed medicine that has reformed more vices and taken the nonsense out of more horses and men and women than any other agency since the world began. I do not mean excessive or unduly hard labor, such as breaks the spirit of a horse, nor occasional severe journeys, followed by a period of rest, but daily, unremitting work in harness or saddle or even light farm

work, such as plowing old ground, if the horse is large and strong enough.

That the reasonableness of this treatment may be fully understood, let us look, for a moment, at the nervous system of the highly-bred horse and the purpose it serves. This nervous system—far more highly developed than in the cart-horse—is what gives him his reserve force, his staying power. It is not bone and sinew that keep him going at the end of a hard race, but nervous energy. The common horse gets tired and quits; the thoroughbred also gets tired, but he keeps on.

This wonderful piece of mechanism gets out of order in a horse dawdling in stable or paddock. But give the horse plenty to do and his nervous machinery again becomes healthy and runs smoothly.

Treatment Through the Feed-Box

The feeding in neurotic cases has also a direct bearing upon the end in view. The chemical element that nourishes the nervous system is phosphorus. Therefore, when the nervous system is performing its proper work, there is little danger of giving the horse a food too rich in this element; but when the nervous system has no chance to spend its energy, the excess of nerve-food becomes hurtful, rather than beneficial. The horse-foods which contain the largest percentage of phosphorus are oats and barley, and that is why these grains put so much life into a horse. Next in order comes Southern corn. Northern corn contains little phosphorus, but a large amount of carbon, and hence it is a sleepy food, making a horse fat and lazy.

The knowledge of these facts should be turned to practical account in feeding. In the earlier stages of treatment the neurotic horse should be deprived of a portion of his oats, substituting a proper ration of Northern corn. Usually a slight change in this respect is enough to produce the desired result, and in a short time, as treatment progresses, his full ration of oats should be restored. For he will need an abundance of life-giving food if given the constant work that his case requires, and it must be remembered that it is upon work that we chiefly depend for a cure. The dieting simply slows up the nerve-machine a little and relieves the strain till the more important treatment begins to have its effect.

I have dwelt a little longer on this matter of shying, because it is rather more complicated in its nature than some other vices and not to be reached by quite so direct methods.

Pulling back on halter is a very provoking vice. It always originates in the horse breaking (usually by accident) a weak halter-rope, after which he will try every new halter and every new place where he is tied. Not only that, but a confirmed halter-puller, after being tied with a halter that he cannot break and standing quietly for weeks in the same place, will suddenly and with no apparent reason make a fresh attempt to break away.

The first thing to do, of course, is to have a strong halter, and the rope should be of extra length. If the horse is then tied very high, he will soon give up the habit. I have frequently tied such horses to a ring attached to the ceiling—though this extreme height is not really necessary; a foot or two above the horse's head is all that is needed. The ring should be well forward of the head of the stall and the rope just long enough to permit the horse to lie down. If placed immediately over his head, it will allow him to back too far out of his stall, where he may kick his neighbors or otherwise get into mischief.

Another good way is to have a long rope on the halter and have the hitching-ring exactly in the middle of the front of the stall, pretty high up. Carry the end of the rope through the ring, back between the horse's fore legs and tie it rather tightly around his body, having the knot exactly underneath. He will not pull back many times with this arrangement. But while an excellent lesson to the horse is thus administered, the method is not very convenient for regular use and the single strong halter-rope, tied high, as recommended above, is more satisfactory as a steady thing.

The methods I have here recommended for the cure of different vices are those which I have found the best and most efficacious; they are simple and can be applied by any one else as well as myself. But, however carefully I may explain their working, much, after all, must depend on the trainer. I feel that I cannot urge too strongly or too frequently upon my reader the necessity for patience, resolution and self-control.

Western Canada Demands Government Elevators

How Organized Farmers Make Themselves Felt—By Arthur Hawkes

In a recent issue Mr. Hawkes told how Western Canada inspects her grain and how her organized farmers have secured recognition of their interests in the process. Here is a sketch of the whole cooperative grain-growers movement. If any farmer on this side of the border is dubious about the benefits of cooperation in his business, he ought to be converted by this account of Canadian success. EDITOR.

THE farmers up in western Canada are finding their feet quicker than many of their brethren in older communities. That is partly because their country is new and partly because there has hitherto been a unique community of interest over an enormous extent of territory. For a thousand miles between the Lake of the Woods and the Rocky Mountains the country is principally devoted to wheat. The surplus crop, which is now well over the hundred-million-bushel mark, goes to the market through Port Arthur and Fort William, at the head of Lake Superior; so that the farmers have been able to watch it, as it were, travel clear out of the country.

That means that they have observed all the processes of sale and resale. They have kept tab on the commission agents, the elevator men, the steamship companies—on everybody, in fact, who, from being the honest servant of Agriculture, is tempted, by the very magnitude of the business and by the comparative absence of the farmer, to try the game of being the Master of Agriculture. Many people imagine that the farmer is a chronic grumbler. He is nothing of the kind—which is wonderful, considering how many things there are to make him kick.

Well, the farmers of Manitoba, Saskatchewan and Alberta have been alive to their own conditions and prospects. Not all of them have become apostles in their own behalf; for it is the bane of farmers everywhere that they have never learned to look after their collective interests. One organization after another has come up like a Jonah's gourd, and has finally died of acute anemia. They have somehow missed the business basis that is essential to the success of every movement that is concerned with the business advancement of a large section of the community. The farmers, who are the most vital element in the national life, are the last to combine for their own defense.

In western Canada the defect is being remedied, in a way that assures a permanent success, by organizations of grain-growers originating with the formation of the Saskatchewan Northwest Grain-Growers' Association ten years ago. For one thing, out of the movement has grown a great business that is making money—it is the biggest grain commission firm in the country. There is a danger in this, of course; but it arises from a condition that was not foreseen, and that can only be remedied by act of Parliament. There is a Grain-Growers' Association in each of the provinces of Manitoba and Saskatchewan, and the United Farmers of Alberta as their equivalent in that province. They are independent, but united; different,

but alike. They include every branch of agriculture in their endeavor.

They have done two things which entitle them to honorable distinction among farmers and public-spirited men everywhere—they begot the Grain-Growers' Grain Company, and they have produced a weekly organ that promises to be one of the most powerful organs of operative opinion in Canada, and I say that as an old newspaper man of pretty wide experience. They have also brought within the realm of practical politics the government ownership of elevators. Let me sketch each of these achievements.

The grain-growers' movement originated, to a large extent, in a wide-spread dissatisfaction with the grain-producers' position as under-dog to the grain-buyer. If money could be made out of the transfer of grain from the grower to the miller, why should not the farmer do his own selling by agents whom he con-

two or three plutocrats getting possession of a vast business, anyway.

The company, running just like any other commission firm, in the third year of its age did more business than any other similar firm in Western Canada. In the fourth year, 1909, the other fellows cut their commission charges in two, to try to beat the grain growers off the field. But annihilation could not be accomplished that way; for, meantime, the company had used some of its profits to establish an organ for the association whose child it was.

The Grain-Growers' Guide came into existence as a monthly. It was edited by amateurs and bore many marks of amateurishness. But it had an assured constituency; it met a need and it was handled with conviction. It attained a circulation of thirteen thousand, and, last fall, the directors made a weekly of it. It is now edited by a young newspaper man who is as earnest as he is able at his work.

The associations have not neglected the propagation of their principles by what the Apostle Paul called the foolishness of preaching. After last harvest I found myself in the midst of an automobile campaign that extended over a territory as big as the states of Ohio, Indiana, Illinois and Iowa—a campaign of meetings, two and three a day—that could only have been undertaken by men who were not small about money matters, and who were fully seized of all the essentials of a great public movement of the first importance. I could not help contrasting the scope, strength and success of this movement with the feeble struggling toward coherence with which I was familiar in that same section of country away back in the eighties, when we were wondering whether we were going to have a country or not. Early in February of this year the Annual convention of the Saskatchewan Grain-Growers was held at Prince Albert, when six hundred farmers discussed with marked ability and eloquence the things that make for their own peace and justice. One of these was the affiliation of the eastern organization, the Dominion Grange, with the western association and the amalgamation

of all the agricultural associations under the Canadian Council of Agriculture.

But the immediate program of the grain-growers is the government ownership of local and terminal elevators. The justification for the demand is an unfair exploitation of the farmer, both as a seller and a storer of grain. If he must sell to a buyer on the street or take his load home again, he is compelled to accept what is offered him. If he is able to store, he has no guarantee that the bin which should be his really holds his grain. In fact, it is more than asserted that over and over again, when the farmer has innocently believed that his good wheat was snugly waiting for the inevitable rise in the market, it has been sold and delivered to meet the engagements of the elevator man; and when the farmer has decided to sell, the wheat that went out as his was grown in somebody else's field, was of an inferior grade to that

[CONCLUDED ON PAGE 12]



"The World is Watching"—An Expressive Cartoon Published in the Grain-Growers' Guide
The Manitoba, Saskatchewan and Alberta Grain-Growers Hold the Balance of Power

trolled as much as he controlled his farm help? So, after much skirmishing around, the Grain-Growers' Grain Company was formed, as an offshot of the association; and farmers were invited to sell their grain through it, the profits being returned to the sellers according to the amount of their sales.

Many a mickle makes a muckle, and a cent a bushel on millions of bushels meant large fortunes for men who did not need such a vast amount of gray matter for the purpose, either. But a Grain Exchange law, that may not have been drafted with the possibility of a Grain-Growers' Grain Company in view, was invoked; and it was ruled that a concern of this philanthropic character could not live in the purlieu of the Winnipeg Grain Exchange. The shareholders in the Company, therefore, found themselves a money-making concern against their will. The holding of each member had been limited to four shares of twenty-five dollars each; so there was not much likelihood of

Agricultural Education Must Make Good

A Warning Against Faddism—By Edwy B. Reid

AGRICULTURAL education has within the past few years received more attention than it ever did before and the nature of this attention has taken the form of its introduction into the country and high schools. The study of agriculture has been introduced in greatly varying ways and with as varying results. In some instances much originality of presentation has been exhibited which has resulted in benefit to the students, but the tendency of many schools, or advocates of the introduction of agriculture into the rural and high school, is to go too far.

This tendency can be finely illustrated by the results of the introduction of vertical writing into the schools only a few years ago. Some faddists took up with the idea that vertical writing was the only hand that should be taught and consequently many teachers became enthused with the idea that they were doing humanity a great good by teaching "a handwriting that was beautiful and legible, etc." It took the country by storm, and as a result thousands of people in every state are to-day poor penmen because of the fad. While the vertical handwriting was, indeed, likely to be more legible, it was very slow and took up more space than did slant hand. But the main point is that the fad, like all fads, did not stick. Children's handwriting was spoiled in changing and only those who changed back to the slant hand by their own efforts are good penmen.

Do not let us make a fad out of the teaching of agriculture! It will be an easy matter to do. We have got to grow into the teaching of agriculture in the high schools and country schools. At present we are lacking the main requisite for teaching agriculture in these schools and that requisite is enough teachers qualified to teach the work. The ordinary places where

teachers are ground out nowadays are not usually fitted with apparatus and instructors to teach the teachers the rudiments of agriculture. Only a few normal schools give their students a course in agriculture that will fit them at all to handle the work. If the work is attempted by these teachers, agriculture in the schools is doomed to the same failure as the vertical-writing fad.

I am interested in the introduction of agriculture into the schools, but I do not want to see the project fall through in a few years and be dubbed a fizzle. The child ought to obtain a goodly amount of cultural training along with the professional work. He must not be deprived of many of his high-school studies now offered in order to introduce the agriculture and manual training. The tendency would be to fit these children who were given an over amount of professional studies only for these professions. In a few years we would have conditions worse than they are at present, the people would be more widely separated than they are now, simply because of a narrower education based to too great an extent on the professional and not enough on the cultural and broadening lines.

The place that agriculture should occupy in the city schools, in my opinion, is as an elective study—one which will tend toward teaching the children that agriculture is as high a science and as honorable a calling as any. When agriculture is taught in the rural high schools and rural common or graded schools, the problem becomes different, as there we hope to find more children who will be directly interested in agriculture, as a preparation for their life-work. But even here caution must be exercised, or the pendulum will swing to the extreme and the other necessary studies will be neglected to the detriment of the child.

Michigan is hurrying to the front with teachers that will be more or less equipped to teach the rudiments of agriculture in the country graded schools, the real place where the most good is to be done. The normal schools at Mt. Pleasant and Kalamazoo now train teachers in elementary agriculture. The County Normal Training Classes, organized for county or country teachers are also studying how to train their future students in the science in which all country boys and girls should be interested. Then, higher up, the agricultural college is giving attention to special preparation of young men to teach the higher branches of agriculture, physics, chemistry, botany and allied subjects in a way that will apply these sciences directly to the farm—this in addition to the training they receive in the regular branches of agriculture. Of men with this extra good training, there are now six in the state giving excellent service.

Michigan is making haste slowly, as would be expected of the state that was the first to take up the work of scientific agriculture, but she is going ahead with it in a way that promises success. For instance, in the county normal training schools, of which there are forty-eight now at work, nine weeks are given to the study of teaching of agriculture and Nature study. In 1893 less than one half of one per cent of our six thousand seven hundred county-school teachers had been trained especially for their work. This year there are about thirty-five per cent that have had county or normal training and most of these have had a slight training in teaching elementary agriculture. Next June there will be between one thousand and twelve hundred who will graduate from these training-schools or county normals and who will teach in our rural schools elementary agriculture and Nature study.

Driving Tuberculosis Out of Dairies

By Dr. Mazýck P. Ravenel

Tuberculosis suppression in general and the tuberculin test in particular are centers of controversy in dairy circles. What Doctor Ravenel says regarding the accuracy and harmlessness of the test is backed by the most thorough scientific investigations in America and abroad. His own distinguished work in this line entitles him to speak with unimpeachable authority. EDITOR.

THE Bang method for the repression of tuberculosis in cattle has been frequently written about and often described, but is still little understood by the public. The carrying out of the method depends so largely on the use of the tuberculin test that it will be necessary in this article to include a discussion of that test, also.

The Bang method was originated by Prof. Bernhard Bang, of Copenhagen, in 1892. Since that time it has been used extensively in Denmark and to a less extent in other countries. Its value has been thoroughly demonstrated. Most of the states in the Union which have laws for the suppression of tuberculosis recognize the method as a useful one and make provisions for its employment. However, the cost of labor in this country is so great that it has not come into general use and probably will not do so until our conditions are somewhat changed. It should never be recommended for cattle of low grade, but for thoroughbreds and grade cattle it is very useful. As well expressed by the late Doctor Pearson, the Bang method causes "no loss nor waste through repressive measures; such loss as occurs is caused by the disease itself and not by the destruction of animals that are still serviceable."

The method depends upon the well-established fact that tuberculosis is not inherited, as so many of the public believe, but is a disease due to a germ which gains entrance to the body, in a vast majority of cases, after the animal comes into this world. If consumption was inherited, the method would be useless.

In brief, the whole plan is to remove calves born of tuberculous mothers from their parents as soon as born, rear them in stables which are free from infection and feed them on milk from healthy mothers or else from milk which has been sterilized. In this way perfectly healthy animals are raised from mothers which are quite badly infected with tuberculosis.

In carrying out this general plan, the first step is to examine the herd physically. All cows which have tuberculosis of the udder or open sores are killed without delay. Having gotten rid of these manifestly diseased animals, the rest of the herd is tested with tuberculin. The essential feature is to separate the animals which react from those which do not react. The two sets of cattle should have separate pastures and separate watering-troughs, and, if possible, should have different sets of attendants. If the same attendants look after both sets of cattle, separate boots, overalls, etc., should be employed for the two stables, in order to avoid carrying infection from one stable to the other. It is obvious that those cattle which do not react should be removed to a stable which is new or else one which has been thoroughly disinfected. The non-reacting portion of the herd must be retested at intervals of from six to twelve months and the young animals born of tuberculous mothers must also be tested, and should any reactions occur, such animals be at once put with the infected portion of the herd. The milk from the reacting portion of the herd may be used as food for calves or swine, provided it is properly Pasteurized. Failure to see that this is thoroughly carried out results in disaster, as has been discovered at great loss to some herds. The Pasteurization of the milk from tuberculous cows must be under the care of a competent and conscientious man. It will not do to trust to commercial Pasteurizers without having them carefully tested.

By Pasteurization, we mean a partial sterilization. The two points which are important in Pasteurization are to heat the milk to such a point and for such a length of time that disease germs will be killed and yet the milk itself not be changed. The point which is usually guarded against most particularly is to avoid giving a boiled-milk taste. This can be accomplished by heating to one hundred and sixty degrees Fahrenheit for ten minutes. If a continuous Pasteurizer is used, where the milk is raised to a certain degree only for a moment, a much higher degree of heat, close to the boiling-point, should be employed.

The Bang method has been modified as follows: If it is not possible to give Pasteurized milk or milk from healthy cows to the calves, they may be allowed

to suck reacting cows, provided they do not show any marked tuberculosis or disease of the udder. In such cases, the calves must be left with the cows as short a time as possible and only during feeding. At all other times the calves are to be kept in uninfected surroundings. The nursing cows must be so confined as to prevent them from licking the calves, and unusual precautions must be taken in regard to the stalls. Calves so treated must be tested with tuberculin when they are six months old, before they are allowed to enter a healthy herd.

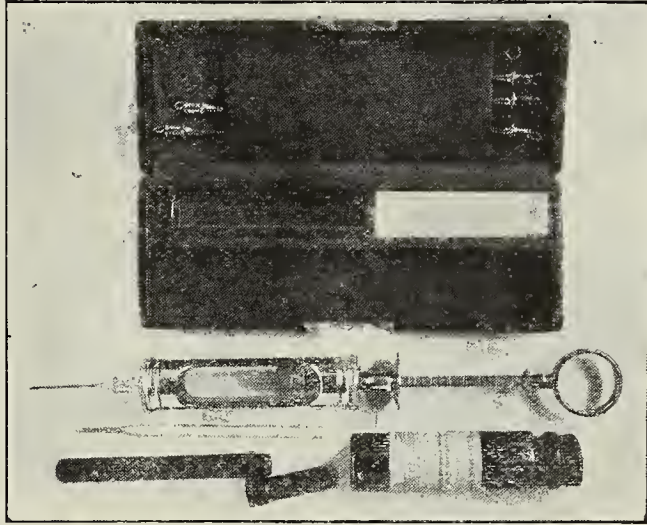

The Outfit for Tuberculin Testing

Above, case with extra syringe parts. Below, syringe, clinical thermometer and its case, and a bottle of tuberculin

I may give a few results, quoted from Professor Bang. Up to 1905, on sixty-six small farms with an average number

of twenty-nine head of cattle, there has been a change from highly tuberculous herds into healthy ones by the method just outlined. The number of reacting animals at the beginning was one thousand and forty-five, and healthy animals seven hundred and eighty. When the work was finished there were one thousand eight hundred and ninety-six healthy animals and no reactors. The testimony of the men who carried out this work indicates that it entails a great deal of attention, but a trifling expense.

As stated before, this method depends so largely on the use of the tuberculin test that a few words must be said about that, also. Tuberculin was discovered by Professor Koch through a series of very interesting experiments. It is made from cultures of the tubercle bacillus, which are grown on bouillon, containing an average of five per cent. of glycerin. An extract of the germs is made in the glycerinated bouillon on which they have grown, by heating. After the heating process, which requires from five to six hours, the germs are entirely removed by filtration through porcelain or earthenware. The liquid is then concentrated to one tenth of its original volume, and this constitutes the original tuberculin of Koch. For use it is diluted with a one half of one per cent. carbolic-acid solution, the usual dose being about one third of a cubic centimeter of the original concentrated tuberculin, or, in other words, about five drops. The tuberculin is injected under the skin of the suspected animal, and if tuberculosis is present, it is indicated by a rise of the temperature which begins about eight to ten hours after the injection, rising steadily to the maximum and falling gradually, the animal reaching its normal temperature as a rule within twenty-four hours after the injection.

The test is a simple one, but certain precautions are necessary to insure its accuracy. The animals must be accustomed to their surroundings. It is, therefore, better to test in the stable in which the animals are habitually housed. If it is necessary to test new animals just brought in, they should be allowed to become acquainted with their surroundings. The handling of animals during the test should be gentle and quiet. Animals which are in heat or are far advanced in pregnancy or those suffering from any disease should not be tested, as inaccurate results are likely to be obtained.

The test is not recommended for calves under three months of age. Animals in an advanced stage of the disease sometimes fail to respond to the test. As the disease is readily detected in such cases by physical signs, this failure to react does not impair the value of the test in practical work. The first step is to determine the normal temperature of the animal, and this is done by taking at least three preliminary temperatures, beginning about noon of the day on which the test is to be made. The injection of tuberculin is usually made about eight or nine o'clock at night, after which the animal is allowed to spend the night as usual, and the person making the test can obtain his own rest. After the injection, the taking of the first temperature should not be delayed beyond the eighth hour, and this must be followed by at least four other temperatures at two-hour intervals. In case any animal shows a rising temperature, the observations should be continued until the maximum is reached or a distinct reaction is recognized. If no rise of temperature occurs by the sixteenth hour after the injection, the observation may be discontinued and the test regarded as negative.

If the temperature shows a rise of two degrees Fahrenheit above the highest temperature of the day before and reaches a maximum of 103.5° Fahrenheit, the animal is regarded as being tuberculous. Those which approach this standard are to be regarded as suspicious and a retest applied after six weeks, always using a double dose of tuberculin.

The curve made by the gradual rise and fall of the temperature is quite characteristic, and one skilled in applying the test seldom is led into error even if the standard given above is not strictly adhered to.

Experience in every part of the world has shown that the tuberculin test is wonderfully accurate. It detects the disease in a very early stage. Statistics of 24,784 animals collected by the Bureau of Animal Industry show that the test is accurate in 98.39 per cent. of cases. It is

(CONCLUDED ON PAGE 12)

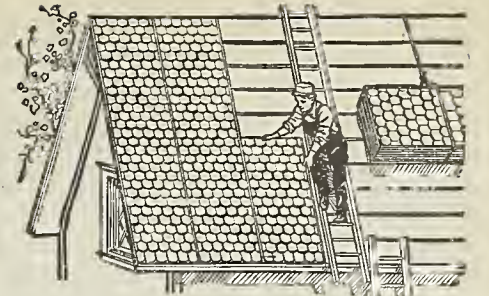

This Steel Shingle Roof Outwears All

An Edwards "Reo" Steel Shingle Roof will outwear four wood roofs and six composition or tar roofs. It will save from four to five times its cost. Furthermore, it is fireproof and reduces insurance rates from 10 to 20 per cent.

Edwards "REO" Steel Shingles

require no soldering. You can lay it yourself. Need only hammer and nails. Comes in stamped sheets of finest Bessemer Steel, 5, 6, 7, 8, 9 and 10 feet long, covering width 24 inches. Furnished painted or galvanized. Factory Prices—Freight Prepaid. We are the largest makers of iron and steel roofing and pay the freight on all Steel Shingles; Plain, Corrugated, V-Crimp Roofing; Imitation Brick Siding, etc. Write for free catalog No. 438 and ask about our \$10,000 Guarantee Bond Against Lightning. (14)

The Edwards Manufacturing Co. 409-439 Lock St., Cincinnati, O.

Monarch Hydraulic Cider Press

Great strength and capacity; all sizes; also gasoline engines, steam engines, sawmills, threshers. Catalog free.

Monarch Machinery Co., 603 Cortlandt Bldg., New York

Irrigated Land Buyers Guide—THE NATIONAL IRRIGATION JOURNAL.

Contains full, complete and reliable information on all public and private irrigation projects. Tells how to acquire irrigated lands, their cost, products, location, value, etc. Contains maps and comparative tables. Every bit of information relating to irrigated lands is contained in this magazine. The leading publication of its kind in the world, printed in colors, beautifully illustrated, special articles by authorities on irrigation. Published monthly. Golden Opportunities in the Golden West. This beautiful magazine 12 months and the 268 page book "Irrigated Land Buyers Guide" for one dollar.

NATIONAL IRRIGATION JOURNAL, 1111A First National Bank Bldg., Chicago

MAKE YOUR BICYCLE INTO A MOTORCYCLE

at small cost by attaching the ERIE MOTOR. This includes all parts so that anyone can make a strong, durable machine that will climb steep hills and run for 4c per mile. 1,000 in use. Sample sold at cost. Send 2c stamp today for catalog F.

Motorcycle Equipment Co., Hammondsport, N. Y.

100 Acres, \$2800 10 Choice Cows, All

Machinery and equipment included with this money-making farm; level fields cut 40 tons hay, soil especially adapted to corn and potatoes, pasture for 12 cows, ample wood, variety fruit, splendid 8-room house, big barn, stable, maple shade, R. F. D., cream sold at door, to settle affairs quickly, the low price for all is only \$2800, part cash; all details and traveling instructions to see this and others from \$800 up, page 73, "Strout's New Big Farm Catalogue No. 30," copy free. Station 2699, E. A. Strout, Union Bank Bldg., Pittsburg, Pa.

DON'T DIG WHEN IT'S QUICKER TO BORE

Standard Post-Hole Auger is the tool you need for fence work, tree planting, post-holes, etc., etc. Bore like a drill; dumps like a shovel. Get Our Free Catalogue 26 STANDARD EARTH AUGER CO. 1128 - 1134 Newport Ave., Chicago, Ill.

LEARN TO WRITE ADVERTISEMENTS IF YOU ARE EARNING LESS THAN \$25 A WEEK we can positively show you by mail how to increase your salary. Send for beautiful prospectus, mailed FREE. PAGE-DAVIS SCHOOL, Dept. 25, Chicago, Ill.

MINNESOTA HAS 1,000,000 ACRES open for HOMESTEAD ENTRY, offers Cheap Lands and Farm Employment. Write for literature and full information. STATE BOARD OF IMMIGRATION, Room 226, State Capitol, St. Paul, Minn.

MONTROSS METAL SHINGLES Most durable roofing sold. On market 21 years. Fireproof. Ornamental. Inexpensive. Catalog? MONTROSS CO., Camden, N. J.

Post-Cards Without Cost

We will send you the complete set of the famous 24 of Roosevelt in Africa post-cards if you will send us 10 cents each for two 3-month trial subscriptions to FARM AND FIRESIDE. The two trial subscriptions must be new subscriptions. Remit in coin or stamps.

FARM AND FIRESIDE Springfield, Ohio

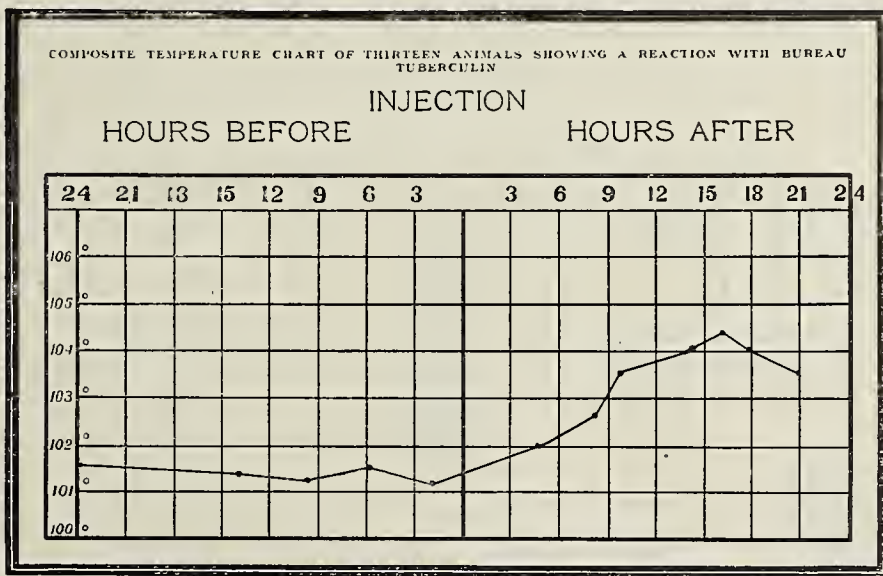

The Course of the Irregular Line Shows the Typical Rise of Temperature in Tuberculous Animals Under Test

of twenty-nine head of cattle, there has been a change from highly tuberculous herds into healthy ones by the method just outlined. The number of reacting animals at the beginning was one thousand and forty-five, and healthy animals seven hundred and eighty. When the work was finished there were one thousand eight hundred and ninety-six healthy animals and no reactors. The testimony of the men who carried out this work indicates that it entails a great deal of attention, but a trifling expense.

As stated before, this method depends so largely on the use of the tuberculin test that a few words must be said about that, also. Tuberculin was discovered by Professor Koch through a series of very in-

teresting experiments. It is made from cultures of the tubercle bacillus, which are grown on bouillon, containing an average of five per cent. of glycerin. An extract of the germs is made in the glycerinated bouillon on which they have grown, by heating. After the heating process, which requires from five to six hours, the germs are entirely removed by filtration through porcelain or earthenware. The liquid is then concentrated to one tenth of its original volume, and this constitutes the original tuberculin of Koch. For use it is diluted with a one half of one per cent. carbolic-acid solution, the usual dose being about one third of a cubic centimeter of the original concentrated tuberculin, or, in other words, about five drops. The tuberculin is injected under the skin of the suspected animal, and if tuberculosis is present, it is indicated by a rise of the temperature which begins about eight to ten hours after the injection, rising steadily to the maximum and falling gradually, the animal reaching its normal temperature as a rule within twenty-four hours after the injection.

WESTERN CANADA

What J. J. Hill, the Great Railroad Magnate, Says About Its Wheat-Producing Power

The greatest need of this country (United States) in another generation or two will be the providing of homes for its people and producing sufficient for them. The days of our prominence as a wheat exporting country are gone. Canada is to be the great wheat country." J. J. HILL.

This great railroad magnate is taking advantage of the situation by extensive railway building to the wheat fields of Western Canada. Upwards of

125 Million Bushels of Wheat were harvested in 1909, and the average of the three provinces of Alberta, Saskatchewan and Manitoba will be upwards of 28 bu. per acre. Free homesteads of 160 acres, and adjoining pre-emption of 160 acres (at \$8 per acre), are to be had in the choicest districts.

Schools, convenient, climate excellent, soil the very best, railways close at hand, building lumber cheap, fuel easy to get and reasonable in price, water easily procured, mixed farming a success. Write as to best place for settlement. Settlers' low railway rates, descriptive illustrated "Last Best West" to Superintendent of Immigration, Ottawa, Canada, or to the Canadian Government Agent. (8) H. M. Williams, 413 Gardner Bldg., Toledo, O.; J. C. Dun-an, Room 30, Syracuse Savings Bank Bldg., Syracuse, N. Y.

SOUTHERN FACTS REAL ESTATE OFFERINGS INVESTMENT OPPORTUNITIES

Answers furnished on all definite questions regarding

- Alabama
- Arkansas
- Florida
- Georgia
- Kentucky
- Louisiana
- Maryland
- Mississippi
- Missouri
- North Carolina
- Oklahoma
- South Carolina
- Tennessee
- Texas
- Virginia
- West Virginia

What state are you interested in? What do you want to know?

Southern Commercial Congress
Dept. F Washington, D. C.

GARDENER'S FRIEND

Handy Cultivator and Weeder
Saves two-thirds of your garden work! One man can do work of three. Boy can do two men's work. It draws—no chopping, back-straining hoe work. Thirty inches of cutting edge—five times that of a hoe.
Adjustable and reversible—will make planting rows and cover them. Has shield to protect young plants. Only one-sixth the price of wheel hoe, yet works in loose, sandy, uneven and littered ground where wheel hoe fails. Every one absolutely guaranteed. Only \$1.50. We pay express. Try one and be convinced. Thousands have done so. Write at once. Also ask for free book and testimonials.

A Snap for Agents Liberal terms to agents if you start at once. Chance to make big money. One man made \$18.50 in one day. Article sells itself. Use sample. We need to lay in big stock. Write today for particulars. This offer limited.
ULRICH MFG. CO., 133 River St., ROCK FALLS, ILL.

SPRAY FRUITS AND FIELD CROPS
and do whitewashing in most effective, economical, rapid way. Satisfaction guaranteed if you use BROWN'S
HAND OR POWER Auto-Sprays
No. 1, shown here, is fitted with Auto-Pop Nozzle—does work of 3 ordinary sprayers. Endorsed by Experiment Stations and 300,000 others. 40 styles, sizes and prices in our FREE BOOK—also valuable spraying guide. Write postal now.
THE E. C. BROWN COMPANY
15 Jay St., Rochester, N. Y.

Binder Twine 7/8 lb.
Fully guaranteed. Farmer Agents wanted. For samples and catalogue write
THEO. BURT & SONS, MELROSE, OHIO

Gardening---By T. Greiner

Through Failures to Success

A READER in Rhode Island writes: "I have a small garden which would scarcely grow anything but dock and the like when I took possession a few years ago. The soil is sandy loam with yellow clay bottom. The land slopes to the south and dries out quickly in hot weather. For several years I have made a compost of grass-cuttings, corn-stalks, etc., with house drainage and have put on some stable manure. I discovered some of the merits of dry farming before I read anything of that method, and now propose trying it more fully, as moisture is my greatest need in dry seasons. . . . After many failures I have been successful in raising cabbage, beets, corn, squashes, lettuce, etc. Potatoes have not done well.

"I have tried a number of years to raise string beans, but with poor success. The worms, I think, destroy the seed or the sprouts before they come up, and those that do get above ground make very little growth and bear but little. . . . How can I raise beans?"

I would suggest that you try the virtues of lime or wood-ashes. Your soil may be sour. Sweeten it by such means, and beans and many other shy crops will grow. The best way to make soil retentive of moisture is to fill it with humus. You might seed part of the land to clover. Lime applications will help the clover. Then after a year or two plow the clover sod under and seed down the other part. It is a good way to make the land clean and productive.

What is Witloof?

Witloof is now found in the Buffalo (and probably other cities) markets about as freely as asparagus. It is the blanched shoot or compact leaf stalks of chicory. I grew these shoots in a box-like place under a greenhouse bench during winter and early spring a year ago, and we greatly enjoyed it as a substitute for asparagus. Properly cooked it makes a delicious dish. It can also be grown in open ground for fall and early winter use, in which case it is earthed up for blanching like celery. And why not grow it thus? It gives variation in the bill of fare, and a wholesome dish. Try a packet of seed, and sow it like carrots, making calculation, however, for sufficient space in latter part of the season for earthing up. Every large seed-house offers chicory-seed, at five cents a packet.

Free Seeds and Packet Post

I have written to our member of the House of Representatives thanking him for the several packets of seeds which he sent to me from Washington, but calling his attention to the fact that I am very particular in selecting the varieties I plant and always purchase my seeds

and pay for them; that he, however, might be of real service to me and to other farmers if he would work for the establishment of a packet post so that we could have our seeds and other necessary equipments sent to us from seed-houses, manufacturers, etc., without having to pay an excessive tribute to express companies, and he really did promise to lend his influence in that direction.

Onions Rotting at the Root

A Virginia reader asks why his onions rot. They commence to rot at the roots before they ripen, and the trouble progresses from then until winter. "You may tell me it is the onion-maggot," he says. "I never find a worm about the roots. They are the potato onions."

I can't imagine what should cause an onion to rot from the root except it be the maggot, grubs or worms. You can settle that question by throwing out a spadeful of soil, and examining the soil coming up with the onions. If you don't find any maggot, grub or worm then, the cause must be a disease. Forward some affected specimens to your experiment station (Blacksburg, Virginia) for investigation and information.

Yellow Clay Loam for Lawn

"Will yellow clay, if enriched, make good top soil for lawn? I shall have some in grading." That is another of the questions asked. You can use almost any kind of subsoil to fill up, and if a little old compost or fine garden loam is put on top, grass-seed will grow in it. Exposure to the weather and manipulation, stirring, cultivating, etc., will in time fit any soil for plant growth. Lime applications are often very helpful, too.

A New Asparagus Culture

I wonder if any one ever thought of planting asparagus in hills to be cultivated both ways, and if not, why not? I am going to try it as soon as I have the chance. Four feet apart each way would be about right. If the land is made very rich to start with, and the plants set deep, and thorough cultivation given right along, the soil thrown somewhat to the hills during the cutting season, fine fat stalks ought to be the result, with moderate effort and expense.

The Early Peas

The early peas planted about April 1st are coming on fine. Pity I did not plant a lot of the later wrinkled sorts at the same time. We may not have another chance to work the soil, and plant seeds, for many weeks. The frequent and abundant rains keep the soil water-soaked right along at this writing. We have to expect such things in early spring, and make the most of our early chances.

Plants That Look Weak

The fact that a plant is smaller than another should not be accepted as proof that it be worthless. You can plant the cabbage or cauliflower or celery plant of smaller size with just as much confidence as the largest, thriftiest plant. In fact, I look with some suspicion on the overgrown plant, and especially the one that has large size on account of age. The smallest plants often give the biggest crops.

Sod for Potatoes

Fitting sod for potatoes is often quite a problem. If the sod is new, the task may be comparatively easy. You want a deep mellow seed-bed. New sod, if deeply plowed and well disked and pulverized, will give it. If the sod is old and tough, I would prefer to grow a crop of oats or corn to precede the potatoes. This will fit the land in the best and easiest way for the potatoes.

Arsenical Poisons

Professor Whetzel, of Cornell University, sends out another emphatic warning against the use of any arsenical poison (Paris green, arsenite of lime, etc.) except arsenate of lead in combination with the lime-sulphur mixture. Arsenate of lead has been found safe and effective. All the others are liable to injure the foliage. "We told you so." Now act accordingly.

The Carrots for the Table

Early Scarlet Horn is the carrot of my choice for earliest planting. I want some of these tender little carrots to go with green peas, or for creamed carrots, just as soon in July as they are big enough to use. Chantenay comes handy later, and gives us the bulk. A good cook can make a good, wholesome and palatable dish out of fresh carrots at any time.

Scarlet Runners to Eat.

THERE is one crop I think people ought to know more about—Scarlet Runner beans. They are the best beans grown for table use. We used to plant them in May in England, and keep picking till the frost cut them off. They are harder to grow in this country, the sun is too hot, and the bloom all runs off until about September, when the weather is getting cooler, they start again. So I made up my mind to plant them for second crop the first week in July, and I got about six pecks from one double row by the time the frost settled them. I cannot get brush conveniently—mine is a town garden—or I would grow more; as it is, I put two seven-foot posts, one each side of the garden with two wires at the bottom, and run strings from top to bottom, which they very soon climb up. People in this country think they are for flowers only, but once they taste them they want more. You pick, string and slice the pods and cook them just the same as bush beans. C. AKHURST.

Onions and Humus Economy

I CAN hardly refrain from a "chip in" to E. E. Allen's article on onions, which you printed March 25th. With us a yield of one thousand bushels per acre is an exception and not a common yield. After five years of experience we call a five-hundred-bushel crop quite satisfactory. In 1907 we produced one thousand and twelve bushels of Southport Yellows from nearly one and one half acres, or about seven hundred bushels per acre, and the bulbs were very thick and of good size; in fact, I see not how many more could be produced on a like amount of land. However, this was from the seed and not transplanted, as per Mr. Greiner's methods. We are located on good soil, in Wood County, Ohio.

I don't quite understand why E. E. A. does marking out with a horse when this way certainly leaves a great many horse-tracks to be drilled over and necessarily wastes a good many seed at two dollars per pound. Another thing, we cannot get a satisfactory stand of onions with less than four and a half or five pounds of seed per acre.

Would not that coat of hay and straw that is burned on the ground be far more valuable if plowed under and allowed to rot and become a part of the soil? Even granting that the weed-seeds would not be destroyed, still in these days of decreased fertility surely we cannot burn anything on the ground. R. E. ROGERS.

All Goods Guaranteed **Money Back on Demand**

THE BALTIMORE CO.
COOPERAGE Co.

No. 26 S. Liberty, Baltimore, Md.

Manufacturers—Tanks, Towers, Silos, Windmills, Pumps, Gasoline Engines, Motors and every kind of equipment for Supplying Water. Write us your wants to-day. Quick Shipments.

Arundel Silos



Of Southern Pine with our improved 1910 continuous door. 10 ft. by 20 ft., \$89.00, complete without roof. All other sizes equally as cheap.

"Simplex" System



This Pneumatic System of Water Supply 150 gals. daily capacity, complete ready to install, \$46.00. Anybody can do it with our directions. We also furnish this outfit for power up to 50,000 gals. capacity.

1000 Gal. Cedar Tank



20 ft. Steel Tower, complete like cut \$61.00. We make all other sizes.

100 Gal. Cypress Tank



Just the thing for the Farm. Can arrange for Spraying by adding Solid Cover for \$3.00 extra. Shipped whole ready for use. There is nothing cheap about our goods, except the Prices.

One Man Portable Sprayer

Price Complete, \$79.00



Spraying Tank, 100 Gal. Cap.



Complete like cut, \$11.40

Buy from the Maker and save dealer's profit—Get our circular, this ad. will not appear again

Fruit-Growing—By Samuel B. Green

Record Damage From Frost

NEARLY every year some sections of our fruit-growing districts are troubled with late frosts, but this year the injury is more complete than any year of which we have records. It seems incredible that on April 25th ice a quarter of an inch thick should be formed in the central Mississippi, and yet such is the fact.

In the wide section from which early strawberries are shipped in quantities there will be tremendous loss to the fruit-growers, who seemed just ready to gather the final returns for their labor. Apples, plums, peaches and cherries are destroyed over a wide area. It is certainly very unfortunate to have a spring start so early—to have the months of April and May reversed.

In looking over the effects of the freeze, I noticed that the plants naturally divide themselves into what we know as "frost-hardy" and "frost-tender" plants. The oaks and ash, for instance, have very tender foliage that was killed in the first freeze. The maples, elms, willows and poplars were scarcely injured by the first freeze, even in northern Iowa, Minnesota and Wisconsin, but the second freeze, which was accompanied by a high wind, was very hard on the foliage, because it was battered about while still frozen. It is not uncommon to have the shoots of asparagus frozen off in the spring, but it is extremely unusual in any of the Northern states to have pie-plant hurt. This was the case, however, over a large area in the northern Mississippi Valley. The currants and gooseberries are also seriously injured, and probably hopelessly destroyed, over a large area.

There never was a time when the general public was more interested in the effects of a late freeze than now. As a rule, any report that the fruit crop has been damaged by frost has been taken with a little salt and looked upon as an effort to boom prices; but this time it is generally realized as a calamity, in which all must bear a portion of the burden—the consumer as well as the producer; for there can be no question but that such a very general destruction of fruit and garden crops will mean a serious deprivation to hosts of consumers, and will materially increase the cost of living.

Holding Back the Blooms

This year's late frosts have brought to light many suggestions as to the way in which injury from them may be avoided. Among the most common is the statement that if trees are mulched, so as to hold the frost in the ground, they will be retarded in blooming and thus, perhaps, escape injury. In one of our daily papers a statement was made that a certain farmer hauled ice from the lake and put it around his apple-trees, and in this way retarded their blooming; in fact, he was far-sighted and felt that the warm weather was likely to produce just the disastrous results which have come to us. This matter attracted considerable attention, and a reporter for one of the daily papers asked what I thought of it. I said that such statements were common, but there was really nothing in them, so far as they applied to fruit-trees. The next morning I found my name in conspicuous black type, with the statement that I had denied that which had been asserted by an honest farmer and by a professor of physics in the high school. Nevertheless, I am sure I am right in this matter and that those who reported having had success in this way have been misled, and have probably mixed up the relation of cause and effect.

It is well known to all botanists that one portion of a tree may start into growth without regard to the other portion; for instance, in the old cold grape-tries of fifty years ago it was customary to plant the vines outside the grape-tries and bring them through the walls into the house, and frequently the roots would be frozen when the vines were started up inside, and the tops could be started into growth entirely independent of the roots. It is well known that the branches of plums, peaches and cherries may be brought into the house in winter and will flower independent of the root, thus showing that the portions of the plant start into growth according to the temperature with which they are surrounded, rather than the temperature which surrounds the roots.

Nurserymen in the Northern states, especially in Minnesota and the Dakotas, where the spring weather comes on quickly, occasionally find their trees in

nearly full leaf with the ground frozen, and they are unable to dig the trees.

I could cite many specific instances where the mulching of the trees to keep the frost in has been tried, but unsuccessfully. In the case, however, of strawberries, where we can cover the whole plant with straw, we may keep the plants back a considerable time. The same is true of raspberries; and even gooseberries may be covered with earth and retarded.

An Object-Lesson in Manuring

In showing graphically the effect of soil nitrogen on the growth of leaf crops, we use two flower-pots filled with rather inferior soil, into each of which we sow about a dozen spinach-seeds. These soon come up; then one pot is watered with a very weak solution of nitrate of soda. The result of this in eight weeks' time is very marked. The plants watered with nitrate of soda will show four or five times as much growth as those not watered, and the foliage will be dark green and extremely vigorous, while those not watered are small, inferior and often have yellowish foliage. The illustration shows the contrast.

It should be more generally known that the effect of nitrogen on crops is to cause an excessive growth of wood



The Difference That Nitrogen Makes

and foliage. This is desirable in the case of foliage crops, but not in the case of fruit-trees. Lettuce, spinach and similar crops are especially benefited by nitrate of soda; but the use of large quantities of readily available nitrogen fertilizers, in the case of nursery or orchard trees, stimulates a growth of wood that is very apt to be injured in severe winters, since it seldom ripens up well. On the other hand, the presence of large quantities of potash and phosphoric acid generally tend to encourage an early ripening of the wood, although the foliage often looks rather yellow if the supply of nitrogen is light. Where fruit-trees are making a reasonably good growth, it is not desirable to manure them; but where the growth is weak, then applications of stable manure or commercial fertilizers are desirable.

Norway Poplar in Dry Sections

J. L. B., Oasis, California—The Norway poplar thrives throughout about the same range as the cottonwood. As stated in a former issue of FARM AND FIRESIDE, it is a selected form of the broad-leaved cottonwood (*Populus deltoides*), and on this account is more resistant to disease than our ordinary cottonwood. I do not know how it would thrive in a semi-arid sage-brush country, but should not expect very much from it unless there is plenty of water in the soil that the roots of the tree can easily reach, since it needs a large amount of water. This tree closely resembles the Carolina poplar, so much so that some of our nurserymen claim it to be the same thing. Personally, I think it is somewhat different and a little faster grower. It grows readily from cuttings.

Caring for Girdled Trees

A Minnesota reader states that about three hundred of his trees have been girdled by mice, which seem to take the outer dark bark off and to leave an inner bark. The trees are eight years old and vigorous. If only the outer bark is taken off, speaking in a general way, and the inner bark eaten down to the wood in only a few places, leaving enough to make a connection across the wound, the tree can generally be saved, and probably the best treatment is to paint the wounds with grafting-wax, putting it on with a brush the same as paint. When this is done, wrap each tree in rosin-sized building-paper or similar paper that has no coal-tar in it; even several thicknesses of newspaper would answer very well if properly tied on.

Not Ants, But Aphides

R. C., Mishawaka, Indiana—You state that you have an orchard that is growing well and just commencing to bear fruit; that in the spring soon after the leaves come out, ants crawl on the trees, settle in the leaves, draw them together and stay in there, and in this way destroy the leaves and fruit. I am inclined to think the trouble with your trees is an infestation with a minute leaf-aphis, which is a little green insect commonly called plant-louse. If you look carefully, I think you will find them in the leaves that are curled up. The ants do not eat the foliage and would not go onto the trees were it not for these insects. The aphides produce a sweetish fluid, of which the ants are fond, and hence their presence on the trees. The best treatment is to use tobacco-water made from raw tobacco. In making this, pour hot water on tobacco-stems or tobacco-leaves until the liquid is about the color of strong tea, and use as soon as cool. Place in a shallow basin, and gather the tips of the branches together and dip into it. This insect seldom attacks old trees, but is most abundant on young thrifty trees, and in such cases the branches are easily pulled down and dipped.

To Save the Grapes

Mrs. M. O., Nevada City, California—You state that your Pink Tokay grape-vines lose their leaves when the grapes have almost grown and that the grapes wither on the vines before they are ripened. This trouble is undoubtedly due to some fungous disease, probably the well-known downy mildew (*Peronospora viticola*), and the remedy is to spray with Bordeaux mixture. This should begin early in the spring, and the first application should be made before the leaves appear, thoroughly drenching the vines with it. It should be repeated as soon as the fruit is set and at intervals of about two weeks until the grapes begin to color, when I think no further application will be necessary. The recipe for Bordeaux mixture and the best method of applying it have been given in these columns; but if you do not have it at hand, you can obtain full information by addressing the Experiment Station, Berkeley, California.

1000 PIECES OR ONE?

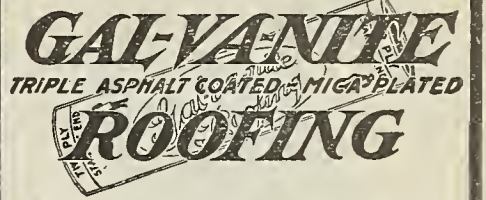

Makes a One-Piece Roof

No poor shingles to wear out, no cracks to leak.

Instead of patching the old shingle roof every year you'll forget you own a roof.

Gal-Va-Nite, when properly laid, is perfectly flat and stays that way; it does not become shabby looking by the appearance of wrinkles or creases.

It is mica plated on both sides, keeps all the weather out, and its own life inside. It is honest all the way through in fact; that's the reason you'll like it.

Write us for free samples, and booklet about good roofing.

Union Roofing & Mfg. Co.

Main Offices and Factory 1141 to 1157 E. 7th Street

St. Paul. Minnesota



Get our FREE Books and Get More Profit from Your Farm

The Business Farmer doesn't sell out and buy new lands. He makes his old lands new by fertilizing.

Get our Free Books which go into the whole subject of Nitrate of Soda fertilizing and show how little it costs to get larger crops and more profits.

Nitrate of Soda

is an investment that's bound to pay. Thousands have proved it. So can you.

HAY—Nitrate of Soda, used 100 lbs. to the acre has increased the yield of barn-cured Hay 1000 lbs.

CORN—Nitrate of Soda, used 100 lbs. to the acre, will increase the yield of corn 280 pounds of grain.

ALFALFA—Nitrate of Soda is also highly successful in starting Alfalfa right.

Special directions and books on the crops you are interested in—free of charge and postpaid.

Send a post card for your book or books Today

Dr. Wm. S. Myers, Director Nitrate Propaganda
John St. and 71 Nassau St., New York

It is to your advantage to mention Farm and Fireside in writing to advertisers. Farm and Fireside folks get the very best attention.



Irrigated Farm and Fruit Lands

The small irrigated farm or orchard means greater production with less labor. It takes away the element of chance and makes a good crop a reasonable certainty. The land in the Northwest such as is being irrigated by government and private projects in Montana, Idaho, Washington and Oregon, on or reached by the Northern Pacific Railway, is exceedingly rich and requires only moisture to yield bountifully. This moisture is provided by irrigation, which makes irrigated farming, fruit and vegetable raising a scientific profession, not a drudgery. The ideal climate is a strong argument in favor of the Northwest.

If you want to know more about the possibilities of making your efforts bring you greater returns, write for information about these irrigated lands. Maybe the "dry-farming" territory will interest you. Write tonight and state what section you are most interested in. Don't delay. The information will cost you nothing and will pay you well.

The Scenic Highway Through the Land of Fortune Northern Pacific Railway

L. J. Bricker, General Immigration Agent
Dept. 206, St. Paul, Minn.

A. M. CLELAND, General Passenger Agent, ST. PAUL



Practical Poultry-Raising



Get Rid of Germs Prevent Infection and Disease

By using a perfectly sure and safe germicide and disinfectant. Disease breeds in all places where filth or germs may accumulate, as a preventive, stables, all animal pens, bird cages, closet bowls, sinks, slop jars, garbage cans, should be sprayed with

Germa The Germ Destroyer

Germa is a powerful disinfectant, concentrated in form and convenient to use. When added to water it forms an emulsion which will quickly kill any germ or insect with which it comes in contact.

It is sure death to chicken lice—protects farm stock from flies, insects and disease germs.

Sprayed on trees and vines it stops fungus growth—quickly killing insect pests of every kind. It will rid the house of flies, cockroaches, ants, bed-bugs, moths. You will find Germa useful in a score of ways, in home, on farms and in nurseries.

Try Germa Free

I want you to test Germa at my expense. Simply fill out the coupon below and mail to me. I will immediately mail you a sample can of Germa without expense or obligation to you. With the sample can you will receive full directions for getting rid of every kind of germ or insect pest.

H. F. BUSH, Gen'l Mgr.
Rural Home Chemical Co.,
Wellsboro, Pa.

Fill Out and Mail This Coupon Today

H. F. BUSH, Gen'l Mgr., Wellsboro, Pa. [209]

Dear Sir:—Please send me free of all expense, a sample can of Germa—the Giant Killer, which I agree to use according to directions.

Name

Address

Town State

I trade with

Imaginative Poultry-Raising

A BUSINESS man living in an Eastern city writes thuswise: "Among the papers that come to the office is FARM AND FIRESIDE. A couple of years ago I read a warm article of yours about parcels post and ever since that time have been considerably interested in what you have to say about things generally. For some time I have been slightly touched with the poultry-raising fever. Wife, who is also affected, has frequently called my attention to large advertisements of two books, one entitled 'The Philo System' and the other the 'Corning Egg Book.' She ordered both and we read them, then she sent them to a sister, who lives on a farm in Iowa, for her opinion. This lady wrote 'Impractical' across the title page of one and 'Nonsense' on the other. Now, I come to you with two questions: First, what do you think of those books? Is it possible for a man to go upon a small farm of ten or fifteen acres and, by giving his entire time to the business, make a living, say two thousand dollars a year, producing eggs for market?"

To the first question I have no reply. To the second I will say, "No."

The kind of business done by the parties mentioned in the Corning egg book could not be done by one poultry-raiser in twenty-five thousand. They sell their eggs at an average of forty-nine cents a dozen. Then they sell pullets for breeders for two dollars apiece, broilers at thirty cents apiece and the poultry manure for about two hundred and fifty dollars a year. Do you know of any one doing that kind of business? One of the most intensely interesting books I know of is one that tells how five miners opened up a new mine in Colorado and made something over a million dollars apiece in less than two years. As a story, it was a very interesting book. As a book of instruction it was not worth a rap. The Corning egg book belongs to the same class.

I have been "through the mill" and know positively that it is next to an impossibility for any person without several years of experience to take up the egg-producing business and make half a living at it. And if he has the experience, he would have to be very favorably located and have every advantage to make a living. The children tell each other that where a rainbow touches the earth there is a pot of gold. People who read such poultry novelettes as the books mentioned are very apt to acquire the idea that there is a wad of cash not just where they happen to live, but away off in some locality they actually know nothing about, just waiting for them to pick it up and put it in their pockets. There are very few spots in the United States where eggs can be sold the year around for forty-nine cents a dozen and I know good breeders who have found it quite difficult to sell a hundred breeding pullets for two dollars apiece. And advertising cut quite a slice out of the profits on those they did sell.

But, as I have often said, there is money in the poultry business when it is well managed. Few people qualify themselves for successful poultry-raisers. They will not give it the close study and attention necessary for success. For this reason I do not advocate it as an exclusive business for any one who is not especially favorably located. And then it is far better to combine the production of market poultry with eggs than to attempt either one exclusively. That gives one two strings to his bow.

As a side line to almost any other vocation, where one has some spare time, as he does if he is an eight-hour-a-day man, I know of nothing that will give more satisfaction and profit. Giving a flock of poultry the attention necessary to make it profitable is vastly more conducive to health and good citizenship than loafing about town or playing games in some hall. Very little ground is required for two dozen hens and in

return for good care they will yield a big lot of food in the way of eggs and young chicken meat. One man I know has kept twenty fowls in his back lot eight years and he now says he could not keep house without them. He raises ten pullets each year to replace the ten two-year hens that are killed for the table or sold when they cease laying in summer to molt. He is never without eggs and he raises about fifty chickens a year for meat. He says one can scarcely imagine how much those few fowls contribute to the table in a year.

As a side line for the farmer's wife, poultry-raising is, when properly managed, the most profitable occupation I know of. The principal trouble with it has been make-shift tools and poor management. I do not by any means advocate the purchase of an expensive outfit for raising poultry on the farm, but I do advocate the use of the best home-made tools.

There are some good ideas in all these much-advertised Egg books and System books and Secrets books, but they require the sifting of an experienced poultryman to get them out.

FRED GRUNDY.

Poultry Common Sense

How many times have I been asked what is the best breed of fowls? The fact is that one breed will do about as well as another if given the right care.

I have bred poultry ever since I was eight years old and have learned many things in the bitter school of experience, which, though it is a pretty expensive school, certainly gives one knowledge that no college can give. I have learned that it is not the breed that counts, but the strain. Here is where so many fail. They select a breed they like and the birds do not lay well; they discard it and select another. Some strains of Plymouth Rocks are bred for layers, some are not. So it is with every breed. After learning this, I went to work and picked the best layers, until now I can take any breed and in a few years build up a laying strain.

Others fail because they put about all their capital into poultry-houses. Hens are blind to fancy peaks, and so on. All they want is good comfortable quarters and they will do the rest.

Comfort means good ventilation for one thing. When one enters the average poultry-house in the morning, the odor is very bad. Now that helps along the roup, which is the forerunner of all sickness. I removed a window, covered it with one-inch-mesh wire and then with cheap cheese-cloth. The air enters through the cloth, yet there is no draft, and now I have hardly a cold among my flock.

But when one gets a cold, I don't wait until it runs into roup. Each night when locking up I go into each pen and listen. If any bird breathes heavily, I simply give it a one-grain quinine capsule.

Too many farmers and poultry-raisers are prone to feed whatever they raise most. That is entirely wrong; the hen needs a balanced ration just as the cow does. A number of rations are recommended, but I have found the best one to be one I make myself, with equal parts of wheat, oats or barley for morning feed; at noon a light feed of small grains, such as cracked corn, millet, peas or Kafir-corn, and at night a mixture of buckwheat, oats and corn. You notice I advocate a good deal of oats; they have bulk and there is something in oats that gives speed to the mare and gives material for eggs to the chicken. Bran, charcoal, grit and oyster-shell is constantly kept before the birds. Once a week a mash is fed; it can be made up of equal parts of bran, middlings and corn-meal, a little cut clover, and a pinch of salt and a bit of red pepper for seasoning.

Give the hen good feed, clean water, a dust bath and clean, airy, warm quarters, and the egg-supply is certain.

DONALD BOYCE.

Cheap Colony Coops

GET some large dry-goods or shoe boxes about four feet long by three feet square and after removing the cover, lay on side with opening to the south. Cover the three sides and top with roofing-paper to make them draft-proof. Then take the boards of the cover and by fastening them together with cleats make two doors, one upper and one lower. Hang these by the top with strong hinges, to swing outward. You will need a strip of two-inch stuff across the middle of the front to fasten the lower door on. This also holds the wire screen which covers the upper opening.

By having the doors in two sections you can close the chicks in with the lower door, leaving the upper one open for ventilation, and still be secured against night prowlers by the wire screen.

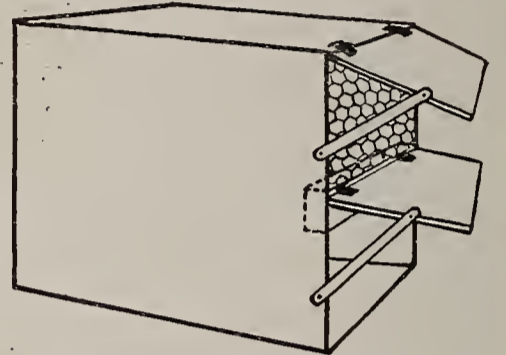

Coop With Doors Propped Open

Boxes which will answer this purpose can be purchased for from twenty-five to seventy-five cents each and, counting the cost of labor, roofing-paper, wire, extra lumber, hinges, etc., the entire cost would not go much over one dollar per coop. Here I get the boxes for thirty-five cents each, which makes the cost of the coop complete about sixty cents.

I scatter these coops about the farm, under fruit-trees, etc., and as soon as the chicks are weaned from the heated brooders put them in these coops. Fifty can easily be kept in a coop until the cockerels are large enough to separate from the pullets, when the coop is given to the remaining pullets. The latter can remain in colony coops until transferred to winter quarters, which should be about the time the first laying begins. This gives them time to become accustomed to their new home before coming into laying and avoids checking them. Of course, it is supposed that these birds have had free range, or the number per coop must be greatly reduced.

The coops should be kept clean and whitewashed occasionally to guard against lice.

A. E. VANDERVORT.

Lime Light on Lice

SOME time ago I commenced to use air-slaked lime in my chicken-house. Since then there have been absolutely no lice in my roosting-room. I crush the lumps in the lime if there are any and use it liberally on the perches and dropping-boards. Once a week I run the fowls out and with a fire shovel stand in the door and give several sweeping throws into the house, which raises a cloud of dust that settles over everything—a dry whitewash, if you please.

Not long ago I was showing my poultry-house to a visitor and invited an inspection of the nest arrangement. "Ugh, not for me! I don't want chicken-lice on my neck." It was hard for him to believe that a hen-house could be free from lice.

Lime is effective; it is healthy and a deodorizer; it is easily applied; it is cheap. Its only disadvantage is that it is a little dusty, but we do not wear our Sunday clothes around the chicken-house much.

W. THAYER.

Capons as Foster-Mothers

IT is not generally known that capons make the best of mothers. Let the hen hatch the chickens, then take them away and put them in a coop with a capon. Keep them shut in for a couple of days. The capon will care for the chickens and brood them as tenderly as the old hen.

One advantage of the capon is his broad sympathies. Chickens from other broods are welcomed to his coop and are not picked to death as is common with a hen mother.

When the chickens are old enough to wean they can be taken away and newly-hatched chicks given to the capon. If one does not caponize their own chickens, it sometimes pays to buy several for rearing purposes.

ESTELLE M. PLACE.

"BRECO" Freight Prepaid

Rubber Roofing Don't think of using any kind of roofing till you test sample of old reliable Guaranteed "BRECO." Why pay more? Investigate, and you will order here today.

BOOK AND SAMPLE Free Book proves and shows testimonials of Breco Service. Waterproof and fire-resisting qualities. Cement and nails free. Write today.

The Breese Bros. Co. Roofing Dept. 24. Cincinnati, O.

BREEZE 7 Handsome Models \$275

Travel the worst roads with ease and comfort And Up SEND FOR CATALOG "U" The Breeze is strong, simple, speedy and safe. Best motor vehicle built for country roads—mud, deep sand or high hills. 13-18 H.P. engines. Lowest cost of upkeep, least tire trouble, Handsomely finished. THE JEWELCARRIAGE CO. CINCINNATI, OHIO

PATENTS Secured and SOLD or our fee returned

Five practical, useful booklets concerning the obtaining, financing and selling of patents, Sent Free. Write Today. Advice and searches Free. Dept. T. PATENT DEVELOPMENT CORPORATION, Washington, D. C.

PATENTS WORTH FORTUNES

Inventors: Send 6 cts. for our Valuable Patent Books B. S. & A. B. Lacey, Dept. 49, Washington, D. C. Est. 1869

PATENT YOUR IDEAS. They may bring you wealth.

Free report as to patentability. Illustrated Guide Book, and List of Inventions Wanted, sent free. VICTOR J. EVANS & CO., WASHINGTON, D. C.

Get My Big Split-Hickory Book, Sure This Year — Shows 125 Styles — FREE

Let Me Pay the Postage—Just Send Your Name

I START right out to show you saving, direct prices, and over 125 styles of Famous Split-Hickory 1910 Vehicles and high-grade harness, by spending 8 cents postage to mail you my splendid 1910 Big, Free, color-illustrated Book of Styles. Select what you want—choice of trimmings and finish, etc.—made-to-order. I ship promptly on

30 Days' Free Road Test I can afford to do this because I know you'll be pleased because my vehicles and harness are made right—because I save you big money on prices by taking only one small maker's profit—because my immense production

and large number of sales (over 150,000 huggles now) get the best grade of materials and work for you and save me on costs—you get my

2 Years' Guarantee backed by the largest exclusive vehicle and harness factory in the world. Write me today. H. C. Phelps, President.

The Ohio Carriage Mfg. Co. Sta. 27, Columbus, O.



H. C. PHELPS Manufacturer Split Hickory Vehicles

SAVE 25% AND UP ON PRICES

Story of a Record-Breaking Cow—By Edgar L. Vincent

SOME one has said that the world will find its way to the home of the man who does something worth while, no matter if he hides himself in the heart of the deepest forest. Just now the eyes of all who are interested in fine stock and splendid farm achievements generally are turned toward the country place of a man who a few weeks ago never had been heard of very far outside his own quiet neighborhood, and who probably would have gone on in this narrow way as long as he lived, had it not been for a young cow.

Eugene La Munion, the man who has thus speedily found himself and his cow on the lips of men everywhere, lives three miles out of the little village of Solsville, Madison County, New York, and the cow that has brought his name into this repute is Lockhart De Kol, No. 101,544. The particular reason why Lockhart De Kol has riveted the attention of the dairy world upon herself is that she has just broken the world's record for the amount of milk given and butter produced therefrom by a two-year-old cow in a seven-day test. Up to the time of this performance the world's best figure for a cow of this age was 27.06 pounds of butter in seven days. This fine cow has beaten the record by 2.21 pounds, entitling her to the grand total of 29.27 pounds, taken from 556.9 pounds of milk.

Eight years ago Mr. La Munion went on a farm of one hundred and fourteen acres a little way out of Solsville. He had no great amount of capital and was compelled to begin where so many other men have begun in this country, at the very foot of the ladder. When he took the farm, he found only a small herd of commonplace cows. Prior to his coming a pure-bred sire had been used for some time, so that there were some grade Holstein cows in the herd, but none of these had distinguished themselves. A few of these grades are still in the stable, but Mr. La Munion is fast closing them out. There were many cows all about him which were fully as worthy as any the younger farmer had. The difference between him and his neighbors was that he was fired with an ambition to do better than any one about him.

In pursuit of this commendable object he bought two pure-bred heifer-calves, and the next year one more. From this foundation he has built up to the present enviable position he occupies. Of the ancestry of these heifer-calves, little is known beyond the fact that they came from stock which had at one time been registered, the owner having for some reason discontinued the practice. After that, as he was able, Mr. La Munion bought now and then a good registered calf, thus adding to his stock and still farther preparing the way for greater results.

When the two first calves reached the age of two years, he placed at the head of his herd a choice bull, and began registering his stock, joining the Holstein Friesian Association. Two years later he adopted the herd name of "Lockhart," giving that as a prefix to the name of each animal born.

September 5, 1904, Mr. La Munion had in his yards one of the best sires ever known in the neighborhood, Prince Hengerveld De Kol Kuperus, 38,868, son of Plum Hengerveld De Kol, himself an excellent animal. This was the father of the cow which has lately distinguished herself so signally. The mother of Lockhart De Kol was Lyndia Lockhart Heegstra, 2d, 83,093. Mr. La Munion states that her grandmother was a heavy milker, having given, as he has been informed and believes, seventy-five pounds of milk in a single day although the record was not official. Lyndia Lockhart Heegstra, 2d, gave on a seven-day test 588.9 of milk, yielding 21.88 pounds of butter. She has a sister that has also won a very enviable place on the herd books of the Holstein Friesian Association.

February 25, 1907, the heifer-calf, "Lockhart De Kol," was dropped of these parents. At the age of two years and one day she began giving milk herself, making on a seven-day test, when she had been giving milk about thirty days, 335.5 pounds of milk, from which were taken

13,907 pounds of butter. Her second calf was dropped when the mother was two years, eleven months and twenty-one days old, or on February 16, 1910, making her at the time a little less than three years of age. The test by which she established her record was completed along toward the latter part of March, 1910, having lasted thirty days. From the best seven days of this period the world record was taken, seven consecutive days, of course, being selected.

The Methods That Won Success

No study can be of greater profit than to inquire briefly into the methods of care and feeding by which it has been possible for Mr. La Munion to bring his herd up



The Cow That Did It

to its present enviable place. He has one hundred and fourteen acres of rolling land, with soil fairly fertile and adapted to the growing of grass, corn and particularly alfalfa, although this last is really only in its infancy with him. A spring near the barn furnishes water constantly for the stables.

The barn is furnished with cement floors in the stables, and water is brought in to basins, one between every two cows. A pair of scales hanging in the stable indicates one secret of this farmer's success. To know what any herd is doing, an account must be kept with every cow and this account placed in a lasting record form.

To come to the case of the cow, Lockhart De Kol, Mr. La Munion states that he took the calf away from the mother at once after its birth and began feeding it new milk. This is his plan with all calves. All his stock are dehorned by the use of caustic potash. If this is done before the calves are three days of age, he states, there is little pain and little doubt of successful operation.

The record-breaking calf was fed only



The Mother of the Record Cow

new, warm milk for about eight weeks. Then gradually skim-milk was given instead and some grain added to the ration, usually wheat-bran, the brawn and muscle making properties of which are not surpassed by any similar food. This was given twice a day, and dry, never in the milk. The next season the heifer ran with other cows in the pasture, receiving no care beyond that usually given the herd. "It was born in her," he says of the cow's achievements afterward. "I did not feed it into her. It was there."

The use of good warm milk as a food for young calves is fully attested by the growth and appearance of some calves Mr. La Munion now has. I saw two beautiful bull-calves that have come up to the age of four months, never having had anything except new warm milk to eat. This early start counts for much.

Prior to the time of taking the test,

Mr. La Munion states that he had been feeding Lockhart De Kol just as he did the rest of the cows. That is, he had been studying them all and noting what each liked to eat best and giving each a ration accordingly. This he believes to be the real secret of successful feeding. These are practically his words:

"We don't feed land all the same way. We try to find out what any piece of land needs and then give it that fertilizer it seems to need. If another man should take his cows and feed them all as I have this one, he probably would not hit it at all. I have not fed mine all alike. If I should do that, they would not do their best. I just stayed with my cows and tried to find out what they did the best on and then gave it to them. It is all in the man."

When Mr. La Munion determined to call for an official inspection of his herd, he sent to Cornell University and asked that a man be assigned to assist him. "The man who came I never saw before," he says. "If I had asked for any particular man, I would not have got him! They sent me R. R. Page and he stayed ten days. At the end of that time Mr. R. Vrooman came. He was followed by Frank Davis, and he remained till the end of the thirty days."

As to the plan of feeding during this test Mr. La Munion continues:

"I fed four pounds of test feed, made up of bran, gluten, 'Ajax,' oil-meal, oats and hominy. Then I also gave eight to ten pounds of light feed, containing bran, hominy and oil-meal. This I fed four times a day, dividing it up fairly. Besides this the cow had what hay she would eat and from five to seven pounds of good ensilage. Water was all the time before her. We did not give her a drop of medicine. She was not off her feed once during the whole time."

"When Mr. Vrooman came, he and Mr. Page made a one-day retest. One of them stayed in the stable with the cow all the time, each staying six hours. This was to show that everything was done fair and square. No strangers were allowed to come in, for that would make the cow nervous and act against the test. We milked her four times a day."

Mother and Daughter

Lockhart De Kol is a fine-looking cow, as the accompanying picture proves. Her markings are good, the teats and udder well developed. Some objection might be made to the markings on the face, there being two splashes of white on the forehead and one running from the mouth upward part way across the nose.

These objections, however, vanish in the presence of a record such as she has made and the great promise she gives for future work.

The mother of this young cow is also a noble animal, showing an udder of mammoth proportions and having a face that is of surpassing beauty. This cow, Lyndia Lockhart Heegstra, 2d, has heretofore been favored by Mr. La Munion by having her story told on the letter-heads sent out from "Lockhart Holstein Farm."

At the head of his herd Mr. La Munion has at present the sire, Sir Lilith Hengerveld, No. 55,436, a fine two-year-old. The record-breaking cow has, however, been recently bred to Sigis Fayne Hengerveld, of Syracuse, by King Fayne Sigis, by Moyer's King Sigis, dam Grace Fayne 2d Homestead.

Some unauthorized statements have been made as to the offers Mr. La Munion has had for Lockhart De Kol. Let it simply be said here that while no one is authorized to place a figure on her except the owner himself, he naturally values her very highly and will not part with her for any small consideration. He is, of course, elated over the success which is at last coming to him in return for his long and well directed efforts, but he is not the man to lose his head. He is planning for still higher things, as may be seen by the fact that he has just bred Lockhart De Kol to one of the very best sires within his reach, and this at very great expense, it being necessary to take the cow across the country by rail and by trolley.

Mr. La Munion gives the farmers of

[CONCLUDED ON PAGE 11]

A Fifteen Minute Course in Paint Economy



THE first lesson in paint economy is to use pure white lead, guaranteed by the "Dutch Boy Painter" trade mark, with pure linseed oil, in all painting, exterior and interior.

¶ The second and third lessons and several more, but all short and easily learned, are contained in the collection of booklets which we call "Dutch Boy Paint Adviser No. 47." Ask for this adviser. It is free and will help any property-owner to become paint-wise. To be paint-wise is no trivial thing. It is mighty easy to waste money in paint; either by not using it at all, or, nearly as bad, by using poor paint. Be paint-wise.

¶ Write for "Dutch Boy Paint Adviser No. 47" today. Free.

Our Pure White Lead ("Dutch Boy Painter" trademark) is now packed in steel kegs, dark gun-metal finish, instead of in oak kegs as heretofore.

National Lead Company

An office in each of the following cities:

New York Boston Buffalo Cincinnati Chicago
Cleveland St. Louis
(John T. Lewis & Bros. Co., Philadelphia)
(National Lead and Oil Company, Pittsburgh)

United States Cream Separators

Save \$12 to \$20 per Cow EVERY YEAR OF USE

Over all Gravity Setting Systems

And \$5.00 to \$7.50 per Cow

Over all other Separators

Holds World's skimming Record Won Grand Prize, Seattle, 1909

Write for Catalog 69—It clearly explains everything.

VERMONT FARM MACHINE CO., Bellows Falls, Vt.

From Shafts to Pole in a Jiffy!

Fernald Quick-Shift makes change from pole to shafts or shafts to pole almost instantly. Fits any vehicle. Labor saver. Simplest device made. To connect, throw lever up; to release, pull down. No tools, no special shaft or pole irons. A positive anti-rattler and can't work loose—takes up its own wear. Spring of best oil-tempered steel. Best dealers everywhere. Also supplied by up-to-date buggy manufacturers with their vehicles. Ask your hardware or harness dealer or write us.

FERALD MFG. COMPANY, North East, Pa.

Fernald Quick-Shift

\$15.95 AND UPWARD AMERICAN SEPARATOR

THIS OFFER IS NO CATCH.

It is a solid proposition to send, on trial, fully guaranteed, a new, well made, easy running separator for \$15.95. Skims hot or cold milk; making heavy or light cream. Designed especially for small dairies, hotels and private families, different from this picture which illustrates our large capacity machines. The bowl is a sanitary marvel, easily cleaned. Gears thoroughly protected. Write ten orders filled from Western points. Whether your dairy is large or small write us and obtain our handsome free catalog. Address:

AMERICAN SEPARATOR CO. BAINBRIDGE, N. Y.

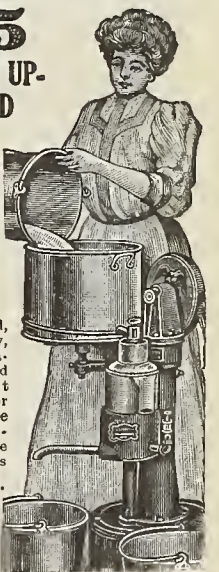

Another Slap



Another farmer takes a slap at disk filled cream separators. Prefers a modern separator—one without contraptions. Now owns The World's Best, a

Sharples Dairy Tubular Cream Separator

"South Lyon, Mich., March 10, 1910. The Tubular is giving great satisfaction. Before buying the Tubular we had on trial two disk separators. Took about three times as long to wash them as to wash the Tubular. Would not take five times what we paid for the Tubular if we could not get another. Consider the difference in easy washing, alone, a whole lot. Disks are the meanest things to clean we ever attempted to wash. Made a test of the skim milk and found Tubular skimmed closest—also had best method of oiling and saving oil.



Tubular sales exceed most, if not all, others combined. Probably replace more common separators than any one maker of such machines sells. World's biggest separator factory. Write for catalogue No. 112

Only piece inside Dairy Tubular bowl.

THE SHARPLES SEPARATOR CO.,
WEST CHESTER, PA.
Chicago, Ill. San Francisco, Cal. Portland, Ore.
Toronto, Can. Winnipeg, Can.

Live Stock and Dairy

Cross-Breds vs. Pure-Breds

EVERY one engaged in general farming ought to be interested in the production of pork, on account of the high prices prevailing. There is every probability of these figures being maintained for some time. The number of hogs now in the hands of the farmers is said to be much smaller than eighteen months ago, many having been tempted to sell off their stock hogs.

One of the first questions asked by the farmer going heavily into hog-raising is: "Shall it be cross-breds or pure-breds?" A great deal has been said by the agricultural press against the crossing of breeds. For some years the writer raised cross-breds and for many years raised registered Berkshires, so he claims to be in a position to compare relative results.

If you go into the business of raising pure-bred hogs in these days of competition, you must get stock with long and noted pedigrees, and with a certain conformation of body and color markings; these cost a great deal more than the average farmer can afford to pay. But the buying and raising is the easiest part; the tug of war comes when you offer your hogs for sale. You have to spend a large amount in advertising and keep everlastingly at it until you get up a reputation, when you can cut the "ad." ac-

count to some extent. Most buyers don't come to your farm to see your stock, but write, asking description, etc., and end by requesting that you ship the hogs to them "on approval." If the animal strikes their fancy, they keep him; if not, they send the hog back at the owner's expense.

Now, take the other side of the case. In buying pure-bred hogs to cross it is only necessary to get large young sows, not too ragged in conformation, but with no requirements as to points. They must, however, be pure-bred. These can be bought for less than half price from almost any reputable breeder, as there are always pigs in every litter whose only defect is markings. The same rule applies to the boar. Be careful to see that he is not related to any of the sows.

It has been my experience that if you mate a Berkshire boar to a Poland-China sow or any of the pure-bred sows the pigs of this union grow faster and are much larger when six months old than pigs the same age by parents of the same breed. But if the cross is repeated the same results do not follow; it seems the offspring of cross-breds commence to degenerate. As a general rule a sow will produce thrifty pigs until she is eight years old and the male will retain his vigor equally long. When your sows are six years old, serve to some pedigreed boar of the same breed and keep the best of the pigs to replenish your stock when their old age compels you to sell your sows to the butcher.

I made more money on my registered Berkshires than on my cross-breds, because I could only get three and a half cents per pound gross for the latter. If I could have gotten the prices now ruling for pork, the cross-breds would have come out ahead. Where any one has plots sown in alfalfa, rape and cow-peas, respectively, grazing them in the order named and then turning the hogs into the sweet-potato patch—which ought to be large enough to feed the hogs two months—the cost of raising pork to-day won't exceed more than four cents per pound gross, under our Virginia conditions. Of course, you have to feed a little corn all the time and a good deal in finishing off.

Altogether I think it much more satisfactory to raise hogs to sell as pork than to sell as breeding stock, because you always have a good pork market at your command.

An Account With a Cow

IN ONE of your recent issues you asked for experiences with the testing of cows. I have had only one cow for a few years past, but have known she was a good one. About December 20, 1908, she dropped a calf and I began a careful account of her product for the year, which I find as follows:

Calf sold.....	\$.75
Milk sold, 748 quarts at 6 cents a quart	44.88
Milk used, 365 quarts at 6 cents a quart	21.90
Buttermilk sold	3.08
Butter made, 392 pounds at 30 cents a pound	117.60
Dutch cheese sold	35.90
Dutch cheese used (low estimate)	10.20
Total	\$234.31

COST OF KEEPING

Hay, 2½ tons (estimated), \$17.00 per ton	\$42.50
Grain (nearly)	24.00
Pasture	7.00
Total	\$73.50

My feed of grain throughout the year was a heaping two-quart dish of bran and half a pint of cotton-seed meal, mixed with cold water in summer and hot in winter.

The cow had also some Japan millet in the latter part of the summer, sweet apples during the fall and perhaps five bushels of carrots. I think the extra feed might bring the cost of keeping up to eighty dollars, leaving a balance of one hundred and fifty-four dollars and thirty-one cents.

Unless the separator is taken apart and scalded after every using, your butter will not be as good as it would be by the old-fashioned pan-and-skimmer method. Running water through it will not do. Take it apart and scald it.

Clean-looking water may have typhoid germs in it. If it comes from the neighborhood of the privy, it is likely to be deadlier than most poisons. Washing your milk containers with such water is sure to spread the dreadful disease.

Spavin Cured or Your Money Refunded

Don't let a valuable horse go to ruin on account of a leg trouble that can be cured. Silver Spavin Compound will positively cure Spavin, Curb, Splint, enlargements and growths of every description.

Successfully used for years by hundreds of veterinarians and breeders of high grade stock. We know what it will do; our guarantee is bona fide and sweeping.

Price per bottle, postpaid, \$3.00

Davis

STOCK FOOD CO.
2323 Cottage Grove Avenue, CHICAGO

Shoo-Fly

THE ANIMALS' FRIEND
KILLS EVERY FLY

It strikes when our gravity sprayer is used. Keeps insect pests off animals in pasture longer than any imitation. Used since 1885. Thousands of dairymen duplicate 10 to 50 gallons annually after testing imitations. Absolutely harmless; cures all sores.

30 cents worth saves \$10

worth of milk and flesh on each cow during fly season. No Lice in Poultry House or any place it is sprayed. If dealer offers substitute, send us his name and \$1 for 3-tube gravity sprayer and enough SHOO-FLY to protect 200 cows. Name express office. \$1 refunded if animals not protected. Free booklet. Special terms to agents.

Shoo-Fly Mfg. Co., 1816 N. 10th St., Phila., Pa.
FARM AND FIRESIDE guarantees Shoo-Fly to be O. K.

NEWTON'S HEAVE

COUGH, DISTEMPER AND INDIGESTION CURE

The Standard Veterinary Remedy.
20 years sale. Send for booklet.

SAFE TO USE

Makes the horse sound, stay sound

DEATH TO HEAVES

The first or second \$1.00 can cures. The third can is guaranteed to cure or money refunded.
\$1.00 per can at dealers, or express prepaid.

THE NEWTON REMEDY CO., Toledo, Ohio

ARRAS CREAM SEPARATOR

Why pay a fancy price for a separator when you can buy one which produces more and better cream in the shortest time—takes up less room and costs one-tenth as much as an intricate and expensively operated machine. The

is simplicity itself. No inner tubes, corrugations, or deep angles to clean; no corrosion, no submersion, no pan lifting, no dilution. Used and proven highly satisfactory by thousands of our customers in all parts of the country. Strongly built and absolutely guaranteed. Money refunded if not satisfactory after 30 days. Send for free instructive catalogue—it contains money-getting information regarding milk and butter.

ARRAS CREAM SEPARATOR CO., 52 Main Street, Bluffton, O.

Seldom See

a big knee like this, but your horse may have a bunch or bruise on his Ankle, Hock, Stifle, Knee or Throat.

ABSORBINE

will clean them off without laying the horse up. No blister, no hair gone. \$2.00 per bottle, delivered. Book \$1 free. ABSORBINE, Jr., for mankind, \$1.00. Removes painful Swellings, Enlarged Glands, Goitre, Weus, Bruises, Varicose Veins, Varicosities, Old Sores. Always Pain. Book free.

W. F. YOUNG, P. D. F., 23 Temple St., Springfield, Mass.

Why Silage Pays

GET THESE BOOKS

If you raise stock for profit, you ought to read the latest edition of "Why Silage Pays." It is packed with surprising facts of profit-making possibilities in silage feeding, tells how and when to cut, gives endorsements of well known breeders and authorities and shows the Blizard Cutter which we guarantee. With this helpful book we include our 1910 catalog, describing and showing various sizes of our machines. Both books sent free on request. Get them now.

THE JOS. DICK MFG. CO.
1444 Tuscarawas St. Canton, Ohio

SILOS

The kind "Uncle Sam" uses. Also used by the States of Vermont, Massachusetts, Rhode Island, Connecticut, New York, New Jersey, Pennsylvania, Kansas and others. Further proof of their superiority contained in our free catalog. Send for it. Also cutting machinery.

HARDER MFG. CO., Box 31, COBLESKILL, N. Y.

CALVES

RAISE THEM WITHOUT MILK

Booklet Free
J. W. BARWELL, Waukegan, Ill.

WHEELS, FREIGHT PAID \$8.75

for 4 Buggy Wheels, Steel Tires. With Rubber Tires, \$15.20. 1 mfg. wheels ¾ to 4 in. tread. Buggy Tops \$5.50, Shafts \$2.00. Top Buggy \$3.50; Harness \$5. Learn how to buy direct. Catalogue Free, Repair Wheels, \$5.50. Wagon Umbrella raze. F. F. DODD, Cincinnati, O.

D & S

Prof. West Dodd, President of D & S Struthers, is the scientist who has taught the world how to control lightning.

Not since the days of Franklin has any scientist done as much to protect life and property from the destructive consequences of lightning as has

Benjamin Franklin, the eminent scientist who taught the world what lightning really is by a simple experiment of kite flying.

Professor WEST DODD

the inventor of the D. & S. system of lightning rod construction. The basis of this great claim is due to several very important inventions for making woven copper lightning rod cable fixtures, and equipment for lightning rod construction. This system has given to humanity safety for the home and family and protection to animal life and property.

EVERY TIME LIGHTNING STRIKES You Are in Danger

unless you have D. & S. lightning rods on your buildings. You cannot afford to take such chances. You need this protection for your home—for your property. Like other lines of business and professions, there is a difference between the real, the genuine, and the imitation or the cheap kind. You cannot afford to accept dangerous substitutes when such important principles are involved. You cannot afford to keep that good horse, or that good cow, or any other kind of live stock, in unprotected buildings—much less the home, where the loved ones abide. Think of it, man. You will not need to think long.

This is proof sufficient: in fire insurance companies report losses showing 2,950 fires in one year; 2,165 were caused by lightning, only 795 from other sources combined. Think of it, 3 to 1. That is what we save you from.

This ought to be sufficient warning to you and important enough to warrant quick action. You need lightning rod protection—you need the best. The best is the D. & S. System. D. & S. means Dodd & Struthers. We are pioneer lightning rod manufacturers. Our Woven Copper Cable, invented and exclusively controlled by us, has given the lightning rod business a respectable place among merchants and professional men everywhere, because it is right—right in quality—nothing but pure copper wire used; right in method of construction, it furnishes one of the best and most lasting conductors in lightning rod construction.

Our great book written by Prof. Dodd, entitled "The Laws and Nature of Lightning," is yours for the asking. Write for it now. Spring storms are coming. Do not delay. Such delays are dangerous.

DODD & STRUTHERS, 445 Sixth Avenue, Des Moines, Iowa

AMERICAN SAW MILLS

There's Money in Lumber

Make most money because they do best work in quickest time with least power and smallest crews, owing to their simple construction and improved, patented devices. Portable and stationary. All sizes. Variable Friction Feed, Combined Ratchet Setworks and Quick Reeder and other superior features. Free Catalog and Prices will interest you. Lists our complete line of wood working machinery.

American Saw Mill Machinery Co.
130 Hope St., Hackettstown, N. J.
1676 Terminal Building, New York

SEA GREEN & PURPLE SLATE ROOFS NEVER WEAR OUT

SEA GREEN AND PURPLE SLATE is nature's own product—not man made. Quarried from solid rock—split into convenient form for laying, and then in its natural state ready for the roof.

SOLID ROCK CAN NOT WEAR OUT. It can't burn, rust, warp, crack, tear, or decay. That's why Sea Green or Purple Slate Roofs never wear out and never require painting and repairing like all other roofing.

Sea Green & Purple Slate Roofs are suitable for any building, new or old. Give perfect protection. Reduces insurance rates because spark and fire-proof. Afford clean cistern water. Not affected by heat or cold. First cost—only a trifle more than short lived roofing. Settle your roof question for all time. Don't spend more money for poor roofing. Write to us for our free book "ROOFS"—it will save you money. Give name of your local roofer. Write today.

AMERICAN SEA GREEN SLATE CO., Box 113 Granville, N. Y.

It is to your advantage to mention Farm and Fireside in writing to advertisers. Farm and Fireside folks get the very best results.

Story of a Record-Breaking Cow

[CONTINUED FROM PAGE 9]

the country a good example of what care and attention will do. He does not trust the care of his herd to those who might be harsh or unfeeling to them. As a good proof of this it was noticed that the moment he opened the stable door while the cows were away down in the field, they all started toward him, crowding right up to him without a single sign of fear. Still when he put out his hand to hold them in check, they did not crowd him nor each other. Speaking of dehorning, he says:

"I had one cow hooked through the fence before I took their horns off. Other cows all turned against her and they came near killing her. That made me think it was best to take the horns off. The greatest objection there has been to that is the looks of the cow on exhibition; but showmen are changing their way of thinking about this. It will not long be an objection to see the cows with smooth heads."

Mr. La Munion is careful about having strangers come among his stock. Some of the heifers came close up to us and none seemed at all afraid, but we noticed that Mr. La Munion kept good watch that nothing happened to excite them. This kind of care is well worth imitation.

We made some inquiry as to the methods of summer feeding on Lockhart farm and learned that only thirty acres are actually under cultivation, about sixty being in pasture and the rest woodland. On the thirty acres, corn, grass and grain are grown. A big silo, forty feet high and sixteen feet in diameter, has recently been built, and this was filled for the first time from eight acres of corn. Grass was plowed under, and above this was a heavy coating of barn-yard manure. Little commercial fertilizer is used—little is needed, as the place is naturally rich.

From the time the cows get fairly on pasture no grain is fed. Mr. La Munion does not think it profitable at present prices of grain. From one and a half acres of alfalfa, however, he states that he fed at the second cutting his whole herd last season for thirty days. For his region at least alfalfa is a success.

This is one of Mr. La Munion's parting suggestions:

"You can make a mistake by feeding too much grain, as well as by feeding not enough. After you get up to what a cow can use, all the rest is thrown away. I have fed cows grain when if I had fed half as much I would have gotten just as good returns. You have got to study your cows and find out what every one likes, what agrees with them and how much they can take to advantage."

In the person of his wife Mr. La Munion has a most able helper. She attends in large part to the large and constantly-growing correspondence of her husband, as well as giving her household duties personal attention. It is a pleasant country home and some day will be still more so, for success must crown efforts so well directed as are those prevailing at Lockhart Holstein Farm.

How Often to Milk

THE frequency of milking is, of course, a matter that has to be adjusted to convenience of labor, and so forth, and on the farm and in the commercial dairy the twice-a-day schedule is probably the only practicable one. In the case of cows on record tests, however, and also in the case of other fine animals that are heavy producers, more milkings a day are desirable. The oftener a cow is milked, other things being equal, not only a trifle more milk will she give, but her average butter-fat test will be greater. I believe it pays to milk a cow every time she will give from ten to fifteen pounds, whether this be three or four times daily.

Whenever she is milked, it should be done thoroughly. Few milkers get all that is possible out of a cow. It should be borne in mind that the last milk is the richest and every drop of this last milk that can be got increases the test of that mess of milk. Not only this, but the stimulation given to the udder glands in obtaining this milk is helpful to them.

This was the secret that greatly aided the Jersey cows at the St. Louis fair. At each milking, after the milk had been obtained, the milkers manipulated or rubbed the udders of the cows from half a minute to a minute, and then milked out that milk which had accumulated in the udder and teats during the process. This does not mean that a cow should be stripped, but that the entire udder should be massaged, so to speak. The glands are stimulated to further activity, and not only will more milk and richer milk be obtained each time, but the same will be the result each following time. Thus persistency is added to the work of the cow, and this means high records for the year; for the cow with a big record is the one that continues her performance throughout the year instead of slacking up her pace. H. G. V. P.

A FEW OF THE MANY VERY PROMINENT MORE THAN ONE MILLION USERS OF DE LAVAL CREAM SEPARATORS

U. S. Department of Agriculture, Washington, D. C.
The Royal Dairy of England, at Sandringham, England.
Hon. Levi P. Morton, Ex-Vice-President of the United States.
E. H. Harriman, Esq., (estate of), the late great railway magnate.
J. Pierpont Morgan, Esq., the greatest of bankers.
Hon. Whitelaw Reid, U. S. Ambassador to England.
R. W. Sears, Esq., founder of Sears, Roebuck & Co.
Hon. J. M. Dickinson, U. S. Secretary of War.
Charles L. Tiffany, Esq., of Tiffany & Co., the famous jewelers.
J. C. Hoagland, Esq., President Royal Baking Powder Co.
Ex-Gov. W. D. Hoard, proprietor of *Hoard's Dairyman*.
James J. Hill, Esq., the great western railway magnate.
Clarence H. Mackay, Esq., Pres't Postal Telegraph & Cable Co.
Sir Hugh Montagu Allan, head of the Allan steamship lines.
C. P. Goodrich, Esq., the well known dairy writer.
P. E. Sharpless, Esq., of Sharpless' "Philadelphia" butter fame.
Walter W. Law, Esq., owner of the famous Briarcliff Farms.
Beatrice Creamery Co., largest creamery concern in the world.
J. Ogden Armour, Esq., head of Armour & Co., Chicago.
George Burnham, Esq., President Baldwin Locomotive Works.
Frederick G. Bourne, Esq., President Singer Sewing Machine Co.
H. N. Higginbotham, Esq., President Chicago World's Fair.
John Huyler, Esq., the famous New York candy maker.
T. Eaton, Esq., (estate of), of Toronto's great department store.
Denman Thompson, Esq., the actor of "Old Homestead" fame.
Hon. Paris Gibson, Ex-U. S. Senator from Montana.
Dr. J. A. Mead, President the Howe Scale Co.
H. O. Havemeyer, Esq., (estate of), late Pres't Amer. Sugar Co.
Henry Clay Pierce, Esq., President Waters-Pierce Oil Co.
John Newman, Esq., President Elgin Butter Board of Trade.
William A. Wright, Esq., Ex-Pres't New York Milk Exchange.
Fairfield Dairy Co., famous for its "certified" milk.
Norman B. Ream, Esq., of the Pullman Palace Car Co.
L. F. Swift, Esq., President Swift Packing Co., Chicago.
Edward D. Adams, Esq., head of the Allis-Chalmers Co.
Prof. W. H. Caldwell, Secretary American Guernsey Cattle Club.
Dr. Leslie D. Ward, Vice-Pres't Prudential Life Insurance Co.
Dr. Charles H. Frazier, Medical Dean University of Pennsylvania.
Dr. S. B. Hartman, of "Peruna" and stock farm fame.
Hon. Sidney Fisher, Canadian Minister of Agriculture.
Nathan Straus, Esq., head of R. H. Macy & Co., New York.
George Abbott, Esq., Philadelphia's largest milk dealer.
Moses Taylor, Esq., President Lackawanna Steel Co.
C. Brigham & Co., Boston's great milk dealers.
George Eastman, Esq., President the Eastman Kodak Co.
George H. Ellis, Esq., proprietor *Christian Register*, Boston.
J. R. Whipple, Esq., prop'r Touraine & Young's Hotels, Boston.
J. B. Haggin, Esq., the great capitalist and breeder.
F. L. Houghton, Esq., Sec'y Holstein-Friesian Breeders' Assn.
John Arbuckle, Esq., the great New York coffee merchant.
Col. F. P. Holland, proprietor of *Texas Farm and Ranch*.
Walter M. Lowney, Esq., the great candy manufacturer.
Mrs. Scott Durand, owner Chicago's famous "Crabtree" dairy.
S. R. Guggenheim, Esq., the American Smelting Co. magnate.
William MacKenzie, Esq., President Canadian Northern Railway.
E. A. Darling, Esq., President American Jersey Cattle Club.
Sheffield Farms Co., the high-class milk producers.
W. H. Wanamaker, Esq., the Philadelphia clothier.
Horton Ice Cream Co., the biggest concern of its kind.
P. G. Henderson, Esq., President Red Polled Cattle Club.
Hon. Wayne McVeagh, Ex-U. S. Attorney General.
Philip Moen, Esq., the great wire manufacturer.
Hon. Fletcher D. Proctor, Ex-Governor of Vermont.
Colgate Hoyt, Esq., President Automobile Club of America.
T. S. Cooper, Esq., the chief importer of Jersey cattle.
George W. Vanderbilt, Esq., owner great "Biltmore" N. C. estate.

All of the agricultural colleges and 98 per cent. of the world's creameries and butter factories.

Andrew Carnegie, Esq., the great philanthropist & steel magnate.
John D. Rockefeller, Esq., President of the Standard Oil Co.
Judge Alton B. Parker, Democratic ex-candidate for President.
Borden's Condensed Milk Co., the world's greatest milk concern.
C. I. Hood, Esq., of "sarsaparilla" and fancy cattle fame.
J. B. Duke, Esq., President the American Tobacco Co.
George J. Gould, Esq., the railway and financial magnate.
H. B. Gurler, Esq., the Dean of American dairying.
R. T. Crane, Esq., President the Crane Co., Chicago.
Hon. Seth Low, Ex-Mayor of New York City.
August Belmont, Esq., the banker and subway magnate.
Thomas W. Lawson, Esq., of "frenzied finance" fame.
Sir William Van Horne, Ex-President Canadian Pacific Railway.
E. M. Barton, Esq., Vice-President the Western Electric Co.
O. C. Barber, Esq., President Diamond Match Co.
W. Campbell Clark, Esq., of the Clark Thread Co.
James A. Rumrill, Esq., Ex-Pres't Boston & Albany Railroad.
Mrs. W. E. H. Massey, Dentonia Park Farm, Toronto.
Hon. John W. Goff, Supreme Court Justice, New York.
Hon. Thomas Ballantyne, Ex-Speaker Ontario Parliament.
J. D. Farrell, Esq., Vice-President Oregon & Washington R. R.
Col. Chas. F. Mills, editor *Farm Home*, Springfield, Ill.
Hon. L. J. Forget, Canadian Dominion Senator.
Walker-Gordon Laboratories, of nearly all the large cities.
Robert W. Reford, Esq., the steamship magnate of Montreal.
Dr. Geo. C. Mosher, owner St. Louis Fair prize dairy herd.
Hon. W. Owens, Canadian Dominion Senator.
C. A. Griscom, Esq., head of the great American steamship lines.
W. Gettys, Esq., the celebrated Tennessee Jersey breeder.
Western Ohio Creamery Co., the largest of eastern creameries.
Hon. W. B. Barney, President Iowa State Dairy Assn.
B. F. Yoakum, Esq., head of "Frisco" railway system.
Geo. Brumder, Esq., President Germania Pub. Co., Milwaukee.
Glenside Stock Farm, World's Champion Short Horn Breeders.
Neil P. Anderson, Esq., Texas' largest cotton factor.
Henry Sherwin, Esq., President Sherwin-Williams Paint Co.
Hiram Walker & Sons, Canada's greatest distillers.
J. Hendry Smith, Esq., Detroit's largest grocer.
Henry C. Wallace, Esq., editor of *Wallace's Farmer*.
Jacob Miller, Esq., Secretary International Hotel Stewards Assn.
Hon. Knute Nelson, U. S. Senator from Minnesota.
Hon. John Sundberg, Pres't Iowa Corn Growers' Association.
Victor F. Lawson, Esq., editor *Chicago Daily News*.
A. A. Hurd, Esq., General Attorney "Santa Fe" Railroad.
S. S. Carvalho, Esq., manager of the Hearst newspapers.
Frank A. Vanderlip, Esq., President America's greatest bank.
Miss Helen Gould, the great New York philanthropist.
J. H. Rushton, Esq., President Fairmont Creamery Co.
Traymore, Chalfonte and Haddon Hall Hotels, Atlantic City.
Dr. F. W. Gunsaulus, President Armour Institute, Chicago.
F. L. Daggett, Esq., Manager Fairbanks, Morse & Co.
M. S. Driggs, Esq., Pres't Williamsburgh Fire Insurance Co.
Benjamin Stern, Esq., of Stern Bros., dry goods, New York.
E. B. Thomas, Esq., President Lehigh Valley R. R. Co.
H. B. Duryea, Esq., of the famous starch manufacturers.
Hon. Wm. J. Gaynor, Mayor of New York City.
Hershey Chocolate Co., the famous chocolate makers.
Holland Dairy Co., Colorado Spring's magnificent dairy.
Ewell Farm, Spring Hill, Tenn., fine cattle and horse breeders.
"Al" G. Field, Esq., the famous minstrel as well as farmer.
Edw. R. Strawbridge, Esq., Strawbridge & Clothier, Philadelphia.
John Hays Hammond, Esq., the \$500,000, a year mining engineer.
Frank E. De Long, Esq., of "hook and eye" fame.
Hon. John Lee Carroll, Ex-Governor of Maryland.
Joseph L. Jones, Esq., President Philadelphia Milk Exchange.
John Lowber Welsh, Esq., President Keystone Watch Case Co.

The De Laval Separator Company

165-167 BROADWAY
NEW YORK

42 E. MADISON STREET
CHICAGO

DRUMM & SACRAMENTO STS.
SAN FRANCISCO

175-177 WILLIAM STREET
MONTREAL

14 & 16 PRINCESS STREET
WINNIPEG

1010 WESTERN AVENUE
SEATTLE

Haying, Harvesting and all Hurry Work

The Time to Use a
Low Wheel Wagon



ELECTRIC STEEL WHEELS

SOLVE THE PROBLEM

WRITE TO-DAY. We explain by first mail how to measure any axle; what size you need, so you can order right off. We will also tell all about our steel wheel wagons.

QUICK SHIPMENT—NO DELAYS

Perhaps you do not know what steel wheels mean—no repairs—no expense—always ready for use. A thousand advantages. Let us explain. You have a hundred and one hauling jobs before you. All summer and fall your wagon will be going, the wheels are not in any too good shape now and may go to pieces on you in the busy season.

FILL OUT THIS COUPON, or write us a postal. We will make it easy for you to order.

ELECTRIC WHEEL CO.
BOX 13,
QUINCY, ILL.

Fill out, cut off and send this COUPON To Electric Wheel Co., Quincy, Ill.

I am interested in knowing how to get a set of steel wheels or handy wagon QUICK.

Name _____

Address _____

How About Your Income

ARE you satisfied with your present income? Are you so fixed that you would not accept a chance to make more money simply by making use of your spare time? At this time, when prices are soaring higher and higher, these are questions of the greatest importance.

If you feel that your vacation this summer must be limited because of a shortage of funds, or if you feel that you would like to indulge in some other luxury for which you have been wishing for a long time; in fact, if you want to make money for anything, we can help you.

We only ask your spare time, but if you are able to devote all your time to the work, so much the better for you and for us. Some who have already taken hold are now making \$10.00 per month, some \$10.00 per week and some \$10.00 per day, dependent upon the amount of time given to it. You also can do it.

For full information write at once to

The Crowell Publishing Company
Dept. of Agents—Desk 3; Springfield, Ohio

It is to your advantage to mention Farm and Fireside in writing to advertisers. Farm and Fireside folks get the very best attention.



AMATITE means more to the man who needs a roofing than just merely something to put on the top of a building. It means a thoroughly satisfactory and reliable roof covering, without future expense for painting—because the real mineral surface makes painting unnecessary.

Frequently the cost of painting a roofing amounts to almost enough to buy a new Amatite Roof.

Amatite can be laid right over shingles, tin or other ready roofings. The directions hold good for laying Amatite anywhere and over anything, and are as simple as A B C.

If your dealer doesn't handle Amatite, write us for a sample. The sample tells the whole simple story of Amatite—why it is waterproof, why it needs no painting.

Write to-day to nearest office.

BARRETT MANUFACTURING CO.

New York Chicago
Philadelphia Boston St. Louis
Cleveland Pittsburgh
Cincinnati Kansas City
Minneapolis New Orleans London, Eng.

ANCHOR FENCE
All styles for
FIELD AND LAWN
Best material and construction.
Free sample and catalog.
Dept. D, ANCHOR FENCE & MANUFACTURING CO.
Cleveland, Ohio

Don't Rust Farm Fence
Extra heavily galvanized.
Sold direct to farmers at
manufacturers' prices. 30
days' free trial. Freight
prepaid. Also Poultry and
Ornamental Wire and Iron
Fences. Catalogue free.
Write for special offer.
The Ward Fence Co.,
Box 306, Decatur, Ind.

BROWN FENCE
For Rabbits,
Chickens, Hogs, Sheep,
Horses, Cattle. 160 styles. Big
heavy No. 9 galvanized Coiled
Spring rust proof wires. Will defy
stock, wind and weather. Free sample
& cat'g. 15 to 35c per rod. We pay freight.
The Brown Fence & Wire Co.,
DEPT. 21 E Cleveland, O.

Practical Farm Notes

Catch-Crops and How to Handle Them

ALMOST every spring, especially when weather conditions are unusual or unfavorable, many a farmer is confronted with the need of using a part of his farm with some kind of catch crop, owing to the failure of some other crop. Few farmers are so successful as to never need to use catch crops, indeed I have yet to see a farm, where general farming is practised, where they could not occasionally be made profitable. In fact, in many systems of rotation the catch crop is worked in regularly, following wheat, rye or a failure of corn.

There are many different things that can profitably be grown as catch crops, and I believe that putting in any kind of a crop is better than letting the land lie idle and grow up to weeds. For my own use I have finally simmered down my list of catch crops to two plants—the cow-pea and sorghum-cane. These might not suit all conditions and people, and, in fact, I should not recommend planting them everywhere, for other things, like millet, soy beans, a catch of rape, the vetches, etc., for different localities and purposes, might prove even more profitable than the cow-pea and the sorghum-cane. But under conditions such as ours here in southern Illinois several points determine my decision in favor of those two.

The main point that I never overlook is the maintenance of the fertility of my soil, for without this fertility I could not grow even these catch crops with profit. Next to fertility I consider the feeding value of the crop grown. In these two respects the cow-pea-and-sorghum-cane combination is as near ideal in their purpose as any crop I have ever tried or heard of. I nearly always grow the peas and cane together on the same land.

All up-to-date farmers understand that the cow-pea is a legume and the sorghum-cane is not. But I do not consider the latter unprofitable on that account. In this sorghum-cane I have a feed that is fine for all kinds of stock, even horses. For my cows I do not find anything better in the forage line, except some of the legume family.

It is a fact not generally understood that growing and continually taking of cow-peas and clover will deplete the nitrogen in the soil. The plant when harvested will take as much nitrogen out of the soil as it puts back or a little more. Yet we must produce feed and

at the same time maintain the supply of plant-food in the soil. Yes, we must not only maintain, but increase that supply, or we are not up-to-date farmers. So, in using these catch crops, we must not think of them always as a "taking off" proposition; but we must, at times at least, take the old plow out and roll them under to rot in the soil and make humus and increase the supply of nitrogen.

The cow-pea is in my judgment almost an ideal crop for increasing the nitrogen supply when turned under. The sorghum-cane, of course, does not gather nitrogen, but takes it away; but being a very deep-rooted crop it puts the soil in fine condition down deep and liberates plant food that is locked up there, besides fitting the soil to work under other treatment more readily.

Getting the land ready for the catch crop is not often a very difficult task with me. In case of a failure of corn from bad seed, worms, cold, overflow or any cause, I usually take four good mules, a good sharp disk and a small-tooth smoothing-harrow and put the land in nice order in a hurry. I let the disk go down about four inches deep. Even if the land is packed somewhat, it will cut it up fine and the harrow following it makes an ideal bed for the seed of the catch crop. Should the land be rough, it may be necessary to double disk it. In such case I double disk, sow my peas at the rate of one to two bushels per acre, depending on the strength of the land and what I intend to do with them, then harrow once and sow my cane-seed at the rate of one half to one bushel to the acre, then harrow lightly again. Thus the land is put in fine condition and the seed properly covered and even in dry weather under such preparation the seed will germinate and grow readily, until in a short time the land will be shaded enough to prevent much moisture escaping.

I nearly always sow a catch following wheat, for I do not want the weeds to grow up rank and seed the land. If the spring has been rather moist and the land has not been packed by excessive rain, I usually follow just about the same plan as described above for the catch following corn, but if the land has become packed hard, it may be necessary to plow immediately after harvest. In such case I stack the wheat as soon as possible, then all the plows available at once begin turning the wheat-land, with the roller following to crush all the clods and hard lumps. Then two good mules pull the disk over this, for it is not necessary to do anything except just loosen the land.

Following this disking I now sow the peas and harrow, then sow the cane-seed and harrow again lightly. The cane-seed are not sowed at the same time with the peas because they do not need to be covered so deeply as the peas. By harrowing the land the first time the disk furrows are leveled somewhat so that the cane-seed are left nearer the surface. Thus they germinate quicker and get through the ground more easily. When they first sprout they are quite tender and if they have very far to go before reaching the surface, they are likely to not get through at all, or at least come through slowly, and what I want is a quick germination and rapid growth from the start.

At the time of year when we must sow the catch crop it is likely to be very dry; thus it is very necessary that we use some crop that will resist drought and at the same time make growth. In these respects few crops equal the cow-pea and cane. I have often sown cane when the land was very dry, but pulverized well, and though no rain came for some time, the crop came up surprisingly, anyhow. Peas resist dry weather almost as well, and the two together make almost an ideal growth. The cane holds the peas up off the land so they can be mowed better.

R. B. RUSHING.

Western Canada Demands Government Elevators

[CONTINUED FROM PAGE 4]

which the farmer deposited and brought an inferior price.

The grain-growers, then, have formulated the demand for government elevators. To them the elevator is as much a public utility as a street-car service is to the city people. The Manitoba government has already passed such legislation; and the Saskatchewan administration has agreed to appoint a royal commission, with the same end in prospect. Here are the six planks of the

grain-growers' elevator platform for each province:

(1) That the government provide storage elevators at each shipping-point; the cost to be met from the grain passing through them.

(2) That the offer be made to purchase the existing elevators upon a fair valuation of their actual worth or at an estimate at which they can be duplicated under the new system.

(3) That the elevators be absolutely controlled by a commission of competent men, nominated by the Grain-Growers' Association and appointed for life by the lieutenant-governor-in-council; the commission to be beyond the reach of any party influence and to be perfectly independent, subject only to the Legislature or the Court of Appeal.

(4) That the employees of the elevator system be engaged by and responsible only to the commission.

(5) That the elevator operators weigh and take careful samples of all grain stored in their elevators.

(6) That particular attention be given to special binning, so that the identity of the grain be preserved from the farm to the miller.

What do the grain-growers hope to gain by this system, which will not cost the public treasury anything? It will cost nothing, because the government, which is the farmer in his collective capacity, will only have to act as banker for an enterprise which has, and which must always have, the first call upon the produce of the country. It is fearlessly asserted that for the last three years farmers have had to accept for grain sold on the street from six to ten cents a bushel less than they would have got if they had loaded direct into the car. Of course, there are many farmers who have been selling their own grain at the head of navigation, and every year there are more who can afford to do it. But for the rest, who have not yet come so fully into their own, it is intended to save that six to ten cents. The governments have shown their hand, and it looks a good hand to the grain-growers.

Driving Tuberculosis Out of Dairies

[CONTINUED FROM PAGE 5]

of course, important not to test any animal which shows a preliminary rise of temperature or which is suffering from garget, abscess, or any acute disease. Animals should not be tested in very hot weather or under exposure to extreme heat. With the observance of these common-sense precautions, the test can be relied upon with great certainty.

It is, of course, important to use reliable thermometers. Do not trust to the cheap thermometers bought at the ordinary drug-store. If it is impossible to obtain thermometers with certificates, they should be tested by placing in warm water and comparing with a thermometer of known accuracy.

The process of making tuberculin renders it free from all germ life. In addition to this it is carefully filtered, and the dilution with carbolic acid prevents all danger that living germs may be present in it. It is, therefore, sterile fluid and incapable of producing tuberculosis. An enormous number of tests made by skilled veterinarians and scientists in every part of the world has shown that its injection is absolutely harmless when made into healthy animals. Further than this there is no indication that the use of the tuberculin test will cause chronic tuberculosis to light up into a rapid form of the disease. Observations on this point have been made on thousands of animals in Denmark, Germany, the United States and other countries.

In summing up, then, we would say that tuberculin is a safe and very sure method of detecting tuberculosis, even in its early stages, in cattle. Its use is not injurious either to healthy animals or to those having the disease.

Don't haul off the brush. Burn it on a poor spot, for the ashes.

A big incinerator (place to burn trash) is a necessity on every farm. It may be made about four feet high, of stone. All the trash and dead animals can be turned into ashes there with no danger of the fire spreading.

A generous sprinkling of millet or cane-seed on the early potato-patch after laying it by will keep down the weeds that always spring up, and will also furnish you some very desirable roughage to add to your winter feed-supply.

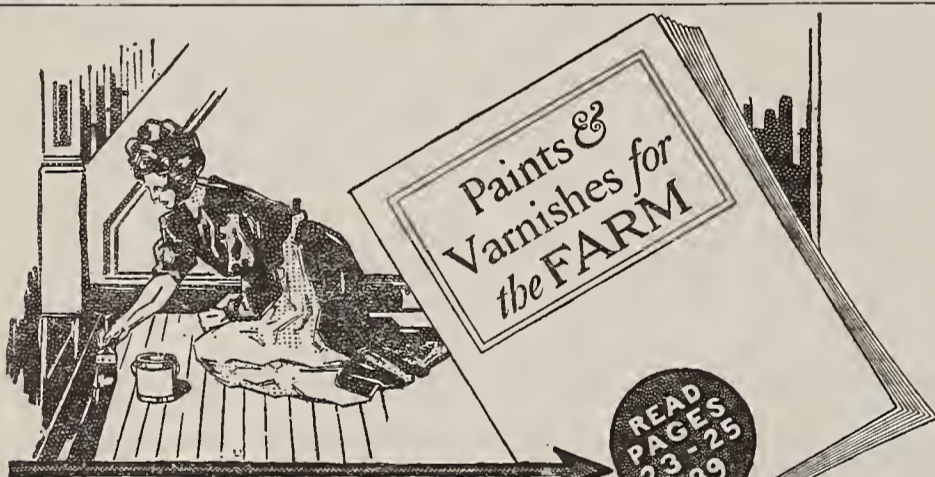

Painting About the House

THIS big 116 page book is free. It tells not only all about painting everything around the house, giving full information on the particular paint for every special purpose, such as enameling your kitchen cupboard, painting or varnishing your floors, finishing wood-work, screens and porches, but it also covers the entire subject of painting about the farm, giving exact information as to just what paint to use on what and why.

SHERWIN-WILLIAMS

PAINTS AND VARNISHES FOR FARM USE

The one way you can be sure you are getting the best paints for whatever purposes you require is to buy Sherwin-Williams' Paints. Only in the Sherwin-Williams' line do you find a paint especially made for every special requirement. If you want to paint your barn, use Sherwin-Williams' Commonwealth Barn Red; for your implements, Sherwin-Williams' Wagon and Implement Paint; for your buggies and carriages, Sherwin-Williams' Buggy Paint. And so it is, all through the line—a special paint for every purpose about the farm. The Sherwin-Williams' dealer in your town can furnish you with a special Sherwin-Williams' Paint for any requirement.

SHERWIN-WILLIAMS
PAINTS & VARNISHES

Address all inquiries to The Sherwin-Williams Co.,
691 Canal Road, Cleveland, Ohio.
In Canada, to 639 Center Street, Montreal.



The FARMERS' LOBBY.

By Judson C. Welliver

A SURVEY of the situation in Congress at this time seems to justify the belief that the long session is going to accomplish more in the direction of carrying out the so-called "Roosevelt policies" than the country has seemed to anticipate. The best information places the date for probable adjournment somewhere between June 15th and July 1st. A few months ago the leaders in both Houses hoped the sessions would be ended by May 15th.

Of the nine administration bills designed to strengthen the government's hands in control and conservation of national resources, the one of most immediate importance has already passed the House. Introduced by Representative Pickett, of Iowa, it is designed to legalize all the withdrawals of public lands made under both Roosevelt and Taft, for which the legal authorization has been regarded as very dubious. The bill also gives the President full authority to make further withdrawals whenever he deems them necessary and provides that lands once withdrawn may not thereafter be restored to entry without an order of the President.

The difficulties of conservation legislation are well illustrated by the history of this bill. As first introduced, and as reported from the Public Lands Committee of the House, it was far from satisfactory to the conservationists. When the bill came up in the House the insurgent Republicans and some of the Democrats made a fight for a series of amendments and succeeded in greatly improving the measure. At this writing the bill is being tinkered with in the Senate Committee on Public Lands. Under the insistence of President Taft and pressure of popular demand the measure will probably become law in some form during this session.

The Committees on Public Lands have been struggling with measures to provide for disposal of the surface of public lands, while retaining in the government the ownership and control of coal under the land. The demand for such a policy as this has become very strong in all parts of the country. The plan involves working out a detailed project for leasing the mineral deposits, to be worked by private enterprise, under the government's regulations, on payment of some fixed royalty per ton of coal taken out. This plan is already in operation as to Indian lands in Oklahoma. One of its most important benefits would be the restriction of combinations and monopolies. The government would reserve power to rescind any lease on a showing that a combination had been formed to prevent competition or charge excessive prices.

Saving the Nation's Coal

SUCH a measure as this would be in line with the enlightened policy of the German empire, where legislation has recently been passed forbidding any more privately-owned coal-mines to be opened at all. The difficulty lies in working out legislation that will be applicable in all parts of the country. In Alaska, for instance, a set of problems are presented, involving transportation, land laws, etc., which are about as different from the problems of Wyoming or Oklahoma coal-mines as they well could be.

Working out the details for an intelligent administration of the public domain will require years. But if the President is authorized without delay to withdraw public lands whenever he sees fit, the public interest will be in considerable measure preserved. The Geological Survey is making very careful studies of the mineral lands within the public domain, and when these are completed it will be possible for the President, by withdrawals, to put an end to private raids on the public coal deposits and to keep these deposits securely in the public control until Congress shall get around to pass legislation for their operation and administration.

One important bill which occupied a prominent place in the administration program for this session is now law, the new Employers' Liability Act. Three years ago Congress passed such an act and the Supreme Court held it unconstitutional. The new measure is designed to meet the objections raised by the Supreme Court, and incidentally it greatly strengthens the rights of injured employees. It provides that personal injury cases may not be transferred from the state to the federal courts. Railroad companies especially and industrial corporations to a great extent have made it a policy whenever possible to transfer such cases from

the state to the federal courts; and the federal courts by reason of their generally unsympathetic attitude toward the plaintiff, have come to be regarded as pretty nearly hopeless in such actions. In addition to forbidding such transfer in future, the new act provides that if at the time an employee is injured a railroad is engaged in an unlawful act, then the railroad may not set up as defense the plea that the injured employee was guilty of contributory negligence. For instance, if there is a car in the train on which the safety appliances are in defective condition, that constitutes an unlawful act. If, then, an employee on that train suffers injury, though it have no relation whatever to the particular defect in the safety appliances, the railroad is estopped from pleading that the employee's negligence contributed to bring about his injury.

Postal Savings Bill a Political Shuttlecock

THE bill to establish a postal savings bank system has made little progress since it passed the Senate. The long consideration of the measure there brought out very definite evidence that the leaders in that body were willing to establish a postal savings system only on conditions that would make it a useful adjunct to Senator Aldrich's project of a central bank of issue. The particular thing which stands between Senator Aldrich and the commitment of powerful financial interests to his central bank plan is the fact that there are outstanding about seven hundred million dollars of two-per-cent. bonds, most of them held by national banks. The national bankers are able to use these as security for government deposits and for the issue of national bank notes. If a central bank were established, it would receive the government's deposits and, presumably, it would take over the power of issuing circulation. Thus the national banks would find themselves with the two-per-cent. bonds on their hands, purchased originally at a considerable premium, but of no value as security for currency issues or for government deposits. Inevitably, these two-per-cent. bonds would shrink considerably in value.

Senator Aldrich designed to have the savings deposits of the postal banks invested in these two-per-cent. bonds, so that they could be taken up without any loss to the bankers and thus put an end to the banker's opposition to the central bank. But Senator Borah and other insurgents forced an amendment providing that the funds of the postal savings banks should be invested in securities bearing not less than two and one fourth per cent. interest. This shut out the two-per-cent. bonds. With this and various other amendments the bill passed and it is now in the hands of the House Committee on Post-Offices. The best evidence concerning the attitude of the House is that that body will not be willing to strike out the Borah provision. Whether the House, under the domination of Speaker Cannon and his allies who, in a general way, are in sympathy with the Aldrich plan, will be given a chance to pass the bill at all, is still uncertain. But even if the House does pass it, with the Borah provision, the measure would have to go to a conference dominated by men strongly opposed to this feature, and in all probability would die in conference.

How Congress Really Feels About Campaign Funds

I HAVE seen no better illustration of the difficulty of passing legislation to which the titular leaders of the two Houses are opposed than is afforded in the case of this bill. It is believed that the Aldrich forces will prefer to prevent postal savings bank legislation on any terms unless they can have it on their own. Senator Borah's followers are positive that if the Borah provision is stricken out of the bill, they can muster the vote to defeat the legislation entirely. And I should venture the guess that there probably will be no postal savings legislation at this session.

The fate of the bill to require publicity of the contributions and expenditures of campaign funds also hangs in the balance. Last Congress a bill of this kind seemed certain to pass the House. The "regular" organization, which was violently opposed to such a law, introduced and adopted an amendment to reduce the representation of the Southern states in the House in proportion as they should disfranchise negroes. With this amendment the bill had no possible chance of

getting through the Senate, because the Southern senators would talk till doomsday to kill it. The amendment was hitched to the bill in the House with the deliberate and successful design of killing it.

The organization in the House had small disposition to take chances of such a situation arising again, and so when Speaker Cannon named the committees for the present Congress this particular committee was selected with the purpose of preventing such a bill being reported. The Speaker judged his men accurately enough, but one day when the committee met two or three opponents of the bill were absent, and by a bare majority of a quorum the Publicity Bill was reported out. Thereafter, the measure was finally forced to a vote in the House. It is one of those bills which most congressmen secretly oppose, but publicly pretend to favor. A record vote being assured, it was very certain to pass, as it did. It is now pending in the Committee in the Senate, and the chances are that no action will be taken on it at this session. So many important matters are always crowded down into the small end of the funnel at the conclusion of the session that the managers are usually able to block any particular measure to which they entertain objections. And a measure looking to publicity of campaign contributions and expenditures is this year highly objectionable to many of both Republican and Democratic leaders. Not in a good many years have the Democrats entertained such strong hopes of getting a good slice of the campaign funds, as this year. They believe that the big interests, which for a long time past have been giving their money to the Republicans, are going to divide up this year, in the belief that the Democrats have a good chance of winning anyhow and that it would be just as well to be on good terms with both sides.

The Much Revamped Interstate Commerce Bill

THE consideration of the administration bill for amending and strengthening the interstate commerce law has developed a situation whose final phases it is impossible to forecast at this time. The bill was originally drawn by Attorney-General Wickersham. It was introduced in both Houses, referred to the respective committees on interstate commerce and by both was reported. The House Committee pretty thoroughly rewrote the measure and made it, from the standpoint of advocate of effective regulation, a much better measure. The Senate Committee, on the other hand, made no important changes in it, and the Senate progressives promptly opened their fight on the floor. The conservatives have won at nearly every point, so that at this time there is presented a curious spectacle of a bill, introduced in the same form in Senate and House, the Senate version of which has been kept steadfastly conservative, while the House version has been day by day growing more and more radical. By an overwhelming majority the House adopted an amendment providing for a valuation of all the railroads in the country. This is a proposal which the railroads, for reasons not very apparent to anybody but themselves, have long opposed with peculiar zeal. It would not be at all surprising if the entire piece of legislation would finally fall because of the wide divergence between the House and Senate views.

Several weeks ago when a Democrat moved to declare the Speakership of the House vacant about half the Republican insurgents voted against the measure, and Speaker Cannon was left in the chair. Since that time the Speaker, seemingly confident that his enemies had lost their one opportunity to accomplish his undoing, has indulged various expressions of contempt which have served to roil up the insurgents in a most uncomfortable way. As a result, it is now intimated that the insurgents propose, with Democratic assistance, before the end of the session, to force the adoption of an amendment to the rules which will deprive the Speaker of the power to name the House committees. That much accomplished, they will, in the last hours of the session, offer a resolution declaring the Speakership vacant; and they expect that this resolution will carry. Thereupon the members of the House will go home to their constituents, the Republican party will be relieved of much of the onus of the anti-Cannon issue and by the time Congress comes back next winter it will be possibly pretty accurately to gage public opinion and to determine what sort of a Speaker ought to be chosen.

SUBSCRIPTION PRICE

One Year (24 numbers) 50 cents
Canadian Subscriptions . 1 Year, 75 cents

Entered at the Post-Office at Springfield,
Ohio, as Second-Class Mail Matter.

Subscriptions and all editorial letters should be sent to the offices at Springfield, Ohio, and letters for the Editor should be marked "Editor."

The date on the address label shows the time to which each subscriber has paid.

Subscribers receive this paper twice a month, which is twice as often as most other National farm journals are issued.

Silver, when sent through the mails, should be carefully wrapped in cloth or strong paper, so as not to wear a hole through the envelope.

When renewing your subscription, please say it is a renewal, and if possible send the label from a recent copy. If all our subscribers will do this a great deal of trouble will be avoided.



PUBLISHED BY
THE CROWELL PUBLISHING COMPANY

SPRINGFIELD, OHIO

Branch Offices: 11 East 24th Street, New York City

Tribune Building, Chicago, Illinois

Copyright, 1910, by The Crowell Publishing Company

ABOUT ADVERTISING

FARM AND FIRESIDE does not print advertisements generally known as "readers" in its editorial or news columns.

Mention FARM AND FIRESIDE when you write to our advertisers, and we guarantee you fair and square treatment.

Of course we do not undertake to adjust petty differences between subscribers and honest advertisers, but if any advertiser in this paper should defraud a subscriber, we stand ready to make good the loss incurred, provided we are notified within thirty days after the transaction.

FARM AND FIRESIDE is published on the 10th and 25th of each month. Copy for advertisements should be received twenty-five days in advance of publication date. \$2.00 per agate line for both editions; \$1.00 per agate line for the eastern or western edition singly. Eight words to the line, fourteen lines to the inch. Width of columns 2 1/4 inches, length of columns two hundred lines. 5% discount for cash with order. Three lines is smallest space accepted. Letters regarding advertising should be sent to the New York address.

Remove the Oleo Tax—and Then What?

THE pressure of the interests to secure the repeal of the tax on colored oleomargarine is stronger now than ever before. That there is any prospect that it will be repealed few farmers have suspected. But an answer of the editor of the dairy department of the Southern Cultivator to the inquiry of a subscriber who asks if the paper would advise one to go into dairying in the face of this proposed change in the law is disquieting to those who may suspect that writers in close touch with the cotton-seed oil men may know more than others of the power behind the demand for the repeal.

"Do you think it wise," asks this subscriber, "to engage in dairying in the face of the proposed legislation to legalize the artificial coloring of oleomargarine?"

"I cannot advise you," says the editor, "to go into butter dairying. If you are so situated as to be able to sell milk and cream, the outlook is more hopeful, but even this will be less profitable because of increased competition from dairies that will be driven out of butter-making."

The Southern Cultivator is one of the cotton-belt papers which have lent their aid to those asking the repeal of the oleo tax. If its dairy editor is not mistaken, such papers ask in the interest of cotton-seed oil the repeal of a tax which is the only barrier between the dairying interests and ruin, both North and South. That our contemporary understands this is made clear by further quotation from the same article. "In my opinion," says the dairy editor, "the removal of the tax on colored oleomargarine will sound the death-knell to butter-making. The manufacture of oleomargarine is so skilfully done that none but an expert can detect it from creamery butter; and although the law requires that it be sold as oleomargarine it is in nearly all cases sold as butter. Oleomargarine costs not exceeding one half as much as butter, and in most cases much less than half. It is made by the immensely rich packers of the West."

The dairy interests have no moral right to ask the government to keep out of the markets in their interests a new article of food; but both dairymen and consumers have the right to demand that no new article be fraudulently substituted for an old article, and by such fraud an ancient and immensely important industry in which millions of small producers are making their living be crushed by a trust, which will thereby get its clutches on another source of the people's food-supply.

The tax on colored oleo is not defended as a revenue measure. It is a tax on fraud. It is not intended as a means of collecting funds for the government. Like the tax on dogs, it is designed to get rid of the thing taxed. In our opinion, the Southern cotton interests would be vastly more benefited by a prosperous dairy interest than by a problematical increase in the price of cotton-seed oil—to be paid by the Beef Trust. But the point is this: If the prospects for repeal are such as to make it unwise for the Cultivator's correspondent to enter the dairy business, how about the millions already in it? Ought they not to bestir themselves? Another matter to write about to congressmen and senators.

* * *

Sow a piece of alfalfa near the house for the hens.

Since living costs so much, there is still less excuse for living a worthless life.

Don't fight over the line fence. Fix it or make a new one. Then you are safe from trespassing stock.

If the rising sun greets the farm boy already about his tasks, let the setting sun smile upon him freed from them.

Speaking about honesty, an old Confederate soldier who was drawing from his state five dollars per month wrote in not long ago to be dropped from the roll, as his financial status was such that he no longer needed assistance.

Mend your ways and your highways.

If you don't like the idea of being the under dog, don't be any dog at all.

Speaking of dehorning, why not apply some caustic potash to that incipient grouch?

We need an Abraham Lincoln to set free the dish-rag slaves of the present day.

The Press Leads; Uncle Sam Follows

FARM AND FIRESIDE is flattered when the Department of Justice follows its example—and investigates on its trail.

More than a year ago we began the publication of a notable series of articles by Mr. G. C. Streeter on the relations of the farmers to the price-fixers. These articles, we believe, have been one of the important influences leading up to the present investigation by the Department of Justice of the whole matter of illegal control of prices.

On April 21st the Chicago Board of Trade was shocked to learn that agents of the government were at work among them to find out just what the relations of that body to the prices of farm products really is.

On May 2d the despatches from Washington state that "assurances" have been given by the Chicago Board of Trade—and, of course, other bodies of the same sort are acting with Chicago in this matter—that "corners" will positively not be permitted any more in the arena where Joe Leiter and Phil Armour had their historic battle. It is stated that the Chicago people in the grain and provisions trade are fearful that Congress may enact a law forbidding dealings in "futures," and thus end the Board of Trade as a really "influential" body. In our issue of March 10th Mr. Welliver told our readers of that passage-at-arms between Mr. Burleson, of Texas, and Mr. Marsh, of the New York Cotton Exchange, in which Mr. Marsh at a committee hearing strongly urged that dealings in "futures" are a necessity of modern business. "Then," said Mr. Burleson, "I should think there would be just as much need of a wool exchange, so that people buying wool could somehow get the advantage of this system of 'hedging' which the cotton exchange people present as their chief justification for existence."

And Mr. Welliver adds: "Mr. Marsh didn't get past that point. Nobody else has." And still wool is sold successfully with no gambling in "futures," so far as we know.

It is such articles as Mr. Welliver's, from the legislative standpoint, and Mr. Streeter's, as reports of special investigations, that are bringing about these investigations. Public opinion is aroused. The spirit of inquiry is abroad. The gambling on the great grain and cotton markets runs very deeply into our business life. Great claims are made that it is a necessity of modern business. If so, it has nothing to lose by the most searching investigation of its reason for existence or its methods. Of one thing we are certain: The unorganized farmers cannot expect to benefit by artificial control of prices. Such control will never be exerted to the end that more will be paid for the subject matter of the betting than is absolutely necessary. FARM AND FIRESIDE expects in the future, as in the past, to be something more than an indifferent spectator in the fight for justice to the producer.

* * *

There is no use to cry over spilt milk—especially before it is spilled.

Gullies are wrinkles on the face of the earth, which if allowed to grow make the land look old.

Good intentions do not build good roads, no matter if they do have a reputation as paving-stones on the road to a certain undesirable destination.

The man who takes the time to dig up a decaying stump rather than plow around it year after year is the kind of a man who would not hesitate to remove other difficulties.

A Permanent Advance Needed

THE article elsewhere in this issue by Mr. Edwy B. Reid on agricultural education contains a thought with which we are in hearty sympathy. We want a permanent advance along this line, not a temporary dallying with a fad. Such an advance must be deliberate and of deliberate purpose. The equipment and personnel must be assembled. The teaching force must be trained. And, above all, the rural population—with which we are dealing here—must come to realize that the welfare of rural life depends on education for rural life.

We think, however, that some of Mr. Reid's ideas are of the sort that will stand in the way of the success of the reform. "The child," says Mr. Reid, "ought to obtain a goodly amount of cultural training along with the professional work." And again, "He must not be deprived of many of his high-school studies now offered, in order to introduce the agriculture and manual training."

It may as well be understood at once that the successful training of children in agricultural and manual skill and knowledge cannot be piled upon the already top-heavy structure of the courses of study. If these things are to go in, other things must come out. And why not? The "Nature study" of the schools gives no knowledge of Nature or of natural science worth mentioning. Its design is merely to face the child's mind toward Nature, not to teach science. Education in either school or college is to be estimated not by the distance it takes the mind, but the direction in which it has started it. If agriculture is introduced into the course of study, it may well absorb and take the place of all other "Nature study." For it has the same educational function. It faces the mind toward the world of Nature and fills it with scientific thoughts.

In most schools physiology is a part of the course. In the properly-devised agricultural common-school course exact knowledge of the follicles of Lieberkuhn (of which the writer first learned in a country school in Iowa) and such interesting anatomical facts may well be sacrificed to the physiology of animal husbandry. The mind of the child will be directed to as important physiological facts and principles as those dealt with in the school physiology of the day.

All these distinctly agricultural studies are also broadly cultural. Nothing cultivates the mind so deeply or so inspiringly as the application of science to life. Languages will come within the desires of the boy or girl who seeks the last word in science. And when it comes so, it is vitalized as a part of life. We have not yet passed the age when some minds still hold to the ancient error that there are "cultural" things worth doing for the mere sake of the mental training involved; but we are passing it rapidly. For there are so many fields of educational endeavor now open, which combine utility with the highest demands on the reason and the most exalted cultural value, that the doing of things that are merely cultural will soon be recognized as a crime against childhood.

The Comet and the Weather

ON MARCH 28th of this year it was hot all over the Northern states. Thousands of people said it was the comet. Four weeks afterward it was snowing over much of the North. Most of the same thousands of weather experts said it was the comet. Add these two quantities of weather lore and average them, and the results will be the influence of the comet on the weather. The spring has been an abnormal one, but just as crazy weather has been known from time to time always, comet or no comet. At this writing, the real damage to fruits, gardens and crops has not been assessed. That it will be large no one can doubt. Frost is a thing against which the gardener and orchardist has no remedy—if it is really severe.

Smudges and fires to keep frost from forming have had their chance to be tried this spring as never before. We should be glad to hear from our readers everywhere as to their success in frost-fighting. The brethren everywhere are anxious to know the results, with data as to temperature and cost of firing.

Just Tell Me You Are Mine

Words by Harry D. Kerr

Music by Ted. S. Barron
Composer of "Billy,"
"In Sunny Africa," etc.

Valse moderato.

Two lov-ers were
They sat 'neath the

stroll-ing one mid-sum-mer's night, Down by the old riv-er side, — Each mind-ful of naught, save the moon shining
vine cov-er'd ar-bor so still, Each lov-er so bashful and shy, — While the moon sink-ing slow-ly far o-ver the

bright, And with him all lov-ers con-fide. — Their hearts were as light as the birds in the trees, that sang to each
hill, Look down with a smile in his eye. — The fu-ture so bright seem'd to them but a day, while soft-ly he

oth-er so gay, — And the song that was echoed from o-ver the breeze, seem'd softly and sweet-ly to say: —
ask'd her to wed, — Then hold-ing her close in a strong man-ly way, he sweet-ly and ten-der-ly said: —

CHORUS.

Just tell me you are mine, dear, for I'm in love with you, — Tell me the old sweet

sto-ry, tell me, that you'll be true, — Give me your promise, sweet-heart, on-ly a

word or sign, — Whis-per love's dear-est an-swer, Just tell me, that you are mine. —

Copyright by Leo Feist, Feist Building, New York
International Copyright Secured and Reserved

The Genuine **BAKER'S** Breakfast Cocoa



with the *delicious natural flavor* and the rich red-brown color characteristic of this high grade cocoa is made only by

Registered U. S. Pat. Office
Walter Baker & Co. Ltd.
Established 1780 DORCHESTER, MASS.

The more you eat

Quaker Oats

the better your health will be.

Practical experiments with athletes show Quaker Oats to be the greatest strength maker.

56

STEM-WIND-SET **EARN** WATCH RING and CHAIN
BY SELLING 18 CARDS OF 10c. ART JEWELRY
WE GIVE a plated gold watch like picture, or a watch 5 years, (together with chain), also imitation DIAMOND RING having two sets for selling 18 cards of jewelry at 1c. each. **ORDER WATCH for selling 24. Order jewelry—sell it—send pay—get premiums.**
L. H. Spencer, Horton, N. Y.

GROWING CHILDREN

The Period when the Nervous Activity is at Its Greatest

"Against the practice of giving tea and coffee to children, we cannot speak too strongly. Childhood is the period when the nervous activity is at its greatest. The brain is ever busy receiving new impressions. Reflex action, co-ordination of muscles, and the special senses are all under a special course of training.

"The nervous system is pushed to its utmost capacity, and long is the list of victims that follow its over-stimulation. In these little people nothing but harm can come from the use of such cerebral stimulants as tea or coffee. Bad, then, as this practice is, let us as physicians be aggressive in its prohibition.

"Do not be satisfied by answering 'No' when asked as to their use, but let us teach the families with whom we come in contact that such practice is evil. We speak emphatically, because not only among the poor and uneducated, but among the rich, who should know better, this practice is marvelously prevalent."—*The Home Doctor.*

Children like a warm beverage for breakfast and it is well for them to have it if the drink is a food and not a drug.

Postum is made to supply a rich nourishing liquid food with a crisp coffee taste for those who cannot and should not use coffee. Analysis shows it to contain about fourteen per cent of muscle-forming elements and 66.11 per cent of energy- and fat-producing elements, which go to nourish and sustain the delicate nerve centers throughout the body and from which the vital energy proceeds.

The success of child or adult depends largely upon proper sustenance for the body. Children who depend upon the intelligence of their elders to furnish them with good food deserve our most careful attention and thought.

Read "The Road to Wellville," found in pkgs. "There's a Reason."

When Grampa Was Little

By Eugene Wood, Author of "Back Home," Etc.

Illustrated by Fred E. Lewis



"Brother Detwiler . . . is more apt to make more fuss off for Cleveland"

IN SOME ways grampa isn't a bad sort of a relation to have. This is not to be taken as a sign that I am going back on gramma at all. I think that on the whole she makes more allowance for little boys being little boys than grampa does. And again, he is more apt to make more fuss over his granddaughters than such unworthy creatures deserve, being only girls, anyhow. But he has pleasant ways of making willow whistles and flutterwheels and all such, and when the notion takes him and he gets started, he tells what he did when he was a little boy just about so big, or, as he comically puts it, "knee-high to a duck." I suppose ducks must have knees, but I must say they are very modest about it, and seemingly always remember to "keep their coatsies down."

Grampa must have had about the nicest and smartest dogs when he was a little boy that there 'most ever were, lots nicer and smarter than modern dogs. And there were more funny goings-on then than in the gray, gray days of now. For example, if Casebolt's "yaller" dog, a mean, slinking, egg-sucking hound, came prowling around your place and you wanted to get shut of him, would it occur to you to take and tie onto his tail (with a waxed-end so's it wouldn't slip off) a dried beef-bladder with some grains of corn in it to make a rattling sound and scare that dog pretty near to death? No. It wouldn't. Your pa doesn't make shoes for all of you and doesn't keep waxed-ends. And your pa doesn't kill his own beef and you wouldn't have any beef-bladders to play with like grampa. It must have been the funniest sight on earth to see that dog light out from there, "I yoop; I yoop!" and if you want to just about kill yourself laughing, you want to get him to tell you sometime how he served that dog of Casebolt's.

When grampa was a little boy, there weren't any Injuns around—that is, not regular Injuns working steady at their trade of killing folks and peeling a piece off the top of the head of each one to take home and hang up as a souvenir. But grampa's gramma was right in amongst 'em, as you might say, and he told grampa about them, when grampa was a little boy the height of a duck's knee, and grampa tells, as he heard them, stories that—Geeminently! Why, your mouth gets all dried up inside listening to them, and when it comes time for little boys to climb the wooden hill they have out at grampa's place, they have to hold on to their Aunt Car'line's hand all the way up to the spare bedroom and she has to sit by them till they go to sleep and tell them there aren't any more Injuns, and, anyhow, they don't hurt good little boys that always remember to "stomp" the mud off their feet before they come in the house, and don't run after the gobbler or the guinea-fowl or anything.

It seems a long, long time since there could have been Injuns around, the place is so all built up like. You don't realize how long till grampa comes to visit at your house, and gramma comes, too. I mean your other gramma. You've got one grampa dead and one gramma dead. Not these, but the others. I mean you've got one grampa dead and one gramma dead, so's there's one of each set. Oh, you know what I mean. And when they meet at your house



"Women and children in the North were just as truly chattels"

they get to talking over old times and how folks used to do, it seems so far away and so remote in history you wonder they don't remember seeing Noah or George Washington or Richard the Lion-hearted or some of those old Scripture worthies.

Why, just for instance, grampa was fourteen years old before he ever had on a pair of shoes that were rights and lefts. One day he'd put a shoe on his right foot, and the next day he'd change it to his left foot. Oh, by golly! He had to. If he forgot and his mother saw that the bulge his right big toe had made in the leather the day before wasn't over his left little

toe, she'd haul off and let him have a clout on the ear that'd make him think his head was a yaller-jackets' nest, it'd hum and sting so. His pa had enough to do to make shoes for the whole family besides his other work, without careless little boys running their shoes over on one side and wearing them out unevenly.

Grampa's pa could not only farm it, but he was also a sort of a carpenter (had to be one), and he could blacksmith pretty good (had to do that, too), but his strong "holt," as you might say, was making shoes. Supposing there was a lot of rails he wanted split and he was kind of putting it off because splitting rails isn't quite the same kind of a job as eating your dinner, and somebody would come along and ask him to make him a pair of shoes, grampa's pa would trade off his labor making shoes for this other man's labor splitting rails. And gramma remembers, too, how one winter Elias Powell was at their house, oh, for as much as a month, "scutching" flax or "hetcheling" flax or whatever the word was that gramma used, fixing the flax-straw so's it could be spun into thread or linen, and he got for his pay his board and a whole lot of blue-jeans that gramma's ma had woven. She had bought the cotton warp and dyed it in the "blue-pot," and the woolen yarn she had spun and dyed herself, and then she wove the wool and the cotton into jeans, and 'Lias took it home with him and was very well satisfied with the fine bargain he had made.

They figured out how much his wages would come to in money and then they figured how much the jeans was worth a yard, and that's the way they settled accounts. The money hadn't anything to do with so much gold and so much silver. It never has, really. It's just an abstraction that kind of gives you a notion of the amount of bother a person is put to to render a social service. It was and is a kind of common denominator to which you reduce

'Lias Powell's work in "hetcheling" the flax and gramma's ma's work weaving the blue jeans. The exchange or barter or trade or swop or whatever you're a mind to call it was intended to be on an even-Stephen basis, an equal amount of social service for an equal amount of social service, neither one expecting to get more out of the bag than he put into it.

Even when it seemed that somebody got more out of the bag than he put into it, that wasn't quite the case. As, for instance, the miller. You had your big wheat-stack that sometimes stood there for years, the straw outside getting black as tuck, but the wheat inside being just as good as ever. Come along towards fall, the farmer would thresh out enough wheat for the winter's flour for his family and haul it to the mill and have it ground up. The miller didn't give back all the flour and bran and stuff that much wheat made, but he took toll of it, enough to give him his wages and to keep up the mill and provide for its wear and tear. Or if the farmer took his rye to the distillery and got in exchange the whisky he had to have in the house in case of a bad cold or a snake-bite or a wedding or a funeral or some other festivity, the distiller likewise did not give back in trade an equal amount of whiskey, but took his toll, providing wages for himself and the up-keep of the distillery.

Everybody expected to have to work for a living and expected to have about so good a living if he was industrious and capable and didn't get into debt or back another man's note. All he asked for was that he should exchange his labor on an even-Stephen basis for anybody else's labor.

They hardly ever saw money. Didn't have much use for it except to pay taxes. Oh, if a man wanted to buy another piece of land or a yoke of oxen or a horse (you could get a mighty fine horse in those days, grampa says, for fifty dollars), he'd haul his wheat to the warehouse whenever he happened to be going to town. And when he had hauled in all he meant to haul, he and the warehouseman would count up what it came to, and then the warehouseman would take his key and unlock the door of the green-painted cast-iron safe and take out bags of money. Here and there would be one of these "dollars of the daddies" there used to be talk about some years ago, but mostly they were Mexican dollars with an eagle on the back perched on a cactus bush and holding a snake in its bill. You had to remember they were worth only ninety-five cents. And there would be halves, and quarters, and dimes, and half-dimes, and three-cent pieces that were so thin they'd get under your finger-nail, and big two-cent pieces, and coppers a little smaller than a bread-and-butter plate. And the farmer would go out of there jingling like a string of sleigh-bells. There was no paper money if the farmer was smart enough to know that Red Dog currency might or might not be good, but there might be the printed promise of some entirely trustworthy merchant to receive that piece of paper in exchange for goods. Certainly there was no long, slim slip of paper by which book credit was transferred from one column of the bank's ledger to another column. There were no checks, those devices by which

toll is taken by those who neither hetchel flax nor weave blue jeans, but simply permit exchange to be made.

Now when everybody's licking into his work from sun-up till dark producing victuals and clothes, and when everybody exchanges the product of his labor on an even-Stephen basis there is just naturally bound to be a surplus. Smoke-houses get full of meat, and there is flour a plenty, and wheat standing in the stack out of which to make more flour, and there is cider and vinegar, and out in the apple-hole are apples more than you can possibly eat, and potatoes and linen laid by against the time when not only Polly Ann will get a man, but Jerusha and Minerva Jane and Alfaretty (and she's only a baby), and there is blue jeans till you can't rest and woolen cloth and linsey-woolsey and all kinds of stuff. The folks that had come West in a covered wagon, poor as Job's turkey and poorer, too, got fat and sassy. If they had been living in a time when folks fought only with pikes and swords and bows and arrows, some of the rough-scut and rowdy element would have dressed themselves up in iron clothes and gone and plundered the farm-houses so cram-jam full of good things, it being easier and more exciting to fight for it than to farm for it. And then these rough-house gangs, as in all other countries, would have come to be nobility and gentry, and have looked down on the farmers off whom they lived and from whom they took just enough to keep them poor all the time and not so much as to discourage them entirely. But our folks from the very beginning had guns with which they were pretty handy, and iron clothes aren't any protection against rifle bullets, so it wasn't healthy to get up marauding gangs of that kind. However, there are more ways of killing a dog than choking him to death with butter.

About the time when grampa was a little bit of a boy the folks had kind of got out of conceit with "tree" molasses and "tree" sugar. It was so kind o' common. Little did they think that this day would come when pure maple molasses is about the uncommonest thing you know of. Real cane-sugar was the thing, this dark brown, waxy sugar with big lumps in it, so very much sweeter than the chemically pure granulated sugar you get nowadays. And if they had cream-colored moist sugar to set out for company that was as stylish as anybody need look for. It took a powerful lot of work to make "tree" sugar, even if you had your own sugar-bush. There was tapping of the trees, and setting the buckets out to catch the drip, and carrying the sap with these shoulder-yokes, and "b'ilin' down," and "sugarin' off," all work for the men folks. A pile of work and expensive, too, when you consider how high wages were, thirty-seven and a half cents a day. Bother for bother, it was much better to trade off the labor of those who worked for their board and clothes (the women and children) at churning butter and gathering eggs, for the labor of those who also worked for their board and clothes, cutting sugar-cane and grinding it. You must not forget that negroes down South were not the only slaves in those days; women and children in the North were just as truly chattels, although they couldn't be sold, because there is no market for what there's such a great plenty of. So the butter and eggs that weren't needed



"The rowdy element would have dressed themselves up in iron clothes and plundered the farm-houses"

were taken to town and traded for cane-sugar and for coffee and tea and rice and raisins and pepper and spices and tobacco. Where grampa and gramma lived wasn't much account for tobacco; frost came too soon. And you mustn't think that trading grampa's ma's butter and eggs for tobacco was a jug-handled bargain, in which grampa's pa got all the best of it. Women folks in those days smoked a pipe as well as men folks.

Let's see now. I think it was A. J. Detwiler that kept the general store in New Caledonia where folks did their trading, Jackson Detwiler they called him. I bet you can't guess what the A in his name stands for and what his pa's politics were. Well, sir, I didn't think you were as smart as that. Brother Detwiler sold shoes and sugar and even silk over the same counter. He sold tar to grease the wagon-axles over the same counter that he sold New Orleans molasses. You could easily tell the difference between tar and New Orleans molasses. By the taste, of course. And Brother Detwiler did not take in much real money, either. He traded and bartered like the miller, taking his toll in the same way, allowing himself a living and the necessary expense of keeping store and taking those terrible trips he had to take from time to time away, way off to Cleveland or Cincinnati to get his stock of goods replenished from the firms to which he had shipped the butter and eggs he took in trade. Because, of course, he didn't sell butter and

eggs to the folks in New Caledonia who naturally all kept their own cows and chickens. They got very good prices for eggs in those days. Grampa remembers his ma selling a whole big wash-tub full of eggs for three cents a dozen. He remembers what a pile of groceries she got for it. Among them was indigo for blueing the wash. Starch? Why, no. What would she get starch for? She made her own starch. She remembers her ma starching things with sweet skim-milk. Laundry-soap? What would she buy laundry-soap for? She made that herself, too. Brother Detwiler didn't keep laundry-soap or any other kind, except a few chunks of Castile soap with a clean, rankling sort of smell for such as were too stuck-up to wash their faces with soft soap. Brother Detwiler had no wash-boards or wringers or clothes-lines or clothes-pins, because in those days the women folks rubbed the clothes between their hands or "battled" them on stones; they wrung them with their hands and spread the wet things on bushes to dry.

Now, a body can listen to grampa's stories of how they used to do when he was a little boy, can cluck the astonished tongue with "Ts! Ts! Ts!" and shake the head and grunt "m-M!" in wonder how they ever got along and be, for all that, little the wiser. They thrive and prospered mightily. And you remember that I told you that there was no gang of iron-clad ruffians to take their surplus away from them. Also, a body can kind of study over grampa's stories and try to put this and that together and see how it came about that the surplus gets away from the farmer, and still there be no marauding gangs in iron clothes.

This was all "before the war," you understand. I mean the big, big war which was fought to free the slaves down South, the one, you recollect, in which the British captured Washington and burned the House of Representatives, and our government had to take to the woods and hide out, the one in which the only land battle we won was fought

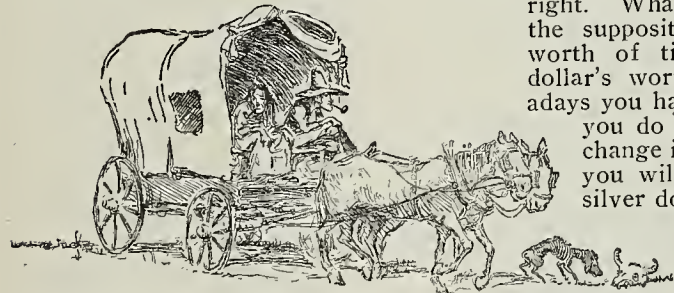

"The folks that had come West in a covered wagon"

after peace had been declared and all our claims had been disallowed. Anyhow, after this big, big war not only the black slaves down South were freed, but also the white slaves up North (the women and children), although in a much more unostentatious way.

The farmers had been having things their own way in this matter of trading freely the product of their labor for the product of the labor of other people in this and other countries. And the surplus over and above what would keep them in good shape certainly looked tempting, and wearing iron clothing and raiding smoke-houses had gone out of style too long ago to talk about.

The shoes that grampa's pa made were clumsy, unlined cow-hide things that would fit one foot as well as the other. Machinery was invented which could make rights and lefts and make a whole, whole lot more with the same amount of human time and energy expended than grampa's pa could turn out. And machinery could weave and spin a whole, whole lot more cloth with the same amount of time and energy than gramma's ma could turn out. I suppose that in the time that grampa and gramma have been changing from little tow-heads to bent and tottering old folks the amount of goods that can be turned out with the same amount of time and energy that they put in on the job must be, anyhow, a hundred times as much. In some cases it is a thousand times as much. The amount of crops a farmer can raise, though, hasn't increased in anything like that proportion. But if we were now going on the proposition to exchange time and energy on an even-Stephen basis that would mean that the farmer would get a hundred times as much for his crops as he did when grampa was a little boy. I hardly think that's the case, in spite of what I



"It isn't as good business as putting on iron clothes and raiding a farmer's smoke-house"



"Women folks in those days smoked a pipe as well as men folks"

read about how all the farmers these days are riding around in automobiles.

But if, instead of this even-Stephen business, so much time and energy for an equal amount of time and energy, you fixed it so that the price of the shoes should not come down to the cost of getting them made, but only far enough to discourage grampa's pa from making shoes by hand, and the price of cloth come down je-e-est far enough to keep gramma's ma from spinning and weaving on her hand-loom, why that would obviate the necessity of going to the tailor and being measured for a suit of iron clothes, while still accomplishing about the same thing. So, after the war had quieted down, the people who made shoes and cloth by machinery gained control of the law-making power, and the farmers lost it, and haven't got it back since.

Also, the man who traded off his labor splitting rails might have wanted hog-meat rather than shoes. In which case he would have had to find somebody else than grampa's pa to work for. But if grampa's pa could have sold the shoes he made and paid the money to the rail-splitter, and the rail-splitter had bought the hog-meat, all on the even-Stephen basis, that would have been all right. What money there was on the supposition that it took a dollar's worth of time and energy to mine a dollar's worth of gold or silver. Nowadays you hardly ever see gold, and when you do get hold of a gold piece you change it as quick as you can for fear you will pass it for a penny. And silver dollars bag the pockets terribly.

So we have paper money, and increasingly we balance our accounts with checks which transfer book credit from one column of a bank's ledger to another column of a bank's ledger. Whenever we want to trade one kind of labor for another we've got to be beholden to a bank. If you liken this exchange of one kind of social service for other kinds of social service to a tide that ebbs and flows, that tide must ebb and flow through banks. The toll the banks take is a shade better than the toll the miller used to take when you took wheat to be ground into flour. I saw in the paper the other day that one bank in 1908 declared a dividend of forty per cent, and the statement was made that the same bank in flush times declared a dividend of one hundred and nineteen per cent on its capital stock. Even at that it isn't quite as good business as putting on iron clothes and raiding a farmer's smoke-house. I don't know how the knights of old calculated their dividends. It's like the man that was asked by a lady what percentage of profit they ought to make on articles sold at a church fair. "Young lady," he said, "that's not in my line. That gets out of percentage and into larceny."

Well, sir, there's no doubt there have been wonderful improvements in all directions since grampa was a little boy. If you ask grampa, though, if he thinks we are better or worse off nowadays than they were then, it kind of puzzles him to give the right answer. But he minds the first school he taught. He got twenty-five dollars a month and "found" himself, and paid a dollar and a half a week, six dollars a month for board and lodging.

"Was it good board?" he repeats after you. "Well, you couldn't get such board nowadays for money. Them days what they made they made for themselves, and they tried to see how good they could make it. What folks make nowadays they make to sell, and they try to see how mean and 'on'ry they can make it and still sell it."



WANTED-RIDER AGENTS

IN EACH TOWN and district to ride and exhibit a sample 1910 Model "Ranger" bicycle furnished by us. Our agents everywhere are making money fast. Write at once for full particulars and special offer. NO MONEY REQUIRED until you receive and approve of your bicycle. We ship to anyone, anywhere in the U. S. without a cent deposit in advance, prepaid freight, and allow TEN DAYS' FREE TRIAL during which time you may ride the bicycle and put it to any test you wish. If you are then not perfectly satisfied or do not wish to keep the bicycle you may ship it back to us at our expense and you will not be out one cent. **LOW FACTORY PRICES** We furnish the highest grade bicycles it is possible to make at one small profit above actual factory cost. You save \$10 to \$25 middlemen's profits by buying direct of us and have the manufacturer's guarantee behind your bicycle. **DO NOT BUY** a bicycle or a pair of tires from anyone at any price until you receive our catalogues and learn our unheard of factory prices and remarkable special offer. **YOU WILL BE ASTONISHED** when you receive our beautiful catalogue and study our superb models at the wonderful low prices we can make you. We sell the highest grade bicycles at lower prices than any other factory. We are satisfied with \$1.00 profit above factory cost. **BICYCLE DEALERS**, you can sell our bicycles under your own name plate at double our prices. Orders filled the day received. **SECOND HAND BICYCLES**—a limited number taken in trade by our Chicago retail stores will be closed out at once, at \$3 to \$8 each. Descriptive bargain list mailed free. **TIRES, COASTER BRAKE** rear wheels, inner tubes, lamps, cyclometers, parts, repairs **DO NOT WAIT**—but write today for our Large Catalogue beautifully illustrated and containing a great fund of interesting matter and useful information. It only costs a postal to get everything. Write it now. **MEAD CYCLE CO. Dept. B-83, CHICAGO, ILL.**

Get a Watch and Fob Without Cost

Boys: Here is your chance to obtain a handsome and useful watch, having a leather fob and gilt metal charm engraved with your own initial letter without cost.

DESCRIPTION: This watch has a handsome nickel case, with open face. It is a stem-wind and a stem-set, just like other high-priced watches. It has a close-fitted snap back. It is only 3/8 inch in thickness. It is a perfect timekeeper, tested and regulated before leaving the factory. It is engraved front and back, and is a watch of which any one would be proud.

The Fob is of handsome black leather with a polished buckle, like illustration, with a rich gilt charm engraved with your own initial.



MOVEMENT: Regular 16-size. Lantern pinion (smallest made). American lever escapement, polished spring. Weight, complete, with case, 3 ounces. Quick train, 240 beats to the minute. Short wind, runs 30 to 36 hours with one winding. With each watch a guarantee is given for all repairs free for one year.

How to Get the Watch

You can get this dandy watch and fob very easily. Write a postal card to the Watch Man. Tell him you want to get this watch and fob without spending one penny. He will be glad to help you get your watch. Thousands of delighted boys have secured their watches this way with the help of the Watch Man. You can do it, too. Any boy that really wants one can easily get this fine watch. But how will the Watch Man know about you if you don't tell him. Write a Postal To-Day to the

Watch Man, FARM AND FIRESIDE, Springfield, Ohio



A Sign of Luck

Horseshoe—Wishbone—Rabbit-Foot—4-Leaf Clover
Silver Spoon—Swastika (Indian Sign)—Horsechestnut

Six Wonderful Post-Cards in Beautiful Colors and Gold

These six post-cards are the most beautiful you ever saw. Each card has a beautiful girl in some special costume. Then, best of all on each card is a famous lucky sign, or emblem. These are world famous signs of luck believed in by most of us a little. They are printed in many brilliant colors

and have a gold frame about a quarter of an inch around. They are simply wonderful. FARM AND FIRESIDE is glad to send them to you. You will be delighted for they certainly are the handsomest post-cards we ever had. We want every reader to have a set, but not more than one set to a family.

Get Them To-day

We will send you this set of Luck Sign Post-Cards by return mail without cost if you will send your name and address and inclose six cents in stamps to pay cost of handling and postage.

While They Last—One Set to Each Family
FARM AND FIRESIDE Springfield, Ohio

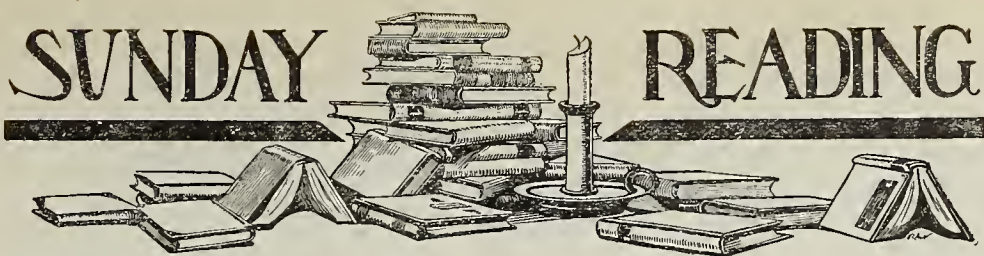

A Memorial Day Sermon

By Rev. Charles F. Weeden, Pastor of Harvard Church, Boston



IN THE foremost rank of memorials stands the monument to the soldier. The myriad mounds of rank and file stir tender and deep emotions. The veterans of the thrilling scenes of '61 and '65 are passing. Over forty-eight thousand in 1909 answered the last taps. Memorial Day should be sacredly kept and should most properly recall the stirring events of the Civil War. "What mean ye by these stones?" the descendants of Joshua asked, as they saw the memorial pile by the River Jordan. So the youth of to-day inquire of the silent sentinels raised to commemorate the soldier of '61. We have only space for one or two lessons. These sentinels are eloquent teachers. They speak of

Patriotism

You cannot analyze it. It is subtle, but it is true. It often "sleeps like the lamb, but roused from its lethargy breaks out with the strength of the lion." Never was patriotism more sublime than in the soldier of '61.

I am reminded of an example of patriotism not usually known. Colonel Shaw, whose monument of bronze stands upon Boston Common, is not alone in deserving such a memorial. Up among the Berkshire Hills there is a modest shaft that marks the grave of another gallant leader of negro troops. I refer to Colonel Chauncey Bassett, of the Bassett Grand Army post of Michigan, the grandfather of my children and the father of that elect lady, my wife. How Colonel Bassett inspired his men is illustrated by the heroism of a negro lad who was the color-bearer. As Colonel Bassett handed the flag to the lad, he gave this charge: "My boy, bring back the colors or tell to God the reason why." All through the fierce fight they watched that standard. Once it was seen to fall—the lad's arm had been shot. But grasping the staff with his left hand, the flag moved forward again, waving over the dusky troops. Once more it swayed and dropped. But after the battle they found the little fellow prostrate upon the flag wet with his blood. He could never bring the colors back. He had told to God the reason why.

But I recall a memorial which comes close to every veteran in the land. It is the name endeared to you by a thousand recollections and sends the warm blood throbbing through your veins. It is the dear name of

Comrade, Comrade

Your companions in arms! They have fallen, but your thoughts bring the old familiar forms and scenes back again. You sleep in the same tent and perchance share the same blanket or you watch by the camp-fire warming and sheltering your comrade from the cold and the storm as he has done for you. You divide your scanty rations or you dispense the lucky catch of poultry or bacon; you cheer him on the hot and dusty march; he stretches his hand or musket to you in the struggle through the dangerous swamp; he fights by your side in the din and smoke of attack; he runs and cheers with you in the gallant charge or he stands near you on the man-of-war's deck and hurls defiance at the enemies' shot. He laughs, he sings, he shouts; he turns with stern resolve and face like flint to meet the bullet-storm. His joys, his sorrows, his glory, his hardship, are yours for all the while, it is comrade. It may be one to-day, another to-morrow, for you follow the same flag. You remember well when he fell at your side and the sad tidings you sent to his home and the story of his bravery; and how tenderly his comrades bore him away and buried him sadly and reverently beneath the stars. Or, perchance, you yourself lay wounded and faint, and comrade put the ready canteen to your fevered lips; aye, it may be that after the strife you lay near one who wore the gray, and under the truce of the wounded he may have ministered to your exhausted body even while his own life was ebbing away; and all the while it is comrade. Side by side you rush to battle or you famish in prison; you jest or you weep manly tears; together you share defeat, together you awake the echoes of mountain and valley with the ringing huzzas of victory.

It has chanced that he lies yonder near or far away and that it was you who sent the last love token to his home, you who are spared to honor his grave, and yet beneath or above the sod it is always the same, my comrade.

I cannot forbear to mention one more important lesson from the monuments of the war. It is this:

The God of Nations Gave the Victory

The Almighty's hand has never been withdrawn from history. In the darkest hour a Lincoln's brain and heart—a true statesman's hand—grasped the helm and held the nation to her course through whirlwind, victory and dire disaster. In critical hours when foreign powers would smile encouragement to our foe God sent a strong man across the waters to speak for us—a man of silver tongue, the orator's fire and the patriot's soul, who averted the threatened blow. Some well remember what utter consternation swept over the North when the "Merrimac" sunk the "Cumberland" and the "Congress" surrendered. When that same evening the news sped over the wires that the "Monitor" had arrived at Hampton Roads, the air rang with shouts and men who seldom acknowledged divine interference were saying, "How providential!" Merchants of war-time will not forget the terrible depression in business. For ten years previous two thirds of the country's exports consisted of cotton from the South. How could the great loss be met? In '61 and '62 there was drought in England and Europe. Then the farmer stepped to the front. The fields of America, particularly in the West, were, in these years, unusually abundant, and foreign ports were opened to receive "a value of over two hundred million dollars of the products of our soil. England sent us more than sixty million dollars of gold." At the last when the nation was weary the indomitable Grant came into leadership and by his sledge-hammer blows, "By the left flank, forward!" gave the Confederacy the fatal stroke. Thus did the King of Nations shield this land.

Think not, fellow-citizens, that your duty is done; that in rearing colossal statues your obligations are fulfilled. The peculiar institutions of this country are the memorials God commands you to build, support and protect. See to it, you who fought gallantly for your country and you who to-day reap the harvest of heroism, see to it that your influence goes abroad for pure morals, and guard as your life the sanctity of every American home. The American boy is a splendid fellow. These soldier traits—loyalty to duty, reverence for law, obedience to seniors, fidelity in friendship, courage for the right—these virtues will crown that splendid fellow and make him every square inch a man! Again the solemn charge comes from the God of your homes, the God of your fathers and the God of your country that you maintain an honest ballot, that you encourage the teachers of our public schools, that you stand back of your town government in the enforcement of the Civil Law, that you promote the cause of temperance in private and in public, that you practise a spirit of friendliness, forbearance, peace and good-will toward the stranger. Think not that the struggle is over. "After the battle of arms comes the battle of history." Put the old martial fire of the "embattled farmers" and deep conviction of the minute men of '75 into your politics! It is not time to abandon service for luxury or indulgence or for money. Show the sturdy patriotism of '61 for justice, for truth, for purity, for honesty, for our King and for His righteousness!

The future of our nation lies in what citizens make it to-day. The world is looking to America. There are no new continents. "There is no other race that possesses, as does the Anglo-Saxon, liberty and a pure religion," and these are the mighty factors that will determine the future of the world for good.

Friends, we are still in the "broad field of battle," still in the "bivouac of life." Who will be the hero? Your answer will be in the sincerity and courage with which you defend the institutions and the liberties of your citizenship. Hold the nation's life sacred. Bare your head beneath the folds of her flag bathed in the blood of your fathers and countrymen!

From Oven Door to Farm House Door

That sums up the whole story when you buy soda crackers by name—

Uneda Biscuit

As soon as they are baked they are placed in moisture-proof packages. In this way they are kept free from dust, damp and other harmful conditions.

This means that you are *always* assured of fresh, clean, crisp, unbroken soda crackers no matter *where* you buy them or *when* you eat them.

They come in five cent packages.

(Never sold in bulk)

NATIONAL BISCUIT COMPANY

This Air-Rifle

Without Cost

For You

This is the wonderful King Air-Rifle. It is a Repeater—shoots 150 times without re-loading. It is just the rifle for a Boy. Here is your chance—you can get it without cost.

Would You Like to Get One?

You can get one without spending a cent. FARM AND FIRESIDE will help you earn it. You would be glad to do just a little work to get it. Thousands of happy boys already have earned a rifle easily from FARM AND FIRESIDE.

A True Shooter

Boys, this rifle shoots accurately. Look out, crows and hawks, if a boy ever gets after you with this King Air-Rifle. It cultivates trueness of sight and evenness of nerve.

It uses no powder—makes no noise—uses air and shot. You will have use for it every minute.

Expert workmanship has made this a wonderful gun. This rifle is provided with pistol-grip, true sights, and is so strongly made it is almost impossible to get out of order. It is extremely simple in construction.

Any child can use it and become an expert shot. It makes boys grow to be manly, self-reliant men. Every boy should learn to handle a rifle. It makes them healthy and strong—sends them out of doors.

Any boy would be happy to get this rifle. No wonder every boy should want one, we are glad to help every boy get one—without having to pay a cent for it.

How to Get It

You can get this wonderful rifle without spending a penny if you will do a little work for it. Send in the coupon to-day to the Rifle Man or just write a post-card—say you want to earn a rifle. We will be glad to help you.

Write To-day

For Our Boys

Fill out and mail the coupon below and we will send full particulars by return mail.

The Rifle Man

FARM AND FIRESIDE, Springfield, Ohio.

Please tell me how I can get the famous King Air-Rifle without having to pay a cent for it.

Name

Address

Madison Square Patterns

Designed by Miss Gould



SOME of the very smartest of the new dresses for summer this year are the simplest in design. What is known in Paris and New York as the peasant type of gown is particularly fashionable and yet nothing could be more simple to make. A dress of this sort is illustrated on this page.

THE tailored waists are less severe than they were last season. Many of them are made with a side frill. Generally, this frill is white, but sometimes it is edged with a bit of color. A pattern for a waist of this sort is shown in No. 1519. Blouses suggesting the sailor style are also fashionable.



No. 1519



No. 1534

No. 1535



No. 1517

DO you need a new skirt or two to add to your summer wardrobe? If you do and you are planning to make it yourself, use pattern No. 1528 illustrated on this page. It is just the skirt pattern you need. Its price is but ten cents and yet from it you can make two entirely different skirts which answer two entirely different needs. For instance, if you want a fancy skirt of dimity for a summer dress or one of crepe or foulard to wear with lingerie waists, you can cut one from this pattern which will make just the prettiest sort of skirt for afternoons and evenings. Of course, this skirt should be cut with the gathered flounce and the drapery should be used. Draped skirts are the most fashionable this season for dressy occasions.

No. 1519—Shirt-Waist With Side Frill
Cut for 32, 34, 36, 38 and 40 inch bust measures

No. 1534—Peasant Waist
Cut for 32, 34, 36 and 38 inch bust measures

No. 1535—Straight Skirt Gathered at Back
Cut for 22, 24, 26 and 28 inch waist measures

Madison Square Patterns

THESE are the patterns that are right in fit, right in style and right in price. For every design pictured on this page we will furnish a pattern for ten cents. If you are preparing your summer outfit, the waist and skirt designs illustrated on this page will be a great help to you in choosing what is fashionable. Yet at the same time these designs will be easy for the home dress-maker to develop into good-fitting clothes.

We have a liberal offer to make you in regard to these patterns. Here it is: We will give one Madison Square pattern if you send us only one new subscription to FARM AND FIRESIDE for eight months at the special price of twenty-five cents. The subscription must be for some one not now a subscriber to FARM AND FIRESIDE. This offer holds good up to July 1st. Send orders to the Pattern Department, FARM AND FIRESIDE, 11 East 24th Street, New York City.

Follow these directions when ordering patterns: For ladies' waists, give bust measure in inches; for skirt, give waist measure in inches; for misses' and children, give age. Don't fail to mention the number of the pattern you desire. Satisfaction guaranteed.

A distinctive feature of the Madison Square patterns is the originality of their designs—up to the moment in style, but never extreme.

If you have not seen the new pattern catalogue of Madison Square patterns, you will find it to your interest to send for it. The price of this catalogue is ten cents. Order catalogue from the Pattern Department.

THEN if you want a tailored skirt of linen or some woollen material and will cut it from this same pattern, without the drapery, you can have one that is not only very smart and tailor-made, but one that represents the newest of this season's designs. It has a plain upper portion with the lower part of the skirt plaited in groups and it is these two features which stamp a skirt as this year's model. This is a good pattern, too, for making over a last year's skirt, for the underskirt of the draped model can be of some plain material with the overskirt in a fancy design, and the tailored skirt can have a plain top with the lower portion of some striped fabric.

No. 1517—Plaited Waist With Rever Collar
Cut for 32, 34, 36, 38 and 40 inch bust measures

No. 1528

Pattern cut for 22, 24, 26, 28, 30 and 32 inch waist measures. Length of skirt all around, 42 inches. Material required for skirt without drapery, 26 inch waist measure, seven and one fourth yards of twenty-two-inch material. Material required for skirt with drapery, 26 inch waist measure, eleven and three fourths yards of twenty-two-inch material

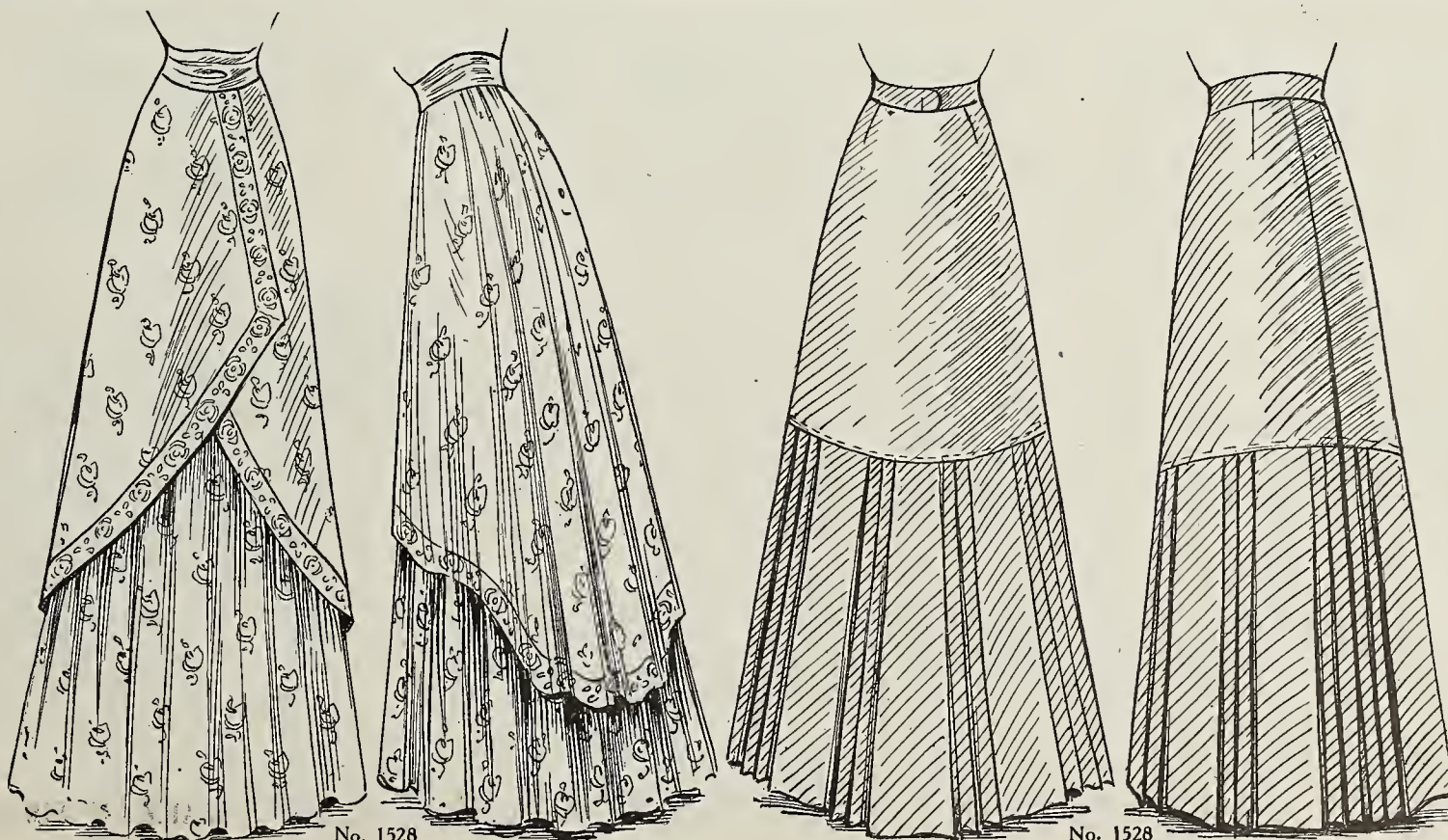

No. 1528

No. 1528

There is nothing more practical made than a Madison Square pattern. If you are in doubt about this, just try one of these patterns. They are perfect in their grade, each piece is lettered and they are most simple to use.

It is economy to use Madison Square patterns. With the exception of the sets of patterns, the price of each pattern is always ten cents. Send orders to the Pattern Department, Farm and Fireside, 11 East 24th Street, New York City.

Greatest Pony Contest

This Beautiful Pony Will Be Given Away To Some Boy or Girl

This is "Fuzzy"
He is to be Given Away
On July 30th by Farm
and Fireside

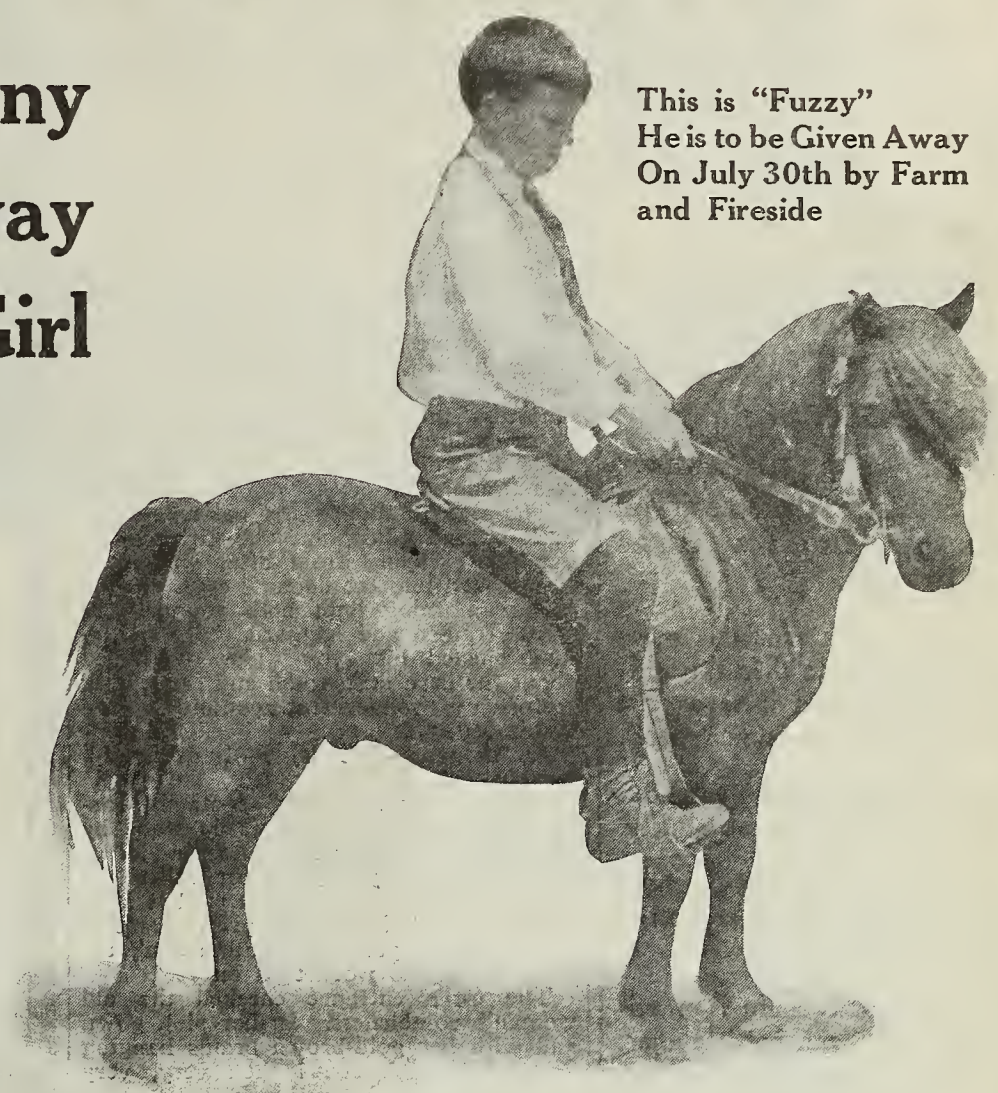

Do you want this pony? His name is Fuzzy and he is to be given away by FARM AND FIRESIDE on July 30th to some lucky boy or girl. The winner of Fuzzy will also receive Fuzzy's handsome cart and harness which is shown in the picture below. You've got the finest chance in the world to win Fuzzy if you will do a favor for FARM AND FIRESIDE.

Fuzzy is the most beautiful pony you ever saw. He has a long soft mane and tail, and kindly eyes. He can travel almost as fast as a horse, and yet he is as gentle as a kitten. And my, how he loves children.

Fuzzy, with his cart and harness, make the snappiest, handsomest pony outfit in the land. He would take the blue ribbon at many a fair. Wouldn't you be proud to own Fuzzy and totake your friends for a drive. You can own him this very summer if you get started right away and hustle enough.

You Can Be a Winner!

because absolutely every Enrolled Contestant will get a valuable prize. Just think, as soon as you become an Enrolled Contestant you are sure of a prize—absolutely sure—we guarantee that. Thousands of dollars in ponies, prizes and rewards will be divided among our boys and girls. The prizes include Fuzzy and two other beautiful blue ribbon Shetland ponies, with their outfits complete, and three magnificent \$600 pianos. In addition, the Pony Man will give away one hundred Grand Prizes, including bicycles, guns, sewing-machines, cameras, talking-machines, and almost everything else that you could wish for. FARM AND FIRESIDE guarantees that everybody who takes part in this contest will be fully rewarded for all time spent. You can't lose. You are sure to win one of these prizes:

- Three Beautiful Shetland Ponies**
- Three \$600 Harrington Pianos**
- 100 Magnificent Grand Prizes**
- A Prize For Every Enrolled Contestant**

All you have to do to win Fuzzy is to get enough friends to subscribe to FARM AND FIRESIDE. That should be very easy because FARM AND FIRESIDE is the best farm journal published, and because all your friends will want to help you. We want every FARM AND FIRESIDE family to be represented in this great contest. We guarantee a square deal to every one who takes part in it. To begin with, we will allow a cash commission on every subscription in addition to the ponies and all other prizes.

Write to The Pony Man To-Day

The important thing to-do to-day is to write to the Pony Man to-day to save you a place for Fuzzy. He will at once send you, free, a lot of pictures of Fuzzy and the other ponies, pictures of the pianos and grand prizes and will tell you just how to win Fuzzy. He will send you a lot of other valuable material, too. Write to-day. It won't cost you a cent.

Yours for Fuzzy,
The Pony Man.

P. S.—If you want to make sure of a prize right away, you won't wait till you hear from the Pony Man, but you will start right out to-day and get 10 people each to give you 25 cents for an 8-month subscription to FARM AND FIRESIDE. Then you will be a prize winner sure. Keep five cents out of each 25 cents you get for yourself, and send the rest to the Pony Man. Send your letter to



"Fuzzy" With His Cart and Harness

Pony Man, FARM AND FIRESIDE, Springfield, Ohio

Send This Coupon or Write to the Pony Man.

DEAR PONY MAN:—
Please send me at once all the pictures of the ponies and all the other things you promised and tell me just how to win "Fuzzy." I am anxious to win "Fuzzy," so save me a place in the contest. I will send my ten subscriptions as soon as possible.

NAME

R. R. OR STREET

TOWN

STATE

EASTERN EDITION

LIBRARY
JUN 11 1910
Department of Agriculture

FARM AND FIRESIDE

THE NATIONAL FARM PAPER



ESTABLISHED 1877

JUNE 10, 1910



A Visit With the Editor

I HAVE lost my copy of the old Independent Fifth Reader. I wish I had it now. There is in it a poem—I think it is one of Bryant's—about tree-planting. One line of it has clung to memory since the time when I read it in class—in District Number Nine, Colfax Township, Grundy County, Iowa.

If the teacher of that school—blessings on her work—will look over the old registers, she will find my name the winter I read in the Independent Fifth—I am not going to tell how long ago, but a lot of teachers have come and gone in that district since.

But about tree-planting. The line I have never forgotten is this: "He who plants a tree, plants a hope."

I have just finished planting two thousand hopes in the form of apple-trees. No, not in Iowa—West Virginia. It's different farming from everything I have been used to. In Colfax Township we used to think any field with two or three of those old granite boulders in it pretty stony. In the new farm are fields with plenty of stone for fencing purposes. Some places it was hard to find shovel-room when digging the holes for the apple-trees or dirt to fill them with when dug.

And yet the two thousand hopes planted are stronger and brighter than if set out in the black glacial drift of Iowa. Not that apples can't be grown in Iowa, for they can be, and are; but Iowa isn't the place where an apple-tree takes off its hat and sits down for seventy-five years and makes itself at home. And that is what it will do in Morgan County, West Virginia.

I am printing below a picture of the orchard as we were setting out the trees. It is fairly steep, as you see. In the distance, right over the dash-board of the wagon, there is a white object, like a distant snow-drift. That is an old apple-tree, one of about two hundred which were on the place when we got it; and its white appearance is caused by a mass of bloom that made of it a giant nosegay. Uncle Joe Roach was helping us that day, digging holes. He can make any of the young fellows go some at any sort of farm work, notwithstanding that he did a few days' work on this very field just before he went off to the war in 1861. And to a man under fifty, who looks behind him once in a while to see if the Thing following is not Old Age, Uncle Joe Roach is an embodied hope, he is so rugged and sturdy.

If he reads this, I know he will forgive my speaking right out about him in this way. The lesson of a rugged old age, and the cheer it should bring to thousands of men and women who look back once in a while to see what the Thing is which they suspect to be tagging them, should not be spoiled through any false delicacy.

But all this is partially aside from the point. The point is that Uncle Joe Roach says that that apple-tree which shows in the picture so white with bloom was on the place and a good chunk of a tree in '61. I hope to fix it up and maybe pick apples from it when I am as young as he is now. In '61 the writer had not reported for duty in the infantry of war-born babies; and if that same tree had been planted in Colfax Township, in that black glacial drift, it would have been dead years ago.

There are several of these old veteran apple-trees on the farm, though most of the old orchard has had to be cut down. Some of them we are cutting back and trying to renew, according to the bulletin on renewing old orchards published by the Ohio Experiment Station, and one or two of them we shall let stand just as they are out of respect to their age and beauty. They stand there veritable giants, green and thrifty, their hoary boles like those of forest oaks. They have never known the taste of lime-sulphur or Bordeaux mixture or miscible oil or arsenate of lead or of any spray or wash. They have just simply settled down and made themselves at home in that slaty hillside, where an Iowa farmer would heave a sigh of pity for the man who had to make a living out of such soil.

And now I am going to issue a challenge to the world. I am going to claim the ownership to the biggest and oldest pear-tree in the world. It stands just around the hill from the bloomy apple-tree, within thirty yards of the house we shall build next summer. Nobody knows how old it is. Uncle Joe Roach says that when he was working there in '61 it was, for all he can see, as big as it is now. It hasn't a trace of blight. Every limb is green with foliage now and it casts a shade like a hard maple's.

In 1756 Braddock and his army poured over into this valley at Rock Gap and marched down across the farm to their ruin and defeat at Fort Duquesne. Washington surveyed the route. I have no doubt that they drank from the spring that is destined to cool our dairy, and which bubbles out boldly about seventy-five gallons a minute, and fifty-three degrees in temperature, winter and summer, every minute of the time—has done so for ages before either Braddock or Wash-

ington was born and will do so—seventy-five gallons to the minute, fifty-three degrees—for ages yet to come; and I shouldn't wonder if Washington tried to tell him then, before they got across the Potomac, that it would be just as well to play less music and have more scouts out. And Braddock, being a man who knew it all, scorned Washington's advice and rode on along at the bottom of the slope where the orchard is now.

Whether the old pear-tree was there or not, no one can say; but if you will look at its picture which is published as an evidence of good faith, you will find it easy to agree with me that it may have been. Six feet from the ground it is nine feet in circumference. It has lost a few limbs and, having no care, these dead spots have rotted into hollow places. In these a pair of flying squirrels have made their home, and we find ourselves in a fix a good deal like the historic dilemma of the Emperor Charles V., when he found a bird's nest in the tent in which he had been living. He ordered the tent left standing and I believe he left a sentry to guard the nest until the young birds should take flight.

We have to dig the decayed wood from the Sacred Pear-Tree, and then we have to cement the hollows up, in order that its life may be saved. What is the ethics of this matter? Are we justified in cementing the little flying squirrels into their holes to die horrible deaths? Are we justified in suffering this noble tree to be endangered by decay on account of a family of flying squirrels? Which life is the more precious?

If we can only catch the squirrels away from home some day, we'll cut the Gordian knot by saving all of them!

I don't believe a pear-tree could achieve a girth of nine feet in less than well toward a hundred and fifty years. And here is a thought for the orchardist: Why is it that the improved pears, the Bartletts and Seckels and the rest, are so prone to the diseases and pests that make pear-growing so uncertain, while this old seedling—as I suppose it is—has seen generations of men come

and go like the seasons, and stands to-day green and hearty, without a spot of disease, except the honorable scars just mentioned, bearing pears which in my opinion beat Kieffers all hollow? I give it up. And if any of you folks desire to compete for the pear-tree championship, please enter your trees, remembering that you will have to beat one nine feet in circumference, six feet from the ground. Come one, come all! We shall claim the biggest pear-tree in the world until the honor is stripped from us.

And this is one of the reasons for planting two thousand hopes in the form of trees in West Virginia. If we were still in Colfax Township, we should work out a rotation which would give us seventy-five bushels of corn to the acre every three or four years. And that is the moral of this preachment. When you move to a new locality, don't try to carry the climate and soil with you; but adapt yourselves to the climate and soil—and the community, too—of the new place. In all probability you will find it quite as good as the one you left, if you walk humbly and learn. There are plenty of good reasons for moving—cheap lands, climate adapted to some delicate member of the family, schools, accessibility to great cities—a thousand things. But the man who moves passes a critical stage in his life; for he tests his adaptability. Nobody can escape this, nor quite avoid mistakes. But this we can do: We can plant our hopes in soil that is congenial to them, and shun the error of trying to import corn culture into Manitoba, or—I was going to say peach-growing into

Iowa; but that might offend some of those peach-growers in south of Council Bluffs.

But you know what I mean.

* * *

Do you remember that we invited letters from the nation at large about this much-discussed matter of restoring run-down farms? Well, we got them! From Kansas, Illinois, Wisconsin, Alabama, Kentucky, Indiana, Ohio, West Virginia, Virginia, Pennsylvania, Maryland, New York and New England—all of them fact stories, vastly more exciting to us, at least, than fiction.

And they contain the whole gospel of successful farming. They mean as much to the corn belt or irrigation-project farmer or the dry-farming brethren as to the man whose farm is already ruined. For they tell how farms are run down so they have to be abandoned. We are pleased clear down to the ground at the response to our request. All the professors of all the experiment stations could not have done so well for us; for this is a series of reports from the firing line, where people have to make good or go broke. They will begin in the FARM AND FIRESIDE right soon, now.

Robert Quick

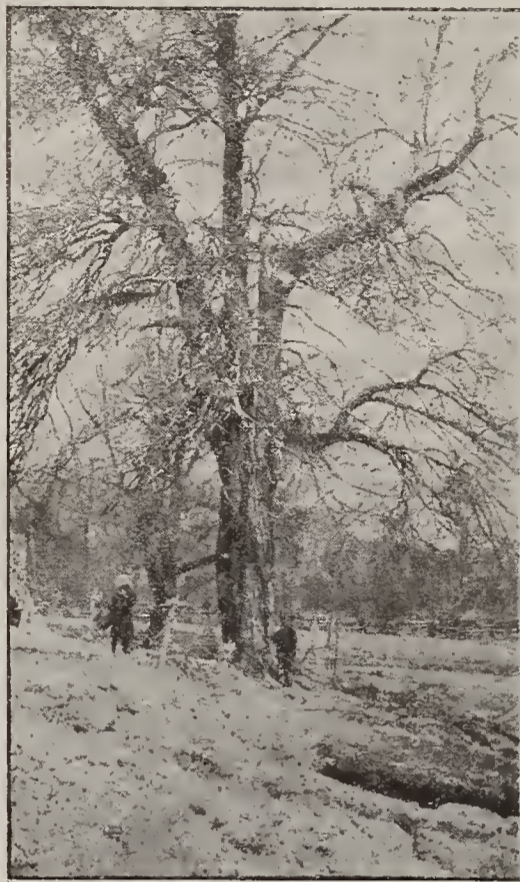

The Pre-Revolutionary Pear-Tree



Orcharding at an Angle

FARM AND FIRESIDE

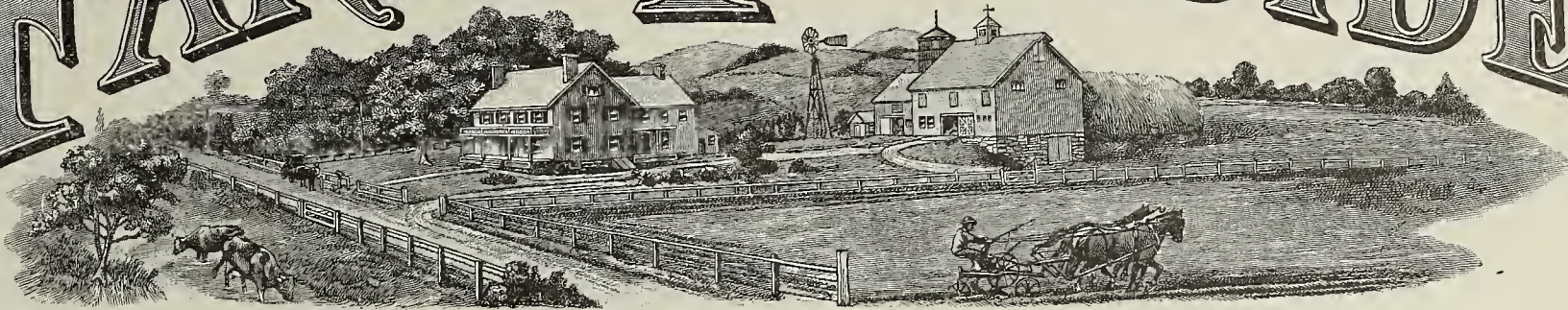

Vol. XXXIII. No. 17

Springfield, Ohio, June 10, 1910

PUBLISHED
SEMI-MONTHLY

Conservation and the Farmer

By Thomas R. Shipp

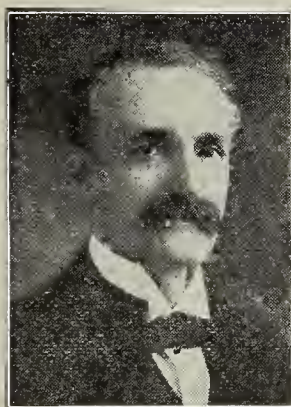

Gifford Pinchot

National Conservation Association, Colorado Building, Washington, D. C.

EDITOR.

Every good citizen is interested in conservation. The farmer ought to be more interested than any one else. In this article Thomas R. Shipp, Secretary of the National Conservation Association, tells why. The association is the representative organization of the friends of the conservation movement. Mr. Gifford Pinchot, former chief of the Forest Service, is its president. By the authorization of Mr. Shipp we append the association's form of application for membership. If you are interested, address Mr. Shipp, care of the Na-

ductive and his profits from it constantly greater. For upon the attainment of this sought-for condition, more than upon any other factor, depends the future prosperity of the land.

It is evident that fullest success in national development must involve the entire utilization of the natural resources of the earth and the complete enjoyment by the people of the resulting wealth. Moreover, since our scientists are predicting an almost limitless future for the human race, these results should be aimed at with grave consideration for the requirements of succeeding generations. Regarding our natural resources as an inheritance and a possession in trust, it becomes a national duty, whilst using them to the best advantage to ourselves, to transmit them to our successors unimpaired, if not improved. By intelligent cooperation with Nature, both these objects may be attained.

The policy of conserving the natural resources of the country is a policy of utilization, a policy of development. It does not mean restriction in use, but it does mean restriction in waste. There are two kinds of waste of our natural resources—waste by using them carelessly and waste by not using them at all. Thus there is waste of productiveness when we permit floods to wash the fertile top soil away into the sea. There is waste when we allow the power which is latent in our rivers and streams to go undeveloped and when river channels are allowed to become blocked and unfit for navigation. There is

as great as those of irrigation, has not yet been systematically employed, but it will shortly be taken up and widely prosecuted by the government. Both these utilities, of such vital importance to the farmer, are dependent for their success upon proper regulation and conservation of water-flow.

The preservation and development of our forest resources concern our agricultural population for other reasons. The improvement of the country's waterways is a factor of ever-increasing importance to the farmer. His reasonable demand for greater profits must seek a response in cheaper transportation for his products, which can be secured only by the development of our inland waterways. Then, the employment of water-power on the farm offers tremendous possibilities. Again, the product of the forest is so highly useful on the farm that a farm without a wood-lot is at a distinct disadvantage as compared with the farm which has one. Without the resources of the forest, the farmer would have to buy all his fuel at high rates, whilst the substitutes for wood that he would be forced to employ in fencing and building would all command prices enhanced by the ever-increasing demand for them.

Although the consequences of the depletion of our mineral resources would fall most immediately and heavily upon our mechanical industries, the ultimate effect of their scarcity could not fail to be severely felt by the farmer. In fact, so closely correlated are our business and social interests that no considerable portion of our national community can be benefited or injured without exerting a reflex influence upon every other portion.

Enough has been said to indicate that conservation holds greater benefit for the farmer than for any other single class of citizenship in America. Therefore, it devolves upon the farmer to lend his effective influence to the furtherance of the conservation movement. This means he should support a conservative governmental forest policy; urge the promotion of reclamation and the better regulation of the mining industry; encourage the improvement of our internal waterways for navigation and for power, and stand for the best use of the public domain for the benefit of all the people.

Very well. But how can he do these things? That is the very question asked not by the farmer alone, but by men in every industry and profession that led to the establishment of the National Conservation Association. The conservation movement had been accepted by the people, but the individual citizen, as an individual, had no part in it. And, believing in it he, naturally, wanted to be a part of it. So, last

July, friends of the movement joined together in a national body of individual citizens, banded together in an efficient organization for the purpose of helping put the principles of conservation into practical effect. This organization is the National Conservation Association, the central body of the conservation movement in the United States. The American farmer, wielding greater and greater influence in national affairs, is needed in its work, and he needs its national influence in the work he is trying to do. With his support, its power for national good is without end.

At the request of the editor of FARM AND FIRESIDE the following statement was prepared by Mr. Pinchot:

With the farmer, conservation is an intensely practical question. The chief of our material resources is the land itself. Its area is fixed, but its productivity may be greatly increased. Conservation affects every citizen in every walk of life, but it touches no man more closely than it does the farmer. No man is more directly dependent upon our natural resources than he is. Therefore, the farmer should have, and he has, a vital interest in the conservation movement. It is this movement which the National Conservation Association is trying to advance. It is fighting for the development of our resources, the well being of our children and the rights of the plain people. I believe there is no better medium through which the farmer can unite in effective work for his own and the public welfare than through the National Conservation Association. In behalf of the Association, I ask for his membership and his help in the work the Association is trying to do.

Gifford Pinchot

THE conservation of the country's natural resources is a question of vital concern to every American citizen. For it is of equal interest to producer and consumer, to laborer and to capitalist that the sources of production be preserved.

At the now historic conference at the White House in 1908, at which governors from states north, south, east and west agreed with the President and national leaders that we had come to "the parting of the ways" and that there was immediate need of steps for conserving the resources the nation had left, practically every American industry was represented. But no man was more vitally interested in the conference than the American farmer.

Was it not Horace Greeley who marked the distinction between the "farmer" and the "agriculturist" by saying that the farmer made his money on his farm and spent it in the city, while the agriculturist made his money in the city and spent it on his farm? With that distinction I use the word "farmer." I like it better, anyhow.

So the farmers of the country, more than any other one class of producers, are concerned in the conservation movement. For in no other single industry are so many different phases of conservation included as are included under farming. Of course, it can easily be shown that all classes of industries are vitally interested in the saving of the country's natural wealth. But to no other industry is the conservation interest so varied as to the farming industry. Different industries are affected by this or that phase of conservation, but the farmer, in greater or less degree, is affected by every phase of conservation. For the farm is the agency through which the natural wealth of the land is chiefly developed.

If the wastefulness which has prevailed be continued, its consequences will fall first and most heavily upon the farmer. Furthermore, the welfare of posterity should interest the farmer most closely, for in his case, more perhaps than in any other, it is peculiarly true that his children should follow in his footsteps. I say "should" follow. They don't always do it. The conditions under which they will have to make a living, and success or failure will depend largely upon the way in which their fathers performed their duties of trusteeship.

The conscientious possessor of land should consider his tenancy essentially a stewardship. A proper conception of his responsibility will not permit him to transmit it impaired by careless tillage. For instance, no farmer who is true to his trust can view with careless indifference the denudation of forest-clad hills, which he should know will bring on floods which rob the earth of its richest and most necessary elements. Yet wasteful processes have been permitted to go on with little or no check until we find the land in grave danger of growing constantly less equal to the support of our ever-increasing population. With proper handling, it should be more than equal to support it. But the American farmer is awakening to the necessity of changing his methods so that the soil he cultivates shall become with use ever more pro-

waste if coal is consumed, when water-power, which might be used in its stead, is allowed to run neglected and unused. In short, conservation means development without waste. It means use as against abuse. It means development and use that will insure "the greatest good to the greatest number for the longest time."

Waste is a serious thing. For example, waste of water is a menace to our present and our future prosperity. Two chief forms of water waste, besides the waste of water for power and navigation, are found in useless lakes and noxious swamps, both of which are the result of a lack of conservation. The waste entailed by these circumstances is much greater than at first appears. Then there is waste of land. Practically all the cultivable land in this country has been disposed of. Before the close of the present half-century it is estimated that our population will be twice as great as it was at the beginning of the century. In order to find homes for this great addition, a large proportion of whom must depend directly upon the soil, it will be necessary to open extensive new areas to cultivation. In some measure this will very likely be accomplished by re-peopling the abandoned farms of the East with men who will subject them to scientific and intensive methods of culture. But, in the main, we must look for the solution of the problem to the recognition of arid tracts by irrigation and the reclamation of swamp-lands by drainage. Irrigation is only beginning, but it gives promise of splendid utility. Drainage, which involves prospects

To Gifford Pinchot, President
National Conservation Association
Colorado Building, Washington, D. C.

I inclose herewith \$..... in payment of all dues as
..... member of the National Conservation Association
for the year 1910.

Name.....

Address.....

Membership Dues		
Members	\$2	a year
Active Members	\$5	"
Contributing Members	\$25	"
Patrons	\$100	"
Life Membership, \$1000		

Checks should be made payable to the National Conservation Association

Putting the Stream Into Harness

Weir Measurement and Head-Race Construction—By Marshall O. Leighton

THE method of stream measurement described in our previous article (May 10th), while simple and convenient, is not always possible. It requires a long regular stretch of channel. Some of our best power streams have crooked, irregular channels filled with large boulders which make it impossible to measure average depth or speed of current. In such cases it is usually possible to measure with a weir. The weir is simply a small dam usually made of plank placed across a stream so that the water will run over it in a smooth sheet. It need not be placed in the stream at the swift-water stretch where the water-power privilege is supposed to be, but is more properly placed at some point above or not far below, where the channel is more nearly level and where the water runs at only a moderate speed. It is of advantage to select a place where the bottom of the channel is of earth, so that a trench may easily be dug into the banks and along the bottom in which to set the weir so that it will not leak underneath or at the ends.

It will be seen from the illustration that the weir is made of planks and that the central portion is not built up as high as the ends. All the water runs over this central portion, or "notch," note also, that the edges of this "notch," both bottom and sides, are beveled sharp and the level cutting is all on the down-stream side of the weir, so that the up-stream edges are smooth, sharp and clear. The "crest," or bottom edge of the notch, should be perfectly level—the ends should be plumb and all corners square. It is not desirable to have the notch so long that the amount of water in the stream is sufficient to produce only a very thin stream of water when passing over the edge, nor, on the other hand, is it desirable to have the notch so narrow that all the water in the stream cannot pass through it without overflowing the ends of the weir. In other words, the capacity must be made somewhere near the capacity shown in the illustration—that is, so that the water will go over the



Courtesy Barnard and Lees Co., Mobile, Illinois
Locating a Farm Power—Measuring Stream Discharge With a Weir

actual depth of water over the top of the stake. By using that depth in the following table, which has been worked out by experiments, the amount of water passing over the weir can readily be calculated.

Amount of water in cubic feet per second passing over sharp-crested weirs per foot of length:

Depth in Inches	Discharge	Depth in Inches	Discharge	Depth in Inches	Discharge
1	.08	4 3/4	.83	8 1/2	2.00
1 1/4	.11	5	.90	8 3/4	2.09
1 1/2	.15	5 1/4	.97	9	2.18
1 3/4	.19	5 1/2	1.04	9 1/4	2.27
2	.23	5 3/4	1.11	9 1/2	2.36
2 1/4	.27	6	1.19	9 3/4	2.46
2 1/2	.32	6 1/4	1.26	10	2.56
2 3/4	.37	6 1/2	1.34	10 1/4	2.65
3	.42	6 3/4	1.42	10 1/2	2.75
3 1/4	.47	7	1.50	10 3/4	2.85
3 1/2	.53	7 1/4	1.58	11	2.95
3 3/4	.59	7 1/2	1.66	11 1/4	3.05
4	.65	7 3/4	1.74	11 1/2	3.15
4 1/4	.71	8	1.83	11 3/4	3.25
4 1/2	.77	8 1/4	1.92	12	3.36

For an example of the way of using this table, let us assume that our weir is eight feet long and the measurement from the top of the stake shows that the water is eight inches deep. Examination of the table shows that the corresponding discharge is 1.83 cubic feet per second. But this is for one foot of length, and our weir, as above stated, is eight feet long. We will then have to multiply 1.83 by eight, which equals 14.64 cubic feet per second, or, say, fourteen and one half cubic feet. Always multiply the discharge values in the above table by the length of the weir to get the discharge of the given stream.

Suppose that, by the methods described in our previous article, we had found that the river along the given stretch measured had a fall of, say, ten feet and that the discharge was about fourteen and one half cubic feet per second. In order to determine how much horsepower this represents, multiply the flow (fourteen and one half feet per second) by the fall (ten feet) which gives a product of one hundred and forty five. Then divide this result by eleven, which equals about thirteen. This is the horse-

power available. Always multiply the discharge by the fall and divide by eleven to find the number of horse-powers available in the given stream.

It will be appreciated that after a weir like that above described has been established it will be valuable for future use in the measurement of the flow of the stream and it can be maintained for months or years, if desired, and daily readings can be taken of the amount of water flowing in the channel. Such readings are also of great value in determining the amount of water available for irrigation, if the stream happens to be in a land of little rainfall.

From Stream to Power House

We have now considered all the steps necessary to determine whether or not our stretch of stream affords power sufficient to pay for development. Having decided that it does, we will now take up the process of constructing the works. At the outset it should be emphasized that in this, as in all other kinds of construction, it is far better to secure the services of a skilled man. It is true that almost any one of ingenuity and common sense may, after study, build a plant that will serve for all farm purposes, but a skilled man will build a better one, which will probably be cheaper in the end.

Our first task is to provide a conduit to lead the water out of the stream to the water-wheel. This conduit is usually called the head race. The way in which this should be built depends on the local conditions. If the stream runs in the bottom of a glen and the banks rise abruptly from the water's edge, it is generally a good plan to make the head race by digging a ditch of sufficient capacity along this bank, keeping it on a very small grade, of course. In other places, where there are no such banks, it may be necessary to conduct the water in a wooden flume, mounted on a trestle, or part ditch and part flume may serve. The size of the head race and its proper slope depend, of course, on the amount of water necessary. Now our important purpose is to get that water along the head race to the wheel with the least possible loss of fall. Of course, our race must have some slope in order that the water may run in it, but it is generally

better to build the race large so that it will carry the necessary water on a slight slope than to build it small and then give it so much slope that a large part of the head on our wheel is used up. Just what to do requires some study and the process is difficult to explain without covering too much space. The editor of this paper will be pleased to answer inquiries concerning any particular case if the reader will send a full statement of conditions.

Every farmer knows how to dig a trench and how to level it. The easiest method is to dig the trench level and then give it just the slope desired. In the construction of a farm water-power it is not necessary to adopt any refined methods. If, for example, the trench is five hundred feet long and the slope necessary is equal to one inch per hundred feet, then the total slope in the trench from beginning to end will be five inches. Therefore, it will merely be necessary to excavate the lower end of the trench to a point five inches below the level grade and to carry this excavation back to the head of the trench on a uniform grade. It is always necessary to have at least a short piece of flume at the lower end of the trench to carry the water to the turbine. The length and material of this flume depend entirely on local conditions—sometimes it is better to make the flume of concrete.

Presumably, every farmer knows how to build a flume and how to support it on a trestle, and the illustrations here given (Fig. 3) will be sufficiently suggestive. Of course, it is necessary to give slope to the flume even as to the trench and this can readily be done with the carpenter's level and the use of common sense. The flume is at or below ground level where the water enters it and is higher above-ground the farther away from the entrance point it is constructed, the height being planned to fit conditions.

A flume can be built on the shortest possible course from the intake to the outlet over the turbine, but a trench dug in the ground must usually follow the land contours—that is, must follow a line that is practically level wherever

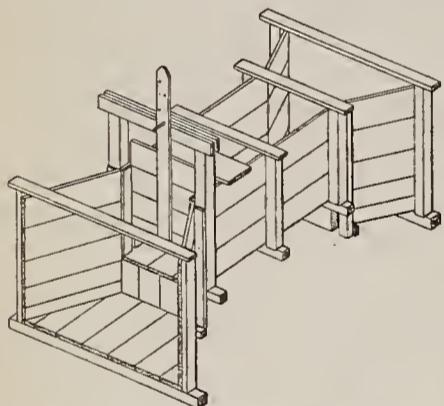

Fig. 1—Details of Small Head-Gate

weir at a comfortable depth and make a smooth apron, or "nappe," as it drops below the weir.

It should be borne in mind that one of the necessary things in connection with the weir measurement is to have the weir create a little pond above like that shown in the illustration, so that the water will not have much speed as it approaches the weir. The whole weir is then packed around the end and bottom with clay or impervious earth so that all the water passing in the stream will flow over the weir notch. The drop of the water below the weir should be at least three times as great as the depth of water passing over the sharp edge. It is far more convenient to make the length of the slot an even number of feet, say eight, ten, twelve or fourteen, because it is easier in the subsequent calculation of flow.

How to Compute the Discharge

Now it will be seen in the illustration that the man is measuring with a square the depth from the surface of the water down to the top of a stake that he has previously driven into the bottom of the stream. And it will be seen along the line (D) that the top of the stake is exactly level with the top of the weir (B). In other words, the man is measuring the depth of the water flowing over the weir. This measurement cannot be made from the sharp edge of the weir itself, because of certain physical reasons that it is not necessary to explain here. Therefore, the best plan is to drive a stake into the bottom somewhat above the weir until the top of the stake is exactly level with the weir crest. The man in the picture is represented as measuring the

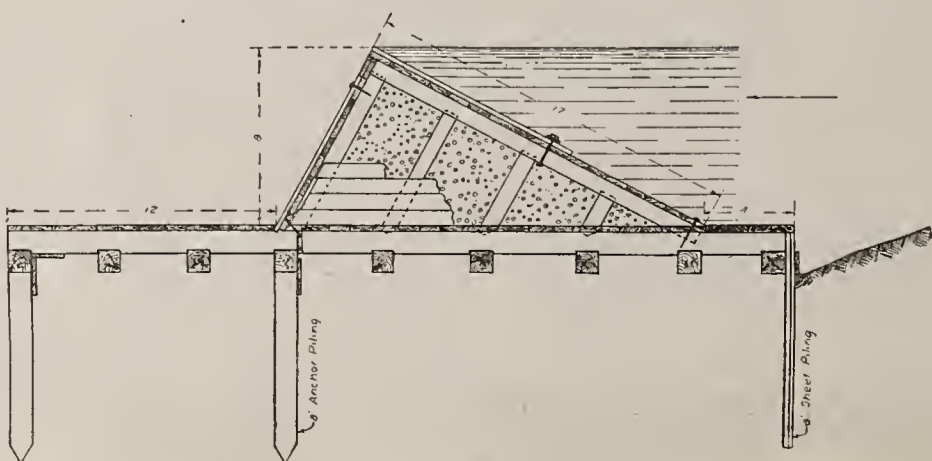

Fig. 2—An Approved Type of Timber Dam

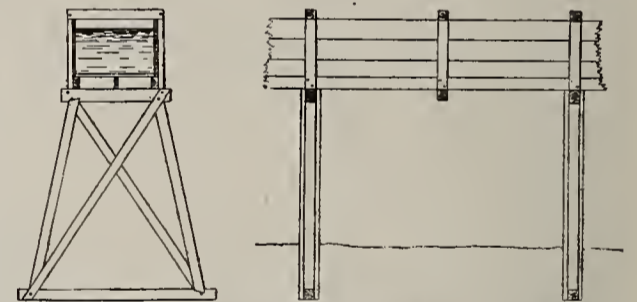

Fig. 3—Cross Section and Elevation of Trestle and Flume

that line leads. There are several ways by which the course of such a trench can be laid out. The simplest is with the straight edge from ten to fifteen feet long with parallel edges, and a carpenter's level. The course should commence at the point at which it is proposed to divert the water from the stream, and a small stake should be driven into the ground there. Common sense will decide for any man how far from the water's edge this starting-point should be made. In some cases it may be necessary to lead the trench into the hill for a short distance in order to get a clearing for the remainder of the trench.

In any event, one end of the straight edge should be placed on top of this stake and the other end carried downstream and moved from side to side on the ground until the rod is level, as shown by the carpenter's level placed on its edge. A small stake should be driven at this point and the process repeated from the second stake and the whole line of levels carried down in this way until the final point is reached. It will be seen that this process is the same as that described in the previous article for finding the fall in the stream, except that, instead of finding the difference in elevation between two points along a definite line, we "feel around" to find a line at which two points are at the same elevation. We will then have a line of stakes in the ground denoting an approximately level course. And along this line the trench must be dug to a depth suitable for diverting the water from the stream.

Of course, in excavating this trench, the entrance to the stream should not be

[CONCLUDED ON PAGE 5]

Around the Farm

Topics of Timely Interest to Progressive Farmers

Cow-Peas for Meager Soils

THE cow-pea is not only the greatest orchard crop grown in the Ohio valley, but it is one of the big factors in the problem of building up much-worn soils. It does not follow that it is always the best crop to grow in the orchard under all circumstances, nor does it give us the complete solution of the soil-building problem, but it fills the bill in more places than does any other plant.

Being a legume, it augments the available supply of nitrogen in the soil, thus enriching it and making it more porous and mellow. It may be sown July 1st with us in Kentucky, so does not stand in the way of clean cultivation during the spring. A hard, lumpy, crusty soil does not respond well to cultivation, but a single crop of cow-peas will mellow it to a great extent. The more porous and spongy the land, due to the growth of cow-peas, the better it will withstand drought. Cow-peas add humus to the soil, which enhances its water-holding capacity. The fact that the soil becomes more porous also makes it possible to form a better dust mulch by cultivating to check evaporation.

Where cow-peas are to be pastured by hogs, varieties that produce many seed are desirable. Among the best early varieties for this purpose are Whippoorwill and New Era. Some of the late sorts also make many seed. It is well to ascertain what varieties seed well in a given locality and select these if they are to be used as feed. For hay or as a soiling crop, the seed of the black or gray varieties should be planted, as they make a large growth of vine and a fair amount of seed.

I have tried several methods of planting the cow-pea, such as broadcasting and plowing them in, putting them in with a grain-drill, with each alternate hole stopped so as not to get them too thick, and with a one-horse corn-drill having a plate with small holes made especially for peas and beans. This last method gives much the best results. With the corn-drill the seed are put in rows, thirty inches apart for the bush sorts and thirty-six inches for the heavy vining sorts. I use one bushel to the acre with the small-seeded varieties, and with the large-seeded varieties one and one half bushels.

Clean culture is given the soil from early spring until the seed are planted. Just as the seed are coming up the spike-toothed harrow is started. By the time the peas are five or six inches tall we have been over them twice. Sometimes it seems as though we are tearing them all out by the roots, but we just keep on stirring with the harrow and the peas just grow that much faster. The peas are cultivated until the vines meet between the rows, to keep down weed growth as much as anything else. When the growth of vine is heavy enough to shade the ground all over, no weeds will be able to grow and mature seed.

We do not cut cow-peas for hay, as we prefer feeding them in the field or plowing them under, peas, vines and all. The field of peas shown in the picture was pastured with hogs, which were turned on when the crop was about half ripened. The hogs ate the peas, but paid no attention to the vines or leaves, which they tramped under foot. When these are all turned under, with the manure left by the hogs, the soil is left full of decaying vegetable matter, which puts it in fine condition for corn or potatoes to be followed by wheat.

On this field, ten years ago, we could produce only thirty-five bushels of corn or about eight bushels of wheat; now it will yield one hundred bushels of corn and twenty-five of wheat. With a rotation of wheat, cow-peas, corn and potatoes, the wheat being sometimes seeded to clover for a crop of hay for the milch-cows, we are building up our soil and at the same time producing paying crops.

J. W. GRIFFIN.

Patent Menaces

IN ITS effort to protect the innocent public against the insidious effects of preparations containing drugs injurious to health, the United States Department of Agriculture has issued another Farmers' Bulletin treating on the subject.

Farmers' Bulletin 377, The Harmfulness of Headache Mixtures, was issued in September, 1909, and seventy thousand copies have been distributed; now Farmers' Bulletin No. 393, Habit-Forming Agents: Their Indiscriminate

Sale and Use a Menace to the Public Welfare, giving the results of recent investigations by the department, has just been issued as a warning to mothers, invalids and users of medicated soft drinks, of the dangerous contents of many of the infant syrups, so-called remedies, and soft drinks containing cocaine, etc.

It is almost unbelievable, but several mixtures containing cocaine have been found and their names published, together with a list of "remedies" intended for infants and containing morphine, codeine, opium, cannabis indica, heroin, which are widely advertised, and are accompanied by the assertion that they "contain nothing injurious to the youngest babe" and that "mothers need not fear giving them, as no bad effects come from their continued use," while as a matter of fact



The Cow-Pea Rows at Harvest-Time

numerous instances are on record of babies being put to sleep never to wake again or, where they did not succumb, the more serious effect of infant drug addiction was produced.

The bulletin contains a list with a photograph of the "original packages" of some of the soft drinks containing caffeine and cola leaf extracts, to which it is not uncommon to find persons addicted. It also mentions some of the harmful nostrums advertised as cures for asthma, catarrh, cold, coughs, consumption, epilepsy and the tobacco habit, and states that some physicians in their prescriptions in treating these diseases and in attempting to cure the "drug habit" itself often prescribed the very remedies that have produced the conditions which it is proposed to relieve.

This bulletin can be secured by writing to the Secretary of Agriculture, Washington, District of Columbia, to any senator, representative or delegate in Congress.

A Flying Start on Haying

AS IN any and all lines of labor, hay-harvesting demands special and timely preparations if it is to be successfully carried on; but these preparations generally need to be made at a season when the farmer is so busy that he neglects or puts them off till the very day he ought to begin the rush work. Then there is a loss of time which might have been avoided by judicious management.

Right now is the very time to make all preparations for handling the hay crop. Some day, when you have an hour or two to spare, make a thorough inspection of every tool and piece of machinery to be used in the hay-field. Jot down in a note-book every item of repairs needed: Sickle-sections, burs, bolts and all missing parts of machinery. The next time you go to town, buy or order these repairs, together with a good supply of first-class machine-oil (poor oil is dear at any price).

In fact, it is advisable to lay in a supply of extras, to provide for any accidents that may occur in the field. This is especially true of sickle-sections, rake-teeth, stacker-ropes and pulleys. Stopping the team, and sometimes the whole haying crew, till you drive to town for repairs, incurs a great expense through loss of time, besides leaving the hay in the swath too long, causing over-curing or damage by a soaking rain. And in order to further minimize the time lost by

repairing breakage, these repairs should be carried right along with the haying outfit in the field.

An important accessory to the outfit is a canvas stack-cover, to leave on the open stack at night or when a shower is approaching. This makes it unnecessary to work till dark to top out a stack if the weather is threatening, and insures a fine grade of hay. Where the stack is left open and uncovered, even though the rain wet but a short distance down, the damp hay on the surface never will make ideal feed. The cost of these covers prevents many farmers from owning them, but one should consider that, with proper care, the canvas lasts for years and years, and will save enough in time, labor and roughage to pay for itself manifold. The better grades of canvas are the most eco-

it will be impossible to thoroughly eradicate them. While it is not necessary that the first plowing be deep, it is essential that the soil be thoroughly stirred in order to destroy all the weeds. I have found it a good plan to use a cultivator with small shovels for the first plowing.

I believe it is most satisfactory to have fenders for the cultivator during the first plowing. The fenders prevent the soil from falling on the young corn, saves the time of the farmer who must stop and stoop to uncover the corn, and also permit the very close cultivation of the corn that is so essential for the destruction of all weeds and grass.

I never could do a good job at first plowing by hurrying the team. I always let them take a slow, steady walk, for I feel I am making time by going slow and doing a good job. The fellow who rushes his team across the field will leave some corn covered, some grass and weeds, and unstirred soil near many hills.

W. D. NEALE.

Putting the Stream Into Harness

[CONTINUED FROM PAGE 4]

dug until the whole trench is finished, and even before this is done, a headgate should be constructed. In Fig. 1 the whole box-like structure of this is shown, ready to be installed at the end of the trench or flume. Its sides are so made that the earth can be tightly packed around it.

In either flume or trench, there should be a headgate and also a gate at the lower end. There should also be notches or weirs along the course of the trench or flume so that the water in the conduit will flow out over the sides wherever it rises above a certain height. Two gates, at least, are desirable, for if, perchance, the headgate should be accidentally broken down, the lower gate near the entrance to the turbine would be needed to shut the water out from the wheel when the power is not in use. As structures of this kind are inexpensive, it would be poor economy to omit them.

It is usually necessary to place some kind of obstruction, like a dam or weir, in a stream in order to pond up the water and thereby help to direct its course into the ditch or flume. The character of such a dam depends entirely on local conditions, and here again is an opportunity to use common sense. If it be found, for example, that the flow of water in the stream is far greater than will ever be needed to operate the power, then it may not be necessary even to place any dam in the stream, or the dam may consist merely of a pile of rocks dumped into the channel, that will let the water flow between or over them and yet hold back sufficient water to form a small pond. In many cases, however, especially in small powers, there comes a time during the low-water season when all the water in the stream is needed. Then it will be necessary to construct a tight dam, and if the stream channel is of rock, it will usually be advisable to build a masonry dam, which is always expensive, although it is so permanent that, in the long run, it will pay for itself. If, however, the channel is of earth, it is usually considered economical to build a temporary structure of timber crib or sheet piling. A dam of this kind is shown in Fig. 2. The timber crib dam consists of a timber grill into which rocks are set in order to give the structure stability. The sloping sides are then covered with two courses of plank with broken joints, and an extra course is usually necessary at the lower face of the dam to serve as an apron, so that the water in running over the dam will be carried well beyond the toe of the structure and will, therefore, not scour out underneath and impair the foundations. Of course, all dam structures must be erected on suitable foundations. The one in Fig. 3 is founded on piles and is designed for an earth channel. In the case of rock channels, holes should be drilled into the ledge and the lower timbers of the dam secured thereto with heavy iron bolts at least five eighths of an inch thick.

If conditions are favorable, it may be found a good plan to carry the water from the head of the fall to the powerhouse in a large pipe instead of in an open ditch or flume. The efficiency of the pipe method is practically the same as the next.

Our next article will take up the power-house and its machinery, and describe the various farm uses to which the power may be applied.

Corn-Plowing Pointers

WEEDS being your earliest and most formidable enemies, cultivate deep and close to the corn the first time; not quite so deep, and a little farther away, the second time, for the roots must not be molested. They are Nature's channels through which all nourishment reaches the plant.

Practise shallow cultivation every plowing after the second one—just enough to maintain a dust mulch and keep down the weeds. Deep plowing injures the roots, retards the growth of the plant and allows the ground to dry out farther down than it should. These conditions, besides cutting down the yield, leave the stalk with very little support from the roots, rendering it more easily blown over and damaged or ruined.

Won't the sun dry up the soil around the stalk and extract all the sap from the life-giving corn-roots quick enough, without your scraping the dirt from between the rows and hilling it up against the corn when you are laying it by? Leave the earth slightly elevated along the row, but don't try to make a sweet-potato ridge out of it.

M. A. C.

THERE is no cultivation of the corn so important as the first. A poor first plowing invariably means a foul crop, for the grass and weeds get such a start

Gardening

By T. Greiner



In the Vineyards and Orchards of the Northwest

are unequalled opportunities to make money in intensive farming, fruit-growing, vegetable-raising, dairying, poultry and stock-raising. Washington, for instance, is a great state of snow-capped peaks, noble forests, tumbling rivers, fertile valleys, wave-lapped seashore. Incomparable climate. Immense water power; vast areas of valuable timber; a fishing industry that rivals the world. Intensive irrigated farming and fruit-growing in a high degree of development. The Yakima, Kittitas, Walla Walla, Spokane and Lewiston-Clarkston Valleys, the Columbia River Basin, the Puget Sound Country, Gray's Harbor, Willapa Harbor, the Inland Empire Region, the Big Bend and Palouse Country present ideal conditions. The Washington fruit lands grow prize-winning fruits and berries. The Washington grainfields yield bountifully of the best grades of product. You ought to learn more about the Northwest and its possibilities. You ought to see it. Write tonight for information. Say what state interests you most.

The Scenic Highway Through the Land of Fortune

Northern Pacific Railway

L. J. Bricker, General Immigration Agt., Dept. 306, St. Paul, Minn.
A. M. CLELAND, General Passenger Agent, ST. PAUL



Settling the Asparagus-Beetle

A PENNSYLVANIA reader asks for advice in regard to protecting his asparagus from the asparagus-beetle which is bound to feed on it. This insect usually begins business as a producer of eggs as soon as the weather gets a little warm in spring. We often find young shoots only a few inches high already covered with the small dark colored eggs. The problem is simple at this time. Cut close, leaving no stalk to grow up until after the cutting season. Of course, there can then be no propagation of the insect. But after July, when we let the shoots grow, the leaves are often riddled and the stems left bare. This is a case for the use of strong poisons, especially arsenate of lead or, in its absence, Paris green. You could blow poisonous dust over the foliage when wet with dew, but I prefer to apply arsenate (or Paris green) in spray form. We can use them with Bordeaux mixture or with the lime-sulphur solution. The beetles cannot stand this treatment.

Among other remedies often recommended is dusting the wet plants with air-slaked lime. In my experience it has not proven absolutely reliable. Neither am I prepared to say that an application of buhach (California insect-powder), either in dust form or in water, would kill the beetles. Kerosene emulsion may be tried. We have a number of catbirds on the premises. This bird has the reputation of being fond of the asparagus-beetle. In our case they have been guilty of sins both of omission and commission. They have left the beetles untouched and taken things we did not care to have them take.

Pumpkins and Squashes for Show

J. F. H., an Ohio reader, is interested in raising mammoth pumpkins and squashes for exhibition purposes. First of all, get seed of the mammoth variety or varieties of these vegetables. They are known under various names as "Mammoth pumpkin" and "mammoth squash." Then make the hills far enough apart, say twelve feet each way. For each hill throw out the soil to the depth of a foot or more and three to four feet in diameter. Mix this soil thoroughly with fine manure and a quantity of hen-manure. Be sure the mixing is well done. A small quantity of any good complete fertilizer, such as is known as special potato or vegetable manure, for instance, may be added although this is not an indispensable condition of success. When all this is thoroughly mixed, fill the hole up with the mixture and plant the seed. Leave only one or two plants to the hill, and only the first good fruit to each vine. Hoe often and deeply. That is about all that can be done, and that is necessary to do to accomplish what you are after.

Queries About Potatoes

A Missouri lady asks the old, old question of the influence of the moon on yield of potatoes. Also, will small potatoes bring small potatoes? And how many eyes should be planted to the hill?

Questions about the moon influence were asked quite frequently some years ago, but people now have got nearly over that notion, for it is nothing more than a notion. Small potatoes may yield very big ones. We often use small potatoes for planting when others are scarce, and expect good crops of average-sized tubers. A medium-sized potato, however, or one just below medium is usually considered the best for planting. I lay more stress on the sound condition than on mere size and prefer a very small tuber that is in a dormant state, sound and plump, to a large one that has been weakened by sprouting and shriveling. I invariably plant a small potato whole, and cut the larger ones in two, three or four pieces, according to size. Many growers practise planting single-eye pieces, but I want a fairly good-sized piece, having at least two good eyes and possibly up to four or five.

Dry Rot in Seed-Potatoes

To a Kentucky reader I would say, when you cut seed-potatoes and come across one that is black on the inside, throw it away. Never plant anything that looks in any way suspicious. Disease makes its appearance often enough even without propagating infection on purpose.

Gardens for Public Dependents

THE "back to the land" movement is becoming more and more universal every day, and will continue, for it offers an occupation which is open to all—young or old, weak or strong, sick or well. Institutions of all kinds, such as asylums, poor-houses, convalescent homes, reformatories, penitentiaries, etc., have taken up gardening, all with unexpected success. The most effective work has been done by individual gardening. In time it ought to become a most important part of almost every institution, especially those for children. It provides not only a means of support to the institution itself, but it has a most beneficial effect on the workers. The very fact that the garden he works can be called "my own" creates in the cultivator a feeling of independence and responsibility that nothing else could do.

Some institutions hesitate, saying they have not enough land, or that it is not fertile enough. A very small piece of ground is all that is needed, and manure or household garbage and night soil will supply the fertility. The main thing is to get a start; for once a beginning is made the inmates themselves will carry the work along. Some of them are sure to have been brought up on farms, and each is willing to help the others.

Every farmer realizes the scarcity of proper farm help. Intelligent cultivation taught in our private and state institutions would train up a competent supply. To those interested in this work the articles in "The Survey" of February 19th and March 19th, on "Individual Gardens in Institutions," will be especially interesting. Reprints will be sent on application to the undersigned. (Please inclose stamps.)

BOLTON HALL,
56 Pine Street, New York City.

Safe Methods With Celery

I am frequently asked whether there are any new developments in the method of celery-growing introduced ten or more years ago as "the new celery culture" and whether I now practise it. I do not. It is true that we can grow White Plume or perhaps other self-blanching sorts by a system of close planting, in beds of any size, the plants standing ten inches apart one way by six or seven the other. If the land is very rich and you can supply an abundance of water during the season of most rapid growth, you could produce an immense quantity of what might go for celery, on a small area. I have at times grown such stuff, and sold it, too. It will sell when nothing better is offered. When the conditions are not all favorable, however, we do not expect much of anything worth having. At any rate, White Plume is never first class and we can grow other and better celery by other and safer methods.

Blanching with boards will give us fairly good celery, but earth blanching gives better quality with any variety than does blanching by boards. I only use the board method for the very earliest. At this writing I have just set out a quantity of plants, taken directly out of a seed-flat (about six hundred to the flat twelve by eighteen inches) and not very large. But they seem to have taken hold of the soil already and stand like soldiers in double column. The two rows are ten inches apart, and will be blanched by means of boards.

Cucumber-Planting Time

No excuse for neglecting to plant cucumbers, or, as they are called in many localities, "pickles." In a favorable season we may plant as early as May 15th, even in the Northern states (and earlier south); but if we neglect it then or don't have the chance, the latter part of May and nearly the entire month of June will do. Sometimes the later plantings will give the best crop. If soil is rich, light dressings of fertilizer worked well into the soil in each hill will help; if poor, better dig a lot of old manure into each hill, mixing it as thoroughly as you can with the soil. Then plant the seed in this.

Ten or a dozen seeds to the hill is about the right number, and they should be put in about an inch deep.

For the Flea Beetle

Beetle dozers, something on the plan of hopper dozers, are to be tried on Long Island for the flea beetle on potato-vines. Thorough spraying with dilute lime-sulphur solution or perhaps Bordeaux mixture, in either case combined with arsenate of lead, has always seemed to give me complete control of the pest, and, I believe, will do the work more thoroughly and more conveniently.

Tell Your Neighbors

To introduce FARM AND FIRESIDE to your neighbors who are not now subscribers, the editors make you this unusual offer: Get two people each to give you 50 cents for a year's subscription to FARM AND FIRESIDE. Send us the one dollar, and in return for the favor we will send you FARM AND FIRESIDE for one full year without cost after your present subscription expires. (If you are not now a subscriber, your own subscription will be entered for one year without cost.)

FARM AND FIRESIDE, Springfield, O.

DON'T DIG WHEN IT'S QUICKER TO BORE

Standard Post-Hole Auger is the tool you need for fence work, tree planting, post-holes, etc., etc. Bore like a drill; dump like a shovel. Get Our Free Catalogue 26

STANDARD EARTH AUGER CO. 1128 - 1134 Newport Ave., Chicago, Ill.

Sears Model "L" \$495.00 Complete

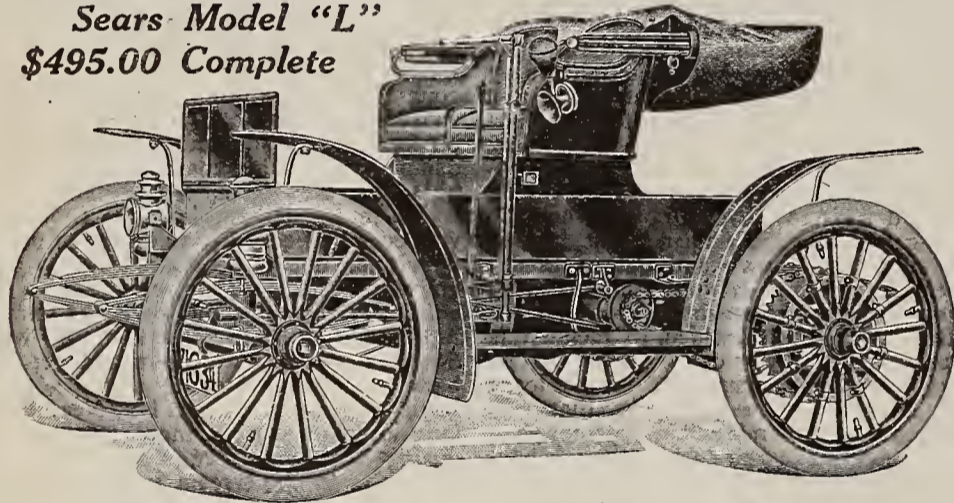

Automobiles

We build them We guarantee them We sell them to you direct from our factory

Real Inside Prices

OUR new Automobile Catalog quotes THE ONLY REAL INSIDE PRICES ON AUTOMOBILES. In this catalog we show automobiles for \$370.00 and up, six different models, all built by us in our own automobile factory. When you buy a SEARS you get it direct from our big Chicago factory at the factory price.

With our new Automobile Catalog we will send you our Booklet of Testimonials showing pictures of customers using Sears cars in every part of the United States, with letters from them telling their experiences.

If you are interested in an automobile of any kind, write today for our Sears Automobile Catalog No. 72F41

Sears, Roebuck & Co. Chicago

Fruit-Growing—By Samuel B. Green

Why We Grow Cover Crops

COVER crops is a term used in connection with the growing of crops in orchards. In a general way, the best fruit-growers are a unit in believing in the importance of clean cultivation for orchards. However, as we have frequently noted, this is often impractical on steep hillsides that are liable to wash badly. Clean cultivation also leads finally to a poor condition of the soil, which can only be fully remedied by the addition of humus. This humus may be added by the application of coarse stable litter or other organic matter directly to the land. In this case the humus is confined almost entirely to the few upper inches and is not distributed throughout the soil as it is by the growth of clover or similar crops. The decaying roots of a cover crop leave humus both in the subsoil and in the surface soil, thus rendering the whole mass more porous.

Still other advantages of cover crops are: (a) They protect the soil to some extent from deep and sudden freezing and thawing; (b) they prevent the snow from blowing away in the winter; (c) such cover crops as clover and peas not only improve the physical conditions of soils on which they grow, but actually leave them richer in nitrogen. On this account, plants of this class are especially desirable for orchards. (d) They are sometimes helpful in checking the production of the wood in late summer by using up some of the plant-food and moisture in the soil. This checking of late growth in the fall encourages the early ripening of the wood, thus leaving the tree in best shape to stand the winter.

How to combine the advantages of cover crops and cultivation is often an important question for orchardists. In many fruit sections this may be done by cultivating the soil during the summer and seeding down to some cover crop in the late summer or early autumn. This may be a crop that will kill out in winter or that will live over and be allowed to grow on the land until late in spring, when it is turned under. Occasionally it may be a good plan to seed an orchard down to clover for a year or two in order to increase the humus in the soil; as, for instance, in the case of soils on steep hillsides where the humus is nearly exhausted. For this purpose the land should preferably be plowed in late autumn and the clover-seed sown in early spring without any nurse crop.

Among the best cover crops are the following:

(a) Peach-growers of Michigan and apple-growers and nurserymen of Minnesota use oats in their orchards, sown from the first to the middle of August, to protect the roots from severe freezing. Such a cover holds the leaves in autumn and the snows in winter, thus preventing frequent freezing and thawing, as well as deep freezing of the ground.

(b) Crimson clover is an excellent cover crop for parts of New York state and south to Alabama. It should be sown in late summer or early autumn in New York, but later in Alabama, where it grows all winter.

(c) Buckwheat is a good cover crop for steep slopes or other places where it may be desirable to use a cover crop in summer. It shades the ground and aids in preventing the soil from drying out. (d) Vetches and cow-peas may sometimes be used to advantage, sown in early spring. The cow-pea is the great cover crop of the Southern states.

(e) Soy beans make a good cover crop and are sown in midsummer in rows.

(f) The velvet bean and beggar weed are great cover crops for the extreme Southern states.

(g) Mammoth clover and alfalfa may be used as cover crops if plowed under the second or third year. They should be sown in orchards without a nurse crop in the early spring, a space four feet wide sometimes being left for cultivation by the side of the rows of trees.

Spray the Strawberries for Rust

S. H., Minnesota—In order to prevent rust on strawberries the plants should be vigorous and strong when planted, and on the first indication of the red spots on the leaves, which early show the rust, the plants should be sprayed. For this purpose, nothing known is better than Bordeaux mixture of the ordinary strength, say four pounds of sulphate of copper, five pounds of lime and fifty gal-

lons of water. This should be applied at intervals of about two weeks, until the plants are fully grown. The following year they should be sprayed again, as soon as they are started, which should be repeated soon after the fruit sets. This will generally prevent the appearance of the rust.

This disease appears first as minute, dark spots on the surface of the green tissue of the strawberry. It gradually spreads, destroying the tissue as it advances, and later appears as a reddish outline, with a bit of dry, dead, light colored leaf tissue in the center. As the disease advances, the spots run together, which finally destroys the foliage. Oftentimes, it is scarcely noticeable to those who are not familiar with it until the fruit crop is nearly ripening, when it spreads rapidly, destroying the plants and with them the crop.

Making Peach-Buds Stick

W. H. G., Wapello, Iowa—In my experience the peach has been the easiest of all plants that I have budded. We used to have a saying when I worked in the nursery that all we had to do to a peach-tree was to throw a bud at it and it would stick and grow. Evidently you haven't had such success. You state that you have tried budding on about two hundred seedlings in all, but that you succeeded in growing a total of just two trees this way; that you did the work in the fall at the time prescribed.

I am inclined to think that one of your troubles is that you budded your peaches too late in the season. I would suggest that you bud them not later than the middle of August or, if we have a dry season, that it be done even earlier than this, and always before the bark sticks. The best stocks to use are seedlings grown from peach pits planted in the spring, and they should be budded about two inches above the ground.

These stocks would be rather small for budding in June; but in case they are budded in the ordinary way and the buds fail to take, they might be budded the following spring, from the latter part of April to the first of May. To do this, the bud-sticks may be buried in sawdust in an ice-house and kept dormant until used.

You ask if it would not be more practicable to bud in June. I think not; and yet if you are interested in this work there is no harm in trying. In your section the first half of the month would be best. It is often difficult to get buds at the time that are big enough to use; but even quite small buds, in the case of the peach, will often stick and do well if they are properly handled. If you do not think the buds are far enough along for successful budding, about a week previous to the time the buds are needed pinch the twigs that are to furnish the buds, which will throw the strength of the plant into the buds and cause them to increase in size very rapidly. In the case of June budding, as soon as the buds have grown fast the plant is cut off, and the strength of the plant forced into the newly-inserted bud, which causes it to start into growth the same season, and in your section it should make a growth of perhaps three feet the first year.

In case you have much trouble with buds dying out in winter, I would suggest that you cover all that are in good condition on the approach of winter with a coat of grafting-wax applied with a brush and then throw the earth up around them. In the spring of the year carefully remove the earth before the stocks are cut hack.

No Cure for Peach Yellows

E. B. K., Kansas—There is no cure known for peach yellows. Though this disease has been studied for many years, it is not even known what the real cause of it is, nor is its life history well known. It is thought to be a physiological trouble and not a special germ disease. The application of flowers of sulphur around the base of the trees after they are set out will have absolutely no effect upon this disease. The only known way of holding peach yellows in check is by removing and burning all infected trees as soon as the infection is seen.

Powers of sulphur, as a matter of fact, is of little value against either insects or disease, except in the case of some superficial molds, such as the powdery mildew of the grape and rose. For the ordinary downy mildew of the grape it is no preventive.

When to Set Catalpas

E. A. W., Ohio—The best time to set out catalpa trees secured from the nursery is in the spring. They can be set out at any time, when they are obtained or later, providing they have not started more than an inch of new growth. If they have started much more than this, there is some risk.

In the case of catalpa-seed you can sow it at almost any time up to the first of July, but I should prefer to get it in sometime before the latter part of May. The seed that stayed in the pods on the trees all winter is all right to use this spring.

The catalpa is a fast-growing tree, but its rate of growth varies greatly in different sections of the country. Under ordinary conditions, catalpa speciosa will make two or three fence-posts, to the tree when fifteen years old, and under best conditions in twelve years. The wood is of a beautiful brown color and it makes very pretty furniture or inside decoration and is durable in contact with the soil.

The United States Department of Agriculture has published a special bulletin dealing very fully with the subject of catalpa speciosa, which can be obtained by addressing that department, at Washington, D. C.

Galls on Roses

Miss A. McC., Minnesota—The specimen gall which you took from the roots of your roses was formed by insects—minute, wasp-like creatures, the eggs of which you can find in abundance if you cut these galls open. When the specimen reached my desk I found on cutting it that many of the wasps were fully matured in the eggs and evidently glad to be released.

If this insect occurred in great numbers it might do quite serious injury to the roses; but if it only occurred in a small way, I do not think this is the reason why your roses died down in summer. The only practical remedy for this pest is to gather the swellings and burn them while the eggs are still in them. This should be done early in the spring.

Black Knot

J. B., Napanach, New York—The specimen of diseased plum-branch which has a rough, black, swollen growth on it is affected by a disease known as "black knot." This is very common all through New York and generally wherever the European plum is grown. The best treatment is to cut off and burn infested branches, so far as may be, and then cut off the knots where the branches cannot be removed and paint the wounds with Bordeaux mixture.

Graflex Cameras

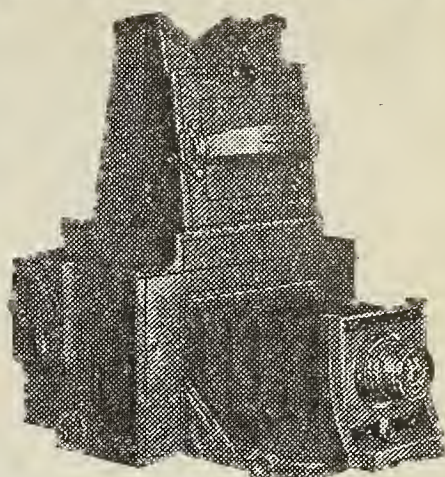

Reasons why the Graflex gives better results than any other Camera:

1. It is equipped with a Focal Plane Shutter working from time to 1-1000 of a second.
2. It is so constructed that the picture can be seen full size of negative, up to the instant of exposure, right side up.
3. It may be used with Film, Plates or Film Packs.
4. It will make perfect pictures under conditions that would result in failure with other cameras.
5. It is a hand camera instantly adjustable for the most exacting kinds of Photographic work.

Graflex Catalog free at your dealer's, or

FOLMER & SCHWING DIVISION
Eastman Kodak Co. ROCHESTER, N. Y.

POTATO DIGGER

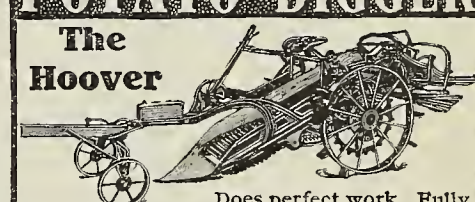

Does perfect work. Fully guaranteed. Write for illustrated catalogue of Diggers, Pickers and Sorters.

THE HOOVER MFG. CO., Box No. 22, Avery, Ohio.
Transfer points—Buffalo, N. Y.; Detroit, Mich.; St. Paul, Minn.; Marshalltown, Ia.; Idaho Falls, Id.; Portland, Ore.; Spokane, Wash.; Winnipeg, Man.; Hamilton, Ont.; Fond du Lac, Wis.



Self-Feed Eli Baling 3-Stroke Press

Latest addition to the great "Eli" family. Three strokes with automatic self-feed makes the gang hustle. Built on lines that make horse presses really valuable. Greatest leverage when pressure is hardest. Low Step-over. Full Circle, Block Signals, etc. A little giant in strength. We've always led as hay-press builders—18 different styles, horse and belt powers. All in one catalogue and it's free. Write for it.
Collins Plow Co., 1116 Hampshire St., Quincy, Ill.

Here's Good News on My 1910 Split Hickory Buggies

We have the largest exclusive vehicle and harness factory in the world. We buy all high-grade materials in enormous quantities—making tremendous savings. You share in these savings because we sell direct to you at factory price. That's why we save you 25% on any Split Hickory Vehicle you want—from our 125 styles.



H. C. Phelps
Manufacturer of
Split Hickory Vehicles

Let Me Pay Postage on My Big, New Book of 125 Styles to Your Home

SEND me your name now. I'll send you my book. Choose the Split Hickory you want. I'll guarantee to save you 25% on the retail price. Try it 30 days on your own roads. If it isn't all you expect—send it back. If you want to keep it—I'll guarantee it for 2 full years. If you decide to take my Split Hickory Auto-Seat Special—I'll save you \$26.50. Buy direct from the factory. Save the in-between profits. Keep them at home in your own pockets.

Just write me now—a postal. Know my offers before you buy. Just a penny to find out how to save 25% on the buggy you want. Write me.

The Ohio Carriage Manufacturing Co.
Station 27, Columbus, O.

Save \$26.50 Cash

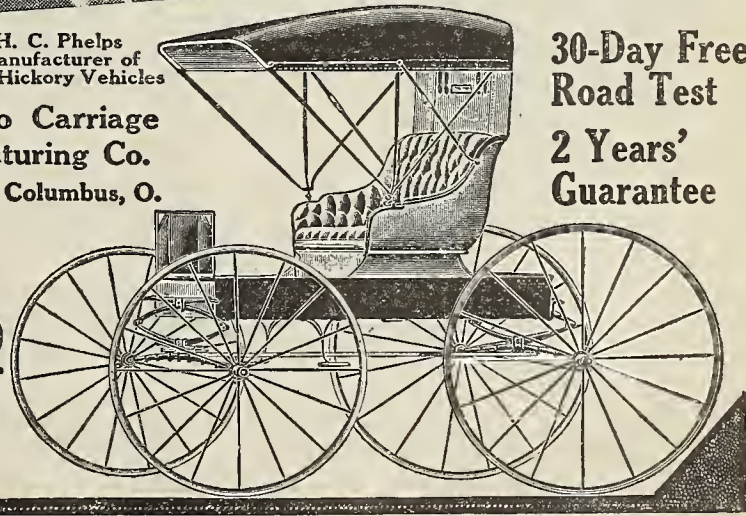

30-Day Free Road Test
2 Years' Guarantee

Made to Wear— Not to Wear Out



We never worry about selling Gal-Va-Nite. We make it to wear, then the selling takes care of itself.

It's made of stuff that will wear, materials which are carefully chosen for their use—flaked mica, Gal-Va-Nite Asphalt and long fibred wool felt.

We produce our own raw materials, put them together ourselves, and send you fifty years' roofing experience with every roll. Gal-Va-Nite is pliable so you don't break or crease it while getting it on the roof.

Just stop a minute, and ask for a sample of Gal-Va-Nite and our roofing booklet. Address the manufacturers.

UNION ROOFING & MFG. CO.
Main Offices and Factory
1141 to 1157 E. 7th Street
ST. PAUL MINNESOTA



This Steel Shingle Roof Outwears All

An Edwards "Reo" Steel Shingle Roof will outwear four wood roofs and six composition or tar roofs. It will save from four to five times its cost. Furthermore, it is fireproof and reduces insurance rates from 10 to 20 per cent.

Edwards "REO" Steel Shingles require no soldering. You can lay it yourself. Need only hammer and nails. Comes in stamped sheets of finest Bessemer Steel, 5, 6, 7, 8, 9 and 10 feet long, covering width 24 inches. Furnished painted or galvanized.

Factory Prices—Freight Prepaid. We are the largest makers of iron and steel roofing and pay the freight on all Steel Shingles; Plain, Corrugated, V-Crimp Roofing; Imitation Brick Siding, etc. Write for free catalog No. 483 and ask about our \$10,000 Guarantee Bond Against Lightning. (14)

The Edwards Manufacturing Co.
483-483 Lock St., Cincinnati, O.

Make Your Bicycle Into a \$60 MOTORCYCLE

at small cost by attaching the ERIE MOTOR. This includes all parts so that anyone can make a strong, durable machine that will climb steep hills and run for 3/4 per mile, 1,000 in use. Sample sold at cost. Send 2¢ stamp today for catalog.

MOTORCYCLE EQUIPMENT CO.
Hammondsport, N. Y.

"CHAMOIS SKIN" KHAKI WORK SHIRT
Best 50c Shirt in America

That's what its wearers—who number over two millions—say about it. Government test proved that Khaki was the best material for U. S. troops. 2,000,000 satisfied wearers are proof that our "Chamois Skin" Shirt is the best made 50c Shirt with a Dollar look. Our "Chamois Skin" label is your guarantee that it won't rip, fade or shrink. If your dealer can't supply you, send collar size and 50c in stamps for sample shirt and 25 New Colorings.

Oppenheim, Oberndorf & Co., 116 W. Fayette St., Baltimore, Md.

Freight Prepaid on "Breco" Rubber Roofing

Don't spend a dollar for roofing until you have seen and tested our old reliable "BRECO"—guaranteed waterproof, fire-resisting, durable Rubber Roofing. Made by our own special process, of long-fibre wool felt, saturated in asphalt. Heavily coated on both sides.

Free Cement and Special Roofing Nails included in each roll. Hammer lays it—Useful on ALL Buildings.

Lowest Factory Prices
Freight Prepaid on 100 lbs. or more

35-lb. Roll—108	
Sq. Ft.—1-Ply	\$136
45-lb. Roll—108	
Sq. Ft.—2-Ply	186
55-lb. Roll—108	
Sq. Ft.—3-Ply	226

Order today, or write for Samples and Booklet

Longest Guarantee
Send for samples or order now on our strong guarantee of satisfaction or money back. We pay freight to all points east of the western boundary line of Minnesota, Iowa, Missouri, and north of south line of Tennessee. Don't delay ordering; these special prices may not be offered to you again. Take advantage of them and write now, today—

THE BREESE BROS. CO., Roofing Dept. 24 Cincinnati, Ohio

WANTED—RIDER AGENTS in each town and district to ride and exhibit a sample 1910 Model "Ranger" bicycle furnished by us. Our agents everywhere are making money fast. Write at once for full particulars and special offer.

NO MONEY REQUIRED until you receive and approve of your bicycle. We ship to anyone, anywhere in the U. S., without a cent deposit in advance, **freight**, and allow **TEN DAYS' FREE TRIAL** during which time you may ride the bicycle and put it to any test you wish. If you are then not perfectly satisfied or do not wish to keep the bicycle you may ship it back to us at our expense and you will not be out one cent.

LOW FACTORY PRICES We furnish the highest grade bicycles it is possible to make at one small profit above actual factory cost. You save \$10 to \$25 middlemen's profits by buying direct of us and have the manufacturer's guarantee behind your bicycle. **DO NOT BUY** a bicycle or a pair of tires from anyone at any price until you receive our catalogues and learn our unheard of factory prices and remarkable special offer.

YOU WILL BE ASTONISHED when you receive our beautiful catalogue and study our superb models at the wonderful low prices we can make you. We sell the highest grade bicycles at lower prices than any other factory. We are satisfied with \$1.00 profit above factory cost. **BICYCLE DEALERS**, you can sell our bicycles under your own name plate at double our prices. Orders filled the day received.

SECOND HAND BICYCLES—a limited number taken in trade by our Chicago retail stores will be closed out at once, at \$3 to \$8 each. Descriptive bargain list mailed free.

TIRES, COASTER BRAKE and everything in the bicycle line at half usual prices. Interesting matter and useful information. It only costs a postal to get everything. Write it now.

MEAD CYCLE CO. Dept. C-83, CHICAGO, ILL.

Poultry-Raising

The Poultry-Yard in June

THIS is the month when conditions are most favorable for the free range of fowls. Crops are not far enough advanced to suffer from their investigations and the bugs and insects which are plentiful in grass and loosened earth give zest to the saunterings of the laying hen.

Broilers are in brisk demand. The fattening-pens should be moved to new locations and shaded from the heat of the sun. Birds of lanky frame that will not fatten within the desired weight should be given their freedom and reserved for early fall roasters.

Hens with chickens should be kept in each morning until the dew has dried off the grass.

The hen-house should receive special attention this month. The interior may be thoroughly disinfected by spraying with a lime-and-sulphur solution. Four pounds of lime and two of sulphur are mixed in four gallons of water and boiled for two hours. It is readily applied with a spray pump such as is used for spraying fruit-trees.

M. ROBERTS CONOVER.

Ducks and Geese

Don't try to raise ducks and geese in the same yard on the same rations. Ducks need more animal food than geese do. The latter need more green food—grass preferred.

Watch the young geese carefully for the fastest-growing males and females that have the required shape and color, and keep them for use as breeders the coming year.

It is not necessary to build the partitions in the duck-house more than two feet high, for ducks do not fly. This makes doors unnecessary, for the attendant can step over the low partitions in going from pen to pen.

The bad effects of close in-breeding show more quickly in ducks and geese than in land fowls. It is best to secure new drakes each year or, at least, each two years. Always be sure to select strong, vigorous birds with long, deep bodies, the kind that will improve your stock.

Whole or cracked dry grain should not be fed to ducks more than once a day or, as most breeders prefer, not more than three times a week. Mash should make up most of the ration, for the digestive apparatus of the duck is intended to handle principally moist, soft food.

A. S. VANDERVORT.

New Poultry-Housing Wrinkles

HERE are some new ideas in poultry-house construction. I have seen them applied in but one poultry-house, built by my father.

The new points of the plan are plainly brought out by the accompanying small sketch, showing an end section of the house. The dimensions can be varied to suit the builder, of course. The first point to be noted is the placing of the dropping-board (A) which slopes toward the rear of the house instead of toward the front, being two feet from the floor at the rear and four in front, and extending to the middle of the house. A trap-door (B) six inches wide, hinged at the top and running the length of the house, permits the dropping-board to be easily cleaned, the scrapings being caught in a trench or otherwise. The board is made of shiplap lumber, and by using sawdust and a small scraper it can be very easily and thoroughly cleaned mornings.

This arrangement gives the whole floor space for scratching-floor, and the litter does not have to be changed nearly so often. The roosts (R) can be run lengthways of the house and supported in the usual way, as shown, or they can be run crossways of the house, from the front of the dropping-board to the back wall.

The second nice point about this plan is the arrangement of the windows (C), of which there are three, running alto-

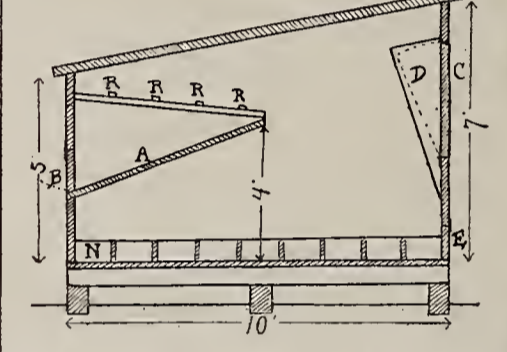

gether about two thirds of the length of the house. They are hinged at the bottom to open inward. A triangular board (D) fits close to each side of the windows. When the windows are opened ten or twelve inches, to the position shown by the dotted line, all the air has to come over the top of the window, giving perfect ventilation without a draft.

The above-mentioned house built on this plan is twelve feet wide, twenty-four feet long, seven feet high in front and five at the rear, and can, if necessary, accommodate one hundred chickens. The nest-boxes (N) are placed along the sides and rear of the house. Small trap-doors (E) let the fowls in and out, and there are doors near each end of the front for the attendant. F. M. HAINES.

Enforce Egg Honesty

THERE had come to my notice in the last six months no less than three different articles in the newspapers of some one finding a name and address on an egg, and upon writing, finding the address was written a great while ago (at least in comparison to the proper age of an egg). One cannot believe all one reads in the newspaper—but certainly thousands of dozens of eggs are being kept in cold storage and sold as the fresh article.

It seems to me there ought to be some way to prevent this. Here is my plan. Let every one who keeps hens own a rubber date and stamp—it only costs a few cents—and stamp the date upon every egg when it goes to market. There will be no disguising the storage egg then. Supposing it does take a few cents at first and a few moments of your time, the thought of the good we are doing should warm our hearts enough for pay. It might be possible to get the ink off, but the trouble of doing it would be about as much as the egg was worth.

E. L. T.

If little chicks are missed and their bodies cannot be found, look out for cats or rats.

As soon as the grass and weeds have made a good growth, look out for hidden nests if the hens have free range. The value of the eggs in a few of these nests will be considerable.

Chicks that have started off well grow remarkably fast and soon crowd the coop which afforded plenty of room at first. Divide the flock or furnish a larger coop, else some will have to roost outside.

25 Superb 4th of July Post-Cards

Celebrate the 4th

SENDING a 4th of July post-card to each of one's friends is going to be very popular and stylish this year. Never has 4th of July been more popular as a holiday than at present. In no better way can you celebrate it than by sending a beautiful patriotic post-card to each of your friends. FARM AND FIRESIDE has obtained the handsomest collection of 4th of July cards ever made. You can get them without spending a cent.

Each Card a Beauty

The 25 cards are all different, and each card is printed in twelve colors and gold and is handsomely embossed. A handsome patriotic picture is shown on each card, and will give a lot of pleasure to the person to whom you send it. Don't miss the chance to get this set of beautiful post-cards.

How to Get the Cards

Send us two new 8-month subscriptions to FARM AND FIRESIDE, at 25 cents each, and we will ship you a package containing the twenty-five 4th of July post-cards, postage prepaid. Send to

FARM AND FIRESIDE, Springfield, Ohio

BOYS! You Can Get This Air-Rifle

Without Spending One Cent

The King Air-Rifle is a repeater. It shoots 150 times without reloading. It is strong, durable and shoots accurately. It cultivates trueness of sight and evenness of nerve.

This rifle is harmless. It uses no powder—just air. There is no smoke, no noise. Air is plentiful and shot costs but 10 cents for 1,000.

These fine air-rifles are provided with pistol-grip, true sights, and are so strongly made that it is almost impossible for them to get out of order.

Boys have use for it every minute—hunting in the woods, shooting at targets, drilling as soldiers, and innumerable uses that only boys can discover. Every boy will want one of these rifles, and this is an unusual opportunity to get one absolutely without cost. Get your subscriptions at once and send your order in early.

On the Job

Send a postal to FARM AND FIRESIDE to-day. Just say you want an Air-Rifle without having to pay one cent. Thousands of happy boys easily earned them this way. Write to-day. Address

**FARM AND FIRESIDE
SPRINGFIELD, OHIO**

Crawford County, Pa.
Income \$2121. In 1909
80 Acres \$3700

On main road, only 12 miles to village; fine high school, creamery, etc.; cuts 21 tons hay to acre, 12 cow pasture, 300 maple trees, complete sugar outfit; half cash; sacrificed for immediate sale by aged woman. For full details of house, barn, etc., see page 18, Crawford County, Pa., section. "Strout's Farm Catalogue, 2nd Edition." It describes other farms in Western Pennsylvania and Ohio, from \$300 up. Copy mailed Free. Station 2699, E. A. Strout, Union Bank Bldg., Pittsburg, Pa.

MINNESOTA HAS 1,000,000 ACRES open for HOMESTEAD ENTRY, offers Cheap Land, and Farm Employment. Write for literature and full information. STATE BOARD OF IMMIGRATION, Room 226, State Capitol, St. Paul, Minn

Live Stock and Dairy

Why Experiment With Crosses?

THE question of which breed of swine to select for the economic production of pork is perhaps of less importance to-day than it has been in the past. The leading swine-breeders have begun to recognize the fact that they must shape their favorite breeds to meet market demands. The result of this has been that the type of all the leading breeds of swine now conforms to a certain standard that meets the demands of the packing-houses.

I will not discuss the bacon breeds of swine, for, owing to the scarcity of the bacon type, there is little effort to distinguish them as a separate market class. The hog that best meets the demands of the present time is a well-muscled hog that will supply a fair amount of lard and fat meat well marbled with lean and be ready for market at any desired age.

Practical pig-growers and feeders of market hogs look for quality, depth, length and width of form and uniformity of type, regardless of the breed, color and characteristic markings. However, it is essential that we select our breeding

failure with one breed can hardly hope to succeed with another. Judicious care will bring success with and breed.

All practical hog-breeders agree that crossing the breeds is a dangerous practice and that the best results are attained by sticking close to one breed. Yet some men still cling to the idea that it is possible to incorporate all of the good qualities of the different breeds in one cross-bred animal. It is a disastrous belief.

For one purpose, it is true, crossing is successful, and that is in the production of fancy pig pork among the dairy farmers in the Eastern states. A cross between a large brood sow and a small brood male, such as the Essex, etc., is employed, but the breeding is not carried beyond the first cross and well-bred animals are used for breeding. The object of this cross is to get a strong constitution and early maturity, and also to secure pigs adapted to a ration composed largely of dairy by-products with a small amount of mill-feed. But while such cross-breeds prove useful in the dairying sections of the East, they are not adapted to conditions in the great corn

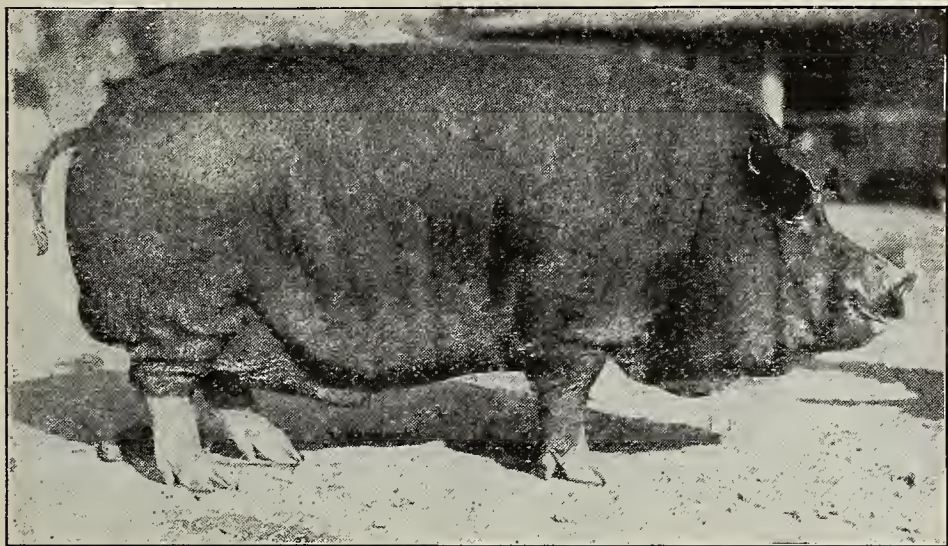

Poland China Boar, Showing Valuable Conformation Fixed by Pure Breeding

swine from some well-established breed, for promiscuous mating of hogs of various breeds has a tendency to destroy the type of all the breeds employed in the crosses and to throw away the results of years of systematic selection and mating to establish and perpetuate a certain fixed type in the breed.

This point has been illustrated by mating a half Poland China and half Chester White sow with a pure-bred Berkshire boar. The pigs resulting from this cross were red, spotted, speckled and striped, showing that the improved type of all three breeds used in the experiment was lost and with it the improvements in color and markings. The result was the return of the offspring by the principle of heredity to the original scrub type.

All of our swine, especially the improved breeds which are modified forms of the original, will not reproduce themselves perfectly unless guided by the hand of man. Whatever breed is selected should be kept pure and only the best individuals retained for breeding.

The man who is making a specialty of producing pork should grasp every opportunity to improve his breeding stock, the same as the man who is breeding registered swine. Uniformity of type is an important thing in the successful management of feeding hogs, especially near market-time, and a uniform bunch of hogs will bring more money on any market than a mixed lot. A pure-bred lot of hogs are much more likely to mature together and to please the discriminating buyer.

In selecting a breed we should give attention to its adaptability to the environment under which it is to be placed. Some are good rustlers, some are quieter and better adapted to a small feed-lot. In the Northern states color is of little importance, but in the South a large number of pork-growers prefer a black hog, as being less susceptible to the heat and sun. However, some Southern hog-growers still cling to white hogs and seem to experience little difficulty from that source.

The breeds that have proved best adapted to your climate and conditions in the hands of farmers and feeders of your locality are the safest breeds to invest in. We all have our preferences, our likes and our dislikes, our favorite color markings and our hobbies, but from the standpoint of dollars and cents there is no one best breed. All breeds possess many good qualities and some less desirable ones, and the man who makes a

belt, where pork production is a leading feature of the farm operations.

The man who is experimenting with the various breeds and crosses in search of something better than has yet been discovered may have an important work, but such a line of investigation would not be practical for the man who must depend upon his hog feeding for his farm profits. He can do better by confining his operations to one well-established breed. W. MILTON KELLY.

In our last issue, Mr. Armistead presented the case for cross-breeding. Mr. Kelly here gives the opposing view. We should be inclined to cast our vote with Mr. Kelly. There is no doubt that, for some special purposes, desirable animals can be produced by crossing the pure breeds; but, as a general rule, the pure-bred hog, not necessarily fancy bred, is the surer investment. EDITOR.

Give the Cows Pure Water

FROM NOW ON, throughout the long, hot summer days, the poor, dumb animals on many farms will be compelled to quench their thirst from some filthy, germ-infested slough or from a water-tank filled with hot, sloppy, stagnant water.

It seems strange that farmers are so neglectful and thoughtless—and, shall we say, cruel? If the moral side of the question does not appeal to their better selves, common reason ought to teach them that they lose cowflesh and dairy products by allowing the cows to drink bad water.

Then, there is still another phase to the situation: The quality of the water cannot help but affect the quality of the milk. Sanitation demands that we wake up to the perils attending the methods employed by many dairymen during the hot season. For the sake of the dumb, helpless animals; for the sake of ourselves, our families and every consumer of our dairy products, let's furnish our Bossies with an abundance of the purest and freshest water obtainable, if we do nothing else for them these hot days.

Of course, if we see that they are provided with a cool, shady nook to lie down in and chew their cud, and if we help them fight the pesky flies with a good sprayer and an effective fly-repellent, they'll maintain our dairy products accordingly. And we'll feel more as if we had done by our stock as the Creator intended we should. M. A. COVERDELL.

EVERYBODY HAVING COWS WILL SOME DAY USE A DE LAVAL CREAM SEPARATOR



Nearly 1,200,000 farmers, creamerymen, milk dealers and owners of country homes, throughout the world, are already using De Laval Cream Separators, and 150,000 or more are being added to the number every year—many more this year than ever before.

If you haven't a De Laval Cream Separator already you can't be anywhere near the head of this tremendous procession that started thirty years ago, but it will be foolish to wait to bring up the tail end of it.

The use of a De Laval Cream Separator—with even a single cow—means more and better cream and butter, warm and sweet skimmilk, less labor and more profit, twice a day every day in the year.

A De Laval Cream Separator saves its cost in a few months, not only over any other method of creaming milk but over any imitating cream separator.

Then why not fall into the De Laval procession now? You can't recover the waste and worry of previous years, but you can stop it going further. Why not do so? Every day of delay means just that much more waste of product, quality and dairy comfort. Why prolong it?

De Laval Cream Separators are made for one cow to one thousand, in proportionate size, style and price, and sold for cash or on such reasonable terms that they actually pay for themselves.

They are sold direct or through local agents. If you don't know the nearest agent write for his name and a catalogue, which we shall be glad to send you.

THE DE LAVAL SEPARATOR CO.

165-167 BROADWAY
NEW YORK

42 E. MADISON STREET
CHICAGO

DRUMM & SACRAMENTO STS.
SAN FRANCISCO

173-177 WILLIAM STREET
MONTREAL

14 & 16 PRINCESS STREET
WINNIPEG

1016 WESTERN AVENUE
SEATTLE

NEWTON'S HEAVE
COUGH, DISTEMPER AND INDIGESTION CURE
 The Standard Veterinary Remedy.
 20 years sale. Send for booklet.



SAFE TO USE BEST CONDITIONER

Makes the horse sound, stay sound

DEATH TO HEAVES
 The first or second \$1.00 can cures. The third can is guaranteed to cure or money refunded.
 \$1.00 per can at dealers, or express prepaid.
 THE NEWTON REMEDY CO., Toledo, Ohio.

Shoo-Fly THE ANIMALS' FRIEND
KILLS EVERY FLY



it strikes when our gravity sprayer is used. Keeps insect pests off animals in pasture longer than any imitation. Used since 1885. Thousands of dairymen duplicate 10 to 50 gallons annually after testing imitations. Absolutely harmless; cures allsores.

30 cents worth saves \$10
 worth of milk and flesh on each cow during fly season. No Lice in Poultry House or any place it is sprayed. If dealer offers substitute, send us his name and \$1 for 3-tube gravity sprayer and enough SHOO-FLY to protect 200 cows. Name express office. \$1 returned if animals not protected. Free booklet. Special terms to agents. Shoo-Fly Mfg. Co., 1316 N. 10th St., Phila., Pa. FARM AND FIRESIDE GUARANTEES SHOO-FLY to be O. K.

MINERAL HEAVE REMEDY
CURES HEAVES



NEGLECT Will Ruin Your Horse
 Send today for only PERMANENT CURE
 SAFE CERTAIN

\$3 PACKAGE will cure any case or money refunded.
\$1 PACKAGE cures ordinary cases. Postpaid on receipt of price. Agents Wanted Write for descriptive booklet

MINERAL HEAVE REMEDY CO., 425 Fourth Ave., Pittsburg

CIDER PRESSES

THE ORIGINAL MT. GILEAD HYDRAULIC PRESS produces more cider from less apples than any other and is a BIG MONEY MAKER
 Sizes 10 to 400 barrels daily, hand or power. Presses for all purposes, also cider evaporators, apple-butter cookers, vinegar generators, etc. Catalog free. We are manufacturers, not jobbers.
 HYDRAULIC PRESS MFG. CO., (Oldest and largest manufacturers of cider presses in the world.)
 106 Lincoln Avenue, Mount Glend, Ohio
 Or Room 109 D, 39 Cortlandt Street, New York, N. Y.



62 Acres \$3400
 \$2320 Last Year's Income

Pleasantly located in outskirts of one of Pennsylvania's finest villages (40 stores) in a prosperous agricultural section; 48 acres in dark rich loam fields, balance wood and pasture; fine lot apples, pears, plums, cherries, peaches, and grapes; 6 room house, convenient barn; receipts in 1909 were as follows: dairy \$720, stock \$300, potatoes \$700, pork \$200, grain \$200, hay \$150, fruit \$50, sacrificed to close immediately for \$3400 with \$800 down and easy terms. For traveling instructions see page 19 "Strout's Farm Catalogue, 2nd Edition" copy free. Station 2099, E. A. Strout, Union Bank Bldg., Pittsburg, Pa.

Monarch Hydraulic Cider Press



Great strength and capacity; all sizes; also gasoline engines, steam engines, sawmills, threshers. Catalog free.

Monarch Machinery Co., 603 Cortlandt Bldg., New York

Fernald Dash Rein Holder
 protects you against runaway when horse is left unwatched. Keeps the reins from under horse's feet. Switching tail cannot jerk reins loose. Fits tight on any dash. Lasts as long as the buggy. No bolts or screws required. Simply slips on dash and stays in place. Is ornamental too. Nickel or baked japan finish. Too low priced for you to be without it. Ask your hardware or harness dealer or write us.

Fernald Mfg. Co. North East, Pa.

LAMENESS from a Bone Spavin, Ring Bone, Splint, Curb, Slide Bone or similar trouble can be stopped with

ABSORBINE

Full directions in pamphlet with each bottle. \$2.00 a bottle at dealers or delivered. Horse Book 9 D free.

ABSORBINE, JR., for mankind, \$1.00 a bottle, removes Painful Swellings, Enlarged Glands, Gout, Wens, Bruises, Varicose Veins, Varioisities, Old Sores, Allays Pain.

W. F. YOUNG, P. D. F., 23 Temple St., Springfield, Mass.

Income Guaranteed

Liberal commissions; big cash prizes; a guaranteed monthly salary. Such are some of the inducements for you to handle the biggest money-making offer ever made by a farm journal. A fine opportunity for energetic young men and women. Experience not necessary. You must act at once.

FARM AND FIRESIDE
 Department of Agents
 SPRINGFIELD, OHIO

Boiling Water Beats Cold

I HAVE just read with interest an article by E. L. Vincent, in your issue of April 10th, telling how one woman managed the care of her milk-utensils. As I have lived on a ranch and been a butter-maker for the past twenty years, I feel my experience in that respect has been worth something.

The article said nothing of the careful scalding of all things used in the care of butter and milk, which I consider of the utmost importance. Rinsing with cold water will not do. Neither am I satisfied with hot water. The water must be actually boiling. Boiling water at the last rinsing not only cleanses, but disinfects.

I think a strainer of coarse muslin much to be preferred to a wire one. It is easier to keep clean and does its work better. It ought to have the same treatment as the milk-vessels, first a rinsing in cold water and then a scalding.

I agree with the woman whose story was told in the article about the use of a firm, smooth towel, kept especially for the milk-things. But all this care is of no use unless cleanliness begins at the barn. The milker must be cleanly. My husband has always washed the cow's udder and his hands before milking, and the stable is kept thoroughly clean.

Sunning milk-vessels is a good practice, but how about rainy days? Scalding the milk-things every day is the best system.

MRS. G. H. WILLIAMS.

The above letter from Pullman, Washington, lays down an absolutely sound principle. Boiling water is the only thing to use at the last rinsing. The old practice of sunning milking utensils is first class; even winter sunlight, without much heat in it, will kill germs. The light does the work. But whether utensils are sunned or not, they ought to be scalded.

EDITOR.

What to Do for "Cribbing"

A PENNSYLVANIA subscriber writes regarding an eight-year-old horse which has acquired the habit of "cribbing," or wind-sucking. "The habit has not badly worn his teeth as yet, but the manger is badly worn away, for he is constantly at it. When tied so he can reach nothing he still snaps wind through his teeth. He seems lazy, tired and in poor condition for a carriage-horse."

I am sorry to say that I know of no cure for cribbing and I do not believe there is any. Prevention, however, can be had through keeping a wide, stiff strap always around the horse's neck. There is a strap made for this purpose that does the best of anything I know. There is not much demand for them, however, and so only firms that aim to carry a very full line of horse-goods are likely to have them. But I have myself generally used a plain strap, such as one can have made at any harness-shop, and found it all-sufficient. Be sure to have it two and one half or three inches wide and of good stiff leather, and buckle it on pretty tight.

The habit is a bad one and very trying to the owner, and the horse's run-down condition is probably to be attributed to it. Still, if he is a good horse every other way, his qualities may offset the trouble of keeping the neck-strap on him and you need have no fear of its hurting him. I have known some very good horses that have had to wear such straps all their lives.

DAVID BUFFUM.

Boiled-Down Wisdom

Oratory is not statesmanship, neither is yelling horsemanship.

Gargetty milk may cause throat or bowel diseases in those using it.

One or two more hogs in the pen this year will buy all the Christmas presents next December.

The housewife will find churning a most trying and difficult task if the salt-supply of the dairy herd is neglected while the cows are gorging themselves on fresh, green grass.

Fling those hot, filthy, sweaty collar-pads in the ditch and let the horses' shoulders work against a firm, smooth collar that you can keep clean and cool. That means, of course, a collar that fits right.

A tuberculous cow may not give tuberculous milk, but the germs are sure to be about her and to infect the milk. Then the calves, the pigs and the children will be infected. A tuberculous cow is worse than none.

The farmer who keeps all dust and other foreign matter out of his milk, who cools it properly as soon as he can after milking and who sends it from the dairy clean, pure and sweet is doing more to promote the health and well being of the community than all the doctors for miles around.

CROP PROTECTION
The Gun for the Farmer

You can protect the acres of corn and oats or whatever you grow, from the crows and other pests that are such a nuisance to the farmer. Weasels, Gophers, Hawks, Blue Jays, Rabbits, Woodchucks, etc.

Here's a Repeating Rifle that you can shoot 15 times without reloading.

List Price \$8.00

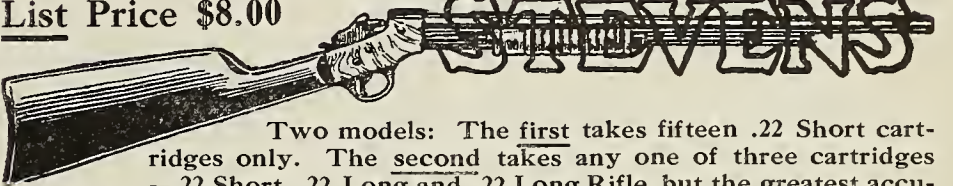

Two models: The first takes fifteen .22 Short cartridges only. The second takes any one of three cartridges—.22 Short, .22 Long and .22 Long Rifle, but the greatest accuracy is obtained in this model by using .22 Long Rifle cartridges.

THE STEVENS VISIBLE LOADING REPEATING RIFLE IS GUARANTEED TO BE THE MOST ACCURATE .22 REPEATER MADE

It is rifled with the care and precision that has made the name Stevens famous the world over. It shoots straight and it hits hard. There is no Repeater at the price that has the work and finish which is put into the No. 70.

List Price \$6.00

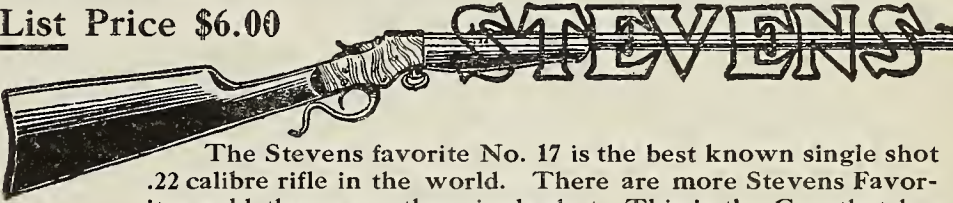

The Stevens favorite No. 17 is the best known single shot .22 calibre rifle in the world. There are more Stevens Favorites sold than any other single shot. This is the Gun that has made the Stevens reputation.

If you are looking for a good Shotgun at a moderate price, write us and we will send you full details and price list. We make shotguns (Single and double barrel hammer and hammerless) that you can buy at prices listing from \$7.00 up to \$60.00

Our No. 520 Hammerless 6-shot Repeating Shotgun is a marvel at the figure. (List price \$27.00.) Besides shooting with the very best pattern and penetration, the Stevens No. 520 has a feature which no other repeating shotgun has—IT IS THE ONLY REPEATING SHOTGUN MADE THAT CAN BE OPERATED AS FAST AS THE HUMAN HAND CAN MOVE WITHOUT DANGER OF BALKING. This is because the empty shell and the loaded shell travel by separate routes—they cannot meet.

DO YOU WANT TO BE A BETTER SHOT?

It's the fine points that make the big difference between the expert and the ordinary shot. Experts don't give away these points they spent long years to get. But it's to our advantage that present and future users of Stevens rifles and shotguns become expert shots. We employ some of the world's crack shots. They know all the little kinks—the fine points that get them big scores.

Do you want these short cuts to expert shooting? Then write us what interests you—rifle shooting, the traps or field-shooting. Our answer goes the day your letter comes, giving you practical suggestions on how to improve your style and accuracy.

J. STEVENS ARMS & TOOL COMPANY, Dept. 736, CHICOPEE FALLS, MASS.
 THE FACTORY OF PRECISION

List Price of Stevens Rifles

Little Scout No. 14	\$2.25	Favorite No. 17 (The only Boy's Rifle used by Men)	\$6.00
Stevens-Maynard Jr. No. 15	3.00	Visible Loader No. 70	8.00
Crack Shot No. 16	4.00	Ideal Rifle No. 44	10.00

(For Young Shooters. Accurate and made for real work)
 (Man's heavy Single Shot Rifle)

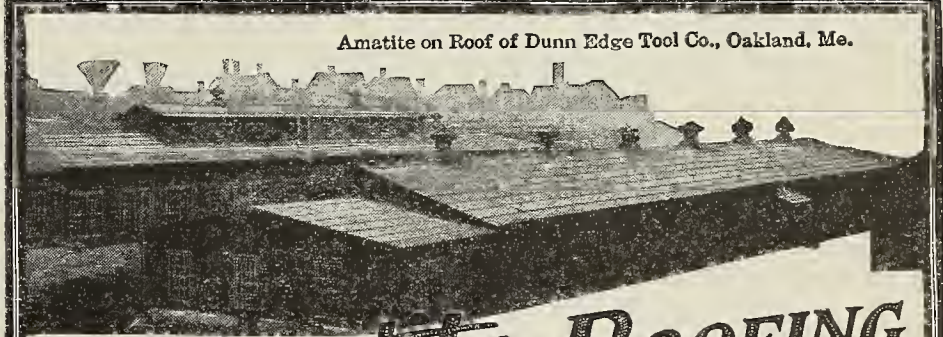

Amalite Roofing
NEEDS NO PAINT

EVERYTHING nowadays is constructed with the view to save time; to save labor; to save money.

These are the primal points which have made Amalite successful. That these things have been achieved such letters as the one below fully prove.

"Oakland, Me., Feb. 2, 1910.
 Barrett Mfg. Co.
 During the past twelve years we have used several different brands of Ready Roofing; some of these have cost much more than Amalite, but we are free to say that we prefer the latter. Not only does it give fully as good service, but it requires no painting or coating, as some of the others do. We consider this a most desirable feature.
 Yours truly,
 DUNN EDGE TOOL CO.,
 By R. W. DUNN, Treas."

These letters come to us constantly. Amalite doesn't leak, and never needs to be painted. Its cost is low; its service long. It saves time, labor and expense.

Its real mineral surface and coal tar pitch waterproofing are responsible for this. We know what Amalite will do. We want you to know. Therefore we offer you a sample free.

Just send your name on a postal to nearest office.

BARRETT MANUFACTURING Co.
 New York Chicago
 Philadelphia Boston
 Cincinnati Minneapolis
 Cleveland Pittsburgh
 New Orleans
 Kansas City St. Louis



SUBSCRIPTION PRICE

One Year (24 numbers) 50 cents
 Canadian Subscriptions . 1 Year, 75 cents

Entered at the Post-Office at Springfield, Ohio, as Second-Class Mail Matter.

Subscriptions and all editorial letters should be sent to the offices at Springfield, Ohio, and letters for the Editor should be marked "Editor."

The date on the address label shows the time to which each subscriber has paid.

Subscribers receive this paper twice a month, which is twice as often as most other National farm journals are issued.

Silver, when sent through the mails, should be carefully wrapped in cloth or strong paper, so as not to wear a hole through the envelope.

When renewing your subscription, please say it is a renewal, and if possible send the label from a recent copy. If all our subscribers will do this a great deal of trouble will be avoided.



PUBLISHED BY
THE CROWELL PUBLISHING COMPANY

SPRINGFIELD, OHIO

Branch Offices: 11 East 24th Street, New York City

Tribune Building, Chicago, Illinois

Copyright, 1910, by The Crowell Publishing Company

ABOUT ADVERTISING

FARM AND FIRESIDE does not print advertisements generally known as "readers" in its editorial or news columns.

Mention FARM AND FIRESIDE when you write to our advertisers, and we guarantee you fair and square treatment.

Of course we do not undertake to adjust petty differences between subscribers and honest advertisers, but if any advertiser in this paper should defraud a subscriber, we stand ready to make good the loss incurred, provided we are notified within thirty days after the transaction.

FARM AND FIRESIDE is published on the 10th and 25th of each month. Copy for advertisements should be received twenty-five days in advance of publication date. \$2.00 per agate line for both editions; \$1.00 per agate line for the eastern or western edition singly. Eight words to the line, fourteen lines to the inch. Width of columns 2 1/4 inches, length of columns two hundred lines. 5% discount for cash with order. Three lines is smallest space accepted.

Letters regarding advertising should be sent to the New York address.

Freight Rates Go Up! Why?

EVERY increase in the freight rates on farm products on their way to market is just so much out of the price of what we grow.

Every increase in freight rates on commodities used on the farm is just so much added to the cost of living.

In each case, it is a matter of direct significance to every farmer. It bears on the question of whether he shall have hard times or good times, whether he shall live like a civilized man in the twentieth century or not.

At this writing freight rates are being boosted by the railways all over the country. The advances are tremendous in their aggregate. They range from thirteen per cent. to fifty per cent. and are being made effective as fast as the conflicting interests of the railways themselves can be reconciled. This is admitted by traffic officials of both Eastern and Western roads.

The time has gone by in this country forever when the people will accept the rates fixed by the railways just as they accept the charges of draymen for haulage. Courts and codes have established the principle that railway rates are properly subject to governmental regulation.

We have the right to ask why rates have gone up, and are going still higher, and to expect an answer. It is emphatically our business. Mr. Brown, of the New York Central, asserts that the increases in wages to railway employees will amount to a hundred millions a year, and that increases in rates are necessary in order that they be paid. Mr. Brown does not say so, but it is well known that he and other railway managers are hurrying to get their advanced tariffs filed so as to forestall the anticipated provisions of the bills pending in Congress giving the Interstate Commerce Commission power to suspend rate advances. These two reasons may or may not harmonize. There can be no doubt that the rates would have been shoved up more gradually and imperceptibly had it not been for this pending legislation. The Interstate Commerce Commission cannot suspend these advances and look into their necessity. After the law is changed it looks as if it will have that power. If the necessity Mr. Brown mentions exists, it would seem that no apprehension need be felt that a fair commission would interfere with the advances.

The shippers' organizations all over the United States are boldly forming in line of battle to fight the railways' proposed increases in rates. The great farmers' organizations, North and South, should line up with them. On the face of the arguments as developed to date, the net incomes of the railways do not show any necessity for the advance in rates. Until such necessity is shown, the great-producing interests should stand shoulder to shoulder with the consumers against this one-hundred-million-dollar-a-year slice from the incomes of the people. When the railways show the necessity for the advance, the courts and commissions will consent to it, must consent to it. Until then, the business of the nation should fight it. Let us all be from Missouri, and when they say they are forced to this advance in order to pay just returns, let us all say "Show us." We are willing to accord justice. We should as Americans be ashamed to accord less.

* * *

There is an honest way of turning water into milk—give the cows plenty of it to drink.

Curves make beauty, but a perfectly straight road along a field of corn with perfectly straight rows looks good enough to the farmer.

If you think in a circle, broaden a little all the time, so that your mind may be as the ever-widening spiral, getting more and more within its grasp continually.

On the very day when the United States Senate was wrestling with the question of legalizing railway agreements to fix railway rates, a man named Homer appeared before the Interstate Commerce Commission and filed on behalf of twenty-five railway systems tariff sheets fixing exactly the same rates on all of them!

If you are married to foggy notions, get a divorce.

To-morrow will not be better, unless you yourself are better to-morrow.

When a man is forced to gather his wild-oat crop, he finds harvest-hands scarce.

A little money now and then is relished by the most of—women; see that they get it.

A mighty good way to get a bigger farm is to make the one you already have produce more.

Some farmers are too busy in their corn-fields to stop and read the papers—and miss the item telling how to double the crop. A better way is to rest—and read an hour at noon. Such time is never lost.

Exit Edward VII.—Enter George V.

KING EDWARD the Seventh is dead, and King George the Fifth sits on the throne of the British Empire. The late king was a skilful diplomat and a great power for good in the tangled international relations of the British Empire. He has been a better king than many a greater man would have been. He has shown great common sense, great good-humor, great tact and an unflinching desire to accomplish the good of the nation in those things in which he was interested. He was not much interested in the internal politics of the realm, and he died at the time when he faced the dilemma of choosing between the Lords and the Commons in the first great crisis England has experienced since 1830.

The Edwards have been men of ability all through English history, and some of them men of commanding ability. The name has been an asset for the late king. The Georges, on the other hand, have been utter failures as kings. The new king has the chance to redeem a name historically disgraced. He stands in the spot-light on a stage set for a great historic drama, the end of which no man knows. British institutions are on trial. Suddenly, it has been found that the Commons are not sure of their supposedly conceded position as the ruling body of Great Britain. The Lords are all at once found to be reclaiming the power to rob the Commons of rulership when the Liberals are in power, while acting with the lower house when the Conservatives win. Such a deadlock cannot long exist. George V. faces a fair possibility of a revolution, which will either carry down the Lords, and perhaps the King, or reestablish absolutism in the privileged classes.

* * *

All persons interested in irrigation by wind power should ask their representative in Congress for Farmers' Bulletin Number 394. It tells about matter from almost every point of view—mechanical, agricultural and financial.

Rev. B. A. Loving, of Oklahoma, would like to hear from people having old papers and magazines for mission work. Over one thousand families in his district need them; he has found some homes wholly destitute of wholesome reading matter. He asks all readers wishing to help to send no literature to him, but to write him for name and address, and send direct to some frontier home. His address is Woodward, Oklahoma.

Our Failure as Shepherds

A COMPANY in New York, which is entering upon the business of importing meats from Australia, expects all this summer to land fifty thousand fresh mutton carcasses a week. A correspondent of FARM AND FIRESIDE at Kansas City says under a May 1st date: "I've been spending some hours among the sheep at the stock-yards and am astonished at the poor and uneven quality of the general run of them. Prices might fall twenty-five per cent. from the present rates and yet give good profits." If these two facts be compared, the poor and uneven quality and high prices of American sheep explain the importations. But what explains the failure of the American farmer to take advantage of the opportunity to make a good profit and twenty-five per cent. on top of that?

A Railway Man's Advice

HERE are some words of wisdom from Mr. B. F. Yoakum, of the Frisco. They are from his remarks at the Farmers' Union at St. Louis.

The United States Steel Corporation is one of the best managed and has the largest list of stockholders of any organization in the country. Its stockholders are largely distributed, being in every state in the Union. Your organization has a membership of several millions. The steel company watches its chances for profit and expansion. It encourages railroad construction to remote places where transportation is necessary to promptly and economically handle its business. Your organization gives no attention to these subjects. The steel company fixes the price for which it sells its goods. You sell yours for the price the buyer fixes. The steel company quotes its prices to the buyers. You put your products on sale and the buyers make your prices. If organized, you can have something to say about the prices for which you sell.

The Standard Oil Company is admittedly the best managed commercial organization of the world. Every economy is practised, every unit of expense is at a minimum, every force works in harmony with every other force, every department is organized in a manner to assist every other department. Oil is the only commodity of common use in every family that has shown a decrease in cost to the consumer in the last ten years.

I use the Standard Oil to illustrate what business organization will do. If the same principle is applied to the farming interest, so that every saving is made from the farm to the consumer, starting with good public roads, warehouses where the products can be stored for the market, it would not be unreasonable to say that the increased profit to the men who produce, on the present production, would be twenty-five per cent. which in revenue to the American farmer would mean an additional two billions of dollars annually.

Nothing stronger in favor of coöperation among farmers has ever been said by their own speakers. The ideal Mr. Yoakum holds out is no less than that of as close an organization among farmers as that of the United States Steel Corporation or the Standard Oil Company. Such an ideal may be impossible; but if ever attained, this will be a nation governed and controlled by farmers, instead of by oil and steel.

OUT OF THE LETTER-BOX

IN FARM AND FIRESIDE of January 25, 1910, I notice an editorial headed "Some Consumers' Dollars" which I think must have been written by some one who had not made a thorough investigation of Swift and Company's affairs. It is true Swift and Company have a capital of sixty million dollars and a surplus of twenty-two million dollars, but it is also true that they have been twenty-four years accumulating this, and considering their volume of business I do not consider it very much out of the way. Even their earnings of 13.66 per cent. are not so very unreasonable for a manufacturing concern. You, no doubt, will admit that a stockholder in such a concern would not be unreasonably rewarded if he were paid ten per cent. annually, and that a healthy concern should carry something to the surplus account for a bad year.

Your editorial should have gone on to show that Swift's sales were two hundred and fifty million dollars in 1909, on which they report a profit of eight million one hundred and ninety thousand dollars, or about three and one fourth per cent. on their sales. Is it unreasonable that they receive this small profit on every dollar's business they do? It means the addition of only a small fraction of a cent to every pound of material they handle. Do you suppose the public could be served more economically?

There is nothing to be gained by creating a false impression among your farm readers as to the large packers. The stock-raiser, I honestly believe, is getting his full share now and should bear his responsibility for the high prices for meat—not throw it all onto the packer. I have not particular interest in the matter, only I think you ought not to publish unfair editorials. See Review of Reviews, March, 1910, "Our Beef Supply."

LOUIS G. BEERS.
 Trenton, N. J.



The FARMERS' LOBBY.

By Judson C. Welliver

ONE of the great works of our Department of Agriculture is the introduction from other countries of plants, grains, trees, etc., which are calculated to diversify and increase the value of the output of our soil. It must be borne in mind always, however, that this introduction of things from other soils and climates is accompanied by very real danger of bringing pests which may do great damage. We brought some highly desirable cottons from Central America, but with them came the boll-weevil. In Central America the weevil is comparatively harmless because its natural enemy, the Guatemalan ant, lives there, and by dint of diligently feeding off the wicked weevil, keeps him in reasonable subjugation. Unfortunately, we imported the weevil but didn't bring the ant along, with the result that the weevil has had a perfect picnic in our cotton-fields, with no pestering ant to worry him. We sent off after the ants, but they have made poor out at living in our climate.

Likewise we imported the Russian thistle with some Russian wheat. The other side of the picture is presented when we look into the fig industry in California. The figs were willing to grow, but a scale appeared on them and it was necessary to have a certain parasite to devour that scale. The department hunted far and wide to find the right beast, and finally, from the Volga in Russia, brought a "lady bug" which after much effort was introduced in California and eats the scale.

Nobody better than the department authorities realizes the necessity of great care in introducing plants and insects from abroad. Many cases have enforced that realization, and legislation is now pending which designs to clothe the department with necessary powers to guard against the commercial introduction of diseases and pests. After careful inquiry among the scientists and administrators at the department, the suggestion is ventured that farmers and orchardists ought to interest themselves in behalf of the bill (H. R. 23,252) introduced by Mr. Simmons, of New York, and at this writing pending before the House committee on agriculture.

There has been some opposition to this bill, backed by nurserymen. I believe that the opposition will not be pressed unduly when the facts in the case are fully understood. The committee is altogether likely to report the bill, according to leading members; but some of the extreme opponents have gone so far as to threaten a vigorous fight on the floor of the House that may keep the bill from passage.

Why the Department Backs the Bill

The bill consists of fourteen sections and gives the Secretary of Agriculture power to issue permits for the introduction of foreign nursery stock, bulbs, etc. Without the necessary permit such importations may not be made. On arrival, the stock shall be inspected by experts of the department and it may not be transported in interstate commerce till it shall have been certified to be free from disease or insect pests.

Section 8 of the bill is the one to which objection has been made. It follows:

Section 8. That whenever it shall appear to the Secretary of Agriculture that any nursery stock or other described articles or variety of fruit grown in an infested district outside of the United States is being, or is about to be, imported into the United States or the District of Columbia, and such nursery stock or such variety of fruit is infested by any seriously injurious insect or disease, and which insect or disease is liable to become established in the United States, he shall have authority to quarantine against any importations from said district and prevent the same until such time as it may appear to him that such disease or insect has been exterminated in the country or district from which such nursery stock or variety of fruit is being, or is about to be, imported, when he may withdraw the quarantine.

The secretary is likewise empowered to establish such quarantine against transportation in interstate commerce of nursery stock from infested districts in this country.

When the Simmons bill came before the House committee it developed that some of the department authorities had been instrumental in securing its preparation and introduction, because of their knowledge of the menaces to American orchards. One of the particular reasons was the recent tendency to spread of

the brown-tail moth and the gipsy-moth, which have done so much devastation in sections of New England. In the last two or three years the department has received reports from more than a half-score of states of the appearance of the brown tail, apparently as a result of importation with nursery stock from Europe. This has caused the most serious alarm, and the Simmons bill has attracted support from many parts of the country.

Close watch is being kept nowadays by the agricultural officials on the orange-fruit worm which has done great damage in some sections of Mexico. It moves into the young fruit and lays its eggs, which hatch into a colony of maggots. California orange-growers have been concerned about the possibility of its introduction. Thus far, although it has been found in some parts of this country, it has not appeared in the orange-growing regions, for the obvious reason that taking Mexican oranges to Florida or California would be carrying coal to Newcastle, and nobody has done it. Yet there is always the danger that somebody will do it, in the course of experiments or by accident. The Simmons bill would be of special efficacy in guarding against introduction of just such an insect as this Mexican orange pest.

Where the Bill Irks the Nurserymen

The nurserymen, however, appeared before the committee to protest against the measure. They said they were perfectly willing to be subjected to a proper inspection of their imported stocks, but they could not agree to Section 8, as quoted above. In many cases, they explained, they are compelled to place orders abroad for stock, four and five years before the time of delivery, as the stock must be grown for them. They point out that if the district from which they have ordered stock should be quarantined long after the order was placed, they would be unable to get their orders filled. Their argument is that a proper inspection and disinfection at the port of entry ought to be ample to protect this country. There is already such inspection, through cooperation of the Treasury and Agricultural Departments.

To this argument answer is made that in actual experience this protection has been found inadequate, as indicated by recent importations of pests from foreign countries, notably France. The department authorities insist that the power to establish quarantine has been of great value in protecting against diseases of animals, and that it is just as logical and necessary in the case of plants. The arguments before the committee certainly seemed to make a good case for the bill. The hearings have been printed, and people interested in the subject can get the document, with copy of the bill, by writing to Representative Charles F. Scott, chairman of the committee on agriculture, at Washington.

A National Apple Inventory

Apropos of this problem of protecting American orchards and forests, it is promised that the new census is going to provide some statistics which will be of great value to fruit-growers. In the last two or three years there has been much protest that the statistics on these crops are misleading and often worse than useless. The allegation has been made that the national apple crop is not nearly keeping up with the demand, and the statistics of production seemed to bear out this view. But the experts say that the statistics of production for the last twenty years have been very unsatisfactory. The census of 1890 has been the starting-point for many of the current computations, and it is now accepted that that census gave a very misleading view of the case. In 1890 the census-takers made the mistake of computing acreages in orchards. That resulted in putting in many worn-out orchards on the basis of acreage, in which there were actually very few bearing trees, thus giving the impression that the country was producing a much larger yield of apples than the facts warranted; and because in many years since then it has been apparent that nothing like so large a yield was harvested, the impression has gained ground that there has been a great loss in the crop. The last three years have been bad apple years, but the authorities do not believe that in general there has been so much loss of the apple

production as many people, comparing with the 1890 census figures, have assumed. At any rate especial care is being taken this year to get accurate data. People who study the figures will get some valuable pointers on profitable investments in production of the fruits that are indicated as likely to be most in demand in the coming years.

To return to the various pests that have been or are liable to be imported from abroad. The department people believe that the average small orchard-owner is unduly fearful of the expense involved in protecting his trees. Many owners of small orchards have assumed that spraying, etc., is too expensive and have given up the idea of caring for their trees, with the result that there is an unfortunate tendency to abandon orcharding to specialists who put in great areas. The government experts think this is a mistake. They point out, for instance, that the San Jose scale, which has been dreaded all over the country, and is widely disseminated, is now kept in subjugation by a single proper spraying per year. The department has developed sprays, apparatus, etc., and sends men out to the orchard districts to instruct the people in their economical use. The result is that the San Jose scale is no longer seriously feared by commercial orchardists who know all about how to handle it. The small-scale fruit-grower need not be frightened at the notion that it is a big, expensive task to protect his few trees, because, in fact, it can be done very inexpensively and quite as effectively by him as by the owner of a great orchard.

Considerable importations of potatoes to this country in the last year or two have given concern, in like fashion, lest some very dangerous diseases of the potato, which have been causing havoc in Ireland and England, might be brought here. European countries have sent us, with importations of pine seedlings, some diseases of the pine that have caused concern, though they are believed to be under control now.

What Happened to the Japanese Cherries

Within the last year the Japanese government graciously donated some thousands of wonderfully beautiful Japanese cherries to this government, to be used in beautifying some of the driveways of Washington. The gift was made as a personal compliment to Mrs. Taft, who had been interesting herself in developing certain especially attractive drives. When the cherry-trees came the inspecting officials discovered that they were infested with a most dangerous pest which, once planted in this country, might destroy the entire cherry crop.

It was a right delicate business. The Tokio government had presented those trees to the wife of the new president, and to make kindling of them was highly ungracious. Well, the agricultural authorities wisely decided that the first thing to be done was to burn the dangerous trees, and the next job would be to let the State Department explain it all to the Tokio government. There has been broad intimation that the State Department was distinctly annoyed over the necessity of conveying to His Imperial Highness of the Rising Sun that his gift had been used for a bonfire; but it was delicately broken to the Japanese, and thus far they haven't grabbed our islands or blown up San Francisco, and it is confidently believed they will restrain themselves.

In the case of those cherries the menace was exactly the same as in that of the boll-weevil. The insect which came along with the gift cherries is a native of Japan. It would kill all the cherries in the islands in a decade, but for the fact that Japan, by one of those interesting schemes of compensation so often presented in nature, is also the home of this insect's deadly enemy, another insect that eats the bug that eats the cherries. Now, suppose we got the anti-cherry bug, but couldn't induce the anti-anti-cherry fly to live here? We would lose our cherries, and it was a longer chance than the department wanted to take.

Such incidents are constantly rising, which seem to make it altogether desirable to give the Department of Agriculture the fullest powers to protect this country. The activities of that department in hunting up and bringing to us useful plants from all over the world reasonably assure that we will not be made the victims of any excessive zeal directed to the establishment of a know-nothing flora on this continent.

The Housewife's Club

EDITOR'S NOTE—Most every woman has originated some sort of a device or convenience to make part of her housework easier and less burdensome, and to all who have, we would ask that you write and tell us about it. Aside from making a little pin-money for yourself, you will be helping others, and this is what "The Housewife's Club" is for. We will give \$2.00 for the best description and rough sketch of an original home-made household convenience or labor-saving device, and \$1.00 for the next best, or any that can be used. We will also give 25 cents each for good kitchen hints and suggestions, also good tested recipes that can be used. All copy must be in by the tenth of July. Contributions must be written in ink, on one side of the paper, and must contain not more than 250 words. We would suggest that contributors retain copies of their manuscripts, as no contribution will be returned. Address "The Housewife's Club," care of Farm and Fireside, Springfield, Ohio.

The Genuine BAKER'S Breakfast Cocoa



with the *delicious natural flavor* and the rich red-brown color characteristic of this high grade cocoa is made only by

Registered U. S. Pat. Office
Walter Baker & Co. Ltd.
Established 1780 DORCHESTER, MASS.

If You Dread WASH DAY—Read This—

You can do in one hour, what now requires a whole day. 1 hour of easy turning of a wheel while you sit. Clothes will be whiter will last longer. Use an

O. K. Washer

Large tub of red cypress, will never warp, cannot wobble. Lid is steam-proof, keeping water hot. No strength needed to operate. Simple Roller Gearing makes it easy for child to operate. Our guarantee with each.



H. F. Brammer Mfg. Co.
1452 Rockingham Road
Davenport, Ia.
Write For Free Book

THE BEST LIGHT

Gives 500 candle power. Casts no shadow. Costs 2 cents per week. Makes and burns its own gas. Over 200 styles. Every lamp warranted. No dirt. No odor. No grease. Agents wanted. Write for catalog, now.

THE BEST LIGHT CO.
212 E. 5th St., Canton, O.

Berry-Puffs

ONE fourth of a cupful of butter, one half cupful of milk, one half cupful of sugar, one cupful of flour, one egg, one teaspoonful of cream of tartar, one half teaspoonful of soda. Put one tablespoonful of berry sauce into a cup, fill the cup half full of batter and steam for forty minutes. Serve with whipped cream. This makes six puffs.

E. M. G., Vermont.

Fluid for Cleaning Carpet

ONE cake of white soap, two tablespoonfuls each of ammonia, borax and sal soda. Put on the stove and boil until dissolved; then add soft water enough to make three gallons. When cool apply to the carpet with a stiff brush, rubbing until the lather is rubbed into the carpet. Rinse with a cloth wrung out of clean water.

Mrs. B. B. B., Ohio.

A Chair Swing

IF YOU happen to have an old chair, minus legs, that you are about to consign to the rubbish-heap, this suggestion will surely prove helpful, for the old chair can be made into a very comfortable swing. To the sides of chair attach heavy rope as shown in the illustration, bringing the ends up and tying them securely on a strong branch of a tree.

The children will be delighted with the swing, and to prevent any possible



An Old Chair Converted Into a Swing

falls, it is well to attach a strap to the side so that the child can be tied in securely.

Mrs. A. C. B., Illinois.

Home-Made Fruit-Picker

THE illustration below shows very plainly just how I made this useful fruit-picker. Take heavy copper wire, bend it back and forth so that it resembles the letter "M." Then attach it



to the longest pole you can find. Make a bag of heavy denim or burlap large enough to fit the wire frame and sew it firmly together to form a sack or deep pocket.

You will find you can reach the very highest branches without asking the men folks for assistance.

Mrs. H. S. M., Pennsylvania.

Some Good Hints

Wring chamois out of soapy water without rinsing. When it dries, instead of being stiff and hard, it will be nice and soft.

To boil eggs that are cracked, wrap them in a piece of white muslin and there will be no danger of them oozing out in the water.

A little flour spread over the top of cakes before they are iced will prevent the icing from running off.

Mrs. E. C., Ohio.

If you want milk to sour quickly, put a slice of bread into a jar of sweet milk and place near the range.

Kitchen paint invariably has a dull, shabby look from the frequent cleaning that is necessary. The use of soap increases the difficulty, especially if the paints are varnished. The best plan is to boil a pound of bran in a gallon of water for an hour, then wash the paint with bran-water, and it will not only be kept clean, but it will be bright and glossy.

M. E., Canada.

A pinch of mustard added to the flour used to thicken the drawn butter sauce for asparagus or stewed carrots adds a fine flavor.

Miss E. A. R., Maryland.

Axle-Grease on Linen

TAR and axle-grease on white cotton and linen goods may be removed by using soap, oil of turpentine and water, each one applied in turn.

For colored cottons and woollens cover the spot with lard, rub with soap and water, and let stand for some time; then wash alternately with oil of turpentine and water.

B. S., Minnesota.

Hints for the Sick-Room

When a subdued light is necessary in a sick-room, place the handle of a palm-leaf fan in a vase near the lamp. This is an easy and effectual shade for the patient's face.

Should bed-sores appear on the heels of your patient, make a ring of cotton to rest the heel on to keep the sore place from pressing on the bed.

A good deodorizer for a sick-room is equal parts of ground cloves and cinnamon put on a hot shovel. It leaves an agreeable odor in a room.

C. E. H., Massachusetts.

A Place for Garbage-Pails

INSTEAD of keeping my garbage-buckets in the kitchen, I had the man of our house put up a device for holding the pails as shown in the illustration given below. The post is conveniently near the back door of the kitchen, and the garbage, hung in the pails on the post, is out of the reach of the dogs and chickens. It is well to cut two grooves in the cross-board for the pail-handles to fit in. The large board on the top of the post prevents the rain falling into the garbage.

S. E. C., North Carolina.

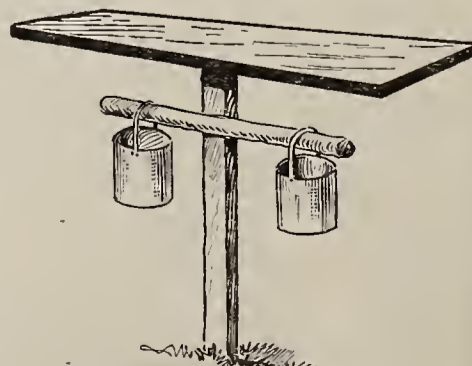

A Device for Holding Garbage-Pails

Yeast Requiring no Starter

BOIL one ounce of hops in two quarts of water for half an hour and strain. When lukewarm add one half cupful of brown sugar and one tablespoonful of salt. Mix a scant pint of flour with some of the hop-water and gradually add all the water. Keep this batter in a warm place for three days. Stir frequently while it is working. On the third day add one and one half pounds of potatoes boiled and mashed. Let stand another day, then strain and it is ready for use. The yeast will keep four or five months. Only one cupful should be used to eight loaves of bread. Bread made with this yeast is delicious.

Mrs. T. B., California.

Shrinking Braid

IT is best to shrink cotton wash braid before using it. Put it in rather hot water for a few minutes, let dry slightly, then press with a warm iron. It will not draw when the garment is washed.

Mrs. J. L. R., Ohio.

A Kitchen Dumb Waiter

THIS elevator is only one foot square and is placed against a partition wall over the edge of the cellar. It contains four shelves, the top one going below the level of the floor when let down. The shelves are held in place by means of tin strips ten inches wide, fastened to the shelves on both sides. The box or chute is made of one-by-twelve-inch boards extending three feet above the floor and three feet below. If desired, a screen door may be attached to the ele-

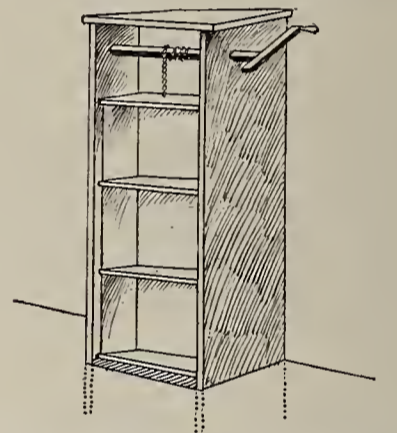

A Home-Made Practical Kitchen Elevator

vator to keep out flies. I find this elevator so convenient for lowering milk and butter into the cellar.

Mrs. J. R., New Mexico.

Cheese in Blankets

AN EXCELLENT way to utilize left-over bread and cheese is to cut bread in squares measuring two or three inches. Brush with melted butter, grate over with cheese and sprinkle lightly with salt. Add another slice of bread sandwich fashion. Beat the yolk of an egg, add a little milk and fry in butter to a golden brown.

Mrs. G. L. S., New York.

To Destroy Insects on Plants

THREE and one fourth ounces of quassia chips and five drams of larkspur-seed. Boil these together in seven pints of water until the decoction is reduced to five pints. When the liquid is cooled, it should be strained and used with a watering-pot or syringe, as most convenient. This is an excellent liquid and it will not destroy the plant.

Mrs. E. P. W., Maryland.

A Substitute for Sugar

IF YOUR husband keeps bees, and has an extractor with which to shake the honey from the cells, these suggestions of mine will appeal to you. Oftentimes when making a plain bread-pudding I vary it by using honey instead of sugar for sweetening. I also make cookies with honey, using one cupful, one cupful of sour cream, one egg, a scant teaspoonful of soda, one teaspoonful of salt, a heaping teaspoonful of cinnamon and as much flour as is needed to mix and roll out. The cookies are better the second day. When making the pudding, I heat the honey until it is thoroughly warmed—and stir it in after the eggs. I serve the pudding cold, as it is not good while warm.

L. H., North Carolina.

Crisp, Golden-Brown

Bits of Corn

Post Toasties

Deliciously flavored—

Wholesome—

Comforting—

Ready to serve from the package.

With cream or fruit it is a delightful food for Old and Young.

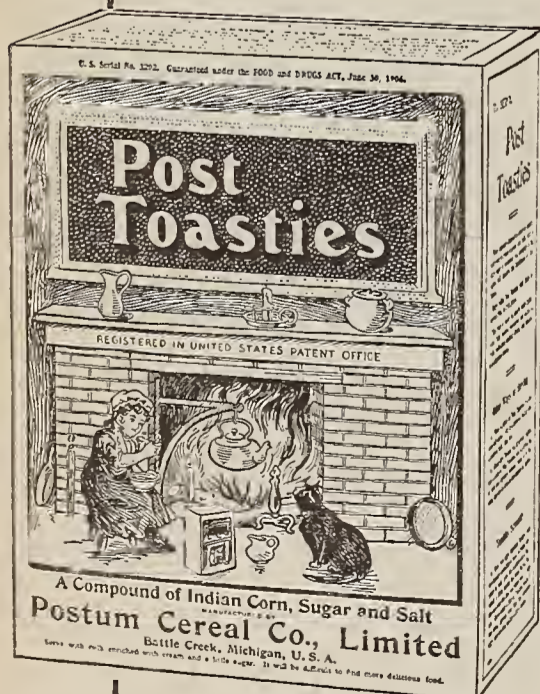

"The Memory Lingers"

Packages 10 cents and 15 cents. Sold by Grocers.

Postum Cereal Company, Ltd., Battle Creek, Mich.

The City of Strange Romance

By Newton A. Fuessle

Illustrated by R. Emmett Owen



"She sat musing and motionless"

HOLLY FOSTER climbed the stairs to her little third-floor room, lit the gas, let a sigh escape which denoted but little of the volume of tiredness in her soul, smiled wanly at her handsome image in the

cracked mirror and pulled the long pins out of her hat. She had paused for a lonely dinner at a neighboring café on her way home from the office, to gaze with a wondering curiosity at the chorus girls whose faded finery and melancholy eyes bore evidence that they were out of jobs, and to nibble with little appetite at Irish stew and her leathery sample of a baked apple. There was something cheerless about the eating-house which cast the picture of meal-time at home, back in the little Ohio town, upon the retina of her fancy and brought even a bit of homesickness for the boarding-house up on One Hundred and Thirty-Ninth Street whose heavily-powdered landlady and uncongenial personnel she had deserted with a grateful sigh after a three weeks' trial.

When Holly lighted the gas-jet and the dwarfish room bounded into view, she saw on her chiffonier a letter from her mother. A sort of heaviness came into Holly's eyes as she read the simple sentences from home, but her lips straightened into a firmer line.

"No, mumsie," said the girl softly, addressing a picture hanging in a frame on the wall and answering one of the questions in the letter. "I can't go back home—just yet. I can't give up and quit. I've just got to succeed. But, oh, how I'd love to be there instead of here!"

Holly threaded a needle and juggled a dozen deft stitches into the torn finger of a glove. Presently she sank into a chair by the type-writer. For ten minutes she sat musing and motionless. Then her fingers began drifting over the keys, dipping and rising slowly as labored sentences began to appear on the sheet of paper.

Thus had she spent the evenings during the passing weeks, after her day's work as stenographer to a lawyer on William Street, save when the friendly landlady paid her a visit or when she slipped over to a neighboring theater to peer down at the players from a lofty perch in the topmost gallery with the interesting little manicure girl who lived in the room above hers.

Holly had left her home in Ohio to invade New York, flushed with an inordinate ambition after she had sold a few contributions to magazines, and this had been her envoi in the town's weekly *Clarion*: "Holly Foster, our brilliant young journalist, will leave on Monday for New York City, where she will continue her promising career in the world of letters. Her brilliant fiction has already attracted the attention of the Eastern editors and her success is assured."

And, ah, how many a bucolic scribe has written a similar prophecy on the departure of youths and girls for New York! Little does the party of country folk which accompanies the departing one to the station realize that New York is not entirely a blaze of theaters, cafés and success. Little does the country editor know that there are rows upon rows of bleak and hopeless rooming-houses whose cramped and dwarfish bedrooms afford cheerless shelter for those armies of young men and women from the West who keep deferring a defeated home-going with the heavy-hearted hope that they will at last see success.

New York had torn swift breaches into Holly's little hoard, and hope had at length been transformed into her changeling sister, despair, as Holly traveled the route which many a brave young soul had traveled before her. Her clicking type-writer had continued its bombardment of the fortresses of magazinedom like a miniature and impotent machine-gun, but her offerings had invariably come fluttering back to her, undesired and rejected. And slowly her spark had grown dim. Confused by the monster city, sickened by the display of great wealth, dazzled by the brilliancy of

the success of others, the little cunning she had acquired at home seemed to ebb steadily and relentlessly.

It is not an easy thing for the new-comer to write of New York. It takes time for the revolving millions to be seen clearly by the eye of an alien. And as Holly began to realize that this was true, she strove once more to draw her material from the town a thousand miles to the west, only to realize in turn that it had grown dimmer and vaguer until now it seemed but the lingering recollection of a dream.

And so, hesitating to admit the defeat which returning home would have denoted, she strove anew to gain a foothold by taking a twelve-dollar-a-week job in the lawyer's office. But in the evenings her ambition would smolder anew and she would resume, as to-night, her chase after illusions which had grown so hopeless and so grievous.

To-night, as she sat thinking, she suddenly became aware that she was listening to voices which came from the room adjoining hers. She did not mean to be an eavesdropper, but as the partition was thin, the voices of her neighbors sounded so distinctly that she had no alternative.

"I tell you, old man," one of the two young men was saying, "this infernal town is no place for a white man. The first bunch of money I get I am going to beat it. It's one thing to write letters home about the advantages of living in the heart of the theatrical district and brushing elbows with celebrities and weaving your way down Fifth Avenue with the swells, but it's another thing to have every article you possess, except the clothes on your back, in soak, to be afraid to accept a dinner date in Brooklyn or the Bronx for fear you won't have a clean shirt or carfare when the time comes and to count it a rare luxury to be able to sit down to a stack of buckwheat-cakes in a quick-and-dirty lunch-house."

"Don't—I beg of you!" moaned the voice of the speaker's companion. "The ambrosial taste of a plate of cakes would make me lose my reason after three days of sneaking in and out of free-lunch stations. You've certainly got the right angle on the situa-



"She slid the envelope under the door"

tion, and, believe me, I want to get back home. But we stand a fine chance to pull off the big exodus. The common carriers aren't engaging in a rate war, and it's too beastly cold to hike."

Holly started. The picturesque recital of her neighbors' woes affected her strangely. The telling arraignment of the city, their longing for home, told her that her own sentiments were not her property alone. She had passed the youths occasionally in the hallway, and their polite bows had given her never an intimation that they were traveling hard paths. In great surprise she waited for the voices to continue.

"I haven't had a bite to eat since morning," the first speaker went on after a moment. "And I'm so sick of grazing on the dill pickles and stale rye-bread of the taverns that I can hardly gulp them down."

"I share your rebellious attitude," came the answering voice.

"I dragged myself all the way down to Park Row this afternoon," spoke the other, "only to find out from the city editor of nearly all of the New York papers, that there wasn't a chance on earth to land a job."

"I spent my last quarter to go over to Jersey to-day," came the reply, hunting a job selling lamps for the general Electric. I've struck for fifty-odd jobs in the last week, all the way from hauling coal to writing ads., and nobody will have me."

"I nearly swooned this evening," declared the other.

"How was that?"

"Well, I passed a chop-house and was overcome by the odor of steak."

Holly trembled. She had never in her life gone hungry. The story of the misfortune of her neighbors had been hammered more deeply into her consciousness by the blows of the grimly humorous method of the telling. Suddenly a quick resolve flashed into her thoughts. She seized her purse and opened it. There was a five-dollar bill, and three ones. She took out the five, and closed the purse. Three dollars would keep her for the rest of the week. She put the five-dollar bill into a blank envelope and glided noiselessly out of her room and down the hall to the door opening into her neighbors' room. She slid the envelope under the door and noiselessly crept back to her room. A look of satisfaction flew into her dark eyes. She stood at sharp attention, her ear bent toward the wall, her handsome face radiant with happiness.

Soon afterward came a low exclamation from one of her neighbors. Holly was straining every nerve to hear what was said.

"Say, I want to know if you've been praying. Have you?"

"What for?"

"Money, wealth. Have you?"

"Perhaps," came the confession.

"Well, you don't have to be ashamed of it! Your prayer has been answered. I hold in my hand a nice new five-spot."

It was several seconds before the other man cried suddenly: "Great Scott!"

"Now don't ask any fool questions," corrected the other, "but tumble into those clothes of yours and we'll have the juiciest steak in town."

When the two youths had flung out of their room and down the stairs, Holly Foster took up a pile of manuscript which lay on the table beside the typewriter and began to read. There was much similarity in what she had been trying to write for the past weeks. Always, she had striven to build into the parallel lines of type-written sentences certain impressions of New York—the coldness of the friendless city, the impassive faces of strangers, a tugging longing for home. And somehow as she had written thus the effect of her task had been to enfeeble her resolution to continue her fight and to crowd past besetting odds to success. The cold, forbidding picture she had been drawing had gradually chilled her ardor to achieve success, had rendered more and more grievous her monotonous toil at the law office.

But to-night, all of a sudden, the city's gloomy picture of life had undergone a change. She became vaguely conscious that a radical modification had entered her point of view. She perceived with vision strangely clarified that the lines of the written pages before her seemed no longer to ring true. Her brain filled with a surprised wonder; she did not understand. She was not aware that the miracle which had befallen her neighbors in the next room through her act of generosity had rebounded into her own life, regenerating the spark which had grown dimmer and dimmer within her, but whose warmth was once more caressing her soul and rebuilding, by some strange magic, the city surrounding her in softer lines and warmer tones.

And the next morning, when Holly walked down the street to her place of business, a song was rippling through her brain and, somehow, she was happier than she had ever been since she arrived in New York. And as she sat drumming her type-writer in the towering office-building her soul and fingers sang.

It was because her ears had been surprised the night before by a strange story of hunger and because she had slipped an envelope containing a five-dollar bill under the door of her hungry neighbors' room.

As the hours of the day flew by, Holly was vaguely aware that her thoughts were oftenest upon a certain young man. Hardly half a dozen times had she ever seen him, only in passing glimpses on the stairs or in the hallway of her house. It was ridiculous that she should be thinking of him so much to-day, she said to herself, yet, always, would her thoughts return to him. Then, too, there kept recurring the strange things which he and the other youth had said last night, which had drifted through the walls to her ears and made her reach for her purse.

What happened during the next few days has little to do with this story; but on Saturday night, when Holly returned to her room, she noticed an envelope on the floor by the door, and, on opening it found that it contained a five-dollar bill. Accompanying the money was a sheet of paper, bearing the following unsigned communication: "With many, many thanks and two hearts full of best wishes."

She caught her breath and her face flushed. The return of her loan was a plain indication that the youths knew who it was who had slid the money under their door. She felt very foolish. Had some one seen her steal down the corridor on her unusual errand? Or was the return of the money merely the result of a surmise that it had been she, based on the knowledge that the sound of their voices could not have penetrated into any other neighbor's room? But, whatever the real facts were, how could she ever bear to face the young men again after what she had done? What



"I haven't had a bite to eat since morning"



"She noticed an envelope on the floor"



"Somehow, she was happier than she had ever been since she arrived in New York"

50ct. SHEET MUSIC
 15 CTS. EACH, POSTPAID
 SONGS—Words and Music for Piano or Organ

Rainbow	Carry Merry Harry, Big Hit
My Pony Boy	I've Got Rings on My Fingers
Red Wing	Down in Jungle Town
Just Some One	I Wish I Had a Girl
Red Head	Yip-I Addy-I-Aye
Star of the East	By Light of Silvery Moon
Oh! You Kid	Sweet Bunch of Daisies
Senora, A Dandy	Silver Threads Among the Gold
Snarty, Kid Song	My Wife's Gone to the Country
Baby Doll	That's What the Rose Said to Me
Dreaming	Put On Your Old Grey Bonnet
Are You Sincere	Way Down in Cotton Town
No One Knows	Isn't That Enough For You
Honey Boy	I Remember You Napsnee
Daisies Won't Tell	I'm Bringing Up the Family
Molly Lee	Be Jolly Molly, March Song Hit
Beautiful Eyes	Lonesome Taffy
Always Me	The Land of To-Morrow
That Italian Rag	Cubanola Glide, Great Hit
Garden of Dreams	I Love My Wife But Oh You Kid

INSTRUMENTAL—Music for Piano or Organ

Kiss of Spring, Waltz	Wild Cherry, Rag
Sicilian Chimes, Recerise	Frog Legs, Rag
Let Er Go, March	Love Sparks, Waltz
Rainbow, Two Step	Moon Winks, Three Step
Star of Sea, Recerise	Triple Leaf, Rag
Morning, Co. Bara Dance	Beautiful Star of Heaven
Turkey in the Straw	Sen Hur Chariot Race
Red Wing, Two Step	Kerry Mills Barn Dance
Red Head Rag, A Hit	College Life, Two Step
Curly, Two Step (New Hit)	Rose Song, Recerise
Burning of Rome, March	Princess Royal, Caprice

Our Music is the same—every particular—no you purchase in any Music store—the only difference being the price.

THE MYREX COMPANY, 248 West 36th Street, NEW YORK
 "The Cheapest Music House on Earth"
 Send 2c. Stamp for "Money Saving" Catalog

would they think of her conduct? She had been a conscious and deliberate eavesdropper, and her neighbors knew it. Thoroughly disturbed, Holly spent an uncomfortable evening. She hated herself for listening and reproached herself for her generosity. She saw before her the fine face of the Southerner. What feelings were surely disturbing him, she mused, now that he looked back and realized how he and his companion had accepted the patronage of their girl neighbor!



"Picking up a newspaper, she saw something which paralyzed her"

Her eyes clouded with tears, and she called herself a little fool and made up her mind to move out of the place at the end of the week. Yet the disturbance, Holly felt over the discovery of the money under her door faded into insignificance when she made a discovery on the following day—Sunday. Picking up a newspaper, as she was eating a lonely dinner in a French restaurant on Sixth Avenue, she saw something which paralyzed her. She caught her breath with a gasp, the blood fled in a wild ferment to her face and the paper went fluttering to the floor. An obliging waiter was at hand to recover it for her, but the anesthetic of the sight which had confronted her for a brief moment rendered her eyes unseeing and she could hardly distinguish a blurred vision before her.

a moment before the mirror to look at herself and hurried forth. The newspaper fortress that she proposed to storm was not far away, and a few minutes later she was promptly ushered to the editor's private office.

At length, very slowly, a few details came creeping out of the dancing page before her. She beheld, for one thing, the name "Holly Foster" in heavy, black-faced type and saw her own face smiling back at her from the page. Also, jammed into the lower corner of the page was the interior of her little room.

There was a sharply-defined look of anger on Holly's face as she walked into the office. But when she beheld the man who had risen to greet her, the stern expression scattered into a look of utter confusion and the words on her mouth fled in a gasp of bewilderment.

Holly did not finish her dinner. She could not. Her soul was swamped in wild confusion, and at last the confusion gave way to rage. Enraged girls generally weep, and Holly wept brokenly as she made her way back around the corner to her rooming-house.

"I am glad to meet you, Miss Foster," said the gentleman, extending his hand, and receiving a very limp one of hers. "You came to demand an apology."

An hour later she dried her eyes, spread out the horrible sheet of the illustrated Sunday section of the newspaper and began very grimly to read. And there, hammered into place by the big press of a harsh and heartless metropolitan daily newspaper, stood a strange story. The story recited how two youths, out of work and money, had rehearsed the woes which beset them one night in their hall bed-room. Faithfully the writer had set down the things the two young men had said and how a girl occupying the adjoining room, had overheard the recital, how her heart had been touched by the dialogue and how she had stolen down the hallway and projected five dollars under the door of her hungry neighbor.

The speaker was strangely young, and was the self-same young man whose recital of hunger and failure had stirred Holly's soul and opened her purse!

It was a great story, as stories are reckoned by editors, in that brutal game of newspaper-making. It was strong in human interest, that fetish of nervous spectacled men at the desk, who send reporters' salaries soaring when they bring in human interest pelf, who feed on the hearts of the city's four million. But to Holly, crushed by the uncanny truth of the printed story before her, had been dealt the hardest blow of her life.

"Yes," she found strength to respond, "I—came—for an apology."

She did not go to work the next day. She could not bear to face her employer, certain that he had seen the newspaper, and foreseeing the smile with which he would refer to her methods of putting money into circulation. Her imagination reached out, and already Holly could see the smiles of passers-by on the street, who readily recognized her as the girl whose picture was in the paper. Ah, she would have to leave, would have to flee this terrible city, its jeers, its laughter!

"If you will let me, I think I can give you an explanation which will make an apology unnecessary," rejoined the editor.

But before she took up her flight somewhere, anywhere, she would confront the editor who was responsible for the horrible story and speak her woman's mind. She donned her hat and coat, paused for

"I'm going to tell you something, Miss Foster," began the young man gently, "and when I get through you will be better able to judge my conduct. I must go back a little bit, for I want to start at the beginning. I have lived in a score of New York rooming-houses in the last year. It is my method of securing material for fiction and newspaper articles. A few weeks ago I moved into the house where you are living. In talking to the landlady and to the little manicure girl who lives there, I learned that you came to New York to write, but were not succeeding. But I realized that certain combinations of circumstances would be sure to lead to your success. There was something about you which strongly interested me, if you will let me say so. So I set about to devise a plot calculated to help you work out your ambitions. I knew that a startling piece of publicity, such as was furnished in my story about you yesterday, would throw your name into the lime-light so that anything you might write would go strongly if published. You had submitted several pieces of writing to this newspaper, all of which have been rejected, not because they were poorly done, but because the name of the writer was unknown. I was impressed by their fine quality, but could not use them.



"Yes, I—came—for an apology"

moved back to my club," he added. "But may I call and see you—sometime soon?" "If you'd like to," she answered softly. A moment later, Holly emerged into the rush and roar of lively Broadway, into the city of strange romance, and, somehow, she was very happy. A singularly new and different city it seemed to her now, and, had she been less bewildered, she might have realized that in a chaotic office hard by sat a young man from the far South to whom the events of the past week had a deeper meaning by far than any succession of episodes which had affected him since he had come to New York.

Watch Fob Given to Bicycle Riders

Send your dealer's name with 4c postage and we will mail this handsome fob. Also catalog illustrating and pricing our high-grade Indianapolis G & J TIRES. Admitted by bicycle manufacturers and riders to be the best made. Wear longest, ride easiest and are most convenient to repair. G & J TIRE CO. Indianapolis, Ind. Address Bicycle Tire Dept.

MEET THE HIGHER COST OF LIVING WITH A FULLER PURSE

Use methods that bring big returns, and add to your income in ways that don't add expense. These new books tell you how to do it.

- How to Keep Bees for Profit** By Dr. D. E. LYON, Bee Expert. The simple essentials. \$1.50 net, by mail \$1.61
- How to Keep Hens for Profit** By C. S. VALENTINE, of the New York Tribune Farmer. Cloth, \$1.50 net, by mail \$1.61
- Manual of Practical Farming** By JOHN MCLENNAN. Illustrated. Cloth, \$1.50 net, by mail \$1.61
- Manual of Gardening** By L. H. BAILEY, the cyclopedic authority. Full, profusely illus. \$2.00 net, by mail \$2.14

Order of any bookstore or by mail from THE MACMILLAN COMPANY Sixty-four to sixty-six Fifth Ave., New York

Salesmen Wanted

Traveling Salesmen earn from \$1,000 to \$10,000 a year and expenses. Over 700,000 employed in the United States and Canada. The demand for good Salesmen always exceeds the supply. We will teach you to be an expert Salesman by mail in eight weeks and our FREE EMPLOYMENT BUREAU will assist you to secure a good position. We received calls for Salesmen from over 5,000 firms last year and could not fill our orders. Hundreds of our graduates who formerly earned \$25 to \$75 a month have since earned from \$100 to \$500 a month and expenses. Hundreds of good positions open for the spring rush. If you want to secure one of them or increase your earnings, our free book, "A Knight or The Grip," will show you how. Write or call for it today. Address nearest office. Dept. 429 National Salesmen's Training Association Chicago, New York, Kansas City, Minneapolis, San Francisco, Atlanta

FEED CHILDREN On Properly Selected Food. It Pays Big Dividends

If parents will give just a little intelligent thought to the feeding of their children the difference in the health of the little folks will pay, many times over, for the small trouble. A mother writes saying: "Our children are all so much better and stronger than they ever were before we made a change in the character of the food. We have quit using potatoes three times a day with coffee and so much meat. "Now we give the little folks some fruit, either fresh, stewed, or canned, some Grape-Nuts with cream, occasionally some soft boiled eggs, and some Postum for breakfast and supper. Then for dinner they have some meat and vegetables. "It would be hard to realize the change in the children, they have grown so sturdy and strong, and we attribute this change to the food elements that I understand, exist in Grape-Nuts and Postum. "A short time ago my baby was teething and had a great deal of stomach and bowel trouble. Nothing seemed to agree with him until I tried Grape-Nuts softened and mixed with rich milk and he improved rapidly and got sturdy and well." Read "The Road to Wellville," found in pkgs. "There's a Reason." Ever read the above letter? A new one appears from time to time. They are genuine, true, and full of human interest.

A Corner of Wit and Humor

Taking Reasonable Precaution
 A SCOTSMAN with a toothache went to a dentist. The dentist told him he would only get relief by having the tooth out. "Then I must have gas," said the Scotsman. While the dentist was getting it ready, the Scot began to count his money. "You need not pay until the tooth is out," said the dentist somewhat testily. "I ken that," said the Scotsman, "but as ye're about to mak' me unconscious, I jist want to see hoo I stan'."—Brooklyn Life.
 A TEACHER in a big elementary school had given a lesson in an infants' class on the Ten Commandments. In order to test their memories, she asked, "Can any little child give me a commandment with only four words in it?" A hand was raised immediately. "Well?" said the teacher. "Keep off the grass," was the reply.—Tit-Bits.

"YOUR name," he stammered, "is—is written on my heart." "Yes?" she whispered. "But—but wouldn't it be much nicer if your name were engraved on my stationery?"—Inland Stationer.
 "SO BIGGINS has written an historical novel?" "Yes," answered Miss Cayenne. "Who is the hero of the book?" "The man who has undertaken to publish it."—Washington Star.
 TOMMY'S MOTHER—"Why aren't you a good boy, like Willie Bjones?" TOMMY—"Hu! It's easy enough for him to be good; he's sick most of the time."—Philadelphia Record.
 CURIOUS CHARLEY—"Do nuts grow on trees, father?" FATHER—"They do, my son." CURIOUS CHARLEY—"Then what tree does the doughnut grow on?" FATHER—"The pantry, my son."—Purple Cow.

WIFE—"I'm going into town to-day, my dear, to my bootmaker's, milliner's and dressmaker's. What does the paper say about the weather?" HUSBAND—"Rain, hail and thunder storms."—Bon Vivant.
 "WHAT'S the matter with the train?" asked the lecturer, vexed with the speed they were making. "If you don't like this train," the guard retorted, "you can get out and walk." "By Jove!" said the lecturer, "I'd do it; but a reception committee is to meet me at my destination, and I don't want to get in ahead of time."—Bystander.
 "HOW nicely you have ironed these things, Jane!" said the mistress, admiringly, to her maid. Then, glancing at the glossy linen, she continued in a tone of surprise: "Oh, but I see they are all your own!" "Yes," replied Jane, "and I'd do all yours just like that if I had time."—Central Christian Advocate.

The Housewife's Letter-Box

We shall be glad to have our readers answer any of the questions asked, also to hear from any one desiring information on household matters. We want this department to prove helpful to our readers, and from the letters we have received we feel sure that our aims have been realized. While there is no payment made for contributions to these columns, still our readers may feel that their help and assistance is doing a great deal for others. All inquiries and answers should be addressed to "The Housewife's Letter-Box," care of Farm and Fireside, Springfield, Ohio.

Questions Asked

- Will some one please tell me—
- How I can use burlap as a covering for a floor? Can I paint it, and what kind of paint should be used? F. D., Washington.
- How to take grape-stains out of my little girl's white dress? I washed the dress before I noticed the stains and they seem to have set in deeper. Mrs. M. W. T., Michigan.
- How to make good grafting-wax? Mrs. E. W., Connecticut.
- How to make rhubarb-wine? Mrs. J. V. S., Virginia.

Questions Answered

Some Egg-Plant Recipes, for E. S., New York

In preparing egg-plant for the table, I wash and slice it, and let the slices remain in cold salt water for fifteen or twenty minutes, to take out the "green" taste, and then roll in meal. I drop slices into hot fat and brown them on both sides. (Do not cook too rapidly, or they will not be done through, unless slices are very thin.) If pepper is liked, I add a dash of pepper, and more salt, if desired. When slices are rolled in meal they taste very much like fried fish, but if rolled in flour, you can hardly tell them from fried sweet potatoes. Miss M. K., Arkansas.

Instead of rolling the slices of egg-plant in meal, Mrs. E. S., of Washington, writes that she dips them in a batter of beaten egg, then in flour and fries them in butter. Editor.

Peel the egg-plant and cut in small pieces (take out the seeds if the egg-plant is very ripe); cook in salt water until tender. Then drain and mash with potato-masher. In a sauce-pan put first a layer of the egg-plant, some butter, pepper and salt; then a layer of cracker-crumbs, and so on, until you have used all the egg-plant, having the cracker-crumbs on top. Cover with rich milk and place in a hot oven to brown. Serve while hot. This has very much the flavor of scalloped oysters and is delicious. Mrs. B. I. G., Indiana.

Syrup From Granulated Sugar, for Miss E. R., Ohio

To make a syrup from either granulated or brown sugar that will not crystallize, add just sufficient water to the sugar to wet it; set over a fire and stir until all sugar is melted, but do not allow it to boil. As soon as melted remove and strain through two or three thicknesses of fine cloth and set aside to cool. A syrup results which for richness and sweetness is far superior to anything procurable at the stores. The addition of two teaspoonfuls of maple-extract to each quart (after taken from fire), stirred in well, gives a maple syrup that cannot be detected from the genuine. Mrs. M. H. W.

Saratoga Chips, for K. D. C., Pennsylvania

Wash and peel potatoes. Slice thinly into a bowl of cold water. Let stand two hours, changing the water twice. Drain, plunge the potatoes in a kettle of boiling water and let boil one minute. Drain them again and cover with cold water. Take from the water and dry between towels. Fry a few at a time in deep fat until light brown. Drain on brown paper and sprinkle with salt. If you want to prepare the potatoes in a hurry, they will taste almost as appetizing, if not allowed to stand in water two hours. Just pare them and slice, drain, dry between the cloths and fry. Mrs. S. J. R., Delaware.

Two Helps, for Mrs. G. DeM., California

Caramel-Cake: Two cupfuls of brown sugar, one scant cupful of butter, two eggs, two ounces of chocolate dissolved in half a cupful of warm water, one half cupful of sour milk, one teaspoonful of soda dissolved in the milk, three cupfuls of flour. **Icing:** Two cupfuls of brown sugar, butter the size of an egg, one half cupful of sweet milk, one teaspoonful of vanilla. Add chocolate if desired. Beat hard to keep from being brittle. Mrs. J. B., Ohio.

For grease-spots on wall-paper, rub stale bread on the grease-spots, rubbing downward, and I am sure it will remove them. Mrs. J. W. S., Kentucky.

Three Dandy Ponies To Be Given Away by Farm and Fireside

DON'T you want a beautiful pony and outfit, all for your very own, this very summer? Well, FARM AND FIRESIDE is going to give away Three Blue Ribbon Ponies and their outfits on July 30th, to three lucky boys and girls, and you can be one of them if you will hustle enough. Here is a picture of Fuzzy, the first prize pony, and his cart and harness. Fuzzy is the most beautiful pony you ever saw. He has a long, soft, silky mane and tail, and a pretty arching head. If you win Fuzzy on July 30th you will be the proudest boy or girl in the land. Just think, you can go driving every day. Get started right away if you want to win Fuzzy. Just one good effort and Fuzzy is yours.

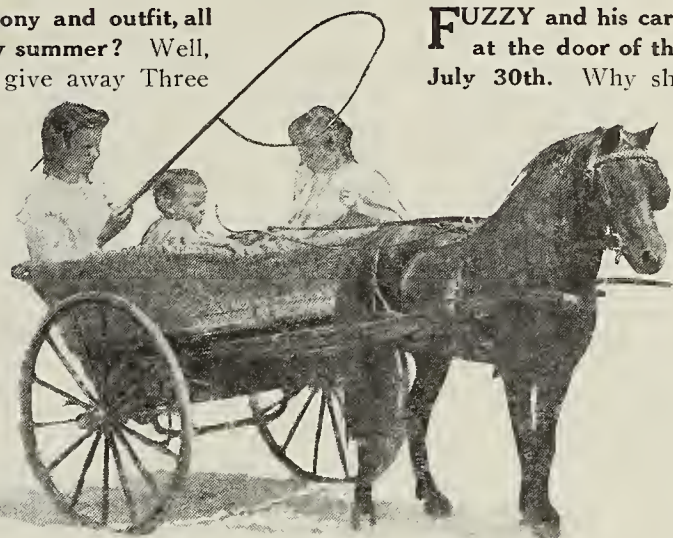

This is Fuzzy and His Cart and Harness He will be given away on July 30th

FUZZY and his cart and harness will be delivered at the door of the boy or girl who wins him on July 30th. Why should it not be you? All you have to do is to get enough friends and neighbors to subscribe to FARM AND FIRESIDE. That should be easy enough because FARM AND FIRESIDE is the best farm journal and because everyone will want to help you win. Below is a picture of Spot—third prize pony. Isn't he a dandy? You just bet he is. And so is Teddy, the second prize pony. Wouldn't you love to win one of these beautiful ponies? Dozens of boys and girls have won ponies from FARM AND FIRESIDE. What they have done you can do. Don't delay, but start at once.

Thousands of Dollars in Prizes

THIS is Farm and Fireside's greatest pony contest, and at the end of this contest, on July 30th, thousands of dollars will be distributed in ponies, prizes and rewards. In addition to the three ponies, three magnificent \$600 Harrington pianos are offered, and one hundred Grand Prizes, including bicycles, guns, talking machines, watches, sewing machines and everything you ever could wish for. You surely can win one of these beautiful prizes. In addition to all these prizes, we guarantee that every boy and girl who becomes an Enrolled Contestant will receive a valuable prize. Just get started, and you will be a prize winner any way. Write to the Pony Man without delay for full particulars how to win these valuable prizes.

WE GUARANTEE that every person who takes part in this great contest will be fully rewarded for all time spent. You can't lose. Even if you don't win a pony or piano or grand prize, you will be fully rewarded at the end of the contest by a valuable prize. What is more, you can keep a cash commission on every subscription you get. Could anything be more liberal than that? FARM AND FIRESIDE guarantees that this Pony Contest will be square and fair, that the ponies and other prizes will be awarded on July 30th as herein described, and that every Enrolled Contestant will be fully rewarded for all time spent in the contest. We wish every boy and girl in FARM AND FIRESIDE's large family to come into this contest.

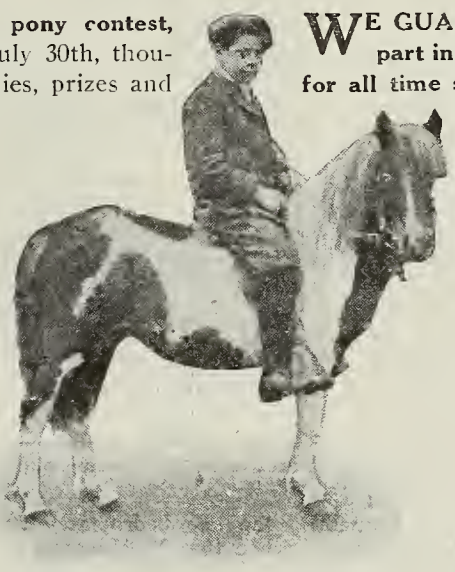

Spot, Third Prize Pony

A Prize For Every Contestant

IT'S IMPORTANT to get started at once. Send your name to the Pony Man to-day. Don't delay. You can't lose. Just get started and you are sure of a prize anyway, and you may win Fuzzy or one of the other beautiful ponies. Dozens of former pony winners say it's very easy to win a pony. Marguerite Lawson of Hopkinsville, Ky., winner of Wuzzy, says: "It was no trouble at all to get subscribers. Hardly anyone refused to subscribe to the paper." Howard S. Laidlaw of Walton, N. Y., winner of Prince, says: "Anyone can win if he hustles." Viva McNutt of Vandergrift, Pa., says: "I was bound to have Teddy and I got him. It is no trouble at all to get subscribers, but don't give up."

Keep in mind what other pony winners say: It's easy to get subscribers, and don't give up. Get started right away, ask your friends to subscribe to FARM AND FIRESIDE and to help you win Fuzzy, and Don't Give Up.



Would You Like A \$600 Harrington Piano?

WRITE to the Pony Man to-day. Just send a postal or letter and say: "Dear Pony Man: Please write and tell me all about Fuzzy, and how to win him." Sign your name and address in full. The Pony Man will send you at once, free, a lot of pictures of Fuzzy and the other ponies, and pictures of the Grand Prizes, and will send you a lot of valuable and interesting material, including a booklet written by former pony winners, with pictures of themselves and their ponies, and he will tell you just how to win Fuzzy. Be sure and write to-day. It won't cost you a penny.

You can be a prize winner, sure, if you will start right away and ask ten people, each to give you 25 cents for an eight-month subscription to FARM AND FIRESIDE. Keep 5 cents cash commission for yourself out of each 25 cents, and send the rest to the Pony Man. Don't wait for the Pony Man's letter—start to-day.

Send your name to the Pony Man to-day sure. Fuzzy and the other Ponies, and the Grand Prizes and all the other Prizes will be awarded on July 30th. We Guarantee that every Enrolled Contestant will receive a Prize. We further Guarantee that you will be Fully Rewarded for your time whether you win a pony or not. Get Started Right Away. Don't Give Up, and Success should be yours. Send your name to

The Pony Man, FARM AND FIRESIDE, Springfield, Ohio



OUR YOUNG FOLKS' DEPARTMENT

CONDUCTED BY COUSIN SALLY



Cousin Sally Writes About Van Cortlandt Manor



DEAR BOYS AND GIRLS:—

The other day I visited Van Cortlandt Manor, one of the oldest houses in New York City, and since so many of my boys and girls have asked me to write more about New York, I am going to tell you about the delightful time I had and all the old interesting things I saw.

Van Cortlandt Manor was built in 1748, one hundred and sixty-two years ago. While there is nothing presumptuous about the architecture, as you can see from the picture, still in every way it suggests solid comfort, which was one of the things that the people in those times considered most essential. It is made of rough stone with brick set about the windows, and above them on the outside are strange-looking stone faces, which are supposed to have come from Holland. The house is under the management of the Society of Colonial Dames of the State of New York, and in every room there is some ornament, furniture or other article used in the olden days.

To the right of the main hall was the parlor which in those days was used only for very formal occasions. At one side of the room is an old spinnet, and as I stood looking at it I could picture in my mind how bright and gay the room must have been, with the lights from the many candles in their old-fashioned holders, flickering on the dignified colonial dames in their quaint brocade frocks, and on the men dressed in satin knickerbockers and elaborately trimmed waistcoats, as they danced the stately minuet to its music. The furniture was very old, made of mahogany upholstered in heavy tapestry, and the attendant told me that one of the chairs belonged to Henry Clay. From this room I crossed the main hall and entered the museum on the left. When George Washington visited Van Cortlandt Manor in 1783, this was his bedroom. I could hardly realize that here I was, across the very threshold, which many, many years ago our first president had been. The room is used for a museum and in it are all sorts of odd relics. On one side were two immense vultures made of wood. They were taken from a Spanish privateer in the Revolutionary War and presented to August Van Cortlandt by Admiral Robert Digby, of the British navy. In the center of the room were two long glass cases. One of them contained old law documents and letters written by hand. Many of them are so faded that the writing is hardly readable. A little farther up in the case was a splendid collection of rare china—cups, saucers and tea-pots. In front of a table lay a card on which it said, "Made by Paul Revere," and right next to this spoon was another which belonged to General Israel Putnam. You remember him from your history-book, don't you, for he made a name for himself in the French and Indian War and was also famous for his bravery in the Battle of Bunker Hill.

The other case contained old newspapers printed more than one hundred years ago. Among them was one which contained an account of the death of George Washington. There were many more things of interest in this room, but I shall have to skip over them, or there won't be space left to tell you about the other rooms.

The dining-room is also on the ground floor in the rear. Such a quaint old-fashioned room as it was! The furniture was arranged just as all dining-rooms were in the olden days. Nothing was fancy or in any way elaborate, but everything was substantial and put there for comfort and use. There was the old-fashioned oval table set with

pewter dishes, and against the wall was a massive side-board of solid mahogany, and it, too, held several pieces of silver and pewter ware. Built in the wall at the side of the mantel stood a small closet used as a receptacle for foods and delicacies. On the opposite side of the room set across corners was another closet which was used to hold china ware. It contains some very rare pieces of china. On the right side of the room stood a massive cabinet on which was a pewter platter from the Franklin House in Franklin Square, which, in 1789, was used by George Washington as the presidential mansion. Near a window on the floor stood a tall quaint old clock, which no longer ticks, its life having long since passed away with the people who made the old house glad with their laughter and gaiety. Many distinguished people have dined in this room and made merry. General Washington and the French general, Rochambeau, were guests, and later came King William IV. of England and Admiral Digby. Many brilliant speeches and toasts have been made here and as I thought of all these things a deep reverence and esteem for the good, brave people of those days passed over me. I felt like an intruder and that any minute the good dame of the house would come down the stairs with stately tread to see what hour of day it was and if it were time for the evening meal, so I turned on my heels and quietly tiptoed out of the room.

From the dear old dining-room I went up-stairs to see

feet. The room had the usual deep window-seats and near one window was an old-fashioned washstand with the bowl and pitcher. The bedroom across the hall was somewhat similar, so I shall not stop to tell you about it.

In the hall between the two rooms were two wardrobes which were most interesting. In one there were slippers worn by the colonial dames (and such little feet as they had)—some had high heels, others had flat soles; then there were queer-looking "pattens" which were used for rubbers; calashes, which looked for all the world like the fetching automobile hoods worn to-day by our women, except that the calashes were a great deal larger. There were leghorn poke-bonnets, having tall stove-pipe crowns; queer spectacles, large earrings, odd-looking bracelets and huge back combs, and on one of the shelves was a small pincushion made of silk from Dolly Madison's favorite chair.

Now for the other case, which I liked better. It held the most fascinating variety of gowns, and clothes worn by the men and women of those days. The frocks worn by the colonial dames were made with tight-fitting bodices and full gathered skirts, and I can just imagine how quaint and bewitching they must have looked in them. But the men's clothes! They were even more fussy than the women's. The waistcoats were most elaborately trimmed with gold-embroidered bands and gold buttons, and there was quite a fancy coat hanging there which was worn by John Quincy Adams when he signed the Treaty of Ghent. Think of it!

From here I wandered through the hall, past the bedroom to the old spinning-room in the back where there was an interesting assortment of spinning-wheels. Going down two flights of stairs in the rear brought me to the quaint old kitchen. It was built below the ground floor as our cellars are and was directly under the dining-room. There was the huge open fireplace with its large iron pots, kettles, caldrons, long-handled shovels, waffle-irons, and on each side was an old Dutch oven. And there was the skillet and the wooden scale that the servant used for measuring out the flour. Above the mantelpiece was a flint-lock gun and powder-horn. On the oblong table were all sorts of cooking-utensils—wooden chopping-bowls, wooden spoons and sticks (I had not the slightest idea what they could have been used for), rolling-pins, irons, pots and pans of all kinds, bread-boards, a spice-grinder and many other articles that were unknown to me. Against the wall was a large dresser filled with old pewter dishes. There stood two dasher churns, a large brass milk-can, just like those used in Holland, a tin mold for making candles, a lamp with a reflector, and to the right was a generous-sized settle. It did look so comfortable.

So this was the old Van Cortlandt Manor! I was glad I had seen it. Here it was, just as the houses of the aristocrats were furnished in those olden times, but the people—where are they? Gone! Gone forever! But the good work and good deeds they did live after them, and the memory of them can never die! We love to think of those days and how our fathers fought for their beloved country, and until time immemorial they shall be remembered and revered by every staunch and patriotic American. As I left the old historic place, I felt glad and proud of my country, and glad, glad that I was an American!

So I have told you about my visit to the old manor. If it interested you, perhaps I will tell you about other old places in New York City. Write to me soon, and remember that every letter is always welcome that is sent to

Yours faithfully,

COUSIN SALLY.

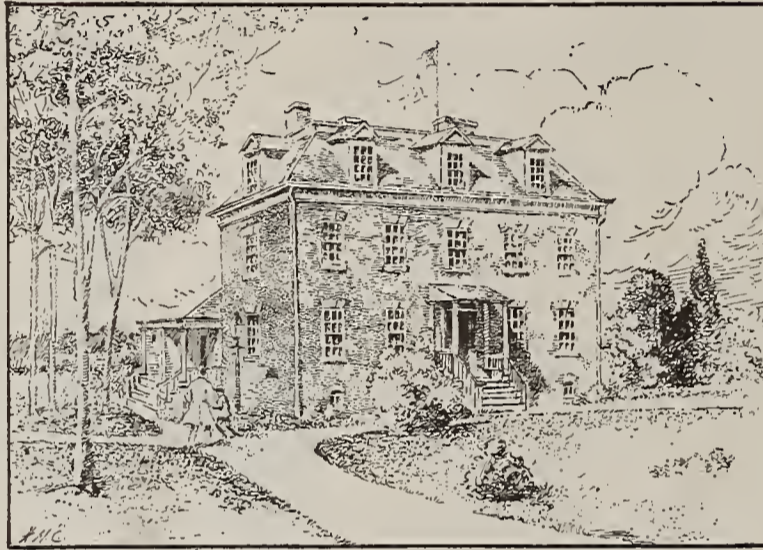

Van Cortlandt Manor—one of New York's oldest historical houses

the two bedrooms. The room to the left contained the bed that Washington slept in when he made his first and only visit to the old manor. How they climbed up in those high beds was a mystery to me, but when I looked closer, I saw that there were steps at one side to overcome this difficulty. Such a huge bed as it was with a mahogany top over it and the sides and foot inclosed in lace curtains. Close by the old-fashioned fireplace was a brass and a copper warming-pan, used to heat the beds. On the massive mahogany desk to the left side were several things which interested me—a jelly-glass used by George Washington, a small cannon-ball marked "Battle of Long Island, 1776," and pasted on cardboard in a gold frame was a piece of corn-colored brocade silk from Martha Washington's wedding dress, also a piece from Washington's bed curtain. To one side of the room was a gout-rest used in those times by old men with gouty

Heart's-Ease

By Ethel Holland



IN A corner of an enchanting old garden, near a bed of saucy pansies, there bloomed a little heart's-ease. So modest and tiny was she that the larger and more gorgeous flowers quite ignored her. Often-times the garden rang with the tinkle of the bluebells—was astir with the soft flutter of butterfly wings and the low hum of bees. But in this merry-making the heart's-ease had no share. The birds paid court to the blushing roses; the butterflies fluttered around the gay little pansies; the bluebells and the bees kissed—alas! the tiny heart's-ease was quite alone.

A fuzzy brown caterpillar one day appeared in the garden. As he made his way slowly down the path, the flowers laughed in derision. "What an ugly brown thing he is," said one saucy pansy. The roses merely curled their pink lips in scorn. Quite crushed, the caterpillar, who had heard, crawled dejectedly on his way. In this beautiful garden there was no place for one so ugly.

Suddenly he saw a little flower nodding and smiling timidly at him. It was the little heart's-ease who looked at him so kindly. Bending her head, she nodded cheerily, and the caterpillar paused. The world seemed bright, the garden a beautiful place, his path no longer a weary one. Each day thereafter he was to be found on the edge of the pansy-bed, where bloomed the heart's-

ease. And quite a merry little flower she was now, with many smiles and nods for fuzzy Mr. Caterpillar. She was no longer unnoticed, for her funny brown visitor had brought much ridicule down on her tiny head. But not a bit did the heart's-ease care—not a bit cared the caterpillar. Day by day they basked in the sunshine and day by day the face of the heart's-ease became more wonderfully sweet.

One morning the brown caterpillar did not appear in the garden. Two, three and four days passed and still he did not come. The flowers were amazed. The roses and pansies whispered together, wondering where the ugly thing could be. They were glad, they said, that the garden was rid of his homely presence. No doubt he had found another friendly flower, one far lovelier than the modest heart's-ease.

Poor little posy! Her head always

drooped now. There never was a smile in her violet eyes and her frail little body seemed lifeless and withered. So pitiful did she look that the other flowers refrained from teasing her, and once more she was unnoticed. So the days passed and the garden was as it had been before the appearance of the fuzzy brown caterpillar.



"The visitor alighted on the very edge of the pansy-bed"

The bluebells tinkled merrily one day, when they flitted over their heads the most superb butterfly that had ever graced the delightful old garden. His gorgeous black and yellow wings set all the flowers aflutter. The roses were delighted and lifted their pink faces appealingly to him. But the beautiful creature did not tarry with the roses. He left them red with mortification and flew on to the daffodils. They smiled and nodded graciously to him

—gladly would they have welcomed him to their part of the garden. Still he lingered not. The hollyhocks flirted outrageously with him, but he would have none of them.

Then a wonderful thing happened. The most beautiful visitor the gay little garden had ever known alighted on the very edge of the pansy-bed!

And the little heart's-ease nodded and smiled and swayed with the breeze. Her small face was aglow with happiness. The eyes of the pansies were wide with astonishment and the roses were pale with envy.

There was much gossip in the garden that day. The flowers wondered and guessed about the handsome yellow and black fellow. No one seemed to recognize in him the ugly, fuzzy, brown caterpillar who one day entered a garden of scornful flowers and found on the edge of the pansy-bed his heart's-ease.

Monthly Prize Contest

TO the six boys or girls sending in the best copy of the drawing of the picture which illustrates "Heart's-Ease" we will give prizes as follows: Books, water-color paints and post-card albums. Write name, age and address on your drawing and make it larger than the picture. The contest closes July 2d and is open to all boys and girls seventeen and under. Address Cousin Sally, care FARM AND FIRESIDE, 11 East 24th Street, New York City.

Fads and Fashions

By Miss Gould



Madison Square Patterns

THESE are the patterns that are right in fit, right in style and right in price. For every design pictured on this page we will furnish a pattern for ten cents. They are the most economical patterns to use because of their adaptability. Oftentimes one pattern can be converted into two entirely different looking waists or skirts. For instance, from one ten-cent paper pattern may be made a plain tailored shirt or a dressy lingerie waist.

We have a liberal offer to make you in regard to these patterns. Here it is: We will give one Madison Square pattern if you send us only one new eight-month subscription to FARM AND FIRESIDE at the special price of twenty-five cents. The subscription must be for some one not now a subscriber to FARM AND FIRESIDE. This offer holds good up to July 10th. Send orders to the Pattern Department, FARM AND FIRESIDE, 11 East 24th Street, New York City.

Follow these directions when ordering patterns: For ladies' waists, give bust measure in inches; for skirts, give waist measure in inches; for misses' and children, give age. Don't fail to mention the number of the pattern you desire. Satisfaction guaranteed.

A distinctive feature of the Madison Square patterns is the originality of their designs—up to the moment in style, but never extreme.

If you have not seen the new pattern catalogue of Madison Square patterns, you will find it to your interest to send for it. The price of this catalogue is ten cents. Order catalogue from the Pattern Department.

A NEW fad, and one that seems quite strange to us who are so familiar with the barn-yard, is the rooster craze called "Chantecler"—for that is the name by which our erstwhile plain rooster is now known. But, strange as this may seem, it has been a fact ever since Edmond Rostand, a noted playwright, electrified Paris by choosing for the setting of his new play a plain barn-yard, and, for his characters, the rooster and his feathered followers.

Fashion has taken up this fad and fans now show a gay cock as their decoration; brooches, pins and many other trinkets in jewelry are seen with the rooster design.

And does this new fad include jewelry alone? No, indeed. Laces and embroideries with rooster decorations, hats with rooster trimmings, and even dresses themselves show the effect of this new rooster craze—Chantecler.

THIS very good-looking morning dress will be a useful addition to any woman's summer wardrobe. And the pattern is the most economical one she can buy. Its price is but ten cents, including the smart-looking skirt and waist, shown in the illustration on this page. This waist may be modified to look dainty and attractive by a side frill and a smart standing collar. It would be a bright little trick to make up the waist in both these styles for this dress, having the plain one very tailored in effect, by simply using plain machine stitching, and the other one a little more dressy by embroidering the collar and frill in some bright tone or edging it with the same material in a contrasting shade.

Madras, gingham and cotton rep are good materials, and of gray, blue or green, with black or red embroidery, and cut from pattern No. 1548, one can have a most attractive and modish gown.



No. 1340—Empire Kimono

Pattern cut for 32, 36 and 40 inch bust measures. Quantity of material required for medium size, or 36 inch bust, ten and one half yards of twenty-two-inch material, or six yards of thirty-six-inch material, with one and one half yards of contrasting material for trimming-bands

If you want to dress well and are not quite sure how to go about it, then send for our new pattern catalogue. It contains a variety of the newest summer fashions and will give you just the help and suggestions you have been looking for. Its price is but ten cents—a very small sum for such a big, beautifully illustrated fashion book. Its tinted cover is so charming and attractive that you will probably want to frame it. Send order to Pattern Department, Farm and Fireside, 11 East 24th Street, New York City.



No. 1548—Morning Dress—Waist in Two Styles

Pattern cut for 32, 34, 36, 38, 40 and 42 inch bust measures. Quantity of material required for medium size, or 36 inch bust, nine and five eighths yards of twenty-four-inch material, or five and seven eighths yards of thirty-six-inch material

Why not make your own clothes? Let the Madison Square Patterns help you and make your first attempt a success. Send for our new summer catalogue and select from its many attractive designs one that is adapted to your individual needs. Then order your Madison Square pattern and you will be surprised to find how easy it is to use. It will be impossible for you to ruin your goods. Order Madison Square Patterns from the Pattern Department, Farm and Fireside, 11 East 24th Street, New York City.



No. 1255—Nightgown With Square Neck

Cut for 32, 36 and 40 inch bust measures. Material required for 36 inch bust, four and one half yards of thirty-six-inch material, with one fourth of a yard of all-over lace or inserted tucking for the yoke, and two yards of lace edging for neck and sleeves



No. 1267—Double-Breasted Plaited Shirt-Waist

Cut for 34, 36, 38 and 40 inch bust measures. Quantity of material required for 36 inch bust, four yards of twenty-seven-inch material, or two and one fourth yards of thirty-six-inch material



No. 1299—Child's Russian Dress With Yoke

Cut for six months, one and two year sizes. Material required for one year, two and three fourths yards of twenty-seven-inch material, with three eighths of a yard of all-over embroidery



No. 1470—Child's Yoke Dress

Pattern cut in 1, 2, 4 and 6 year sizes. Quantity of material required for medium size, or 2 years, two and five eighths yards of twenty-four-inch material. Hand embroidery would make the collar very pretty



No. 1281—Short-Waisted Guimpe

Pattern cut for 32, 34, 36 and 38 inch bust measures. Quantity of material required for medium size, or 36 inch bust, three yards of twenty-two-inch material, or two yards of thirty-six-inch material

HARD ON CHILDREN

When Teacher Has Coffee Habit

"Best is best, and best will ever live." When a person feels this way about Postum they are glad to give testimony for the benefit of others.

A school teacher down in Miss. says: "I had been a coffee drinker since my childhood, and the last few years it had injured me seriously.

"One cup of coffee taken at breakfast would cause me to become so nervous that I could scarcely go through with the day's duties, and this nervousness was often accompanied by deep depression of spirits and heart palpitation.

"I am a teacher by profession, and when under the influence of coffee had to struggle against crossness when in the school room.

"When talking this over with my physician, he suggested that I try Postum, so I purchased a package and made it carefully according to directions; found it excellent of flavour, and nourishing.

"In a short time I noticed very gratifying effects. My nervousness disappeared, I was not irritated by my pupils, life seemed full of sunshine, and my heart troubled me no longer.

"I attribute my change in health and spirits to Postum alone."

Read the little book, "The Road to Wellville," in pkgs. "There's a Reason."

Ever read the above letter? A new one appears from time to time. They are genuine, true, and full of human interest.

BUY ROMPERS BY MAIL

DIRECT FROM FACTORY

All Charges Prepaid



LET us supply your children's Rompers direct from the factory and save you the middle-man's "great big profit"; our Rompers are the best that can be produced—durable, serviceable, fast color and will stand many trips to the wash tub. Choice of pink or blue, checked chambray, with neck, collar and belt bound in white.

5 for \$1.00

ROMPERS made of good grade Madras, with yoke, rolling collar, belt and pocket piped in white; choice of assorted checks 3 for \$1.00 and stripes.

ROMPERS made of an excellent grade of linen suiting that wears like "buckskin"; dressy patterns with rolling collar, yoke and cuffs piped in white; belt piped and faced. Tan and Cadet 2 for \$1.00 Blue.

These ROMPERS will not shrink, they are exactly as represented—worth double our price. SIZES 2 TO 6 YEARS. ALL CHARGES PREPAID. Satisfaction guaranteed or money refunded. Specify size and color. REMEMBER our offer of 4 aprons for \$1.00 from factory to you; all charges prepaid.

CONSUMER'S APRON COMPANY
76 Clymer Street, Brooklyn, N. Y.

Do farmers eat the proper sort of food?

The farmer of today buys a much larger proportion of the food that goes on the table than he did ten years ago. It's a good thing that this is so because he has a great variety to select from.

He should, however, use great care in selecting for the best results in health and strength.

The widespread tendency in the city to increase the amount of Quaker Oats eaten is due very largely to the recent demonstrations by scientific men that the Quaker Oats fed man is the man with greatest physical endurance and greatest mental vigor.

Farmers should give this subject careful thought and should increase the quantity of Quaker Oats eaten by themselves, their children and the farm hands.

STEM-WIND&SET **EARN** WATCH RING and CHAIN BY SELLING 18 CARDS OF 10c ART JEWELRY WE GIVE a plated gold watch like picture, GUARANTEED 5 years, (together with chain), also imitation DIAMOND RING having two sets for selling 18 cards of jewelry at 10c each. LADIES' SIZE WATCH for selling 24. Order jewelry—sell it—send pay—get premiums. S. Spencer, Horton, N. Y.

Ladies & Gents Watches **GIVEN** We give all grades of Watches for selling our Fine Art Post Cards at 10c per pkg. Order 20 pkgs. today. When sold, send us the \$2.00 and we will send you an elegant 5 YEAR GUARANTEED WATCH, also a FINE SIGNET RING and a CHAIN, postpaid, as per our premium list. IT COSTS YOU NOTHING. Write us today. BELMONT MFG. CO., Dept. 90, CHICAGO

LEARN TO WRITE ADVERTISEMENTS IF YOU ARE EARNING LESS THAN \$25 A WEEK we can positively show you by mail how to increase your salary. Send for beautiful prospectus, mailed FREE. PAGE-DAVIS SCHOOL, Dept. 25, Chicago, Ill.

PARKER'S HAIR BALSAM Cleanses and beautifies the hair. Promotes a luxuriant growth. Never Fails to Restore Gray Hair to its Youthful Color. Cures scalp diseases & hair falling. 50c. and \$1.00 at Druggists.

Sunday Reading

"We Do Need You So!"

"WE do need you so!"

For many years he had lived in that quiet country neighborhood. Then came a chance which took him away out of the country. On a visit to his old home the neighbors crowded around him, pressing his hand hard and looking into his face with tears. These expressions could not but touch his heart; but the thing which stirred him most of all was when a friend, holding him close by the hand, said:

"I wish you would come back here! We do need you so much!"

We need you so.

Who would not have that said of him? Just to feel that some one, somewhere, knows us so well and appreciates the sterling qualities of our natures enough to want us always near—what could be sweeter? What could make the sunshine brighter in the sky of life?

Who are the men and women that are most needed in this world? Surely there must be some reason why those who know us should feel glad when we are near. We cannot claim a tribute like that unless we are worthy of it. The heart of the world does not reach out after those who have nothing in them which responds to that yearning.

It is worth while to look into our own hearts on the days when we feel that we are shut out from doing anything to make the world brighter and better, so that no one cares much for us, and see whether the fault be not our own. Stop and think why it was that this man's neighbors longed for him to come back to them once more.

Be Ever Ready to Help

He helped folks he met on the road of life. Men and women who had trouble liked to come to him and talk about it. He never was too busy to sit down and listen. Many a time he came out of the field when the days were very busy just to hear the stories of those who had sorrow and needed a word of sympathy or a bit of advice as to what they ought to do. It took time to do this. The crops were waiting for the touch of his hand, but here was a heart that needed him more than did the wheat out in the field or the vegetables in the garden. So he listened; he gave the best advice he could, and he went back to his work leaving some man stronger and braver to go on with his burdens.

And, then, this man had a heart as simple as a child's. Young folks loved him. Little boys and girls sent him flowers when he was sick. Even the cows and the hens and all the farm creatures came to know his voice and loved to be near him whenever he was on the old place. Tired men and women listened for his whistle when he was at work away up in the field and went on with their own work more cheerily.

But the thing which most of all drew people to this man was the fact that he did not live all for himself.

Stop now and think what selfishness does. Away back in the field stands a lonely house. A hedge higher than the top of the highest peak shuts out the gaze of those who pass that way. The old man who lives in there has money—plenty of it. And yet he is a beggar. Nobody ever comes to see him. They did once, but they met a dog at the door and went away to stay forever. There he lives, all by himself, the worm of selfishness eating him up alive.

We Get What We Give

But what a magnet unselfishness is! The polar star is a feather by the side of the love which gives itself fully and freely for others. It reaches out and brings to it all the tired, all the footsore, all the storm-tossed ones of earth and rests them and puts balm on their wounds and furnishes them a haven from the tempest.

And how sweet it is to think that there are so many who are in these ways helping to lift up the world! Sometimes we get tired and think everything is going down to destruction. Men and women who may be called Knights of the Pure Heart then seem so few! Where are they, anyway?

Dear heart, do not be discouraged! All is well! Just pray for eyes that can see; that is all.

If you want to be needed, give something worth while. Do not be afraid you will empty your hand. It never was more full than when you gave most. Let it go wide open, then, and trust God to fill it for to-morrow's harvest. He will do it and your life will be richer, fuller and grander.

EDGAR L. VINCENT.

The Freezer Makes the Ice Cream good or bad—it's ALL in the Freezer!



The "White Mountain" is distinctly the home freezer, because it is failure-proof and lasts a lifetime. You can't spoil good mixture if you use the

Triple Motion WHITE MOUNTAIN Ice Cream Freezer

Strong, simple, durable, the "White Mountain" is mechanically perfect. It freezes easily and quickly. The triple motion produces light, fluffy frozen dainties, unusual in quality and quantity because paddles are separate and each works independently of the other and works in opposite directions.

Look for the diamond trade mark on the wrapper.

No gears on the "White Mountain" lid to connect and work up, or get rusted. No cog wheels exposed to the ice. This freezer has many other exclusive points of superiority!

Write to-day for our booklet, "Frozen Dainties." It tells all about making inexpensive, delicious frozen desserts.

THE WHITE MOUNTAIN FREEZER CO., Dept. Y, Nashua, N. H.

The Right Way to Buy Soda Crackers

—and the simplest way. Ask for them by name—and the goodness will take care of itself. Buy

Uneeda Biscuit

Then, no more broken, soggy, stale or exposed soda crackers. Uneeda Biscuit come in individual packages that hold just enough for each soda cracker occasion. Fresh when you buy them. Whole when you open the package. Crisp as you eat them.

A number of five cent packages of Uneeda Biscuit is a wiser purchase than a quantity of ordinary soda crackers in wooden box or paper bag. Never sold in bulk.

NATIONAL BISCUIT COMPANY

FARM AND FIRESIDE

THE NATIONAL FARM PAPER



ESTABLISHED
1877

JUNE 25
1910

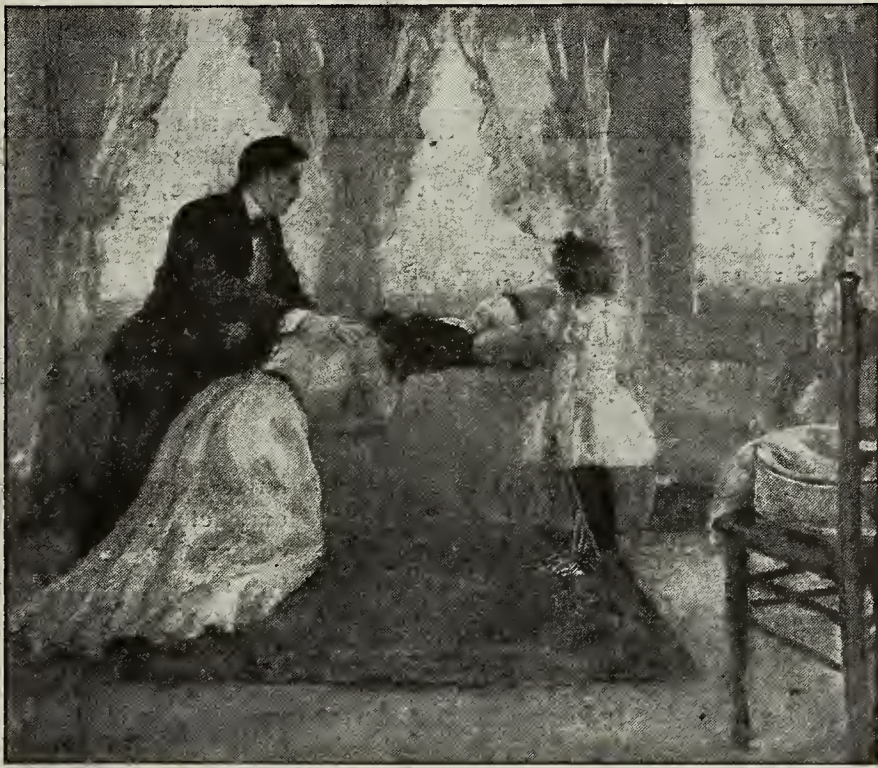

Copyright, 1902, Life Publishing Company

Drawing by H. G. Williamson

Would You Rather Have This Kind of a Fourth—



Drawing by C. M. Relyea

—or This?

STOP THE SLAUGHTER

We believe in the old-fashioned Fourth. It is the great day for the boy. It is noisy, but we cannot stop the noise without stopping the boy. Let the boy have his fun. But—two hundred and fifteen of them cannot have their fun this Fourth because they were killed last Fourth. Five thousand more were blinded or maimed. This is not fun, nor is it patriotism—it is slaughter, the slaughter of the innocents! ❀ Are you going to turn your children loose this Fourth with fire-crackers and other explosives, when such awful possibilities are staring you in the face? If they have their hearts set on “shooting off things,” in heaven’s name! don’t let them do it unguided and unrestricted. Take the reins in your own hands and show them how to do it safely. ❀ ❀ ❀ ❀

A Visit With the Editor

ONE of the pleasures of life, in connection with being the ostensible head of the FARM AND FIRESIDE family, is the mail-bag. Nobody else gets such letters as the editor, I think. Some of them are pathetic with the pathos of the eternal struggle with life—pathetic beyond anything in books. Most of them are very cheering. Among the latter are those from people who are stopping the paper. You'd naturally think these would be a sort of damper on the feelings—but they aren't. They cheer us all up immensely.

Why?

Because not one of them yet received says, "I stop FARM AND FIRESIDE because I can get a better farm paper." Not one of them says, "I stop FARM AND FIRESIDE because it isn't worth the money." One disagrees with us on the matter of parcels post. One, a Democrat, thinks our Washington letters have favored the Republicans too much; one, a Republican, thinks we have favored the Democrats too much. These two are men rather set in their views and driven away because of the progressive tendencies of the paper. We wave them good-by and say, "See you later! If you're right, we'll be with you one of these days. If we're right, hope you'll join us when you find it out. Our position on public affairs, after all, isn't the main thing with us. The main thing is, 'How can we make farming pay?' Better stay with us on that, anyhow—but if you won't here's good fortune to both of us!"

And most of these very people—there are mighty few of them, by the way—wish us good luck and say we're making a splendid paper—good friends, you see, temporarily feeling a little pudgicky at us.

Many of the people who stop FARM AND FIRESIDE are folks who have moved to town and don't need it any longer. A lot more are old folks whose hands tremble as they write that they can't use the paper any more, that it has been a friend for years and years, and that they have already taken it longer than they could use it. And the majority of them tell us what a good paper we are making and that they don't see how we can do it for the money and that they like it better than any other paper of any kind.

If this be the tone of those who are stopping the paper, you may imagine the praise of those who are renewing. Sometimes we print a few of these. All of them, would more than fill the paper. They encourage us greatly. We know that FARM AND FIRESIDE isn't anywhere near as good as it will be one of these days, but we like the compliments, just the same, and we hope some of them are deserved.

Some of the letters touch bed-rock. Sometimes I get a criticism of an editorial, that I take out of the bag and mull over for a month. I have one before me now, that I have been mulling over for two months or more—it is dated Rutland, Ohio, March 21, 1910.

"I desire to take exception," says this critic, "to the belief in the masses of our people expressed in the closing paragraph of your editorial in the twenty-fifth of February. The people of this country have it in their power to control the government and take care of their own interests. As Alfred Henry Lewis says, 'In the eternal fitness of things, men deserve man government and dogs deserve dog government,' and that is just what they get." And then follows an able discussion of the fitness of the American people for self-government.

As I said just now, this letter touches the very foundations of things. We are talking together as farmers. We are immensely interested in knowing for one thing who gets the money the consumers pay for our products. In Madison, Wisconsin, I paid ten cents the other day for three Ben Davis apples, and a quarter for six Northern Spies. Flour costs three dollars and twenty cents and upward a hundred. Milk sells at from seven to ten cents a quart for the common, and twenty-five and upward for the certified article—which is another way of saying really clean milk. Chuck roast is sold around twelve and a half cents a pound, while porterhouse and veal steaks are paid for by the consumer at twenty to twenty-two cents a pound. These are not New York or Chicago prices, but those prevailing as I write in a small city in the heart of the corn belt.

Who gets the money? The farmers get a share of it, of course, but do they get their full share? This is a thing which we ought not to be obliged to ask ourselves. If we were making the best use of our brains as human beings, we should know to a dot just what ought to be added to the price on the farm for getting the stuff we sell on the table in Boston or New York or Chicago or New Orleans or Denver or San Francisco or Seattle or London. It's no mystery. The shipments might be followed from man to man, and the charges figured out—so much for hauling, so much for freight, so much for storage, so much for the retailer, and the like, and all these charges distributed into labor, rent, etc., until every one of us could set down a column of figures and tell to a fraction of a cent just who got the consumer's dollar that he pays for three pounds of your butter or six boxes of your strawberries or five pounds of your pork.

Do we know these things?

We do not.

We don't use our heads. The thing is too big for me to work out alone or for you or for any one of us. It's a thing for collective labor. We should cooperate in learning the leaks and in stopping them, by better marketing. But we don't, except to a degree. Doesn't this prove what my critic in Rutland says?

Yes and no—it proves it in a way. It proves, perhaps, that we are getting dog government—or at least dog treatment; but it doesn't prove that we are dogs, by a long shot.

I went last week to hear Professor Boeggild, of Copenhagen, Denmark, tell about the cooperative dairies of that little kingdom. The professor's talk shows that the farmers of Denmark are living under a man's organization, not a dog's scheme of things. The middleman is out of it, there—non-existent, *non est inventus*, off the map. The farmer gets absolutely all he produces—or at least that's what Frederick C. Howe says.

Who has done this? Has the king bestowed this excellent government on the Danes? Not on your life! Kings will do anything in the world for the people—like the privileged classes everywhere—except get off their backs. The Danes still carry the royal family on their backs, but they don't let them govern the country.

Who governs Denmark? Just such people—

I was about to make an awful blunder. I was about to say, "Just such people as you and I." And then I thought of the insult it is to an American farmer to call him a "peasant." But I say to you, if we could only get together, as the Danish peasants have done, and give ourselves the business organization they give themselves, we might very well stop quibbling with words and call ourselves peasants or even serfs—if at the same time we could only run our government and get our share of the consumer's dollars! I, for one, would stand for it.

But, as I was about to say, Denmark is governed by her peasants. By sheer force of numbers, they elect fifty-five out of one hundred and fourteen members of their governing body, the Rigsdag, and there are twenty-four socialist members from the cities—so that the "proletariat" control the government completely. They have a thousand cooperative dairies in that little state the size of Massachusetts. Practically all the peasants belong to these cooperative dairies. They have their own agents in the big markets

of England. They know who gets the consumer's dollar to a nit's eye. They are not bled by a trust, anywhere—they ARE a trust! A trust was formed once in London to beat down the price of their bacon in the British market and they retorted by forming a distributing agency of their own and doing business. And the trust closed its doors for want of anything to work upon.

These peasants are men owning from an acre and a half to ten acres of land, on which they keep from three to four cows and from ten to fifteen hogs.

They have twenty-nine agricultural colleges. They give Denmark the best government for everybody of any nation in Europe, unless it be that other peasant-ruled nation, Switzerland. Education is universal. The cities are splendidly governed. Copenhagen has the best and cheapest milk-supply in the world, perhaps, for a city of its size. And with cheap milk for the consumer goes good prices for the dairyman—the result of a man's organization, rather than a dog's organization.

The same sort of thing prevails in New Zealand, where a labor government has ruled the nation for nearly twenty years—a government of the working people of the island. Australia has gone into the hands of the laboring classes—farmers and artisans—because, I suppose, of the success of the government of the people by the people in the neighboring island of New Zealand.

And here's the answer to my friend at Rutland: The closer you get government to the soil, the better it is for the nation. The people have the intelligence and the brains to govern society. Democracy is a success wherever it is fairly tried. The commonest of the common people, yes, the slums of the cities, if you please, and the hardest-working, hardest-up farmers, will come nearer giving us real man's government than the most exclusive circle of high brows and financial magnates. Why? Because the common people are the only ones whose interests all run with the general welfare. Everybody but the commonest common people have axes to grind.

And at that, don't any of you people think that I think the American farmer any smarter than he should be. If he was half-way up to his job, he would be getting together and doing things, as the Danish peasants have done. The American farmer, on the whole, is a rather unintelligent citizen. But he is, I think, on the whole, more intelligent than the lawyers, bankers and corporation employees who are running things now. He could do a better job of ruling the nation than they do, never doubt that—for just such people do the job better where they take hold. The difference between myself and my friend in Rutland is this: I think they are going to take hold—he doesn't. Wait and see!

Oh, the Naughty Farmer!

'Tis not the trusts that we should blame
When that far-famed price-lifting game
Boasts porterhouse and prunes and
eggs
And caviar, fowls with yellow legs,
False hair, false teeth, asparagus—
Ah, no, the trusts are kind to us.
Who boosts the price of hog and
shoat?
Look at the farmer. He's the goat.

Look at the farmer, stooped and
lean;
See how he rises to be mean
At 4 A. M. and feeds the chicks
And gropes about and gathers sticks
To make a fire to cook his cakes;
Then plows and drags and hoes and
rakes
And raises cabbage, beet and squash.
He raises everything, b'gosh!

He raises things! That proves that he
Raises the things which used to be
Within our reach—steel rails and
coal—
Till if we had a ten-foot pole
We could not reach them! Silks and
furs
And tabby-cats and yellow curs—
He raises everything we use,
From clothespins to low-quarter shoes.

Ah, trusts, dear trusts, sweet trusts, to you
We make a quick salaam, we do!
Go past in your automobile,
Throw us your dust—please do—we
feel
We've been unjust! The farmer man
Soaks us. We ought to tie a can
To him! His work is hard and low,
And so we're glad you get the dough.
—Exchange.

Robert Guied



Vol. XXXIII. No. 18

Springfield, Ohio, June 25, 1910

PUBLISHED
SEMI-MONTHLY

New Life to Old Farms

Why is it that farms run down and are abandoned? How can abandoned farms be restored? We recently asked those questions editorially. Here are some of the answers—stories, most of them, of "common farmers," without large capital or other advantages, who have won success on farms given up as irreclaimable. We have seldom handled such a hope-inspiring set of letters. More of them will be published in an early issue. EDITOR.

Winning Without Capital

USUALLY abandoned farms are purchased by lawyers and bankers who have sufficient money to restore fertility and place the worn and run-down land on a paying basis. Then comes along some agricultural writer who tells a great story of what some rich man did. This does not make very interesting reading for a man with no funds, for he knows full well he cannot follow in the footsteps of the wealthy banker.

But it is for the benefit of very poor men that I write. Two miles back from the village of Rome-on-the-Ohio is a farming community situated on the west prong of Stout's Run. Thirty-five years ago a raw German, by the name of Adam Adloff, made his appearance there and purchased a run-down farm which cost him every dollar he had. It goes without saying that the people round about told Mr. Adloff he had paid twice what his farm was worth. The scientists told him his land was sour, acid, much in need of lime. Chemists told him his land was deficient in phosphorus. An occasional hoodlum of the community would tell him his land was bewitched, N. G. and that he should have gone West. But Adloff would look at them and in his raw, broken way he would tell them all: "Pff! You know nuttin'."

Adloff's farm contained some sixty acres, thirty of which was bottom land, the balance steep. One half the hill land was practically barren. The buildings were very poor and the fencing worse than nothing. There was no grass on the farm. The land had been corned and corned until King Corn so far as that farm was concerned was indeed a king of shreds and patches.

The first thing Adloff did was to borrow three hundred dollars from the bank, for which favor he actually paid the bank ten per cent. With this he bought a team, some tools, two cows and a few pigs and chickens, and then he went to work. He split rails and built new fences around the farm, hog-tight. He at once began sowing clover-seed. He saved all the manure possible from his stock and hauled many loads of manure from Rome-on-the-Ohio. He exercised a four-year rotation of corn, wheat, clover and clover with timothy.

The first year his crops were almost a total failure. He succeeded in fattening some sixteen head of hogs, and it is strange, but nevertheless true, that two weeks before they were ready for market fourteen of them died with cholera.

That year Mr. Adloff managed to pay the interest on his debt, but none of the principal. But he knew full well that there is no such thing as fail. The next year his crops were more bountiful and his hogs didn't happen to die this time. But Adloff didn't get out of debt the second year. He continued to build up the fertility of his soil. It was only a short time until he began really to prosper.

While Adam was building fence, sowing clover and hauling manure his wife was raising chickens and churning butter. It is a fact testified to by all the people of Stout's Run that this little woman who could not speak one dozen words of English peddled more eggs and butter to Rome than any other five women in the community. You would like to know her secrets of poultry management, would you? There are no secrets in the poultry business. Mrs. Adloff had two small chicken-houses, ten by fourteen feet, which she kept very clean. She read in "Folks' Friend," a German paper published in Cincinnati, that hens over three years of age would not lay to a profit, so she always kept young hens. She fed all they would eat twice a day, a ration of wheat, oats and corn. In winter she fed a mash at noon. She always kept about eighty hens on free range. And, of course, free range, and good feed meant vigor, and vigor meant eggs. Mrs. Adloff kept up a well-supplied table with her eggs

and butter. She also clothed the family of six and had four hundred dollars in gold when she died, which she saved from her sales of eggs and butter.

Of course Mrs. Adloff's success with poultry meant much to her husband. It gave him the money he earned to pay debts and improve with. It was only a question of a short time until he raised more hay on his small farm than all the other farmers on Stout's Run put together. His corn yielded twice as much to the acre as his neighbors'. On one measured acre of ground he raised eighteen hundred and twenty-five pounds of white Burley tobacco. A few years ago I had the old Adloff farm rented. The people talked so much about Adloff's acre of tobacco I thought I would try and duplicate it. So I measured off two one-acre plats, the plats being in different fields. One plat went two thousand pounds to the acre, the other fifteen hundred and some pounds. I sold the tobacco for eight cents a pound and with the proceeds purchased a small run-down farm, the story of which—if it be God's will—I will tell to the readers of FARM AND FIRESIDE in the future.

Yes, Adam Adloff succeeded in restoring a run-down farm to a high state of fertility and made a very good living all the while. At that, he was a man who made a multitude of mistakes. Had he taken the advice of the scientists and purchased some lime

and a bed of moss covered the fields, or perhaps the drier ground would grow a crop of weeds and daisies.

As for the rest of the farm, in the spring several acres of oats were usually sowed on land that had been in buckwheat the year before, with no manure or fertilizer, and timothy sown with the oats. Every farmer must keep a pair of horses and the farms were over-taxed to raise grain for them. Fifteen or twenty acres were in grain and only three or four at most could be manured, and no green crops turned under to make humus.

But there is a little awakening and improvement. People have begun to realize that it don't pay to do twenty dollars' worth of work on an acre and get fifteen dollars' worth of crops. Some ten years or so ago, we found out that lime would make clover grow when put on with a little manure. Here is our own experience on land farmed for seventy-five years in the way described.

About six years ago we began to use lime on heavy, wettish land, originally rather stony, but with a good depth of soil. On three acres plowed the fall before we put a light coat of manure, with one ton of air-slaked lime to the acre, sowed oats, and seeded to clover and timothy. We got a very heavy crop of oats and a fine growth of clover. The next year the clover had to be thrown out of the way of the machine every swath. We cut seven big loads of hay, and the year after six loads, mostly timothy. We have mowed five or six years, heavy crops every year.

Last year we tried lime without manure on a field of seven acres that had been idle for a year or so. We plowed in the fall and in the spring harrowed thoroughly, limed the land one ton to the acre, harrowed again, sowed clover and timothy (no other crop), went over with weeder to lightly cover seed and then rolled. The summer was very dry, but the clover lived. We got some rain in August and weeds came up on part. I ran the mowing-machine over this to cut the weeds and before fall the ground was green, and now (April 22d) it looks at a distance like a field of rye. This land was loamy soil and for thirty years had never had a bit of manure. It had been cropped to grain six or seven times and the balance of the time mowed.

We have not lived up to the possibilities in restoring land, I think. We have used all the clover for hay rather than for plowing under. It would be better never to mow the land more than one or two years. If mowed only one year, cut as early as possible and turn the second crop under and reseed to clover after only one crop, and keep on putting humus in the soil. Use lime and manure before each clover crop. If the soil lacks potash or phosphorus, it will pay to supply the deficiency with commercial fertilizer.

Remember, the soil is the farmer's bank. Don't be afraid to make deposits; this bank won't break and you can draw good dividends every year.

Cochecton Center, New York. S. V. BULLIVANT.

A Success in Kansas

WHILE living in Logan County, Illinois, six years ago I bought eighty acres of land three fourths of a mile from Hartford, Kansas. For three years I rented it out and still farmed in Illinois, but I did not get enough out of the rent to pay the taxes. The land was run down. So I sold out in Illinois and moved to Kansas three years ago this February.

The place had at one time raised lots of good corn and fruit. Now the corn-stalks were not over three feet high, but in one place the "horse-weeds" were tall enough to make stove-wood out of. I gathered a thirty-bushel wagon-box full of cockle-burs off twenty-eight acres.

To begin with, I put the stalk-cutter to work to cut what few corn-stalks there were, and hired a manure-spreader. I had either to move my barn or the manure-pile, so did the latter. I also hauled sixty loads from town; the owners were glad to have me take it away. Then I started my four-horse fourteen-inch gang plow six inches deep, turning up soil that had never seen daylight. It had been listed in corn for thirty years. The last time I rented it the man had not even broken

[CONCLUDED ON PAGE 4]

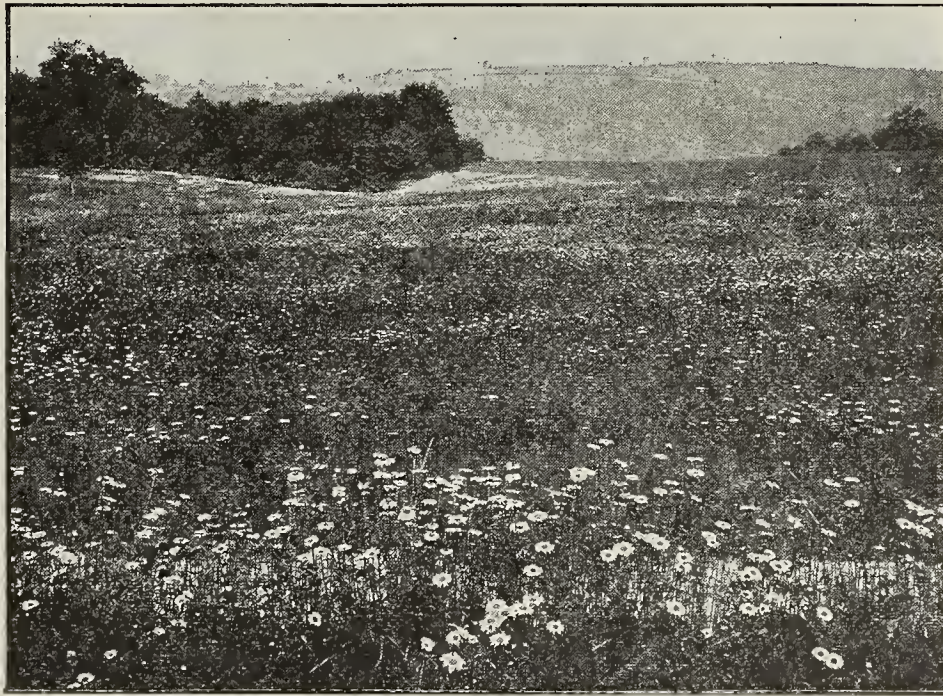

"The drier ground would grow a crop of weeds and daisies"
Photograph of Run-Out Meadow, taken in Central New York

to sweeten his soil and phosphorus to increase fertility more rapidly, it would have done much to hasten success. But he reached success finally by the systematic rotation of crops, and filling his soil with humus and nitrogen by the growing of clover and the application of manure. He fed the goose that laid the golden eggs; he fed the soil. Adam Adloff and his wife are numbered with the dead, but their farm is still producing bumper crops, and people round about still tell the story of Adloff's good farming and of his wife's four hundred dollars in gold.

Valley, Kentucky.

JNO. A. SHULTZ.

The Magic of Lime

IN THIS part of New York State (Sullivan County) there are not many abandoned farms, but there are a great many very badly run out, that no doubt would be abandoned if it were not for city boarders. The process of running out began as soon as the land was cleared. The settlers were poor and the land heavily timbered and rather stony. To clear up a farm was a slow and difficult task. Every one of the family and every acre of land as fast as cleared was taxed to the limit, and no thought given to feeding the soil. The manure from the stock generally went on a few acres for corn, making these few acres for the time fairly good, but the next year this land was sown to oats and seeded to timothy. The land had become acid and clover would not grow. This land usually was mowed until the grass ran out, and on most of the land that only took a few years. A little fine grass

What Happened at St. Louis

The Significant Points of the Farmers' Union Meeting—Reviewed by Francis Phillips

ONE feature of the May farmers' convention at St. Louis overshadowed all the others, the decision of the farmers to cooperate with the American Federation of Labor in fighting for legislation designed to be mutually beneficial. The experience of the farmers last winter at Washington, where they maintained official headquarters during the session of Congress, seems to have convinced them that only through the force of numbers can they hope to secure the consideration to which they feel entitled. Labor has long sought and been denied recognition in Washington. Through cooperation with the farmers they now see a chance of compelling the "plutocrat" and his lobbyist to yield to the superiority of numbers.

Everybody will concede that in point of numbers the tillers of the soil and the industrial toilers of the city represent a substantial plurality of the votes. These two wealth-producing forces welded into a concrete, homogeneous organization, conscious of its strength and intelligently directed, might dominate the legislative councils of the nation, if it so willed.

But isn't it a long way from realization? Samuel Gompers, President of the American Federation of Labor, who has cherished this union as one of the greatest ambitions of his life, doesn't think so. Neither does C. S. Barret, President of the Farmers' Union, who, following a series of conferences with labor's representatives at St. Louis, concurred in the compact.

All of the signatories to the understanding deny that it has any political significance. To the astute political strategist this is a mere quibble of words. Both Mr. Gompers and Mr. Barret say the agreement cemented at St. Louis contemplates a union of the two forces without respect to national political issues. Its sole aim and purpose they naïvely intimate is to force, through the superiority of numbers, such legislation as will tend to improve the condition of the country's wealth-producers and enable them to secure for themselves and their families a larger net return upon their labor than conditions heretofore prevailing have enabled them to get. In requital of the support given to the agricultural interests by labor in forcing recognition of its claims upon the country's law-makers, the farmers will back up the American Federation of Labor and its allied organizations in their demands for legislation that will better the condition of their members.

But suppose the legislation sought by two such powerful allies is not forthcoming? Suppose that the captains of

industry who control the big party machinery show their teeth to the new mastodon and defy it to do its worst? What then? It will be no idle task to dislodge the powerful men who now shape the country's legislative program. If these powers refuse to grant the demands made upon them by the allied farming and labor interests of the nation, will the producers stand and fight for the things they claim to be theirs of right, or will they curl their tails between their legs and run back to the sage-brush?

If the mood, discernible at the St. Louis convention survive the next harvest, such a challenge would mean a fight at the polls.

What Do People at Home Think?

Approximately three hundred and fifty farmers, from something more than twenty of the forty-eight states of the Union, attended the convention. President Barret makes the statement that these delegates represent three million farmers. There are four million other farmers not affiliated, but said to be largely in sympathy with the movement.

Before the significance of the movement to which the officers of the Farmers' Union and the officers of the American Federation have subscribed can be determined, the position of these seven million men at home, tilling the soil, must be fixed. Will they ratify the action of the farmers' convention and go with President Barret and his associates to the polls if needs be? If they do, it will mean the biggest political convulsion the country has experienced in years. About the attitude of the industrial workers in the cities controlled by the American Federation of Labor there is no question.

Whatever may be the outcome of the decision of the farmers to line up with the American Federation of Labor for their mutual benefit, it is apparent that the professional politician has his ear to the ground. Rarely before have so many men, conspicuous in the political life of the country, representing both great parties, sought an opportunity to speak to a body of men assembled in convention. In the course of the six days' session the delegates heard President Taft, Secretary of Agriculture Wilson, William Jennings Bryan, Governor Hadley of Missouri, former Governors Folk and Francis of the same state, Senator Owen of Oklahoma, President B. F. Yoakum of the Frisco railroad and a host of other notables.

A strong note of protest against the middleman was registered by speakers

from a dozen states. Various ways of dispensing with him were discussed by the delegates. O. F. Dornblaser of Cleveland, Texas, and R. D. Bowen of the same state advocated the establishment of state cold-storage plants and warehouses and the sale and distribution of their products by the farmers on the cooperative plan.

President Yoakum of the Frisco Railroad excoriated the middleman in a vigorous speech in which he cited specific instances showing how he got fifty-seven per cent, the farmer thirty-five per cent, and the railroad eight per cent, of the price paid by the consumer for foodstuffs. "The middleman is the curse of both producer and consumer," said Mr. Yoakum.

Through proper organization and cooperation he predicted the farmer could break the power of the middleman and improve his condition generally. A resolution calling upon Congress to enact legislation making it a crime to gamble in foodstuffs was warmly approved.

Alarmed by the expressed determination of the farmers to take action against the grain and produce speculating exchanges of the country, a committee from the various organizations dealing in these commodities, located in Chicago, Milwaukee and other places, bearded the men who would destroy them, in their lair during the week at St. Louis. The farmers appointed a committee to meet them and tell them face to face what it is about their operations they conceive to be inimical to the interest of the man of the soil. For two hours the grain-brokers and the delegates fought it out. When the grilling was over, the farmers had a good shade the best of the argument. They did not object, they said, to the middleman or the broker on the exchange as such, but they did object to the men of their kind who exact an unfair profit from the handling of farm products or gamble in the future of produce without ever intending to handle it at all.

West and South Heard From

President Wrightson of the California Fruit-Growers charged the Southern Pacific Railroad with getting the duty on imported lemons raised and then jumping the freight on the California product so as to absorb all of the benefit which the extra duty was designed to give the producers of that state.

Strong emphasis was laid by a number of the speakers upon the neglect of the government to provide for the drainage of the Mississippi Valley which, if made habitable, it was contended, would pro-

vide fertile farms for three hundred and fifty thousand families. A memorial to Congress asking for a substantial appropriation for this purpose was adopted.

Delegates from the cotton states took a firm stand for the use of cotton wherever jute, a product of India, is used. Recently the secretary of war, acting on an opinion rendered by Attorney-General Wickersham, issued orders that no jute must be bought for the navy where cotton would serve the same purpose. This decision was suggested by a similar stand taken two hundred years ago by the British admiralty to foster the development of the woolen industry of the United Kingdom, in which that nation now leads the world.

President Taft's speech did not come up to the expectations of the delegates; neither did the speech of William Jennings Bryan, because neither of them offered any definite plan for raising the standard of living of the American farmer. Both addresses diverged from the point and were full of the platitudes and generalities with which the assembled agriculturalists say they have been surfeited for years. While both speakers received a respectful hearing, neither had reason to feel satisfied that he had won the complete sympathy of his audience.

The delegates went to St. Louis with the notion firmly imbedded in their minds that they had legitimate grievances to remedy. For more than three years the country has been told by capital that the farmer has been cavorting about the country in automobiles and living a life of opulent ease. As emphatically as he could the farmer denounced this as a falsehood. His lot, instead of improving with the development of the country, has been growing steadily worse, he said, while the middleman who gambles upon the product of his labor is becoming steadily richer.

Upon one thing the delegates took issue with Secretary Wilson of the Department of Agriculture. The secretary urged the farmers to keep in touch with the Immigration Service so that they may secure men to work their farms and harvest their crops. The convention recommended to Congress the enactment of a law requiring immigrants to pay an income tax and pass an illiteracy and income examination, on the ground that promiscuous immigration will prejudice the farmer by flooding the country with a horde of non-producing men and women.

The announcement was made that the union would maintain headquarters at Washington during the next session of Congress so as to keep in touch with legislation.

New Life to Old Farms

[CONTINUED FROM PAGE 3]

stalks and had plowed all the ground only once and part of it twice. Each evening I would stop the plow in time to harrow up. When ready to plant the twenty-eighth day of April I had also done one crosswise harrowing.

I planted with a check-row planter and harrowed again in four days. The field was just like an onion-bed. The corn planted was pure-bred Yellow Dent brought from my Illinois farm. As it was four or five inches high, I ran the six-shovel cultivator fairly deep and close to the young corn, plowing the way it was planted and then plowed crosswise in a few days with the surface cultivator, using four long knives instead of shovels. That and the third plowing were not so deep or so close to the corn. We had roasting-cars the last week in July and I gathered forty bushels where no manure had been spread, and between fifty and sixty bushels as far as the manure went.

On the low land that had grown nothing but big weeds and cockle-burs I have seven and one half acres in alfalfa that gave two good cuttings in one season and a six-inch growth late in summer that made fine pasture.

I believe in fall or winter plowing. I cut as many of my stalks in fall as possible, then they give no trouble in spring work or cultivating. Good tilling and putting back humus, in the shape of cut stalks and weeds, and using manure even if you haul it a mile or so, and plowing deep enough to turn under the stuff, go a long way in just one season. Repeating these methods several years will soon give enormous yields. I believe the fifty-bushel box manure-spreader I

bought a year ago for sixty-six dollars has more than paid for itself twice over.

CHARLES B. CORBIN.

What Determination Will Do

MY EXPERIENCE in the buying of run-down farms covers a period of eight years. Starting with but little but a good wife and the determination to win, I bought a little farm of thirty-seven acres with no improvements thereon, paying for the land five hundred and twenty-five dollars. I went to work with a will to do the little things well. I worked—or, rather, we worked—and saved and improved for seven years, when a chance came to sell and we began to look for another farm. But with still limited means we could not look for the best. So, after some search, we bought the second farm—one that had been on the market for two years, so run down and dilapidated that no one would even bid on it. But after looking it over we made a bid that was taken up—seventeen hundred dollars for sixty-nine acres. We moved onto it in November, 1908, and went to work cutting thickets, cleaning out fence-rows, resetting fence, stopping gullies, etc., and making unsightly places look better. I plowed deep and sowed a crop of clover on one field, getting a good catch, and hauled out all the manure and rich dirt that we had time to handle. Our farm began to look as if there was a man on the place, so much so that in February, 1910, we were asked to price the farm which we did at twenty-five hundred dollars, eight hundred dollars more than we had given just a little more than one

year before. The buyer took the farm at that price. For the first farm we had received twelve hundred and fifty dollars or seven hundred and twenty-five more than we gave for it.

But let it be understood that I worked and tried to put a touch of work to everything that would look good to the eye of the passer-by. How well I did this the reader can judge by the difference in buying and selling prices.

On both these farms I have made more than a living, having stocked them with what good live stock they would carry. I have at all times kept high-grade stock, as scrubs are like poor run-down farms—no one wants them at any price that will be of any profit to their owners. No farm, rich or poor, can be kept up without live stock and legumes.

We have been married nearly fourteen years—worked a while with the other fellow, grew tired of that as we barely made a good living, bought the two farms as mentioned and began work for ourselves. It has been hard work, it is true, but we have the sweet satisfaction of calling the place where we stay our home, the sweetest word in all the world to the man that has one and made it himself. We have had some ups and downs, but we always looked on the bright side, read the experience of others and were stimulated by good agriculture papers such as FARM AND FIRESIDE. We pressed bravely on, with the result that to-day we could cash out if we so desired for somewhere close to four thousand dollars in money, with six children to boot, three boys and three girls, a happy and contented family. J. H. HARDISON.

Match, Tennessee.

"Well, There's Another Day"

IT IS more interesting to study the methods of the successful farmer than the unsuccessful. And yet we may learn by watching the man who is not making all he should from his land, find where he has failed and try to avoid these obstacles ourselves. We have had a chance to observe this matter on a farm that adjoins ours.

Several years ago this was the best-worked farm in the locality, part of it in woodland and pasture, the rest being of a deep sandy loam, which grew big crops of anything planted. There was a good log barn on the place, a tool-shed under which all the tools were kept and many smaller outbuildings. But since the present owner has come in possession, the buildings have gone to ruin, only the house being in good shape. Part of the barn has fallen in and the remainder seems about to do so, but still it must furnish scant shelter for the four cows and two horses kept on the place. The land, once so productive, barely furnishes forage for the stock.

And where has the owner failed? Not through ignorance so much as through lack of energy to put his knowledge to practical use. Of an easy-going nature, he is never in a hurry, puts in a few hours a day and the rest of the time is talking with the neighbors or at the corner saloon. So his work is always behind, and when the weather catches him with a piece half harrowed, that way it remains, his excuse being: "If it wouldn't have rained I'd been done with it, but oh, well, there's another day."

WISCONSIN. REINHART PROTENKAUER.

Harvesting the Billion-Dollar Crop

Helpful Pointers for Haying-Time—By M. Albertus Coverdell

WHEN once you begin haying, try to arrange so that you may give your whole attention to it till it is finished. Have all the odd jobs cleaned up—the corn laid by; the small grain harvested and under such protection that it will require no more attention until threshing-time.

Haying is another of those jobs in which a fellow should take his time while he hurries. The first day or two of the work, especially, should be slow and steady, in order to get everything started off right. Jamming and hustling the horses, machinery and men around usually incur so much breakage and useless expenditure of energy that one loses rather than gains by such proceedings.

One should be especially careful of the teams. Modern machinery has thrown almost all the heavier work of hay-making on the noble horse, and we are liable to overestimate his endurance. The teams will do more work, and stay in better flesh, if given a breathing-spell occasionally and allowed to cool off during the sultriest portion of the day. This is not only humane, but profitable.

The men, too, must carefully guard against buckling into the work and injuring themselves. It is an easy matter, when the heat is so intense, to bring on sun-stroke, and a man (or beast, for that matter) never fully recovers from the evil effect of a stroke, being able to perform but little physical labor or bear even moderate heat. The danger of rendering a man or his teams practically useless in hot weather for life is a matter not to be treated lightly, neither from a profitable nor a humane point of view.

To minimize the danger from sunstroke, allow the men a brief respite from their labors now and then. Give them time to wipe off the sweat, secure a fresh breath of air and a drink of cooling water. Shift the harness around over the horses and thus give them a chance to cool off. If water is available, unhook the teams and give them a cool, refreshing drink four or five times

a day, to maintain a more even temperature. Keep the water-jug sewed up in a damp gunny-sack or piece of carpet. Saw-dust, sand or hay, dampened and packed around the jug, helps to keep the contents cool and fresh, making it unnecessary to consume so much time in carrying water. Water so warm it is sloppy never puts much vim into a man.

The juice of a lemon squeezed into the water-jug not only adds to the refreshing qualities of the draft thus formed, but tends to allay the unnatural appetite for water which often causes one to drink so much that serious derangements of the body result. And don't pander to what is growing to be a too common and pernicious custom, that of furnishing so-called stimulants for the whole haying crew. Beer, ale and other intoxicants may stimulate the men for a short period, but the weakening after effect will more than counterbalance what is mistaken for a new lease of energy. Keep these deceiving drugs away from the haying crew, both for the sake of physical endurance and clean, temperate living.

And look here! Have you provided the women folks with sufficient help to manage the household affairs during the rush season? What with more sleeping-rooms to attend to, and what with standing over the hot stove preparing meals for ravenously hungry hay hands, the women folks have as strenuous a season of it as do the men, and it is only fair and right that the household help be increased. Then, a fellow had just as well be in early for supper, so the women can wash up their supper-dishes, get their other work all done and be in bed before ten or eleven o'clock. They will thus be more in readiness for preparing the next morning's hurry meal, besides getting a real night's rest. The men, too, can do up the chores in good time, care for the horses and get to bed at a decent hour. Even the horses are immensely benefited by such a plan. In fact, everything and everybody connected with the job will start in again next day with vastly more freshness and vigor after a full night's rest, so that one

actually gains in the amount of work accomplished if the job is not strung out into the evening.

Be sure that there are plenty of experienced men on the stack. You want the hay handled in such an efficient manner that it won't fall over and cause a rehandling; also, you want the bulge and slope that will shed rain properly.

If the hay is mown just after the bloom falls, its grass flavor and succulence will make it unnecessary to salt it as it is being stacked, but if cut when thoroughly ripened, salting helps make it palatable for the stock. Gage the amount of salt applied to the ripeness of the product, from a half-gallon to a gallon to the ton.

Stacks should be built—geographically, we might say—according to the direction from which the strongest winds usually blow. Here in northwestern Missouri most of the farmers run stacks northwest and southeast, so that the strong northwesterly winds will strike the end of the stack, but we consider that about as many strong winds come from the gulf section—the south and west—as from the northwest. Consequently, we prefer a stack built straight north and south. This puts it diagonally to both these classes of strong winds. Still another and even greater advantage of its being so situated is that both sides, which comprise almost the entire surface exposed, may receive the direct rays of the sun, and thus become dry within a short time after it has been rain-soaked.

If the weather is settled, it is an excellent plan to run the stack up to a pretty good point, then let it stand a day or two, putting on the permanent top after the stack is well settled. Where possible, the top should be slough-grass or blue-stem, as it affords the best of protection, and should any of it spoil, the loss will be comparatively slight. When finishing up a stack, we use a garden-rake to draw all loose straws from the sides and ends. This not only removes any bunches that may cling to the stack and hold water, but inclines the surface straws of the stack downward, forming an ideal

water-shed. We prefer long, light hangers to heavy ones, since the latter indent the sides of the stack, causing the water to collect about them, soak in and spoil considerable hay.

When the last stack is completed, don't drop everything and consider the job finished. With so much labor and expense attached to getting the hay up in prime shape, you'll want to see that none of it is damaged or wasted till winter feeding begins.

After an inspection of all stacks, to ascertain that none of the tops are leaning or have fallen over, take the stirring-plow and run a furrow around each stack, turning the dirt up against the hay. This furrow will catch the water off the stack and drain it away from the hay, thus guarding against dampness settling under the stack and causing mold.

Quite likely you'll pasture the meadow later on, and unless you take the time right now to run a substantial, three-wire fence around each stack, the chances are you'll put it off till the stock have eaten down the meadow pasture and wasted considerable hay in the stacks. Don't cobble up the fence and train the stock to crawl through into the hay, but make it stock-proof from the start.

Then, there is that stacker, the mower and all the rest of the hay tools that will need to be put under shelter. It takes but one time to do this, and by doing it now, the machinery will be easier taken apart and none of the scorching heat and fall rains will damage it. Leave all the bearings oiled to prevent their rusting before next haying season. It will even be advisable to replace missing bolts, burs or broken parts as you put the machinery away. You will find it much easier done now, while you have in mind what repairs are most needed, and it may mean a big saving to you next season. Again, it will pay you to shed the machinery in such a manner that those pieces which are needed first will be next to the door, so that they may be readily reached and run out when necessary.

Farm and Fireside's Headwork Shop

A New Wire-Stretcher



TAKE a strong piece of hickory, one and a half by three inches, about two feet long and taper into handle shape. Cut a two-and-one-half-inch slot in the other end from the handle, the slot to be a little wider than the size of the wire used. Place a thin iron plate over the slot, there being a corresponding slot in the plate, which is used to prevent the wire from cutting into the wood. Also screw or rivet to the handle a piece of thin iron (A) with a notch in it which fits over the wire (indicated by small circle) and prevents its slipping out of the slot. The lever is placed so that it bears against a barb, which keeps it from slipping along the wire.

Two men can do quick work with this, one stretching the wire and another driving staples. Or the stretcher can be handled by one man, who levers on the wire, swinging the lever around the post and fastening it in place, by a short chain and snap attached to the handle, while he drives the staple.

W. A. BROCK.

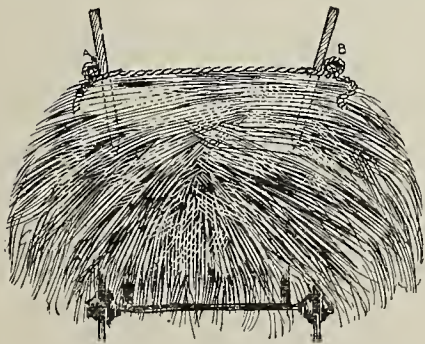

So the Load Won't Slip

TO PREVENT short straw or hay from slipping off when hauling large loads, I have never found anything equal to the following scheme: Take two light poles or boards the length of the hay-frame, and when the load is about two thirds on, place them on the load, one foot from the outside, tied to each other to hold them in place. Then take as many sharpened sticks as desired, about four feet long, and push them down, half their length, inside of and touching the poles. These form standards to load against, and when the load is finished and

WE WANT to make this "knack" page a frequent feature of the paper, and as an extra incentive to all FARM AND FIRESIDERS to help us in this we are going to offer three prizes of five dollars each for the three best contributions each time to the Headwork Shop, beginning with and including this issue. And all the other Headwork contributions we print will be paid for at our usual rates.

We are going to ask our readers to award the prizes by post-card vote. If one of the ideas in this issue strikes you as practical and helpful—a thing you can really use in your own work—won't you give the author the benefit of your indorsement on a post-card? Get into the voting and show yourself a Headwork Shop citizen, whether you are a man or a woman, so long as you belong to a family subscribing to FARM AND FIRESIDE and no one else in that family is voting. Always give name and address of subscriber to whose family you belong. Then just write the titles of the three Headwork articles in this issue that you think the best. Votes will be counted two weeks after date of issue. Won't you send us your choice right now, while it is fresh in your mind?

If you have a handy way of your own of doing something around the farm, why not write us a brief, boiled-down description of it, accompanied by a rough drawing if one is necessary to make it clearer. Address both votes and contributions to the Headwork Shop, FARM AND FIRESIDE, Springfield, Ohio.

EDITOR.

properly bound, it may be hauled a long distance over rough roads.

The ends of the lengthwise poles are shown, with the rope around them, at A and B. The parts of the sticks under the hay are dotted.

It is as simple and effectual in its way as a King road-drag. ALBERT MURPHY.

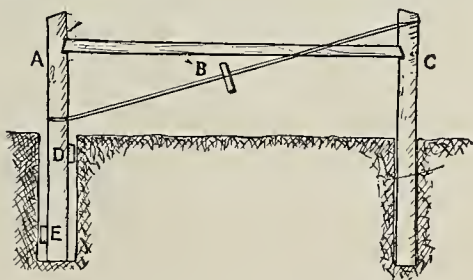

Firm Anchor Posts

THERE are a great many good and lasting ways of setting anchor posts. A great many farmers are using cement to set them in, which makes them admirably firm, but I believe I have a way of setting the anchor post that will do quite as well and that is less expensive. Dig the hole for the anchor post (A) four feet long and twenty inches wide or less, according to the size of the post, and four feet deep. Take two pieces of oak plank three and one half feet long, nail one of them (D) four inches from the top of the ground on the side of the post next to the brace post and the other (E) six inches from the bottom on the opposite side

of the post. Pack the dirt down good and solid. Set the brace post (C) ten feet from the anchor post. Put a good brace pole (B) ten feet long straight across from anchor post to brace post, twenty inches from top of posts. Then take No. 9 fence wire and put it around the bottom of the anchor post and the top of the brace post, taking it around twice, making it double, and twist as tight as possible. This makes a very good and firm way of setting an anchor post. C. F. KISSEBERTH.

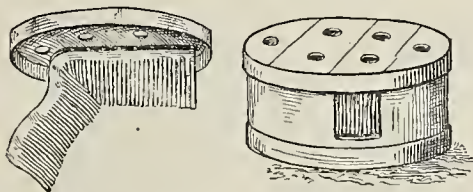

A Cheese-Box Brooder

SEVERAL flannel strips four inches wide are slashed every half inch and tacked in the lid, zigzagging back and forth, the strips close enough together so that the slashed ends hang down thickly over the chicks and make a warm hiding-place. In severe weather a warm rock placed on top will give the necessary heat. Holes should be cut in the lid for ventilation. Sand the bottom of the box to keep it clean. Turn the door in the side toward the wall at night to keep chicks in. This brooder is very useful when from ten to thirty chicks happen to be left on hand by accident. MRS. L. P. DUNCAN.

A Simple Door-Fastener

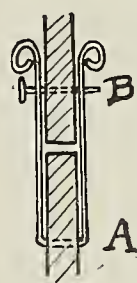

BORE a hole (A) in the door an inch or so from the edge. Now take a heavy, stiff piece of iron wire the size of the hole bored and about twelve inches long. Insert wire to about its center and bend it on either side of the door to form a U shape. Bend a loop in either end to give something to take hold of. Now lower the jaws of the U to clasp the door-jam (or the other door, when used on double doors) and make a rest or stop by driving a nail (B) under the wire when it drops to about a level.

The diagram shows it from above used on double doors. J. L. LAWSON.

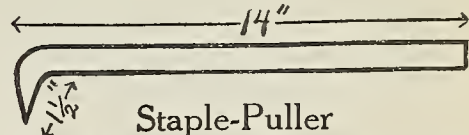

Staple-Puller

HERE is a simple and valuable tool for pulling staples out of fence-posts. Have the blacksmith make it out of a buggy spring. It should be about fourteen inches long and shaped as shown in the diagram, with one end bent and pointed. With this in one hand and a hammer in the other a man can pull staples quicker than any other way. D. CONGER.

Saving One Man's Work

LAST summer the illness of a neighbor caused me to take charge of his harvest and I found it necessary to economize both men and horses. The difficulty was to keep a mower going while we were hauling the cured hay to the barn. It was easy enough to draw the hay to the barn, with the remaining three horses; but the fork was rigged for two and it takes too long to use the "wheclers," besides, one was an extremely nervous colt.

Also, it was customary for one man to carry the spreaders and manage the team attached to hay rope, driving and turning them as required, with another man on load to "stick" the fork and trip it, and two good men in the mow. We had but three men available, and had to have two in the mow.

I managed by attaching the single leader—a mule—to the hay rope (wrapping the spreader to keep it from bruising her legs); then, climbing on load, I set the fork, just deep enough for a one-horse load, and by talking to the mule, caused her to draw it up while I "tripped" it. At first it was a little trouble to get her to turn and come around into position for another load; but perseverance won out. E. A. W.

Would 1/2 More Water

With the same power from deep wells **Interest You?**

It is accomplished with the Double-Acting

"American"

Deep Well Pump

It delivers full cylinder capacity both on the Down-stroke and the Up-stroke. It requires at no time more power than the up-stroke of a single-acting cylinder of the same displacement.

Send for the most complete deep well catalogue ever issued, No. 110 just off the press, mailed free.

THE AMERICAN WELL WORKS,

General Office and Works, Aurora, Ill., U. S. A. Chicago Office, - - First National Bank Building.

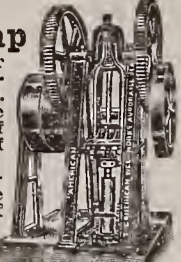

EVERY HAY GROWER Should Get This Great Free Book!

This valuable book—written by a man of 25 years' experience in hay—is full of live pointers. It tells how to save 20% of cost of baling—how to make smooth, neat bales.

Save 20% of Baling Cost

by using an Auto-Fedan Hay Press. We will prove this saving over any other press, right on your own ground, or take back the machine, paying freight both ways. Only two men required to run it. Three-stroke, self-feed, easy draft. Send for free book today.

THE AUTO-FEDAN HAY PRESS CO. 1507 W. Twelfth St. Kansas City, Mo.

Guaranteed **BLIZZARD** Ensilage Cutter

Sold on merit backed by 38 years' success. Proved strongest, most durable, smoothest running. Cuts green or dry feed and elevates any height. Knives adjustable at any time. Perfected construction throughout. Mounted or unmounted. Ask for free book, "Why Silage Pays."

Write for New Catalogue Free

Jos. Dick Mfg. Co. 1444 W. Tuscarawas St. Canton, Ohio

1 MAN HAY PRESS

With one horse you can bale a ton an hour with our wonderful Daisy. Self-feed, condenser, bar-sided hopper, and self-threading device, reduce hand work, increase baling capacity. Five days free trial. Write today for prices and testimonials. We have hundreds of delighted users.

GEO. ERTEL CO. QUINCY, ILL.

THE LARGEST AND BEST LINE OF **WELL DRILLING MACHINERY** in America. We have been making it for over 20 years. Do not buy until you see our new Illustrated Catalogue No. 15. Send for it now. It is FREE.

Austin Manufacturing Co., Chicago

The "EII" King of Horse and Steam Power **Balers**

A train of followers, but no equals. Proves its superiority wherever it goes. Makes tight shapely bales, not loose bundles, works fast, avoids accidents and endures. Little draft, tremendous power. The machine that makes competitors tremble. EII catalogue free.

Collins Plow Co., 1110 Hampshire St., Quincy, Ill.

ADMIRAL 2-MAN PRESS

3 FEEDS TO THE ROUND SELF FEEDER CONDENSING PACKER

ADMIRAL HAY PRESS CO. KANSAS CITY, MO.

Binder Twine 7 1/2 lb.

F. O. B. Melrose, Ohio, or Kansas City, Mo. Farmer Agents wanted. For samples and catalogue write Theo. Burt & Sons, Melrose, Ohio

LIGHTNING HAY PRESSES

Tested for over 25 years. Made in many styles. Horse Power, Belt Power and Self-feed Attachments. Simple and Durable with Greatest Capacity. They make a Profitable Investment. We can suit you. Write for Catalog and prices.

KANSAS CITY HAY PRESS CO. 124 Mill Street KANSAS CITY, MO.



VIRGINIA FARMS

As low as \$10 per acre along the Chesapeake and Ohio Railway. Rich soil, fine climate, abundant rainfall, convenient markets. Good schools and churches. No long, dreary winters, no cyclones and no droughts. Write for our handsome free booklet about VIRGINIA FARMS and low excursion rates. Address

G. B. WALL, REAL ESTATE AGENT. DEPT. K. F. CHESAPEAKE & OHIO RY. RICHMOND, VA.

Along the C&O Ry

Make Big Money with a Hay Press!

The **SANDWICH** Self-Feed, Full-Circle Press Coins Money for its Owners. WRITE QUICK FOR FREE BOOK!

There's a lot of good money in baling hay, if you have a big-capacity Press. \$6 to \$8 a day! Our Presses will bale more hay per day than any others—WE GUARANTEE IT! No trouble to clear working-horse-power barns or anywhere.

Sandwich Self-Feed Press has capacity of 12 to 18 tons per day! Fastest, Press on earth! Economizes help and power! Works at bank

We build all styles—Belt Power, Belt Steel Press, etc. Big Free Catalog tells all about them and "How to Coin Money With a Hay Press." Get busy—time is money! Write quick!

SANDWICH MFG. CO. 128 Main St., Sandwich, Ill.

Gardening---By T. Greiner

Still Planting Asparagus

THE last week in May I was still planting asparagus. A little late in the season, it is true, but not too late. My old bed was never wholly satisfactory. Plants were set too close and not deep enough. In consequence the bed has become so weedy that it is an everlasting job to keep it in half-way fair condition. I want it perfect, and I want large "fat" stalks which can be had only from plants that have plenty of room. I also prefer blanched, or "white," stalks, and these must grow underground. It is a good plan, any way, to make a new plantation every few years and have a thorough house-cleaning by plowing up the old bed.

I got hold of a lot of fine two-year-old roots and planted them in almost as simple a manner as potatoes are planted. I select a very rich piece of ground, of course, then furrow out rows as I would for potatoes, with my regular furrower, but five feet apart and going twice in a row so as to have a deep trench. Even then I dig a hole with the hoe for each plant, in the bottom of the trench at least eighteen inches apart (two feet would not be too much) and set the plants with roots nicely spread, then cover lightly with soil, afterward filling the trench partly by or wholly with fine old manure. Midway between rows, this year, I plant peas, early potatoes, cabbages or whatever may be desired, and give to the whole patch the thorough cultivation that we are in the habit of giving to such crops. We must head off every opportunity for persistent weeds to establish themselves in the new asparagus-patch.

In the fall another good coat of manure is given. In spring the rows are hilled up by plowing a shallow furrow to each row from each side, and the bed will probably be ready to yield a few good stalks early in the season. Cutting should cease, however, early in June so that the plants are not much weakened and will make a strong growth again. The old bed will be held, even if weedy, until about July 1st of next year, and then plowed up and planted to celery, turnips or winter radishes.

You will make no mistake if you start a new asparagus plantation, if plants can still be had. It is one of the most satisfactory of all garden crops, but an old neglected bed, overrun with weeds, is an abomination.

What Kills Belgian Hares?

W. T. W., a Washington (state) reader, who keeps Belgian hares, complains that the young, when about half grown, are taken with spasms and die. He wants to know what he can give them to stop the trouble, and where to get a book of instructions.

Years ago I used to keep large numbers of these interesting animals and I was quite enthusiastic about the possibilities I saw in them for raising cheap and fine meat. We had them on the table, cooked in various ways, and always liked our dish of "hare." In the beginning they seemed to be perfectly hardy and rugged, and the books told us that they were practically immune against

disease. We even let a large flock of them run outdoors, making their own living on weeds and grasses, etc., without hardly any help from us, and they thrived and multiplied.

After some years, however, troubles began. The young died off, one after another, litter after litter, usually when four to six weeks old, sometimes younger, sometimes older. But the real cause of this sickness has remained hidden to us. No book, no authority, has ever told us. We changed the feed, gave but little green stuff, especially of a very sappy or succulent character. We gave milk and omitted it, and tried everything. But it was the old story. The young were taken with the disease and died. So finally we gave it up.

This is not offering much encouragement for the inquirer. Probably there is something that could be done, if we only knew. There is also this chance that one of the many FARM AND FIRESIDE readers has learned the secret and can put us on the track of a remedy. If so, I hope he will inform us.

The Orange Judd Co. of New York has a small and cheap book on rabbits and how to manage them. I also have a small treatise, "His Lordship the Belgian Hare," written by A. M. Lambert and published by the Star Printing Co. of Jacksonville, Illinois. Price twenty-five cents. It gives remedies for various ills to which the Belgian hare is heir.

How to Handle Arsenate of Lead

Perhaps the paste form is not the most convenient shape for a substance that has to be dissolved in a liquid. Yet on the farm we have to do more disagreeable things, occasionally, than to dissolve the arsenate of lead paste. Thorough solution is essential. Many users think if they only throw a chunk of the paste into their spraying-machine, and do a little shaking or churning, the poison will soon be dissolved. Not so. You must first add a small quantity of liquid and keep stirring the paste and liquid together, with a paddle thus gradually turning the stiff paste into a sort of cream, and finally into a milky fluid, without chunks, and then it is safe to add to the spray liquid.

When I apply the poisoned liquid with a knapsack sprayer (as I always do in garden work), I often make the solution this way: Put the required quantity of arsenate (about three ounces for the three gallons of liquid needed for one charge of the knapsack) into a two-quart glass can and add a pint, more or less, of water or spray solution. Then violently shake, and keep shaking, the can until the solution is perfect. If there are a few lumps left, the milky fluid may be poured off, leaving the lumps in the can for some further manipulation and shaking up, a little more liquid being added.

When once dissolved, arsenate will stay in suspension or solution with very little stirring. When put on the foliage, it has great staying qualities, too.

More Complaints About Root-Maggots

Some more reports of root-maggot depredations have come to my table. Keep on fighting the enemy if it takes all summer. Apply whatever insecticide of the kind that kills by contact you may have nearest at hand—tobacco-tea, hot lye, kerosene emulsion, perhaps diluted lime-sulphur solution. Do it often and freely. But most important of all, stop breeding the pest. Pull up every infested radish, half-dead cabbage or cauliflower plant, turnip, etc., and destroy it, thus insuring the destruction of every maggot that is inside of the root and ready to turn into the fly which again deposits eggs that hatch into maggots within a very few days' time.

What is the Tea Vine?

A Salt Lake City (Utah) lady reader has vainly tried to eradicate what is commonly called "tea vine," which once grew on the spot where she built a new house and which continues to come up in the basement in spite of wood-ashes, hot lye-water and hoeing. She cannot get at it with the plow. Tea vine is probably a local name of the plant. I can't imagine what it is. Digging it out may be the only remedy that could be suggested, whatever it is.

How to Head Off Tomato Rot

A Tennessee reader has had trouble with his tomatoes. They made large vines seven feet high and set fruit freely, but when the tomatoes were about to get ripe, they commenced to rot.

It is a difficult problem. In some seasons we hardly have a sign of this black rot, black spot or blossom-end rot. Other seasons we have a good deal of it; usually on some varieties more than on others. The purple sorts are often seriously affected and the red ones often almost entirely free from it. The disease seems to be more prevalent on poor than on rich soil. I would not plant on very poor soil nor on excessively rich. Give the plants plenty of room and try different varieties. My early ones of the Earliana type have not been much affected.

Spraying with Bordeaux has often been recommended. I cannot say that I have ever seen a marked effect of its application in checking this malady. We have recommended pruning and training the vines to stakes or trellises, but this also does not afford much relief. Move the tomato-vines to another spot, when you plant another lot, selecting soil of at least fair medium fertility.

For the Potato-Beetle

Many who are gardeners incidentally rather than professionally are still holding to the idea that Bordeaux mixture is a remedy for potato "bugs" and other garden insects. It is true that this old standard mixture makes things somewhat uncomfortable for flea beetles, but it does not kill any insect, and potato-beetles and slugs will devour potato-foliage covered with Bordeaux and seem to thrive on it. Arsenate of lead is the thing. The advertising columns of agricultural papers give the addresses of dealers in that most effective of available poisons. Every big seed-house or supply-dealer can furnish it to you in small or big quantities. Use it in water, three pounds to fifty gallons, if you cannot do any better. It will clear out flea beetles and the potato-beetle nuisance. If you can get Bordeaux mixture just as well, better use it in place of clear water. If you have the concentrated commercial lime-sulphur solution, make some careful trials with it, diluting the solution with water at the rate of one to thirty, and add three pounds of arsenate to fifty gallons of the diluted solution.

Killing Mint Plants

Mint (it is not stated what kind) has taken possession of the ground around a Utah reader's bee-hives. He desires to kill it so as to avoid the necessity of moving his hives. A hard proposition! The plant is probably the common and extremely persistent American mint, often erroneously called "peppermint." Whether it can be killed with salt or chemicals such as iron sulphate or by spraying with diluted sulphuric acid, I don't know. I would dig the ground up and try to pull out all the roots and root stalks of the plants, then apply lime. Possibly some reader may know of a better plan and, if so, I hope, will report it.

Turnips may, and should be, sown by every farmer from now until August. The yield is very profitable and they are easily handled.

That small weed, overlooked and left right in the potato-hill at laying by, is the one that will sap the sustenance from the crop and be a giant at digging-time, which will also make digging more difficult.

Punch small holes in the sides and bottom of common cans, sink them in the ground—beside the cucumber-vines and pour in water to live up the plants about the time the cucumbers begin to set on, as the season usually turns dry about this time of year.

If the sweet potatoes are allowed to vine and the runners take root, the vitality of the plant is so lowered and the crop will suffer. Never allow the vines to get longer than a foot, or eighteen inches at most.

We use a screen frame sixty inches long and thirty inches wide for drying fruit. Swing the frame from two posts, throw a mosquito-bar over the fruit to keep off the flies, and the drying process will be uniform, both above and below.

M. A. COVERDELL.

Fruit-Growing—By Samuel B. Green

Elms from Seed

A READER in New Ulm, Minnesota, sends in a sample of elm-seed and asks how it should be treated to successfully grow young trees. I am inclined to think that all the elm-seed in his section was destroyed by the hard freeze this year, since it fell almost immediately after the freeze and there was hardly time before the freeze came to ripen it up. It is possible that some of this seed will grow; but after looking over considerable quantities of it, it does not appear to me to be in normal condition.

In a general way the best method of handling elm-seed is to gather it as soon as it falls. This can generally be done to best advantage where it falls on some clean surface, like a sidewalk or highway, where it can be easily swept together, and it should be sown at once in rather moist soil, in shallow rows about six inches wide, covering about one quarter of an inch and patting it down with the back of a spade or by rolling. If kept moist, the seed germinates readily and the seedling will generally attain a height of about one foot the first year, at the end of which time it may be transplanted to rows to grow until it is four or five feet high, when it should be again transplanted.

I see no objection to doing the light pruning of elms about the middle of June, but heavy pruning should be left until the trees are dormant and avoided whenever possible.

Walnuts in Oregon

J. T., Oregon—By French walnuts, I think you mean what we commonly call the English walnut. The hardy forms of this tree will undoubtedly grow in the Willamette Valley. However, the climate of Oregon is not well adapted to growing this nut to perfection, and there seems to be but a small area in this country, as well as in Europe, that can raise first-class commercial nuts.

I am not sure where you could get the hardier forms of the French walnut, to which I refer, but you could probably get them through Thomas Meehan's Sons, Germantown, Philadelphia. The best commercial form is too tender for your section. I am inclined to think that little would be gained by covering up the shoots of the walnuts when they are young, and that if they are tender when they are young, the chances are they will continue to be tender. Undoubtedly, you could protect them somewhat from the winter weather by wrapping with cloth. It is probable, however, that the reason these walnuts do not stand your winters any better than they do is on account of the moist weather which you have in autumn, which encourages late growth not conducive to greatest hardiness.

Killing Weeds on Walks

E. C. L., Duluth, Minnesota—There is a commercial preparation for killing vegetation on walks. I do not know where it can be obtained, but you can probably find out from the principal seed-stores and from park superintendents. You have at hand a cheap refuse from your gas-works that can be used for this purpose. Salt-water, if used at the rate of two pounds of salt to twenty-five gallons of water, would be entirely satisfactory. Quite likely more or less old fish-salt can be obtained in the vicinity of Duluth, which would be just as good as that of better quality.

Of course, the petroleum compounds are destructive to vegetation and also have the advantage of laying dust and forming a hard surface.

Red Cedar From Seed

N. S., Minnesota—Red-cedar seeds may be gathered at any time after they are ripe in autumn. I think it preferable to put them in potash lye for a few days, to loosen the covering, and then rub the seeds against a fine screen until the flesh comes off. Then mix with sand and keep them over until spring, burying outdoors where they will freeze. In the spring sow in beds about four feet wide, preferably in drills four inches apart, and cover with about one inch of hay to keep down weeds and to protect from drying out. The seed will not sprout until the spring of the following year, when they will start early and make a growth of four or five inches the first season.

Cedar trees three feet high, taken

from the woods, should be handled with care so as not to allow the roots to get dry, and the same rule applies to all of our coniferous seedlings. Plant them about one inch deeper than they grew in the woods and firm the soil carefully about them. Spring is the best time to move them.

Oyster-Shell Bark-Louse

Several subscribers have recently sent in twigs infested with the oyster-shell bark-lice. The accompanying sketch shows what the pest looks like. The scales are brownish, the same color as the bark to which they closely cling, and they are elongated, slightly curved and taper a trifle toward one end, so that they faintly resemble an elongated oyster-shell done in miniature.

This insect is extremely troublesome in some locations, and wherever it is found it should be removed from the trees as soon as may be.

The best time to treat the trees is in the winter when they are dormant, at



Oyster-Shell Bark-Lice on Apple Twig (Slightly Enlarged)

which time they may be treated with the lime-and-sulphur wash, which has often been referred to in these columns. Probably the best treatment to use during the growing season is to spray the trees thoroughly with strong whale-oil soap and water, just after the eggs have hatched out.

In the life history of this insect the eggs are laid inside the female, and if you will cut open some of these scales you will find them full of eggs. These will hatch in the early summer, and the young move about for a few days and then become fixed in place. It is while they are thus moving about that they are most easily destroyed, but it will require a thorough application of whale-oil soap to do it. On the approach of autumn, if it is found that there are still scales on the trees, they should then be sprayed with the lime-and-sulphur wash.

Bring Telephone Men to Terms

The law in regard to street trees varies greatly in different states. In several I believe there is no law restricting the cutting of trees along roadsides in opposition to the wishes of the abutting property-owner. On the other hand, telephone companies are often granted the right to use the roads for their poles and wires. In such cases, however, they have no right to interfere with trees that are preserved for their beauty, provided there is any reasonable way for them to string their wires without interfering.

In my experience, the telephone companies' employees generally go ahead and chop out as they see fit and expect the damage to be settled later or not at all, or trust to bluff to set the damage to one side; but if the owners of the abutting property put on a bold front and threaten injunction proceedings or damage suits, the employees are very careful how they go ahead.

The following instance came under my observation. A friend had a valuable row of cottonwood trees. The telephone company's employees putting up a new line said they were going to cut the trees down. He called me up, and I suggested that he keep them off with a shot-gun until he could get an injunction. The employees then offered to cut the trees up into kindling-wood if he would allow them to take them away, and finally they offset sufficiently to get by the trees without hurting them which they should have done to begin with.

Prunus Triloba

J. K., South Dakota—The Prunus triloba is, I think, nearer an almond than a plum. The common double-flowering form that we use for ornamental purposes does not produce any fruit with nut, but the single-flowering form will produce fruit very much resembling the plum.

I should be interested in knowing what you get from your crosses between the Compass cherry and the Red Siberian White almond, sent out by Professor Budd, to do very well when worked on the Sand cherry.

Marsh Ashes Poor Fertilizer

J. H. K., Illinois, states that two years ago a fire burned over his marsh, in some places burned as deep as four feet. He asks if the ash soil of the burned-over area would be good as a mulch for fruit-trees growing on high clay hills. Ash from marsh grass, sedges, ferns, brakes, rushes and similar plants has in it little of value to crops. It is sometimes advantageous to certain classes of land by improving their physical condition, but generally muck or peat from such land, that has not been burned is far better.

In our inquirer's region I think there is more profit out in Kieffer pears than in Bartlett, Seckel, Duchess or Anjou. Although the fruit is of inferior quality and sells at a low figure, yet on account of its greater productiveness it is more profitable.

Dwarf pears are sometimes used as fillers, but I should prefer them on their own roots. Dwarf pears have the distinctive merit of bearing young, producing a little fruit the second or third year after planting, but in my opinion they are not especially adapted to commercial orcharding.

A Problem in Reforesting

A. W., Hinckley, Minnesota—You state that a thick growth of poplar has come up in your vicinity since the great fire in 1894 and ask if it is practicable to set out evergreens among the standing poplar, with a view to having them come on ultimately as the forest crop. This is practicable, but only strong transplanted seedlings should be used. Weak seedlings are quite liable to be shaded out where the poplars are thick. The best evergreens to use are the native white pine or white spruce or the Norway spruce, all of which do well under such conditions. These should be grown from seed sown in a seed-bed and transplanted when two years old. This transplanting adds considerable to the expense, but is well worth doing.

Frost and the Honey Crop

A Wisconsin reader wants to know whether the frosts this spring hurt white clover and basswood. In my opinion neither of these plants has been seriously hurt by frost and they will produce their customary amount of honey.

Try This Experiment!

Although we make "Standard" and "Sisal," as well as higher grade twines, we have advised you farmers to use only the higher grades this year. Thus you will save money and discourage the present attempt of speculators to control the Sisal fiber market.

Prove for yourself that "Manila" is now cheaper than "Standard" or "Sisal" twine. Load your binder with "Standard." Count the number of bundles tied. Count the number of break-downs and the time you've lost.

Then fill your binder with Plymouth "Extra." Count the bundles tied. Count the break-downs (if any).

You will discover that Plymouth "Extra" ties more bundles, causes less trouble and costs less per foot than any "Standard" or "Sisal" twine. Plymouth "Extra" runs 50 feet longer to the pound than "Standard" or "Sisal" twine.

Plymouth "Extra" Twine

This twine first became popular because of its smoothness and strength, and because it runs more feet to the pound than "Standard." Now it has taken another leap. The fact that, at present, it costs less per foot than "Standard," has made it a universal favorite.



17 YEARS ON THE MARKET

THE WATERLOO BOY HAS ALL THE GOOD POINTS THAT GO INTO ANY GASOLINE ENGINE

5 YEAR GUARANTEE

All gasoline engines have some good points, or there would be no sale for them and they would soon be taken off the market. Some engines have more good points than others, that's why some engines are better than others.

WATERLOO BOY GASOLINE ENGINES

have all the good points that go into any gasoline engine, besides many exclusive, patented features that increase their efficiency and durability; make them marvels of simplicity and wonderfully economical engines to operate. That's why we say the Waterloo Boy is the best engine for farm use. You can buy a Waterloo Boy for less money than you will be asked for engines containing half of the good points we build into our engines. Besides we will send a Waterloo Boy to any responsible farmer and let him try it for thirty days on his farm, doing whatever work he has to do. We will pay the freight both ways and return his money if after a month's use he cannot pick out the good points for himself—if he can't see that it is the one and only engine that will give him complete satisfaction. Better write us today for our catalog and free trial offer.

YEARLY CAPACITY 15000 ENGINES

WATERLOO GASOLINE ENGINE CO. 173 W. Third Ave., Waterloo, Iowa

30 DAYS FREE TRIAL

CIDER PRESSES

THE ORIGINAL MT. GILEAD HYDRAULIC PRESS produces more cider from less apples than any other and is a

BIG MONEY MAKER Sizes 10 to 400 barrels daily, hand or power. Presses for all purposes, also cider evaporators, apple-butter cookers, vinegar generators, etc. Catalog free. We are manufacturers, not jobbers.

HYDRAULIC PRESS MFG. CO. (Oldest and largest manufacturers of cider presses in the world.)

126 Lincoln Avenue, Mount Gilead, Ohio

DON'T DIG WHEN IT'S QUICKER TO BORE IT

Standard Post-Hole Auger is the tool you need for fence work, tree planting, post-holes, etc., etc. Bore like a drill; dumps like a shovel. Get Our Free Catalogue 26 STANDARD EARTH AUGER CO.

1128 - 1134 Newport Ave., Chicago, Ill.

PATENTS PRODUCE FORTUNES

PRIZES for patents. Patents secured through us advertised without charge. New lists of inventions needed and possible buyers. "Hints to inventors." "Why some inventors fail." Book on patents. Send us rough sketch or model for search of Patent Office records and report on patentability. Special agents in 500 cities and towns. Mr. Greeley while Acting Commissioner of Patents had full charge of U. S. Patent Office. GREELEY & McINTIRE, Patent Attorneys, Washington, D. C.

PATENT YOUR IDEAS. They may bring you wealth. 64-page Patent Book Free. Fitzgerald & Co., Attys. Box N. Washington, D. C. Est. 1880

PATENTS Inventors Books free. Trade-marks registered. BEELER & ROBB, 22-26 McGill Bldg., Washington, D. C.

PLYMOUTH CORDAGE CO.

Entirely Independent.

No. Plymouth, Mass.

THE PRODUCT OF EXPERIENCE AND HONOR

CALDWELL SPECIAL—\$93.10

Money cannot buy a better 4½ H. P. gasoline engine than mine and I am ready to prove it as I want you to be thoroughly satisfied. Let me send you this engine, free of all charge. You may use it for sixty days—I'll even pay the return charges if you don't want to keep it.

Fully guaranteed for 5 years, but will last a life time and always give satisfaction. Try the Caldwell Special on your place. Write me.

CALDWELL-HALLOWELL MFG. CO.
525 Commercial St., WATERLOO, IOWA



Genasco Ready Roofing

made of real Trinidad Lake asphalt this way:

Cross-section, Genasco Smooth-surface Roofing

Trinidad Lake Asphalt
Asphalt-saturated Wool Felt
Trinidad Lake Asphalt

Look for the trademark and ask your dealer for the roofing that lasts. Guaranteed. Ask for the Kant-leak Kleet—the fastening that does away with cement in seams. Write for samples and the Good Roof Guide Book.

THE BARBER ASPHALT PAVING COMPANY

Largest producers of asphalt, and largest manufacturers of ready roofing in the world.

PHILADELPHIA

New York San Francisco Chicago

Send Name for Book of Over 125 Buggy Bargains

BIG BOOK—in colors—including 1910 Split Hickory Auto-Seat Buggy and over 125 latest style vehicles and harness, direct from my factory—made-to-order—30 Days' Road Test—2 Years' Guarantee.

Save \$26.50 or Up

Prices all astonishingly low—vehicles shown in colors from photographs. Don't buy before writing me for sure cash savings.

H. C. Phelps, Pres.
The Ohio Carriage Mfg. Co.
Sta. 23, Columbus, O.



"RANGER" BICYCLES

Have imported roller chains, sprockets and pedals; New Departure Coaster Brakes and Hubs; Puncture Proof Tires; highest grade equipment and many advanced features possessed by no other wheels. Guaranteed 3 yrs. direct to you.

FACTORY PRICES are less than others ask for cheap wheels. Other reliable models from \$12 up. A few good second-hand machines \$3 to \$5.

10 DAYS' FREE TRIAL We ship on approval, freight prepaid, anywhere in U.S., without a cent in advance. **DONOTBUY** a bicycle or a pair of tires from anyone at any price until you get our big new catalog and special prices and a marvelous new offer. A postal brings everything. Write it now.

TIRES Coaster Brake Rear Wheels, lamps, parts, and sundries half usual prices. Rider Agents everywhere are coinng money selling our bicycles, tires and sundries. Write today.

MEAD CYCLE CO., Dept. C-83, CHICAGO



Make Your Bicycle Into a MOTORCYCLE

at small cost by attaching the **ERIE MOTOR**. This includes all parts so that anyone can make a strong, durable machine that will climb steep hills and run for 4¢ per mile. 1,000 in use. Sample sold at cost. Send 2¢ stamp today for catalog & MOTORCYCLE EQUIPMENT CO. Hammondport, N. Y.

WHY PAY BIG PRICES for stove linings? We will send you enough prepared clay for two stoves for 50 cts. Lasts twice as long. Gives better satisfaction. Wgt. 20 lbs. Money for boys to take orders. Write

JOHN PLUMMER, Courtney, Pa.

GEM CITY Business College

Quincy, Ill.

25 teachers, 1400 students, \$100,000 School Building, Shorthand and Typewriting, Bookkeeping, etc. 83 page Illustrated Catalogue free.

D. L. MUSSELMAN, Pres't
Lock Box 14 Quincy, Ill.

It is to your advantage to mention Farm and Fireside in writing to advertisers. Farm and Fireside folks get the very best attention.

"BRECO" Freight Prepaid

Rubber Roofing Don't think of using any kind of roofing till you test sample of old reliable Guaranteed "BRECO." Why pay more? Investigate, and you will order here today.

BOOK AND SAMPLE Free

Book proves and shows testimonials of Breco Service. Waterproof and fire-resisting qualities. Cement and nails free. Write today.

The Breese Bros. Co., Roofing Dept. 24, Cincinnati, O.



Practical Poultry-Raising

Better Hatch Late Than Never

LAST fall the wife of an Indiana farmer wrote me that she was going to be short of winter pin-money because she made a failure of her poultry-raising the past summer. She said, "John does not kick about the food the poultry eat, but when it comes to handing cash to me I can see plainly that it goes against the grain. I have all the poultry money, but it will be a scarce article this fall and winter."

She told me she had missed out through losing nearly all of her early-hatched chicks during the cold, rainy spring. A "cloudburst" destroyed most of her second hatches and summer found her with very few chicks to raise—not more than was required for the table when company came. Then she quit, because she had frequently read that chicks would not do well in midsummer weather. That is where she made a mistake. Many people think it is a prime idea to hatch out a lot of chickens in February and early March, to get on the early market and get ahead of their neighbors. When the expense and trouble of raising these early chicks is closely figured, the profits show up exceedingly slim, even if there are any.

Raising early chicks in paying numbers with the fixtures found on the ordinary farm is not what it is cracked up to be. At that time of the year eggs are worth a good price and I have always found it good policy to let them go and get the price in my pocket, and let the other fellow court the vexation and expense of converting them into broilers.

In the matter of raising summer chickens, when one misses out in the spring, one should not hesitate a moment to push right into it. I have raised thousands of them at a much greater profit than is possible, taking expense, trouble and loss into account, from early broilers produced on the ordinary farm. Then because one fails with spring hatchings is no reason why he should not stock his yards with June, July and August hatchings. Of course, one will miss out on fall and early winter layers, but he should have first-class layers by February.

One season I had two hens come off the first and third of August with fourteen and sixteen chicks. I put all of them with the quietest hen, in a coop with large run attached, in what we call the back garden, clear away from all other fowls and chicks. They were fed twice a day the first week, and after that their feed-hopper and water-fountain were filled once every third day and they took care of themselves. At the end of three weeks the hen was removed. After the middle of September the chicks were confined to the coop and run at night, and, except in stormy weather, were let out in the morning. The tenth of October they were brought to the poultry-house, and at that time their average weight was three pounds and two ounces. Six of the pullets which were kept began laying the second week in January.

Last year a farmer's wife living about eight miles distant called me up on the telephone soon after a storm that was almost a flood and informed me that she had lost nearly all the chicks she had. That was the middle of June. I told her to get out some more hatches as soon as possible and to keep on setting hens up to the middle of July. She did so and in early August had a few over three hundred chickens. The hens were given twenty to twenty-five each as they were hatched. After the first week of their lives the chicks had all the food they could consume, with an abundance of water, some milk and plenty of oyster-shell. The hens were removed at the end of ten days, and the chicks were confined to the coops and runs whenever the weather was threatening. It does not injure chickens so much to get wet when they are brooded by the hen, but when they are brooding themselves they must be protected until they are well feathered.

These chicks reached an average weight of two pounds at eight weeks of age and then they were fed once a day a soft mash of milk and meals, in addition to their regular dry food. In a short time they weighed three pounds each, when all were sold, except eighty pullets, the best in the lot. Those sold brought a little over eighty dollars. The pullets kept over began laying early in February, and their owner said she got more eggs from that lot of pullets than she ever did from a much larger flock of fowls of all ages.

Poultry-raisers should not for one moment be discouraged if through mis-

management or accident they lose their early hatchings. Many times I have advised farmers and their wives not to be in too big a hurry with their spring hatching. Wait until the frosty nights are gone, then the little fellows will find young grass and clover ready for them, and they will often make better fowls than those hatched earlier, because they are never checked by being chilled. That is, if they are given reasonably sensible care. Mites and lice often work havoc among them, mites being fifty per cent. more destructive than lice. The coops, if they are in coops, ought to be sprayed once a week and if the coops are moved to new ground after each spraying these pests will never trouble the little fellows.

FRED GRUNDY.

Ducks are Meat-Eaters

WHEN the ducklings begin to give evidence of an appetite, usually when about twenty-four hours old, I give them crumbled bread soaked in milk, with water to drink. They get this four or five times a day. After a few days I mix in a bit of meal and wheat-bran, and gradually get them off onto a mash of equal parts meal and bran, with a little sharp sand stirred into it. This diet, be it understood, is for ducks that have complete liberty to find what animal and vegetable food they like. If ducklings are confined, they must have a balanced ration, with a liberal percentage of meat-scraps.

In summer the old ones prefer the food they get from the water—worms, fish, snails, mollusks, polliwogs, etc. Mine will eat but once a day, when the weather is such that they can get to the river on the flat below the house. When they return at night, they will ask for something to eat. Then I give them all they will eat of whole corn. They seem to lay best on this, as they balance it up with the animal food and green stuff they get during the day.

But clear corn or meal will not do for little ducks. There is not enough bone matter in it or growing material. Soon you will see they are not thriving, and they may get leg weakness and other troubles. The animal or meat element in the diet of ducklings is much more essential than in that of chicks, though the latter plainly show the effects if it is taken away from them.

Ducks can be reared successfully in confinement without water other than for drinking purposes (though I doubt if they are ever really happy so). But then you must furnish them a grain ration balanced with animal food and green stuff, with plenty of grit.

The Geneva Experiment Station has found that ducklings can eat without injury, rations over ninety per cent. of which is of animal origin. Of course, the cost was high. They also found that ducklings fed a varied and palatable grain ration, well balanced so far as the commonly-considered nutrients are concerned, but without animal protein, turned out badly. Half of them died before four weeks old, and the others were only saved by the addition of the needed element to their food.

Next they experimented to find the most profitable amount of it to feed. It was found, that until five weeks of age the ducklings grew most rapidly upon a ration containing sixty per cent. animal food, while the cost per pound of growth was as low as any. As the birds grew larger the advantage of the high proportion of animal food lessened, until reduced to twenty per cent.

We once left home for a time just after taking off a large hatch of ducklings. Those left in charge confined them in a small yard and disregarded feeding directions, considering it foolish to cater to the special appetites of young ducks. They were fed clear corn meal mash. Soon they began dropping off by the half-dozens. I returned in time to save a handful, but they were hardly worth it, thin, weak and unevenly developed.

E. G. FEINT.

An Attic for Chicks

HERE is a scheme for starting chicks that has given me first-class results. I never let them out until they are a week old. I have no house and keep them in an attic with a window in it. I took some boards and made a tight floor and nailed boards around the sides to keep the chicks from falling down in the walls. This floor is divided by another board a foot high. If I have bad hens, I put netting up to the rafters to keep them apart. All my newly-hatched chicks I put up here and they are out of

the way and weather until they are strong. If it should rain after they are a week old, I still keep them there.

I give each hen a shovelful of grass with earth on it to scratch and so the little ones have some sand right away. I change this about every three days. As the chicks grow older, I bring them down in clear weather. If they are strong and it stays clear, I keep them down to make room for others.

I always give my chicks rice for the first feed with a little bread soaked in milk or water once in a while—not too much because it makes gas in their crops. Later they get other feeds, but I keep up a little rice (not cooked) until they are well feathered.

Last week a neighbor had some chicks with gas in the crops. They rolled over backward as if they had the fits. I told the owner to give them only rice a while and let them out where there were some ashes with charcoal in them. The chicks all lived and are growing strong.

M. STRAUSS.

Liver Trouble of Turkeys

LIVER trouble is one of the most common diseases turkey-raisers have to contend with. It is usually brought on by overfeeding. If the digestive organs are overloaded, part of this food decays before it has time to digest, which is as dangerous to health as food decayed before eating. Birds from two to eight months old are usually affected. Some are taken very suddenly, while others droop around for several days and then die. This trouble is not considered contagious, but after it gets started in a flock there are very few remedies that will do any good. In old birds, if the disease is not in an advanced stage, a teaspoonful of castor-oil once a day for two or three days followed by a dose of quinine—a pill of one half to one grain strength—has been tried with good results. Young birds very seldom recover under any kind of treatment. In fact, there is nothing more unsatisfactory than to try to doctor a sick turkey of any kind.

To prevent liver trouble among turkeys, then, one should be careful in feeding them. In their present semi-domestic condition they should not be pampered or overfed. Remember, in their wild state they ran about here and there seeking small grains, seeds and bugs, getting plenty of exercise as well as food, the exercise being one of the most important factors in successful turkey-raising.

A. E. VANDERVORT.

Rye for Hens

A FRIEND asks how much value there is in rye for feeding hens.

We never have considered rye a first-class feed for poultry and have not, therefore, fed much of it. Rye does not contain as much protein as wheat, neither has it as much fat in it by a considerable per cent. Indeed, the feeding value of rye is not more than two thirds as great as that of wheat, their nutritious qualities being in the proportion of not far from sixty-four to seventy-one. We all know that bread made of rye is apt to have a stickiness that many do not like. In that form it is rather more laxative than wheat. And when attacked by ergot, as it sometimes is, it is really poisonous.

Rye is rarely mentioned in the tables of rations given by the best poultrymen and it is the experience of the writer that as a grain for poultry it is in not very great favor.

E. L. VINCENT.

A good way to have all the chicks on hand at meal-time is to feed at regular hours.

Wet grass in the morning, even in warm weather, is injurious to the chicks. Close the coops each night and keep them closed until the dews have dried up.

Ever try to hurry a bewildered hen and chicks into a coop when a shower threatened? They didn't hurry worth a cent, did they? Give them a little time and they can be gotten in sooner.

Everybody fattens hogs, cattle, horses and sheep before marketing them, but how many farmers did you ever see fattening their chickens for the market? And why should they not be fattened?

The big and little chicks should not be permitted to roost in the same coop, as some of the smallest ones may be smothered. It is also best to feed them separately. Otherwise the big ones will trample over the little ones and gobble up the biggest part of the food.

Live Stock and Dairy

A New Test for Dirt in Milk

A quick and easy method for determining whether milk is clean or not, when delivered, has long been needed. Every cheese-maker knows, and every farmer who delivers milk at a cheese-factory should know, that clean sweet milk is the most satisfactory for cheese-making and also the most profitable. The yield of cheese from unclean milk is usually lower and the cheese is of a quality that does not command the highest market price. The best grade of butter cannot be made from inferior milk or cream. Dairymen who supply milk to the city trade find that a layer of dirt settled in the bottom of the milk-bottle will do more to make a customer dissatisfied than almost anything else.

The importance of this matter to the pocket-book of both farmer and middleman has long been recognized and many

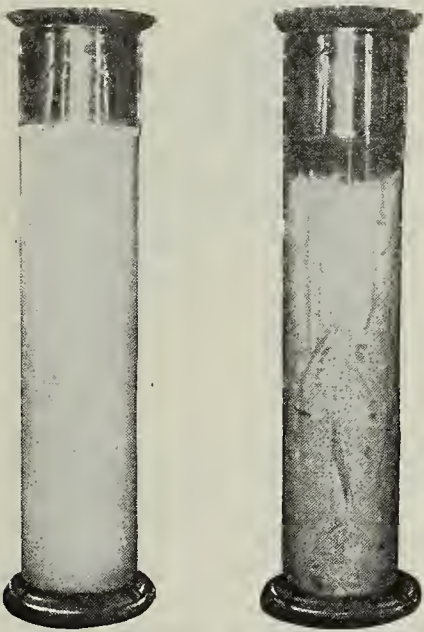

Fig. 1—Curds From Clean and Dirty Milk

inventions have been put on the market for keeping dirt out of milk or for removing any dirt present before the milk is sold. Milking-pails can be bought with a cover and a small opening at the top, which keep out most of the falling dust. It is often recommended that the cow's udder and flanks be freed from loose dirt or hair by use of a whisk-broom or a damp cloth just before milking. A milking-shed, where the cows and milk are protected from the wind and flying dirt and where there is no dust from hay or other dry feed, is a recognized necessity. In some parts of Europe milk which is to be bottled is first run through a centrifugal machine for removing any dirt that may have gone through the strainer.

Whatever else may be done, the milk-pails should be carried to the milk-room as soon as filled and the milk should be strained at once. So generally are strainers used that a farmer who does not strain the milk he sells would probably be ashamed to admit the fact to his

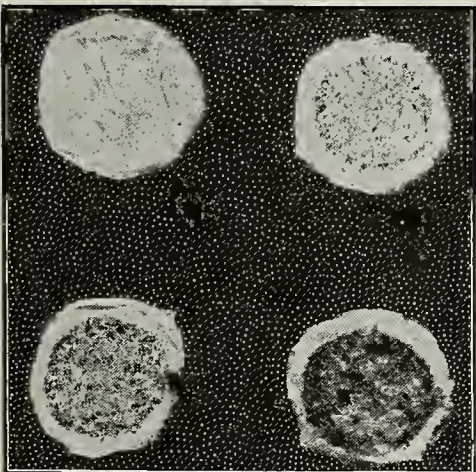

Fig. 2—How the Test Shows Degrees of Dirt

neighbors. A strainer of metal holding a cloth or a wad of cotton batting for the milk to pass through is the best. A poor strainer may give a false sense of security and do more harm than good. A worn-out metal strainer or one with large holes in it should be thrown away or else repaired at once.

Several tests have been devised for use in creameries and cheese-factories to detect which lots of milk have not been properly taken care of. Unclean or dirty milk will usually get sour faster than ordinary. When such milk thickens, the curd will contain gas bubbles or will de-

velop a foul odor or taste. The solid curd in the glass cylinder on the left was obtained from perfectly clean milk, while that shown on the right contains many gas bubbles and is wheying off rapidly (Fig. 1).

The fermentation tests used in Europe and the Wisconsin Curd Test for unclean milk work on this principle. But these tests, while very effective, require that the samples of milk examined shall be kept several hours before the test is completed. A test is needed which can be applied quickly to every lot of milk as it comes to the intake.

The sediment test works on the same principle as the best milk-strainers, and it is so rapid that the dirt found in any sample of milk can be shown to the patron before he leaves the factory. Several different sediment tests have been used in Europe, and a new and convenient form has recently been devised by Professors Babcock and Farrington at the University of Wisconsin. The apparatus is simple. It consists of a funnel-shaped metal vessel (A), having a loosely-fitting cap (C) at the bottom, which is held in place by the clamp rod (D). This cap contains a circle of wire gauze (E) over which is placed a small strainer of cotton felt which is furnished with the outfit. A pint of the milk to be tested is then poured in at the top of the apparatus. The milk quickly runs through the cotton filter, which retains any dirt which may have been present. The filter disk is then taken out and shown to the patron; or it may be spread to dry on a piece of paper, on which the patron's number is written. Another filter disk is put into the apparatus and another sample of milk is tested. The tester is double-walled and is kept warm by running steam or hot water

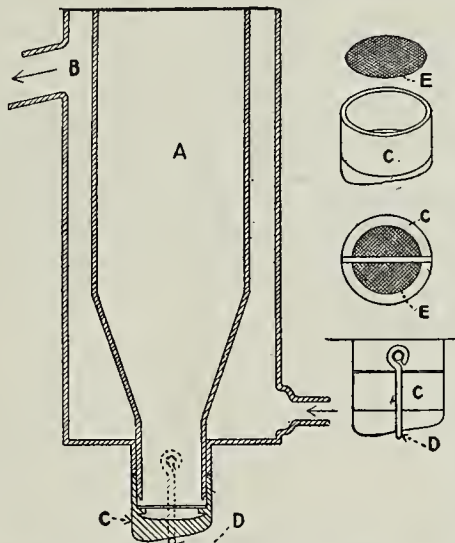

Fig. 3—Construction of Sediment Tester

into the jacket (B). This is necessary because cold milk filters slowly. By keeping the tester warm, milk samples can be tested as rapidly as the milk is received and weighed.

Four different lots of milk contained varying amounts of dirt as shown in Fig. 2, and were graded as:

First, perfectly clean; second, slightly dirty; third, dirty; fourth, very dirty.

Milk which has been run through a strainer on the farm will often contain an amount of dirt when delivered that will surprise both the patron and the factory man. This may be due to the use of a poor strainer or to exposure of the milk after it was strained. In either case, the sediment test will detect the condition of the milk. A few days' use will show plainly which patrons are keeping the milk clean and which should use more care in handling it.

The milk sediment test can be conveniently set up near the intake, at the factory.

PROF. J. L. SAMMIS.

Not Serious Vice

A VIRGINIA reader has a nine-year-old mare which has always been gentle until lately, when she has taken the trick of kicking up her heels dangerously close to the dashboard when another horse happens to be passing on the road.

The best treatment in such a case is to put on the "controller" as described in my article on treatment of vices, April 25th, and apply pressure whenever the animal kicks. If, as is probable in this instance, the kicking is only playful, do not use the controller too harshly—a very little treatment, I think, will suffice. Put on the controller several times, applying pressure only when she kicks and at no other time, and discontinuing its use entirely as soon as the habit is cured.

DAVID BUFFUM.

A JUNK PILE MOUNTAIN OF VERY EXPENSIVE CREAM SEPARATOR EXPERIENCE



(A sample pile of scrapped competitive separator bowls—the frames being broken up in the field to save freight on same.)

During the year 1909 more than 10,000 enlightened and disgusted American users of poor or wornout competitive makes of separators threw them aside and replaced them with new

DE LAVAL CREAM SEPARATORS

on top of 8,500 having done so in 1908, 7,000 in 1907 and 5,000 a year for several years before, or at least 50,000 within ten years.

If it were possible to put these 50,000 machines into one huge "junk pile," as they have in fact gone into a thousand "junk piles," it would make a veritable mountain of cream separator experience, as impressive as Pike's Peak and representative of as much costly acquired separator experience as though it were a great mine of gold or silver.

These 50,000 "near" and "just as good" cream separators cast aside to be replaced with De Laval machines within ten years, and so many of them within a couple of years, cost their users at least three and one-half millions of dollars in the first place and probably wasted three times that much in quantity and quality of product, excessive repairs and excessive time required to put the milk through them while they were used, or a total of at least fifteen millions of dollars, and more likely twenty-five millions.

What has happened in America in this way has in the same time been doubled throughout the rest of the world, so that the total aggregates twice as much, or perhaps fifty millions of dollars. And worse still, this accounts only for those users who have recognized the facts and remedied them. There are thousands more users of inferior separators who have yet to do so, and unfortunately some yet embarking anew on this expensive separator experience of their own.

These figures are monumental, but they deal with a problem of enormous importance to everyone who has cream to separate from milk, which the average man can better appreciate put in this collective way than he can when applied to himself alone, though it means exactly the same thing one way or the other.

The facts are all capable of proof to the man who cares to have them proved and who doesn't want to contribute at his own expense to this enormous and ever-increasing "junk pile" mountain of cream separator experience, or, better still, to the man who has been doing so and thinks it about time to stop.

To such owners we would say that the De Laval Company will this year continue its "trade allowances" for these old machines, because of the opportunity such exchanges afford in an educational way for the most practical illustration possible of the difference between good and poor separators, and thus putting a stop to the sale of others like them in the same neighborhood.

Any desired "trade allowance" information may always be had of the nearest De Laval local agent or of the Company directly.

THE DE LAVAL SEPARATOR CO.

165-167 BROADWAY
NEW YORK

42 E. MADISON STREET
CHICAGO

DRUMM & SACRAMENTO STS
SAN FRANCISCO

173-177 WILLIAM STREET
MONTREAL

14 & 16 PRINCESS STREET
WINNIPEG

1016 WESTERN AVENUE
SEATTLE

United States Cream Separators

Save \$12 to \$20 per Cow
EVERY YEAR OF USE
Over all Gravity Setting Systems
And \$5.00 to \$7.50 per Cow
Over all other Separators
Holds World's skimming Record
Won Grand Prize, Seattle, 1909
Write for Catalog 69—It clearly explains everything
VERMONT FARM MACHINE CO., Bellows Falls, Vt.

NEWTON'S HEAVE COUGH, DISTEMPER AND INDIGESTION CURE

The Standard Veterinary Remedy.
20 years sale. Send for booklet.
SAFE TO USE
BEST CONDITIONER
Makes the horse sound, stay sound

DEATH TO HEAVES

The first or second \$1.00 can cures. The third can is guaranteed to cure or money refunded.
\$1.00 per can at dealers, or express prepaid.
THE NEWTON REMEDY CO., Toledo, Ohio.

ABSORBINE

Removes Bursal Enlargements, Thickened, Swollen Tissues, Curbs, Filled Tendons, Soreness from any Bruise or Strain. Cures Spavin Lameness, Allays Pain. Does not Blister, remove the hair or lay the horse up. \$2.00 a bottle, delivered. Book 1 D free.
ABSORBINE, JR., (mankind \$1.00 bottle.) For Synovitis, Strains, Gouty or Rheumatic Deposits, Varicose Veins, Varicocele, Hydrocele. Allays pain. Book free.
W. F. YOUNG, P. D. F., 284 Temple St., Springfield, Mass.

HARVEY BOLSTER SPRINGS

Soon save their cost. Make every wagon a spring wagon, therefore fruit, vegetables, eggs, etc., bring more money. Ask for special proposition. Harvey Spring Co., 729 17th St., Racine, Wis.
FREE TRIAL TO YOU

WHEELS, FREIGHT PAID \$8.75
for 4 Buggy Wheels, Steel Tires. With Rubber Tires, \$15.25. 1 mfg. wheels 3/4 to 4 in. tread. Buggy Tops \$5.00, Shafts \$2.00. Top Buggies \$38; Harness \$5. Learn how to buy direct. Catalogue Free. Repair Wheels, \$5.50. Wagon Umbrella raze. F. F. BOOB, Cincinnati, O.

PATENTS WORTH FORTUNES
Inventors: Send 6 cts. for our Valuable Patent Books
B. S. & A. B. Lacey, Dept. 49, Washington, D. C. Est. 1869

LEARN TO WRITE IF YOU ARE EARNING
ADVERTISEMENTS LESS THAN \$25 A WEEK
we can positively show you by mail how to increase your salary. Send for beautiful prospectus, mailed FREE.
PAGE-DAVIS SCHOOL, Dept. 25, Chicago, Ill.

SOUTHERN MANITOBA FARM SALE, three quarters level, improved, every foot tillable, 400 acres tame hay and crop, \$30.00 an acre with crop. Three quarters level prairie at \$15.00. Close in. Easy terms. R. E. WARNER, Kulm, North Dakota.

It is to your advantage to mention Farm and Fireside in writing to advertisers. Farm and Fireside folks get the very best attention.

Try My Litter and Feed Carriers, Stanchions and Cow Stalls at My Risk

My barn equipment is sold under a positive guarantee of perfect satisfaction, whether you purchase one stall or a hundred. You can't make a mistake in ordering
JAMES FEED AND LITTER CARRIERS, STANCHIONS AND COW STALLS
They are endorsed by the best dairymen, approved by representatives of the U. S. Bureau of Animal Husbandry. Guaranteed to meet your approval. Latest improvements place them more than ever beyond comparison with any other equipment. If you are thinking of improvements in your barn, you will save money by getting prices and descriptive matter of James Sanitary Stalls and Stanchions, Feed Carriers and Litter Carriers.
W. D. James, Mgr., KENT MANUFACTURING CO.
160 Cane St., Ft. Atkinson, Wis.

SAVE YOUR HARNESS

BY THE USE OF
FRANK MILLER'S HARNESS SOAP HARNESS OIL HARNESS DRESSING

Occasionally a dealer may try to substitute something on which his profit is larger, but the majority will recommend the old reliable Frank Miller's "BLACK BEAUTY"

We want you to have a copy of this wonderfully interesting book, the "Uncle Tom's Cabin" of the horse. Probably no book has ever received such universal and unanimous praise from both the secular and religious press.
Write us to-day, mentioning this paper, and enclose 6 cents in postage, to cover mailing expenses, and we'll promptly mail you a copy of "BLACK BEAUTY," 200 pages, colored covers. Don't delay. Supply limited.

THE FRANK MILLER CO.
ESTABLISHED 1836
349-351 West 26th St., New York City

Live Stock and Dairy

How to Bar Out the Dirt

ONE prime requisite in making good butter on the farm is a clean sanitary milk for the starting-point. If milk has once become tainted or bad flavored, the effects of it cannot be overcome, however careful one may be in after treatment of the butter.

In order to produce a clean milk it is necessary to have as clean producing conditions as possible.

This does not mean that the cow must be given a bath before each milking, but that reasonable cleanliness must be maintained. The cow naturally is a clean animal and will keep herself quite clean. But one should see that the milk-pails and other tinware are cleaned daily, that the milker is not dirty with his milking and that the stable is as free from dirt, dust and cobwebs as possible.

The most thorough way to clean tinware is to first wash in a liberal amount of lukewarm water containing some good washing soda, using clean, firm rags, then scald all the parts in boiling water and leave them exposed in the sun until ready for use. Care must be taken to wash out all crevices in the tinware, where the bails are fastened to the pails and wherever milk or dirt can find a lodging-place.

The milker should keep himself clean, and it is a wise plan to have a regular milking suit which may be hung in the barn from one milking to another. An overjacket and a pair of overalls answer the purpose fairly well.

The stable should be kept as clean as is practicable. A coat of whitewash on the ceiling and walls helps wonderfully. Whitewash lightens a stable, makes it sweeter, purer and is a good disinfectant. It can be put on some rainy day and it costs practically nothing. Overhanging cobwebs are not only unsightly, but actual holders of contamination. It is hard to keep the stable entirely free from webs, but a good coat of whitewash will largely solve the difficulty.

All odors should be reduced as much as possible, because milk very readily absorbs these and imparts them to the butter. Good ventilation is essential and the manure-pile ought to be a safe distance from the milking quarters. It is better to haul it direct from the stable to the field where it is to be spread, especially during the summer months when fermentation is more active. The floor should be of concrete or very good under drainage established. Oftentimes when the floor is not very tight, the liquid manure will seep down through the cracks and collect under the floor.

When the cow comes from the pasture she is generally reasonably clean; but in the stable, being held in the stanchion, she cannot keep herself as clean as she does when at liberty, and the milker should try to get her as free from dirt as she would naturally keep herself. In some dairies the practice is made of washing the udders and flanks before each milking and stretching a chain under the cows to prevent their lying down; but this precaution, though desirable, is hardly practical on the farm where no extra fancy price is received for the product. If the milker brushes off the udder and hind quarters very carefully and milks with clean, dry hands into a clean pail, there is little harmful contamination. The milking should be done quickly, but thoroughly, and the pail held between the knees rather than set on the floor, where the cow is more liable to get her foot in the pail or kick dirt into it.

Ordinary tin milk-pails are most generally used in the stable. What are known as the Gurler sanitary milk-pails are preferable and as cheap in the end, as they are built stronger and will last longer than the ordinary milk-pail. The pail has about the capacity of others, but the top is partly covered, leaving a small



The Gurler Pail

circular opening where the milk enters. The cover device holds a strainer consisting of absorbent cotton between sheets of gauze. This keeps all loose dirt out of the milk and is very little more trouble than the ordinary kind. The milk should be strained soon after being drawn and not allowed to set unstrained until time for separating. A desirable way of straining is to use a quart can for storage-room and procure a regular strainer for this can, into which the milk from each cow is poured. It needs no further straining before being separated.

Extreme care should be exercised in handling the milk if there is any contagious disease, such as typhoid fever, on the farm. The person who milks or takes care of the apparatus should not take care of the sick. If absolutely necessary to combine nursing and dairy duties, separate clothes should be had for each work and the hands washed in a solution of creolin or other disinfectant. The pails and tinware should be sterilized very thoroughly and no chances taken.
LYNFORD J. HAYNES.

Another Sanitary Pail

WITH all the improvement of dairy conditions late years I have seen comparatively few dairymen using a strainer top to protect the pail during milking. From my experience I not only advise it, but would, if I could, make it an obligation to use them throughout the land, except, of course, where milking-machines were used. Though one may have given the best of attention to

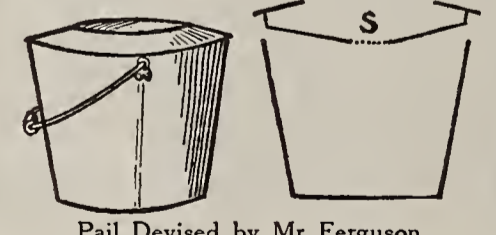

Pail Devised by Mr. Ferguson

cleanliness before milking, a strainer that fits and covers the pail will collect a quantity of hair and dust, with other matter that one can hardly tell the origin of, that will surprise the best of us. All the filth thus kept out would scarcely be observed if milking into an open pail.

The accompanying diagram shows a protecting cover which I have for my own use. The rim surrounding the hole in the center of the top decreases the area of the opening of the pail and keeps out some dirt without discommoding milking. All the milk passes through the strainer (S) which is made of fine brass wire. This top can be made by any ordinary tinsmith to fit into the size of pail used, and it is easily cleaned. The milk gets a second straining at the house.
E. L. FERGUSON.

Farm and Fireside, June 25, 1910

ON THE BEAUTIFUL ST. JOHNS RIVER

about midway between Jacksonville and the St. Cloud Old Soldier Colony, in one of the health resorts of Florida where 1500 northern tourists spend every winter, in a nice little town we have 8 3/4 acre lot, all fenced in with best chicken wire fence. Two story six room well built house with wide two story porch. Three acres set out in grapes. Owner made 40 barrels of wine two years ago. Wine cellar 14x14, two barns, chicken houses 4x6 for brooding; 4 cross fences; 36 pecan trees, 7 pear, 6 plum. Would make an ideal fig or grape fruit farm. It is 3/4 mile from the steam boat landing, and 3 miles from railroad depot. Well settled community. \$1900.00, or will exchange for income property north of the same value.

Also, right in town, two story eight room house with wide veranda two-thirds around house. Barn 16x18 with shed. Wine house. Six acre lot, all fenced in with ten strand wire fence. In the front yard, one beautiful magnolia tree, one holly, one palmetto and one crape myrtle. Best well of water in the town. Pears, grapes, plums, etc. Here is where roses bloom the year around, and every kind of vegetable grown with but little labor. Year around climate, with river and ocean breezes. Fine fishing and hunting. Price \$2000.00. Part cash, balance on time, or will take good northern property same value. Perfect title. Send for photos of these places

W. M. SCOTT & CO.

210-212 Gould Bldg. Atlanta, Ga.

A Handsome Flag For the Fourth of July



CELEBRATE the glorious Fourth with a big, handsome, new flag. FARM AND FIRESIDE has obtained a small supply of large American flags made of the best cloth, and you can have one, without cost, if you act at once.

This beautiful flag is 4 feet long and 2 1/2 feet wide. It is guaranteed fast colors. The red and white stripes are 2 3/4 inches wide and each star is two inches wide. It has a white tape edge with brass eyelets set into the corners, for fastening to a rope on a flag pole.

How to Get the Flag

We will send you this American Flag without cost to you if you will send us only three 8-month subscriptions to FARM AND FIRESIDE at 25 cents each. Your own can be one. Send us the three subscriptions and you will have the flag by return mail. Address

FARM AND FIRESIDE
Springfield, Ohio

Boys! Read This Offer

A FINE FIELDER'S GLOVE, well made and durable and of latest design. This glove is substantially fashioned and is all ready for use. Requires no breaking in and is well padded.

A STRONG MASK, made of heavy, bright steel wire, well padded and finished in the approved manner. An excellent protection to the face.

A CATCHER'S MITT of the latest model, well padded and serviceable. It is the same in design as those used in the big leagues and will wear well.

THE OFFICIAL BASE-BALL GUIDE. This guide is brimful of base-ball information. All the rules, records and pictures of the best known players. Everything that you want to know about base-ball.

A Gift To You

For full particulars, explaining how you can secure any or all of these fine Base-ball supplies, write at once to

FARM AND FIRESIDE
Springfield, Ohio

Live Stock and Dairy

Safety After Calving

SEVERAL dairymen have written for information on the management of their cows at the time of freshening. Methods for preparing the cow for freshening were discussed in the April 25th issue of this paper, under the title: "Safe Calving."

The cow that has been given the preparatory feeding there described does perhaps need closer attention at calving-time, for she will be in better flesh, and the fleshy cow is, of course, more liable to milk fever than her thinner sister. If proper precautions are taken, however, no great danger from milk fever is to be apprehended.

During the St. Louis Exposition, out of the twenty-five cows on test, from thirteen to fifteen had milk fever slightly. During the first two nights an attendant was always on hand, and every hour or so a wisp of hay was offered each cow; if she declined this or her eye began to look dull, there were symptoms enough to indicate that perhaps milk fever might be coming on, and the usual treatment, injection of air into the udder, was applied. Within thirty minutes the cow would be in her natural condition and as a rule no further trouble would occur. In case she had a relapse, the treatment was again applied. There is no risk in the treatment if the air tube is kept well disinfected.

A good ration to start with is about four or five pounds of the same mixture as was fed the cow prior to freshening. Two or three days after freshening, the cow should be put on a small grain ration in conjunction with her corn-silage and alfalfa or clover hay. Now, the purpose is to gradually transfer the fat from her body to the pail. This is accomplished by the use of a small nitrogenous ration. If a heavy ration rich in carbohydrates is given, the cow will be further encouraged to lay fat on her body and will not respond at the pail.

Weigh the milk produced on a four-pound ration and the following day increase your ration one half pound. The following day again weigh the milk. If there has been a sufficient increase to pay for the food and a profit thereon, give her an additional half-pound and thus continue raising the ration half a pound every other day, and on the days when the ration is not raised note the amount of milk given. If she is a good cow and yet does not continue to respond to increase in ration up to twelve or fifteen pounds of grain, then perhaps something is wrong with the kind of ration.

Whenever a cow gives indication of becoming too fat, then a portion of the fattening foods should be withdrawn and its place filled with foods rich in protein, the milk stimulating part of the feed. On the other hand, if a cow begins to become poor, care must be taken not to feed too heavily of protein, allowing more of the fattening foods.

After the cow is on full feed, care must be exercised at all times not to overdo her or sicken her by feeding too heavily. So long as she cleans up her feed with avidity, the digestive apparatus remains in good order and she is apparently lively and thrifty, there is little danger of feeding her too heavily, especially if cut-hay be combined with the feed at the rate of two pounds at each feeding.

If the feed is thus carefully raised, the cow will be stimulated to produce the very greatest amount of milk that lies within her possibility; while if the feed were raised by large amounts at a time, there would be no greater increase from the large amount of feed than from the small amount.

In fact, many dairymen really injure their animals by stuffing them. Feeders of beef cattle realize that when strong, thrifty steers are placed in the feed-lot, they must be placed on feed gradually and take from four to six weeks to get to the point where they are consuming all the feed they possibly can. These same feeders when placing a small dairy cow, delicate from parturition, on feed, forget this important fact and expect her to handle amounts of feed that even a large, strong steer could not handle.

As for the other general care—milk-ing, etc.—it goes without saying that a cow should have warm, dry quarters, a well-bedded stall, be kept out of the cold in the winter-time, given plenty of fresh air and sunshine and warm water to drink. In the summer-time she should be sheltered from the heat of the sun, the hot winds and flies, and given every opportunity possible to do her best work.

HUGH G. VAN PELT.

An Iowan's Cattle Wisdom

JAMES HOBBS, of Woodbury County, Iowa, is a sturdy son of Albion, with the characteristic hard-headedness of the Englishmen. He came to western Iowa in an early day and braved the privations of pioneering. He has grown rich with the development of the country, owns a section of highly-tilled land, a comfortable modern home and enjoys a fine family of children. He ascribes his financial success mainly to the profits made from feeding cattle for the market. He has had thirty years of experience in the business, and has reason to feel that he has learned a good many things about it worth knowing.

In a recent conversation, Mr. Hobbs described some of his methods as follows:

"I began feeding for the market in a small way. At first I fattened only the stock raised upon my own farm. Then I began to reach out and get hold of more cattle to feed, in order to consume all the stuff raised upon the farm. I soon learned that it is poor business policy to sell feed-stuff off the place.

"I have never used condition powders or specially-prepared stock-foods. Many successful feeders use them, but I have never seen the need for them in my business.

"I use self-feeders. Feeding in the troughs twice a day is monotonous and tiresome. I believe in making the work the farm boys are required to do as pleasant and as light as possible. In the winter-time we never do any work on my farm before eight o'clock in the morning, nor after five o'clock in the evening. My boys have never shown any disposition to get tired of farm life, nor have they expressed any longings for the attractions of the city.

"The most profitable time to feed cattle is July, August and September, when they still have grass to run on. But I never think only of the profit in feeding cattle. It is such a delight to watch the steers eat and grow, the very joy of it is worth lots of money. On summer days I often take my farm papers, a whole roll of them, and go to the feed-yards, find a nice shady place and spend hours reading and enjoying myself among the cattle.

"I never feed fancy steers for the top of the market. I stick to the average kind. To produce fancy beef requires too much outlay in the first cost and too high a degree of rather technical knowledge for the ordinary farmer to undertake it. "It is entirely a wrong policy to sell the feed-stuff from the farm. Every farmer should sell his grain and hay through some sort of profitable stock. It saves the cost and labor of taking it to the railroad, which is no small item. It is no great task to take several thousand bushels of corn to market after it has been fed to steers, and the fertilizing by-product of feeding is one of the greatest gains derived.

"I used an eighty-acre lot for feeding for five consecutive years. Last season I cultivated it to corn, and made one hundred and fifteen bushels to the acre. The average yield for Iowa was but thirty bushels to the acre. Land that will produce a hundred bushels of corn is worth two hundred dollars an acre. Land that will only produce thirty bushels is not worth over fifty dollars an acre."

M. G. RAMBO.

Boiled-Down Pointers

A little bit of meal in the manger at milking-time is a time-saver. The cows come more quietly if they expect that meal than they would if a dog were tight to their heels, they give more milk and better milk and they will keep in better flesh.

If you want to know how essential pure, cool water is to profitable swine-raising, feed a hog on a moderate amount of swill and milk just ten hours; then offer it some fresh, cool water by the side of any other kind of rations you can rake up and see how quickly and greedily he will choose the simple water.

Every day as long as they will come for it plan to feed the lambs some grain. A good way to be sure they will get it, and not the old sheep, is to have a little inclosure just off the sheep pasture, with a small opening between, so that the little fellows can crawl through and get their rations without being disturbed. But close that opening when you are not nearby to attend to things, lest some sheep try to wedge herself through and get caught.

Not the Cow's Fault

A READER in Charleston, Missouri, writes: "I have a Jersey cow, young, with-in four months of third calf. Up until now her milk was sweet and good. Now the milk, often turning, has a cheesy taste and butter cannot be used. Cow seems hearty. Food is alfalfa and corn and bran in moderate amounts."

It is difficult to know what can be wrong with your cow's milk and it is even more difficult to believe that it is in any way the fault of the cow or her feed. There is nothing in alfalfa, corn or bran that would cause the milk and butter to be of the character which you state.

The amount of feed the cow should be receiving is one pound of a grain mixture to every three pounds of milk she gives daily or a pound daily of feed for every pound of butter the cow makes in a week.

It is more reasonable to believe that some germ is causing the trouble with the milk and butter. Oftentimes such germs become prevalent in the barn or where the milk and milking utensils are kept or in the separator, and then it is absolutely impossible to change the character of the milk until these things have been rectified.

I would suggest as the first thing that you thoroughly disinfect your barns, allowing the sunshine to come into them. Thoroughly wash the udder and teats and flanks of the cow before milking, and boil thoroughly all milking utensils and your separator, leaving them out in the sunshine during the day so they will become free from any germs that may be present. Then when the milk is drawn, cool it down immediately by surrounding the vessel containing the milk with cold water and stir the milk to take out all animal heat and odors. The milk should then be set away in a perfectly clean place where it will not become contaminated with odors or infected with germs later.

With this care, undoubtedly the milk will at once become good again and then, of course, there will be no trouble with the butter.

H. G. V. P.

I have been a reader of FARM AND FIRESIDE for a number of years and like your paper very much.—H. C. Kemever, Jeanette, Pennsylvania.

After "Sousters"



A pan full of disks the maker says "souse as one piece."

"Soustering" or rinsing complicated cream separators is both unsatisfactory and unlawful, for laws are being passed to stop it.

Here is the South Dakota law:

"Cream shall be unmerchantable for buttermaking if it has been skimmed by a filthy, unclean, unsanitary or unwashed separator."

Other states are passing similar laws. Makers or agents who advise "soustering" are willing to make a law breaker of you, to cause you the loss of your cream, or make you liable to fine or imprisonment, in order to sell you a complicated machine. Wise dairymen let disk-filled and other complicated machines alone. They prefer simple, sanitary, easy to clean

Sharples Dairy Tubular Cream Separators

for Dairy Tubulars have neither disks nor other contraptions, yet produce twice the skimming force of common separators. The World's Best. World's biggest separator works. Branch factories in Canada and Germany. Sales exceed most, if not all, others combined. Probably replace more common separators than any one maker of such machines sells. Write for Catalogue 112.

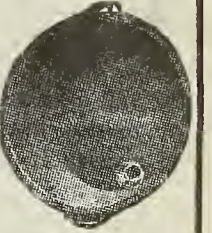

The only piece inside Dairy Tubular Bowls.

THE SHARPLES SEPARATOR CO.
WEST CHESTER, PA.
Chicago, Ill., San Francisco, Cal., Portland, Ore.
Toronto, Can., Winnipeg, Can.

POST-CARDS WITHOUT COST

We will send you the complete set of the famous 24 Roosevelt in Africa post-cards if you will send us 10 cents each for two three-month trial subscriptions to FARM AND FIRESIDE. The two trial subscriptions must be new subscriptions. Remit in coin or stamps.

FARM AND FIRESIDE
Springfield, Ohio

BREEZE 7 Handsome Models \$275

Travel the worst roads with ease and comfort And Up SEND FOR CATALOG "U"



The Breeze is strong, simple, speedy and safe. Best motor vehicle built for country roads—mud, deep sand or high hills. 13-18 H.P. engines. Lowest cost of upkeep, least tire trouble! Handsomely finished. THE JEWEL CARRIAGE CO. CINCINNATI, OHIO



Fire Prevention Lowers Your Insurance

THE fire loss in this country, last year, was \$1000.00 per minute! Analysis of this appalling loss shows that much of this damage was caused by hot sparks and cinders which fell on adjacent roofs from local fires—or from locomotives.

REX FLINTKOTE ROOFING

will protect your buildings from fire. Its substance, its chemical treatment and its surface are such pronounced fire retardants that Boards of Fire Underwriters endorse it. Use Rex Flintkote Roofing and lower your Insurance! It has proven its fire-resisting qualities hundreds of times. Send for our large, new book, "Roof Fires." Send to-day; it's free.



FOUNDED 1837

J. A. & W. BIRD & CO.
24 India St., Boston, Mass.

AGENTS EVERYWHERE

SUBSCRIPTION PRICE

One Year (24 numbers) 50 cents
Canadian Subscriptions . 1 Year, 75 cents

Entered at the Post-Office at Springfield,
Ohio, as Second-Class Mail Matter.

Subscriptions and all editorial letters should be sent to the offices at Springfield, Ohio, and letters for the Editor should be marked "Editor."

The date on the address label shows the time to which each subscriber has paid.

Subscribers receive this paper twice a month, which is twice as often as most other National farm journals are issued.

Silver, when sent through the mails, should be carefully wrapped in cloth or strong paper, so as not to wear a hole through the envelope.

When renewing your subscription, please say it is a renewal, and if possible send the label from a recent copy. If all our subscribers will do this a great deal of trouble will be avoided.



PUBLISHED BY
THE CROWELL PUBLISHING COMPANY

SPRINGFIELD, OHIO

Branch Offices: 11 East 24th Street, New York City

Tribune Building, Chicago, Illinois

Copyright, 1910, by The Crowell Publishing Company

ABOUT ADVERTISING

FARM AND FIRESIDE does not print advertisements generally known as "readers" in its editorial or news columns.

Mention FARM AND FIRESIDE when you write to our advertisers, and we guarantee you fair and square treatment.

Of course we do not undertake to adjust petty differences between subscribers and honest advertisers, but if any advertiser in this paper should defraud a subscriber, we stand ready to make good the loss incurred, provided we are notified within thirty days after the transaction.

FARM AND FIRESIDE is published on the 10th and 25th of each month. Copy for advertisements should be received twenty-five days in advance of publication date. \$2.00 per agate line for both editions; \$1.00 per agate line for the eastern or western edition singly. Eight words to the line, fourteen lines to the inch. Width of columns 2 1/4 inches, length of columns two hundred lines. 5% discount for cash with order. Three lines is smallest space accepted.

Letters regarding advertising should be sent to the New York address.

The Railway Situation

WHY did the railways order a general advance in rates in the spring and summer of 1910?

The answer lies right out in the sunlight. It is this. The prospects seem to be that Congress will pass this session laws giving the Interstate Commerce Commission greater power to hold back rate advances and making it necessary for the railways to show that advances are reasonable rather than for the people to show them unreasonable, and the railways rushed their advances through so as to get ahead of the change in the law, and thus checkmate the government.

It seems impossible that the railway managements could have expected President Taft to sit still and allow the administration to be headed off in this transparent way, and yet, when the attorney-general went into court and asked for injunctions against the move, there was excitement in Wall Street, and prices of railway securities fell off.

If the government action were to be construed as an attack on the right of the railways to earn fair returns on their investments, we might well take the railway side in the matter; but there is not the slightest reason for calling it any such thing. The prices of stocks are always balanced between the pressure of the bulls and the bears on opposite sides of the market, and any occurrence whatever which can be used as a lever is always utilized by selfish interests to topple the unstable thing over one way or the other. When the bears heard of the action of the government in blocking the railways' game, they ordered out the heavy brigade and charged. Prices went off under the impact. That is about all there is of it. Real values in railway securities remain unaffected.

We may be assured of the fact that the railways are not severely affected by the situation by comparing the utterances of the railway representatives themselves. James J. Hill of the Great Northern system said that the excitement in Wall Street was mostly manufactured and that he didn't think it was going to be much of a shower. He added that the real problem of the railways is to take care of the business which they will have to carry, thus supporting the statements made in these columns recently. President Ripley of the Santa Fé said, after the compromise with the administration was agreed to, by which all the railways, east and west, undertook to delay advances until the new law can take effect, that the conference with the President has not cleared matters up and that the railways cannot undertake improvements unless they are allowed, not only to make the advances already filed, but "much larger increases." Of more than twenty railway men and financiers interviewed in New York right after the compromise with the administration, all but one expressed themselves pleased with the manner in which the situation had been handled by the President.

In the meantime, the shippers' organizations feel that they have gained a great victory in having the rate advances halted until Congress can take action.

It is well to bear in mind the fact that the interests of farmers are not identical with those of shippers. Most of the things we sell are priced with reference to world's markets, and the increases in freights will come out of our incomes to the last cent, while most of the things we buy are priced at the factory with freight added, and we have to stand every bit of these advances, too. The farmer will be whipsawed whether rates are advanced evenly all over the nation or not. Shippers, on the other hand, are very little concerned with advances unless their competitors are given more favorable terms. With farmers, all advances are important, whether discriminatory or not. Farmers and consumers generally cannot afford to lie supine, thinking that the shippers are making their fight for them. Farmers' organizations should study the situation and make their influence felt for the cause of justice, aiding the shippers where their interests are identical with ours and making our own contest along our own lines when necessary.

All any of us should ask is justice, and the railway managements should be willing to concede that. It is a time for vigilance, for intelligent study and for vigorous action. Our prosperity for a generation may depend upon the events of the next year or so.

The price of pig
Is something big
Because its corn, you'll understand,
Is high-priced, too;
Because it grew
Upon the high-priced farming land.
If you'd know why
That land is high,
Consider this: Its price is big
Because it pays
Thereon to raise
The costly corn and high-priced pig!
—Smith County News, Tennessee.

Government Whitewash

THE formula for government whitewash is as follows: Slake one half bushel of quicklime with boiling water. Cover it as soon as the water is applied. When slaked, strain it and add a peck of salt. Then dissolve three pounds of ground rice in warm water, having previously boiled the rice to a thin paste. Put in half a pound of Spanish whiting. Dissolve in warm water a pound of clean glue and put that in. Mix the whole well together, cover it up and let it stand for several days. When wished for use, reheat and apply hot. Apply it to the inside of stables, basements, kennels, poultry-houses and to the outside of buildings which you do not desire to paint. It will resist the action of the weather for several months.

Yes, that's all. It is claimed to be the best whitewash known and is called government whitewash because it has been used by the United States Government about barracks, forts and the like where a good whitewash is required and paint is not demanded.

No! There isn't a thing in about Ballinger!

Cut it out! Put it in your recipe-book. It will be useful after Ballinger is forgotten.

* * *

The way to better farming is the way of better thinking.

The very worst form of pessimism is implicit faith in other pessimists.

Lots of boys leave the farm "'cause dad's too cross, and nothin' don't never please him that I do."

The difference between the man who has made a success in life and the man who has made a failure is simple—the latter made, perhaps, but one failure, while the other has made a dozen or more failures, but wouldn't stay failed.

By writing to the Family Butter Merger Company, of Brooklyn, New York, you can obtain a wonderful "new discovery" by the use of which you can take a pint of milk worth four cents and a pound of butter worth thirty cents, and "merge" them into two pounds of first-class butter, which is advertised to "look just the same" as creamery butter! Fine scheme! We cite an advertisement of this great "discovery" in the Kansas City Journal. It is of interest as showing the sort of advertisements that some papers will take. Also the sort of bait that some sorts of fish will bite at.

Paper From Corn-Stalks?

THE United States Department of Agriculture has been studying the possibilities of making paper from corn-stalks. It has had an experimental plant in operation near Portland, Maine, for some time, and now announces through the press that corn-stalks offer a material for making the high-grade book and stationery papers that rival wood pulp in cheapness. The amount of vegetable fiber wasted in the corn-stalks plowed down every year in the corn belt is enormous, and any plan which would utilize it is of immense interest to farmers everywhere. Let us hope that this will not prove a disappointment like the denatured alcohol fizzle. And if we do find a way to market our corn-stalks, we must bear in mind that we shall have to devise plans for supplying the increased drain on the soil in plant-food and humus. Everything in this world has to be paid for. Something for nothing never comes to the farmer, however it may be with some others.

What Keeps Down Water Competition?

RAILWAY freight rates between eastern and western ports on the Great Lakes are being steadily advanced. On cement, the rates between Erie, Pennsylvania, and Duluth and Chicago and other points, including Cleveland, Joliet, Detroit and St. Louis, have been increased, according to press despatches from Washington, by from sixteen per cent. to thirty-one per cent.

This follows the completion of railway control of the Chicago wharves and docks, coupled with similar domination of the water fronts of all the rest of the lake cities.

Waterways are of no value as regulators of rail rates in the absence of free and publicly controlled docks and wharves, for the reason that every trip by water begins and ends at the shore. He who controls the shore controls the water.

It is announced that lumber rates from Pacific Coast points will go up next fall. This means dearer buildings. If the Panama Canal were completed and made free of tolls, no such rates could be advanced. In fact, they would have to fall.

We want a free Panama Canal, improved waterways and, above all, free publicly owned wharves and docks. Unless we have these, our freight situation will grow steadily worse.

* * *

One thing to make the farm-wife happy—she doesn't have to use cold-storage eggs.

"Back to the land" is a good slogan, but it has little application to those who have never been on the land.

The good farm-land in the United States may be about all taken up, but the best methods of farming it are just beginning to be discovered.

The rat question is one of the most serious the farmers have to deal with. And yet it is one that we are apt to slip over, because we think rats are a necessary pest. It is a mistake. Every farmer can clear out the rats on his place if he really sets out about it. Traps, cats, ferrets will do it—with a good, live man behind them to direct their operations.

OUT OF THE LETTER-BOX

EDITOR FARM AND FIRESIDE:—

Your editorial of April 25th, "The Rural Schools on Trial," was on just the subject I had been wanting some one to talk about. The schools of to-day are not in reality schools for education. The schools here in Indiana seem to scorn the spelling-book. The new pupils are not taught to spell a word and pronounce that word, but, instead, are taught to read (as we sometimes call it) by heart. They learn nothing of vowels, consonants, articulation or the art of spelling or pronunciation.

Then there is arithmetic. They will never get an arithmetic that will make two times two more than four. So what is the use of making different rules that make simple problems like that into perplexing ones? For example, I have a girl going to country school here in what is now called the "sixth year." I asked her one day as a test, "If I buy fish for eight and one third cents a pound, how many pounds of fish will I get for fifty cents?" Well, the girl could not solve that problem because it was not in the book.

Is this the kind of education we want our boys and girls to have? Give us more articles on the reformation of the common schools until we can get the proper authorities to act and get back to a kind of schooling that is practical.

Indiana.

ULYSSES HOGGATT.

That's right! We believe the rural schools ought to teach something more than the three R's—but before they attempt anything else they ought to teach the three R's in the right way. Do any of our readers live in communities that have solved this difficulty? We should be glad to hear how the reform was brought about. What did you do about it? EDITOR.



The FARMERS' LOBBY.

By Judson C. Welliver

INSURGENCY has just naturally been licked out of its boots in Congress this session. If you don't believe it, ask anybody who knows that insurgency is a bad business that ought to be suppressed.

The insurgents used to call themselves progressives, but latterly they have rather leaned to the title of "insurgents." One of them told me the other day why he felt that way about it.

"Don't call us 'progressives,'" he said. "I prefer to be designated as an insurgent. I've been looking into the articles of war, and find that an insurgent, if he continues such for a long enough time, ultimately secures belligerent rights. Now, an insurgent is liable to be seized and hanged for treason; but if he sticks to his insurgency long enough, and manages to avoid capture and hanging, he presently establishes the status of a belligerent. That seems to mean that he has a right to fight, and, having the right, he can be licked if the other side is strong enough to lick him; but he can't be hanged without a violation of the proprieties.

"As things stand now, we are insurgents, but I don't understand that we have secured belligerent rights. We are being read out of the party from time to time, which is the political method of hanging us. It happens that we haven't accepted the verdict and have appealed to the people. The reports we get from home convince us pretty thoroughly that the sentence will not be executed."

I think it was Bill Nye who told a story which illustrates how the insurgents have been trounced this session. If it wasn't Bill, then apologies are duly tendered to both Bill and the man who really did invent the story.

Something Like the Regular Victory

"Yes, siree," declared the battered-up man who was sitting on the dry-goods box at the corner of the public square in Squeedunk, "it was a great fight we had. He come at me hammer an' tongs, an' I see right away that I'd have to beat 'im by strategy. An' I done it, too. When he made his first lunge at me, I stuck out my face at him an' he almost broke his fist on my nose. Say, he must have a mighty sore hand for that p'formance. That was the first blood I drew; it come out o' my nose.

"Then we grabbed hold of each other, an' I see to oncet that he hadn't got enough. So I got down on my back on the ground an' pulled him over on top o' me. I worked my stomach around under his knee and made 'im put his arms around my neck. Then I firmly inserted my right ear into his mouth an' forced him to chew the lower half of it off. Can't show you how well it worked, 'cause the doctor has tied it up in this here bandage; but I tell you it was the greatest piece of strategy you ever see. While he was chewin' away at that ear, I distracted his notice yellin' for help; an' he fell right into the trap. He hauled off an' hit me in the mouth, knockin' out them two teeth that you don't see where they us' to be. Well, sir, he hit me so hard that his arm was a'most paralyzed an' his fist must a-been skinned all up on them teeth. To make it more humiliatin' for him, I swallered the teeth.

"Seein' that I had 'im goin' fast, I made a desprit lunge at 'im with my head, catchin' his left fist with my right eye. Say, it must have broke ev'ry bone in his paw, fer my eye swelled shut right away, an' when he tried to do it again—didn't have no more sense than to want to do it over an' hurt his fist some more—the eye was closed an' he couldn't see where to hit it! That was ruther the finest piece of tactics I worked off on 'im. Wisht I c'd show ye the eye, but it's had this here rag around it ever since; you'd see how fine I played it on him if you c'd notice that optic."

Well, translated into terms or parliamentary procedure, that would be a very good account of how the regulars have thrashed the insurgents this session. It has been a scandalous slaughter. Nothing like it has been seen since the Russians licked the Japs in the press reports of the war in Manchuria.

At times it has been positively cruel, the way these regulars of the Aldrich-Hale-Cannon persuasion have pommelled the insurgents. By the way, the safe-and-sane newspapers have been referring to them of late as "rebels", which is understood to be even more opprobrious than "insurgents." Uncle Joe Cannon, speaking at a New York banquet, actually declared that every one of 'em ought to be hanged, which would seem

to indicate clearly that Uncle Joe hasn't decided yet to confer belligerent rights on them. He is out to pulverize the rebels, and he will succeed, from all present indications—including the accepted forecasts of Democratic victory next fall. Uncle Joe and his friends expect that the House will be Democratic next Congress, and they are already pointing to that result as a victory for regularity with as much pride as our belligerent friend with the bandaged head did to his mutilated left ear.

Honors are about even, thus far, between Uncle Joe and Attorney-General Wickersham in the matter of paralyzing the rebels. Mr. Wickersham has an amiable way of making a speech every now and then and "reading out of the party" everybody who has assumed to doubt that Mr. Wickersham's hand-me-down railroad regulation bill was the real, progressive, Roosevelt-policy scheme for getting the head of the railroad octopus into chancery where it could be hammered at leisure. Mr. Wickersham has known all along just what ought to be done to the railroads. He has been perfectly vicious about it. He learned the art during his long service as attorney for the Wall Street men who run the railroads. It is a perfect shame, how so many people refuse to take seriously Mr. Wickersham's plan of regulating the railroads. They don't understand that Mr. Wickersham believes in the ancient strategy of "jine 'em to bust 'em." He "jined" the Wall Street forces many years ago, in order to be in shape to bust 'em as soon as he had got all the inside information and should be ready to assume the duties of attorney-general. Mr. Wickersham spent some thirty years as a lawyer for big business interests, learning the secrets of the wicked trusts, in order that when he became attorney-general he might be in shape to give 'em the very sort of medicine they needed. The "rebels" say he gave it to 'em, too, just the kind they wanted, and that the dose would have been entirely to their liking if insurgency hadn't compelled the addition of some new and utterly unexpected ingredients to the dose.

The Forest Service Insurgency

The way "insurgency" has been crumpled up and pitched out of the window from time to time has been one of the wonders of the last few months. Pinchot was ill-natured enough to allege that Secretary Ballinger was not running his job right; ergo, Pinchot gets fired; and—ergo once more—Pinchot is thereby proved to be a malicious prevaricator, and Ballinger a good, though maligned, citizen!

Glavis presents a case to President Taft in support of the accusations of Pinchot. Ergo, Glavis is fired; and—still another ergo—Glavis is shown up as a dangerous party!

Attorney Brandeis, representing Glavis, alleges before the investigating committee that President Taft's exoneration of Ballinger was written by the subordinates of Secretary Ballinger. Mr. Ballinger and everybody else deny knowledge of such a proceeding. Then Stenographer Kerby comes along with his little shorthand note-book and a circumstantial narrative, and proves that Brandeis was right. That might look like a pretty bad situation; but it wasn't.

Kerby is promptly shot into outer darkness, detached from his job, denounced as faithless and the supporters of Mr. Ballinger write able editorials showing how reprehensible it is for a man in Kerby's position to violate the confidence of his employment! Kerby is found to be a malevolent cuss who really couldn't be admitted to the best circles, and everybody is delicately requested to take careful note of his shortcomings and forget what he said about Ballinger and the genesis of the Taft exoneration!

The stenographer's note-book is getting, by the way, to be one of the most grave menaces to our institutions. It was another indignant stenographer, if memory serves aright, that read out of his fish-hook and comet-tail hieroglyphics the exact text of those Harriman letters which brought before the public the tale of how the railroad magnate raised a one-hundred-and-fifty-thousand-dollar campaign fund in the closing days of the 1904 campaign, at the urgent solicitation of President Roosevelt. That ought to have been ample warning of the necessity to pass legislation suppressing all stenographers' note-books; and certainly the Kerby incident reinforces the suggestion that legislation against the conservation of

note-books is one of the crying needs of the times.

But I was talking about the outrageous fashion in which the insurgents have been defeated from time to time by the regulars during this session, and that takes me back to the railroad legislation. The way the regulars have been winning tremendous parliamentary battles is something like this:

"I move," says Senator Aldrich, "that a hundred be declared to be composed of ten times five."

"I amend," interjects Senator Cummins, "that a hundred be declared to be composed of ten times ten."

Whereupon they talk for five days. At the end of the fifth day Senator Aldrich announces that the regulars have the votes necessary to maintain their position that ten times five equals one hundred.

Accordingly on the opening of the sixth day's session a lieutenant of Senator Aldrich rises solemnly and remarks:

"The Senate has now debated this matter for five days. Senators will all agree with me that in no legislative body in the world could such a subject have been discussed with such learning, luminosity and elaboration. Nowhere in history is there record of a legislature in which so many words could be shed apropos of such an incident. I am convinced that the supply of language is exhausted. On a careful examination of Webster's unabridged dictionary I find that of the 166,783 words therein presented, only twenty-three have been omitted from this discussion, and those twenty-three relate entirely to extraneous subjects. Therefore, Mr. President, I move that it be declared the sense of the Senate that nine times ten, plus nine, plus one, be one hundred."

Great enthusiasm in the press gallery. Bulletins are rushed to all quarters, stating that the organization has won and the rebels are once more overpoweringly defeated.

Senator Cummins rises in his place. "Inasmuch," he says, "as nine times ten, plus nine, plus one, is mathematically equivalent to ten times ten, I renew my motion that ten times ten be declared one hundred."

Instantly, from the galleries and from the regular republican section of the floor, there arises a chorus of, "Abas, abas; down with heterodoxy. Licked again!"

The roll is called; the Senate adopts the declaration that nine times ten, plus nine, plus one, equals one hundred, and the next morning it is notified to the anxious world that the insurgents—the New England papers always say rebels—have been defeated once more.

Facing the Railroad Bill Forward

That is the way the "regulars" have been winning their victories this session. They started out in the railroad legislation to prove that five times ten equals one hundred, and they are ending with the solemn declaration that nine times ten, plus nine, plus one, equals one hundred. But you will understand that it was a "regular," not an evil-minded insurgent, who made the motion that carried. Wherefore the regulars have slaughtered the insurgents!

The truth is that the railroad bill which came into Congress at the beginning of the session had its shoes on backward. It pretended to be going one way, but the tracks it made in the snow showed it was going in the opposite direction. The insurgents took off the shoes, put them on the other way and then made the bill go in the direction that it pretended to be going.

But the regulars, whenever they saw that they were facing defeat, always managed to make a shift in time. They substituted the declaration of "nine times nine, plus nine, plus one" for the declaration of "ten times ten," and saved their face by lining up to vote for it.

The railroad bill will be an insurgent measure with a regular label.

Truly, it has been a hard session for insurgents. They have been utterly unable to accept the invitations that have been pressed upon them to deliver speeches all over the country explaining what they meant and why they were insurgents.

To make matters worse, Messrs. Aldrich and Hale have announced that they will not be candidates for reelection. They are determined to get out and leave the insurgents the responsibility of running the country, confident that that is a sure way to smash insurgency.

Maybe it is. But the insurgents seem willing to assume the responsibility. None of them are resigning, retiring or being licked by their folks at home.

By Grandmother Brittingham's Rule

By Ellen D. Masters

"ACCORDING to Nature and reason, I knew it would happen some time; but, I'll confess, I'm not ready for it." Mrs. Powell shook out her largest parlor rug so vigorously that its rose-covered length undulated like some angry, fiery reptile.

"Law! Celestine, it didn't happen as soon as it might've," remarked Drucilla Crump who had come over to lend neighborly assistance to Mrs. Powell's particular house-cleaning. "Leroy's just the age of my Wesley, and he's been married nine years—past last Christmas. Wait till you've brought up seven and lived to see them all married and doing well, and two of them buried. You don't know anything about trouble, Celestine Powell."

"I don't?" replied Mrs. Powell sharply. "You'd better say I didn't. Yes; I thought the waves and the billows had all gone over my soul; but they hadn't. They never went over till last week, when I went to Leroy's marriage."

Mrs. Crump was applying the whisk-broom to the damask curtains that hung across the garden paling. She paused in her dust-routting efforts and looked up.

"Why, Celestine? Leroy's wife's folks are not stuck up, are they? If Leroy's wife's folks slighted his old mother from the country, I haven't much opinion of them, but they didn't, now did they?"

"No, but I just wish they had slighted me," said Mrs. Powell, giving the rug another shake. "I could see that they were putting themselves out to be nice to me. Everything was flowers and music and laughing and seeming happiness; but there wasn't any happiness there for me. He belongs to them now—to her and her brothers and sisters and father and mother. It broke my heart right out to hear them call him son and brother the way they did. The idea of my Leroy being a son to anybody besides me! And Eulalie, the girl he's married to, what did she ever do for him? Yet he loves her better than he does me."

"Pshaw! Celestine," said Mrs. Crump, bustling about, impelled by a surplus of energy, "you're making yourself sick. You'll be down in bed by the time Leroy and his bride get back from their honey-tower. You go lie down and rest a spell. I'll finish up everything that's to do; I wouldn't give up if I was in your place," she added consolingly.

"I'm much obliged to you, Drucilla. I will stop and lie down a little bit," said Mrs. Powell. "I feel faint."

Drucilla Crump carried the rugs and curtains from the back yard, where they had undergone heroic renovating processes, and reinstated them in the parlor. Although a near neighbor and frequent caller, the parlor was an unfamiliar and mysterious room to her. She had not been in it for years until she came over to help with the particular house-cleaning that Mrs. Powell imagined was necessary to be done before the arrival of her son and his bride. Left to herself, she worked more leisurely and inspected things more closely than she had done when Mrs. Powell was present.

"Just true to life!" she pronounced, pausing to polish and readjust her spectacles in front of the crayon portraits of Leroy Powell and his father that hung above the sofa. "Leroy looks 'most as old as his pa did when he died," she commented, as she studied the face of the son. "I know his age to the day. He was twenty-nine last November—plenty old enough to get married. And I think Celestine is acting plum crazy. The way she's going on, you'd think Leroy had been hung or electrocuted, instead of marrying into a family of good standing. To hear her talk, anybody would think a mother never had a son before—anybody would think there never had been a decent boy around here in forty miles but Leroy Powell. Leroy's nice enough and smart enough—he ought to be. She had but the one, and his pa left her forehanded enough to send him to college and make a lawyer of him."

Mrs. Crump smothered a laugh at her own wit. She liked Mrs. Powell almost better than she liked any one else. For more than thirty years they had run across the orchard to assist each other in times of sickness or weddings or funerals. But perhaps every one of the Crump children had at some time suffered an unfavorable comparison to Leroy Powell, and their mother was merely taking this harmless way of squaring up the overdue account of small grudges that she has charged up against the mother of Leroy.

"I reckon the photograph-takers wish every mother was as doting as Celestine—especially them with large families. It certainly would be a paying business," she commented, as she brushed the plush-bound photograph-album on the center table, and then opened it to take a peep inside. The first half of the bulky volume was filled up with photographs of Leroy, in different attitudes and stages of development.

"I believe if I had been in her place I would have put the likenesses of my old father and mother and my dead husband in the first part of the album."

Mrs. Crump browsed about leisurely, finding food for comment at every turn.

"Well, I never!" she whispered. "Did anybody ever see the like of trash! If she hasn't got every one of Leroy's old playthings strung out over the mantle. In her parlor! Well, if I kept all the gimcracks my young ones ever played with in my best room, there wouldn't be a place for anything else. I'm not going to move all that stuff and dust it," she concluded, "for there's no sense in it being in here." She closed the blinds and shut the door as she went out.

"There, Celestine," she said, in tones of genuine concern, "you'll feel different soon. I'll 'low Leroy's wife never seen a spicker, cleaner house than this one. I'll run over to-morrow noon, before they come up from the depot and help you with the supper. If I was you I wouldn't hurt Leroy's feelings by treating her cool. I expect you'll like her all right; it'll be 'most like having a daughter of your own. I always have said a mother gets more comfort from her daughters, anyhow."

"I don't want any daughter," said Mrs. Powell. "I never wanted any other child but Leroy. He was always so affectionate and thoughtful of me. It'll be



different now—bound to be different. But you needn't be afraid that I'll hurt Leroy's feelings."

Mrs. Crump came back the next day and put wild ferns and pink monthly roses above the dining-room windows and on the table and around the hall stair-rail. And she opened the parlor blinds and let the sunshine stream into the clean darkness.

As unsuspecting and fearless as the stranger sunshine, Leroy's young wife came into the old farmhouse where Leroy had been born and brought up. Leroy had told her, coming up from the station, that he had run barefoot over all the surrounding fields. Almost reverently she crossed the threshold. She came with a loving heart to the new mother—this clear-eyed girl who was living in the land of love. She had thought much and imagined much of this woman. Only something—oh, what was it?—awed her and kept her from saying the things she had planned to say to Leroy's mother. The greeting was quite different from the one she had rehearsed over in her mind.

Only Leroy was boisterous and demonstrative. Catching mother and wife in an all-encircling bear hug, with a laugh and a hand-shake for Mrs. Crump and the few other neighbors who had been invited in to supper, Leroy was the bridge that spanned the chasm. His high spirits offset to advantage the reserved cordiality of his mother.

Drucilla Crump laughed as she went home across the orchard. "Celestine's bearing up well. I never would 'a' believed she'd kiss the girl and make her as welcome as she did. She's just doing it on account of not hurting Leroy's feelings. I've often heard her boast that there was nothing she wouldn't do for Leroy. Well, she's got a chance now to do something for him—something pretty hard for her. And that poor girl's as innocent as a lamb! It's kind o' pitiful the way she looks at Celestine with her big bright eyes, like she was lookin' up to the Virgin Mary. And the way she says 'mother' every time she gets a chance to put it in—of all things!"

It was indeed the hardest thing Leroy's mother had ever done for him—this welcoming of the girl whom she regarded as the thief of her treasure.

"I can't stand it here by myself with her," she said weakly the next day, when Leroy was called unexpectedly back to town by his law partner. This was a calamity, the possibility of which she had never taken into account. The bare thought of being left face to face with the girl, without Leroy to help her over the hard places, almost paralyzed her. "If you must go, take her with you," she said pleadingly to Leroy in secret. "She'll be lonesome here. I'm not much of a talker with strangers. And likely she'd enjoy going back to see her folks."

"No; she wishes to stay with you until I return, mother," said Leroy. He came up and patted her cheeks as he used to do when he was a little boy. "She loves the old farm—and you, mother. Only this morning she said she wished we had come here at first, instead of going to Fairview."

Left alone in the house with her daughter-in-law, Mrs. Powell went about her work just as she was accustomed to, only she hunted up things to keep her occupied out in the kitchen or somewhere. She dreaded being alone with the girl more than anything. There wasn't anything she wanted to say to her but, "You are a thief, a thief—you have stolen him from me." Why should she say anything to her? There was no need now. Leroy was not there to have his feelings hurt. This came as a happy thought.

"Make yourself at home," she conceded. She always said that to strangers when obliged to leave them alone in the house. "The Maiden's Blush peaches are just on the turn. I must pickle them to-day, or they'll get too ripe. I always go by Grandma Brittingham's rule; it calls for peaches on the turn."

"Oh, let me help you make pickles!" said Eulalie, trembling with eagerness. "I should love to help."

"No," said her mother-in-law; "there can't anybody help me make peach-pickles. I always follow grandmother's rule." Little telepathic sparkles from her eyes said, "You stay in here."

Leroy's wife sat in the parlor and looked out at the fields where Leroy used to run barefoot. When she tired of the fields, she looked at the toys on the mantle and the photographs in the album.

Mrs. Powell was stirring the pickle that had been carefully compounded according to Grandmother Brittingham's rule, when she looked up and perceived the stranger from the parlor. She was holding in her arms the large plush album from off the center table.

She looked appealingly at her mother-in-law, and her cheeks were a beautiful pink color. "This baby—this little fellow in the front," she said, holding out the album, "isn't it—your—my—our—isn't it Leroy, mother?"

"Yes," answered Mrs. Powell, without ceasing to stir the mixture in the kettle, "they're likenesses of Leroy. I had a good many of them taken, for I knew some day they'd be all I'd have left of my boy."

"Oh!" said the girl, as if something had hurt her.

"The portrait is made from the same photograph I wear in my locket," she confided. "I think it is the best of any; but these dear baby ones are so cute." She looked pleadingly at the older woman, as if silently praying for a word of explanation, comment or further knowledge of a most interesting subject. There was none. Grandmother Brittingham's rule evidently called for long and vigorous stirring.

Eulalie went out of the kitchen and sat down on the back steps and opened out the album across her knees. Through the open window Leroy's mother could see her dimpling smile as she turned the leaves. She saw her bend and kiss each picture tenderly many times. Then the stirring ceased.

"Here," said Mrs. Powell, coming out where Leroy's wife was sitting on the steps, "here is a piece of clean tissue paper. If you must do that, put it on the pictures. I wouldn't have those likenesses spoiled for anything—they're all I have left of him."

The red blood came up into the girl's face. "Oh!" she said again painfully. "I'm sure they're not hurt, mother. You don't know how much it means to a—a wi—to any one to have a little glimpse back into the childhood of—of some one very dear. It was so thoughtful, so good of you, to have all these little pictures made." She rose and stood facing her mother-in-law. The older woman was the taller, and the girl looked up wistfully into her face. "Would you mind telling me how old he was when this first one was made?" she said. "Not more than six months, I guess, and yet I knew it was he before I asked you. The dear little nose is perfectly natural. And this one in trousers—are they his first trousers?"

Mrs. Powell came and looked over the girl's shoulder at the album. "Yes; they were the first ones he ever wore," she said. "I cut them over a pair of Wesley Crump's. He was 'most too little to put them on; but Wesley had them, and Leroy cried for a pair. I can show you the breeches!" she said, spontaneously. "They are packed away in camphor up in the garret."

"I forgot to tell you," called Mrs. Powell from the turn of the stairs, "he was just four months and eight days old when his first picture was taken."

She descended the stairs in an incredibly short time with the abbreviated breeches—intact; an infant's long dress hung across her arm; a soldier's cap; a small drum, with the head bursted out, and a rocking-horse with a broken leg.

"I thought I would just bring these things down and let you see them," she panted from her sudden flight up and down the stairs. "This is the little rocking-horse he is standing beside in the picture marked 'Age Three.' And this is the little drum and cap he has in the one marked 'Age Five.' And this is the very dress he wore when he had his first picture taken," she explained, holding up the long white robe. "He was christened in it, too. That little sheep he is holding in the one marked 'Age One Year'—Leroy took his first step for that sheep. Maybe you noticed it on the parlor mantel. If you will come into my room, I can show you just about where it was. Leroy was born in this room," she said, as she opened the door. "He spent all of his life here with me, until he was old enough for college. It was his father's wish that he should be educated—and mine, too."

There was a rapt and beautiful look on the girl's face, as she followed her mother-in-law into the room. She was, as it were, stricken dumb. The color came and went in her face, and her bosom heaved with tremendous emotion.

Mrs. Powell did not notice. She was conscious only that she was talking of Leroy. Nobody before had ever cared to listen to her talk about Leroy as much as she liked. This girl did not try to head her off, as envious, contemporary mothers had so often done. With eager, parted lips she hung on every word, while the mother went over the dear past again.

"It was just about here that Leroy took his first step," continued Mrs. Powell, indicating a space near the middle of the room.

"Every time his father went to a store in town he brought the baby some kind of toy. He had just come from town and brought a little sheep. He was going to give it to the child, when I took it and held it out—so. Leroy let go of the chair he was holding onto and took three steps. I wish you could have seen how proud he looked. I can see him now—just as plain! That time was mine," she said dreamily. "Nobody can take it from me."

With a little cry, Leroy's wife held out her hands to her mother-in-law. "Let me take my first step here to you, mother!" she sobbed. "You had him all to yourself such a long happy time. Let me help you love him now! And we must love each other, too, because we are the two women in all the world who love him the best."

"You shall, you shall—my dear child!" said Leroy's mother, and she caught the girl in her arms and soothed her upon her breast.

"Mercy! Celestine, is your sugar-barrel afire?" Mrs. Crump loomed unannounced and smiling in the doorway. Very gross and mundane she appeared, as she broke into the sacred atmosphere of the room. One glance told her that it was no place for her. She turned and retreated to the kitchen where the peach-pickles were boiling over on the stove. She set the kettle off and cleaned the burned fruit and syrup from the top of the stove. Then she sat down and laughed. "I'll 'low she didn't make pickles by Grandma Brittingham's rule this time!"

Our Puzzle School

Conducted by Sam Loyd

ALL puzzle books give that famous address that the person gave who wrote to

W O O D
J O H N
M A N E

which it is said reached the intended destination of John Underwood, Andover, Maine; but correspondents fail to mention that the printed letter tells where the epistle was sent from:



And if we are not very much mistaken, the following illustration was in-



tended to give an idea of the date. Can you decipher both puzzles?

A Base-Ball Problem

There was a game on between the "Sockets" and the "Sluggers." The Sockets went first to the bat and at the end of the eighth inning neither team had scored a run. The final score at the end of the ninth inning was 5 to 2. Which side won, the Sockets or the Sluggers? And why?

A Clever Puzzle

Can you decipher the following hidden cryptogram sentence?
1YY1 own conceit.

A Rebus

In every hedge my second is,
As well on every tree.
And when the school-boy acts amiss,
It often is his fee.
My first, likewise, is always wicked,
Although it does no sin.
My total for my first is fitted,
Is made of brass or tin.

To Tell a Person's Age

There are many ways of performing the popular trick of telling a person's age, but the following is the best and will prove very entertaining for an evening party:

Let the person whose age is to be discovered do the figuring. Suppose, for example, a girl is 13 and was born in November, put down the number of the month. (November is the eleventh month.)

	11
Multiply by 2.....	2
	22
Add 5	5
	27
Multiply by 50.....	50
	1350
Add age (13).....	13
	1363
Subtract 365	365
	998
Add 115	1115
	1113

As she answers 1113, tell her her age is 13 and November is her birth month. This test never fails up to 100. In computing ages under 10, a cipher will appear prefixed in the result, but no notice need be taken of it.

Riding Against the Wind

Here is a pretty mathematical problem which will interest the school-children, as well as some of the teachers, for the reason that the popular answer is quite incorrect, as the principle involved is not generally understood.

A bicycle rider went a mile in three minutes with the wind, and returned in four minutes against the wind. How fast could he ride a mile if there was no wind?

Concealed Geography

In the following sentences the name of some town or country is concealed. Now see if you can guess all of the answers?

71. When in India Lord Raglan cast Eros, the blind dog, at his feet; Venus laughed.
72. Trust no past, fear no future. (A river.)
73. Stocks, or rent, or what, make the big investment?
74. Did you ever read in Goldsmith of the curse of ambition?
75. The wounded are borne off the field on litters. (An island.)
76. Not money, but base love of money, harms.
77. "A widowed bird sat, mourning for her mate, upon a wintry bough." (River.)
78. Tall or short, fat or lean, shall make no difference here.
79. The young lady drinks a lemonade.
80. But a coma makes a great difference sometimes.
81. Uncle Will, I am just sporty enough to challenge you to a foot-race.
82. Does any one say that the Spanish-American War was wicked?

83. They have neither spooks nor witches down East now.
84. Scapo, who threw the disc, ran to Nero and embraced him when he saw that he had won.
85. That little brat is bonneted with a stocking.
86. A surveyor, looking at the debris, told me the wreck was fearful.
87. Sacred music owes much of its success to the opera.
88. Let no women or man dye their hair. (Province.)
89. Several banian trees were required to shelter the Fakir of Ava. (Country.)
90. One lie generally necessitates many.
91. It is said that Nepos tended bar at Rome.
92. Men are ruined through entertainments of too great magnificence.
93. If you want an answer from a daw, ask a question. Caw caw caw.
94. You must hang in the hall a brad or tack to put hats on. (Country.)
95. A mad dog ran a dangerous race with a policeman.
96. The ill-fated Io was changed by Juno's jealousy to a heifer. (State.)
97. Let me use my own means. (River.)
98. France has been our ally on several occasions.
99. Man is a creature of a day.
100. France is treacherous, but Prussia may perhaps be trusted. (Country.)
101. Never is error long triumphant. (River.)

A Problem

As I was beating on the meadow grounds,
Up starts a hare before my two gray hounds;
The dogs, being light of foot, did fairly run,
To her fifteen rods, just twenty-one;
And the distance that she started up before,
Was six and ninety just and no more;
Now I would have you clever folks declare
How far they ran before they caught the hare?

Answers to the Puzzles in April 10th Issue

Aladdin arranges the pieces of his wonderful lamp in the following ways.



A Charade: Farewell.
Bidly was eighteen, forty years ago.
Concealed Geography: Artois, Smyrna, Nahant, Marblehead, Amherst, Lawrence, Persia, Madeira, Andover, Salem, Roxbury, America, Malta, Pisa, Umbago, Toledo, Utah, Sacramento, Panama and Oahu.

In the sentence which concealed the word "Pisa" the word "up" was left out after "waked." We regret that the mistake occurred.

A puzzling Query shows that the man is preparing a great feast because he is making bank wet.

Fifty prize puzzle books will be sent to those sending the best answers to Sam Loyd, Box 826, New York.

Tell what books you have received so as not to receive duplicates.

Send Secret Messages to Your Friends



These wonderful post-cards have been appropriately named the "ALI BABA" post-cards. People, big and little, old and young, are going wild over them everywhere. They are all the rage in London, Paris, New York and the other world centers, with the craze fast spreading.

ALI BABA was an ancient necromancer. He performed feats of magic unequalled. The name as applied to these cards is wonderfully fitting, for they are the most wonderful production of the post-card art.

On these cards you can send Secret Messages to Your Friends, written by your own hand, on an apparently blank card open to the inspection of every one. Yet no one can read the message but the one for whom it is intended.

The Wonderful New Post-Cards

are put up in assortments of ten different subjects, handsomely printed, with a supply of the wonderful invisible ink, special pen for writing the messages, and full directions for use.

If you wish one of these sets you must send your order to us at once, as the demand promises to exceed our supply. When we send the first cards we will tell you how you can secure other supplies.

OUR OFFER

Send us at once only three eight-month trial subscriptions to FARM AND FIRESIDE, at 25 cents each, and in return we will send you a complete ALI BABA post-card set, with all the necessary supplies. All charges paid.

Send at Once
to
Farm and Fireside
Springfield, Ohio



This Air-Rifle Without Cost For You

This is the wonderful King Air-Rifle. It is a Repeater—shoots 150 times without re-loading. It is just the rifle for a Boy. Here is your chance—you can get it without cost.

Would You Like to Get One?

You can get one without spending a cent. FARM AND FIRESIDE will help you earn it. You would be glad to do just a little work to get it. Thousands of happy boys already have earned a rifle easily from FARM AND FIRESIDE.

Fill out and mail the coupon below and we will send full particulars by return mail.

A True Shooter

Boys, this rifle shoots accurately. Look out, crows and hawks, if a boy ever gets after you with this King Air-Rifle. It cultivates trueness of sight and evenness of nerve.

It uses no powder—makes no noise—uses air and shot. You will have use for it every minute.

Expert workmanship has made this a wonderful gun. This rifle is provided with pistol-grip, true sights, and is so strongly made it is almost impossible to get out of order. It is extremely simple in construction.

Any child can use it and become an expert shot. It makes boys grow to be manly, self-reliant men. Every boy should learn to handle a rifle. It makes them healthy and strong—sends them out of doors.

Any boy would be happy to get this rifle. No wonder every boy should want one, we are glad to help every boy get one—without having to pay a cent for it.

How to Get It

You can get this wonderful rifle without spending a penny if you will do a little work for it. Send in the coupon to-day to the Rifle Man or just write a post-card—say you want to earn a rifle. We will be glad to help you.

Write To-day

For Our Boys

The Rifle Man
FARM AND FIRESIDE, Springfield, Ohio.
Please tell me how I can get the famous King Air-Rifle without having to pay a cent for it.

Name

Address

Where It Isn't Quite So Cold

By Eugene Wood, Author of "Back Home," "Folks Back Home," Etc.

Illustrated by Fred E. Lewis

UP THERE in the Amen Corner of Accepted Truths are a lot of such old Uncle Billy Hardheads as "A rolling stone gathers no moss," and "Darwin teaches that men came from monkeys," and "Legumes gather nitrogen from the air," and "Fish is a great brain-food," and "Twice two is four," and—oh, a whole lot of old codgers with their lips pursed up and all ready to say to any new idea: "You can't learn me, nothin', young feller."

They sit up there in the Amen Corner of Accepted Truths, out of the draft and close to the stove, quite comfortable and much respected. And about once in



"Old Uncle Billy Hardheads"

every so often (or maybe oftener than that) somebody up and declares that one of these old skidamalinks, maybe the one that has sung through his nose louder than anybody, is a hypocrite and a not-so, and starts in to throw him out, since he won't go out quietly. And then the row in the congregation begins, for, instead of forming a ring and seeing fair play, we all take sides, naturally dividing off into those who respect the aged, whether they are not-so's or not, and into those who take up with any fool notion that comes along just because it's different.

I am not going to give it away which side I belong to. That's my concern, not yours. And I'm not one of those who delight in stirring up trouble in the congregation. I am all for peace at any price whatsoever, and I hate an argument worse than I hate eating a meal's victuals. But if there should happen to be anybody about just naturally spoiling for a fight, it doesn't make any difference with whom or what about so long as it's a fight, I'd like to call his attention to an old skeezicks up in the Amen Corner of Accepted Truths that, if I were not, as I say, a peaceable man, I'd slap the face off of and take him by the back of the neck and boot him all the way down the aisle and out the front door. And that's the pop-eyed fraud with the long silvery curls that goes by the name of "Westward the Star of Empire Takes Its Course."

I will admit that there are brilliant examples of the star of empire doing that in certain exceptional instances and for a few years at a time. But all the sparkling fountains in all the public parks can never overthrow the rule that water runs down hill. Water and conquest go in any direction under pressure, and the star of empire has taken its course eastward quite frequently, as witness Alexander the Great, Pompey, the Crusaders, the Venetians, the British and the Dutch in the East Indies, the British in India and Australia and New Zealand, or, if you can call control of a nation's finances "empire" and can figure forth a dollar as a star, its course in our land is toward the east where are Wall Street and the Waldorf-Astoria, the one to cut a melon in, the other to cut a splurge in.

People and peoples move to where life is more comfortable for them. And if you'll look into the matter, you'll see that whatever the lateral movement to the east or to the west, in the large average of nations, and the long run of centuries, they have moved southward, "where it isn't quite so cold," out of the gray and gloomy North into the Sunny Southland. When our folks removed from York State to "the far West" of Ohio and Indiana, they went South; even when, long ago, they crossed the wide Atlantic that they might worship after the dictates of their own conscience, and take a stick to anybody else who had the gall to want to worship after the dictates of his insignificant two-by-four conscience, they went South. It is hard to believe that New York is on a line with Madrid, Spain. But there's the map. Go look for yourself.

This old fraud with the pop-eyes and silvery curls, with the assistance of another one called "the Aryan race" (by the way, this one got kicked out of the Amen Corner before he fairly sat down in it), made quite popular for a while the notion that Europe was settled by "Aryans" moving westward from Persia and thereabouts. But that's all gone by the board and it is pretty certain now that Greece and Rome and all around the Mediterranean were conquered and peopled by those who had got sick and tired of hopping out of a warm bed on zero mornings to light a fire. The Goths and Vandals who raided Rome so often, the Norsemen who hacked their mark as far as Asia Minor, the Crusaders—Yes, I know they said they wanted to rescue the Holy Sepulchre from the defiling hands of Turks. But you mustn't always go by what "they say." The fact of the matter is that all these came south to dodge the coal-bill. Even in North America the movement of the conquering tribes was always from the frozen Northwest. It is my personal belief that every time the Goths and Vandals went for Rome it was because the magazines had begun to advertise kerosene heaters, and they knew by that that winter was coming again. "Again? Again? Oh, laws! Shall we stand for it?" And they concluded that they couldn't and wouldn't.

"Westward the star of empire takes its course," eh? Empire has a lot to do with trade, and while there is a good deal

of trading back and forth among countries that produce substantially the same kind of things, yet if we forget the tropic-grown pepper and spices of ancient times, and the coffee and tea of our own times, the oranges and bananas and early vegetables, one thing we must not forget in this our own electrical age which dooms the star of empire to take a southern course, and that is rubber. Without electricity where is modern civilization? Without rubber where is electricity? And they don't grow rubber up around Duluth.

Every so often there is an instinctive movement of the peoples toward the Sunny South. It will be fifty years, come next planting-time, since there was such a large folk-migration from the frost-bit North, a horde of young fellows, mostly about sixteen years old, looking for excitement. Their regular job was saving the Union, but there was supposed to be excitement outside of office hours and sometimes inside of office hours. They were much like any other army of invaders. I think Attila would have recognized them. Attila, I need hardly say to you, was some conqueror. But I do not think he would have approved of the way the Civil War was carried on. He would have said it was altogether too civil. He would have said it was too Miss Nancyish, this thing of trying to kill a man one minute and trying to cure him the next, shooting at a man one minute, and the next minute running over to him and crying: "Oh, did I hurt you? Oh, I'm so sorry!" and getting him a drink of water and fussing over him with all this Red Cross and Sanitary Commission business. He wouldn't have approved of it at all. He would have told you it would only make trouble. The way to do when you go South for the winter—or, rather, from the winter—he would advise, would be to kill off everybody, except the good-looking young ladies. You kill off the braves because you have to in order to get the country away from them; you kill off the citizens, the men of undoubted probity and integrity, the statesmen and the editors, who stirred up the muss in the first place, but wouldn't shoulder the musket when it came to fighting; you kill off the real old people and the sickly



"That they might take a stick to anybody else who wanted to worship after the dictates of his conscience"

because they are a useless expense. Those who holler and cry and beg for mercy, big, strong hulking fellows that are afraid to die, you send up to Pittsburgh to work as captives in the steel mills there. You kill off everybody that can remember what has happened and so can hold a grudge. All except, as I say, the pretty girls and these you marry to your young conquerors. And keeping house for a conqueror and nursing a new baby every year kind of tends to take your mind off old grudges. So that as soon as ever the buzzards get done with their work the white-winged dove of peace comes on the job immediately. If you lick a man with a feather-pillow, he'll never forgive you for it as he would if you had done it with an ax, but fifty years later he will be avenging Appomattox by poisoning your dog and voting the Democratic ticket.

Also with all these leading citizens and prominent financiers and men of undoubted probity and integrity out of the way, there is no longer any occasion to lament: "What this country needs is a lot of first-class funerals." I hope it is quite safe at this distance of nearly half a century from a great southward invasion to joke about it a little and to say that if they had taken a lead out of Attila's book, you would sooner hear the folks up around Mankato apologizing for the looks of things by: "You see, this part of the country suffered a great deal from the Sioux uprising and never really recovered from it," or the folks in the business district of Chicago explaining that the big fire did a lot of damage and that's how it was set



"You kill off . . . all except . . . the pretty girls and these you marry to your young conquerors"

back so—I say, you would sooner hear that kind of talk up around Mankato or in the down-town section of Chicago than south of Mason and Dixon's Line.

The sickly sentimentality of '61-'65 prevented the flower of our young manhood from acquiring land in the Sunny South in the natural way, in the amusing way and in the comparatively inexpensive way of murdering its previous holder, so that if we gratify our inborn craving to settle where it isn't quite so cold in winter, we have to do so by purchasing land, which is always expensive in both time and money.

It was this thwarting of the folk-movement toward the South that incidentally forced the invention of steam-heating. It drove the population West until there was no more West to go to. Latterly population has taken a trend toward Canada where the soil is as deep as the winter is long, which is saying much. Only I just don't remember how, if the alluvium is twenty-five feet deep, you can make much use of, say, twenty feet of that underneath the five top feet. If you could rig up some kind of an arrangement so that you could turn your farm over like a flap-jack when it was worn out on one side, I should think there might be some excuse for going up to where it freezes up as tight as bricks on September fifteen and never thaws out enough to plow till June fifteen, and where, in order to make up for the shortness of the growing season, the days last all night and the plants work double tides.

Soil so naturally good that it doesn't make much difference what a fool of a farmer a man may be is a great inducement to go most anywhere, even beyond the last ultimate link that binds one to a market and the makings of a cigarette, even to some place where it is a good bet either way: (1) That the Indians will get you before dinner or (2) that they won't get you till along about three in the afternoon. If farming is the only way you know of to make a living, and the only kind of farming you know is to raise wheat year after year on the same land, burn up the straw and pile up the manure, then, to be sure, you must go farther and farther in search of this deep alluvium. Farther and farther North, until it becomes a problem of whether alluvium even one hundred feet deep can counterbalance the asperities of a climate where brass monkeys are all muley because their horns were frozen off before they were born. It begins to be a question whether the hardy pioneer had better pay two hundred dollars an acre for good farm land or take the light sandy soil of the South only two or three feet above a hardpan that will hardly allow dynamite to go through, a soil that has had the humus burned out of it by spring burning-over, but in the midst of a market which pays ten cents a quart for milk (eleven tickets for a dollar) and where it is a public scandal when the thermometer goes down to seventeen—above, above, man. Above, of course. What d'ye think I'm talking about? Fourth of July in Alberta? No. I'm talking about the dead of winter here in Alabama. As I was going to say, it begins to be a question whether the hardy pioneer will not do better to put some of that two hundred dollars per acre into cows wherewith to make good soil out of this light sandy loam of Alabama, where the roses bloom about forty-six weeks out of the fifty-two, where all the butter comes from Wisconsin and where, besides the standard products of a farm, corn and cotton and hog-meat and all such things as a man can raise and still be an honest man, there are such things as shade tobacco and Satsuma oranges and pecans and figs, things which should be more properly classified under the head of sporting events than gainful operations.

I begin to feel a little bit uneasy when you look at me in that funny way and start to sidle away from me. I have no land to sell for myself or for anybody else. All this language has come from the bottom of my heart and not from the top where the language comes from that draws down thirty-three and a third per cent. commission. I am as well aware as you that all the three-card monte sharps, all the gold-brick swindlers, all the confidence men, all the greengoods operators, all the mining-stock promoters, all the stock-exchange experts who can invest your money for you so judiciously that you'll never see it again. All these gentlemen, I say, have entered upon real estate, and especially Southern farming lands propositions, as being that branch of their profession likely to be most remunerative. I had heard so and when I read some of the prospectuses I knew so. When I encountered these words: "A chance for the wage-earner to get in for once on exactly the same basis as the moneyed man," then I knew that the brick was solid gold and that the only reason the fellow parted with it was because his poor old mother was dying in a far-off city, and calling for him, and the bank was shut, and he needed the money. When I read: "Each of these

orchards will produce a revenue averaging approximately three hundred dollars per acre per year. Think of it! The original purchase price in return in one year." I could tell exactly which shell the little pea was under, because I saw it go under. When I looked at the pretty picture entitled: "Home of Axel Hederstedt," I wondered if Axel was the man that bought land down here, sight unseen, taking the agent's word for it that the fruits shown in the photographs of the loblolly pine were pineapples. (And, by the way, whenever you find a village down around these parts looking particularly neat and pretty and kind of swept up, be sure that if the men in it are not named Axel they are named Ole.)

Almost all kinds of men have a hankering to be where it isn't quite so cold in winter, but the men named Axel and

ole are particularly that way. That's why the Norsemen have hacked their mark all along the Mediterranean. It's pretty alluring to most anybody to think that you can grow your own bananas, even if they do taste like plain paste, and still be in the United States. Oh, by the way, there is a land syndicate down this way whose head man bought a bunch of bananas over in Mobile and lugged it all the way so as to tie 'em on a banana-plant and get a good attractive picture for the prospectus. Buying fancy wrapper-leaf for exhibition purposes you can understand, because the syndicate is selling tobacco land, but lugging those bananas all the way over from Mobile was just done out of the goodness of his heart because they don't sell land for banana culture. If you are thinking of coming South where it isn't quite so cold, raising tobacco is something you want to look into—carefully. You can easily make your fortune at it, for the Tobacco Trust has solemnly vowed it will take all the tobacco that can be raised on this particular land and will pay—let me see now. Was it five dollars an ounce or five dollars a pound? I forget. But that's a detail. The main point is that somebody's going to make a barrel of money out of this thing. Whether it is the investor or the syndicate that bought the land two years ago for two dollars an acre and is now selling it for one hundred an acre is something you will have to decide for yourself.

And I declare if I haven't gone and lost the figures that you can make raising Satsuma oranges, which are ever so much sweeter and better to eat than common oranges and which have this further advantage that they respectfully but firmly decline to get frost-bitten. After the first three years I think it ciphers out something like forty-eight cents a minute every day in the year on a five-acre grove.

And don't overlook pecans. Let me read you something: "One acre of our land planted with twenty budded or grafted paper-shell pecan-trees should yield annually three hundred dollars at ten years from planting and double that at fifteen years, grad-

ually increasing for generations." Let's see. You want three thousand dollars a year, don't you? I think that's the figure you mentioned. Buy ten acres. Do you see how simple it is? Do you see it? Well, then, buy ten acres. And ten years from now you'll be making three thousand a year with nothing to do but pick pecans. And that isn't all. Fifteen years from now it will be six thousand dollars. That is, it "should be." And that isn't all. Your little Jenny grows up and gets married. And the fellow turns out to be a scamp and leaves her. Leaves her and the children. Fear not. The pecan-trees will keep on increasing their yield and their price for generations and generations. Isn't that something worth considering?

I saw eight of the prettiest pecan-trees the other day I ever laid eyes on. Thrifty as you please. All about fourteen years old. Fine nuts. About as long as a hen's egg, but slimmer. Paper-shells, yes. You could take two of the nuts and by simply squeezing them together could crack the shells and pick out the kernels. Two of them were all the man could spare. He got his first yield last fall, and off the eight trees he had nearly a quart, so that he had to be a little stingy with them. He was right proud of his first crop of pecans, I can tell you.

But, still, if I were going to farm it in the Sunny South where it isn't quite so cold, I'd let the star of empire take its course, if it wanted to, toward the real estaters and land speculators and where the unreconstructed poison the dog and stick up the prices on you. I'd let them fill it up with gilt-edged talk about all sorts of sporting propositions, like Satsumas and pecans. But I should look for a location where I could settle among Northern people, where I could get the land for nothing by simply paying taxes on it, and then I'd start in raising that crop which is harvested twice a day and which enriches the land as you go along. I know of just such a proposition. Ten cents a quart looks good to me.

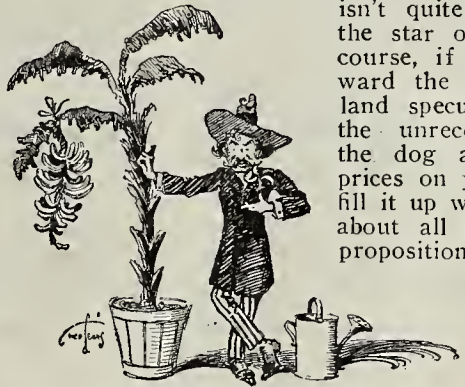

"A bunch of bananas to tie on a banana-plant and get a good picture for the prospectus"

"Shikata Ga Nai"

By Forrest Keith

VISITORS to Japan who remain long enough to come into touch with the people find themselves much impressed by the perfect serenity of the Japanese woman. She seems never to lose her self-poise and knows nothing of the worry and fretfulness of the American woman. No one ever heard of a Japanese woman "going all to pieces" over any domestic calamity. Should her clothes-line break, she would maintain her self-poise and say, "Shikata ga nai."

These words, we are told, have different shades of meaning, but their general import is that it is of no use to worry over the inevitable. It is in a sense the little Japanese woman's way of saying it is of no use to cry over spilt milk. The words seem rather stoical at times, but they are of quite as much avail as tears and hysteria would be. This perfect self-control of the Japanese woman is not due to a total lack of feeling, but to her wise and philosophical conclusion that all worry and fretfulness are useless and that they can do nothing but create unhappiness in the home. It is a cheerful and wise philosophy, but one not easy for the American woman to adopt. She must achieve almost a moral triumph in order to say with serene calmness "Shikata ga nai" when the fates seem to have combined to make all of her domestic affairs go wrong. But if she only could and would say "Shikata ga nai" to these misfortunes her wrinkles would be fewer and her home would be happier.

The Japanese women of all classes train their children from earliest infancy to say "Shikata ga nai" to every little trouble that assails them and this is one reason why one rarely sees a Japanese child crying or fretting over anything. An American resident of Japan says in regard to this: "I have again and again seen a little toddling mite fall flat on its face, giving its little nose a fearful bump. It lies perfectly quiet for a full minute, getting over the shock, I suppose, and then gravely picks itself up and trots off to play."

Contrast this with the wild, screaming yells of the average American child when it bumps its nose. The woman who can control her emotions, who can say "Shikata ga nai" to the petty annoyances of every-day life, is preventing the waste of a lot of nervous force.

Goin' Fishing?

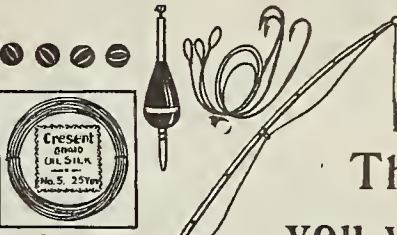

Then you will want this fine three-piece bamboo rod, complete with reel, line, sinkers, float and six hooks

We have selected this fine, three-piece bamboo rod, click reel, oil silk line, sinkers, float and assortment of hooks, as

A Gift to You

We particularly want you to have this bait-casting rod, and, of course, you'll want the other supplies, especially when we explain that the complete outfit will be sent without one cent of expense to you.

For particulars how to obtain this outfit, write at once to

FARM AND FIRESIDE
SPRINGFIELD, OHIO

Some Good Jokes

Heroic Treatment

LITTLE Willie wore his stocking inside out, a habit shocking. To correct this naughty whim, Mother turned the hose on him.
SAM S. STINSON.

The Boy and the Professor

"I WAS mimicking Professor Bore yesterday, and he caught me."
"What did he say?"
"Told me to stop making a fool of myself."—The Wasp.

Thorough

THE NEW COOK—"I'm thot sorry, mum, but I clean forgot to take the turkey out of the oven."
MISTRESS (four to dinner in fifteen minutes)—"Is it burnt?"
THE NEW COOK—"Is it burnt! I give you my word, mum, it's a heap of ashes!"
JACKSON PETERS.

Suited Norah

NORAH had been guilty of what was considered an indiscretion, so the mistress of the house called her to "step the carpet." "If such a thing occurs again, Norah," said the mistress, "I shall have to get another servant!" And Norah said; "I wish yer would—there's easily enough work for two of us!"—New Zealand Free Lance.

Hitting It Up

A GUEST in a Cincinnati hotel was shot and killed. The negro porter who heard the shooting was a witness at the trial.
"How many shots did you hear?" asked the lawyer.
"Two shots, sah," he replied.
"How far apart were they?"
"Bout like dis way," explained the negro, clapping his hands with an interval of about a second between them.
"Where were you when the first shot was fired?"
"Shinin' a gemman's shoe in de basement of de hotel."
"Where were you when the second shot was fired?"
"Ah was a passin' de Big Fo' depot."—The Herald and Presbyterian.

The Retort Courteous

THE LADY OF THE HOUSE—"I hope you are habitually truthful, Bridget?"
THE NEW MAID—"Yis, mum, I am on me own account. I only tells lies to the callers, f'r th' missus."—Cleveland Leader.

She Wanted to Help

ONE day last summer little Marion, aged three, was placed on a chair in the kitchen to watch her grandma shell peas for dinner. After watching with much interest for a few minutes, she turned to the maid, Julia, and said, "Dulia, get me down, I want to hup (help) gonma unbutton the peas."—The Delineator.

A Warrior's Gratitude

SUNDAY-SCHOOL TEACHER—"Well, Johnny have you had anything during the week to be especially thankful for?"
JOHNNY—"Yes, ma'am."
SUNDAY-SCHOOL TEACHER—"What was it?"
JOHNNY—"Billy Jones sprained his wrist yesterday and I licked him for the first time."—Chicago News.

The Use

MRS. GIVEM—"What will you do with this dime?"
WEARY WILLIE—"Pay for a musical education, lady."—Harper's Bazaar.

The Clock Stuttered, Too

A DROLL sort of a fellow, given to stuttering, met an old college chum on the street. They had some hours together and other things. As the tardy one stealthily ascended the stairs on reaching home, out of the darkness came his wife's voice.
"What time is it?" she asked sternly.
"It is j-j-j-just one," he stammered. The words were scarcely uttered when the old-fashioned clock on the landing gave four laborious strokes.
"Do you hear that?" she asked sharply.
"But my d-d-dear," he rejoined pleasantly, "y-you mustn't mind that k-k-clock. It's l-l-l-like me."—Success.

The Right Way to Buy Soda Crackers

—and the *simplest* way. Ask for them by name—and the goodness will take care of itself. Buy

Uneda Biscuit

Then, no more broken, soggy, stale or exposed soda crackers. Uneda Biscuit come in individual packages that hold just enough for each soda cracker occasion. *Fresh* when you buy them. *Whole* when you open the package. *Crisp* as you eat them.

A number of five cent packages of Uneda Biscuit is a wiser purchase than a quantity of ordinary soda crackers in wooden box or paper bag. Never sold in bulk.

NATIONAL BISCUIT COMPANY

BOOKS —FOR— GIRLS



READ THIS LIST

- Adventures of a Brownie.....Mulock
- Alice's Adventures in Wonderland.....Carroll
- Andersen's Fairy Tales.....Andersen
- Arabian Nights.....
- Aunt Diana.....Rosa N. Carey
- Averil.....Rosa N. Carey
- Bad Little Hannah.....L. T. Meade
- Bailiff's Maid, The.....E. Marlitt
- Bella's Blue Book.....
- Black Beauty.....Anna Sewall
- Book of Golden Deeds.....Yonge
- Brownie of Sanford.....Carrie L. May
- Bunch of Cherries.....L. T. Meade
- Cuckoo Clock.....Mrs. Molesworth
- Daddy's Girl.....L. T. Meade
- Deb and the Duchess.....L. T. Meade
- Dog of Flanders.....Ouida
- Erl Queen.....N. Von Eschstruth
- Esther.....Rosa N. Carey
- Faith Cartney's Girlhood.....Mrs. A. D. T. Whitney
- Four Little Mischiefs.....Mulholland
- Frances Kane's Fortune.....L. T. Meade
- Girls and I.....Mrs. Molesworth
- Girl of the People, A.....L. T. Meade
- Girl in Ten Thousand, A.....L. T. Meade
- Good Luck.....L. T. Meade
- Grimm's Popular Fairy Tales
- Honorable Miss, The.....L. T. Meade
- House That Grew.....Molesworth
- Helen's Babies.....John Habberton
- Jackanapes.....Mrs. Ewing
- Jarl's Daughter.....Mrs. Burnett
- Leona.....Mrs. Molesworth
- Late Miss Hollingsford, The.....Mulholland
- Little Lame Prince.....Miss Mulock
- Little Susie Stories.....Mrs. Prentiss
- Merry Girls of England.....Meade
- Naughty Miss Bunny.....Mulholland
- Next Door House.....Molesworth
- Old, Old Fairy Tales.....Miss Mulock
- Only the Governess.....Rosa N. Carey
- Our Bessie.....Rosa N. Carey
- Out of Fashion.....L. T. Meade
- Pilgrim's Progress.....Bunyan
- Polly, A New Fashioned Girl.....Meade
- Princess of the Moor.....E. Marlitt
- Queechy.....Mrs. Wetherell
- Rab and his Friends.....Brown
- Robin Redbreast.....Molesworth
- Ruth Lovell.....Carrie L. May
- School Favorite.....Mrs. Meade
- Six Little Princesses.....Prentiss
- Six to Sixteen.....Mrs. Ewing
- Stepping Heavenward.....Prentiss
- St. Cuthbert's Tower.....Florence Warden
- Sweet Girl Graduate.....Mrs. Meade
- Sylvia's Burden.....Carrie L. May
- Tales from Shakespeare.....Charles and Mary Lamb
- Taming a Tomboy.....Von Rhoden
- Tanglewood Tales.....Hawthorne
- Those Western Girls.....Florence Warden
- Three Bright Girls.....Armstrong
- Through the Looking Glass.....Carroll
- Rime of Roses.....L. T. Meade
- "Us".....Molesworth
- Very Odd Girl, A.....Armstrong

These books, as you will see from the titles, are standard works peculiarly suited to the girl. The printing is clear, on good paper, and the cloth bindings are substantial and attractive.

To obtain your choice of any one of these fine books for girls, send us only three 8-month trial subscriptions to FARM AND FIRESIDE, at 25 cents each. We will then send you, postpaid, any book from the above list that you may select. Send all orders to

FARM AND FIRESIDE, Springfield, Ohio

Practical Clothes



No. 1352—Double-Breasted Russian Suit
Pattern cut for 2, 4 and 6 year sizes. Quantity of material required for medium size, or 4 years, four and one half yards of twenty-four-inch material, or three yards of thirty-six-inch material



No. 1441—Boy's Pajamas
Pattern cut for 2, 4, 6, 8, 10 and 12 year sizes. Material required for medium size, or 6 years, three and one half yards of twenty-seven-inch material, or two and one eighth yards of thirty-six-inch material



No. 1540—Dressing-Sacque With Sailor Collar
Pattern cut for 32, 34, 36, 38, 40, 42 and 44 inch bust measures. Quantity of material required for medium size, or 38 inch bust, four and three fourths yards of twenty-two-inch material, or two and seven eighths yards of thirty-six-inch material



No. 1520—Double-Breasted Tucked Waist
Pattern cut for 34, 36, 38, 40 and 42 inch bust measures. Quantity of material required for medium size, or 38 inch bust, four and three eighths yards of twenty-four-inch material, or two and one half yards of thirty-six-inch material



No. 1364—Shirt-Waist With Scalloped Collar
Pattern cut for 34, 36, 38, 40 and 42 inch bust measures



No. 1549—Outing Shirt
Pattern cut for 32, 34, 36, 38 and 40 inch bust measures

No. 1332—Tunic Skirt With Flounce
Pattern cut for 24, 26, 28 and 30 inch waist measures. Length of skirt all around, 42 inches

No. 1550—Outing Skirt With Facing
Pattern cut for 22, 24, 26, 28 and 30 inch waist measures. Length of skirt all around, 40 inches

THOUGH Fashion is no longer the domineering dame she used to be, yet there is one rule which she holds to with rigid persistency, the right costume for the right occasion. The inappropriate costume is always in the worst possible taste and proclaims at once the ignorance of its wearer. And for this reason every woman should give as much thought to her inexpensive summer dresses, and when they should be worn, as she does to her more elaborate winter clothes.

Illustrated on this page are two very smart summer gowns, which can be made of madras, gingham, linen or lawn, and yet they could not be worn for the same occasions. The one with the overskirt and scallops is a dainty dress for church, sociables and afternoon wear, while the severely plain tailor-made outing suit is not only appropriate for sports and out-of-door pleasures, but it is an exceedingly practical dress for use around the house or for working in the garden or yard.

Madison Square Patterns

THESE are the patterns that are right in fit, right in style and right in price. For every design pictured on this page we will furnish a pattern for ten cents. We have a liberal offer to make you in regard to these patterns. Here it is: We will give one Madison Square pattern if you send us only one new subscription to FARM AND FIRESIDE for eight months at the special price of twenty-five cents. The subscription must be for some one not now a subscriber to FARM AND FIRESIDE. Send orders to the Pattern Department, FARM AND FIRESIDE, 11 East 24th Street, New York City.

Follow these directions when ordering patterns: For ladies' waists, give bust measure in inches; for skirts, give waist measure in inches; for misses and children, give age. Don't fail to mention the number of the pattern you desire. Satisfaction guaranteed.

If you have not seen the new pattern catalogue of Madison Square patterns, you will find it to your interest to send for it. The price of this catalogue is ten cents. Order the catalogue from the Pattern Department.

Copyright, 1910, by The Crowell Publishing Company



Intense Black
There is one sure way to get the deepest fast black in cotton dress-goods of quality—
Simpson-Eddystone Solid Black Prints
have been the standard calicoes for over 65 years. Washing, sunlight or perspiration will not move the intense unchangeable lustrous color from these well-woven cloths.
If your dealer hasn't Simpson-Eddystone Prints write us his name. We'll help him supply you.
The Eddystone Mfg. Co., Philadelphia
Established by Wm. Simpson, Sr.

A big bowl of Quaker Oats

is the best dish you can serve.

Delicious and nourishing

Good for all ages and all conditions.

Economical and strengthening 58

AGENTS WANTED Men or Women to sell Consumers. Big Profits. Groceries, Coffees, Teas, Extracts, Perfumes, Soaps, etc. With or without premiums. Write for catalogue A. Bushway Flavoring Extract Co., 961 N. Water St., Decatur, Ill.

DAISY FLY KILLER placed anywhere, attracts and kills all flies. Neat, clean, ornamental, convenient, cheap. Lasts all season. Made of metal, cannot spill or tip over, will not soil or injure anything. Guaranteed effective. Of all dealers or sent prepaid for 20 cents. HAROLD SOMERS 150 DeKalb Ave. Brooklyn, N. Y.

A DOCTOR'S EXPERIENCE Medicine Not Needed in This Case

It is hard to convince some people that coffee does them an injury! They lay their bad feelings to almost every cause but the true and unsuspected one.

But the doctor knows. His wide experience has proven to him that, to some systems, coffee is an insidious poison that undermines the health.

Ask the doctor if coffee is the cause of constipation, stomach and nervous troubles.

"I have been a coffee drinker all my life. I am now 42 years old and when taken sick two years ago with nervous prostration, the doctor said that my nervous system was broken down and that I would have to give up coffee.

"I got so weak and shaky I could not work, and reading your advertisement of Postum, I asked my grocer if he had any of it. He said, 'Yes,' and that he used it in his family and it was all it claimed to be.

"So I quit coffee and commenced to use Postum steadily and found in about two weeks' time I could sleep soundly at night and get up in the morning feeling fresh. In about two months I began to gain flesh. I weighed only 146 pounds when I commenced on Postum and now I weigh 167 and feel better than I did at 20 years of age.

"I am working every day and sleep well at night. My two children were great coffee drinkers, but they have not drank any since Postum came into the house, and are far more healthy than they were before."

Read "The Road to Wellville," found in pkgs. "There's a Reason."

Ever read the above letter? A new one appears from time to time. They are genuine, true and full of human interest.

