



203990

3990





EDITED BY

**DIONYSIUS LARDNER, D.C.L.,**

Formerly Professor of Natural Philosophy and Astronomy in University College, London.

ILLUSTRATED BY ENGRAVINGS ON WOOD.

VOL. V.

LONDON:

**WALTON AND MABERLY,**

UPPER GOWER STREET AND IVY LANE, PATERNOSTER ROW.

1855.

LONDON  
BRADBURY AND EVANS, PRINTERS, WHITEFRIARS.

## CONTENTS.

### THE STEAM ENGINE.

	PAGE
CHAP. I.—1. The steam engine.—2. Consists of two essential parts.—3. The boiler.—4. Material employed in its formation.—5. Feeding apparatus.—6. Importance of keeping the water in the boiler at a proper level.—7. Wet and dry steam.—8. Priming.—9. Means of ascertaining the level of the water in the boiler.—10. Self-acting feeders.—11. Safety valve.—12. Steam gauge.—13. The furnace.—14. Proper mode of feeding the furnace.—15. Rarely observed.—16. Contrivance for supplying fuel . . . . .	1
CHAP. II.—17. Method of regulating the activity of the furnace.—18. How steam is made to produce a mechanical effect.—19. The cylinder and piston.—20. Metallic pistons.—21. Estimate of the force with which the piston is moved.—22. Transmission of this force.—23. Piston rod.—24. Cocks, valves, and slides.—25. How employed.—26. Stroke of the engine.—27. Effective pressure.—28. Supply of steam to the cylinder.—29. By valves.—30. By slides.—31. Seaward's slides.—32. Single cock.—33. Four-way cock.—34. Low and high pressure, more properly called condensing and non-condensing, engines.—35. Objections to the latter and countervailing advantages.—36. Condensing engines.—37. Condensing apparatus.—38. Air-pump.—39. Cold water pump.—40. Hot water pump . . . . .	17
CHAP. III.—41. Comparative merits of the two kinds of engines.—42. Various modes of transmitting force.—43. Description of a factory engine.—44. The governor.—45. The eccentric.—46. The fly-wheel.—47. Parallel motion.—48. Barometer gauge.—49. How to compute the effective moving force of the piston.—50. Method not considered sufficiently accurate.—51. Indicator.—52. Mode of recording its positions.—53. Its application in finding effective force.—54. Watt's counter.—55. Conclusion . . . . .	33

### THE EYE.

CHAP. I.—1. Pleasures and advantages of the power of vision.—2. Reasons why a knowledge of the structure and functions of the eye is desirable.—3. Description of the eye.—4. Sclerotica and	
--	--

	PAGE
cornea.—5. Aqueous humour, pupil, and iris.—6. Crystalline humour and ciliary processes.—7. Choroid.—8. Retina and vitreous humour.—9. Axis of the eye and optic nerve.—10. Numerical data.—11. Limits of the play of the eye.—12. Achromatism of the eye.—13-16. How vision is caused.—17. Conditions of perfect vision.—18. Distinctness of the image.—19. Parallel rays.—20, 21. Defects of vision and their remedies.—22-24. Power of adaptation.—25-29. Limits of this power.—30, 31.—Causes of defective vision.—32. Magnitude of the image on the retina.—33. Apparent magnitude defined.—34-37. Nature of its variation.—38-40. Diminutiveness of the pictures on the retina.—41. Sufficiency of illumination . . . . .	49
CHAP. II.—42. Power of accommodation of the eye.—43, 44. Apparent brightness of luminous objects.—45-47. Intensity of brightness.—48-57. The image must continue a sufficient time upon the retina to enable that membrane to produce a perception of it—Various illustrations of this.—58. Conditions which determine apparent motion.—59. How affected by distance.—60. Example.—61. When imperceptible.—62. Motion of the firmament.—63. Objects in rapid motion invisible.—64-66. Duration of the impression on the retina.—67. Optical toys.—68, 69. Coincidence of the optical and geometrical centres of the eye.—70. Ocular spectra and accidental colours.—71. Why visible objects do not appear inverted.—72. The seat of vision.—73-75. The optic nerve insensible to light . . . . .	65
CHAP. III.—76. Why objects are not seen double.—77. Exceptional cases.—78. The eye has no direct perception of distance or magnitude.—79. How distances are estimated.—80. Appearance of the sun and moon when rising or setting.—81. How magnitudes are estimated.—82. Illusion produced in St. Peter's at Rome.—83. Magnitude inferred from distance.—84. Perception of angular motion.—85. How real direction of motion may be inferred.—86. Examples of the sun and moon.—87-90. Effect of the motion of the observer—Examples.—91. Angular distance defined.—92. The eye has no direct perception of form—How inferred.—93. Visible area defined.—94. Figure inferred from lights and shadows.—95. Power of distinguishing colours.—96, 97. Absence of this power in particular cases . . . . .	81

### THE ATMOSPHERE.

1. Experimental proofs of the weight of the atmosphere.—2. The bladder glass.—3. Pressure equal in all directions.—4. Pressure of air in a room explained.—5. Magdeburg hemispheres.—6. Suction with tube.—7. Pascal's experiment at Rouen.—8. Horror of a vacuum.—9. Galileo and the pump-makers.—10. Torricelli's celebrated experiment.—11. Pascal's experiment on the Puy-de-dôme.—12. Actual pressure of atmosphere ascertained.—13. Height of an atmosphere of uniform density.—14. Vastly greater

	PAGE
height of an elastic atmosphere.—15. Air less and less dense in ascending.—16. Effects of atmospheric pressure.—17. Boy's plaything of a sucker.—18. Flies walking on ceiling.—19. Respiration.—20. Action of bellows.—21. Ventpeg—lid of tea-pot.—22. Pneumatic ink-bottle.—23. Syringes.—24. Exhausting syringe.—25. Rate of rarefaction.—26. Absolute vacuum cannot be obtained.—27. But may be indefinitely approached.—28. Air-pump.—29. Condensing syringe.—30. Condenser . . . . .	97

COMMON THINGS.—TIME.

<p>CHAP. I.—1. Simple notions difficult to define.—2. Conception of Time, how obtained.—3. By succession of sensible impressions.—4. Proof that such succession is necessary.—5. Time passes faster with some than with others.—6. Is measured only by a regular and uniform succession.—7. Periodic phenomena which may measure time.—8. Natural appearances intended for that purpose.—9. Significations of the word "day."—10. Hours.—11. Their length in certain cases variable.—12. Vulgar and equinoctial hours.—13. Commencement of the day with different nations.—14. Italian time.—15. Inconvenience of such a mode of reckoning.—16. Modern method.—17. Civil and astronomical time.—18. The day the standard unit.—19. Necessary to determine it rigorously.—20. What is a day?—21. Diurnal rotation of the heavens.—22. Its constancy and uniformity.—23. Nevertheless not fitted to be the unit of civil time.—24. The meridian.—25. Diurnal motion of the sun—means of observing it.—26. Transit instrument.—27. Method of observing with it.—28. Sidereal day—its subdivisions.—29. Its permanency and uniformity—unfit, nevertheless, for a measure of time.—30. Why the sun is not fit . . . . .</p>	113
--	-----

<p>CHAP. II.—31. How to observe the sun's transits.—32. Interval between them variable.—33. Mean and apparent time.—34. Relative changes of mean and apparent time.—35. The days on which they coincide.—36. The Equation of time.—37. Further explained.—38. Its extreme error.—39. Mean time adopted in France.—40. Unfitness of apparent time.—41. Local time varies with longitude.—42. Equalisation of local time proposed.—43. How time-pieces are regulated.—44. Mean solar hours, minutes, and seconds.—45. Length of sidereal day.—46. The week.—47. Opinions as to its origin.—48. Both opinions erroneous.—49. Origin of the names of the days.—50. First day of the week.—51. The month . . . . .</p>	129
---	-----

<p>CHAP. III.—The month (continued).—52. Not conformable with lunar periods.—53. Difficulty of subdividing the year.—54. Division unequal.—55. Egyptian months.—56. Greek.—57. Solon's months.—58. Roman months.—Romulus.—59. Origin of names of months.—60. Additional months of Numa.—61. Origin of their names.—62. Their lengths.—63. Superstition in favour of</p>	
---	--



	PAGE
odd numbers—methods of remembering the lengths of the months.—64. Calends.—65. Greek Calends.—66. Nones.—67. Ides.—68. Practice of counting backwards.—69. Discordance of the Roman year with the seasons.—70. Month Mercedonius.—71. Legal meaning of "month."—72. The year.—73. What is a year?—74. Egyptian.—75. Only a rude approximation to the course of the seasons.—76. The vague year and Sothic period.—77. Advantage of Egyptian year.—78. Greek year.—79. Meton and his cycle.—80. Origin of Golden Number.—81. Meton ridiculed by Aristophanes.—82. Near accordance of the lunar phases with the Metonic cycle.—83. Roman year.—84. Pontifical abuses.—85. Julian Calendar.—86. Bissextile years . . . . .	145
CHAP. IV.—87. Year of confusion.—88. New arrangement of the months.—89. Mistake of the Pontiffs.—90. Leap-years.—91. Historical dates.—92. Day of the equinox.—93. What is the equinox?—94. The two equinoctial points.—95. Sidereal year.—96. Precession of the equinoxes.—97. Equinoctial year.—98. Civil year.—99. Difference between it and the Julian year.—100. Effect of this difference.—101. Cause of the reformation of the Calendar.—102. Discordance between the real and ecclesiastical equinox.—103. Gregorian reform.—104. Gregorian Calendar.—105. Its compensating effect.—106. Resistance to its adoption.—107. Dates of its adoption in different countries.—108. In England.—109. Its reception there.—110. Occasional agreement of the new and old styles.—111. Anecdotes relating to the change.—112. Russia adheres to the old style.—113. Commencement of the year.—114. Various in different countries.—115. In England.—116. Old and new style in England.—117. Temporary inconvenience attending it . . . . .	161

#### COMMON THINGS.—PUMPS.

Earliest methods of raising water.—2. Bucket in a well.—3. By windlass and rope.—4. By two buckets balanced over a pulley.—5. Method of working these by animal power.—6. The rope in this case balances itself.—7. The lifting pump.—8. Double lifting pump worked by animal power.—9. Various forms of valves.—10. Clack valves.—11. Conical spindle valves.—12. Ball valves.—13. The suction pump.—14. Analysis of its action.—15. Forcing pump.—16. Same with air vessel.—17. Same with solid plunger.—18. Double action forcing pump.—19. Garden watering pumps.—20. Fire-engine.—21. Chain pump.—22. Drainage of mines . . . . .	177
--	-----

#### COMMON THINGS.—SPECTACLES.

1. Their general utility.—2. Should therefore be generally understood.—3. Vision.—4. Blindness.—5. Defective sight.—6. Long and short sight.—7. Remedy.—8. Spectacles.—9. Effect of convex lenses.—10. Of concave lenses.—11. Focal length of a lens.—12.

	PAGE
Varies with distance of object.—13. Peculiarities of vision in short sight explained,—14. In long sight.—15. The mounting of spectacles.—16. Periscopic spectacles.—17. Both eyes have not always the same power of vision.—18. Ophthalmometer.—19. Application in selecting glasses.—20. Curious defects of vision .	193

## THE KALEIDOSCOPE.

1. Origin of the name.—2. Structure of the instrument.—3. Its optical effect.—4. Varieties of its form.—5. Its occasional use in the arts.—6. Another optical toy depending on two reflections .	205
--	-----



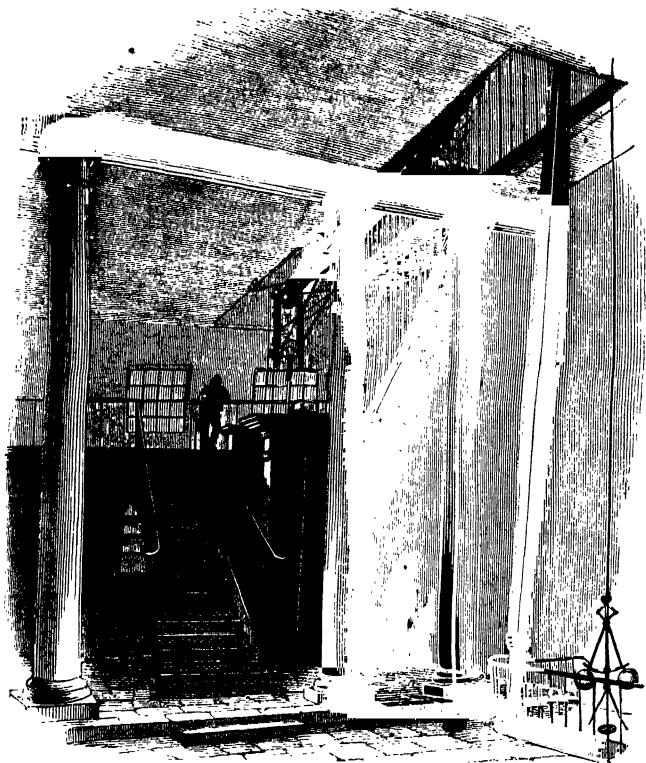

DOUBLE ACTING ENGINE, ZINC WORKS, CITY ROAD, LONDON.

## THE STEAM ENGINE.

### CHAPTER I.

1. The steam engine.—2. Consists of two essential parts.—3. The boiler.—4. Material employed in its formation.—5. Feeding apparatus.—6. Importance of keeping the water in the boiler at a proper level.—7. Wet and dry steam.—8. Priming.—9. Means of ascertaining the level of the water in the boiler.—10. Self-acting feeders.—11. Safety valve.—12. Steam gauge.—13. The furnace.—14. Proper mode of feeding the furnace.—15. Rarely observed.—16. Contrivance for supplying fuel.

## THE STEAM ENGINE.

1. WHEN the prodigious impetus given to civilisation all over the world, during the last hundred years, by the invention and improvement of the steam-engine is considered, and when it is observed that this, so far from being a temporary influence, is one that has constantly gone on, and still goes on with augmented and vastly accelerated energy,

*Mobilitate viget viresque acquirit eundo,*

it cannot be matter of surprise, that every one endowed with the most moderate gifts of sense and intelligence, whatever may be his position on the social scale, is animated with a strong desire to obtain some knowledge of the extraordinary machine by which results of such vast, enduring, and wide-spread importance have been attained.

Though comparatively few have the time, the inclination, or the peculiar intellectual aptitude to follow out the details of the mechanism of this great invention, as developed in its numerous applications to the various arts of life, all who are by circumstances and education raised above the condition of the rudest and most unskilled labourer have both the time and the mental qualifications to acquire a general acquaintance with the machine, and with the physical principles from which it derives its power. To this large class we now address ourselves, and propose to present them in a very brief compass with a general view of the principle and mechanism of the steam-engine, confining ourselves chiefly to those broad and general features which are common to all varieties of the machine, and discarding for the present such minute details of the mechanism as are applied only in particular forms of steam-engine, and which, though often admirable for ingenuity of design and contrivance, are nevertheless subordinate in interest when brought beside the larger and more general views we now refer to.

2. The steam-engine, whatever be its form or purpose, consists of two essentially different parts; the first, that in which the steam is generated, and the second, that in which the steam is worked. Although these taken together are essential to the performance of the machine, the name steam-engine in its strictest sense would signify only the latter, the former being called the boiler.

3. Boilers vary much in magnitude, form, structure, and even in material, according to the purpose to which they are applied, and the circumstances under which they are used. There are, however, certain characters common to all.

Every boiler consists of a reservoir for the water and steam, and a furnace with its appendages for the combustion of the fuel, the heat evolved from which is the physical agency by which the

## THE BOILER.

evaporation is produced and maintained. The boiler is formed of plates of metal, of suitable thickness, rivetted together, so as to be steam-tight, that is to say, so that steam cannot be forced between them.

The manner in which the plates are rivetted together is shown in fig. 1, the edges of the plates being laid one upon the other and their surfaces forced into steam-tight contact by rivets  $r r'$  passing through holes punched in them, the heads of the rivets being formed by the hammer while the iron is still soft by heat.

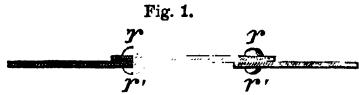

The appearance of the rows of rivets along the edges of the plates composing the boiler is shown in the general view of a waggon-boiler in fig. 7.

4. The material of the boiler is most commonly wrought iron. Copper is sometimes though very rarely used. It has an advantage over iron, inasmuch as it is a better conductor of heat, and is less liable to become incrustated by lime and other earthy matter, which is always held in solution by the water, and precipitated in the process of evaporation. It is also more durable than iron, but is excluded, save in rare and exceptional cases, because of its greater cost.

Cast iron, though cheaper than wrought iron, would be inadmissible for several reasons, one of which is its brittleness. If explosion happened it would fly in pieces, the fragments becoming destructive missiles. In case of explosion wrought iron would be ripped and torn. The one is tough, the other brittle.

5. The boiler is a reservoir not only for water but for steam. The steam, being much lighter, bulk for bulk, than water will always ascend in bubbles through the water, and will collect in the upper parts of the boiler. The space within the boiler, therefore, may be conceived to be divided at a certain level between the water and the steam. All the space below that level is appropriated to the water, all above it to the steam.

But according as the water is converted into steam, the quantity contained in the boiler being proportionally diminished, this level would fall continually lower and lower. That, however, is prevented by a FEEDING APPARATUS, which generally consists of forcing pumps, of adequate power, by which as much water is driven into the boiler as is converted into steam by the furnaces. This feeding apparatus is, in some cases, worked only from time to time to replenish the boiler, in other cases the supply is continual. In the former case, the level which separates the steam from the water alternately rises and falls within certain limits.

## THE STEAM ENGINE.

While the action of the feeding apparatus is suspended it falls gradually as the evaporation proceeds. When it has descended to a certain point the feeding apparatus is put in action and the level rises again to its former limit, after which it is again suspended, and so on. This rise and fall of the level of the water in the boiler is, or ought to be, restrained between such limits, that the level is never either injuriously high or injuriously low.

When the feeding apparatus works incessantly, the water in the boiler is kept always at the same level, the arrangements being such that by a self-adjusting mechanism, the quantity of water supplied to the boiler, from minute to minute, is exactly equal to the quantity evaporated.

6. The importance of keeping the boiler duly supplied with water will be easily understood. So long as those parts of the boiler which are exposed to the action of the furnace are filled with water the metal can never become unduly heated, because all the heat imparted by the furnace is absorbed by the water in evaporation. But if the level of the water were allowed to subside below any part which is exposed to the action of the furnace, the heat acting upon such parts not being taken up by the water, and the steam which in that case would alone be in contact with them, being a slow recipient of heat, the plates of the boiler would soon become red hot, and would consequently be softened, so as no longer to possess the strength necessary to resist the pressure within them, and the boiler would burst. For this reason, it is always of the utmost importance to provide means to ensure such a supply of water as shall prevent the level from ever falling below the highest parts upon which the furnace acts.

Inconvenience of a different kind would be produced by over-feeding, and consequently by raising the level of the water above a certain limit. When the water in a boiler is in a state of strong ebullition, which it always is in the boilers of engines in full operation, bubbles of steam are produced in great quantities in the lowest parts, these being the parts upon which the action of the furnace is most energetic. These bubbles, rising with violence to the surface, throw up the water in spray, so that the part of the boiler above the level of the water is filled with a mixture of pure steam and of particles of water in minute subdivision. The latter, however, fall back into the water by their gravity, provided that the space left for the steam have sufficient height. The upper part of that space will then be supplied with pure steam without intermixture with spray. But if the boiler be over-filled with water, so that the space left for the steam have so little height that more or less spray is mixed even with the highest parts of it, this spray will be drawn into the working part of the

## PRIMING—GAUGE-COCKS.

machine, and will be attended with the two-fold evil of injuring the performance of the engine and wasting a quantity of heat which would otherwise be employed in producing steam, and therefore producing mechanical power.

7. Nevertheless with all practicable precautions spray sometimes issues with the steam from the boiler to the engine. Steam, in this condition, is like the air when a fine misty rain floats in it, and is called **WET STEAM** by the engineers; the steam when free from this defect being called **DRY STEAM**. A handkerchief held in dry steam issuing from the valve of a boiler will be no more damped than it would be by a blast of wind; but if the steam be charged more or less with spray, its presence will be shown at once by the moisture it would deposit.

8. The spray with which wet steam is charged is called by the engineers **PRIMING**.

9. It appears, therefore, that whatever be the form of the machine, or the purpose to which it is applied, it is of great importance so to regulate the feed of the boiler, that the level of the water in it shall neither fall too low nor rise too high.

Considering then the great importance of keeping the level of the water in the boiler within the limits here defined, it will be evident that some expedient ought to be provided by means of which the engineman can at all times ascertain what the level of the water actually is.

Different methods, all more or less efficient and ingenious, have been invented for accomplishing this object.

One of the most simple consists in two common cocks, called gauge cocks, like those used in a beer barrel, which are inserted in the side or end of the boiler, one of which is placed at the lowest, and the other at the highest limit of the water level. If the engineman, on opening the latter, finds that water issues from it, he knows that the level has risen to its highest limit, and he suspends the feed. If, on opening the former, he finds the steam issue from it, he knows that the water level has fallen too low, and he lays on the feed. But so long as water issues from the one and steam from the other, he knows that the water level is within the required limits.

This method, though generally adopted, is not exclusively depended on, and others are used.

A weight  $F$  (fig. 2), half immersed in the water, is supported by a wire, which, passing steam-tight through a small hole in the top, is connected by a flexible string or chain, passing over a wheel  $w$ , with a counterpoise  $A$ , just sufficient to balance  $F$  when half immersed. If  $F$  be raised above the water,  $A$  being lighter will no longer balance it, and  $F$  will descend pulling up  $A$ , and



## THE STEAM ENGINE.

turning the wheel *w*. If *F* be plunged deeper in the water, *A* will more than balance it, and will pull it up, so that the only position

Fig. 2.

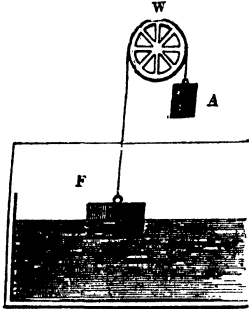

in which *F* and *A* will balance each other is, when *F* is half immersed. The wheel *w* is so adjusted, that when two pins placed on its rim are in the horizontal position, the water is at its proper level. Consequently it follows, that if the water rise above this level, the weight *F* is lifted and *A* falls, so that the pins come into another position, and if it fall lower, *F* falls and *A* rises, so that the pins assume a different position. Thus, in general, the position of the pins becomes an

indication of the quantity of water in the boiler.

Another method is to place a glass tube (fig. 3), with one end *T* entering the boiler above the proper level, and the other end *T'* entering it below the proper level. It must be evident that the water in the tube will always stand at the same level as the water in the boiler, since the lower part has a free communication with that water, while the surface is submitted to the pressure of the same steam as the water in the boiler.

Fig. 3.

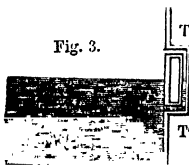

This and the last-mentioned gauge have the advantage of addressing the eye of the engineer at once, without any adjustment; whereas the gauge-cocks must be both opened, whenever the depth is to be ascertained.

These gauges, however, require the constant attention of the engine-man; and it becomes desirable either to find some more effectual means of awakening that attention, or to render the supply of the boiler independent of any attention. In order to enforce the attention of the engineman to replenish the boiler when partially exhausted by evaporation, a tube was sometimes inserted at the lowest level to which it was intended that the water should be permitted to fall. This tube was conducted from the boiler into the engine-house, where it terminated in a mouth-piece or whistle, so that whenever the water fell below the level at which this tube was inserted in the boiler, the steam would rush through it, and issuing with great velocity at the mouth-piece, would summon the engineer to his duty with a call that would rouse him even from sleep.

## SELF-ACTING FEEDER.

In the most effectual of these methods, the task of replenishing the boiler must still be executed by the engineer; and the utmost that the boiler itself was made to do, was to give due notice of the necessity for the supply of water. The consequence was, among other inconveniences, that the level of the water was subject to constant variation.

10. To remedy this a method has been invented, by which the engine is made to feed its own boiler. The pipe *g* (fig. 4), which leads from the hot water pump, terminates in a small cistern *c* in which the water is received. In the bottom of this cistern, a valve *v* is placed, which opens upwards and communicates with a feed pipe, which descends into the boiler below the level of the water in it. The stem of the valve *v* is connected with a lever turning on the centre *D*, and loaded with a weight *F* dipped in the water in the boiler in a manner similar to that described in fig. 2, and balanced by a counterpoise *A* in exactly the same way. When the level of the water in the boiler falls, the float *F* falls with it, and pulling down the arm of the lever raises the valve *v*, and lets the water descend into the boiler from the cistern *c*. When the boiler has thus been replenished, and the level raised to its former place, *F* will again be raised, and the valve *v* closed by the weight *A*. In practice, however, the valve *v* adjusts itself by means of the effect of the water on the weight *F*, so as to permit the water from the feeding cistern *c* to flow in a continued stream, just sufficient in quantity to supply the consumption from evaporation, and to maintain the level of the water in the boiler constantly the same.

By this arrangement the boiler is made to replenish itself; or, more properly speaking, it is made to receive such a supply, as that it never wants replenishing—an effect which no effort of attention on the part of an engineman could produce. But this is not the only good effect produced by this contrivance. A part of the steam which originally left the boiler, having discharged its duty in moving the engine, is lodged in the hot well *c* (fig. 4), and is again restored to the source from which it came, bringing back to the boiler all the unconsumed portion

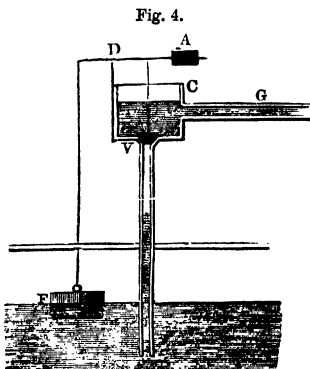

## THE STEAM ENGINE.

of its heat preparatory to being once more put in circulation through the machine.

Another method of arranging a self-regulating feeder is shown in fig. 5. A is a hollow ball of metal attached to the end of a lever, whose fulcrum is at B. The other arm of the lever C is connected with the stem of a spindle valve, communicating with a

Fig. 5.

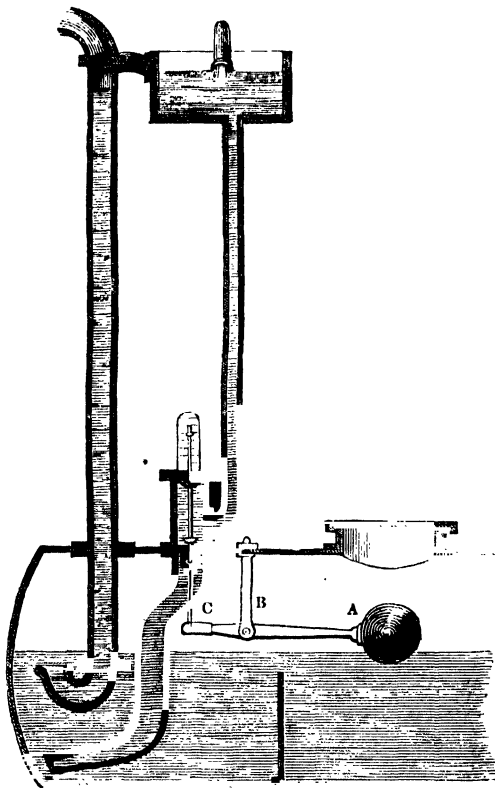

tube which receives water from the feeding cistern. Thus, when the level of the water in the boiler subsides, the ball A preponderating over the weight of the opposite arm, the lever falls, the arm C rises and opens the valve, and admits the feeding water.

## SAFETY VALVE.

This apparatus will evidently act in the same manner and on the same principles as that already described.

11. In different applications of the engine, steam of different pressure is required. The pressure of steam is usually expressed by stating the number of pounds weight upon each square inch of surface which would exactly resist or balance it. All boilers are provided with a valve which opens outwards, and which is loaded with a certain limited and regulated weight. When the bursting pressure with which the steam urges this valve exceeds the weight with which it is loaded, the valve yields, is opened, and the steam escapes through it, and thus continues to escape until the quantity pent up in the boiler is so diminished, that its pressure upon the valve no longer exceeds the weight with which the valve is loaded. When this happens, the valve will remain closed, but will be ready to yield and to open upon the least increase of the pressure of the steam.

Such a valve is called a "safety valve" for the obvious reason that it prevents the pressure of the steam in the boiler from ever attaining such a force as would endanger the boiler.

It sometimes happens that it is necessary to vary from time to time the pressure of the steam according to the work to which the engine is applied, and consequently to vary the weight upon the safety valve. In such cases it is usual to provide two safety valves, one of which shall be regulated by the engineer, and the other placed out of his power. The latter in that case is loaded with the greatest pressure which the boiler can bear without danger; so that even though the engineer should indiscreetly load the valve left at his disposition beyond the limit of safety, the other valve would yield the moment the steam attained a dangerous pressure.

Safety valves are of numerous forms. They consist usually of a circular aperture cut in the boiler, with conical edges inclining from within outwards. In this is placed a circular plate or stopper of corresponding size, with corresponding conical edges, so that it shall exactly fit the aperture; and when pressed upon it, the conical edges shall be in steam-tight contact. This circular plate is attached at its centre to an iron rod, which rises perpendicular to it. Upon this rod sliding weights are placed so as to press down the valve with a greater or less force, according as their number is increased or diminished.

In the general view of a boiler of the form called waggon boiler, shown in fig. 7, the safety valve is shown at N. It is provided with a handle, by means of which the engineman can raise it when necessary.

12. It is necessary to provide a ready method of indicating at all

## THE STEAM ENGINE.

times the actual pressure of the steam in the boiler. Various methods are used for this purpose. In boilers where steam of great pressure is used, the pressure is indicated by a spring gauge, similar in its principle to those used for steel yards to weigh bodies in commerce. The pressure of the steam acts against a valve which is connected with the arm of the lever of the steel-yard, the other arm being connected with the spring. In this way the varying tension of the spring is made to measure the pressure on the valve.

When steam of low pressure is used, an expedient called a mercurial steam gauge is used. A bent tube containing mercury is inserted into some part of the apparatus, which has free communication with the steam.

Fig. 6.

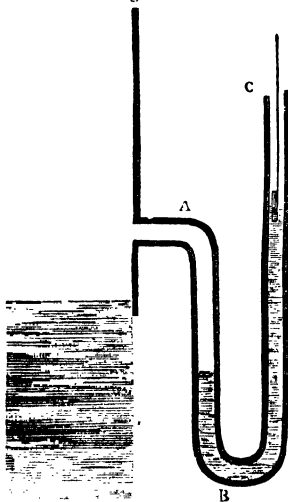

Let A B C (fig. 6), be such a tube. The pressure of the steam forces the mercury down in the leg A B, and up in the leg B C. If the mercury in both legs be at exactly the same level, the pressure of the steam must be exactly equal to that of the atmosphere; because the steam pressure on the mercury in A B balances the atmospheric pressure on the mercury in B C. If, however, the level of the mercury in B C be above the level of the mercury in B A, the pressure of the steam will exceed that of the atmosphere. The excess of its pressure above that of the atmosphere may be found by observing the difference of the level of the mercury in the tubes B C and B A, allowing a pressure of one pound on each square

inch for every two inches in the difference of the levels.

If, on the contrary, the level of the mercury in B C should fall below its level in A B, the atmospheric pressure will exceed that of the steam, and the quantity of the excess may be ascertained exactly in the same way.

If the tube be glass, the difference of levels of the mercury would be visible; but it is most commonly made of iron; and, in order to ascertain the level, a thin wooden rod with a float is inserted in the open end of B C, so that the portion of the stick within the tube indicates the depth of the level of the mercury below its mouth.

## STEAM GAUGE—FURNACE.

13. The most important appendage of the boiler is the furnace, which consists of a grate, upon which the fuel is maintained in combustion,—a system of flues, by which the flame and heated gases proceeding from the fuel in combustion are conducted in contact with the boiler, so as to impart more or less of their heat to the boiler, and, in fine, a chimney by which these gases escape into the atmosphere, and which maintains the draft necessary to give effect to the combustion.

The explanation of the furnace and its appendages, as well as that of the boiler already given, will be rendered much more easily intelligible by the aid of the figures 7, 8, 9, and 10, which, though they represent a particular form of boiler, indicate those provisions and arrangements which are most generally used in boilers of all forms.

The form here represented is called the waggon-boiler, and consists of a semi-cylindrical top, flat perpendicular sides, flat ends, and a slightly concave bottom. The steam intended to be used in boilers of this description does not exceed the pressure of the external atmosphere by more than from 3 to 5lbs. per square inch; and the flat sides and ends, though unfavourable to strength, can be constructed sufficiently strong for this purpose. In a boiler of this sort, the air and smoke passing through the flues that are carried round it, are in contact at one side only with the boiler. The brickwork, or other materials forming the flue, must therefore be non-conductors of heat, that they may not absorb any considerable portion of heat from the air passing in contact with them.

A perspective view of the boiler and furnace is presented in fig. 7. The grate and a part of the flues are rendered visible by the removal of a portion of the surrounding masonry in which the boiler is set. The interior of the boiler is also shown by cutting off one half of the semi-cylindrical roof. A longitudinal vertical section is shown in fig. 8, and a cross section in fig. 9. A horizontal section taken above the level of the grate, and below the level of the water in the boiler, shewing the course of the flues, is given in fig. 10. The corresponding parts in all the figures are marked by the same letters.

14. The door by which fuel is introduced upon the grate is represented at A, and the door leading to the ash-pit at B. The fire bars at C slope downwards from the front at an angle of about  $25^{\circ}$ , giving a tendency to the fuel to move from the front towards the back of the grate. The ash-pit D is constructed of such a magnitude, form, and depth, as to admit a current of atmospheric air to the grate-bars, sufficient to sustain the combustion. The form of the ash-pit is usually wide below, contracting towards the top.

## THE STEAM ENGINE.

The fuel, when introduced at the fire-door A, should be laid on that part of the grate nearest to the fire-door, called the dead plates: there it is submitted to the process of coking, by which the gases and volatile matter which it contains are expelled, and

Fig. 7.

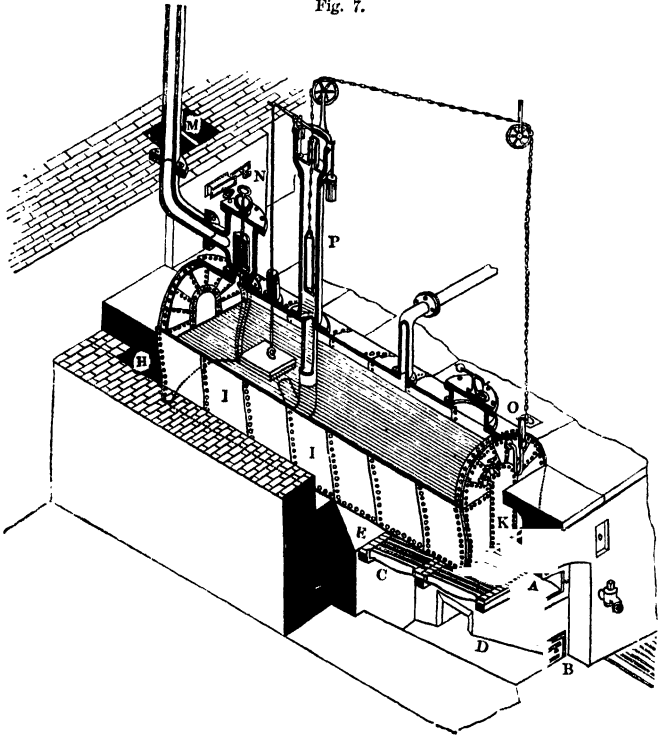

being carried by a current of air admitted through small apertures in the fire-door over the burning fuel in the hinder part of the grate, they are burnt. When the fuel in front of the grate has been thus *coked*, it is pushed back, and a fresh feed introduced in front. The coal thus pushed back soon becomes vividly ignited, and by continuing this process, the fuel spread over the grate is maintained in the most active state of combustion at the hinder part of the grate. By such an arrangement, the smoke produced by the combustion of the fuel may be burnt before it enters the

## FURNACE AND ITS APPENDAGES.

flues. The flame and heated air proceeding from the burning fuel arising from the grate, and rushing towards the back of the furnace, passes over the *fire-bridge* E, and is carried through the flue F which passes under the boiler. This flue (the cross section of which is shown in fig. 9, by the dark shade put under the boiler), is very nearly equal in width to the bottom of the boiler, the space at the bottom of the boiler, near the corners, being only what is sufficient to give the weight of the boiler support on the

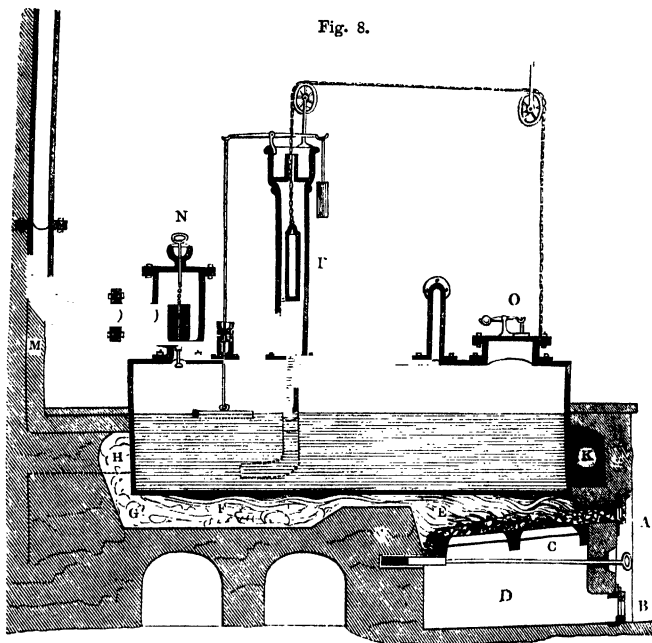

masonry forming the sides of the flue. The bottom of the boiler being concave, the flame and heated air as they pass along the flue rise to the upper part by the effects of their high temperature, and *lick* the bottom of the boiler from the fire-bridge *a* E to the further end G.

At G the flue rises to H, and turning to the side of the boiler at I I, conducts the flame in contact with the side from the back to the front; it then passes through the flue K across the front, and returns to the back by the other side flue L. The side flue is represented, stripped of the masonry, in fig. 7, and also appears in



## THE STEAM ENGINE.

the plan in fig. 10, and in the cross section in fig. 9. The course of the air is represented in fig. 10 by the arrows. From the flue *L* the air is conducted into the chimney at *M*.

By such an arrangement, the flame and heated air proceeding from the grate are made to circulate round the boiler, and the length and magnitude of the flues through which they are conducted should be such, that when they arrive at the chimney their temperature shall be reduced, as nearly as is consistent with the maintenance of draught in the chimney, to the temperature of the water.

15. The method of feeding the furnace, which has been described above, is one which, if conducted with skill and care, would pro-

Fig. 9.

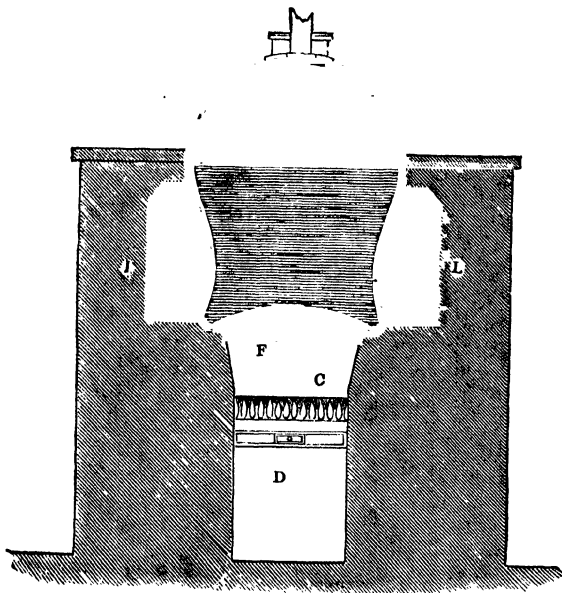

duce a much more perfect combustion of the fuel than would attend the common method of filling the grate from the back to the front with fresh fuel, whenever the furnace is fed. This method, however, is rarely observed in the management of the furnace. It requires the constant attention of the stokers (such is the name given to those who feed the furnaces). The fuel must

## FURNACE AND ITS APPENDAGES.

be supplied, not in large quantities, and at distant intervals, but in small quantities and more frequently. On the other hand, the more common practice is to allow the fuel on the grate to be in a great degree burned away, and then to heap on a large quantity of fresh fuel, covering over with it the burning fuel from the

Fig. 10.

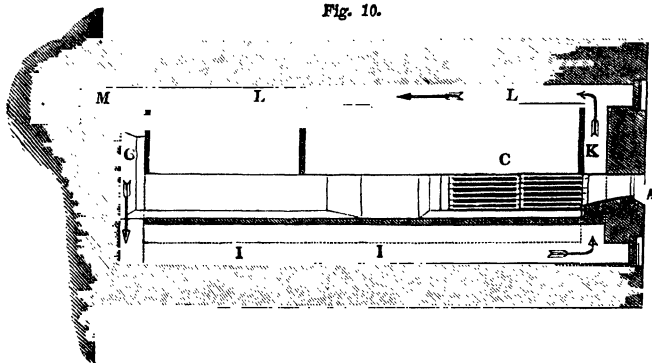

back to the front of the grate. When this is done, the heat of the ignited coal acting upon the fresh fuel introduced, expels the gases combined with it, and, mixed with these, a quantity of carbon, in a state of minute division, forming an opaque black smoke. This is carried through the flues and drawn up the chimney. The consequence is, that not only a quantity of solid fuel is sent out of the chimney unconsumed, but the hydrogen and other gases also escape unburned, and a proportional waste of the combustible is produced; besides which, the nuisance of an atmosphere filled with smoke ensues. Such effects are visible to all who observe the chimneys of steam vessels, while the engine is in operation. When the furnaces are thus filled with fresh fuel, a large volume of dense black smoke is observed to issue from the chimney. This gradually subsides as the fuel on the grate is ignited, and does not reappear until a fresh feed is introduced.

16. The former method of feeding, by which the furnace would be made to consume its own smoke, and the combustion of the fuel be rendered complete, is not however free from counteracting effects. In ordinary furnaces the feed can only be introduced by opening the fire-doors, and during the time the fire-doors are opened a volume of cold air rushes in, which passing through the furnace is carried through the flues to the chimney. Such is the effect of this in lowering the temperature of the flues, that in many cases the loss of heat occasioned is greater than any economy

## THE STEAM ENGINE.

of fuel obtained by the complete consumption of smoke. Various methods, however, may be adopted by which fuel may be supplied to the grate without opening the fire-doors, and without disturbing the supply of air to the fire. A hopper built into the front of the furnace, with a moveable bottom or valve, by which coals may be allowed to drop in from time to time upon the front of the grate, would accomplish this.

In order to secure the combustion of the gases evolved from the coals placed in the front of the grate, it is necessary that a supply of atmospheric air should be admitted with them over the burning fuel. This is effected by small apertures or regulators, provided in the fire-doors, governed by sliding plates, by which they may be opened or closed to any required extent.

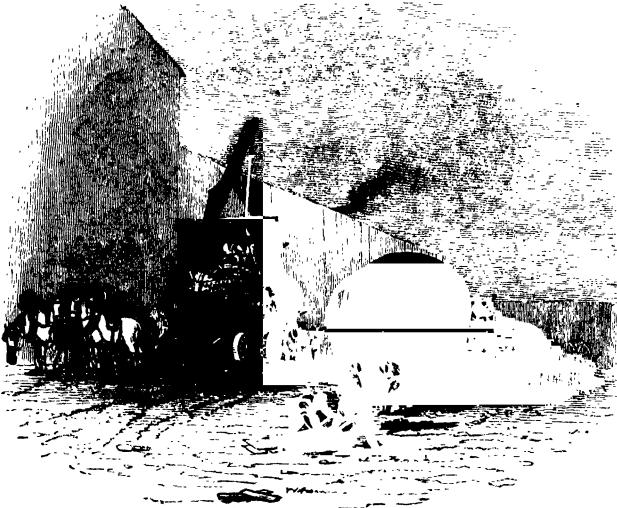

BOILER MANUFACTORY.

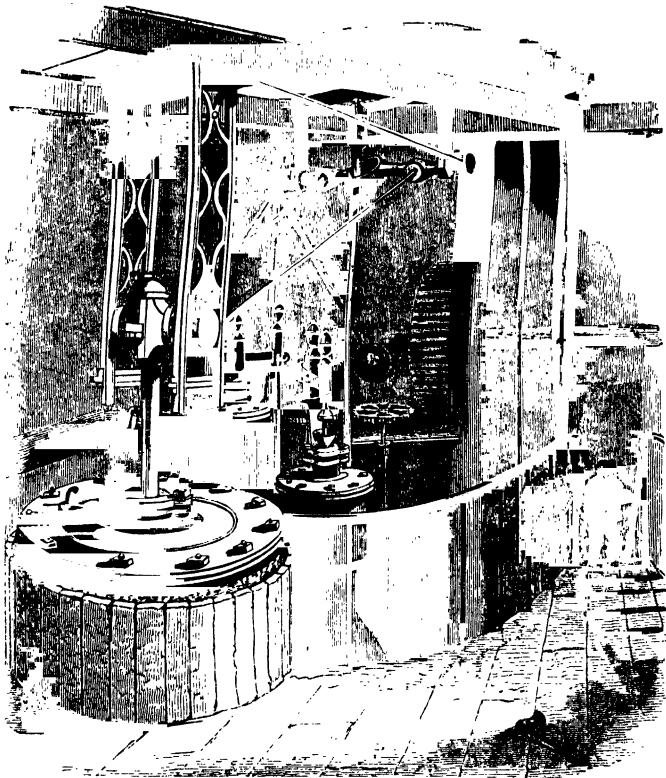

DOUBLE-ACTING ENGINE—CITY SAW-MILLS.

## THE STEAM ENGINE.

### CHAPTER II.

17. Method of regulating the activity of the furnace.—18. How steam is made to produce a mechanical effect.—19. The cylinder and piston.—20. Metallic pistons.—21. Estimate of the force with which the piston is moved.—22. Transmission of this force.—23. Piston rod.—24. Cocks, valves, and slides.—25. How employed.—26. Stroke of the engine.—27. Effective pressure.—28. Supply of steam to the cylinder.—29. By valves.—30. By slides.—31. Seaward's slides.—32. Single cock.—33. Four-way cock.—34. Low and high pressure, more properly called condensing and non-condensing, engines.—35. Objections

## THE STEAM ENGINE.

to the latter and countervailing advantages.—36. Condensing engines.—37. Condensing apparatus.—38. Air-pump.—39. Cold water pump.—40. Hot water pump.

17. **WHATEVER** be the form of boiler used, its magnitude and proportions, as well as those of the furnaces and their appendages, must be determined by the rate at which the steam is required to be produced, and in some degree also by the quality of the fuel.

The principle upon which a chimney more or less lofty produces a draft through the fuel in a fire-place in connection with it, has been already explained in our Tract on "Fire." The chimney connected with the furnace of a steam-boiler acts on the same principle, and its dimensions and height must necessarily be proportionate to those of the furnace, and to the quantity of fuel to be consumed in a given time.

But since the evaporation produced in the boiler requires to be varied with the varying work exacted from the engine; and since this evaporation will necessarily be proportionate to the rate at which the fuel is consumed in the furnace, it follows that the rate of combustion in the furnace should be varied with the varying power to be exacted from the engine. In order, therefore, to maintain this proportion between the force of the furnace and the demands upon the engine, it is necessary to stimulate or mitigate the furnace, as the evaporation is to be augmented or diminished.

The activity of the furnace must depend on the current of air which is drawn through the grate bars, and this will depend on the magnitude of the space afforded for the passage of that current through the flues. A plate called a *damp*er is accordingly placed with its plane at right angles to the flue, so that by raising and lowering it in the same manner as the sash of a window is raised or lowered, the space allowed for the passage of air through the flue may be regulated. This plate might be regulated by the hand, so that by raising or lowering it the draught might be increased or diminished, and a corresponding effect produced on the evaporation in the boiler: but the force of the fire is rendered uniformly proportional to the rate of evaporation by the following arrangement, without the intervention of the engineer. The column of water sustained in the feed pipe (figs. 7, 8), represents by its weight the difference between the pressure of steam within the boiler and that of the atmosphere. If the engine consumes steam faster than the boiler produces it, the steam contained in the boiler acquires a diminished pressure, and consequently the column of water in the feed pipe will fall. If, on the other hand, the boiler produce steam faster than the engine consumes it, the accumulation of steam in the boiler will cause an increased pressure on the water it contains, and thereby increase the height

## SELF-REGULATING DAMPER.

of the column of water sustained in the feed pipe. This column, therefore, necessarily rises and falls with every variation in the rate of evaporation in the boiler. A hollow float *r* is placed upon the surface of the water of this column; a chain connected with this float is carried upwards, and passed over two pulleys, after which it is carried downwards through an aperture leading to the flue which passes beside the boiler: to this chain is attached the damper. By such an arrangement it is evident that the damper will rise when the float *r* falls, and will fall when the float *r* rises, since the weight of the damper is so adjusted, that it will only balance the float *r* when the latter rests on the surface of the water.

Whenever the evaporation of the boiler is insufficient, it is evident from what has been stated, that the float *r* will fall and the damper will rise, and will afford a greater passage for air through the flue. This will stimulate the furnace, will augment its heating power, and will therefore increase the rate of evaporation in the boiler. If, on the other hand, the production of steam in the boiler be more than is requisite for the supply of the engine, the float will be raised and the damper let down, so as to contract the flue, to diminish the draught, to mitigate the fire, and therefore to check the evaporation. In this way the excess, or defect, of evaporation in the boiler is made to act upon the fire, so as to render the heat proceeding from the combustion as nearly as possible proportional to the wants of the engine.

18. Having thus explained generally the principal expedients by which the efficiency of the boiler and furnace of a steam-engine is maintained, it will be only necessary to add, that although these expedients, in the forms in which they are represented in the diagrams, will not be found in every steam boiler, yet equivalents to them in other forms or positions are almost universal. In certain cases the self-regulating apparatus of the boiler and furnace are excluded by want of the necessary height, and then the proper regulation of the machine must depend on the skill and vigilance of those who are in charge of it.

Supposing, then, that by these or other similar or equivalent provisions a supply of steam in the necessary quantity and of the requisite pressure is obtained, it remains to show how the steam is made to produce the desired mechanical effect.

The method universally adopted to render the power of steam available for mechanical purposes is that of a solid piston moving freely in a hollow cylinder in steam-tight contact with its sides. The steam is admitted alternately at one end and at the other, of the cylinder. When it is let in at either end, it is permitted to escape by the other, so that the piston is blown by the steam alternately from end to end of the cylinder. The ends of the

## THE STEAM ENGINE.

cylinder are closed by steam-tight covers, but proper openings are provided for the alternate admission and escape of the steam.

19. The cylinder is made of cast iron of adequate thickness and strength. It is bored with the nicest precision, so that its inner surface is truly cylindrical and of uniform diameter from end to end. The piston is also made of iron, and its contact with the cylinder is rendered steam-tight, either by a packing of hemp and soft rope, called gasket, which fills a circular groove or channel surrounding the piston, or by constructing the external rim of the piston of several metallic segments, which are urged against the side of the cylinder by springs which act upon them from the centre of the piston.

A section of a packed piston is given in fig. 11. The hollow

Fig. 11.

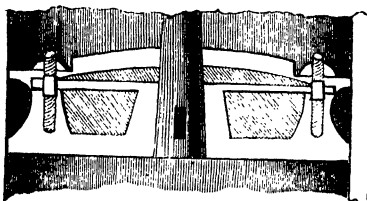

groove containing the packing is represented at the sides next the cylinder, and the top is attached to the piston by screws, by turning which the packing is compressed so as to be forced outwards against the sides of the cylinder

until it is in steam-tight contact with them.

20. Pistons which maintain steam-tight contact with the cylinder without packing, and which are called metallic pistons,

Fig. 12.

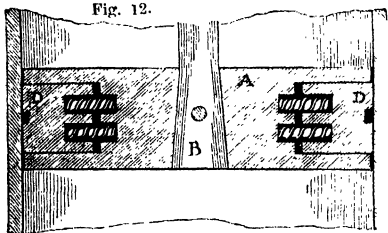

are of very various construction, though all of essentially the same principle. One of these is represented in section in fig. 12, and in plan in fig. 13, p. 21. A deep groove, square in its section, is formed around the piston,

so that while the top and bottom form circles equal in magnitude to that of the cylinder, the intermediate part of the body forms a circle less than the former by the depth of the groove. Let a ring of brass, cast iron, or cast steel, be made to correspond in magnitude and form with this groove, and let it be divided, as represented in fig. 13, into four segments *c c c c*, and four corresponding angular pieces, *D D D D*. Let the groove which surrounds the piston be filled by the four segments with the four wedge-like angular pieces within them, and let the latter be urged against the former by eight spiral springs, as represented

## PISTONS.

in fig. 12 and fig. 13. These springs will abut against the solid centre of the piston, and will urge the segments *c* against the cylinder. The spiral springs which urge the wedges are confined in their action by steel pins which pass through their centre, and by being confined in cylindrical cavities worked into the wedges and into corresponding parts of the solid centre of the piston, as the segments *c* wear, the springs urge the wedges outwards, and the points of the latter protruding, are gradually worn down so as to fill up the spaces left between the segments, and thus to complete the outer surface of the piston.

21. The force with which the piston is moved from end to end of the cylinder is estimated by the pressure of the steam which acts upon it, diminished by the reaction of the steam escaping from the side towards which it moves, and the resistance produced by its friction against the sides of the cylinder.

22. The mechanical force with which the piston is thus moved would be practically useless unless an expedient were provided by which it could be transmitted to some convenient point outside the cylinder, and since it is essential that the steam which impels the piston shall be confined within the cylinder, and that no air be allowed to enter, so as to react on the other side of the piston by its pressure, it is also essential that whatever be the means of transmitting the force of the piston to the outside of the cylinder, it shall be accomplished without leaving any interstitial space through which steam can escape or air enter.

23. This object is perfectly attained by a very simple contrivance. A hole is made through the centre of the piston, in which a truly formed cylindrical iron rod, called the piston-rod, is inserted and firmly fixed by a key or linch-pin. This piston-rod passes through a hole made in the iron cover of the cylinder, as shown in fig. 14. The piston-rod is kept in steam-tight contact with the edges of the hole by a contrivance called a *stuffing box*, *B*, represented in fig. 14. The hole made in the cover of the cylinder is very little greater in magnitude than

Fig. 13.

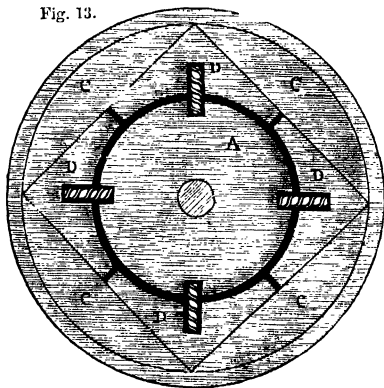



## THE STEAM ENGINE.

the diameter of the piston rod. Above this hole is a cup, in which, around the piston, is placed a stuffing of hemp or tow, which is saturated with oil or melted tallow. This collar of

Fig. 14.

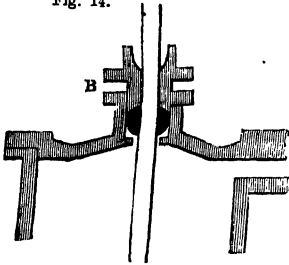

hemp is pressed down by another piece, also perforated with a hole through which the piston rod plays, and which is screwed down on the said collar of hemp.

The piston-rod, by this contrivance, being moved with the same alternate motion, and the same force as the piston itself, can be made to impart that force to any suitable piece of mechanism outside the cylinder, with

which it may be put in connection.

24. Since the ends of the cylinder are closed by metallic covers, in the manner explained above, the openings for the exit and entrance of the steam at the ends, are placed, not in the covers, but in the sides, at points in immediate contiguity with the covers. These openings are governed by contrivances of various forms, and variously denominated COCKS, VALVES, and SLIDES.

25. Let two openings be imagined to be provided at each end of the cylinder, one leading from the boiler, and the other for the escape of the steam. Let stop-cocks, or valves, or sliding shutters, be adapted to these openings, so that they can be closed or opened by acting upon the handles of the cock valve or slide, and let these handles be supposed to be put in such connection with the piston-rod that when the piston arrives at either end of the cylinder the handles are driven by the rod, so as to open the passage which admits steam to the end of the cylinder at which the piston has arrived, and to close the passage which is provided for its escape, and, on the contrary, to open the passage for the escape of the steam from the other end of the cylinder, and to close the passage for its admission from the boiler. By this means the piston, being acted upon by the steam at the end at which it has arrived, and, being relieved from the action of the steam on the other side of it, will be driven to the other end of the cylinder where the piston-rod will again act upon the handles of the cocks, valves, or slides, so as to reverse the flow of the steam, allowing that which has just impelled the piston to escape, and introducing steam from the boiler to the end of the cylinder at which the piston has just arrived. In this way the piston will be driven back to the other end of the cylinder, and so on alternately from end to end.

## VALVES AND SLIDES.

26. We are accustomed to consider the cylinder in a vertical position, to call the covers of its ends the top and bottom, and to speak of the up stroke and the down stroke of the piston. Such is very often the position of the apparatus, but it is not necessarily nor always so. The cylinder is often horizontal. It is almost always so, for example, in locomotive engines, and often so in steamboat engines. It is sometimes placed in an inclined position, and is sometimes moveable, changing its position with the motion of the piston.

The motion of the piston from end to end of the cylinder is called its **STROKE**, and the dimensions are usually expressed by stating the diameter of the piston and the length of the stroke.

27. The **EFFECTIVE PRESSURE** of steam per square inch on the piston is found by deducting from the actual pressure the reaction of the steam escaping, and the friction. This effective pressure being multiplied by the number of square inches in the piston, which is known by its diameter, gives the total effective force of the piston, and this force, multiplied by the number of feet through which the piston moves per minute, which is known by the length of the stroke, and observing the number of strokes per minute, will give the actual mechanical force produced per minute by the steam acting on the piston.

28. From what has been explained it will be apparent that much of the efficiency of the machine must depend upon the precision and regularity with which the steam is alternately admitted to and withdrawn from either end of the cylinder. If it be admitted or withdrawn too soon or too late, it will either obstruct the force of the piston, or delay its return to the other end of the cylinder. For these reasons, and also because there is much beauty and ingenuity in the contrivances by which the steam is admitted and withdrawn, we shall here explain a few of the expedients by which that object is attained.

29. In the arrangement represented in fig. 15, the object is attained by four conical valves, two placed at each end of the cylinder. Let B and B' be two steam boxes, B the upper, and B' the lower, communicating respectively with the top and bottom of the cylinder by proper passages D D'. Let two valves be placed in B, one, s, above the passage D, and the other, c, below it; and in like manner two other valves in the lower valve box B', one, s', above the passage D', and the other, c', below it. Above the valve s in the upper steam box is an opening at which the steam

Fig. 15.

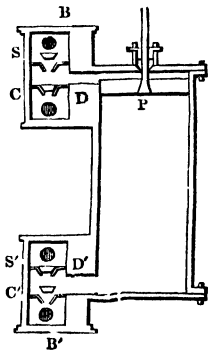

## THE STEAM ENGINE.

pipe from the boiler enters, and below the valve *c* is another opening, at which enters the exhausting pipe. In like manner, above the valve *s'* in the lower steam box enters a steam pipe leading from the boiler, and below the valve *c'* enters an exhausting pipe. It is evident, therefore, that steam can always be admitted above the piston by opening the valve *s*, and below it by opening the valve *s'*; and, in like manner, steam can be withdrawn from the cylinder above the piston, by opening the valve *c*, and from below it by opening the valve *c'*.

Supposing the piston *r* to be at the top of the cylinder, and the cylinder below the piston to be filled with pure steam, let the valves *s* and *c'* be opened, the valves *c* and *s'* being closed, as represented in fig. 15. Steam from the boiler will, therefore, flow in through the open valve *s*, and will press the piston downwards, while the steam that has filled the cylinder below the piston will pass through the open valve *c'* into the exhausting pipe. The piston will, therefore, be pressed downwards by the action of the steam above it. Having arrived at the bottom of the cylinder,

Fig. 16.

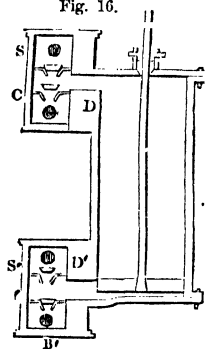

let the valves *s* and *c'* be both closed, and the valves *s'* and *c* be opened, as represented in fig. 16. Steam will now be admitted through the open valve *s'* and through the passage *D'* below the piston, while the steam which has just driven the piston downwards, will be drawn off through the open valve *c*, and the exhausting pipe, leaving in the cylinder above the piston a vacuum. The piston will, therefore, be pressed upwards by the action of the steam below it, and will ascend with the same force as that with which it had descended.

The alternate action of the piston upwards and downwards may evidently be continued by opening and closing the valves alternately in pairs. Whenever the piston is at the top of the cylinder, as represented in fig. 15, the valves *s* and *c'*, that is, the upper steam valve and the lower exhausting valve are opened; and the valves *c* and *s'*, that is, the upper exhausting valve and the lower steam valve, are closed; and when the piston has arrived at the bottom of the cylinder, as represented in fig. 16, the valves *c* and *s'*, that is, the upper exhausting valve and the lower steam valve, are opened, and the valves *s* and *c'*, that is, the upper steam valve and the lower exhausting valve, are closed.

If these valves, as has been here supposed, be opened and closed

## VALVES AND SLIDES.

at the moments at which the piston reaches the top and bottom of the cylinder, it is evident that they may be all worked by a single lever connected with them by proper mechanism. When the piston arrives at the top of the cylinder, this lever would be made to open the valves *s* and *c'*, and at the same time to close the valves *s'* and *c*; and when it arrives at the bottom of the cylinder, it would be made to close the valves *s* and *c'*, and to open the valves *s'* and *c*.

30. The methods of opening and closing the passages by means of lids slipping over them called slides, are those most generally used, and have infinitely various forms, although they differ one from another but little in the principle of their action. One of these expedients shown in fig. 17—18, will render the mode of

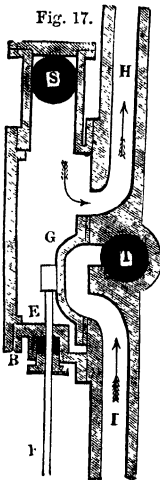

their action easily understood. *A B* is a steam-tight case attached to the side of the cylinder; *E F* is a rod, which receives an alternate motion, upwards and downwards, from the eccentric, or from whatever other part of the engine is intended to move the slide. This rod, passing through a stuffing box, moves the slide *G* upwards and downwards. *s* is the mouth of the steam pipe coming from the boiler; *T* is the mouth of a tube or pipe leading to the condenser; *H* is a passage leading to the top, and *I* to the bottom, of the cylinder. In the position

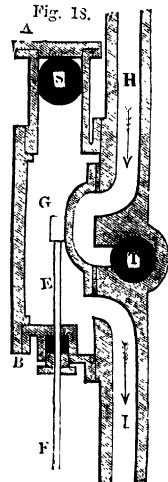

of the slide represented in fig. 17, the steam coming from the boiler through *s* passes through the space *H* to the top of the cylinder, while the steam from the bottom of the cylinder passes through the space *I* into the tube *T*, and goes to the condenser. When the rod *E F* is raised to the position represented in fig. 18, then the passage *H* is thrown into communication with the tube *T*, while the passage *I* is made to communicate with the tube *s*. Steam, therefore, passes from the boiler through *I* below the piston, while the steam which was above the piston, passing through *H* into *T*, goes to the condenser. Thus the single slide *G* performs the office of the four valves described in § 29.

## THE STEAM ENGINE.

31. Another form of slides is shown in fig. 19. The steam pipe proceeding from the boiler to the cylinder is represented at

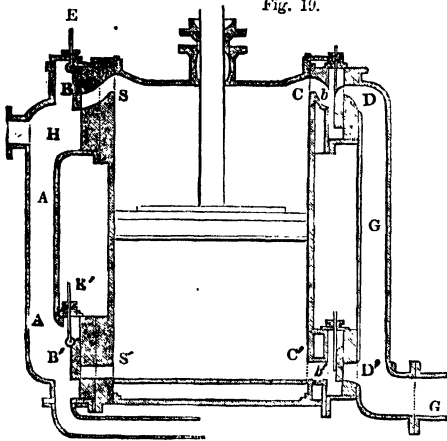

Fig. 19.

A A, and it communicates with passages *s* and *s'* leading to the top and bottom of the cylinder. These passages are formed in nozzles of iron or other hard metal cast upon the side of the cylinder. These nozzles present a smooth face outwards, upon which the slides *B B'*, also formed with smooth faces,

play. The slides *B B'* are attached by knuckle-joints to rods *E E'*, which move through stuffing-boxes, and the connection of these rods with the slides is such that the slides have play so as to detach their surfaces easily from the smooth surfaces of the nozzles when not pressed against these surfaces. The steam in the steam pipe *A A* will press against the backs of the slides *B B'*, and keep their faces in steam-tight contact with the smooth surfaces of the nozzles. These slides may be opened or closed by proper mechanism at any point of the stroke. When steam is to be admitted to the top of the cylinder, the upper slide is raised and the passage *s* opened; and when it is to be admitted to the bottom of the cylinder, the lower slide is raised and the passage *s'* opened: and its communication with the top or bottom of the cylinder is stopped by the lowering of these slides respectively. On the other side of the cylinder are provided two passages *c c'* leading to a pipe *G*, which is continued to the condenser. On this pipe are cast nozzles of iron or other metal presenting smooth faces towards the cylinder, and having passages *D D'* communicating between the top and bottom of the cylinder respectively and the pipe *G G* leading to the condenser. Two slides *b b'*, having smooth faces turned from the cylinder, and pressing upon the faces of the nozzles *D D'*, are governed by rods playing through stuffing-boxes, in the same manner as already described. The faces of these slides being turned from the cylinder, the steam in the cylinder having free

## STEAM COCKS.

communication with them, has a tendency to keep them by its pressure in steam-tight contact with the surfaces in which the apertures leading to the condenser are formed. These two slides may be opened or closed whenever it is necessary.

When the piston commences its descent, the upper steam slide is raised, so as to open the passage *s*, and admit steam above the piston; and the lower exhausting slide *b'* is also raised, so as to allow the steam below the piston to escape through *g*, the other two passages *s'* and *c* being closed by their respective slides. The slide which governs *s* is lowered at that part of the stroke at which the steam is intended to be cut off, the other slides remaining unchanged; and when the piston has reached the bottom of the cylinder, the lower steam slide opens the passage *s'*, and the upper exhausting slide opens the passage *c*, and at the same time the lower exhausting slide closes the passage *c'*. Steam being admitted below the piston through *s'*, and at the same time the steam above it being drawn away through the open passage *c* and the tube *g*, the piston ascends. When it has reached that point at which the steam is intended to be cut off, the slide which governs *s'* is lowered, the other slides remaining unaltered, and the upward stroke is completed in the same manner as the downward.

These four slides may be governed by a single lever, or they may be moved by separate means. From the small spaces between the several slides and the body of the cylinder, it will be evident that the waste of steam by this contrivance will be very small.

32. The admission and escape of the steam is sometimes

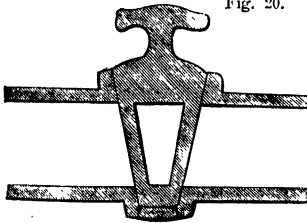

Fig. 20.

governed by cocks, more especially in engines constructed on a small scale. The most common form for cocks is that of a cylindrical or slightly conical plug (fig. 20), inserted in an aperture of corresponding magnitude passing across the pipe or passage which the cock is intended to open or close. One or more holes are pierced transversely in the cock, and when the cock is turned, so that these holes run in the direction of the tube, the passage through the tube is opened; but when the passage through the cock is placed at right angles to the tube, then the sides of the tube stop the ends of the passage in the cock, and the passage through the tube is obstructed. The simple cock is designed to open or close the passage through a single tube. When the cock is turned, as in fig. 21, so that the passage through the cock shall be at right angles to the length of the tube, then the passage

## THE STEAM ENGINE.

through the tube is stopped; but when the cock is turned from that position through a quarter of a revolution, as in fig. 22, then the passage through the cock takes the direction of the passage

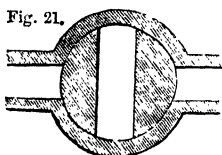

Fig. 21.

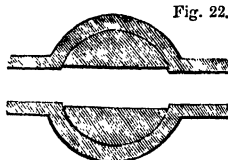

Fig. 22.

through the tube, and the cock is opened, and the passage through the tube unobstructed. In such a cock the passage may be more or less *throttled* by adjusting the position of the cock, so that a part of the opening in it shall be covered by the side of the tube.

33. It is sometimes required to put one tube or passage alternately in communication with two others. This is accomplished by a *two-way cock*. In this cock the passage is curved, opening usually at points on the surface of the cock, at right angles to each other. When it is required to put four passages alternately in communication by pairs, a *four-way cock* is used. Such a cock has two curved passages (fig. 23), each similar to the curved passage

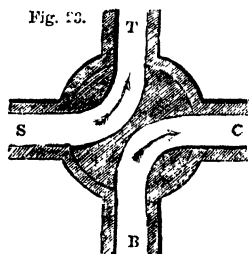

Fig. 23.

in the two-way cock. Let *s c B T* be the four tubes which it is required to throw alternately into communication by pairs. When the cock is in the position (fig. 23), the tube *s* communicates with *T*, and the tube *c* with *B*. By turning the cock through a quarter of a revolution, as in fig. 24, the tube *s* is made to communicate with *B*, and the tube *c* with *T*; and if the cock

continue to be turned at intervals through a quarter of a revolution, these changes of communication will continue to be alternately made. It is evident that this may be accomplished by turning the cock continually in the same direction.

The four-way cock is sometimes used as a substitute for the valves or slides to conduct the steam to and from the cylinder. If *s* represent a pipe conducting steam from the boiler, *c* the exhausting pipe, *T* the tube which leads to the top of the cylinder, and *B* that which leads to the bottom, then when the cock is in the position (fig. 23), steam would flow from the boiler to the top of the piston, while the steam below it would be drawn off: and in the position (fig. 24), steam would flow from the boiler to the bottom of the piston, while the steam above it would be

## FOUR-WAY COCK.

drawn off. Thus by turning the cock through a quarter of a revolution towards the termination of each stroke, the operation of the machine would be continued.

34. It will be understood from all that has been stated that the mechanical effect of the steam engine depends, other things being given, upon the excess of the pressure of the steam which impels the piston above the reaction of the steam which escapes at the end of the cylinder towards which the piston is moving. To whatever extent, therefore, this reaction is diminished, the efficacy of the engine will be increased.

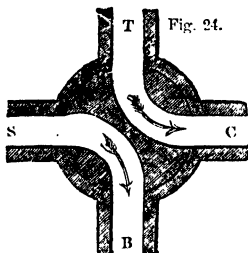

Steam engines are resolved into two distinct classes, according to the way in which the steam escaping from the cylinder is disposed of, called non-condensing and condensing engines, or, more commonly, though less properly, high pressure and low pressure engines. The objection to the latter denomination being that, although non-condensing engines must necessarily be worked with high pressure steam, condensing engines need not be worked with low pressure steam, as will presently appear.

In the class of non-condensing or high pressure engines, the exhaustion pipes of the cylinder open into the atmosphere; in the condensing or low pressure engines, they lead to an apparatus in which the steam is *condensed*, the name given to the process of reconvertng it into water by exposure to cold.

35. In non-condensing engines the exhausting pipe communicating with the external air, this air will, when the exhausting valve is open, have a tendency to rush into the cylinder, while the steam has, on the contrary, a tendency to rush out. If, in this case, the pressure of the steam were not greater than that of the atmosphere, its escape would be prevented by the counter pressure of the air, and as the pressure of the steam is the measure of its reaction against the piston, it follows that in this class of steam engine, the reaction on the piston must always be somewhat greater than the atmospheric pressure, which, as has been shown in vol. ii., p. 4, amounts on an average to 15lbs. per square inch.

Since, then, the piston of a non-condensing engine is subject, necessarily and constantly, to a reaction exceeding 15lbs. per square inch, the pressure of the steam by which it is impelled must greatly exceed 15lbs. per square inch. Thus a pressure of 30lbs. per square inch would give an effective pressure much less than 15lbs. per square inch, because, besides the reaction of the



## THE STEAM ENGINE.

steam, the impelling power is resisted by friction. A pressure of 45lbs. per square inch would give an effective force amounting to less than 30lbs. per square inch, and so on.

Notwithstanding the disadvantage of this reaction on the piston, and the consequent necessity of providing a boiler suitable to the production of steam of this high pressure, non-condensing engines are attended with several countervailing advantages which render them not only preferable in certain cases to condensing engines, but which render them efficient where the adoption of condensing engines would be altogether impracticable.

36. In condensing engines, the exhausting pipes which proceed from the ends of the cylinder lead to a reservoir or vessel called a condenser, in which the steam, being exposed to cold, is reduced to water. Now, since a cubic foot of steam will, when re-converted into liquid, form only about a cubic inch of water, it is plain that by this process of condensation, efficiently conducted, the steam escaping from the cylinder may be considered as passing into a vacuum, and therefore not only is it not subject to the resistance of the atmosphere, but to no resistance whatever, except what may arise from the contracted dimensions of the exhausting pipe. The conversion of the steam into water being, moreover, almost instantaneous, the reaction attending its escape, small as it is, is only momentary, and affects the piston only at the commencement of the stroke, throughout the remainder of which it will be subject to no reaction whatever.

Thus it appears, that, in condensing engines the pressure of the steam which impels the piston instead of being subject, as in non-condensing engines, to a reaction exceeding 15 lbs. per square inch, is subject to scarcely any reaction at all; and consequently its pressure, to be effective, need not exceed a few pounds, say from 4 lbs. to 6 lbs. per square inch. It is for this reason that condensing engines have been commonly called low-pressure engines.

But although low-pressure steam *may* be used in this class of engines, and in most cases *is* used, it is not thus used exclusively or necessarily. Steam of any pressure, however high, may be worked in them, and the condensing apparatus will still render equal service. In certain applications of the engine, steam having a pressure several times greater than that of the atmosphere is worked with great advantage in engines constructed on this principle.

37. Since the condensing apparatus discharges such important functions, it will be useful to show its structure and arrangement, in connection with the piston and cylinder.

A section of such an apparatus is shown in fig. 25. A cistern,

## CONDENSER.

c c, is filled with cold water. Immersed in it is a metal vessel, B, called the condenser. A pipe, s s, connects this condenser with the exhausting pipe of the cylinder, of which s s may be

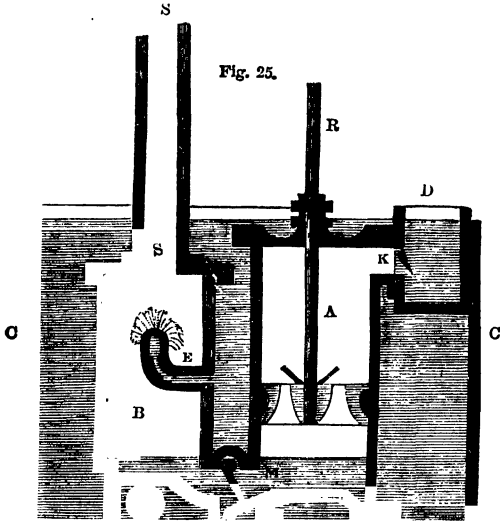

considered as the continuation. A jet-pipe, E, enters the condenser, and is bent upwards. It is terminated with a piece pierced with holes like the rose of a watering-pot, and the cold water of the cistern, c c, being pressed in through the pipe, E, is thrown up in the condenser, as shown in the figure. The steam, escaping from the cylinder along the pipe, s s, encounters this cold jet and is instantly condensed. Mixing with the cold water of the jet, it forms warm water, which collects in the bottom of the condenser.

If means were not provided for the removal of this water, the vessel B would soon become choked with it, so as to arrest the action of the apparatus.

38. But there is also another effect, which it is important to explain. Water as it commonly exists always contains more or less air fixed in or mingled with it. The air thus fixed in the water of the cistern, c c, is disengaged in greater or less quantity by the heat to which it is exposed when the steam is mixed with it in the vessel B. This air, rising through the tube, s s, offers more or less resistance to the escape of the steam, and reacts upon the piston to the detriment of the moving power. Its accumula-

## THE STEAM ENGINE.

tion, if not removed, would soon obstruct and altogether arrest the action of the machine.

This air, as well as the warm water deposited in the bottom of the condenser, is withdrawn by a pump, A, called the AIR-PUMP, because of its use in the removal of the air just mentioned. In the piston of this pump are valves which open upwards, so that when the piston descends the water and air force themselves through the valves, and when it ascends it lifts the water and air which have thus passed through the valves, and throws them into a small reservoir, D, through a valve, K. This reservoir, D, is called the hot cistern, the water deposited in it having a temperature more or less elevated, owing to the steam which has been condensed by it.

The ascent of the piston of the air-pump has also the effect of drawing by suction, as it is commonly called, the water and air from the condenser, B, through the valve M into the bottom of the barrel of the air-pump, from which they cannot get back into the condenser, inasmuch as the valve, M, opens towards the air-pump, and their returning pressure only closes it more firmly.

39. The continual affluence of the steam to the vessel B, and the water constantly passing through it, the air-pump, and the cistern, D, would at length raise the temperature of the water in the cistern, C C, in which the condensing apparatus is immersed, to such a point that the jet projected into the condenser would be no longer cold enough to condense the steam.

To prevent this a pump, called the cold-water pump, is provided, which throws into the cistern a sufficient quantity of cold water. This water is introduced near the bottom of the cistern, a waste-pipe being provided at the top by which the warm water, which always collects near the upper surface, flows off. In this way the temperature of the water in the cistern, C C, is kept sufficiently low, notwithstanding the heat proceeding from the condensing vessels.

40. To prevent the accumulation of warm water in the cistern, D, a pump called the hot-water pump is connected with it, by which the water is drawn off from it and transferred to the feeding apparatus of the boiler. Thus a part of the heat given out by the condensed steam, and which has already done duty in working the piston, is returned to the boiler to take another round of duty.

Thus it appears that the condensing apparatus consists of the cold cistern, C C, the cold-water pump which supplies it, the condenser, B, the air-pump, A, the hot cistern, D, and the hot-water pump, which draws the water from it.

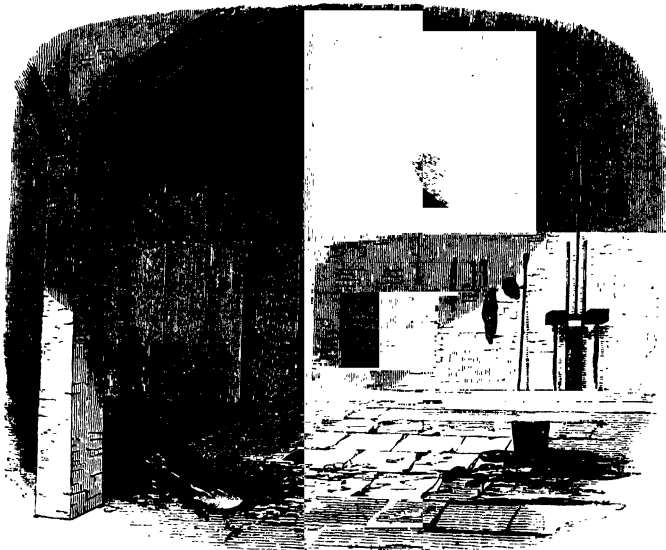

FURNACE AT THE CITY SAW MILLS.

## THE STEAM ENGINE.

### CHAPTER III.

41. Comparative merits of the two kinds of engines.—42. Various modes of transmitting force.—43. Description of a factory engine.—44. The governor.—45. The eccentric.—46. The fly-wheel.—47. Parallel motion.—48. Barometer gauge.—49. How to compute the effective moving force of the piston.—50. Method not considered sufficiently accurate.—51. Indicator.—52. Mode of recording its positions.—53. Its application in finding effective force.—54. Watt's counter.—55. Conclusion.

41. THAT the advantages arising from the diminished reaction on the piston, produced by the condensation of the steam, are not altogether to be placed to the account of increased moving power, will be apparent when it is observed that no inconsiderable part of the power thus gained is absorbed by the cold-water pump, the air pump, and the hot-water pump, all of which are worked by the engine. Neither is the vacuum into which the piston moves,

## THE STEAM ENGINE.

so absolute as it might at first appear to be. It is not found practicable to keep the water in the condenser at a temperature lower than  $100^{\circ}$ , and at that temperature steam is evolved which has a pressure of about one pound per square inch, which, after all, will still react upon the piston.

In comparing, then, the non-condensing and condensing engine, it is apparent, that while the latter gives a much greater amount of moving power with the same rate of evaporation, and consequently with the same consumption of fuel, the former is vastly more simple in its mechanism, lighter in its weight, more inexpensive in its construction and maintenance, and much more portable.

42. From what has been explained, it will be understood how the piston-rod is made to move with any desired force alternately in one direction or other, through a space equal to the stroke of the piston, or, what is the same, to the length of the cylinder.

The manner in which this force is transmitted to the object to which the engine is applied, is extremely various. In some cases the end of the piston-rod is connected with that of a vibrating beam, to which a motion of oscillation is imparted like that of the handle of a pump. In other cases it is put in connection with a winch or crank, by which a motion of revolution is imparted to an axle or shaft, in the same manner as a man working at a windlass causes a rope to wind upon its axle. In other cases it is connected with a wheel, to which it imparts rotation, as in some forms of the locomotive engine. In short, the expedients by which the alternate force of the piston is applied to the particular work to be performed by the engine are so numerous, and differ so much one from another, that it would be quite impossible to give any general account which would include them.

43. To convey, however, some idea of one of the most common methods of transmitting the force of the piston, we shall take the case of the steam engine generally used to propel the machinery of the larger class of factories, a view of which is given in fig. 26. The several parts will be easily understood, after what has been stated, without further explanation.

c is the steam cylinder.

P, the steam piston.

v v', the valves for admitting and withdrawing the steam, at each end of the cylinder.

R, the piston-rod of the air pump.

L, the piston-rod of the hot-water pump.

N, the piston-rod of the cold-water pump.

I, the handle of the cock by which the jet in the condenser is made to play with more or less force.

b, d, g, c, a system of jointed rods called the parallel motion, by

## FACTORY ENGINE.

means of which the motion of the beam in the arc of a circle is rendered compatible with that of the piston-rod in a straight line.

Fig. 26.

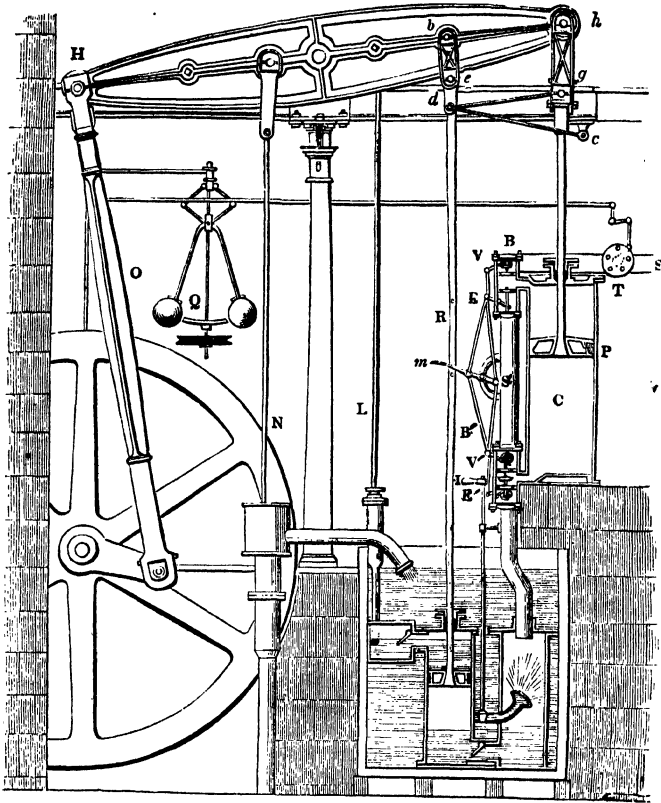

*h*, the pin on the end of the beam connected with the end of the piston-rod by the joint *h g*.

*b*, the pin on the beam connected with the piston-rod of the air pump by the joint *b d*.

*H*, the pin on the working end of the beam.

*o*, a rod called the connecting rod, by which the end *H* of the beam is connected with a crank or winch upon the main shaft, to which it is required to impart rotation.

## THE STEAM ENGINE.

*m*, a lever jointed to a system of rods by which the valves *v* *v'* admitting and withdrawing the steam at the top and bottom of the cylinder are opened and closed. This lever *m* is acted upon by pins which project from the piston-rod of the air pump, and which appear in the figure. When the piston descends, the upper pin strikes the arm *m*, which closes the upper steam valve and lower exhausting valve, and opens the lower steam valve and upper exhausting valve, so that the steam is admitted below and withdrawn from above the piston, which is accordingly driven up. When the up-stroke is nearly terminated, the lower pin on the rod *r* strikes the arm *m*, driving it upwards, and closes the upper exhausting valve and the lower steam valve, while it opens the upper steam valve and lower exhausting valve, by which means the piston is driven down.

This method of working the valves is however at present rarely used, being replaced by another expedient which we shall presently describe.

*s*, the pipe leading from the boiler by which steam is supplied to the cylinder to impel the piston. This pipe communicates with both ends of the cylinder by means of a passage *s'*, which is parallel to the cylinder.

*r*, the handle of a valve called the throttle valve, which is within the steam pipe *s*, and which is turned by the handle, so as to contract or widen more or less the passage for the steam. By this means the supply of steam to the cylinder is increased or diminished.

*g*, a system of revolving balls called the governor, with which the handle *r* of the throttle valve is connected by a series of levers and joints, which are so constructed, that when the balls recede from the axis of the governor, the valve is more or less closed, and when they fall near the axis, the valve is fully open. These balls receive a motion of revolution from the main shaft upon which the crank is constructed by means of a band or by toothed wheels. In either case their velocity of rotation will be always proportionate to that of the shaft. In all applications of the engine to the purposes of manufacture and the arts, there is some determinate velocity which is required to be given to the shaft. If steam be supplied in too great quantity to the cylinder, the motion given to the shaft will be too rapid; and if it be supplied in too small quantity, the motion will be too slow.

Such irregularities of motion are prevented by the governor. The moment the motion begins to be too rapid, the centrifugal force produced by the revolution causes the balls to fly out, to recede from the axis, and to close more or less the throttle valve. If, on the contrary, the motion begins to be too slow, the balls fall in, approach the axis, and open the throttle valve. Thus

## GOVERNOR.

every undue increase of speed diminishes the supply of steam, and moderates the velocity; and every undue decrease of speed increases the supply of steam, and augments the velocity. In this manner the action of the governor keeps the engine constantly moving at a regulated rate.

44. The manner in which the governor opens the throttle valve will be still more easily understood by the aid of fig. 27.

A small grooved wheel A B is attached to a vertical spindle supported in pivots or sockets C and D, in which it is capable of revolving. An endless cord works in the groove A B, and is carried over proper pulleys to the axle of the fly-wheel, where it likewise works in a groove. When this cord is properly tightened,

Fig. 27.

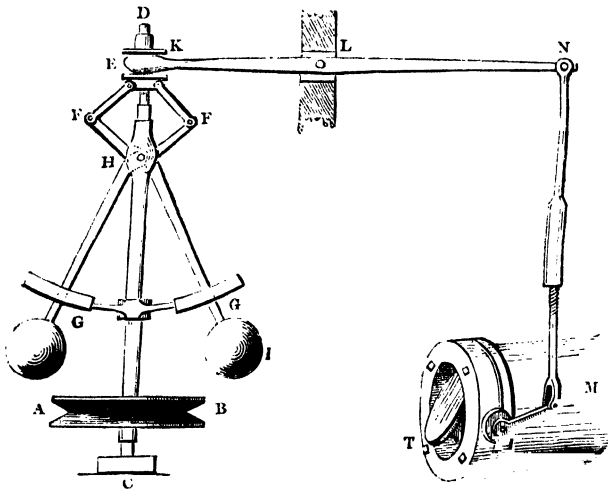

the motion of the fly-wheel will give motion to the wheel A B, so that the velocity of the one will be subject to all the changes incidental to the velocity of the other. By this means the speed of the grooved wheel A B may be considered as representing the speed of the fly-wheel, and of the machinery which the axle of the fly-wheel drives.

It is evident that the same end might be obtained by substituting for the grooved wheel A B a toothed wheel, which might be connected by other toothed wheels, and proper shafts and axles with the axle of the fly-wheel.



## THE STEAM ENGINE.

A ring or collar *E* is placed on the upright spindle, so as to be capable of moving freely upwards and downwards. To this ring are attached by pivots two short levers, *E F*, the pivots or joints at *E* allowing these levers to play upon them. At *F* these levers are joined by pivots to other levers *F G*, which cross each other at *H*, where an axle or pin passes through them, and attaches them to the upright spindle *C D*. These intersecting levers are capable, however, of playing on this axle or pin *H*. To the ends *G* of these levers are attached two heavy balls of metal. The levers *F G* pass through slits in a metallic arc attached to the upright spindle, so as to be capable of revolving upon it. If the balls are drawn outwards from the vertical axis, it is evident that the ends *F* of the levers will be drawn down, and therefore the pivots *E* likewise drawn down. In fact, the angles *E F H* will become more acute, and the angles *F E F* more obtuse. By these means the sliding ring *E* will be drawn down. To this sliding ring *E*, and immediately above it, is attached a grooved collar, which slides on the vertical spindle upwards and downwards with the ring *E*. In the grooved collar are inserted the prongs of a fork *K*, formed at the end of the lever *K L*, the fulcrum or pivot of the lever being at *L*. By this arrangement, when the divergence of the balls causes the collar *E* to be drawn down, the fork *K*, whose prongs are inserted in the groove of that collar, is likewise drawn down; and, on the other hand, when by reason of the balls falling towards the vertical spindle, the collar *E* is raised, the fork *K* is likewise raised.

The ascent and descent of the fork *K* necessarily produce a contrary motion in the other end *N* of the lever. This end is connected by a rod, or system of rods, with the end *M* of the short lever which works the throttle valve *T*. By such means the motion of the balls, towards or from the vertical spindle, produces in the throttle valve a corresponding motion; and they are so connected that the divergence of the balls will cause the throttle valve to close, while their descent towards the vertical spindle will cause it to open.

These arrangements being comprehended, let us suppose that, either by reason of a diminished load upon the engine or an increased activity of the boiler, the speed has a tendency to increase. This would impart increased velocity to the grooved wheel *A B*, which would cause the balls to revolve with an accelerated speed. The centrifugal force which attends their motion would therefore give them a tendency to move from the axle, or to diverge. This would cause, by the means already explained, the throttle valve *T* to be partially closed, by which the supply of steam from the boiler to the cylinder would be

## ECCENTRIC.

diminished, and the energy of the moving power, therefore, mitigated. The undue increase of speed would thereby be prevented.

If, on the other hand, either by an increase of the load, or a diminished activity in the boiler, the speed of the machine was lessened, a corresponding diminution of velocity would take place in the grooved wheel A B. This would cause the balls to revolve with less speed, and the centrifugal force produced by their circular motion would be diminished. This force being thus no longer able fully to counteract their gravity, they would fall towards the spindle, which would cause, as already explained, the throttle valve to be more fully opened. This would produce a more ample supply of steam to the cylinder, by which the velocity of the machine would be restored to its proper amount.

45. The method of working the valves by means of pins projecting from the rod of the air pump has been in most cases superseded by an apparatus called an *eccentric*, by which the motion of the axle of the fly-wheel is made to open and close the valves at the proper times.

An eccentric is a metallic circle attached to a revolving axle, so that the centre of the circle shall not coincide with the centre round which the axle revolves. Let us suppose that *c* (fig. 28) is a square revolving shaft. Let a circular plate of metal, B D,

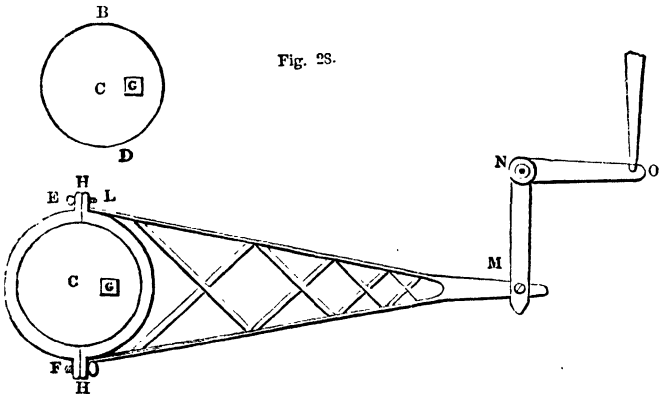

having its centre at *c*, have a square hole cut in it corresponding to the shaft, *g*, and let the shaft, *g*, pass through this square aperture, so that the circular plate, B D, shall be fastened upon the shaft, and capable of revolving with it as the shaft revolves. The centre, *c*, of the circular plate will be carried round the centre, *g*, of the revolving shaft, and will describe round it a

## THE STEAM ENGINE.

circle, the radius of which will be the distance of the centre,  $c$ , of the circular plate from the centre of the shaft. Such circular plate, so placed upon a shaft, and revolving with it, is an *eccentric*.

Let  $EF$  be a metallic ring, formed of two semicircles of metal screwed together at  $H$ , so as to be capable, by the adjustment of the screws, of having the circular aperture formed by the ring enlarged and diminished within certain small limits. Let this circular aperture be supposed to be equal to the magnitude of the eccentric,  $BD$ . To the circular ring,  $EF$ , let an arm,  $LM$ , be attached. If the ring,  $EF$ , be placed around the eccentric, and the screws,  $H$ , be so adjusted as to allow the eccentric to revolve within the ring,  $EF$ , then, while the eccentric revolves, the ring not partaking of its revolution, the arm,  $LM$ , will be alternately driven to the right and to the left, by the motion of the centre,  $c$ , of the eccentric as it revolves round the centre,  $G$ , of the axle. When the centre,  $c$ , of the eccentric is in the same horizontal line with the centre,  $G$ , and to the left of it, then the position of  $LM$  will be that which is represented in fig. 28; but when, after half a revolution of the main axle, the centre,  $c$ , of the eccentric is thrown on the other side of the centre,  $G$ , then the point,  $M$ , will be transferred to the right, to a distance equal to twice the distance  $cG$ . Thus, as the eccentric revolves within the ring,  $EF$ , that ring, together with the arm,  $LM$ , will be alternately driven right and left, through a space equal to twice the distance between the centre of the eccentric and the centre of the revolving shaft.

If we suppose a notch formed at the extremity of the arm,  $LM$ , which is capable of embracing a lever,  $NM$ , moveable on a pivot at  $N$ , the motion of the eccentric would give to such a lever an alternate motion from right to left, and *vice versa*. If we suppose another lever,  $NO$ , connected with  $NM$ , and at right angles to it, forming what is called a bell-crank, then the alternate motion received by  $M$ , from right to left, would give a corresponding motion to the extremity,  $O$ , of the lever,  $NO$ , upwards and downwards. If this last point,  $O$ , were attached to a vertical arm or shaft, it would impart to such arm or shaft an alternate motion upwards and downwards, the extent of which would be regulated by the length of the levers respectively.

By such a contrivance the revolution of the shaft is made to give an alternate vertical motion of any required extent to a vertical shaft placed near the cylinder, which may be so connected with the valves as to open and close them. Since the upward and downward motion of this vertical shaft is governed by the alternate motion of the centre,  $c$ , to the right and to the left of the centre,

## FLY-WHEEL.

6, it is evident that, by the adjustment of the eccentric upon the shaft, the valves may be opened and closed at any required position of the crank, and therefore at any required position of the piston in the cylinder.

Such is the contrivance by which the valves, whatever form may be given to them, are now almost universally worked in double-acting steam engines.

46. Notwithstanding the regulating influence of the governor, the motion of the engine would still be subject to a certain inequality, owing to the varying action of the connecting rod, *o* (fig. 26), on the crank. It will be quite evident that this action is most efficient when *o* is placed at right angles to the crank, which it is twice in every revolution, but that the more oblique it is to the crank the less efficient will be its action upon it.

Now this inequality is effaced very nearly, if not altogether, by means of a large and massive wheel of cast iron, called the FLY-WHEEL, which is keyed upon the axle of the crank so as to revolve with it, as shown in fig. 26. This wheel being well constructed, and nicely balanced on its axle, is subject to very little resistance from friction; any moving force which it receives it therefore retains, and is ready to impart such moving force to the main axle whenever that axle ceases to be driven by the power. When the crank, therefore, is in those positions in which the action of the power upon it is most efficient, a portion of the energy of the power is expended in increasing the velocity of the mass of matter composing the fly-wheel. As the crank approaches the dead points, that is the points where it is in the same straight line with the connecting rod, the effect of the moving power upon the axle and upon the crank is gradually enfeebled, and at these points vanishes altogether. The momentum which has been imparted to the fly-wheel then comes into play, and carries forward the axle and crank out of the dead points with a velocity very little less than that which it had when the crank was in the most favourable position for receiving the action of the moving power.

By this expedient, the motion of revolution received by the axle from the steam piston is subject to no other variation than just the amount of change of momentum in the great mass of the fly-wheel which is sufficient to extricate the crank twice in every revolution from the mechanical dilemma to which its peculiar form exposes it; and this change of velocity may be reduced to as small an amount as can be requisite by giving the necessary weight and magnitude to the fly-wheel.

47. The combination of jointed rods represented at *c d g b*, in fig. 26, called the parallel motion, constitutes one of the many inventions of Watt, which has always excited the greatest admi-

## THE STEAM ENGINE.

ration, by reason of the remarkable geometrical intuition which it manifested in one who was uninstructed in the advanced principles of geometrical analysis upon which the perfection of its action depends. Although this beautiful arrangement has been very generally superseded by others of greater simplicity, and of sufficient, though less, precision of action, it will not be uninteresting here to attempt a brief and popular explanation of the principles upon which its performance depends.

The end of the beam with which the top of the piston-rod is connected vibrating upon its centre, necessarily plays in a circular arc, the convexity of which is presented to the right in fig. 26. Now it is clear, that if the end  $g$  of the piston-rod were immediately jointed to this end of the beam, it would be bent towards the right through the convexity of the arc, while the beam moves from its highest or lowest position to the middle of its play, and that while it moves from the latter to the former position it will be deflected back towards the left. Now, the efficient performance of the engine absolutely requires that the piston-rod should not be exposed to any such alternate strain, but that it should be guided in a perfectly straight line in the direction of the axis of the cylinder; and this is precisely what the parallel motion accomplishes.

As we have just explained, the point  $h$  plays in an arc whose convexity is presented to the *right*. Now, the joint  $c d$ , or *link*, as it is called, moves upon a fixed centre,  $c$ , and consequently plays in an arc whose convexity is presented to the *left*, that is, contrary to the former. While the point  $h$  throws the upper end of the link  $g h$  to the right, by reason of the convexity of its play being on that side, the point  $d$  throws the lower end  $g$  to the left, by reason of its convexity being on the contrary side.

Now, the proportion of the lengths of the rods is so nicely adjusted, that the effect of the rod  $c d$  in throwing the point  $g$  to the left is exactly equal to the effect of the beam in throwing it to the right; and the consequence of this mutual compensation is, that the point  $g$ , to which the end of the piston-rod is jointed, is thrown neither to the right nor to the left, but is moved upwards and downwards in a straight line.

48. To be enabled to verify the efficiency of the engine and enforce a due economy of fuel, it is necessary to be provided with indicators, by which at all times the effective force of the piston can be ascertained. Now this effective force depends conjointly upon the pressure of the steam which moves the piston and the reaction of the uncondensed steam, and of the gases which the air pump may fail to withdraw from the condenser. Two mercurial gauges are accordingly provided for this purpose in all large stationary engines which are constructed on the condensing principle.

## PARALLEL MOTION—BAROMETER GAUGE.

The force of steam which moves the piston is indicated by the steam gauge already described, and which is shown attached to the exposed end,  $\kappa$ , of the boiler in fig. 7. The reaction of the uncondensed steam and gases is indicated by a gauge called the barometer gauge, inasmuch as it would be in fact a barometer if an absolute vacuum were produced before the piston. This gauge consists of a glass tube,  $A B$  (fig. 29), more than thirty inches long, and open at both ends, placed in an upright or vertical position, having the lower end  $B$  immersed in a cistern of mercury,  $c$ . To the upper end is attached a metal tube, which communicates with the condenser, in which a constant vacuum, or rather high degree of rarefaction, is sustained. The same vacuum must therefore exist in the tube  $A B$ , above the level of the mercury, and the atmospheric pressure on the surface of the mercury in the cistern  $c$  will force the mercury up in the tube  $A B$ , until the column which is suspended in it is equal to the difference between the atmospheric pressure and the pressure of the uncondensed steam. The difference between the column of mercury sustained in this instrument and in the common barometer, will determine the strength of the uncondensed steam, allowing a force proportional to one pound per square inch for every two inches of mercury in the difference of the two columns. In a well-constructed engine which is in good order, there is very little difference between the altitude in the barometer gauge and the common barometer.

Fig. 29.



49. To compute the force with which the piston descends, thus becomes a very simple arithmetical process. First, ascertain the difference of the levels of the mercury in the steam gauge; this gives the excess of the steam pressure above the atmospheric pressure. Then find the height of the mercury in the barometer gauge; this gives the excess of the atmospheric pressure above the uncondensed steam. Hence, if these two heights be added together, we shall obtain the excess of the impelling force of the steam from the boiler, on the one side of the piston, above the resistance of the uncondensed steam on the other side; this will give the effective impelling force. Now, if one pound be allowed for every two inches of mercury in the two columns just mentioned, we shall have the number of pounds of impelling pressure on every square inch of the piston. Then, if the number of square inches in the section of the piston be found, and multiplied by the number of pounds on each square inch, the force with which it moves will be obtained.

From what we have stated it appears that, in order to estimate

## THE STEAM ENGINE.

the force with which the piston is urged, it is necessary to refer to both the barometer and the steam gauge. This double computation may be obviated by making one gauge serve both purposes. If the end *c* of the steam gauge (fig. 7), instead of communicating with the atmosphere, were continued to the condenser, we should have the pressure of the steam acting upon the mercury in the tube *BA*, and the pressure of the uncondensed vapour which resists the piston acting on the mercury in the tube *BC*. Hence the difference of the levels of the mercury in the tubes would at once indicate the difference between the force of the steam and that of the uncondensed vapour, which is the effective force with which the piston is urged.

50. Perfect as these expedients must appear, they have been deemed insufficient as indicators of an element so important as the economy of steam power. If, during the motion of the piston from end to end of the cylinder, the steam really acted upon it with an uniform force, and if the reaction against it were also uniform, then the steam and barometer gauges would give an exact measure of the effective power. But many causes co-operate in preventing such uniformity of action and reaction.

In the first place, the end of the cylinder from which the piston moves is never left in free communication with the boiler through the entire stroke. In all cases the steam is shut off by closing the steam valve before the stroke is completed, and if the engine works by expansion, which most engines do, the steam is shut off after a certain part of the stroke—such as three-fourths, two-thirds, a half, and sometimes even a third, or a fourth—has been made. In all such cases, the pressure on the piston after the steam has been shut off becomes less and less, as the steam in the cylinder expands by the advance of the piston.

Neither is the reaction uniform; for the condensation of the steam in the condenser is not absolutely instantaneous, though very rapid, but still less is the removal of the air and gases, which are fixed in the water injected to produce the condensation, instantaneous. The action of the air pump is gradual, and consequently the reaction on the piston, considerable at first, becomes gradually less and less towards the end of the stroke.

Now it is clear that, under these circumstances, the effective power of the piston, being always measured by the excess of the impelling force over the reaction, must vary continually from the beginning to the end of the stroke; and as the total effective force must consist of the aggregate of this varying action, it would seem to be a problem of the greatest practical difficulty to ascertain it.

51. Nevertheless, the inexhaustible resources of the genius of Watt, which surmounted so many other difficulties, did not shrink

## INDICATOR.

before this; and produced an instrument of most felicitous perfection, called an Indicator, by which the object was perfectly and simply attained.

This contrivance consists of a cylinder of about  $1\frac{3}{4}$  inch in diameter, and 8 inches in length. It is bored with great accuracy, and fitted with a solid piston moving steam-tight in it with very little friction. The rod of this piston is guided in the direction of the axis of the cylinder through a collar in the top, so as not to be subject to friction in any part of its play. At the bottom of the cylinder is a pipe governed by a stop-cock and terminated in a screw, by which the instrument may be screwed on the top of the steam cylinder of the engine. In this position, if the stop-cock of the indicator be opened, a free communication will be made between the cylinder of the indicator and that of the engine. The piston-rod of the indicator is attached to a spiral spring, which is capable of extension and compression, and which by its elasticity is capable of measuring the force which extends or compresses it in the same manner as a spring steel-yard or balance. If a scale be attached to the instrument at any point on the piston-rod to which an index might be attached, then the position of that index upon the scale would be governed by the position of the indicator piston in its cylinder. If any force pressed the indicator piston upwards, so as to compress the spring, the index would rise upon the scale; and if, on the other hand, a force pressed the indicator piston downwards, then the spiral spring would be extended, and the index on the piston-rod descend upon the scale. In each case the force of the spring, whether compressed or extended, would be equal to the force urging the indicator piston, and the scale might be so divided as to show the amount of this force.

Now let the instrument be supposed to be screwed upon the top of the cylinder of a steam engine, and the stop-cock opened so as to leave a free communication between the cylinder of the indicator below its piston and the cylinder of the steam engine above the steam piston. At the moment the upper steam valve is opened, the steam rushing in upon the steam piston will also pass into the indicator, and press the indicator piston upwards: the index upon its piston-rod will point upon the scale to the amount of pressure thus exerted. As the steam piston descends, the indicator piston will vary its position with the varying pressure of the steam in the cylinder, and the index on the piston-rod will play upon the scale, so as to show the pressure of the steam at each point during the descent of the piston.

52. If it were possible to observe and record the varying positions of the index on the piston-rod of the indicator, and to refer each of these varying positions to the corresponding point of the



## THE STEAM ENGINE.

descending stroke, we should then be able to declare the actual pressure of the steam at every point of the stroke. But it is evident that such an observation would not be practicable. A method, however, was contrived by Mr. Southern, an assistant of Messrs. Boulton and Watt, by which this is perfectly effected. A square piece of paper, or card, is stretched upon a board, which slides in grooves formed in a frame. This frame is placed in a vertical position near the indicator, so that the paper may be moved in a horizontal direction backwards and forwards, through a space of fourteen or fifteen inches. Instead of an index, a pencil is attached to the indicator of the piston-rod: this pencil is lightly pressed by a spring against the paper above mentioned, and as the paper is moved in a horizontal direction, the pencil would trace upon it a line. If the pencil were stationary, this line would be straight and horizontal, but if the pencil were subject to a vertical motion, the line traced on the paper moved under the pencil horizontally would be a curve, the form of which would depend on the vertical motion of the pencil. The board thus supporting the paper is put into connection by a light cord carried over pulleys with some part of the parallel motion, by which it is alternately moved to the right and to the left. As the piston ascends or descends, the whole play of the board in the horizontal direction will therefore represent the length of the stroke, and every fractional part of that play will correspond to a proportional part of the stroke of the steam piston.

53. The apparatus being thus arranged, let us suppose the steam piston at the top of the cylinder commencing its descent. As it descends, the pencil attached to the indicator piston-rod varies its height according to the varying pressure of the steam in the cylinder. At the same time the paper is moved uniformly under the pencil, and a curved line is traced upon it from right to left. When the piston has reached the bottom of the cylinder, the upper exhausting valve is opened, and the steam drawn off to the condenser. The indicator piston being immediately relieved from a part of the pressure acting upon it, descends, and with it the pencil also descends; but at the same time the steam piston has begun to ascend, and the paper to return from left to right under the pencil. While the steam piston continues to ascend, the condensation becomes more and more perfect, and the vacuum in the cylinder, and therefore also in the indicator, being gradually increased in power, the atmospheric pressure above the indicator piston presses it downwards and stretches the spring. The pencil meanwhile, with the paper moving under it from right to left, traces a second curve. As the former curve showed the actual pressure of the steam impelling the piston in its descent, this latter

## INDICATOR.

will show the pressure of the uncondensed steam resisting the piston in its ascent, and a comparison of the two will exhibit the effective force on the piston. Fig 30 represents such a diagram as would be produced by this instrument. *A B C* is the curve traced by the pencil during the descent of the piston, and *C D E*

Fig. 30.

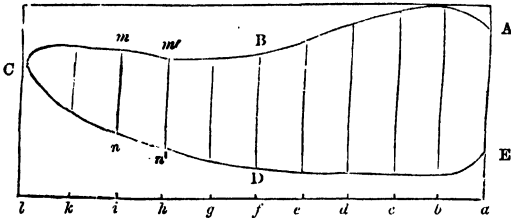

that during its ascent. *A* is the position of the pencil at the moment the piston commences its descent, *B* is its position at the middle of the stroke, and *C* at the termination of the stroke. On closing the upper steam valve and closing the exhausting valve, the indicator piston being gradually relieved from the pressure of the steam, the pencil descends, and at the same time the paper moving from left to right, the pencil traces the curve *C D E*, the gradual descent of this curve showing the progressive increase of the vacuum. As the atmospheric pressure constantly acts above the piston of the indicator, its position will be determined by the difference between the atmospheric pressure and the pressure of the steam below it; and therefore the difference between the heights of the pencil at corresponding points in the ascending and descending stroke will express the difference between the pressure of the steam impelling the piston in the ascent and resisting it in the descent at these points. Thus, at the middle of the stroke, the line *B D* will express the extent to which the spring governing the indicator piston would be stretched by the difference between the force of steam impelling the piston at the middle of the descending stroke, and the force of steam resisting it at the middle of the ascending stroke. The force, therefore, measured by the line *B D* will be the effective force on the piston at that point, and the same may be said of every part of the diagram produced by the indicator.

The whole mechanical effect produced by the stroke of the piston being composed of the aggregate of all its varying effects throughout the stroke, the determination of its amount is a matter of easy calculation by the measurement of the diagram supplied

## THE STEAM ENGINE.

by the indicator. Let the horizontal play of the pencil from  $a$  to  $c$  be divided into any proposed number of equal parts, say ten: at the middle of the stroke,  $B D$  expresses the effective force on the piston; and if this be considered to be uniform through the tenth part of the stroke, as from  $f$  to  $g$ , then the number of pounds expressed by  $B D$  multiplied by the tenth part of the stroke expressed in parts of a foot, will be the mechanical effect through that part of the stroke expressed in pounds' weight raised one foot. In like manner  $m n$  will express the effective force on the piston after three-fourths of the stroke have been performed, and if this be multiplied by a tenth part of the stroke as before, the mechanical effect similarly expressed will be obtained; and the same process being applied to every successive tenth part of the stroke, and the numerical results thus obtained being added together, the whole effect of the stroke will be obtained, expressed in pounds' weight raised one foot.

54. By means of the indicator, the actual mechanical effect produced by each stroke of the engine can be obtained, and if the actual number of strokes made in any given time be known, the whole effect of the moving power would be determined. An instrument called a *counter* was also contrived by Watt, to be attached either to the working beam, or to any other reciprocating part of the engine. This instrument consisted of a train of wheel-work with governing hands, or indices moved upon divided dials, like the hands of a clock. A record of the strokes was preserved by means precisely similar to those by which the hands of a clock or time-piece indicate and record the number of vibrations of the pendulum or balance-wheel.

55. Such, then, is the machine, and such the principal expedients by which it has been adapted as a moving power of unparalleled importance and efficiency in all the industrial arts. In certain applications of the engine some of these provisions are unnecessary or inapplicable. In others supplementary expedients are required and supplied. Our present purpose, however, will be attained, if we have succeeded in rendering clearly intelligible the general principle upon which the machine as described above acts, and the special uses of the accessories that have been described. These being well understood, no great difficulty will be encountered in comprehending the mechanism and the action of any special form of engine.

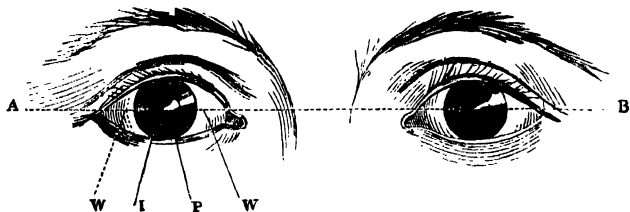

Fig. 1.

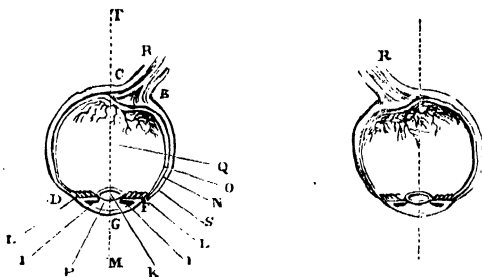

Fig. 2.

## THE EYE.

### CHAPTER I.

1. Pleasures and advantages of the power of vision.—2. Reasons why a knowledge of the structure and functions of the eye is desirable.—3. Description of the eye.—4. Sclerotica and cornea.—5. Aqueous humour, pupil, and iris.—6. Crystalline humour and ciliary processes.—7. Choroid.—8. Retina and vitreous humour.—9. Axis of the eye and optic nerve.—10. Numerical data.—11. Limits of the play of the eye.—12. Achromatism of the eye.—13-16. How vision is caused.—17. Conditions of perfect vision.—18. Distinctness of the image.—19. Parallel rays.—20, 21. Defects of vision and their remedies.—22-24. Power of adaptation.—25-29. Limits of this power.—30, 31.—Causes of defective vision.—32. Magnitude of the image on the retina.—33. Apparent magnitude defined.—34-37. Nature of its variation.—38-40. Diminutiveness of the pictures on the retina.—41. Sufficiency of illumination.

1. OF all the organs of sense, that to which we are most largely indebted is unquestionably **THE EYE**. It opens to us the widest and most varied range of observation. The pleasures and advantages we derive from it directly and indirectly have neither cessation nor bounds. It guides our steps through the world we

## THE EYE.

inhabit. It invests us with a space-penetrating power to which there seems to be no practical limit. By the exercise of this power, we enjoy the unspeakable pleasure of surveying the physical universe, consisting of countless myriads of worlds dispersed through the measureless abysses of space, worlds compared with most of which this of ours is of most diminutive dimensions. These stupendous globes roll in silent majesty round remote suns which warm and illuminate distant spheres, and collected in vast groups, are often presented to our eye as mere nebulous specks, but when viewed with high telescopic aid, blaze into stellar masses of the most dazzling splendour. System after system of worlds like our own are thus displayed before us, which, according to all analogy, are similarly peopled, and destined to fulfil like destinies in the moral economy of creations, theatres of life and intelligence teeming with evidence of the incessant play of boundless power, wisdom, and goodness.

Although the eye, strictly speaking, is cognisant only of light and colours, yet from an habitual comparison of combinations and tints of colour with the forms of bodies, as ascertained by the sense of touch, we are enabled, with the greatest facility, promptitude, and precision, to recognise by the sight, the forms, magnitudes, motions, distances, and positions, not only of the objects which surround us, and which we can approach, but also of those constituting the material universe, which are inaccessible.

This vast range of observation, however, great as it is, forms but a small part of the sources of pleasure and advantage supplied by this organ. We have, besides, the inestimable advantages and the great moral powers which arise from the ability it bestows upon us to acquire knowledge through the study of books. It enables us to converse with and derive instruction from the most learned, the most wise, and the most virtuous of our own and all former ages; and although those who have the misfortune to be deprived of this important organ, can, to some small extent, replace it by the ear, aided by the eye of another; yet this, and all other expedients contrived for their relief, supply results infinitely small and insignificant compared with those which are obtained by the organ itself.

2. The eye, considered in itself apart from its uses, is a most interesting and instructive object. It affords beyond comparison the most beautiful example of design, structure, and contrivance, that is to be found in the animal economy. Nowhere do we find so remarkable an adaptation of means to an end, of means consisting of the most profound combination of scientific principles, and an end manifesting the operation of a will directed by the most boundless beneficence.

## STRUCTURE OF THE EYE.

This organ is, for these reasons, a subject of inquiry and exposition, which must be regarded with the most lively interest by every one, whatever be his station, who is endowed with the least understanding or reflection. But besides the general considerations here developed, it is also to be remembered that, without a previous knowledge of the structure and functions of the eye, it is impossible to comprehend the use and application of the innumerable optical instruments which have been invented to aid its defects, whether natural or accidental; to repair the ravages of time, and to supply to age a renovated and re-invigorated organ of vision; to replace the diseased optical membrane removed by the knife of the surgeon, and thus restore sight where absolute blindness had ensued; to bring within the range of accurate vision objects rendered indistinctly visible, or altogether invisible, either by reason of their remoteness or minuteness. These admirable instruments can be easily rendered intelligible, provided a general knowledge of the structure and functions of the eye be first obtained, but not otherwise.

We purpose, therefore, to devote the present tract to a popular and simple exposition of the eye, and more particularly, the human eye.

3. The eyes, as they exist in the human species, have the form, as is well known, of two spheres, each about an inch in diameter, which are surrounded and protected by strong bony sockets placed on each side of the upper part of the nose. The external coating of these spheres is lubricated by a fluid secreted in adjacent glands, and spread upon them from time to time by the action of the eye-lids in winking.

The eye-balls are moved by muscles connected with them within the socket upon the principle known in mechanics as the ball and socket joint.

A front view of the eyes and surrounding parts is shown in fig. 1, a section of them made by a horizontal plane through the line A B, which passes through the centre of the front of the eye-balls, being shown in fig. 2 (see p. 49).

4. The external coating C D F E consists of a strong and tough membrane, called the *sclerotica*, or sclerotic coat. A part of this membrane is visible when the eye-lids are open at w, and is called the *white of the eye*. In this part of the eye-ball there is a circular opening, covered by a thin and perfectly transparent shell D G F, called the *cornea*. This cornea is more convex than the general surface of the eye-ball, and may be compared to a watch-glass. It is connected round its edge with the sclerotica, which differs from it, however, both in colour and opacity, the sclerotica being white and opaque, while the cornea is perfectly colourless

## THE EYE.

and transparent. The thickness of the cornea is everywhere the same.

The cornea covers that part of the front of the eye which is coloured, and is terminated round the coloured part at the commencement of the white of the eye.

5. Within the cornea is a small chamber filled with a transparent liquid, called the *aqueous humour*, partially divided by a thin annular partition *l*, called the *iris*, in the centre of which is a circular aperture *p*, called the *pupil*. The *iris* is a membranous substance varying in colour in different individuals, which gives the peculiar colour to the eye. The pupil presents the appearance of a black spot in the centre of the coloured part. A front view of the iris and pupil is given at *l* and *p*, and a section is indicated by the same letters in fig. 2.

6. The membrane containing the aqueous humour is terminated at its posterior part by a substance in the form of a double convex lens, which contains another transparent liquid, called the *crystalline humour*. This lens *κ* is somewhat greater in diameter than the pupil, and is supported by a ring of muscles, called the *ciliary processes* (represented at *l*), in such a position that its axis passes through the centre of the pupil.

Thus the crystalline and the ciliary processes, with the cornea, include the membrane containing the aqueous humour.

7. Within the sclerotica is a second coat *ν*, called the *choroid*. This is a vascular membrane which lines the internal surface of the sclerotic coat, and which terminates in front in the ciliary processes, by which the crystalline lens is set in it in the same manner as the cornea is set in the sclerotic coat.

Some anatomists maintain that the iris is only a continuation of the choroid, and that the cornea is a continuation of the sclerotic coat, which there becomes transparent. The inner surface of this choroid coat is covered with a slimy pigment of an intensely black colour, by which the reflection of the light which enters the eye is prevented.

8. A third coat, represented at *o*, called the *retina*, from the resemblance of its structure to network, lines this black coating.

The internal chamber *q* of the eye-ball is filled with a transparent liquor, called the *vitreous humour*, which is included in a membranous capsule, called the *hyaloid*.

Thus between the cornea and the posterior surface of the eye there are three successive humours; the aqueous, contained by the cornea; the crystalline, contained by the crystalline lens; and the vitreous, which fills the inner and larger chamber of the eye-ball.

9. A straight line *κ τ* passing through the centre of the cornea,

## STRUCTURE OF THE EYE.

coinciding with the axis of the crystalline lens, and through the centre of the eye-ball, is called the *optical axis*, or the *axis of the eye*.

At a point of the posterior surface of the eye-ball between the optical axis *M T* and the nose, the sclerotic coat is formed into a tube, which leads backwards and upwards to the brain. This tube contains within it the *optic nerve*, which at the point *C E*, where it enters the eye-ball, spreads out over the inner surface of the choroid and forms the retina, and includes the *hyaloid capsule* containing the vitreous humour.

The retina must therefore be regarded as nothing more than the continuation and diffusion of the optic nerve.

The retina, which in dissection admits of being easily separated from the choroid, is absolutely transparent, so that the light or colours which enter the inner chamber of the eye are not intercepted by it, but penetrate it as they would any other thin and perfectly transparent substance, and are only arrested by the black coating spread upon the choroid.

10. The following are the average numerical data connected with the eye :—

	100ths of an inch.
Radius of sclerotic coating . . . . .	39 to 43
Radius of cornea . . . . .	28 — 32
External diameter of iris . . . . .	43 — 47
Diameter of pupil . . . . .	12 — 28
Thickness of cornea . . . . .	4
Distance of pupil from centre of cornea . . . . .	8
Distance of pupil from centre of crystalline . . . . .	4
Radius of anterior surface of crystalline . . . . .	28 — 39
Radius of posterior surface of crystalline . . . . .	20 — 24
Diameter of crystalline . . . . .	39
Thickness of crystalline . . . . .	30
Length of optic axis . . . . .	87 — 95

11. The limits of the play of the eye-ball are as follows :—The optic axis can turn in the horizontal plane through an angle of 60° towards the nose, and 90° outwards, giving an entire horizontal play of 150°. In the vertical direction it is capable of turning through an angle of 50° upwards and 70° downwards, giving a total vertical play of 120°.

12. When an image of any object is formed by a lens composed of a single piece of glass or other transparent substance, it is always tinged more or less at its edges with the prismatic colours, giving it a sort of iridescence. This constituted a defect of the telescope, which seemed so irremediable that many astronomers had recourse by preference to reflectors, in which no such effect is produced. At length it was discovered that this defect could be completely



## THE EYE.

removed by lenses, composed of two species of glass, having different refracting powers, and whose curvatures are mutually adapted according to principles established in optics.

Now, it is a curious and highly interesting fact, that the eye, which, as we know, is entirely free from this defect, owes its perfection in this respect to the application of precisely the same optical principle in its structure, so that if the first inventors of the telescope had only thought of copying more closely the structure of the eye, they would have discovered sooner the principle of **ACHROMATISM**, the name given to this precious quality of lenses, from two Greek words, signifying the absence of colour.

13. The structure of the eye being thus understood, it will be easy to explain the effect produced within it by luminous or illuminated objects placed before it.

Let us suppose rays of light proceeding from any luminous object, such as the sun, incident upon that part of the eye-ball which is left uncovered by the open eye-lids.

Those rays which fall upon the white of the eye, *w*, fig. 1, render visible that part of the eye-ball. Those rays which fall upon the cornea pass through it. The exterior rays fall upon the iris, by which they are reflected, and render it visible. The internal rays pass through the pupil, are incident upon the crystalline, which, being transparent, is also penetrated by them, from which they pass through the vitreous humour, and finally reach the posterior surface of the inner part of the eye, where they penetrate the transparent retina, and are received by the black surface of the choroid, upon which they produce an illuminated spot.

The aqueous humour being more dense than the external air, and the surface of the cornea, which includes it, being convex, rays passing from the air into it will be rendered by a general law of optics more convergent, or less divergent.

In like manner, the anterior surface of the crystalline lens being convex, and that humour being more dense than the aqueous, a further convergent effect will be produced.

Again, the posterior surface of the crystalline being convex towards the vitreous humour, and this latter humour being less dense than the crystalline, another convergent effect will take place. These rays passing successively through these three humours, are rendered at each surface more and more convergent.

14. If an object be placed before the eye, pencils of rays will proceed from it, and penetrate the successive humours; and if these pencils be brought to a focus at the posterior surface, an inverted image of the object will be formed there, exactly as it would be formed by lenses composed of any transparent media

## IMAGES ON THE RETINA.

whose refracting powers would correspond with each of the humours.

15. That this phenomenon is actually produced, may be rendered experimentally manifest by taking the eye-ball of an ox recently killed, and dissecting the posterior part, so as to lay bare the choroid. If the eye thus prepared be fixed in an aperture in a screen, and a candle be placed before it at a distance of eighteen or twenty inches, an inverted image of the candle will be seen through the retina, as if it were produced upon ground glass or oiled paper.

16. It appears, then, that the immediate cause of vision, and the immediate object of perception, is the image thus produced by means of the refracting powers of the humours of the eye.

17. In order, therefore, to perfect vision, the following conditions must be fulfilled :—

1°. The image must be perfectly distinct.

2°. It must have sufficient magnitude.

3°. It must be sufficiently illuminated.

4°. It must continue on the retina for a sufficient length of time.

Let us examine the circumstances which affect these conditions.

18.—1°. **DISTINCTNESS OF THE IMAGE.**

The image formed on the retina will be distinct or not, according as the pencils of rays proceeding from each point of the object placed before the eye, are brought to an exact focus on the retina or not. If they be not brought to an exact focus on the retina, their focus will be a point beyond the retina, or within it. In either case, the rays proceeding from any part of the object, instead of forming a corresponding point on the retina, will form a spot of greater or less magnitude, according to the distance of the focus of the pencil from the retina, and the assemblage of such luminous spots will form a confused picture of the object. This deviation of the foci of the pencils from the retina is caused by the refracting powers of the eye being either too feeble or too strong. If the refracting powers be too feeble, the rays are intercepted by the retina before they are brought to a focus; if they be too strong, they are brought to a focus before they arrive at the retina.

19. The objects of vision may be distributed into two classes, in relation to the refracting powers of the eye: 1st, Those which are at so great a distance from the eye, that the pencils proceeding from them may be regarded as consisting of parallel rays; 2ndly, Those which are so near that their rays have sensible divergence.

## THE EYE.

It has been stated that the diameter of the pupil varies from  $\frac{1}{8}$  to  $\frac{1}{4}$  an inch in magnitude, the variation depending upon a power of dilatation and contraction with which the iris is endued. Taking that diameter at its greatest magnitude of a quarter of an inch, pencils proceeding from an object placed at the distance of three feet would have an extreme divergence amounting to less than half a degree; and if the pupil be in its most contracted state when its diameter is only the one-eighth of an inch, then the divergence of the pencils proceeding from such an object would amount to about fifteen minutes of a degree. It may therefore be concluded, that pencils proceeding from all objects more distant from the eye than two or three feet, may be regarded as consisting of parallel rays.

20. If the refracting power of the humours of the eye be so feeble that rays proceeding from such objects, and which enter the eye in parallel directions, are not rendered sufficiently convergent to come to a focus on the retina, or on the contrary, are so strong as to bring them to a focus before they arrive at the retina, the image produced upon the retina will be confused from the cause just explained.

21. The remedy for such a defect in vision is supplied by the properties of convex and concave lenses.

If the eye possess too little convergent power, a convergent or convex lens is placed before it, which, receiving the parallel pencils, renders them convergent when they enter the pupil, and this enables the eye to bring them to a focus on the retina, provided the power of the lens be equal to the deficient convergence of the eye.

If, on the other hand, the convergent power of the eye be too great, so that the parallel rays are brought to a focus before arriving at the retina, a divergent or concave lens is placed before the eye, by means of which parallel pencils are rendered divergent before they enter the pupil; and the power of the lens is so adapted to the convergent power of the eye, that the rays shall be brought to a focus on the retina.

The two opposite defects of vision here indicated are generally called, the one *weak-sightedness* or *far-sightedness*, and the other *near-sightedness*.

If the objects of vision be placed so near the eye that the rays composing the pencils which proceed from them have sensible divergence, then the foci of these rays within the eye will be at a distance from the optical centre greater than the principal focus, which is the name given to the focus of parallel rays. If, therefore, in this case, the principal focus fall upon the retina, the focus of rays proceeding from such near objects would fall

## FAR SIGHT AND NEAR SIGHT.

beyond it, and consequently the image on the retina would be indistinct.

22. It follows, therefore, that eyes which see distant objects at the greater class of distances would see indistinctly all objects at less distances, unless there were in the eye some means of self-adjustment, by which its convergent power may be augmented. Such means of self-adjustment are provided, which operate within certain limits, by which we are enabled so to accommodate the eye to the divergence of the pencils proceeding from near objects, that the same eyes which are capable of seeing distinctly objects so distant as to render the rays of the pencils sensibly parallel, are also capable of seeing with equal distinctness objects at distances varying from ten to twelve inches and upwards.

23. By what means the convergent power of the humours is thus varied is not certainly known, but that such means of self-adjustment exist may be proved by the following experiment :—

Let a small black spot be made upon a thin transparent plate of glass, and let it be placed at a distance of about twelve inches from the eye. If the eye be directed to it, the spot will be seen as well as distant objects visible through the glass. Let the attention be earnestly directed to the black spot, so that a distinct perception of its form may be produced. The objects visible at a distance will then be found to become indistinct.

But if the attention be directed more to the distant objects, so as to obtain a distinct perception of them, the perception of the black spot on the glass will then become indistinct. It is evident, therefore, that when the eye accommodates itself so as to form upon the retina a distinct image of an object at twelve inches distance, the image produced by objects at great distances will become indistinct; and that, on the other hand, when the eye so accommodates itself as to render the image produced on the retina by distant objects distinct, the image produced by an object at two inches distance will become indistinct.

24. It is evident, therefore, that the power of the eye to refract the pencils of light incident upon it, is to a certain extent under the control of the will; but by what means this change in the refracting power of the organ is made is not so apparent. Various hypotheses have been advanced to explain it. According to some, the form of the eye-ball, by a muscular action, is changed in such a manner as to increase the length of the optic axis, and thus to remove the posterior surface of the retina to a greater distance from the crystalline, when it is necessary to obtain a distinct view of near objects; and, on the contrary, to elongate the transverse diameter of the eye, and shorten the optic axis so

## THE EYE.

as to bring the retina closer to the crystalline, when it is desired to obtain a distinct view of distant objects.

According to others, this change of form is only effected in the cornea, which being rendered more or less convex by a muscular action gives a greater or less convergent power to the aqueous humour.

According to others, the eye accommodates itself to different distances by the action of the crystalline, which is moved by the ciliary processes either towards or from the cornea, thus transferring the focus of rays proceeding from it within a certain limit of distance to and from the retina; or, by a similar action of the ciliary processes, the crystalline lens may be supposed to be rendered more or less convex, and thus to increase or diminish its convergent power.

25. Whatever be the provisions made in the organisation of the eye, by which it is enabled to adapt itself to the reception of divergent pencils proceeding from near objects, the power with which it is thus endued has a certain limit. Thus eyes, which see distinctly distant objects, and which therefore bring parallel rays to a focus on the retina in their ordinary state, are not capable of seeing distinctly objects brought nearer to them than ten or twelve inches. The power of accommodating the vision to different rays is therefore limited to a divergence not exceeding that which is determined by the diameter of the pupil compared with a distance of ten or twelve inches. Now, as the diameter of the pupil is most contracted when the organ is directed to such near objects, we may assume it at its smallest magnitude at one-eighth of an inch, and therefore the divergence of a pencil proceeding from a distance of twelve inches would be  $\frac{1}{96}$ th, and the angle of divergence would therefore be very nearly half a degree.

It may, therefore, be assumed that eyes adapted to the vision of distant objects are in general incapable of seeing distinctly objects from which pencils have greater divergence than this, or which is the same, objects placed at less than ten or twelve inches from the eye.

26. In the case of eyes whose convergent power is too feeble to bring pencils proceeding from distant objects to a focus on the retina, they will be in a still greater degree inadequate to bring pencils to a focus which diverge from near objects; and consequently such eyes will require to be aided, for near as well as distant objects, by the interposition of convergent lenses. It would, however, be necessary to provide lenses of different convergent powers for distant and near objects, the latter requiring a greater convergent power than the former; and in general the nearer the objects viewed, the greater the convergent power required from the lens.

## SELF-ADJUSTMENTS OF THE EYE.

27. In the case of eyes whose convergent power is so great as to bring pencils proceeding from distant objects to a focus short of the retina, and which therefore, for such distant objects, require the intervention of divergent lenses, distinct vision will be attained without the interposition of any lens, provided the object be placed at such a distance that the divergence of the pencils proceeding from it shall be such that the convergent power of the eye bring them to a focus on the retina.

Hence it is that eyes of this sort are called *short-sighted*, because they can see distinctly such objects only as are placed at the distance which gives the pencils proceeding from them such a divergence, that the convergent power of the eye would bring them to a focus on the retina.

28. If it be desired to ascertain the focal length of the divergent lens which such an eye would require to see distant objects distinctly, it is only necessary to ascertain at what distance it is enabled to see distinctly the same class of objects without the aid of a lens. A lens having a focal length equal to this distance will enable the eye to see distant objects distinctly, because such a lens would give the parallel rays a divergence equal to the divergence of pencils proceeding from a distance equal to its focal length.

29. Persons are said to be more or less near-sighted, according to the distance at which they are enabled to see objects with perfect distinctness, and they accordingly require, to enable them to see distant objects distinctly, diverging lenses of greater or less focal length.

As persons who are enabled to see distant objects distinctly have the power of accommodating the eye so as to see objects at ten or twelve inches' distance, so short-sighted persons have a similar power of accommodation, but within proportionally smaller limits. Thus a short-sighted person will be enabled to see distinctly objects placed at distances from the eye varying from four or five inches upwards, according to the degree of short-sightedness with which he is affected.

30. The two opposite defects of vision which have been mentioned, arising from too great or too little convergent power in the eye, may arise, either from a defect in the quality of the humours or in the form of the eye. Thus near-sightedness may arise from too great convexity in the cornea or in the crystalline, or it may arise from too great a difference of density between the aqueous humour and the crystalline, or between the crystalline humour and the vitreous, or both of them; or, in fine, it may arise from defects both of the form and of the relative densities of the humours.

31. In a certain class of maladies incidental to the sight, the humours of the eye lose in a greater or less degree their trans-

## THE EYE.

parency, and the crystalline humour is more especially liable to this. In such cases vision is sometimes recovered by means of the removal of the crystalline humour, in which case the organ is reduced to two humours, the aqueous and the vitreous; but as the eye owes in a greater degree to the crystalline than to the other humours the convergent power, it is necessary in this case to supply the place of the crystalline by a very strong convergent lens placed before the eye.

### 32.—2°. MAGNITUDE OF THE IMAGE ON THE RETINA.

In order to obtain a perception of any visible object, it is not enough that the image on the retina be distinct, it must also have a certain magnitude.

Let us suppose that a white circular disk, one foot diameter, is placed before the eye at a distance of  $57\frac{1}{2}$  feet.

The axes of the pencils of rays proceeding from such disk to the eye will be included within a cone, whose base is the disk, and whose vertex is in the centre of the eye.

These axes, after intersecting at the centre of the eye, will form another cone, whose base will be the image of the disk formed upon the retina. The common angle of the two cones will in this case be  $1^\circ$ .

Let  $A B$  (fig. 3), be the diameter of the disk. Let  $c$  be the centre of the eye, and let  $b a$  be the diameter of the image on the

Fig. 3.

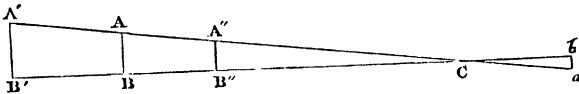

retina. It is clear, from the perfect similarity of the triangles  $A C B$  and  $a c b$ , that the diameter of the image  $b a$  will have to the diameter of the object  $B A$  the same proportion as the distance  $a c$  of the retina from the centre  $c$  has to the distance  $A c$  of the object from the same centre. Therefore in this case, since one-half the diameter of the eye is but half an inch, and the distance  $A c$  is in this case supposed to be  $57\frac{1}{2}$  feet, the magnitude of the diameter  $b a$  of the image on the retina will be found by the following proportion:—

$$a b : A B :: \frac{1}{2} : 57\frac{1}{2} \times 12 = 690,$$

Therefore we have

$$a b = \frac{\frac{1}{2} \times A B}{690} = \frac{6}{690} = \frac{1}{115}.$$

The total magnitude, therefore, of the diameter of the image on

## MAGNITUDE OF THE IMAGE.

the retina would in this case be the  $\frac{1}{115}$ th part of an inch; yet such is the exquisite sensibility of the organ, that the object is in this case distinctly visible.

If the disk were removed to twice the distance here supposed, the angle of the cone  $c$  would be reduced to half a degree, and the diameter of the image on the retina would be reduced to one-half its former magnitude, that is to say, to the  $\frac{1}{230}$ th part of an inch. If, on the other hand, the disk were moved towards the eye, and placed at half its original distance, then the angle  $c$  of the cone would be  $2^\circ$ , and the diameter of the picture on the retina would be double its first magnitude, that is to say, the  $\frac{2}{115}$ th of an inch.

In general, it may therefore be inferred that the magnitude of the diameter of the picture on the retina is increased or diminished in exactly the same proportion as the angle of the cone  $c$ , formed at the centre of the eye, is increased or diminished.

33. This angle is called the visual angle or apparent magnitude of the object; and when it is said that a certain object subtends at the eye a certain angle, it is meant that lines drawn from the extremities of such object to the centre of the eye form such angle.

The *apparent magnitude* of an object must not be confounded with its apparent superficial magnitude, the term being invariably applied to its *linear magnitude*. The apparent superficial magnitude varies in proportion to the square of the apparent magnitude.

Thus, for example, when the disk  $A B$  is removed to double its original distance from the eye, the apparent magnitude, or the angle  $c$ , is diminished one-half, and consequently the diameter  $a b$  of the picture on the retina is also diminished one-half; and since the diameter is diminished in the ratio of 2 to 1, the superficial magnitude of the image, or its area, will be diminished in the proportion of 4 to 1.

34. It is clear from what has been stated also, that when the same object is moved from or towards the eye, its apparent magnitude varies inversely as its distance; that is, its apparent magnitude is increased in the same proportion as its distance is diminished, and *vice versa*.

It is easy to perceive that the objects which are seen under the same visual angle will have the same apparent magnitude. Thus let  $A' B'$  (fig. 3), be an object more distant than  $A B$ , and of such a magnitude that its highest point  $A'$  shall be in the continuation of the line  $c A$ , and its lowest point  $B'$  in the continuation of the line  $c B$ . The apparent magnitude of  $A' B'$  will then be measured by the angle at  $c$ . This angle will therefore at the same time represent the apparent magnitude of the object  $A B$  and of the object  $A' B'$ . It is evident that an eye placed at  $c$  will see every point of the object  $A B$  upon the corresponding points of the object



## THE EYE.

$A' B'$ ; so that if the object  $A B$  were opaque, and of a form similar to the object  $A' B'$ , every point of the one would be seen upon a corresponding point of the other. In like manner, if an object  $A'' B''$  were placed nearer the eye than  $A B$ , so that its highest point may lie upon the line  $C A$ , and its lowest point upon the line  $C B$ , the object being similar in form to  $A B$ , would appear to be of the same magnitude. Now it is evident that the real magnitudes of the three objects  $A'' B''$ ,  $A B$ , and  $A' B'$ , are in proportion to their respective distances from the eye;  $A' B'$  is just so much greater than  $A B$ , and  $A B$  than  $A'' B''$ , as  $C B'$  is greater than  $C B$ , and as  $C B$  is greater than  $C B''$ .

Thus it appears that if several objects be placed before the eye in the same direction at different distances, and that the real linear magnitudes of these objects are in the proportion of their distances, they will have the same apparent magnitude.

35. A striking example of this principle is presented by the case of the sun and moon. These objects appear in the heavens equal in size, the full moon being equal in apparent magnitude to the sun. Now it is proved by astronomical observation that the real diameter of the sun is, in round numbers, four hundred times that of the moon; but it is also proved that the distance of the sun from the earth is also, in round numbers, four hundred times greater than that of the moon. The distances, therefore, of these two objects being in the same proportion as their real diameters, their visual or apparent magnitudes are equal.

36. It is evident from what has been explained, that objects which have equal apparent magnitudes, and are therefore seen under equal visual angles, will have pictures of equal magnitude on the retina, a fact which proves that the visual angle is the measure of the apparent magnitude.

37. If the same object be moved successively to increasing distances, its apparent magnitude will be diminished in the same proportion, exactly as its distance from the eye is increased. Thus, if  $L M$  (fig. 4), be such an object, its apparent magnitude at

Fig. 4.

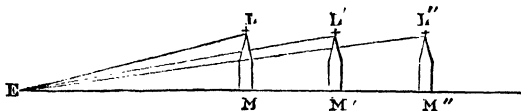

the distance  $E M$  will be measured by the angle  $L E M$ , at the distance  $E M'$  by the angle  $L' E M'$ , and at the distance  $E M''$  by the angle  $L'' E M''$ ; and when the actual magnitude  $L M$  bears a

## APPARENT MAGNITUDE.

small proportion to the distance, it is shown by the principles of geometry that the angle  $L'EM'$  is less than the angle  $LEM$  in the same proportion as  $EM'$  is greater than  $EM$ , and that the angle  $L''EM''$  is less than  $LEM$  in the same proportion as  $EM''$  is greater than  $EM$ .

38. Nothing can be more calculated to excite our wonder and admiration than the distinctness of our perception of visible objects, compared with the magnitude of the picture on the retina, from which immediately we receive such perception.

39. If we look at the full moon on a clear night, we perceive with considerable distinctness by the naked eye the lineaments of light and shade which characterise its disk. Now let us consider only for a moment what are the dimensions of the picture of the moon formed on the retina, from which alone we derive this distinct perception.

The disk of the moon subtends a visual angle of half a degree, and consequently, according to what has been explained, the diameter of its picture on the retina will be  $\frac{1}{30}$ th part of an inch, and the entire superficial magnitude of the image from which we derive this distinct perception is only the  $\frac{1}{5200}$ th part of a square inch; yet within this minute space, we are able to distinguish a multiplicity of still more minute details. We perceive, for example, forms of light and shade, whose linear dimensions do not exceed one-tenth part of the apparent diameter of the moon, and which therefore occupy upon the retina a space whose diameter does not exceed the  $\frac{1}{500000}$ th part of a square inch.

40. To take another example, the figure of a man 70 inches high, seen at a distance of 40 feet, produces an image upon the retina the height of which is about one-fourteenth part of an inch. The face of such an image is included in a circle whose diameter is about one-twelfth of the height, and therefore occupies on the retina a circle whose diameter is about the  $\frac{1}{170}$ th part of an inch; nevertheless, within this circle, the eyes, nose, and lineaments are distinctly seen. The diameter of the eye is about one-twelfth of that of the face, and therefore, though distinctly seen, does not occupy upon the retina a space exceeding the  $\frac{1}{300000}$ th of a square inch.

If the retina be the canvas on which this exquisite miniature is delineated, how infinitely delicate must be its structure, to receive and transmit details so minute with such marvellous precision; and if, according to the opinion of some, the perception of these details be obtained by the retina *feeling* the image formed upon the choroid, how exquisitely sensitive must be its touch!

### 41.—3°. SUFFICIENCY OF ILLUMINATION.

It is not enough for distinct vision that a well-defined picture of

## THE EYE.

the object shall be formed on the retina. This picture must be sufficiently illuminated to affect the sense, and at the same time not be so intensely illuminated as to overpower the organ.

Thus it is possible to conceive a picture on the retina so extremely faint as to be insufficient to produce sensation, or, on the other hand, so intensely brilliant as to dazzle the eye, to destroy the distinctness of sense, and to produce pain.

When we direct the eye to the sun, near the meridian, in an unclouded sky, we have no distinct perception of his disk, because the splendour is so great as to overpower the sense of vision, just as sounds are sometimes so intense as to be deafening.

That it is the intense splendour alone which prevents a distinct perception of the solar disk in this case is rendered manifest by the fact that if a portion of the solar rays be intercepted by a coloured glass, or by a thin cloud, a distinct image of the sun will be seen.

When we direct the eye to the firmament on a clear night, there are innumerable stars which transmit light to the eye, and which therefore must produce some image on the retina, but of which we are altogether insensible, owing to the faintness of the illumination. That the light, however, does enter the eye and arrive at the retina is proved by the fact that if a telescope be directed to the stars in question, so as to collect a greater quantity of their light upon the retina, they will become visible.

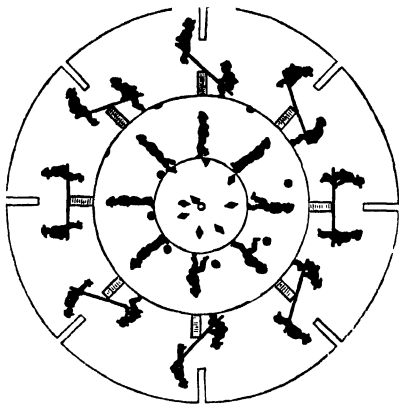

Fig. 8.—THE THAUMATROPE.

## THE EYE.

### CHAPTER II.

42. Power of accommodation of the eye.—43, 44. Apparent brightness of luminous objects.—45-47. Intensity of brightness.—48-57. The image must continue a sufficient time upon the retina to enable that membrane to produce a perception of it—Various illustrations of this.—58. Conditions which determine; apparent motion.—59. How affected by distance.—60. Example.—61. When imperceptible.—62. Motion of the firmament.—63. Objects in rapid motion invisible.—64-66. Duration of the impression on the retina.—67. Optical toys.—68, 69. Coincidence of the optical and geometrical centres of the eye.—70. Ocular spectra and accidental colours.—71. Why visible objects do not appear inverted.—72. The seat of vision.—73-75. The optic nerve insensible to light.

42. THE eye possesses a certain limited power of accommodating itself to various degrees of illumination. Circumstances which are familiar to every one render the exercise of this power evident.

If a person, after remaining a certain time in a dark room, pass suddenly into another room strongly illuminated, the eye suffers instantly a degree of inconvenience, and even pain, which

causes the eyelids to close; and it is not until after the lapse of a certain time that they can be opened without inconvenience.

The cause of this is easily explained. While the observer remains in the darkened or less illuminated room, the pupil is dilated so as to admit into the eye as great a quantity of light as the structure of the organ allows of. When he passes suddenly into the strongly illuminated room, the flood of light arriving through the widely dilated pupil acts with such violence on the retina as to produce pain, which necessarily calls for the relief and protection of the organ. The iris, then, by an action peculiar to it, contracts the dimensions of the pupil so as to admit proportionally less light, and the eye is opened with impunity.

Effects the reverse of these are observed when a person passes from a strongly illuminated room into one comparatively dark, or into the open air at night. For a certain time he sees nothing, because the contraction of the pupil, which was adapted to the strong light to which it had previously been exposed, admits so little light to the retina that no sensation is produced. The pupil, however, after a while dilates, and, admitting more light, objects are perceived which were before invisible.

43. It is sometimes inferred, though erroneously, that the apparent splendour of the image of a visible object decreases as the square of the distance increases. This would be the case in the strictest sense, if, while the object were withdrawn from the eye to an increased distance, its image on the retina continued to have the same magnitude; for, in this case, the absolute brightness of each point composing such image would diminish as the square of the distance increases, and the area of the retina over which such points are diffused would remain the same; but it must be considered, that as the object retires from the eye the superficial magnitude of the image on the retina is diminished in the same proportion as the square of the distance of the object from the eye is increased. It therefore follows that while the points composing the image on the retina are diminished in the intensity of their illumination, they are collected into a smaller space, so that what each point of the image on the retina loses in splendour, the entire image gains by concentration.

44. If the sun were brought as close to the earth as the moon, its apparent diameter would be 400 times greater, and the area of its apparent disk 160000 times greater than at present, but the apparent brightness of its surface would not be in any degree increased. In the same manner, if the sun were removed to ten times its present distance, it would appear under a visual angle ten times less than at present, as in fact it would to an observer

## BRIGHTNESS OF THE IMAGE.

on the planet Saturn; and its visible area would be a hundred times less than it is, but the splendour of its diminished area would be exactly the same as the present splendour of the sun's disk.

The sun seen from the planet Saturn has an apparent diameter ten times less than it has when seen from the earth.

The appearance from Saturn will then be the same as would be the appearance of a portion of the disk of the sun seen from the earth through a circular aperture in an opaque plate, which would exhibit a portion of the disk whose diameter is one-tenth of the whole.

45. When the light which radiates from a luminous object has a certain intensity, it will continue to affect the retina in a sensible manner, even when the object is removed to such a distance that the visual angle shall cease to have any perceivable magnitude. The fixed stars present innumerable examples of this effect. None of these objects, even the most brilliant of them, subtend any sensible angle to the eye. When viewed through the most perfect telescopes they appear merely as brilliant points. In this case, therefore, the eye is affected by the light alone, and not by the magnitude of the object seen.

46. Nevertheless the distance of such an object may be increased to such an extent that the light, intense as it is, will cease to produce a sensible effect upon the retina.

There are seven classes of the fixed stars, diminishing gradually in brightness,\* which produce an effect on the retina such as to render them visible to the naked eye. This diminution of splendour is produced by their increased distance. The telescope brings into view innumerable other stars, whose intrinsic splendour is as great as the brightest among those which we see, but which do not transmit to the retina, without the aid of the telescope, enough of light to produce any sensible effect. It is demonstrable, however, that, even without the telescope, they do transmit a certain definite quantity of light to the retina; the quantity of light which they thus transmit, and which is insufficient to produce a sensible effect, having to the quantity obtained by the telescope a ratio depending upon the proportion of the magnitude of the object-glass of the telescope to the magnitude of the pupil.

47. The quantity and intensity of the light transmitted by an external object to the retina, which is sufficient to produce a perception of such object, depends also upon the light received at the

\* The term magnitude is used in astronomy, as applied to the fixed stars, to express their apparent brightness; no fixed star, however splendid, subtends any sensible angle.

## THE EYE.

same time by the retina from other objects present before the eye. The proof of this is, that the same objects which are visible at one time are not visible at another, though equally before the eye, and transmitting equal quantities of light of the same intensity to the retina. Thus, the stars are present in the heavens by day as well as by night, and transmit the same quantity of light to the retina, yet they are not visible in the presence of the sun, because the light proceeding from that luminary, directly and indirectly reflected and refracted by the air and innumerable other objects, is so much greater in quantity and intensity as to overpower the inferior and much less intense light of the stars. This case is altogether analogous to that of the ear, which when under the impression of loud and intense sounds, is incapable of perceiving sounds of less intensity, which nevertheless affect the organ in the same manner as they do when, in the absence of louder sounds, they are distinctly heard.

Even when an object is perceived, the intensity of the perception is relative, and determined by other perceptions produced at the same time. Thus, the moon seen at night is incomparably more splendid than the same moon seen by day or in the twilight, although in each case the moon transmits precisely the same quantity of light, of precisely the same intensity, to the eye; but in the one case the eye is overpowered by the superior splendour of the light of day, which dims the comparatively less intense light proceeding from the moon.

48.—4°. THE IMAGE MUST CONTINUE A SUFFICIENT TIME UPON THE RETINA TO ENABLE THAT MEMBRANE TO PRODUCE A PERCEPTION OF IT.

The velocity with which light is propagated through space is at the rate of about 200000 miles per second. Its transmission, therefore, from all objects at ordinary distances to the eye may be considered as instantaneous. The moment, therefore, any object is placed before the eye an image of it is formed on the retina, and this image continues there until the object is removed. Now it is easy to show experimentally that an object may be placed before the eye for a certain definite interval of time, and that a picture may be painted upon the retina during that interval without producing any perception or any consciousness of the presence of the object.

To illustrate this, let a circular disk  $A B C D$ , fig. 5, about twenty inches in diameter, be formed in card or tin, and let a circle  $A' B' C' D'$  be described upon it, about two inches less in radius than the disk, so as to leave between the circle and the disk a zone about two inches wide. Let the entire zone be blackened, except the space  $A M M' A'$ , forming about the one-twentieth of it.

## CONTINUANCE OF THE IMAGE.

Let the disk thus prepared be attached to the back of a blackened screen, so as to be capable of revolving behind it, and let a hole one inch in diameter be made in the screen at any point, behind which the zone  $A B C D$  is placed. If the disk be now made to revolve behind the screen, the hole will appear as a circular white spot so long as the white space  $A M$  passes behind it, and will disappear, leaving the same black colour as the screen during the remainder of the revolution of the disk. The hole will therefore be

Fig. 5.

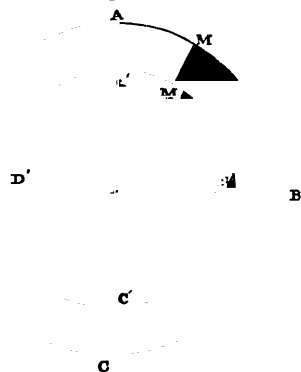

seen as a white circular spot upon the black screen during one-twentieth of each revolution of the disk. If the disk be now put in motion at a slow rate, the white hole will be seen on the screen during one-twentieth of each revolution. If the velocity of rotation imparted to the disk be gradually increased, the white spot will ultimately *disappear*, and the screen appear of a uniform black colour, although it be certain that during the twentieth part of each revolution, whatever be the rate of rotation, a picture of the white spot is formed on the retina.

49. The length of time necessary in this case for the action of light upon the retina to produce sensation may be determined by ascertaining the most rapid motion of the disk which is capable of producing a distinct perception of the white spot. This interval will be found to vary with the degree of illumination. If the spot be strongly illuminated, a less interval will be sufficient to produce a perception of it; if it be more feebly illuminated, a longer interval will be required. The experiment may be made by varying the colour of the space  $AM$  of the zone, and it will be found that the interval necessary to produce sensation will vary with the colour as well as with the degree of illumination.

50. Numerous observations on the most familiar effects of vision, and various experiments expressly contrived for the purpose, show that the retina, when once impressed with the picture of an object placed before the eye, retains this impression, sometimes with its full intensity and sometimes more faintly, just as the ear retains for a time the sensation of a sound after the cause which has put the tympanum in vibration has ceased to act. The



## THE EYE.

duration of this impression on the retina, after the removal of the visible object which produced it, varies according to the degree of illumination and the colour of the object. The more intense the illumination, and the brighter the colour, the longer will be the interval during which the retina will retain their effects.

51. To illustrate this experimentally, let a circular disk formed of blackened card or tin, of twelve or fourteen inches in diameter, be pierced with eight holes round its circumference, at equal distances, each hole being about half an inch in diameter, as represented in fig. 6.

Let this disk be attached upon a pivot or pin at its centre *o* to a board *A B C D*, which is blackened everywhere, except upon a circular spot at *v*, corresponding in magnitude to the holes made in the circular plate.

Let this spot be first supposed to be white. Let the circular disk be made to revolve upon the point *o*, so as to bring the circular holes successively before the white spot at *v*. The retina will thus be impressed at intervals with the image of this circular white spot. In the intervals between the transits of the holes over it, the entire board will appear black, and the retina will receive no impression. If the disk be made to revolve with a very slow motion, the eye will see the white spot at intervals,

Fig. 6.

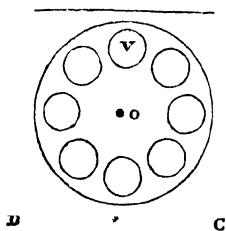

but if the velocity of rotation be gradually increased, it will be found that the eye will perceive the white spot permanently represented at *v*, as if the disk had been placed with one of its holes opposite to it without moving. It is evident, therefore, that in this case the impression produced upon the retina, when any hole is opposite the white spot, remains until the succeeding hole comes opposite to it, and thus a continued perception of the white spot is produced.

If the white spot be illuminated in various degrees, or if it be differently coloured, the velocity of the disk necessary to produce a continuous perception of it will differ. The brighter the colour and the stronger the illumination, the less will be the velocity of rotation of the disk which is necessary to produce a continuous perception of the spot.

These effects show that the stronger the illumination and the brighter the colour, the longer is the interval during which the impression is retained by the retina.

52. This continuance of the impression of external objects on the

## PERCEPTION OF A MOVING OBJECT.

retina, after the light from the object ceases to act, is also manifested by the fact, that the continual winking of the eyes for the purpose of lubricating the eye-ball by the eye-lid does not intercept our vision. If we look at any external objects, they never cease for a moment to be visible to us, notwithstanding the frequent intermissions which take place in the action of light upon the retina in consequence of its being thus intercepted by the eye-lid.

53. If a lighted stick be turned round in a circle in a dark room, the appearance to the eye will be a continuous circle of light; for in this case the impression produced upon the retina by the light, when the stick is at any point of the circle, is retained until the stick returns to that point.

54. In the same manner, a flash of lightning appears to the eye as a continuous line of light, because the light emitted at any point of the line remains upon the retina until the cause of the light passes over the succeeding points. In the same manner, any objects moving before the eye with such a velocity that the retina shall retain the impression produced at one point in the line of its motion until it passes through the other points, will appear as a continuous line of light or colour.

55. But to produce this effect, it is not enough that the body change its position so rapidly that the impression produced at one point of its path continues until its arrival at another point; it is necessary, also, that its motion should not be so rapid as to make it pass from any of the positions which it successively assumes before it has time to impress the eye with a perception of it; for it must be remembered, as has been already explained, that the perception of a visible object presented to the eye, though rapid, is not instantaneous.

The object must remain present before the organ of vision a certain definite time, and its position must continue upon the retina during such time, before any perception of it is obtained. Now, if the body move from its position before the lapse of this time, it necessarily follows that no perception of its presence, therefore, will be obtained. If, then, we suppose a body moving so rapidly before the eye that it remains in no position long enough to produce a perception of it, such object will not be seen.

56. Hence it is that the ball discharged from a cannon passing transversely to the line of vision is not seen; but if the eye be placed in the direction in which the ball moves, so that its angular motion round the eye as a centre will be slow notwithstanding its great velocity, it will be visible, because, however rapid its real motion through space, its angular motion with respect to the eye (and consequently of the image of its picture on the retina) will

## THE EYE.

be sufficiently slow to give the necessary time for the production of a perception of it.

57. The time thus necessary to obtain the perception of a visible object varies with the degree of illumination, the colour, and the apparent magnitude of the object. The more intense the illumination the more vivid the colour, and the greater the apparent magnitude the less will be the time necessary to produce a perception of the object.

58. In applying this principle to the phenomena of vision, it must be carefully remembered that the question is affected, not by the real but by the apparent motion of the object, that is to say, not by the velocity with which the object really moves through space, but by the angle which the line drawn from the eye to the object describes per second. Now this angle is affected by two conditions, which it is important to attend to: 1°. the direction of the motion of the object compared with the line of vision; and 2°. by the velocity of the motion compared with the distance of the object. If the object were to move exactly in the direction of the line of vision, it would appear to the eye to be absolutely stationary, since the line drawn to it would have no angular motion; and if it were to move in a direction forming an oblique angle to the line of vision, its apparent motion might be indefinitely slow, however great its real velocity might be.

For example, let it be supposed that the eye being at E, fig. 7, an object o moves in the direction of o o', so as to move from o to

Fig. 7.

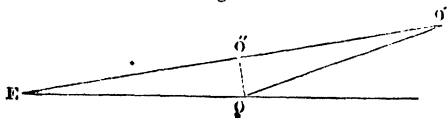

o' in one second. Taking E as a centre, and E o as a radius, let a circular arc o o'' be described. The apparent motion of the object will then be same as if, instead of moving from o to o' in one second, it moved from o to o'' in one second.

The more nearly, therefore, at right angles to the line of vision the direction of the motion is, the greater will be the apparent motion produced by any real motion of an object.

59. A motion which is visible at one distance may be invisible at another, inasmuch as the angular velocity will be increased as the distance is diminished.

Thus if an object at a distance of  $57\frac{1}{2}$  feet from the eye move at the rate of a foot per second, it will appear to move at the rate of one degree per second, inasmuch as a line one foot long at  $57\frac{1}{2}$

## PERCEPTION OF A MOVING OBJECT.

feet distance subtends an angle of one degree. Now if the eye be removed from such an object to a distance of 115 feet, the apparent motion will be half a degree, or thirty minutes per second; and if it be removed to thirty times that distance, the apparent motion will be thirty times slower. Or if, on the other hand, the eye be brought nearer to the object, the apparent motion will be accelerated in exactly the same proportion as the distance of the eye is diminished.

60. A cannon-ball moving at 1000 miles an hour transversely to the line of vision, and at a distance of 50 yards from the eye, will be invisible, since it will not remain a sufficient time in any one position to produce perception. The moon, however, moving with more than double the velocity of the cannon-ball, being at a distance of 240000 miles, has an apparent motion, so slow as to be imperceptible.

61. The angular motion of the line of vision may be so diminished as to become imperceptible; and the body thus moved will in this case appear stationary. It is found by experience that unless a body move in such a manner that the line of vision shall describe at least one degree in each minute of time, its motion will not be perceptible.

62. Thus it is that we are not conscious of the diurnal motion of the firmament. If we look at the moon and stars on a clear night, they appear to the eye to be quiescent; but if we observe them after the lapse of some hours, we find that their positions are changed, those which were near the horizon being nearer the meridian, and those which were in the meridian having descended towards the horizon. Since we are conscious that this change did not take place suddenly, we infer that the entire firmament must have been in continual motion round us, but that this motion is so slow as to be imperceptible.

Since the heavens appear to make a complete revolution in twenty-four hours, each object on the firmament must move at the rate of  $15^{\circ}$  an hour, or at the rate of one quarter of a degree a minute. But since no motion is perceptible to the eye which has a less apparent velocity than  $1^{\circ}$  per minute, this motion of the firmament is unperceived. If, however, the earth revolved on its axis in six hours instead of twenty-four hours, then the sun, moon, stars, and other celestial objects, would have a motion at the rate of  $60^{\circ}$  an hour, or  $1^{\circ}$  per minute. The sun would appear to move over a space equal to twice its own diameter each minute, and this motion would be distinctly perceived.

The fact that the motion of the hands of a clock is not perceived is explained in the same manner.

63. If an object which moves very rapidly be not sufficiently

## THE EYE.

illuminated, or be not of a sufficiently bright colour to impress the retina sensibly, it will then, instead of appearing as a continuous line of colour, cease to be visible altogether; for it does not remain in any one position long enough to produce a sensible effect upon the retina. It is for this reason that a ball projected from a cannon or a musket, though passing before the eye, cannot be seen. If two railway trains pass each other with a certain velocity, a person looking out of the window of one of them will be unable to see the other. If the velocity be very moderate, and the light of the day sufficiently strong, the appearance of the passing train will be that of a flash of colour formed by the mixture of the prevailing colours of the vehicles composing it.

An expedient has been contrived, depending on this principle, to show experimentally that the mixture of the seven prismatic colours, in their proper proportions, produces white light. The colours are laid upon a circular disk surrounding its edge, which they divide into parts proportional to the spaces they occupy in the spectrum. When the disk is made to revolve, each colour produces, like the lighted stick, the impression of a continuous ring, and consequently the eye is sensible of seven rings of the several colours superposed one upon the other, which thus produce the effect of their combination, and appear as white or a whitish grey colour.

64. The duration of the impression upon the retina, after the object producing it is removed, varies according to the vividness of the light proceeding from the object, being longer according as the light is more intense. It was found that the light proceeding from a piece of coal in combustion moved in a circle at a distance of 165 feet, produced the impression of a continuous circle of light when it revolved at the rate of seven times per second. The inference from this would be that in that particular case the impression upon the retina was continued during the seventh part of a second after the removal of the object.

It is from the cause here indicated that forked lightning presents the appearance of a continuous line of light.

65. The duration of the impression on the retina varies also with the colour of the light, that produced by a white object being most visible, and yellow and red being most in degree of durability; the least durable being those tints which belong to the most refrangible lights.

66. The duration of the impression also depends on the state of illumination of the surrounding space; thus the impression produced by a luminous object when in a dark room is more durable than that which would be produced by the same object seen in an illuminated room. This may be ascribed to the greater sensitiveness

## THAUMATROPES.

of the retina when in a state of repose than when its entire surface is excited by surrounding lights. Thus it is found that while the varying duration of the impression of the illuminated object in a dark room was one-third of a second, its duration in a lighted room was only one-sixth of a second.

67. Innumerable optical toys and pyrotechnic apparatus owe their effect to this continuance of the impression upon the retina when the object has changed its position.

Amusing toys, called thaumatropes, phenakisticopes, phantaskopes, &c., are explained upon this principle. A moving object, which assumes a succession of different positions in performing any action, is represented in the successive divisions of the circumference of a circle, as in fig. 8, in the successive positions it assumes. These pictures, by causing the disk to revolve, are brought in rapid succession before an aperture, through which the eye is directed, so that the pictures representing the successive attitudes are brought one after another before the eye at intervals; the impression of one remaining until the impression of the next is produced. In this manner the eye never ceases to see the figure, but sees it in such a succession of attitudes as it would assume if it revolved. The effect is, that the figure actually appears to pirouette before the eye. The effects of catherine-wheels and rockets are explained in the same manner.

68. The direction in which any part of an object is seen is that of the line drawn from such point through the optical centre of the eye. This line being carried back to the retina determines the place on the retina where the image of such point is found. If the optical centre of the eye were not at the centre of the eye-ball, the direction of this line would be changed with every movement of the eye-ball in its socket; every such movement would cause the optical centre to revolve round the centre of the eye-ball, and consequently would cause the line drawn from the optical centre to the object to change its direction. The effect of this would be that every movement of the eye-ball would cause an apparent movement of all visible objects. Now, since there is no apparent motion of this kind, and since the apparent position of external objects remains the same, however the eye may be moved in its socket, it follows that its optical centre must be at the centre of the eye-ball.

69. Since lines drawn from the various points of a visible object through the centre of the eye remain unchanged, however the eye-ball may move in its socket, and since the corresponding points of the image placed upon these lines must also remain unchanged, it follows that the position of the image formed on the eye remains fixed, even though the eye-ball revolve in the

## THE EYE.

socket. It appears, therefore, that when the eye-ball is moved in the socket, the picture of an external object remains fixed, while the retina moves under it, just as the picture thrown by a magic lantern on a screen would remain fixed, however the screen itself might be moved.

Thus, if we direct the axis of the eye to the centre  $o$ , fig. 9, of any object, such as  $A B$ , the image of the point  $o$  will be formed at  $o$  on the retina, where the optical axis  $D C$  meets it. The axis of the pencil of rays which proceed from the point  $o$  will pass through the centre of the cornea  $D$ , through the axis of the crystalline, and through the centre  $C$  of the eye-ball, and the image of  $o$  will be formed at  $o$ .

Now, if we suppose the eye to be turned a little to the left, so

Fig. 9.

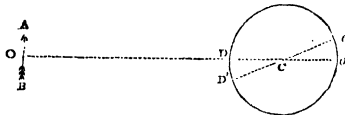

that the optical axis will be inclined to the line  $o C$  at the angle  $D' c o$ , the image of the point  $o$  will still hold the same absolute position  $o$  as before; but the point of the retina on which it was previously formed will be removed to  $o'$ . The direction of the point  $o$  will be the same as before; but the point of the retina on which its image will be formed will be, not at  $o$ , at the extremity of the optic axis, but at  $o'$ , at a distance  $o o'$  from it, which subtends at the centre  $C$  of the eye an angle equal to that through which the optical axis has been turned.

It is evident, therefore, that although the eye in this case be moved round its centre, the point  $o$  is still seen in the same direction as before.

But if the optical centre of the eye were different from the centre of the eye-ball, the direction in which the point  $o$  would be seen would be changed by a change of position of the eye.

To render this more clear, let  $c$ , fig. 10, be the centre of the

Fig. 10.

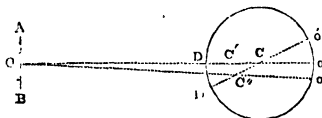

eye-ball, and  $c'$  the optical centre of the eye. Let the optical axis  $c D$ , as before, be first presented to the point  $o$  of the object.

## OCULAR SPECTRA.

The image of this point will, as before, be formed at  $o$ , the point where the optical axis  $D C$  meets the retina. Let us now suppose the axis of the eye to be turned aside through the angle  $D C D'$ , the optical centre will then be removed from  $c'$  to  $c''$ , and the image of  $o$  will now be formed at the point  $o''$ , where the line  $o c''$  meets the retina. The direction, therefore, in which  $o$  will now be seen, will be that of the line  $c'' o$ , whereas the direction in which it was before seen was that of the line  $c o$ . The point of the retina at which the image  $o$  was originally formed is removed to  $o'$ , while the image is removed to  $o''$ . Thus there is a displacement not only of the retina behind the image, but also an absolute displacement of the image, and an absolute change in the apparent direction of the object. Since no such change in the apparent direction is consequent upon the movement of the eye in its socket, it follows that the optical centre  $c'$  of the eye must coincide with its geometrical centre  $c$ .

70. The continuance of the effect produced by the image of a visible object on the retina after such object has been removed from before the eye, combined with the effect of the image of another object placed before the eye during such continuance of the effect of that which was removed, produces a class of phenomena called *ocular spectra* and *accidental colours*.

The effect produced by a strongly illuminated image formed on the retina does not appear to be merely the continuance of the same perception after the image is removed, but also a certain diminution or deadening of the sensibility of the membrane to other impressions. If the organ were merely affected by the continuance of the perception of the object for a certain time after its removal, the effect of the immediate perception of another object on the retina would be the perception of the mixture of two colours. Thus, if the eye, after contemplating a bright yellow object, were suddenly directed to a similar object of a light red colour, the effect ought to be the perception of an orange colour; and this perception would continue until the effect of the yellow object on the retina would cease, after which the red object would alone be perceived.

Thus, for example, a disk of white paper being placed upon a black ground, and over it a red wafer which will exactly cover it being laid, if, closing one eye, and gazing intently with the other for a few seconds on the red wafer, the red wafer be suddenly removed so as to expose the white surface under it to the eye, the effect ought to be the combination of the perception of red which continues after the removal of the red wafer, with the perception of white which the uncovered surface produces; and we should consequently expect to see a diluted red disk,



## THE EYE.

similar to that which would be produced by the mixture of red with white.

This, however, is not the case. If the experiment be performed as here described, the eye will, on the removal of the red wafer, perceive, not a reddish, but a greenish-blue disk.

In like manner, if the wafer, instead of being red, were of a bright greenish-blue, when removed the impression on the eye would be that of a reddish disk.

These and like phenomena are explained as follows:—

When the eye is directed with an intensity of gaze for some time at the red surface, that part of the retina upon which the image of the red wafer is produced becomes fatigued with the action of the red light, and loses to some extent its sensibility to that light, exactly as the ear is deafened for a moment by an overpowering sound. When the red wafer is removed, the white disk beneath it transmits to the eye the white light, which is composed of all the colours of the spectrum. But the eye, from the previous action of the red light, is comparatively insensible to those tints which form the red end of the spectrum, such as red and orange, but comparatively sensible to the blues and greens, which occupy the other end. It is therefore that the eye perceives the white disk as if it were a greenish-blue, and continues to perceive it until the retina recovers its sensibility for red light.

71. A difficulty has been presented in the explanation of the functions of the eye to which, as it appears to me, undue weight has been given. It has been already explained, that the images of external objects which are depicted on the retina are inverted; and it has accordingly been asked why visible objects do not appear upside down. The answer to this appears to be extremely simple. Inversion is a relative term, which it is impossible to explain or even to conceive without reference to something which is not inverted. If we say that any object is inverted, the phrase ceases to have meaning unless some other object or objects are implied which are erect. If all objects whatever hold the same relative position, none can be properly said to be inverted; as the world turns upon its axis once in twenty-four hours, it is certain that the position which all objects hold at any moment is inverted with respect to that which they held twelve hours before, and to that which they will hold twelve hours later; but the objects as they are contemplated are always erect. In fine, since all the images produced upon the retina hold with relation to each other the same position, none are inverted with respect to others; and as such images alone can be the objects of vision, no one object of vision can be inverted with respect to any other object of vision;

## SEAT OF VISION.

and consequently, all being seen in the same position, that position is called the erect position.

72. Physiologists are not agreed as to the manner in which the perception of a visible object is obtained from the image formed in the interior of the eye. It is certain, however, that this image is the cause of vision, or that the means whereby it is produced are also instrumental in producing the perception of sight. It may also be considered as established that the perception of a visible object is more or less distinct, according to the greater or less distinctness of the image. But it would be a great error to assume that this image on the retina is itself seen, for that would involve the supposition of a second eye, beyond the first, or within it, by which such image on the retina would be viewed. Now, no means of communicating between the image on the retina and the sensorium exist except the usual conduits of all sensation, the nerves.

It has been already explained that the optic nerve, after entering the eye at a point near the nose, spreads itself over the interior of the globe of the eye behind the vitreous humour, and that this retina or network is perfectly transparent, the coloured image being formed not properly upon it, but upon the black surface of the choroid coat behind it. Now, it has been maintained, that the functions of vision are performed by this nervous membrane in a manner analogous to that by which the sense of touch is affected by external objects. The membrane of the retina, it is supposed, touching the coloured image, and being in the highest degree sensitive to it, just as the hand is sensitive to an object which it touches, receives from the coloured image an action which, being continued to the brain, produces perception there in accordance with the form and colour of the image upon the choroid. According to this view of the functions of vision, the retina *feels*, as it were, the image on the choroid, and transmits to the sensorium the impression of its colour and figure in the same manner as the hand of a blind person would transmit to the sensorium the form of an object which it touches.

73. If this hypothesis be admitted, it would follow that the retina itself would be incapable of exciting the sense of sight by the mere action of light and colours upon it. This is verified by the fact that when the image produced within the eye is formed upon a point of the optic nerve which has not the choroid behind it, no perception is produced.

In order to prove this, let three wafers be applied in a horizontal line upon a vertical screen, each separated from the other by a distance of two feet. Let the screen be placed before the observer at a distance of about 15 feet, the wafers being on a level with the eye; and let the centre wafer be so placed that a line

## THE EYE.

drawn from the right eye to it shall be perpendicular to the screen. Let the left eye be now closed, and let the right eye be directed to the extreme wafer on the left, but so that all three wafers may still be perceived. Let another person now slowly move the screen, so as to bring it nearer to the observer, maintaining, however, the middle wafer in the direction of the eye at *c*. It will be found that the screen being so moved to a distance of 10 feet from the eye, the middle wafer will appear to be suddenly extinguished, and the extreme wafers on the right and left will be seen.

74. This remarkable phenomenon is explained by showing that in this particular position of the eye and the screen the image of the middle wafer falls upon the base of the optic nerve when the choroid coat is not under it.

This will be rendered more intelligible by reference to fig. 11, where *B* is the middle wafer, *A* the left-hand, and *c* the right-

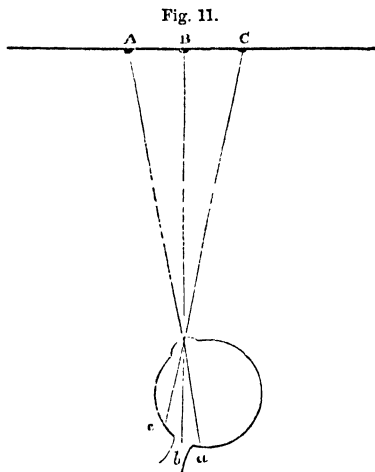

hand wafer. The image of *A* is formed at *a*, to the right of the optic nerve; and the image of *c* is formed at *c*, to the left of that nerve. In both these positions the choroid coat is behind the retina. But the image of *B* is formed at *b*, directly upon the point where the optic nerve issues from the eye-ball, and where the choroid does not extend behind it.

75. Sir David Brewster gives the following experiment as a further argument in support of this hypothesis. In the eye of the *Sepia loligo*, or cuttle-fish, an opaque membranous pigment is interposed between the retina and the vitreous humour, so that if the retina were essential to vision, the impression of the image on this black membrane must be conveyed to it by the vibration of this membrane in front of it. Sir David Brewster also mentions that in young persons the choroid coat, instead of being covered with a black pigment, reflects a brilliant crimson, like that of dogs and some other animals; and imagines that if the retina were affected by the rays which pass through it, this crimson light ought to excite a corresponding sensation, which is not the case.



## THE EYE.

### CHAPTER III.

76. Why objects are not seen double.—77. Exceptional cases.—78. The eye has no direct perception of distance or magnitude.—79. How distances are estimated.—80. Appearance of the sun and moon when rising or setting.—81. How magnitudes are estimated.—82. Illusion produced in St. Peter's at Rome.—83. Magnitude inferred from distance.—84. Perception of angular motion.—85. How real direction of motion may be inferred.—86. Examples of the sun and moon.—87-90. Effect of the motion of the observer—Examples.—91. Angular distance defined.—92. The eye has no direct perception of form—How inferred.—93. Visible area defined.—94. Figure inferred from lights and shadows.—95. Power of distinguishing colours.—96, 97. Absence of this power in particular cases.

76. THE question why, having two eyes on which independent impressions are made by external objects, and on the retina of each of which an independent picture of a visible object is formed, we do not see distinct objects corresponding to each individual external object which impresses the organ, is often asked.

The first reflection which arises on the proposition of this

## THE EYE.

question, is why the same question has not been similarly proposed with reference to the sense of hearing. Why has it not been asked why we do not hear double? why each individual sound produced by a bell or a string is not heard as two distinct sounds, since it must impress independently and separately the two organs of hearing?

It cannot be denied, that, whatever reason there be for demanding a solution of the question, why we do not see double? is equally applicable to the solution of the analogous question, why we do not hear double? Like many disputed questions, this will be stripped of much of its difficulty and obscurity by a strict attention to the meaning of the terms used in the question, and in the discussion consequent upon it. If by seeing double it be meant that the two eyes receive separate and independent impressions from each external object, then it is true that we see double. But if it be meant that the mind receives two distinct and independent impressions of the same external object, then a qualified answer only can be given.

If the two eyes convey to the mind precisely the same impression of the same external object, differing in no respect whatever, then they will produce in the mind precisely the same perception of the object; and as it is impossible to imagine two perceptions to exist in the mind of the same external object which are precisely the same in all respects, it would involve a contradiction in terms to suppose that, in such case, we perceive the object double.

If to perceive the object double mean anything,\* it means that the mind has two perceptions of the same object, distinct and different from each other in some respect. Now, if this distinctness or difference exist in the mind, a corresponding distinctness and difference must exist in the impression produced of the external object on the organs. It will presently appear, that cases do occur in which the organs are, in fact, differently impressed by the same external object; and it will also appear, that in such cases precisely we *do see double*, meaning by these terms, that we have two perceptions of the same object, as distinct from each other as are our perceptions of two different objects.

To render this point more clear, let us consider in what respects it is possible for the impressions made upon the two eyes by the same object to differ from each other.

A visible object impresses the eye with a sense of a certain apparent form, of a certain apparent magnitude, of certain colours, of a certain intensity of illumination, and of a certain visible direction. Now, if the impression produced by the same object upon the two eyes agree in all these respects, it is impossible to

## WHY WE DO NOT SEE DOUBLE.

imagine that the mind can receive two distinct perceptions of the object, for it is not possible that the two perceptions could differ from each other in any respect, except in some of those just mentioned. Let us suppose the two eyes to look at the moon, and that such object impresses them with an image of precisely the same apparent form and magnitude, of precisely the same colours and lineaments, of precisely the same intensity of illumination, and in precisely the same direction. Now, the impressions conveyed to the mind by each of the eyes corresponding in all these respects, the object must be perceived in virtue of both impressions precisely in the same manner, that is to say, it must be seen in precisely the same direction, of precisely the same magnitude, of precisely the same form, with precisely the same lineaments of light and shade, and with precisely the same brightness or intensity of illumination. It is therefore, in such a case, clearly impossible to have a double perception of the object.

It will be observed, that the same reasoning exactly will be applicable to the sense of hearing. If the same string or the same pipe affect the tympanum of each ear in precisely the same manner, so as to produce a perception of a sound of the same pitch, the same loudness, and the same quality, it is impossible to conceive that two different perceptions can be produced by the two ears, for there is no respect in which it is possible for two such perceptions to differ, inasmuch as by the very supposition they agree in all the qualities which belong to sound.

But, if we could conceive by any organic derangement that the same musical string would produce in one ear the note *ut*, and produce in the other ear the note *sol*, then the same effect would be produced as if these two sounds had been simultaneously heard by the two ears properly organised, and we should have a sense of harmony of the *fifth*.

In like manner, if the two eyes, by any defect of organisation, produced different pictures on the retina, we should then have two perceptions of the same object having a corresponding difference.

It has been already shown, that the apparent visual magnitude of an object, and also that its apparent brilliancy, depend on its distance from the eye.

Now, assuming, as we shall do, unless the contrary be expressed, that the two eyes are similarly constituted, it will follow, that an object whose distance from the two eyes is equal will be seen under the same visual angle, and will therefore have the same apparent magnitude; it will also have the same colour and intensity of illumination, and, in fine, if the distance between the

## THE EYE.

eyes bear an insignificant proportion to the distance of the object from them, the lines drawn from the centre of the eyes to any point on the object will be practically parallel; and since these lines, as has been already explained, determine the direction in which the object is seen, such object will then be seen in the same direction. Now, since the apparent form, the apparent magnitude, the apparent colour, the apparent intensity of illumination, and the apparent direction are the same for both eyes, it is clear that the same impression must be produced upon the senses, and the same perceptions conveyed to the mind; consequently it follows, demonstratively, that all objects which are placed at a distance compared with which the distance between the eyes is insignificant, will convey a single perception to the mind, and will consequently not be seen double.

77. But we have now to consider a different case, which will present peculiar conditions, and consequences of peculiar interest.

Let us suppose an object placed so near the eyes that its distance shall not bear a considerable proportion to the length of the line which separates the centres of the eyes. In this case, the images produced on the retina of the two eyes may differ in magnitude, and intensity of illumination, and even in form, and, in fine, it is clear that the apparent direction of any point on the object as seen by the two eyes will be sensibly different.

In this case, therefore, the two eyes convey to the mind a different impression of the same object; and we may therefore expect that we should see it double, and in fact we do so.

But the observation of this particular phenomenon requires much attention, inasmuch as the perception of which we are conscious is affected not merely by the impression made upon the organ of sense, but by the degree of attention which the mind gives to it. Thus, if the two eyes be differently impressed either by the same or by different objects placed before them, the mind may give its attention so exclusively to either impression, as to lose all consciousness of the other.

Thus, if two stars be at the same time in the field of view of a telescope, as frequently happens, and be viewed together by the eye, we shall be conscious of a perception of both, so long as the attention is not exclusively directed to either; but if we gaze intently on one of them so as to observe its colour, or any other peculiarity attending it, we shall cease to be conscious of the presence of the other. The application of this observation to the question before us will be presently apparent.

Let  $RL$ , fig. 12, be the line separating the centres of the two eyes,  $R$  representing the centre of the right, and  $L$  that of the left eye.

## CASES IN WHICH WE SEE DOUBLE.

Let  $o$  be an object, such as the flame of a candle or lamp, seen at the distance of about 40 feet, so that the lines of direction  $L o$  and  $R o$  converging upon it from the centres of the eyes may be regarded as practically parallel, the distance being about 200 times greater than the distance  $L R$  between the eyes. The object  $o$  will therefore be seen in the same direction by both eyes, and being at a distance from the two eyes practically equal, will have the same apparent magnitude, form, colour, and intensity of illumination, and, consequently, will be seen single.

Fig. 12.



Let a small white rod be held at the distance  $A$ , of about 8 inches from the left eye  $L$ , and in the line  $L o$ , so as to intercept the view of the object  $o$  from the left eye. The left eye will then see the rod at  $A$ , and not the object  $o$ ; but the right eye will still see the object  $o$ , as before. Now, if the attention be earnestly directed to the object  $o$ , the object  $A$  will not be perceived; but if the attention be directed to the object  $A$ , it will be perceived distinctly, but the object  $o$  will be seen through it as if it were transparent.

Now, since the object  $o$  cannot be seen by the left eye under the circumstances here supposed, the perception we have of it must be derived from the right eye; nevertheless it is seen in the line  $L A o$ , immediately beyond the intercepting wand, and in the same direction, and in the same manner precisely as it would be seen by the left eye  $L$  if the intercepting wand were removed. It follows, therefore, that the perception we obtain of the object  $o$  by the right eye is precisely the same as that which we should obtain by the left eye if the right were closed, and the intercepting wand  $A$  removed. This may therefore be taken as an experimental proof of what, indeed, may seem sufficiently evident, *à priori*, that an object, such as  $o$ , placed at a distance so great that lines drawn to it from the centre of the eyes would be practically parallel, produces precisely the same perception through the vision of both eyes.

But when the distance of an object from the eye is so small that the line which separates the eyes bears a considerable proportion to it, the directions in which such an object is seen by the two eyes are different, and it is easy to show that in this case such an object would be seen double.

Let  $L$ , and  $R$  (fig. 13), as before, be the centres of the two eyes, and let  $A B$  be a white screen placed vertically at a distance of 12 or 14 feet, having upon it a horizontal line on a level with the eye, upon which is marked a divided scale 1, 2, 3, 4, 5, 6, 7, 8, 9, 10. Let a black wand be held vertically at  $o$ , opposite the middle



## THE EYE.

of the line *L R*. This wand will be seen by the left eye in the direction of the division 8, and by the right eye in the direction of the division 4, on the screen, and two images

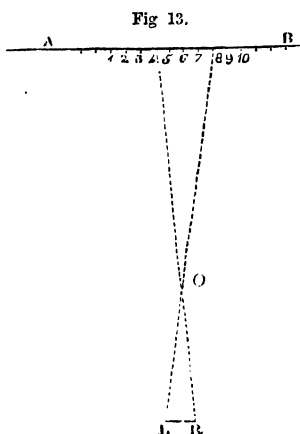

o the wand will accordingly be perceived ; but, according as the attention is directed to the one or to the other, a consciousness of them will be produced. Thus, by an act of the will we may contemplate only the objects as seen with the left eye, in which case the wand will be seen projected on the screen perpendicular to the line *AB*, at the 8th division ; and by a like act of the will, the attention being directed to the impression produced by the right eye, the wand will be seen projected on the screen at the 4th division of the scale. If the attention be withdrawn from either

of these and the wand be viewed indifferently, we shall be conscious of the two images, but not with the same distinctness as that with which we should perceive two wands placed at the 4th and 8th divisions of the scale. It will follow from this, that when we look with both eyes at any object, such as the printed page of a book, at the distance of 8 or 10 inches from the eyes, we have two images of the different parts of the page placed before the eyes, which are seen in different directions, and ought therefore to produce double vision ; but this is prevented by habitually directing our attention to one of the two, and neglecting the other.

That the perception of an object will be double if the directions in which it is seen by the two eyes are different, may also be demonstrated in the following manner :—

It has been already shown that the optical centres of the eyes cannot change their position by the mere action of the muscles which move the eye-balls in their sockets, and that the direction in which any distant object is seen by both eyes is the same, and hence it is perceived single ; but if a slight pressure be applied to the eye with the finger, the optical centre of the eye may be moved from its position, so that the direction of the same object seen by it and the other eye will not be the same. A distant object will in this case be seen double, being perceived in one direction by the eye which retains its natural position, and in another by that whose position is deranged by pressure.

## APPARENT DISTANCE.

78. It has been already explained that two similar objects whose distances from the eye are to each other in the same proportion as their linear dimensions will have the same apparent magnitude.

In like manner, if an object, such as, for example, a balloon, moves from the eye in a direct line, we have no distinct consciousness of its motion, for the line of direction in which it is seen is still the same. It is true that we may infer its motion through the air by the increase or diminution of its apparent magnitude; for, if we have reason to know that its real magnitude remains unchanged, we ascribe almost intuitively the change of its apparent magnitude to the change of its distance; and we consequently *infer* that it is in motion either towards or from us, according as we perceive its apparent magnitude to be increased or diminished. This information, however, as to the motion of a body in a direct line to or from the centre of the eye, is not a perception obtained directly from vision, but an inference of the reason deduced from certain phenomena. It may, therefore, be stated generally, that the eye affords no perception of direct distance, and consequently none of direct motion, the term direct being understood here to express a motion in a straight line to or from the optical centre of the eye.

79. The distance of a visible object is often estimated by comparing it with the apparent magnitude and apparent distance of known objects which intervene between it and the eye.

Thus, the steeple of a church whose real height is unknown cannot by mere vision be estimated either as to distance or magnitude, since the apparent height would be the same, provided its magnitude were greater or less in proportion to its supposed distance. But, if between the steeple and the eye there intervene buildings, trees, or other objects, whose average magnitudes may be estimated, a proximate estimate of the magnitude and distance of the steeple may be obtained.

For example, if the height of the most distant building between the eye and the steeple be known, the distance of that building may be estimated by its apparent magnitude, and the distance of the steeple will be inferred to be greater than this.

80. A remarkably deceptive impression, depending on this principle, is deserving of mention here. When the disc of the sun or moon at rising or setting nearly touches the horizon, it appears of enormous magnitude compared with its apparent size when high in the firmament. Now, if the visual angle which it subtends be actually measured in this case, it will be found to be of the same magnitude. How, then, it may be asked, does it happen that the apparent magnitude of the sun at setting and at

## THE EYE.

noon are by measure the same, when they are by estimation, and by the irresistible evidence of sense, so extremely different? This is explained, not by an error of the sense, for there is none, but by an erroneous application of those means of judging or estimating distance which in ordinary cases supply true and just conclusions.

When the disc of the sun is near the horizon, a number of intervening objects of known magnitude and known relative distances supply the means of spacing and measuring a part at least of the distance between the eye and the sun; but when the sun is in the meridian, no such objects intervene. The mind, therefore, assigns a greater magnitude to the distance, a part of which it has the means of measuring, than to the distance no part of which it can measure; and accordingly an impression is produced, that the sun at setting is at a much greater real distance than the sun in the meridian; and since its apparent magnitude in both cases is the same, its real magnitude must be just so much greater as its estimated distance is greater. The judgment, therefore, and not the eye, assigns this erroneous magnitude to the disc of the sun.

It is true that we are not conscious of this mental operation. But this unconsciousness is explained by the effect of habit, which causes innumerable other operations of the reason to pass unobserved.

81. As the eye forms no immediate perception of distance, neither does it of form or of magnitude, since, as has been already proved, objects of very different real magnitudes have the same apparent magnitude to the eye, of which a striking example is afforded in the case of the sun and moon. Nevertheless, although the eye supplies no immediate perception of the real magnitude of objects, habit and experience enable us to form estimates more or less exact of these magnitudes by the comparison of different effects produced by sight and touch.

Thus, for example, if two objects be seen at the same distance from the eye, the real magnitude of one of which is known, that of the other can be immediately inferred, since, in this case, the apparent magnitudes will be proportional to the real magnitudes. Thus, for example, if we see the figure of a man standing beside a tree, we form an estimate of the height of the latter, that of the former being known or assumed. Ascribing to the individual seen near the tree the average height of the human figure, and comparing the apparent height of the tree with his apparent height, we form an estimate of the height of the tree.

82. It is by this kind of inference that buildings constructed upon a scale greatly exceeding common dimensions are estimated, and rendered apparent in pictorial representations of them.

## ESTIMATE OF REAL MOTION.

On entering, for example, the aisle of St. Peter's at Rome, or St. Paul's at London, we are not immediately conscious of the vastness of the scale of these structures; but if we happen to see at a distant part of the building a human figure, we immediately become conscious of the scale of the structure, for the known dimensions of this figure supply a modulus which the mind instantly applies to measure the dimensions of the whole. For this reason artists, when they represent these structures, never fail to introduce human figures in or near them.

83. It has been explained that the apparent magnitude of objects depends conjointly on their real magnitude and their distance. Although, therefore, the eye does not afford any direct perception either of real magnitude or distance, we are by habit enabled to infer one of these from the other.

Thus, if we happen to know the real magnitude of a visible object, we form an estimate of its distance from its apparent magnitude; and, on the other hand, if we happen to know or can ascertain the distance of an object, we immediately form some estimate of its real magnitude.

Thus, for example, the height of a human figure being known, if we observe its apparent visual magnitude to be extremely small, we know that it must be at a distance proportionally great. If we know that at 20 feet the figure of a man will have a certain apparent height, and that we find that his figure seen at a certain distance appears to have only one-fifth of this height, we infer that his distance must be about 100 feet.

In like manner, the real magnitude may be inferred from the apparent magnitude, provided the distance be known or can be ascertained. Thus, for example, in entering Switzerland by its northern frontier, we see in the distance, bounding the horizon, the line of the snowy Alps, and the first impression is that of disappointment, their apparent scale being greatly less than we expected; but when we are informed that their distance is sixty or eighty miles, our estimate is instantly corrected, and we become conscious that the real height of mountains which, seen at so great a distance, is what we observe it, must be proportionately vast.

84. When an object moves in any direction which is not in a straight line drawn to or from the centre of the eye, the direction in which it is seen continually changes, and the eye in this case supplies an immediate perception of its motion; but this perception can be easily shown to be one not entirely corresponding to the actual motion of the object, but merely to the continual change of direction which this motion produces in the line drawn from the object to the eye.

## THE EYE.

Thus, for example, if the eye be at E (fig. 14), any object which moves from A to B will cause the line of direction in which it is seen to revolve through the angle A E B, just as though the body which moves were to describe a circular arc, of which E is the centre and E A the radius. But if, instead of moving from A to B, the body were to move from A' to B', the impression which its

Fig. 14.

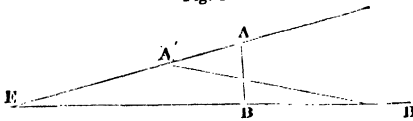

motion would produce upon the sight would be exactly the same. It would still appear to be moving from the direction E A' A to the direction E B B'.

In fine, the eye affording no perception of direct distance, supplies no evidence of the extent to which the body may change its distance from the eye during its motion, and the apparent motion will be the same as if the body in motion described a circle of which the eye is the centre.

Hence it is that the only motion of which the eye forms any immediate apprehension is angular motion, that is, a motion which is measured by the angle which a line describes, one extremity of which is at the centre of the eye, and the other at the moving object.

85. Though the real direction in which a distant object moves cannot be obtained by the direct perception of vision, some estimate of it may be formed by comparing the apparent angular motion of the object with its apparent magnitude.

Thus, for example, if we observe that the apparent magnitude of an object remains constantly the same while it has a certain apparent angular motion, we infer that its distance must necessarily remain the same, and consequently that it revolves in a circle, in the centre of which the observer is placed; or if we find that it has an angular motion, in virtue of which it changes its direction successively around us, so as to make a complete circuit of 360°, and that in making this circuit its apparent magnitude first diminishes to a certain limit, and then augments until it attains a certain major limit from which it again diminishes, we infer that such a body revolves round us at a varying distance, its distance being greatest when the apparent magnitude is least, and least when its apparent magnitude is greatest. An exact observation of the variation of the apparent magnitude would in such a case supply a corresponding estimate of the variation of the real distance, and would thus form the means of ascertaining the path in which the body moves.

86. An example of this is presented in the cases of the sun and

## APPARENT AND REAL MOTION.

moon, whose apparent magnitudes are subject, during their revolution round the earth, to a slight variation, being a minimum at one point and a maximum at the extreme opposite point, the variation being such as to show that their motions are made in an ellipse in the focus of which the earth is placed.

87. As the eye perceives the motion of an object only by the change in the direction of the line joining the object with the eye, and as this change of direction may be produced as well by the motion of the observer as by that of the object, we find accordingly that apparent motions are produced sometimes in this manner. Thus, if a person be placed in the cabin of a boat which is moved upon a river or canal with a motion of which the observer is not conscious, the banks and all objects upon them appear to him to move in a contrary direction. In this case the line drawn from the object to the eye is not moved at the end connected with the object, which it would be if the object itself were in motion, but at the end connected with the eye. The change of its direction, however, is the same as if the end connected with the object had a motion in a contrary direction, the end connected with the eye being at rest; consequently the apparent motion of the objects seen which are really at rest, is in a direction contrary to the real motion of the observer.

88. In some cases the apparent motion of an object is produced by a combination of a real motion in the object and a real motion in the observer. Thus, if a person transported in a railway carriage meet a train coming in the opposite direction, both extremes of the line joining his eye with the train which passes him are in motion in contrary directions; that extremity which is at his eye is moved by the motion of the train which carries him, and the other extremity is moved by the motion of the train which passes him. The change of direction of the line is accordingly produced by the sum of these motions; and as this change of direction is imputed by the sense to the train which passes, this train appears to move with the sum of the velocities of the two trains. Thus, if one train be moved at twenty miles an hour, while the other is moved at twenty-five miles an hour, the apparent motion of the passing train will be the same as would be the motion of a train moved at forty-five miles an hour passing a train at rest.

89. If the line joining a visible object with the eye be moved at both its extremities in the same direction, which would be the case if the observer and the object were carried in parallel lines, then the change of direction which the line of motion would undergo would arise from the difference of the velocities of the observer and of the object seen.

If the observer in this case moved slower than the object, the

## THE EYE.

extremity of the line of motion connected with the object would be carried forward faster than the extremity connected with the observer, and the object would appear to move in the direction of the observer's motion, with a velocity equal to the difference; but if, on the contrary, the velocity of the observer were greater than that of the object, the extremity of the line connected with the observer would be carried forward faster than that connected with the object, and the change of direction would be the same as if the object were moved in a contrary direction with the difference of the velocities.

It is easy to perceive that a vast variety of complicated relations which may exist between the directions and motions of the observer and of the object observed, will give rise to very complicated phenomena of apparent motion. Thus, relations may be imagined between the motion of the observer and that of the object perceived by which, though both are in motion, the object will appear stationary; the motion of the one affecting the line of direction in an equal and contrary manner to that with which it is affected by the other; and, in the same manner, either motion may prevail over the other more or less, so as to give the line of direction a motion in accordance with or contrary to the real motion of the object.

90. All these complicated phenomena of vision are presented in the problems which arise on the deduction of the real motion of the bodies composing the solar system from their apparent motions. The observer placed in the middle of this system is transported upon the earth in virtue of its annual motion round the sun with a prodigious velocity, the direction of his motion changing from day to day according to the curvature of the orbit. The bodies which he observes are also affected with various motions at various distances around the sun, the combination of which with the motion of the earth gives rise to complicated phenomena, the analysis of which is made upon the principles here explained.

91. It is usual to express the relative position in which objects are seen by the relative direction of lines drawn to them from the eye; and the angle contained by any two such lines is called the angular or visual distance between the objects. Thus, the angular distance between the objects A and B, fig. 14, is expressed by the magnitude of the angle A E B. If this angle be  $30^\circ$ , the objects are said to be  $30^\circ$  asunder. It is evident from this that all objects which lie in the direction of the same lines will be at the same angular distance asunder, however different their real distance from each other may be. Thus, the angular distance between A and B, fig. 14, is the same as the angular distance between A' and B'.

## PERCEPTION OF BULK AND FORM.

92. Sight does not afford any immediate perception either of the volume or shape of an object. The information which we derive from the sense, of the bulk or figure of distant objects, is obtained by the comparison of different impressions made upon the sense of sight by the same object at different times and in different positions. A body of the spherical form seen at a distance appears to the eye as a flat circular disk, and would never be known to have any other form, unless the impression made upon the eye were combined with other knowledge, derived from other impressions through sight or touch, or both these senses, and thus supplied the understanding with data from which the real figure of the object could be inferred. The sun appears to the eye as a flat, circular disk; but, by comparing observations made upon it at different times, it is ascertained that it revolves round one of its diameters in a certain time, presenting itself under aspects infinitely varying to the observer; and this fact, combined with its invariable appearance as a circular disk, proves it to be a sphere; for no body except a sphere, viewed in every direction, would appear circular.

Although we do not obtain from the sense of sight a perception of the shape of a body, we may obtain a perception of the shape of one of its sections. Thus, if a section of the body be made by a plane passing through it at right angles to the line of vision, the sight supplies a distinct perception of the shape of such section. Thus, if an egg were presented to the eye with its length in the direction of the line of vision, it would appear circular, because a section of it made by a plane at right angles to its length is a circle; but if it were presented to the eye with its length at right angles to the line of vision, it would appear oval, that being the shape of a section made by a plane passing through its length.

If a body, therefore, presents itself successively to the eye in several different positions, we obtain a knowledge by the sense of sight of so many different sections of it, and the combination of these sections may in many cases supply the reason with data by which the exact figure of the body may be known.

93. As the term "apparent magnitude" is used to express the visual angle under which an object is seen, we shall adopt the term *visible area* to express the apparent magnitude of the section of a visible object made by a plane at right angles to the line of vision, that is to say, to the line drawn from the eye to the centre of the object.

94. Besides receiving through the sight a perception of the figure of the section of the object which forms its visible area, we also obtain a perception of the lights and shades and the various tints of colour which mark and characterise such area. By



## THE EYE.

comparing the perception derived from the sense of touch with those lights and shades, we are enabled by experience and long habit to judge of the figure of the object from these lights and shades and tints of colour. It is true that we are not conscious of this act of the understanding in inferring shape from colour and from light and shade; but the act is nevertheless performed by the mind. The first experience of inference is the comparison of the impressions of sight with the impressions of touch; and one of the earliest acts of the mind is the inference of the one from the other. It is the character of all mental acts, that their frequent performance produces an unconsciousness of them; and hence it is that when we look at a cube or a sphere of a uniform colour, although the impression upon the sense of sight is that of a flat plane variously shaded, and having a certain outline, the mind instantly substitutes the thing signified for the sign, the cause for the effect; and the conclusion of the judgment, that the object before us is a sphere or a cube of uniform colour, and not as it appears, a flat plane variously shaded, is so instantaneous, that the act of the mind passes unobserved.

The whole art of the painter consists in an intimate practical knowledge of the relation between these two effects of perception of sight and touch. The more accurately he is able to delineate upon a flat surface those varieties of light and shade which visible objects immediately produce upon the sense, the more exact will be his delineation, and the greater the *vraisemblance* of his picture.

What is called relief in painting is nothing more than the exact representation on a flat surface of the varieties of light and shade produced by a body of determinate figure upon the eye; and it is accordingly found that the flat surface variously shaded produced by the art of the painter has upon the eye exactly the same effect as the object itself, which is in reality so different from the coloured canvas which represents it.

95. The immediate impressions received from the sense of sight are those of light and colour. The impressions of distance, magnitude, form, and motion are the mixed results of the sense of sight and the experience of touch. Even the power of distinguishing colours is not obtained immediately by vision without some cultivation of this sense. The unpractised eye of the new-born infant obtains a general perception of light; and it is certain that the power of distinguishing colours is only found after the organ has been more or less exercised by the varied impressions produced by different lights upon it. It would not be easy to obtain a summary demonstration of this proposition from the experience of infancy, but sufficient evidence to establish it is supplied by

## PECULIAR DEFECTS OF VISION.

the cases in which sight has been suddenly restored to adults blind from their birth. In these cases, the first impression produced by vision is that the objects seen are in immediate contact with the eye. It is not until the hand is stretched forth to ascertain the absence of the objects seen from the space before the eye that this optical fallacy is dissipated.

The eye which has recently gained the power of vision at first cannot distinguish one colour from another, and it is not until time has been given for experience, that either colour or outline is perceived.

96. Besides that imperfection incident to the organs of sight arising from the excess or deficiency of their refractive powers, there is another class which appear to depend upon the quality of the humours through which the light proceeding from visible objects passes before attaining the retina. It is evident that if these humours be not absolutely transparent and colourless, the image on the retina, though it may correspond in form and outline with the object, will not correspond in colour; for if the humours be not colourless, some constituents of the light proceeding from the object will be intercepted before reaching the retina, and the picture on the retina will accordingly be deprived of the colours thus intercepted. If, for example, the humours of the eye were so constituted as to intercept all the red and orange rays of white light, white paper, or any other white object, such as the sun, for example, would appear of a bluish-green colour; and if, on the other hand, the humours were so constituted as to intercept the blues and violets of white light, all white objects would appear to have a reddish hue. Such defects in the humours of the eye are fortunately rare, but not unprecedented.

97. Sir David Brewster, who has curiously examined and collected together cases of this kind, gives the following examples of these defects:—

A singular affection of the retina in reference to colour is shown in the inability of some eyes to distinguish certain colours of the spectrum. The persons who experience this defect have their eyes generally in a sound state, and are capable of performing all the most delicate functions of vision. Mr. Harris, a shoemaker at Allonby, was unable from his infancy to distinguish the cherries of a cherry-tree from its leaves, in so far as colour was concerned. Two of his brothers were equally defective in this respect, and always mistook orange for grass-green, and light green for yellow. Harris himself could only distinguish black and white. Mr. Scott, who describes his own case in the *Philosophical Transactions*, mistook pink for a pale blue, and a full red for a full green.

## THE EYE.

All kinds of yellows and blues, except sky-blue, he could discern with great nicety. His father, his maternal uncle, one of his sisters and her two sons, had all the same defect.

A tailor at Plymouth, whose case is described by Mr. Harvey, regarded the solar spectrum as consisting only of yellow and light blue; and he could distinguish with certainty only yellow, white, and green. He regarded indigo and Prussian blue as black.

Mr. R. Tucker described the colours of the spectrum as follows:—

Red mistaken for . . . . .	brown.
Orange ,, . . . . .	green.
Yellow sometimes . . . . .	orange.
Green ,, . . . . .	orange.
Blue ,, . . . . .	pink.
Indigo ,, . . . . .	purple.
Violet ,, . . . . .	purple.

A gentleman in the prime of life, whose case I had occasion to examine, saw only two colours in the spectrum, viz. yellow and blue. When the middle of the red space was absorbed by a blue glass, he saw the black space with what he called the yellow on each side of it. This defect in the perception of colour was experienced by the late Mr. Dugald Stewart, who could not perceive any difference in the colour of the scarlet fruit of the Siberian crab, and that of its leaves. Dr. Dalton was unable to distinguish blue from pink by daylight; and in the solar spectrum the red was scarcely visible, the rest of it appearing to consist of two colours. Mr. Troughton had the same defect, and was capable of fully appreciating only blue and yellow colours; and when he named colours, the names of blue and yellow corresponded to the more and less refrangible rays; all those which belong to the former exciting the sensation of blueness, and those which belong to the latter the sensation of yellowness.

In almost all these cases, the different prismatic colours had the power of exciting the sensation of light, and giving a distinct vision of objects, excepting in the case of Dr. Dalton, who was said to be scarcely able to see the red extremity of the spectrum.

Dr. Dalton endeavoured to explain this peculiarity of vision by supposing that in his own case the vitreous humour was blue, and therefore absorbed a great portion of the red and other least refrangible rays; but this opinion is, we think, not well founded. Sir J. Herschell attributes this state of vision to a defect in the sensorium, by which it is rendered incapable of appreciating exactly those differences between rays on which their colour depends.

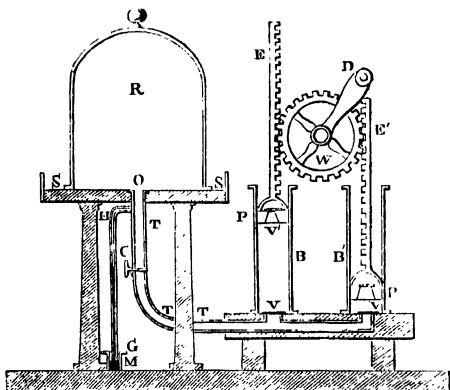

Fig. 6.—AIR-PUMP.

## THE ATMOSPHERE.

1. Experimental proofs of the weight of the atmosphere.—2. The bladder glass.—3. Pressure equal in all directions.—4. Pressure of air in a room explained.—5. Magdeburg hemispheres.—6. Suction with tube.—7. Pascal's experiment at Rouen.—8. Horror of a vacuum.—9. Galileo and the pump-makers.—10. Torricelli's celebrated experiment.—11. Pascal's experiment on the Puy-de-dôme.—12. Actual pressure of atmosphere ascertained.—13. Height of an atmosphere of uniform density.—14. Vastly greater height of an elastic atmosphere.—15. Air less and less dense in ascending.—16. Effects of atmospheric pressure.—17. Boy's plaything of a sucker.—18. Flies walking on ceiling.—19. Respiration.—20. Action of bellows.—21. Ventpeg—lid of tea-pot.—22. Pneumatic ink-bottle.—23. Syringes.—24. Exhausting syringe.—25. Rate of rarefaction.—26. Absolute vacuum cannot be obtained.—27. But may be indefinitely approached.—28. Air-pump.—29. Condensing syringe.—30. Condenser.

1. IN a former part of this series some of the most conspicuous properties of the atmosphere were explained, and among these its weight and pressure.\* We now propose to resume this subject, and to explain the expedients by which the weight, elasticity, and other mechanical properties of the atmosphere are ascertained.

\* Common Things—Air, vol. ii. p. 1.

## THE ATMOSPHERE.

2. One of the most direct demonstrations of the weight of the atmosphere is afforded by the experiment, shown in all popular lectures on physics, made with the apparatus called the Bladder Glass. This is a glass cylinder of four or five inches in diameter, open at both ends, upon one end of which a piece of bladder—rendered soft and pliable by being soaked in water, is firmly tied, the wet edges of the bladder adhering to the outside surface of the glass, and to its edge, so as to be in complete air-tight contact with it. The end of the cylinder which remains uncovered is then smeared at the edges with lard, and placed upon the plate of an air-pump, the lard rendering its contact with the plate air-tight. The air-pump, which will be described in another part of this number, is nothing more than a syringe conveniently mounted, by which the air can be partially or almost wholly, extracted from any close vessel, the mouth of which is applied upon the plate.

Let us suppose then, that by the action of the pump, a part of the air included under the bladder is withdrawn, the pressure of the air thus rarefied will be less than that of the external air, which is not so rarefied, and consequently the bladder being pressed with more force downwards than upwards, will yield to the excess of downward force, and will become concave. If by the constant action of the pump more and more of the air be withdrawn, the excess of the downward force becoming greater and greater, the bladder, if it have not sufficient strength to support the increased pressure, will burst inwards with an explosion as loud as that produced by the discharge of a large pistol.

3. The same effect will be produced in whatever direction the mouth of the bladder-glass be presented, showing that the pressure of the external atmosphere acts upon the bladder equally in all directions downwards, laterally, obliquely, and upwards.

4. Even to those who admit the great weight of a column of the atmosphere, extending from the surface of the earth to the highest limit of that fluid, this experiment performed in a room often seems astonishing and inexplicable; for however weighty may be a column of air which extends upwards to the top of the atmosphere, it cannot be understood how a column extending upwards only to the ceiling of the room can have so great a weight. It is certain that water is much heavier than air, and that a column of that liquid as high as the ceiling would not have a weight at all comparable to that which bursts the bladder.

This difficulty is explained by the common effect of fluidity, by which pressure is equally and freely transmitted in all directions through the fluid, which property was illustrated by the experiment

## BLADDER GLASS—MAGDEBURG HEMISPHERES.

with the bottle described in our Tract on Air,\* already quoted. The air included in a room is not *directly* under the pressure of a column of atmosphere extending indefinitely upwards; but it is compressed at all the openings by which it enters the room by the external air, and this pressure, which proceeds from the incumbent weight of such an atmospheric column outside the room or building, being freely transmitted inwards, the air in the room is affected by it in exactly the same manner, and to exactly the same degree, as if it were placed immediately under the incumbent weight of a column extending to the top of the atmosphere.

5. There is another familiar experiment which illustrates in a striking and instructive manner the atmospheric pressure, and which is known as that of the Magdeburg hemispheres. The apparatus known by this title is represented in fig. 1. It consists of two hollow brass hemispheres with evenly ground edges, which admit of being brought into air-tight contact when smeared with lard. The apparatus when secured upon the plate of an air-pump may be exhausted, so that the space within the hemispheres may be rendered a partial vacuum. The external air will thus press the two hemispheres together with a force proportional to the difference between the pressure of the external air and the pressure of the rarefied air within. When a sufficient exhaustion has been produced, the stop-cock attached to the lower hemisphere is closed, the apparatus is unscrewed from the pump-plate, and a handle screwed upon the lower hemisphere. It will be found that two of the strongest men will be unable to tear the hemispheres asunder, provided they are of a moderate magnitude, owing to the amount of the pressure with which they are held together. If, for example, the pressure of the rarefied air within is equivalent to a column of two inches of mercury, while the external air has a pressure represented by 30 inches of mercury, there will be a force amounting to 14 lb. per square inch on the section of the hemispheres.

If the hemisphere have 4 inches diameter, the area of their section will be  $12\frac{1}{2}$  square inches, and consequently the force with which they will be pressed together will be

$$12\frac{1}{2} \times 14 = 175 \text{ lb.}$$

This apparatus derives its name from the place where the inventor of the air-pump, Otto Guericke, first exhibited the

Fig.

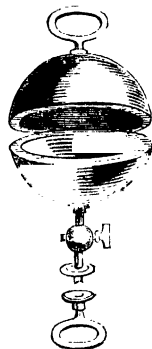

\* Vol. ii., p. 4.

## THE ATMOSPHERE.

experiment, in the year 1654. The section of the hemispheres employed by him measured 113 square inches, and they were held together by a force equal to about three-fourths of a ton.

Since the atmosphere envelopes the earth, extending everywhere above its surface to nearly the same height, it presses upon every part of the surface, upon the surfaces of extensive continents and islands, as well as upon those of oceans and seas, with the same force as that which it is shown to exert upon the bladder-glass, and the Magdeburg hemispheres.

6. Let one end of a glass tube be plunged in a vessel of water, and let the air be partially drawn from the other end by the suction of the mouth applied to it. It will be immediately observed that water will enter the tube, and will rise in it higher and higher the more air is drawn from it by the mouth. This simple experiment, so often made in the sport of children, supplies means of weighing a column of air extending from the surface of the earth to the top of the atmosphere, with as much precision as if that column could be placed in the dish of a balance, and counterpoised by equivalent weights. The water ascends in the tube, because the pressure of the air within the tube being diminished by the suction of the mouth, is less than the pressure of the air upon the surface of the water in the vessel. This latter pressure therefore predominating, forces the water up to a certain height in the tube. The weight of the column of water which thus ascends in the tube, is exactly equal to the excess of the weight of a corresponding column of air, extending from the surface to the top of the atmosphere, over the pressure of the air remaining in the tube; and it follows, that if the tube were long enough, and if, by the suction of the mouth, all the air could be withdrawn from it, a column of water would rise in the tube whose weight would be exactly equal to that of a corresponding column of the air, extending from the surface to the top of the atmosphere.

7. Now this experiment was actually made by Pascal, at Rouen, in 1646. A tube was procured, measuring 46 feet in length, but as the suction of the air from it was then considered impracticable, the difficulty was surmounted by first closing the tube at one end, and then completely filling it with water. The upper end being then well corked, so as to prevent the escape of the water, the tube was inverted by means of ropes and pulleys properly attached to it, and the corked end being immersed in a reservoir of water, and the tube being erected to the vertical position, the cork was taken out. Immediately the column of water in the tube subsided; but instead of falling altogether out of it into the reservoir, as many expected would happen, it remained suspended at a height of about 34 feet above the level of

## WATER BAROMETER.

the water in the reservoir; the other 14 feet of the tube remaining empty.

It followed, therefore, that the column of water, 34 feet high, exactly balanced a corresponding column of air extending from the surface to the top of the atmosphere.

It appears, therefore, from the result of this celebrated experiment, that every part of the surface of the globe, whether it be land or water, and of the surface of every object upon the globe, is subject to the same pressure as if it were at the bottom of a reservoir of water 34 feet deep.

8. When we look back upon the progress of physical discovery during former ages in this department of knowledge, and consider the numerous phenomena which were constantly offered by Nature herself to the least attentive and the least acute, it cannot fail to excite surprise, that the grosser and more obvious properties of that universally diffused fluid which everywhere surrounds us, and of which mankind in every age and country have so largely availed themselves for the uses of life, should remain not only undiscovered but altogether misapprehended. Even those who claimed the rank and title of philosophers seemed to have turned aside from the plain path of discovery pointed at by the finger of Nature, and with a perverseness and fatal obstinacy devoted their faculties to the invention of fanciful theories and hypotheses, having so little analogy to truth or nature, that the bare statement of them now seems grotesque.

The ancient philosophers observed, that in the instances which commonly fell under their notice space was always filled by a material substance. The moment a solid or a liquid was by any means removed, immediately the surrounding air rushed in and filled the place which it deserted: hence they adopted the physical dogma that *Nature abhors a vacuum*. Such a proposition must be regarded as a figurative or poetical expression of a supposed law of physics, declaring it to be impossible that space could exist unoccupied by matter.

Probably one of the first ways in which the atmospheric pressure presented itself was by the effect of suction with the mouth, above described. This phenomenon was accounted for by declaring that "nature abhorred a vacuum," and that she therefore compelled the water to enter the tube and fill the space deserted by the air.

The effects of suction by the mouth led by a natural analogy to suction by artificial means. If a cylinder be open at both ends, and a piston playing in it air-tight be moved to the lower end, upon immersing this lower end in water, and then drawing up the piston, an unoccupied space would remain between the piston



## THE ATMOSPHERE.

and the water. "But nature abhors such a space," said the ancients, "and therefore the water will not allow such a space to remain unoccupied: we find accordingly that as the piston rises the water follows it." By such fantastical theory pumps of various kinds were constructed.

9. The antipathy entertained by Nature against an empty space served the purposes of philosophy for a couple of thousand years, when it happened in the time of Galileo, that is, about the middle of the seventeenth century, that some engineers near Florence, being employed to sink a pump to an unusual depth, found they could raise by no exertion the water higher than 32 feet in the barrel. Galileo was consulted, and it is said, that he answered, half seriously, half sportively, that nature's abhorrence of a vacuum extended to the height of 32 feet, but that beyond this her disinclination to an empty space was not carried. The answer, however, whatever it was, does not appear to have been satisfactory, and the question continued to excite attention.

10. After the death of Galileo, Torricelli, his pupil, since become so celebrated, directed his attention to its solution. He argued, that whatever be the cause which sustains a column of water in a pump, the measure of the power thus manifested must be the weight of the column of water sustained: and, consequently, if another liquid were used, heavier bulk for bulk than water, the same force would sustain a column of that liquid, having less height in proportion as its weight would be greater. By using a heavier liquid, therefore, such as mercury, for example, the column sustained would be much shorter, and the experiment would be more manageable. The weight of mercury being bulk for bulk about  $13\frac{1}{2}$  times that of water, it followed that, if the force imputed to a vacuum could sustain 34 feet of water, it would necessarily sustain  $13\frac{1}{2}$  times less, or about 30 inches of mercury. Torricelli therefore made the following experiment, which has since become so memorable in the history of physical science.

He procured a glass tube *A B*, fig. 2, more than 30 inches long, open at one end, *A*, and closed at the other, *B*. Filling this tube with mercury, and applying his finger at the open end *A*, so as to prevent its escape, he inverted it, plunging the end *A* into mercury contained in a cistern, *c d*, fig. 2.

On removing the finger, he observed that the mercury in the tube fell, but did not fall altogether into the cistern; it only subsided until its surface *E* was at a height of about 30 inches above the surface of the mercury in the cistern.

This result, which was precisely what Torricelli had anticipated, clearly demonstrated the absurdity of the statement imputed to Galileo, that Nature's abhorrence of a vacuum extended to the

## TORRICELLI'S EXPERIMENT.

height of 32 feet, since in this case her abhorrence was limited to 30 inches. In fine, Torricelli soon perceived the true cause of this phenomenon.

The weight of the atmosphere acting upon the surface of the mercury in the cistern supports the liquid in the tube. But the surface E being excluded from contact with the atmosphere, is free from the pressure of its weight; the column, therefore, of mercury F, being pressed upwards by the weight of the atmosphere, and not being pressed downwards by any other force, would stand in equilibrium.

This explanation was further confirmed by the fact, that on admitting the air to the upper end of the tube B, by breaking off the glass at that point, or opening a stop-cock placed there, the column of mercury in the tube instantly dropped into the cistern. This was precisely the effect which ought to ensue, inasmuch as the admission of the pressure of air upon the column E balanced the pressure on the surface in the cistern, and there was no longer any force to sustain a column of mercury in the tube, and consequently it fell into the cistern.

11. This experiment and its explanation excited, at the epoch we refer to, the greatest sensation throughout the scientific world, and, like all new discoveries which have a tendency to explode long-established doctrines, was rejected by the majority of scientific men. The celebrated Pascal, who flourished at that epoch, however, had the sagacity to perceive the force of Torricelli's reasoning, and proposed to submit his experiment to a test which must put an end to all further question about it. "If," said Pascal, "it be really the weight of the atmosphere under which we live that supports the column of mercury in Torricelli's tube, we shall find, by transporting this tube upwards in the atmosphere, that in proportion as it leaves below it more and more of the air, and has consequently less and less above it, there will be a less column sustained in the tube, inasmuch as the weight of the air above the tube, which is declared by Torricelli to be the force which sustains it, will be diminished by the increased elevation of the tube."

Fig. 2.



Fig. 3.

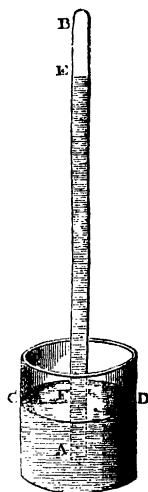

## THE ATMOSPHERE.

Pascal therefore caused Torricelli's tube to be carried to the top of a lofty mountain, called the Puy-de-dôme, in Auvergne, and the height of the column to be correctly noted during the ascent. It was found, in conformity with the principle announced by Torricelli, that the column gradually diminished in height as the elevation to which the instrument was carried increased. The experiment being repeated upon a high tower in Paris with like success, there no longer remained any doubt of the fact, that the column of mercury in the tube, as well as the column of water in common pumps is sustained, not by the force vulgarly called suction, nor by Nature's abhorrence of a vacuum, but simply by the weight of the incumbent air acting in one case on the surface of the mercury, and in the other on the surface of the water in the well, in which the pump terminates.

12. The instrument which we have here described, as used in the experiment of Torricelli, is nothing more than the common barometer.

The methods of constructing and mounting it so as to adapt it for use, and the precautions necessary to ensure the certainty and precision of its indications, will be explained in another number of this series; meanwhile it will be sufficient for the present to assume generally, that the mercurial column *E F*, suspended in the glass tube equilibrates with, and therefore measures the weight of a corresponding column of the atmosphere, extending from the surface, *C F*, of the mercury in the cistern indefinitely upwards.

It has been shown,\* that air in its usual state is  $772\frac{1}{2}$  times lighter than water. But water being  $13\frac{1}{2}$  times lighter than mercury, it follows that air must be  $13\frac{1}{2}$  times  $772\frac{1}{2}$  times lighter than mercury. By multiplying  $772\frac{1}{2}$  by  $13\frac{1}{2}$ , we obtain 10429. It follows, therefore, that 10429 cubic inches of air are equal in weight to 1 cubic inch of mercury.

13. If the atmosphere, in ascending from stratum to stratum, had constantly the same density, so that each cubic inch of air, at all heights, would have the same weight, we could at once determine its entire height by the preceding experiment; for since a column of mercury, 30 inches, or  $2\frac{1}{2}$  feet high, has the same weight as a column of air extending from the surface of the ground to the top of the atmosphere, and since the weight of the mercury, bulk for bulk, is 10429 times greater than that of air, it is evident that the height of a column of air as heavy as the column of mercury, must be 10429 times greater than that of the column of mercury, and would therefore be 10429 times  $2\frac{1}{2}$  feet, that is 26072 feet, or 5 miles very nearly.

\* Vol. ii., p. 3.

## VARYING DENSITY OF ATMOSPHERE.

Are we then to infer, that the height of the atmosphere is really not more than 5 miles? We have a thousand evidences to the contrary. The height of the summit of the mountain called Dhwalagiri, one of the Himalaya chain, has been ascertained to be 28000 feet, and clouds are seen suspended in the air far above it. The atmosphere therefore extends to a height far above 26000 feet.

14. This height of 5 miles is that which would limit the atmosphere, if air were such a fluid as water, so that stratum might be heaped upon stratum to any height, without producing any compression in the lower strata by the effect of the weight of the superior strata. Air, however, is not such a fluid. It is, as has already been shown,\* compressible without limit, and not only compressible but expansible. The air around us which composes the lowest stratum of the atmosphere, is compressed by the entire weight of the series of strata of air which are above it, and this weight, as has been already shown, amounts to 15 lb. upon a square inch of surface. Now, if any portion of this air be subjected to double that pressure, it will be contracted into half its bulk, and will consequently have twice its density; and if, on the other hand, it be relieved of half the pressure, it will expand into twice its bulk, and will consequently have only half the density. In a word, the state of air as to density will depend upon the pressure to which it is subjected. If that pressure be augmented or diminished, the density of the air will be augmented or diminished in exactly the same proportion.

15. Air being therefore elastic, and consequently indefinitely compressible and expansible, it follows that, as we ascend in the atmosphere from stratum to stratum, the density must be continually diminished, because the quantity of air above each successive stratum, being continually less, the weight pressing on the strata is continually less, and consequently the density must be proportionally less.

Hence it is apparent that the actual height of the atmosphere must be vastly greater than five miles. If the atmosphere, in ascending, were imagined to be resolved into a number of layers, each of which would contain the same weight of air, these layers would increase in thickness in ascending. Thus, if the lowest layer were 10 feet thick, a layer at such a height that half the entire atmosphere was below it, would be 20 feet thick, because being subject to only half the pressure it would have only half the density, and would therefore occupy twice the bulk. In like manner, a layer at such a height as would leave three-fourths of the atmosphere

\* Vol. ii., p. 5.

## THE ATMOSPHERE.

below it, being pressed upon by the weight of only one-fourth, would have a thickness of 40 feet, and so on.

The air, therefore, in ascending, becomes continually and indefinitely thinner and rarer. Persons who have ascended to great heights in balloons or on mountains, have accordingly found themselves in an atmosphere so rarefied as to derange seriously the vital functions.

16. The various phenomena vulgarly called suction are nothing more than so many various effects of the atmospheric pressure.

17. If a piece of moist leather be placed in close contact with any heavy body having a smooth surface, such as a stone or a piece of metal, it will adhere to it; and if a cord be attached to the leather, the stone or metal may be raised by it.

This effect arises from the exclusion of the air from between the leather and the stone. The weight of the atmosphere presses their surfaces together with a force amounting to 15 lb. on a square inch of the surface of contact.

18. The power of flies, and other insects, to walk on ceilings, smooth pieces of wood, and other similar surfaces, in doing which the gravity of their bodies appears to have no effect, is explained upon the same principle. Their feet are provided with an apparatus similar exactly to the leather applied to the stone.

19. The pressure and elasticity of the air are both called into effect in the act of respiration. When we inspire the atmosphere, we make by a muscular exertion an enlarged space within the chest. The atmospheric pressure forces the external air into this space. By another and contrary muscular exertion, the chest is then contracted, so as to squeeze out the air which has been inhaled, and which, by compression, acquires an elasticity greater than the atmospheric pressure, in virtue of which it is forced out at the mouth and nostrils.

20. The action of a common bellows is precisely similar, except that the aperture through which the air enters is different from that by which it is expelled. The analogy, however, would be complete if we inspired by the mouth and expelled by the nose. When the boards of the bellows are separated, the inner chamber is enlarged, and the air is forced in by the external pressure through the aperture governed by the leather valve or clack. The boards being then pressed together, and the escape of the air being stopped by the closed valve, it is compressed until it acquires an elasticity greater than the atmospheric pressure, and is forced out.

Bellows on a large scale are constructed with an intermediate board, so as to consist of two chambers, and to produce a continued instead of an intermittent blast. This is nothing more

## BELLOWS-PNEUMATIC INK-BOTTLE.

than a double bellows, one forcing air into the chamber of the other, and the second being urged by an uninterrupted pressure produced usually by a weight suspended from the upper board.

21. The effect produced by a vent-peg in a cask of liquid is explained by the atmospheric pressure. The cask being airtight, so long as the vent-peg is maintained in its position, the surface of the liquid in the vessel will be excluded from the atmospheric pressure, and it can only flow from the cock in virtue of its own weight. If the weight of the atmosphere be greater than the weight of a column of the liquid, corresponding with the depth of the liquid in the vessel, the liquid cannot flow from the cask; but the moment the vent-peg is removed, the atmospheric pressure being admitted above the level of the liquid in the cask, the liquid flows from the cock in virtue of its own weight.

If the lid of a teapot or kettle were perfectly close, the liquid would not flow from the pipe, because the atmospheric pressure would be excluded from the inner surface. A small hole is therefore usually made in the lid to admit the air and allow the liquid to flow freely.

22. Ink-bottles are sometimes so constructed as to prevent the inconvenience of the ink thickening and drying. Such a bottle is represented in fig. 4: A B is a close glass vessel, from the bottom of which a short tube B C proceeds, the depth of which is sufficient for the immersion of a pen. When ink is poured in at c, the bottle being placed in an inclined position, is gradually filled up to the knob A. If the bottle be now placed in the position represented in the figure, the chamber A B being filled with the liquid, the air will be excluded from it, and the pressure tending to force the ink upwards in the short tube c, will be equal to the weight of the column of ink, the height of which is equal to the depth of the ink in the bottle A B, and the bore of which is equal to the section of the tube c. The ink will be prevented from rising in the tube c by the atmospheric pressure, which is much greater than the pressure of the column of liquid in the bottle. As the ink in the short tube c is consumed by use, its surface will gradually fall to a level with the horizontal tube B, a small bubble of air will then insinuate itself through B, and will rise to the top of the bottle A B, where it will exert an elastic pressure, which will cause the surface of the ink in c to rise a little higher; and this effect will be continually repeated, until all the ink in the bottle has been used.

Fig. 4.

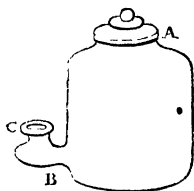

## THE ATMOSPHERE.

Birdcage fountains are constructed on the same principle.

The peculiar gurgling noise produced in decanting wine arises from the pressure of the atmosphere forcing air into the interior of the bottle to replace the liquid which escapes.

23. The common syringe by which air is withdrawn from or condensed in any vessel derives its efficacy altogether from this property of the elasticity of air.

The instrument is called an exhausting or condensing syringe, according as it is adapted to extract air from a vessel, or to force air into it.

24. To explain the principle of the exhausting syringe, let A B (fig. 5) represent a cylinder having a solid piston P, moving air-tight in it. Let C be a tube proceeding from its lower end, furnished with a stop-cock c, and let B be another tube furnished with a stop-cock D. Let the tube C be screwed upon any vessel such as R, from which it is desired to extract the air.

Fig. 5.

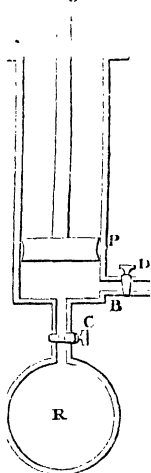

If the piston be now raised in the cylinder, the cock D being closed and the cock C being open, the air in R will necessarily expand, in virtue of its elasticity, so as to fill the enlarged space provided by raising the piston. The air which previously filled the vessel R and the connecting tube will, in fact, now fill these, and also the enlarged space in the cylinder. When the piston is brought to the top of the cylinder, let the cock C be closed and the cock D be opened. Upon driving down the piston, the air which fills the cylinder will be expelled from the tube B through the open stop-cock D. When the piston has reached the bottom of the cylinder, let D be closed and C opened,

and let the same process be repeated; the air filling the vessel R will, as before, dilate itself, so as to fill such vessel and the cylinder. The cock C being again closed, and D opened, and the piston driven down, the air which fills the cylinder will be again expelled. This process being continued, any desired quantity of air can be taken out of the vessel R and expelled into the atmosphere.

It is evident that the escape of the air from R into the cylinder is effected in virtue of its elasticity; while its escape from the stop-cock D into the atmosphere is effected in virtue of its compressibility.

25. It is easy to explain the *rate* at which the air is drawn

## EXHAUSTING SYRINGE.

from the vessel *R* by this process. If we suppose the volume of the cylinder through which the piston passes to be  $\frac{1}{10}$ th, for example, of the entire volume of the cylinder the tube and the connecting pipe taken together, then it is clear, that on completing the first downward stroke of the piston,  $\frac{1}{10}$ th of all the air included between the piston and the surface of the vessel *R* will be expelled, and  $\frac{9}{10}$ ths will consequently remain.

At every succeeding stroke,  $\frac{1}{10}$ th of what remained after the preceding stroke will be expelled, and in the same way  $\frac{9}{10}$ ths will remain.

If we suppose the vessel *R* and the connecting tube to contain ten million grains weight of air, the quantities expelled at each successive stroke, the quantities remaining, and the total quantities expelled from the commencement of the operation, will be thus exhibited in the following table:—

No. of Strokes.	Grains expelled at each stroke.	Grains remaining under pressure.	Total number of grains expelled.
1	1,000000	9,000000	1,000000
2	900000	8,100000	1,900000
3	810000	7,290000	2,710000
4	729000	6,561000	3,439000
5	656100	5,904900	4,095100
6	590490	5,314410	4,685590
7	531441	4,782969	5,217031
8	478297	4,304672	5,695328
9	430467	3,874205	6,125795
10	387421	3,486784	6,513216
11	348678	3,138106	6,861894
12	313811	2,824295	7,175705

Thus, in twelve strokes of the syringe, of the ten million of grains of air originally included, something more than seven million, or seven-tenths of the whole, have been withdrawn, and something less than three-tenths remain.

26. A rarefaction has been therefore produced in the proportion of something more than three to ten. But it will be apparent, that although by this process the rarefaction may be



## THE ATMOSPHERE.

continued to any required extent, a literal and absolute vacuum can never be produced, because some quantity of air, however small, must always remain in the vessel *R*. After every stroke of the piston, nine-tenths of the air which is in the vessel before the stroke remains in it. Now it is evident, that if we successively subtract one-tenth of any quantity, we must always have some remainder, however long the process be continued; and the same will be true, whatever proportion be thus continually subtracted.

27. Nevertheless, although an absolute vacuum cannot be obtained by such means, we can continue the process until the rarefaction shall be carried to any required extent.

In practice, the stop-cocks *D* and *C* are replaced by valves. A valve is placed at *D* which, opening outwards, is forced open by the elasticity of the air compressed under the piston when depressed, but is kept closed by the external pressure of the atmosphere when the piston is raised. The valve at *C* opens upwards, and is opened by the elasticity of the air in *R* when the piston is raised, and kept closed by the elasticity of the compressed air in the cylinder when the piston is depressed. Instead of placing a tube and valve at *B*, it is usual to make the valve in the piston itself, opening upwards; but the action is still the same. An exhausting syringe, therefore, may be shortly described to consist of a cylinder with two valves, one in the bottom, opening upwards, and one in the piston, also opening upwards. When the piston is drawn upwards, the valve in the bottom of the cylinder is opened by the pressure of the air under it, and the air passes through it. When the piston is driven downwards, the valve in the piston is opened by the elasticity of the air compressed under it, which rushes through it.

28. The air-pump is an apparatus consisting usually of two exhausting syringes, *B B'*, fig. 6, mounted so as to be worked by a single winch and handle, as represented at *D*, and communicating by a common pipe *T* with a glass vessel *R*, in which may be placed the objects of experiment. The vessel *R*, called a receiver, has an edge *S*, ground smooth, resting upon a plate, also ground smooth, and kept in air-tight connection with it by being smeared with hog's lard. A stop-cock *C* is provided in the pipe *T*, by which the communications between the receiver *R* and the syringes can be made and broken at pleasure. Another stop-cock is provided elsewhere, by which a communication can be made at pleasure between the interior of the receiver *R* and the external air. To indicate the extent to which the rarefaction is carried from time to time by the operation of the syringes, a mercurial gauge *H G M* is provided, constructed in all respects similar to a

## AIR PUMP.

barometer. The atmosphere presses on the surface of the mercury in the cistern *M*, while the column of mercury in the tube *H G* is pressed upon by the rarefied air in *R*. The height of the column, therefore, sustained in the tube, indicates the difference between the pressure of the external air and the air in the receiver.

When a gauge, of the form represented in fig. 6, is used, it is necessary that it should have the height of about 30 inches, since, when a high degree of rarefaction has been effected, a column of mercury will be sustained in the tube *H G*, very little less than in the common barometer. In small pumps, where this height would be inconvenient, a siphon-gauge, such as that represented in fig. 7, is used. This gauge is screwed on to a pipe communicating with the receiver. Mercury fills the leg *A B*, which is closed at the top *A*, and partially fills the legs *S*. When the atmosphere communicates freely with the tube *D C*, the surface of the mercury in *S* being pressed by its full force, sustains all the mercury which the tube *B A* can contain, and this tube, consequently, remains completely filled; but when the pipe *D C S* is put in communication with the exhausted receiver, the surface of the mercury in *S* being acted upon only by the pressure of the rarefied air in the receiver, the weight of the higher column in *B A* will predominate, and the mercury will fall in it, until the difference of the levels in the two legs shall be equal to the pressure of rarefied air in the receiver.

Fig. 7.

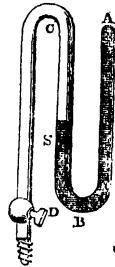

29. The condensing syringe differs from the exhausting syringe only in the direction in which the valves are placed. It consists of a cylinder and piston, as represented in fig. 5. When the piston is drawn upwards, the cock *D* is open, and *C* is closed, and the cylinder is filled with air proceeding from the external atmosphere. When the piston is pressed downwards, the cock *D* is closed and *C* is opened, and the air which filled the cylinder is forced into the vessel *R*. On raising the piston again, the cock *C* is closed and *D* is opened, and the effects take place as before. It is evident that, by every stroke of the piston, as much air as fills the cylinder is driven into the vessel *R*.

In practice, the cocks *D* and *C* are replaced by two valves, one in the bottom of the cylinder, and the other in the piston, both opening downwards, contrary to the valves in the exhausting syringe.

The operation is explained in the same manner.

30. The condenser is an apparatus which bears to the con-

## THE ATMOSPHERE.

densing syringe precisely the same relation which the air-pump bears to the exhausting syringe. It consists of one or two condensing syringes, mounted so as to be conveniently worked by a winch, and communicating with a strong reservoir, which is fastened down upon a plate, so as to be maintained in air-tight contact with it, notwithstanding the bursting pressure of air condensed within it. By the operation of syringes, volumes of air corresponding to their magnitude are forced continually into the reservoir, which becomes therefore filled with an atmosphere proportionally more dense than the external air.

Fig. 1.

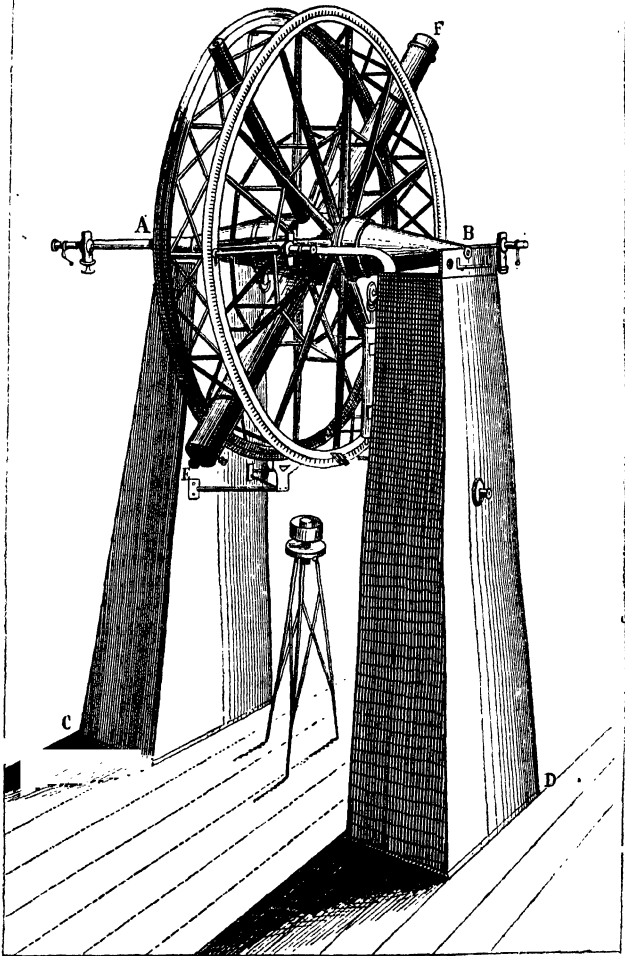

## COMMON THINGS.

TIME.

## CHAPTER I.

1. Simple notions difficult to define.—2. Conception of Time, how obtained.—3. By succession of sensible impressions.—4. Proof that such succession is necessary.—5. Time passes faster with some than with others.—6. Is measured only by a regular and uniform succession.—7. Periodic phenomena which may measure time.—8. Natural appearances intended for that purpose.—9. Significations of the word “day.”—10. Hours.—11. Their length in certain cases variable.—12. Vulgar and equinoctial hours.—13. Commencement of the day with different nations.—14. Italian time.—15. Inconvenience of such a mode of reckoning.—16. Modern method.—17. Civil and astronomical time.—18. The day the standard unit.—19. Necessary to determine it rigorously.—20. What is a day?—21. Diurnal rotation of the heavens.—22. Its constancy and uniformity.—23. Nevertheless not fitted to be the unit of civil time.—24. The meridian.—25. Diurnal motion of the sun—means of observing it.—26. Transit instrument.—27. Method of observing with it.—28. Sidereal day—its subdivisions.—29. Its permanency and uniformity—unfit, nevertheless, for a measure of time.—30. Why the sun is not fit.

### I.—TIME IN GENERAL.

1. THE most simple of our notions are those which it is most difficult to describe or define. It is fortunate that they are precisely those which least need definition. Geometers have failed in defining a straight line, or a plane surface, but no persons differ in their conceptions of the meaning of these terms. Locke observes, with his usual felicity and clearness, that a word which expresses a simple idea does not admit of definition, inasmuch as a definition being a sentence composed of two or more words having different significations, cannot collectively express one idea which has no composition at all. The only way to convey to the mind of another, the meaning of such a word, is by presenting to his senses the object or the quality which it expresses. In that case, if he possess the necessary organ of sense, he will immediately obtain the perception; if he do not all the words in the world will not convey it to him. A person blind or deaf from infancy can never acquire any perception of colours or sounds. A blind man after listening attentively to an elaborate description of the colour *scarlet*, declared that he had a very clear and satisfactory notion of it, and that he considered it like the *sound of a trumpet!*

2. Time is a word about the meaning of which it would seem that there could be no disagreement; yet we cannot as in the case of words expressing sensible ideas refer to any external object from which we can immediately receive the perception which that word expresses. Although we cannot define by words

## ORIGIN OF THE NOTION OF TIME.

the meaning of the terms white or red, we can point to the lily and the rose, and thus supersede verbal definition. We cannot define the notes of the nightingale or the lark, but if we walk forth in the night or at the early dawn, the one or the other will discourse music more eloquent than definition.

Can we then, by a like appeal to the senses, obtain a notion of what is expressed by the word TIME? Which organ does it address? Time cannot be seen, heard, felt, tasted or smelled. It cannot be seized and submitted to observation and analysis. It is the most fleeting of all perceptions. Moment follows moment in never ceasing succession, but no moment can be said to have any continued existence, so as to be submitted to contemplation.

3. Metaphysicians differ as to the mental process by which we acquire a perception of duration, but they agree generally that its origin is closely connected with the succession of our thoughts and ideas. From our observation and consciousness of this succession, and from that alone, does our original conception of time proceed. When the mind has once been stored with ideas and perceptions derived by the senses from external objects, the memory can at will reproduce them and marshal them in infinitely various series before the imagination. Of such succession of thoughts and feelings thus evoked by memory we are as distinctly conscious as we are of those derived directly from external objects, and by that consciousness we acquire a perception of time when no external objects are presented to the senses. Thus if during the darkness of night we lie awake, a constant succession of thoughts and images pass through the mind, consisting altogether of various ideas and combinations supplied by the memory. This succession of notions creates a consciousness from which we derive a perception of a certain lapse of time.

4. That an actual succession of thoughts, emotions, ideas or images, whether they proceed directly from external objects or arise from the operations of memory, reflection, or imagination, is absolutely necessary to our perception of time is demonstrated by the fact that whenever such succession ceases, our perception of time ceases with it. Thus in profound sleep without dreaming, we have no perception whatever of duration. Having gone to sleep at night, and waking, in the morning it is true that we know that a certain definite interval has elapsed, but we derive this knowledge by inference from external phenomena and not at all from consciousness. We see that the darkness of night has changed to the light of day; that the sun which was below the horizon is above it, and we know by past experience that these changes are only produced in a certain interval of time, and

## COMMON THINGS—TIME.

that such interval of time must have elapsed since we fell asleep. But if we fall asleep in the evening and do not awaken until the next day but one, we are unconscious of the lapse of more than one night. Robinson Crusoe, alone on the desert island, being indisposed, swallowed a narcotic composed of rum and the infusion of tobacco, which threw him into a profound sleep that continued from the night until the afternoon of the next day but one, and he was unconscious of the lapse of more than a single night. He found accordingly, when liberated from his solitary abode, upon comparing his journal with the actual dates, that he had lost a day in his account.

5. It might, therefore, be naturally inferred that the succession of our thoughts or mental impressions, being the origin of our perception of duration, would be necessarily a measure of duration, and indeed the only measure of it. It is easy, nevertheless, to see that such an inference can only be admitted with considerable qualification. The succession of sensible impressions produced by certain regular and uniform series of external appearances is unquestionably an exact and the only exact measure of time, but it would be, on the other hand, a grave error to assume that such a just measure of duration can result indifferently from every series of mental impressions. Who does not know that a series of agreeable thoughts and brilliant ideas has the effect of making time pass with unwonted rapidity?

“Too late I stayed. Forgive the crime !  
Unheeded flew the hours.  
How noiseless falls the foot of Time  
Which only treads on flowers !

“Ah ! who with clear account remarks  
The ebbing of his glass,  
When all its sands are diamond sparks,  
Which dazzle as they pass ?”

Again,—the series of our thoughts becomes a most fallacious measure of time when we are the sport of the more exciting passions and emotions, such as hope, fear, or despair.

“*Rosalind*. Time travels in divers paces with divers persons ; I'll tell you who time ambles withal, who time trots withal, who time gallops withal, and who he stands still withal.

“*Orlando*. I prythee, who does he trot withal ?

“*Ros*. Marry, he trots hard with a young maid, between the contract of her marriage, and the day it is solemnised. If the interim be but a se'nnight, time's pace is so hard, that it seems the length of seven years.

“*Orl*. Who ambles time withal ?

“*Ros*. With a priest that lacks Latin, and a rich man that hath not the gout : for the one sleeps easily, because he cannot study, and the other lives merrily, because he feels no pain ; the one lacking the burden of lean

## MEASURES OF TIME.

and wasteful learning, the other knowing no burden of heavy tedious penury. These time ambles withal.

“*Orl.* Who doth he gallop withal ?

“*Ros.* With a thief to the gallows : for though he go as softly as foot can fall, he thinks himself too soon there.

“*Orl.* Who stays it withal ?

“*Ros.* With lawyers in the vacation : for they sleep between term and term, and then they perceive not how time moves.”

SHAKESPEARE, *As You Like It*, Act III. Scene 2.

6. A succession of thoughts and perceptions floating at hazard through the mind, or excited casually and without regularity by external objects, produces a perception of time, but affords no measure of it ; just as the general view of a landscape produces the impression of a certain progression of distances among the objects composing it, without, however, supplying the means of estimating with numerical precision such distances.

A progression of events or perceptions which would supply a measure of time, must be absolutely uniform and regular. In such case the number of repetitions of the same event or phenomenon found between any two points of the series becomes the measure of the interval of time which has elapsed between them.

7. The series of phenomena adopted by mankind as measures of time have been either natural or artificial. Natural measures of time consist of regularly recurring periodical phenomena, which are easily and universally observable by all the world, and which never cease to be reproduced with the same uniformity in all parts of the inhabited globe. Artificial measures are usually motions which are so contrived as to be uniform so long as they continue, and which, when exhausted, admit of being restored.

Any regular periodical change, however, may serve as a measure of time. Thus woodmen ascertain the age of certain trees by marks upon their trunks. The ages of certain species of cattle are indicated by the successive formation of rings on their horns. The age of horses is ascertained by the successive disappearance of marks from their teeth.

If a candle in burning were consumed uniformly its decrease of length might be used as a measure of time. In certain sales by auction, the continuance of the bidding was limited by “inch of candle.”

8. But the periodical phenomena which have been most universally adopted in all ages and all countries as measures of time, are those which were expressly assigned for that, among many more important purposes, by the Omniscient, who, when he “made the firmament and saw that it was good,” said—

“Let there be light in the firmament of the heaven, to divide



## COMMON THINGS—TIME.

the day from the night; and let them be for signs, and for seasons, and for days, and years:

“And God made two great lights; the greater light to rule the day, and the lesser light to rule the night.”—Gen. i. 14, 16.

Days, weeks, months, and years, and the subdivisions of a day, hours, minutes, and seconds, having then been adopted by mankind in general as the measures of time, and as the landmarks of history and chronology, it may perhaps be thought that little more remains to be said about the matter; that these chronometric terms used in the common intercourse of life by all peoples—

“Familiar in their mouths as household words,”

have significations so clear, distinct, and unequivocal as to supersede the necessity of all exposition and discussion. All the world knows what a day is, and that weeks, months, and years are composed of so many of these days. We shall, nevertheless, soon render it apparent that the import of these very familiar terms is not quite so clear even in the minds of moderately well-informed persons as it is supposed to be.

### II.—THE

9. The term DAY has two distinct significations. As opposed to night, it means the interval during which we receive light from the sun. Now this interval is not very definite. According to some, it means the interval between sunrise and sunset. But according to others, it signifies the interval between the morning dawn and the termination of the evening twilight; or from the disappearance of the stars before sunrise to their reappearance after sunset.

The other sense of the word DAY is that in which it is used as a chronometric term. It is the interval of time which elapses between two successive appearances of the sun at the same point of the heavens with relation to the horizon. This interval evidently includes a day and a night.

The Greeks used a word, for which there is no English equivalent, to express this latter sense of the term DAY. This word was *νυκθημερον* (*nukthemeron*), a compound of the terms night and day.

10. From time immemorial a duodecimal division of the day has been adopted by all nations. Some peoples have counted the hours consecutively, from one to twenty-four. Others have divided the day into two series of twelve hours. It may perhaps be a legitimate subject of regret that the same system of decimal reckoning, which has conferred such simplicity upon the arithmetical

## THE HOURS.

notation and terminology, should not have been applied to the counting of time. When the spirit of innovation was in the ascendant in France in 1793, such an attempt was made, the day being divided into ten hours, the hour into an hundred minutes, and the minute into an hundred seconds. The power of custom, however, prevailed over even the domination of terrorism and the project signally failed.

11. The hours into which the day was resolved were generally intended to be equal, each being the twenty-fourth part of the entire interval called a day. Nevertheless, there were some exceptions to this. Thus, at a certain epoch in Greece, the interval between sunrise and sunset was divided into twelve equal parts called hours of the day, and the other interval, between sunset and sunrise, was also divided into twelve equal parts, called hours of the night. It is evident that the diurnal hours were equal to the nocturnal hours only at the equinoxes, and that from the spring to the autumnal equinox the diurnal were longer than the nocturnal hours, and from the autumnal to the spring equinox the nocturnal were longer than the diurnal hours. The hours, both diurnal and nocturnal, were also subject to continual variation of length. From the first day of winter, or the shortest day, to the first day of summer, or the longest day, the diurnal hours constantly increased, and the nocturnal hours constantly decreased in length; and from the first day of summer to the first day of winter, the nocturnal hours constantly increased, while the diurnal hours constantly diminished.

Such a system could not be properly denominated chronometric at all, since the interval of time called an hour was different at different seasons.

12. Defective as such a method of counting time must have been for the purposes of common life, it was utterly inadmissible for any scientific investigations; and Ptolemy, in his astronomical observations, was always obliged to transform the vulgar hours into equinoxial hours; so called, no doubt, because it was only at the equinoxes that the vulgar diurnal were equal to the nocturnal hours.

How imperfect the art of measuring time was in that age, may be imagined when it is stated that, in the observations of Ptolemy, the time of astronomical phenomena is never indicated nearer the truth than a quarter of an hour. At present it is determined in good observations to less than the tenth of a second.

13. For chronometric purposes, it is not enough to fix the value of the standard unit of time. It is necessary also to establish a convention as to the moment at which each successive unit commences, and the preceding one terminates. In a word, a point of

## COMMON THINGS—TIME.

departure must be agreed upon for each chronometric unit; and this, as will be seen, is a subject upon which much disaccord has prevailed, and the establishment of which, with all the aids afforded by the advanced state of astronomical science, has been a matter of the greatest difficulty and delicacy.

The Jews, the ancient Athenians, the Chinese, and other Oriental nations, as well as the Italians, fixed the commencement of the day at sunset. According to the Italians, even to the present times, the day is divided into twenty-four successive hours, reckoned continuously from sunset to sunset. Thus, at an hour before sunset, it is said to be twenty-three o'clock, at two hours before sunset it is twenty-two o'clock, and so on.

According to this system, the hour of sunrise varies from day to day, and from season to season, but the hour of sunset is constant, being 24 o'clock or 0 o'clock. At the equinoxes, the sun rises at twelve o'clock. From the spring to the autumnal equinoxes, it rises before twelve, and from the autumnal to the spring equinoxes, it rises after twelve.

It is evident that a clock to indicate such time must be set from day to day, or at least from week to week, since the hour of sunset would be constantly later during one half-year, and constantly earlier during the other.

14. At some places in Italy, and more particularly at Rome, public clocks are set according to this system, and others placed near them according to the common system, the indications of the one being called ITALIAN, and those of the other, FRENCH TIME.

The system of Italian time has been defended upon the ground of the convenience it affords, of always telling the hour of sunset, so as to show to travellers and those who are occupied in out-door employments the time they have at their disposition before night-fall. Against this convenience, such as it is, however, is to be considered the constant necessity from day to day of setting all the watches and clocks—an operation called by the Italians TOCCARE IL TEMPO—to touch the time. There are other obvious inconveniences, however, attending such a system, such as the constant variation of the hours of meals, of going to bed and rising; of all descriptions of regular labour, the hours of opening and closing all public offices, of commencing and terminating all public business, &c. Nevertheless, such is the force of established custom, that this mode of reckoning time still prevails to a great extent in the Italian peninsula.

The Babylonians, Syrians, Persians, the modern Greeks, and the inhabitants of the Balearic Isles, took the moment of sunrise for the commencement of the day.

15. Whether the commencement of the day be fixed at sunset

## THE HOURS.

or sunrise, the disadvantages indicated above must attend such a mode of reckoning time; to which it may be added, that of all diurnal phenomena, there is not one of which the observation is attended with more uncertainty and risk of error than sunrise and sunset.

16. The English, French, Germans, and generally the moderns in all the more civilised parts of the globe, commence the day at midnight, and divide it into two equal series of twelve hours, so that midday is twelve o'clock as well as midnight. According to this system of reckoning, it is necessary, whenever an hour is named, to indicate its relation to noon. The hours before noon are indicated by the letters A.M., and those after noon by P.M., being the initials of the Latin words *ante meridiem* (before midday), and *post meridiem* (after midday).

Among ancient astronomers who adopted this mode of reckoning, may be mentioned Hipparchus, who flourished about a hundred and fifty years before our era, and among moderns Copernicus.

The ancient Egyptians began the day at noon, in which they were followed by Ptolemy, a celebrated astronomer, who flourished at Alexandria in the second century of our era. This diurnal epoch has been by general consent adopted by modern astronomers, who divide the day into twenty-four successive hours, reckoned from noon to noon. Thus, according to their manner of reckoning, twenty minutes and an half after ten o'clock in the morning, would be 22<sup>h</sup> 20<sup>m</sup> 30<sup>s</sup>.

17. Civil or common time, therefore, is half a day before astronomical time, a circumstance which must always be carefully allowed for in the comparison of dates expressed according to the two modes of reckoning.

Thus, for example, the first day of the year 1854, according to civil reckoning, commenced at the moment of midnight, between the 31st December, 1853, and 1st January, 1854. But according to astronomical reckoning it commenced at midday on 1st January, 1854. It follows, therefore, that the twelve hours which preceded the noon of 1st January, 1854, were according to astronomical reckoning the last twelve hours of the year 1853.

In like manner, a certain hour of the forenoon, 5 A.M. of a day (Tuesday, for example), according to civil time, is 17<sup>h</sup> 0<sup>m</sup> 0<sup>s</sup> of the preceding day (Monday), according to astronomical time. From noon, however, till midnight of any given day, the civil and astronomical dates are exactly the same.

### III.—THE DAY.

18. A day then being adopted by common consent, and indeed by the force of things, as the standard unit for the measure of

time, all longer intervals being expressed by its multiples, and all shorter ones by its fractional subdivisions, it is above all things indispensable that its absolute length should be understood with perfect clearness, and ascertained with the most rigorous precision. Like all standard measures, it is necessary that it should have one invariable length, and that this length should be at all times capable of verification by comparison with some natural phenomena, observable at all times and places, and which, during an endless succession of ages, past and future, is subject to no change.

19. It may perhaps be thought that such extreme precision and permanency is needless, and that a departure of the standard from exactness by a very minute fraction would be for all practical purposes unimportant. If the standard, whatever it be, were only applied to the measurement of quantities which are not large multiples of itself, this might be admitted. But it is otherwise, when it forms a very minute fraction of that which it is applied to measure. An error of the ten-thousandth part of an inch in a foot may be unimportant, so long as short spaces—as, for example, the length of a room—only are in question. But, if we attempt to apply the foot to measure great distances, the small error is multiplied until it swells into one so great as utterly to vitiate the results. Thus an error of the ten-thousandth part of an inch in a foot becomes an error of more than an inch in two miles; of more than a foot in twenty-four miles; of more than a mile in 120000 miles, and so on.

If in the measurement of distance vast errors may thus arise from the indefinite increase of small inaccuracies of the standard units by multiplication and accumulation, it is much more so with respect to the measures of time, errors in which, even of the smallest amount, accumulating for ages, would involve not only astronomy but history and chronology in complete confusion. It will therefore be understood how important it is in many points of view, that we should obtain clear, distinct, and settled notions of the import of these terms,—days, weeks, months, and years,—which constitute our chronometric nomenclature.

20. What is a day, the fundamental unit of all time? In a rough and general way we have defined it to be the interval of time which elapses between two successive returns of the sun to the same point of the firmament. But to observe and ascertain with the necessary precision this interval, it is necessary to have some means of marking a certain point of the firmament; and, when so marked, of observing the exact moment at which the sun arrives at it. The sun, however, not being a mere point, but a circular space or *disc*, as it is called, of considerable apparent

## THE DAY.

magnitude, covers a certain part of the heavens, and different points of this disc arrive at a given point of the firmament at different moments ; so that when we speak of the moment the sun passes any given point of the heavens, our words have no definite meaning unless we specify what point of the sun's disc our observation is applied to. The point in question is of course the centre of the disc, the successive returns of which to a certain position in the heavens must be observed.

The point most convenient in all respects for such an observation is the highest to which the sun rises in its diurnal course across the heavens. But to render this position of the sun's centre, and the means of observing it intelligible, it will be necessary to consider the apparent diurnal motion of the heavens under a much more general point of view.

21. If we suppose an observer to stand with his back to the north, looking to the south, and consequently having the east upon his left, and the west upon his right, the sky being supposed to be cloudless for a day and a night, a remarkable spectacle will be presented to his view, the imposing grandeur of which continues to excite our admiration in spite of the familiarity which is produced by its never-ceasing presence.

The celestial vault presents the appearance of a vast hollow sphere, one half of which only is presented at any one moment to our view, the base of this visible hemisphere being the plane of the horizon, in the centre of which we stand. This hollow sphere appears to have a motion of rotation round a certain diameter as an axis, carrying with it as it revolves the countless objects, stars, planets, sun, and moon, which appear in various positions upon its stupendous concave surface. Standing in the position here described the sphere seems to revolve from left to right round an axis inclined to the horizon in a vertical plane, directed north and south. This apparent motion causes all the celestial objects to rise in succession on the left, that is on the east, and gradually rising they approach to and pass the vertical plane directed north and south, and after passing it, they descend upon the right, that is on the west, and in fine disappear below the horizon.

22. This diurnal motion of the celestial sphere is characterised by the most rigorous and absolute uniformity and constancy. It is never faster, never slower, and never stops. It has continued thus to move from time immemorial, and according to all appearance, and subject to the existing laws of nature, will continue so to move as long as the globe of the earth endures.

23. Such constancy and uniformity, combined with the fact that it is universally observable, would render such an apparent motion eminently fitted as a measure of time. Nevertheless as

## COMMON THINGS—TIME.

will presently appear, it is attended with other circumstances which make it unsuitable for that purpose.

24. The vertical plane directed north and south, of which we have spoken, if supposed to be extended upwards to the firmament, will meet the visible hemisphere in a semicircle which, passing through the zenith, as the point directly over the observer is called, descends to the horizon at the north and south points. This semicircle is called the MERIDIAN. It divides the visible hemisphere into two equal parts, the eastern on the left of the observer, and the western on his right. By the diurnal rotation of the celestial sphere, all objects upon it rising in the east ascend to the meridian, where they attain their greatest altitude, and then descend to the west and disappear. The interval during which each of them is visible is divided into two exactly equal parts by the meridian, the time which elapses between the moment at which it rises and that at which it passes the meridian and attains its greatest altitude, being equal to that which elapses between the latter moment, and that at which it disappears.

This movement of the heavens is more observable by night than by day, because it is then shared by a vast number of objects, having positions infinitely various upon the celestial vault. Countless numbers are every moment rising or ascending towards the meridian, passing it, or descending from it, or setting. Although the objects upon the firmament by day are not less numerous, they are rendered invisible by the superior splendour of the sun. They may nevertheless be seen even then with sufficiently powerful telescopes, and they present exactly the same apparent motion, being still carried round with the common motion imparted by the celestial sphere.

25. The sun like the rest is carried round with the diurnal motion, and its continuance above the horizon is divided into equal parts by the meridian. Hence it appears that when its centre is on the meridian, it is midday or noon, and at that moment it has its greatest altitude.

This moment then being the epoch upon which the fundamental unit of time is based, it becomes of great importance to comprehend the means which have been contrived for accurately observing it. If the meridian were traced by a visible line upon the heavens, the observation of the moment at which any celestial object crosses it would be easy. But that not being the case, it may be asked how the moment at which the sun's centre passes a merely imaginary line, can be ascertained with the extreme precision necessary in this case.

26. Astronomers have accomplished this by a very simple and

## THE TRANSIT INSTRUMENT.

admirable contrivance. They have enabled observers to mark for themselves the meridian upon the firmament with such distinctness and precision, that the moment at which any celestial object passes it can be ascertained to a small fraction of a second by direct observation.

One of the forms of instrument most easily understood by which this is accomplished is shown in fig. 1 (p. 113). The passage of any celestial object across the meridian being called a TRANSIT, instruments adapted to ascertain the moment such transits take place are called TRANSIT INSTRUMENTS. The particular form shown in fig. 1 is called a TRANSIT CIRCLE.

The instrument is mounted on two pillars, A C and B D, of solid stone, erected on a foundation of masonry presenting all the conditions necessary to guarantee the greatest firmness and solidity. These pillars stand east and west, the space between them therefore, looking north and south. A telescope E F is supported upon an horizontal axis A B, the ends of which rest in angular-shaped supports, called from their form Y's, which are established upon the summits of the two stone pillars. These supports being rendered by suitable adjustments truly horizontal, and the line joining them being directed truly east and west, the telescope when placed in an horizontal direction will point exactly north and south, and if it be turned upon its axis, so as to be successively directed to different points of the firmament, it will sweep over the celestial meridian.

Attached to the telescope is a graduated circle, consisting of two flat rims of metal, connected together in a firm manner by a system of spokes and diagonal braces. By means of this circle the altitude of any object to which the telescope may be directed can be measured; but this not being connected with our present purpose need not be further noticed. All that is now necessary to be understood is that when it is turned upon its axis, the telescope is successively directed to all points of the meridian.

When we look through the telescope, we behold a circular space upon the heavens of a certain magnitude. This space is called the FIELD OF VIEW.

The meridian is in the direction of a line which would pass vertically through the centre of this circular space, dividing it into two equal parts, one to the right, and the other to the left. The celestial objects, as they are carried by the diurnal motion of the sphere, pass from east to west across the meridian, moving in a direction apparently horizontal. Such of them, therefore, as may come within the limits of the field of view, in any one position of the telescope, will appear to pass across the field in horizontal lines; and if the observer were provided with any means



## COMMON THINGS—TIME.

of ascertaining the moment at which an object is precisely half-way between the point at which it enters and that at which it leaves the field of view, he would know the moment at which it passed the meridian.

This is accomplished by a very simple and admirable contrivance. In the eye-piece of the telescope is fixed a small frame, across which are extended vertically five or seven fine wires or filaments at equal distances apart, the centre one passing through the middle of the field of view, and one horizontal wire also passing through the centre, and therefore dividing all the vertical wires equally.

The field of view and the system of wires are shown in fig. 2, (p. 129), where *E W* is the horizontal, and *N S* the middle vertical wire. It must be observed that the wires are so extremely fine that even when they are magnified by the eye-glass of the telescope they still appear like mere hairs. The number of vertical wires being always odd, one of them will necessarily pass through the centre. The instrument represented in fig. 1 is provided with such adjustments, that the middle wire *N S*, can be brought to coincide with the utmost precision with the meridian.

The magnifying power of the telescope has the same effect upon the apparent motions of objects as upon their apparent magnitude. It increases the one in the same proportion as the other. The consequence is that, although the apparent diurnal motion of celestial objects is no more perceptible to the naked eye than is the motion of the hour-hand of a watch, yet when viewed with the telescope, this motion is very distinctly perceptible. The stars seem like so many luminous insects, creeping with a visible motion across the field in horizontal directions, and passing in succession behind each of the parallel vertical wires.

27. So rapid is this apparent motion of the celestial objects across the field of the telescope, that a star is seen to pass from one side to the other of one of the vertical wires between two successive beats of the clock. Thus it may be seen at *o*, fig. 2, at the moment marked by one beat, and at *o'*, at the moment marked by the next. Practised observers are in such case able to determine to the tenth of a second, or even less, the instant of its transit over the wire. Thus if the moment it is at *o*, be  $10^{\text{h}} 20^{\text{m}} 20^{\text{s}}$ , and that at which it is at *o'*, be  $10^{\text{h}} 20^{\text{m}} 21^{\text{s}}$ , the observer will be able to say for example that the instant at which it has passed the wire *N S* is more than  $10^{\text{h}} 20^{\text{m}} 21^{\text{s}} \cdot 4$ , and less than  $10^{\text{h}} 20^{\text{m}} 21^{\text{s}} \cdot 5$ , and he may assign the time as  $10^{\text{h}} 20^{\text{m}} 21^{\text{s}} \cdot 45$ . Different observers acquire, according to their respective aptitudes, different degrees of skill in such observations, and in all cases the results of their observations can be checked by comparing those obtained

## SIDEREAL DAY.

by two or more observers observing the same transit at the same place.

28. If the transit of the same star be observed for two or more successive nights, the interval which elapses between any two successive transits can thus be determined. Now it has been found that this interval is absolutely the same, not only for all stars whatever, but also that it is the same at whatever part of the earth the observation may be made. By comparing the results of ancient with modern observations, it has also been found that this interval has not undergone the least change.

It is well known that this apparent diurnal rotation of the heavens, by which a common motion is thus imparted to all celestial objects, is the optical effect produced by the rotation of the earth upon its axis, and the time of that rotation is consequently the interval which elapses between two successive meridional transits of any fixed star.

Such is the constant and invariable character of this motion, and its absolute uniformity, that Laplace has shown, independently of all theory, that, as a matter of fact, the time of this apparent rotation of the heavens cannot have suffered any change amounting to so much as the hundredth part of a second since the time of Hipparchus, being an interval of twenty centuries.

This interval is called a SIDEREAL DAY.

The sidereal day is subdivided into hours, minutes, and seconds, in the manner already explained.

The circumference of the celestial sphere being supposed to be divided into  $360^\circ$ , through which it revolves in 24 hours, it follows that it turns through  $15^\circ$  per hour,  $15'$  per minute, and  $15''$  per second.

It is perhaps to be regretted that the terms minutes and seconds have been used in two different senses, the more especially, as their application in both these senses is constantly necessary in all astronomical works. As applied to the arcs of circles, or to angular measurement, a MINUTE signifies the sixtieth part of a degree, and a SECOND the sixtieth part of a minute. As applied to time a MINUTE signifies the sixtieth part of an hour, and a SECOND the sixtieth part of a minute.

The confusion which might arise in calculations in which both time and angular measures are involved, is prevented by the adoption of the letters <sup>m</sup> and <sup>s</sup>, to express minutes and seconds of time, and the signs ' and '' to express angular minutes and seconds. Thus—

$$8^h 30^m 25.6^s$$

expresses an interval of time consisting of 8 hours, 30 minutes 25 seconds, and 6-tenths of a second; while

$$8^\circ 30' 25.6''$$

## COMMON THINGS—TIME.

expresses an angle or circular arc, the magnitude of which is 8 degrees, 30 minutes, 25 seconds, and 6-tenths of a second.

29. The absolute uniformity and permanency which thus characterise the diurnal rotation of the heavens, combined with the fact that it is observable at all parts of the earth, would render it eminently suitable as a measure of time. It wants, nevertheless, one condition which is quite as essential for the purposes of civil life as uniformity and permanence. It is not marked and limited by any conspicuous phenomena which strike the senses of all mankind. It does not correspond with the periodical returns of light and darkness, nor with the successive returns of the sun to the meridian. It does not even fall into accordance with the conspicuous lunar phenomena; so that, although it be true that it is observable alike in all parts of the earth, the phenomena by which it is marked are such as can only be observed with the aid of astronomical instruments, and such as do not address themselves to mankind in general.

30. To obtain, therefore, a fit measure of time for civil purposes, some measure must be found which will fall into such accordance with the periodical vicissitudes of light and darkness and the successive meridional transits of the sun, that the chronometric unit may correspond either exactly, or nearly enough, for all practical purposes with those diurnal appearances by which the records of mankind have in all ages and countries been made.

And why, it may naturally enough be asked, may not the successive returns of the sun to the meridian serve the purpose?

It may be stated briefly but distinctly that the solar diurnal phenomena, as they are actually presented in the heavens, do not answer as a measure of time even for civil, to say nothing of scientific purposes. Why they are unsuitable, and what substitute has been contrived for them, will require some words of explanation.

Fig. 2.

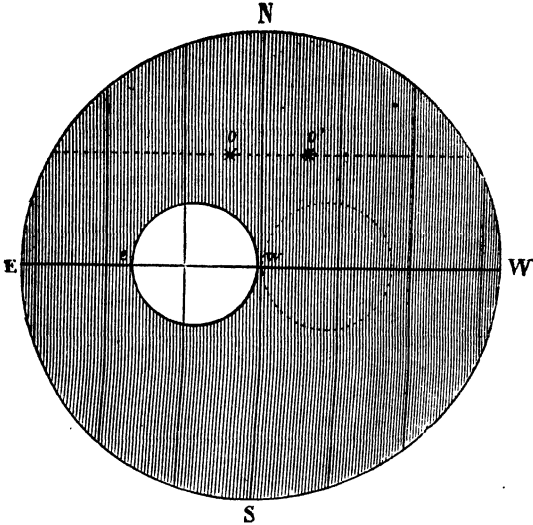

## COMMON THINGS.

### TIME.



### CHAPTER II.

31. How to observe the sun's transits.—32. Interval between them variable.—33. Mean and apparent time.—34. Relative changes of mean and apparent time.—35. The days on which they coincide.—36. The Equation of time.—37. Further explained.—38. Its extreme error.—39. Mean time adopted in France.—40. Unfitness of apparent time.—41. Local time varies with longitude.—42. Equalisation of local time proposed.—43. How time-pieces are regulated.—44. Mean solar hours, minutes, and seconds.—45. Length of sidereal day.—46. The week.—47. Opinions as to its origin.—48. Both opinions erroneous.—49. Origin of the names of the days.—50. First day of the week.—51. The month.

31. THE sun presenting to an observer not merely a brilliant point, as is the case with a fixed star, but a circular luminous space called a DISC, of considerable magnitude, the various parts of which pass the meridian at different moments of time, it is

## COMMON THINGS—TIME.

necessary to define what is meant by the meridional transit of the sun with more precision, and to show by what sort of observation the moment of such transit can be ascertained.

It has been agreed, that by the meridional transit of the sun, that of the centre of the solar disc is to be understood. But as this centre is not marked by any visible or observable point by which it can be distinguished from other points of the sun's disc, its transit cannot be directly observed.

The difficulty arising from this circumstance has been overcome by a very simple expedient.

As the solar disc enters the field of view from the east side it approaches gradually the meridional wire, *N S*, and at length touches it, as shown in fig. 2, with its western edge, *w*, or LIMB, as it is called by astronomers. The moment of this contact is observed in the manner already described in the case of a star. The solar disc then continues to move across the field until it takes the position indicated by the dotted circle, in which the eastern limb touches the meridional wire, *N S*. The moment this takes place being also observed, the middle of the interval is calculated, which is the instant at which the centre of the disc passed the meridian.\*

32. If the sun were stationary in the firmament, it is evident that the interval between its successive meridional transits would be the same as that of the successive transits of a fixed star, and in that case the SIDEREAL DAY would be identical with the SOLAR DAY. But it is well known that the sun is not thus fixed. On the contrary, it moves constantly in the firmament, making a complete circuit of the heavens in a year. If this motion were uniform, the daily displacement of the sun would be  $0^{\circ} 59' 8.2''$ .

Now let us consider what effect such a displacement, being always eastward, would produce upon the interval between the successive transits of the sun compared with that of the transits of a star which suffers no such displacement.

Let *s* (fig. 3) represent the sun at the moment its centre is on the meridian, *N S*, on any given day, and let *o* represent a fixed star which is on the meridian at the same instant. After the lapse of 24 sidereal hours the star, *o*, will be again upon the meridian, *N S*; but during these 24 hours the sun, *s*, will have moved towards *E*, that is, eastward to the position, *s'*, the distance, *s s'*, being

\* In fig. 2 the motion of the celestial objects and their position is represented as they are seen by the naked eye, or by a terrestrial telescope. But all objects are inverted and reversed by the astronomical telescope, so that the top is seen at the bottom, and the east seen at the west, and *vice versa*. It has been thought better for the present purpose to represent the points and motions as they are naturally seen.

## SUN'S TRANSITS.

$0^{\circ} 59' 8.2''$ . The sun, therefore, will not yet have come to the meridian, and will not arrive at it until it is carried by the diurnal motion of the firmament through this space of  $0^{\circ} 59' 8.2''$ . But since the firmament moves at the rate of  $15'$  in each minute of time, it will take  $3^m 56^s$  to carry the sun,  $s'$  to the meridian. It follows, therefore, that, supposing the sun to move daily  $0^{\circ} 59' 8.2''$  eastward at right angles to the meridian, a solar day would exceed a sidereal day by  $3^m 56^s$ .

If the eastward daily motion of the sun, measured at right angles to the meridian, were uniform therefore, the interval between its successive transits would possess all the requisites for a chronometric unit, and although the solar day would not be equal in length to the sidereal day, it would, nevertheless, be of invariable length, and would besides be in complete accordance with those periodical vicissitudes of light and darkness which have been, by common consent, used by mankind in all countries and in all ages as the measures of time.

But the solar day is wanting in fact in this essential condition ; it is not invariable in length. Its variation, though not great, is nevertheless such as to render it unsuitable as an unit of time, even for civil, to say nothing of astronomical, uses. No clock or watch could be constructed which would continue to go with the sun. A clock, which at one time of year would correspond with the meridional transits, would at another either anticipate them, or fall behind them.

The variation in the rate at which the sun is displaced daily towards the east, and at right angles to the meridian, arises from several causes. *First*, the rate at which the sun moves upon the firmament is subject to variation. While its average daily displacement is, as we have stated,  $0^{\circ} 59' 8.2''$ , it amounts at the beginning of the year to  $1^{\circ} 1' 9.9''$ , and at the middle of the year to only  $0^{\circ} 57' 11.5''$ . Although we are not directly concerned here with the cause of this variation, it may be as well to observe, that it arises from the fact that the earth does not revolve in an exact circle with the sun in the centre, which it must have done if its motion were uniform, but in an oval, the sun being nearer to one end than to the other, and the rate of the motion increasing as the distance of the sun decreases. *Secondly*, the motion of the sun is not generally at right angles to the meridian, but more or less oblique to it at different seasons, and the more oblique it is to the meridian, the less does a given displacement affect its eastward motion at right angles to the meridian. *Thirdly*, the

Fig. 3.

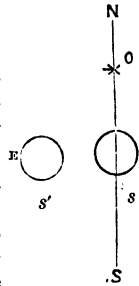

## COMMON THINGS—TIME.

sun is at different seasons at different distances from the celestial equator, and the more remote it is from the equator the more does a given displacement affect its return to the meridian, for the same reason exactly as that for which two places on the earth, at a given distance east and west of each other, will have a greater difference of longitude the farther they are from the line.

33. Seeing, then, that the interval between the successive meridional transits of the sun is subject to variation, and therefore unsuitable for a chronometric unit, but that it would be suitable if the sun's daily easterly displacement were always the same, astronomers have imagined an expedient, which, without sacrificing the advantage of an accordance with the periodical vicissitudes of light and darkness, secures the advantage of complete uniformity as to the length of the chronometric unit.

This is accomplished by the substitution for the real of a fictitious sun, whose daily easterly motion is always the same, and exactly equal to the average daily easterly motion of the real sun, that is, to  $0^{\circ} 59' 8.2''$ . The time, as indicated by this fictitious sun, is called MEAN TIME, the moment when its centre passes the meridian is called MEAN NOON, and the fictitious sun itself is sometimes called the MEAN SUN.

The variable and unavailable time indicated by the motion of the real sun is called APPARENT TIME, and the moment of the meridional transit of the real sun is called APPARENT NOON.

34. From what has been stated, it will therefore be understood that the mean and the real suns make a complete circuit of the heavens in exactly the same time, that is, in a year; so that, starting together from a given point, they will arrive together at the same point at the instant which terminates the year; but while the easterly daily displacement of the one is always absolutely the same, being  $0^{\circ} 59' 8.2''$ , that of the other is variable, being sometimes greater than  $0^{\circ} 59' 8.2''$ , sometimes less, and at certain times the same.

To illustrate the changes of the relative position of the two suns, let us imagine two railway trains to start from London at the same moment, side by side, on two lines of rails, making a trip to Liverpool and back, and to arrive at London, on their return, precisely at the same moment; but let the speed of one be absolutely uniform, at 30 miles an hour, during the entire journey, while that of the other is subject to variation, being slower in ascending inclines, and faster in descending them. The latter will at some places outstrip, and at others fall behind, the former, and at certain points they will be for a moment side by side. The variable train will represent the real, and the uniform train the fictitious or mean sun.

## MEAN AND APPARENT TIME.

The two trains throughout their trip would, in such case, never be found very far asunder. Neither will the two suns separate to any great distance. If they did so, the expedient of the fictitious sun as a measure of time for civil purposes would fail, inasmuch as the civil day would fall into perceivable disaccord with the real day.

35. The days of the year at which the true and fictitious suns come together, and on which the mean and apparent time agree, are subject to a very slight variation; but in the year 1855, this coincidence takes place on the 15th April, 15th June, 1st September, and 24th December.

To trace the relative positions of the mean and real suns, we are to consider that on the 15th April they are on the meridian together, or very nearly so. The next day the mean sun will have passed to the east of the real sun, so that the latter will arrive at the meridian first, and when the mean sun comes upon the meridian, that is, at the moment of mean noon, the real sun will be to the west of it. Each succeeding day the real sun will fall back more and more to the west of the mean sun, and the apparent noon will precede the mean noon by a constantly increasing interval. Thus, on the 16th April, the apparent precedes the mean noon by  $8^s$ , on the 17th by  $22.4^s$ , on the 18th by  $36.4^s$ , on the 19th by  $50^s$ , and so on; this gradual increase going on until the 15th May, on which day the apparent precedes the mean noon by  $3^m 53.87^s$ , and the distance of the true sun, west of the mean sun, is then  $58' 28''$ , a space equal to nearly twice the apparent diameter of the sun.

After the 15th May the real sun falls less and less west of the mean sun, so that the two suns approach each other closer and closer until the 15th June, when they again coincide. Thus, from the 15th April to the 15th June, the apparent time precedes the mean time by a quantity which varies from 0 to  $3^m 53.87^s$ , and the distance of the real sun to the west of the mean sun varies from  $0^\circ$  to  $58' 28''$ .

As the time shown by the mean sun is the time shown by a properly regulated clock, it follows that during this interval the sun passes the meridian before noon—a fact which is commonly expressed by saying that the sun is *FAST*.

36. The interval of time between the meridional transits of the real and fictitious suns, or what is the same, the interval between the apparent noon and the mean or civil noon, or the noon shown by a properly regulated clock, is called the *EQUATION OF TIME*.

37. Between the 15th April and the 15th June it appears, therefore, from what has been explained, that the time of mean noon can be deduced from that of apparent noon by subtracting



## COMMON THINGS—TIME.

from the latter the equation of time, and on the other hand, the time of apparent noon is deduced from that of mean noon by adding to the latter the equation of time.

But to trace further the relative positions of the true and mean suns. After the 15th June the real sun falls to the east of the mean sun, and consequently does not come to the meridian until after the mean sun has passed it, that is, until after noon. On the 16th June the real sun passes the meridian  $13^{\circ}53'$  later than the mean sun; on the 17th,  $26^{\circ}43'$ ; on the 18th,  $39^{\circ}42'$ ; on the 19th,  $52^{\circ}44'$ ; and so on, passing it each day later and later in the afternoon, until the 26th July, when it passes the meridian  $6^{\text{m}} 12^{\circ}68'$  later. After that day it begins to pass the meridian at earlier intervals after the mean sun, and the intervals become less and less until the 1st September, when it coincides with the mean sun.

On the 26th July the apparent noon being  $6^{\text{m}} 12^{\circ}68'$  later than mean noon, the centre of the real sun must be  $1^{\circ} 33' 10\cdot2''$  east of the centre of the mean sun, which is a space equal to about three times the apparent diameter of the sun.

Thus it appears, that from the 15th June to the 1st September, the apparent time follows the mean or civil time, that is to say, the sun passes the meridian at times varying from 0 to  $0^{\text{h}} 6^{\text{m}} 12^{\circ}68'$  in the afternoon. This fact is usually stated by saying that the sun is SLOW.

During this interval the apparent time is found by subtracting the equation of time from the mean time, and the mean time by adding it to the apparent time.

After the 1st September the real sun again passes to the west of the mean sun, and consequently passes the meridian before it.

Thus, on the 2nd September, its meridional transit takes place at  $19^{\circ}68'$  before noon; on the 3rd at  $38^{\circ}77'$ ; on the 4th at  $58^{\circ}11'$ ; and so on, the transit being earlier and earlier until the 3rd November, when it takes place at  $16^{\text{m}} 18^{\circ}51'$  before noon, which is therefore the greatest amount of the equation of time, and the greatest departure of the time of the sun from the time of the clock. The sun is in this case  $16^{\text{m}} 18^{\circ}51'$  fast.

38. Since the firmament moves at the rate of fifteen minutes of arc for every minute of time, it follows that in  $16^{\text{m}} 18^{\circ}51'$  before the meridional transit of the sun, its departure from the meridian must amount to  $4^{\circ} 4' 37\cdot65''$ , a space equal to nearly eight times the sun's apparent diameter.

From the 3rd November to the 25th December the distance of the real sun west of the mean sun constantly decreases, and they coincide on the 25th December.

It follows, therefore, that from 1st September to the 25th

## MEAN AND APPARENT TIME.

December, the sun is fast by an interval which varies from 0 to  $16^m 18.51^s$ .

After 25th December the real sun once more falls to the eastward of the mean sun, and consequently it does not arrive at the meridian until after the mean sun has passed it, that is until some time after the mean noon. On the 26th December it passes the meridian at  $40.45^s$ ; on the 27th at  $1^m 10.15^s$ ; on the 28th at  $1^m 39.71^s$  after noon, and so on, the lateness of its transit increasing until the 11th February, 1856, when it passes the meridian at  $14^m 32.36^s$  after noon. After this its transit is less and less late until the 15th April, when it again coincides with the mean sun.

It appears, therefore, that from the 25th December to the 15th April the sun is always slow, its deviation from the time of the clock being greatest on the 11th February, when it amounts to  $14^m 32.36^s$ . The distance of the true sun from the mean corresponding to this interval, computed as before, is  $3^\circ 38' 5.4''$ . On the 11th February, therefore, the true sun is at this distance east of the mean sun. This distance is not quite seven times the diameter of the sun's disc.

39. The real interval between two successive transits of the sun being variable, it is evident that no piece of mechanism could be constructed which, without adjustment, would point daily to 12 o'clock at the moment of apparent noon. So long, therefore, as the mean time was not adopted as the chronometric measure for civil purposes, it was necessary daily, or at least weekly, to regulate all the clocks, public and private, according to the varying time of apparent noon. This was the practice even in a country so enlightened as France until an epoch so recent as 1816. Before this time the most remarkable disagreement constantly prevailed among the public clocks of Paris, few of which were regulated sufficiently often by observations of the sun. M. Arago relates, that Delambre, the celebrated French astronomer, told him that he frequently heard the public clocks, one after another, striking the same hour during half an hour.

At the time of introducing the change in the regulation of the clocks of Paris from apparent to mean time, the prefect of the Seine (which is the title of the chief of the municipality, or mayor of Paris,) entertained such serious fears that an insurrectional movement might be excited among the working classes, who, it was supposed, would revolt against a noon which did not correspond with the noon of the sun, or mid-day, and which consequently would divide the day, from sunrise to sunset, into two unequal parts, that he refused to sign the *ordonnance* for the change unless it was accompanied by a formal report of the Board

## COMMON THINGS—TIME.

of Longitude to sanction it. These apprehensions, however, proved groundless, for the change took place unperceived by the great mass of the people.

Meanwhile the watch and clockmakers rejoiced at the change which established a sort of civil time, in accordance with which it was mechanically possible to construct timepieces. Such a change relieved them from the annoyance produced by the remonstrances of their customers complaining of their best constructed watches losing or gaining as much as a quarter of an hour, or even more, upon the sun. It was in vain that the celebrated Breguet, and his colleagues of the trade, assured them that the sun and not the watch was too fast or too slow.

40. It may be easily imagined how utterly incompatible with the management of public business as now conducted such an imperfect system of chronometric regulation would be, when it is considered what disastrous consequences might arise upon railways, if the starting, stopping, and arrival of trains, were not subject to greater precision than could be attained under such circumstances.

41. However exactly the chronometric measures in a given place may be regulated, their indications will necessarily differ from those of similar chronometric measures in other places having different longitudes. The cause of this difference is the successive arrival of the mean sun at the several meridians of such places. By the apparent diurnal motion of the heavens, the sun, carried round the globe, arrives in succession, from hour to hour, at the meridians of places situate one westward of the other, and as the sun thus carried round makes a complete revolution in 24 hours, it moves from meridian to meridian at the rate of  $360^\circ$  in 24 hours, or  $15^\circ$  per hour, or  $1^\circ$  in four minutes. Thus, at two places differing in their longitude by  $1^\circ$ , the local time will differ by four minutes, that which is east being four minutes earlier than that which is west.

In consequence of this the clocks in different towns of the United Kingdom show at the same moment of absolute time different hours. Liverpool, for example, being  $3^\circ$  west of London, and  $1^\circ$  being equivalent to four minutes, it follows that the sun passes the meridian of London twelve minutes before it passes that of Liverpool; and as this is equally true of the fictitious sun which regulates civil time, it follows that mean noon at London, and therefore all other hours determined with relation to mean noon, precede the corresponding hours at Liverpool by twelve minutes.

42. It has been lately proposed to assimilate the chronometric epochs at all parts of the United Kingdom, by means of clocks which are moved with a common motion, so that their hands,

## CIVIL TIME.

however distant they may be one from another, must always point at the same moment to the same hour. Such a common motion may be imparted to them by means of an electric current transmitted along conducting wires, similar to those used for the electric telegraph. In this way all clocks in all parts of the kingdom could be made to indicate the Greenwich time.

If this measure should be adopted the civil time will have undergone another change, and instead of being the mean time proper to the place, it will be the mean time at Greenwich. Thus the civil time at Liverpool, for example, would differ from the mean time there by twelve minutes. And as the mean time at certain epochs already differs from the apparent time by more than a quarter of an hour, it will sometimes happen that the civil time will differ from the apparent time by nearly half an hour. Thus the sun may be on the meridian of Liverpool, and consequently the real mid-day may take place at about half-past eleven o'clock.

Such a circumstance, however contradictory and anomalous it may appear when considered astronomically, would, however, be attended with no inconvenience in civil life.

43. The length of a mean solar or civil day, and the method of defining the moment of its commencement, being well understood, it remains to show how the motion of a timepiece is regulated so as to represent it.

Let us suppose a clock, the pendulum of which is intended to beat seconds, to be roughly regulated, so that its hour-hand shall make two complete revolutions in a day. This approximation to an exact movement may be easily accomplished by many obvious expedients, one of which would be to set it to twelve o'clock when the sun appears to have attained its greatest altitude.

The clock, thus approximately regulated, being placed near a transit instrument, such as that already described (26), let the observer, as the sun approaches the meridian, direct the telescope to the point of the meridian over which it is about to pass. When the disc of the sun enters the field of view, and is approaching the wire, *N S*, fig. 2, let the observer look at the clock, and observe the exact time, and let him count the time from that moment by his ear as he listens to the successive beats of the clock. Continuing thus to count, he will find that the western edge of the sun's disc will touch the wire *N S* at a certain moment between two successive beats, and by practice he will be able to assign the moment of contact between the beats. As the disc of the sun takes about two minutes to pass across the wire, he will have sufficient time to write down the exact time of the transit of the western edge and to return to the telescope before the eastern edge comes

## COMMON THINGS—TIME.

near the wire. Again observing the time shown by the clock, and again counting the beats he observes, in like manner, the moment at which the eastern edge touches the wire.

Now let us suppose the times of contact to be as follows:—

	H.	M.	S.
Contact of Western limb . . . .	12	10	$8\frac{2}{10}$
Contact of Eastern limb . . . .	12	11	$59\frac{2}{10}$
	<hr/>	<hr/>	<hr/>
	24	22	$7\frac{3}{10}$
Transit of sun's centre . . . .	12	11	$3\frac{3}{10}$

As has been already explained, the time of the transit of the centre of the sun's disc is found by adding together the times of the transits of the eastern and western limbs, and dividing the sum by two.

It would then appear from this that the time shown by the clock at the moment of apparent noon is eleven minutes and three seconds, and nine-tenths of a second after twelve.

Let us suppose that the observer then refers to the table of the equation of time for the day of the observation, and finds there that the moment of mean noon was  $3^m 32\frac{1}{10}^s$  earlier than the apparent noon. To find the time of mean noon, therefore, as shown by the clock, he performs the following arithmetical operation:—

	H.	M.	S.
From apparent noon . . . . .	12	11	$3\frac{9}{10}$
Subtract the equation of time . . . .		3	$32\frac{1}{10}$
	<hr/>	<hr/>	<hr/>
	12	7	$31\frac{8}{10}$

From which it appears that the clock is  $7^m 31\frac{8}{10}^s$  fast.

Leaving the clock unaltered, the same observations and calculations are made the following or any succeeding day, and if the clock gives a later hour than  $12^h 7^m 31\frac{8}{10}^s$  for mean noon, its rate is too fast, or it "gains." If it gives an earlier hour, its rate is too slow, or it "loses." Let us suppose, for example, that after the lapse of five days the clock gives  $12^h 8^m 25\frac{3}{10}^s$  for mean noon, we shall have

	H.	M.	S.
Mean noon—sixth day . . . . .	12	8	$25\frac{3}{10}$
„ first day . . . . .	12	7	$31\frac{8}{10}$
Clock gains in five days . . . . .	0	0	$53\frac{5}{10}$

The clock therefore gains at the rate of  $10\frac{7}{10}$  seconds per day.

The method of correcting the rate is by lengthening the

## MEAN NOON.

pendulum, as will be explained in a future number of the *MUSEUM*.

44. When the pendulum has been exactly regulated, it will swing 86400 times between the moments of mean noon on two successive days. The time of 60 swings will be a mean solar minute, and the time of 3600 will be a mean solar hour. The clock thus regulated, being set to 12 at the moment of mean noon, will again point to 12 at mean midnight, and again at the succeeding mean noon, and so on.

45. From what has been explained, it will be understood that a sidereal day, or the time of the rotation of the earth upon its axis, is somewhat shorter than a common civil day. The exact proportion between these chronometric units, which is by no means an easy problem, has, however, been solved by astronomers, and it is found that 100,000000 common or civil days are equal to 100,273791 sidereal days, or, if less extreme arithmetical precision be sufficient, it may be stated that in a thousand common days the earth makes  $1002\frac{3}{4}$  rotations on its axis.

From these numbers it is easy to express the time of rotation in hours, minutes, and seconds of civil time. To do this we have the proportion

100,273791 : 100,000000 :: 24 : the time of rotation.

By the rule of three, therefore, the time of rotation will be

$$\frac{2400,000000^{\text{hours}}}{100,273791} = 23^{\text{h}} 56^{\text{m}} 4.09^{\text{s}}.$$

It appears, therefore, that the time of the earth's rotation falls short of 24 hours, such as those shown by well regulated clocks, by three minutes, fifty-five seconds, and ninety-one hundredths of a second.

### IV.—THE WEEK.

46. Having thus explained fully the meaning of a day, considered as the standard unit of time, and of the subordinate and lesser divisions of hours, minutes, and seconds, it will now be necessary to notice the larger chronometric units.

The chronometric unit, in the ascending order, which comes next to the day, is the *WEEK*.\*

47. The opinions of historians and antiquarians are much divided as to the date and prevalence of the custom of counting time by periods of seven days. It is certain, however, that among the oriental nations such a period has been in use from time immemorial. Philo Judæus, Josephus, and St. Clement of

\* From the Saxon word *wroc*, having the same signification.

## COMMON THINGS—TIME.

Alexandria, maintained that the period of a week was in use among all ancient peoples. Goguet, a modern French authority, adopts the same opinion. Others, on the contrary, among whom may be mentioned Costard and Maury,\* contend that no ancient use of the period of seven days prevailed except among the Jews, who took it of course from the traditions of the creation, given in the Pentateuch.

48. Both these extreme opinions, but especially the latter, are erroneous. The week, as a division of time and multiple of a day, was in general use among the ancient Chinese, the Egyptians, the Chaldeans, and the Arabs, as well as among the Jews. It was not in the calendar of the Greeks, who divided the month into three periods of ten days, and it was not adopted by the Romans until the time of Theodosius, who reigned in the latter part of the fourth century of our era. There is properly no word in the Latin classics equivalent to the term WEEK. *Hebdomas* signified seven of anything, and when applied to days had reference to diseases, in which the physicians held (as now appears erroneously) that crises were manifested of which the periods were 7, 14, and 21 days.

While most authorities trace the use of weeks to the Mosaic account of the creation, others ascribe it to the phases of the moon, and others again to the planets as known to the ancients. The lunar phases not being even nearly commensurate with the week, they can scarcely be regarded as the origin of this chronometric unit, and the denomination of the days having in all languages more or less reference to the celestial objects, the latter opinion seems to be most generally entertained.

49. In the ancient Egyptian astronomy, the sun and moon being included among the planets, and of the bodies properly called planets, five only being known, Mercury, Venus, Mars, Jupiter, and Saturn, the total number of planets was taken to be seven. They were ranked in the order of their supposed distances from the earth as follows:—

1. SATURN	5. VENUS
2. JUPITER	6. MERCURY
3. MARS	7. THE MOON.
4. THE SUN	

Dion Cassius, an eminent historical writer of Rome, who was consul about 220 A.D., gives the following explanation of the manner in which the Egyptians derived the names of the days of the week, and their order, from those of the seven planets.

\* See dissertation by M. Biot upon the astronomical chronology.—Mem. Acad. Sc. tome xxii.

## THE WEEK.

The series of HOURS without reference to days were resolved into periods of seven, each dedicated to a planet. Thus the first hour was dedicated to SATURN, the next to JUPITER, the third to MARS, and so on. The day, however, being divided into twenty-four hours, which is not a multiple of seven, it followed necessarily that each successive day would begin with an hour dedicated to a different planet. Let us see then how the days would, according to such a system, succeed each other.

The day which begins with the hour dedicated to Saturn would evidently end with the hour dedicated to Mars, for the twenty-four hours would consist of three complete periods of seven, and the twenty-fourth hour would be the third of the fourth period and would consequently be the hour dedicated to Mars. The first hour of the next day would be that dedicated to the Sun. In like manner this day beginning with the hour dedicated to the Sun, and consisting of three hours more than three complete periods, would end with the hour dedicated to Mercury, and the next day would begin with the hour dedicated to the Moon.

The succeeding day would in like manner commence with the third in order from the Moon, that is, Mars; the next with the third in order from Mars, that is Mercury; the next with the third in order from Mercury, that is Jupiter; the next with the third in order from Jupiter, that is Venus; and after Venus the series would recommence with the hour dedicated to Saturn.

Thus in each successive period of seven days, the first hour of each successive day of the period would be dedicated to the planets in the following order:—

- |             |            |
|-------------|------------|
| 1. SATURN   | 5. MERCURY |
| 2. THE SUN  | 6. JUPITER |
| 3. THE MOON | 7. VENUS.  |
| 4. MARS     |            |

The Latin names of the days are in accordance with this,

1. DIES SATURNI (Saturn's day)
2. DIES SOLIS (Sun's day)
3. DIES LUNAR (Moon's day)
4. DIES MARTIS (Mars' day)
5. DIES MERCURII (Mercury's day)
6. DIES JOVIS (Jupiter's day)
7. DIES VENERIS (Venus' day).

These names are retained in the English language for SATURDAY, SUNDAY, MONDAY. The names for the days dedicated to Mars, Mercury, Jupiter, and Venus have been taken from Saxon divinities.



## COMMON THINGS—TIME.

The days of Mars, Jupiter, and Venus have been called **TUESDAY**, **THURSDAY**, and **FRIDAY**, from **TUESCO**, **THOR**, and **FRIGGA**, the Mars, Jupiter, and Venus of the Scandinavian mythology. The day of Mercury has been called **WEDNESDAY**, from **WODIN** or **ODIN**, the chief of the gods.

In all legislative and judiciary acts and documents, the Latin names of the days of the week are still retained.

Derivations of the Latin names, with one or two exceptions, are used in the languages of Western Europe. **SUNDAY** is an exception, the name of which is a derivative of **DIES DOMINICA**, the **LORD'S-DAY**, and **SATURDAY**, in Italian, is **SABBATO**, the **SABBATH**, that day being the Jewish Sabbath.

There is another method of connecting the series of days of the week with the seven celestial objects from which their names have been taken, so as to explain the order in which they succeed each other, which if it be only from respect to its antiquity may be worth mentioning here.

The ancient astrologers, among whom were included a large number of astronomers, properly so called, imagined a mystical figure, in the centre of which the earth was placed, surrounded by the seven celestial bodies dividing the circular space as shown in fig. 4, into seven equal arcs. From each planet's place two straight lines were supposed to be drawn to the places of the two most remote planets in the circular order, so as to form seven triangles, each of which has two rectilinear sides and an arc of the circle as its base. The planets succeed each other round this circle in the order of their then supposed distances, in the same manner as already explained. Thus Saturn is succeeded by Jupiter, which is followed by Mars, and so on as in the former case.

Now let us suppose that commencing from any one planet, the moon for example, we follow in regular succession the intersecting straight lines, we shall find that the planets succeed each other in the same order as that of the days of the week, or in the contrary order. Thus proceeding from **A**, we pass to **B**, from **B** to **C**, and so on, following the course indicated by the arrows, and the names of the planets at **A**, **B**, **C**, **D**, **E**, **F**, and **G** are precisely those from which the names of the days of the week, beginning from Monday and ending with Sunday, are taken. If we had followed the other course against the direction of the arrows, we should have obtained the names in a contrary order, as if we went backwards through the week.

In the cabalistic doctrines of astrology there were various influences imputed to the succession of planets thus obtained, with which we have however here no concern.

In both systems the number seven which forms the basis of the

## NAMES OF WEEK-DAYS.

chronometric period of a week had its origin in the supposed number of the planetary bodies. This number seven was in other respects regarded by the ancients as being invested with various mystical influences, and as being reproduced in forms infinitely various, not only in the natural objects and phenomena, but even in human events. There were the seven stars, the seven cardinal sins, the seven wonders of the world, the seven critical days in human maladies, the thrice seven years which converted a youth into a man, and so on. In short the number seven was regarded with a sort of religious veneration, so that the announcement of an eighth or ninth planet in Egypt, Greece, or Rome would, as Arago wittily observed, have been regarded as such a heresy as to bring upon the unhappy discoverer the maledictions of the priests and even the punishment of death instead of the honours and rewards of academies and universities.

50. The week being an arbitrary and conventional chronometric period, having no relation to any natural phenomenon, the day which begins it is equally so. In the Hebrew Scriptures its origin being connected with the narrative of the creation, and the institution of the Sabbath being a perpetual commemoration of the succession of divine acts by which the present state of the earth and the creatures which inhabit it were called into being, the seventh, or last day of the week, would naturally be that upon which the Sabbath is celebrated, and according to this principle Sunday would be the last and Monday the first day of the week. Such, however, has not been the conventional arrangement. The Sabbath, or seventh-day of the Jews, was the morrow of the Crucifixion, and was Saturday; the succeeding day being that of the Resurrection, was consequently the first day of the Jewish week.

Among Christians, this first day has accordingly been celebrated as Sunday, or the day of rest and prayer, the Jews still of course observing Saturday as their Sabbath.

It has therefore been generally agreed to call Sunday the first day of the week, but to invest it with those sacred attributes and characters which in the fourth commandment were conferred upon the seventh day.

## V.—THE MONTH.

51. The next chronometric unit is the month, a name which implies some correspondence with lunar phenomena. The relation of this division of time to the moon is apparent in all languages. Thus, while in Greek  $\mu\eta\nu$  (*mēn*) is *month*,  $\mu\eta\nu\eta$  (*mēnē*) is *moon*, both being derived from the Sanscrit  $M\hat{A}$ , *measure*, the Persian  $M\hat{A}H$  signifying also *month*.

## COMMON THINGS—TIME.

The sun and moon move round the celestial sphere in the same direction from west to east, but the moon moves more than thirteen times faster than the sun, and consequently makes more than thirteen revolutions of the heavens while the sun makes one. The moon is therefore constantly either departing from or approaching to and overtaking the sun. At the moment it overtakes the sun it is said to be in CONJUNCTION, and is called NEW MOON. At the moment it is in the opposite part of the heavens, and when therefore it is  $180^\circ$  removed from the sun, it is in opposition; and as it then presents its enlightened hemisphere directly towards the earth, it appears with a complete circular disc, and is called FULL MOON. When it is a quarter of the heavens, or  $90^\circ$ , before or behind the sun, it is said to be in the QUARTERS, and appears as an enlightened semicircle, and is called HALF MOON.

The time which the moon takes to make one complete revolution of the heavens, is called the moon's "period," or "periodic time," and is found by the most exact modern observations to be

27·32166 days

expressed in decimals. If expressed in hours, minutes, and seconds it is

$27^d 7^h 43^m 11\frac{4}{10}^s$ .

The moon's period is unsuitable for a measure of civil time for two reasons: first and chiefly because the moment which terminates one period and begins the next, is not marked by any conspicuous and generally observable phenomenon, and can only be ascertained by astronomers; and secondly, because it is incommensurable with the fundamental chronometric standard, the day, and as will hereafter appear, equally so with the year. For these reasons it has never been adopted as a chronometric unit either for civil or astronomical purposes.

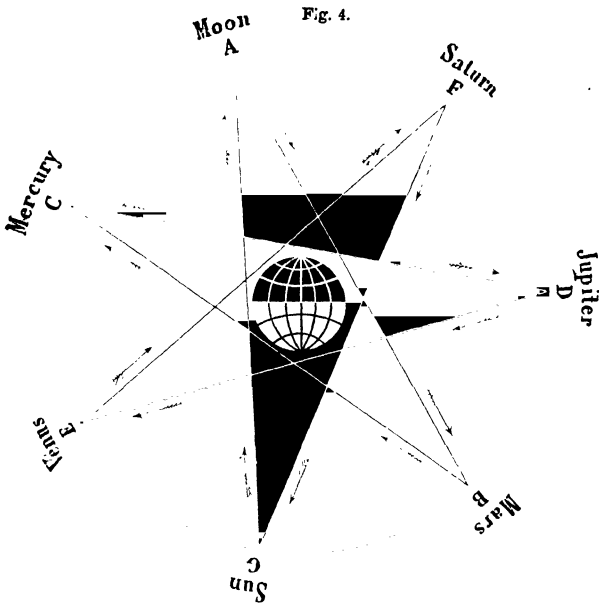

## COMMON THINGS.

### TIME.

#### CHAPTER III.

The month (continued).—52. Not conformable with lunar periods.—53. Difficulty of subdividing the year.—54. Division unequal.—55. Egyptian months.—56. Greek.—57. Solon's months.—58. Roman months.—Romulus.—59. Origin of names of months.—60. Additional months of Numa.—61. Origin of their names.—62. Their lengths.—63. Superstition in favour of odd numbers—methods of remembering the lengths of the months.—64. Calends.—65. Greek Calends.—66. Nones.—67. Ides.—68. Practice of counting backwards.—69. Discordance of the Roman year with the seasons.—70. Month Mercedonius.—71. Legal meaning of "month."—72. The year.—73. What is a year?—74. Egyptian.—75. Only a rude approximation to the course of the seasons.—76. The vague year and Sothic period.—77. Advantage of Egyptian year.—78. Greek year.—79. Meton and his cycle.—80. Origin of Golden Number.—81. Meton ridiculed by Aristophanes.—82. Near accordance of the lunar phases with the Metonic cycle.—83. Roman year.—84. Pontifical abuses.—85. Julian Calendar.—86. Bissextile years.

## COMMON THINGS—TIME.

THE interval between two successive conjunctions of the moon with the sun, or between two successive new moons, is greater than the moon's period. If we suppose the sun and moon to start together from conjunction, the moon moving more than thirteen times faster, immediately goes before the sun; and as the sun moves at the rate of about  $1^\circ$  per day, the moon must move at the rate of more than  $13^\circ$  per day, and consequently departs from the sun at the rate of more than  $12^\circ$  per day. When the moon has made a complete revolution, that is at the end of 27·32166 days from conjunction, the sun will have advanced about  $27^\circ$  from the place at which the moon arrives after having completed its revolution. The next conjunction or new moon cannot take place therefore until the moon overtakes the sun, and as it advances upon the sun at the rate of a little more than  $12^\circ$  per day, it will take somewhat more than two days to come up with it. In fine, by the most exact observations and calculations, it has been found that the interval between two successive conjunctions is

29·530589 days

expressed decimally, or in hours, minutes, and seconds

29<sup>d</sup> 12<sup>h</sup> 44<sup>m</sup> 2·89<sup>s</sup>.

This interval is called a LUNATION, and it exceeds  $29\frac{1}{2}$  days, as it appears, by a little less than three quarters of an hour.

Although the lunation is not commensurable with either the day or the year, yet its recurrence, and even its fractional parts, are marked by phenomena so striking and so universally observable without instruments, that in all ages and all countries it has by common consent been used to measure time, the fractional parts by which it exceeds 29 and falls short of 30 days, being compensated by various expedients.

The evident object to which the adoption of months was directed was to establish a convenient chronometric unit, holding an intermediate place between the week and the year; such unit to consist of a complete number of days without a fraction, and to be at the same time an exact submultiple of the year; that is, such an interval that the year should be an exact multiple of it, and finally that it should be in as near accordance as might be found practicable with the period of the lunar changes.

That various nations in different ages should be found in complete disaccord in their attempts at the satisfaction of these several conditions, and that the usages and chronological forms into which these attempts resolved themselves should exhibit much confusion, will not be at all surprising when it is considered that the conditions themselves are not only incompatible one with another, but their satisfaction utterly impracticable.

These conditions involve the consideration of three distinct

## THE MONTHS.

chronometric periods, the diurnal, the lunar, and the solar or annual. The lunar period, whatever be the phenomena on which it is based, whether it be the actual time of the revolution of the moon round the earth, or the interval between its phases, that is between full moon and full moon, is neither a multiple of the day nor a submultiple of the year. A month therefore, determined by the lunar period in whatever way it be considered, could not consist of an exact number of days, nor be so taken that the year should consist of an exact number of months.

52. All real conformity therefore between the chronometric periods derived from the sun and moon must very soon have been found to be unattainable, and the problem was therefore limited to the establishment of a convenient subdivision of the year, holding a place between the day and the year, dividing the year into an exact number of equal parts, which should be neither too great nor too small for social convenience.

53. Now let us consider how far these several conditions were attainable.

A year, as will presently appear, consists of 365 days *and a fraction*. In its chronological effects this fraction is attended with many inconveniences of its own, but we shall for the present disembarass ourselves of it and consider the year as the ancients did, to consist of the round number of 365 days.

This number is somewhat unmanageable when the object is to resolve it into equal parts, each of which shall be a whole number. It is divisible without a remainder by 5 and by 73, but by no other whole number.

It follows from this that the year admits of only two subdivisions fulfilling the prescribed conditions. It may be divided into 73 intervals of 5 days, or into 5 intervals of 73 days.

The former subdivision being less than a week, would be obviously inadmissible. By the latter the year would consist of 5 equal divisions of 73 days.

Would such a division fulfil the conditions? Would it be too great for social convenience?

The most conclusive practical answer to this question may be derived from the concurrent testimony of all nations sufficiently advanced to know that the year consists of 365 days. It must have been evident that a division into 5 equal periods of 73 days could be made. Nevertheless no such division of the year was ever proposed. By this common consent therefore such a subdivision has been tacitly but unequivocally pronounced to be unsuitable to the purposes of mankind.

54. Seeing then that no division of the year into equal periods was practicable, two expedients only were presented; *first*, to

## COMMON THINGS—TIME.

divide the year into a certain number of *equal* parts, with a remainder, and to count that remainder as a supplemental part, just as in arithmetic, when the dividend is not exactly divisible by the divisor, we give the quotient, and name the remainder; or, *secondly*, to resolve the year into some convenient number of *unequal* parts, which would be effected by distributing the days composing the remainder between the equal divisions obtained by the former expedient.

Both of these expedients have accordingly been adopted by different nations in different ages, but the latter has eventually received the general preference, and the year is now, by all the more civilised nations of the world, divided into twelve unequal parts, called, somewhat inappropriately, MONTHS.

55. The Egyptians, adopting the first of the expedients above stated, divided the year into twelve equal months of thirty days. The remaining five days formed a complementary division at the end of the year, and were intercalated before the commencement of the next year.

56. The division of the year into months by the Greeks was not only incongruous and obscure, but no two states of the confederation agreed either in the number, or the lengths, or the names of their months, nor even in the beginning of their year. Generally, however, all agreed in resolving the year into twelve months of unequal lengths. Some states commenced the year at the summer solstice, some at the winter solstice, and some at or near the autumnal equinox. A dozen or more separate states called the months by different names. Some months were designated by specific names, while others were indicated only by their numerical order, counting from the beginning of the year; but as the states did not begin their years from a common epoch, months having the same numerical designation in different states corresponded to different seasons. Thus, the fifth Attic month corresponded with November, the fifth Lacedæmonian with February, the fifth Bœotian with May, the fifth Delphic with January, and so on. The enormous confusion which must arise from such discordance between different provinces of a nation, having the same language, and the numerous and perplexing difficulties of interpretation of Greek authors, writing according to such different customs, can be easily imagined.

We forbear to encumber our pages with the eleven series of names of these months, which, being all obsolete, would have no other utility than to aid the interpretation of the Greek authors. Those who desire such information, will find sufficient for their purpose in the "Dictionary of Greek and Roman Antiquities" of Dr. Smith, Art. Calendarium.

## THE MONTHS.

57. Notwithstanding the discordancy and obscurity which surround the records and usages of the Greeks, in relation to their calendar, their knowledge of the period of the lunar phases which served as the basis of their chronometric system, attained at an early epoch of their history extraordinary precision. The lunation was estimated at  $29\frac{1}{2}$  days, which is within three quarters of an hour of its exact length, and it was assumed as their month. Solon went even so far as to make the month exactly conformable to it. The thirtieth day was divided between two successive months; the first half, from sunrise to sunset, being given to the expiring month, and the other from sunset to sunrise to the new month. The day thus shared between two different months was called *ἔνῃ καὶ νεᾷ*, the *old and new day*. This correction, however, was only applied to every other month, the intermediate months being limited to twenty-nine days.

At a later period, when this had fallen into disuse, the same name, *ἔνῃ καὶ νεᾷ*, was applied to the last day of the month generally.

58. If any evidence were sought to illustrate the difficulty which has attended the attainment of a degree of perfection in the art of counting and recording time, it would be found in a review of the state of that art among the Greeks and Romans, the two most enlightened and civilised nations of antiquity, to whose labours in literature and the sciences the moderns are so largely indebted.

Nothing that can be imagined can exceed the confusion and absurdity which prevailed in the Roman chronometric conventions before a very late period in the progress of the empire.

Romulus, the founder of Rome, established a year, consisting of ten months, six of which had thirty, and four thirty-one days, making the year 304 days.

Since the names given to these months have, for the most part, come down to modern times, and have been adopted in our own nomenclature, it will be useful here to state them, and notice their origin.

The first four months of the year of Romulus were called, MARS, APRILIS, MAÏA, and JUNIUS, from whence our names MARCH, APRIL, MAY, and JUNE.

59. The first took its name from Mars, the father of Romulus, according to the Roman fable.

The origin of the second is somewhat uncertain, some deriving it from the Latin word *aperire*, to *open*, allusive to the state of vegetation in spring; and others from *Aphrodite*, one of the Greek names of Venus.

The names of May and June were taken obviously enough



## COMMON THINGS—TIME.

from *Maia*, the mother of *Mercury*, and *Juno*, the queen of the gods.\*

The names of the other six months, expressing merely their numerical order, were—

Quintilis (the fifth)	October (the eighth)
Sextilis (the sixth)	November (the ninth)
September (the seventh)	December (the tenth).

60. A year of 304 days could not long endure, since it would be soon thrown into discordance with the nature of things. It was, accordingly, no later than the succeeding reign, that of *Numa*, that two months were added to the year. These were called *JANUARY* and *FEBRUARY*.

In the first instance, *February* stood before *January*, the former being put at the end, and the latter at the beginning of the year. This order was, however, subsequently reversed, and *January* remaining the first month of the year, *February* became the second, *March* being the third, and so on. This will explain a circumstance, which often excites inquiries in relation to the last four months of the year, which appear to hold an order in the series of months different from that indicated by their names. It must be remembered, that when they received their names *March* was the first month.

61. *JANUARY*, the first month of the year, took its name from *JANUS*, a divinity who held an important place in the Roman religion. *Janus* presided over the beginning of every thing; he was the guardian deity of gates, and was represented with two faces looking to opposite sides. He was on this account selected to preside over the first month.

*FEBRUARY* took its name from *FEBRUUS*, an ancient Italian divinity, whose rites were celebrated during the latter part of that month. This divinity also presided over the dead, whose festival, called *FERALIA*, was celebrated about the same time.

At a later period, the names of the months *QUINTILIS* and *SEXTILIS* were changed to those of *JULIUS* and *AUGUSTUS*, to commemorate these Emperors, the former of whom, as we shall see, was signalled by a most important reform of the methods of recording time. These names are continued by us for the months of *July* and *August*.

Such was the origin of the present names of the twelve months of the year.

\* Ovid gives a different derivation of the names of *May* and *June*—namely, that they are the months of the old (*majores*) and young (*juvenes*)

“*Tertius a senibus, juvenum de nomine quartus.*”

*Fasti*, Book I. line 41.

## THE MONTHS.

62. Unequal as were the lengths of the months instituted by Romulus, still greater inequality, irregularity, and confusion, were introduced by his successors. In the Romulian year of ten months, the months of March, May, Quintilis (afterwards July), and October, had each thirty-one days, all the others having thirty. When it was decided to render the year more conformable to the solar phenomena, by increasing its length, it was resolved to add fifty-one days to it; but this being considered too much for one month, and too little for two, one day was taken for each of the six months having thirty days; and the fifty-seven days thus obtained were divided into two months, twenty-nine being given to January, and twenty-eight to February.

The months then stood as follows :—

	Days.		Days.
January . . . . .	29	July (then Quintilis) . . . . .	31
February . . . . .	28	August (then Sextilis) . . . . .	29
March . . . . .	31	September . . . . .	29
April . . . . .	29	October . . . . .	31
May . . . . .	31	November . . . . .	29
June . . . . .	29	December . . . . .	29

The practice of such arithmetical caprices in dealing with matters upon which all chronological and historical records must more or less depend, would seem inexplicable if tradition had not supplied a clue to it. Why, for example, take a day from each of the months of thirty, instead of the obvious expedient of taking the *odd day* from each of those having thirty-one days?

63. It appears that in these times odd numbers were regarded as *lucky* or auspicious, even ones *unlucky* or inauspicious. A point was therefore made to create divisions of time, consisting, as far as possible, of odd numbers of days! Months of twenty-nine and thirty-one days were, therefore, preferable to months of thirty days. Fifty-one days being added to 304, gave a year of 355 days, which, being an odd number, answered very well. But it was impossible to divide an odd number into twelve parts, all of which are odd, since twelve odd numbers added together would make an even number. One of the twelve months was doomed, by the very nature of things, and the laws of number, to consist of an even number of days. This unlucky number was, therefore, as a matter of course, assigned to February, over which the Genius of Death presided, and which was appropriated to the celebration of the Festival of the Dead. Hence it arose that February has the exceptional number of twenty-eight days.

Before we hastily visit with harsh censure this most absurd superstition, let us pause, and look at home, and see if we be

## COMMON THINGS—TIME.

ourselves totally exempt from ideas altogether as absurd, if not quite as mischievous. Who has not met with persons professing some claims to education and intellectual position, who object to a dinner party composed of thirteen, and to an odd number of candles being lighted on certain occasions? How many who would consider themselves insulted if they were charged with ignorance, object to start upon a journey, or to commence any serious enterprise on a Friday?

The difficulty of recollecting which months have thirty-one and which only thirty days, has been so generally acknowledged, that various technical aids to the memory have been contrived by which they may be at any moment ascertained.

If the months be reckoned in numerical order from the beginning of the year, the odd months, as far as the seventh, and the even ones afterwards, are those which have thirty-one days. Thus, they are the first, third, fifth, seventh, eighth, tenth, and twelfth, which are January, March, May, July, August, October, and December.

When we close the hand there are four projecting knuckles of the four fingers, with depressions between them. If we give the knuckles and intermediate depressions the names of the successive months, recommencing from the first knuckle, after having once gone over them, we shall find that the months of thirty-one days are those which fall upon the knuckles. Thus, the knuckle of the first finger is January, that of the second March, that of the third May, and that of the fourth July. Recommencing then, that of the first is August, that of the second October, and that of the third December.

Every one is familiar with the lines—

“Thirty days hath November,  
April, June, and September;  
February hath twenty-eight alone,  
And all the rest have thirty-one.”

64. The first day of a month was called by the Romans **CALENDS**, a name which was also applied to the months themselves. Hence it came that a table, showing for the current year the succession of months, and of the days in each month, came to be called a **CALENDAR**.

65. The name **Calends** was not used by the Greeks. Hence arose a saying when any thing was indefinitely adjourned, that it was postponed to the “Greek **Calends**.”

66. The seventh days of the four great months, as those consisting of thirty-one days were denominated, and the fifth days of all the lesser months, consisting of twenty-nine days, were called **NONES**.

## THE YEAR.

67. In like manner, the fifteenth days of all the great months, and the thirteenth of all the lesser months were called *IDES*.

68. The cause of this difference of position of the *ides* and *nones* in the greater and lesser months is to be found in the Roman custom of counting time *backwards*. Thus, in all months, greater or lesser, the *ides* were the seventeenth days, and the *nones* the twenty-fifth days, counting backwards from the last day inclusive.

It was not only the *nones* and *ides* themselves that were counted backwards, but also the intermediate days. Thus, in a month of thirty-one days, the first six days were called successively as follows :—

1st day	. . . . .	Calends
2nd ,,	. . . . .	Sixth before the nones
3rd ,,	. . . . .	Fifth " "
4th ,,	. . . . .	Fourth " "
5th ,,	. . . . .	Third " "
6th ,,	. . . . .	The eve of the nones
7th ,,	. . . . .	The nones.

In the same manner, the days succeeding the *nones* were counted backwards from the *ides*, and those succeeding the *ides* counted backwards from the *calends* of the next month.

Although carried to such an extent, the practice of backward reckoning was absurd; the method is, in certain cases, obviously convenient, and is still in general use. When remarkable festival days and anniversaries occur, we all find it convenient to name the preceding day their *eve*, and we even sometimes refer to the second or third day before such or such a remarkable epoch.

69. The periodic returns of the seasons taking place at intervals of about 365 days, could not remain long in accordance with a year of 355 days. This was soon perceived; and of all the inexplicable expedients of which the management of chronometric regulation affords any example, certainly the most curious by far was that by which it was attempted to bring the civil into accordance with the natural year.

Imperfect as the knowledge of astronomy was in these times, the mere observation of the returns of the seasons, such as all agriculturists in the rudest state would have made, was enough to show that 355 days was ten or twelve days less than the period of the seasons; and, therefore, that by continuing to count time by such a year, the seasons would return ten or twelve days later from year to year.

70. Numa, the successor of Romulus, who, as has been already stated, modified the calendar, decided that the civil year should be brought into accordance with the period of the seasons, by introducing into every other year a thirteenth month, called

## COMMON THINGS—TIME.

MERCEDONIUS, consisting alternately of twenty-two and twenty-three days. So far the expedient presented nothing very singular, but the manner in which this supplemental bi-annual month was introduced was most curious. It was decreed that the progress of the month of February in every other year should be suspended at the end of the twenty-third day, and that then the month Mercedonius should commence, and that, when it was completed, the month of February should be continued to its last day! Thus Mercedonius was wedged in between the 23rd and 24th of February. In these alternate years, the day after the 23rd February was the 1st Mercedonius, and the day after the 22nd or 23rd Mercedonius, as the case might be, was the 24th February, and the succeeding days the 25th, 26th, 27th, and 28th of February!!!

71. The term month has been used in different senses, one of which is the interval during which the moon makes a complete revolution round the earth.

Four weeks exceeding this interval by no more than sixteen hours, that period of time has been also called a month. According to Blackstone, this is the legal sense of the term, unless a different meaning be expressly given to it. A lease for twelve months is a lease for forty-eight weeks.\*

### VI.—THE YEAR.

72. This is the largest of the chronometric units, and is consequently that by which all long periods are expressed.

73. What is a YEAR? To most persons it may seem that such a question is superfluous, forasmuch as every one must very well know what a year is. If we press for an answer, and sift such as are given, the matter will not, however, prove to be so plain and so easy.

Some may reply that it is the interval of time during which the sun makes a complete revolution of the heavens.

Others will say that it is the interval determined by the periodical recurrence of the seasons.

The question would be stripped of part of its difficulty if these two intervals were the same. But they are not. If it be replied that their difference is not great, we may rejoin that the difference, however small it may be, will become great by accumulation, and that when the question relates to centuries it may be such as to throw the two definitions into utter discordance.

In explaining the circumstances attending the diurnal unit, we showed that one essential condition attending it was, that it should be invariable; in other words, that every succeeding day

\* Blackstone, ii. chap. 9.

## THE YEAR.

should have exactly the same length. The same condition is indispensable; and for the same, and even stronger, reasons in the case of the annual unit. Yet the natural standard from which that unit is taken, the periodical return of the seasons, like the periodical return of the sun to the meridian, is subject to a certain variation. It is on that account unsuitable for a standard measure of time. This defect, however, is removed by an expedient similar to that by which the mean solar day was substituted for the apparent solar day. A fictitious period is assigned to the return of the seasons, which is a mean between the extreme variations of the actual period which marks their successive returns, and this fictitious period, which is invariable and never differs much from the real period, being sometimes a little more and sometimes a little less, is adopted as the chronological year.

Unfortunately for the facility of chronology, however, neither this nor any other standard measure of time based upon the succession of seasons, consists of an exact round number of days without a fraction; nor has the fractional part remaining over a whole number of days the advantage of amounting by any extent of repetition to a day, or even to any whole number of days.

This circumstance, as will presently appear, has been productive of grave inconvenience in history and chronology.

74. In their first rough attempt at the establishment of the annual standard of time, the Egyptians gave the year 360 days, divided into twelve equal months of 30 days.

This is supposed to have been the origin of the division of the circle into 360 degrees, and indeed of the prevalence of a duodecimal modulus in many other popular measures.

The subsequent addition of the five complementary days is attributed to an Egyptian god or hero called by the Greeks HERMES, with the distinguishing appellation of TRISMEGISTOS, *thrice-greatest*.

75. This interval of 365 days was as near an approximation to the period of the seasons as could be made in round numbers. Nevertheless its continuance would, after the lapse of a certain time, have been the cause of inextricable confusion. Let us see whether we cannot make this apparent.

The true period marked by the return of the seasons is now known to differ from  $365\frac{1}{4}$  days by a little more than eleven minutes. This difference, minute as it is, has been the cause of great difficulties in history and chronology. Let us, however, for the present put it out of view, and take the year as being  $365\frac{1}{4}$  days exactly.

After the lapse of one year of 365 days the seasons would, therefore, return a quarter of a day later than in the preceding year. After another year of 365, they would return half a day

## COMMON THINGS—TIME.

later; after another, three-quarters of a day later; and after four years they would be an entire day later. Thus if spring began in the first year on the 21st March, it would begin in the fourth year on the 22nd March. In like manner it would begin in the eighth year on the 23rd, in the twelfth, on the 24th, and so on; being one day later every fourth year. In 30 times four years it would be a month later; and in  $182\frac{1}{2}$  times four years—that is in 730 years—it would be just six months later, so that Spring would commence on the 21st September, and Autumn on the 21st March. The first day of Summer would be 21st December, and the first day of Winter would be 21st June.

Such would be the ultimate effects ensuing from the adoption of a year of 365 days.

The confusion, historical and chronological, which would ensue from such a method of recording time must be obvious. If we found any event recorded in remote times which might have been affected by the season of the year at which it occurred, its date would supply no immediate indication of that. For anything indicated by the month in which it took place, it might have been in any season whatever, Spring, Summer, Autumn, or Winter. It is true, however, that the season might be discovered from the date, by calculating backwards, and allowing a day for every four years.

It is clear that after a period of four times 365 years—that is 1460 years—the seasons would return to the same days, having in the interval commenced upon every day of the year from the first to the last.

76. This discordance between the year of 365 days and the period of the seasons caused the former to be called the *Vague year*; the period of 1460 years, after which the seasons would return to the same days, was called the *SOTHIC PERIOD*, from some supposed relation to the *dog-star*, called *SOTHIS*.

77. However obvious were the objections attendant on the adoption of the year of 365 days it was not without defenders and partisans. The advantage claimed for it will, in our times, appear curious. It was said that such a year would cause all the festivals to fall successively upon every day in it, and would thus sanctify the entire year; just as if a Christian would at present advocate it on the ground that Christmas would in the course of fourteen or fifteen centuries fall upon every day in each season, of spring, summer, autumn and winter!

78. The Greeks, as we have seen, first measured time by months consisting alternately of 29 and 30 days, giving an average of  $29\frac{1}{2}$  days, a very close approximation to the true mean length of a lunation, and their year consisted of twelve such months. Such a year, however, consisting of only 354 days, deviated from the

## • THE YEAR.

periodic return of the seasons by more than eleven days, and after the lapse of no more than three years the seasons were put back more than a month; and after a period of eighteen years they were actually reversed, midsummer taking the place of midwinter, and *vice versâ*. The return of the seasons constituted so obvious and so natural a measure of the year, and was so intimately connected with the prosecution of human affairs, and especially with agriculture, that no measure of the year which varied so much from it could be long maintained; and, as we have already stated, attempts were soon made in all the provinces of Greece to bring the series of twelve months into accordance with the period of the seasons, by adjusting their several lengths so as to make a total of 365 days: an interval so near the true succession of the seasons that an age must elapse before any important discordance would have been rendered manifest.

Religious questions, however, intervened and raised serious difficulties among the Athenians. The festivals and ceremonies connected with the worship of the gods all originated at an early epoch when the lunar phenomena alone formed the basis of their chronology. Certain observances were required to be made in certain phases of the moon, and when those phases, by the changes in the lengths of the months, no longer recurred upon the same days of the year, but assumed a character similar to that of the moveable feasts of the Christian church, it became necessary in order to fix beforehand the times of their celebration, to calculate the days of the lunar phases, and, in a word, to create a calendar.

The difficulties which thus arose in the imperfect state of astronomical science at that epoch were seriously aggravated by a command proceeding from an oracle, to the effect that certain festivals appointed to be celebrated under particular lunar phases should be also held at certain seasons of the year. This at once rendered necessary the solution of the problem to bring into numerical accordance the series of lunations and the succession of the seasons, a problem which was at the time as far removed beyond the skill of the astronomers as that of the priests.

79. At length, about 432 B.C., Meton, an ancient astronomer, succeeded in obtaining a solution of it which, if not absolutely complete, was regarded as so satisfactory as to excite an outburst of popular enthusiasm. He stated that 235 lunations were exactly or so nearly equal to nineteen years that at the end of that period the full moons would again fall upon the same days of the year, and that, consequently, if the series of full moons were recorded for any single period of nineteen years, indicating the days upon which they severally took place in each year, they must recur upon the same days in every succeeding period of nineteen years,



## COMMON THINGS—TIME.

and must have in like manner occurred upon the same days in every past period of nineteen years. Thus all calculation of the recurrence of the lunar phases was rendered unnecessary. The lunar calendar of any interval of nineteen years was merely a reproduction of the lunar calendar of the preceding interval.

This period of nineteen years was, and is still, called the **METONIC CYCLE**.

80. This discovery which was made public by Meton on the occasion of the celebration of the Olympic games in 432 B.C., excited such unbounded enthusiasm and admiration, and the benefits it conferred upon chronology were so highly appreciated, that the numbers expressing the dates of the full moons in a cycle were ordered to be inscribed in letters of gold upon the public monuments, and upon tablets in the temples of the gods. It is to this circumstance that is ascribed the fact that these numbers were afterwards usually written in the almanacks in gilt characters, and later when printing had been invented, they were distinguished by being printed in red ink, and they thus acquired the name of golden numbers, by which they are distinguished in the calendars of the present day.

81. Neither the brilliancy of this discovery, nor the glory of the Olympic crown, nor the great popularity with which he was surrounded, protected Meton from the shafts of his illustrious contemporary Aristophanes, who attempted to turn him into ridicule and bring him into discredit by introducing him among a group of charlatans in the well-known comedy entitled "The Birds" (*Ὀρνιθες*).

82. It is a curious fact that the accordance of the succession of the lunar phases with the Metonic cycle has become more and more precise, as the motions of the sun and moon in the heavens have been more exactly ascertained. The mean length of a lunation, which was already known in Meton's time with great precision, is 29·530589 days, and consequently 235 lunations consist of

$$29\cdot530589 \times 235^d = 6939^d 16^h 31^m 19^s.$$

The mean length of the year, which was not so well ascertained in Meton's time, is now known to be 365·24224 days, or

$$365^d 5^h 48^m 49\cdot5^s,$$

and consequently nineteen such years consist of

$$(365^d 5^h 48^m 49\cdot5^s) \times 19 = 6939^d 14^h 27^m 41^s,$$

from which it appears that 235 lunations exceed nineteen years by 2<sup>h</sup> 3<sup>m</sup> 38<sup>s</sup>.

After each interval of 19 solar years, therefore, the successive lunations would commence 2<sup>h</sup> 3<sup>m</sup> 38<sup>s</sup> later.

83. It has been already stated that the Roman year consisting

## THE YEAR.

first of 304 days, was immediately increased to 355 days; and that ultimately, by the complementary month called *Mercedonius*, 45 days were added to every fourth year. Thus each series of four years consisted of

	DAYS.
I. . . . .	355
II. . . . .	355
III. . . . .	355
IV. . . . .	400
	1465

So that the four years consisted of 1465 days.

The true length of four solar years being, however, only 1461 days, four Roman years as thus established would be four days too long; so that every four years the seasons would fall four days earlier in the year, and in the short period of thirty years, they would be severally moved back a month.

84. This consequence being soon rendered apparent, a remedy for it became necessary, and that which was first adopted was one of the worst expedients that could have been imagined. A discretionary power was given to the pontiffs to intercalate as many days as they might consider necessary to bring the year into accordance with the succession of seasons.

As might have been foreseen, this measure speedily gave rise to the most gross system of abuses. Accounts being made up, payments made, and interest computed for all affairs private and public to the first days of the months, the pontiffs prostituted the powers conferred upon them to the most corrupt purposes. The temporary magistracy of those whom they favoured was prolonged, and that of those whom they opposed was abridged; payments to be made by their friends were postponed, those due by their opponents accelerated; the profits of the farmers of the revenue were augmented or diminished at their good will and pleasure, by the adroit management of the arbitrary intercalary days by which they were enabled to prolong or to abridge any months of the years. The disorders thus produced attained at length to such a pitch, that the festivals of autumn were celebrated in spring and *vice versâ*.

### VII.—THE JULIAN REFORM.

85. It was reserved for Julius Cæsar not only to put an end to this confusion and the abuses in which it originated, but to establish a system of recording time, which has come down to our own epoch, and is denominated from its founder the *JULIAN CALENDAR*. He was aided in this great reformation by *Sosigenes*, an eminent

## COMMON THINGS—TIME.

Egyptian astronomer of that day. He was, according to the laws, authorised to accomplish this, being himself chief pontiff.

Astronomical science had so far advanced, that the length of the period determined by the succession of the seasons was known to be about  $365\frac{1}{4}$  days. But the adoption of a civil year conforming to this would have involved consequences of a highly impracticable kind. Thus, if we suppose such a year to commence at midnight, between the 31st December and 1st January, the succeeding year would commence at six A.M. on the next 1st January; the next at noon, on the following 1st January; the next at six P.M., on the 1st January of the third year; and, in fine, the next at the midnight between the 1st and 2nd January on the fourth year. Thus, in a series of four years, the first day of January would be transferred piecemeal, quarter by quarter, backwards to the preceding year.

This was evidently an impracticable measure. Julius Cæsar, who in the eminently practical character of his genius closely resembled Napoleon, resolved upon surmounting the difficulty by an expedient as simple in its execution as it was happy in its conception.

86. It was decided to adhere to years consisting of a whole number of days, and to allow the fractions to accumulate from year to year, until they should make up an entire day, and then to add that as a supplemental day to the year in which the accumulation should arrive at its limit. Since therefore the fraction over the round number of 365 days was assumed to be a quarter of a day, it would at every fourth year amount to a day. It was, therefore, decided to accomplish the object by giving one additional day to such fourth year. These four successive years were to be thus composed:—

I. . . . .	d. 365
II. . . . .	365
III. . . . .	365
IV. . . . .	366
	1461
Mean length . . . . .	$365\frac{1}{4}$

The object was, therefore, attained without annexing fractional parts of a day to the year.

The additional day given to the fourth year was introduced into the month of February, making that month 30 instead of 29 days.



## COMMON THINGS.

### TIME.

#### CHAPTER IV.

87. Year of confusion.—88. New arrangement of the months.—89. Mistake of the Pontiffs.—90. Leap-years.—91. Historical dates.—92. Day of the equinox.—93. What is the equinox?—94. The two equinoctial points.—95. Sidereal year.—96. Precession of the equinoxes.—97. Equinoctial year.—98. Civil year.—99. Difference between it and the Julian year.—100. Effect of this difference.—101. Cause of the reformation of the Calendar.—102. Discordance between the real and ecclesiastical equinox.—103. Gregorian reform.—104. Gregorian Calendar.—105. Its compensating effect.—106. Resistance to its adoption.—107. Dates of its adoption in different countries.—108. In England.—109. Its reception there.—110. Occasional agreement of the new and old styles.—111. Anecdotes relating to the change.—112. Russia adheres to the old style.—113. Commencement of the year.—114. Various in different countries.—115. In England.—116. Old and new style in England.—117. Temporary inconvenience attending it.

## COMMON THINGS—TIME.

It will be remembered that the Romans counted the days of the month backwards, and that those of the latter part were reckoned from the calends or first day of the next month. Now it happened that the sixth day of February, counting backwards from 1st March, called the sexto-calendas was consecrated to a festival celebrating the expulsion of the Tarquins. It was resolved to place the supplementary day of the fourth year immediately before this sexto-calendas, and to avoid changing the denomination of the other days it was decided to call it a second sexto-calendas. It was therefore denominated **BISSEXTO-CALENDAS**, and the year in which this additional day was intercalated was and still is called **A BISSEXTILE YEAR**.

The commencement of the year was ordered to take place on the day of the new moon, which occurred next after the winter solstice of the preceding year. This day was accordingly called the 1st January, 709, from the foundation of Rome, and as the commencement of our era was the year 754 from the foundation of Rome, it follows that the date of the Julian reform was 45 B.C. and consequently the year preceding the murder of Cæsar.

87. This admirable arrangement provided for the future, but it did not repair the consequence of the past abuse and disorder. The complementary month called Mercedonius had been the subject of constant maltreatment by the pontiffs, having been abridged and extended in the most capricious and arbitrary manner, so as completely to derange the position of the seasons, relatively to the commencement and the close of the year. To rectify this some bold and exceptional temporary measures were indispensable. Cæsar being chief pontiff exercised the power which his predecessors in that office had so grossly abused to rectify these disorders, and restored by a violent and exceptional measure the day of the spring equinox to the 25th March, the date which it held in the time of Numa. To accomplish this, he decreed that the year 708 from the founding of Rome should consist exceptionally of 445 days. These 445 days were composed in the following manner:—

	Days.
The common year . . . . .	355
Month Mercedonius . . . . .	23
Two extraordinary months between November and December :	
First . . . . .	33
Second . . . . .	34
	445

The year in which these changes were introduced came to be called the “**YEAR OF CONFUSION.**” This year was 46 B.C.

88. Besides thus re-adjusting the place of the equinoxes, the

## THE JULIAN REFORM.

distribution of the 365 days among the twelve months was re-arranged. It was ordered that the odd months, counting from the beginning of the year should contain 31 days each, and that the others should contain 30, except February, which in common years was to contain 29, and in bissextile years 30 days.

This natural and easily remembered distribution was disarranged soon after to gratify the frivolous vanity of Augustus. It has been already stated that the month Sextilis had its name changed to Augustus in compliment to that emperor. Not satisfied with thus having his name perpetuated, he insisted that the number of days in his month should not be less than in Cæsar's. The day added to August was therefore taken from February, which was thus reduced to 28 days for common, and 29 for bissextile years. The months definitively stood as follows:—

	Days.		Days.
January . . . . .	31	July . . . . .	31
February . . . . .	28 or 29	August . . . . .	31
March . . . . .	31	September . . . . .	30
April . . . . .	30	October . . . . .	31
May . . . . .	31	November . . . . .	30
June . . . . .	30	December . . . . .	31

The alternation of 30 and 31 days proposed by Cæsar is therefore preserved with the exception of July and August, two months of 31 days in immediate succession.

It was attempted at later periods of the empire to prostitute the calendar by changing the names of the latter months of the year into those of Tiberius, Claudius, Nero, and Domitian; but the good sense of the Roman public resisted such an ignominy.

89. The death of Cæsar in the year after this reform had been decreed, threw the task of its realisation into the hands of the pontiffs, whose very first act betrayed a total misapprehension of the meaning of the most important of the conditions of the new system. The terms of the Julian edict, by which the recurrence of the bissextile year was defined, have not come down to our times; but it is certain that the pontiffs interpreted the periodic addition of the intercalary day as designed for every third year, and not every fourth year. That they were not set right by any contemporary authority like Sosigenes, who, knowing the object to be accomplished by the expedient, might have demonstrated the sense of the edict, if the words in which it was expressed were equivocal, only shows in a striking point of view how rare this sort of knowledge must have been in that age. However, it is certain that for the first 36 years after the reformation, every third, instead of every fourth year, was taken as a bissextile year, and consequently that these 36 years, including 12 instead of 9

## COMMON THINGS—TIME.

intercalary days, had a total length greater by 3 days than was due to them by the Julian system rightly understood. When this error was at length perceived, the consequence of it was rectified by order of Augustus, who decreed that for three successive periods of four years, the intercalary day due to every fourth year should be omitted, so that the excess given to the preceding 36 years was compensated by an equal deficiency in the 12 following years, after which the regular recurrence of bissextile years was observed.

The mistake is known to have arisen thus--In Roman counting, every *fourth* is our *third*,

			1	2	3	4				1	2		
A	B	C	D	E	F	G	H	I	J	K	&c.		
			1	2	3	4				1	2	3	4

Livy describes the cycle of 19 years as *one which* begins every *twentieth* year.

90. The common name given to bissextile years in our language is LEAP YEARS, which the dictionaries explain by stating that "every fourth year leaps over a day more than a common year." It is, however, objected by some that the term LEAP year is inappropriate, inasmuch as leaping over a day would imply its omission, instead of which in such years an extra day is thrust in.

The term is also explained by stating, that it implies that a day is leaped over in the calendar without giving it a distinct name.

It is worthy of remark that in the ecclesiastical calendar of foreign countries, the day called "intercalary" in bissextile or leap years, is not the 29th but the 24th of February.

91. It will be perceived from what has been stated, that some confusion prevailed for nearly forty years from the date of the Julian reform, that is until very near the commencement of the Christian era; nor is there any historical certainty as to the regular observance of the new method until the commencement of our era. It is certain, however, that the Roman years 761, 765, 769, &c., which were the years A.D. 8, 12, 16, &c., were counted as leap years, and about all succeeding dates there is no doubt.

From these dates, historians and chronologists have reckoned not only forwards but backwards, so as to reduce all historical events to the position in respect to the order of time which they would have held, if the Julian system had always existed. When we read of historical events, occurring in distant ages before these reforms in the methods of recording time, we are to understand that the dates assigned to them are by no means those which they bore at the time, and in the nation of their occurrence; but that by the labours of chronologists, the local dates given to them by

## LEAP YEAR.

the contemporary annalists, dates varying not only in different countries according to their different usages, but even in the same country in different ages, have been changed into those dates which they would have had if the Julian chronology had prevailed then.

It is evident that without this simplification and assimilation, historical dates would present a mass of confusion, which would be inextricable to all ordinary readers.

92. It has been already stated that the interval of  $365\frac{1}{4}$  days, assumed in the Julian reformation as the length of a year, is not its true length, but differs from it by a very small fraction of a day. As we have now to explain the part which this very minute fraction has played in chronology, it will be necessary to convey to the reader a more clear and distinct notion of the meaning of the word *year*, than that which is included in the general statement that a year is the period after which the seasons are reproduced; for it may fairly be asked what determines the limits of the seasons? how are the exact moments of time at which they severally begin or end defined? For it must be observed that our enquiries now involving not whole numbers of days, but small fractions of a day, it is not enough to know that this or that season begins or ends on this or that day; we must know the hour, minute, second,—nay even the fraction of a second, which marks the epoch we desire to determine.

It is customary then to define the course of the seasons by the moment at which spring begins. It has been agreed to take for this the moment at which the centre of the sun's disc has such a position in the heavens, that if it were stationary there, day and night would be exactly equal, that the sun would be in short exactly twelve hours visible, and twelve hours invisible; twelve hours above, and twelve hours below the horizon.

It may be said that this definition is needlessly verbose and complex, inasmuch as it would be more simple and intelligible to say at once that spring begins *on the day of the equinox*.

Undoubtedly such a summary statement would be much shorter and more simple, and provided that it be clearly understood, and that it be sufficiently definite, it can be subject to no objection. But what is meant by the "day of the equinox?" We shall, of course, be answered that it is that day on which the sun is twelve hours above, and twelve hours below the horizon.

Very well! let us go to the almanac, and search for such a day. We take the almanac of 1854, and find that on 19th March the sun was twelve hours and one minute above, and eleven hours and fifty-nine minutes below the horizon. On the 20th it was twelve hours and six minutes above, and eleven hours



## COMMON THINGS—TIME.

and fifty-four minutes below the horizon, while on the 18th it was eleven hours and three minutes above, and twelve hours and fifty-seven minutes below the horizon. On no day of the month was it exactly twelve hours above, and twelve hours below the horizon; and the same result would be found by examining in the same manner the almanacs for other years.

It appears then that rigorously equal day and night is a phenomenon that never exists. It is no answer to this to say that the day and night in the instance produced and others differ only by a minute or two, because the question here involves only the consideration of those very minute intervals.

Since then the "day of the equinox" cannot mean a day on which day and night are equal, what is its exact meaning? We reply that it means very obviously the *day on which the equinox takes place*. But then what is in that case meant by the word equinox? We reply by turning back upon the explanation already given, that the equinox is that precise moment when the centre of the sun's disc has such a position that, supposing it to retain that position unchanged, it would be twelve hours above, and twelve hours below the horizon, during a revolution of the heavens.

93. But since the sun's disc has a continual easterly motion upon the heavens, moving at the rate of nearly  $1^\circ$  per day, or  $2\frac{1}{2}'$  per hour, it does not retain the position in question more than an instant. It moves round the heavens as the hand of a clock moves round its dial, passing incessantly from point to point. The exact point at which the centre of the sun is at the moment above described, is therefore called the equinoctial point, as the moment of time at which it passes through that point is called the equinox.

94. There are two equinoxes and two equinoctial points. The first takes place about the 21st March, and the other about the 23rd September.\*

The former is called the vernal equinox, and the latter the autumnal equinox, because it has been agreed to fix the beginning of spring at the one epoch, and the beginning of autumn at the other.

The two equinoctial points are situate at opposite sides of the heavens, separated one from the other by an entire hemisphere, as must be evident when it is considered that the sun takes six months to move from the one point to the other.

95. Having thus conveyed a distinct notion of the meaning of the equinoxes, and of the equinoctial points, we shall find less

\* In the tables of sunrise and sunset given in the almanac, the effects of refraction are taken into account. These are omitted, however, in fixing the position of the equinoxes.

## THE EQUINOXES.

difficulty in explaining the different senses in which the word YEAR is used.

If the equinoctial points maintained a fixed position on the heavens, the interval between the moments at which the centre of the sun's disc would pass twice successively through either of them, would be in fact the interval during which the sun makes or appears to make a complete revolution of the heavens.

This interval is called the SIDEREAL YEAR.

Astronomers have ascertained the exact length of this year to be  $365^d 6^h 9^m 10.38^s$ .

It appears, therefore, that this long interval has been ascertained to within the hundredth part of a second of its true value.

96. But the equinoctial points have not a fixed position on the heavens. They are on the contrary, subject to a slow displacement from year to year in a direction contrary to the motion of the sun. The amount of this annual displacement is small, being a little less than one minute of a degree,—that is, about the thirtieth part of the breadth of the sun's disc.

Small as this displacement is, it has been very precisely measured; and its effects, which are of the highest importance, as well in chronology as in astronomy, have been exactly appreciated.

On account of this removal of the equinoctial point backward, the sun arrives at it after making a revolution of the heavens, sooner than it would have done if it had not been displaced. This must be evident when it is considered that the equinoctial point, displaced in a direction contrary to that of the sun's motion, advances to meet the sun on its return. The sun therefore arrives at it before it makes a complete revolution of the heavens, and the time of each successive equinox *precedes* the time at which it would have taken place if the equinoctial point had been stationary.

This phenomenon has for that reason been called the PRE-CESSION OF THE EQUINOXES.

97. The effect therefore obviously is, that the interval between two successive equinoxes is less than the sidereal year.

This interval between two successive equinoxes is called the EQUINOCTIAL OR TROPICAL YEAR.

The sidereal year is of invariable length, and would on that account be well suited to be a standard measure of time. But it has one capital defect, which renders it totally unfit for civil purposes. It is not in accordance with the periodic returns of the seasons by which all mankind measure the year.

If the equinoctial points were stationary, the sidereal year would also be the equinoctial year, and in that case it would be coincident with the return of the seasons. But in consequence of

## COMMON THINGS—TIME.

the displacement of the equinoctial points, the commencement of the equinoctial anticipates that of the sidereal year; the extent of this anticipation, though very small at first, accumulating for long series of years, causes the seasons to take place successively at all imaginable parts of the sidereal year.

For these reasons the sidereal year has never been adopted as the civil year.

If the annual displacement of the equinoctial point were regular and constant, the precession of the equinoxes would be also constant; and the equinoctial year, differing from the sidereal year by an invariable quantity, would itself be invariable, and as it is in accordance with the succession of the seasons, it would be in all respects eligible as a standard measure of civil time.

But it so happens that this displacement is rendered variable by the operation of several causes. Its variations, however, are circumscribed within narrow limits. It alternately increases and decreases, and has a certain ascertainable average amount. On account of this variation, the equinoctial year is of slightly variable length, and is therefore not fit for a standard measure of time.

98. This being the case, and the mean annual displacement of the equinoctial point being accurately ascertained, a fictitious equinoctial point is supposed to exist, which has this mean annual displacement, and the interval between two successive returns of the sun to this fictitious equinoctial point being invariable, is adopted as the standard, and is called the **MEAN SOLAR OR CIVIL YEAR**.

Although rigorously this year does not therefore correspond with the returns of the seasons, it never varies from them by any interval great enough to be perceived or appreciated by any but astronomers.

The exact length of the mean solar or civil year is

$$365^d 5^h 48^m 49^s \cdot 54,$$

being less than the sidereal year by  $20^m 20^s \cdot 8$ .

99. Such being then the actual length of such a year as would always remain in accordance with the successive returns of the seasons, let us see to what extent the year of the Julian calendar differs from it, and how such difference would affect chronology.

The Julian year being  $365\frac{1}{4}$  days, the difference between it and the mean solar year is easily found.

	D.	H.	M.	S.
Julian year . . . . .	365	6	0	0·00
Mean solar year . . . . .	365	5	48	49·54
Difference . . . . .			11	10·46

100. It appears, therefore, that the Julian years would depart from the course of the seasons at the rate of  $11^m 10^s \cdot 46$ , or about

## THE GREGORIAN REFORM.

the 129th part of a day per annum. The departure accumulating from year to year would amount to a whole day in 129 years, to two whole days in 258 years, to three in 387 years, and so on.

Now, although such a departure would not be perceptible during the lives of a single generation, it must evidently become so after some centuries. The equinox falling back towards the beginning of the year at the rate of one day in 129 years, was in the fifteenth century thus thrown back as much as eleven days.

It is evident that the continuance of this from century to century would have thrown the equinox back from day to day until it, and consequently the seasons, would have successively assumed every possible position in the year.

### VIII.—THE GREGORIAN REFORM.

101. Although in a more civilised and enlightened age this would have been a reason sufficiently urgent to undertake a revision and correction of the calendar, we are indebted for the reform which took place to other and different causes.

102. It was the rule of the Church to celebrate the festival of the Resurrection at a time not far removed from the 21st March, which was taken to be the day of the equinox, depending however also upon conditions connected with the lunar phenomena with which we are not at present concerned, but which we shall explain fully on another occasion. If therefore the real equinox were subject, as we have stated, to a gradual change, which would throw it back from year to year, so that it would fall each successive year earlier and earlier, while the festival of Easter, still related to the 21st March, would necessarily be farther and farther removed from the equinox, it must obviously happen in the course of time that the festival would fall successively in every season of the year, and indeed on every day of the year.

The Roman ecclesiastical authorities of the day becoming painfully aware of this, and sensible that no decree of pope or council could accelerate the motion of the equinox for the future, or carry it forward from the 11th to the 21st March; to repair the error of the past, resolved that since they could not bring the equinox to the 21st March, they would bring the 21st March to the equinox.

103. This change, with the others necessary to prevent the recurrence of a like discordance between the ecclesiastical year and the seasons, took place in the latter part of the sixteenth century, in the pontificate of Gregory XIII., from whom the reformed calendar came to be called the Gregorian calendar.

As at the epoch of the Julian reform, two errors were to be corrected, those of the past and those of the future. The accu-

## COMMON THINGS—TIME.

mulated effect of the past errors was that the real epoch of the spring equinox had fallen ten days behind the nominal day of its occurrence, which was the 21st March. The future cause of error was that an additional day every fourth year was too much, but that 129 years must elapse before the redundancy would cause the equinox to be one day behind its time.

104. To remedy the consequence of past errors, it was decreed that the days of the months should be all expressed by numbers, greater by 10 than those by which, according to the succession of time, they were expressed. Thus the 11th March, 1582 (the year in which the reform took place) was decreed to be the 21st March, and in like manner all the other days of the year were augmented by 10. By this expedient the last ten days of 1582 were thrown over into 1583, inasmuch as the 21st December, 1582, became 31st December, 1582, and consequently 22nd December, 1582, became 1st January, 1583.

The day of the vernal equinox thus recovered the date of 21st March. How it was secured in the undisturbed possession of that date, we shall now see.

By following the established rules of the Julian calendar, it would have been one day behind its date in 129 years from 1582, that is in 1711. To prevent this, it was decreed that the year 1700, which would by the Julian calendar be a leap year, should be a common year. One day being thus omitted, the equinox of 1711 would be restored to its date of 21st March. In like manner it would be again a day behind in 1840. This was in like manner to be prevented by making 1800 a common year, which ought to be a leap year. Again it would be a day behind its time in 1969, which would be set right as before by making 1900 a common instead of a leap year. Another period of 129 would go to 2098, which was remedied by making 2100 a common instead of a leap year.

Thus the equinox would be kept right by making three successive secular years 1700, 1800, and 1900 common years instead of leap years, leaving 2000 a leap year, but making 2100 a common year instead of a leap year, and going on from century to century in the same manner, leaving every fourth secular year a leap year, but making all the others common years. The series of secular years would therefore be as follows :—

1700 Common	2300 Common
1800 „	2400 Leap
1900 „	2500 Common
2000 Leap	2600 „
2100 Common	2700 „
2200 „	2800 Leap,

## THE GREGORIAN REFORM.

and so on. The secular leap years will always be those of which the first two figures are exactly divisible by 4 without a remainder, as 2000, 2400, 2800, 3200, 3600, &c., all the other secular years being common years.

105. Let us see whether the compensation thus produced for the errors of the Gregorian calendar is practically sufficient, for perfect it is not, nor is it possible for any such compensation to be so. It has been shown, that the Julian year was too long by the 129th part of a day very nearly. To compensate for this Pope Gregory XIII. does what? He takes away three days from 400 years, which is equivalent to taking  $\frac{3}{400}$ th part of a day from one year, whereas the quantity required to be deducted is the 129th part of a day, which is greater than the  $\frac{3}{400}$ th part. The compensation of Pope Gregory is therefore short of the requisite quantity by the difference between the 129th and the  $\frac{3}{400}$ th part of a day, that is by the 3969th part of a day.

Thus it appears that by following the Gregorian calendar the equinox will not be so much as one day behind its time until an interval of 3969 years elapses, counting from the year 1582, that is until the year of our Lord 5551. When that time arrives the evil may be staved off for another period of 3969 years, by declaring the year 5600 a common, instead of a leap year. We may, however, safely leave to the inhabitants of the earth at that epoch the management of the affair. Sufficient for the day is the evil thereof.

106. Notwithstanding the undeniable reasonableness of this reform of the calendar, and the manifest absurdity of persevering in calling the 21st March the vernal equinox, when all the world had the evidence of their senses to prove to them that the equinox had really taken place ten days earlier, the change proposed was not generally adopted. Protestant States were opposed to it because it emanated from Catholic ecclesiastical authorities, and as was wittily observed, they preferred rather to be in opposition to the sun than in accordance with the Pope. The nations professing Greek Catholicism were opposed to it because it emanated from the head of the branch of their Church which they denied to be orthodox.

The papal decree fixed the exact date of the commencement of the reform at the 5th October, 1582, according to the former style, which day was decreed to be called the 15th October.

107. In France the change was adopted on the 10th December, next following, which was called 20th December.

In the Catholic States of Germany it was adopted in 1584.

The Protestant German States, having resisted the reform for nearly twenty years, at length yielded, and accepted it in 1600, in which year the 19th February was declared to be 1st March.

## COMMON THINGS—TIME.

Denmark, Sweden, and Switzerland, were later in the adoption of the change, but soon followed the example of Germany. Some Swiss towns nevertheless offered such vigorous opposition to the measure, that the intervention of the military was necessary to enforce it when adopted by the authorities.

In Poland, where it was adopted by the government as early as 1586, it encountered considerable opposition in certain towns, and even excited a serious insurrection at Riga.

108. The anti-papal spirit being much more dominant in England than common sense or scientific authority, the reform was resisted for nearly two centuries, so that the real had fallen above eleven days behind the legal date of the equinox. In 1752, however, the force of things at length prevailed over this discreditable bigotry, and the reform was introduced into the calendar, by declaring the 3rd to be the 14th September.

109. A measure of which the effect was to overturn the long established landmarks of time, and to substitute for them others, new and altogether strange to tradition and usage, could not be supposed to pass without exciting many reclamations among persons of all classes from the peer to the peasant. Personal feelings were excited at the unceremonious perturbation of birthdays and of marriage anniversaries. Religious exasperation was produced by the arbitrary transposition of the most solemn festivals. Even the moveable feasts already surrounded with some confusion, became for the moment confusion worse confounded. Political celebrations and the dates of historical events shared in the general disturbance.

In an essay on the ecclesiastical calendar, by Professor De Morgan, which was published in the Companion to the British Almanac, for 1845, some amusing examples of this are collected. A friend of the author, an eminent scientific man, not long since deceased, related of his own knowledge, when a boy, that a worthy couple in a country town, scandalised at the change of style in 1752, continued to attempt the observance of Good Friday on the old day. To this end they used to walk seriously, and in holiday costume, to the church door, at which the gentleman used to knock for a certain time with his cane, demanding admittance. On finding no admission, they walked as solemnly home again, and read the Church service appointed for the day. On the new and, as they regarded it, spurious Good Friday, they ostentatiously acted as if it either preceded or followed the genuine day, as the case might be, so as to render it manifest to their neighbours and friends, that they at least totally rejected the new style.

110. In the 48 years, between 1752, the date of the change of

## POPULAR SUPERSTITIONS.

style, and the end of the century, there were, however, 18 years in which harmony must have been re-established between the partisans of the new style and those who revered tradition, for in these years it chanced that the moveable feasts, according to both styles, fell upon the same days. "This," observes Professor De Morgan, "happens still occasionally, and will do so, though less and less frequently, until 2698 A.D., when it will happen for the last time."

Even still, after the lapse of more than a century; the Christmas Day of the old style is celebrated under the name of Twelfth Day, and the name of "Old Christmas Day" is still given to it in the calendar. It falls on the Feast of Epiphany.

111. Before the change of style, a popular belief prevailed in England, that at the moment of the midnight with which Christmas Day began, the cattle always fell on their knees in their stalls. Now when the change of style took place, it could scarcely have been expected that the arbitrary will of the legislature would be respected by these dumb animals, and it was accordingly found that they continued to perform the act of reverence, not on the Christmas Day of the law, but on that of the old style! The best of this joke was, however, that the Christmas Day of the law was a Popish institution, forced upon England by circumstances, and it was maintained that these Protestant cattle were all the more obstinate in their dumb protestation against the Romish innovation.

It appears, nevertheless, that in Catholic countries which acknowledged the authority of the See of Rome, in changing the style in 1582, inanimate things, not to say cattle, acknowledged the validity of the decree; for we have the high authority of the truly learned Riccioli, to whose astronomical works the scientific world is so largely indebted, to assure us that the blood of St. Januarius, which previously used to liquefy punctually on the 19th September, immediately changed the day of its miraculous liquefaction to the 19th September of the new style, which was the 9th September of the old style. Like the day of the nominal equinox, that of the miracle was accordingly put back ten days, in obedience to the papal bull.

Riccioli also mentions the case of a certain supernatural twig, which had been accustomed to put forth miraculous buds on Christmas Day. This Romish twig, unlike the Protestant cattle, as the astronomer assures us, was found to bud on the new Christmas Days which followed the publication of the Papal bull.

112. Of all Christian States, Russia alone still insists on adhering to the Julian calendar, and accordingly, by the further



## COMMON THINGS—TIME.

accumulation of the effects of the erroneous length assigned to the year, the Russian legal equinoxes are now *twelve* days in advance of the real equinoxes.

113. The influence which long continued usage exercises upon the mind is such that we are always disposed to think, that what has been long established has been so by the nature of things, and therefore of necessity, and not at all by the arbitrary appointment of local and temporary authorities, or by the voluntary choice of the people. Thus, who does not imagine that it is for some natural and necessary reason that the year begins on the 1st of January? January is the first of the series of twelve months, and what can be more natural than to take its first day as the commencement of the year? But why is January the first month? It is marked by no peculiar or universally observable phenomenon. If the sun, on its first day, were seen to occupy any remarkable position, as, for example, that which it has at the equinox, or if the sun and moon were always found together on that day, or if a conspicuous eclipse, or any other striking phenomenon periodically presented itself on that day, a reason would be found why January is the first month, and why its first day is the first day of the year. But neither the month nor the day is signalled by such phenomena, nor by any which can be supposed to mark it by nature as the commencement of a chronometric period.

It might be imagined that at all events the first day of *some* month would be selected as the commencement of the year. No reason, as it would appear, could induce people to begin the year in the middle of a month, so that one part of that month should be in one year and the remainder in the other. Nevertheless, obvious as these considerations now appear, it is certain that they have had no weight with mankind. Other considerations of another order, exercising over the mind much more potent influences, have predominated, and years, accordingly, with different nations and in different ages, have had their commencement fixed upon days which have no reference either to astronomical phenomena, or the order or limits of the months.

114. Religious anniversaries, as might naturally have been expected, have played a prominent part in this chronological element. Christmas Day, Easter Day, and the Festival of the Annunciation, commonly called Lady Day, have been, in different countries and at different ages, selected as the first day of the year. Among the French, at the time of Charlemagne, the year commenced on Christmas Day. It commenced on Easter Day among the same people under the Capet monarchs, and this practice was very general in the twelfth and thirteenth centuries. In

## CHANGE OF STYLE.

England the year commenced on Lady Day (25th March) until 1752.

It must not be understood that this commencement of the year involved any change either in the months or in the order of their days. Thus when the year commenced on Christmas Day, that day was still called the 25th December, and was preceded by the 24th and followed by the 26th December; but the 24th December belonged to one year and the 25th to the next. In like manner, the two days which we now refer back to as the 24th and 25th March, 1751, were, at the time they actually occurred, called the 24th March, 1750, and 25th March, 1751. Thus 24 days of March belonged to 1750, and the remaining 6 days to 1751.

115. To us at present, with the habits of counting the years, months, and days to which we have been accustomed, such a method of commencing the years appears so absurd and attended with such strange confusion and disorder that we find it difficult to imagine how a people could ever continue the practice of it. Nevertheless it is certain, so far from any such impression existing at the time this usage prevailed, the announcement of the change of style, as it was called, which was decided upon by the legislature in 1751-2, encountered the most serious resistance, and excited popular disturbances of grave importance. The transfer of the beginning of 1752 from the 25th of March to the 1st of January, immediately preceding it, deprived the year 1751 of the months of January, February, and twenty-four days of March, nearly the whole of its three last months.

This change and the apparent sponging out from the course of time of eleven days exasperated the populace, who, assembled in the streets of London, and pursued the members of the government (among whom was the celebrated Lord Chesterfield) when they appeared, with cries and imprecations, demanding that their eleven days should be given back to them.

The traces of this custom in our country are still apparent in various practices. Leases are commenced and determined by Lady Day. The quarter days on which rents become due are regulated in the same manner. All rents are payable on Lady Day and Michaelmas Day, and not, as might naturally be expected, on the last days of June and December.

116. Until the adoption of the Gregorian calendar in England in 1752, the years, as has been already stated, commenced upon the 25th March, so that the year 1751 began on the 25th March, 1751, and ended upon the day now called the 24th March, 1752, while the year 1752 ended on the day now called the 24th March, 1753. Independently of the other obvious objections to such a system, it was out of all accordance with the mode of reckoning time prac-

## COMMON THINGS—TIME.

tised by other nations of Europe, and great inconvenience and some confusion prevailed in the adjustment of dates in all international transactions. It was therefore resolved to include in the reformation of the calendar the change of the commencement of the year, from the 25th March to the 1st January, which was accomplished by declaring that the days, from the 1st January, 1751 (as formerly counted) should be taken as belonging to 1752, and that 1752 should end on the 31st December, and 1753 begin on the day formerly called the 1st January, 1752. Thus, in fact, the months of January, February, and twenty-four days of March, were transferred from each year to that which succeeded it.

This will explain the peculiar way of expressing dates which is found in all documents and printed works which appeared at, and for some time after the reform was adopted. Both dates, the new and the old, according to the reformed and unreformed style, were usually expressed, the old above and the new below a line, like the numerator and denominator of a fraction. Thus, for example, the day which was the 19th June, 1753, in the old style, being the 30th June, 1753, in the new style, the date was written thus,  $\frac{19}{30}$  June, 1753. In other cases the month was changed as well as the day; thus the day which was the 30th June, 1753, old style, became the 11th July, new style, and the date was written

$\frac{30\text{th June,}}{11\text{th July,}}$  1753.

In other cases again, the day, month, and year were all changed, as, for example, the day which, in the old style, was the 23rd February, 1753, in the old style, became the 6th March, 1754, in the new style, and was thus written:—

$\frac{23\text{rd February,}}{6\text{th March,}}$  1753.

117. The difficulties which such a change at first produced among the great mass of the population of the country, who, from their limited education and information, must have been unaware of the many important grounds on which the reform was based, can be easily conceived.

Happily, however the reform was realised, and the inconveniences which first attended it disappeared after a few years, so that the English dates were not only brought into accordance with the course of the seasons, but with those adopted by other civilised nations.

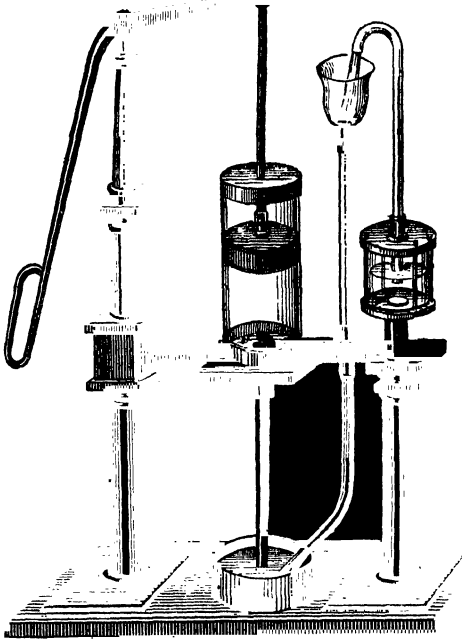

FORCING PUMP.

## COMMON THINGS.

### PUMPS.

1. Earliest methods of raising water.—2. Bucket in a well.—3. By windlass and rope.—4. By two buckets balanced over a pulley.—5. Method of working these by animal power.—6. The rope in this case balances itself.—7. The lifting pump.—8. Double lifting pump worked by animal power.—9. Various forms of valves.—10. Clack valves.—11. Conical spindle valves.—12. Ball valves.—13. The suction pump.—14. Analysis of its action.—15. Forcing pump.—16. Same with air vessel.—17. Same with solid plunger.—18. Double action forcing pump.—19. Garden watering pumps.—20. Fire-engine.—21. Chain pump.—22. Drainage of mines.

1. As water is one of the most universal necessaries of life, and abundant as it is in nature, is not always found in the localities where circumstances oblige us to fix our habitations, expedients by which it can be obtained in sufficient quantity, and of the

## COMMON THINGS—PUMPS.

necessary purity, have been among the earliest mechanical and physical inventions in every country. Natural springs showed that sources of water existed in the lower strata of the earth. This suggested the process of well-sinking or boring for water. But the water when thus found rarely rises to the surface spontaneously. It does so in those deep springs called artesian wells; but in all ordinary cases where a shaft has been sunk deep enough to find water, the water collects in the bottom of the shaft, and never rises above a certain level. Expedients are therefore necessary in all such cases to raise it to the surface.

2. The first and rudest of these contrivances, is to let down a bucket by means of a rope, and thus to draw up one bucket-full after another. The rope by which the bucket is elevated, when the well is not very deep, is sometimes attached to the long arm of a lever (fig. 1) the shorter arm being pulled down when the bucket is drawn up full. This is perhaps the rudest and

Fig. 1.

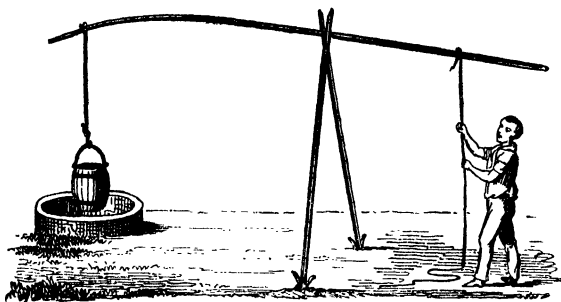

most inartificial of all contrivances for the elevation of the water. A pulley established over the mouth of the well is one degree more efficient.

The bucket being let down and dipped in the water, is drawn up by pulling the rope.

In this case the labour is expended not only in raising the weight of the water and of the bucket which contains it, but also that of the rope, which, if the well be deep, is not inconsiderable. Besides this a certain force must be exerted to bend the rope continually over the groove of the pulley, and to overcome the friction of the pulley itself in moving upon its axle.

3. A windlass established over the mouth of the well (fig. 2) is one degree, and only one degree, more efficient than these rude

## RAISING WATER.

expedients. In this case the bucket is raised by turning the winch of the windlass, so that the rope is gradually wound upon its axle. The power has still to raise the weight of the rope, to produce its flexure on the axle, and to overcome the friction of the axle of the windlass in its bearings.

In the contrivance of mechanical agents, the first object is always to remove as much as possible all

sources by which the moving power is absorbed upon useless objects. In the present case the only useful exertion of the moving force is that which is engaged in raising the water. The useless parts of the force expended, are, *first*, that absorbed by the weight of the bucket; *secondly*, that absorbed by the weight of the rope; *thirdly*, that absorbed in bending the rope over the groove of the pulley, or the curvature of the axle; *fourthly*, that which is expended on the friction of the axle in its bearings; *fifthly*, that which is expended in drawing the bucket aside when it has been elevated, and discharging the water from it into the vessel or reservoir destined to receive it; and, *sixthly*, that which is expended in letting down the bucket into the well to be refilled.

Now when all these sources of waste of power are considered, and estimated, and their aggregate amount determined, it will be apparent that they greatly exceed the force expended upon the mere elevation of the water.

4. A part of the loss of power arising from these causes is sometimes removed by the simple expedient of attaching two buckets to the extremities of the rope which passes over the pulley (fig. 3) established above the well. By these means, while the full bucket is drawn up the empty one descends, and by its weight and that of the rope which descends with it, the weight of the full bucket and the rope which ascends with it is balanced, so that the power has only to act against the weight of the water, the friction and the resistance to flexure presented by the rope.

Fig. 2.

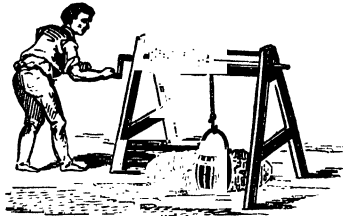
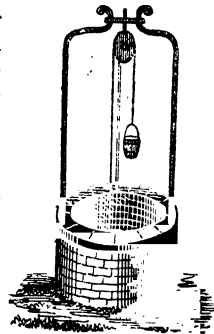

Fig. 3.



## COMMON THINGS—PUMPS.

5. Animal power may be applied to this method of raising water by such an arrangement as is represented in fig. 4. This is

Fig. 4.

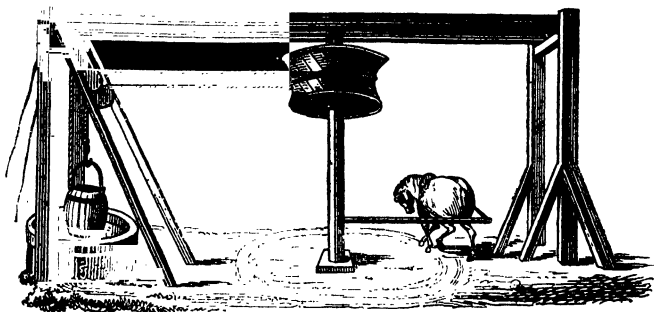

the method generally used in France by the market gardeners, in the environs of large towns, to raise water for irrigation. Two pulleys are established side by side, over the well, at such a distance asunder that two buckets or barrels suspended from them may pass each other as one ascends and the other descends, without mutual collision or obstruction. The rope supporting one bucket, after passing over one of these pulleys, is carried two or three times round a large vertical drum erected near the well, and then passing over the other pulley is let down into the well with the other bucket attached to it.

The semicircular handles to which the rope is attached, are connected with the barrels, not at the edge of the mouth, but at two points in their sides, a little above their middle point, so that when filled they will maintain themselves steadily in the vertical position, but when empty they will easily be turned upon their sides by mere contact with the surface of the water so as to fill themselves, when let down empty.

A horse or ox yoked to a lever of considerable length, projecting from the vertical shaft, turns it, and with it the drum, and continues to go round in the same direction, until one barrel is raised to the mouth of the well and the other is plunged in the water below and filled, the contents of this barrel being discharged into a reservoir or vessel destined to receive it. The animal is then yoked in the other direction, and again travels round until the other barrel is raised, and that which was just discharged let down.

6. It is evident that in this and all similar arrangements the weight of the rope on the whole balances itself; for although it preponderates against the power when the full barrel begins to

## LIFTING PUMP.

ascend, the ascending part of the rope being then longer than the descending, this preponderance gradually decreases until the ascending meets the descending barrel. At this point, the ascending and descending parts of the rope being equal, balance each other, and after this the descending part, preponderating, aids the power just as much as the ascending part previously opposed it. There is, therefore, so far as relates to the weight of the rope, a perfect compensation.

The same apparatus is much used in France, in raising stone through vertical shafts from subterranean quarries, and other mining operations.

7. If, instead of a rope and bucket, a pipe or tube be let down into the well, and in this pipe a piston be provided, having a valve in it opening upwards, this piston being worked in the usual manner upwards and downwards, the water would be lifted in the pipe. Such an apparatus is called a lifting-pump, and is represented in fig. 5: *w* is the water, *c d* the piston, *u* the valve in it which opens upwards. When the piston is moved downwards, this valve opens, and the water passes through it. When the piston is moved upwards, the column of water is pushed up, and the valve is kept closed by the pressure of the water upon it. A valve *x* is placed at *c d* in a fixed position, through which the column of water passes when the piston rises, and which prevents the return of such water downwards, the valve being kept closed by the weight of the water above it. The column of water driven upwards by the piston is pushed to any required height, through the pipe *E F*. In such an apparatus, the moving power must be equal to the weight of the water raised, together with the weight of the pump-rod and frame by which the piston is worked, as well as the friction of the moving parts.

Fig. 5.

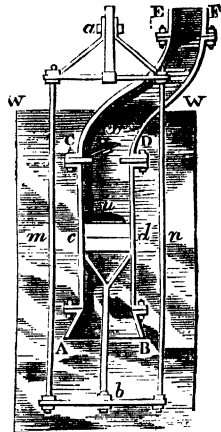

8. A very ingenious form of pump which, though differing altogether in appearance from the lifting pump, acts nevertheless upon precisely the same principle, is shown in fig. 6. It has the advantage of being nearly free from friction, and of being capable of being worked by the weight of an animal walking up an inclined plane, which is the most advantageous manner in which animal power can be applied.



## COMMON THINGS—PUMPS.

Let  $DC$  be a wooden tube of any shape, round or square, which descends to a depth in the well or reservoir equal to the height above the surface of the reservoir to which the water is required to be raised. Thus if  $DO$  be the height to which the water is to be raised above the level of the well, then the depth  $OC$  must be at least equal to  $DO$ .  $LM$  is a heavy beam or plunger, suspended from a chain, and capable of descending by its own weight in water, and passing water-tight through the collar  $FE$ . A valve,  $v$ , covers an opening placed at the bottom of the tube. By the hydrostatic pressure the water will enter the valve  $v$ , and fill the barrel to the level  $OG$  of the water in the cistern.  $GI$  is a short tube proceeding from the side of the barrel, at the surface of the water, and communicating with the vertical tube  $EN$  by a valve  $I$ , which opens upwards.  $K$  is the spout of discharge. The plunger  $LM$  hangs loosely in the tube, so that it moves upwards and downwards perfectly free from friction, except that of the collar  $FE$ , where it is properly lubricated. When this plunger is allowed to descend by its weight into the water which fills the lower part of the tube, the valve  $v$  is closed, and the water displaced by the plunger is forced through the valve  $I$  into the tube  $EN$ . When the plunger is raised the valve  $I$  is closed, and the water thus forced into the tube  $EN$  cannot return. The water from the

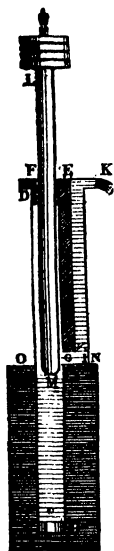

cistern then flows through the valve  $v$ , and rises in the tube to the level  $G$ . The next descent of the piston propels more water into the tube  $EN$ , and this is continued so long as the piston is worked.

The manner in which such an apparatus is worked by the weight of a man, or any animal, is represented in fig. 7, p. 183. Two pumps are used, such as that just described, and when the plunger descends in one it rises in the other. The two pumps communicate with one vertical pipe, which therefore receives a continual supply of water; for while the action of one pump is suspended the other is in progress. A man walks from one end of an inclined plane to the other, and by his weight upon one side or the other of the fulcrum causes the plungers alternately to rise and fall.

9. Valves are of such constant use in all forms of pump, that it will be useful here briefly to explain their principal varieties.

A valve in general is a contrivance by which water or other fluid flowing through a tube or aperture is allowed free passage in one direction, but is stopped in the other. Its structure is such, that while the pressure of the fluid on one side has a

## VALVES.

tendency to close it, the pressure on the other side has a tendency to open it.

As in all forms of pump the water is required to be moved upwards, all the valves necessarily open upwards and close downwards.

Fig. 7.

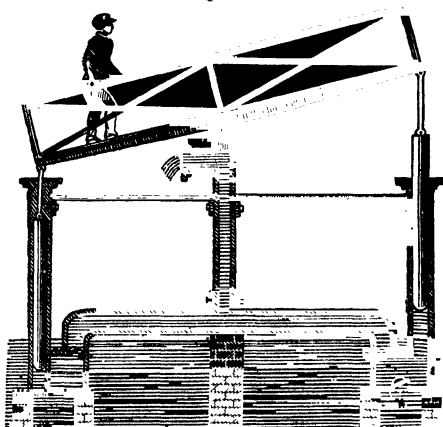

There are several varieties of form.

10. The clack valve is like the lid of a box (fig. 8). It opens upwards, playing upon a hinge, and when the water presses it downwards it is closed.

Fig. 8.



The single clack valve is the most simple example of the class. It is usually constructed by attaching to a plate of metal larger than the aperture which the valve is intended to stop, a piece of leather, and to the under side of this leather another piece of metal smaller than the aperture. The leather extending on one side beyond the larger metallic plate, and being flexible, forms the hinge on which the valve plays. Such a valve is usually closed by its own weight, and opened by the pressure of the fluid which passes through it. It is also held closed more firmly by the pressure of the fluid whose return it is intended to obstruct.

The extent to which such a valve should be capable of opening, ought to be such that the aperture produced by it shall be equal to the aperture which it stops. This will be effected if the angle through which it rises be about  $30^\circ$ .

Fig. 9.

A double clack consists of two semicircular plates, having the hinges on the diameters of the semicircles, as represented in fig. 9.



## COMMON THINGS—PUMPS.

Of the valves which are opened by a motion perpendicular to their seat, the most simple is a flat metallic plate, made larger than the orifice which it is intended to stop, and ground so as to rest in water-tight contact with the surface surrounding the aperture. Such a valve is usually guided in its perpendicular motion by a spindle passing through its centre, and sliding in holes made in cross bars extending above and below the seat of the valve.

11. The conical valves, usually called spindle-valves (fig. 10), are the most common of this class. The best angle to be given to the conical seat is found in practice to be  $45^\circ$ . With a less inclination the valve has a tendency to be fastened in its seat, and a greater inclination would cause the top of the valve to occupy unnecessary space in the valve-box. The area, or transverse section of the valve-box, should be rather more than double the magnitude of the upper surface of the valve, and the play of the valve should be such as to allow it to rise from its seat to a height not less than one-fourth of the diameter of its upper surface.

Fig. 10.



12. The valves coming under this class are sometimes formed as spheres or hemispheres (fig. 11) resting in a conical seat, and in such cases they are generally closed by their own weight, and opened by the pressure of the fluid which passes through them.

Fig. 11.

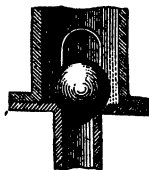

The several expedients already described however, greatly surpassed in convenience by the form of pump almost universally used in domestic and general economy, and known as the sucking or suction pump.

A section of this useful apparatus is shown in fig. 12, p. 169. It consists of a pipe or barrel, *s o*, which descends into the well, and the length of which must not exceed 32 feet. Attached to the top of this pipe, which is called the suction-pipe, is a large syringe, acting precisely on the principle of a common exhausting syringe.

At the commencement of the operation, the pipe *s e* is filled with air to the level of the water in the well. The operation of the syringe draws the chief part of the air out of this pipe *s e*. When the water within the pipe is partially relieved from the atmospheric pressure, the weight of the atmosphere, acting upon the external surface of the water in the well, forces it up in the pipe *s e*; and according as the air is withdrawn by the syringe, the water continues to rise, until it passes through the valve *x*. This valve

## SUCTION PUMP.

opening upwards, prevents its return, since the weight of the column above it will keep it closed. When the barrel A C becomes filled with water, the syringe no longer acts as such, but works on the principle of the lifting pump, already explained. When the piston descends, the valve *x* is closed and the valve *v* opened, the water passing through the piston. When the piston is raised, the valve *v* is closed, and the column of water above the piston is projected upwards.

Meanwhile the pressure of the atmosphere on the water in the well causes more water to rise in the pump-barrel following the piston.

The atmospheric pressure is capable of supporting a column of about 34 feet of water.\* It is evident, therefore, that such a pump as is here described can only be efficient when the piston is at a height of less than 34 feet above the surface of the water in the well, since otherwise the atmospheric pressure would not keep the water in contact with the piston.

The suction-pump, therefore, as compared with the lifting-pump, saves 34 feet length of pump rod; but otherwise there is no comparative mechanical advantage.

It might appear at first view that the pressure of the atmosphere sustaining a column of water in the suction-pipe, supplies aid to the power that works the pump, and spares an equivalent amount of that power.

This, however, is not the case, as will appear from a due consideration of all the forces which are in operation.

14. Of these forces there are some which are directed downwards from the top of the column raised by the piston towards the bottom of the well, and others which are directed upwards. Now it is evident that the mechanical power applied to draw the piston up will have to overcome all that excess by which the forces downwards exceed the forces upwards. Let us suppose a column of water resting on the piston, after having passed through the valve *v*. The upper surface of this column is pressed upon by the weight of the atmosphere; the piston has, therefore, this

Fig. 12.

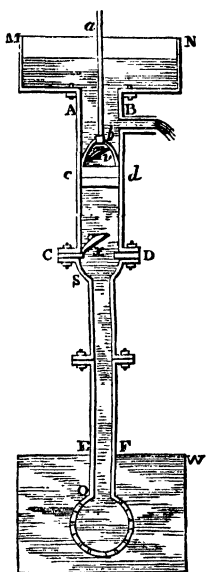

\* See Tract on Barometer (10).

## COMMON THINGS—PUMPS.

weight to sustain. It has also to sustain the weight of the water which is above it. The atmospheric pressure acting also on the water in the well, is transmitted by the water to the bottom of the piston; but this effect is diminished by the weight of the column of water between the surface of the water in the well and the bottom of the piston, for the atmospheric pressure must, in the first place, sustain that column, and can only act upon the bottom of the piston in the upward direction with that amount of force by which it exceeds the weight of the column of water between the piston and the well. The effect, therefore, on the piston is the same as if it were pressed downwards by the weight of the column of water between the piston and the well, and at the same time pressed upwards by the atmospheric pressure. Thus the piston may, in fact, be regarded as being urged downwards by the following forces,—the atmospheric pressure, the weight of the water above the piston, and the weight of the water between the piston and the well; that is to say, in fact, by the atmospheric pressure, together with the weight of all the water which has been raised from the well. At the same time, it is pressed upwards by the atmospheric pressure transmitted from the surface of the water in the well. This upward pressure will destroy the effect of the same atmospheric pressure acting downwards on the surface of the water above the piston, and the effective downward force will be the weight of all the water which is contained in the pump.

By this reasoning, it appears that the pump must be worked with as much force as is equal to the weight of all the water which is in it at any time, and, therefore, that the atmospheric pressure affords no aid to the working power.

Since the action of the pump in raising water is subject to intermission, the stream discharged from the spout will necessarily flow by fits and irregularly, if some means be not adopted to prevent this. At the top of the pump a cistern may be constructed, as shown in fig. 12, with a view to remove this inconvenience. If the pump be worked, in the first instance, so as to raise more water in a given time than is discharged at the spout, the column of water will necessarily accumulate in the barrel of the pump above the spout. The cistern *M N* will, therefore, be filled, and this will continue until the elevation of the surface of the water in the cistern above the spout will produce such a pressure, that the velocity of discharge from the spout will be equal to the velocity with which the water is raised by the piston. The level of the water in the cistern will therefore cease to rise. This level, however, will be subject to a small variation as the piston rises; for while the piston is descending, the water is flowing from the spout, and no water is raised by the piston, consequently the level of the water

## COMMON HOUSE PUMP.

in the cistern falls. When the piston rises, water is raised, and the quantity in the cistern is increased faster than it flows from the spout, consequently the level of the water in the cistern rises, and thus this level alternately rises and falls with the piston. But if the magnitude of the cistern be much greater than the section of the pump-barrel, then this variation in the surface will be proportionally small, for the quantity of water which fills a part of the barrel, equal to the play of the piston, will produce a very slight change in the surface of the water in the cistern. The flow, therefore, from the spout will be uniform, or nearly so.

The action of this sort of pump will be rendered still more easily intelligible by fig. 13, which represents the working model of a

Fig. 13.

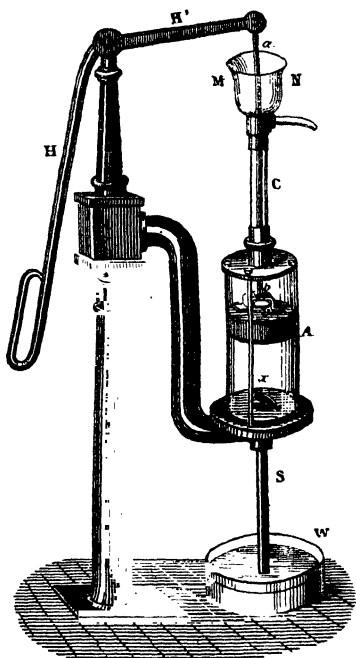

suction-pump usually provided for demonstrations in popular lectures. The pump-handle, *H H'* raises and lowers the piston rod *a*. The pump-barrel is formed of glass, so as to show the

## COMMON THINGS—PUMPS.

piston within it, having a valve opening upwards. The other parts of the apparatus are marked with letters corresponding with those of fig. 12.

15. Another form of pump, called the forcing-pump, is attended with many advantages, and is extensively used. This instrument is represented in fig. 14. The suction-pipe *c E* is similar to the suction-pump. The piston *c d* is a solid plug without a valve.

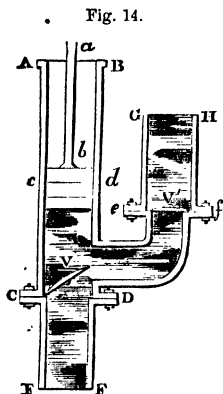

The forcing-pipe *G H* has at its base *e f* a valve *v'* which opens upwards. When the piston *c d* is raised, the valve *v* is opened, and the water rises from the suction-pipe into the pump-barrel. When the piston *c d* is pressed downwards, the valve *v* is closed, and the water is forced by the pressure of the piston through the valve *v'* into the force-pipe, and thus while the operation is continued, at each upward motion of the piston, water is drawn from the suction-pipe into the pump-barrel, and at each

downward motion it is forced from the pump-barrel into the force-pipe.

16. In order to produce a continued flow of water in the force-pipe, an air-vessel is often attached to force-pumps. Such an appendage is represented in fig. 15.

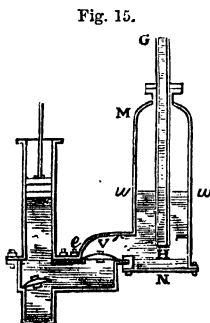

When the piston descends, the water is driven through the valve *v'* into the vessel which is closed and contains air. The force-pipe *G H* descends into this vessel, and terminates near the bottom. The water which is forced in rises in it to a certain level, *w w'*, the air above it being compressed. The return of the water through the valve *v'* being stopped, it is subject to the elastic pressure of the air confined in the air-vessel *M N*. This pressure forces the water through the tube *H G* from the top of which it issues in a constant stream.

The forcing-pump with its air-vessel, as constructed for demonstration at popular lectures, is shown in fig. 16, p. 189, where all the parts are indicated by the same letters as in figs. 14 and 15. The water which flows in a continual stream from the force-

## FORCING PUMP.

pipe *g* returns by the pipe *r* to the reservoir *R*, from which it is again raised by the pump.

Fig. 16.

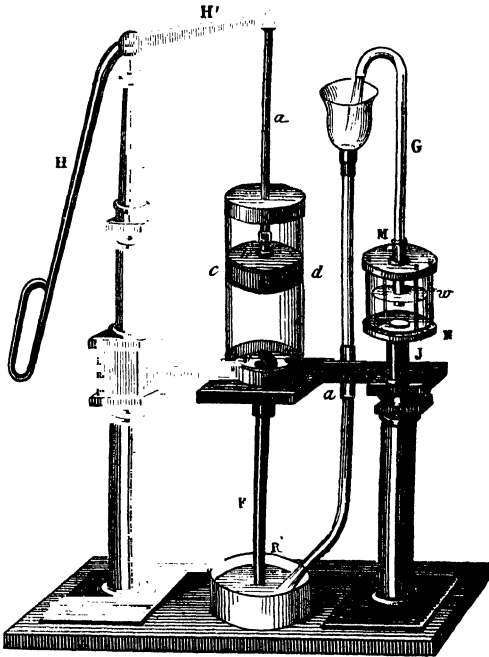

17. In the force-pump, where the water acts upon the piston with a great pressure, it is very important that the piston should move in complete water-tight contact with the pump-barrel. This is best accomplished by an accurately formed metallic plunger, *P*, fig. 17, working through a collar of leather, *A B*, which is exactly fitted to it, and with which it is made air-tight and water-tight, by being lubricated with oil or tallow. When this plunger is raised, the space it deserts is filled by the water which rises through the valve *v*, and when it descends, the water which filled the space into which it advances, is driven before it through the valve *v* into the force-pipe.

18. If the forcing-pump, represented in fig. 16, be attentively considered, it will be perceived that the principles on which the piston acts, in its ascent and descent, are perfectly distinct. In



## COMMON THINGS—PUMPS.

its ascent it is employed in drawing the water from the suction-pipe into the pump-barrel, and in its descent it is employed in forcing that water from the pump-barrel into the force-pipe.

Fig. 17.

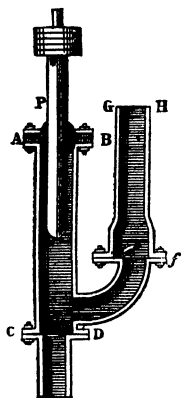

Now the piston being solid, and not furnished with any valve, there is no reason why its upper surface should not be employed in raising or propelling water as well as the lower. While the lower surface is employed in drawing water from the suction-pipe, the upper surface might be employed in propelling water into the force-pipe; and, on the other hand, in the descent of the piston, when the lower surface is employed in propelling water into the force-pipe, the upper surface might be engaged in drawing water from the suction-pipe. To accomplish this, it is only necessary that the top of the cylinder should be closed, and that the piston-rod should play through an air-tight collar, the top of

the cylinder communicating with the force-pipe and the suction-pipe, as well as the bottom.

Such an arrangement is represented in fig. 18. When the piston ascends, the suction-valve F is opened, and water is drawn

Fig. 18.

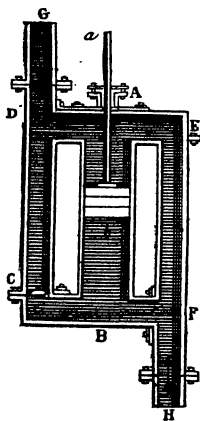

into the pump-barrel below the piston; and when the piston descends, the suction-valve F is closed, and the pressure of the piston on the water below it opens the valve c, and propels the water into the force-pipe c g. Also, while the piston is descending, water rises through the suction-valve E into the barrel above the piston; and when the piston ascends, the water being pressed upwards keeps the valve E closed, and opens the valve D, and is thus propelled into the force-pipe. By this arrangement the force-pipe receives a continual supply of water from the pump-barrel without any intermission; and in like manner the pump-barrel receives an unremitting flow from the suction-pipe. This will be distinctly seen, if it is considered that either of the two valves E

or F must always be open. If the piston go down E is open and F

## FIRE-ENGINE—CHAIN PUMP.

closed; if it go up *E* is closed and *F* open. A stream, therefore, continually flows through one valve or the other into the pump-barrel. In like manner, whether the piston ascend or descend, one of the valves, *c* or *D*, must be open.

19. The simple pumps used for watering gardens are shown in fig. 19, at the head of this tract, a single or double-action force-pump projecting a jet of water over the ground to be irrigated.

20. The fire-engine is a double forcing-pump, each barrel of which acts upon the principle explained above.

A section of such an engine, in its most usual form, is represented in fig. 20.

The solid pistons *a a* are alternately forced down upon the water which has been drawn into the barrels upon the principles already explained, and the water is thus forced into the air vessel *e*. The reaction of the compressed air drives the water with a proportionate force through the force-pipe *d* into a long, flexible, leathern hose, upon the end of which a large jet-pipe is screwed. The firemen carry this jet-pipe near to or into the building on fire, and with it throw up to great heights a constant stream of water, which, falling on the burning bodies, extinguishes the fire.

Fig. 20.

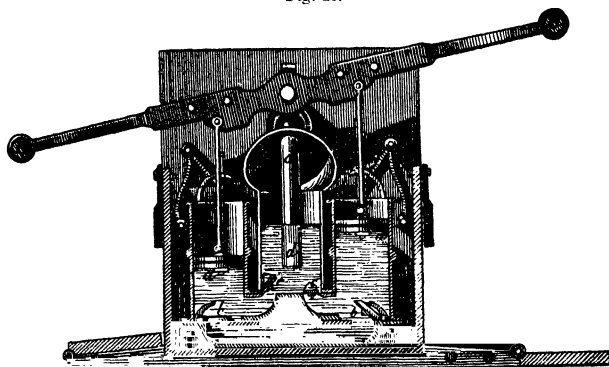

21. A form of lifting-pump, called the chain-pump, is commonly used to discharge the water from the hold of ships of war and other vessels of the large class. This pump consists of an endless chain which passes over two rollers, one of which is established on the deck, above the level at which the water is to be discharged, and the other at the bottom of the hold. Attached to the chain, and placed at right angles with it, are a series of saucers, or a sort

## COMMON THINGS—PUMPS.

of flat circular plates, one above the other, by which the water is lifted. These saucers lift the water and press it up through a vertical pipe placed near the ascending side of the chain. The water, rising through this pipe, is discharged into a cistern on the deck, from which it flows off into the sea through a waste pipe called the *pump-dale*.

There are two hollow vertical barrels, or cases, through one of which the chain ascends, and through the other it descends. The chain is worked by means of a winch attached to the upper roller, over which it passes. This winch receives a continual motion of rotation, by the power of men applied to its handles, which are so formed that several men can work them simultaneously.

In large vessels these pumps are constructed upon a scale sufficient to enable them to raise a ton of water, or about 250 gallons per minute.

22. The purpose to which pumps are applied on the most vast scale is in the drainage of mines. In that case the power required far exceeds the limit to which animal power is practically available, and even steam-power, by which such pumps are worked, requires to be applied on a scale far exceeding every other form in which it has been applied in the industrial arts.

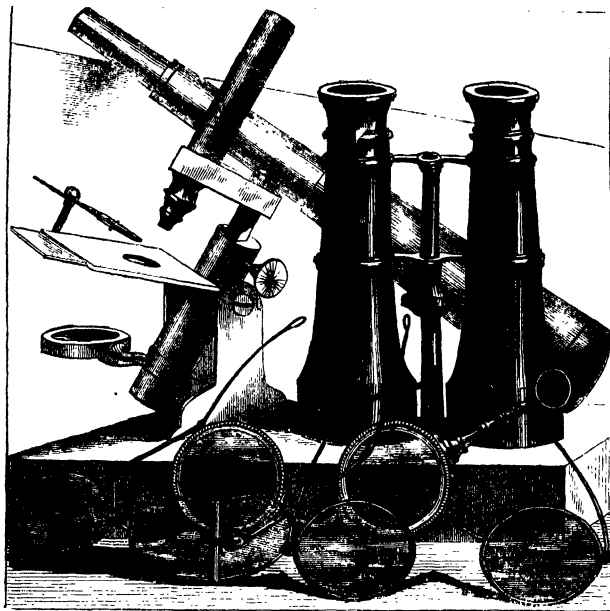

## COMMON THINGS.

### SPECTACLES.

1. Their general utility.—2. Should therefore be generally understood.—3. Vision.—4. Blindness.—5. Defective sight.—6. Long and short sight.—7. Remedy.—8. Spectacles.—9. Effect of convex lenses.—10. Of concave lenses.—11. Focal length of a lens.—12. Varies with distance of object.—13. Peculiarities of vision in short sight explained.—14. In long sight.—15. The mounting of spectacles.—16. Periscopic spectacles.—17. Both eyes have not always the same power of vision.—18. Ophthalmometer.—19. Application of it in selecting glasses.—20. Curious defects of vision.

1. SPECTACLES are incontestably the most universally useful gift which optical science has conferred on mankind. More wonderful instruments abound. The miracles disclosed to human vision by the telescope and the microscope are known to all. To such marvels, spectacles lay no claim. But to compensate for this

## COMMON THINGS—SPECTACLES.

their utility is ubiquitous. In the palace of the monarch and in the cottage of the peasant their beneficent influence is equally diffused. It is remarkable also, that, unlike most other productions of art and science, cost can add nothing to their perfection. Those of the millionaire may be mounted in gold, and those of the humble labourer in iron; but the optical medium, the glass lenses to which they owe their perfection, must be the same.

2. It is good that an object of such unbounded usefulness should be generally understood. The more completely and clearly the principles on which the application of the instrument depends are comprehended, the greater will be the extent of the benefit which each individual will derive from them, and the less frequent will be the inconveniences and evils resulting from their abuse.

Before it is possible, however, to comprehend the principle and the right use of spectacles, it is indispensably necessary to be acquainted with the structure and functions of the eyes, and such readers as have not already obtained that preliminary knowledge are referred for it to our tract on that subject.

The defects incidental to the sense of sight have been briefly noticed in that tract, and the optical expedients by which remedies have been obtained for them have been stated. We propose here to resume that subject, and to present other and more developed illustrations of it.

3. When an object is placed at a certain distance from the eye, a small picture or image, as it is called, of the object is produced upon the posterior surface of the coating which lines the inside of the spherical shell, called the eye-ball. This coating, upon which the picture is thus formed, is called the retina.

It is this picture on the retina which enables us to see the object. If this picture be obscure, falsely coloured, confused, or indistinct, our vision of the object will also be obscure, falsely coloured, confused, or indistinct.

In its natural and healthy state the structure of the eye is such that the pictures of all objects presented to it thus formed upon the retina, are clear, rightly coloured, and perfectly distinct in form and outline. In individual cases, however, eyes are variously defective.

4. If the coats and humours, through which the rays of light, proceeding from external objects ought to pass, be not in any degree transparent, no picture whatever is formed on the retina, and the subject is blind.

5. If the coats and humours are imperfectly transparent the picture will be obscure, being formed only by the rays of light partially transmitted through the humours.

## SHORT SIGHT—WEAK SIGHT.

It sometimes happens that the humours, like coloured glass or coloured liquids, transmit only light of a particular colour. In that case the image on the retina is falsely coloured, the false colours depending on the colour of the humours.

For these several classes of defects spectacles are wholly inefficacious.

6. When the humours are perfectly transparent and free from colour, the picture which they would produce may fall not immediately upon the retina, but at a distance more or less considerable before or behind it. In that case the effect produced upon the retina will be a picture more or less confused and indistinct. It will be so much the more indistinct as the place where the distinct picture would be formed is more distant from the retina.

If the place of the distinct picture be before the retina, the defect is owing to the eye having too great refracting power upon the rays of light. If it be behind the retina, it is owing to the refracting power being too feeble.

The former is called SHORT SIGHT, and the latter LONG SIGHT, or WEAK SIGHT.

7. For these defects of vision, which are by far the most common, spectacles supply a perfect remedy.

They accomplish this by the effect they are capable of producing upon the place of the picture. If the eyes be weak-sighted, and consequently the picture is formed *behind* the retina, spectacles are applied which have the effect of bringing forward the picture to the retina. If they be short-sighted, so that the picture is formed *before* the retina, spectacles are applied which have the effect of throwing it back to the retina.

8. Spectacles consist of circular discs of glass called lenses, the surfaces of which are brought by grinding and polishing to a convex or concave form.

9. If a convex lens of this kind be placed before the eye, it will have the effect of bringing forward the picture formed within the eye. A concave lens, placed in the same manner, will have the contrary effect of throwing it backward.

It will be easy for any person to convince themselves that such glasses have the properties here described.

Let a convex disc of glass or lens,  $GG$ , fig. 1, be placed before a candle,  $c$ , and let a white paper screen be placed behind  $GG$ , and moved towards and from it until a position is found, such as  $SS$ , in which a distinct inverted picture of the candle will be seen upon it. If the screen be now moved to  $S'S'$ , a little nearer to  $GG$ , so that the place of the distinct picture shall be *behind* it, an indistinct picture of the candle will be seen upon the screen.

In this case the lens  $GG$  may be imagined to represent the eye of

## COMMON THINGS—SPECTACLES.

a weak-sighted person, the candle  $c$  a visible object, and the screen  $s's'$  the retina, upon which an indistinct image of the object

Fig. 1.

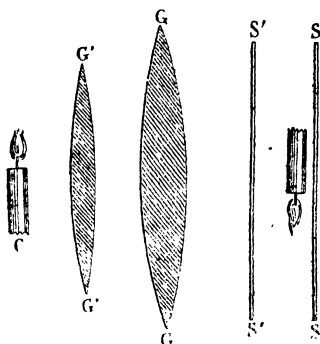

is depicted, and  $s s$  the place behind the retina, at which the picture would be distinct.

Now if another convex lens,  $G'G'$ , which may represent a spectacle glass, be placed before  $G G$ , it will have the effect of bringing forward the place of the distinct image, and it will bring that place more or less forward according as  $G'G'$  is more or less convex. It is easy to conceive that its convexity may be such that the image of the candle will be brought exactly to the position of the screen  $s's'$ .

Thus it appears, that if the screen be misplaced, with relation to the distinct picture of the candle, so as to be before it, a glass  $G'G'$  of suitable convexity, placed before  $G G$ , will bring the distinct picture forward to the position of the screen, upon which it will then be seen.

This is a simple experiment which any one can try with a candle, a sheet of paper, and two spectacle glasses.

It perfectly represents the case of a weak-sighted person, and the benefit they derive from convex spectacle glasses.

If, however, the lens  $G'G'$  be too convex, the picture will be brought too much forward, and it will be formed not on the screen  $s's'$ , but before it, and will consequently be indistinct. If, on the contrary, the lens  $G'G'$  be not sufficiently convex, the picture will not be brought so forward as the screen  $s's'$ , and will still be indistinct upon it.

Thus, between the relative positions of the distinct picture of the candle, that of the screen  $s's'$ , and the convexity of the lens

## CONVEX AND CONCAVE GLASSES.

$g'g'$ , there is a certain relation, such that only one particular degree of convexity will bring the distinct picture upon the screen.

In the same manner, it follows that between the relative positions of the retina, of the distinct picture formed behind it, and the convexity of the spectacle glasses, there is a certain fixed relation, such that such glasses only as have a particular convexity will bring the distinct picture on the retina, and produce clear and distinct vision.

10. Let us suppose now that the screen is placed as at  $s's'$ , fig. 2, *behind* the position at which the distinct picture of the candle is formed. In this case it is required to throw the

Fig. 2.

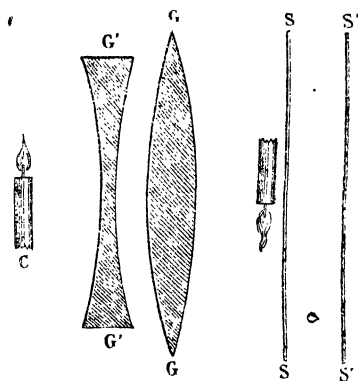

distinct picture *backwards*, and as it was brought forwards by the interposition of a *convex* glass, it will be thrown *backwards* by the interposition of a *concave* glass. Such a lens,  $g'g'$ , having the proper degree of concavity, being therefore placed before  $g g$ , the distinct image will be seen upon the screen  $s's'$ .

As in the former case, there is a certain relation between the relative positions of the distinct picture of the candle, of the screen  $s's'$ , and the concavity of the lens  $g'g'$ , so that only one particular degree of concavity will throw back the distinct picture to the screen.

As in the former case, this experiment illustrates the case of a short-sighted eye, and the remedy affixed by the interposition of a concave glass. The lens  $g g$  represents the eye,  $s's'$ , the retina, and  $s s$  the place before it where the distinct picture is formed



## COMMON THINGS—SPECTACLES.

when no glass is used. When  $g' g'$  is interposed between the object and the eye, the distinct image is thrown back to  $s' s'$ , the place of the retina.

11. The place at which the distinct image of a distant object is formed by a lens, or by any other optical medium equivalent to a lens, is called the FOCUS of the lens, and the distance of the focus from the lens is called the FOCAL LENGTH of the lens.

When the structure of the eye is perfect, therefore, its focus must be on the retina, and its focal length will be the interior diameter of the eye-ball. When the focal length of the eye is greater than this the focus is behind the retina, and the eye is weak-sighted or long-sighted. When the focal length is less, the focus is before the retina, and the eye is short-sighted.

12. If an object, a candle for example, placed before a convex lens, be moved towards the lens, the place at which its distinct picture is formed, that is its focus, will move from the lens, so that the nearer the object is to the lens the further will its picture be from it. It is easy to verify this by means of the candle, the lens, and the screen. As the candle is moved nearer and nearer to the lens, the place at which the screen will receive a distinct picture of the flame will be farther and farther from the lens, and in the same manner if the candle, being placed very near the lens, be gradually removed farther and farther from it, the place at which the screen will receive a distinct picture will be nearer and nearer to the lens.

This will explain some circumstances attending the vision of near-sighted and weak-sighted persons, which are familiar to every one.

13. When a near-sighted person looks at a distant object, its focus is within the eye-ball, before the retina, on which, consequently, the picture is indistinct. But if the object be brought gradually nearer and nearer to the eye, its distinct picture will move more and more backward, according to what has been just shown, and it will consequently approach nearer and nearer to the retina, until at length the object is brought so near the eye, that the distinct picture exactly falls upon the retina. The vision is then perfect.

It will thus be understood why near-sighted persons can see objects distinctly, only when they are brought within a certain distance of the eye. The more removed the focus of their eye is from the posterior part, the nearer an object must be brought before the picture is thrown back to the retina, and the person is said to be so much the more near-sighted.

Concave spectacle-glasses, in this case, have the same effect in throwing back the picture as the proximity of the object, and with

## EFFECTS OF SHORT AND LONG SIGHT.

such spectacles the object can consequently be seen distinctly without being brought near to the eyes. If, when the spectacles are interposed, the object be brought as near the eyes as would be necessary for distinct vision without spectacles, the vision will be indistinct; because, in that case, the effect of the glasses will be to throw the distinct picture behind the retina, which, without the glasses, would have been upon it.

When persons are not very short-sighted, they generally read or work without spectacles, but require their aid when they walk abroad or move in society in large rooms, because the book or the objects of their work can, without inconvenience, be placed at the moderate distance from their eyes which is sufficient to throw the focus back upon the retina, but the more distant objects at which they look when walking abroad or in large rooms are beyond the proper limit of distance, and the focus, being before the retina, must be thrown back by concave spectacles.

14. When an object is placed near the eyes of a weak-sighted person, the focus is behind the retina, and the picture on the retina is consequently indistinct. If the object be gradually removed to a greater and greater distance, the focus, according to what has been explained, will approach the retina nearer and nearer, and, if the sight be not too weak, it will come upon the retina when the object is removed to a certain distance from the eye. In this case, however, owing to the greater distance of the object, stronger illumination is required, and it is found, accordingly, that when weak-sighted persons hold a book at arms-length from the eyes, they are obliged, at the same time, to place a strong light near the page.

Eyes, which are not of very weak sight, have sufficient power to bring the picture of all objects, whose distance exceeds three or four feet, upon the retina. But for nearer objects, the picture, being behind the retina, requires to be brought forward by the interposition of convex spectacles. The nearer the object looked at is, the more convex ought the glasses to be, and hence it comes that very weak-sighted persons require to be provided with more than one pair of spectacles, those adapted to more distant objects being less convex, and those adapted to nearer objects more so.

When the weakness of sight is so limited that the pictures of distant objects fall upon the retina, those only of nearer ones being behind it, the eye is said to be FAR-SIGHTED, in contradistinction to the opposite defect, by which distinct vision is only obtained by the closer proximity of the object.

15. Spectacles consist of two glass lenses mounted in a frame so as to be conveniently supported before the eyes, and to remedy the defects of vision of naturally imperfect eyes.

## COMMON THINGS—SPECTACLES.

Whatever be the defects of sight which they may be used to remove, it is evident that the lenses ought to be so mounted that their axes shall be parallel, and that their centres shall coincide with the centres of the pupils when the optical axes are directed perpendicular to the general plane of the face, that is to say, when the eyes look straight forward.

These conditions, though important, are rarely attended to in the choice of spectacles. If spectacles be mounted in extremely light and flexible frames, the lenses almost invariably lose their parallelism, and their axes not only cease to be parallel, but are frequently in different planes. Spectacles ought therefore to be constructed with mounting sufficiently strong to prevent this derangement of the axes of the lenses, and in their original construction care should be taken that the axes of the lenses be truly parallel.

In the adaptation of spectacles it is necessary that the distance between the centres of the lenses should be precisely equal to the distance between the centres of the pupils. The clearest vision being obtained by looking through the centres of the lenses, the eyes have a constant tendency to look in that direction. Now if the distance between the centres of the lenses be greater than the distance between the centres of the pupils, the eyes having a tendency to look through the centres of the lenses, their axes will cease to be parallel, and will diverge as in the case of an outsquint. On the other hand, if the distance between the centres of the lenses be less than the distance between the centres of the pupils, there will, for a like reason, be a tendency to produce an insquint.

I have myself known persons of defective sight, who had never been able to suit themselves with spectacles, and concluded that they had some defect which spectacles could not remedy. Upon observing the form of their heads, I found, in each case, that the eyes were more distant asunder than eyes generally are, while the spectacles they used, being those made with the lenses at the usual distance, were never, and never could be, so placed as to be concentrical with the eyes, and hence arose the discomfort attending their use. In all such cases I removed the inconvenience by measuring the distance between the centres of the eyes, and causing proper glasses to be mounted in frames, so that the distance between their centres should correspond with the distance between the centres of the eyes.

I would therefore advise every one who uses spectacles to cause the distance between the centres of their eyes to be exactly measured, and to select for their spectacles mountings corresponding with this distance.

## PERISCOPIC SPECTACLES.

16. The most perfect vision with spectacles is produced when the eye looks in the direction of the axis of the lenses, and more or less imperfection always attends oblique vision through them. Persons who use spectacles, therefore, generally turn the head, when those whose sight does not require such aid merely turn the eye.

To diminish this inconvenience, the late Dr. Wollaston suggested the use of menisci, or concavo-convex lenses, instead of double concave or double convex lenses with equal radii, which up to that time had been invariably used.

Sections of lenses of this kind are given in figs. 3 and 4. In fig. 3, the convexity  $A' B' C'$ , of which the centre is  $o'$ , is greater than

Fig. 3.

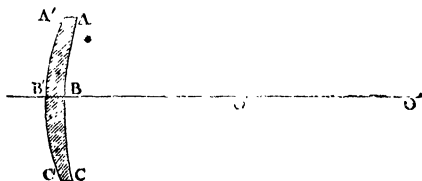

the concavity  $A B C$ , of which the centre is  $o$ , and the effect of the lens is the same as that of a convex lens. Such glasses are therefore adapted for weak sight. In fig. 4, on the contrary, the concavity  $A B C$ , of which the centre is  $o$ , is greater than the convexity

Fig. 4.

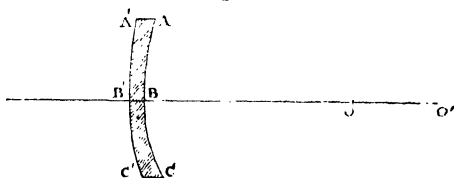

$A' B' C'$ , of which the centre is  $o'$ , and the effect of the lens is the same as that of a concave glass. Such glasses are therefore adapted to short sight.

The effect of these, as compared with double convex and double concave glasses, is, that objects seen obliquely through them are less distorted and, consequently, that there is a greater freedom of vision by turning the eye without turning the head, from which property they were named *periscopic spectacles*.

17. In the selection and adaptation of spectacles, it is invariably assumed without question, that the two eyes in the same indi-

## COMMON THINGS—SPECTACLES.

vidual have exactly the same refracting power. That this is the case is evident, from the fact that the lenses provided in the same spectacles have invariably the same focal length.

Now although it is generally true that the two eyes in the same individual have the same refractive power, it is not invariably so; and if it be not, it is evident that lenses of equal focal length cannot be at once adapted to both eyes.

When the difference of the refractive power of the two eyes is not great (which is generally the case when a difference exists at all), this inequality is not perceived. By an instinctive act of the mind, of which we are unconscious, the perception obtained by the more perfect of the two eyes in case of inequality is that to which our attention is directed, the impression on the more defective eye not being perceived.

It might be expected, however, that the inequality would become apparent, by looking alternately at the same object with each of the eyes, closing the other; but it is so difficult to compare the powers of vision of the two eyes when they are not very unequal, by objects contemplated at different times, even though they should be exhibited in immediate succession, that this method fails.

18. My attention having been directed to this question, I contrived an apparatus, which may not inaptly be called an *Ophthalmometer*, by which the least difference in the powers of vision of the two eyes may be rendered immediately apparent.

The principle I adopted for this purpose, resembles that which has been otherwise applied with success in photometers. I have so arranged the apparatus, that two similar objects similarly illuminated shall be at the same time visible in immediate juxtaposition, the one by the right eye being invisible to the left eye, and the other by the left eye being invisible to the right eye.

This apparatus consists of a small box,  $A B C D$ , fig. 5, about five inches in width,  $A D$ , ten inches in length,  $A B$ , and six inches in height. Within this there slides another box,  $A' B' C' D'$ , made nearly to fit it, but to move freely within it, the interior of this box being blackened, or lined with black velvet. In the end,  $B' C'$ , is a rectangular aperture, the length of which  $M N$  is about an inch, and the height about half an inch; the length, however, being capable of being augmented and diminished by slides. Opposite to the end of the box  $B C$  is a white screen, on which is traced a horizontal line parallel and opposite to the opening  $M N$ , and marked with a divided scale, the 0 of which is opposite to the centre of the aperture  $M N$ , and the divisions upon which are numbered in each direction from 0 by 1, 2, 3, 4, 5, 6. . . .

Let us suppose the eyes now applied at  $R$  and  $L$ . Let the

## EYES USUALLY UNEQUAL.

sliding interior box  $B' C'$  be moved until, on closing the left eye, the division 0 of the scale coincides with the edge  $M$  of the open-

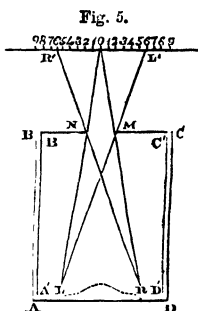

ing, and at the same time, by closing the right eye, the same division 0 of the scale coincides with the edge  $N$  of the opening. It will be always possible to make this adjustment, provided the eyes are placed centrally opposite the opening  $M N$ , which may be easily managed by cutting in the edge of the box  $A D$  an opening to receive the bridge of the nose. This arrangement being made, it is clear that if we close the left eye we shall see the space upon the scale included by the lines  $B N$  and  $B M$  continued to the screen  $R' I'$ . Let us suppose this space to include the six divisions of the scale from 0 to 6. If we close the right eye, we shall see with the left eye the six divisions of the scale to the right of 0. Now if we open both eyes and look steadily with them through the aperture  $M N$ , giving no more attention to the impression on the one than on the other, we shall see the twelve divisions of the scale, six to the right and six to the left of 0; the six divisions to the left of 0 being seen only with the right eye, and the six divisions to the right of 0 being seen only with the left eye.

In this way we have two similar objects, similarly illuminated and of equal magnitude, in immediate juxtaposition, the one seen by the right and the other by the left eye; and any difference in their distinctness, quality, brilliancy, or colour, will be as clearly and instantly perceivable as the comparative brilliancy of spaces illuminated by two different lights in the photometer. I have already experimented with this apparatus upon my own eyes, the result of which is, that I find that the sight of the right eye is much better than that of the left, the figures to the left of 0 being always more distinct than those to the right of it: but, what is more remarkable, I find that the transparency of the humours of

the right eye is more perfect than that of the humours of the left eye, for the space to the right of  $O$  always appears less bright than the space to the left of it.

19. To apply this instrument for the purpose of adapting spectacle lenses to eyes of unequal powers of vision, it is necessary first to ascertain the existence of the inequality of power in the manner already explained. It would then be necessary to provide two distinct screens on which similar scales might be drawn, so that they might be placed at different distances from the aperture  $M N$ . Let their relative distances be then determined, so that the two eyes would see the scales with equal distinctness. These distances will then represent the focal lengths of the divergent lenses which it would be necessary to provide for the eyes, so as to make them see different objects with equal distinctness.

In the case of weak-sighted eyes, this method will not be applicable. In that case let the two screens be placed at equal distances from the aperture  $M N$ , and let lenses be selected for each eye separately, closing the other, so as to give a distinct perception of the scales. The two lenses being then simultaneously applied to the eyes, let the scale be viewed with both eyes open. If the lenses be adapted to correct the defect of vision, the two parts of the scale to the right and to the left of  $O$ , seen at the same time by each eye alone, will appear of uniform brilliancy and distinctness.

If defective eyes were tested by this method, I believe it would be found that inequality of vision would be much more common than is generally supposed, and accordingly the adaptation of spectacles would be considerably improved.

20. Cases occur not only in which the comparative powers of vision of the two eyes differ, but in which the power of vision, even of the same eye, is different when estimated in different directions.

I have known short-sighted persons who were more short-sighted for objects taken in a vertical than in a horizontal direction. Thus with them the height of an object would be more perceptible than its breadth, and in general, vertical dimensions more clearly seen than horizontal. This difference arises from the refractive power of the eye taken in vertical planes being different from the refractive power taken in horizontal planes; and the defect is accordingly removed by the use of lenses whose curvatures, measured in their vertical direction, is different from their curvature measured in their horizontal direction. The lenses, in fact, instead of having *spherical* surfaces, have *elliptical* surfaces, the excentricities of which correspond with the variation of the refractive power of the eye.

## THE KALEIDOSCOPE.

- ♦—
1. Origin of the name.—2. Structure of the instrument.—3. Its optical effect.—4. Varieties of its form.—5. Its occasional use in the arts.—6. Another optical toy depending on two reflections.

1. THIS pretty optical toy, which is named from three Greek words, *καλον ειδος* (*Kalon eidos*), a beautiful form, and *σκοπεω* (*skopeo*) I see, depends upon the properties of the looking-glass.

2. Two oblong slips of looking-glass,  $A a c c$ , and  $A a b b$ , fig. 1, are placed edge to edge at  $A a$ , inclined to each other at an angle of  $60^\circ$ .

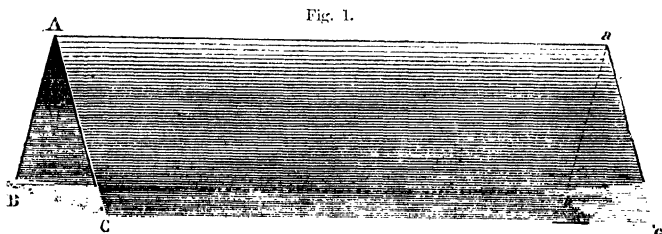

Thus placed, they are fixed in a tube of tin or brass of corresponding size, one end view of which is shown in fig. 2, where the circle  $A C B$  represents the tube, and  $A B$  and  $A C$  the edges of the plates of glass. One end of the tube is covered by two discs of glass, between which broken pieces of coloured glass or other transparent coloured object are placed loosely, so that they can fall from side to side, and take an infinite variety of casual arrangements. The external disc is ground-glass, to prevent the view of external objects disturbing the effect. The other end of the tube is covered by a diaphragm, with a small eye-hole in its centre, through which the observer looks at the coloured objects contained in the cell at the other end. He not only sees these objects, but also their reflection in each of the inclined glasses; and when the angle of inclination is  $60^\circ$ , the object will be seen five times repeated in positions regularly disposed round the line formed by the edges at which the glasses touch each other.

3. The angular space,  $B A C$ , included between the glasses, and every object within it, will be seen reflected in each glass. Thus  $B A C$  will be seen in the glass  $B A$ , as if it were repeated in the



## THE KALEIDOSCOPE.

space  $B A C'$ , and in the glass  $A C$ , as if it were repeated in the space  $C A C''$ . But this is not all. The reflection  $B A C'$  becomes an object before the glass  $A C$ , and being reflected by it, is reproduced in the space  $C'' A C'''$ , and the reflection  $C A C''$  being reflected by the glass  $A B$ , is reproduced in the space  $C' A C'''$ . Thus besides

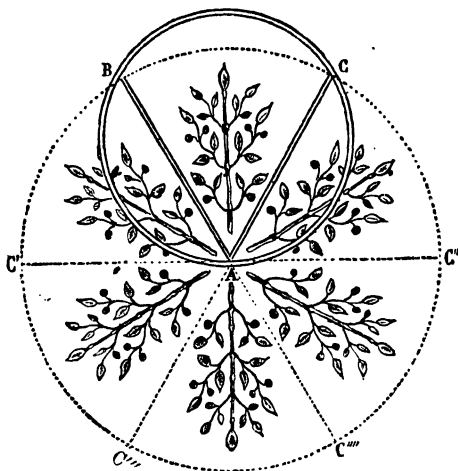

the view of the objects themselves which are between the glasses, and which would be seen if there were no reflection, the observer will see the four reflections, two  $C A C''$  and  $C'' A C'''$  to the right, and two  $B A C'$  and  $C' A C'''$  to the left.

But the reflection  $C' A C'''$  is again reflected by the glass  $A C$ , and is seen in the space  $C''' A C''''$ , and at the same time the reflection  $C'' A C'''$  is reflected in the glass  $A B$ , and is also reproduced in the same space  $C'' A C''''$ . Thus it appears that this space  $C'' A C''''$  receives the reflection of both glasses.

The observer looking through the eye-hole of the kaleidoscope sees a circle whose apparent diameter  $C C'''$  is twice  $A C$  the breadth of the reflector. This circle is divided into six angular spaces, two of which are the first reflections, and other two the second reflections of the inclined glasses. The other two consist of the actual space included between the glasses, and a similar space opposite to it which receives at once the third reflection of both glasses.

Since looking-glasses never reflect *all* the light incident upon

## THE KALEIDOSCOPE.

them, these reflections will not be as vivid as the direct view of the space  $bc$ ; nor will they, compared one with another, be equally vivid. The reflections  $bc'$  and  $c'c''$  will be less vivid than the object  $bc$ , but more so than the second reflections  $c'c'''$  and  $c''c'''$ . The third reflection  $c'''c''''$  would be less vivid than the second  $c'c'''$  and  $c''c'''$ , if it proceeded only from one glass as do the latter. But it must be remembered that being the combined reflection of both glasses, the loss of brightness by the multiplied reflections of each glass is to some extent compensated.

4. We have here supposed that the glasses are inclined at  $60^\circ$ , but they may be inclined at any angle which is an aliquot part of  $360^\circ$ . Thus if they are inclined at  $90^\circ$ , the circular space or field of view round  $A$  will be divided into four angular parts, and the same observations are applicable. If the glasses are inclined at an angle of  $45^\circ$ , the field of view will be divided into eight equal angular spaces, seven of which will be filled by the reflections.

From what has been here explained, the unequal brightness of the angular spaces seen in the kaleidoscope will be understood. If, as is most common, the angle of the glasses be  $60^\circ$ , this is perceptible, but if it be  $45^\circ$ , the repeated reflections so reduce the brightness as to impair the beauty of the effect.

5. The effects of the kaleidoscope are very striking, in consequence of the endless variety of which they are susceptible, even with a single cell at the object end of the instrument; but it may be so arranged that several cells, including different collections of coloured objects, may be provided, and may be changed one for another, fitting on the end of the tube like the cover of the object glass of a telescope.

The effects of this pretty little optical contrivance have been occasionally rendered useful in the industrial arts, in suggesting patterns for carpets and other products of the loom.

6. An amusing optical toy is represented in fig. 3, by means of

Fig. 3.

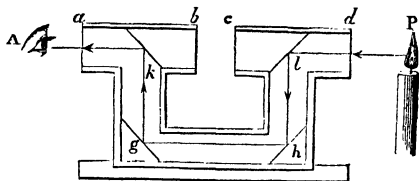

which objects may be seen, notwithstanding the interposition of any opaque screen between them and the eye. The rays proceeding from the object  $P$  entering the tube  $d$  strike on the mirror  $l$

## THE KALEIDOSCOPE.

placed at an angle of  $45^\circ$ , and are reflected downwards vertically to the mirror *h*, also placed at  $45^\circ$ , from which they are reflected horizontally to the mirror *g* placed at  $45^\circ$ , from which they are again reflected vertically to the mirror *k* placed at  $45^\circ$ , from which they are reflected horizontally to the eye at *A*. The eye thus sees the object after four reflections, the rays which render it visible having travelled round the rectangular tube *l h g k*.

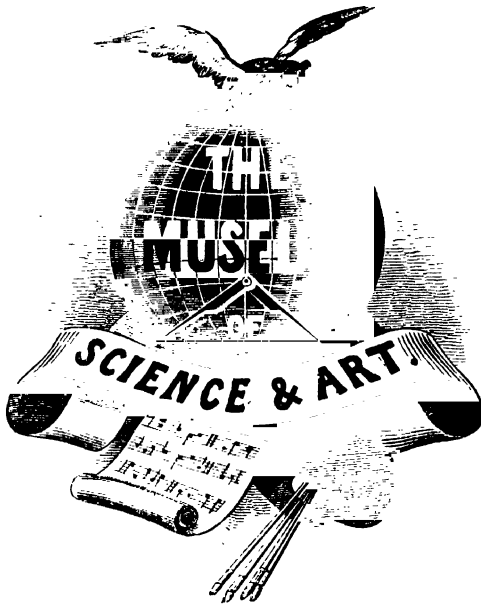

EDITED BY

DIONYSIUS LARDNER, D.C.L.,

Formerly Professor of Natural Philosophy and Astronomy in University College, London.

ILLUSTRATED BY ENGRAVINGS ON WOOD.

VOL. VI.

LONDON:

WALTON AND MABERLY,

UPPER GOWER STREET, AND IVY LANE, PATERNOSTER ROW.

1855.

LONDON  
BRADBURY AND EVANS, PRINTERS, WHITEFRIARS.

## CONTENTS.

### COMMON THINGS—CLOCKS AND WATCHES.

	PAGE
CHAP. I.—1. General want of time measurers.—2. No natural measures for short intervals.—3. Approximative expedient by shadows.—4. Sun-dials.—5. Differently constructed for, different places.—6. Earliest sun-dials.—7. Clepsydra, or water-clock.—8. Hour-glass.—9. Mercurial time-gauge.—10. Clocks—their chief parts.—11. Regulating power of the pendulum.—12. Uniform rate of vibration.—13. Analysis of a vibration.—14. Experimental verification of isochronism.—15. Moving power sustains the vibration.—16. Vibration not dependent on weight of pendulum.—17. Time of vibration varies with the length.—18. Analysis of motion of pendulous mass.—19. How the pendulum governs the hands.—20. Produces intermitting motion.—21. Pendulum's motion maintained by moving power . . . . .	17
CHAP. II.—22. Action of pendulum on escapement wheel.—23. Rate of motion of hands produced by tooth and pinion work.—24. Method of making pinions.—25. Mutual action of toothed wheels.—26. Wheel and pinion.—27. Bevelled and crown wheels.—28. Weight applied as a moving power.—29. Why hands not turned back when clock is wound up.—30. Mainspring.—31. Its power variable.—32. The fusee.—33. Balance-wheel.—34. Its vibrations uniform.—35. General explanation of a watch.—36. Of a clock moved by a weight.—37. Method of regulating the rate . . . . .	17
CHAP. III.—38. Method of regulating a balance-wheel.—39. Recoil escapement.—40. Cylindrical escapement.—41. Duplex.—42. Lever.—43. Detached.—44. Maintaining power of a clock moved by a weight.—45. Of a watch moved by a mainspring.—46. Weight of mainspring and pendulum and balance-wheel variously combined.—47. Watches and chronometers.—48. Marine chronometers.—49. Stationary chronometers.—50. Striking apparatus. . . . .	33

## MICROSCOPIC DRAWING AND ENGRAVING.

	PAGE
CHAP. I.—1. Beautiful precision of the minute structure of natural objects.—2. Cornea of a fly's eye.—3. Number of eyes of different insects.—4. Astonishing precision of artificial objects.—5. Demand for such objects by Microscopists.—6. Classes of such artificial objects.—7. Microscopic scales.—8. Method of engraving them.—9. Measurement of microscopic objects with them.—10. Their minuteness.—11. Scales of Mr. Froment.—12. Rectangular scales.—13. Micrometric threads.—14. Necessity for microscopic tests.—15. Test-objects.—16. Telescopic tests; double stars.—17. Nebulae and stellar-clusters.—18. Effects of different telescopes upon them: telescopes of Herschel and Lord Rosse.—19. Remarkable nebulae described by Herschel.—20. Differently seen by Lord Rosse.—21. Microscopic tests.—22. Improved powers of microscope.—23. The <i>Lepisma-Saccharina</i> .—24. The <i>Podura</i> , or Spring-tail . . . . .	49
CHAP. II.—25. Natural tests not invariable.—26. Natural tests imperfect standards.—27. Nobert's test-plates.—28. The degree of closeness of their lines.—29. Their use.—30. Apparent error respecting them.—31. Froment's microscopic engraving.—32. Method of executing it.—33. Various methods of microscopic drawing.—34. Drawings by squares.—35. Dr. Goring's drawings.—36. Structure and metamorphosis of insects.—37. The day-fly.—38. The larva of this insect.—39. Its organs of respiration.—40. Its general structure.—41. Its mobility.—42. State of chrysalis.—43. The perfect insect.—44. The production and deposition of its eggs, and its death.—45. Death may be delayed by postponing the laying of the eggs.—46. They take no food.—47. Their countless numbers; their bodies used as manure . . . . .	
CHAP. III.—48. The beetle.—49. Its larva.—50. Drawing of it in its natural size.—51. Dr. Goring's magnified drawing.—52. Production of the beetle from the egg.—53. The young larva.—54. Its voracity and manner of seizing its prey.—55. Description of its organs.—56. Its chrysalis.—57. Water-beetle.—58. Gnat.—59. Dr. Goring's method of drawing.—60. Drawing by the camera-lucida.—61. Section of the human skin; sweating-gland and duct.—62. The itch insect.—63. Method of obtaining it . . . . .	81
CHAP. IV.—64. Structure of the itch insect.—65. Its habits.—66. The mange insect.—67. Its form and structure.—68. Defects incidental to drawing with the camera.—69. Microscopic photographs.—70. Microscopic daguerreotypes by Messrs. Donné and Foucault.—71. Description of the blood.—72. Red and white corpuscles.—73. Daguerreotype of a drop of blood magnified.—74. Magnitude of the corpuscles.—75. Cause of the redness of	

	PAGE
blood.—76. Corpuscles of inferior animals.—77. White globules.	
—78. White grains.—79. White globules converted into red corpuscles.—80. Red corpuscles dissolved.—81. Circulation of the blood.—82. Method of showing it in the tongue of a frog.	
—83. The arteries distinguishable from the veins.—84. The vascular system of the tongue.—85. Mucous glands.—86. Milk; its constitution.—87. Magnified view of a drop of milk.—88. The butter globules.—89. Their number variable.—90. Analysis of the milk of different animals.—91. Richness of woman's milk.—92. Analogy of milk to blood.—93. Importance of the quality of milk.—94. Its richness ascertained.—95. Quévenne's hydrometer applied to milk.—96. Its fallacy.—97. Donne's lactoscope.—98. Objections to it answered.—99. Frauds practised by milk vendors.—100. Fore-milk and after-milk.—101. Self-engraved photographic pictures.	97

THE LOCOMOTIVE.

CHAP. I.—1. Familiar to every eye.—2. Its mechanism not generally understood.—3. Object of this Treatise.—4. Two modes of propelling wheel carriages.—5. How locomotive is propelled.—6. Action of piston-rod on wheels.—7. Dead points.—8. Unequal action.—9. How remedied.—10. Connection of piston-rods with wheels.—11. Wheels fixed on their axles.—12. Form of locomotive.—13. Driving-wheels.—14. Coupled wheels.—15. Consumption of steam.—16. Evaporating power of boiler determines efficacy of engine.—17. Fire-box.—18. Tubes through boiler.—19. Fuel.—20. Blast-pipe.—21. Tender.—22. Plans and sections, with their description	113
--	-----

CHAP. II.—23. Speed.—24. Locomotive stock.—25. What record of the performance and condition of an engine should be kept.—26. Cause of renewals of English locomotives.—27. Average mileage of engines.—28. Locomotive requires rest.—29. Expense of cleaning and lighting.—30. Reserve engines.—31. Bank engines.—32. Time they are kept standing.—33. Economy of fuel.—34. Register of consumption.—35. Small amount of useful service obtained.—36. On Belgian lines.—37. On other Continental lines.—38. On London and North Western line.—39. Comparisons between lines not fairly instituted.—40. Legitimate test of comparison.—41. Amount of locomotive stock required.—42. Gross receipts of European Railways in 1850.—43. Mileage of the same.—44. Great increase since.—45. Enormous consumption of coal.—46. Mileage of passengers and goods	129
--	-----



## THE THERMOMETER.

	PAGE
1. Heat.—2. Sensible heat.—3. Latent heat.—4. Contraction and dilatation.—5. Liquefaction and solidification.—6. Vaporisation and condensation.—7. Incandescence.—8. Combustion.—9. Temperature.—10. Conduction.—11. Radiation.—12. Some bodies are pervious to heat.—13. Some reflect heat.—14. Means of measuring the degrees of heat.—15. Mercurial thermometer.—16. Preparation of mercury.—17. Selection of tube.—18. Formation of bulb.—19. How the tube is filled.—20. Scale applied.—21. Graduation of scale.—22. Zero point.—23. Standard points.—24. Freezing and boiling temperatures universally adopted.—25. Fahrenheit's scale.—26. Centigrade.—27. Reaumur's.—28. Increase of volume of mercury.—29. Uniformity of its dilatation.—30. Standard thermometer.—31. Range of scale.—32. Why mercury is employed in thermometers.—33. Self-registering thermometers.—34. Alcohol thermometers.—35. Air thermometer.—36. Differential thermometer . . . . .	145

## THE NEW PLANETS.

1. Discovery of these planets.—2. The old planets.—3. Numerical law of their distances.—4. A missing planet.—5. Conjecture of Professor Bode.—6. Discovery of Ceres.—7. Of Pallas.—8. Theory of Dr. Olbers—a broken planet.—9. Discovery of Juno.—10. Of Vesta.—11. Rapid discovery of the others.—12. Table of the group.—13. Circumstances corroborating the theory of Dr. Olbers.—14. Amateur astronomers.—15. Minute bulk of these planets.—16. Corroboratory of Dr. Olbers' theory.—17. Force of gravity upon them . . . . .	161
---	-----

## LE VERRIER AND ADAMS' PLANET.

1. Surprise excited by the discovery.—2. How a body may be discovered without seeing it.—3. Generalisation of the principle.—4. Its application to the case of Neptune.—5. Condition of the solar system before the discovery.—6. Observed disturbances of Uranus.—7. Great regularity of these effects.—8. How they would be produced by a more distant planet.—9. Calculations of Le Verrier and Adams.—10. Elements of the sought planet according to these geometers.—11. Its actual discovery.—12. Its corrected elements.—13. Discrepancies between the actual and predicted elements explained.—14. Comparison of the effects of the real and predicted planets.—15. The discovery not to be ascribed to chance.—16. The period of Neptune computed.—17. Computation of his distance.—18. Its prodigious orbital motion.—19. Illustrated by a railway train.—20. Its magnitude.—21. Its satellite.—22. Its weight.—23. Its bulk.—24. The sun's light and heat upon it.—25. The sun's apparent diameter seen from it.—26. Its suspected ring . . . . .	171
--	-----

## MAGNITUDE AND MINUTENESS.

	PAGE
Relative magnitude.— 2. Manifestations of Divine wisdom.—	
3. Smallness of great mountains compared with the bulk of the earth.—4. Of the earth compared with Jupiter and Saturn.—	
5. With the Sun.—6. With other celestial objects.—7. Minute particles of which all bodies are composed.—8. Solid, liquid, and gaseous states—how produced.—9. Mechanical subdivision.—10. Pulverised marble.—11. Inequalities of polished surfaces.—12. Particles of gold on touchstone.—13. Filaments of glass.—14. Micrometer wires.—15. Gold leaf.—16. Gilt silver threads for embroidery.—17. Soap bubbles.—18. Insects' wings.—19. Filaments of wool, silk, and fur.—20. Red Particles in the blood.—21. Animalcules.—22. Spider's web.—23. Minute subdivision of a grain of salt.—24. Of sulphate of copper.—25. Of musk.—26. Of strychnine.—27. Of ammoniacal hypo-sulphite.—28. Of sugar.—29. Is matter infinitely divisible?—30. Crystallisation of salt.—31. Ultimate atoms.—32. Natural crystals.—33. Plane of cleavage.—34. Determinate figure of ultimate atoms.—35. Principles of mechanical science independent of this hypothesis.—36. Matter not destructible.—37. By combustion.—38. By evaporation.—39. By destructive distillation.—40. Nor by any other process . . . . .	198



Fig. 17.

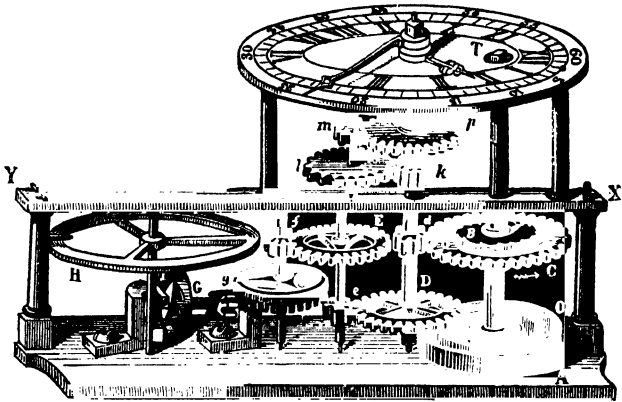

## COMMON THINGS.

### CLOCKS AND WATCHES.

#### CHAPTER I.

1. General want of time measurers.—2. No natural measures for short intervals.—3. Approximative expedient by shadows.—4. Sun-dials.—5. Differently constructed for different places.—6. Earliest sun-dials.—7. Clepsydra, or water-clock.—8. Hour-glass.—9. Mercurial time-gauge.—10. Clocks—their chief parts.—11. Regulating power of the pendulum.—12. Uniform rate of vibration.—13. Analysis of a vibration.—14. Experimental verification of isochronism.—15. Moving power sustains the vibration.—16. Vibration not dependent on weight of pendulum.—17. Time of vibration varies with the length.—18. Analysis of motion of pendulous mass.—19. How the pendulum governs the hands.—20. Produces intermitting motion.—21. Pendulum's motion maintained by moving power.

1. AFTER the supply of the absolute necessities of physical existence—food, clothing, and lodging—one of the first wants of a society, emerging from barbarism, is the means of measuring and registering time. In civilised society, all contracts for labour, and for all kinds of service, are based upon time. Even in the cases of the highest public functionaries, and where the service rendered is purely social and intellectual, still it is regulated, limited, and compensated with relation to time. Time measurers

## COMMON THINGS—CLOCKS AND WATCHES.

or chronometers were therefore among the earliest mechanical and physical inventions.

2. Although nature has supplied visible signs to measure and mark the larger chronometric units, such as days, months, and years, she has not furnished any corresponding measures of the lesser units of hours, minutes, and seconds. There are no visible marks on the firmament by passing from one to another of which the sun can note the hours, still less are there any signs for minutes or seconds. These subdivisions are therefore merely artificial and conventional, and to measure and mark them, artificial motions must be contrived.

3. Rough approximations were first made to the chief divisions of the day, by observing the apparent motion of the sun from rising to setting. Thus the direction of the meridian, or of the south, being once known, and marked by some fixed and visible object, the time of noon was known by observing when the sun had this direction. The hours before and after noon were roughly estimated by the position of the sun between noon and the times of its rising and setting. Greater precision was given to this method, by erecting a wand or gnomon, the shadow of which would fall upon a level surface, in a direction always opposite to that of the sun. Thus, after sunrise, the shadow would be inclined towards the west, the sun being then towards the east. From the moment of sunrise until noon, the shadow would move continually nearer and nearer to the direction of the north, and at noon it would have exactly that direction. From noon to sunset the shadow would be more and more inclined towards the east.

It is evident, however, that such a dial would not afford uniform indications at all seasons of the year, so that the hour-lines of the shadow determined in spring, for example, would not show the same hours in winter as in summer. Without much astronomical knowledge, it is easy to be convinced of this. At the equinoxes, the sun rises and sets at six o'clock, and at the east and west points precisely; and, therefore, at these seasons, the six o'clock hour-lines of such a dial would be for the morning due west, and for the evening due east. But on the first day of summer (21st June), the sun rises and sets at points of the horizon very much north of the east and west points, and at six o'clock in the forenoon and afternoon its bearing is north of the east and west points.

4. A dial so constructed at any given place would be useless as a time indicator. To render it useful, it would be necessary that the shadow of the style should fall in the same directions at the same hours at all seasons of the year. Now, to attain this object, the style must be not vertical, but must be directed to the celestial pole. It is easy to comprehend that in that case a plane

## SUN-DIALS.

passing through the style and the sun would always be carried round the style with an uniform motion by the diurnal motion of the sun, and that at all seasons this plane would at the same hours have the same position.

It is for this reason that the gnomon of sun-dials is placed at such an inclination with the plate of the dial, that when the dial is properly set the gnomon will be directed to the north pole of the heavens, and being so placed, its shadow will fall upon the same lines of the dial at the same hours, whatever be the season of the year.

5. It is evident, therefore, that dials must be differently constructed for places which have different latitudes. We have shown in a former Tract\* that the elevation of the celestial pole is equal to the latitude of the place, and consequently the inclination of the gnomon of a sun-dial must be also equal to the latitude of the place where the dial is intended to be set. It follows, therefore, that a dial constructed for London would not be suitable for York, Newcastle, or Edinburgh.

The position of the plate of the dial upon which the shadow of the gnomon is projected is quite unimportant. All that is really important is the direction of the gnomon, which must always be that of the celestial pole, whatever be the position of the plate of the dial. Thus the plate of the dial may be either horizontal, vertical, or oblique. Its position will depend upon the place where it is to be erected. If it be in an open space, as in a garden or field, having a clear exposure on all sides, it will be generally most convenient to make it horizontal; and, hence, in such cases, it is usual to fix it upon the top of a column of three or four feet high, so that it may be easily observed by a person of ordinary height standing near it. Sometimes it is convenient to place it upon the wall of a building, such as a church. A wall with a southern exposure is in that case the most convenient; but to indicate the hours of the early morning in the spring and summer, an eastern exposure would be required, and to indicate those of the late evening a western exposure would be necessary.

Where these vertical dials are erected, it is therefore frequently the practice to establish them at the same time on different walls of the same building.

Whatever be the position of the plate of the dial, the position of the hour-lines upon it is a matter of mere technical calculation, for which the formulæ and principles of spherical trigonometry are necessary, but which is not attended with any difficulty.

\* Vol. i. page 102.

## COMMON THINGS—CLOCKS AND WATCHES.

It must, however, be observed, that generally the hour-lines are inclined to each other at unequal angles, as may be seen by inspecting any ordinary sun-dial. There is one, and one only, position which could be assigned to the plate of the dial, such that the hour-lines would make equal angles with each other. That position would be at right angles to the gnomon, and a dial so constructed would be suitable to any place, whatever be its latitude. All that would be necessary would be to set it so that the gnomon would be directed to the celestial pole. The sun, however, would shine upon the upper or north side of it during the spring and summer, and on the lower or south side during the autumn and winter. It would, therefore, be necessary that it should be marked on both sides with hour-lines, and that a gnomon should be fixed on both sides.

6. The name dial is derived from the Latin word *dies*, a day, and the invention and use of the instrument as a time indicator is very ancient. According to Herodotus, the invention came to Greece from Chaldæa. The first dial recorded in history is the hemisphere of Berosus, who is supposed to have lived 540 B.C.

7. The first attempts to measure time by motions artificially produced, consisted in arrangements, by which a fluid was let fall in a continuous stream through a small aperture in the pipe of a funnel, the time being measured by the quantity of the fluid discharged. The CLEPSYDRA, or water-clock, of the ancients, was constructed upon this principle. This and the sun-dial were the only instruments contrived or used by the ancients for the measurement of time.

Clepsydras were contrived by the Egyptians, and were in common use under the reign of the Ptolemys. In Rome, sun-dials were used in summer and clepsydras in winter. These instruments, though subject to very obvious defects, were, nevertheless, when skilfully used, susceptible of considerable accuracy, as may be easily conceived, when it is stated, that before the invention of clocks and watches, they were the only chronometric instruments used by astronomers. The chief sources of their irregularities were the unequal celerity with which the fluid is discharged, owing to its varying depth in the funnel and its change of temperature.

8. The common hour-glass comes under this class of chronometric instruments, but is the most imperfect of them. Nevertheless, for certain purposes, it is even now, advanced as we are in the application of science to the arts, still found the most convenient chronometer. The process of ascertaining a ship's rate of sailing or steaming by means of the log affords an example of its use. One man holds the reel from which the line runs off, while another holds the

## CLEPSYDRA—SAND-GLASS.

sand-glass, and gives the signal when the sand has run out. The number of knots run off from the reel is then the number of miles per hour in the rate of the vessel. The intervals between the knots, the quantity of sand in the glass, and the aperture through which it falls, are so adapted to each other as to give this result.

9. Notwithstanding the great perfection to which the art of constructing chronometers has attained, an apparatus was not long since proposed by the late Captain Kater for the measurement of very small intervals of time, fractions of a second, for example, which is a modification of the clepsydra. A quantity of pure and clean mercury is poured into a funnel with a small aperture at its apex, so that a stream of the quicksilver shall fall through it. The flow is rendered uniform, by keeping the mercury in the funnel at a constant level. The apparatus is intended in scientific researches to note the exact duration of phenomena, and it is so managed, that the stream issuing from the funnel, is turned over a small receiver at the instant the phenomenon to be observed commences, and is turned away from it the instant the phenomenon ceases. The mercury discharged into the receiver is then accurately weighed, and the number of grains, and parts of a grain it contains, being divided by the number of grains which would be discharged in a second, the number of seconds, and the parts of a second, which elapsed during the continuance of the phenomenon is found.

10. For the purposes of civil life, as well as for the more precise objects of scientific research, all these contrivances have been superseded by clocks and watches, which are now so universal as to constitute a necessary article of furniture in the most humble dwellings, and a necessary appendage of the person in all civilised countries.

All varieties of this most useful mechanical contrivance include five essential parts.

1. A moving power.
2. An indicator, by whose uniform motion time is measured.
3. An accurately divided scale, upon which the indicator moves and by which its motion is measured.
4. Mechanism, by which the motion proceeding from the moving power is imparted to the indicator.
5. A regulator, which renders the motion imparted to the indicator uniform, and which fixes its celerity at the required rate.

Thus, for example, in a common clock, the moving power is the weight suspended by cords over a pulley fixed upon the axle of a wheel, to which the weight in descending imparts a motion of rotation. The indicator is the hand. The scale is the dial plate



## COMMON THINGS—CLOCKS AND WATCHES.

upon which the hours, minutes, and sometimes the seconds, are marked by equal divisions, over which the point of the hand moves. The mechanism is a train of wheelwork, so constructed that the rate of rotation of the last wheel upon the axle of which the hand is fixed, shall have a certain proportion to the rate of rotation of the first wheel, upon the axle of which the weight is suspended. And if, as is generally the case, there be two or three hands, then the wheel-work is so constructed, that while one of the hands makes one revolution, another shall make twelve revolutions, and the third shall make sixty revolutions during a single revolution of the latter, and therefore seven hundred and twenty during a single revolution of the former.

If no other appendage were provided, the weight would, in such an apparatus, descend with a continually increasing velocity, and would therefore impart to the hands a motion of rotation more and more rapid, which would not consequently serve as a measure of time. This defect is removed by the addition of a pendulum, combined with a wheel upon which it acts called the escapement. It is the property of the pendulum that its oscillations are necessarily made always in equal times, and its connection with the escapement-wheel is such, that one tooth of that wheel, and no more, is allowed to pass the upper part of the pendulum during each oscillation right and left. But this escapement-wheel itself forms part of the train of wheelwork by which the first wheel, moved by the descending weight, is connected with the wheels which move the hands, and consequently, by regulating and rendering uniform the motion of this escapement-wheel, the pendulum necessarily regulates and renders uniform the motion of the entire apparatus.

The instrument thus arranged, therefore, imparts an uniform motion of rotation to each of the hands, but this is not enough to render it a convenient time measurer. It is necessary that the motion of the hands should have some definite and simple relation to the natural and conventional division of time into days, hours, minutes, and seconds. For this purpose it is required not only that the hands should move uniformly, but that the first, or slowest of them, should make two complete revolutions in a day, or a single revolution in twelve hours; and, as a necessary consequence of this, that the second should make a single revolution in an hour, and the third in a minute.

11. From what has been stated, it will be apparent that the actual rate of motion imparted to the hands will be determined by the rate of oscillation of the pendulum. It has been shown that for each oscillation, right and left, of the pendulum, one tooth of the escapement-wheel passes, and if the escapement-wheel have

## THE PENDULUM.

thirty teeth, and if the pendulum take one second to make a single swing, it will allow the escapement-wheel to make a complete revolution while it makes thirty swings from right to left, and thirty from left to right, that is, in sixty seconds, or one minute; so that, if the axis of the third hand were in this case fixed upon the axle of the escapement-wheel, that hand would make one complete revolution in a minute, and consequently the second would make one complete revolution in one hour, and the third in twelve hours. The required conditions would therefore be in this case fulfilled.

To render this explanation of the regulating property of the pendulum complete, it will be sufficient to show—1st, that the time of vibration must be always rigorously the same with the same pendulum; 2nd, that this time can be made shorter or longer by varying the length of the pendulum, so that a pendulum can always be constructed which will vibrate in one second, or in half a second, or, in short, in any desired time; and 3rd, that the connection of the pendulum with the escapement-wheel can be so constructed, that the motion of the latter shall be governed by the vibrations of the former, in the manner already described.

A pendulum consists of a heavy mass attached to a rod, the upper extremity of which rests upon a point of support in such a manner as to have as little friction as possible. Such an instrument will remain at rest when its centre of gravity is in the vertical line immediately under the point of suspension or support. But if the centre of gravity be drawn from this position on either side, and then disengaged, the instrument will swing horizontally from the one side to the other of the position in which it would remain at rest, the centre of gravity describing alternately a circular arc on the one side or the other of its position of rest. If there were neither friction nor atmospheric resistance, this motion of vibration or oscillation on either side of the position of equilibrium would continue for ever; but in consequence of the combined effects of these resistances, the distances to which the pendulum swings on the one side and on the other are continually diminished, until, after the lapse of an interval, more or less protracted, it comes to rest.

12. It is related that Galileo, when a youth, happening to walk through the aisles of a church in Pisa, observed a chandelier suspended from the roof, whose position had been accidentally disturbed, and which was consequently in a state of oscillation. The young philosopher, contemplating the motion, was struck with the fact, that although the range of its vibration was continually diminished as it approached a state of rest, the times of the vibration were sensibly equal, the motion becoming slower

## COMMON THINGS—CLOCKS AND WATCHES.

as the range of the oscillations became more limited. This led him to infer that property of the pendulum expressed by the word *isochronism*, in virtue of which the vibrations, whether in longer or shorter arcs, are performed in the same time.

Although, however, as we shall presently show, pendulums possess this property when the arcs of vibration are very small, they do not continue to manifest it when the range of vibration becomes more considerable.

13. To simplify the exposition of the important theory of the pendulum, it will be convenient, in the first instance, to consider it as composed of a heavy mass of small magnitude, suspended by a wire or a string, the weight of which may be neglected. Thus, let us suppose a small ball of lead suspended by a fine silken string, the length of which is incomparably greater than the diameter of the leaden ball. Such an arrangement is called the *simple pendulum*.

Let *s*, fig. 1, be the point of suspension; let *s B* be the fine silken thread by which the ball *B* is suspended, and the

Fig. 1.

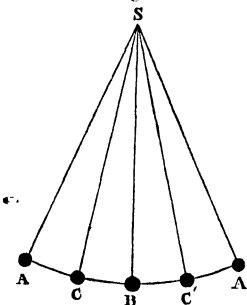

weight of which, in the present case, is neglected. Let *B* be the position of the ball when in the vertical under the point of suspension *s*. In that position the ball would remain at rest; but if we suppose the ball drawn aside to the position *A*, it will, if disengaged, fall down the arc *A B*, of which the centre is *s*, and the radius the length of the string. Arriving at *B*, it will have acquired a certain velocity, which, in virtue of its inertia, it will have a tendency to retain, and with this velocity it will commence to move through the arc *B A'*. Supposing neither the

resistance of the atmosphere nor friction to act, the ball will rise through an arc *B A'* equal to *B A*; but it will lose the velocity which it had acquired at *B*; for it is evident that it will take the same space, and the same time, to destroy the velocity which has been acquired, as to produce it. Thus, the velocity at *B*, being acquired in falling through the arc *A B*, will be destroyed in rising through the equal arc *B A'*.

Having arrived at *A'*, the ball, being brought to rest, will again fall from *A'* to *B*, and at *B* will have again acquired the same velocity which it had obtained in falling from *A* to *B*, but in the contrary direction; and in the same manner it may be explained that this velocity will carry it from *B* to *A*. Having

## ISOCHRONISM.

arrived at A, the ball, being again brought to rest, will fall once more from A to B, and so the motion will be continued alternately between A and A'.

The motion of the pendulum from A to A', or from A' to A, is called an *oscillation*, and its motion between either of those points and B is called a semi-oscillation, the motion from B to A or from B to A' being called the ascending semi-oscillation, and the motion from A or A' to B, the descending semi-oscillation.

The time which elapses during the motion of the ball between A and A' is called the *time of one oscillation*.

It is evident, from what has been stated, that the time of moving from either of the extremities A, A', of the arc of oscillation to the point B, is half the time of an oscillation.

If, instead of falling from the point A, the ball had fallen from the point c, intermediate between A and B, it would have then oscillated between c and c'; two points equally distant from B, and the arc of oscillation would have been c c', more limited than A A'.

But in commencing its motion from c, the declivity of the arc down which it falls towards B would be evidently less than the declivity at A; consequently the force which would accelerate it, commencing its motion at c, would be less than that which would accelerate it, commencing its motion at A. The ball, therefore, commencing its motion at A, would be more rapidly accelerated than when it commences its motion at c.

The result of this is, that, although the arc A B may be twice as long as the arc c B, the *time* which the ball takes to fall from A to B will not be sensibly different from the time it takes to fall from c to B, provided that the arc of oscillation A B A' is not considerable.

It was at first supposed, as we have just stated, that, whether the oscillations were longer or shorter, the times would be absolutely the same. Accurately speaking, however, this is not the case: but if the total extent of the oscillation A A' do not exceed  $5^{\circ}$  or  $6^{\circ}$ , then the time of oscillation in it may be considered, practically, the same as in the lesser arcs.

14. This important principle may be easily experimentally verified. Let two small leaden balls be suspended from the same point of support, but one being in advance of the other, so that in oscillating the two balls shall not strike each other. This being done, let one of the balls be drawn from its point of rest through an angle less than  $3^{\circ}$ , and let it be disengaged. It will oscillate as described above. Let the other ball be now drawn from its point of rest through a much less angle, and let it be so

## COMMON THINGS—CLOCKS AND WATCHES.

disengaged that it shall commence its oscillation at the same moment with the commencement of one of the oscillations of the other ball.

Let it, in short, be so managed, that when the one ball is at *A*, the other shall be at *c*; and that both shall commence their descending motion towards *B* at the same moment. It will be then found that their oscillations will be synchronous for a considerable length of time, that is to say, the balls will arrive at *A'* and *c'*, respectively, at the same instant; and returning, will simultaneously arrive at *A* and *c* respectively.

If, in this case, the oscillation of the ball *A* were made through an arc, even as great as  $10^\circ$ , that is to say,  $5^\circ$  each side of the vertical, the oscillation of the ball *c* being made through an arc of  $2^\circ$ , it would be found that 10001 oscillations of the latter would be equal to 10000 oscillations of the former, so that the actual difference between their times of oscillation would not exceed the ten thousandth part of such time.

15. In the practical application of the pendulum, however, this departure from absolute isochronism, small as it is, becomes unimportant; for a power is always provided, by which the loss of motion which would be produced by friction and atmospheric resistance is repaired, and the magnitude of the oscillations is maintained uniform, as we shall presently show.

16. It might be expected that the time of oscillation of different pendulums would depend, more or less, upon the weight of the matter composing them, and that a heavy body would oscillate more rapidly than a lighter one. Both theory and experience, however, prove the result to be otherwise. The force of gravity which causes the pendulum to oscillate acts separately on all the particles composing its mass; and if the mass be doubled, the effect of this force upon it is also doubled; and, in short, in whatever proportion the mass of the pendulum be increased or diminished, the action of the force of gravity upon it will be increased or diminished in exactly the same proportion, and consequently the velocity imparted by gravity to the pendulous mass at each instant will be the same.

It is easy to verify this by experiment. Let different balls of small magnitude, of metal, ivory, and other materials, be suspended by light silken strings of the same length, and made to oscillate; their oscillations will be found to be equal.

17. If pendulums of different lengths have similar arcs of oscillation, the times of oscillation of those which are shorter will be less than the times of oscillation of those which are longer. Let *a*, *b*, *c*, *d*, and *e*, fig. 2, be five small leaden balls, suspended by light silken strings to the point of suspension *s*, and let all

## RATE OF PENDULUM.

of them be supposed to form pendulums, having the same angle of oscillation. The arc of oscillation of the ball  $a$  will be  $a a'''$ ,

that of  $b$  will be  $b b'''$ , that of  $c$ ,  $c c'''$ , and so on. In commencing to fall from the points  $a, b, c, d, e$  towards the vertical line, these five balls are equally accelerated, inasmuch as the circular arcs down which they fall are all equally inclined at this point to the vertical line. The same will be true if we take them at any corresponding points, such as  $a', b', c', d', e'$ . It may therefore be concluded, that throughout the entire range of oscillation of each of these five pendulums, they will be impelled by equal accelerating forces.

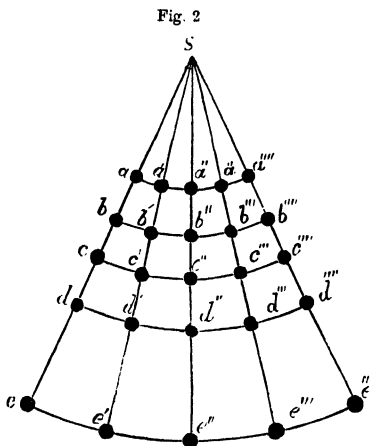

Now it is shown by the principles of mechanics, that when bodies are impelled by the same or equal accelerating forces, the spaces through which they move are proportional to the squares of the times of their motion; therefore it follows, that the lengths of these arcs of oscillation are proportional to the squares of the times. But the lengths of these arcs are evidently in the same proportion as the lengths of the pendulums, that is to say, the arc  $a a'''$  is to  $b b'''$  as  $s a$  is to  $s b$ , and the arc  $b b'''$  is to  $c c'''$  as  $s b$  is to  $s c$ , and so on.

It follows, therefore, that the squares of the times of oscillation of pendulums are as their lengths, or, what is the same, the times of oscillation are as the square roots of their lengths. This principle is easily verified experimentally.

Let three small leaden balls be suspended vertically under each other by means of loops of silken thread, as represented in fig. 3, and in such a manner that they can all oscillate in the same plane at right angles to the plane of the diagram, the suspending loops not interfering with each other.

Let the loops be so adjusted that the distance of the ball 1 below the line  $m n$  shall be 1 foot, the distance of the ball 4, 4 feet, and the distance of the ball 9, 9 feet.

Let the ball 9 be put in a state of oscillation through small arcs, and let the ball 4 be then drawn from its vertical position,

## COMMON THINGS—CLOCKS AND WATCHES.

and disengaged so as to commence one of its oscillations with an oscillation of the ball 9; and in the same manner let the ball 1 be started simultaneously with one of the oscillations of the ball 9.

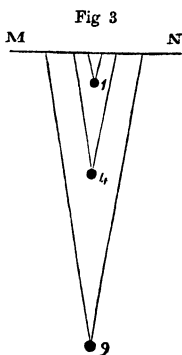

It will be found that two oscillations of the one-foot pendulum are made in exactly the same time as a single oscillation of the four-foot pendulum; consequently, the time of each oscillation of the latter will be double that of the former, while its length is fourfold that of the former.

In the same manner, while the one-foot pendulum makes three oscillations, the nine-foot pendulum will make one, and, consequently, the time of oscillation of the latter will be three times that of the former, while its length is nine times that of the former.

By this principle, the length of a pendulum which would oscillate in any proposed time, or the time of oscillation of a pendulum of any proposed length can be ascertained, provided we know the length of a pendulum which oscillates in any given time.

18. We have hitherto supposed that the pendulous body is a heavy mass of indefinitely small magnitude, suspended by a wire or string having no weight. These are conditions which cannot be fulfilled in practice. Every real pendulous body has a definite magnitude, its component parts being at different distances from the point of suspension; the rod which sustains it is of considerable weight, and all the points of this rod, as well as those of the pendulous mass itself, are at different distances from the point of suspension. In estimating, therefore, the effect of pendulums, it is necessary to take into account this circumstance.

Let us suppose *a, b, c, d, e, f, g* (fig. 4), to be as many small heavy balls connected by independent strings, the weight of which may be neglected, with a point of suspension *s*, and let these seven balls be supposed to vibrate between the positions *s m* and *s m'*. Now if these balls were totally independent of each other, and connected with the point of suspension by independent strings, they would all vibrate in different times, those which are nearer the point *s* vibrating more rapidly than those which are more distant from it. If, therefore, they be all disengaged at the same moment from the line *s m*, those which are nearest to *s* will get the start of those which are more distant, and at any intermediate position between the extremes of their

## CENTRE OF OSCILLATION.

vibration they will assume the positions  $a', b', c', d', e', f', g'$ . That which is nearest to the point  $B$ , and which is the shortest pendulum, will be foremost, since it has the most rapid vibration. The next in length,  $b'$ , will follow it, and so on; the most remote from  $s$  being the longest pendulum,  $g'$  being the last in order.

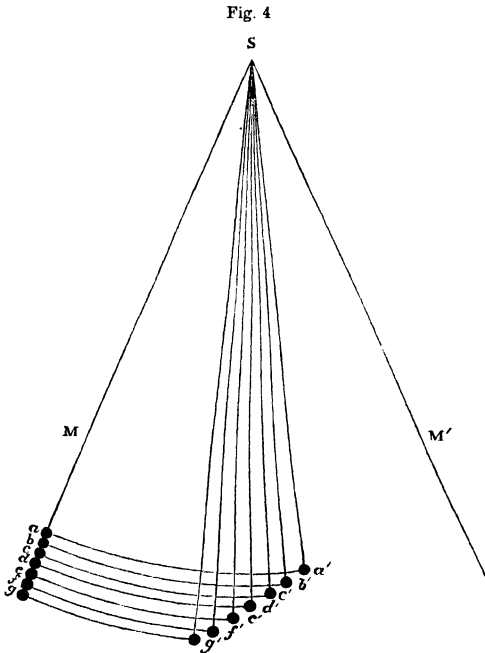

Now if, instead of supposing these seven balls to be suspended by independent strings, we imagine them to be fixed upon the same wire, so as to be rendered incapable of having any independent motion, and compelled to keep in the same straight line; then it is evident, that while the whole series vibrates with a common motion, those which are nearest to the point of suspension will have a tendency to accelerate the motion of those which are more distant, while those which are more distant will have a tendency to retard the motion of those which are nearer.

These effects will produce a mutual compensation;  $b$  and  $c$  will vibrate slower than they would if they were moving freely, while  $e$  and  $f$  will evidently move more rapidly than if they were moving



## COMMON THINGS—CLOCKS AND WATCHES.

freely. Among the series, there will be found a certain point, which will separate those which are moving slower than their natural rate, from those which are moving faster than their natural rate; and a ball placed at this point would vibrate exactly as it would do if no other balls were placed either above or below it. Such a ball would, as it were, be the centre which would divide those which are accelerated from those which are retarded.

Such a point has, therefore, been denominated the *centre of oscillation*.

It is evident then, that a pendulous mass, of magnitude more or less considerable, will vibrate in the same time as it would do if the entire mass were concentrated at its centre of oscillation, and formed there a material point of insensible magnitude.

By the length of a pendulum, no matter what be its form, is always to be understood the distance of its centre of oscillation from its point of suspension.

It will be seen from what has been explained above, that by varying the distance of the centre of gravity of the pendulum from the point of suspension, the centre of oscillation, and therefore the virtual length of the pendulum, and consequently its time of vibration, may be varied. The instrument may therefore be so adjusted, that the time of its vibration shall be a second, or any fraction of a second, that may be desired.

19. Supposing, then, the pendulum to be so adjusted, that it shall make its vibrations at any required rate, one per second for example, let us see how the motion of the indicating hands is governed by such vibrations.

Upon the axis on which the pendulum oscillates is fixed a piece of metal in the form of an anchor, such as  $D B A C$  (fig. 5), so that this piece shall swing alternately right and left with the pendulum. Two short pieces,  $m$  and  $m'$ , called pallets, project inwards at right angles to it from its extremities  $A$  and  $C$ .

The form and dimensions of the anchor  $A B C$  are accommodated to those of the escapement-wheel,  $w w'$ , which is part of the clockwork, and which, in common with the other wheels forming the train, is moved in the direction indicated by the arrow by the weight or main-spring. When the anchor swings to the right the pallet  $m$  enters between two teeth of the wheel, the lower of which coming against it, the motion of the wheel is for the moment arrested. When it swings to the left, the pallet  $m$  is withdrawn from between the teeth, and the wheel is allowed to move, but only for a moment, for the other pallet  $m'$  enters

## ESCAPEMENT.

between two teeth at the other side, the upper of which coming against it the motion of the wheel is again arrested.

The wheel, therefore, is thus made to revolve on its axis, E, not with a continuous motion, as would be the case if it were impelled by the weight or mainspring, without the interference of any obstacle, but with an intermitting motion. It moves by starts, being stopped alternately by one pallet or the other coming in the way of its teeth.

When the pendulum, and therefore the anchor, is at the extreme right of its play, the pallet, *m*, having entered between two teeth, a tooth rests against its lower side, the wheel is arrested, and the pallet, *m'*, is quite disengaged from, and clear of, the teeth of the wheel.

When in swinging to

the left the arm *D B* becomes vertical, the tooth of the wheel on the left has just *escaped* from the pallet, *m*, and the wheel being liberated, has just commenced to be moved by the force of the weight or mainspring. But at the same moment the pallet, *m'*, enters between the teeth of the wheel on the right, and when the anchor has arrived at the extreme left of its play, the tooth of the wheel, which is above the pallet, *m'*, will have fallen upon it, so that the motion will again be arrested.

Thus it appears, that during the first half of the swing from right to left, the motion of the wheel is arrested by the pallet, *m*, and during the remaining half of the swing the wheel moves, but is arrested the moment the swing is completed.

In like manner it may be shown, that during the first half of the swing from left to right, the motion of the wheel is arrested by the pallet, *m'*, that it is liberated and moves during

Fig 5

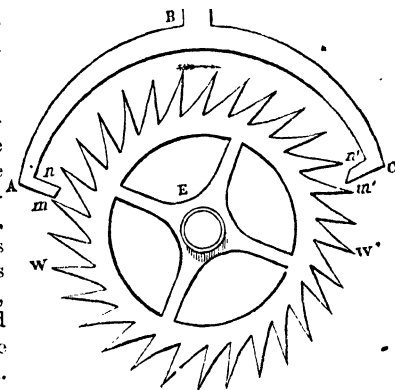

## COMMON THINGS—CLOCKS AND WATCHES.

the latter half swing, and is again arrested when the swing is completed.

20. The motion which is imparted to the hands upon the dial necessarily corresponds with this intermitting motion of the escapement-wheel. If the clock be provided with a seconds-hand, the circumference of the dial being divided into sixty equal parts by dots, the point of the seconds-hand moves from dot to dot during the second half of each swing of the pendulum, having rested upon the dot during the first half swing.

The whole train of wheel-work being affected with the same intermitting motion, the minute and hour hands must move, like the second hand, by intervals, being alternately moved and stopped for half a second. This intermission, however, is not so observable in them as in the seconds-hand, owing to their comparatively slow motion. Thus, the minute-hand moving sixty times slower than the seconds-hand, moves during each half swing of the pendulum through only the sixtieth part of the space between the dots, and the hour-hand moving twelve times slower than the minute-hand moves in each half swing of the pendulum, through the 360th part of the space between the dots. It is easy, therefore, to comprehend how changes of position so minute are not perceptible.

21. If the pendulum vibrated upon its axis of suspension unconnected with the clockwork, the range of its oscillation would be gradually diminished by the combined effects of the friction upon its axis and the resistance of the air, and this range thus becoming less and less, the oscillation would at length cease altogether, and the pendulum would come to rest. Now this not being the case when the pendulum is in connection with the wheelwork, but on the contrary, its oscillations having always the same range, it is evident that it must receive from the escapement-wheel some force of lateral impulsion, by which the loss of force caused by friction and the resistance of the air is repaired.

It is easy to show how the effect is produced. It has been shown that during the first half of each swing, a tooth of the escapement-wheel rests upon one or other pallet of the anchor. The pallet re-acts upon it with a certain force, arresting the motion of the wheelwork, and receives from it a corresponding pressure. This pressure has a tendency to accelerate the motion of the pendulum, and this continues until the tooth slips off, and is liberated from the pallet. It is this force which repairs the loss of motion sustained by the pendulum by friction and atmospheric resistance.

Thus we see, that while on the one hand the pendulum regulates and equalises the motion imparted to the wheelwork by the weight or mainspring, its own range is equalised by the reaction of the weight or mainspring upon it.

Fig 13.

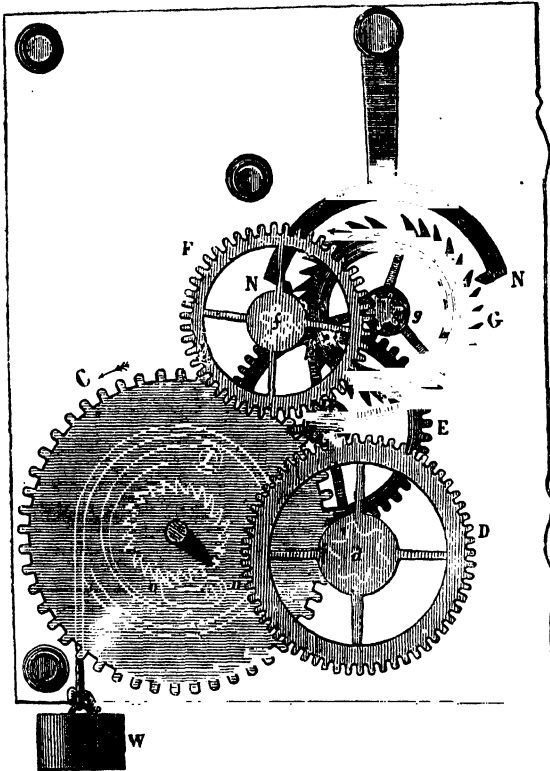

## COMMON THINGS.

### CLOCKS AND WATCHES.

#### CHAPTER II.

22. Action of pendulum on escapement wheel.—23. Rate of motion of hands produced by tooth and pinion work.—24. Method of making pinions.—25. Mutual action of toothed wheels.—26. Wheel and pinion.—27. Bevelled and crown wheels.—28. Weight applied as a moving power.—29. Why hands not turned back when clock is wound up.—30. Mainspring.—31. Its power variable.—32. The fusee.—33.

## COMMON THINGS—CLOCKS AND WATCHES.

Balance-wheel.—34. Its vibrations uniform.—35. General explanation of a watch.—36. Of a clock moved by a weight.—37. Method of regulating the rate.

22. If the action of the anchor of the pendulum upon the escapement-wheel be attentively considered, it will be perceived that one tooth only of the escapement passes the anchor for each double vibration made by the pendulum. Thus, if we suppose that when the pendulum is at the extreme left of its range, the right-hand pallet is between the teeth  $m'$  and  $n'$ , the tooth  $n'$  will escape from the pallet  $c$  when the pendulum, swinging from left to right, comes to the vertical position, which is the middle of its swing. While it rises to the extreme right of its range, the tooth  $n'$  advances to the place which  $m'$  previously occupied, and at the same time the tooth  $m$  advances to the place which  $n$  previously occupied; but, at the same time, the pallet  $a$ , carried to the right, enters between  $m$  and the succeeding tooth, and arrests the further progress of the wheel. When the pendulum then swings to the left, the wheel continues to be arrested until it arrives at the middle of its swing, when the tooth below  $m$  escapes from the pallet  $a$ , but at the same moment the pallet  $c$  enters below the tooth which is above  $n'$ , and receiving it at the end of the swing, stops the motion of the wheel. Thus it appears, that tooth after tooth, in regular succession, falls upon the pallet  $c$  upon the arrival of the pendulum at the extreme left of its play after each double oscillation.

If the pendulum be so constructed that it shall vibrate in a second, and that it be desired that the escapement-wheel shall make a complete revolution in a minute, that is during sixty vibrations of the pendulum, the wheel must have thirty teeth. In that case, one tooth passing the anchor during each double oscillation from right to left, and back from left to right, thirty teeth, that is the whole circumference of the wheel, will pass the anchor in thirty double oscillations, or in sixty single swings of the pendulum, the time of each swing being one second.

23. The manner in which different rates of revolution can be imparted to the different hands of a clock or watch, by tooth and pinion work, is easily rendered intelligible.

The wheels commonly used in watch and clockwork are formed from thin sheets of metal, usually brass, which are cut into circular plates of suitable magnitude, upon the edges of which the teeth are formed. The edges of the wheels thus serrated are brought together, the teeth of each being inserted between those of the other, so that if one be made to revolve upon its axle, its teeth pressing upon those of the other, will impart a motion of revolution to the other.

## WHEELS AND PINIONS.

When a large wheel works in the teeth of a much smaller one, which is a very frequent case in all species of wheelwork, the smaller wheel is called for distinction a **PINION**, and its teeth are called **LEAVES**. \*

24. The method of manufacturing the pinions and smaller wheels used in watch and clockwork is very ingenious. A rod of wire, the diameter of which a little exceeds that of the wheel or pinion to be made, is drawn through an aperture cut in a steel plate, having the exact form and magnitude of the wheel or pinion to be formed. After being forced through this aperture by the ordinary process of wire-drawing, it is converted into a *fluted wire*, the ridges of the fluting corresponding exactly in form and magnitude to the edge of the aperture, and therefore to the teeth or leaves of the pinion or wheel.

This fluted wire, called *pinion wire*, is then cut by a cutter, adapted to the purpose, into thin slices, at right angles to its length. Each slice is a perfect wheel, or pinion; and it is evident that all of them must be absolutely identical in form and magnitude.

Such a wire-drawing plate, with apertures of different forms and sizes, is represented in fig. 6.

Fig. 6.



25. Two wheels of unequal magnitude, working one in the other, are represented in fig. 7. It will be easily perceived, that in this case their motions must be in contrary directions. Thus, if the wheel A move in the direction of the hand of a watch, the wheel B must move in the contrary direction.

Fig. 7.

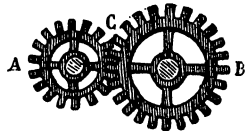

Also, the rate at which they revolve on their axles will be in the inverse proportion of the number of their teeth. Thus, if the wheel B have fifty teeth, while the wheel A has only ten, it is evident that one revolution of B must be accompanied by five revolutions of A, since an equal number of teeth of each wheel must necessarily pass the point of contact c in the same time.

Now, in clock and watchwork, one of the objects to be attained is to cause certain wheels to revolve in a given numerical proportion to others. Thus, that upon the axis of which the seconds

## COMMON THINGS—CLOCKS AND WATCHES.

hand is fixed must make sixty revolutions, while that upon which the minute hand is fixed makes one. This would, therefore, be accomplished if the two wheels worked one in the other, the one having ten teeth and the other six hundred. But it is not necessary or convenient that the two wheels should thus be immediately in connection. Two or more wheels or pinions may be interposed between them, so that their relative velocities of rotation may result from the combined relations of the numbers of teeth or leaves in all the intermediate wheels and pinions.

26. A wheel working in a pinion is represented in fig. 8. When a very slow motion of rotation is to be converted into one many times faster, or *vice versâ*, this expedient is usually adopted.

A wheel and pinion are often fixed upon the same axis at more or less distance asunder. The pinion in this case may drive or be driven by a smaller wheel at a distance from the first, which is often convenient in clockwork and other machinery.

Thus, in fig. 17, the wheel *c* drives the pinion *d* which is fixed upon the axle of *b*, and drives it. The wheel *b* drives the pinion *e*, which drives the wheel *F* on the same axle, and the wheel *F* drives the pinion *f*, which drives the wheel *F*, and so on. In this way combinations of wheels and pinions may be arranged so as to modify in any desired manner the rate of rotation, and to transfer the rotation from axle to axle according to any proposed conditions.

27. In all these cases the axles round which the motion of rotation is produced are parallel one to another. In many cases, as well in clockwork as in other machinery, it is required to produce a motion of

Fig. 8.

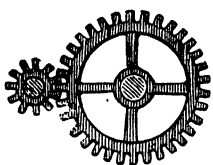

u

Fig. 9.

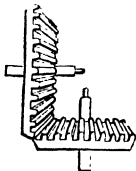
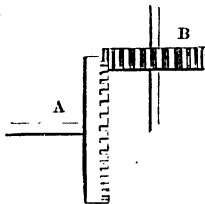

Fig. 10.



rotation round an axis at right angles to that upon which the motion already obtained is produced.

This is very simply and beautifully effected by either of two expedients, one of which is called **BEVELLED**, and the other **CROWN** wheels.

## CLOCK WEIGHT.

The manner in which the object is attained by bevelled wheels will be evident by inspecting fig. 9. The teeth in this case are formed upon a surface inclined to the axis at an angle of  $45^\circ$ , and the two axes make with each other consequently an angle of  $90^\circ$ .

In the crown wheel A, fig. 10, the teeth are raised upon the edge parallel to the axis, and work in the teeth or leaves of a wheel or pinion B, whose axle is at right angles to that of A.

In clockwork, the crown wheel is the expedient used for this purpose, bevelled wheels being generally preferred in larger and heavier applications of wheelwork.

28. It has been already stated that the moving power applied to clock or watchwork is either a weight or a mainspring.

If a weight be the moving power, it is suspended to a cord which is coiled upon a drum fixed upon an horizontal axis, the first wheel of the train which gives motion to the hands being fixed on the same axis, so that it shall turn when the drum turns.

Such an arrangement is represented in fig. 11, where A B is the drum, C D the wheel attached to it and moved by it, w the weight which is the moving power suspended to the cord E, which is coiled upon the drum A B. The end, F, of the axis of the drum projecting beyond it, is made square, so as to receive a key made to fit it, by which it is turned, so as to coil the cord upon the axis, when it has been uncoiled by the descending motion of the weight.

Fig. 11.\*

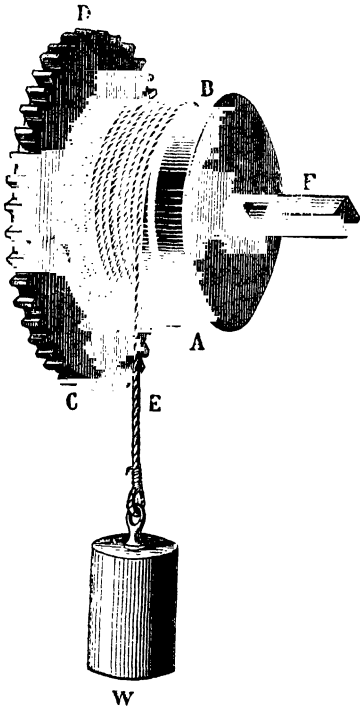

\* This, and most of the succeeding diagrams have been copied from the excellent work "Cours Élémentaire de Mécanique," par Charles Delaunay — Victor Masson—Paris, 1854, with the permission of the author and publisher.



## COMMON THINGS—CLOCKS AND WATCHES.

The direction in which the wheel *c d* is turned by the force of the descending weight is indicated by the arrow, and in that direction it will continue to turn so long as the weight acts upon the coil of the cord upon the drum. But so soon as the cord, by the continued descent of the weight, shall have been discharged from the drum, the rotation imparted to *c d* must cease. It is then that the key must be applied to the square end, *f*, of the axis of the drum, and turned continually in the direction contrary to that in which the weight would turn the drum in descending.

29. It will no doubt be perceived by the attentive reader, that, in this case, the hands of the clock would be always turned backwards while the clock is being wound up, unless some special provision were made against such an effect; for it is evident, that if the wheel *c d*, when turned by the descent of the weight *w*, in the direction of the arrow, give a progressive motion to the hands, the motion imparted to *c d*, by the ascent of the weight *w*, while the clock is being wound up, must necessarily impart to the hands a motion in the contrary direction, that is a backward motion.

In all clocks this is prevented by an expedient called a ratchet wheel and catch, the one being attached to the barrel *A B*, and the other to the face of the wheel *c d*, the effect of which is to allow the barrel *A B*, to be turned while the clock is being wound up in the direction contrary to that indicated by the arrow without turning the wheel *c d*; but when the barrel *A B* is turned by the descent of the weight *w*, in the direction of the arrow, the catch acting in the teeth of the ratchet-wheel, the motion of *A B* is imparted by the action of the catch on the ratchet-wheel to the wheel *c d*, and by it to the hands.

Fig. 12.

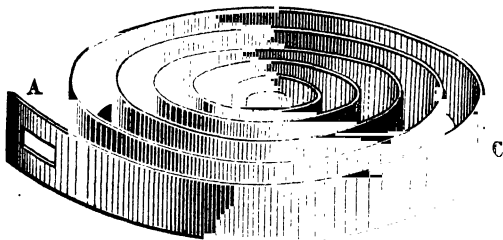

The form and mode of application of the ratchet-wheel will be presently more clearly explained.

30. The moving power of a weight can only be applied to time-

## MAINSRING.

pieces where the space necessary for the play of the weight in its descent and ascent can be conveniently obtained. This condition is obviously incompatible with the circumstances attending pocket-watches, all portable and moveable timepieces, chimney, table, and console clocks, and in general all timepieces constructed on a small scale.

The moving power applied to these universally is a mainspring, which is a ribbon of highly tempered steel bent into a spiral form, as represented in fig. 12. At one end, *A*, an eye is provided, by which that extremity may be attached either to a fixed point or to the side of the barrel to which the spring is intended to impart motion. In the centre of the spiral an arbor, or axle, is introduced, to which the inner extremity of the spring is attached. Supposing the extremity *A* to be attached to a fixed point, let the arbor *B* (fig. 13), be turned in the direction indicated by the arrow. The spring will then be coiled closer and closer round the arbor *A B*, while its exterior coils will be separated one from another by wider and wider spaces.

Fig. 13.

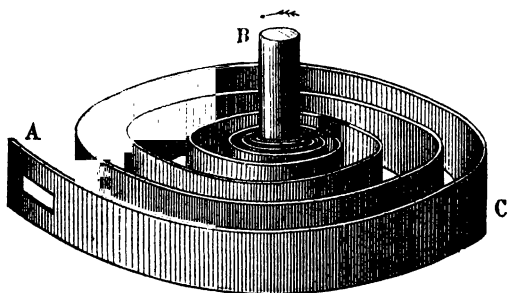

After the spring has been thus coiled up by turning the arbor, it will have a tendency to uncoil itself and recover its former state, and if the arbor *B* be abandoned to its action and be free to revolve, it will receive from the reaction of the spring a motion of revolution contrary in direction to that which was given to the arbor in coiling up the spring, and such motion would be imparted to a wheel fixed upon the axle, and might from it be transmitted to the hands in the same manner as if the arbor-wheel received its motion from the power of a weight.

31. But between such a moving force and that of a weight there is an obvious difference. The tension of the cord by which the weight is suspended, and consequently its effect in giving revolution to the barrel upon which the cord is coiled, is always

## COMMON THINGS—CLOCKS AND WATCHES.

the same until the clock altogether goes down. The moving force of the spring, on the contrary, is subject to a continual decrease of intensity. At first, when completely coiled up, its intensity is greatest, but as it turns the arbor B it becomes gradually relaxed, and its intensity is continually less and less. It exerts, therefore, a continually decreasing power upon the wheel fixed upon the arbor, and therefore upon the hands to which the motion is transmitted.

32. As a varying power would be incompatible with that uniformity and regularity which are the most essential and characteristic conditions of all forms of clockwork, such a spring would be quite unsuitable if some expedient were not found by which its variation could be equalised.

This has been accordingly accomplished, by a very beautiful mechanical contrivance, consisting of the combination of a flexible chain and a conical barrel arranged to receive its coils, called a FUSEE.

Fig. 14.

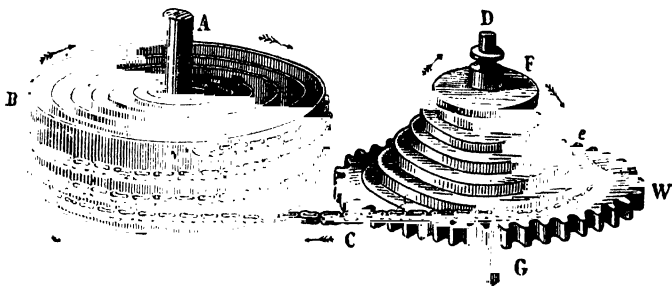

This arrangement is represented in fig. 14. The mainspring is attached by its inner extremity to the fixed arbor A, and by its outside end at E, to a barrel B, which is capable of being turned round the fixed axis A. A jointed chain is attached by one extremity to the barrel at E, and being coiled several times round it, is extended in the direction c, to the lowest groove of the fusee E, to which its other end, e, is attached. This fusee is a conical-shaped barrel, upon which a spiral groove is formed, continued from the base to the summit to receive the chain. The base is a toothed wheel, by which the motion imparted by the mainspring and chain to the fusee is transmitted to the hands through the wheelwork. The fusee is fixed upon an arbor, D G, the lower end of which, projecting outside the case containing the works, is formed square to receive a key made to fit it, by which the clock or watch is wound up.

## FUSEE.

The action of the spring transmitted by the barrel to the chain, and by the chain to the fusee, has a tendency to impart to the fusee a motion of rotation in the direction of the arrows. The fusee is connected with the wheel, *w*, by means of a ratchet-wheel and catch similar to that described in the case in which the moving power is a weight, by means of which the fusee *F* imparts rotation to the wheel when it turns in the direction of the arrows, but does not move it when turned in the opposite direction.

These arrangements being understood, let us suppose the key applied upon the square-end *a* of the arbor *D* *a* of the fusee, and let it be turned round in the direction contrary to that indicated by the arrows. The fusee will then be turned, but will not carry the wheel *w* with it; the chain *c* will give to the barrel *B* a motion of revolution contrary to the direction of the arrows, the chain will be gradually uncoiled from the barrel *B*, and will be coiled upon the spiral groove of the fusee, winding itself from groove to groove, ascending on the spiral until the entire length of the chain has been uncoiled from the barrel *B*, and coiled upon the fusee *F*, as represented in fig. 15.

During this process, the external extremity of the mainspring, attached to the barrel at *E*, is carried round with the barrel, while the internal extremity is fixed to the arbor *A*, which does not turn with the barrel. By this means the spring is more and more closely coiled round the arbor *A*, until the entire chain has been discharged from the barrel to the fusee, when the spring will be coiled into the form represented in fig. 15, and in this state the intensity of its force of recoil, and the consequent tension of the chain *c*, extended from the barrel *B* to the fusee *E*, is greatest.

Fig. 15.

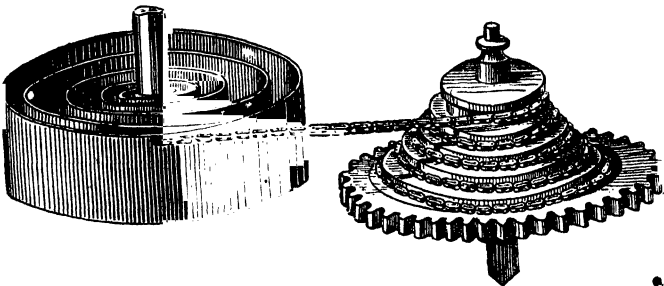

The clock being thus wound up and left to the action of the spring, the tension of the chain *c*, directed from the fusee to the

## COMMON THINGS—CLOCKS AND WATCHES.

spiral, will make the fusee revolve in the direction indicated by the arrows. This tension at the commencement acts upon the highest and smallest groove of the fusee. As the chain is gradually discharged from the fusee to the barrel, the tension is gradually decreased by reason of the relaxation of the spring, and at the same time the chain acts upon a larger and larger groove of the fusee. In this way the tension of the chain is continually decreased, and the radius of the groove on which it acts is continually increased, until the entire action has passed from the fusee to the barrel, and the clock goes down.

Now the power of the chain to impart a motion of revolution to the fusee depends on two conditions; first the force of its tension, and secondly the leverage by which this tension acts upon the fusee. This leverage is in fact the semi-diameter of the groove, upon which the chain is coiled at the point where it passes from the fusee to the barrel. Without much mechanical knowledge it will be easy to perceive that it requires less force to turn a wheel or barrel if the force be applied at a great distance from the axle than if it be applied at a small distance from it. Upon this principle generalised, it follows that the power of the tension of the chain to impart revolution to the fusee is augmented in exactly the same proportion as the magnitude of the groove on which it acts is increased.

The form given to the fusee is such that as the chain is gradually discharged from it, the diameter of the groove on which it acts increases in exactly the same proportion as that in which the tension of the chain decreases. It follows, therefore, that the power of the chain upon the fusee gains exactly as much by the increase of its leverage as it loses by the decrease of its tension, and consequently it remains invariable.

Complete compensation is therefore obtained by this beautiful and simple expedient, and a variable force is thus made to produce an invariable effect. It may be useful to state that this is only a particular application of a mechanical principle of great generality. In all cases whatever, the varying energy of a moving power may be equalised by interposing between it and the object to be moved some mechanism, by which the leverage, whether simple or complex, through which its force is transmitted, shall vary in the exact inverse proportion of the variation of the power,—increasing as the intensity of the power is decreased, and decreasing as the intensity of the power is increased.

33. Whatever be the moving power, whether it be a weight or mainspring, it would, if not controlled and regulated, impart to the hands a motion more or less accelerated, and therefore unsuitable to the measurement of time, which requires a motion rigorously

## BALANCE-WHEEL,

uniform. It is on that account that the moving power must be controlled and governed by some expedient, by which it shall be rendered uniform.

How the combination of a pendulum and escapement-wheel accomplishes this has been already explained. But this expedient requires that the timepiece to which it is applied shall be stationary; the slightest disturbance of its position would derange the mutual action of the pendulum and the escapement-wheel, and would either stop the movement, or permanently derange the mechanism. It is evident that a pendulum is not only inapplicable to all forms of pocket timepiece, but that it cannot even be used for marine purposes, the disturbances incidental to which would be quite incompatible with the regularity of its action.

The expedient which has been substituted for it with complete success in all such cases is the balance-wheel.

This is a wheel, like a small fly-wheel, having a heavy rim connected with the centre by three or more light arms, as shown at A B C, in fig. 16. Under, and parallel to it, is placed a spring resembling in form the mainspring, but much finer and lighter, and having much less force.

This spring is formed of extremely fine and highly tempered steel wire, so fine that it is sometimes called a hair-spring. One extremity of this spring is attached to the axis of the balance wheel, and the other to any convenient

fixed point in the watch. The spring is so constructed that when at rest it has a certain spiral form, to which it has a tendency to return when drawn from it on the one side or the other. If we suppose it, therefore, to be drawn aside from this position of rest and disengaged, it will return to it, but on arriving at it, having acquired by the elasticity a certain velocity, it will swing past it to the other side, to a distance nearly as far from its position of rest as that to which it had been originally drawn on the other side. It will then swing back, and will thus oscillate on the one side and the other of the position of rest, in the same manner exactly as that in which a pendulum swings on the one side or the other of the vertical line which is its position of rest.

34. The balance-wheel thus connected with a spiral spring, like the pendulum, is isochronous, that is, it performs all vibrations—long and short—in the same time. It will be recollected that this property of the pendulum depends on the fact that the

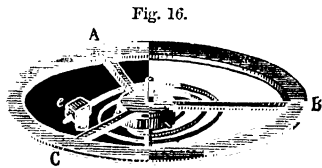

## COMMON THINGS—CLOCKS AND WATCHES.

wider is the range of its vibrations the more intense is the force with which it descends to the vertical direction, and consequently wide vibrations are performed in as short a time as more contracted ones. Now the vibrations of the balance-wheel are subject to like conditions. The wider the range of its vibrations, the more intense is the force with which the recoil of this spring carries it back to its position of rest, and consequently it swings through these wide vibrations in the same time as through more contracted ones, in which the force of the spring is proportionally less intense.

The oscillation of the balance-wheel regulates the motion of watchwork in the same manner by means of an escapement-wheel, as that in which the pendulum regulates the motion of clockwork. The pallets and the escapement-wheel are, however, very variously formed in different watches.

35. Having thus explained generally the powers by which clocks and watches are moved and regulated, it now remains to show how the necessary motions are conveyed to the hands by suitable combinations of wheels and pinions.

In fig. 17 (p. 1), are represented the works of a common watch, moved by a mainspring A, and regulated by a balance-wheel B; the wheels and pinions, however, being changed in their relative positions, and the fusee being omitted, so as to show more visibly the connections and mutual dependency of the many parts. The external extremity of the mainspring is attached to the base, o, of a column of the frame. Its internal extremity is attached to the lower end of an axle, of which the square end, T, at the top enters a hole in the dial-plate into which the key is inserted when the watch is to be wound up. The ratchet-wheel B is fixed upon this axis so as to turn with it, but the other wheel C under the ratchet-wheel is not fixed upon it, the axis being free to turn in the hole in the centre of C, through which it passes. A catch *n o* is attached by a pin on which it plays to the face of the wheel C, and its point *o* is pressed against the teeth of the ratchet-wheel B, by a spring provided for that purpose. When the key is applied upon the end T, and turned in the direction in which the hands move, the ratchet-wheel is turned with it, and the point *o* of the catch—pressed constantly against the teeth while it turns—falls from tooth to tooth with an audible click, and thus produces the peculiar sound, with which every ear is familiar, while the watch is being wound up. During this process the wheel C does not turn with the axle, which only passes through the hole in its centre without being fixed upon it, but the mainspring, A, being attached to the axle is coiled more and more closely round it, and re-acts against the fixed point o with greater and greater force.

## MECHANISM OF A WATCH.

If the fusee, which is omitted in this figure, were introduced, it would occupy the place of the spring, and would be turned by the axle imparting a like revolution to the axis of the spring by means of the chain.

When the watch is wound up, the re-action of the spring, rendered uniform in its force by the fusee, imparts a motion of revolution to the ratchet-wheel *B*, in the direction of the arrow. By this motion the tooth of the ratchet-wheel in which the point *o* of the catch is engaged, presses against the catch so as to carry it round with it in the direction of the arrow; but the catch being attached to the face of the wheel *c*, at *n*, this wheel is carried round also in the same direction, and with a common motion.

The teeth of the wheel *c* act in those of the pinion *d*, which is fixed upon the axle *d* *D*. Upon the same axle is fixed the wheel *D*, so that the wheel *D* and the pinion *d* receive a common motion of revolution from the wheel *c*.

The wheel *D*, in precisely the same manner, imparts a common motion of revolution to the pinion *e*, and the wheel *E*; and the wheel *E* imparts a common motion of revolution to the pinion *f* and the wheel *F*.

This last wheel *F* is of the form called a crown-wheel, and acts upon the pinion *g*, imparting to it, and to the escapement wheel *G*, a common motion of revolution. This escapement-wheel is acted upon and controlled by the pallets or other contrivances attached to the axis of the balance-wheel *H*, so as to regulate its motion by the oscillations of that wheel in the same manner as the escapement-wheel of a clock is regulated by the anchor of the pendulum.

It may be asked why so long a series of wheels and pinions are interposed between the mainspring and the balance-wheel? and why the first pinion *d* may not act directly upon the escapement-wheel? The object attained by the multiplication of the wheels and pinions is to cause the mainspring, by acting through a small space, to produce a considerable number of revolutions of the escapement-wheel, for without that the spring would be speedily relaxed, and the watch would require more frequent winding up. Thus by the arrangement here shown, while the mainspring causes the wheel *c* to revolve once, it causes the pinion *d* and the wheel *D* to revolve as many times as the number of teeth in *c* is greater than the number in *d*. Thus if there are ten times as many teeth in *c* as in *d*, one revolution of *c* will produce ten of *d* and *D*. In like manner if *D* have ten times as many teeth as *e*, one revolution of *D* will produce ten of *e* and *E*, and so on. In this way it is evident that one revolution of the first wheel *c*, which is on the axis of the fusee, can be made by the





## MOVEMENT OF HANDS.

produce the motion of the hands, does not differ in any important respect from the arrangement explained above. Nevertheless, it may be satisfactory to show the details of the mechanism. The train of wheels connecting the weight with the anchor of the pendulum is shown in fig. 18 (p. 17).

A side view of the mechanism, showing the wheels which more immediately govern the motion of the hands, and also the pendulum, with its appendages, is given in fig. 19 (p. 33).

The weight  $w$  acts by a cord on a barrel, as already explained. This barrel and the ratchet-wheel, with its catch, are mounted upon the axis of the great wheel  $c$ , and are behind it, as represented in fig. 18, their form and position being shown by the white lines. The catch is attached to the wheel  $c$  by the screw  $n$ , and its point  $o$  acts on the teeth of the ratchet-wheel, which is attached to the barrel on which the rope is coiled. The spring which presses the catch against the teeth of the ratchet is also shown. When the clock is wound up by the key applied to the square end  $r$  (fig. 19) of the axis of the barrel, the barrel is turned in the direction opposite to that indicated by the arrows, and the catch falls from tooth to tooth of the ratchet-wheel, making the clicking noise which attends the process of winding up. When the clock has been wound up, the weight acting on the barrel presses the tooth of the ratchet-wheel against the catch, and thereby carries round with it the wheel  $c$ . This wheel transmits the motion to the escapement wheel  $g$ , fig. 17, through the series of wheels and pinions,  $d, D, e, E, f, F$ , and  $g$ , in the same manner exactly as has been already described (35); and the pendulum, by means of the anchor  $NN$ , regulates the motion in the manner described in 19.

The wheels which more immediately govern and regulate the motion of the hands are those which appear in fig. 19 in front of the plate  $xy$ .

The pendulum consists of a heavy disc of metal, seen edgewise at  $v$  in fig. 19, attached to the end of a metal rod,  $RR$ , represented broken, to bring it within the limits of the figure. This rod is suspended by various means, but often, as in the figure, by two elastic ribbons of steel,  $ss$ , which permit its swing right and left. It passes between the prongs of a fork  $U$ , by which a rod  $rr$  is terminated, so that this rod swings right and left with the pendulum. Upon the axis of this rod, and over the escapement wheel  $g$ , is fixed the anchor  $N$  of the escapement.

37. Whether the movement be regulated by a pendulum or a balance wheel, it is necessary to provide some means of adjustment by which the rate of vibration may be increased or diminished at pleasure within certain limits, for although in its original

## COMMON THINGS—CLOCKS AND WATCHES.

construction the regulator may be made so as to oscillate *nearly* at the required rate, it cannot be made to do so *exactly*. Besides, even though it should vibrate exactly at the required rate, it will be subject, from time to time, to lose that degree of precision, and to vibrate too fast or too slowly from the operation of various disturbing causes.

It has been already shown, that the rate of vibration of the pendulum is rendered more or less rapid by transferring the centre of gravity nearer to, or farther from, the point of suspension. Upon this principle, therefore, the adjustment of the rate of vibration depends. The heavy disc *v*, fig. 19, is made to slide upon the rod *RR*, and can be moved upon it, upwards or downwards, by a fine screw attached to it, which works in a thread cut in the rod. In this manner the centre of gravity of the disc *v* may be transferred nearer to the suspension *SS*, so as to shorten the time of its vibrations, or removed farther from *SS*, so as to lengthen the time. If the clock is found to lose or go too slowly, it is screwed *up*, and if it gain or go too fast, it is screwed *down*.

In chimney and table time-pieces, the pendulum is regulated in a different manner. It is usually suspended upon a loop of silken thread, which can be drawn up or let down through a certain limited space, by means of a rod, upon which one end of the thread which forms the loop is coiled. This rod, passing through the dial-plate, has a square end, upon which a key can be applied, by turning which in the one direction or the other, the loop is drawn up or let down.

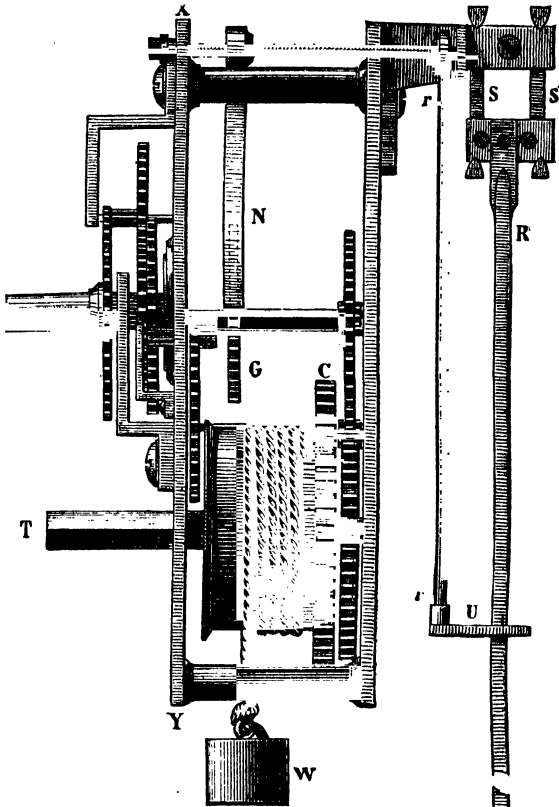

Fig. 19.

## COMMON THINGS.

### CLOCKS AND WATCHES.

#### CHAPTER III.

38. Method of regulating a balance-wheel.—39. Recoil escapement.—40. Cylindrical escapement.—41. Duplex.—42. Lever.—43. Detached.—44. Maintaining power of a clock moved by a weight.—45. Of a watch moved by a mainspring.—46. Weight or mainspring and pendulum

## COMMON THINGS—CLOCKS AND WATCHES.

and balance-wheel variously combined.—47. Watches and chronometers.—48. Marine chronometers.—49. Stationary chronometers.—50. Striking apparatus.

38. THE rate of oscillation of the balance-wheel cannot in the same manner be so easily regulated by modifying its form; but, on the other hand, while the force which moves the pendulum, being that of gravity, is beyond our control, that which moves the balance-wheel being the force of the spiral spring, is at our absolute disposition. It is accordingly by modifying this spring that we are enabled to regulate the time of oscillation of this regulator.

One of the most common expedients by which this is accomplished is represented in fig. 20.

Near the fixed point *G*, at the external extremity of the spiral, is placed a small bar *E*, near the end, *F*, of which is a notch, or hole, through which the wire of the spiral passes.

Fig 20.

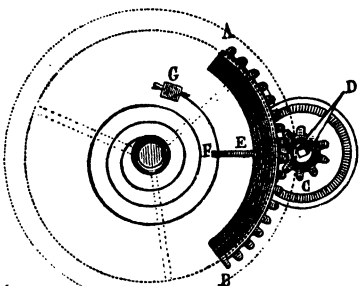

This arrests the action of the spiral, so that the only part of it which oscillates is that which is included between *F* and its internal extremity. In a word, the point *F* is the virtual external extremity of the spiral. Now this point *F* can be moved in the one direction or the other, so as to increase or diminish the virtual

length of the spiral at pleasure, by means of the toothed arc *AB* and the pinion *C*, which latter is turned by the index *D*. If the index *D* be turned to the left, the bar *E*, and the point *F*, is moved towards *G*, and the length of the spiral is increased. If it be turned to the right, the point *F* is moved from *G*, and the length of the spiral is diminished.

In this manner the rate of vibration of the balance-wheel may be adjusted by varying at will the vertical length of the spiral-spring.

39. The precision of the movement of all forms of timepieces depends in a great degree on the mechanism of the escapement, and accordingly much mechanical skill and ingenuity have been directed to its improvement, and several varieties of form have been adopted and applied.

The recoil escapement, represented in fig. 17, consists of two

## CYLINDRICAL ESCAPEMENT.

pallets, which project from the axis of the balance-wheel at right angles with each other, one of which acts at the top, and the other at the bottom of the escapement-wheel *e*, the axis of which is horizontal and the wheel vertical. These pallets, as the balance-wheel oscillates, engage alternately in the teeth of the escapement-wheel exactly in the same manner as do the pallets of the anchor of the escapement attached to the pendulum already described. This form of escapement was long the only one used, and is still continued in the more ordinary sorts of watches.

It has, however, been superseded, in watches and chronometers where greater precision is required, by others of more improved construction.

40: In pocket watches, where great flatness is required, the cylindrical escapement is used, in which the axis of the balance-wheel, instead of having pallets attached to it, is formed into a semicylinder, having a sort of notch in it, as represented on an enlarged scale in fig. 21. The semicylinder *a b*, is cut away at *c*, through about half its height. The axis *A B*, fig. 22, of the escapement-wheel is vertical, and the teeth raised at right angles

Fig 21.

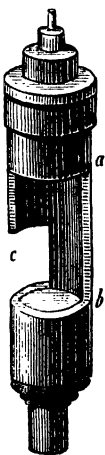
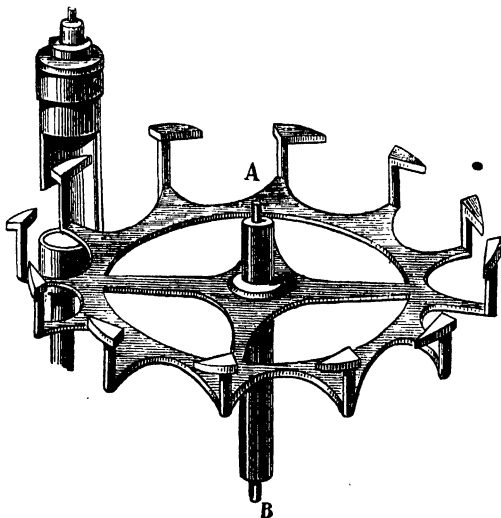

Fig. 22.



to its plane, and therefore parallel to its axis, have the peculiar form represented in the figure. As the balance-wheel oscillates on the one side and the other, the semicylinder upon its axis

## COMMON THINGS—CLOCKS AND WATCHES.

interposes itself alternately between the teeth of the escapement-wheel, stopping them and letting them escape in the usual way. The manner in which the action takes place will be more clearly understood by the figures 23 and 24, in which a view in plan upon an enlarged scale is given of the position of the semicylinder

Fig 23

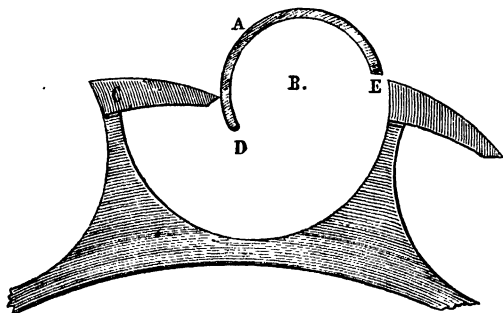

and the teeth of the escapement-wheel after each successive oscillation.

In fig. 23, the balance-wheel swinging from right to left, throws the convex side A D of the semicylinder before the tooth c of the escapement-wheel, and thus for the moment arrests it, while the side A E of the semicylinder has turned out of the way of the preceding tooth and has let it pass. The balance-wheel

Fig. 24.

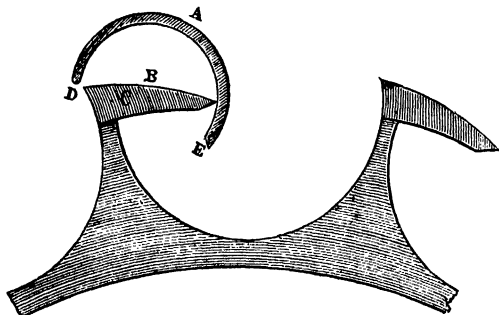

then swings from left to right, and the convex side A D of the semicylinder slides against the point of the tooth c. When the edge D of the semicylinder passes the point of the tooth, the latter in slipping over it gives to it a slight impulse, which restores to

## DUPLEX ESCAPEMENT.

the balance-wheel the small quantity of force which it lost by the previous reaction of the tooth upon its convex surface.

The side *A E* of the semicylinder is now thrown before the tooth *C*, the point of which having advanced through a space equal to the diameter of the semicylinder, is thrown against the concave surface of *A E*, as shown in fig. 24.

The balance-wheel now swinging again from right to left, the point of the tooth *C* slides upon the concave surface of the semicylinder *A E*, until the edge *E* comes to it. The tooth then slips over the inclined face of *E*, and in doing so gives the semicylinder and consequently the balance-wheel another slight impulse, restoring to it the force of which it deprived it while previously sliding upon its concave side.

The explanation here given of the action of this form of escapement is well calculated to render the conditions which all escapements should fulfil intelligible. These arrangements are primarily directed to the regulation of the movement of the wheel-work, so as to secure its uniformity. This will obviously be accomplished provided that the escapement, whatever be its form, lets a tooth of the wheel pass for each oscillation of the balance-wheel. But owing to the friction of the axis of the balance-wheel, and of the pallets on the teeth of the escapement-wheel, and the resistance of the air, the range of its oscillations would be gradually diminished, so that at last it would not be sufficient to allow the successive passage of the teeth of the escapement-wheel, and the watch would stop unless some adequate means are provided by which the balance-wheel shall receive from the mainspring through the escapement-wheel as much force as it thus loses. All escapements accomplish this by the peculiar forms given to the edges of the pallets and the teeth of the escapement-wheel. In the present case, the object is attained by making the edge *D* round and the edge *E* inclined, and by giving to the teeth the form shown in the figure.

This form of escapement supplies a sufficiently good regulating power for the best sorts of pocket watches, and is attended with the advantages of allowing the works to be compressed within a very small thickness. It is the form most commonly used in the French and Swiss watches.

41. The form of escapement used in the best English made watches consists of an escapement-wheel, which partakes at once of the double characters of a spur and crown-wheel, and is hence called the duplex escapement.

The spur teeth, *A*, *B*, *C*, &c. (fig. 25), are similar in their form and arrangement to those of the cylindrical escapement described above. The crown teeth, *a*, *b*, *c*, &c., project from the face of



## COMMON THINGS—CLOCKS AND WATCHES.

the wheel, and have a position intermediate between the spur teeth. Upon the axle of the balance-wheel just above the plane of the escapement-wheel is fixed a claw pallet called the impulse

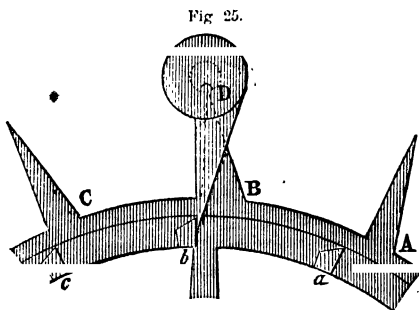

pallet, which by the combination of the oscillations of the balance and the progressive motion of the escapement-wheel falls successively between the crown-teeth of the latter, receiving from their reaction as they escape

from it, the restoring action which maintains the range of the oscillations of the balance-wheel.

Under the pallet and in the plane of the spur teeth is placed a small roller usually formed of ruby or other hard stone, having a notch on one side of it, into which the spur teeth successively fall. After any crown tooth, *a* for example passes the pallet, the corresponding spur tooth *A* falls into the notch of the roller, and this alternate action continues so long as the watch goes. It will be perceived therefore that the pallet and roller in the duplex escapement play the same part as the two edges of the semicylinder in the cylindrical escapement, and as the two pallets in the common recoil escapement (fig. 17).

The chief advantage claimed for this system is that there is but one pallet, and that the action does not require as perfect execution of the teeth of the escapement-wheel as other arrangements.

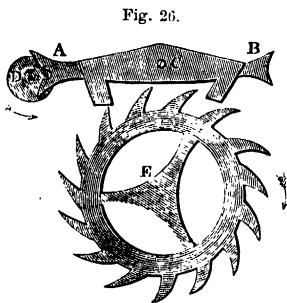

42. The lever escapement is much used for English pocket watches. A lever *AB* (fig. 26), with a notch at one end, is attached to the anchor *c*. A pin at *a*, on a disc *D*, on the verge or arbor of the balance,

enters this notch at each vibration, and first moves the dead part of the pallet off the tooth of the scape-wheel *E*, and then receives an impulse, which restores the force it has lost, leaving another tooth

## LEVER AND DETACHED ESCAPEMENTS.

engaged in the opposite pallet. As the lever is detached from the balance, except for an instant at the middle of each vibration, the amount of friction is very small. Another advantage of this movement is, that it is but little liable to derangement, and when it is injured, is easily and cheaply repaired, while the duplex and cylindrical escapements are expensive to make, and can only be mended by such skilful workmen as are not often found, except in the metropolis or large towns.

43. In the class of portable timepieces used for the purposes of navigation, where the greatest attainable regularity of motion is required, an arrangement is adopted called the detached escapement. This system is represented in fig. 27.

Upon the arbor of the balance-wheel is attached a disc, in which there is a notch *i*. A smaller disc, *g*, is also attached to it, from which a small pin projects. By the oscillations of the balance-wheel the notch *i* and the pin oscillate alternately right and left.

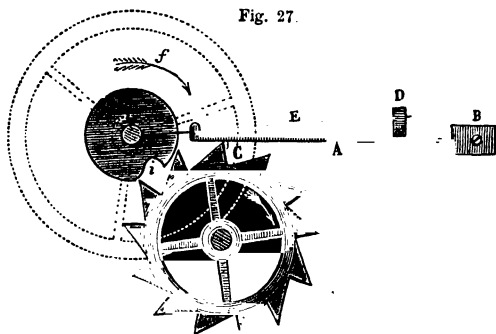

A fine flexible spring, *A*, attached to a fixed block, *B*, carries upon it a projecting piece, *C*. To the block *D* is attached another fine spring *E*, which extends to the edge of the small disc *G*. The projecting piece *C*, is so placed that when the spring *A* is not raised, it encounters a tooth of the scapewheel, but when slightly raised it allows the tooth to pass. The spring *E* rests in a small fork behind the extremity of *A*, and presented downwards.

Now, let us suppose the balance-wheel to swing from left to right. The pin, projecting from the small disc *G*, coming against the end of the spring *E*, raises it; and this spring acting in the fork behind it raises the spring *A*, and therefore lifts the piece *C*, and liberates the tooth which that piece previously obstructed. The scape-wheel therefore advances, but before the next tooth comes to the place occupied by the former one, the balance swings

## COMMON THINGS—CLOCKS AND WATCHES.

back from right to left. The spring *E* no longer supported by the fork at the end of *A*, readily lets the pin pass, and the piece *c* returning to its former position, comes in the way of the succeeding tooth and stops it.

At the moment that the balance is about to commence its swing from left to right, and when the piece *c* is about to liberate the tooth which rests against it, another tooth behind it rests against the side of the notch *i* in the disc *G*, and when the escapement-wheel is liberated, and the swing of the balance from left to right is commencing, this tooth, pressing on the side of the notch *i*, gives it and the balance-wheel an impulse which is sufficient to restore to it all the force which it lost in the previous oscillation. Except at this moment the balance-wheel in this form of escapement is entirely free from all action of the mainspring.

44. While a clock or watch is being wound up, the weight or mainspring no longer presses upon the catch nor upon the ratchet-wheel, through which the motion is imparted to the wheelwork. The motion of the hands is therefore suspended during the time occupied in winding up, consequently if the watch or clock keep regular time while it goes, it must lose just so much time as may be employed in the process of winding it up. Although this, in common clocks and watches, does not produce any sensible effect, the errors incidental to their rates of going generally exceeding it, yet in clocks used in observatories and in chronometers used for the purposes of navigation, where the greatest degree of regularity is required, provisions are made by which the motion of the clock or watch is continued notwithstanding the process of winding up.

Such expedients are called the MAINTAINING POWER.

One of the most simple arrangements by which this is accomplished in clocks moved by a weight is shown in fig. 28. The weight *P*, which is the moving power, is connected with another much smaller weight *p*, by means of an endless cord which passes over the grooves of a series of pulleys, *A*, *B*, *C*, and *D*, of which *A* and *B* are moveable, and *C* and *D* fixed. The force with which *P* descends is the excess of its weight above that of *p*.

The pulley *C*, being prevented from revolving by the catch *E* during the descent of the weight *P*, and the cord being prevented from sliding upon its groove by the effects of its friction and adhesion, the parts *b a* and *c d*, which descend from the pulley *C* to the pulleys *A* and *B*, may be regarded as being virtually attached to fixed points at *b* and *c*, so that they cannot descend. This being the case, the weight *P*, descending by its preponderance over *p*, and consequently the weight *p* being drawn up, the part of the cord *c d* must pass over the pulley *B*, the part *e f* over the pulley *D*, and the part *g h* over the pulley *A*. In this

## MAINTAINING POWER OF A CLOCK.

way the parts *ba* and *gh* will be gradually lengthened as the weight *p* descends at the expense of the parts *cd* and *fe*, which will be shortened to an equal extent, so that the weight *p* will be raised through the same space as that through which the weight *p* is lowered. During this process the wheel *D* is kept in constant revolution, and the first wheel of the train of clock-work being fixed on its axle, a motion is imparted by it through that train to the hands.

Fig. 28.

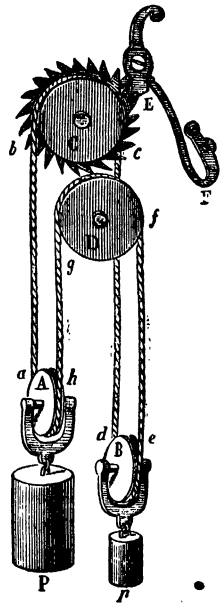

When it is desired to wind up the clock, the hand is applied to the cord *cd*, which is drawn downwards, so that the fixed pulley revolves, the catch *E* dropping from tooth to tooth until the weight *p* has been raised to the highest, and the weight *p* has fallen to the lowest point. The parts *gh* and *fe* of the cord not being at all affected by this, the pulley *D* continues to turn as before by the effect of the preponderance of *P*, which acts as powerfully while it ascends as it did when it descended.

It appears, therefore, that, by this arrangement, the motion of the works and of the hands is not suspended during the process of winding up.

45. If the works of a watch be impelled by the force of a mainspring without a fusee, in the manner represented in fig. 17, it is evident that the movement must be suspended during the process of winding up, because the ratchet-wheel *B*, by which the force of the spring is transmitted to the works, is then relieved from the action of the catch *no*. This defect may, however, in such case be removed by a very simple expedient. Instead of connecting the external extremity of the mainspring with a fixed point, let it be attached to the inside of a barrel surrounding it, and let the wheel *c* be attached to this barrel. In that case, when the axle of the ratchet-wheel is turned in winding up, and the ratchet-wheel, therefore, relieved from the action of the catch, the wheel *c* will be acted upon by the barrel, which will itself be impelled by the reaction of the external extremity of the spring which is attached to it, the winding up being effected only by the internal extremity.

This is the arrangement generally adopted in chimney and table time-pieces, as constructed in France and Switzerland, and also in

## COMMON THINGS—CLOCKS AND WATCHES.

flat watches, in all of which the adoption of the cylindrical escapement (fig. 22) enables the constructor to dispense with the fusee.

It will, of course, be understood, that in such arrangements, while the wheel *c* is attached to the barrel, and by it to the external extremity of the mainspring, the ratchet-wheel *B* is attached to the axle *T B* (fig. 17), and by it to the internal extremity of the mainspring.

When a fusee is used, the ratchet-wheel being fixed upon its axis, and not on that of the barrel containing the mainspring, this method of obtaining a maintaining power is not applicable. In such cases, the object is attained by two ratchet-wheels upon the axle of the fusee, having their teeth and catches turned in opposite directions, one of them being impelled by a provisional spring, which only comes into play when the action of the mainspring is suspended during the process of winding up.

The fusee, with its appendages, as commonly constructed, without a maintaining power, is drawn in fig. 29, the grooved cone, with the ratchet-wheel attached to its base, being raised

Fig. 29.

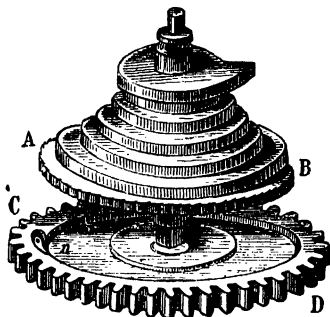

from the cavity in the toothed wheel *c D*, in which it is deposited, to show the arrangement more clearly, and in the edge of which the catch *n* is placed, so that it shall fall into the teeth of the ratchet-wheel.

When the watch is being wound up, the chain passing from the barrel to the grooves of the fusee, the teeth of the ratchet-wheel, *A B*, pass freely round the cavity, the catch *n* falling

from tooth to tooth, and producing the clicking noise already noticed. But when the watch is going, the tension of the chain draws the fusee and the ratchet-wheel attached to it round in the contrary direction, and, pressing the teeth of the ratchet-wheel against the catch *n*, carries round the wheel *c D*, which gives motion to all the other wheels, and through them to the hands. Now, it will be evident, that when the watch is being wound up, and the catch *n* relieved from the pressure of the teeth of the ratchet-wheel, no motion will be imparted to *c D*, and consequently the movement of the entire works will be suspended.

The modification by which a maintaining power is obtained by the combination of two contrary ratchet-wheels, is shown in

## MAINTAINING POWER OF A WATCH.

fig. 30, where *c d* is the first wheel of the train from which the watch receives its motion. The ratchet-wheel *A* is fixed upon the base of the fusee, so as to move with it. The catch,

Fig. 30.

*m*, which is pressed by a spring into the teeth of this ratchet-wheel, is attached to the second ratchet-wheel *B*, so that when *A* is carried round by the chain acting on the fusee, it must carry the wheel *B* round with it in the direction of the arrow *f*. The wheel *B* is connected with the wheel *c d* by a semicircular spring *a b c*,

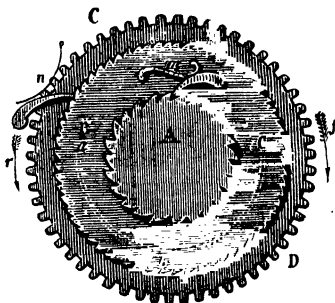

which is attached to the wheel *c d* at *c*, and to the wheel *B* at *a*. The catch, *n*, which falls into the teeth of the ratchet-wheel *B*, is attached to a fixed point on the bed of the watch.

While the watch is going, the wheel *B*, driven by the fusee, draws after it the spring *a b c*, bending it round to a certain extent, and this spring acting at *c*, on the wheel *c d*, draws it round in the direction of the arrow *f*. Now, let us suppose that the watch is being wound up. The ratchet-wheel *A*, being turned by the key in the direction of the arrow *r*, the catch *m* falls from tooth to tooth, and the force it before received from the ratchet-wheel *A* is suspended. But the spring *a b c* has been drawn from its form of equilibrium, to a certain small extent, in drawing round after it the wheel *c d*, as already stated, and it has still a tendency to draw that wheel after it, so as to recover its form of equilibrium. In doing this, it will continue to act upon the wheel *c d*, and to carry it round while the action of the fusee upon it is suspended during the process of being wound up. The spring *a b c* is so constructed as to act thus for an interval more than is necessary to wind up the watch.

46. From what has been explained, it will be observed, that timepieces in general are constructed with one or other of two moving powers, a descending weight, or a mainspring, and with one or other of two regulators, a pendulum or a balance-wheel. These expedients are variously adopted and variously combined, according to the position and circumstances in which the time-piece is used, and the purpose to which it is appropriated.

A descending weight as a moving power, combined with a pendulum as a regulator, supply the best chronometrical conditions. But the weight can only be used where a sufficient vertical space

## COMMON THINGS—CLOCKS AND WATCHES.

can be commanded for its ascent and descent, and neither it nor the pendulum is applicable except to timepieces which rest in a fixed and stable position.

In the case of timepieces whose position is fixed, but where the vertical space for the play of the weight cannot be conveniently obtained, the mainspring is applied as a moving power, combined with the pendulum as a regulator. Chimney and table clocks present examples of this arrangement. The height being limited, it is necessary also in these cases to apply short pendulums. The length of a pendulum which vibrates seconds being about 39 inches, such pendulums can only be used where considerable height can be commanded.

It has been shown, that the lengths of pendulums are in the proportions of the squares of the times of their vibration. It follows, therefore, that the length of a pendulum which would vibrate in half a second, will be one-fourth the length of one which vibrates in a second, and since the latter is 39 inches, the former must be  $9\frac{3}{4}$  inches. Such a pendulum can therefore be conveniently enough applied to a chimney or a table clock high enough to leave about ten inches for its play.

The pendulum is so good a regulator, and the anchor-escapement renders it so independent of the variation of the moving power, that in timepieces where it is combined with a mainspring a fusee is found to be unnecessary. In such cases, therefore, the axis of the first wheel is placed in the centre of the mainspring, as represented in fig. 17.

47. The cylindrical escapement, shown in fig. 22, is nearly as independent of the variation of the moving power as the pendulum, and therefore in common watches, where this escapement is used, the fusee is dispensed with.

In the class of timepieces called chronometers, used for the purposes of navigation, and in general for all purposes where the greatest attainable perfection is required in a portable timepiece, all the expedients to insure regularity are united, and accordingly the detached escapement is combined with fusee and mainspring.

Besides the expedients above mentioned, for insuring uniformity of rate, provisions are made in the most perfect chronometers to prevent the variations of rate which would arise from the expansion and contraction of the metal composing the balance-wheel by the variation of temperature. These expedients are very various; but in general they consist of contrivances by which the expansion of the rim of the wheel causes a part of it so to bend, as to throw a heavier part nearer to the centre, to compensate for the increased distance of another part produced by its general enlargement.

## MARINE CHRONOMETER.

48. Marine chronometers are usually suspended in a box on gimbals, like those which support the ship's compass. The balance-wheel usually vibrates in half seconds, being a much slower rate than that of common watches. They are of immense utility in navigation, and especially in long voyages. See Tract on "Latitudes and Longitudes," Museum, vol. i. p. 97.

49. In observatories where stationary timepieces can be used, the clock moved by weights and regulated by a pendulum is invariably adopted. The pendulum, in such cases, is always so constructed that its rate of vibration shall not be affected by variations of temperature. This is accomplished usually by constructing it of two different kinds of metal, which are differently affected by heat, one being more expansible than the other. They are so arranged that the expansion of one shall elevate the centre of gravity, while that of the other lowers it, and the two effects are made to compensate each other, so that, however the temperature may change, the rate of vibration will remain the same.

50. In clocks adapted for domestic and public use, it is found desirable that they should give notice of the time, not only to the eye, but to the ear; and for that purpose a bell is attached to them, which tolls at given intervals, the number of strokes being equal to that of the units in the number expressing the hour. This appendage is called the STRIKING TRAIN.

The striking train, though connected with that which moves the hands, is quite independent of it, having its own moving and regulating power, and its own system of wheels by which the effect of the moving power is submitted to the regulator, and transmitted to the tongue of the bell. •

Unlike the train which moves the hands, the striking train is not in continual motion. Its motion is always suspended, except at the particular moment at which the clock strikes. The mechanism partakes of the character of an alarm, being stopped by a certain catch until the hands point to some certain hour, and then being set free by the withdrawal of the catch. It remains free, however, only so long as is necessary for the tongue or hammer to make the necessary number of strokes upon the bell, after which the catch again engages itself in the striking mechanism, and stops it.

Some clocks only strike the hour. Others mark the half hours, and others the quarters, by a single stroke.

The general principle of the striking mechanism will be rendered intelligible by fig. 31, which represents it in the case of a common clock moved by a weight.

The weight suspended from the cord E moves the train in the same manner as in the case of the train which moves the hands. The motion of the first wheel, C, is transmitted to the last wheel, I,



COMMON THINGS—CLOCKS AND WATCHES.

which corresponds to the escapement-wheel by the intermediate wheels and pinions, *f*, *F*, *g*, *G*, *h*, *H*, and *i*. The wheel *i* drives

Fig. 31.

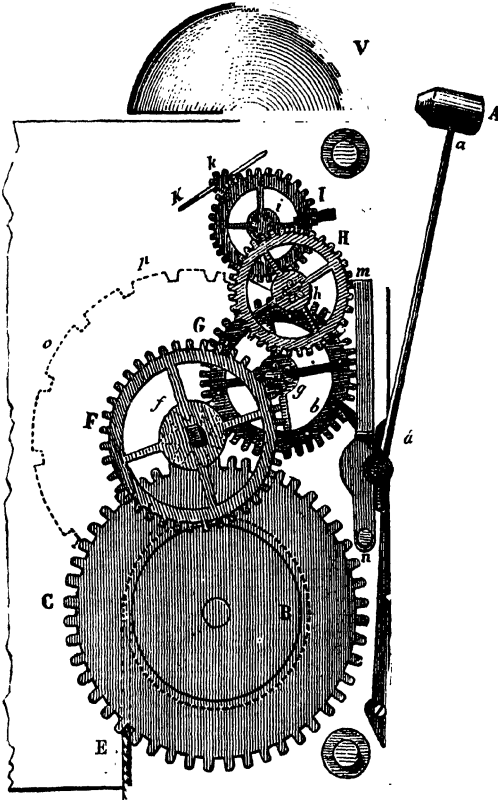

the pinion *k*, upon the axle of which is fixed the regulator  $\kappa$ . This regulator is a fly, a side view of which, upon a larger scale, is shown in fig. 32.

The pinion, which is made to revolve by the wheel *w*, gives a motion of rotation to the fly *AA'B'B*, which consists of a thin rectangular plate of metal, along the centre of which the prolongation *ML* of the axle of the pinion is attached. The flat surfaces of the fly, revolving more or less rapidly, strike against

## STRIKING APPARATUS.

the air, which resists them with a force which increases in the proportion of the square of the velocity of the rotation. Thus, if the velocity of rotation be increased in a two-fold ratio, the resistance to  $AA' B'B$  is increased in a four-fold ratio; if the rotation be increased in a three-fold ratio, the resistance is increased in a nine-fold ratio, and so on. It is evident, therefore, that by this very rapid increase, the resistance to the motion of the train must soon become equal to the descending force of the weight, and then the motion will become

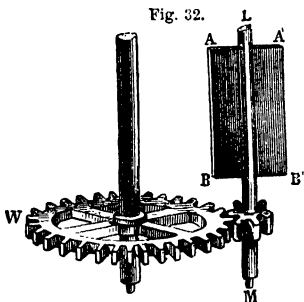

uniform; for if it were to increase, the resistance would exceed the force of the weight, and would slacken the rate of motion; and if it were to decrease, the resistance being less than the force of the weight, the latter would accelerate the motion. In either case the motion would immediately be rendered uniform.

Projecting from the face of the wheel  $\pi$  (fig. 31) there is a small pin which rests upon the end  $m$  of a lever  $m n$ , which turns upon the centre  $n$ . The lever  $m n$  when in this position stops the motion of the striking train. Behind the same lever  $m n$ , and projecting from it, there is another piece, which in the position represented in the figure rests in a notch of the wheel  $o p$ , lying behind the striking train, and indicated in the figure by dotted lines. Around the edge of this wheel there is a series of similar notches at unequal distances, determined in the manner which we shall presently explain.

Upon the face of the wheel  $g$ , at equal distances one from another surrounding it, a series of pins project, which, as the wheel turns, successively encounter a lever  $b$ , which plays upon a centre  $a$ . Upon the same centre  $a$  is fixed the handle  $a a'$  of the hammer  $A$  by which the bell  $v$  is struck. A spring fixed upon the same centre  $a$  causes the lever  $b$  to rest in the position represented in the figure, and to return to that position if raised from it. The hammer handle  $a a'$  is made either elastic itself or is provided with a like spring.

When the wheel  $g$  is made to revolve at a uniform rate by the weight  $E$ , regulated by the fly  $K$ , the pins projecting from the face of the wheel  $g$  encounter successively the lever  $b$ , and raising it, throw back the handle  $a a'$  of the hammer which is in connection with the lever  $b$ . After the pin has passed the lever  $b$  the latter is brought back with a jerk by the action of the spring, and the

## COMMON THINGS—CLOCKS AND WATCHES.

hammer *A* receiving the same jerk strikes upon the bell *v* and instantly recoils from it; and if the wheel *G* continues to revolve, one pin after another upon it will encounter the lever *b*, and the hammer *A* will make a stroke upon the bell each time that a pin passes the lever.

The wheel *H* is so constructed that it will make one revolution in the interval between two successive strokes of the bell, or what is the same, in the interval between the moments at which two successive pins pass the lever *b*.

In the train which moves the hands, an expedient is provided by which each time that the minute hand passes twelve upon the dial, the lever *m n* is thrown back from the position which it has in fig. 31, and the top *m* being withdrawn from under the pin upon the wheel *H*, that wheel and the entire striking train is liberated and set in motion. At the same time the piece is taken out of the notch in which it rested on the wheel *o p*, and that wheel, in common with the other parts of the striking train, is put in motion.

For every complete revolution that the wheel *H* makes, the hammer *A* makes a stroke upon the bell, and the motion of *H* and of the entire striking train will continue until the end *m* of the lever *m n* again comes under the pin projecting from the face of *H*. During the motion, the lever *m n* is kept back by the edge of the wheel *o p* acting against the piece projecting from the lever *m n*. But when the wheel *o p* has turned so as to bring the next notch to the projecting piece, it will be thrown into the notch, and the end *m* of the lever *m n* coming under the pin projecting from the wheel *H*, the motion of the train will be suspended.

Now, it will be evident from what has been stated, that when the lever *m n* is thrown back by the works, it is kept back by the edge of the wheel *o p* acting against the projecting piece, and so long as it is thus kept back, the striking train continues to move and the hammer continues to strike the bell. But the duration of this motion will depend on the space between the notches on the wheel *o p*, since it is while that space upon the edge passes under the projecting piece on *m n* that the end *m* of the lever *m n* is kept back so as to be out of the way of the pin projecting from the wheel *H*. These spaces between the notches are therefore so proportioned, one to another, that the lever *m n* at each hour is held back a sufficient time for the hammer to make upon the bell the number of strokes denoting the hour and no more.

The arrangement for striking half-hours and quarters is based upon similar principles.

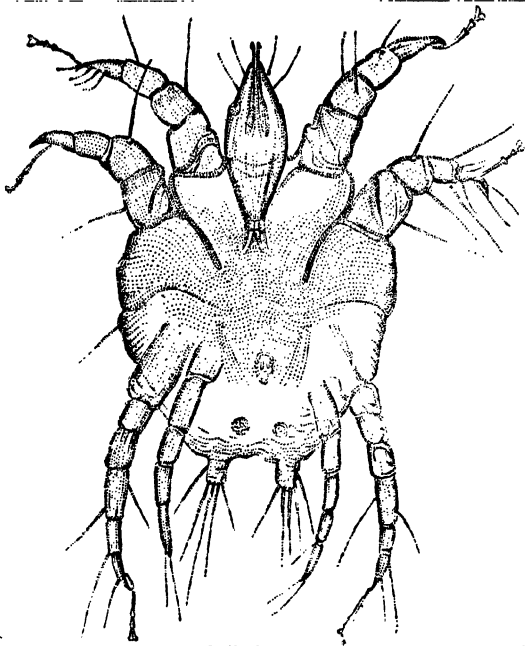

Fig. 37.—VIEW OF THE MANGE INSECT OF THE HORSE, MAGNIFIED 150 TIMES IN ITS LINEAR AND THEREFORE 22500 TIMES IN ITS SUPERFICIAL DIMENSIONS.

## MICROSCOPIC DRAWING & ENGRAVING.

### CHAPTER I.

1. Beautiful precision of the minute structure of natural objects.—2. Cornea of a fly's eye.—3. Number of eyes of different insects.—4. Astonishing precision of artificial objects.—5. Demand for such objects by Microscopists.—6. Classes of such artificial objects.—7. Microscopic scales.—8. Method of engraving them.—9. Measurement of microscopic objects with them.—10. Their minuteness.—11. Scales

## MICROSCOPIC DRAWING AND ENGRAVING.

of Mr. Froment.—12. Rectangular scales.—13. Micrometric threads.—14. Necessity for microscopic tests.—15. Test-objects.—16. Telescopic tests; double stars.—17. Nebulæ and stellar-clusters.—18. Effects of different telescopes upon them: telescopes of Herschel and Lord Rosse.—19. Remarkable nebulæ described by Herschel.—20. Differently seen by Lord Rosse.—21. Microscopic tests.—22. Improved powers of microscope.—23. The *Lepisma-Saccharina*.—24. The Podura, or Spring-tail.

1. No person can witness without the highest degree of admiration the spectacle presented by certain parts of the structure of the more minute members of the animal kingdom, when viewed with a powerful microscope. The absolute geometrical precision and extreme beauty of design shown in such objects, are truly remarkable. We will not say, that such perfection of workmanship discovered in these minute objects, which must have for ever escaped the human eye without the intervention of scientific aid, ought to excite surprise, because no result, however perfect, of infinite power combined with infinite skill should raise that sentiment. Nevertheless, it must be admitted, as a matter of fact, that the contemplation of such objects is generally attended with a sense of wonder, approaching to awe, a striking proof how few they are that have sufficiently familiarised their minds with the ideas of omnipotence and omniscience.

2. Innumerable examples of the perfect precision of structure, adaptation and design, combined with a minuteness, which not only far surpasses the limits of the senses, but severely taxes the imagination, are presented in the organisation of natural objects. The membrane, which in the eyes of certain species of insects corresponds to the cornea of the human eye, presents an example of this. A very exact notion of this membrane, as it exists in the eye of the common house-fly, may be obtained by stretching a piece of bobbin-net over the surface of a billiard-ball: the ball with its reticulated hexagonal coating will then be a very precise model of part of the eye of the insect, upon a prodigiously magnified scale.

We have given in fig. 1 an engraving of this membrane, taken from a microscopic drawing, magnified 100 times in its linear, and therefore 10000 times in its superficial dimensions.

3. Each hexagon, as shown in the figure, is the cornea of a separate eye, having behind it the proper optical apparatus to produce the sense of vision. But it is more particularly to the minuteness of these beautifully precise hexagonal eyes, that I desire at present to direct attention. That minuteness will be most strikingly manifested by stating the number of these eyes with which different classes of insects are provided. According to the observations of various eminent naturalists, such as Swammerdam,

## INSECTS' EYES.

Leuwenhoeck, Barter, Reaumur, Lyonnet, Paget, Müller, Straus

Fig. 1.

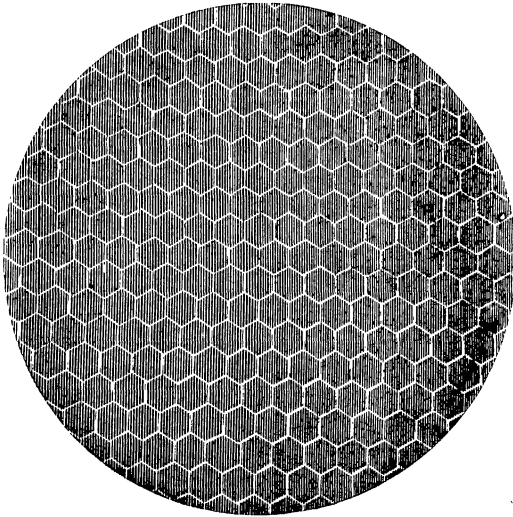

Dugès, Kirby, &c., the following are the number of eyes in certain species :—

Number of eyes.		Number of eyes. ●	
The Ant and the Zenos	50	The Cosus Ligniperda	11300
The Sphinx	1300	The Dragon Fly	12544
The common Fly	4000	The Butterfly	17355
The Silkworm	6236	The Mordella	25088
The Cockchaffer	8820		

4. But if the perfection found in the most minute workmanship of nature excite our admiration, how much more must we admire and wonder at the approaches which have been made to a similar degree of precision and perfection by the comparatively feeble and imperfect agency of the human hand. We propose in the present article to call the attention of our readers to some striking examples of such skill and address, with which the general public is not already familiar.

5. The improvements which have been made within the last quarter of a century, in the construction of microscopes, has created a demand for a class of drawings and engravings of a degree of minuteness approaching to that of the objects to which the researches of observers have been addressed. This

## MICROSCOPIC DRAWING AND ENGRAVING.

demand of Science upon Art has been adequately and admirably responded to.

6. Mechanism has been invented, by which minute tracings are made by a diamond point on the surface of glass; such tracings being adapted to serve three distinct purposes:—1st. As standard measures of microscopic objects by superposition on them, just as ordinary lengths and breadths are determined by the application of the standard measure of yards, feet, and inches; 2ndly, To serve as tests of the degree of excellence attained in the construction of microscopes, and as means of comparing the relative excellence of different microscopes, by observing the degrees of distinctness with which they enable the observer to see such minute tracings; and, 3rdly, to serve for the production of microscopic engravings on its proper scale of any desired design.

This last process cannot be said to have been applied hitherto to any useful purpose other than the exhibition of an artistic *tour de force*, being, so far as relates to its means of execution, by far more difficult and ingenious than either of the former.

7. Microscopic objects are measured by divided scales of known dimensions; their lengths and breadths being ascertained by the number of divisions of the scales on which they are placed, included between their limits or within their contour. Such scales, like larger measures, vary with the magnitude of the objects to which they are to be applied, but, even when largest in their divisions, are still very minute. They are generally traced upon small oblong slips of glass, the divisions being marked by fine parallel lines, every fifth division being a little longer than the intermediate ones, and every tenth still longer, as is shown on a greatly magnified scale in fig. 2.

Fig 2.

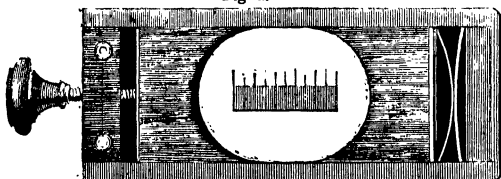

8. The slip of glass upon which the scale is engraved is usually set in a brass framing, in which it is capable of sliding longitudinally, being pressed forwards in one direction by a fine screw, and in the other direction by the action of springs.

The diamond point by which the divisions are traced, is urged upon the glass, with a regulated pressure, so as to make traces so

## MICROMETRIC SCALES.

even and uniform that no irregularity in their edges is discoverable by any microscopic power to which they are submitted. In the process of tracing the divisions, the point is moved over the glass, the latter being fixed, or the glass moved under the point by means of a very fine screw, called a micrometer screw, the magnitude of the thread of which is exactly known. The head of this screw is a metallic disc, fig. 3; the circumference of which is divided into from 200 to 400 equal parts, or even into a still greater number.

Let us suppose, then, the screw to be so fine that there are 50 threads to an inch, and the circumference of its head is divided into 100 parts; one revolution of the head will therefore move the screw and the diamond point upon which it acts through the one-fiftieth part of an inch. But if a fixed index be directed to the circumference of the head, so that the motion of the head through one division can be observed, such motion will move the diamond point through the 1-5000th of an inch.

The cutter, after tracing each division, is raised from the glass, while the diamond point is pushed forward by the screw to the position necessary to engrave the next division of the scale, and proper mechanism limits the motion of the screw, so as to regulate the relative lengths of the divisions of the scale in the manner already explained.

9. A scale thus engraved, being viewed with a microscope whose magnifying power is proportionate to its minuteness, the divisions are rendered as distinctly visible as those of an ordinary rule are to the naked eye, and if the object to be measured be laid upon the glass its dimensions may be ascertained, as those of an object of ordinary size would be by a common rule.

10. These scales vary in the magnitude of their divisions, according to the magnitude of the objects which they are intended to measure. On those which have the largest divisions, an inch is divided into 500 parts; scales, however, are furnished by the opticians for microscopes in which an inch is divided into 2500 parts.

11. However minute such scales may seem, they are by no means the most minute that have been executed. Mr. Froment, whose apparatus for the division of astronomical instruments is well known, has supplied me with a scale in which a millimètre is divided into 1000 equal parts. Each division of this scale is, therefore, only the 1-2500th part of an inch.

Fig. 3.

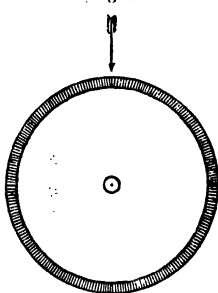



## MICROSCOPIC DRAWING AND ENGRAVING.

12. Scales are sometimes engraved so as to indicate at once the dimensions of an object in length and breadth, by lines dividing

Fig. 4.

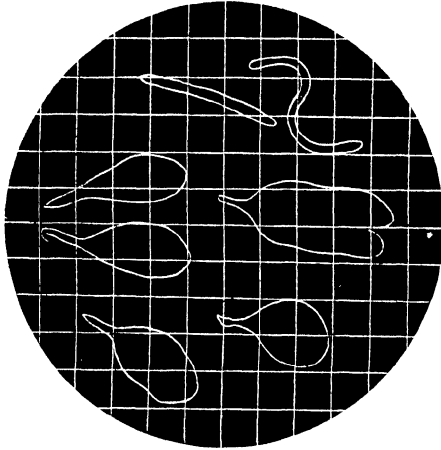

the glass in directions at right angles one to the other, as shown in fig. 4, upon a greatly magnified scale.

13. The dimensions of a minute object are sometimes ascertained by a somewhat different expedient.

Fig. 5.



Let two lines,  $a a'$  and  $b b'$ , fig. 5, intersecting at right angles, be engraved upon a slip of glass, which can be inserted into the tube of a microscope, as shown in figures 6 and 7, through an opening in the side, which can be closed when such measurement is not required. These engraved lines, when the microscope is properly adjusted, will be seen like two fine threads pro-

jected on the object, as shown in fig. 5.

Arrangements are made by which, while the object is fixed,

## USE OF TESTS.

the glass upon which the lines  $a a'$  and  $b b'$  are engraved, can be moved by a fine micrometer screw until the line  $b b'$  shall pass

Fig. 6.

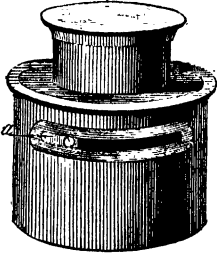
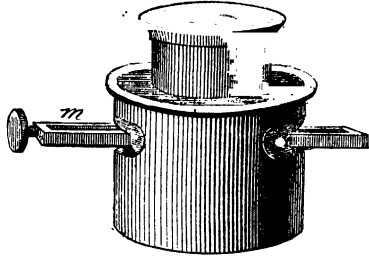

Fig. 7.



successively through the two extremities of the object, or the same purpose will be served, if, while the glass remains at rest, the stage which supports the object be similarly moved.

The number of threads of the screw to an inch being known, the number of revolutions and parts of revolutions of the screw necessary to make the line pass from one extremity to another, will give the length of the object, and a like process will determine its breadth.

In the application of such scales to microscopic measurements, various practical precautions and expedients are necessary, which will be fully explained in our Tract on the Microscope.

14. Independently of being provided with means such as have been described above, for ascertaining the dimensions of objects, the advanced state of science renders it indispensable that the observer should possess means of testing the power of his instrument; without such means, he can never be sure that the appearance of the object, as presented by his microscope, corresponds with its real structure, or that important details of that structure may not escape his observation. A more striking example of this cannot be presented than one which was given by the late Dr. Goring, who showed that a particle of the dust taken from the wing of a certain species of butterfly, called the *Morpho Menelaus*, exhibited the seven different appearances shown in fig. 8; when viewed with the same microscope, the aperture of the object-glass and, consequently, the brightness of the image only being varied. It will be seen that details of structure are rendered apparent in  $G$ , where the aperture is greatest, which are very imperfectly shown in  $F$ , and not at all in those in which the aperture was still more limited.

## MICROSCOPIC DRAWING AND ENGRAVING.

If, therefore, the observer were only supplied with a microscope, such as would have shown the object as exhibited at D, he would evidently have formed a very incorrect notion of its structure; and it is accordingly found, that every improvement which has taken place has disclosed to us a new order of natural facts.

Fig. 8.



In order, therefore, to put the observer in a position to ascertain how far he can rely upon the indications of his instrument, it is necessary to supply him with some objects of known structure, whose details the instrument ought to make visible if it have the power which it claims.

15. Such objects, which have proved to be eminently useful in microscopic researches, and highly conducive to the progress of science, are called **TEST-OBJECTS**.

16. In the case of the telescope applied to astronomical researches, similar tests of efficiency are found in countless numbers in the heavens. Double, triple, and multiple stars are the most obvious examples of these. Such objects, as is well known, appear when viewed with the naked eye, or even with ordinary telescopes, as single stars; but when instruments of superior power are directed to them they are **RESOLVED**, as it is called, and seen as what in fact they are, two or more minute stellar points in such close proximity, that the space between them is too small to affect the eye in a sensible manner, unless when magnified by artificial means.

17. Nebulæ supply another order of telescopic test-objects. These appear, even when viewed with telescopes of considerable power, as small patches of whitish, cloudy light, of greater or less magnitude, a character from which they have received their name.

Such an object is represented, for example, in fig. 9.

When, however, a telescope of higher power is directed upon the same object, it will assume such an appearance as is shown

## TELESCOPIC TESTS—NEBULÆ.

in fig. 10, a faint and rather indistinct indication of minute stars being perceptible; but when a still higher power is brought to bear upon it, the object will be seen as what it really is, a dense mass consisting of countless numbers of separate stars, as shown in fig. 11.

18. Different nebulæ require telescopes of different powers, and many have never been yet resolved, even by the greatest powers that scientific art has yet produced. In proportion, however, as the telescopic power has been increased, more and more of these objects have been resolved. A remarkable illustration of this state of progressive discovery is supplied in the case of a well-known nebula, first observed and drawn by Sir John Herschel, as seen in a twenty-foot reflector. Sir John

Fig. 10.

Fig. 9.

Fig. 11.

describes it as an object shaped like a dumb-bell, double-headed shot, or hour-glass; the elliptic outline being filled up by a more feeble and nebulous light, as shown in fig. 12, copied from the drawing of Sir John Herschel.

Such was the form and character assigned to this object until Lord Rosse had constructed larger and more powerful instruments, and when he directed upon it a twenty-seven foot reflector with three feet aperture, it assumed the appearance shown in fig. 13, where a faint indication of stars can be seen; subsequently,

## MICROSCOPIC DRAWING AND ENGRAVING.

however, when he examined the same object with his great fifty-three foot telescope, having six feet aperture, it assumed the appearance shown in fig. 14.

19. Another very remarkable example of the change of appear-

Fig. 14.

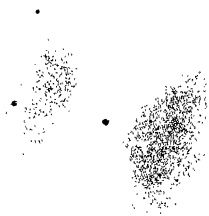

ance produced in one of these wonderful objects, is presented in the case of a nebula first observed by Sir Wm. Herschel, and

Fig. 13.



described by him as a bright round nebula, surrounded by a halo or glory, and attended by a much smaller companion. Sir John

## TELESCOPIC TESTS—NEBULÆ.

Herschel observed the same object, and discovered in it a very remarkable feature, which the telescope of his father had failed to disclose. This object, as drawn by Sir John Herschel, is shown in fig. 15. The separation in what Sir William Herschel called a

Fig. 14.



halo or glory, and what Sir John Herschel calls a ring, was the remarkable character which Sir John discovered. Sir John conjectured, from the general appearance of the object, that the central round nebula is a globular mass of stars, too distant to admit of being resolved by his telescope, and that what his father called a glory, is an annular mass of stars surrounding the former and split in the direction of its plane, so as to produce the appearance shown in the upper part of the figure.

Sir John conjectured that such stellar masses might have some analogy to the mass of stars which forms the milky way, and of which our sun is an individual unit.

20. How completely these speculations, ingenious as they were, were scattered to the winds, by bringing to bear on the same object a higher telescopic power, will be apparent by inspecting

## MICROSCOPIC DRAWING AND ENGRAVING.

fig. 16, in which the same object is shown as it was afterwards seen with the great telescope of Lord Rosse.

Lord Rosse thinks that the brilliant convolutions of the spiral shown in his telescope, are identical with the split or divided part

Fig. 15.

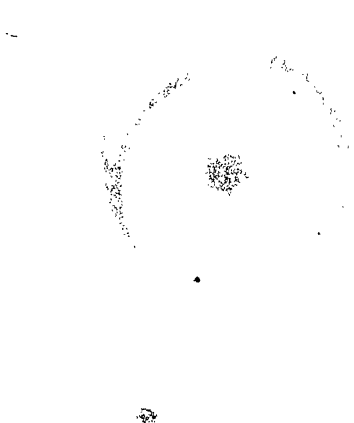

of the ring as seen by Sir John Herschel, and he further observes, that with each increase of optical power, the structure of this object becomes more complicated and more unlike anything which could be supposed to result from any form of dynamical law of which we find a counter-part in our own system.

Before dismissing this very interesting subject of telescopic tests, we shall indicate one other, scarcely less remarkable. In fig. 17, is shown a small annular nebula, of a slightly oval form, observed and drawn by Sir John Herschel; the dark space in the centre of the ring he described to be filled with nebulous light, and that the edges were not sharply cut off, but were ill-defined, and exhibited a curdled and confused appearance, like that of a star seen with a telescope out of focus.

## MICROSCOPIC TESTS.

The same object as seen with the more powerful telescope of Lord Rosse, is shown in fig. 18.

It is evident from this that very little more increase of optical

Fig. 16.

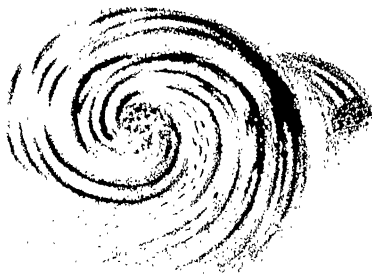

power would resolve this extraordinary object into an annular mass of stars.

21. Seeing then that the stupendous works of creation, existing in regions of space at measureless distances from the earth, have supplied such an unlimited variety of telescopic test-objects, it was natural to seek in other parts of creation where the more minute workmanship of nature has play for a corresponding series of microscopic test-objects. At the moment when that great and rapid improvement in microscopes was commencing, which was so powerfully promoted by the scientific and practical skill of the late Dr. Goring and Mr. Andrew Pritchard, it was found that various minute parts of the structure of certain species of insects could be rendered distinctly visible only by instruments possessing certain degrees of optical efficiency.

Dr. Goring, accordingly, selected a certain number of these objects, which he arranged in a graduated series, according to the microscopic powers required to render distinctly visible the details of their structure. These objects consisted chiefly of minute scales, detached from the bodies and wings of certain species of

Fig. 17.





## MICROSCOPIC DRAWING AND ENGRAVING.

insects; the striæ and dots upon which could be seen with more or less distinctness, according to the excellence of the instrument.

Fig. 18.



It was to these that the name *test-objects* was first applied.

22. As the microscope has been improved in its power from year to year, these test-objects have increased in number; new details of structure being developed by every increase of power and efficiency in the instrument. A certain list of such objects has been agreed upon by general consent, and prepared for sale by the makers, consisting of hairs, scales, and feathers of insects; as, however, it is not my present purpose to enter into any explanation on the subject of microscopic tests, except so far as may be necessary to elucidate one of the uses of microscopic engraving, it will be

sufficient here to give a few examples of these test-objects.

23. There is a little insect, vulgarly called the *silver-fish*, or the *silver-lady*, of which the proper entomological name is the *Lepisma-Saccharina*; it is usually found in damp and mouldy cupboards, and in old wood-work, such as window-frames. The silvery lustre from which it takes its vulgar name, proceeds from a coating of scale-armour, with which its entire body is invested. These scales, when detached from the insect, and examined with a microscope, present a beautiful striated appearance; their magnitude varies; one, whose length is the 114th, and width the 170th part of an inch, is shown in fig. 19, as it appears in a good microscope, magnified 400 times in its linear, and therefore 160000 times in its superficial dimensions.

The scale, as here shown, is divided along the middle of its breadth, by a sort of geometrical axis, on either side of which the structure is perfectly similar. A regular series of striated lines diverge from this axis, at an angle of about  $45^\circ$ , intersected by another series, very nearly parallel to the axis.

The divergent striæ are very slightly curved; the concavity being presented downwards, and the longitudinal ones ought to appear with a microscope to stand out in bold relief, like the ribs seen on certain shells; they are more closely arranged as they approach the lower part of the scale, and become more prominent as they are more separated in proceeding upwards.

## LEPISMA AND PODURA.

Although the *Lepisma* is usually ranked among the test-objects it must be observed that it is one of the lowest order, an instrument

Fig. 19.

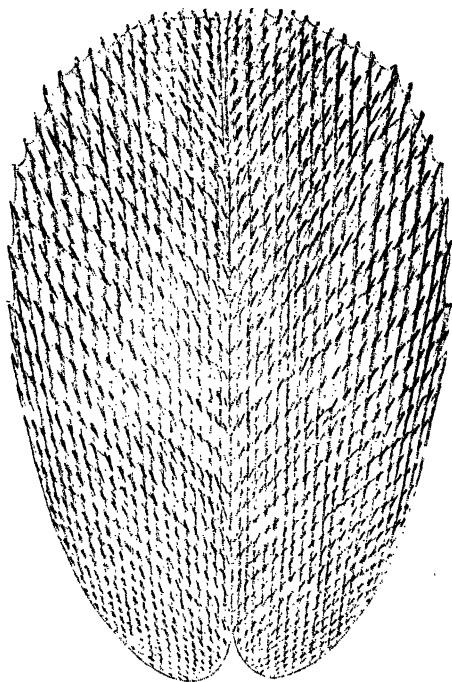

of the most moderate efficiency never failing to render the striae tolerably distinct.

24. The *Podura*, or common Spring-tail, is a little insect, generally found in great numbers in damp cellars, where they may be seen, running and skipping about upon the walls. Mr. Pritchard recommends the following method of collecting them: Sprinkle a little oat-meal or flour upon a piece of blackened paper, and place

## MICROSCOPIC DRAWING AND ENGRAVING.

it near their haunts; the meal serving the purpose of a bait, they will soon collect upon it; the paper may then be removed, and

Fig. 20.



being placed in a basin, should be brought into the light, when the insects will immediately jump from the paper into the basin: they should then be cautiously handled, and placed either in glass tubes or boxes with camphor, to preserve them from other insects.

These insects, like the *Lepisma*, are covered with an armour of scales, which, when submitted to the microscope, are found to be beautifully striated; one of them is shown in fig. 20, magnified 550 times in its linear, and, consequently, 302500 times in its superficial dimensions. The real length of this scale was the 260th, and its extreme breadth the 700th, part of an inch.

Smaller, and still more finely marked, scales of the same insect are shown in fig. 21; the length of the greater being the 250th, and its breadth the 500th, of an inch; and the length of the lesser the 700th, and its breadth the 1375th, of an inch.

These objects require much greater microscopic power to render visible their minute and beautiful tracery, than such as would suffice for the scale of the *Lepisma*, when submitted to the highest practicable magnifying powers; they are found to be marked by countless numbers of delicate cuneiform markings, which are seen to stand out in manifest relief from the general ground of the scale.

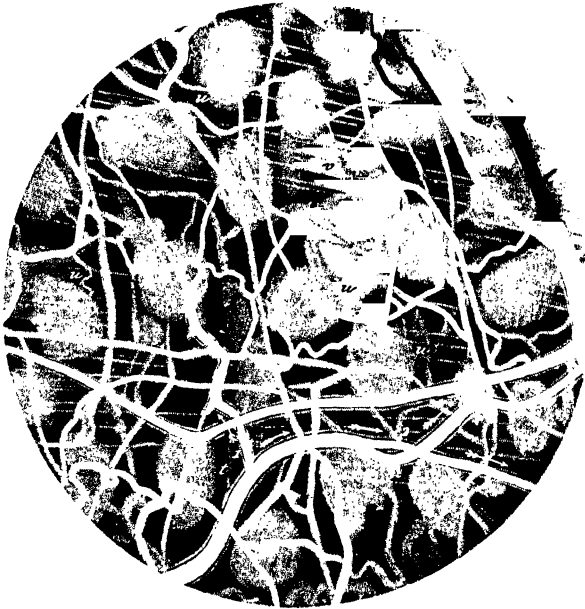

Fig. 39.—VIEW OF THE BLOOD-VESSELS AND OTHER PARTS IN A PORTION OF THE UPPER SURFACE OF THE TONGUE OF A FROG, THE REAL MAGNITUDE OF THE SURFACE DELINEATED BEING A CIRCLE THE 120TH OF AN INCH IN DIAMETER. DAGUERRE-TYPED BY MESSRS. DONNÉ AND FOUCAULT.

## MICROSCOPIC DRAWING & ENGRAVING.

### CHAPTER II.

25. Natural tests not invariable.—26. Natural tests imperfect standards.—27. Nobert's test-plates.—28. The degree of closeness of their lines.—29. Their use.—30. Apparent error respecting them.—31. Froment's microscopic engraving.—32. Method of executing it.—33. Various methods of microscopic drawing.—34. Drawings by squares.—35. Dr. Goring's drawings.—36. Structure and metamorphosis of insects.—37. The day-fly.—38. The larva of this insect.—39. Its organs of respiration.—40. Its general structure.—41. Its mobility.—42. State of chrysalis.—43. The perfect insect.—44. The production and deposition of its eggs, and its death.—45. Death may be delayed by postponing the laying of the eggs.—46. They take no food.—47. Their countless numbers; their bodies used as manure.

## MICROSCOPIC DRAWING AND ENGRAVING.

25. ALTHOUGH these, and numerous other objects selected from the minute parts of the animal kingdom, have been proposed, and generally adopted, as microscopic tests; they are subject to the obvious objection, that, when considered as standards, they are wanting in permanence and identity. Not only do the scales

Fig. 21.



taken from different individuals of the same species differ in the fineness and delicacy of their tracery, but striking differences are found between scale and scale, taken from the body of the same individual insect. Thus, for example, the scales shown in fig. 21, and that shown in fig. 20, were taken from the same *Podura*, yet fig. 21 requires a much more efficient instrument to develop its tracery than fig. 20.

In fig. 22 is exhibited a scale of the same *Lepisma* from which that represented in fig. 19 was taken; and which has been drawn with the same magnifying power. The tracings upon this are evidently much more minute than those on fig. 19, and are consequently shown with much less distinctness. It appears,

Fig. 22.

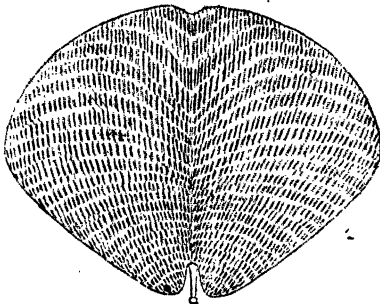

therefore, that these two scales, taken from the same individual insect constitute different microscopic standards.

## NOBERT'S TEST PLATES.

26. The erroneous estimates of the relative efficiency and power of different microscopic instruments which would result from the use of such test-objects, are obvious. A microscopist in London, observing the tracery of the scale of a Podura, and another at New York observing another scale of the same insect, the former failing to see its striæ, which would be visible to the latter, it could not at all be safely inferred, that the instrument of the one was inferior in efficiency and power to that of the other; and it might even happen, that the instrument which failed to show the striæ in London, was, nevertheless, superior to that which rendered them distinctly visible in New York. The result of such a comparison would entirely depend upon the structure of the two scales adopted as tests, which might differ within very wide limits.

Independently of this uncertainty attending the application of such tests, there is another not less serious objection to them; they hold out a temptation to microscope makers who supply them with the instruments they sell, to select such only as are most easily rendered visible; and although it be true that this is an expedient to which the most respectable class of makers would not resort, it is nevertheless true that the inferior makers do so, and thereby do injustice to those who are above such practices.

Natural objects, therefore, do not supply such permanent and unalterable tests for the microscope as the double stars, stellar clusters, and nebulæ do for the telescope; and this circumstance has directed the attention of the higher class of artists, to the production of artificial test-objects which shall have determinate and certain qualities, and which, like manufactured articles, may be reproduced with such absolute identity as to supply standards of comparison that can be applied in different places, and at different times, to different instruments, so as to give results which will admit of comparison.

27. The production of micrometer scales, by Mr. Froment, the divisions of which are separated by intervals so small as the 25000th of an inch, has been already mentioned.

Now the lines marking such divisions being in closer proximity than those of the tracings upon certain test-objects, it will be evident that artificial test-objects might be made by means similar to those by which such scales have been executed, and there can be little doubt that the great artistic skill which has succeeded in producing traces, separated by the small interval above named, could be pushed further, so as to produce striated surfaces, which would serve all the purposes of test-objects.

Mr. Nobert, of Griefswall, in Prussia, has taken up this problem of test-objects, and, without attempting, as it would appear, to engrave micrometric scales, which would require intervals of some

## MICROSCOPIC DRAWING AND ENGRAVING.

exact aliquot part of a standard unit of length, has, nevertheless, produced bands engraved by a diamond point on slips of glass, consisting of a greater or less number of parallel lines, separated by intervals of surprising minuteness.

Some remarkable specimens of the production of this eminent artist were presented at the Great Exhibition in Hyde Park, in 1851. They consisted of ten bands, each composed of a certain number of parallel lines; those in each band being closer together than those in the preceding one. In the following table, we have given in the second column the number of lines which would fill the breadth of an inch in each succeeding band in one of these specimens.

I. . . . .	11265
II. . . . .	13142
III. . . . .	15332
IV. . . . .	17873
V. . . . .	20853
VI. . . . .	24309
VII. . . . .	28433
VIII. . . . .	33153
IX. . . . .	38613
X. . . . .	49910

Thus it appears that, in this specimen, the closeness of the ruled bands varied from 11000 to 50000 to the inch.

These bands are ruled on glass in parallel directions, being separated band from band, by comparatively wide intervals, so that, if sufficiently magnified, they present such an appearance as is shown in fig. 24. The highest band being that in which the lines are most separated, and the lowest that in which they are closest.

It is very difficult to convey a correct idea of the real appearance of this system of engraved bands before it is magnified; let us suppose, however, that fig. 23 represents the real magnitude of the

Fig. 23.



slip of glass upon which the engraving is made, and that the white circle in the centre is the part of the glass across which the series of ten bands, shown in a magnified form in fig. 24, are drawn. The entire space occupied by all the ten bands

will then be less in width than the black line which is drawn across the white circle in fig. 23. It must not be imagined that the white circle in fig. 23 represents that shown in fig. 24, the latter corresponds with a minute circular space in the centre of fig. 23, not much greater in diameter than the breadth of the black line.

28. Various other test-plates have been engraved, and put in circulation by Mr. Nobert; I subjoin the analysis of one consisting

## CLOSENESS OF LINES.

Fig. 24.

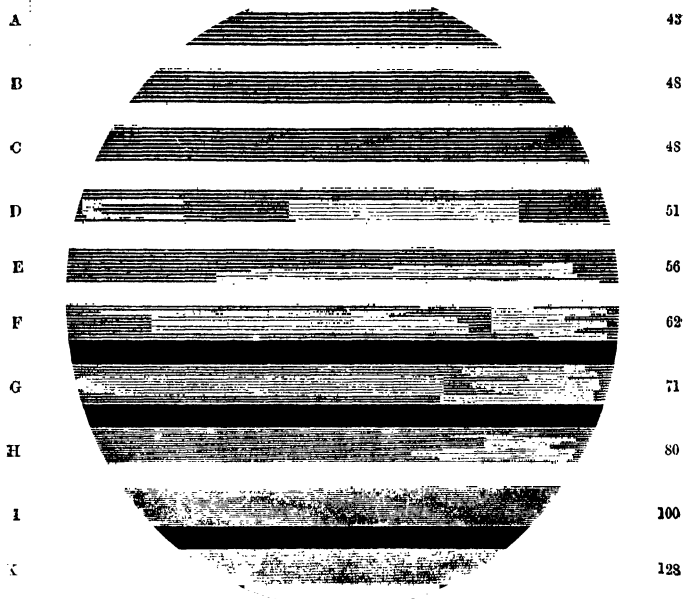

of 15 bands, which has been examined and calculated by Mr. De La Rue.

Series.	Number of lines.	Distance in relation to the English inch.	Number of lines in an English inch.
1	7	0·00008880	11261
2	8	0·00007548	13248
3	9	0·00006482	15427
4	10	0·00005506	18162
5	11	0·00004884	20475
6	13	0·00004262	23463
7	15	0·00003552	28153
8	17	0·00003108	32175
9	19	0·00002664	37537
10	21	0·00002442	40950
11	23	0·00002220	45045
12	24	0·00002113	47326
13	26	0·00001998	50050
14	27	0·00001891	52882
15	20	0·00001776	56306



## MICROSCOPIC DRAWING AND ENGRAVING.

I am informed by Mr. De La Rue, that bands engraved upon other plates, were observed and computed by himself, Mr. Lister, and Mr. Nobert, and the results now before me, are in such accordance as to leave no doubt of their general accuracy, the discrepancy being so trifling as to be explained by the small errors inevitable in such observations.

It will be evident that microscopes, having different degrees of power and efficiency, would be necessary to render the lines composing the successive bands of such a series distinctly visible; to determine what power would be required for each band, it is not at all necessary to have recourse to any microscopic observations; the question simply is, what is the degree of closeness of the lines, that the naked eye can barely distinguish as separate; this will, of course, be somewhat different for different eyes.

29. The use of these test-plates in determining the power and efficiency of microscopes, will be easily understood; instruments of low powers, such, for example, as from 100 to 200, will only make the wider bands, such as A B and c, fig. 24, distinctly visible, the closer ones, E F G, will be barely visible as dark bands, but the lines composing them will not be seen, and the closest of the series, H I K, will not be seen at all. In proportion as the power and efficiency of the microscope is increased, more and more of the bands will be visible as distinct series of lines.

Mr. Nobert supplies test-plates, engraved with bands of different degrees of closeness, according to the power of the instruments to which they are to be applied.

30. In the Report of the Juries of the Great Exhibition of 1851, page 268, it is stated, that to see the bands of a test-plate of 10 bands, such as that described above, a linear magnifying power of 100 is necessary for the wider bands, such as I and II, but that to distinguish those of the closest band, such as X, a magnifying power of 2000 is necessary.

I think it is apparent that this statement is erroneous; being evidently incompatible with the relative closeness of the lines of the several bands. Thus, for example, while there are 11265 lines of the first band to an inch, there are 49910 lines of the tenth band to an inch. Those of the latter are, therefore, only  $4\frac{1}{2}$  times closer than those of the former; and it is evident, that if these bands be viewed with two microscopes, one having a magnifying power  $4\frac{1}{2}$  times greater than that of the other, with proportional defining and illuminating powers, the lines composing them will appear equally separated; and since it is admitted in the report, that a power of 100 will render the lines of the first band visible, as it evidently will do, it will follow that

## NOBERT'S TEST PLATES.

a power of 450 will render the lines of the tenth band equally visible; indeed, it is not necessary at all to have recourse to the microscope to ascertain the effect which a given magnifying power ought to produce upon a band of a given degree of closeness, since it is evident that the effect must be merely to make the lines composing the bands more widely separated than they are in the exact proportion of the magnifying power. Thus, if the lines composing a band, separated by intervals of the 10000th part of an inch, be viewed with the magnifying power of 100, they will appear as those of a band separated by intervals of the 100th of an inch; and if it be viewed with a magnifying power of 1000, it will appear as if the lines were separated by the 10th of an inch, and so on.

Now, let us apply this obvious principle to the case given in the report of the Juries; a magnifying power of 100 directed upon the first band, would make the lines appear as if they were separated by intervals of the 112th part of an inch; those of the second band would appear separated by intervals of the 131st part of an inch, and those of the third by the 153rd part of an inch. Now, all these would, as admitted in the report, be distinctly seen as separate lines, by eyes of average power. But let us see what effect a magnifying power of 2000 would produce upon the closest of the bands.

Since it would render the apparent intervals between line and line 2000 times greater than they are, those between the lines of the tenth band, would be the 25th; those of the ninth, the 19th; and those of the eighth, the 17th part of an inch.

Although it must be quite evident that such intervals are much greater than is necessary to enable any eye whatever that can see at all, to perceive the lines distinctly separated, the reader will be enabled better to appreciate the point by referring to the numbers which we have placed on the right of fig. 24, which express severally the number of lines to an inch in each of the bands composing that figure; thus, the lines of the bands B and C are separated by intervals of the 48th part of an inch; and it follows, therefore, that a magnifying power directed upon the band X of the test-plate, mentioned in the report of the Juries, would, if viewed by a power of 2000, show the lines separated by intervals twice as great, or equal to those of every other line in the bands B and C, fig. 24.

For these reasons, it appears to me that a mistake has been committed in the report of the Juries in this point, and I have thought it the more desirable to call attention to it, inasmuch as the statement has been reproduced in several recent works upon the microscope.

It is easy to show what would be the degree of closeness of the

## MICROSCOPIC DRAWING AND ENGRAVING.

lines composing a band, which a power of 2000 would barely render visible to average eyes. Assuming that such eyes could see distinctly without microscopic aid the lines of a band consisting of 150 to an inch, it is evident that a power of 2000 would render equally visible those of a band, the lines of which would be 300000 to an inch. I am not aware that Mr. Nobert, or any other artist, has ever produced such lines, and consequently doubt the existence of any such artificial test for a power of 2000.

31. I now come to notice a sort of microscopic engraving, which, though it is at once the most curious and difficult, has not, so far as I am informed, had as yet any directly useful application. Regarded, however, as an example of mechanical ingenuity and skill, and as an artistic *tour de force* of the highest order, it is full of interest.

However much we may admire the production of the micrometric scales and microscopic test-plates described above, there is nothing in them to excite surprise, save the precision which is combined with such extreme minuteness. To draw a series of parallel lines of regulated length and uniform intervals, is a problem, to the solution of which it is easy to conceive that finely constructed mechanism can be adapted; but when it is proposed to delineate objects and characters, in which no such regularity prevails, and, in tracing which, the point of the graving tool must pursue a course determined by conditions, which obviously cannot be represented

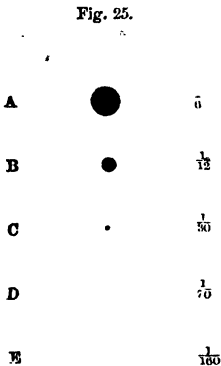

by any kind of mechanism, and to accomplish which it must be guided, directly or indirectly, by the hand, a problem of quite another, and far more difficult order, is presented: such, however, is the curious and complicated problem for which Mr. Froment, already named, has found a solution.

This eminent artist has succeeded in producing manuscripts and drawings, engraved upon glass, on a scale of minuteness in no degree less surprising, though far more difficult of execution than the test-plates of Mr. Nobert.

To enable the reader more easily to appreciate these wonderful productions, we have given in fig. 25 the forms and magnitudes of five small circular spaces, A, B, C, D, E, the diameters of which are severally the 6th, 12th, 30th, 70th, and 160th of an inch.

Mr. Froment wrote for me, in less than five minutes, within a

## FROMENT'S MICROSCOPIC WRITING.

circle of glass, the 40th of an inch in diameter, less, therefore, by one third than the small white spot c, fig. 25 ; the sentence which, when magnified in its linear, 120, and in its superficial dimensions, 14400 times, presented the appearance shown in fig. 26.

Fig. 26.

*Written*  
*as a microscopic object*  
*for Dr Lardner*  
*by Froment à Paris.*  
*1859.*

On the occasion of the Great Exhibition in 1851, the characters and figures shown in fig. 27 were engraved by Mr. Froment, within a circular space equal to that shown at c in fig. 25.

32. As the method by which these marvellous effects are produced is not yet patented or made public, we are not at liberty to explain its details ; but it may be stated generally to consist of a mechanism by which the point of the graver or style is guided by a system of levers, which are capable of imparting to it three motions in right lines which are reciprocally perpendicular, two of them being parallel, and the third at right angles to the surface on which the characters or design are written or engraved. The combination of the motions in the direction of the axis parallel to the surface on which the characters are engraved or written,

## MICROSCOPIC DRAWING AND ENGRAVING.

determines the form of the characters, and the motion in the direction of the axis at right angles to that surface determines the depth of the incision, if it be engraving, or the thickness of the stroke, if it be writing.

33. Having thus explained the principal results of the art of microscopic engraving, it remains to offer some notice of the not

Fig. 27.



APPEARANCE AS SEEN IN THE FIELD OF THE MICROSCOPE, THE OUTER CIRCLE BEING ONLY THE 30TH OF AN INCH IN DIAMETER.

less interesting methods of delineating microscopic objects, or transferring to paper, metals, or wood fac-similes of the appearances presented in the microscope. The methods of accomplishing this have varied with the varying resources presented to art, by the progress of the sciences.

34. The first attempts at delineation of this kind were made by dividing the field of the microscope into a system of squares, by

## DAY FLY.

means of micrometer threads or wires extended transversely to each other across the field of view, as shown in fig. 4. By this means, the field of view was, as it were, mapped out in squares, like lines of latitude and longitude, upon which the magnified images of the objects to be delineated were seen projected. The draftsman having previously prepared on paper a corresponding system of lines, transversely intersecting each other at distances, one from another, determined by the scale of the intended drawing, he proceeded to trace the outlines of the objects, guided by the correspondence between the system of squares upon his paper, and the system of squares seen in the microscope. The outlines being then obtained, which could always be most conveniently done with a low magnifying power, which would include at once within the field the entire object, or objects, to be drawn, the minute details of form and structure, were filled up within the outlines by viewing the parts of the object successively with much higher powers.

Neither this method, nor any other, depending on mere mechanical experience, would admit of being applied to the delineation of living objects, which are liable constantly to shift their positions and change their attitudes. To delineate these, the microscopist must also be an artist, and one of rather a high order; happily, the combination of the two qualities was not unfrequently found, and many beautiful representations, on a magnified scale, of the minuter members of the creation, have been supplied by the researches and talents of microscopic observers.

35. We shall select from these one or two admirable examples supplied by the late Dr. Goring; and it will not be unacceptable to the reader, if we accompany them with a brief account of the objects they represent.

36. For those who have not devoted attention to the history of the insect world, it may be well here to premise, that these little creatures are generally produced from eggs, and that, unlike all other members of the animal kingdom, they pass during their life through three stages of existence, in which their forms, habits, nourishment, and dwellings, differ one from another, for the same individual insect, as widely as do those of a crocodile and a peacock.

37. There is a certain little insect of the class of flies, called a day-fly, because the duration of its life, from the moment it attains the third and perfect stage of its existence never exceeds a day.

This insect deposits its eggs in water, well knowing, as it would seem, that its young, when hatched, are destined to be aquatic animals, although it is itself one of the gayest animals of the air.

## MICROSCOPIC DRAWING AND ENGRAVING.

In due time, generally towards the decline of summer, the young, breaking the shell, issues from the egg in the form proper to the

Fig. 28.



first of the three stages of its existence, in which it is called a *larva*; its length, when full grown, in this state, is about half an inch, and it is represented in its proper magnitude in fig. 28. It is represented magnified in its linear dimensions  $6\frac{1}{2}$  times; and, therefore, in its superficial dimensions, 42 times, in fig. 29.\*

38. As the larva increases in size, the serpentine vessels attached to its sides become more apparent, and the tail assumes that rich feathered appearance which, in conjunction with the paddles projecting from its sides, constitute one of its most beautiful features.

The body of the insect when young, being very pellucid, its internal organisation may be very clearly seen with the microscope by light transmitted through it. The peristaltic motion of the intestines; the circulation of blood, and the pulsations of the dorsal vessel, which in these creatures supplies the place of a heart, can be observed with the greatest facility. As it grows, it assumes a variety of colours, losing much of its transparency, when it is a few months old; at which time, the period approaches at which it is destined to pass into the second stage of its existence. The eyes, as will be seen in the figure, are large, protuberant, and curiously reticulated; they are of a citron colour. The body exhibits a beautiful play of various tints, finally assuming a rich brown colour, with various shadings.

39. It must be here observed, that the important function of respiration is performed in a very different manner, by different animals; the breathing apparatus being always admirably adapted to the element which they inhabit. The higher class of animals respire through the mouth and nose. Fishes take air through their gills, and insects through orifices provided for the purpose, either in the hinder extremity of their bodies, or along their sides. From these openings, the air passes through, and inflates vessels called tracheæ, which extend along their sides; in these it encounters the blood, on which it produces effects similar to those produced in the superior animals. These vessels appear in the figure running along each side of the body, and throwing out numerous ramifications which traverse the several leaf-shaped paddles projecting from the body.

The orifices by which air is supplied to the tracheæ for respira-

\* This figure and the succeeding ones, drawn by Dr. Goring, have been copied with the permission of Mr. Pritchard from the microscopic illustrations.

Fig. 29.

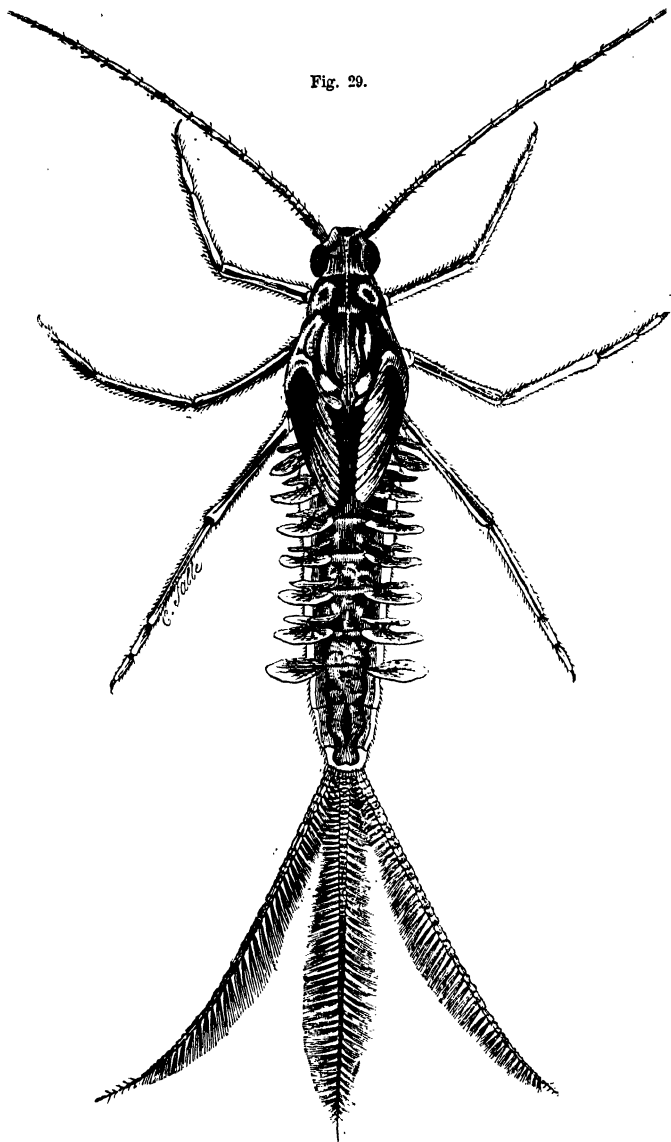

MAGNIFIED VIEW OF THE LARVA OF THE DAY-FLY. DRAWN BY DR. GORING.



## MICROSCOPIC DRAWING AND ENGRAVING.

tion, are situated in the membranous paddles, or swimmers, projecting on either side of the body; they imbibe the air from the circumambient fluid which passes from them into the tracheæ.

Ramifications of the tracheæ extend along the legs, the antennæ, which diverge from the head, and along the three-forked tail; small oblong corpuscles of blood may be seen passing rapidly around the tracheæ with every pulsation of the dorsal vessel. This vessel, says Mr. Bowerbank, extends nearly along the whole length of the body, and is of great comparative magnitude; it is furnished at regular intervals with double valves, one pair for each section of the body.

A portion of this vessel, with its valves, is represented as seen under a higher magnifying power in fig. 30.

The action of these valves is a most interesting and beautiful spectacle. While in the greatest state of collapse the point of the

Fig. 30.

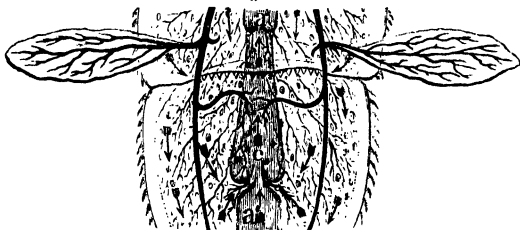

lower valve is seen closely compressed within the upper one. At the commencement of the expansion of the artery, the blood is seen flowing in from the lateral apertures, as shown by the arrows in the figure, and at the same time the stream in the artery commences its ascent; when it has nearly attained its greatest state of expansion, the sides of the lower valve are forced upwards by the increasing flow of the blood from the section below the valve, the lateral openings are closed, and the main current of the blood forces its way through the two valves.

40. The three-pronged tail is beautifully fringed with bunches of fine hair, as shown in the figure. As the time approaches at which the insect is destined to pass into its next stage of existence, the central prong of the tail becomes more transparent, and assumes the appearance of a jointed tube or sheath; the two external prongs, at the same time, exhibit within them parts which are destined to become the tail of the insect in the third stage of its life.

The rapidity with which this creature moves is truly surprising; besides its six legs, it is furnished with the six double paddles attached diagonally to the serpentine vessels on each side of its

## THE PERFECT INSECT.

body, and with its tail, all of which it employs for rowing, balancing, and guiding itself in the water, the tail playing the part of the rudder.

41. Such is the mobility of these members, that even when the creature is in repose, all the paddles are in rapid motion; the steering prong of the tail alone being at rest.

Independent of its faculty of locomotion by means of its legs, paddles, and tail, it possesses a power of leaping and springing in the water, by bending its body backwards, and then suddenly straightening it; by this movement it raises itself to the surface with great celerity.

42. During the second stage of the life of this insect, called the state of chrysalis, it retains the faculty of swimming; its motions are altogether subservient to its will, and it leaps with great alacrity. As the epoch, however, approaches at which it is to pass into the third and most perfect state, in which it receives the name of day-fly, some parts of it assume a metallic lustre, just as if the thin casing in which it is wrapped like a mummy, were partly filled with mercury; this casing is so thin and translucent, that every part of the body of the perfect insect, which is soon about to emerge from it, is plainly enough visible through it. The metallic appearance, just mentioned, is supposed to arise from the evolution of a small quantity of gas from the body of the insect in the change which it is undergoing; this gas, by insinuating itself between the case of the chrysalis and the body of the insect, helps to detach the former from the latter, and thus facilitates the natural process by which the insect emerges from its prison. The envelope of the chrysalis is adapted to the form and members of the insect, just as a glove is to the hand, so that after the insect has escaped from it, this envelope will exhibit with great precision its shape and proportions.

43. When the creature has divested itself of its envelope, it remains apparently inert for a few minutes on some neighbouring

Fig. 31.

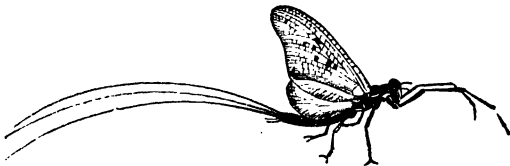

plant, where it carefully cleanses its wings, and divests them of the last pellicle of the sheath in which they had been inserted; it then assumes the beautiful form, and exercises the functions

## MICROSCOPIC DRAWING AND ENGRAVING.

which appertain to it in the perfect state, and becomes the day-fly shown in fig. 31.

44. It now rises upon its wings into its new element, the air, where it joins tens of thousands of its fellows, who have almost simultaneously undergone a similar transformation. In the fine afternoons of summer and autumn, swarms of these creatures may be seen hovering in the air, all of them having emerged the same day from the state of chrysalis. Each female in these flights seeks its mate; which having chosen, they retire together to the leaves of some neighbouring plants. Immediately after their conjugal union, their proceedings are such as would be prompted by the tenderest parental solicitude for their future offspring, which, however, they are never destined to behold. Conscious, apparently, that their young must inhabit a very different element from that in which their short existence passes, they fly off in quest of water, in which, when found, the provident mother deposits her eggs, collected in a little packet in which they can float; the parents then abandon them to the warmth of the atmosphere, by which they are subsequently hatched, and having thus performed the last and most important duty of their life, that of increasing and multiplying their species, drop dead, the whole period of the existence of this gay insect being limited to a few hours of a summer afternoon.

45. So imperious is the will of nature in enforcing her laws, that if by artificial interference, the insect after emerging from the envelope of the chrysalis be prevented from joining its fellows and kept in solitude, its life will be prolonged far beyond its natural term, as if it lived only for the performance of the duty prescribed to it by its Maker. Dr. Goring ascertained this fact by catching a day-fly just emerged from the chrysalis, which he imprisoned for several days, during which it continued to live; he observed that in such cases the insect did not seem at all enfeebled, even when thus confined for a week, so that upon being liberated it flew briskly away, found its mate, produced and provided for its eggs, and immediately died.

46. It is remarkable that these little creatures, during their ephemeral existence, take no food; the only function they exercise being that of propagation.

47. It appears, that in some localities, these flies prevail in such countless numbers that their bodies are found after death covering the ground to a considerable depth, and they are collected in cart loads by the agriculturists, who use them for the purpose of manure.

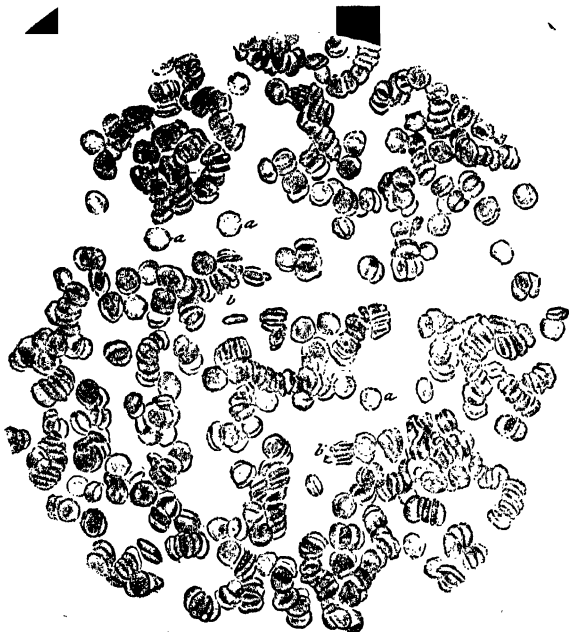

Fig. 33.—VIEW OF A THIN DISC OF HUMAN BLOOD, PRESSED BETWEEN TWO PLATES OF GLASS, THE REAL DIAMETER OF THE PART SHOWN BEING THE 120TH OF AN INCH, DAGUERREOTYPED BY MESSRS. DONNÉ AND FOUCAULT.

## MICROSCOPIC DRAWING & ENGRAVING.

### CHAPTER III.

48. The beetle.—49. Its larva.—50. Drawing of it in its natural size.—51. Dr. Goring's magnified drawing.—52. Production of the beetle from the egg.—53. The young larva.—54. Its voracity and manner of seizing its prey.—55. Description of its organs.—56. Its chrysalis.—57. Water-beetle.—58. Gnat.—59. Dr. Goring's method of drawing.—60. Drawing by the camera-lucida.—61. Section of the human skin; sweating-gland and duct.—62. The itch insect.—63. Method of obtaining it.

48. ANOTHER of the tribe of insects, of whose larva Dr. Goring has left a beautiful drawing, is the beetle, shown in fig. 32.

49. The larva of this insect, like the former, is an inhabitant of the water. It is remarkable for its ferocious and savage disposition,

## MICROSCOPIC DRAWING AND ENGRAVING.

and for the various organs supplied to it by nature for the gratification of its ravenous propensities. It may be truly affirmed

Fig. 32

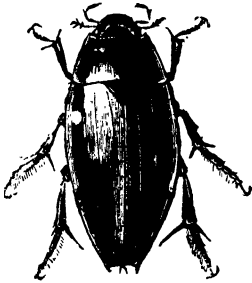

that no similar creature is provided with weapons of destruction so powerful, so numerous, and so perfectly adapted to their end; it is on this account, that the insect, in this first state of its existence, has been vulgarly called the "water-devil." Its length, when full grown, is about an inch and a half, and the strength, courage, and ferocity with which it attacks small fish and other aquatic animals larger than itself, are truly surprising.

50. The representation of this creature, in its natural size, when young, and before it has reached its full growth, is given in fig. 33.

Fig. 33.



51. The magnified representation of it given in fig. 34, has been engraved from Dr. Goring's drawing.

52. In the first months of Spring, small nests containing the eggs of these insects, may be seen floating among the weeds, in stagnant pools; they are formed like balls, of a dusky-white colour, and silky texture; they are attached to the roots or stalks of weeds at the bottom of the water by a thin stem of the same material as the nest, but stronger and more dense. Thus placed, they remain during the winter preserved from the effects of cold, even when the surface of the water is frozen over; since by a natural thermal law the temperature increases in going downwards.\*

Early in spring, the stem or thread by which they are attached to the weeds, is broken by the winds, and the nest being detached and lighter, bulk for bulk, than the water, rises by its buoyancy to the surface, where being exposed to the warmth of the sun as the season advances, the eggs are hatched. The larva, however, after breaking the shell, is still confined in the bag-shaped nest; it accomplishes its liberation by gnawing a hole in it, from which escaping, it dives immediately to the bottom, eagerly devouring all the small aquatic insects that fall in its way. If, however, it should happen that there is a short supply of this food, the voracity of these creatures is such, that they fall upon and devour each other.

53. When the larva is very young, measuring not above a quarter of an inch in length, it is sufficiently translucent to enable an observer to see its internal structure with the microscope, by light

\* See Tract on "Terrestrial Heat," also Handbook of Natural Philosophy, "Heat."

THE WATER DEVIL.

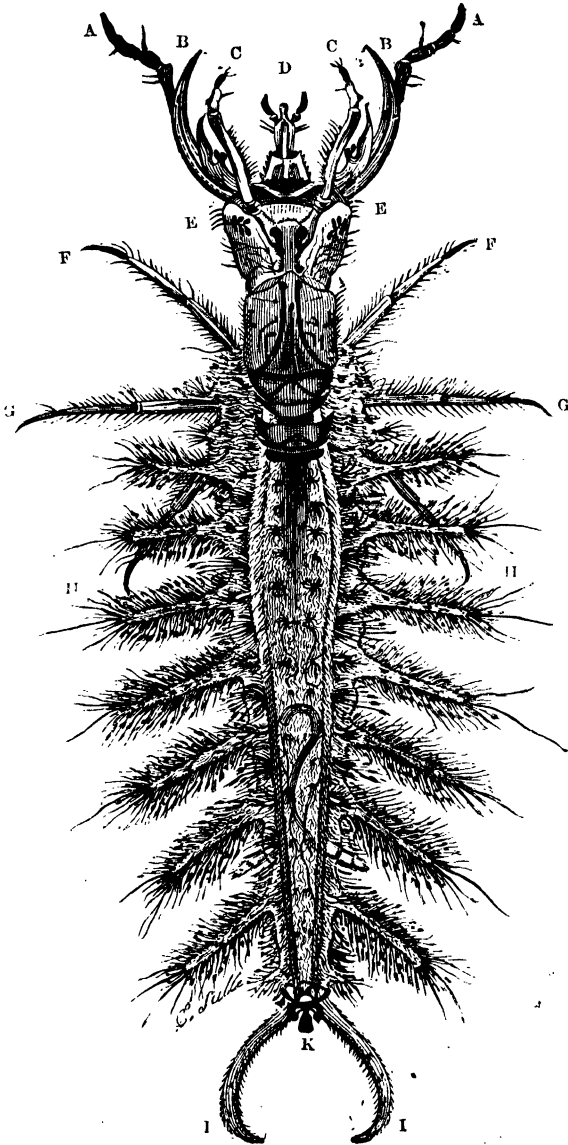

FIG. 34.—MAGNIFIED VIEW OF THE WATER-DEVIL OR LARVA OF THE BEETLE. DRAWN BY DR. GORING.

## MICROSCOPIC DRAWING AND ENGRAVING.

transmitted through it. The colour of the head is then a strong Indian yellow, with darker shadings of a bright chesnut. The eyes are a brilliant carmine; its covering of hairs is more sparse than when it arrives at maturity; its swimmers or paddles are shorter, and its head bears a greater proportion to its body.

54. The manner in which it deals with its prey, shows extraordinary intelligence; many of the creatures upon which it feeds, being crustaceous, are invested on the head and back with a shell-armour, being unprotected on the belly and lower part of the body; when they attract the notice of the larva, the latter accomplishes its object by swimming under its intended victim; when sufficiently near, turning its head upwards, it seizes its prey, between its jointed antennæ, A A, fig. 34; having thus secured it, it stabs it in the belly with its sharp mandibles, B B, so as to disable it, it then rises to the surface of the water, and holding its victim above the surface, so as to prevent it from struggling, shakes it, as a dog would a rat.

Its next operation is to pierce it with a weapon represented at D, which issues from a horny sheath; this instrument, when not in use, is withdrawn into the sheath. As shown in the figure, it is protruded from the sheath to about three-fourths of its length. This curious weapon consists of a piercer and sucker, the one giving the wound and the other drawing the blood or other juices. When from the nature of the part attacked, this weapon fails of its purpose, the victim is seized between the serrated hooks of a pair of forceps, C C, by which it is torn to pieces, and the juices more easily approached by the sucker, D.

55. When supplied with abundant food, this creature arrives at its full growth in three or four months, and is then nearly opaque and covered with hair. When caught and kept several days without food, its ferocity is greatly increased, so that it will attack insects much larger than itself, if supplied to it, and will even devour other individuals of its own species. Its prudence and intelligence, however, are displayed by studiously avoiding those with whom a contest would be dangerous to it, such for example as the water-scorpion.

The eyes are compound, but of a very peculiar formation, consisting of seven oval pupils, arranged like leaves on each side of a stem, as shown at E E; the entire head and chest are curiously marked with lines and spots.

There are three pair of legs, the fore legs F F, the hind legs H H, and the middle legs G G; each leg terminates in a sharp claw. Projecting from each side of the body are seven swimmers or paddles, similar in their position and arrangement, though not in their structure to those of the larva of the day-fly already described; they are

## THE WATER DEVIL.

here covered with hairs, and in the specimen from which the drawing has been made, a vast number of minute bell-shaped animalcules were attached to them, which will be recognised in the figure.

The abdomen is united to the chest or thorax a little above the first pair of swimmers, and extends to the commencement of the bifurcated tail; along the sides of the abdomen are extended the two tracheæ or air-vessels, which as already explained perform the functions of lungs; they are in this case of a light blue colour, and throw out numerous branches at various intervals in their course. These tracheæ consist of curiously formed fibres, winding round them like the twisted filaments of a rope, as may be seen in the figure. These vessels are usually distended by the air which inflates them; their diameter in a full-grown larva is about the sixteenth of an inch.

Dr. Goring states that when these membranes are submitted to examination with the microscope in the usual way, they exhibit the most beautiful specimen of line-work that it is possible to imagine. The filaments of the upper and under sides, intersecting each other at different angles, produce an effect which could not be surpassed by the finest and most beautiful engine-turning.

The orifices by which respiration is performed are at its tail, and each time that it makes an inspiration, it is obliged to ascend to the surface, above which it projects its tail, through the apertures of which it draws in air, until the entire tracheæ have been inflated; thus provided, it sinks again into its proper element, and according as the air thus inspired has changed its character by contact with the blood, and has therefore been rendered unfit for the support of life, it is expelled from the same orifices in the tail at which it entered, and may be seen rising in bubbles to the surface.

Dr. Goring observes that a comparison of the organs of respiration of this insect with those of a caterpillar, affords a beautiful example of the adaptation of their organisation to the elements in which they live. In the case of the caterpillar, every part being constantly exposed to the atmosphere, mouths or orifices for inhaling the air are arranged along both sides of the body; while in the aquatic larva, this system could not be made available without compelling the creature to elevate its entire body out of the water, each time it makes an inspiration. The necessity for this is superseded by placing the breathing-mouths in the tail.

While admitting the admirable fitness of this arrangement in the two classes of insects, it must not be forgotten, that in the case of the larva of the day-fly, also an aquatic insect, formerly mentioned, the breathing-mouths, according to Dr. Goring's



## MICROSCOPIC DRAWING AND ENGRAVING.

description, are placed in the membranous paddles along its sides, and the air is imbibed from the surrounding fluid.

56. After this creature has remained for a considerable time in the state of larva, and when it appears to become conscious that the epoch of its passage into the second stage of its existence, that of chrysalis, is approaching, it issues from the water and proceeds to excavate for itself a hole in the ground, in which it undergoes the metamorphosis by which it passes into the state of a chrysalis, in which it remains for some days, after which it emerges a perfect beetle.

The female bears on each side of the hinder extremity of her body a spinning apparatus, which she uses to make the bag in which her eggs are deposited, and which has been already described.

57. Dr. Goring has also left a drawing of another species of dytiscus, called the *water-beetle*.

This insect resembles, in the manner of its propagation and its habits, that which has been above described. It is carnivorous, and of a ferocious and cruel character. If it is placed in a vessel with other aquatic insects, it soon devours them.

A magnified view of it is shown in fig. 35; the insect, in its real size, being represented in the lower figure. The drawing from which this engraving was taken, was made immediately after it had cast its first skin, a moment at which its internal organisation is more distinctly visible than at any other period of its existence, by reason of the thinness and transparency of its newly-developed vessels. Its anatomical structure is more delicate and beautiful than that of any other larva of the order of coleoptera, and, although its weapons of attack appear less formidable than those of the water-devil and some other species, the remarkable manner in which its internal functions are rendered visible more than compensate for this, when the insect is regarded merely as a microscopic object.

It is armed with a pair of curved mandibles, which move horizontally, and are long enough to cross each other when closed. They are of a fine nut colour, becoming darker towards the points, which are hard and sharp. With these the insect seizes its prey, and bringing it towards its mouth, sucks its blood after having first pierced it. This it delights to do without killing its victim, unless it is constrained to do so, by the superior strength of the latter. If it seizes the larva of the gnat, or any other tender insect, it brings different parts of its body to its mouth, devouring it piecemeal, except the skin, which it rejects. If its prey is a strong animal, protected by an external shell, it seizes it, and holds it for some time at rest, until its victim

# WATER-BEETLE.

becomes completely exhausted ; or, having wounded it in several places, it turns it upon its back and sucks its juices.

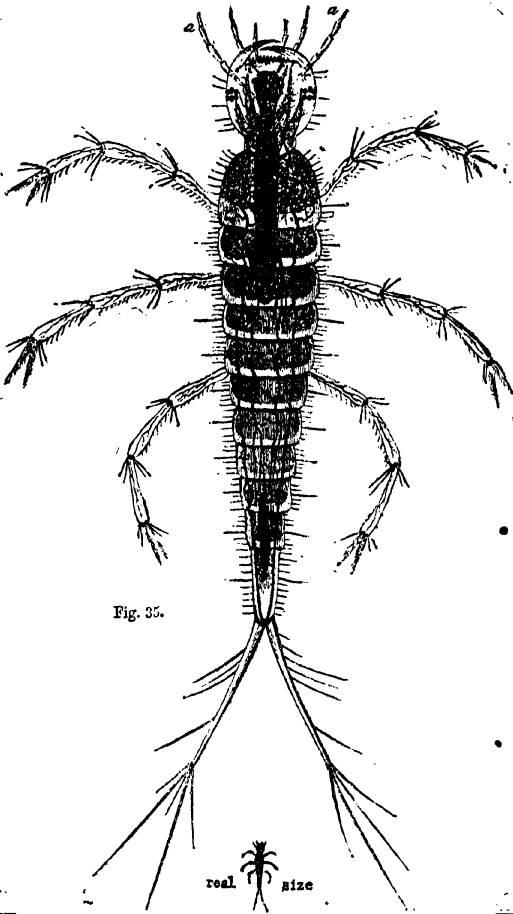

Fig. 35.

real size

## MICROSCOPIC DRAWING AND ENGRAVING.

These larvæ swim with great agility, the hind legs acting together in concert like those of a frog; the antennæ being at the same time erected, and the palpi concealed. The voracity of this creature is not directed alone to aquatic insects, but proves often very destructive to young fish in fish-ponds. Mr. Anderson, the curator of the Chelsea Botanic Gardens, informs Mr. Westwood, that he suffered much from these insects attacking young gold and silver fish, eating their dorsal and pectoral fins. Dr. Burmeister also mentions, that a specimen which he kept, devoured two frogs in the space of forty hours, and, nevertheless, when he dissected it shortly afterwards, it was found to have entirely digested them. They are very fearless in their attacks, seizing insects much larger than themselves. They employ their fore-legs as claws in seizing their prey.

A specimen which Esper kept in water alive for three years and a half, feeding it with raw beef, is recorded by Clairville to have destroyed a specimen, twice its own size, of the large hydruspicious, piercing it with its jaws, at the junction of the head and thorax, its only vulnerable point. Dr. Esper observed that his specimen sucked the blood of the bits of meat with which he furnished it, and that the residue of them appeared like small white masses floating on the water.

According to Esper and Erichson, they are, however, able to fast for many weeks, and even months, provided they are kept in water, but die, if withdrawn from it, in a few days. They are observed to ascend frequently to the surface to obtain air for respiration, where they may be observed in sunny weather resting with the extremity of their body protruded above the water, and their legs extended at right angles.

They may be often seen in a calm summer evening issuing from the water and creeping up the stalks of rushes, from which, after a little time, they take flight, rising into the air perpendicularly until they are out of sight. Their descent is also perpendicular, dropping with considerable force into the water. It would also appear that it is by the reflection of the light from the surface of the water, that they are informed of a proper place for their descent, Mr. Westwood having several times seen them fall with violence upon glazed garden-frames, which they had evidently mistaken for water.

They are to be found in all seasons of the year, but more frequently towards the autumn. During the winter some remain in the water, or bury themselves in the mud, in a torpid state; others retain their agility, and may be seen coming to take air in places where the ice is broken. Mr. Westwood has seen them even swimming about in the water under the ice on which he was skating.

## WATER-BEETLE.

The female deposits her eggs about the beginning of spring, each laying consisting of from forty to fifty eggs of a long and cylindrical form, which are deposited in the water at random, the larvæ being hatched in the course of a fortnight.

The larva of the *dytiscus marginalis* is very active, and casts its skin, for the first time, when four or five days old. The second moulting takes place after an equal interval, and as the insect continues to grow, it casts its skin at intervals of about ten days. The hide which it throws off may often be observed floating on the water, with the mandibles, tail, and its appendages attached. These larvæ are of a dark ochre, or dirty brown colour, with the body long and subcylindric, more slender at each extremity, but especially towards the tail. The body consists of eleven segments, exclusive of the head. The first nine segments are somewhat scaly above, but fleshy beneath. The first segment is longer and narrower than the following. The sixth, seventh, and eighth, are larger than the others, which are of nearly equal size, and the two terminal joints are long and conical; the apex being slightly truncated and scaly, with the sides fringed with hairs, whereby the insect is enabled to swim along in the water, the action of these joints being the same as that of an oar used in sculling a boat.

The terminal segment of the tails is provided with a pair of long and slender pilose appendages, whereby the insect is enabled to suspend itself at the surface of the water, which, as Swammerdam says, flows from them on every side, and thus the suspension is effected. These appendages are tubular, and communicate with the air-vessels which run along the sides of the body, which is moreover furnished with a series of spiracular points, as shown in the figure. The head is large, rounded, and depressed, and united to the first segment of the body by a short neck, with five or six small elevated tubercles representing the eyes. There are two slender antennæ, shown at *a a* in the fig. 35, having a length nearly equal to the diameter of the head, inserted in front of the eyes, and composed of seven joints. The mouth is remarkably constructed, being destitute of the ordinary aperture, so that the insect may be, and, indeed, has been, described as wanting a mouth.

The mandibles, which appear in the figure projecting from the front of the head, are hollow, having a longitudinal slit near the extremity, so as to enable the creature to suck through them the juices of its prey, as a liquid is sucked through a straw or a quill, the juices thus running down the mandibles into the mouth.

The legs of the insect are long, slender, and ciliated on the inside, serving as oars when swimming quickly. The body,

## MICROSCOPIC DRAWING AND ENGRAVING.

generally straight, curves itself in the shape of the letter S when the creature seizes its prey. During the summer the larva is said to attain its full size in about fifteen days, when it quits the water and creeps into the neighbouring earth, where it forms with considerable skill a round cell, in which, in about five days, it changes to a pupa of a whitish colour, with two obtuse points at the extremity of the body. In about a fortnight or three weeks it issues as a perfect beetle. If, however, the change to the pupa state take place in the autumn, the creature does not pass into the form of a perfect insect until the following spring.

The beetle is at first soft and yellowish, but soon hardens and assumes a darker colour. It is not, however, until the end of eight days, that it has acquired its proper consistency.\*

Dr. Goring, in describing the specimen from which the drawing was taken, says that the three first segments of the body, commencing from the neck, contain a bundle of nerves, terminating with three loops, which are very perceptible in the young larva, being of a colour more brilliant than the other parts of the body. They are shown in the figure like a bundle of strings or cords, extending from the centre of the head to the extremity of the third joint of the body.

The two large tracheæ, commencing from the head, attain their greatest development about the third joint of the body. They follow the sides of the body to a point near its extremity, where they coalesce and terminate. These air-tubes, in their passage along the body, throw out numerous ramifications, which are shown in the figure. These tracheæ are four in number, two interior and two exterior. The interior ones commence at the ganglion, which terminates at the third joint of the body, and they disappear at the third joint from the tail. In the last joint but one is situated the organ of pulsation.

58. Dr. Goring has also left two very beautiful engravings of the larva and the pupa of the gnat, taken from a specimen of the species called *tipula crystallina* of De Geer, the *chironomus plumicornis* of Fabricius, and the *corethra plumicornis* of Stephens. I have reproduced these beautiful objects from Dr. Goring's engravings, the larva being represented in fig. 1, the pupa in fig. 2, and a plan, or bird's-eye view of the larva, in its natural size, in fig. 3.

The gnat, of which these are the previous forms, is represented in fig. 36, the drawing having been taken while the creature was in the act of laying the cluster of eggs figured on the right side. The short line between the figures gives the real length of the

\* Westwood on "Insects," vol. i., p. 95.

STRAW-COLOURED GNAT

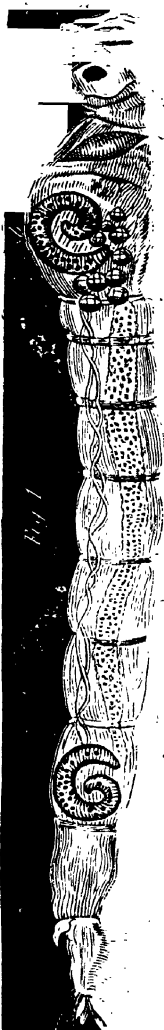

Fig. 1



Fig. 2

Fig. 3

## MICROSCOPIC DRAWING AND ENGRAVING.

body of the insect. The length of the eggs varies from the 40th to the 50th of an inch.

In the larva (fig. 1) the obvious and curious parts are the kidney-shaped bodies, *b* and *d*, two of which are situated near the

Fig. 36.



head, and the other two in the third division from the lower extremity. The first pair are inclined towards each other, while the others lie in parallel planes, as represented in the plan, or bird's-eye view, drawn of the natural size in fig. 3. Physiologists have not ascertained what may be the functions performed by these singular organs: it is worthy of remark, however, that a similar structure is observable in the tadpole, and figured in Sir Everard Home's Lectures on Comparative Anatomy. The other parts of its structure, which appear equally singular and curious, are a number of globules, *a*, which are situated near the first pair of bodies, *b*. These globules have a slight oscillatory motion in different directions, and, like the reniform bodies, seem to have a metallic lustre, but are not opaque. From the exquisite polish of these globules, they reflect the forms of surrounding objects, as window-bars, &c., which are indicated in the drawing by small squares, resembling the images formed by convex mirrors.

When the larva, as shown of the full size in fig. 3, is examined from above, it exhibits the position and decussation of the various muscles lying along the back, which are observed to cross at the joints, and at points situate midway between them.

The alimentary canal appears to contain some particles of a pinkish coloured matter: but every part of the object, as seen beneath the microscope, is so accurately noted in the drawing, that a more minute description must be deemed superfluous.

If the insect have a sufficient supply of food, it only continues for a few weeks in the larva state, when it rapidly changes to the pupa, shown in the drawing (fig. 2). When it is desirable to

## STRAW-COLOURED GNAT.

preserve it for the microscope, this change may be retarded by keeping it in clear spring or river water. The former seldom offers sustenance to animalcules, and, therefore, effects this object, which is often very desirable, on account of the scarcity of this species.

The transformation of this animal from the larva to the pupa is one of the most singular and wonderful changes that can be conceived; and, under the microscope, presents to the admirer of nature a most curious and interesting spectacle. Although the whole operation be under the immediate inspection of the observer, yet so complete is the change, that its former organisation can scarcely be recognised in its new state of existence.

If we now compare the different parts of the larva with the pupa, we remark a very striking change in the tail, which, in the previous state of being, was composed of twenty-two beautifully plumed branches, while, in the latter, it is converted into two fine membranous tissues, ramified with numerous vessels. This change appears the more remarkable, as not the slightest resemblance can be discovered between them, nor are the vestiges of the former tail readily found in the water. The partial disappearance of the shell-like or reniform bodies is another curious circumstance. The lower two, it may be conjectured, go to form the new tail; for, if the number of joints be counted from the head, the new tail will be found appended to that joint which was nearest to them in the larva state, as referred to by the dotted line *d*, connecting figs. 1 and 2. The two small horns, *c c*, which form the white-plumed antennæ of this species of gnat, when in its perfect state, are discernible in the larva, folded up under the skin near the head at *c*, in fig. 1. The alimentary canal appears nearly to vanish in the pupa, as in that state there is no necessity for it, the insect then entirely abstaining from food; while, near this canal, the two intertwined vessels, seen in the larva, have now become more distinct, and are supplied with several anastomosing branches.

During the latter part of the day on which the drawing (fig. 2) was taken, the rudiments of the legs of the perfect insect might be seen, folded within that part which appears to be the head of the pupa, and several of the globules had vanished, those remaining longest that were situated near the head. It may be necessary to observe, that the head of the pupa floats just under the surface of the water; and the insect, in this state, is nearly upright in that fluid, while the larva swims with its body in a horizontal position, or rests on its belly or sides, at the bottom of the pond or vessel in which it is kept, the fringed tail being downwards.

The colour of the larva when young is a faint and scarcely perceptible yellow; but as it approaches the change, it assumes a



## MICROSCOPIC DRAWING AND ENGRAVING.

richer and deeper colouring, and all its internal parts acquire their definite forms and tints, as exhibited in the drawing.

A curious circumstance attends the observation of this insect; so rapid is its locomotion, that it torments the eye while attempting to delineate it, presenting alternately its head and tail to the observer. This it effects by bending itself laterally into a circular form, and suddenly whisking round in the opposite direction to that in which it had just bent itself.

Many species of this genus of insects are, in their perfect state, possessed of a sheathed proboscis, containing instruments with which they are enabled to pierce the skin of men and cattle, injecting at the same time an acrimonious fluid into the wound. The species we are now describing, however, has not been examined minutely enough to determine the form of these organs. It is of a light straw colour, and has two beautiful antennæ, or feelers.

The wings also of this gnat are of a delicate straw colour, and make very beautiful objects when mounted under thin glass in sliders. Some species have wings marginated, and covered with fine scales. These, as well as the feathers on the edges, are good objects for the microscope, and exhibit five or six longitudinal lines on each, which are so strongly marked as to be seen with any kind of light, and do not require superior penetration in the instrument to show them.

These insects generate while hovering in the air, and the female lays her eggs in the water, selecting an unfrequented spot, where she may deposit them free from danger. This is probably the cause why this larva is discovered with so much difficulty; the collector being seldom able to procure it two seasons consecutively in the same place.

59. The method of executing these drawings, practised by Dr. Goring, differed in nothing from that by which an artist makes a portrait, the eye guiding the pencil, and the accuracy of the resemblance depending altogether upon the skill of the artist.

60. Dr. Goring considered that in such cases the great security for precision offered by the camera-lucida, was not available, owing to the constant mobility of the object delineated; this objection, however, is only applicable to living objects, and that admirable instrument is accordingly used to a great extent in the production of microscopic drawings. As we shall describe it in a future Tract, and explain its mode of application to the microscope, it will not be necessary here to give that exposition. \*It will be sufficient to observe that a practised draughtsman is capable of giving, not only the general outline, but most of the less minute details of a microscopic object, by a

## THE ITCH INSECT.

process precisely similar to, and susceptible of, as much accuracy as that by which a drawing is reproduced on tracing paper. It must be observed, however, that in the finishing touches, and the most minute details, the pencil of the draughtsman must after all be guided by his artistic skill. To what extent this is true, is proved by the fact, that two drawings of the same object, viewed in the same microscope, and made with the same camera, by artists of different skill, will be different.

We shall here, as in the former case, present the reader with some examples of microscopic drawings made by the aid of the camera.

61. In fig. 41 is a magnified section of the human skin, cut inwards at right angles to its surface, to the depth of about the sixth of an inch. The following is the succession of organised parts included within that depth:—*a* the sudoriferous gland; *b c* the sudoriferous duct, leading to the surface of the skin; *d* the subcutaneous cellular and adipose tissue; *e* the derma or true skin; *f* the papillæ; *g* mucous tissue or interior epidermis; *h* the epidermis or superficial skin.

62. It is now admitted, though the fact was long doubted, that the malady called the itch in the human body, and that called the mange in the horse, are produced by an insect hatched under the cuticle of the skin; the insect which produces the itch, called the *acarus-scabiei*, is represented, highly magnified, in fig. 42. To extract this insect, the operator must, says Mr. Quekett, examine carefully the parts surrounding each pustule, and he will generally find, in the early stage of the disease, a red spot or line communicating with it; this part, and not the pustule, must be probed with a pointed instrument, and the insect, if present, turned out of its lurking-place. The operator must not be disappointed by repeated failures, as in the best marked cases, it is often difficult to detect the haunts of the creature.

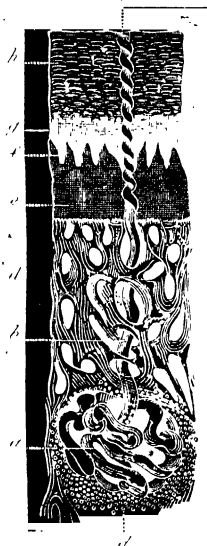

FIG. 41.—MAGNIFIED SECTION OF THE HUMAN SKIN, SHOWING THE PERSPIRATORY GLAND, WITH ITS DUCT, DRAWN WITH A CAMERA BY DR. MANDL.

## MICROSCOPIC DRAWING AND ENGRAVING.

63. That the itch is occasioned by such an insect is by no means a modern doctrine. Kirby mentions a Moorish physician, who, in the twelfth century, affirmed that the malady was produced by little mites or lice that creep under the skin of the hands, legs, and feet, producing pustules full of matter; he quotes also "Joubert," another ancient physician, who describes

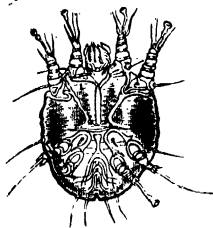

Fig. 42.—VIEW OF THE ITCH INSECT, DRAWN WITH A CAMERA BY DR. MANDL, MAGNIFIED 120 TIMES IN ITS LINEAR, AND THEREFORE 14400 TIMES IN ITS SUPERFICIAL DIMENSIONS.

the itch insects under the name of "sirones," and says they are always concealed beneath the epidermis, under which they creep like moles, gnawing it, and producing a most troublesome itching. It was supposed by some that they were identical with lice; but Dr. Adams showed that this could not be the case, since they live under the cuticle; he speaks of them as living in burrows which they have excavated in the skin, near a lake of water, from which if they be extracted with a needle, and put upon the nail, they show in the sun their red heads and the feet with which they walk; they have been extracted and delineated with the aid of the microscope by many modern observers. The individual delineated in fig. 42, was drawn by my friend Dr. Mandl, well known for his great work on microscopic anatomy.

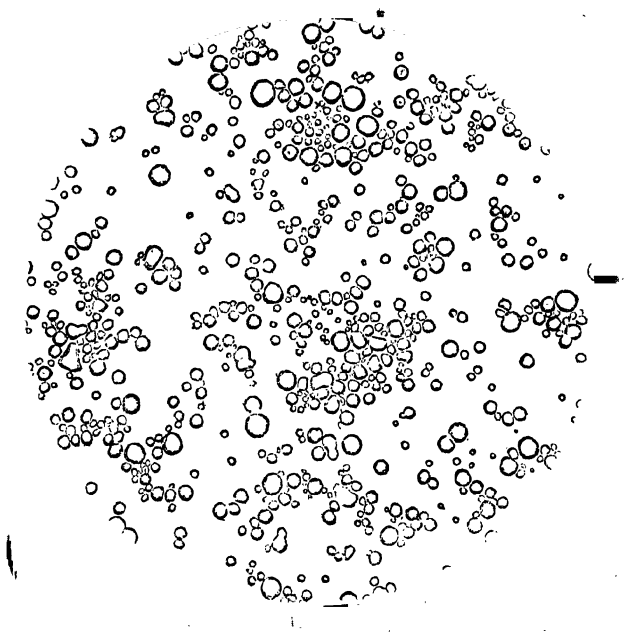

Fig. 40.—THIN DISC OF COW'S MILK, THE 120TH OF AN INCH IN DIAMETER, MAGNIFIED 400 TIMES IN ITS LINEAR, AND 160000 TIMES IN ITS SUPERFICIAL DIMENSIONS.

## MICROSCOPIC DRAWING & ENGRAVING.

### CHAPTER IV.

64. Structure of the itch insect.—65. Its habits.—66. The mange insect.—67. Its form and structure.—68. Defects incidental to drawing with the camera.—69. Microscopic photographs.—70. Microscopic daguerreotypes by Messrs. Donné and Foucault.—71. Description of the blood.—72. Red and white corpuscles.—73. Daguerreotype of a drop of blood magnified.—74. Magnitude of the corpuscles.—75. Cause of the redness of blood.—76. Corpuscles of inferior animals.—77. White globules.—78. White grains.—79. White globules converted into red corpuscles.—80. Red corpuscles dissolved.—81. Circulation of the blood.—82. Method of showing it in the tongue of a frog.—83. The arteries distinguishable from the veins.—84. The vascular system of the tongue.—85. Mucous glands.—86. Milk ; its

## MICROSCOPIC DRAWING AND ENGRAVING.

constitution.—87. Magnified view of a drop of milk.—88. The butter globules.—89. Their number variable.—90. Analysis of the milk of different animals.—91. Richness of woman's milk.—92. Analogy of milk to blood.—93. Importance of the quality of milk.—94. Its richness ascertained.—95. Quévenne's hydrometer applied to milk.—96. Its fallacy.—97. Donné's lactoscope.—98. Objections to it answered.—99. Frauds practised by milk vendors.—100. Fore-milk and after-milk.—101. Self-engraved photographic pictures.

64. DR. BONONIO, having directed his researches to the itch insect, found that it was very nimble in its motions, covered with short hairs, and furnished with a formidable head, from which a pair of strong mandibles projected.

At the extremities of its four pairs of legs, there are feet of remarkable form, each of which is provided with a sucker, by means of which he inferred that it sucks or draws its way under the skin, having first excavated a space for itself with its mandibles. The insects form their nests there, deposit their eggs, and multiply rapidly.

65. More recently, Dr. Bourguignon has studied the habits of this insect by means of a microscope specially adapted to the purpose, and has confirmed the discoveries of Bononio. He found that the insect fastens itself in the furrows of the skin by means of the suckers of its feet, aided by small bristles, being likewise covered with similar bristles in various parts of its body, by which it fixes itself more firmly, while it works its way with its mandibles; it is not furnished with eyes, but in a moment of danger it quickly draws in its head and feet, this motion and that of its gait resembling those of a tortoise. It usually lays sixteen eggs, which it deposits, ranged in pairs, in the furrows under the skin, where they are hatched in about ten days.\*

66. The insect which produces or accompanies the mange in horses, and which is called the *acarus-exulcerans*, is represented in fig. 37, p. 49, magnified in its linear dimensions one hundred and fifty times.

67. This animalcule is larger and more easily obtained than the former; it is found under the whitish scales which are detached from the skin of the horse, and if several individuals be taken, they will be found to be in different states of development, having four pair of legs when full grown; the two foremost pairs are terminated in a strong and sharp claw, and their general form is like that of the legs of a flea, consisting of five joints or segments.

The head consists of nothing but a mouth, in which the organs of mastication are seen, consisting of a pair of very fine and sharp

\* Bourguignon, quoted by "Hogg" on the Microscope, p. 318.

## MICROSCOPIC DAGUERREOTYPES.

mandibles terminated by two teeth, the form of the entire organ being that of a pincers. The skin, which is of a tough leathery texture, is elegantly marked by sinuous and parallel tracings, bearing some resemblance to engine-turning. Wrinkles are in some places seen upon it, as if it were divided into separate segments, united edge to edge, like the bones composing the human skull; upon the legs, the skin is finely granulated and not striated, as upon the body; several long hairs issuing from the legs are seen in the figure.

68. Although the general fidelity of microscopic drawings made with a camera may be relied upon, yet, as has been already observed, the more minute details are executed by the artist in the same manner as that in which a portrait-painter produces his effects, and in whatever degree the artistic skill of the draughtsman may be manifested in such parts of the drawing, the rigorous fidelity demanded by science, even in the minutest arts, cannot be claimed for them.

69. Under these circumstances, other means, ensuring more rigorous accuracy, and rendering the drawing independent altogether of those impulses which imagination and taste never fail to impart to the pencil even of the most conscientious artist, have been eagerly sought by naturalists, and have been happily supplied by photography. The magnified image of the object under examination, produced by a solar microscope, is received upon a prepared daguerreotype-plate, or a leaf of photographic paper, and there the optical image delineates itself with the most unerring fidelity and rigorous accuracy.

70. This felicitous application of the photographic art, to the promotion of natural science, after some experimental essays, more or less successful, was first carried out, so as to be available for the practical purposes of science, by Dr. Donn , assisted by M. Leon Foucault, in 1845. In that year Dr. Donn  published an atlas to illustrate his course on microscopic anatomy and physiology, which had appeared in the previous year, consisting of twenty plates, on each of which were four microscopic engravings, made from daguerreotype plates which had been produced in the manner above described. I avail myself gladly of the kind permission of the authors of this work, and of Mr. Bailli re, its publisher, to reproduce four of these engravings upon the scale on which they are given by the authors.

71. The blood of animals is not, as it seems at first view to be, a homogeneous liquid holding in complete solution certain substances, and destitute of all solid and concrete matter; if it were so, we could not follow its course through the vessels in which it moves, as we do so easily and distinctly with the microscope.

## MICROSCOPIC DRAWING AND ENGRAVING.

The motion of an homogeneous liquid in tubes completely filled with it could not be made sensible to the sight; but on the other hand, that of a liquid containing solid particles suspended in it, continually entering into collision with and displacing each other, would be perfectly visible.

The blood therefore contains certain solid particles floating in and circulating with it, to which moreover are due several of its most important properties; these particles exist in countless numbers, and of minuteness so extreme, that a single drop of blood, no larger than might be suspended from the point of a needle, contains myriads of them. Until recently, observers recognised only one species of the corpuscles, such being the only ones perceivable by the ordinary methods of observation, and being incomparably more numerous than the others, which, besides being more rare, are generally hidden by the former, which completely fill the field of the microscope.

72. These sanguineous corpuscles are distinguished by regular and constant forms, by a complex composition and a determinate structure. They possess a real organisation, and pass through a regular succession of phases, having a beginning, a development, and an end.

They consist of three species: first, red corpuscles; secondly, white globules; and thirdly, white granular particles, much smaller, to which observers have applied the name "globulines."

73. Nothing can be more simple or more facile than the method of observing the first class of these corpuscles. Take a sharp needle and prick with it slightly the end of the finger, so as to draw the smallest drop of blood; having previously rendered a small slip of glass perfectly clean and dry, touch it with the blood, a small portion of which will adhere to it, and upon this lay a thin film of glass, such as are prepared by the opticians for microscopic use, so as to flatten between the two glasses the small drop of blood. Let the glass thus carrying the blood be placed under a microscope having a magnifying power of about 400; a multitude of the red corpuscles will then be immediately visible, distributed irregularly over the field of view of the instrument.

Fig. 38, p. 81, has been reproduced from one of Dr. Donné's engravings; it represents a thin disc of human blood, having a diameter equal to the 120th part of an English inch, included between the two glasses.

The red corpuscles alone are here visible; their form is that of flat discs a little concave in the middle, swelling upwards towards the edges, which are slightly rounded. Some of them, such as *a a a*, are presented with their flat sides to the line of sight, so as to show very distinctly their form; others, such as *b b*, are

## DROP OF BLOOD.

seen edgeways, and others at all degrees of obliquity; some are scattered separately, but others are grouped together in piles, with their edges presented to the eye, having the appearance of rouleaux of coin lying on their sides on a table, the faces of the coins being more or less inclined to the surface of the table.

The flat disc-shape form of the corpuscles was not recognised by the earlier observers, who took them to be red spherules. The cause of this error was not any defect of their observation, but arose from their having previously washed the blood with water, being ignorant that the immediate effect of the contact of water with human blood is to change the form of the flat corpuscles into that of little globes.

74. The magnitude of these corpuscles, since the recent improvements of the microscope, has been very exactly measured. Their diameters are found to vary from the 3125th to the 3000th of an inch: this small variation being due to their different states of development, as will be presently explained.

75. The blood consists of a transparent, limpid, and colourless fluid, in which the solid particles already mentioned float, and the redness of which arises altogether from the colour of the corpuscles here described. A person, who may observe for the first time these corpuscles with the microscope, is generally surprised and disappointed to find that they are not red, but rather of a yellowish colour, having a very faint reddish tint. This circumstance, however, is an optical effect of a very general class, which has been explained more than once in our Tracts. When any coloured medium is submitted to the eye, the depth of its tint will always be diminished with the thickness of the medium, which may be reduced to such a degree of tenuity as to render its peculiar colour altogether imperceptible. We mentioned formerly, as an example of this, the case of coloured wine, such as sherry, viewed through a tapering Champagne glass. At the upper part, where the eye looks through a greater thickness of the liquid, the peculiar gold colour is strongly pronounced; but in going downwards to the point of the cone, the colour becomes paler and paler, and at the very point is scarcely perceptible. It is the same with the red corpuscles of the blood. When they are seen singly through their very minute thickness, they appear of the faintest reddish yellow; seen in rouleaux edgeways, they are redder; but it is only when amassed together, in a stratum of blood of some thickness, that they impart to the liquid the red colour so characteristic of the blood.

76. The disc-shaped form which thus characterises human blood, is common to all species of animals which suckle their young, with the single exception, so far as is known at present,



## MICROSCOPIC DRAWING AND ENGRAVING.

of the camel species. It appears, from some recent observations of Dr. Mandl, that the blood of this species presents an anomalous exception, the red corpuscles being elliptical in their form, but still flat and concave at their sides.

In comparing the red corpuscles of the blood of different species of mammalia, or suckling animals, one with another, they are found to vary in their diameters, being greater or less in different species, but the variation in each species being confined within narrow limits, as in man.

The corpuscles of the blood of birds, fishes, and reptiles, are all like those of the exceptional case of the camel, oval discs of various magnitudes, somewhat concave in their centres, like the blood of mammalia.

77. The discovery of the white globules is entirely due to recent observers, and particularly to Professor Müller, Dr. Mandl, and Dr. Donné.

The white globules have nothing in common with the red corpuscles, either as to colour, form, or composition. Unlike the latter, they are spherical, their contour is slightly fringed, and not well defined like that of the red corpuscles; their surface is granulated, and their diameter is a little greater, varying from the 2500th to the 3000th of an inch. They appear to consist of a thin vesicle, or envelope, the interior of which is filled with solid granulated matter, consisting usually of three or four grains, while the red corpuscles are filled with an homogeneous and semi-fluid matter in the case of mammalia, and a single solid kernel in the case of other vertebrated animals.

The white globules also have chemical properties totally different from those of the red corpuscles.

78. In fine, the third class of solid particles which float in the blood cannot be properly denominated globules, being only very minute granulations, which are continually supplied by the chyle to the sanguineous fluid; they appear in the microscope as minute roundish grains, isolated, or irregularly agglomerated, and having a diameter not exceeding the 8000th of an inch: they have, however, a physiological importance of the first order, since they are the primary elements of the blood, and therefore of all the other organised parts of the body.

79. It appears to follow from the observations, researches, experiments, and reasoning of Dr. Donné, that these granular particles form themselves into the white globules by grouping themselves together, and investing themselves with an albuminous envelope. By a subsequent process, the white globules are converted gradually into the red corpuscles, the place where this change is produced being supposed by Dr. Donné to be the spleen.

## CIRCULATION OF THE BLOOD.

80. In fine, the red corpuscles, after having been fully developed in the circulation, are dissolved, and being converted into the fibrinous fluid, pass into the other parts of the organisation, so as to form the different organs of the system.

81. Next to the constitution of the blood, no subject connected with it is more interesting and important than its circulation, and we know no spectacle presented by any of the scientific artifices, by which the secret operations of nature are disclosed to our view, which excites more astonishment and admiration than the circulation of the blood, as rendered visible with the microscope.

82. Let any one imagine an animal organ, full of every variety of blood-vessels of the most complex structure, into the composition of which enter every form of organ: arteries, veins, capillaries, muscles, nerves, glands, and membranes: representing in short a microcosm of the whole animal organisation; and let us suppose this brought within the field of the microscope, so as to display, before the wondering view of the observer, all the complicated motions and operations of which it is the theatre. Such a spectacle is presented by the tongue of the frog, an object first submitted to this species of experiment by Dr. Donné, at the suggestion of a young Englishman, a Mr., since Dr., Waller, who was in attendance upon his course. The method of accomplishing this, with some modifications, as described in the *Physiological Journal*, is as follows:—"A piece of cork, from two to three inches in breadth, and six to eight inches in length, is to be procured, in which is to be bored, a hole of about half an inch in diameter midway between the sides, and about an inch and a half to two inches from one of its ends. In this part the piece of cork should be of double thickness, which is effected by joining, by means of marine glue, a small piece of cork upon the first piece. Upon this is laid the frog, previously enveloped in a linen band, or fixed to the cork by pins thrust through the four extremities, so as to prevent any great movements of its body or its feet; it is placed upon the back, the end of the nose abutting on the border of the hole. The tongue, the free end of which is directed backwards, is then to be drawn out of the mouth gently with a forceps, and slightly stretched and elongated until it reaches a little beyond the opposite edge of the hole, where it is to be fastened by two pins; the sides are to be fastened over the hole in a similar way. In this state, the tongue presents the appearance of a semi-transparent membrane, which permits us to see through its substance; and when placed between the light and the object-glass of the microscope, offers one of the most beautiful and marvellous spectacles which can possibly be witnessed. It will be found most

## MICROSCOPIC DRAWING AND ENGRAVING.

convenient to view it, first, with a simple magnifying-glass, having a power of 15 to 20, so as to obtain a general view of the vessels and of the circulation; even with this small power the observer will be filled with astonishment at the magnificence of the spectacle, especially if a strong light is thrown upon the lower side of the tongue. To imagine a geographical map to become suddenly animated, by their proper motions being imparted to all the rivers delineated upon it, with their tributaries and affluents, from their fountains to their embouchures, would afford a most imperfect idea of this object, in which is rendered plainly visible, not only the motion of the blood through the great arterial trunks, and thence through all their branches and ramifications to the capillaries, but also its complicated vorticular motions in the glands, its return through the smaller ramifications of the veins to the larger trunk veins, and its departure thence *en route* for the heart. Such is the astonishing spectacle, circumscribed within a circle having the diameter of the 120th of an inch, magnified, however, 400 times in its linear, and therefore 160000 times in its superficial dimensions, which has been daguerrotyped by Messrs. Donné and Foucault, and which is reproduced on the same scale in fig. 39, p. 65.

83. The arteries are distinguishable from the veins very readily, by observing the direction in which the blood flows, its velocity, and their comparative calibre. In the arteries the blood flows from the trunk to the branches, its course is marked by the arrows in fig. 39, where *t* is a trunk-artery entering near the lowest point of the field of view; the arrows show the course of the blood passing into the principal branches, 1, 2, and 3, from which it flows into all the smaller arterial ramifications. The course of the blood in the veins, on the contrary, is from the branches to the trunk, from whence it finds its way back to the heart. The arteries, moreover, are of less calibre than the veins, and consequently the blood flows in them with greater velocity. The greater arteries are accompanied by a greyish flexible cord, which can be perceived, but not without some attention; it passes along the sides of the artery: this cord is only a nerve.

As the ramifications of the arteries are multiplied they are diminished in calibre, and merge at length in the capillaries, from which they are scarcely distinguishable, the latter being equally indistinguishable from the smaller veins. As these conduits of the blood diminish in diameter, the red corpuscles at length so completely fill them, that they can only move in them one by one, and they can be thus seen following one another at perceptible intervals. If the microscope be directed to that part of the edge of the tongue, which is within the limits of the hole made in the

## MICROSCOPIC VIEW OF MILK.

cork, the blood can be traced in its course to the extreme arteries, and thence from the smaller to the larger veins on its return to the heart.

84. The vascular system of the tongue appears traced upon a greyish semi-transparent brown, on which a multitude of fine fibres, *v v*, are seen extended in different directions; these existing at different depths within the thickness of the tongue, appear superposed and interlaced; these fibres belong to the muscle of the organ, and their characteristic action is rendered evident in the microscope, by their alternate contraction and extension. A number of greyish spots, somewhat round in their outline and a little more opaque than the neighbouring parts, appear scattered through the tongue; these spots belong to the mucous-membrane, and are in fact parts of the glands in which saliva is secreted. They are the theatres of a surprisingly complicated and active blood-motion. The sanguine fluid enters them at one side, generally by a single small artery, rarely by two, and following the course of this artery, it pursues a nodulated path, resembling the form of a bow of ribbon, or the figure 8, and issues from them at a point opposite to that it entered. The organ of which we speak, says Dr. Donné, having a certain thickness, we cannot always see at once the entrance and departure of the blood, the point of its departure being often in a plane inferior or superior to that of its entrance, and the two points not being, therefore, at the same time in focus. But in any case, nothing can be more curious or more profoundly interesting than the vortices of rapid circulation, thus exhibited, in a space so circumscribed and within the limits of an organ, which is evidently one of secretion.

85. These greyish spots in short, in which the circulation proves to be so active, are nothing but the mucous-follicles of the tongue, the little glands in which is secreted the viscous humour which coats in such abundance the tongue of the frog, and we accordingly find that if it be wiped off, it will be almost immediately reproduced.

86. The milk of mammalia being the first nourishment taken by their young, and their only nourishment until a certain epoch of their growth, it might naturally be expected that that fluid would have a close analogy to the blood. The examination of milk accordingly, whether with the microscope or by means of chemical analysis, proves such an anticipation to be well-founded. If a small drop of milk be laid upon a clean slip of glass, and covered by a thin film of glass, so that a thin stratum of the fluid shall be included between them, it is found on submitting it to the microscope, in the same manner as has already been described

## MICROSCOPIC DRAWING AND ENGRAVING.

in the case of the blood, that very similar appearances are presented. A multitude of minute pearly spherules with the most perfect outline, reflecting light brilliantly from their centre and varying in magnitude from the 12500th to the 3000th part of an inch in diameter, and even larger still, are seen floating in the fluid.

The general magnitude and number of these globules vary much, not only in the case of one species of animal compared with another, but with different individuals of the same species, and even with the same individual under different circumstances.

87. In fig. 40, p. 97, we have given the appearance presented by a thin disc, the 120th of an inch in diameter, of common cow's milk magnified 400 times in its linear, and therefore 160000 times in its superficial dimensions, engraved from a daguerreotype by MM. Donné and Foucault.

88. It appears from the researches of physiologists on this subject that the pearl-like globules, which thus float in such multitudes in milk are the constituents out of which butter is formed. The serous fluid in which they float is composed of the constituent out of which cheese is formed, combined with another substance called sugar-of-milk, and water, the last constituting from 80 to 90 per cent. of the whole, so that, in fine, milk in general may be regarded as water holding in solution the substances called sugar-of-milk and caseine, the name given to the cheesy principle, with the globules of butter already described floating in it.

89. The proportion in which these constituents enter into the composition of milk varies, the richness always depending on the proportion of globules of butter contained in it.

90. The following is an analysis of the milk of the woman, the cow, the goat, and the ass, according to Meggenhofen, Van-Stiptrian, Liuscius, Bonpt, and Péligot:—

	Woman.	Cow.	Goat.	Ass.
Butter . . . . .	8·97	2·68	4·56	1·29
Sugar of Milk . . . . .	1·20	5·68	9·12	6·29
Cheesy matter . . . . .	1·93	8·95	4·38	1·95
Water . . . . .	87·90	82·69	81·94	90·47
	<hr style="width: 50%; margin: 0 auto;"/>	<hr style="width: 50%; margin: 0 auto;"/>	<hr style="width: 50%; margin: 0 auto;"/>	<hr style="width: 50%; margin: 0 auto;"/>
	100·00	100·00	100·00	100·00

91. From this and similar analyses it appears that woman's milk is by far the richest of the mammalia, containing generally little short of 10 per cent. of butter, while the milk of other species contains no more than from 1 to 4 per cent. of that principle.

It must, however, be observed that these are average proportions,

## CONSTITUTION OF MILK.

and that the richness of the milk differs considerably in different individuals. It is found that in all cases the milk is sufficiently rich in the cheesy principle, the constituent in which it fails being the butter, which is the most important in respect to nutriment.

The butter globules of woman's milk, though much greater in quantity, as appears above, than those in the milk of inferior animals, appear from the observations of Dr. Donn  to be smaller in magnitude. We have given in fig. 43, the appearance

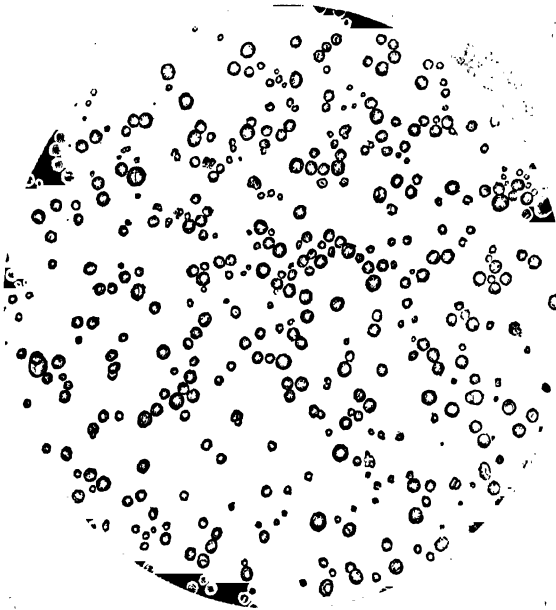

fig. 43.—THIN DISC OF WOMAN'S MILK, THE 120TH OF AN INCH IN DIAMETER, MAGNIFIED 400 TIMES IN ITS LINEAR, AND 160000 TIMES IN ITS SUPERFICIAL DIMENSIONS.

of a disc of ordinary woman's milk, magnified similarly to fig. 40. The difference between the magnitude of the globules is apparent.

92. The analogy of milk to blood manifested in a manner so striking by the microscope, was still farther investigated in a series of highly interesting experiments made by Dr. Donn .

## MICROSCOPIC DRAWING AND ENGRAVING.

That eminent physiologist transfused milk into the blood vessels of various animals, with all the precautions necessary to prevent the admission of air. It was found generally that the vital functions of the animal, were neither interrupted nor disturbed; the milk mingled with the blood and circulated with it through the system, its presence being detected in all the vessels. But the most interesting and important result of these researches, was, that the butter globules of the milk were found to assimilate themselves to, and play the same part with, the white globules of the blood, and like them were gradually converted into red corpuscles, and it appeared that the place where this change was elaborated was, as in the case of the white corpuscles of the blood, the spleen.

These researches and their results, however, being recent and novel, must be received with that caution which is always necessary in physical researches, until they are repeated and like results reproduced by other observers.

93. The question of the quality of milk in respect to its richness, has high sanitary and economic importance, and yet it is one which hitherto does not appear to have received the attention which it merits. We hear on all hands the adulteration of milk complained of, and the frauds of the milkman reprehended; but we seldom hear of any practical methods applied for the purpose of detecting and checking this abuse. It will perhaps not be out of place here, to say a few words in illustration of this question.

94. The richness of milk, as has been just observed, depends on the proportion of butter globules which it contains; these globules being lighter, bulk for bulk, than the liquid in which they float, have a tendency to rise to the surface, and when milk is allowed to stand still they do rise to the surface, where, mixed with a certain portion of the cheesy principle and sugar-of-milk, they form cream. Now it follows, that being thus lighter, bulk for bulk, than the fluid in which they float, they have a tendency, when mixed with that fluid, as they are when the milk is in its natural state, to render the milk lighter, and the larger the proportion is in which these butter globules are mixed with the milk, the lighter will be the milk. It was therefore inferred, that the lightness of the milk might be taken as a test of its richness, and M. Quévenne invented a species of hydrometer, which he proposed to apply to test the richness of milk, in the same manner as the ordinary hydrometer is applied to test the strength of spirits. But the indications of this instrument, ingenious as it is, are fallacious.

95. Let us suppose that the fraudulent milkman allowing the

## ADULTERATION OF MILK—LACTOSCOPE.

milk he proposes to sell, to stand until the richer portion forms a creamy stratum at its surface, then skims off this stratum which he sells at a high price, as cream. The remainder and impoverished portion of the milk is then undoubtedly heavier than before it was deprived of the cream, and its poverty would be detected by Quévenne's hydrometer: but the crafty milkman, aware of this, has the adroitness, not only to correct the too great weight of the fluid, but to do so to his own increased profit. He knows that the addition of water will diminish the specific gravity of his skimmed milk, and he accordingly mixes with it just so much of that cheap liquid as will reduce its weight to that of milk of the proper richness.

96. This manœuvre is attended also with another deceptive effect; it is found that the mixture of water with milk facilitates the disengagement of cream, and expedites its collection at the surface. Whatever creamy particles, therefore, may remain in the milk thus impoverished and adulterated, will rise quickly to the surface, and collecting there, will deceive the consumer, producing the impression that the milk on which cream so quickly collects, must necessarily be rich.

The great importance of discovering such an easy and practicable test of the quality of an element so important to the sanitary condition of the people, as milk, ought, one should have supposed, to stimulate scientific men to such an invention. The frauds practised so extensively by the vendors of milk on great public establishments, such as hospitals and schools, are notorious. An eminent medical practitioner says, that in conversing with one of the great milk contractors of the public establishments in Paris, during a season in which forage had risen to a very high price, the milkman observed frankly, and with a smile, "in common seasons, we do put a little water to the milk, but at present we are obliged to put milk to the water."

97. Dr. Donné has invented an instrument to ascertain the richness of milk, which he calls a *lactoscope*, which was presented to the Academy of Sciences, and favourably reported upon by a committee consisting of MM. Thénard, Chevreul, Boussingault, Regnault et Séguier, who experimented with it and verified its results. This instrument is based upon the fact, that while the butter globules, which float in milk, are opaque, the liquid which surrounds them is nearly transparent. It follows from this, that the transparency of milk will diminish as its richness increases, and *vice versa*.

The lactoscope consists of two plates of glass, set parallel to each other, so as to form a cell in the end of a tube, like an opera-glass, the cell being at the wide end of the tube. A screw-



## MICROSCOPIC DRAWING AND ENGRAVING.

adjustment is provided, by which the distance between the plates of glass may be varied within certain limits, so that by turning the screw in one way, the plates may be brought into absolute contact, and by turning it the other way, they may be separated by any desired interval. Over this cell, is provided a small cup, with a hole in its bottom, by means of which the cell may be filled with milk. Let us now suppose this cup to be filled with the milk to be tested, the screw having been previously turned until the plates of glass composing the cell are in contact. The milk in that case, will not pass between them, but will remain in the cup. Let the observer, applying his eye to the small end of the instrument, look through the cell at the flame of a candle, placed at about three feet distance from it, and let him at the same time slowly turn the screw, so as to let the milk flow into the cell; at first the candle will be seen dimly through the milk, but when the plates have been separated by the screw to a certain distance, the flame will be no longer visible, being intercepted by the multitude of butter globules in the milk.

Now it will be found, as may be expected from what has been explained, that the poorer the milk is, the greater will be the distance to which the glasses must be separated in order to intercept the flame, and the richer it is, on the other hand, the less will be the distance which will suffice to produce that effect.

These instruments are made and sold by the Paris opticians.

98: It may be objected that the certainty of this instrument depends upon the fact that the milk is impoverished either by skimming it or by mixing it with water, but that if it be adulterated by any substance which will promote its opacity, the indications of the instrument must fail. The answer to this objection is, that such a mode of adulteration is impracticable; the substance used for such a fraudulent purpose must in the first place be one, which, when mixed with the milk, will not sensibly alter its conspicuous and well-known properties, such as its colour, taste, odour, and general consistency. It must, moreover, be soluble in the milk, and not merely mixed with it, since if so, it would either sink to the bottom, forming a sediment, or rise to the top, as oil would in water, and in either case, would be immediately detected. It must also be such as will not be disengaged by heat, and thereby be betrayed in boiling the milk: in fine, it must obviously be a substance cheaper than milk, and the process of combination must be so simple as to be inexpensive and to admit of a certain secrecy; now it is quite apparent, that there is one substance only which will fulfil all these conditions, and that substance is water.

99. The frauds practised by the vendors of milk do not always

## FRAUDS OF MILK SELLERS.

consist in adulteration ; we have already mentioned the case of skimming the milk, and selling the richer and poorer portions at different prices ; this cannot be characterised as fraud, so long as the difference of quality is admitted, but yet it has the effect of fraud upon the consumer of the skimmed portion, for the milk he obtains is precisely the same in quality as he would obtain if the milkman instead of skimming the milk had left it in its natural state, but watered it, so as to reduce it to the poverty of skimmed milk.

100. There is another expedient, commonly enough practised, which is attended with similar effects, when the milk is allowed to accumulate in the breasts or dugs of the animal until they become filled and distended, the first portion drawn from them will be poor, and the milk will become richer and richer until the vessels are emptied. This physiological fact is quite familiar to dairymen, who divide the milking of the cow into two parts, the fore-milk and the after-milk ; the latter being sometimes called *strippings*. Now this richer portion of the milk is often reserved for cream, the fore-milk only being sold to the consumer. In accordance with the same principles it will be easily understood, that the more frequently the animal is milked, the more uniformly rich will be the fluid.

All the circumstances here explained, and the tests provided, to ascertain the quality of the milk of inferior animals, are equally applicable to human milk. Wet-nurses differ one from another evidently enough in the abundance of their milk, and this is a point which, accordingly, is never overlooked in the selection of nurses. The quality of the milk, however, being much less obvious, is rarely attended to. Yet it is even more important than the mere question of quantity. The physical researches of some of the French physiologists have shown that cases frequently occur in which there is a superabundance of milk ; and where, though the woman presents the aspect of health and vigour, the milk is poor in butter, the globules being small either in magnitude or number, or both ; they are sometimes observed to be ill-formed, to float in a liquid of little density, and sometimes to be mixed with corpuscles of mucus and of a granular substance. These are characters incompatible with the healthiness of the milk, yet they are such as can only be detected by the microscope. Nevertheless, it is rare indeed that the medical practitioner ever thinks of instituting such inquiries, much less of resorting to the microscope or any other lactoscopic test.

101. We have now indicated, so far as we are informed, all the methods by which the representations of microscopic objects are obtained, and of these that which gives the strongest guarantee of

## MICROSCOPIC DRAWING AND ENGRAVING.

accuracy and fidelity is the photographic method. It must, however, be observed, that even in this method, as it was practised in the production of the Microscopic Atlas of Messrs. Donné and Foucault, there is still a possible source of inaccuracy remaining, the engraver having to reproduce the photographic picture upon his plate, and for the fidelity of this process, there is no other guarantee than the general accuracy of the engraver's art.

Measures are, however, now being taken, with a fair prospect of success, by which an optical picture being projected upon a plate, will engrave itself—an approach to this has indeed been made; the photographic picture being projected upon a surface of wood, properly prepared and being there delineated by its own light, as it would be on a daguerreotype plate. The engraver after this has nothing to do but to follow the lines of the picture with his graving tool.

Attempts, however, are being made to cause the light itself to engrave the plate, and I have seen microscopic pictures of the blood corpuscles thus self engraved, which, if not completely satisfactory as works of art, have been sufficient to impress me with the conviction, that we are not far from the attainment of a measure of such high scientific importance as that of making natural objects engrave themselves.



LONDON ENTRANCE TO THE LONDON AND NORTH-WESTERN RAILROAD.

## THE LOCOMOTIVE.

### CHAPTER I.

1. Familiar to every eye.—2. Its mechanism not generally understood.—3. Object of this Treatise.—4. Two modes of propelling wheel carriages.—5. How locomotive is propelled.—6. Action of piston-rod on wheels.—7. Dead points.—8. Unequal action.—9. How remedied.—10. Connection of piston-rods with wheels.—11. Wheels fixed on their axles.—12. Form of locomotive.—13. Driving-wheels.—14. Coupled wheels.—15. Consumption of steam.—16. Evaporating power of boiler determines efficacy of engine.—17. Fire-box.—18. Tubes through boiler.—19. Fuel.—20. Blast-pipe.—21. Tender.—22. Plans and sections, with their description.

1. ALTHOUGH it be the variety of the steam-engine, whose invention is the most recent in date, the locomotive is the form of the machine which is most familiar to the public in every country. To behold the vast engines used for drainage, mining countries

## THE LOCOMOTIVE.

must be visited ; to see those adapted to useful machinery, we must go to the factories ; to view those applied to navigation, we must descend into the holds of ships. The locomotive, however, needs not be sought. It is patent and obtrusive. It addresses the senses of hearing and seeing. The warning whistle and the snorting chimney are familiar to every ear, and the flashing speed of the engine, with its snake-like appendage of vehicles of transport, is familiar to every eye.

2. Of the countless multitudes in all civilised countries who witness the extraordinary performances of the locomotive, and participate in its use and enjoyment, few comprehend the source of its power, or the principle of its action. They see it sweep along with the speed of the hurricane, drawing after it carriages, carrying hundreds of human beings, or hundreds of head of cattle, or tons of goods, but the agency which accomplishes this miracle is to them wrapt in mystery. Many desire to possess the key to the enigma, to unlock the secret, but recoil from the labours which the perusal and study of even the most popular treatise on the locomotive would require, a labour for which few have the disposable time, and still fewer the qualifications depending on preliminary knowledge and intellectual aptitude.

3. It is this multitude that we now desire to address, hoping to offer, in a small compass, such a simple and clear account of the variety of steam-engine referred to, as will be intelligible to all persons, without more labour than all can conveniently devote to it.

4. A moving power may be applied in two ways to propel a vehicle supported on wheels. It may be harnessed to it as horses to a carriage, and may draw it on by traces, or it may be applied to the wheels, so as to make them revolve. If the wheels be made to revolve, they must either slip upon the road, or the vehicle must advance. But if the weight upon them be considerable, and the state of the road suitable, they will have such adhesion with the road at the points where they rest upon it, that they will not in general slip ; and if they do not, the vehicle which they support must be propelled by each revolution of the wheels through a space equal to the external circumference of their tires.

5. Now it is by this latter means that the power of steam is applied to propel the locomotive. The steam pistons are connected by iron rods, called connecting-rods, either with the spokes of the wheels, at certain regulated distances from the axles, or with arms, called cranks, formed on the axles between the wheels. The force with which the pistons are alternately driven by the steam from end to end of the cylinders, is conveyed by the connecting rods to the spokes or cranks, and it acts upon them in the

## ACTION OF PISTON ON WHEELS.

same manner as the arm of a man acts upon a windlass, thus imparting a continuous motion of revolution to the wheels.

6. To render this action of the piston on the wheels more apparent, the piston-rod, the connecting-rod, and the spoke or crank, are shown in fig. 1, in eight successive positions assumed by them during each revolution of the crank. The direction in which the connecting-rod acts upon the crank is indicated by the arrow.

The joint  $p$  unites the connecting-rod with the end of the piston-rod, and the joint  $r$  unites it with the end of the crank or spoke, the fixed centre round which the crank or spoke revolves being  $c$ .

While the piston makes a double stroke from one end of the cylinder to the other and back, the joint  $r$  makes one complete revolution round the centre  $c$ .

In the position shown in A, the piston is at the end of the cylinder most remote from the crank, and the joint  $r$  is directly between the centre  $c$  and the joint  $p$ .

In the position B, the joint  $r$  has moved from that position, the piston moving towards  $c$ , and the connecting-rod and crank forming an obtuse angle. The force of the steam impelling the connecting-rod in the direction shown by the arrow, acts at an obtuse angle with the crank.

As the piston continues to move, the angle formed by the connecting-rod and crank becomes less and less, until in the position shown in C the angle becomes a right angle, and then the whole force given to the connecting-rod becomes effective.

In the position D, the angle formed by the connecting rod and crank becomes acute, and in the position E, the joint  $r$  assumes a position in a direct line with  $c$  and  $p$ , and the piston has reached

Fig. 1.

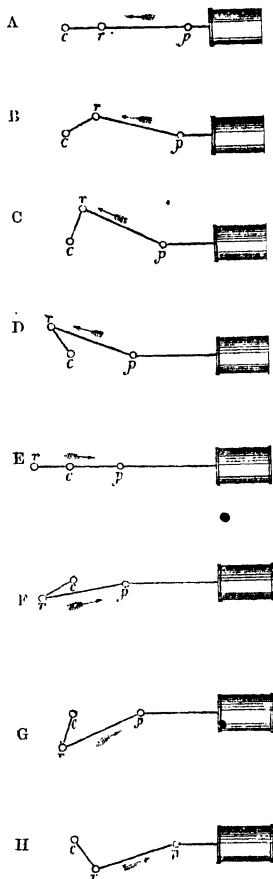

## THE LOCOMOTIVE.

the end of the cylinder nearest to *c*. After this the piston begins to move from *c* towards the more remote end of the cylinder, and the joint *r* assumes successively the positions shown in *F*, *G*, and *H*, the crank making first an acute angle, then a right angle, and, in fine, an obtuse angle with the connecting-rod, until the piston has arrived at the more remote end of the cylinder, when the points *c*, *r*, and *p*, receive the position shown in *A*.

7. It must be observed, that in the positions shown in *A* and *E*, the connecting-rod being parallel to the crank, can have no power to turn it; that in passing from the position *A* to the position *c*, the rod being less and less oblique to the crank, has a continually increasing power to turn it, until at *c*, being at right angles to it, it has full power upon it. After passing the position *c*, the rod becoming more and more oblique to *c*, has less and less power upon it, until arriving at the position *E*, it is parallel with it, and loses all power over it.

The two positions shown in *A* and *E*, in which the piston is at one end or the other of the cylinder, and in which the piston loses all power to move the crank, are called the DEAD POINTS.

8. After passing the position *E*, when the piston, having changed the direction of its motion begins to return to the other end of the cylinder, the rod again forms an acute angle with the crank, and acts upon it, but with disadvantage, as shown in *F*.

The angle formed by the rod and the crank increasing, becomes at length a right angle, as in *G*, when the rod acts with full effect on the crank.

After this, the angle between the rod and the crank becomes obtuse, as in *H*, and the action is again disadvantageous, and more and more so as the angle becomes more and more obtuse, until at length the rod and crank return to the position represented in *A*.

Since the action of the piston upon the wheel is, therefore, unequal, having its greatest efficiency at the points shown in *c* and *g*, and ceasing altogether in the positions *A* and *E*, a single piston would give to the engine an unequal progressive motion. It would advance by starts, being impelled with most effect when the piston has the positions *c* and *g*, and moving only in virtue of the velocity already imparted to it when the piston is at the dead points *A* and *E*. The motion would be alternately fast and slow, according to the varying position of the connecting-rod and crank.

9. This inequality is effaced, and an uniform motion obtained by using two cylinders driving different cranks or different wheels, and so arranging them, that when either is at its dead points, the other is in its positions of greatest efficiency. This is accomplished simply by placing the two cranks at right angles to each other, or

## CRANKED AXLE.

by connecting the rods with spokes at right angles to each other. By such an arrangement, the combined effects of the two cranks will be invariable, or nearly so, the effect of either increasing exactly as that of the other decreases.

10. The cylinders are sometimes placed between and sometimes outside the wheels.

If they are placed between one pair of wheels the axle of another pair is formed with two cranks, placed at right angles to each, which are worked by the connecting-rods of the pistons.

Such a double-cranked axle is shown in fig. 2, the cranks being seen in a position oblique to the plane of the diagram. The connecting-rods are understood to be attached to the cranks at *b*, and the wheels, which are to be driven, are keyed upon the extremity of the axle at *a*.

When the cylinders are placed outside the wheels, the connecting-rods are attached to two spokes, one upon each of the wheels which they are intended to drive, these two spokes being in positions at right angles to each other, and the wheels being keyed upon the axles, so that the wheels and axles turn together.

11. It may be stated generally that the wheels of railway vehicles and engines do not turn upon their axles like those of common road carriages, but are always fixed upon the axles, so that the wheel and axle turn together, and, consequently, whether the force of the connecting-rods act upon the spokes of the wheels, or upon cranks formed upon the axle, they will be equally efficient in imparting rotation to the wheels and consequently impelling the engine.

12. The locomotive engine is commonly supported on three pairs of wheels. In some cases of small and light engines there are only two pairs, and in others there are four pairs.

The general form and disposition of the parts of a locomotive upon three pairs of wheels is shown in fig. 3. In this case the two cylinders are placed immediately in front of the fore wheels and under the chimney. The intermediate pair of wheels are driven by the connecting-rods.

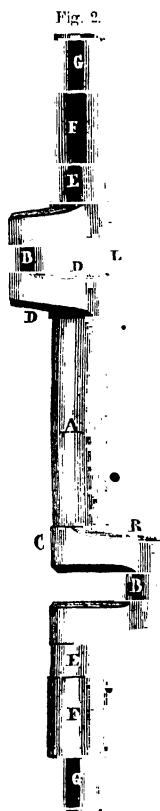



## THE LOCOMOTIVE.

13. The pair of wheels to which revolution is imparted by the piston-rod, through the intervention of the connecting-rods, are

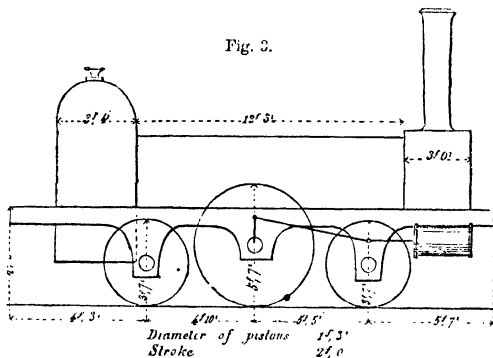

called the **DRIVING-WHEELS**, since it is by their immediate action that the engine draws the train which is attached to it. They are generally of greater diameter than the supporting-wheels, in order that the engine may be propelled through a greater space by each stroke of the piston, since the space through which it moves by each double stroke is equal to the circumference of the driving-wheels.

The actual dimensions of such an engine as is represented, are indicated on the diagram.

In some engines of more recent construction the driving-wheels are placed in the hindermost part of the engine, the cylinders

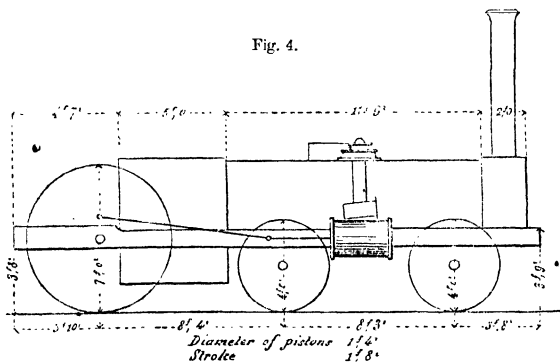

being between the intermediate and foremost pairs of wheels, as

## DIFFERENT FORMS OF LOCOMOTIVES.

represented in fig. 4. In these the driving-wheels are of greater dimensions, and the engine is adapted to attain greater speed.

A lighter and less powerful class of locomotive, supported on two pairs of wheels, is shown in fig. 5, the hinder pair being the driving-wheels.

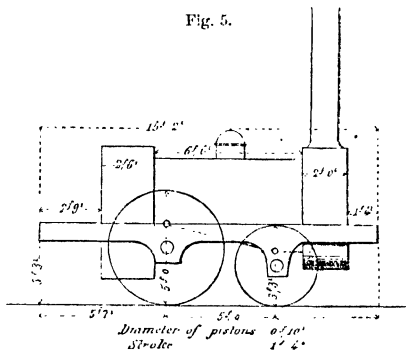

14. When locomotives are intended to draw very heavy loads with less speed, as in the case of goods engines, the driving-wheels have less dimensions, and, in order to give them a greater hold upon the rails, it is usual to connect two pair of side wheels, of exactly equal dimensions, so that the piston shall act at once on both by means of the connecting-rods. The two pair of driving-wheels thus connected are said to be **COUPLED**, and the engine is

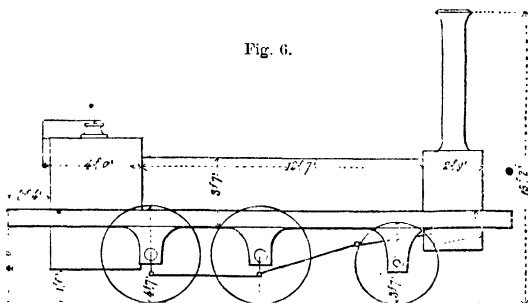

called a coupled-engine. Such an engine is shown in fig. 6, where the hinder and intermediate pairs are coupled, the connect-

## THE LOCOMOTIVE.

ing-rods being attached to the intermediate pair, and through them acting also on the hinder pair.

15. It has been shown that to give a revolution to the driving-wheels, each of the pistons must move once backwards and forwards in the cylinder, and consequently the boiler must supply to the cylinders four measures of steam. In this way, the consumption of steam necessary for a given progressive speed of the carriage may be calculated. Thus, if the circumference of the driving-wheels be thirty feet, four cylinders full of steam will be consumed for each thirty feet through which the carriage advances. It is apparent, therefore, that the ability of the engine to move the load with any requisite speed is resolved into the power of the boiler to produce steam of the requisite pressure at this required rate.

Let it be supposed that it is desired to transport a certain load at the rate of thirty miles an hour, which is at the rate of half a mile, or 2640 feet per minute. Let the circumference of the driving-wheels be twenty-six feet and four-tenths. These wheels will revolve one hundred times in moving over 2640 feet, or half a mile, that is to say, one hundred times per minute. But since each revolution requires the boiler to supply four cylinders full of steam, the consumption of steam per minute will be four hundred times the contents of the cylinder.

16. The pressure of the steam will depend upon the resistance of the load. By the common principles of mechanics, the power acting upon the pistons necessary to balance a given resistance at the circumference of the wheel can be easily calculated, and thus the necessary pressure of the steam ascertained. In this manner it can always be determined how much steam, of a given pressure, the boiler must produce, in order to enable the engine to carry a given load with any required speed.

The mechanism being properly constructed, it follows, therefore, that the efficacy of the engine must depend ultimately on the evaporating power of the boiler.

In the case of the locomotive engine there are particular conditions which limit the magnitude and weight of the machinery, and create impediments and difficulties in the construction of the machine, which are not encountered in stationary engines. As the engine itself is transported, and travels with its load, it must necessarily be subject to narrow limits as to weight and bulk. It has to pass under bridges, and through tunnels, which circumstance not only limits its general magnitude, but almost deprives it of the appendage of a chimney, so indispensable to the efficiency of stationary steam-engines.

It follows that this limitation of weight and bulk can only be

## EVAPORATING POWER—FURNACE.

rendered compatible with great power of evaporation by expedients which shall produce, in a small furnace, an extremely intense combustion, and which shall ensure the transmission to the water completely, and immediately, of the heat developed in such combustion.

17. The heat developed in the combustion of fuel in a furnace is propagated in two ways. A part radiates from the vivid fuel in the manner, and according to nearly the same laws which govern the radiation of light. These rays of heat, diverging in every direction from burning fuel, strike upon all the surfaces which surround the furnace. Now, as it is essential that they should be transmitted immediately to the water in the boiler, it follows that the furnace ought to be surrounded on every side with a portion of the boiler containing water; in short, a hollow casing of metal, filled with water, ought to surround the fire-place. By this expedient, the heat radiating from the fuel, striking upon the metal which forms the inner surface of such casing, will enter the water, and become efficient in producing evaporation.

Whatever then be the particular form given to the engine, the furnace must be surrounded by such a casing. This casing is called the FIRE-BOX. The bottom of it is occupied by a grate, which should consist of bars sufficiently deep to prevent them from being fused by the fuel which rests upon them, having sufficient space between them to allow the air to enter so freely as to sustain the combustion, but not such as to allow the unburned fuel to fall through them. •

18. The limited magnitude of locomotive boilers renders the construction of the extensive flues used in stationary boilers impracticable; and accordingly, in the early engines, a great waste of heat was occasioned, owing to the flame and heated air being permitted to issue into the chimney before their temperature was sufficiently reduced by contact with the flues.

At length an admirable expedient was adopted which completely attained the desired end. The boiler was traversed by a considerable number of small tubes of brass or copper, running parallel to each other from end to end, the furnace being at one end of the boiler, and the chimney at the other. The flame and heated air which passed from the furnace had no other issue to the chimney except through these tubes. It was thus driven, in a multitude of threads, through the water. The magnitude and number of the tubes was so regulated, that when the air arrived at the chimney, it had given out as much of its heat as was practicable to the water.

The full importance of this expedient was not appreciated until

## THE LOCOMOTIVE.

long after its first adoption. In the first instance, the tubes traversing the boiler were small in number, and considerable in diameter, but as their effects were rendered more and more evident by experience, their diameter was diminished and their number increased, and at length it was not uncommon for the boiler to be traversed by one hundred and fifty tubes of one inch and a half in internal diameter.

The heat was thus, as it were, strained out of the air before the latter was dismissed into the chimney.

These tubes were necessarily kept below the surface of the water in the boiler, so that they were constantly washed by the water, and the heat taken up from them was absorbed immediately by the bubbles of steam generated at their surface, which bubbles continually rose to the top of the boiler and collected in the steam chamber.

It will be understood from these observations, that the evaporating power of the locomotive boiler, is determined by the quantity of surface exposed to the radiant heat in the fire-box and the quantity of surface exposed to the action of the heated air in the tubes. The expression of the quantity of this surface in square feet is the usual test of the evaporating power of the boiler.

19. Much of the efficacy of these boilers depends on the quality of the fuel. As the engines travel through districts of the country more or less populous, the evolution of smoke is inadmissible in consequence of the nuisance it would produce. It was, therefore, resolved to use coke as fuel instead of coal.

Another advantage, however, attended the use of this fuel. Coke being composed chiefly of carbon, to the exclusion of the more volatile constituents of coal which produce flame in the combustion, the chief part of the heat developed acts by radiation. No flame issues from the furnace, and heated air only passes through the tubes. It is more easy, therefore, to extract the heat than would be the case if flame were developed. In short, with this fuel, the portion of the heat developed in the furnace is much greater than that which would be developed in the combustion of coal. The surface of the fire-box becomes relatively more efficient, and the flues less so than in stationary engines where coal is used.

Independently, therefore, of the advantage of developing no smoke, the coke is a form of fuel better adapted to the condition of the locomotive engine.

20. To sustain a rapid and intense combustion on a grate necessarily small, a proportional force of draft is indispensable. In stationary engines, as is well known, the draft in the furnace is usually produced by a chimney of corresponding elevation; but

## BLAST PIPE—FEED PUMPS.

this being inadmissible under the conditions of the locomotive engine, it is necessary to adopt some other expedient to produce the necessary current of air through the tube. A blower, or fanner, working in the funnel or in any other convenient position, would answer the purpose; but a much better expedient has been adopted.

The steam, after driving the piston, is allowed to escape, but in order to turn it to profitable account, instead of being dismissed into the atmosphere, where it would produce a cloud of vapour around the engine, it is conducted through a pipe to the base of the funnel, where it is allowed to escape in a jet directly up the chimney. In this manner a puff of waste steam escaping from the cylinders as the pistons arrive at the one end or the other, is injected into the chimney, and a constant succession of these puffs take place, four being made for every revolution of the driving-wheels. These continual puffs of vapour maintain in the chimney a constant current upwards, by which the air and gases of combustion are drawn from the fire-box through the tubes.

The pipe by which these jets are directed up the chimney, called the *blast-pipe*, serves the purpose of a most efficient bellows.

Those who are not familiar with steam machinery will not find it difficult to comprehend that a bellows would produce the same effect on the fire if it acted in the chimney, or even at the top of the chimney, as if it were applied at the grate bars, provided only that the mouth of the chimney near the fire be closed by a door, as it always is in steam-engines.

21. To keep the locomotive boiler supplied with water, and its furnace with fuel, it is accompanied by a carriage called a *tender*, which bears a supply of fuel, and a cistern of sufficient magnitude, containing water.

This cistern is connected with the interior of the boiler by pipes and force-pumps. The force-pumps are worked by the engine. The engineer is supplied with a lever, by which he can suspend the action of the pumps at pleasure; so that, if he finds the boiler becoming too full, he can, to use a technical phrase, "cut off the feed." Gauges are provided, by which he can at all times ascertain the quantity of water in the boiler, or, which is the same, the position of its surface. He is accompanied by a stoker or fireman, who from time to time opens the door of the fire-box and feeds the furnace.

22. This general description of a locomotive and its accessories, will be more clearly understood by the aid of diagrams, showing the principal sections and plans of an engine and tender.

A series of drawings, showing in section and elevation various

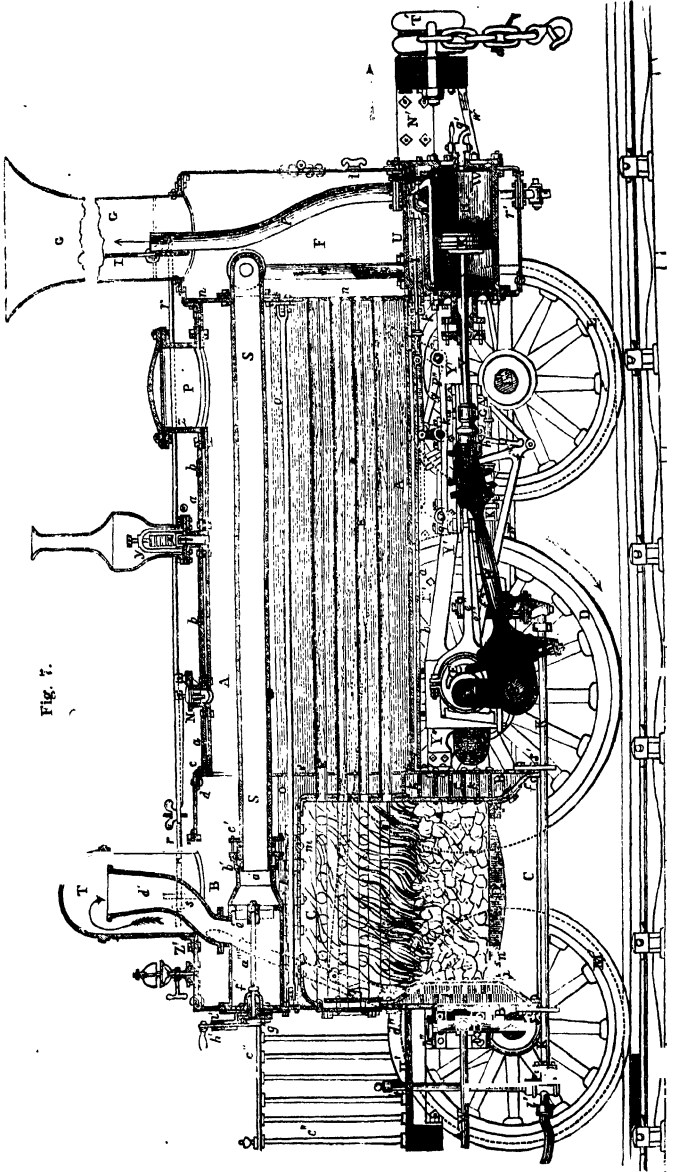
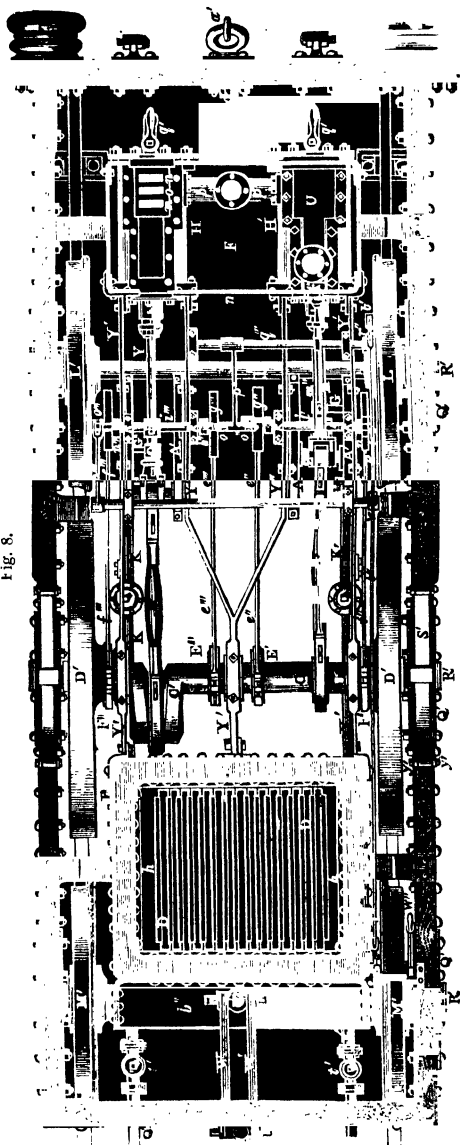

Fig. 7.

## PLANS AND SECTIONS OF ENGINE.

Fig. 8.



views of a locomotive engine on three pairs of wheels with its tender, is given in figs. 7, 8, 9, 10, 11, 12, 13, and 14.

Fig. 7 is a longitudinal vertical section, made by a plane parallel to the wheels, and passing through the axis of the boiler and the smoke-funnel.

Fig. 8 is a plane of the working machinery between the wheels and, beneath the boiler.

Fig. 9 is a transverse vertical section made by a plane passing through the fire-box at right angles to the wheels.

Fig. 10 is a similar transverse section, made by a plane passing through the smoke-box and the axis of the smoke-funnel.

Fig. 11 is an elevation of the end of the engine near the driver's stage.



## THE LOCOMOTIVE.

Fig. 12 is a similar elevation of the end next the smoke-funnel.

• Fig. 9.

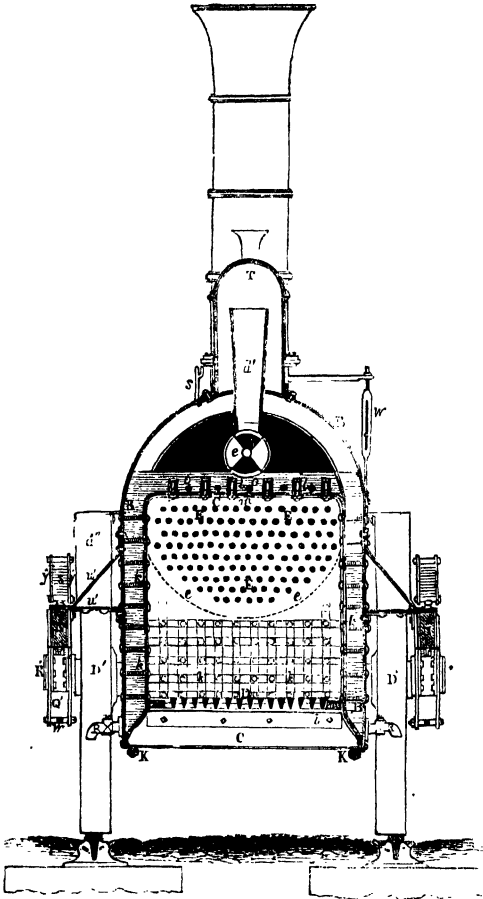

Fig. 13 is a longitudinal vertical section of the tender, by a plane at right angles to the wheels, and midway between them.

Fig. 14 is a plan of the tender seen from above.

The same parts in the different drawings are generally indicated by the same letters.

## PLANS AND SECTIONS.

The principal parts will be recognised by the preceding general description, and the following references:—

	Number of diagram.	Letters of reference.
The steam cylinders . . . . .	7, 8	H
The steam pistons . . . . .	7	X
The piston-rods . . . . .	7, 8	Y
The connecting-rods . . . . .	7, 8	B'
The cranks driven by them which in this case are constructed on the axle of the driving-wheels }	7, 8	C'
The driving-wheels . . . . .	7, 8, 9	D'
The supporting-wheels . . . . .	7, 8, 10, 11, 12	L, M
The passages to allow the entrance and escape of the steam to and from the cylinder . . . . .	8	<i>m, n, o</i>
The case containing the slide by which these passages are opened and closed . . . . .	8	U
Two pair of eccentrics by which the slides are moved, one governing the steam so as to move the engine forward, and the other so as to move it backward . . . . .	8	E' E'', F' F''
The rods by which these eccentrics act upon those of the slides . . . . .	8	<i>e' e''', f'' f'''</i>
The handle or lever by which the engine driver throws one or other pair of eccentrics into connexion with the slides . . . . .	7	<i>a'''</i>
The steam-chest, where dry steam free from mixture with aqueous spray is received from the boiler	7, 11	T
The steam-pipe leading from this chest by which steam flows to the slides and to the cylinder	7	S S
The blast-pipe, by which steam, after entering the piston, is discharged in puffs up the smoke- funnel . . . . .	7, 10	<i>v</i>
The fire-box containing the burning coke . . . . .	7, 9	C C
The hollow metal casing surrounding it secured by bolts and nuts, and filled with water . . . . .	7, 8, 9	<i>k k</i>
The grate bars forming the bottom of the fire-box	7, 8, 9	D
The fire door through which coke is put in from time to time to feed the furnace . . . . .	11	<i>g</i>
The tubes traversing the boiler longitudinally through which the hot gases of combustion and smoke pass from the fire-box to the smoke-box . . . . .	7, 9, 10	E E
The smoke-box at the base of the funnel, receiving the heated air from the tubes . . . . .	7, 8, 10	F
The smoke-funnel over the smoke-box and blast- pipe . . . . .	7, 10, 12	G
The regulator, by which more or less steam is allowed to pass along the steam-pipe, and by closing which the steam is altogether cut off from the cylinder . . . . .	7	<i>h'</i>
The stage upon which the engine driver and stoker stand . . . . .	7, 11	P' c''

## THE LOCOMOTIVE.

	Number of diagram.	Letters of reference.
The water gauge, being a glass tube communicating above and below with the interior of the boiler, in which the water stands at the same level as in the boiler . . . . .	11	L
Gauge-cocks, which serve a like purpose, one being below and the other above the proper level of the water. If the water be below the proper level, steam would issue from the lower, and if above it, water would issue from the upper cock . . . . .	11	M
The feed-pump, being a force-pump worked by the engine, by which water is forced into the boiler from time to time to replace that which is evaporated . . . . .	7, 8	K'
The feed-pipe, leading from the feed-cistern on the tender to the feed-pump . . . . .	7	K
The levers by which the engine driver governs the feed. These open or close the feed-pipe according as they are turned one way or the other. When the engine driver sees the level fall too low in the water gauge or by the gauge-cocks, he opens the feed-pipe by these cocks and puts on the feed, and when it has risen to the proper point he closes them. There are usually two feed-pumps, with their appendages . . . . .	11	l' l'
The smoke-box door, opening on hinges at the top by which that part of the engine may be cleaned . . . . .	12	z
The buffers, being circular cushions fixed upon the ends of strong iron rods, which re-act against spiral springs, to break the force in case of collision . . . . .	7, 12	T T'
The heads of the cylinders, which are secured by bolts and nuts, and can be taken off for the purpose of cleansing the ash-pit . . . . .	12	W W
The feeding cistern on the tender . . . . .	13, 14	I''
The feed-pipe proceeding from it . . . . .	13	P' Q''
The coupling of the parts of the feed-pipe attached to the engine and the tender . . . . .	13	P''
The coupling bar of the tender and engine . . . . .	13	W''
The coupling chain of tender and train . . . . .	13	Y''
The buffers of the tender . . . . .	13, 14	D''
The lids of the feed-cistern . . . . .	14	N''
The handle of the brake upon the tender . . . . .	14	X''
The space for coke . . . . .	14	B''

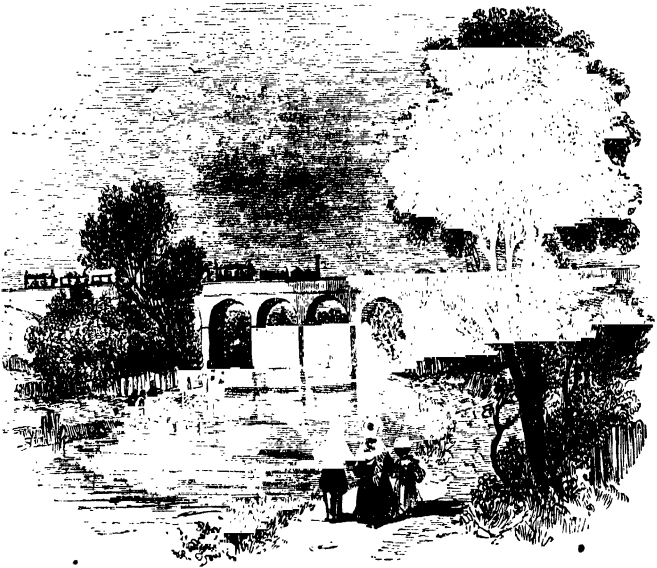

VIADUCT, NEAR WATFORD, LONDON AND NORTH-WESTERN RAIL-ROAD.

## THE LOCOMOTIVE.

### CHAPTER II.

23. Speed.—24. Locomotive stock.—25. What record of the performance and condition of an engine should be kept.—26. Cause of renewals of English locomotives.—27. Average mileage of engines.—28. Locomotive requires rest.—29. Expense of cleaning and lighting.—30. Reserve engines.—31. Bank engines.—32. Time they are kept standing.—33. Economy of fuel.—34. Register of consumption.—35. Small amount of useful service obtained.—36. On Belgian lines.—37. On other Continental lines.—38. On London and North Western line.—39. Comparisons between lines not fairly instituted.—40. Legitimate test of comparison.—41. Amount of locomotive stock required.—42. Gross receipts of European Railways in 1850.—43. Mileage of the same.—44. Great increase since.—45. Enormous consumption of coal.—46. Mileage of passengers and goods.

23. WHEN the extraordinary speed sometimes imparted to the loads drawn by locomotive engines on the English railways is considered, it will not be uninteresting to explain what operations

## THE LOCOMOTIVE.

the machinery of the engine must perform in order to accomplish such effects.

Let us take the example, not uncommon, of a train of coaches

Fig 10.

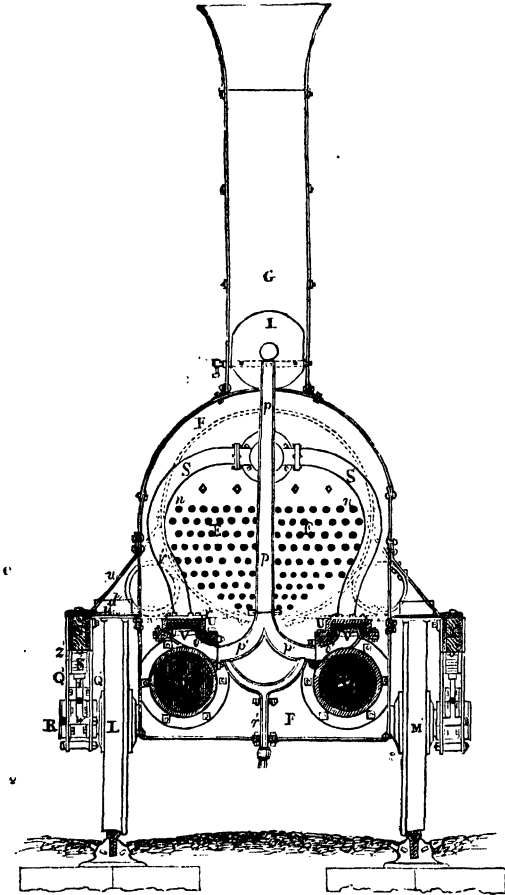

carried upon a railway, at a rate of sixty miles per hour. Assuming, as in a former example, that the circumference of the driving wheel measures  $26\frac{4}{10}$  feet, these wheels, as already explained, will revolve one hundred times in passing over half a mile, and there-

## OPERATION OF ENGINE.

fore two hundred times in passing over a mile. The speed of sixty miles an hour is that of a mile per minute. The driving wheels will, therefore, revolve two hundred times per minute. But it

Fig. 11.

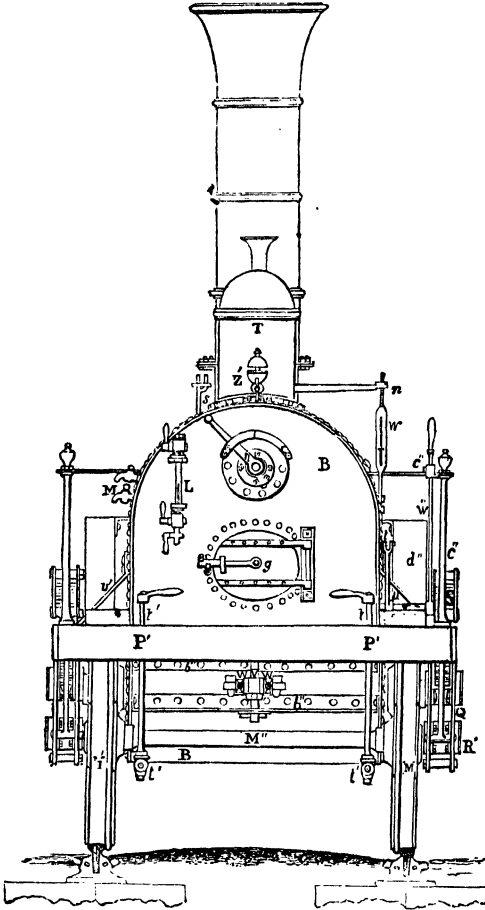

has been already explained that to produce one revolution of the wheels each piston is moved once backwards and forwards in each cylinder, and each cylinder must be twice filled with steam from

## THE LOCOMOTIVE.

the boiler, and that steam must be twice discharged from each cylinder through the blast pipe. It follows, that to accomplish the speed above mentioned, the boiler must supply to the cylinders

Fig. 12.

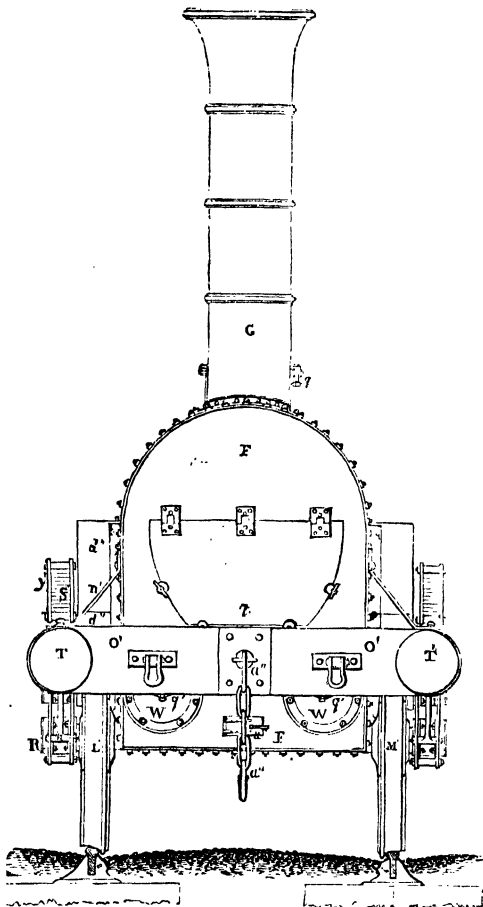

eight hundred measures of steam of the requisite pressure per minute. The valves which admit this steam to each cylinder must be opened four hundred times per minute, as must also both valves

## NECESSARY EVAPORATION.

by which the steam is ejected. The puffs from the blast-pipe must be made at the rate of eight hundred per minute.

If we assume that the contents of each cylinder is one cubic foot and a quarter, then the boiler must supply to the cylinder per minute 1000 cubic feet of steam. If this steam be assumed to have a pressure of 50 lbs. per square inch, then one cubic foot

Fig. 13.

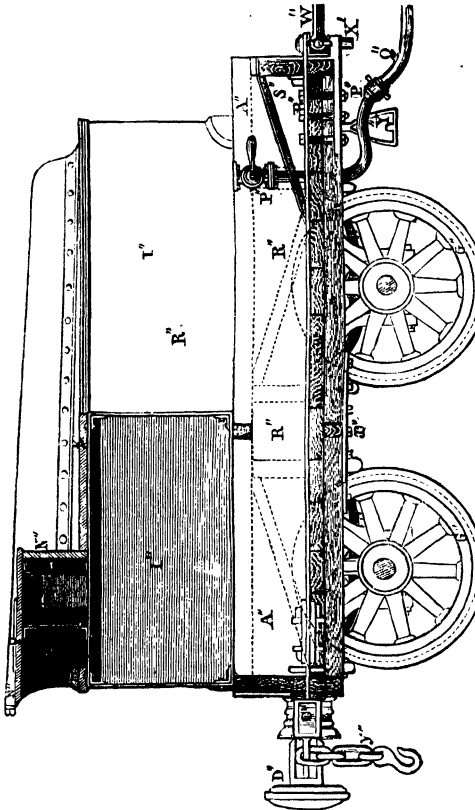

of water evaporated will produce about 500 cubic feet of such steam; and consequently, to supply 1000 cubic feet of steam per minute to the cylinders, the boiler must evaporate two cubic feet of water per minute, or 120 cubic feet per hour. This is a rate of evaporation which would correspond to a stationary boiler of a nominal power of 120 horses.



## THE LOCOMOTIVE.

24. When the magnitude of the capital invested in the locomotive stock of a railway, and the large proportion of the annual revenue absorbed in maintaining it are considered, its economical importance may be readily estimated.

The locomotive stock may be primarily resolved into two classes—that which is employed in working the passenger traffic, and that which is employed in drawing the goods trains.

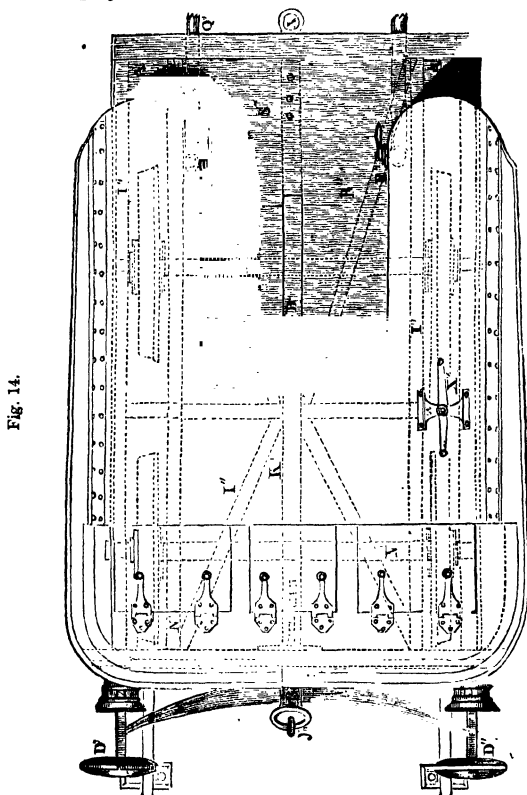

The passenger engines are so constructed as to draw light loads at great speed, the goods engines heavy loads at a low speed. In the one, the driving-wheels are large, so as to carry the train forward through a great space by each stroke of the piston; in the other, they are of more limited magnitude, in order to give the moving power a greater leverage upon the load. In the one, they

## LOCOMOTIVE REGISTER.

are single, rendering the engine light, so as to absorb less of the moving power in propelling itself; in the other, they are double and coupled, and sometimes even tripled, so as to give a greater purchase to the impelling power. In the one class of engine steam of small density is consumed rapidly and in great volume; in the other, steam of greater density is consumed at a slower rate.

These different mechanical requirements render it necessary, in general, to provide a locomotive stock for the goods service, separate from, and independent of, that provided for the passenger service.

25. In the locomotive department a register should be kept containing a record of the past and current performances and condition of every engine in the service of the railway. Such a record should contain the following particulars of the past services of each engine:—

- 1st. The day and year it was put upon the road.
- 2nd. Its maker.
- 3rd. The diameter and stroke of its cylinders.
- 4th. The diameter and number of its driving-wheels.
- 5th. The number of times it was cleaned, lighted, and had steam raised.
- 6th. The number of hours it was standing with steam raised.
- 7th. Its total mileage, from the commencement of its service to the current date.
- 8th. The total quantity of fuel it had consumed.
- 9th. Original cost of engine.
- 10th. Total sum expended on its repairs.

And, with respect to its current service during the past year, the following details should be given:—

- 1st. The number of times it was lighted, and had steam raised.
- 2nd. The number of hours it stood with steam raised.
- 3rd. Its mileage by months, and its total mileage.
- 4th. The quantity of fuel consumed in lighting and raising steam.
- 5th. The quantity of fuel consumed in standing.
- 6th. The quantity of fuel consumed in working.
- 7th. A memorandum of any accident, or other notable circumstance, attending the performance of the engine.

Such a record as the above is neither impracticable nor unimportant. A register of this kind is kept by the administration of the Belgian railways, and the principal results of it are published annually, in a tabulated form, in the "Compte Rendu," or official report of the service of the railways, delivered to the Chambers, by the Minister of Public Works every session. Such a table exhibits a "coup d'œil" of the condition and the past history of the entire locomotive stock.

## THE LOCOMOTIVE.

26. In the progress of the English railways, locomotives have been, from time to time, cast aside, and put, as it were, upon the retired list; but this has often arisen, not from the circumstance of their being superannuated, but because the conditions of the traffic had undergone such a change that the natural powers of these engines were not suited to it. Immediately after the commencement of the operation of the railway system, the traffic augmented so rapidly as to exceed all the provisions of those who constructed and organised the first railways. The weight and strength of the rails were successively increased, as well as the weight and magnitude of the trains, and the weight and power of the engines underwent a corresponding augmentation.

A regularly kept journal of the life of some of the oldest locomotives working on the English railways would be a record of profound interest. Whether such a register exists, I am not aware; but none such has, I believe, ever been published.

27. From a comparison of the total mileage of each class of the locomotive stock with the number of engines in service, the average mileage of each engine can be ascertained.

As an example of such a calculation, let us take the Belgian railways for 1847.

The total number of engines in active service was 154, and their total mileage was 2,366,885; this divided by 154 gives 15,369 as the average annual mileage of each engine, the average daily mileage being therefore 42 miles.

28. It may be asked, whether a locomotive engine, once lighted, may not be worked almost indefinitely?

It is known that many steam-engines used in the manufactures and in mining are kept for several months together in unceasing action night and day; and the engines used in steam-ships are often kept in incessant operation throughout a voyage of 3000 miles. Why therefore, it may be demanded, may not a locomotive engine be worked for a much longer distance without interruption, and thus distribute the expense of lighting and cleaning over a greater extent of mileage, and thereby diminish the cost per mile?

Although the mileage of the engine might be augmented much beyond its present amount, it is nevertheless indispensable that it should not exceed a certain practical limit. The locomotive engine, an iron horse, requires intervals of repose as much as do the horses of flesh, blood, and bones. It becomes fatigued, so to speak, with its work, and its joints become relaxed by labour, its bolts loosened, its rubbing surfaces heated, and often unequally expanded and strained. Its grate-bars and fire-box become choked with clinkers, its tubes become charged with coke; and were its labour continued

## RESERVE ENGINES.

to a certain point, it would end in a total inability to move. The durability of the engine, therefore, requires that its work should be suspended before these causes of disability operate to an injurious extent.

When its labour ceases, the engine-cleaners, who are, as it were, its grooms, clean out its fireplace, scrape its grate-bars and the internal surface of the fire-box, clean out its tubes, tighten all its bolts and rivets, oil and grease all its moving parts, and, in a word, put it again into working order.

29. The expense of cleaning an engine, and the cost of the fuel consumed in lighting it and raising the steam, so as to prepare it for propulsion, must necessarily be charged upon the mileage which it performs; and the cost of this mileage will therefore be augmented in the inverse proportion of the ratio of the total mileage of the engine to the number of times it has been cleaned and lighted during the period of its service. It is therefore important, in the economy of the locomotive power, to ascertain with precision the proportion which the mileage of the engines bears to the number of times they have been cleaned and lighted.

Hence appears the importance of the record above mentioned, of the number of times each engine has been lighted and cleaned.

To determine the average number of miles run by each engine after such cleaning and lighting, it is only necessary to divide the total mileage of the locomotive stock, or of each class of it, by the total number of engines lighted; the quotient will give the distance run by each engine lighted.

In the practical working of the locomotive stock, it inevitably happens that engines, after they have been lighted, had their steam raised and prepared for starting, have to stand, keeping their steam up more or less time, waiting for trains which they are to draw; and thus an expense is incurred, not directly productive, for fuel and wages.

30. But, besides this, the service of the road requires that, at certain stations, engines shall be kept waiting with their steam up ready for work, for the mere purpose of providing for the contingencies of the active service of the road. Thus, if an accident occur to a train, by which the engine that draws it is disabled, notice is sent forward by the electric telegraph, by signals or otherwise, to the next engine station, summoning an engine to proceed to the spot to take on the train. If an engine were not prepared for such a contingency, with its steam up, the road would be obstructed for a considerable length of time by the train thus accidentally brought to a stand.

The engines thus kept prepared for accidents are called *Reserve Engines*.

## THE LOCOMOTIVE.

31. Another cause which renders it necessary at certain points of the line to keep engines waiting with their steam up, is the existence of exceptional gradients.

Thus, if a railway be generally laid out with gradients of about 15 feet a mile, but at a particular point a natural elevation of the ground, or other cause, renders the construction of a gradient rising at the rate of 60 feet a mile necessary, then the engines which are adapted to the general character of the line become insufficient for such exceptional gradient; and, in such case, the expedient resorted to is to keep one or more powerful engines constantly waiting with their steam up at the foot of the incline, for the purpose of aiding in propelling the trains in their ascent.

These engines are denominated *Assistant Engines* or *Bank Engines*. Their mode of operation is as follows. They wait near the foot of the incline in a siding provided for the purpose; and when a train arrives and begins to ascend, the assistant engine follows it, and, pushing from behind, aids the regular engine in front in propelling it up the plane. When it arrives at the summit, the assistant engine drops off, and, descending the plane, returns to its station.

32. It appeared from calculations, based on the preceding principles, which I made some years since, that on the Belgian lines the average distance run by each engine lighted was 78 miles, and on some of the French lines 76 miles. It also appeared that each engine lighted was kept seven and a half hours standing with steam up, including, of course, the reserve engines. Thus, it follows, that for every ten miles over which an engine works, it is kept an hour standing.

33. The fuel consumed in working a railway may be classed under three heads:—

1st. That which is consumed in lighting the engines and raising their steam, to prepare them for work.

2nd. That which is consumed while the engines stand with their steam up, waiting for the trains they are intended to draw, or standing in reserve, prepared for the contingency of accidents on the line.

3rd. That which is consumed in drawing the trains.

When the engine has stopped work, its fire-box is cleared, preparatory to the engine being cleaned. A certain portion of coke, more or less, according to the state of the fire-box at the moment the engine is stopped, is collected in this way half consumed. This coke is to a certain extent available to aid in lighting the engine when next started. The small coke which has been rejected as unfit for the working engine is mixed, in a greater or less proportion, by the engineer with the large coke used for

## ECONOMY OF FUEL.

raising the steam, for in this process the draft is not so strong as to carry this small coke injuriously through the tubes. The small coke is also used, mixed in a certain proportion with the large coke, for keeping the steam up in the reserve engines.

The quantity of coke consumed in drawing a train will depend upon the magnitude and weight of the train, and the speed with which it is moved. The greater the resistance which it has to overcome, the greater will be the consumption of fuel in a given distance. The resistance increases in a high ratio with the speed. Now as the speed of passenger trains is usually greater than that of goods trains, the consumption of fuel, so far as it is affected by the speed, will be greater in the former than in the latter; but, on the other hand, goods trains consisting of a much greater number of vehicles and of a greater gross weight than passenger trains, the resistance due to the load is greater in the latter case than in the former.

On the Belgian railways the economy of fuel is very strictly attended to. Rules are established by which a certain weight of coke is allowed to the engineer for the different purposes.

For lighting and raising the steam, 280 kilogrammes, equal to 618 lbs., of coke are allowed.

For each passenger coach drawn,  $\frac{3}{4}$  of a kilogramme per kilometre, equal to 2.64 lbs. per mile, are allowed.

For each loaded goods waggon,  $\frac{2}{3}$  of a kilogramme per kilometre, equal to 2.35 lbs. per mile, are allowed.

Two empty waggons are accounted as equal to a loaded one, and  $2\frac{1}{2}$  kilogrammes per kilometre, equal to 8.82 lbs. per mile, are allowed for an engine without a load.

Ten kilogrammes, equal to 22 lbs., per hour are allowed for keeping up the steam while an engine is standing.

These quantities are, however, understood to be average major limits which ought not to be exceeded. To stimulate the engineers and their superintendents to the observance of a due economy of fuel, premiums are awarded, in proportion to the extent of the saving effected upon these allowances; 5s. 6d. a ton is allowed to the engineer for every ton of coke by which his actual consumption falls short of these limits, and a further premium of one-fourth of this amount is allowed to the superintendents of the locomotive department.

34. In the locomotive department, a register should be kept of the fuel consumed, distinguishing such consumption under the three heads of standing, lighting, and working, together with which should be noted the hours standing, the engines lighted, and the mileage worked. There is nothing impracticable or difficult in the maintenance of such a register in every well-organised establishment, and such a one is regularly kept in the

## THE LOCOMOTIVE.

administration of the Belgian railways. It appears from these records, that the following was the fuel consumed for these purposes respectively on the Belgian railways during the years 1846 and 1847:—

	1846.	1847.
Number of hours standing . . . . .	204124	214610
Number of lbs. of coke consumed in standing	4,503077	5,306573
Average number of lbs. consumed per hour .	22·0	24·7
Number of engines lighted . . . . .	27452	30676
Total number of lbs. consumed in lighting .	16,828505	18,605263
Average number of lbs. consumed per engine lighted . . . . .	613·0	606·5
Total mileage worked . . . . .	2,027014	2,366885
Total number of lbs. of coke consumed in working . . . . .	60,698538	71,500965
Average number of lbs. consumed per mile worked . . . . .	30·0	30·0
Average consumption per mile, including coke consumed in lighting and standing . . . . .	40·5	40·3

It may then be stated in round numbers, that 600 lbs. of fuel are consumed in lighting an engine, and raising the steam, and that every engine lighted travels, on an average, as worked upon the Belgian lines, 70 miles.

The fuel consumed in lighting adds, therefore,  $8\frac{1}{2}$  lbs. per mile to the working consumption, which latter being 30 lbs., the proportion consumed in lighting is 28 per cent. The fuel consumed in standing with steam up, either as an engine of reserve or otherwise, adds  $1\frac{1}{2}$  per cent. more to the working consumption per mile, the total amount of which may be taken in round numbers at 40 lbs., as these railways are worked.

35. One of the most striking results of the calculations which I have made of the performance of locomotive engines as well in England as on the continent, is the small amount of useful service obtained from them.

36. It appears that in each run an engine, on the Belgian lines, at the most improved epoch of the service yet reported, did not quite average 78 miles, and that even this was performed only four days in seven. Thus the average daily work of an engine would appear to be only 44 miles.

But it also appears, that for 74 miles run the engine is kept, on an average,  $7\frac{1}{2}$  hours standing. This being reduced to a daily average, leads to the conclusion, that the daily service of the engines consisted in 44 miles run and 4 hours standing with the steam up.

But as the average speed on the Belgian railway is about 20

## MILEAGE OF ENGINES.

miles an hour, the run of 44 miles would occupy more than two hours.

The daily service of an engine, therefore, expressed in time, would be about 2 hours working and 4 waiting with steam up.

37. These inferences are so striking, that we naturally turn elsewhere to inquire how far the results of other railways vary from or corroborate them.

I accordingly made like calculations upon the statistical reports of most of the continental railways, and found that the average daily mileage of the engines is under 33 miles, being therefore inferior to the useful service of the Belgian engines.

38. The data supplied by the English railways are so scanty, and in general so vague, as to afford no adequate means of general comparison with the results above given. In the case of the London and North-Western lines however, a more detailed account was published, which, considering the great extent and traffic of that system of railways, is entitled to much attention.

The traffic of these lines was worked, during the twelve months ending June 30, 1849, by 457 locomotive engines, the total mileage of which was as follows:—

	Mileage.
Passenger engines . . . . .	4,649,556
Goods engines . . . . .	2,882,674
	<hr/>
Total .	7,532,230

Hence the average daily run of each engine was 45 miles.

These results, obtained from services so various and numerous, leave no doubt that the average daily service of each locomotive engine is much less than would have been expected. If the average speed on the North-Western lines be taken at 28 miles an hour, we shall obtain the singular and somewhat unexpected conclusion, that the engines, taken one with another, are each worked with traffic little more than one hour and a half a day.

By a return which I obtained from the North-Western Company, I found that, in the twelve months ending June 30, 1849, they had in active employment an average number of 275 engine-drivers, and an equal number of firemen. Now it has already been stated, that during the same period the number of engines employed was 457; there were thus 10 engine drivers and firemen for every 16 engines.

By dividing the total annual mileage of the engines by the total number of engine-drivers and firemen employed, we shall find the total annual distance driven by each; and dividing this by 365, we shall obtain the average daily work of each engine-driver and fireman, expressed in *distance*. This distance, divided by the



## THE LOCOMOTIVE.

average speed in miles per hour, will give the daily work on the road in time. The following are the details of this for the lines worked by the North-Western Company:—

Total mileage of engines . . . . .	7,532,230
Number of engine drivers and firemen . . . . .	275
Annual distance worked per head . . . . .	27,380 miles
Daily distance worked per head . . . . .	75 ,,
Time daily on the road (at the average speed of 28 miles per hour) . . . . .	2 $\frac{3}{4}$ hours

If it be assumed that the engines, one with another, work on alternate days, the actual distance run in each trip by each engine on the system of lines worked by the North-Western Company will be 90 miles; which in time, at 28 miles an hour, would be  $3\frac{3}{4}$  hours.

It appears, therefore, that the locomotive power is worked to greater advantage on these than on the continental lines generally. We have seen that the average distance run by each engine lighted on the Belgian lines was about 78 miles.

39. It has been customary, in some of the reports presented to the railway companies, to institute comparisons between one line of railway and another, founded upon the relation between the locomotive stock and the length of the line.

Now such a mode of comparison can afford no legitimate consequence of the least importance, either in a financial or mechanical point of view. The quantity of locomotive power does not in any manner depend on the length of the railway. The locomotive power is used to draw the traffic, and for no other purpose. Its quantity, therefore, will depend on the quantity of the traffic, and the average distance to which it is carried, or, in other words, on the mileage of the goods and passengers.

Two railways having the same traffic mileage will require the same locomotive stock, be their length equal or unequal. If a million of tons of goods require to be annually transported an average distance of 500 miles, and ten millions of passengers also require to be annually transported 300 miles, it is manifest, that the same locomotive power will be requisite to execute the traffic, whether the railway on which it is carried be 400 miles or 800 miles in length.

If the object be to compare the merits of the management of the locomotive power, then the test of comparison should be the quantity of work executed by a given quantity of this power; and the quantity of work must be decided by the useful mileage of the engines, and not by the length of the line.

Nevertheless, we find railway authorities in high repute announcing, that to stock a line requires so many engines per

## LOCOMOTIVE STOCK.

mile. To such a statement there can be no objection, provided it be made with the understanding that it applies to railways only which have a certain understood amount of average traffic.

But it is clear that, with every variation of the traffic upon the proposed railway, there must be a corresponding and proportional variation in the necessary amount of locomotive stock.

40. A legitimate mode of comparing the merits of the management of the locomotive department will be found in the estimate of the average daily mileage of the engines.

It is evident, that if we find on one railway—for example, the North-Western,—the engines performing a daily mileage of 45 miles, while on another—the North of France, we find them performing a daily service under 30 miles, that the locomotive stock in the one case was more profitably managed than the other in the ratio of 2 to 3, it being understood that other things are similar. But even in this comparison it would be necessary that the length and weight of the trains should be taken into account; for if it prove that the weight of the train drawn 30 miles is greater than the weight of the train drawn 45 miles in the proportion of 3 to 2, then the useful labour of the engines will, after all, be the same. In short, the test, and the only test, of the useful effect of the locomotive power is the actual mileage (including in that term the quantity) of the traffic which it executes in a given time.

41. The conditions which determine the amount of the locomotive stock necessary to work any given railway form a very important subject of inquiry in railway economy; but it is a subject upon which we as yet possess but scanty and unsatisfactory data. As has been already stated, railway authorities have, with more rashness than skill, given a sort of rough estimate of it at so much per mile. This must, however, be regarded as utterly unworthy of attention, for the very intelligible reasons already explained.

The amount of locomotive stock depends exclusively on the mileage of the traffic. The question is thus reduced to the determination of the number of engines necessary to work a given mileage.

If we assume the results of the working of the North-Western lines as a general modulus, it would follow, that to find the quantity of stock necessary for working a given daily mileage, it will be sufficient to divide this mileage by 45; the quotient will express the requisite number of locomotive engines.

42. From calculations based upon authentic statistical returns which were published in a series of articles, written by me for the "Times," in 1851, it appeared, that in the year 1850, the gross receipts of all the European railways then in operation, amounted to 23,309,000*l.*, of which 12,755,000*l.*, or about the half, was collected on the railways of the United Kingdom.

## THE LOCOMOTIVE.

Of this amount about 60 per cent has been expended on personal locomotion, and 40 per cent on the transport of goods of every denomination.

43. The movement of the locomotive engines in executing this traffic has been as follows :—

	Miles run by engines.
United Kingdom . . . . .	40,162000
Germanic States . . . . .	23,572000
France . . . . .	10,041000
Belgium . . . . .	4,540000
Total distance travelled by locomotive engines in 1850 . . . . .	78,315000

44. Since the date of these calculations, the amount of railway locomotion, as well in the United Kingdom as throughout Europe generally, has undergone a great increase. Thus, in the half year ending 30th June, 1852, the gross receipts of the railways in the United Kingdom amounted to 7,195551*l*.

The mileage, or aggregate distance travelled by the locomotive engine, has increased in a proportion still greater than the increase of the gross receipts. Thus, while in 1850, the total annual mileage of the engines on the railways of the United Kingdom was about forty millions, in the first six months of 1852 it was twenty-eight and a half millions, being at the rate of fifty-seven millions in the year.

It may now (1854) be assumed that the aggregate annual mileage of the locomotive engines on all the European railways is not less than *an hundred and twenty millions of miles!*

45. In the performance of this work, the total quantity of coal consumed is two millions and three quarters of tons.

46. This movement is shared between passengers and goods as follows :—

Distance travelled by passenger trains . . . . .	72,000000
,, ,, goods ,, . . . . .	48,000000

Since each passenger train transported on an average 70 passengers, and each goods train 60 tons, it follows that the total locomotion of persons within the year was equivalent to 5040,000000 persons carried one mile, and the transport of goods to 2880,000000 tons transported one mile.

The number of locomotive engines employed in executing this movement was about 7500, of which 3700 were employed on the British railways, and about 5000 were constructed in England.

Fig 5.

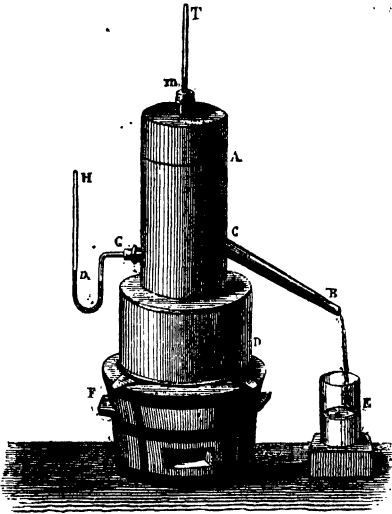
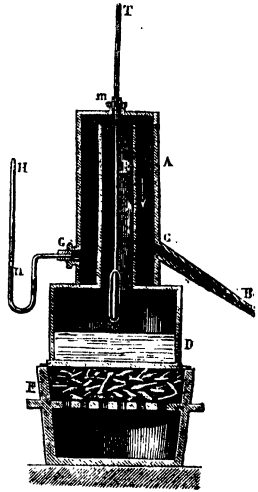

Fig. 6.



METHOD OF DETERMINING THE BOILING POINT.

## THE THERMOMETER.

1. Heat.—2. Sensible heat.—3. Latent heat.—4. Contraction and dilatation.—5. Liquefaction and solidification.—6. Vaporisation and Condensation.—7. Incandescence.—8. Combustion.—9. Temperature.—10. Conduction.—11. Radiation.—12. Some bodies are pervious to heat.—13. Some reflect heat.—14. Means of measuring the degrees of heat.—15. Mercurial thermometer.—16. Preparation of mercury.—17. Selection of tube.—18. Formation of bulb.—19. How the tube is filled.—20. Scale applied.—21. Graduation of scale.—22. Zero point.—23. Standard points.—24. Freezing and boiling temperatures universally adopted.—25. Fahrenheit's scale.—26. Centigrade.—27. Reaumur's.—28. Increase of volume of mercury.—29. Uniformity of its dilatation.—30. Standard thermometer.—31. Range of scale.—32. Why mercury is employed in thermometers.—33. Self-registering thermometers.—34. Alcohol thermometers.—35. Air thermometer.—36. Differential thermometer.

1. HEAT is one of the physical agencies upon which the well-being of organised nature in general, and of the human race in particular, is most essentially dependent. The instruments, therefore, which have been contrived for indicating and measuring its quantity and degrees have great interest and importance,

## THE THERMOMETER.

not only in physical science, but in the arts and in domestic economy.

2. But to comprehend clearly the principle and application of these instruments, it is first necessary to obtain some acquaintance with the principal effects of heat, upon which their indications depend, and the degrees of which they are applied to measure.

One of the most familiar of these effects is the sense of more or less warmth which a body, when it receives or loses heat, produces upon our organs.

When the heat received or lost by a body is attended with this sense of increased or diminished warmth, it is called *sensible heat*.

3. But it will occur in certain cases that a body may receive a very large accession of heat without any increased sense of warmth being produced by it, and may, on the other hand, lose a considerable quantity of heat without exciting any diminished sense of warmth. The heat which a body would thus receive or lose without affecting the senses, is called *latent heat*.

4. When a body receives or loses heat, it generally suffers a change in its dimensions, the increase of heat being usually attended with an increase, and the diminution of heat with a diminution of volume.

This enlargement of volume due to the accession of heat is called *dilatation*, and the diminution of volume attending the loss of heat is called *contraction*.

There are, however, certain exceptional cases in which heat, whether received or lost, is attended by no change of volume, and others in which changes take place the reverse of those just mentioned; that is to say, where an accession of heat is accompanied by a diminution, and a loss of heat by an increase of volume.

5. If heat be imparted in sufficient quantity to a solid body, it will pass into the liquid state. Thus, ice or lead, being solid, will become liquid by receiving a sufficient accession of heat. This change is called *fusion* or *liquefaction*.

If heat be abstracted in sufficient quantity from a body in the liquid state, it will pass into the solid state. Thus, water or molten lead losing heat in sufficient quantity will become solid. This change is called *congelation* or *solidification*; the former term being applied to substances which are usually liquid, and the latter to those which are usually solid.

6. If heat be imparted in sufficient quantity to a body in the liquid state, it will pass into the state of vapour. Thus, water being heated sufficiently, will pass into the form of steam. This change is called *vaporisation*.

## EFFECTS OF HEAT.

If a body in the state of vapour lose heat in sufficient quantity, it will pass into the liquid state. Thus, if a certain quantity of heat be abstracted from steam, it will become water.

This change is called *condensation*; because, in passing from the vaporous to the liquid state, the body always undergoes a very considerable diminution of volume, and therefore becomes condensed.

7. Heat, when imparted to bodies in a certain quantity, will in some cases render them luminous.

Thus, if metal be heated to a certain degree, it will become *red-hot*; a term signifying merely that it emits red light. This luminous state, which is consequent on the accession of heat, is called *incandescence*.

The more intense the heat is which is imparted to an incandescent body, the more *white* will be the light which it emits. When it first becomes luminous, it emits a dusky-red light. The redness becomes brighter as the heat is augmented, until at length, when the heat becomes extremely intense, it emits a white light resembling solar light.

A bar of iron submitted to the action of a furnace will exhibit a succession of phenomena illustrative of this.

8. Certain bodies, when surrounded by atmospheric air, being heated to a certain degree, will enter into chemical combination with the oxygen gas which forms one of the constituents of the atmosphere.

This combination will be attended with a large development of heat, which is accompanied usually by incandescence and flame.

This phenomenon is called *combustion*, and the bodies which are susceptible of this effect are called *combustibles*.

The flame, which is one of the effects of combustion, is gas rendered incandescent by heat.

The phenomena of combustion and properties of combustibles have been fully explained in our Tract on "Fire."

9. The degree of sensible heat by which a body is affected, is called its *temperature*, and the instruments by which the temperature of bodies is indicated and measured are called *thermometers* and *pyrometers*; the latter term being applied to those which are adapted to the measurement of the higher order of temperatures.

Changes of temperature are indicated and measured by the change of volume which they produce upon bodies very susceptible of dilatation. Such bodies are called *thermoscopic bodies*. The principal of these are, for thermometers, mercury, alcohol, and air; and, for pyrometers, the metals, and especially those which are most difficult of fusion.

## THE THERMOMETER.

10. When heat is communicated to any part of a body, the temperature of that part is momentarily raised above the general temperature of the body. This excessive heat, however, is gradually transmitted from particle to particle throughout the entire volume, until it becomes uniformly diffused, and the temperature of the body becomes equalised.

This quality, in virtue of which heat is transmitted from particle to particle throughout the volume of a body, is called *conductibility*.

Bodies have the quality of conductibility in different degrees; those being called good conductors in which any inequality of temperature is quickly equalised, the excess of heat being transmitted with great promptitude and facility from particle to particle. Those in which it passes more slowly and imperfectly through the dimensions of a body, and in which, therefore, the equilibrium of temperature is more slowly established, are called imperfect conductors. Bodies, in which the excess of heat fails to be transmitted from particle to particle before it has been dissipated in other ways, are called non-conductors.

The metals in general are good conductors, but different metals have different degrees of conductibility. The earths and woods are bad conductors, and soft, porous, and spongy substances still worse.

11. Heat is propagated from bodies which contain it by radiation in the same manner, and according to nearly the same rules, as those which govern the radiation of light. Thus, it proceeds in straight lines from the points whence it emanates, diverging in every direction, these lines being called thermal rays.

12. Certain bodies are pervious to the rays of heat, just as glass and other transparent media are pervious to the rays of light. They are called diathermanous bodies. Thus, atmospheric air and gaseous bodies in general are diathermanous.

The rays of heat are reflected and refracted according to the same laws as those of light. They are collected into foci by spherical mirrors and lenses, they are polarised both by reflection and refraction, and are subject to all the phenomena of double refraction by certain crystals in a manner analogous to that which takes place in relation to the rays of light.

Bodies are diathermanous in different degrees.

Imperfectly diathermanous bodies transmit some of the rays of heat which impinge on them, and absorb others; the portions which they absorb raising their temperature, but those which they transmit not affecting their temperature.

13. The surfaces of bodies also reflect heat in different

## EFFECTS OF HEAT.

degrees; those rays which they do not reflect they absorb. The processes of transmission, absorption, and reflection vary with the nature of the body and the state of its surface with respect to smoothness, roughness, or colour.

14. Of all the various effects of heat, that which is best adapted to indicate and measure temperature is dilatation and contraction. The same body always has the same volume at the same temperature, and always suffers the same change of volume with the same change of temperature.

Since the volume and change of volume admit of the most exact measurement and of the most precise numerical expression, they become the means of submitting the degrees of warmth and cold, or, which is the same, the degrees of temperature, to arithmetical measure and expression.

Although all bodies whatever are susceptible of dilatation and contraction by change of temperature, they are not equally convenient for thermoscopic agents.

For reasons which will become apparent hereafter, the most available thermoscopic substance for general purposes is mercury.

15. The mercurial thermometer consists of a capillary \* tube of glass, (fig. 1), at one end of which a thin spherical or cylindrical bulb is blown, the bulb and a part of the tube being filled with mercury.

When such an instrument is exposed to an increase of temperature, the glass and mercury will both expand. If they expanded in the same proportion, the capacity of the bulb and tube would be enlarged in the same proportion as the mercury contained in them, and, consequently, the column of mercury in the tube would neither rise nor fall, since the enlargement of its volume would be exactly equal to the enlargement of the capacity of the bulb and tube. If, however, the expansion of the bulb and tube be different from that of the mercury, the column in the tube will, after expansion, stand higher or lower than before, according as the expansion of the mercury is greater or less than the expansion of the bulb and tube.

It is found that the dilatability of mercury is greater than the

Fig. 1.



\* So called from its bore being so small as not to exceed the diameter of a hair, the Latin word *CAPILLA* signifying a hair.



## THE THERMOMETER.

dilatibility of glass in the proportion of nearly 20 to 1, and, consequently, the capacity of the bulb and tube will be less enlarged than the volume of the mercury contained in them in the proportion of nearly 1 to 20; consequently, for the reason above stated, every elevation of temperature by which the mercury and tube would be affected will cause the column of mercury to rise in the tube, and every diminution of temperature will cause it to fall.

The space through which the mercury will rise in the tube by a given increase of temperature will be greater or less according to the proportion which the tube bears to the capacity of the bulb. The smaller that proportion, the greater will be the elevation of the column produced by a given increase of temperature; for a given increase of temperature will produce a definite increase of volume in the mercury, and this increase of volume will fill a greater space in the tube in proportion to the smallness of the bore compared with the capacity of the bulb.

16. Such an instrument, without other appendages or preparation, would merely indicate such changes of temperature in a given place as would be sufficient to produce visible changes in the elevation of the column of mercury sustained in the tube. To render it useful for the purposes of science and art, and in domestic economy, various precautions are necessary, which have for their object to render the indications of different thermometers comparable with each other, and to supply exact numerical indications of measurement of the changes of temperature.

For this purpose it is necessary, in the first instance, that the mercury with which the tube is filled shall be perfectly pure and homogeneous. This object is attained by the same means as have been already explained in the case of the barometer.\*

17. In the selection of the tube it is necessary that it be capillary, that is to say, a tube having an extremely small bore, and that the bore should be of uniform magnitude throughout its entire length.

The smallness of the bore is essential to the sensibility of the instrument, as already explained; and its uniformity is necessary in order that the same change of volume of the mercury should correspond to the same length of the column in every part of the tube.

The uniformity of the bore of the tube may be tested by letting into it a small drop of mercury, sufficient to fill about a third of an inch of the tube. Let this be made to fall gradually through the entire length of the tube, stopping its motion at intervals, and

\* See our Tract on "The Barometer."

## FILLING THE TUBE.

let the space it occupies at different parts of the tube be measured. If this space be everywhere the same, the bore is uniform; if not, the tube must be rejected.

18. The bulb, whether spherical or cylindrical, can be formed upon the end of the tube by the ordinary process of glassblowing. The sensibility of the thermometer requires that the capacity of the bulb should bear a large proportion to the calibre of the tube. If, however, the capacity of the bulb be considerable, the quantity of mercury it contains may be so great that it will not be affected by the temperature of the surrounding medium with sufficient promptitude.

A cylindrical bulb of the same capacity will be more readily affected by the temperature of the surrounding medium than a spherical bulb, since it will expose a greater surface.

The glass of which the bulb is formed should be as thin as is compatible with the necessary strength, in order that the heat may pass more freely from the external medium to the mercury.

19. The tube to be filled is represented in fig. 2, where B A C is a tube, and c D a reservoir formed at the top for the purpose of filling it, which is to be afterwards detached. Let the tube be first dried by holding it over the flame of a spirit-lamp, so as to evaporate and expel all moisture which may be attached to the inner surface of the glass. To fill it, let a quantity of purified mercury be poured into the reservoir c D. This will not fall through the bore, being prevented by the air included in the reservoir A B and in the tube. To expel this, and cause the mercury to take its place, let the tube be placed in an inclined position over a charcoal fire or the flame of a spirit-lamp, so that the air shall be heated. When heated it will expand, force itself in bubbles through the mercury in c D, and escape into the atmosphere. This will continue until all the air in the bulb A B and in the tube A C has been expelled. The pressure of the atmosphere acting on the mercury in c D will then force it through the tube into the bulb A B, which, as well as the entire length of the tube, it will ultimately fill. If a sufficient quantity of mercury be supplied to the reservoir c D, the bulb A B, the tube A C, and a

Fig. 2.

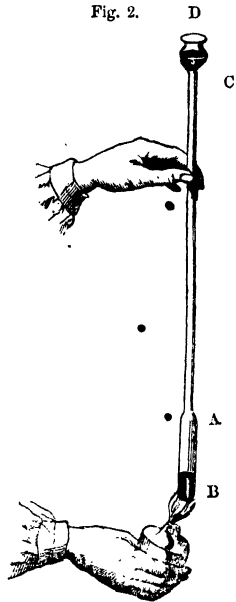

## THE THERMOMETER.

part of the reservoir *c d*, will be filled with mercury after all the air has been expelled.

When this has been accomplished, let the tube be removed from the source of heat, and allowed gradually to cool. A file applied at *c*, where the top of the tube is joined to the superior reservoir, detaches that reservoir from the tube, which remains with the bulb *A B* completely filled with mercury.

In this state the instrument would give no indication of change of temperature, no space being left for exhibiting the play of the mercury by dilatation and contraction.

To obtain space for this, let the bulb *A B* be exposed to a temperature higher than any which the instrument is intended to indicate. The mercury dilating will then overflow, and will continue to overflow until the mercury acquires the extreme temperature to which it is exposed.

A jet of flame being now directed by a blow-pipe (fig. 3), on

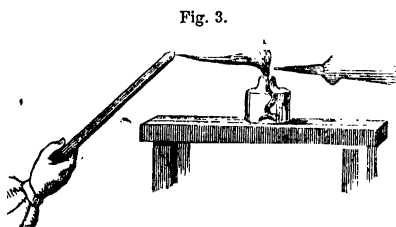

the end *c*, it will be hermetically\* sealed; after which, being allowed to cool, the mercurial column will subside, the space in the tube above it being a vacuum, since the air is expelled. The

column will continue to subside until the mercury assumes that state which corresponds to the temperature of the air surrounding the instrument.

20. The variation of the height of the mercurial column in such a tube will in all cases correspond with the changes of temperature incidental to the surrounding medium; but, in order that it may supply a numerical expression and measure of such changes, a scale must be attached to the tube, by which the variations of the column may be indicated, and the divisions or units of such scale must correspond to some known change of temperature. It is evident that such a scale, like all other standards for the

\* An opening of a tube or vessel is said to be hermetically closed or sealed when the material of the tube or vessel itself is fused around it, and the edges when thus soft brought together so as to close the opening, being then allowed to harden by cold as sealing-wax does. The term "hermetically" means chemically, the science of alchemy which preceded chemistry being supposed to have been invented by Hermes Trismegistus. So that "hermetically sealed or closed" means to be sealed or closed in the manner adopted in chemical vessels.

## STANDARD POINTS.

arithmetical measure of physical effects, must be to some extent arbitrary. We accordingly find different scales and different thermometric units prevailing in different countries, and even in the same country at different times.

21. Whatever thermometric unit be adopted, it is necessary that two standard temperatures be selected, to which the mercury can be reduced at the times and places where thermometers may be required to be constructed or verified. The instrument being exposed to these two temperatures, the points at which the mercurial column stands are marked upon the scale. The space upon the scale between these points is then divided into a certain number of equal parts, which are called degrees, the degree being the thermometric unit. The same divisions are then continued upon the scale above the higher and below the lower standard point, and such divisions may be continued indefinitely. The scale is then complete.

In this process, the number of equal parts into which the space between the standard points is divided, is altogether arbitrary.

22. It now remains to number the scale; and, for this purpose, a zero point must be selected. If there existed a minor limit to temperature, a temperature below which no body could possibly fall, then such a temperature would supply a natural thermometric zero, and the scale might be numbered upwards from it.

In that case, although the thermometric unit would still remain arbitrary, the zero of the scale would not be so. But no such natural thermometric zero exists.

There is no natural limit either to the increase or diminution of temperature. The zero, therefore, of the thermometric scale, like the thermometric scale itself, must be arbitrary.

23. Thermal phenomena present great varieties of standard temperatures, by which thermometric scales may be established, and which may serve equally as terms of temperature for the purpose of distinguishing the indications of different thermometers constructed at different times and places. Thus, the temperatures at which all solid bodies fuse, and those at which all liquids congeal, are fixed. For different bodies these are different, but always the same for the same body. In like manner, the temperatures at which all liquids boil under a given pressure are invariable for the same liquids, though different for different liquids. The temperature of the blood in the human species presents another example of a fixed temperature.

24. Now, any two of these various temperatures naturally fixed might be taken as the thermometric standards, the choice being altogether arbitrary. Thus, it appears that the arithmetical division of the scale, and consequently the thermometric unit, the

## THE THERMOMETER.

position of its zero, and, in fine, the standard temperatures by which alone the indication of different thermometers can be rendered comparable, are severally arbitrary. Unanimity, nevertheless, has prevailed in the selection of standard temperatures. The temperature at which ice melts, and that at which distilled water boils, when the barometer stands at 29·8 inches, have been adopted in all countries as the two temperatures with reference to which thermometric scales are constructed.

The bulb and tube, as already described, being filled with pure mercury, and a blank scale being attached to the tube, the instrument is immersed successively in melting ice and boiling water, and the points at which the mercurial column stands in each case are marked upon the scale. The former is called the FREEZING-POINT, and the latter the BOILING-POINT.

The apparatus by which the freezing point is determined is shown in fig. 4. The thermometer is immersed nearly to the level of the mercury in a vessel of pounded ice, which being in a state of fusion, the water proceeding from it discharged through a funnel in the bottom is received in a vessel placed under it.

Fig. 4.

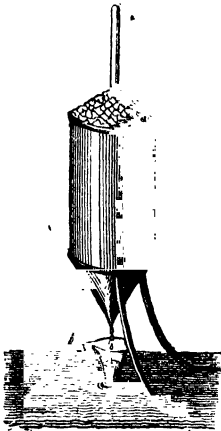

The apparatus for determining the boiling point is shown in fig. 5, where  $\Pi$  is the boiler, placed over a charcoal furnace, the whole being shown in section in fig. 6, p. 145. From the top of the boiler a tube proceeds, open at the top, which is enveloped in another larger one,  $A$ , closed at the top, and soldered at the bottom to the top of the boiler. In the external tube  $A$ , there are three openings, in one of which,  $m$ , the tube of the thermometer  $T$  is inserted. In another, a siphon mercurial gauge  $G \Pi$ , and in the third a discharge pipe  $C B$ , is inserted. When the water

boils the steam rises, surrounding the bulb and tube, and descending between the two tubes, issues from the discharge pipe  $B$ . If the steam be generated too rapidly in the boiler, it will press on the mercury in the gauge, which will then stand at a higher level,  $n$ , in the ascending than in the descending leg. The pressure of the steam will be in that case greater than that of the atmosphere, and the force of the furnace must be moderated until the levels of the mercury in the two legs of the siphon

## DIFFERENT SCALES.

coincide. In that case the pressure of the steam will be exactly equal to that of the atmosphere.

25. The same unanimity has not prevailed either as respects the unit or the thermometric zero. In England, Holland, some of the German States, and in North America, the interval between the freezing and boiling points is divided into 180 equal parts, each part representing the thermometric unit. The scale is continued by equal divisions above the boiling and below the freezing points.

The zero is placed at the thirty-second division below the freezing point; so that, on this scale, the freezing point is  $32^\circ$ , and the boiling point  $32^\circ + 180^\circ = 212^\circ$ .

This scale is known as Fahrenheit's, and was adopted about 1724.

The reason for fixing the zero of the scale at  $32^\circ$  below the freezing point is, that that point indicated a temperature which was at that time believed to be the natural zero of temperature, or the greatest degree of cold that could exist, being the most intense cold which had been observed in Iceland.

We shall see hereafter that much lower temperatures, natural and artificial, have been since observed.

The division of the interval between the freezing and boiling points into 180 equal parts was founded upon some inexact supposition connected with the dilatation of mercury.

The divisions of this scale are continued in the same manner below zero, such divisions being considered negative, and expressed by the negative sign prefixed to them. Thus,  $+ 32^\circ$  signifies  $32^\circ$  above zero, but  $- 32^\circ$  signifies  $32^\circ$  below zero.

26. In France, Sweden, and some other parts of Europe, the Centigrade scale prevails.

In this scale the interval between the freezing and boiling points is divided into 100 equal parts, and the zero is placed at the freezing point.

27. In some countries the scale of Reaumur is used, in which the interval between the freezing and boiling points is divided into eighty equal parts, the zero being placed at the freezing point.

28. It has been ascertained by experiment, that mercury, when raised from  $32^\circ$  to  $212^\circ$ , suffers an increment of volume amounting to  $\frac{1}{111}$ ths of its volume at  $32^\circ$ . Thus, 111 cubic inches of mercury at  $32^\circ$  will, if raised to  $212^\circ$ , become 113 cubic inches. From this may be deduced the increment of volume which mercury receives for each degree of temperature. For, since the increase of volume corresponding to an elevation of  $180^\circ$  is  $\frac{2}{111}$  of its volume at  $32^\circ$ , we shall find the increment of volume corresponding to one degree by dividing  $\frac{2}{111}$  by 180, or, what is the

## THE THERMOMETER.

same, by dividing  $\frac{1}{111}$  by 90, which gives  $\frac{1}{9990}$ . For each degree of temperature by which the mercury is raised, it will therefore receive an increment of volume amounting to the 9990th part of its volume at  $32^{\circ}$ , and it follows, that the weight of mercury which fills the portion of a thermometric tube representing one degree of temperature, will be the 9990th part of the total weight contained in the bulb and tube.

29. In adopting the dilatation of mercury as a measure of temperature, it is assumed that equal dilatations of this fluid are produced by equal increments of heat. Now, although it is certain that to raise a given quantity of mercury from the freezing to the boiling point will always require the same quantity of heat, it does not follow that equal increments of volume will correspond to equal increments of heat throughout the whole extent of the thermometric scale. Thus, although the same quantity of heat must always be imparted to the mercury contained in the tube to raise it from  $32^{\circ}$  to  $212^{\circ}$ , it may happen that more or less heat may be required to raise it from  $32^{\circ}$  to  $42^{\circ}$ , than from  $202^{\circ}$  to  $212^{\circ}$ . In other words, the dilatation produced by equal increments of heat, in different parts of the scale, might be variable. Experiments conducted, however, under all the conditions necessary to ensure accurate results, have proved that mercury is uniformly dilated between the freezing and boiling points, or that equal increments of heat imparted to it produce equal increments of volume.

30. A thermometer having once been carefully graduated may be used as a standard instrument for graduating other thermometers, just as good chronometers once accurately set are used as regulators for other time-pieces. To graduate a thermometer by means of such a standard, it is only necessary to expose the two instruments to the same varying temperatures, and to mark upon the blank scale of that which is to be graduated two points corresponding to any two temperatures shown by the standard thermometer, and then to divide the scale accordingly.

Thus, for example, if the two instruments be immersed in warm water and the column of the standard thermometer be observed to indicate the temperature of  $150^{\circ}$ , let the point at which the mercury stands in the other thermometer be marked 150 upon its scale.

Let the two instruments be then immersed in cold water and let us suppose that the standard thermometer indicates  $50^{\circ}$ . Let the point at which the instrument to be graduated stands be then marked. Let the intervals of the scale between these two points, thus corresponding to the temperatures of  $50^{\circ}$  and  $150^{\circ}$ , be divided into one hundred equal parts; each part will be a degree

## STANDARD THERMOMETER.

in the scale, which may be continued by like divisions above  $150^{\circ}$  and below  $50^{\circ}$ .

31. The range of the scale of thermometers is determined by the purpose to which they are to be applied. Thus, thermometers intended to indicate the temperature of dwelling-houses need not range above or below the extreme temperatures of the air, and the scale does not usually extend much below the freezing point nor above  $100^{\circ}$ ; and thus the sensitiveness of the instrument may be increased, since a considerable length of the tube may represent a limited range of the scale.

32. Mercury possesses several thermal qualities which render it a convenient fluid for common thermometers. It is highly sensitive to change of temperature, dilating with promptitude by the same increments of heat with great regularity and through a considerable range of temperature. It will be shown hereafter that a smaller quantity of heat produces in it a greater dilatation than in most other liquids. It freezes at a very low and boils at a very high temperature. At the temperatures which are not near these extreme limits, it expands and contracts with considerable uniformity.

The freezing point of mercury being  $-40^{\circ}$ , or  $40^{\circ}$  below zero, and its boiling point  $+600^{\circ}$ , such a thermometer will have correct indications through a very large range of temperature.

33. It is sometimes needed, in the absence of an observer, to ascertain the variations which may have taken place in a thermometer. Instruments called self-registering thermometers have been contrived, which partially serve this purpose by indicating, not the variations of the mercurial column, but the limits of its play within a given time. This is accomplished by floating indices placed on the mercury within the tube, which are so adapted that one is capable of being raised with the column, but not depressed, and the other of being depressed, but not raised. The consequence is, that one of these indices will remain at the highest, and the other at the lowest point which the mercurial column may have attained in the interval, and thus register the highest point and lowest point of its range.

One of the most common and useful forms of self-registering thermometer is that of Rutherford, shown in fig. 7, which consists of two tubes, attached in a horizontal position to a plate of glass, being bent at right angles near the bulbs; one, A, containing mercury and the other, B, alcohol. In the tube of the former there is a small piece of iron wire, which moves in it freely, being pushed along by the mercury as it expands. When the tube is placed in the vertical position the wire falls back upon the mercury.

The other tube contains a small piece of coloured glass, having



## THE THERMOMETER.

a knob at each end, which allows the alcohol to pass it freely from right to left. But when the alcohol contracts and moves

Fig. 7.

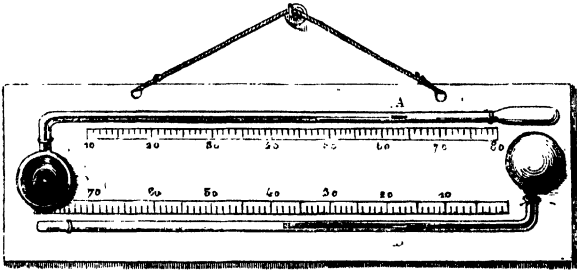

towards the bulb, it carries with it the glass index, which consequently remains in the position given to it when exposed to the lowest temperature.

The instrument, therefore, after the lapse of any time, indicates the highest and lowest temperatures to which it has been exposed. A small magnet is sometimes attached, to aid in bringing the wire gently into contact again with the mercury, and in cheap instruments, especially in England, the scale is engraved on a slab of wood instead of a plate of glass.

A maximum and minimum thermometer has lately been introduced by Messrs. Negretti and Zambra, which is a modification of the above. Having introduced into the tube a little rod of glass, the tube is softened with the blow-pipe, and slightly bent where the glass rod stands, so that it becomes fixed in the tube, leaving nevertheless sufficient space around it for the mercury to pass. Supposing, then, the instrument to be suspended with the tube horizontal, and exposed to an increasing temperature, the mercury passes the bend; but when the temperature falls, the mercury which has just passed will not return. The extremity of the column will therefore indicate the highest temperature to which the instrument has been exposed. This instrument is represented in fig. 8.

34. Alcohol is frequently used as a thermoscopic liquid. It has the advantage of being applicable to a range of temperature below the freezing point of mercury; no degree of cold yet observed in nature or attained by artificial processes having frozen it. It is usually coloured so as to render the column easily observable in the tube.

35. Atmospheric air is a good thermoscopic fluid. It has the

## DIFFERENTIAL THERMOMETERS.

advantage over liquids in retaining its gaseous state at all temperatures, and in the perfect uniformity of its dilatation and

Fig. 8.

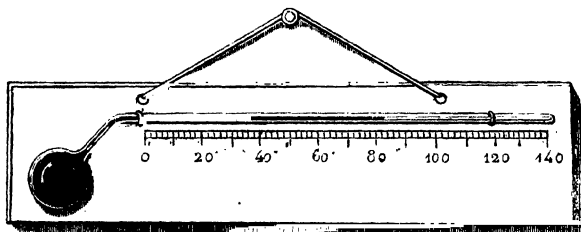

contraction. It is also highly sensitive, indicating changes of temperature with great promptitude. Since, however, it is not visible, its expansion and contraction must be rendered observable by expedients which interfere with and render complicated its indications.

The air thermometer of Drebbel, or according to some of Sanctorius, is represented in fig. 9. A glass tube, A B, open at one end, and having a large thin bulb c at the other, is placed with its open end in a coloured liquid, so that the air contained in the tube shall have a less pressure than the atmosphere. A column of the liquid will therefore be sustained in the tube A B, the weight of which will represent the difference between the pressure of the external air and the air inclosed in the tube.

Fig. 9.

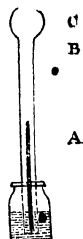

If the bulb c be exposed to a varying temperature, the air included in it will expand and contract, and will cause the column of coloured liquid in the tube A B to rise and fall, thereby indicating the changes of temperature.

Fig. 10.

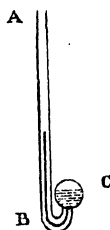

Another form of air thermometer is represented in fig. 10. The air included fills half the capacity of the bulb c, and its expansion and contraction cause the coloured liquid to rise or fall in the tube A B.

36. Of all forms of air thermometer, that which has proved of greatest use in physical enquiries is the differential thermometer represented in figs. 11, 12. This consists of two glass bulbs, A and B, connected by a rectangular glass tube. In the horizontal part of the tube a small quantity of coloured liquid (sulphuric acid, for example) is placed. Atmospheric air is contained in the bulbs and tube, separated into two parts by the

## THE THERMOMETER.

liquid. The instrument is so adjusted that, when the drop of liquid is at the middle of the horizontal tube, the air in the bulbs

Fig. 11.

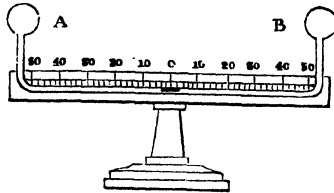

has the same pressure; and having equal volumes, the quantities at each side of the liquid are necessarily equal. If the bulbs be affected by different temperatures, the liquid will be driven from

Fig. 12.

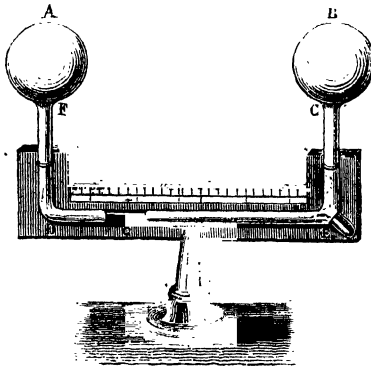

that side at which the temperature is greatest, and the extent of its departure from the zero or middle is indicated by the scale.

By these instruments changes of temperature, not exceeding the 6000th part of a degree, are rendered sensible.

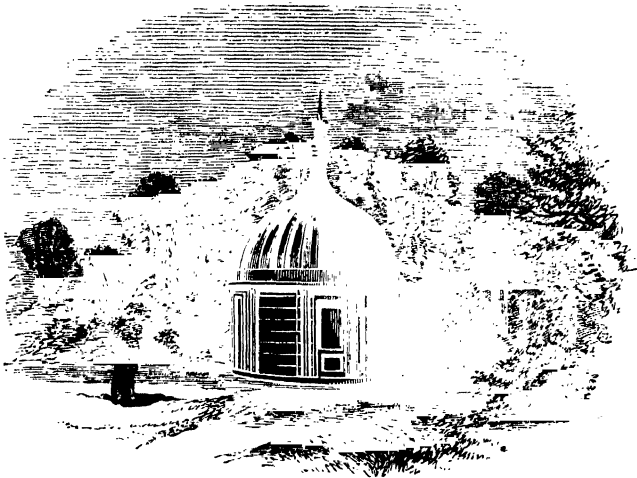

MR. BISHOP'S OBSERVATORY, REGENT'S PARK, MEMORABLE BY THE DISCOVERY  
THERE OF ELEVEN PLANETS.

## THE NEW PLANETS.

- 1.—Discovery of these planets.—2. The old planets.—3. Numerical law of their distances.—4. A missing planet.—5. Conjecture of Professor Bode.—6. Discovery of Ceres.—7. Of Pallas.—8. Theory of Dr. Olbers—a broken planet.—9. Discovery of Juno.—10. Of Vesta.—11. Rapid discovery of the others.—12. Table of the group.—13. Circumstances corroborating the theory of Dr. Olbers.—14. Amateur astronomers.—15. Minute bulk of these planets.—16. Corroboratory of Dr. Olbers' theory.—17. Force of gravity upon them.

1. WITHOUT being astronomers, every one who reads the newspapers must be familiar with the fact, that within the last few years a multitude of small planets has been discovered, which, notwithstanding the vigilance and sagacity of observers, in various parts of Europe, had hitherto escaped notice. As the circumstances attending and preceding this extraordinary mass of astronomical discovery are novel and interesting, we propose at present to bring them before our readers.

## THE NEW PLANETS.

2. Almost every one who knows anything beyond the limits of the most ordinary education, is aware that the solar system, as it was known until the last hundred years, consisted of six planets, which, proceeding outwards from the sun, received the mythological names of Mercury, Venus, the Earth or Tellus, Mars, Jupiter, and Saturn. It is now about three-quarters of a century since the late Sir William Herschel added one to this number, by the discovery of the planet since called Uranus, revolving outside the orbit of Saturn.

3. On comparing the successive distances of these several planets from the sun, it was observed by Kepler, that a remarkable numerical harmony prevailed among them. Thus, if we begin from the nearest planet to the sun, Mercury, and measure the intervals between planet and planet proceeding outwards, it will be found that each successive interval is almost exactly double the one before, subject, nevertheless, to a striking exception in the case of the interval between Mars and Jupiter.

4. Although this remarkable arithmetical harmony was not fulfilled with that numerical precision which characterises some other astronomical laws, there was, nevertheless, so striking an approximation to it as to produce a strong impression, that it must be founded upon some physical cause, and not merely accidental. The near approximation to its exact fulfilment, supplied grounds for a very reasonable conjecture, that a planet was wanting in the system, whose position between Mars and Jupiter would be such as to fill the vacant place in the progression of distances.

To show how strong the analogy was in favour of such a supposition, we have placed in the following table the succession of calculated distances from Mercury's orbit, which will exactly fulfil it, in juxtaposition with the actual distances of the planets, the earth's distance from the sun being the unit.

	Calculated distance from Mercury.	Actual distance from Mercury.
Venus . . . . .	0'3362	0'3362
Earth . . . . .	0'6724	0'6129
Mars . . . . .	1'3448	1'1366
Absent planet . . . . .	2'6896	
Jupiter . . . . .	5'3792	4'8157
Saturn . . . . .	10'7584	9'1517
Uranus . . . . .	21'5168	18'7953

By comparing these numbers, it will be apparent, that although the succession of distances does not correspond precisely with a

## DISCOVERY OF CERES AND PALLAS.

numerical series in duple progression, there is nevertheless a certain approach to such a series, and at all events a glaring breach of continuity between Mars and Jupiter.

5. Towards the close of the last century, Professor Bode, of Berlin, revived this question of a deficient planet, and gave the numerical progression which indicated its absence in the form in which it has just been stated; and an association of astronomers was formed under the auspices of the celebrated Baron de Zach, of Gotha, to organise and prosecute a course of observation, with the special purpose of searching for the supposed undiscovered member of the solar system. The very remarkable results which have followed this measure, the consequences of which have not even yet been fully developed, will presently be apparent.

6. On the first day of the present century, Professor Piazzi observing in the fine serene sky of Palermo, noticed a small star of about the 7th or 8th magnitude which was not registered in the catalogues. On the night of the 2nd Jan. again observing it, he found that its position relative to the surrounding stars was sensibly changed. The object appearing to be invested with a nebulous haze, he took it at first for a comet, and announced it as such to the scientific world. Its orbit being, however, computed by Professor Gauss, of Göttingen, it was found to have a period of 1652 days, and a mean distance from the sun expressed by 2.735, that of the earth being 1.

By comparing this distance with that given in the preceding table at which a planet was presumed to be absent, it will be seen that the object thus discovered filled the place with striking arithmetical precision.

Piazzi gave to this new member of the system the name CERES.

7. Soon after the discovery of Ceres, the planet passing into conjunction ceased to be visible. In searching for it after emerging from the sun's rays in March, 1802, Dr. Olbers noticed on the 28th a small star in the constellation of Virgo, at a place which he had examined in the two preceding months, and where he knew that no such object was *then* apparent. It appeared as a star of the seventh magnitude, the smallest which is visible without a telescope. In the course of a few hours he found its position visibly changed in relation to the surrounding stars. In fine, the object proved to be another planet, bearing a striking analogy to Ceres, and what was then totally unprecedented in the system, moving in an orbit at very nearly the same mean distance from the sun, and having, therefore, nearly the same period.

## THE NEW PLANETS.

Dr. Olbers called this planet PALLAS.

8. This circumstance, combined with the exceptional minuteness of these two planets, suggested to Olbers the startling, and then, as it must have appeared, extravagantly improbable hypothesis, that a single planet of the ordinary magnitude existed formerly at the distance indicated by Bode's analogy,—that it was broken into small fragments either by internal explosion from some cause analogous to volcanic action, or by collision with a comet,—that Ceres and Pallas were two of its fragments, and in fine, that it was very likely that many other fragments, smaller still, were revolving in similar orbits, many of which might reward the labour of future observers who might direct their attention to these regions of the firmament.

In support of this curious conjecture, it was urged that in the case of such a catastrophe as was involved in the supposition, the fragments, according to the established laws of physics, would necessarily continue to revolve in orbits, not differing much in their mean distances from that of the original planet; that the obliquities of the orbits to each other and to that of the original planet might be subject to a wider limit; that the eccentricities might also have exceptional magnitudes; and, finally, that such bodies might be expected to have magnitudes so indefinitely minute as to be out of all analogy or comparison, not only with the other primary planets, but even with the smallest of the secondary ones.

Ceres and Pallas were both so small as to elude all attempts to estimate their diameters, real or apparent. They appeared like stellar points with no appreciable disk, but surrounded with a nebulous haziness, which would have rendered very uncertain any measurement of an object so minute. Sir W. Herschel thought that Pallas did not exceed 75 miles in diameter. Others have admitted that it might measure a few hundred miles. Ceres is still smaller.

The obliquity of the orbit of Ceres to the plane of the ecliptic is above  $10\frac{1}{2}^{\circ}$ , and that of Pallas more than  $34\frac{1}{2}^{\circ}$ . Both planets, therefore, when most remote from the ecliptic pass far beyond the limits of the zodiac, and differ in obliquity from each other by a quantity far exceeding the entire inclination of any of the older planets.

It was further observed by Dr. Olbers, that at a point near the descending node of Pallas, the orbits of the two planets very nearly coincided.

Thus it appeared that all the conditions which rendered these bodies exceptional, and in which they differed from the other members of the solar system, were precisely those which were

## DISCOVERY OF JUNO AND VESTA.

consistent with the hypothesis of their origin advanced by Dr. Olbers.

9. A year and a half elapsed before any further discovery was produced to favour this hypothesis. Meanwhile, observers did not relax their zeal and their labours, and on Sept. 1, 1804, at ten o'clock, P.M., Professor Harding, of Lilienthal, discovered another minute planet, which observation soon proved to agree in all its essential conditions with the hypothesis of Olbers, having a mean distance very nearly equal to those of Ceres and Pallas, an exceptional obliquity of  $13^{\circ}$ , and a considerable eccentricity.

This planet was named JUNO.

Juno has the appearance of a star of the 8th magnitude, and a reddish colour. It was discovered with a very ordinary telescope, of 30 inches focal length and 2 inches aperture.

10. On the 29th of March, 1807, Dr. Olbers discovered another planet, under circumstances precisely similar to those already related in the cases of the former discoveries. The name VESTA was given to this planet, which, in its minute magnitude, and the character of its orbit, was analogous to Ceres, Pallas, and Juno.

Vesta is the brightest, and, apparently, the largest of all this group of planets; and, when in opposition, may be sometimes distinguished by good and practised eyes without a telescope. Observers differ in their impressions of the colour of this planet. Harding and other German observers consider her to be reddish; others contend that she is perfectly white. Mr. Hind says that he has repeatedly examined her under various powers, and always received the impression of a pale yellowish cast in her light.

11. The labours of the observers of the beginning of the century having been now prosecuted for some years without further results, were discontinued; and it is probable that but for the admirable charts of the stars which have been since published, no other members of this remarkable group of planets would have been discovered. These, however, containing all the stars up to the 9th or 10th magnitude, included within a zone of the firmament  $30^{\circ}$  in width, extending to  $15^{\circ}$  on each side of the celestial equator, supplied so important and obvious an instrument of research, that the subject was again resumed, with a better prospect of successful results. It was only necessary for the observer, map in hand, to examine, degree by degree, the zone within which such bodies are known to move, and to compare, star by star, the heavens with the map. When a star is observed which is not marked on the map, it is watched from hour to hour, and from night to night. If it do not change its position, it must be inferred that it has been omitted in the construction of the map, and it is marked upon it



## THE NEW PLANETS.

in its proper place. If it change its position, it must be inferred to be a planet, and its orbit is soon calculated from its observed changes of position.

By these means M. Hencke, an amateur observer of Driesen in Prussia, discovered, on the 8th December, 1845, another of the small planets, which has been named *ASTRÆA*.

This discovery was the signal for an extraordinary start. It had so happened that within some years several private observatories had been established, and a most respectable, intelligent, and wealthy body of amateurs and volunteers has been added to the regular professional astronomical corps. The result of this is, that within a few years a most unexpected number of planets has been discovered, all occupying nearly the same place in the system; thus, three were discovered in 1847, one in 1848, one in 1849, three in 1850, two in 1851, eight in 1852, four in 1853, and six in 1854, and one on the 6th April, 1855,—making the total number discovered to the date of writing these lines (1st May, 1855) thirty-four.

12. A tabular statement of the elements of these planets was published in the “*Annuaire du Bureau des Longitudes*” at Paris for the present year, 1855, by M. Le Verrier and his assistants. Recently, however, a much more complete table has been published by Mr. Bishop, whose observatory in the Regent’s Park has been signalled by the discovery of eleven of these thirty-four bodies. Desiring to give as wide circulation as possible to this mass of interesting astronomical data, I would refer the reader to Mr. Bishop’s table, from which I have extracted the one annexed to this notice.

To facilitate such researches, Mr. Bishop and his assistants commenced in the winter of 1846-7 the preparation of a series of charts, including all stars to those of the eleventh magnitude, within  $3^{\circ}$  of the ecliptic. “At the present moment,” says Mr. Bishop, writing in March, 1855, “fourteen maps are finished, engraved, and published to assist other observers in their search for new planetary bodies, and it is hoped to place the others before the public with no great delay.” It was in the preparation of these charts, aided by those of Berlin, that ten planets were discovered at Mr. Bishop’s observatory by Mr. Hind, and the eleventh more recently by Mr. Marth.

Mr. Bishop remarks, that during the preparation of his maps several other planets were seen, but lost again through the long-continuance of unfavourable weather, or owing to the object not having been missed at a sufficiently early period after it was entered upon the map.

Too much credit cannot be given to various astronomers,

## ZODIACAL STELLAR CHARTS.

amateur as well as professional, for the spirit and perseverance with which they have undertaken the preparation of these Zodiacal Stellar Charts. Mr. Cooper of Sligo, and his assistant Mr. Graham, are understood to be thus occupied. They have already published three volumes containing the approximate positions of more than 45000 stars. Professor De Gasparis, of Naples, and Mr. Chacornac, of Paris, are similarly engaged.

In further illustration of the table annexed to this notice, Mr. Bishop adds the following observations :—

The *fourth* column contains the estimated magnitude or degree of brightness of each planet at the time of discovery. It would appear that the four which attain the highest degree of brilliancy are Vesta (often visible without a telescope), Pallas, Iris, and Flora.

The *fifth* column gives the mean longitude for noon, Greenwich time, on the 1st of January, 1855, reckoned from the equinox of that date.

In the *sixth* is found the longitude of the perihelion, or nearest point of approach of each planet to the sun, as viewed from that luminary.

The *seventh* contains the position of the ascending node, or the point in the ecliptic where the planet passes from south to north latitude, as viewed from the sun.

The *eighth* shows the inclination of each orbit to the ecliptic, or the angle between the planes of the paths of the earth and planet. It will be remarked that Pallas, Euphrosyne, and Phoebe, have the largest inclinations, while Massilia and Themis exhibit the least; or, in other words, revolve nearly in the ecliptic.

The *ninth* column expresses the amount of excentricity or deviation from the circle. It varies from 0·075 in the case of Amphitrite to 0·346 in that of Polyhymnia.

The *tenth* gives the mean daily sidereal motion, or the space through which each planet would move in one day, if it described a circle round the sun with its average velocity. The numbers in this column multiplied by the periods expressed in days will, therefore, be equal to the circumference, or 360°.

The *eleventh* shows the mean distances from the sun, or the semi-axes major of the orbits, expressed in units of the earth's average distance from that body, and carried to two places of decimals. Flora has the least, and, according to the table, Euphrosyne the greatest; though the recent date of this planet's discovery, and consequent comparatively short extent of observation, leaves us in a little uncertainty whether its mean distance will ultimately be found to exceed that of Hygeia or Themis.

The *twelfth* shows the length of the sidereal revolution in days. The periods vary from 1193 days, that of Flora, to 2048 days, which is that of Euphrosyne; the difference amounting to 855 days, or 2½ years.

I have annexed to the table the thirty-fourth and thirty-fifth planets discovered by Mr. Chacornac and M. Luther since Mr. Bishop's table was printed. The elements of the last of these objects, however, have not yet been determined.

13. In their exceptional minuteness of volume, their mean distances from the sun, and the very variable obliquities and excentricities of their orbits, they all resemble the first four dis-

## THE NEW PLANETS.

Fig. 1.

covered in the beginning of the century, and are therefore in complete accordance with the conditions mentioned in the curious hypothesis of Olbers above stated.

The planet discovered by M. Gasparis, on the 17th of March, 1852, was observed by that astronomer at the Naples Observatory, on the 17th, 19th, and 20th March. It appeared as a star of the 10th or 11th magnitude. The observations were published in the "Comptes Rendus," of the Academy of Sciences, Paris, tome xxxiv. p. 532.

The planet discovered by M. Luther was observed by that astronomer at Bilk, near Dusseldorf, on the 17th April, and again by M. Argelander, on the 22d April, at Bonn. The observations were published in the "Comptes Rendus" of the Paris Academy, tome xxxiv. p. 647.

14. Dr. Olbers was a practitioner in medicine, Messrs. Hencke, Luther, and Goldschmidt amateur observers, Mr. Hind has been engaged in the private observatory of Mr. Bishop, in the Regent's Park, and Mr. Graham in that of Mr. Cooper, at Markree, in the county of Sligo, in Ireland. It appears, therefore, that of these twenty-three members of the solar system the scientific world owes no less than fourteen to amateur astronomers, and observatories erected and maintained by private individuals, totally unconnected with any national or public establishments, and receiving no aid or support from the state. Mr. Hind has obtained for himself the honourable distinction which must attach to the discoverer of ten of these bodies. Five are due to M. de Gasparis, assistant-astronomer at the Royal Observatory at Naples.

M. Hermann Goldschmidt is an historical painter, a native of Frankfort-on-the-Maine, but resident for the last eighteen years in Paris. He discovered the planet with a small ordinary telescope, placed in

## TOTAL NUMBER DISCOVERED.

the balcony of his apartment, No. 12, Rue de Seine, in the Faubourg St. Germain.

15. By inspecting the above table, it will be seen that these thirty-three planets move within a region of the solar system comprised between 2.2 and 3.2 times the mean distance of the earth. Their magnitudes are too minute to be ascertained with any degree of precision and certainty by any means of measurement hitherto discovered, and it may be inferred, with great probability, that they do not in general exceed 100 miles, that is, the 80th part of the diameter of the earth. Assuming, then, such to be their mean dimensions, and considering that the bulk of globes is in the proportion of the cubes of their diameters, it would follow, that, to make a globe as large as the earth, it would be necessary that 512000 such planets as these should be rolled into one.

16. It will not fail to be observed, what great probability this extreme minuteness of bulk, combined with the circumstance of their being all so nearly at the same distance from the sun, gives to the hypothesis of Dr. Olbers.

To show the relative position of this group of planets and those of the larger members of the system, we have represented in fig. 1, in their proper proportions, the successive distances of the planets from the sun, the place of these new planets being indicated by the band of parallel circles drawn in close proximity.

Being distinguished from the other planets of the system by so many singular circumstances, some astronomers denominated these bodies Asteroids; we think, however, that, for reasons that must be obvious, the name Planetoids would be preferable.

17. From the minuteness of their masses, the force of gravity on the surface of these bodies must be very inconsiderable; and this would account for a circumstance which has been observed on some of them, namely, that their atmospheres are relatively much more extensive than those of the larger planets, since the same mass of air, feebly attracted, would dilate into a volume comparatively enormous. Muscular power would be more efficacious on them in the same proportion; thus, a man might spring upwards through sixty or eighty perpendicular feet, and return to the ground, sustaining no greater shock than would be felt upon the earth in descending from the height of two or three feet. "On such planets," observes Herschel, "giants might exist, and those enormous animals which on earth require the buoyant power of water to counteract their weight." •

## THE NEW PLANETS.

Name of Planet.	Date of discovery.	Discoverer.	Magnitude.	Mean	Longitude	1855,	Longitude of Perihelion.	Long. of ascending node.	Inclination of orbit to the Ecliptic.	Eccentricity.	Mean daily sidereal motion.	Mean distance from the Sun (Earth's as unity).	Sidereal revolution in days.
			Jan. 1, at noon.	°	°	°							
Ceres .....	18 01 Jan.	Piazzi	8	340	150	81	11	0°08	12	51	2°77	1680	
Pallas .....	02 Mar.	Olbers	7	319	122	173	35	0°24	12	49	2°77	1686	
Juno .....	04 Sept.	Harding	8	210	54	171	13	0°26	13	34	2°67	1592	
Vesta .....	07 Mar.	Olbers	7	250	251	103	7	0°09	16	17	2°36	1326	
Astræa .....	45 Dec.	Hencke	9	157	136	142	5	0°19	14	18	2°58	1511	
Hebe .....	47 July	Hencke	9	283	15	139	15	0°20	15	39	2°43	1380	
Iris .....	47 Aug.	Hind	9	336	41	260	5	0°23	16	3	2°39	1346	
Flora .....	47 Oct.	Hind	9	121	33	110	6	0°16	18	6	2°20	1193	
Metis .....	48 Apr.	Graham	10	147	72	69	6	0°12	16	2	2°39	1347	
Hygeia .....	49 Apr.	Gasparis	9	207	228	288	4	0°10	10	35	3°15	2041	
Parthenope .....	50 May	Gasparis	9	317	317	125	5	0°10	15	24	2°45	1402	
Victoria .....	50 Sept.	Hind	8	51	302	236	8	0°22	16	35	2°33	1300	
Egeria .....	50 Nov.	Gasparis	9	46	120	43	17	0°09	14	17	2°58	1512	
Irene .....	{ 51 May	Hind	9	178	179	87	9	0°17	14	14	2°59	1518	
	{ „ May	Gasparis											
Eunomia .....	51 July	Gasparis	9	234	28	294	12	0°19	13	46	2°64	1570	
Psyche .....	52 Mar.	Gasparis	10	347	13	151	3	0°13	11	50	2°92	1825	
Thetis .....	52 Apr.	Luther	10	94	259	125	6	0°13	15	12	2°47	1421	
Melpomene .....	52 June	Hind	9	199	15	150	10	0°22	17	0	2°30	1271	
Fortuna .....	52 Aug.	Hind	9	209	31	211	2	0°16	15	29	2°44	1395	
Massilia .....	{ 52 Sept.	Gasparis	9	237	98	207	1	0°15	15	50	2°41	1364	
	{ „ Sept.	Chacornac											
Lutetia .....	52 Nov.	Goldschmidt	9	231	327	81	3	0°16	15	34	2°44	1388	
Calliope .....	52 Nov.	Hind	9	222	59	67	14	0°10	11	53	2°91	1817	
Thalia .....	52 Dec.	Hind	10	258	123	68	10	0°24	13	54	2°63	1554	
Themis .....	53 Apr.	Gasparis	12	279	135	36	1	0°12	10	36	3°14	2037	
Phoebe .....	53 Apr.	Chacornac	9	51	303	214	22	0°25	15	54	2°40	1355	
Proserpine .....	53 May	Luther	11	357	236	46	4	0°09	13	40	2°66	1581	
Euterpe .....	53 Nov.	Hind	9	175	88	94	2	0°17	16	27	2°35	1311	
Bellona .....	54 Mar.	Luther	10	224	122	145	9	0°15	12	48	2°78	1685	
Amphitrite .....	{ 54 Mar.	Marth											
	{ „ Mar.	Pogson	10	255	57	356	6	0°07	14	29	2°55	1491	
	{ „ Mar.	Chacornac											
Urania .....	54 July	Hind	9	10	31	308	2	0°17	16	0	2°39	1350	
Euphrosyne .....	54 Sept.	Ferguson	10	54	94	31	26	0°22	10	33	3°16	2048	
Pomona .....	54 Oct.	Goldschmidt	11	55	209	221	6	0°08	14	17	2°58	1512	
Polyhymnia .....	54 Oct.	Chacornac	10	22	340	9	2	0°35	12	5	2°88	1787	
„ .....	55 Apr.	Chacornac	11	350	188	184	5	0°07	13	41	2°65	1574	
Leucothea .....	55 Apr.	Luther											

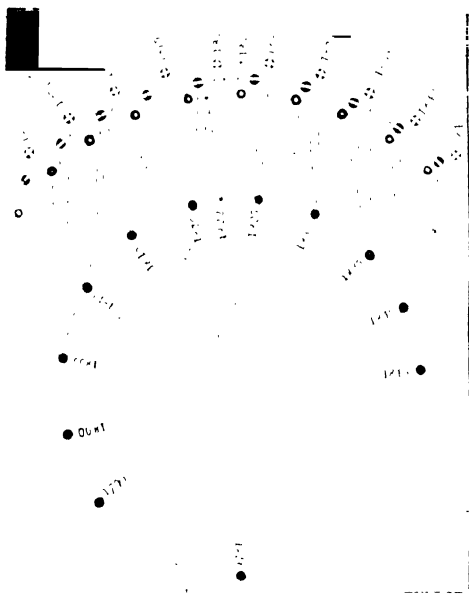

Fig. 4.

## LE VERRIER AND ADAMS' PLANET.

- 1.—Surprise excited by the discovery.—2. How a body may be discovered without seeing it.—3. Generalisation of the principle.—4. Its application to the case of Neptune.—5. Condition of the solar system before the discovery.—6. Observed disturbances of Uranus.—7. Great regularity of these effects.—8. How they would be produced by a more distant planet.—9. Calculations of Le Verrier and Adams.—10. Elements of the sought planet according to these geometers.—11. Its actual discovery.—12. Its corrected elements.—13. Discrepancies between the actual and predicted elements explained.—14. Comparison of the effects of the real and predicted planets.—15. The discovery not to be ascribed to chance.—16. The period of Neptune computed.—17. Computation of his distance.—18. Its prodigious orbital motion.—19. Illustrated by a railway train.—20. Its magnitude.—21. Its satellite.—22. Its weight.—23. Its bulk.—24. The sun's light and heat upon it.—25. The sun's apparent diameter seen from it.—26. Its suspected ring.

1. THE universal astonishment which was excited some years ago by the announcement that certain astronomers, whose names

## LE VERRIER AND ADAMS' PLANET.

till then were but little known in the scientific world, and not at all to the general public, had discovered the existence of a new planet, without ever having seen it themselves, and without its having been seen by any one else, will not be soon forgotten.

2. Nevertheless, a little reflection will show that there was not so much cause for surprise in such a discovery, as there might at first appear to be; the only cause of the surprise must depend upon the supposition, that the existence of such a body could only be ascertained by the immediate evidence of the eye directed upon it; but surely cases without number will suggest themselves to every one, in which not only the existence of bodies, but their haunts, are ascertained otherwise than by seeing them. The sportsman goes forth, attended by his hounds, in pursuit of the fox; the existence of the game is ascertained by the scent of the hounds, without seeing it, and possibly at a long distance from the place where it lies; by following closely the scent which it has left upon its track, its place of concealment is soon attained, and the game is started.

3. If we generalise the principles suggested by this familiar illustration, we shall find that it amounts to this, that the existence of a body, and the place at which it is to be found, can be ascertained with as much certainty and precision, by closely observing the peculiar effects which that body produces upon other bodies upon which it acts, and by tracing these effects, as if we actually saw the body we are in quest of. It is the peculiar nature of the fox to leave upon the ground on which he treads an odour which characterises him. The organs of the hound are so constituted as to be highly susceptible of being affected by this odour, and a sufficient number of these animals being started over the ground, they are trained to seek for the scented track, and when found to follow it. The game is thus discovered, not by the sense of sight, but by the effects which it has produced upon other bodies, which themselves affect a different sense.

4. Now let us suppose it possible, that a planet moving through the universe, which was never seen by any observer, should produce upon other planets, which are seen and observed, certain effects; that these effects can be seen and ascertained by astronomers, and that the said astronomers can infer from the general principles of their peculiar science, that these effects are such as could only be produced by a planetary body, moving at a given time in a given direction; such effects would, in that case, prove the existence of a planet, even though it were never seen. What the scent is to the hound, these effects are to the not less sagacious instincts of the astronomer.

## PERTURBATION EXPLAINED.

Such then were in fact the means by which the discovery of the planet, since called Neptune, was made; a discovery which was incontestably one of the most signal triumphs ever attained by mathematical science, and which marked an era that must be for ever memorable in the history of physical investigation.

If the planets were subject only to the attraction of the sun, they would revolve in exact ellipses, of which the sun would be the common focus; but being also subject to the attraction of each other, which, though incomparably more feeble than that of the presiding central mass, produces sensible and measurable effects, consequent deviations from these elliptic paths, called PERTURBATIONS, take place. The masses and relative motions of the planets being known, these disturbances can be ascertained with such accuracy, that the position of any known planet at any epoch, past or future, can be determined with the most surprising degree of precision.

If, therefore, it should be found, that the motion which a planet is observed to have is not in accordance with that which it ought to have, subject to the central attraction of the sun, and the disturbing actions of the surrounding planets, it must be inferred that some other disturbing attraction acts upon it, proceeding from an undiscovered cause, and, in this case, a problem novel in its form and data, and beset with difficulties which might well appear insuperable, is presented to the physical astronomer. If the solution of the problem, to determine the disturbances produced upon the orbit of a planet by another planet, whose mass and motions are known, be regarded as a stupendous achievement in physical and mathematical science, how much more formidable must not the converse question be regarded, in which the disturbances are given to find the planet.

Such was, nevertheless, the problem of which the discovery of Neptune has been the astonishing solution.

Although no exposition of the actual process by which this great intellectual achievement has been effected, could be comprehended without the possession of an amount of mathematical knowledge far exceeding that which is expected from the readers of works much less elementary than the present, we may not be altogether unsuccessful in attempting to illustrate the principle on which an investigation, attended with so surprising a result, has been based, and even the method upon which it has been conducted; so as to strip the proceeding of much of that incomprehensible character, which, in the view of the great mass of those who consider it, without being able to follow the steps of the actual investigation, is generally attached to it, and to show at least



## LE VERRIER AND ADAMS' PLANET.

Fig. 1.

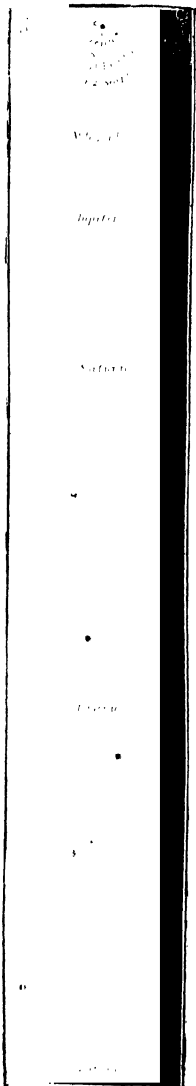

the spirit of the reasoning by which the solution of the problem has been accomplished.

For this purpose, it will be necessary, first, to explain the nature and character of those disturbances which were observed and which could not be ascribed to the attraction of any of the known planets; and, secondly, to show in what manner an undiscovered planet, revolving outside the known limits of the solar system, could produce such effects.

5. At the epoch of this celebrated discovery, the solar system was supposed to consist of the principal planets, Mercury, Venus, the Earth, Mars, Jupiter, Saturn, and Uranus, revolving round the sun, in the order in which we have given their names, and at distances bearing to each other the proportion which is represented with tolerable exactness in fig. 1. Between Mars and Jupiter a group of very minute bodies, called planetoids or asteroids, had been discovered, occupying the place of a planet, which had been supposed to be wanting in the system. Since the discovery which now engages us, the number of these planetoids discovered has been greatly increased, its amount being at the time we write (1st February, 1855,) not less than 33.

If the reader will carry in his eye the plan of the solar system thus exhibited, he will find the following observations and reasoning not difficult to comprehend.

6. The planet Uranus, revolving at the extreme limits of the solar system, was the object in which were observed those disturbances which, not being the effects of the action of any of the known planets, raised the question of the possible existence of another planet exterior to it, which might produce them.

After the discovery of that planet by Sir W. Herschel, in 1781, its motions, being regularly observed, supplied the data by

## PERTURBATION OF URANUS.

which its elliptic orbit was calculated, and the disturbances produced upon it by the masses of Jupiter and Saturn ascertained, the other planets of the system, by reason of their remoteness, and the comparative minuteness of their masses, not producing any sensible effects. Tables founded on these results were computed, and ephemerides constructed, in which the places at which the planet ought to be found from day to day for the future were duly registered.

The same kind of calculations which enabled the astronomer thus to predict the future places of the planet, would, as is evident, equally enable him to ascertain the places which had been occupied by the planet in times past. By thus examining, retrospectively, the apparent course of the planet over the firmament, and comparing its computed places at particular epochs with those of stars which had been observed, and which had subsequently disappeared, it was ascertained that several of these stars had in fact been Uranus itself, whose planetary character had not been recognised from its appearance, owing to the imperfection of the telescopes then in use; nor from its apparent motion, owing to the observations not having been sufficiently continuous and multiplied.

In this way it was ascertained, that Uranus had been observed, and its position recorded as a fixed star, six times by Flamstead: viz., once in 1690, once in 1712, and four times in 1715;—once by Bradley in 1753, once by Mayer in 1756, and twelve times by Lemonnier between 1750 and 1771.

Now, although the observed positions of these objects, combined with their subsequent disappearance, left no doubt whatever of their identity with the planet, their observed places deviated sensibly from the places which the planet ought to have had, according to the computations founded upon its motions after its discovery in 1781. If these deviations could have been shown to be irregular and governed by no law, they would be ascribed to errors of observation. If, on the other hand, they were found to follow a regular course of increase and decrease in determinate directions, they would be ascribed to the agency of some undiscovered disturbing cause, whose action at the epochs of the ancient observations was different from its action at more recent periods.

The ancient observations were, however, too limited in number and too discontinuous to demonstrate in a satisfactory manner the irregularity or the regularity of the deviation. Nevertheless, the circumstance raised much doubt and misgiving in the mind of Bouvard, by whom the tables of Uranus, based upon the modern observations, were constructed; and he stated that he

## LE VERRIER AND ADAMS' PLANET.

would leave to futurity the decision of the question, whether these deviations were due to errors of observation, or to an *undiscovered disturbing agent*. We shall presently be enabled to appreciate the sagacity of this reserve.

7. The motions of the planet continued to be assiduously observed, and were found to be in accordance with the tables for about fourteen years from the date of the discovery of the planet. About the year 1795, a slight discordance between the tabular and observed places began to be manifested, the latter being a little in advance of the former, so that the observed longitude  $L$  of the planet was greater than the tabular longitude  $L'$ . After this, from year to year, the advance of the observed upon the tabular place increased, so that the excess  $L-L'$  of the observed above the tabular longitude was continually augmented. This increase of  $L-L'$  continued until 1822, when it became stationary, and afterwards began to decrease. This decrease continued until about 1830-31, when the deviation  $L-L'$  disappeared, and the tabular and observed longitudes again agreed. This accordance, however, did not long prevail. The planet soon began to fall behind its tabular place, so that its observed longitude  $L$ , which before 1831 was greater than the tabular longitude  $L'$ , was now less; and the distance  $L'-L$  of the observed behind the tabular place increased from year to year, and still increases.

It appears, therefore, that in the deviations of the planet from its computed place, there was nothing irregular and nothing compatible with the supposition of any cause depending on the accidental errors of observation. The deviation, on the contrary, increased gradually in a certain direction to a certain point; and having attained a maximum, then began to decrease, which decrease still continues.

The phenomena must, therefore, be ascribed to the regular agency of some undiscovered disturbing cause.

8. It is not difficult to demonstrate that deviations from its computed place, such as those described above, would be produced by a planet revolving in an orbit having the same or nearly the same plane as that of Uranus, which would be in heliocentric conjunction with that planet at the epoch at which its advance beyond its computed place attained its maximum.

Let  $A B C D E F$ , fig. 2, represent the arc of the orbit of Uranus described by the planet during the manifestation of the perturbations. Let  $N N'$  represent the orbit of the supposed undiscovered planet in the same plane with the orbit of Uranus. Let  $a, b, c, d, e$ , and  $f$  be the positions of the latter when Uranus is at the points  $A, B, C, D, E$ , and  $F$ . It is therefore supposed, that Uranus

## PERTURBATION OF URANUS.

when at *D* is in heliocentric conjunction with the supposed planet, the latter being then at *d*.

The directions of the orbital motions of the two planets are indicated by the arrows beside their paths; and the directions of

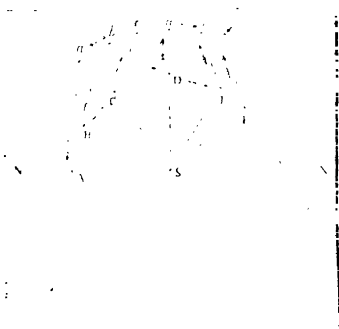

Fig. 2.

the disturbing forces \* exercised by the supposed planet on Uranus are indicated by the arrows beside the lines joining that planet with Uranus.

Now, it will be quite evident, that the attraction exerted by the supposed planet at *a* on Uranus at *A* tends to accelerate the latter. In like manner, the forces exerted by the supposed planet at *b* and *c* upon Uranus at *B* and *C* tend to accelerate it. But as Uranus approaches to *D*, the direction of the disturbing force, being less and less inclined to that of the orbital motion, has a less and less accelerating influence, and on arriving at *D*, the disturbing force being in the direction *D d* at right angles to the orbital motion, all accelerating influence ceases.

After passing *D* the disturbing force is inclined *against* the motion, and instead of accelerating retards it; and as Uranus takes successively the positions *E*, *F*, &c., it is more and more inclined, and its retarding influence more and more increased, as will be evident if the directions of the retarding force and the orbital motion, as indicated by the arrows, be observed.

\* To simplify the explanation, the effect of the attraction of Uranus on the sun is omitted in this illustration. In the chapter on Perturbations in my "Handbook on Astronomy," the method of determining the exact direction of the disturbing force is explained.

## LE VERRIER AND ADAMS' PLANET.

It is then apparent, that from A to D the disturbing force, accelerating the orbital motion, will transfer Uranus to a position in advance of that which it would otherwise have occupied; and after passing D, the disturbing force retarding the planet's motion will continually reduce this advance, until it bring back the planet to the place it would have occupied had no disturbing force acted; after which, the retardation being still continued, the planet will fall behind the place it would have had if no disturbing force had acted upon it.

Now it is evident that these are precisely the *kind* of disturbing forces which act upon Uranus; and it may, therefore, be inferred that the deviations of that planet from its computed place are the physical indications of the presence of a planet exterior to it, moving in an orbit whose plane either coincides with that of its own orbit, or is inclined to it at a very small angle, and whose mass and distance are such as to give to its attraction the degree of intensity necessary to produce the alternate acceleration and retardation which have been observed.

Since, however, the intensity of the disturbing force depends conjointly on the quantity of the disturbing mass and its distance, it is easy to perceive that the same disturbance may arise from different masses, provided that their distances are so varied as to compensate for their different weights or quantities of matter. A double mass at a fourfold distance will exert precisely the same attraction. The question, therefore, under this point of view, belongs to the class of indeterminate problems, and admits of an infinite number of solutions. In other words, an unlimited variety of different planets may be assigned, exterior to the system which would cause disturbances observed in the motion of Uranus, so nearly similar to those observed, as to be distinguishable from them only by observations more extended and elaborate than any to which that planet could possibly have been submitted since its discovery.

9. The idea of taking these departures of the observed from the computed place of Uranus, as the data for the solution of the problem to ascertain the position and motion of the planet which could cause such deviations, occurred, nearly at the same time, to two astronomers, neither of whom at that time had attained either the age or the scientific standing which would have raised the expectations of achieving the most astonishing discovery of modern times.

M. Le Verrier, in Paris, and Mr. J. C. Adams, Fellow and Assistant Tutor of St. John's College, Cambridge, engaged in the investigation, each without the knowledge of what the other was

## CALCULATIONS OF THE DISCOVERERS.

doing, and believing that he stood alone in his adventurous and, as would then have appeared, hopeless attempt. Nevertheless, both not only solved the problem, but did so with a completeness that filled the world with astonishment and admiration, in which none more ardently shared than those who, from their own attainments, were best qualified to appreciate the difficulties of the question.

The question, as has been observed, belonged to the class of indeterminate problems. An infinite number of different planets might be assigned which would be equally capable of producing the observed disturbances. The solution, therefore, might be theoretically correct, but practically unsuccessful. To strip the question as far as possible of this character, certain conditions were assumed, the existence of which might be regarded as in the highest degree probable. Thus it was assumed that the disturbing planet's orbit was in or nearly in the plane of that of Uranus, and therefore in that of the ecliptic; that its motion in this orbit was in the same direction as that of all the other planets of the system, that is, according to the order of the signs; that the orbit was an ellipse of very small eccentricity; and, in fine, that its mean distance from the sun was, in accordance with the general progression of distances noticed by Bode, nearly double the mean distance of Uranus. This last condition, combined with the harmonic law, gave the inquirer the advantage of the knowledge of the period, and therefore of the mean heliocentric motion.

Assuming all these conditions as provisional data, the problem was reduced to the determination, at least as a first approximation, of the mass of the planet and its place in its orbit at a given epoch, such as would be capable of producing the observed alternate acceleration and retardation of Uranus.

The determination of the heliocentric\* place of the planet at a given epoch would have been materially facilitated if the exact time at which the amount of the advance ( $L-L'$ ) of the observed upon the tabular place of the planet had attained its maximum were known; but this, unfortunately, did not admit of being ascertained with the necessary precision. When a varying quantity attains its maximum state, and, after increasing, begins to diminish, it is stationary for a short interval; and it is always a matter of difficulty, and often of much uncertainty, to determine the exact moment at which the increase ceases and the decrease commences. Although, therefore, the heliocentric place of the

\* That is, the place in which the planet would appear to be, if the observer were at the centre of the system, where the sun is.

## LE VERRIER AND ADAMS' PLANET.

disturbing planet could be nearly assigned about 1822, it could not be determined with the desired precision.

Assuming, however, as nearly as was practicable, the longitude of Uranus at the moment of heliocentric conjunction \* with the disturbing planet, this, combined with the mean motion of the sought planet, inferred from its period, would give a rough approximation to its place for any given time.

10. Rough approximations were not, however, what MM. Le Verrier and Adams sought. They aimed at more exact results; and, after investigations involving all the resources and exhausting all the vast powers of analysis, these eminent geometers arrived at the following elements of the undiscovered planet:—

	Le Verrier.	Adams.
Epoch of the elements . . . .	1 Jan. 1847.	1 Jan. 1846.
Mean longitude at the epoch . . .	318° 47'·4	323° 2'
Mean distance of planet from sun .	36·1539	37·2474
Eccentricity of the orbit . . . .	0·107610	0·120615
Longitude of perihelion . . . .	284° 45'·8	299° 11'
Mass (sun = 1) . . . . .	0·00010727	0·00015003

11. On the 23rd September, 1846, Dr. Galle, one of the astronomers of the Royal Observatory at Berlin, received a letter from M. Le Verrier, announcing to him the principal results of his calculations, informing him that the longitude of the sought planet must then be 326°, and requesting him to look for it. Dr. Galle, assisted by Professor Encké, accordingly did “look for it,” and found it that very night. It appeared as a star of the 8th magnitude, having the longitude of 326° 52', and consequently only 52' from the place assigned by M. Le Verrier. The calculations of Mr. Adams, reduced to the same date, gave for its place 329° 19', being 2° 27' from the place where it was actually found.

To illustrate the relative proximity of these remarkable predictions to the actual observed place, let the arc of the ecliptic, from long. 323° to long. 330°, be represented in fig. 3. The place assigned by M. Le Verrier for the sought planet is indi-

\* Two objects are said to be in heliocentric conjunction, when they are so placed that they would be seen in the same direction by an observer looking at them from the sun.

## NEPTUNE DISCOVERED.

cated by the small circle at L, that assigned by Mr. Adams by the small circle at A, and the place at which it was actually found by the dot at N. The distances of L and A from N may be appreciated by the circle which is described around the dot N, and which represents the apparent disk of the moon.

Fig. 3.

The distance of the observed place of the planet from the place predicted by M. Le Verrier was less than two diameters, and from that predicted by Mr. Adams less than five diameters of the lunar disc.

12. In obtaining the elements given above, Mr. Adams based his calculations on the observations of Uranus made up to 1840, while the calculations of M. Le Verrier were founded on observations continued to 1845. On subsequently taking into computation the five years ending 1845, Mr. Adams concluded that the mean distance of the sought planet would be more exactly taken at 33.33.

After the planet had been actually discovered, and observations of sufficient continuance were made upon it, the following proved to be its more exact elements :—

	Greenwich.
Epoch of the elements . . . . .	1 Jan. 1847, M. Noon.
Mean longitude at the epoch . . . . .	328° 32' 44"·2.
Mean distance from sun . . . . .	30·0367.
Eccentricity of orbit . . . . .	0·00871946.
Longitude of perihelion . . . . .	47° 12' 6"·50.
Longitude of ascending node . . . . .	130° 4' 20"·81.
Inclination of orbit . . . . .	1° 46' 58"·97.
Periodic time . . . . .	164·6181 years.
Mean annual motion . . . . .	2°·18688.

13. Now it will not fail to strike every one who devotes the least attention to this interesting question, that considerable discrepancies exist, not only between the elements presented in the two proposed solutions of this problem, but between the actual elements of the discovered planet and both of these solutions.



## LE VERRIER AND ADAMS' PLANET.

There were not wanting some who, viewing these discordances, did not hesitate to declare that the discovery of the planet was the result of chance, and not, as was claimed, of mathematical reasoning, since, in fact, the planet discovered was not identical with either of the two planets predicted.

To draw such a conclusion from such premises, however, betrays a total misapprehension of the nature and conditions of the problem. If the problem had been determinate, and, consequently, one which admits of but one solution, then it must have been inferred, either that some error had been committed in the calculations which caused the discordance between the observed and computed elements, or that the discovered planet was not that which was sought, and which was the physical cause of the observed disturbances of Uranus. But the problem, as has been already explained, being more or less indeterminate, admits of more than one,—nay, of an indefinite number of different solutions, so that many different planets might be assigned which would equally produce the disturbances which had been observed; and this being so, the discordance between the two sets of predicted elements, and between both of them and the actual elements, are nothing more than might have been anticipated, and which, except by a chance, against which the probabilities were millions to one, were, in fact, inevitable.

So far as depended on reasoning, the prediction was verified; so far as depended on chance it failed. Two planets were assigned, both of which lay within the limits which fulfilled the conditions of the problem. Both, however, differed from the true planet in particulars which did not affect the conditions of the problem. All three were circumscribed within those limits, and subject to such conditions as would make them produce those deviations or disturbances which were observed in the motions of Uranus, and which formed the immediate subject of the problem.

14. It may be satisfactory to render this still more clear, by exhibiting in immediate juxtaposition the motions of the hypothetical planets of MM. Le Verrier and Adams and the planet actually discovered, so as to make it apparent that any one of the three, under the supposed conditions, would produce the observed disturbances. We have accordingly attempted this in fig. 4, where the orbits of Uranus, of Neptune, and of the planets assigned by MM. Le Verrier and Adams are laid down, with the positions of the planets respectively in them for every fifth year, from 1800 to 1845 inclusively. This plan is, of course, only roughly made; but it is sufficiently exact for the purposes of the present illustration. The places of Uranus are marked by O,

## DISCREPANCIES EXPLAINED.

those of Neptune by  $\odot$ , those of M. Le Verrier's planet by  $\ominus$ , and those of Mr. Adams' planet by  $\oplus$ .

It will be observed that the distances of the two planets assigned by MM. Le Verrier and Adams, as laid down in the diagram, differ less from the distance of the planet Neptune than the mean distances given in their elements differ from the mean distance of Neptune. This is explained by the eccentricities of the orbit, which, in the elements of both astronomers, are considerable, being nearly an eighth in one and a ninth in the other, and by the positions of the supposed planets in their respective orbits.

If the masses of the three planets were equal, it is clear that the attraction with which Le Verrier's planet would act upon Uranus, would be less than that of the true planet, and that of Adams' planet still more so, each being less in the same ratio as the square of its distance from Uranus is greater than that of Neptune. But if the planets are so adjusted that what is lost by distance is gained by the greater masses, this will be equalised, and the supposed planet will exert the same disturbing force as the actual planet, so far as relates to the effects of variation of distance. It is true that, throughout the arcs of the orbits over which the observations extend, the distances of the three planets in simultaneous positions are not everywhere in exactly the same ratio, while their masses must necessarily be so; and, therefore, the relative masses, which would produce perfect compensation in one position, would not do so in others. This cause of discrepancy would operate, however, under the actual conditions of the problem, in a degree altogether inconsiderable, if not insensible.

But another cause of difference in the disturbing action of the real and supposed planets would arise from the fact, that the directions of the disturbing forces of all the three planets are different, as will be apparent on inspecting the figure in which the degree of divergence of these forces at each position of the planets is indicated; but it will be also apparent, that this divergence is so very inconsiderable that its effect must be quite insensible in all positions in which Uranus can be seriously affected. Thus, from 1800 to 1815, the divergence is very small. It increases from 1815 to 1835; but it is precisely here, near the epoch of heliocentric conjunction, which took place in 1822, that all the three planets cease to have any direct effect in accelerating the motion of Uranus. When the latter planet passes this point sufficiently to be sensibly retarded by the disturbing action, as is the case after 1835, the divergence again becomes inconsiderable.

From these considerations it will therefore be understood, that

## LE VERRIER AND ADAMS' PLANET.

the disturbances of the motion of Uranus, so far as these were ascertained by observation, would be produced without sensible difference, either by the actual planet which has been discovered, or by either of the planets assigned by MM. Le Verrier and Adams, or even by an indefinite number of others which might be assigned, either within the path of Neptune, or between it and that of Adams' planet, or, in fine, beyond the latter—within certain assignable limits.

15. That the planets assigned by MM. Le Verrier and Adams are not identical with the planet to the discovery of which their researches have conducted practical observers is, therefore, true; but it is also true that, if they or either of them had been identical with it, such excessive amount of agreement would have been purely accidental, and not at all the result of the sagacity of the mathematician. All that human sagacity could do with the data presented by observation was done. Among an indefinite number of *possible* planets capable of producing the disturbing action, two were assigned, both of which were, for all the purposes of the inquiry, so nearly coincident with the real planet as inevitably and immediately to lead to its discovery.

16. It might appear from considering merely the enormous distance of this planet from the earth, that the problem to ascertain the rate of its motion, and the time it takes to make a complete revolution round the sun, would be attended with great difficulty; nothing, on the contrary, can be more easy or simple. By observing the place of the planet with precision on any given night,—say, for example, on the 1st January, 1853,—and again on the 1st January, 1854, it will be found to have moved through  $2\cdot187^\circ$ ; we infer, therefore, that this is the rate of its annual motion; and this inference would be verified by repeating the same observation on the 1st of January, 1855, and, in a word, on the same night in each succeeding year.

Having thus ascertained that Neptune moves round the sun at the rate of  $2\cdot187^\circ$  per annum, the question is: how long he will take to make a complete revolution—that is  $360^\circ$ —round the sun; and this, it is clear, is a question in the simple Rule of Three, that can be solved by any school-boy, and is thus stated—

$$2\cdot187^\circ : 360^\circ :: 1 \text{ year} : \frac{360}{2\cdot187} = 164\cdot6 \text{ years.}$$

Thus it appears that this planet will make a complete revolution round the sun in about 164 years and 7 months, and although not more than a few years have elapsed since the date of its discovery, we are just as certain, that it will complete its revolution in that interval as our posterity will be, who will witness the completion of its period, in the year of our Lord 2011.

## DISTANCE OF NEPTUNE.

17. There is a remarkable astronomical law which was discovered, as a matter of fact, by Kepler, and shown by Newton to be a necessary consequence of the principle of universal gravitation, called the harmonic law; according to this celebrated law, the successive distances of the planets from the sun, have a certain fixed relation to their times of revolutions, shortly called their periodic times, by means of which their relative distances can be easily computed, when their periodic times are known. This celebrated law is expressed as follows:—

*The squares of the numbers which express the periodic times of any two planets, are in the same proportion as the cubes of the numbers which express their distances from the sun.*

This rule reduces the problem to determine the distance of Neptune from the sun to a question in the simple Rule of Three.

The periodic time of the earth being a year, will be expressed by 1, and that of Neptune will be, as already shown, 164·6; now the squares of these numbers are 1 and 27093. To find the cube of Neptune's distance, is therefore a Rule of Three question stated as follow:—

$$1 : 27093 :: 1 : 27093.$$

Therefore this number 27093 is in fact the cube of Neptune's distance from the sun, the earth's distance from the sun being expressed by 1. To find Neptune's distance, therefore, we have only to find the number whose cube is 27093, and by the ordinary processes of arithmetic, that number is found to be 30·034.

We may, therefore, state in round numbers, that Neptune is 30 times farther from the sun than the earth. But the distance of the earth from the sun being, in round numbers, 100 millions of miles; it follows that the distance of Neptune from the sun is, in round numbers, about 3000 millions of miles. Greater numerical precision than this has been attained by the computations of astronomers, but the purpose of our numerous readers will be best served at present by adhering to these round numbers.

18. To convey some notion of the prodigious

Fig. 5.

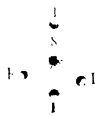

## LE VERRIER AND ADAMS' PLANET.

scale upon which the orbital motion of this planet takes place, we have represented in fig. 5, the orbit of the earth, E, E', E'', E''', the distance of E from s, the sun, being 100 millions of miles; s N will then be upon the same scale, the distance of Neptune from the sun.

Although it is easy by this expedient to convey a sufficiently exact notion of the relative distances of these planets from the sun, it is by no means so easy to acquire any adequate idea of their actual distances, or what is the same, of the scale of the solar system.

To obtain, even in the case of magnitudes infinitely less than these, any just notions, it is necessary to compare them, and, as it were, to measure them by some standard of magnitude, with which we have a practical familiarity. Let us see then, whether by such an expedient we can obtain some notion, however faint, of the scale of the solar system, at the extreme limit of which Neptune moves.

19. Every one is at this time familiar enough, with the motion of a railway train having a given speed, say, for example, 30 miles an hour; we know that in such a train, moving with that speed, stoppages included, we can go from London to Liverpool in 7 hours; in what time, let us ask, could we be transported in such a train from the sun to the earth? The distance, as already stated, is 100 millions of miles; if this be divided by 30 we shall find the number of hours which such a journey would take, this number would therefore be 3,333333 hours. If this be divided successively by 24 and by  $365\frac{1}{4}$  we shall find the number of days and of years in such a journey; the result of such a calculation in round numbers will show that such a train will take 380 years to move from the sun to the earth.

But Neptune being, as we have seen, 30 times more distant than the earth from the sun, it would take the same train an interval 30 times longer to move to that planet; we therefore arrive at the astounding conclusion that a railway-train moving constantly without stoppage would take 114000 years to move from the sun to Neptune, that is to the extreme limit of the solar system.

The circumference of a circle, whose diameter is 6000, is 18849; now since the diameter of Neptune's orbit is 6000 millions of miles, its circumference is 18849 millions of miles, and round this circumference the planet moves in 164.6 years, and it therefore moves at the rate of 114,500000 miles per year, or 313500 miles per day, or 13000 miles an hour.

Such is the colossal scale on which the movements of the system are conducted.

20. It will doubtless be asked, whether the magnitude of this

## MAGNITUDE OF NEPTUNE.

body have any proportion to such prodigious distances and motions? or whether, indeed, its magnitude at such a distance as 3000 millions of miles, can be at all ascertained? Difficult, nevertheless, as such a problem may seem, it is, on the contrary, among the most easy and simple which are presented to the astronomer.

When a powerful astronomical telescope is directed to a planet, the object which to the naked eye appears as a mere stellar point of light, is seen with a circular disc like that of the moon, but in general much smaller. The visual angle of the moon's disc is  $1800''$ ; now it is found that the visual angle of the disc of Neptune is only  $2\cdot8''$ , and, therefore, is very nearly 643 times less than the disc of the moon; but the distance of Neptune is 30 times greater than that of the sun, and the distance of the sun is 400 times greater than that of the moon. Therefore the distance of Neptune is 12000 times greater than that of the moon, consequently it will follow, that if the moon were removed to Neptune's distance, its visual angle would be 12000 times less than it is; but from what has been just stated it appears that the visual angle of Neptune is only 643 times less than that of the moon. It follows, therefore, that the actual diameter of Neptune must be greater than the actual diameter of the moon, in the proportion of 12000 to 643, or 19 to 1 very nearly. But since we know the diameter of the moon to be a little more than 2000 miles, it follows that the actual diameter of Neptune will be about 38000 miles.

This is a rough method of calculation which we have adopted to render the point familiar to those who are not accustomed to the more exact methods of astronomical calculations.

How little the result nevertheless varies from the truth, will be perceived when we state, that, according to the most exact observations and calculations of astronomers, the actual diameter of Neptune is 37500 miles.

21. A satellite of this planet was discovered by Mr. Lassell in October, 1846, and was afterwards observed by other astronomers both in Europe and the United States. The first observations then made raised some suspicions as to the presence of another satellite as well as of a ring analogous to that of Saturn. Notwithstanding the numerous observers, and the powerful instruments which have been directed to the planet since the date of these observations, nothing has been detected which has had any tendency to confirm these suspicions.

The existence of the satellite first seen by Mr. Lassell has, however, not only been fully established, but its motion, and the elements of its orbit, have been ascertained, first by the observations of M. O. Struve in September and December, 1847, and later,

## LE VERRIER AND ADAMS' PLANET.

and more fully, by those of his late relative M. Auguste Struve, in 1848-9.

From these observations it appears, that the distance of the satellite from the planet at its greatest elongation subtends an angle of 18" at the sun; and since the diameter of the planet subtends an angle of 2".8 at the same distance, it follows, therefore, that the distance of the satellite from the centre of the planet is equal to thirteen semidiameters of the latter.

The mean daily angular motion of the satellite round the centre of the planet is, according to the observations of Struve, 61°.2625, and, consequently, the period of the satellite is—

$$\frac{360}{61.2625} = 5.8763 \text{ days,}$$

or 5<sup>d</sup> 21<sup>h</sup> 1.8<sup>m</sup>, a result which is subject to an error not exceeding 5 minutes.

If the semidiameter of the planet be 18750 miles, the actual distance of the satellite is

$$18750 \times 12 = 225000 \text{ miles,}$$

being a little less than the distance of the moon from the earth's centre.

22. If it excite surprise that the dimensions of a globe so enormously distant from the earth as that of Neptune should be so exactly and so easily measured, it will not create less astonishment when we affirm that the mass of matter in that globe can be, and has been weighed, and not only weighed, but weighed with as much or even more precision than that which is attained by the chemist in the operations conducted upon the small masses of matter under his hands.

What then, it will naturally enough be asked, can be the form and structure of the balance, by which an operation so wonderful can be performed?

Let us see whether we cannot explain this.

If a mass of matter attached to the extremity of a string, the other extremity of which is attached to a fixed point, be whirled round in a circle, of which that fixed point is the centre, the string will be, as every one knows, stretched with a certain force, and that this force will be greater and greater as the velocity with which the body is whirled is increased. Now the moon whirls round the earth with just such a circular motion, and if it were connected by a string with the centre of the earth, that string would be stretched with a force depending upon the velocity of the moon's motion; but since no such string exists, something else must exist which will exercise the same force upon the moon as the string would, and that something is the earth's attraction.

## MOON OF NEPTUNE.

It is proved by theory, and verified by experiment, that the force with which the string connecting such a body with the centre would be stretched, would increase in the same proportion as the square of the velocity of the revolving body increases, other things being the same. If, therefore, the moon's velocity in whirling round the earth were twice what it is, the force with which it would react against the earth's attraction, would be four times greater than it is, and as the earth's attraction would still be the same, the moon, in that case, would escape from her orbit, and would depart to a greater distance from the earth. If, on the other hand, the moon moved with half its present velocity, the force with which it would stretch the string would be four times less than it is, and being then less than the earth's attraction upon it, the moon would fall towards the earth to a much less distance.

But since the moon neither departs to greater distances nor approaches to less distances, it follows that the attraction of the earth upon it is neither more nor less than that with which a string would be stretched which would connect the moon with the centre of the earth.

Now we have seen by what has been explained, that Neptune, as well as the earth, has a moon, and moreover, that this moon whirls round Neptune at a distance a little less than that at which our moon moves round the earth. To simplify the question, let us suppose for a moment that these distances are equal. If then Neptune's moon had the same velocity as ours, a string connecting it with Neptune would be stretched with the same force as that with which a string would be stretched connecting the moon with the earth; and since the attraction of the two planets on their respective moons is represented by the tension of such string, it would follow, in that case, that the two planets would exert equal attractions on moons revolving at equal distances from them. But since these attractions depend only on the quantities of matter in the two planets, or what is the same on their weights, it would, in that case, follow, that the weight of Neptune would be equal to that of the earth.

But Neptune's moon, instead of revolving in the same time as ours, revolves as it appears, by what has been explained, in 5·8763 days. Now we have just explained that the force with which the whirling body would stretch a string increases, other things being the same, in the proportion of the square of its velocity, and since our moon takes 27·322 days to make a complete revolution, while that of Neptune makes a revolution in 5·876 days, the velocity of the latter will be greater than that of the former in the proportion of 5876 to 27322; and consequently the forces with which they will react upon the planetary attractions which



## LE VERRIER AND ADAMS' PLANET.

hold them in their orbits will be proportional to the squares of these numbers. But the squares of these numbers, if computed, will be found to be in the proportion of  $21\frac{2}{3}$  to 1 very nearly. It would follow, therefore, that the weight of Neptune is  $21\frac{2}{3}$  times that of the earth.

But it must not be forgotten that in this calculation we have supposed that the distance of the satellite from Neptune is equal to the distance of the moon from the earth, but in fact the distance of Neptune's satellite is less than that of the moon, in the proportion of 225 to 238, and, therefore, the estimate of the mass of Neptune, computed as above, upon the supposition of the exact equality of the two distances, must be reduced in the same proportion, which would make Neptune's mass 20 times that of the earth.

This, as in the former case, is a very rough method of calculation, adopted to render familiar a problem, which, in its more exact details, would be much too difficult for any but professed astronomers perfectly to understand. By more exact methods it appears that the weight of Neptune is about 19 times that of the earth.

23. The relative bulks, or volumes, of globes being in the proportion of the cubes of their diameters, and the diameter of Neptune being 37500 miles, while that of the earth is about 7900 miles, it follows that the bulk of Neptune is about 107 times greater than that of the earth; or that 107 globes like the earth, being rolled into one, would form a planet equal to Neptune.

24. Since the brightness of the sun's light, and the warmth produced by its heat, decrease in the same proportion as the superficial magnitude of his disc decreases, and since the diameter of that disc decreases in the same proportion as the distance of the observer from the sun increases, it follows that the superficial magnitude of the sun's disc, and therefore the brightness of the light of day, and the warmth of the solar rays, will be less at Neptune than they are at the earth, in the same proportion in which the square of Neptune's distance from the sun is greater than the square of the earth's distance; and since Neptune is 30 times more distant than the earth, it follows that the brightness of day and the sun's warmth at Neptune are 900 times less than at the earth.

25. The apparent diameter of the sun, as seen from Neptune, being 30 times less than from the earth, is,

$$\frac{1800''}{30} = 60''$$

The sun, therefore, appears of the same magnitude as Venus seen as a morning or evening star.

## SOLAR LIGHT AND HEAT.

The relative apparent magnitudes are exhibited in fig. 6, at  $\epsilon$  and  $\pi$ .

It would, however, be a great mistake to infer that the light of the sun at Neptune approaches in any degree to the faintness of that of Venus at the earth. If Venus, when that planet appears as a morning or evening star, with the apparent diameter of 60", had a full disc (instead of one halved or nearly so, like the moon at the quarters), and if the actual intensity of light on its surface were equal to that on the surface of the sun, the light of the

Fig. 6.

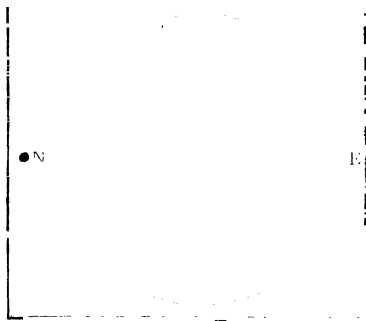

planet would be exactly that of the sun at Neptune. But the intensity of the light which falls on Venus is less than the intensity of the light on the sun's surface in the ratio of the square of Venus' distance to that of the sun's semidiameter, upon the supposition that the light is propagated according to the same law as if it issued from the sun's centre; that is, as the square of 37 millions to the square of half a million nearly, or as  $37^2 : \frac{1}{2}$ , that is, as 5476 to 1. If, therefore, the surface of Venus reflected (which it does not) all the light incident upon it, its apparent light at the earth (considering that little more than half its illuminated surface is seen) is about 11000 times less than the light of the sun at Neptune.

Small, therefore, as is the apparent magnitude of the sun at Neptune, the intensity of its daylight is probably not less than that which would be produced by about 20000 stars shining at once in the firmament, each being equal in splendour to Venus when that planet is brightest.

In addition to these considerations, it must not be forgotten that all such estimates of the comparative efficiency of the illu-

## LE VERRIER AND ADAMS' PLANET.

minating and heating power of the sun are based upon the supposition that his light is received under like physical conditions; and that many conceivable modifications in the physical state of the body or medium on or into which the light falls, and in the structure of the visual organs which it affects, may render light of an extremely feeble intensity as efficient as much stronger light is found to be under other conditions.

26. Messrs. Lassell and Challis have at times imagined that indications of some such appendage as a ring, seen nearly edgewise, were perceptible upon the disc of Neptune. These conjectures have not yet received any confirmation. When the declination of the planet shall have so far increased as to present the ring, if such an appendage be really attached to the planet, at a less oblique angle to the visual ray, the question will probably be decided.

Fig. 1.



Fig. 2.

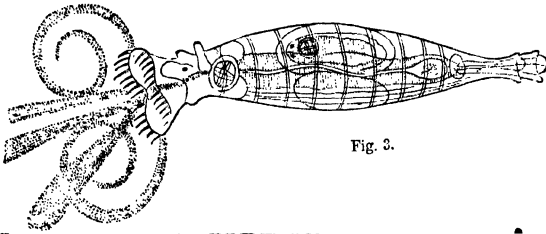

Fig. 3.

Fig. 4.

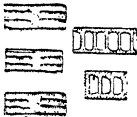

Fig. 5.



Figs. 1, 2.—TELESCOPIC VIEW OF STELLAR CLUSTERS, INCLUDING MANY MILLIONS OF SUNS REDUCED BY DISTANCE TO NEBULOUS SPOTS.  
3.—MAGNIFIED VIEW OF THE ROTIFER ANIMALCULE.  
Figs. 4, 5.—MAGNIFIED VIEW OF FOSSIL ANIMALCULES SO MINUTE THAT 187 MILLIONS OF THEM WOULD NOT WEIGH MORE THAN A GRAIN.

## MAGNITUDE AND MINUTENESS.

1. Relative magnitude.—2. Manifestations of Divine wisdom.—3. Smallness of great mountains compared with the bulk of the earth.—4. Of the earth compared with Jupiter and Saturn.—5. With the Sun.—6. With other celestial objects.—7. Minute particles of which all

## MAGNITUDE AND MINUTENESS.

bodies are composed.—8. Solid, liquid, and gaseous states—how produced.—9. Mechanical subdivision.—10. Pulverised marble.—11. Inequalities of polished surfaces.—12. Particles of gold on touchstone.—13. Filaments of glass.—14. Micrometer wires.—15. Gold leaf.—16. Gilt silver threads for embroidery.—17. Soap bubbles.—18. Insects' wings.—19. Filaments of wool, silk, and fur.—20. Red Particles in the blood.—21. Animalcules.—22. Spider's web.—23. Minute subdivision of a grain of salt.—24. Of sulphate of copper.—25. Of musk.—26. Of strychnine.—27. Of ammoniacal hyposulphite.—28. Of sugar.—29. Is matter infinitely divisible?—30. Crystallisation of salt.—31. Ultimate atoms.—32. Natural crystals.—33. Plane of cleavage.—34. Determinate figure of ultimate atoms.—35. Principles of mechanical science independent of this hypothesis.—36. Matter not destructible.—37. By combustion.—38. By evaporation.—39. By destructive distillation.—40. Nor by any other process.

1. ALL our conceptions of material objects are relative. Great and small, long and short, big and little, and such like, are words which severally have tacit reference to some standards which habit, and the things among which we live, and by which we are surrounded, have established in our thoughts. Whenever objects are presented to the senses or raised in the imagination, departing in any extraordinary degree from these familiar and habitual standards, emotions of surprise, astonishment, wonder, admiration, ridicule, pity, or contempt, according to varying circumstances, are excited. How susceptible we are of such feelings, and how peculiar is the enjoyment produced by their excitement, will be understood when it is recollected with what skill Swift has played upon them in his fiction of Gulliver, and the unbounded pleasure derived by young minds from tales of giants, dwarfs, and fairies.

2. The contemplation and study of the natural world, aided by the lights of science, disclose to us objects which soon emancipate the mind from the narrow limits imposed upon it by all those familiar and habitual standards of magnitude, and show us creative power working with equal sublimity, perfection, and wisdom, upon masses compared with which the most enormous objects around us, the most stupendous mountains, nay, the entire globe of our earth itself, dwindle into insignificant atoms; and, on the other hand, upon objects so minute as to be rendered perceptible to the senses only by extraordinary expedients supplied by the resources of science, such as the microscope. In both extremes of creation are found the same character and manifestations of infinite power, wisdom, and skill, compared with which, the greatest attainable by the most exalted human intellect are mere foolishness; benevolence of purpose, of which there appears neither end, limit, nor cessation; and grandeur of design, compared with which all

## MAGNITUDE OF SUN AND PLANETS.

speculations of philosophy, and all visions of poetry, are puerile and ridiculous.

3. We make excursions into Wales or the Scottish Highlands to enjoy the sublime spectacles of Snowdon and Ben Nevis, or to the Alps, to contemplate the stupendous masses of Mont Blanc and Mont Rosa, or to the Andes, or the Himalaya, to behold the still more enormous peaks of Chimborazo or Kunchinginga.

Now, the height of the most lofty summit of the highest of these peaks does not attain to six miles. But astronomers have demonstrated that the earth is a globe eight thousand miles in diameter, so that the height of the most lofty mountain is less than the 1300th part of the diameter.

Let us consider how such mountains should be regarded comparatively with such a globe.

Take a common terrestrial globe, for example, 24 inches in diameter. It is evident that, compared with the earth itself, 3 inches on such a globe would represent 1000 miles, and consequently 18 thousandths or the 55th part of an inch would represent six miles. A mountain six miles high would, therefore, be represented upon the surface of such a globe by a particle of dust, whose diameter would not exceed the 55th part of an inch.

If the base of a mountain six miles high measured 1000 square miles, and the form of the mountain were nearly pyramidal, its solid dimensions would amount to 2000 cubic miles. Now it will be found by the most simple calculations of arithmetic and geometry that a globe 8000 miles in diameter must consist of above 250000 millions of cubic miles. It follows, therefore, that the bulk of the earth must be more than 125 million times greater than the bulk of such a mountain.

4. The discoveries of astronomers, however, have taught us, that stupendous as the earth is when compared to such standards of magnitude, it is small when compared with other globes which in company with it revolve round the sun, and which like it, according to probabilities which amount to moral certainty, are also inhabited worlds; and that, compared with the sun itself, to say nothing of still more enormous bodies which have been discovered, it shrinks to a mere point.

Thus the bulk of the planet Saturn is nearly 900 times, and that of Jupiter nearly 1400 times that of the earth. Yet these, comparatively stupendous as they are, appear to be the theatres of the same physical phenomena, and to play the same part in the creation as the earth.\*

5. When we turn our view to the sun we encounter another

\* See our Tract on "The Planets."

## MAGNITUDE AND MINUTENESS.

order of magnitude. Astronomers have shown that that great central mass has a bulk which is nearly 1,400,000 times greater than that of the earth,\* or, in other words, that enormous as the globe of the earth is, compared with any standard of magnitude which falls under the immediate observation of the senses, it would be necessary to roll 1,400,000 such globes into one to make a globe equal to the sun.

6. Nor do we stop even here. Suns occupying positions in the universe so distant, that to our vision, even when aided by the most powerful telescopes, they appear only as luminous points, have been shown to be many times larger than ours. Comets have been observed and measured, the tails of which have a bulk hundreds of times greater than that of the sun. Clusters consisting of countless thousands of suns are brought by the telescope within our observation which exceed the magnitude, not of the sun only, but of a sun which would fill the entire solar system in a proportion to which it is impossible even to approximate.

Two of these clusters of suns which are reduced by distance to nebulous spots are shown in figs. 1 and 2, page 193.

Thus as astronomy has advanced, it has enabled us to ascend in the scale of the sublime from magnitude to magnitude, each successive discovery reducing all former standards to comparative minuteness, until the understanding and the imagination are confounded by the stupendous spectacle which the material world presents, and lost in that immensity which is the theatre of the creative and beneficent power of the Most High.

7. If our astonishment and admiration are excited by the vast scale of the stellar universe, they are not less awakened by the wonders disclosed when a minute analysis of bodies brings under our view the wonderful structure of their component parts, and the extraordinary manifestation of power and purpose in the organisation of things which would elude the senses unaided by the microscope.

The materials of bodies, even the most massive and ponderous, are infinitely minute, but, minute as they are, their particles or molecules are often formed with the most delicately exact geometrical precision. The separation of these particles, and the discovery of their forms and properties, are among the most marvellous results of scientific research.

8. Material substances are always found in one or other of three states, the solid, the liquid, and the gaseous or vaporous.

(Stones, woods, and metals are obvious examples of the solid state, water of the liquid, and air and steam of the gaseous or vaporous state.

\* See our Tract on "The Sun."

## UNLIMITED DIVISIBILITY.

Solids, generally, by means of heat applied in sufficient quantity and under fit conditions, may be made to pass into the liquid state, the process being called fusion or liquefaction, and all liquids may by like means be made to pass into the gaseous or vaporous state, the process being called vaporisation.

In like manner gases and vapours generally may, by the abstraction of heat, be made to pass into the liquid state, the process being called condensation, and liquids in like manner may be made to pass into the solid state, the process being called congelation or solidification.

In producing these changes upon particular substances, there have been practical difficulties which have prevented the success of the operation, but all analogy supports the conclusion that the principle is general.

These changes, produced by the supply and abstraction of heat, have furnished some of the most efficacious means of determining the nature and properties of the minute component parts of bodies.

9. Bodies may, however, without other physical agency than mere mechanical subdivision, be reduced to particles of surprising minuteness.

As this quality of unlimited divisibility involves conditions of the most profound interest, as well in the sciences as in the arts, we shall offer here several examples in illustration of it.

10. The most solid bodies are capable of unlimited comminution, by a variety of mechanical processes, such as cutting, filing, pounding, grinding, &c. If a mass of marble be reduced to a fine powder by the process of grinding, and this powder be then purified by careful washing, its particles, if examined by a powerful microscope, will be found to consist of blocks having rhomboidal forms, and angles as perfect and as accurate as the finest specimens of calcareous spars. These rhomboids, minute as they are, may be again broken and pulverized, and the particles into which they are divided will still be rhomboids of the same form and possessing the same character. The particles of such powder being submitted to the most powerful microscopic instruments, and the process of pulverization being pushed to the utmost practical limit, it is still found that the same forms are reproduced.

11. The polish of which the surfaces of certain bodies, such as steel, the diamond and other precious stones, are susceptible, is an evidence at once of the limited sensibility of our organs; and the unlimited divisibility of matter. This polish is produced, as is well known, by the friction of emery powder or diamond dust, and consequently each individual grain of such powder or dust must leave a little trench or trace upon the surface submitted to such friction. It is evident, therefore, that after this process has been



## MAGNITUDE AND MINUTENESS.

completed, the surface which presents to the senses such brilliant polish, and apparently infinite smoothness, is in reality covered with protuberances and indentations, the height and depth of which cannot be less than the diameter of the particles of powder by which the polish has been produced.

12. In the detection of matter in a state of extreme comminution, the sense of sight is infinitely more delicate than that of touch. If we rub a piece of gold upon a touchstone, we plainly see the particles of matter which are left upon the surface of the stone. The touch, however, cannot detect them.

13. In the preceding examples the comminution, however great, cannot be easily submitted to actual measurement. Certain processes, however, in the arts enable us to obtain exact numerical estimates of a minute divisibility, which without them might appear incredible. If a thin tube of glass, being held before the flame of a blow-pipe until the glass be softened and acquire a white heat, be drawn end from end, a thread of glass may be obtained so fine that its diameter will not exceed the two-thousandth part of an inch. This filament of glass will have all the fineness and almost all the flexibility of silk, and yet a bore proportional to that which passed through the original tube will still pass through its centre. The presence of this bore may be rendered manifest by passing a fluid through it.

It has been conjectured that if a filament of this degree of fineness could be obtained of a material that would retain sufficient inflexibility, it might be made to penetrate the flesh without producing pain or injury, inasmuch as its magnitude would be so much less than the pores of the integuments.

14. In the application of the telescope to astronomical purposes, the distance between objects which are present at one and the same time within the field of view of the instrument, is measured by fine threads which are extended parallel to each other across the field of view, and which may be moved towards and from each other until they are made to pass through the objects between which we desire to measure the distance. An experiment, then, which determines the distance between these threads measures the distance between the objects.

But these threads, being placed before the eye-glass of the telescope, and therefore necessarily magnified in the same manner as the objects themselves, would, unless such filaments were of an extreme degree of tenuity, appear in the field of view like great broad bands, and would conceal many of the objects which it might be necessary to observe. It was therefore necessary to resort to the use of filaments of extraordinary minuteness for this

## METALLIC THREADS—SOAP BUBBLE.

purpose. The threads of the web of the spider were used with more or less success; but the late Dr. Wollaston invented a beautiful expedient by which metallic threads of any degree of fineness might be obtained.

Let us suppose a piece of platinum wire, the one-hundredth of an inch in diameter, a fineness easily obtainable by the process of wire-drawing, to be extended along the axis of a cylindrical mould, the one-fifth of an inch in diameter, the wire being thus the twentieth part of the diameter of the mould. Let the mould be then filled with silver in a state of fusion. When this is cold we shall have a cylinder of silver, having in its axis a thread of platinum the twentieth part of its diameter.

This compound cylinder is then submitted to the common process of wire-drawing, during which the platinum in its centre is drawn with the silver, the proportion of their diameters being still maintained. When the wire is drawn to the greatest degree of fineness practicable, a piece of it is plunged in nitric acid, by which the surrounding silver is dissolved, and the platinum wire remains uncovered.

By this process Dr. Wollaston obtained platinum wire so fine, that thirty thousand pieces, placed side by side in contact, would not cover more than an inch.

It would take one hundred and fifty pieces of this wire bound together to form a thread as thick as a filament of raw silk.

Although platinum is the heaviest of the known bodies, a mile of this wire would not weigh more than a grain.

Seven ounces of such wire would extend from London to New York.

15. Gold is subdivided into parts of inconceivable minuteness by the gold beater. A pile of leaf gold, an inch high, would contain 280000 leaves. The thickness of each leaf would therefore be the 280000th part of an inch. Yet such leaves, used for gilding, not only produce a perfect coating of gold, but protect the article they cover from the action of external agents that might otherwise tarnish it.

16. In the manufacture of gold embroidery, threads of silver gilt are used. These threads are produced by flattening very finely drawn gilt wire. The gold which coats an inch of such a thread weighs no more than the eight millionth part of an ounce. Yet this inch may be divided into 100 parts, each of which will be visible without a microscope. In this way the eight hundred millionth part of an ounce of gold is rendered visible. But if a microscope magnifying 500 times, be used, a portion of gold, 500 times less, that is the four hundred thousand millionth part of an ounce will become visible!

## MAGNITUDE AND MINUTENESS.

17. The optical investigations of Newton disclosed some astonishing examples of the minute divisibility of matter.

A soap-bubble, as it floats in the light of the sun reflects to the eye an endless variety of the most gorgeous tints of colour. Newton showed, that to each of these tints corresponds a certain thickness of the substance forming the bubble; in fact, he showed in general, that all transparent substances, when reduced to a certain degree of tenuity, would reflect these colours.

Near the highest point of the bubble, just before it bursts, is always observed a spot which reflects no colour and appears black. Newton showed that the thickness of the bubble at this black point was the 2,500000th part of an inch! Now, as the bubble at this point possesses the properties of water as essentially as does the Atlantic Ocean, it follows, that the ultimate molecules forming water must have less dimensions than this thickness.

18. The same optical experiments were extended to the organic world, and it was shown, that the wings of insects which reflect beautiful tints resembling mother-of-pearl owe that quality to their extreme tenuity.

Some of these are so thin that 50000 placed one upon the other would not form a heap of more than a quarter of an inch in height!

19. The natural filaments of wool, silk, and fur afford striking examples of the minute divisibility of organised matter. The following numbers show how many filaments of each of the annexed substances placed in contact, side by side, would be necessary to cover an inch:—

Coarse wool . . . . .	500
Fine Merino wool . . . . .	1250
Silk . . . . .	2500

The hairs of the finest furs, such as beaver and ermine, hold a place between the filaments of Merino and silk, and the wools in general have a fineness between that of Merino and coarse wool.

All these objects are sensible to the touch.

It will be remembered that they are compound textures, having a particular structure, each containing very different elements, which are prepared by the processes of nutrition and secretion.

20. Microscopic observations have shown that blood is not as it appears to the naked eye an uniformly red liquid, but that it is a clear transparent colourless liquid, in which float countless numbers of thin, flat, red particles of a round or oval shape. The diameter of these red particles in the human blood, is the 3500th part of an inch. In certain species of animals it is much smaller, and

## FOSSIL ANIMALCULES.

measures only the 12000th of an inch. It follows from these dimensions that in a drop of human blood which would remain suspended from the point of a fine needle, there must be about 3,000000 of discs, and in a like drop of the blood of the musk-deer, there would be about 120,000000 ; yet these corpuscles are rendered not only distinctly visible to the senses by the aid of the microscope, but their forms and dimensions are rendered apparent.

21. But these globules, small as they are, are exceeded in minuteness by innumerable creatures, whose existence the microscope has disclosed, and whose entire bodies are inferior in magnitude to the globules of blood.

Microscopic research has disclosed the existence of animals, a million of which do not exceed the bulk of a grain of sand, and yet each of these is composed of members as admirably suited to their mode of life as those of the largest species. Their motions display all the phenomena of vitality, sense, and instinct. In the liquids which they inhabit they are observed to move with the most surprising speed and agility; nor are their motions and actions blind and fortuitous, but evidently governed by choice and directed to an end. They use food and drink, by which they are nourished, and must, therefore, be supplied with a digestive apparatus. They exhibit a muscular power far exceeding in strength and flexibility, relatively speaking, the larger species. They are susceptible of the same appetites, and obnoxious to the same passions, as the superior animals, and, though differing in degree, the satisfaction of these desires is attended with the same results as in our own species.

Spallanzani observes that certain animalcules devour others so voraciously that they fatten and become indolent and sluggish by over-feeding. After a meal of this kind, if they be confined in distilled water so as to be deprived of all food, their condition becomes reduced, they regain their spirit and activity, and once more amuse themselves in pursuit of the more minute animals which are supplied to them. These they swallow without depriving them of life, as by the aid of the microscope, the smaller, thus devoured, has been observed moving within the body of the greater.

An animalcule called a *Rotifer* is represented magnified in an enormous proportion in fig. 3, page 193. This creature has the appearance of throwing out before it two toothed wheels, which, being moved with prodigious velocity, produce whirlpools in the fluid in which it moves, into which other still smaller animalcules are drawn. This apparent apparatus of helical wheels, like those which propel the recently constructed steam-vessels, is supposed

## MAGNITUDE AND MINUTENESS.

to be in reality the effect of certain ciliated organs attached to the head of the animal, to which it imparts a rapid conical motion. It appears, that it has the power of drawing in these appendages, and when it does so, it changes its form from the oblong shape represented in the figure, to that of a roundish globule.

This creature possesses another property still more astonishing: when withdrawn from the liquid element which is his proper habitation, it is reduced to a grain of dust, so minute as to be visible only by the microscope. In this state it can be kept for long intervals of time, apparently deprived of all life. When, however, it is again immersed in water, it recovers all its original force, and resumes its habits. The most eminent observers have affirmed, that they have submitted the same individual rotifer, several times successively, to these alternations of life and temporary death.

The microscopic researches of Ehrenberg have disclosed most surprising examples of the minuteness of which organised matter is susceptible. He has shown that many species of infusoria exist which are so small that millions of them collected into one mass would not exceed the bulk of a grain of sand, and a thousand might swim side by side through the eye of a needle.

The shells of these creatures are found to exist fossilised in the strata of the earth in quantities so great as almost to exceed the limits of credibility.

By microscopic measurement it has been ascertained that in the slate found at Bilin, in Bohemia, which consists almost entirely of these shells, a cubic inch contains 41000,000000; and as a cubic inch weighs 220 grains, it follows that one hundred and eighty six millions of these shells must go to a grain, each of which would consequently weigh the 186,000000th part of a grain.

All these phenomena lead to the conclusion that these creatures must be supplied with an organisation corresponding in beauty with those of the larger species.

In figs 4 and 5, page 193, are represented some of the fossil animalcules found in the tripoli of Bilin, magnified in a great proportion.

22. A thread of spider's web, four miles long, weighs little more than a grain. Every one is familiar with the fact that the spider spins a thread by which its own weight hangs. It has been ascertained that this thread consists of 6000 filaments!

23. One of the most obvious means of producing a high degree of subdivision is by dissolving in a large measure of water a small portion of the substance to be divided.

## SUBDIVISION BY SOLUTION.

If a grain of salt be dissolved in 1000 grains of distilled water, each grain of the water will contain the 1000th part of the grain of salt; and if a grain of this water be mixed with 1000 grains of distilled water, the 1000th part of a grain of salt which it holds in solution will be uniformly diffused through the latter, so that each grain of the latter solution will contain the 1,000000th part of a grain of salt. The presence of the salt in this second solution can be detected by certain chemical tests.

It is evident that this process may be continued to a still greater extent.

24. A grain of sulphate of copper, dissolved in a gallon of water, will impart to the whole mass of the liquid a plainly perceptible tinge of blue; and a grain of carmine will give its peculiar tinge to the same quantity of water. It follows, therefore, that a minute drop of such water will contain such a proportion of either of these substances as the drop bears to the gallon.

25. The sense of smelling, although it does not inform us of the mechanical qualities of minute masses of matter, determines, nevertheless, their presence: thus, it is known that a grain of musk will impregnate the atmosphere of a room with its odour for a quarter of a century, or more, without suffering any considerable loss in its weight.

Every particle of the atmosphere which produces the sense of the odour must contain a certain quantity of the musk.

26. The sense of taste, like that of smelling, may determine the presence of matter, without manifesting, by direct evidence, anything concerning its mechanical qualities.

A portion of strychnine, so minute as to be scarcely perceptible to the sight, dissolved in a pint of water, will render every drop of the water bitter. Now, it is evident that in this case, the strychnine being uniformly diffused through the water, the minute portion of it above mentioned is subdivided into as many parts as there are drops of water in a pint.

27. In like manner, a single grain of the salt of silver, called ammoniacal hyposulphite, will impart a flavour of sweetness to a gallon of water. Now, a gallon of water will weigh about seventy thousand grains; and as the flavour of the salt is perceptible in each grain of the water, it follows that one grain of this salt is thus divided into seventy thousand equal parts.

28. A small lump of sugar, dissolved in a cup of tea measuring half a pint, will sweeten the whole perceptibly. In this half-pint of tea there are thirty-one thousand drops. Each drop, therefore, must contain the thirty-one thousandth part of the sugar dissolved, and each such drop is perceptibly sweet. But if the point of a needle be inserted in one of these drops, and withdrawn from

## MAGNITUDE AND MINUTENESS.

it, a film of moisture will remain upon it, and the drop will not be visibly diminished. Yet this film of moisture will still be sweet, and will, therefore, contain a fraction of the 31000th part of the lump of sugar, too minute to admit of numerical estimation.

29. It may be asked, whether we are then to conclude, from these various facts, that matter is infinitely divisible, and that there are no original constituent atoms of determinate magnitude and figure, at which all subdivision must cease. Such an inference, however, would be unwarranted, even if we had no other means of deciding the question except those of direct observation, as we should thus impose those limits on the operations of nature which she has imposed upon our powers of observing them.

Although we are unable, by direct observation, to perceive the existence of molecules, or material atoms of determinate figure, yet there are many observable phenomena which render their existence in the highest degree probable, if not positively certain.

30. The most remarkable of such phenomena are observed in the crystallization of salts.

When salt is dissolved in distilled water, as in the preceding example, the mixture presents the appearance of a transparent liquid like water itself, the salt altogether disappearing from sight and touch. The presence of the salt in the water, however, can be established by weighing the solution, which will be found to exceed the original weight of the water by the exact amount of the weight of the salt dissolved.

Now, if this solution be heated to a sufficient temperature, the water will gradually evaporate; but this process of evaporation not affecting the salt, the remaining water will still contain the same quantity of salt in solution, and it will consequently become, by degrees, a stronger and stronger saline solution, the water bearing, consequently, a less and less proportion to the salt. The water will at length be diminished, by evaporation, to that point, that a sufficient quantity does not remain to hold in solution the entire quantity of salt contained in it. When this has taken place, each particle of water which is evaporated leaving behind it the salt which it held in solution, and this salt not being capable of being dissolved by the water which remains, it will float in such water in its solid and natural state, undissolved, just as particles of dust, or other matter not soluble in the water, would do. But the saline particles which thus remain floating in the liquid undissolved, will not collect in irregular solid pieces, but will exhibit themselves in regular figures, terminated by plane surfaces, always forming regular angles, these figures being invariably the same for the same species of salt, but different for

different species. There are several circumstances attending the formation of these crystals which merit attention.

If one of these be detached from the others, and the gradual progress of its formation be submitted to observation, it will be found to grow large, always preserving its original figure. Now, since its increase must be produced by the continual accession of saline molecules, disengaged by the water evaporated, it follows that these molecules, or atoms, must have such a shape, that, by attaching themselves successively to the crystal, they will maintain the regularity of its bounding planes, and preserve the angles which these planes form with each other unvaried.

In fact, they must be so shaped, that the structure of the crystal they form may be built up by their regular aggregation into the form which it assumes.

If one of these crystals be taken from the liquid during the process of its formation, and be broken, so as to destroy the regularity of its form, and then restored to the liquid, it will be observed soon to recover its regular form, the atoms of salt, successively dismissed by the evaporating water, filling up the irregular cavities produced by the fracture.

31. Two consequences obviously follow from this phenomenon.

*First.* That the atoms of the salt dismissed by the water evaporated have such a form, as enables them, by combination, to give to the crystals the shape which they exhibit; and,

*Secondly.* That the atoms which are successively attached to the crystals in the process of formation, attach themselves in a particular position, to explain which it is necessary to suppose that corresponding sides of the crystals have attractions for each other, so that the atoms of salt not only attach themselves to the sides of the crystals, but place themselves there in a particular position. In a word, we must suppose that the walls of the crystal are built with these atoms in the same manner, and with the same regularity, as the walls of a building are formed with bricks.

All these, and many similar details of the process of crystallization, are, therefore, very evident indications of a determined figure in the ultimate atoms of the substances which are crystallized.

32. But besides these substances thus reduced by art to the form of crystals, there are large classes of bodies which naturally exist in this state.

33. There are certain planes called planes of *cleavage*, in the direction of which natural crystals are easily divided. In substances of the same kind, these planes have always the same relative position; but they differ in different substances.

The surfaces of the planes of cleavage are not always observable before the crystals are divided; but when the crystals are



## MAGNITUDE AND MINUTENESS.

divided, these surfaces exhibit an intense polish which no effort of art can equal.

We must conclude, therefore, that these planes of cleavage are parallel to the sides of the constituent atoms of the crystals, and their directions therefore form so many conditions for the determination of the shape of these atoms.

This shape being once determined, it is not difficult to assign all the various ways in which they may be arranged, so as to produce regular figures; and we accordingly find that regular figures thus indicated by mathematical reasoning correspond with the forms assumed by the crystals of the same substances.

34. It follows, therefore, from these effects, and the reasoning established upon them, that the substances which are susceptible of crystallization consist of ultimate atoms of different figure. Now, all solid bodies whatever are included in this class, for they have severally been found in, or are reducible to a crystallized form. Liquids crystallize in freezing: several of the gases have been already reduced to the liquid and solid forms, and analysis justifies the conclusion that all are capable of being reduced to this form.

Hence it appears reasonable to presume that all bodies whatever are composed of ultimate atoms, having determinate shape and magnitude; that the different qualities with which we find different bodies endued, depend upon the shape and magnitude of these atoms; that these atoms cannot be disturbed or changed so long as the body to which they belong is not decomposed into other elements, as we find the qualities which depend on them unchangeably the same under all the influences to which they have been submitted.

We must conclude also that these atoms are so minute in their magnitudes that they cannot be observed by any means which human art has yet contrived, but nevertheless that such magnitudes still have limits.

35. It is necessary, however, to observe that notwithstanding the strong analogies which support these conclusions as to the ultimate constitution of material substances, the principles of mechanical science are quite independent of them, and do not rest upon any hypothesis concerning such atomic constitution, and therefore the truth of these principles would not be in any wise disturbed even though it should be established that matter is in the most literal sense infinitely divisible, and is not formed of ultimate atoms.

The basis of mechanical science is *observed facts*; and since the reasoning upon these observed facts is demonstrative, the conclusions, when rightly deduced, have the same degree of certainty as the facts from which they are inferred.

## COMBUSTION—DESTRUCTIVE DISTILLATION.

36. The extreme division to which bodies are subjected in many natural and artificial processes, and especially when exposed to the application of heat or fire, has naturally suggested to minds not habituated to the rigid process of scientific reasoning, the idea that bodies are destructible. The ancients, instead of the modern practice of inhumation, disposed of the bodies of their dead by burning them, upon the supposition that their component parts were by such operation destroyed.

The more exact reasoning of modern philosophy, however, teaches us that a power to destroy matter would be as inconceivable in a finite agent as a power to create it.

It is certain that the quantity of matter which exists upon and in the earth has never been diminished by the annihilation of a single atom.

Matter is in fact indestructible by any agency short of divine power. It may be asked, then, what becomes of the matter composing a body which, being subjected to the action of fire, gradually and completely disappears. The answer is, that in this, as well as in all other cases of the apparent destruction of matter, nothing takes place except its subdivision and the change of its form and position.

37. When a body is subjected to the action of heat, its elements are decomposed, and its constituent particles separated, many of them combine with other particles of matter, and form new substances possessing other qualities. Thus, when coal or other fuel is burned, the carbon enters into combination with one of the constituents of the atmosphere called oxygen, and forms a gaseous substance called carbonic acid, which rises into and mixes with the atmosphere. Another element, hydrogen, combines with the same constituent of the atmosphere and forms vapor, which also disperses in the atmosphere.\*

Sulphur, which is also occasionally present in fuel, combines with the same constituent of the air, forming a gas called sulphurous acid, which also escapes into the atmosphere. Thus the entire matter of the fuel, with the exception of a small portion of incombustible matter which falls into the ash-pit, is dispersed in the air, and no destruction or annihilation takes place.

That no portion of the matter of the fuel is destroyed or annihilated can be established by the incontrovertible experimental proofs of the chemist, for by the expedients of his science all the products of the combustion which have been just mentioned can be preserved and weighed. The oxygen which has entered into combination with each element of the fuel can be

\* See our Tract on "Fire."

## MAGNITUDE AND MINUTENESS.

reproduced, as well as the constituents of the fuel itself, the latter of which being weighed, as well as the incombustible ash, the weight of the whole is found to be precisely equal to the weight of the fuel which was burned and apparently destroyed.

38. Liquids when subjected to heat are converted into vapor, and this vapor disperses in the atmosphere, so that the liquid seems to be boiled away; but if the vapor be preserved, as it may be in a separate vessel, and exposed to cold, it will return to the liquid form, and its weight and measure will be found to be precisely the same as that of the liquid evaporated.

39. There is a process in chemistry which is called destructive distillation. The term is objectionable, because it implies a destruction where no destruction takes place. If a piece of wood, being previously weighed, be placed in a close retort and submitted to what is called destructive distillation, it will be found that water, a certain acid, and several gases will issue from it, all of which may be preserved, and mere charcoal will remain in the retort at the end of the process. If the water, acid, and gases which thus escape be weighed with the charcoal, the weight of the whole will be found to be precisely equal to that of the wood which was subjected to destructive distillation.

40. Thus various forms of matter may be fused, evaporated, or submitted to combustion; animals and vegetables may die, organised bodies may be dissolved and decomposed, but in all cases their elementary and constituent parts maintain their existence. The remains of our own bodies after death are deposited in the grave, and enter into innumerable combinations with the materials of the soil, with the vegetation which covers it, and the air which circulates above it.

Consequently, these parts enter into an infinite series of other combinations, forming parts of other organised bodies, animal and vegetable, and which, after having discharged their functions, are thrown off again, mixing with the soil, the air, or organised matter, and once more running through the round of physical combinations.

The constituent atoms of matter are thus constantly performing a circle of duties in the economy of nature with infinitely more certainty and regularity than is observed in the most disciplined army or in the best regulated manufactory.

## INDEX TO VOLUMES V. AND VI.

---

- ACARUS EXULCERANS, or mange insect of horses, vi. 98 ; its form and structure, *ib.* ; mode of obtaining it, *ib.*
- Acarus scabiei, or itch insect, magnified, vi. 96.
- Achromatism of the eye, v. 53.
- Adams' and Le Verrier's simultaneous calculations, vi. 178.
- Air, less and less dense in ascending, v. 105.
- Air pump, v. 110.
- Air pump of steam engine, v. 32.
- Air thermometer, vi. 158.
- Alcohol thermometer, *ib.*
- Angular distance defined, v. 92.
- Angular motion, perception of, v. 89.
- Animalcules, amazingly small, vi. 201.
- Apparatus for raising water, worked by the weight of a man, v. 182.
- Apparent magnitude of an object, v. 61 ; to be understood as linear, not superficial, *ib.* ; nature of its variation, *ib.*
- Apparent motion, conditions which determine, v. 72 ; how affected by distance, *ib.* ; example, 73 ; when motion imperceptible, *ib.*
- Aqueous humour, v. 52.
- Arbor in watches, vi. 24.
- Aristophanes's ridicule of Meton, v. 158.
- Artificial objects, astonishing precision of certain, vi. 51.
- Asteroids, minute bulk of the, vi. 169 ; force of gravity at the surface of the, *ib.* ; thirty-three in number, 174.
- Astraea, discovery of by Hencke, vi. 166.
- Astronomers, amateur, vi. 168.
- Astronomical phenomena, time of, observed to less than the tenth of a second, v. 119 ; time, 121.
- Atmosphere, experimental proof of the weight of the, v. 97 ; of uniform density, height of an, 104 ; elastic, 105.
- Atmospheric pressure equal in all directions, v. 98 ; effects of, 106.
- Atoms, ultimate, vi. 205.
- Autumnal equinox, v. 166.
- Axis of the eye, v. 52. •
- BALANCE WHEEL in watches, vi. 26 ; its vibrations uniform, 27 ; its analogy to the pendulum, 28 ; method of regulating, 34.
- Barometer gauge in steam engine, v. 42.
- Beetle, microscopic drawing of the, vi. 81 ; its larva, *ib.* ; drawing of it in its natural size, 82 ; its production from the egg, *ib.* ; the young larva, *ib.* ; its voracity and manner of seizing its prey, 84 ; description of its organs, *ib.* ; its chrysalis, 86.
- Belgian railways, register kept on, vi. 135 ; average distance by each engine on, 138 ; work of an engine on, 140.
- Bellows, action of, explained, v. 106.
- Bevelled wheels, vi. 20.
- Bishop, Mr., his observatory and maps, vi. 166.
- Bissextile years, v. 160.
- Bladder glass, 5, 98.
- Blast pipe of locomotive, vi. 123.
- Blindness, v. 194.

## INDEX TO VOLUMES V. AND VI.

- Cooper, Mr., of Sligo, his charts of 45,000 stars, vi. 167.
- Copper, its advantage over iron for steam boilers, v. 3; minute subdivision of sulphate of, vi. 203.
- Cornea, v. 51; of a fly's eye, vi. 60.
- Counter, steam, contrived by Watt, v. 48.
- Coupled wheels of locomotives, vi. 119.
- Crown wheels, vi. 20.
- Crystalline humour, v. 52.
- Crystals of salt, vi. 204: natural, 205.
- Cuttle fish, eye of the, v. 80.
- Cylinder and piston of steam engine, v. 29.
- DAGUERRETYPES, microscopic, vi. 99.
- Dalton, Dr., his remarkable peculiarity of vision, v. 96.
- Damper in steam furnace, v. 18.
- Day, two significations of the word, v. 118; commencement of the, with different nations, 119; anciently measured from sunrise, 120; commenced by the moderns at midnight, 121; the standard unit for measuring time, *ib.*; necessity of determining it rigorously, 122; what is a, *ib.*; length of sidereal, 139.
- Day fly, its stages of existence, v. 75; its larva, 76; organs of respiration, *ib.*; general structure, 78; wonderful rapidity of its motion, *ib.*; motion of its paddles, and springing motion, 79; its second or chrysalis stage, *ib.*; the perfect insect, *ib.*; the deposition of its eggs, and its death, 80; its death delayed by postponing the laying of the eggs, *ib.*; propagation its only function in the complete stage, *ib.*; its numbers so countless that it is used for manure, *ib.*
- Days, origin of the names of the, v. 140.
- Dead plates of steam engine, v. 12.
- Dead points in action of steam engine, vi. 116.
- Decimal reckoning desirable in measuring time, v. 118.
- Defects of vision and their remedies, v. 56.
- Detached escapement, vi. 39.
- Diathermanous bodies, vi. 148.
- Differential thermometer, vi. 159.
- Dilatation, and contraction by variation of heat, vi. 146; a measure of heat, 147.
- Discovery of an unseen body, general principles of the, vi. 172.
- Distances how estimated by the eye, v. 87.
- Diurnal rotation of the heavens, v. 123; its constancy and uniformity, *ib.*; yet not fitted to be the unit of common time, *ib.*
- Divine wisdom, manifestations of, vi. 194.
- Divisibility of matter, vi. 197; question of infinite, 204.
- Donné, Dr., his atlas of microscopic anatomy and physiology, vi. 99; his lactoscope, 109.
- Double action forcing pump, v. 189.
- Drawings and engravings, minute, rendered necessary by microscopic improvements, vi. 51.
- Drebbel, air thermometer of, vi. 159.
- Driving wheels, vi. 118.
- Dry steam, v. 5.
- Duplex escapement, vi. 37.
- EARTH, its magnitude compared with that of Jupiter and Saturn, vi. 195; with the Sun, *ib.*; with other celestial objects, 196.
- Eccentric in the steam engine, v. 39.
- Effective pressure of steam, how found, v. 23.
- Egyptian months, v. 148.
- Egyptian year, v. 155; only a rude approximation to the course of the seasons, *ib.*; advantage of, 156.
- Embroidery, gilt silver threads for, vi. 199.
- Ἔτη καὶ νῆα explained, v. 149.
- Engines, low and high pressure, v. 29; more properly called condensing and non-condensing, 29; objections to the latter, and counter-vailing advantages, 29.
- Equation of time defined, v. 133;

## INDEX TO VOLUMES V. AND VI.

- explained, *ib.* ; its extreme error, 134.
- Equinoctial points, the two, v. 166 ; year 167.
- Equinox, day of the, v. 165 ; discordance between the real and ecclesiastical, v. 169.
- Equinoxes, procession of the, v. 167.
- Escapement, recoil, vi. 34 ; cylindrical, 35 ; duplex, 37 ; lever, 38 ; detached, 39.
- Escapement wheel, action of pendulum on, vi. 18.
- European railways, gross receipts of, in 1850, vi. 143 ; their mileage, 144 ; great increase since, *ib.* ; mileage of passengers and goods, *ib.*
- Exhausting syringe, v. 108.
- Eye, importance of knowing the structure and functions of, v. 50 ; description of the, 51 ; average numerical data connected with the, 53 ; its power of adaptation, 57 ; limits of this power, 58 ; its power of accommodation to various degrees of illumination, 65 ; coincidence of the optical and geometrical centres of the, 75 ; has no direct perception of distance or magnitude, 87 ; has no direct perception of form, 93 ; how this perception is obtained, *ib.*
- Eyeball of an ox, experiment with the, v. 55.
- Eyes, number of, of different insects, vi. 50.
- FACTORY** engine, description of a, v. 34.
- Fahrenheit's thermometer, vi. 155.
- Farsightedness, v. 56, 199.
- February, derivation of the word, v. 150.
- Feed of locomotive, cutting off the, vi. 123.
- Feeders, steam, self-acting, v. 7.
- Feeding apparatus, v. 3.
- Field of view, telescopic, v. 125.
- Figure inferred from lights and shadows, v. 93.
- Filaments of wool, silk and fur, vi. 200.
- Firebridge of steam engine, v. 13.
- Fire engine, v. 191.
- Fire box of locomotive, vi. 121.
- Firmament, motion of the, v. 73.
- First day of the week, v. 143.
- Fishes take air through the gills, vi. 76.
- Flies walking on ceiling explained, v. 106.
- Fluted wire used in manufacturing clockwork, vi. 19.
- Fly wheel in steam engine, v. 41.
- Forcing pump, v. 188 ; air vessel attached to, *ib.* ; solid plunger in, 189.
- Fore milk and after milk, vi. 111.
- Forked lightning, its continuous lines accounted for, v. 74.
- French railways, work of ~~each~~ engine on, vi. 138.
- Freezing point and boiling point, vi. 153.
- Frog's tongue, magnified view of part of, vi. 65 ; circulation of blood in, 103 ; microscopic examination of, distinguishing the arteries from the veins, 104 ; its vascular system, 105.
- Froment, Mr., his apparatus for the scales of astronomical instruments, vi. 53 ; surprising minuteness of his microscopic engraving, 72 ; method of executing it not yet made public, 73.
- Fuel, contrivance for supplying, to steam engine, v. 15.
- Furnace of steam engine, v. 11 ; proper mode of feeding, *ib.* ; rarely observed, 13 ; method of regulating the activity of, 18.
- Fusee in timepieces, vi. 24 ; its effect in equalising the moving power explained, *ib.*
- Fusion or liquefaction by heat, vi. 146.
- GALILEO'S** sayings respecting nature's abhorrence of a vacuum, v. 102 ; his discovery of the isochronism of the pendulum, vi. 7.
- Galle's discovery of Neptune on the night of receiving its elements from Le Verrier, vi. 180.
- Garden watering pumps, v. 191.
- Gasparis' discovery of planets, vi. 168.

INDEX TO VOLUMES V. AND VI.

- Gauge, steam, v. 9.  
 Gauges of steam power, insufficiency of certain, v. 44.  
 Glass, filaments of, vi. 198.  
 Globules and globulines of the blood, vi. 100.  
 Gnat, the, vi. 90 ; its rapid locomotion, 94.  
 Gold, particles of, on touchstone, vi. 198 ; leaf, amazing tenuity of, 199.  
 Golden number, origin of the, v. 158.  
 Goldschmidt's planetary discoveries, vi. 168.  
 Goring, Dr., his microscopic drawings, vi. 75 ; his magnified drawing of the beetle, 82 ; his method of drawing, 94.  
 Governor in the steam engine, v. 37.  
 Graham's discovery of the planet Metis, vi. 168.  
 Greek months, v. 148 ; year, 156.  
 Gregorian calendar, v. 170 ; its compensating effect, 171 ; resistance to its adoption, *ib.* ; date of its adoption in different countries, *ib.* ; its adoption in England, 172 ; popular exasperation produced by it, *ib.* ; anecdote relating to it, *ib.*  
 Gurgling noise in decanting explained, v. 108.
- HANDS of timepieces moved by tooth and pinionwork, vi. 18 ; why not turned back when clock is wound up, 22.  
 Heat, instruments for measuring, vi. 145 ; sensible, 146 ; latent, *ib.* ; some bodies pervious to, 148 ; some reflect it, *ib.*  
 Hermes Trismegistos, v. 155.  
 Herschell, telescope of, vi. 57.  
 Himalaya chain, height of, v. 105.  
 Hind, Mr. the discoverer of ten planets, vi. 166.  
 Historical dates, rectification of, v. 164.  
 Hot water pump of steam engine, v. 32.  
 Hourglass, vi. 4.  
 Hours, v. 118 ; their length in certain cases variable, 119 ; vulgar and equinoctial, *ib.*  
 Hyaloid capsule, v. 53.
- Hydrometer for testing the richness of milk, vi. 108 ; its fallacy, *ib.*
- ICELAND, most intense cold observed in, vi. 155.  
 Ides, v. 153.  
 Illumination, sufficiency of, necessary for perfect vision, v. 64.  
 Image, distinctness of optical, v. 55.  
 Incandescence, vi. 147.  
 Indicator in steam engine, v. 44 ; mode of recording its positions, 45 ; its application in finding effective force, 46.  
 Ink bottle, pneumatic, v. 107.  
 Insects, microscopic view of minute, vi. 62 ; three stages of the existence of, 75 ; structure and metamorphoses of, *ib.* ; breathe through orifices along their sides, or at the extremity of their body, 76 ; their wings, 200.  
 Intercalations of days by the pontiffs, v. 159.  
 Inversion of visible objects, v. 78.  
 Iris, v. 52 ; contraction of the, 66.  
 Isochronism of the pendulum, experimental verification of, vi. 9.  
 Italian time, v. 120 ; its inconveniences, *ib.*  
 Itch insect, the, vi. 95 ; method of obtaining it, *ib.* ; structure of, 98 ; its habits, *ib.* ; its eggs, *ib.*
- JANUARIUS, liquefaction of the blood of St., v. 173.  
 January, derivation of the word, v. 150.  
 Julian calendar, v. 159.  
 Julius Cæsar and Napoleon, resemblance of, v. 160.  
 Juno, discovery of the planet, by Harding, vi. 165. •
- KALEIDOSCOPE, origin of the word, v. 205 ; its construction, *ib.* ; its optical effect, *ib.* ; varieties of its form, 207 ; its occasional use in the arts, *ib.* •  
 Kater, Captain, invention of, vi. 5.  
 Knuckles, mode of remembering days of the month by the, v. 153.

## INDEX TO VOLUMES V: AND VI.

- LACTOSCOPE, *Donné's*, vi. 109; objections to it answered, 110.
- Lady-day, the commencement of the year in England until 1752, v. 175.
- Lardner's ophthalmometer, v. 202; application of it in selecting spectacles, 204.
- Lassell's discovery of Neptune's satellite, vi. 187.
- Latent heat, vi. 146.
- Le Verrier and Adams, calculations of, vi. 178.
- Leap years, v. 164.
- Lens, focal length of a, v. 198; varies with distance of object, *ib.*
- Lenses, effect of convex, in spectacles, v. 195; of concave, 197; with spherical or elliptical surfaces, 204.
- Lepisma saccharina, vi. 62.
- Level of water in the boiler, means of ascertaining the, v. 5.
- Lever escapement, vi. 38.
- Lifting pump, v. 181; double, worked by animal power, *ib.*
- Light, velocity of, v. 68; and shade, limit of perception of, 63.
- Lightning, why it appears as a continuous line of light, 71.
- Liquefaction and solidification by variation of heat, vi. 146.
- Locomotive, the, familiar to every eye and ear, vi. 113; qualifications for understanding its mechanism. 114; its explanation simplified, *ib.*; how propelled, *ib.*; form of, 117; dimensions of, 118; fuel used in, 122; plans and sections of, 124; table of principal parts of, 127; journal of the life of each locomotive desirable, 136.
- Locomotive stock, vi. 134; required amount of, 143.
- Locomotives, consumption of steam by, vi. 120; extraordinary speed of, 129; record of the performance and condition of, 135; cause of renewals of English, 136; require rest, *ib.*; expense of cleaning and lighting, 137; reserve engines, *ib.*; bank or assistant engines, 138; time they are kept standing, *ib.*; economy of fuel in, *ib.*; register of consumption, 139; small amount of useful service obtained, 140; comparative work of, on various lines, 142; legitimate test of comparison, 143.
- Log, ship's, mode of using, vi. 4.
- London and North Western Railway, traffic of, vi. 141.
- Long sight, explanation of the peculiarities of vision in, v. 199.
- Luminous objects, error respecting the varying brilliancy of, v. 66; intensity of their brightness, 67.
- Lunation, v. 146.
- Luther's discovery of planets, vi. 167.
- MAGDEBURG hemispheres, v. 99.
- Magnitude inferred from distance, v. 89.
- Magnitudes, how estimated by the eye, v. 88.
- Mainspring, vi. 22; its power variable, 23.
- Maintaining power of a clock moved by a weight, vi. 40; of a watch moved by a spring, 41.
- Mandl, Dr., his great work on microscopic anatomy, vi. 96.
- Mange insect of the horse, magnified view of, vi. 50.
- Marble, rhomboidal form of its minutest particles, vi. 197.
- Market gardeners, mode of raising water employed by French, v. 180.
- Marth, Mr., discovery of a planet by, vi. 166.
- Material substances always solid, liquid, or gaseous, vi. 196.
- Maternal providence of the day fly, vi. 80.
- Matter not destructible, vi. 207; by combustion, *ib.*; by evaporation, 208.
- Mean time adopted in France, v. 135.
- Measures for short intervals of time, no natural, vi. 2.
- Meniscus lens for spectacles, v. 201.
- Mercedonius, the name of the thirteenth month introduced by Numa, v. 154.
- Mercurial thermometer, vi. 149; preparation of the mercury, 150; selection of tube, *ib.*; formation of bulb, 151; how the tube is filled, *ib.*; scale applied, 152;



## INDEX TO VOLUMES V. AND VI.

- graduation of scale, 153; zero point, *ib.*; standard point, *ib.*
- Mercury, calculation of increments of volume of, vi. 155; uniformity of its dilatation, 156.
- Meridian, the, v. 124.
- Metals, their use in pyrometers, vi. 147; their different degrees of conductivity of heat, 148.
- Meton, and the Metonic cycle, v. 157; ridiculed by Aristophanes, 158.
- Metonic cycle, near accordance of the lunar phases with, v. 158.
- Micrometer screw, vi. 53.
- Micrometric threads, vi. 54.
- Microscope, improved powers of, vi. 62.
- Microscopic objects, standard measures and scales of, vi. 52; measurement of, 53; scales, minuteness of, *ib.*; tests, 61; natural tests not infallible, 66; not perfect standards, 67; drawing, various methods of, 74; drawing by squares, *ib.*; photographs, 99.
- Mileage of engines, average, vi. 136; on Belgian railways, *ib.*
- Milk, its constitution, vi. 106; of different animals, analysis of, *ib.*; magnified view of a drop of woman's, 107; its analogy to blood, *ib.*; richness of woman's, *ib.*; sanitary importance of its quality, 108; its richness ascertained, *ib.*
- Milkmen, frauds of, vi. 110.
- Mines, drainage of, v. 192.
- Minute structure of natural objects, beautiful precision of, vi. 50; particles of which all bodies are composed, 196.
- Month, the, v. 143; relation of the moon to, apparent in all languages, *ib.*; duration of the, 146; not conformable with lunar period, 147; legal meaning of the term, 154.
- Months, origin of the names of the, v. 149; technical aids to remember the length of, 152; arrangement of, under Augustus, 163.
- Moon, new and full, v. 144; exact periodic time of the, *ib.*
- Morpho-menelaus, microscopic appearance of the wings of the, vi. 55.
- Motion, objects in rapid, invisible, v. 73; perception of direction of, 90; perception of, varied by motion in the observer, 91; examples, *ib.*
- Mountains, insignificant size of the greatest when compared with the bulk of the earth, vi. 195.
- Moving power in clockwork, vi. 21.
- NEARSIGHTEDNESS, v. 56; different causes of, 59.
- Nebulae, remarkable, described by the Herschells, vi. 58; differently seen by Lord Rosse, 59.
- Nebulae and stellar clusters, vi. 56; effects of different telescopes upon their appearance, 57.
- Neptune, discovery of, vi. 171; its discovery one of the most signal triumphs of mathematics, 173; tables of its elements calculated by Le Verrier and Adams separately before its discovery, 180; table of corrected elements of, 181; discrepancies of actual and predicted elements explained, 181; its period computed, 184; its distance, 185; its prodigious orbital motion, *ib.*; illustrated by a railway train, 186; its magnitude, *ib.*; its satellite, 187; its weight, 188; its bulk compared with that of the earth, 190; the sun's light and heat on it, *ib.*; the sun's apparent diameter as seen from it, *ib.*; its suspected ring, 192.
- Nobert's test plates, vi. 67; the degree of closeness of their lines, 68; their use in determining the power of microscopes, 70; apparent error respecting them, *ib.*
- Nones, v. 152.
- Numa, additional months of, v. 150; brings the solar year into coincidence with the seasons, 153.
- OCULAR spectra, v. 77.
- Odd numbers, superstition in favour of, v. 151.
- Olbers's conjecture respecting a broken planet, vi. 164; corroboration of

## INDEX TO VOLUMES V. AND VI.

his theory respecting the asteroids, 167.

Old style, adhesion of Russia to, v. 173.

Ophthalmometer invented by Dr. Lardner, v. 202.

Optic nerve, v. 53; insensible to light, 79.

Optical axis, v. 53; toys, 75; toy depending on two reflections, 207.

Oscillation of the pendulum, 69; centre of, 14.

PALLAS discovered by Olbers, vi. 163.

Parallel motion in steam engine, v. 41.

Paris, former irregularity of the clocks of, v. 135.

Pascal's atmospheric experiment at Rouen, v. 100; experiment on the Puy de Dôme, 104.

Patterns for carpets suggested by the Kalcidoscope, v. 207.

Pendulous mass, analysis of motion of, vi. 12.

Pendulum, regulating power of the, vi. 6; uniform rate of its vibration, 7; number of vibrations depends on its length, *ib.*; simple, 8; moving power sustains the vibration of the, 10; vibration not dependent on weight of, *ib.*; time of vibration varies with length of, *ib.*; how it governs the hands of a clock, 14; produces uniform motion, 16; its motion maintained by moving power, *ib.*; action of, on escapement wheel, 18; how its vibrations are rendered more or less rapid, 32.

Periscopic spectacles, v. 201.

Photographic pictures self-engraved, vi. 111.

Photographs, microscopic, vi. 99.

Pinion, wheel so called, vi. 19; leaves of, *ib.*

Pinion wire for clockwork, vi. 19.

Pinions, method of making, vi. 19.

Piston, estimate of the force of moving, v. 21; transmission of this force, *ib.*; how to compute the force of, 43.

Piston rod, v. 21; its action on

wheels, vi. 115; unequal action, 116; how remedied, *ib.*; connection of, with wheels, 117.

Pistons, metallic, v. 20.

Planet, missing, between Mars and Jupiter, vi. 163.

Planets, discovery of the new, vi. 161; numerical law of their distances from the sun, 162; rapid discovery of numerous, 165; tabular statement of the elements of the new, 166.

Play of the eye, limit of the, v. 53.

Podura, or Spring-tail, microscopic view of, vi. 63.

Polished surfaces, inequalities of the most highly, vi. 197.

Pontiffs, mistake of the Roman, respecting the Calendar, v. 163.

Precession of the Equinoxes, v. 167.

Pressure of steam, how explained, v. 9; of air in a room explained, 98; of atmosphere ascertained, 104.

Priming, steam, v. 5.

Pump-dale, v. 192.

Pupil, of the eye, v. 52; contraction of the diameter of, 58.

Pyrometers, vi. 147.

QUEVENNE'S hydrometer applied to milk, vi. 108.

Quintilis, the ancient name of July, v. 150.

RADIATION of heat, vi. 148.

Rarefaction, rate of, v. 108.

Ratchet wheels in clockwork, vi. 22.

Rate of clocks and watches, method of regulating, vi. 31.

Rays, parallel, v. 55.

Reaumur's thermometer, vi. 155.

Recoil escapement, vi. 34.

Relative magnitude, how the mind is affected by, vi. 194.

Respiration, v. 106; performed by different animals differently, vi. 76.

Retina, v. 52; magnitude of image on the, 60; diminutiveness of picture on the, 63; requires a certain duration of the image to produce

INDEX TO VOLUMES V. AND VI.

- perception, 68 ; illustrations, *ib.* ; duration of impressions on the, 74.
- Riveting boiler plates, mode of, v. 3.
- Robinson Crusoe's reckoning of time, v. 116.
- Roman custom of counting time backwards, v. 153.
- Roman months, v. 149 ; year, 158.
- Rome, time measured in summer by sun-dials, in winter by clepsydras in ancient, vi. 4.
- Romulus, year established by, v. 149 ; unequal lengths of the months instituted by, 151.
- Rosce, Lord, astonishing powers of the telescope of, vi. 57.
- Rotifer, animalcule called, vi. 201.
- Russia's adherence to the old style, v. 173.
- Rutherford's self-registering thermometer, vi. 157.
- SAFETY VALVE, v. 9 ; a second one usually provided, *ib.* ; numerous forms of it, *ib.*
- Saint Peter's at Rome, optical illusion in, v. 89.
- Salt, minute subdivision of a grain of, vi. 202.
- Sanguineous corpuscles, organised, vi. 100.
- Scales, microscopic, vi. 52 ; method of engraving them, *ib.* ; rectangular, to measure length and breadth, 54.
- Sclerotic coat of the eye, v. 51.
- Seasons, discordance of the Roman year with the, v. 153.
- Seaward's slides, v. 26.
- Sectional drawings of the locomotive, vi. 125.
- Self-adjustment in the eye, v. 57.
- Seven, superstitions connected with the number, v. 143.
- Sextilis, the ancient name of August, v. 150.
- Shadows, approximative expedient for measuring time by, vi. 2.
- Short sight, explanation of the peculiarities of vision in, v. 198.
- Sidereal day, v. 127 ; unfit for a measure of time, 128 ; year, 167.
- Sight, defective, v. 194 ; short, and long or weak, 195.
- Silver fish, or Silver lady, microscopic view of its scales, vi. 62.
- Simple notions difficult to define, v. 114.
- Skin, microscopic view of the human, vi. 95 ; its sudoriferous glands and ducts magnified, *ib.*
- Smoke of steam engine, consumption of, v. 16.
- Soap bubbles, tenuity of, vi. 200.
- Solar diurnal phenomena, not a fit measure of time, v. 128.
- Solar hours, minutes, and seconds, mean, v. 139.
- Solon's months, v. 149.
- Sothic period, v. 156.
- Southern, Mr., invention of, for measuring steam-pressure, v. 46.
- Spectacles the most universally useful gift of optical science, v. 195 ; hence their principles should be universally understood, 194 ; composed of convex or concave lenses, 195 ; mounting of, 199.
- Spectra, ocular, v. 77.
- Spider's web, vi. 202.
- Standard points in thermometer, vi. 153.
- Standard thermometer, vi. 156.
- Stars, seven classes of the fixed, v. 67 ; multiple, vi. 56.
- Steam, how made to produce a mechanical effect, v. 19 ; to the cylinder, supply of, 23 ; by valves, *ib.* ; by slides, 25.
- Steam boiler, tubes through, vi. 121.
- Steam engine, the, v. 2 ; consists of two essential parts, *ib.* ; comparative merit of the two kinds of, 33 ; various methods of transmitting force in, 34 ; evaporating power of boiler determines efficiency of, vi. 120.
- Stewart, Dugald, optical peculiarity of, v. 96.
- Stokers, v. 14.
- Straw-coloured gnat, vi. 94.
- Striking apparatus in timepieces, vi. 45 ; train, *ib.*
- Strippings, a name used for after-milk, vi. 111.
- Stroke of the piston, v. 23.

## INDEX TO VOLUMES V. AND VI.

- Strychnine, particle of, vi. 203.
- Stuffing box, in steam engine, v. 21.
- Style in England, old and new, v. 175 ; temporary inconvenience attending on, 176.
- Styles, occasional agreement of the new and old, v. 172 ; anecdotes relating to the change of, 173.
- Subdivisions of matter, examples of minute, vi. 202.
- Sucker, plaything called a, v. 106.
- Suction, weighing a column of air by, v. 100 ; pump, 185 ; analysis of its action, *ib.*
- Sun, means of observing the diurnal motion of the, v. 124.
- Sun and moon, equal apparent magnitude of the, v. 62 ; their appearance when rising and setting, 88 ; apparent magnitudes of, vary, 90.
- Sun-dials, vi. 2 ; differently constructed in different latitudes, 3 ; earliest, 4.
- Sun's transits, how to observe the, v. 129 ; interval between them variable, 130.
- Siphon gauge in air pump, v. 111.
- Syringes, exhausting and condensing, v. 108.
- TRAPDOOR, lid of, reason for perforating, v. 107.
- Telescope magnifies apparent motions of objects as well as their magnitude, v. 126.
- Telescopic tests, vi. 56 ; stars, 67.
- Temperature, vi. 147 ; measured by thermometer and pyrometer, *ib.* ; best measured by dilatation and contraction of bodies, 149.
- Tender of locomotive, vi. 123.
- Test objects, vi. 56.
- Tests, microscopic, necessity for, vi. 55.
- Thaumatrope, the, v. 75.
- Thermometers, mercury, alcohol, and air, serve for, vi. 147 ; different units adopted in the graduation of, 155 ; range of the scale of, 157 ; why mercury employed in, *ib.* ; self-registering, *ib.*
- Thermometric standards, arbitrary, vi. 153.
- Thermoscopic bodies, vi. 147.
- Time, conception of, how obtained, v. 114 ; connected with the succession of our thoughts, 115 ; this succession indispensable to our conception of time, *ib.* ; passes faster with some than with others, 116 ; is measured only by regular and uniform succession, 117 ; periodic phenomena which may measure, *ib.* ; celestial luminaries intended to measure, *ib.* ; mean and apparent, 132 ; relative changes of them, *ib.* ; days on which they coincide, 133 ; unfitness of apparent for civil purposes, 136 ; local, varies with longitude, *ib.* ; equalisation of local proposed, *ib.*
- Time gauge, mercurial, for measuring fractions of a second, vi. 5.
- Time measurers, general want of, vi. 1.
- Timepieces, how regulated, v. 137 ; weight or mainspring and pendulum or balance wheel variously combined in, vi. 43.
- Toccare il tempo*, v. 120.
- Toricelli's experiment, v. 102.
- Tracheæ of insects, vi. 76 ; their ramifications along the legs, antennæ, &c., *ib.*
- Transformation of the gnat under the microscope, vi. 93.
- Transit instrument, v. 125 ; method of observing with it, 126.
- Tropical year, v. 167.
- URANUS, the first planet discovered in modern times, vi. 162 ; perturbations of, 173 ; frequently recorded as a fixed star before it was found to be a planet, 175 ; the regularity of its perturbations led to the discovery of Neptune, 176.
- Ultimate atoms, determinate figure of, vi. 206.
- VACUUM, dogma that nature abhorred a, v. 101 ; absolute, cannot be obtained, 109 ; but may be indefinitely approached, 110.
- Vague year, v. 156.

## INDEX TO VOLUMES V. AND VI.

- Valve, safety, v. 9.
- Valves, in pumps, various forms of, v. 182; conical spindle, 184; ball valves, *ib.*; in insects, beautiful action of the, vi. 78.
- Vaporisation and condensation by variation of heat, vi. 146.
- Vent peg, effect of, explained, v. 107.
- Vernal equinox, v. 166.
- Vesta, discovery of, by Olbers, vi. 165; colour of, *ib.*
- Vibration of the pendulum, analysis of a, vi. 8.
- Visibility of motion depends on angular velocity, v. 72; requires an angular velocity of one degree per minute, 73.
- Visible objects, why they do not appear inverted, v. 78; area defined, 93.
- Vision, pleasures and advantages of, v. 49; how caused, 54; conditions of perfect, 55; causes of defective, 59; impressions of, analogous to those of hearing, 68, 69; seat of, 79; why not double, 81; exceptional cases, 84; how effected, 194; remedy for defective, 195; both eyes have not always the same power of, 201; curious defects of, 204.
- Vitreous humour of the eye, v. 52.
- WAFERS, optical experiment with coloured, v. 77.
- Waggon boiler, v. 11.
- Watch, general explanation of a, vi. 28.
- Water, earliest methods of raising, v. 177; animal power applied to raising, 180; the rope in this case balances itself, 180.
- Water level in the boiler of engine, importance of keeping a proper, v. 4.
- Water beetle, the, vi. 86; its ferocity, *ib.*
- Water clock constructed by the ancients, vi. 4.
- Water devil, the, vi. 82.
- Watt, remarkable geometrical intuition of, v. 41; inexhaustible resources of his genius, 44.
- Weaksightedness, v. 56.
- Week, the, v. 139; opinions as to its origin, *ib.*; errors of those opinions, 140; in general use among the ancient Chinese as well as other orientals, 140; not employed by the Romans till the time of Theodosius, *ib.*
- Weight applied as a moving power in clock work, vi. 21.
- Wet steam, v. 5.
- Wheel and pinion, vi. 20.
- Wheel carriages, two modes of propelling, vi. 114.
- Wheels, inverse action of toothed, vi. 19; of locomotive, turn with their axles, 117.
- White of the eye, v. 51.
- White heat, vi. 147.
- Wire drawing, inconceivably minute, vi. 199.
- Wollaston, Dr., his suggestion respecting spectacles, v. 201.
- Woman's milk, its butter globules greater in quantity than in other mammals, vi. 107; researches of French physiologists respecting, 111.
- YEAR, difficulty of subdividing the, v. 147; division of, unequal, *ib.*; various modes of understanding the term, 154; sidereal, 166; equinoctial or tropical, 167; mean solar or civil, 168; difference between it and the Julian year, *ib.*; effect of this difference, *ib.*; commencement of the, 174; various in different countries, *ib.*; in England, 175.



LONDON, July, 1855.

## WORKS

PUBLISHED BY

# WALTON AND MABERLY,

UPPER GOWER STREET, AND IVY LANE, PATERNOSTER ROW.

**THE Chinese Rebel Chief Hung-siu-tsuen; His History, and the Origin of the Present Insurrection.** By the Rev. THEODORE HAMBERG, Hong-Kong. Edited by GEORGE PEARSE, Foreign Secretary of the Chinese Evangelisation Society. Foolscep 8vo, 1s. 6d. cloth.

The *Friend of China* contains a Review of this narrative, attributed to the Bishop of Victoria, Hong Kong, in which it is said—"The author's well-known caution, truthfulness, and candour, give to the little volume under review an interest and a reality which we miss while perusing the flighty, groundless theories and statements hazarded in such works as those by MM. YVAN and CALLERY. . . . The author had with him in his own house a prominent agent in the events narrated, and kinsman of the Insurgent Chief."

**London Quarterly Review, No. VIII.,** Price 6s., for July, contains—  
1. Influence of the Reformation upon English Literature.—2. Robert Newton.—3. Animal Organisation.—4. The Principle of Religious Intolerance.—5. The Science and Poetry of Art.—6. Chemical Researches in Common Life.—7. The Protestants of France.—8. The West-India Question.—9. Liberia. Brief Literary Notices.

**Far above Rubies.** A MEMOIR OF HELEN S. HERSHELL. By her Daughter. Edited by the Rev. RIDLEY H. HERSHELL. Foolscep 8vo, 6s. 6d. cloth.

\* \* \* The Volume also contains the "Bystander," a Series of Papers by Mrs. Hershell, on the following subjects:—1. Introductory.—2. Education.—3. The Law of Consideration.—4. The Deserted Village.—5. Sectarianism.—6. High Church Principles.—7. Love.—8. Elmwood.—9. Spiritual Declension.—10. The Fête.—11. Party Spirit.—12. Training Children.—13. Home Education.—14. An Amusing Companion.—15. Christian Benevolence.—16. Special Providence.—17. Moral Influence.—18. Christian Society.—19. Human Responsibility.

**A Memoir of the Rev. James Crabb, LATE OF SOUTHAMPTON.** THE "GIPSY ADVOCATE." By JOHN RUDALL, of Lincoln's Inn, Barrister-at-Law. One Vol., Crown 8vo. With a Portrait on Steel. 6s. cloth.

"The Author has presented us with a faithful portraiture of Mr. Crabb's life, character, persevering labours, and never-tiring zeal in the service of his Divine Master."—*Hampshire Independent*.

**The Jews.** A Brief Sketch of their Present State and Future Expectations. By RIDLEY H. HERSHELL. Ninth Thousand. Foolscep 8vo, 1s. 6d.

**The Crystal Palace.** An Essay Descriptive and Critical. From the London Quarterly Review. 8vo, 1s.

## EMBOSSSED BOOKS FOR THE BLIND.

By MR. FRERE.

### OLD TESTAMENT.

Genesis, 8s.—Exodus, 7s.  
Joshua, 4s. 6d.—Judges, 4s. 6d.  
Samuel I., 6s.—Samuel II., 5s. 6d.  
Job, 5s.—Proverbs, 5s. 6d.  
Psalms, Part I., 6s. 6d.  
Psalms, Part II., 5s. 6d.  
Isaiah, 7s. 6d.  
Daniel, Esther, and Ruth, 5s. 6d.  
Morning Prayers, 2s.  
Shepherd of Salisbury Plain, 2s.  
Oincy Hymns, 2s.

Art of Teaching to Read by Elementary Sounds, 1s. 6d.

### NEW TESTAMENT (In 8 Vols.).

Matthew, 6s.  
Mark, 5s. 6d.  
Luke, 7s.  
John, 5s. 6d.  
Acts, 7s.  
Romans to Corinthians, 6s.  
Galatians to Philemon, 5s. 6d.  
Hebrews to Revelations, 7s.  
A Grammar, 1s.  
Five Addresses to those who wish to go to Heaven, 1s. 6d.

## JURISPRUDENCE.

**ELEMENTS of Jurisprudence.** By CHARLES JAMES FOSTER, M.A., LL.D., Professor of Jurisprudence in University College, London. Crown 8vo, 5s. cloth.  
 "Mr. Foster treats his subject in a masterly manner, and his volume may be read with profit both by students and men of the world."—*Athenaeum*.

## RHETORIC.

**ELEMENTS of Rhetoric; A Manual of the LAWS of Taste, including the Theory and Practice of Composition.** By SAMUEL NEIL, Author of "The Art of Reasoning." Large 12mo, 4s. 6d. cloth.

## LOGIC.

**THE Art of Reasoning; A Popular Exposition of the Principles of Logic, Inductive and Deductive, with an Introductory Outline of the History of Logic, and an Appendix on Recent Logical Developments.** By SAMUEL NEIL. Crown 8vo, 4s. 6d.

"This work is of undoubted merit. It displays a great thoughtfulness and research, and contains a vast amount of useful information on the subject of which it treats. The author seems to have thoroughly mastered his subject, and to the illustration of it has skilfully applied his extensive and varied knowledge."—*Glasgow Constitutional*.

**An Investigation of the Laws of Thought, on which are founded the Mathematical Theories of Logic and Probabilities.** By GEORGE BOOLE, Professor of Mathematics in Queen's College, Cork. One Vol. 8vo, 14s. cloth.

**Formal Logic; or, the Calculus of Inference necessary and PROBABLE.** By AUGUSTUS DE MORGAN, Professor of Mathematics in University College, London. Cheap Issue, 8vo, 6s. 6d.

## HISTORY, ANTIQUITIES, &c.

**DICTIONARY of Greek and Roman Geography.** Edited by WILLIAM SMITH, LL.D., Editor of the Dictionaries of "Greek and Roman Antiquities," and of "Biography and Mythology." With very numerous Illustrations on Wood. Volume 1. (1100 pages), 11. 16s. cloth lettered.

The Work is continued in Quarterly Parts, each 4s., and will be completed in Two Volumes. Part 12 is now ready (April 1, 1855).

**Dictionary of Greek and Roman Biography and Mythology.** Edited by WILLIAM SMITH, LL.D., Classical Examiner in the University of London. Medium 8vo. Illustrated by numerous Engravings on Wood. Complete in Three Vols., 5l. 15s. 6d.

**Dictionary of Greek and Roman Antiquities.** By various Writers. Edited by Dr WILLIAM SMITH. Second Edition. Revised throughout, with very numerous Additions and Alterations. One thick Volume, medium 8vo, with several hundred Engravings on Wood, 2l. 2s.

**A New Classical Dictionary of Ancient Biography, Mythology, AND GEOGRAPHY.** Edited by Dr. WILLIAM SMITH. New Edition. One Volume, 8vo, 15s. cloth.

This work comprises the same subjects as are contained in the well-known Dictionary of Lemprière, avoiding its errors, supplying its deficiencies, and exhibiting in a concise form the *results* of the labours of modern scholars. It will thus supply a want that has been long felt by most persons engaged in tuition.



- A Smaller Dictionary of Antiquities;** Selected and Abridged from the "Dictionary of Greek and Roman Antiquities." By WILLIAM SMITH, LL.D. New and Cheaper Edition. One small Volume, Two Hundred Woodcuts, 7s. 6d. cloth.
- A Smaller Classical Dictionary.** Abridged from the larger work. By Dr. WILLIAM SMITH. Cheaper Edition. Two Hundred Woodcuts, Crown 8vo, 7s. 6d. cloth.
- The Odes of Horace,** translated into Unrhymed Metres. With Introductions and Notes. By F. W. NEWMAN, Professor of Latin, University College, London. Crown 8vo. 5s. cloth.
- Niebuhr's History of Rome, from the Earliest Times to the FALL OF THE WESTERN EMPIRE.** Translated by BISHOP THIRLWALL, ARCHDEACON HARE, Dr. WILLIAM SMITH, and Dr. SCHMITZ. Fourth and Cheaper Edition. Three Vols. 8vo, 36s.
- Niebuhr's Lectures on Roman History.** Translated and Edited by LEONHARD SCHMITZ, Ph. D., Rector of the High School of Edinburgh. New and Cheaper Edition, in Three Vols. 8vo, 24s.
- Niebuhr's Lectures on Ancient History,** comprising the Asiatic Nations, the Egyptians, Greeks, Carthaginians, and Macedonians. Translated by Dr. L. SCHMITZ. Three Vols. 8vo, 11. 11s. 6d.
- In reference to Babylonia, Assyria, and Egypt, it is particularly interesting to notice how clearly the historian foresaw and anticipated all the great discoveries which have since been made in those countries. A thousand points in the history of ancient nations, which have hitherto been either overlooked or accepted without inquiry, are here treated with sound criticism and placed in their true light.
- Niebuhr's Lectures on Ancient Ethnography and Geography.** Comprising Greece and her Colonies, Italy, the Islands of the Mediterranean, Spain, Gaul, Britain, Northern Africa, and Phœnicia. Translated from the German by Dr. LEONHARD SCHMITZ, F.R.S.E., Rector of the High School of Edinburgh, with additions and corrections from his own Notes. Two Vols. 8vo, 11. 1s. cloth.
- A History of Rome; from the Earliest Times to the Death of COMMODUS, A.D. 192.** By Dr. L. SCHMITZ, Rector of the High School of Edinburgh, Editor of "Niebuhr's Lectures." New Edition. With 100 Illustrations on Wood. One thick Vol. 12mo, 7s. 6d. cloth.
- Questions on Schmitz's History of Rome.** By JOHN ROBSON, B.A. 12mo, 2s. cloth.
- A History of Greece.** With Supplementary Chapters on the Literature, Art, and Domestic Manners of the Greeks. By William Smith, LL.D., Editor of the Dictionaries of "Greek and Roman Antiquities," "Biography," &c. Woodcuts and Maps. Post 8vo, 7s. 6d. cloth.
- "A good plan capitally executed, is the characteristic of Dr. Smith's introductory History of Greece."—*Spectator*.
- The Book of Almanacs.** With Index, by which the Almanac belonging to any year preceding A.D. 2000 can be found; with means of finding New and Full Moons from B.C. 2000 to A.D. 2000. By AUGUSTUS DE MORGAN, Professor of Mathematics in University College, London. Demy 8vo, oblong, 5s. cloth.
- "This is quite a novelty in chronological literature. It is an *universal almanac*—universal, that is, as respects time, past, present, and future. The main object of it is, as the compiler states, to supply the place of an old almanac, which is never at hand when wanted; of the older almanac, which never was at hand; and of the universal almanac in every shape! A more useful chronological handbook could scarcely be conceived. It will save an immensity of calculation, and is in many other respects invaluable as a chronological guide and instructor."—*Oxford Herald*.

## WORKS PUBLISHED BY

**Four Lectures on the Contrasts of Ancient and Modern HISTORY.** By F. W. NEWMAN, Professor of Latin in University College, London. Foolscap 8vo, 3s. cloth.

**A Numismatic Manual;** or, Guide to the Collection and Study of Greek, Roman, and English Coins. Illustrated by Engravings of many hundred types, by means of which even imperfect and obliterated pieces may be easily deciphered. By J. Y. ARERMAN, F.S.A. 8vo, 21s. cloth.

---

## POETRY.

---

**DISCOVERY.** A POEM. By EDWARD ALDAM LEATHAM, M.A. Foolscap 8vo, 2s. 6d. cloth.

"His execution is finished and of a good school."—*Spectator*.

"Mr. Leatham's style is vigorous, his lines are musical, and his versification is correct. \* \* \* His peroration is truly eloquent."—*Britannia*.

**Love in the Moon;** A POEM. With Remarks on that Luminary. By PATRICK SCOTT, Author of "Lelio." Foolscap 4to, 5s. 6d. cloth gilt.

**Poetical Works of John Keats.** Royal 8vo, sewed, 2s.

**A Collection of Poetry for the Practice of Elocution.** Made for the use of the Ladies' College, Bedford Square. By Professor F. W. NEWMAN. Foolscap 8vo, 2s. 6d.

**The Georgics of Virgil.** Translated into Verse by the Rev. W. H. BATHURST, M.A., Rector of Barwick-in-Elmet. Foolscap 8vo, 4s. 6d. cloth.

---

## MISCELLANEOUS.

---

**GUESSES at Truth.** By TWO BROTHERS. Cheaper Edition. 2 vols. Foolscap 8vo. 10s., cloth-lettered.

**Business as it is and as it might be.** By JOSEPH LYNDELL. Crown 8vo, 1s. sewed, 1s. 6d. cloth.

\* \* \* This Work obtained the Prize of Fifty Guineas offered by the Young Men's Christian Association for the best Essay on "The Evils of the Present System of Business, and the Difficulties they Present to the Attainment and Development of Personal Piety, with Suggestions for their Removal."

**Christian Philosophy;** or, an Attempt to Display the Evidence and Excellence of Revealed Religion by its Internal Testimony. By VICESIMUS KNOX, D.D., late Fellow of St. John's College, Oxford; and Master of Tunbridge School. Foolscap 8vo, 2s. 6d., cloth.

**Suggestions on Female Education.** Two Introductory Lectures on English Literature and Moral Philosophy, delivered in the Ladies' College, Bedford Square, London. By A. J. SCOTT, A.M., Principal of Owen's College, Manchester, late Professor of the English Language and Literature in University College, London. Foolscap 8vo, 1s. 6d.

**Mr. Frere's Works on Prophecy.**

BRIEF INTERPRETATION OF THE APOCALYPSE. 8vo, 3s. 6d. cloth.

GENERAL STRUCTURE OF THE APOCALYPSE, chiefly relating to the Individual Antichrist of the Last Days. 8vo, 2s.

THREE LETTERS ON THE PROPHECIES. 8vo, 2s.

EIGHT LETTERS ON THE PROPHECIES; viz. on the Seventh Vial; the Civil and Ecclesiastical Periods; and on the Type of Jericho. 8vo, 2s. 6d.

GREAT CONTINENTAL REVOLUTION, marking the expiration of the "Times of the Gentiles." 8vo, 2s. 6d.

WALTON AND MABERLY.

## STEAM NAVIGATION AND RAILWAYS.

**THE Steam Engine, Steam Navigation, Roads, and Railways,**  
EXPLAINED AND ILLUSTRATED. A New and Cheaper Edition, revised  
and completed to the present time. By DIONYSIUS LARDNER, D.C.E., formerly  
Professor of Natural Philosophy and Astronomy in University College, London.  
One Vol. 12mo, Illustrated with Wood Engravings, 8s. 6d. cloth.

## NATURAL PHILOSOPHY AND ASTRONOMY.

**THE Electric Telegraph Popularised.** With 100 Illustrations. By  
DIONYSIUS LARDNER, D.C.E. From the "Museum of Science and Art." 12mo,  
2s. cloth.  
"The reader will find the most complete and intelligible description of  
Telegraphic Apparatus in Dr. Lardner's admirable chapters on the subject."—  
*North British Review.*

**Familiar Letters on the Physics of the Earth.** By H. BUFF,  
Professor of Physics in the University of Giessen. Edited by Dr. A. W.  
HOFMANN, Professor in the Royal College of Chemistry, London. Fcap. 8vo, 5s.  
Introduction.—Gravity and its Effects.—Tides.—Heat within the Earth.—  
Warm Springs.—Hot Springs and Jets of Steam.—Jets of Gas and Mud Volcanoes.—  
Volcanoes and Earthquakes.—Temperature of the Outermost Crust of the  
Earth.—Temperature of the Lowest Layer of the Atmosphere.—Lines of equal  
Heat.—Temperature of the Upper Layers of the Atmosphere.—The Snow Limits.  
—Glaciers.—Temperature of the Waters, and their Influence on Climate.—Cur-  
rents of the Sea.—Winds.—Moisture of the Air and Atmospheric Precipitation.  
—Electricity of the Air, Lightning, and Thunder.

**An Elementary Treatise on Mechanics,** for the Use of Junior Univer-  
sity Students. By RICHARD POTTER, A.M., Professor of Natural Philosophy in  
University College, London. Third Edition, 8vo, with numerous Diagrams,  
8s. 6d. cloth.

**An Elementary Treatise on Optics, PART I.** By RICHARD POTTER,  
A.M. Second Edition, 8vo, corrected, with numerous Diagrams, 9s. 6d. cloth.

**An Elementary Treatise on Optics, PART II.,** Containing the Higher  
Propositions. By RICHARD POTTER, A.M. 8vo, with numerous Diagrams, 12s. 6d.

**Twelve Planispheres,** forming a Guide to the Stars for every Night in the  
Year, with an Introduction. 8vo, 6s. 6d. cloth.

**Ecliptical Charts, Hours, 1, 2, 3, 4, 5, 7, 9, 10, 11, 13, 14, 19,**  
and 20, taken at the Observatory, Regent's Park, under the direction of GEORGE  
BISHOP, Esq., F.R.S., &c. 2s. 6d. each.

**Astronomical Observations,** taken at the Observatory, Regent's Park,  
during the Years 1839—1851, under the direction of GEORGE BISHOP, Esq.,  
F.R.S., &c. 4to, 12s. 6d.

**Mr. Bishop's Synoptical Table of the Elements of the Minor**  
Planets, between Mars and Jupiter, as known at the beginning of 1855, with  
the particulars relating to their discovery, &c. Arranged at the Observatory,  
Regent's Park. On a Card.

# DR. LARDNER'S MUSEUM OF SCIENCE AND ART.

A Miscellany of

INSTRUCTIVE AND AMUSING FRAGMENTS ON THE PHYSICAL SCIENCES, AND  
ON THEIR APPLICATION TO THE USES OF LIFE.

ILLUSTRATED BY ENGRAVINGS ON WOOD.

DOUBLE VOLUMES.

*Volumes 1 to 6 may now be had, strongly bound, 2 Volumes in 1 with Indexes, cloth lettered, price 3s. 6d. each double volume.*

“ ‘Dr. Lardner’s Museum,’ one of the few works of the kind which can be recommended as at once popular and accurate.”—*Sir David Brewster.*

Contents of Vols. I. and II. (double), 3s. 6d. cloth.

**VOL. I.,** price 1s. 6d., in handsome boards.

PART I., price 5d.

1. The Planets; Are they Inhabited Globes?
2. Weather Prognostics.
3. The Planets. Chap. II.
4. Popular Fallacies in Questions of Physical Science.

PART II., price 5d.

5. Latitudes and Longitudes.
6. The Planets. Chap. III.
7. Lunar Influences.
8. Meteoric Stones and Shooting Stars. Chap. I.

PART III., price 6d.

9. Railway Accidents. Chap. I.
10. The Planets. Chap. IV.
11. Meteoric Stones and Shooting Stars. Chap. II.
12. Railway Accidents. Chap. II.
13. Light.

**VOL. II.,** price 1s. 6d., in handsome boards.

PART IV., price 5d.

14. Common Things.—Air.
15. Locomotion in the United States. Chap. I.
16. Cometary Influences. Chap. I.
17. Locomotion in the United States. Chap. II.

PART V., price 5d.

18. Common Things.—Water.
19. The Potter’s Art. Chap. I.
20. Locomotion in the United States. Chap. III.
21. The Potter’s Art. Chap. II.

PART VI., price 6d.

22. Common Things.—Fire.
23. The Potter’s Art. Chap. III.
24. Cometary Influences. Chap. II.
25. The Potter’s Art. Chap. IV.
26. The Potter’s Art. Chap. V.

Contents of Vols. III. and IV. (double), 3s. 6d. cloth.

**VOL. III.,** price 1s. 6d., in handsome boards.

PART VII., price 5d.

27. Locomotion and Transport, their Influence and Progress. Chap. I.
28. The Moon.
29. Common Things.—The Earth.
30. Locomotion and Transport, their Influence and Progress. Chap. II.

PART VIII., price 5d.

31. The Electric Telegraph. Chap. I.

32. Terrestrial Heat. Chap. I.
33. The Electric Telegraph. Chap. II.
34. The Sun.

PART IX., price 6d.

35. The Electric Telegraph. Chap. III.
36. Terrestrial Heat. Chap. II.
37. The Electric Telegraph. Chap. IV.
38. The Electric Telegraph. Chap. V.
39. The Electric Telegraph. Chap. VI.

**VOL. IV.,** price 1s. 6d., in handsome boards.

PART X., price 5d.

40. Earthquakes and Volcanoes. Chap. I.
41. The Electric Telegraph. Chap. VII.
42. The Electric Telegraph. Chap. VIII.
43. The Electric Telegraph. Chap. IX.

PART XI., price 5d.

44. Barometer, Safety Lamp, and Whitworth’s Micrometric Apparatus.

45. The Electric Telegraph. Chap. X.
46. Earthquakes and Volcanoes. Chap. II.
47. The Electric Telegraph. Chap. XI.

PART XII., price 6d.

48. Steam.
49. The Electric Telegraph. Chap. XII.
50. The Electric Telegraph. Chap. XIII.
51. The Electric Telegraph. Chap. XIV.
52. The Electric Telegraph. Chap. XV.

**DR. LARDNER'S MUSEUM** (*Continued*) :—

Contents of Vols. V. and VI. (double), 3s. 6d. cloth.

VOL. V., price 1s. 6d., contains—

PART XIII., price 5d.

53. The Steam Engine. Chap. I.  
 54. The Eye. Chap. I.  
 55. The Atmosphere.  
 56. Time. Chap. I.

Part XIV., price 5d.

57. The Steam Engine. Chap. II.  
 58. Common Things. Time. Chap. II.

59. The Eye. Chap. II.  
 60. Common Things. Pumps.

Part XV., price 6d.

61. The Steam Engine. Chap. III.  
 62. Common Things. Time. Chap. III.  
 63. The Eye. Chap. III.  
 64. Common Things. Time. Chap. IV.  
 65. Common Things. Spectacles—The Kaleidoscope.

VOL. VI., price 1s. 6d., contains—

PART XVI., price 5d.

66. Clocks and Watches, Chap. I.  
 67. Microscopic Drawing and Engraving. Chap. I.  
 68. Locomotive. Chap. I.  
 69. Microscopic Drawing and Engraving. Chap. II.

PART XVII., price 5d.

70. Clocks and Watches. Chap. II.  
 71. Microscopic Drawing and Engraving. Chap. III.

72. Locomotive. Chap. II.  
 73. Microscopic Drawing and Engraving. Chap. IV.

PART XVIII., price 6d.

74. Clocks and Watches. Chap. III.  
 75. Thermometer.  
 76. New Planets.—Leverrier and Adams' Planet.  
 77. Leverrier and Adams' Planet, concluded.  
 78. Magnitude and Minuteness.

\* \* *Continued in Weekly Numbers at 1d.; Monthly Parts at 5d.; Quarterly Volumes at 1s. 6d., and Half Yearly Volumes at 3s. 6d.*

**First Book of Natural Philosophy;** or, an Introduction to the Study of Statics, Dynamics, Hydrostatics, and Optics, with numerous examples. By SAMUEL NEWTH, M.A., Fellow of University College, London. 12mo, 3s. 6d.

**Elements of Mechanics and Hydrostatics.** By SAMUEL NEWTH, M.A. Second Edition, small 8vo, 7s. 6d. cloth.

**Dr. Lardner's Handbook of Astronomy.** From the "Handbook of Natural Philosophy." 37 Plates and 200 Woodcuts. Large 12mo, 16s. 6d. cloth.

**Handbook of Natural Philosophy and Astronomy.** By DIONYSIUS LARDNER, formerly Professor of Natural Philosophy and Astronomy in University College, London. Three Vols., large 12mo, with very numerous Illustrations on Wood.

**FIRST COURSE,** One Vol., 12s. 6d. cloth, contains :—Mechanics; Hydrostatics; Hydraulics; Pneumatics; Sound; Optics. •

**SECOND COURSE,** One Vol., 8s. 6d., contains :—Heat; Common Electricity; Magnetism; Voltaic Electricity.

**THIRD COURSE,** One Vol., 16s. 6d., contains :—Astronomy and Meteorology. With 37 Plates and 200 Woodcuts.

\* \* *Any volume may be purchased separately.* •

**MATHEMATICS, &c.**

**ELEMENTS of Arithmetic.** By AUGUSTUS DE MORGAN, Professor of Mathematics in University College, London. Fifth Edition, with Eleven Appendixes, Royal 12mo, 5s. cloth.

**De Morgan's Trigonometry and Double Algebra.** Royal 12mo, 7s. 6d. cloth.

**Barlow's Tables of Squares, Cubes, Square Roots, Cube Roots, AND RECIPROCAIS**, up to 10,000. Stereotype Edition, examined and corrected. Under the superintendence of the Society for the Diffusion of Useful Knowledge. Royal 12mo, cloth, 8s.

**Arithmetical Books and Authors.** From the Invention of Printing to the present time; being Brief Notices of a large Number of Works drawn up from actual inspection. By AUGUSTUS DE MORGAN, Professor of Mathematics in University College, London. Cheap issue. Royal 12mo, 2s. 6d. cloth.

"A great number of persons are employed in teaching Arithmetic in the United Kingdom. In publishing this work, I have the hope of placing before many of them more materials for the prevention of inaccurate knowledge of the literature of their science than they have hitherto been able to command, without both expense and research."—*Preface*.

**A Course of Arithmetic as Taught in the Pestalozzian School, WORKSOP.** By J. L. ELLENBERGER. 12mo, 5s. cloth.

**The First Book of Euclid Explained to Beginners.** By C. P. MASON, B.A., Fellow of University College, and Principal of Denmark Hill Grammar School. Fcap. 8vo, 1s. 9d. cloth.

**Reiner's Lessons on Form; or, an Introduction to Geometry**, as given in a Pestalozzian School, Cheam, Surrey. 12mo, with numerous Diagrams, 3s. 6d. cloth.

**A First Book on Plane Trigonometry.** Geometrical Trigonometry, and its applications to Surveying, with numerous Examples. For the use of Schools. By G. W. HEMMING, M.A., Fellow of St. John's College, Cambridge, and Author of a Treatise on the "Differential and Integral Calculus." With Diagrams, 12mo, cloth limp, 1s. 6d.

**Ritchie's Principles of Geometry**, familiarly Illustrated, and applied to a variety of useful purposes. Designed for the Instruction of Young Persons. Second Edition, revised and enlarged, 12mo, with 150 Woodcuts, cloth limp, 1s. 6d.

**Tables of Logarithms, Common and Trigonometrical, to Five PLACES.** Under the Superintendence of the Society for the Diffusion of Useful Knowledge. Fcap. 8vo, cloth limp, 1s. 6d.

**Lessons on Number**, as given at the Pestalozzian School, Cheam, Surrey. By CHARLES REINER. The Master's Manual. New Edition. 12mo, cloth, 5s. The Scholar's Praxis. 12mo, 2s. bound.

## GREEK.

**THE Anabasis of Xenophon.** Expressly for Schools. With Notes, a Geographical and Biographical Index, and a Map. By J. T. V. HARDY, B.A., Principal of Huddersfield College; and ERNEST ADAMS, Classical Master in University College School. 12mo, 4s. 6d. cloth.

**Lexicon to Æschylus.** Containing a Critical Explanation of the more Difficult Passages in the Seven Tragedies. By the Rev. W. LINWOOD, A.M., M.R.A.S. Second Edition. Revised. 8vo, 12s. cloth.

**New Greek Delectus; Being Sentences for Translation from Greek into English, and English into Greek; arranged in a Systematic Progression.** By Dr. RAPHAEL KUHNER. Translated and Edited from the German, by Dr. ALEXANDER ALLEN. Third Edition, revised. 12mo, 4s. cloth.

**Four Gospels in Greek.** For the use of Schools. Fcap. 8vo, cloth limp, 1s. 6d. This part of the Greek Testament is printed separately for the use of Students beginning to learn Greek, the Evangelists being more generally read than the rest of the Testament.

**London Greek Grammar.** Designed to exhibit, in small compass, the Elements of the Greek Language. Edited by a GRADUATE of the University of Oxford. Fifth Edition. 12mo, cloth limp, 1s. 6d.

**Greek Testament.** GRIESBACH'S TEXT, with the various readings of MILL and SCHOLZ. Second Edition, revised. Fcap. 8vo, cloth, 6s. 6d.; morocco, 12s. 6d.

**Plato.** The Apology of SOCRATES, CRITO, and part of the PHAEDO, with English Notes, a Life of Socrates, &c. Edited by Dr. W. SMITH. Second Edition. 12mo, cloth, 5s.

**Robson's Constructive Greek Exercises.** 12mo, cloth, 7s. 6d.

\*.\* This Work, which was originally intended to be a new edition of "Allen's Constructive Greek Exercises," will take the place of that book. The general principles of both are identical.

**Introduction to the Art of Composing Greek Iambics,** in Imitation of the Greek Tragedians. Designed for the use of Schools. By the Rev. CHARLES TAYLER. 12mo, 2s. 6d.

**What is the Power of the Greek Article;** and how may it be expressed in the English Version of the New Testament? By JOHN TAYLOR. 8vo, 2s. 6d.

---

## LATIN.

---

**NEW Latin Delectus;** being Sentences for Translation from Latin into English, and English into Latin; arranged in a Systematic Progression, on the plan of the Greek Delectus. By Dr. ALEXANDER ALLEN. Third Edition, 12mo, 4s. cloth.

**New Latin Reading-Book;** Short Sentences, Easy Narrations, and Descriptions, from Caesar's Gallic War, arranged in Systematic Progression. With a Dictionary. Second Edition, revised. 12mo, 2s. 6d. cloth.

**Constructive Latin Exercises,** for teaching the Elements of the Language on a System of Analysis and Synthesis; with Latin Reading Lessons, and copious Vocabularies. By JOHN ROBSON, B.A., late Assistant Master in University College School. Third Edition, thoroughly revised. 12mo, 4s. 6d. cloth.

**London Latin Grammar;** including the Eton Syntax and Prosody in English, accompanied with Notes. Edited by a GRADUATE of the University of Oxford. Fifteenth Edition. 12mo, 1s. 6d. cloth limp.

**First Latin Reading Lessons;** with complete Vocabularies. Intended as an Introduction to Caesar. By JOHN ROBSON, B.A., Assistant Master in University College School. 12mo, 2s. 6d. cloth.

**The Principal Roots of the Latin Language,** simplified by a display of their Incorporation into the English Tongue; with copious Notes. By HENRY HALL. Fifth Edition. 12mo, 1s. 6d. cloth limp.

**The Germania of Tacitus.** With Ethnological Dissertations and Notes. By Dr. R. G. LATHAM. Author of the "English Language," &c. With a Map. Demy 8vo, 12s. 6d.

**Tacitus, Germania, Agricola,** and First Book of the Annals. With English Notes and BOTTFIGER'S Remarks on the style of TACITUS. Third Edition revised and much improved. Edited by Dr. W. SMITH. 12mo, 5s. cloth.

**Caesar for Beginners.** Latin and English; with the Original Text at the end. 12mo, 3s. 6d. cloth.

- Mythology for Versification**; or, a Brief Sketch of the Fables of the Ancients, prepared to be rendered into Latin verse. By the late Rev. F. HODGSON, M.A. (Provost of Eton). New Edition. 12mo, 3s. bound. KEY to Ditto. 8vo, 7s.
- Select Portions of Sacred History**, conveyed in sense for Latin Verses. By the late Rev. F. HODGSON, M.A. (Provost of Eton). Third Edition. 12mo, 3s. 6d. cloth. KEY to Ditto. Royal 8vo, 10s. 6d. cloth.
- Sacred Lyrics**; or, Extracts from the Prophetical and other Scriptures of the Old Testament; adapted to Latin Versification in the principal Metres of HORACE. By the late Rev. F. HODGSON, M.A. (Provost of Eton). 12mo, 6s. 6d. cloth. KEY to Ditto. 8vo, 12s. cloth.
- Latin Authors.** Selected for the use of Schools; containing portions of Phædrus, Ovid's Metamorphoses, Virgil's Æneid, Casar and Tacitus. 12mo, 1s. 6d. cloth.

---



---

## HEBREW.

---

- GRAMMAR of the Hebrew Language.** By HYMAN HURWITZ, late Professor of Hebrew in University College, London. Fourth Edition, revised and enlarged. 8vo, 13s. cloth. Or in Two Parts, sold separately:—ELEMENTS, 4s. 6d. cloth; ETYMOLOGY and SYNTAX, 9s. cloth.
- Book of Genesis in English Hebrew**; accompanied by an Interlinear Translation, substantially the same as the authorised English version; Philological Notes, and a Grammatical Introduction. By W. GREENFIELD, M.R.A.S. Fourth Edition. Cheap Issue. 8vo, 4s. 6d. cloth. With the original Text in Hebrew characters at the end. 8vo, 6s. 6d. cloth.

---



---

## MAPS.

---

- TEACHING Maps**:—I. RIVERS AND MOUNTAINS, of England, Wales, and Part of Scotland. 6d. II.—TOWNS of Ditto. 6d.
- Projections.** Three Maps. MERCATOR. EUROPE. BRITISH ISLES. Stitched in a Cover, 1s. Single Maps, 4d. each.
- Projections**; with Outline of Country. Three Maps stitched in a Cover, 1s. Single Maps, 4d. each.

---



---

## ENGLISH.

---

- THE English Language.** By Dr. R. G. LATHAM, F.R.S., late Fellow of King's College, Cambridge. Fourth Edition, greatly enlarged. 2 Vols. 8vo. 11. 8s.
- An English Grammar for the Use of Schools.** By Dr. R. G. LATHAM, F.R.S., late Fellow of King's College, Cambridge. Sixth Edition. 12mo, 4s. 6d. cloth.
- Elements of English Grammar, for the Use of Ladies' Schools.** By Dr. R. G. LATHAM, F.R.S. Fcap. 8vo, 1s. 6d. cloth.
- Elements of English Grammar, for Commercial Schools.** By Dr. R. G. LATHAM, F.R.S. Fcap. 8vo, 1s. 6d. cloth.



**A Handbook of the English Language.** By Dr. R. G. LATHAM, F.R.S.  
Second Edition, revised and much improved. Crown 8vo, 7s. 6d. cloth.

The object of the "Handbook" is to present to students for examination, in a more condensed form, the chief facts and reasonings of "The English Language." Less elaborate than that work, it is less elementary than the "English Grammar." Like all the other works by the same author, it gives great prominence to the etymological relations of our tongue; and insists upon historical investigation, and the application of the general principles of comparative philology, as the true means of exhibiting its real growth and structure, in opposition to the more usual method of treating it as a mass of irregularities. It has the further object of supplying a knowledge of those laws of speech and principles of grammar which apply to language generally.

**History and Etymology of English Grammar, for the Use of CLASSICAL SCHOOLS.** By Dr. R. G. LATHAM, F.R.S. Fcap. 8vo, 1s. 6d. cloth.

**First Outlines of Logic,** applied to Grammar and Etymology. By Dr. R. G. LATHAM. 12mo, 1s. 6d. cloth.

**New English Spelling Book.** By the Rev. GORHAM D. ABBOTT. Second Edition, with Reading Lessons. 12mo, sewed, 6d.

**First English Reader.** By the Rev. G. D. ABBOTT. 12mo, with Illustrations. 1s. cloth limp.

**Second English Reader.** By the Rev. G. D. ABBOTT. 12mo, 1s. 6d. cloth limp.

## FRENCH.

**MERLET'S French Grammar.** By P. F. MERLET, Professor of French in University College, London. New Edition. 12mo, 5s. 6d. bound. Or, sold in two Parts: PRONUNCIATION and ACCIDENCE, 3s. 6d.; SYNTAX, 3s. 6d. (KEY, New Edition, 3s. 6d.)

**Merlet's Traducteur; Or, HISTORICAL, DRAMATIC, and MISCELLANEOUS SELECTIONS** from the best FRENCH WRITERS; accompanied by Explanatory Notes; a selection of Idioms, &c. New Edition. 12mo, 5s. 6d. bound.

**Merlet's Dictionary of the Difficulties of the French Language;** containing Explanations of every Grammatical Difficulty; Synonymes explained in a concise manner; Versification; Etymological Vocabulary; Free Exercises, with Notes; Mercantile Expressions, Phrases, and Letters; Elements of French Composition. A new and enlarged Edition. 12mo, 6s. 6d. bound.

**Merlet's French Synonymes;** explained in Alphabetical Order, with Copious Examples. (From the "DICTIONARY OF DIFFICULTIES.") 12mo, 2s. 6d. cloth.

**Stories from French Writers.** Interlinear (from Merlet's "Traducteur.") 12mo, 2s.

## GERMAN.

**The Adventures of Ulysses; a German Reading Book;** with a short Grammar and a Vocabulary. By PAUL HIRSCH. Twenty-four Woodcuts. 12mo, 6s. cloth.

*Separately,*

**A Short Grammar of the German Language.** 12mo, cloth, 2s.

## ITALIAN.

**First Italian Course;** Being a Practical and Easy Method of Learning the Elements of the Italian Language. By W. BROWNING SMITH, M.A., Second Classical Master of the City of London School. Royal 18mo, cloth, 3s. 6d.

**Panizzi's Italian Grammar.** 12mo, cloth limp, 1s. 6d.

## INTERLINEAR TRANSLATIONS.

*Cheap Issue, at 1s. 6d. per volume.*

**LOCKE'S System of Classical Instruction**, restoring the Method of Teaching formerly practised in all Public Schools. The Series consists of the following Interlinear Translations with the Original Text, in which the quantity of the doubtful Vowels is denoted; critical and explanatory Notes, &c.

\*\* By means of these Works, that excellent system of Tuition is effectually restored which was established by Dean Colet, Erasmus, and Lily, at the foundation of St. Paul's School, and was then enjoined by authority of the State, to be adopted in all other Public Seminaries of learning throughout the kingdom. Each Volume, 1s. 6d.

### LATIN.

1. **PLÆDIUS'S FABLES OF ÆSOP.**
2. **OVID'S METAMORPHOSES. BOOK I.**
3. **VIRGIL'S ÆNEID. Book I.**
4. **PARSING LESSONS TO VIRGIL.**
5. **CÆSAR'S INVASION OF BRITAIN.**

### GREEK.

1. **LUCIAN'S DIALOGUES. Selections.**
2. **THE ODES OF ANACREON.**
3. **HOMER'S ILLAD. Book I.**
4. **PARSING LESSONS TO HOMER.**
5. **XENOPHON'S MEMORABILIA. Part I.**
6. **HERODOTUS'S HISTORIES. Selections.**

**FRENCH.**—**SISMONDI**; the **BATTLES OF CHESSEY and POICTIERS.**

**GERMAN.**—**STORIES FROM GERMAN WRITERS.**

\*\* A Second Edition of the Essay, explanatory of the System, with an Outline of the Method of Study, is published. 12mo, sewed, price 6d.

## ANIMAL MAGNETISM.

**BARON Von Reichenbach's Researches on Magnetism, Electricity, Heat, Light, Crystallisation, and Chemical Attraction, in their Relation to the Vital Force.** Translated and Edited (at the express desire of the Author) by **DR. GREGORY**, of the University of Edinburgh. Cheap Issue. One Volume, 8vo, 6s. 6d. cloth.

"The merits of this remarkable volume are great. The painstaking, conscientious, cautious, ingenious,—we had almost said the religious, and certainly the self-possessed enthusiasm with which the experimental clue is followed from turn to turn of the labyrinth, is surpassed by nothing of the same sort in the whole range of contemporary science."—*North British Review.*

## ANATOMY, MEDICINE, &c.

**DR. Quain's Anatomy.** Edited by **DR. SHARPEY** and **MR. QUAIN**, Professors of Anatomy and Physiology in University College, London. Fifth Edition. Complete in Two Volumes, 8vo. Illustrated by four hundred Engravings on Wood. Price 2l.

**Demonstrations of Anatomy.** A Guide to the Dissection of the Human Body. By **GEORGE VINER ELLIS**, Professor of Anatomy in University College, London. Third Edition. Small 8vo. 12s. 6d. cloth.

**The Essentials of Materia Medica, Therapeutics, and the Pharmacopœias.** For the use of Students and Practitioners. By **ALFRED BARING GARROD, M.D.**, Professor of Materia Medica and Therapeutics in University College, London. Fcp. 8vo. 6s. 6d.

**Lectures on the Principles and Practice of Midwifery.** By **EDWARD WM. MURPHY, A.M., M.D.**, Professor of Midwifery in University College, London. One Volume, 8vo, many Illustrations, 16s.

"The work will take rank among the best treatises on the obstetric art. By this work, Dr. Murphy has placed his reputation and his fame on a solid and durable foundation."—*Dublin Medical Press.*

**A Handbook of Physiology.** By WILLIAM SENHOUSE KIRKES, M.D., Demonstrator of Morbid Anatomy at St. Bartholomew's Hospital. Assisted by JAMES PAGET, Lecturer on General Anatomy and Physiology at St. Bartholomew's Hospital. Second Edition. One Volume 12mo, with Illustrations. 12s. 6d.

**On Pain After Food; its Causes and Treatment.** By EDWARD BALLARD, M.D., Lond., Lecturer on the Practice of Medicine at the School of Medicine adjoining St. George's Hospital. One vol. 4s. 6d. cloth.

**Physical Diagnosis of the Diseases of the Abdomen.** By EDWARD BALLARD, M.D., Late Medical Tutor in University College, London. Large 12mo, 7s. 6d. cloth.

"The profession is much indebted to Dr. Ballard for this unpretending little volume, which, we feel certain, if carefully studied, will accomplish its object of removing many of the difficulties at present surrounding the diagnosis of abdominal diseases."—*Lancet*.

**A Practical Treatise on Diseases of the Heart and Lungs, their Symptoms and Treatment, and the Principles of Physical Diagnosis.** By W. H. WALSH, M.D., Professor of the Principles and Practice of Medicine and Clinical Medicine in University College, London; Physician to University College Hospital, and Consulting Physician to the Hospital for Consumption and Diseases of the Chest. A new and considerably enlarged edition. One Volume, 12s. 6d. cloth.

"This work is what its name indicates it to be—eminently practical. That it will add largely to the already great reputation of its author, no question can be entertained. It is far in advance of any other Treatise on Diseases of the Chest, either in this or any other country. Every page—we were about to say every line—contains a fact, often new, and *always resting on the Author's own observations*. Cases are quoted to prove every new statement, and to support every argument adduced in opposition to others. To the practitioner, the clinical teacher, and to the student, this work will prove alike invaluable."—*Medical Times*.

**The Nature and Treatment of Cancer.** By W. H. WALSH, M.D., Professor of Medicine in University College, Physician to University College Hospital, and Consulting Physician to the Hospital for Consumption and Diseases of the Chest. One Volume, 8vo, with Illustrations. Cheap Issue, 6s. 6d.

**The Diseases of the Rectum.** By RICHARD QUAIN, F.R.S., Professor of Clinical Surgery in University College, and Surgeon to University College Hospital. With Lithographic Plates. Post 8vo. 7s. 6d. cloth.

"This Treatise is eminently of a practical character, and contains much original and valuable matter. It is not indeed a literary compilation, but rather an exposition of the author's opinions and practice in those diseases."—*Association Journal*.

**The Science and Art of Surgery.** Being a Treatise on Surgical Injuries, Diseases, and Operations. By JOHN ERICHSEN, Professor of Surgery in University College, and Surgeon to University College Hospital. 250 Wood Engravings. 8vo. 1l. 5s.

"The aim of Mr. Erichsen appears to be, to improve upon the plan of Samuel Cooper; and by connecting in one volume the science and art of Surgery, to supply the student with a text-book and the practitioner with a work of reference, in which scientific principles and practical details are alike included.

"It must raise the character of the author, and reflect great credit upon the College in which he is Professor, and we can cordially recommend it as a work of reference, both to students and practitioners."—*Medical Times*.

**The Microscopic Anatomy of the Human Body in Health AND DISEASE.** Illustrated with numerous Drawings in Colour. By ARTHUR HILL HASSALL, M.B., Fellow of the Linnean Society, Member of the Royal College of Surgeons, &c. &c. Two Vols. 8vo, 2l. 5s.

**Hassall's History of the British Freshwater Algae, including Descriptions of the Desmidiæ and Diatomaceæ.** With upwards of 100 Plates, illustrating the various species. Two Vols. 8vo, 2l. 5s.

**Morton's Surgical Anatomy of the Principal Regions.**

Completed by Mr. CANOE, late Assistant Surgeon, University College Hospital. Twenty-five Lithographic Illustrations Coloured, and Twenty-five Woodcuts. Royal 8vo, 21s. cloth lettered.

"The work thus completed constitutes a useful guide to the student, and remembrancer to the practitioner. We can speak very favourably of the general execution of the work. The coloured lithographs are, for the most part, well drawn, and faithfully represent the broad features of the several parts. The woodcuts are well engraved, and very clearly exhibit the points which they are intended to illustrate."—*Medical Gazette*.

**A Series of Anatomical Plates in Lithography.** Edited by JONES QUAIN, M.D., and ERASMUS WILSON, F.R.S.

\*\*\* A remarkably cheap issue is now in course of delivery to Subscribers at the following low prices:—

	To Subscribers.	Former Price.
THE COMPLETE WORK, in Two Volumes, Royal	£ s. d.	£ s. d.
Folio, Half-bound Morocco . . . . .	5 5 0	8 8 0
THE SAME, Full Coloured, Half-bound Morocco . . . . .	8 8 0	14 0 0

The Work may also be subscribed for in separate portions, bound in Cloth and Lettered, as follows:—

	PLAIN.		COLOURED.	
	To Subscribers.	Former Price.	To Subscribers.	Former Price.
	£ s. d.	£ s. d.	£ s. d.	£ s. d.
Muscles. 51 Plates . . . . .	1 5 0	1 18 0	— 2 4 0	3 12 0
Vessels. 50 Plates . . . . .	1 5 0	1 18 0	— 2 0 0	3 3 0
Nerves. 38 Plates . . . . .	1 1 0	1 10 0	— 1 14 0	2 16 0
Viscera. 32 Plates . . . . .	0 17 0	1 5 0	— 1 10 0	2 8 0
Bones and Ligaments. 30 Plates . . . . .	0 17 0	1 5 0	— 1 0 0	1 11 6

\*\*\* Proposals with full particulars may be had of the Publishers, by whom and by all Booksellers, Subscribers' names will be received.

**On Gravel, Calculus, and Gout;** chiefly an Application of Professor Liebig's Physiology to the Prevention and Cure of those Diseases. By H. BENCE JONES, M.D., F.R.S., Physician to St. George's Hospital. 8vo, 6s. cloth.**CHEMISTRY, &c.****PRINCIPLES of Agricultural Chemistry,** with Special Reference to the late Researches made in England. By JUSTUS VON LIEBIG, Professor of Chemistry in the University of Munich. Small 8vo., 3s. 6d. cloth. *Just published.***Familiar Letters on Chemistry.** In its relations to Physiology, Dietetics, Agriculture, Commerce, and Political Economy. By JUSTUS VON LIEBIG. A New and Cheap Edition, revised throughout, with many additional Letters. Complete in one Volume, Foolscap 8vo, price 6s. cloth.**Practical Pharmacy.** The Arrangements, Apparatus, and Manipulations of the Pharmaceutical Shop and Laboratory. By FRANCIS MOHR, Ph. D., and THEOPHILUS REDWOOD, Professor of Chemistry and Pharmacy to the Pharmaceutical Society. 400 Engravings on Wood. 8vo, 6s. 6d. cloth.**Gregory's Handbook of Inorganic Chemistry.** For the use of Students. By WILLIAM GREGORY, M.D., Professor of Chemistry in the University of Edinburgh. Third Edition, revised and enlarged. 12mo, 5s. 6d. "A young man who has mastered these few and by no means closely printed pages, may venture to face any board of examiners on Chemistry, without fear of being posed by any fair question."—*Association Journal*.**Gregory's Handbook of Organic Chemistry;** being a New and greatly Enlarged Edition of the "Outlines of Organic Chemistry, for the Use of Students." One volume, large 12mo, 9s. 6d. cloth.

**Handbook of Organic Analysis.** By JUSTUS LIEBIG. Edited by DR. HOFMANN, Professor in the Royal College of Chemistry, London. Large 12mo. Illustrated by 85 Wood Engravings. 5s. cloth.

"The work now before us is a most valuable contribution to our knowledge on this most important subject. The style is lucid, and the processes are not only explained to the mind, but are made manifest to the eye by a profusion of beautiful illustrations."—*Medical Times*.

**Handbook of Inorganic Analysis.** By FRIEDRICH WÖHLER, M.D., Professor of Chemistry in the University of Gottingen. Translated and Edited by DR. HOFMANN, Professor in the Royal College of Chemistry, London. Large 12mo, 6s. 6d. cloth.

"Next to Rose of Berlin in the ranks of living analytic chemists, particularly in the inorganic department of the art, stands Friedrich Wöhler, who has in this book given us a compendium of inorganic analysis, illustrated by examples of the methods to be pursued in the examination of minerals, both of a simple and complex constitution, which, if followed out by the student with ordinary care and patience, and with some little practical instruction, will not fail to render him a thorough master of this division of chemical knowledge."—*Association Journal*.

**Elements of Chemical Analysis, Qualitative, and Quantitative.**

By EDWARD ANDREW PARNELL, author of "Applied Chemistry; in Arts, Manufactures, and Domestic Economy." Second Edition, revised throughout, and enlarged by the addition of 200 pages. 8vo, Cheap Issue, 9s. cloth.

**Animal Chemistry; or, Chemistry in its Applications to Physiology and Pathology.** By JUSTUS LIEBIG, M.D. Edited from the Author's Manuscript, by WILLIAM GREGORY, M.D. Third Edition, almost wholly re-written. 8vo, Part I. (the first half of the work) 6s. 6d. cloth.

**Chemistry in its Application to Agriculture and Physiology.**

By JUSTUS LIEBIG, M.D. Edited from the Manuscript of the Author, by LYON PLAYFAIR, Ph. D., and WM. GREGORY, M.D. Fourth Edition, revised. Cheap Issue. 8vo, 6s. 6d.

**Dyeing and Calico Printing.** By EDWARD ANDREW PARNELL, Author of "Elements of Chemical Analysis." (Reprinted from Parnell's "Applied Chemistry in Manufactures, Arts, and Domestic Economy, 1844.") With Illustrations. 8vo, 7s. cloth.

**Outlines of the Course of Qualitative Analysis followed in the GIESSEN LABORATORY.** By HENRY WILL, Ph. D., Professor Extraordinary of Chemistry in the University of Giessen. With a Preface by BARON LIEBIG. 8vo, 6s., or with the Tables mounted on linen, 7s.

**Elements of Chemistry.** Edited by Professors LIEBIG and GREGORY. Eighth Edition. 1 Vol. 8vo, 1l. 10s.

## COMMON-PLACE BOOKS AND LITERARY DIARIES.

**THE Private Diary.** Arranged, Printed, and Ruled for receiving an account of every day's employment for the space of one year. With an Index and Appendix. Cheaper Edition. Post 8vo, strongly half-bound, 3s. 6d.

**The Student's Journal.** Formed on the plan of the "Private Diary." Cheaper Edition. Post 8vo, strongly half-bound, 3s. 6d.

**The Literary Diary;** or Complete Common-Place Book, with an Explanation and an Alphabet of Two Letters on a Leaf. Cheaper Edition. Post 4to, ruled throughout, and strongly half-bound, 8s. 6d.

**A Pocket Common-place Book.** With LOCKE'S Index. Cheaper Edition. Post 8vo, strongly half-bound 6s. 6d.

## DRAWING, &amp;c.

**LINEAL Drawing Copies for the Earliest Instruction.** Comprising 200 subjects on 24 sheets, mounted on 12 pieces of thick pasteboard. By the Author of "Drawing for Young Children." In a portfolio. 5s. 6d.

**Easy Drawing Copies for Elementary Instruction.** By the Author of "Drawing for Young Children." Set I. Twenty-six Subjects mounted on pasteboard. Price 3s. 6d., in a Portfolio. Set II. Forty-one Subjects mounted on pasteboard. Price 3s. 6d., in a Portfolio.

\*.\* The Work may also be had (two sets together) in one Portfolio, price 6s. 6d.

**Drawing Models.** Consisting of Forms for Constructing various Buildings, Gateways, Castles, Bridges, &c. The Buildings will be found sufficiently large to be drawn from by a numerous Class at the same time. In a Box, with a small Treatise on Drawing and Perspective. Price 2l. 10s. Length of the Box, 18½ inches; breadth 13 inches; height 8½ inches.

**Drawing Materials.** A Quarto Copybook of 24 leaves, common paper, 6d. A Quarto Copybook of 24 leaves, paper of superior quality. 1s. 3d. A Quarto Copybook of 60 leaves, 1s. 6d. Pencils, with very thick lead, B.F.B. 2s. per half-dozen. Pencils, with thick lead, F. at 1s. 6d. ditto. Drawing Chalk, 6d. per dozen sticks, in a Box. Port-crayons for holding the Chalk, 4d. each.

**Perspective.** Its Principles and Practice. By G. B. MOORE. In two parts, Text and Plates. 8vo, cloth, 8s. 6d.

**The Principles of Colour applied to Decorative Art.** By G. B. MOORE, Teacher of Drawing in University College, London. Fcap. 2s. 6d.

## SINGING.

**THE Singing Master.** People's Edition. (One-Half the Original Price.) Sixth Edition. 8vo. 6s. cloth lettered.

"What chiefly delights us in the 'Singing Master' is the intermixture of many little moral songs with the ordinary pieces. These are chiefly composed by Mr. Hickson himself; and we could scarcely imagine anything of the kind better executed. They relate to exactly the class of subjects which all who wish well to the industrious orders would wish to see imprinted on their inmost nature—contentment with their lowly but honourable lot, the blessings that flow from industry, the fostering of the domestic affections, and aspirations for the improvement of society."—*Chambers' Journal*.

\*.\* Sold also in Five Parts, any of which may be had separately as follows:—

**FIRST LESSONS IN SINGING AND THE NOTATION OF MUSIC.** Containing Nineteen Lessons in the Notation and Art of Reading Music. 8vo, 1s. sewed.

**RUDIMENTS OF THE SCIENCE OF HARMONY OR THOROUGH BASS.** 8vo, 1s. sewed.

**THE FIRST CLASS TUNE BOOK.** A selection of thirty single and pleasing airs, arranged with suitable words for young children. 8vo, 1s. sewed.

**THE SECOND CLASS TUNE BOOK.** A selection of Vocal Music adapted for youth of different ages, and arranged (with suitable words) as two and three-part harmonies. 8vo, 1s. 6d.

**THE HYMN TUNE BOOK.** A selection of Seventy popular Hymn and Psalm Tunes, arranged with a view of facilitating the progress of children learning to sing in parts. 8vo, 1s. 6d.

The words without the Music may be had in three small books as follows:—

MORAL SONGS, from the FIRST CLASS TUNE BOOK, 1d.

MORAL SONGS, from the SECOND CLASS TUNE BOOK, 1d.

HYMNS from the HYMN TUNE BOOK, 1½d.

\*.\* The Vocal Exercises, Moral Songs, and Hymns, with the Music, may also be had, printed on Cards, price Twopence each Card, or Twenty-five for Three Shillings.

.

!

