

LUBRICATION

ORDER

L05-4310-247-15

2 APRIL 1965

COMPRESSOR, ROTARY, DIESEL DRIVEN, AIR, TRAILER MOUNTED, 250CFM, 100PSI (ENGINE, CONTINENTAL MODEL JD403) (JOY MODEL RPV250DC20MS1)

Reference: C9100-IL

Intervals are based on normal hours of operation. Reduce to compensate for abnormal operation and severe conditions. During inactive periods sufficient lubrication must be performed for adequate preservation.

Relubricate after washing or fording.

Clean fittings before lubricating.

Clean parts with SOLVENT, dry-cleaning, or with OIL, fuel, Diesel. Dry before lubricating.

Drain crankcase when hot. Fill and check level.

A dotted circle indicates a drain below.

LUBRICANT • INTERVAL

INTERVAL • LUBRICANT

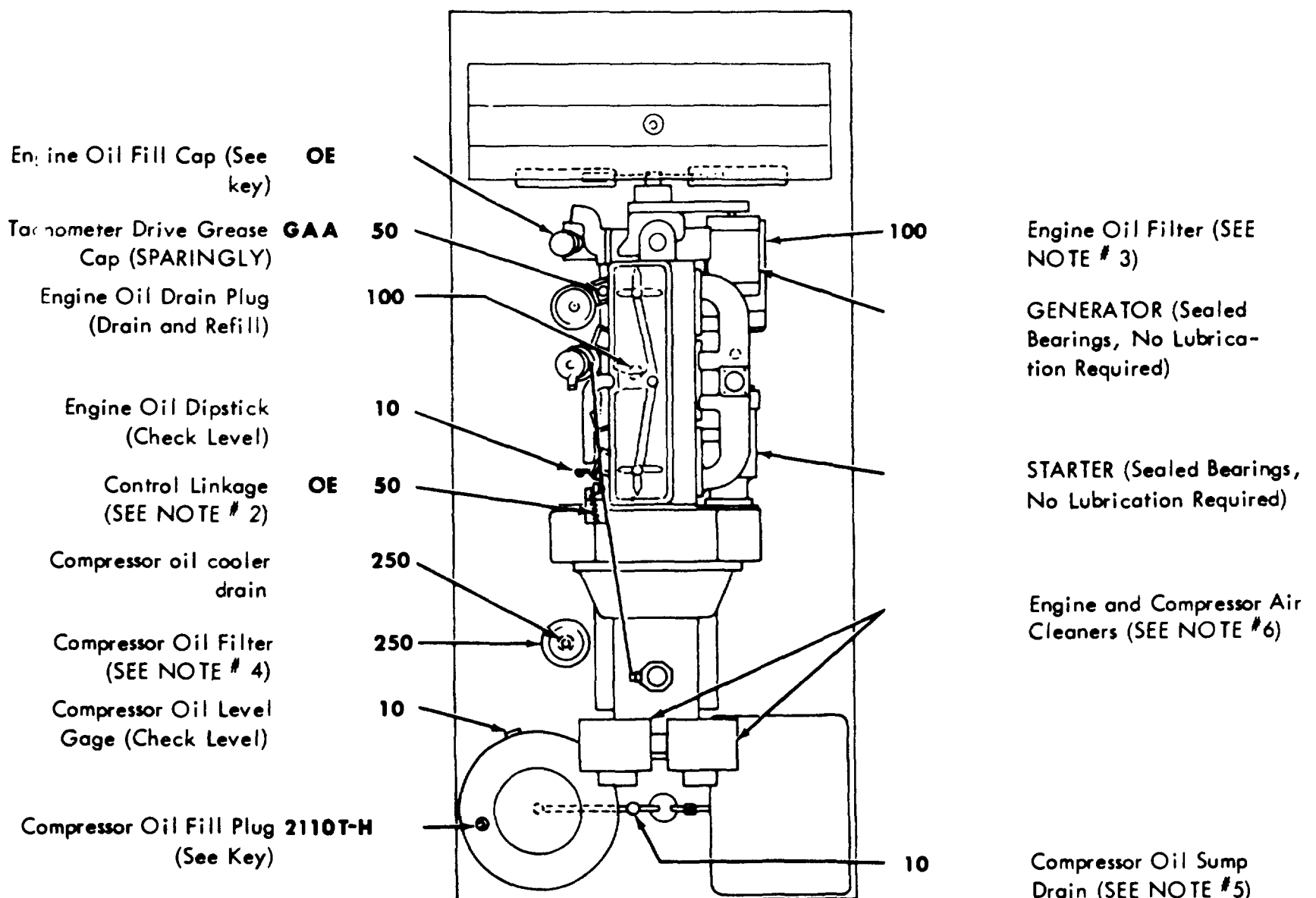

- KEY -

LUBRICANTS	CAPACITY	EXPECTED TEMPERATURES			INTERVALS
		Above +32°F	+40°F to -10°F	0°F to -65°F	
OE OIL, Engine, Heavy Duty		OE 30 or 9250	OE 10 or 9110	OES	Intervals given are in hours of normal operation.
Engine Crankcase	10 1/2 qt				
Oil Can Points					
OES OIL, Engine, Sub-zero		2110T-H	2110T-H	OES	
2110T-H LUBRICATING OIL, General Purpose					
Compressor Oil Sump	34 qt				
GAA GREASE, Automotive and Artillery		All Temperatures.			

NOTES:

1. FOR OPERATION OF EQUIPMENT IN PROTRACTED COLD TEMPERATURES BELOW -10°F. Remove lubricants prescribed in the key for temperatures above -10°F. Clean parts with SOLVENT, dry-cleaning. Relubricate with lubricant specified in the key for temperatures below -10°F.

2. OIL CAN POINTS. Every 50 hours clean and lightly coat control linkages, exposed threads and pins with OE.

3. ENGINE OIL FILTER. Every 100 hours remove filter element, clean housing and install new element, fill crankcase, operate engine for five minutes, check for leaks, check crankcase oil level, and bring to full mark.

4. COMPRESSOR OIL FILTER. Every 250 hours remove filter element, clean housing and install new element. This shall be done only during compressor oil change.

5. COMPRESSOR OIL SUMP. Daily, before operation open the Oil Sump Drain Valve slowly, drain the condensation from the oil sump. When oil appears close the valve. Every 250 hours drain and refill compressor oil sump, operate engine for five minutes, check for leaks, check compressor oil level, and bring to full mark.

6. AIR CLEANERS. The engine and compressor air cleaners are dry type air cleaners.

Copy of this Lubrication Order will remain with the equipment at all times; instructions contained herein are mandatory.

BY ORDER OF THE SECRETARY OF THE ARMY:

OFFICIAL: **HAROLD K. JOHNSON,**
General, United States Army,
Chief of Staff.

Official:
J. C. LAMBERT,
Major General, United States Army,
The Adjutant General.

FOLD

FOLD

LO 5-4310-247-15 DISTRIBUTION: Active Army: USASA (2); ACSI (1); DCSLOG (1); CNOB (1); TSG (1); CofEngrs (3); CC-E (1); Dir of Trans (1); CofSps (1); USAMB (1); USACDCARTYA (2); USACDCARMA (2); USAIB (2); USARADBD (2); USAAESWBD (2); USAAVNTA (2); USCONARC (3); OS Maj Comd (5) except USASETAF (2); USARJ (10); USAMOCOM (2); USASMC (1); MDW (1); Armies (2); Corps (2); Div (2); Engr Bde (1); Svc Colleges (2); Br Svc Sch (2) except USAES (100); USMA (2); Engr Sec. GENDEP (10); Engr Dep (10); Army Dep (2); Trans Tml Comd (2); Army Tml (1); Div Engr (2); Dist Engr (2); USABRDL (3); USA Mob Equip Can (46); Engr Can (5); USAREUR Engr Proc Can (2); USAREUR Engr Sup Can Agcy (10); Chicago Proc Ofc (10); Engr Fld Maint Shops (2); Fld Comd, DASA (8); AMS (3); USAREURCOMZ (2); USAC (1); MAAG (1); JBUSMC (1). Units org under fol TOE: 5-48 (2), 5-237 (3), 5-262 (3), 5-267 (1), 5-278 (3), 5-279 (2). MG: State AG (3). USAR: Units - Same as Active Army except allowance is one copy for unit. For explanation of abbreviations used, see AR 320-50.

This fine document...

Was brought to you by me:



[Liberated Manuals -- free army and government manuals](#)

Why do I do it? I am tired of sleazy CD-ROM sellers, who take publicly available information, slap “watermarks” and other junk on it, and sell it. Those masters of search engine manipulation make sure that their sites that sell free information, come up first in search engines. They did not create it... They did not even scan it... Why should they get your money? Why are not letting you give those free manuals to your friends?

I am setting this document FREE. This document was made by the US Government and is NOT protected by Copyright. Feel free to share, republish, sell and so on.

I am not asking you for donations, fees or handouts. If you can, please provide a link to liberatedmanuals.com, so that free manuals come up first in search engines:

<A HREF=<http://www.liberatedmanuals.com/>>Free Military and Government Manuals

– Sincerely
Igor Chudov
<http://igor.chudov.com/>