

**COMPRESSOR, AIR, TRUCK MOUNTED, GASOLINE DRIVEN,
210 CFM, LE ROI MODEL 210GI**

Reference: TB 5-5065-1

Intervals given are maximums for normal 8-hour day operation. For abnormal conditions or activities, intervals should be shortened to compensate.

Clean parts with SOLVENT, Dry Cleaning, or with OIL, fuel, Diesel, Dry before lubricating.

Relubricate after washing.

Drain crankcase only when hot after operation; replenish and check level when cool.

- KEY -

LUBRICANTS	CAPACITY	EXPECTED TEMPERATURES			INTERVALS
		Above -32 °F	-32° F to -10° F	Below -10° F	
OE-OIL, Engine					D-Daily W-Weekly 2W-2 Weeks M-Monthly Q-Quarterly
Crankcase	22 qts.	OE 30 or 9250	OE 10 or 9110	See Note 1	
Other Points		OE 10 or 9110	OE 10 or 9110	OHA	
OHA-OIL, Hydraulic, Aircraft, Petroleum Base					
BR-LUBRICANT, Ball and Roller Bearing					

LUBRICANT • INTERVAL

INTERVAL • LUBRICANT

- Crankcase Fill **OE**
(See Key)
- Crankcase Breather **OE**
(Clean and re-oil)
- Crankcase Level **OE**
(Check level)
- Radiator Shutter **OE**
Line Air Filter
(Drain and re-fill)
See Note 2

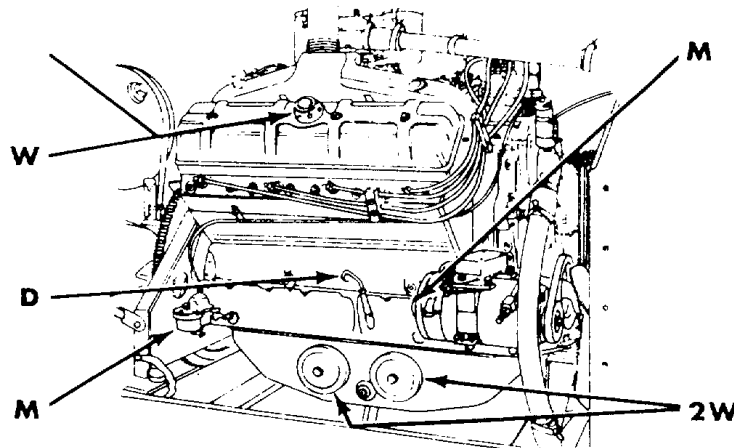

RIGHT SIDE

- BR** Generator Bearings
(Repack commutator end bearings) (When equipped with Life-Seal bearings or oil impregnated bushings, no lubrication is required)
- W** Oil Filters
(Remove, clean, renew elements and replace)

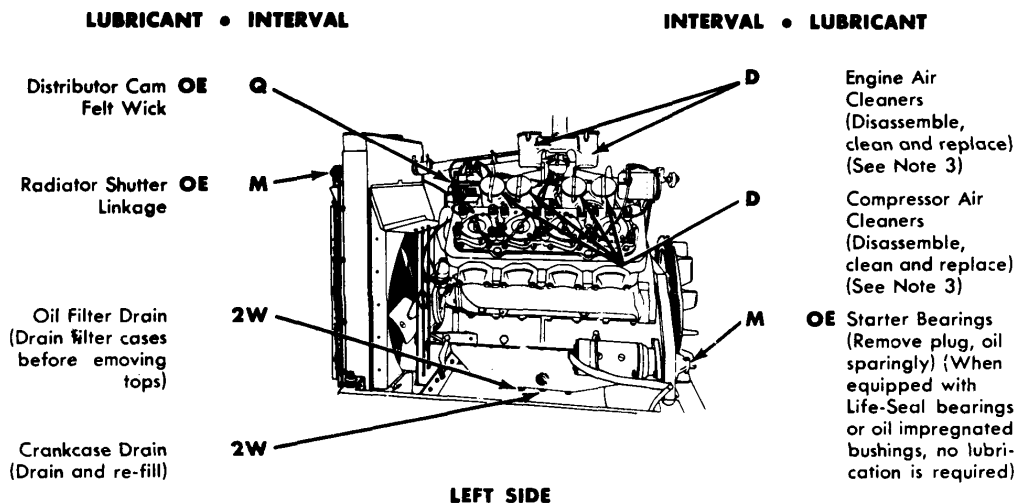

NOTES

1. **COLD WEATHER** (When winterization kit is not available) -Every 3 days, drain crankcase and refill to "Full" mark with OE 10. Add 7 qts of gasoline and run engine 5 minutes to mix. Mark the new level on the oil gage for future reference.

CAUTION: Every 1/2 day check level and fill to "Full" mark with OE 10. If engine is to be shut down for 1/2 day or more, add 7 qts of gasoline to reach new level mark and run engine 5 minutes to mix.

NOTE: OIL, fuel, Diesel may be used as a temporary diluent only when sufficient gasoline is not available.

WARNING: Diluent used is inflammable; do not service equipment near heater or open flame.

2. **SHUTTER AIR FILTER.** Weekly drain shutter air filter and refill with 4 parts of SOLVENT, Dry Cleaning, and one part OE # 10, mix thoroughly, or when not available use Kysor Radiator Shutter Fluid. (Kysor Part #Z1764).

3. **ENGINE and COMPRESSOR AIR CLEANERS.** Blow out elements with compressed air. Do not clean with solvents.

4. **OIL CAN POINTS.** Weekly lubricate governor and carburetor external linkage, housing door hinges and latches, tool box hinges, weather cap hinges, hose reel lock pin with OE. Do not overlubricate.

Copy of this Lubrication Order will remain with the equipment at all times; instructions contained herein are mandatory and supersedes all conflicting lubrication instructions dated prior to the date of this Lubrication Order.

BY ORDER OF THE SECRETARY OF THE ARMY:

M. B. RIDGWAY,
General, United States Army,
Chief of Staff.

OFFICIAL:
WM. E. BERGIN,
Major General, United States Army,
The Adjutant General.

DISTRIBUTION: ACTIVE ARMY: Tech Svc 5 (1) ; Tech Svc Bd 5 (1) ; AFF (3) ; AA Comd (1) ; OS Maj Comd (Z) ; Base Comd (2) ; MDW (2) ; A (5) ; CHQ (2) ; Div (2) ; Brig 5 (1) ; Regt 5 (1) ; Bn 5 (1) ; FT (1) ; Sch 5 (5) ; USMA (2) ; Gen Dep (2) ; Dep 5 (10) ; GH (2) ; Ars (2) ; Div Engr (1) ; Engr Dist (1) ; Mil Dist (1) ; Two (2) copies to each of the following T/O&E's: 5-48A; 5-157; 5-262; 5-267; 5-268; 5-278A; 5-328A; 5-367. NG: One (1) copy to T/O&E units only as listed above.

USAR: None. For explanation of distribution formula see SR 310-90-1.

This fine document...

Was brought to you by me:



[Liberated Manuals -- free army and government manuals](#)

Why do I do it? I am tired of sleazy CD-ROM sellers, who take publicly available information, slap “watermarks” and other junk on it, and sell it. Those masters of search engine manipulation make sure that their sites that sell free information, come up first in search engines. They did not create it... They did not even scan it... Why should they get your money? Why are not letting you give those free manuals to your friends?

I am setting this document FREE. This document was made by the US Government and is NOT protected by Copyright. Feel free to share, republish, sell and so on.

I am not asking you for donations, fees or handouts. If you can, please provide a link to liberatedmanuals.com, so that free manuals come up first in search engines:

<A HREF=<http://www.liberatedmanuals.com/>>Free Military and Government Manuals

– Sincerely
Igor Chudov
<http://igor.chudov.com/>